

UNCLASSIFIED

SUMMARY TECHNICAL REPORT
OF THE
NATIONAL DEFENSE RESEARCH COMMITTEE

CLASSIFICATION CHANGED TO

UNCLASSIFIED

St. Ad. General,
BY AUTHORITY OF

Wash 25, DC. AGAM-P(M)

BY *D. Henry, Jr.*

DATE *20 Aug 63*

~~document contains information affecting the national defense of the United States within the meaning of the Espionage Act, Title 18, U.S.C., Sections 793 and 794, and the transmission or the revelation of its contents in any manner to an unauthorized person is prohibited by law.~~

~~This volume is classified CONFIDENTIAL in accordance with security regulations of the War and Navy Departments because certain chapters contain information which was CONFIDENTIAL at the date of printing. Some chapters may have had a lower classification or none. The reader is advised to consult the War and Navy agencies for information on the reverse of this page for the current classification of any material.~~



UNCLASSIFIED

TECHNICAL LIBRARY
BLDG. 818
ABERDEEN PROVING GROUND, MD.
STEAP-TL

UNCLASSIFIED

Manuscript and illustrations for this volume were prepared for publication by the Summary Reports Group of the Columbia University Division of War Research under contract OEMsr-1131 with the Office of Scientific Research and Development. This volume was printed and bound by the Columbia University Press.

Distribution of the Summary Technical Report of NDRC has been made by the War and Navy Departments. Inquiries concerning the availability and distribution of the Summary Technical Report volumes and microfilmed and other reference material should be addressed to the War Department Library, Room 1A-522, The Pentagon, Washington 25, D. C., or to the Office of Naval Research, Navy Department, Attention: Reports and Documents Section, Washington 25, D. C.

Copy No.

60

This volume, like the seventy others of the Summary Technical Report of NDRC, has been written, edited, and printed under great pressure. Inevitably there are errors which have slipped past Division readers and proofreaders. There may be errors of fact not known at time of printing. The author has not been able to follow through his writing to the final page proof.

Please report errors to:

JOINT RESEARCH AND DEVELOPMENT BOARD
PROGRAMS DIVISION (STR ERRATA)
WASHINGTON 25, D. C.

A master errata sheet will be compiled from these reports and sent to recipients of the volume. Your help will make this book more useful to other readers and will be of great value in preparing any revisions.

UNCLASSIFIED

UNCLASSIFIED

SUMMARY TECHNICAL REPORT OF DIVISION 17, NDRC

VOLUME 2

**COMPASSES, ODOGRAPHS,
COMBAT ACOUSTICS, AND
SONIC DECEPTION**

OFFICE OF SCIENTIFIC RESEARCH AND DEVELOPMENT
VANNEVAR BUSH, DIRECTOR

NATIONAL DEFENSE RESEARCH COMMITTEE
JAMES B. CONANT, CHAIRMAN

DIVISION 17
GEORGE R. HARRISON, CHIEF

WASHINGTON, D. C., 1946

UNCLASSIFIED

NDRC FOREWORD

AS EVENTS of the years preceding 1940 revealed more and more clearly the seriousness of the world situation, many scientists in this country came to realize the need of organizing scientific research for service in a national emergency. Recommendations which they made to the White House were given careful and sympathetic attention, and as a result the National Defense Research Committee [NDRC] was formed by Executive Order of the President in the summer of 1940. The members of NDRC, appointed by the President, were instructed to supplement the work of the Army and the Navy in the development of the instrumentalities of war. A year later, upon the establishment of the Office of Scientific Research and Development [OSRD], NDRC became one of its units.

The Summary Technical Report of NDRC is a conscientious effort on the part of NDRC to summarize and evaluate its work and to present it in a useful and permanent form. It comprises some seventy volumes broken into groups corresponding to the NDRC Divisions, Panels, and Committees.

The Summary Technical Report of each Division, Panel, or Committee is an integral survey of the work of that group. The first volume of each group's report contains a summary of the report, stating the problems presented and the philosophy of attacking them, and summarizing the results of the research, development, and training activities undertaken. Some volumes may be "state of the art" treatises covering subjects to which various research groups have contributed information. Others may contain descriptions of devices developed in the laboratories. A master index of all these divisional, panel, and committee reports which together constitute the Summary Technical Report of NDRC is contained in a separate volume, which also includes the index of a microfilm record of pertinent technical laboratory reports and reference material.

Some of the NDRC-sponsored researches which had been declassified by the end of 1945 were of sufficient popular interest that it was found desirable to report them in the form of monographs, such as the series on radar by Division 14 and the monograph on sampling inspection by the Applied Mathematics Panel. Since the material treated in them is not duplicated in the Summary Technical Report of NDRC, the monographs are an important part

of the story of these aspects of NDRC research.

In contrast to the information on radar, which is of widespread interest and much of which is released to the public, the research on subsurface warfare is largely classified and is of general interest to a more restricted group. As a consequence, the report of Division 6 is found almost entirely in its Summary Technical Report, which runs to over twenty volumes. The extent of the work of a division cannot therefore be judged solely by the number of volumes devoted to it in the Summary Technical Report of NDRC: account must be taken of the monographs and available reports published elsewhere.

The research work of Division 17 included a wide variety of projects, ranging from the detection of land mines to the characteristics of the human ear, from helium purity indicators to the telemetering of strain gauges, from odographs to sound-ranging devices. It is a tribute to the broad knowledge of the Division Chiefs—Paul Klopsteg and, later, George R. Harrison—and to the versatility of the men who worked under them that so diverse a program was handled so competently.

A considerable portion of the work of Division 17 had to do with the shattering noise of modern war, and answers were sought and supplied to such questions as: How much noise can a human being stand? What clues must the human ear have in order to understand a spoken message? How much distortion can be tolerated? These and other phases of the Division's work are dealt with in the Summary Technical Report prepared under the direction of the Division Chief and authorized by him for publication.

The diversity of the Division's projects made it inevitable that its staff should be composed of men with many types of scientific training and that the Division should draw on contractors with a wide range of experience and skills. The studies of noise, in particular, meant that the technical staff must include physicists, acousticians, and psychologists. For the ability and devotion of these men of many aptitudes we express our gratitude.

VANNEVAR BUSH, Director
Office of Scientific Research and Development

J. B. CONANT, Chairman
National Defense Research Committee

FOREWORD

THE APPLIED PHYSICS DIVISION of the Office of Scientific Research and Development [OSRD] was organized late in 1942 under the chairmanship of Dr. Paul E. Klopsteg, who was responsible for the work of the Division until shortly before the completion of its work when other duties required his full attention. Most of the projects which had been initiated by the Instruments Section of the National Defense Research Committee [NDRC] during 1940 and 1941 and which were not concerned with optics were turned over to the Applied Physics Division on its inauguration. Dr. Klopsteg as Chief and Dr. E. A. Eckhardt as Deputy Chief went with them from the Instruments Section to the new Division.

The Summary Technical Report which is presented in these volumes thus covers the accomplishments of projects set up by both Section D-3 and Division 17. The work of the Division covered a very wide range of fields. The term *Applied Physics* served in lieu of a more descriptive name for a Division which was in fact the one to which was assigned any scientific

problem which did not properly come under one of the other divisions of NDRC.

Actually the Division was an association of three Sections having rather dissimilar responsibilities and fields of activity. In setting up these Sections it was necessary to group the projects already under way into a small number of coherent categories, and those chosen were Sound, Electricity, and General Instrumentation. The work of the Division consisted entirely of the integrated efforts of these three Sections, whose membership will be found listed on a succeeding page.

For more detailed reports on the technical work of the Division than are contained here-with the detailed contractors' reports of Division 17 should be consulted, and appropriate reference to these have been made throughout the present volumes. The results obtained are also presented in less technical form in that volume of the history of OSRD entitled *Optics and Applied Physics in World War II*.

GEORGE R. HARRISON
Chief, Division 17

PREFACE

THE RESEARCH and development program of Division 17, NDRC, was concerned with those problems in physics not specifically covered in other Divisions of NDRC. As the result, the Division fell heir to a myriad of miscellaneous problems of a physical nature which, in themselves, were not often interrelated. It would have been exceedingly difficult, if not impossible, for Division 17 to set up within itself a sufficient number of Sections to deal specifically with all the various classes of problems which fell under their jurisdiction. Therefore, the projects of the Division were assigned to one of three Sections—Section 17.1, Instruments; Section 17.2, Electrical Equipment; and Section 17.3, Acoustics—whose broad titles permitted a general, even if somewhat loose, classification. It was not always easy to decide, at times, under which of these three broad categories a given project should be placed. In these cases, considerations such as immediate convenience and availability of experienced personnel were often the determining factors.

The Summary Technical Report describing the activities of Division 17 is presented in four volumes. In an attempt to achieve a little greater uniformity of subject matter, the projects were organized within the various volumes without regard to their Section classification. Consequently, there is, on the whole, little relationship between volume and Section number. Because of the varied problems dealt with in the Division's program, very little continuity is to be found from chapter to chapter in any volume. Each chapter attempts to summarize independently the results of a particular project.

Since there were a large number of diversified projects in Division 17, it was obviously impossible to do justice to each, even in summary. It is not intended that the importance of any project described herein should be judged by the amount of page space allotted to it. Naturally, certain problems involved more research and development than others before they could be brought to a successful conclusion. In many cases, this is reflected in the Summary Technical Report. On the other hand, the presentation of the projects may mirror the enthusiasm (or lack of it) of the individual author at the time of writing. Therefore, the reader who desires more than a broad panorama of the Division's activities is referred to the Microfilm Index for more complete details.

This second volume of the Division 17 Summary Technical Report is divided into two parts. Part I contains six chapters dealing with various general types of instruments for combat use. The instrumentation described in these chapters differs from that in Volume 4 in that this latter volume described instruments of a laboratory or training nature.

The seven chapters comprising Part II of this volume deal with combat acoustics, sonic deception and simulation. Although the subject matter of the individual chapters varies somewhat, the underlying problems, theory, and techniques encountered throughout are similar. In this way, then, there is a distinct correlation between the projects presented in Part II.

The reader may wonder why the material in Part II, which deals essentially with sound, was not placed in Volume 3, which is solely devoted to problems of sound. In the first place, Volume 3 of this Report represents the work of one particular laboratory whereas the projects outlined in Part II of Volume 2 are the contributions from several laboratories. The second reason for not including the chapters of Part II in Volume 3 is that the Volume 3 subject matter is closely coordinated and there seemed no logical reason for destroying the continuity of a volume that was complete in itself.

Every reasonable effort has been made to keep this volume free from error, scientific or otherwise. Should some creep in, the authors and editor would be grateful to have them called to their attention. Although this is a technical report, by its very nature it is inevitable that opinions other than scientific may be expressed. The reader is reminded that these do not necessarily reflect the opinions of the authors, editor, nor NDRC as a whole, but rather those of Division 17.

It should be borne in mind that the material contained in these chapters represents a summary of the combined efforts of many men who labored so faithfully for so long for so little personal recognition. Although certain of these men, as authors, bore the brunt of preparing this volume, many others contributed freely of their time to read authors' manuscripts, for accuracy, Division and NDRC policy, and offered valuable suggestions and criticisms, answered innumerable questions. To these men, then, as well as to the authors, the editor of this volume expresses his deep appreciation.

Lest the mention by name of all those who contributed to the preparation of this volume be considered as a listing in minor hall of fame, it has been purposely avoided. The name of the author will be found under the chapter titles. Where no name appears, the editor, with the

help of innumerable Division members, Contractor employees, and friends, has prepared the summary from the various contractors' reports.

CHAS. E. WARING
Editor

CONTENTS

PART I

GENERAL INSTRUMENTATION

CHAPTER		PAGE
1	Compasses and Odographs by <i>L. L. Nettleton</i>	3
2	T-58 Photoflash Fuze by <i>George E. Beggs, Jr.</i>	58
3	Oximeters	68
4	Radio Chronometer Comparator	73
5	Fuel Quantity Gauges	75
6	Combustion Efficiency Indicator for Naval Vessels by <i>F. L. Yost</i>	80

PART II

SOUND TRANSMISSION AND INSTRUMENTATION

7	Ultrasonic Signaling by <i>Harold K. Schilling</i>	87
8	Jungle Acoustics by <i>Carl F. Eyring</i>	92
9	Attenuation of Sound in the Atmosphere by <i>V. O. Knudsen</i>	106
10	Injurious Effects of Exposure to Loud Tones and Noises	110
11	High-Intensity Sound Produced by Chain Explosions	113
12	Sound Simulation and Masking	117
13	Mobile Loudspeaking Systems for Deception and Decoy	131
	Glossary	171
	Bibliography	173
	OSRD Appointees	178
	Contract Numbers	180
	Service Project Numbers	183
	Index	185

PART I
GENERAL INSTRUMENTATION

Chapter 1

COMPASSES AND ODOGRAPHS

By *L. L. Nettleton*

1.1 SUMMARY OF COMPASS AND ODOGRAPH DEVELOPMENT

1.1.1 Historical Summary

THE DEVELOPMENT covered by this report was originated by a suggestion early in 1941 from the Army Engineer Board to the National Defense Research Committee [NDRC] that investigations be made for two purposes, i.e., (1) to determine the feasibility of using magnetic compasses in heavily armored vehicles, particularly tanks, and (2) if such compasses were feasible, the development of an automatic course-plotting or dead-reckoning tracing device.

The required investigations and tests were carried out over a period of nearly five years under contracts originally let in 1941 and 1942 between NDRC and four different scientific and engineering organizations and with the cooperation of both the Army and the Navy. Most of the fundamental development, the establishment of working principles, and first field tests were carried out under Section C-3. The work was continued and some contracts were extended when the project was transferred to Section 17.1 of NDRC in December 1942. The production of equipment in quantity was handled by direct Army contracts. Many improvements and extensions and the experimental applications to military equipment were handled largely by cooperation between NDRC, its contractors, and the Services.

The development was quite continuous, and no distinction is made in this report between those parts which were under the auspices of Section C-3 and those under Section 17.1.

1.1.2 General Evaluation of the Project

The work on compasses under these contracts has resulted in much useful information regarding methods of compensation and has enabled the Services to extend the use and improve the

performance of magnetic compasses in many applications heretofore believed impossible. Magnetic compasses have been made to perform satisfactorily both inside and outside of tanks, command cars, armored cars, and jeeps. The Navy Department has made use of the information to redesign and standardize compasses for all classes of craft.

The odograph has been applied successfully on a substantial scale to reconnaissance missions, to mapping, to fire control, and ranging problems, and has proved particularly useful in jeep installations. It has been used successfully in landing craft and similar small marine installations, in DUKW's, and in various other types of specialized vehicles, such as the Weasel. The airborne unit contributed materially to the reconnaissance missions preceding the invasions of the Philippines and to other Southwest Pacific missions. While the Air Forces' use of the equipment was limited, the contribution was nonetheless important. The odograph proved particularly successful in the rough mapping of strange terrain by infantry personnel.

As mentioned, the demand for a vehicular odograph originated in the Engineer Board, Corps of Engineers, U. S. Army. Its development was strongly supported by both the Army and the Navy. The adaptation of the device to aircraft was visualized by NDRC and its contractors and was carried forward by them on the basis of definite interest by several Army units and in anticipation of more general Service support. This never materialized. It is believed that lack of merit of the device and absence of need for its functions were not basically the cause for the failure of active Service interest to develop.

1.1.3 Summary of Developments under the Project

Early in 1941, NDRC entered into a contract (NDCrc-187) with the Department of Terres-

trial Magnetism [DTM], Carnegie Institution of Washington for compass and odograph investigations. The possibility of satisfactory compensation of a compass, even when inside of a tank, was demonstrated, and the development of an automatic mapping device was then undertaken. The first such device was made by DTM, the integrating element in the odograph being a gear with variable stepped teeth. This original instrument included many parts from a Monroe calculating machine and was first demonstrated in a station wagon in January 1942.

Shortly after this demonstration, Contracts OEMsr-340 and OEMsr-426 were entered into between NDRC and the Monroe Calculating Machine Company [Monroe] and International Business Machines Corporation [IBM], respectively, for manufacture of pilot models of odograph instruments. Monroe undertook to engineer for manufacture the original DTM integrator and, later, the DTM compass, which became known as the standard compass. IBM developed an independent integrator based on a variable ratchet drive. The pilot models of these integrators were tested in various land vehicles and their military usefulness determined to the extent that the Army negotiated contracts with both Monroe and IBM for manufacture of compasses and integrators in considerable numbers.

At the request of the Army, Contract OEMsr-1121 was entered into between NDRC and General Motors Research Laboratory [GM] for the development of an inductor-type compass. The original purpose was to investigate an independent compass type and possible alternative source of supply. Later it was found that the performance of the GM compass was much superior to that of the standard compass under conditions of severe shock and vibration. In the meantime, the standard compass was greatly improved until its performance was nearly as good as that of the inductor compass, except under the most severe conditions. The GM inductor compass was never manufactured in quantity, either for use as a compass alone or in connection with odograph installations, because (1) the improved DTM compass uses simpler electric accessories which had already

been adapted to numerous odograph installations, (2) the Service problems of restandardization would be severe, and (3) the remaining performance difference was rather small.

Along with the compass developments, General Motors developed a *magnetic eraser* to control semipermanent magnetization of vehicles and thereby reduce this, by far the most troublesome source of compass errors. Extensive tests made by the contractor on a tank and a jeep showed substantial overall reduction in compass errors to be available from the use of the magnetic eraser. It was apparently believed by the Services that the devices required would be too complicated and that their power requirements would be too high to justify their application. The NDRC representatives did not concur in this view, and it is felt that, in any future use of magnetic compasses in tanks, the related work of General Motors could be reviewed and extended with profit.

The success of the vehicular device led to the development of the airborne odograph which had been contemplated early in the program. IBM, originally at their own expense and later in cooperation with NDRC, developed an integrator using a friction disk drive with variably positioned pickup rollers moving over the face of a disk driven at a rate proportional to the speed of the plane. This integrator was originally adapted to the Schwien true airspeed meter and later to the British and Pioneer air mileage units for giving the rotation of the disk proportional to the air distance traveled and to the Pioneer gyro-stabilized fluxgate compass for giving the direction. (These accessory devices had been developed previously for other purposes.) The integrator also incorporates a second disk drive assembly (a second integrator) by which correction for wind drift can be set so as to give position with respect to the ground. A relatively large map is made on a remote, electrically driven plotting table, and one or more such tables plotting at different scales, if desired, may be used at locations independent of the other parts of the installation.

This airborne odograph was tested in several types of aircraft and gave quite satisfactory performance. These devices were manufactured and used in rather limited number.

Odograph installations were made also in various boats and amphibious vehicles. This required the development of a water-driven speedometer and associated servomechanism to operate the odograph without drawing appreciable power from the impeller unit in the water. Application to amphibious vehicles (DUKW) also required a means of shifting the odograph drive from the water element to an ordinary speedometer cable when changing from water to land operation.

Other developments toward the end of the program were the *pedograph* and the *step-writer*. The *pedograph* is a relatively simple instrument carried by a man; the distance component is given by a thread which rotates a pulley as it is pulled out of the instrument and the direction by a manually operated compass follower. The *step-writer* is a somewhat simpler device in which the distance is given by impulses from a connection to the operator's leg and the direction by manually turning the mapping paper to keep it aligned with the compass.

The compass development made possible compasses which were manufactured by tens of thousands for use in many kinds of Army and Navy vehicles. Also, some 2,000 land odographs and some 50 aerial odographs were made. These developments have obvious peacetime applications and have led to actual or contemplated use in improved automobile and ship compasses and use of vehicular odographs in exploration and mapping.

1.2 REQUIRED ELEMENTS AND FUNCTIONS PERFORMED

1.2.1 Requirement of Compass, Distance, Integrating, and Power Supply Units

In order to plot the course of a vehicle, it is necessary that we know at all times its direction and distance from some reference or starting point. This requirement will be fulfilled if, at all times, the north or south component and the east or west component of the distance traveled are known. Thus it is essential that the

instrument for course plotting contain the following elements:

1. A compass of some kind which gives a reference direction with respect to which the cardinal component of each element of travel may be resolved.

2. A log or odometer element (or a speed-measuring element) from which increments of distance traveled may be determined (either directly in terms of distance, or indirectly in terms of speed multiplied by time).

3. An *integrator* which combines the indications from the compass and the distance- or speed-measuring unit in such a way that each increment in distance is resolved into its components, one parallel to and one perpendicular to the reference direction. These components of motion operate two counters by which the instantaneous coordinates of position are shown and two perpendicular screws which move a pencil to make a continuous trace of the path traveled by the vehicle.

4. A power supply unit which converts the available primary electric source (usually vehicle batteries) into the voltages and frequencies required for the various electrical operations.

In any particular application, a complete odograph installation will be made up in various ways, depending upon the type of the vehicle and use for which it is intended. The choice of compass, distance (or speed), and integrator combination will be dictated by the circumstances surrounding the application. Each of the four elements (compass, log, integrator, and power supply) is usually a more or less independent unit, and the different elements are electrically or mechanically connected in various ways, which are dictated by magnetic, mechanical, and electrical conditions of the vehicle. The plotting table may be either a part of the integrator unit to which it is connected through appropriate gearing, or it may be operated electrically at a point remote from the integrator unit itself.

A TYPICAL ODOGRAPH INSTALLATION

Figure 1 shows an installation in a $\frac{1}{4}$ -ton 4x4 truck (jeep) which was probably the Army vehicle most frequently carrying odograph

equipment because of the relative simplicity of its installation and because of its utility in reconnaissance. The units of the installation,

is obtained. Figure 3 shows a map made with an installation of the type shown by Figures 1 and 2.

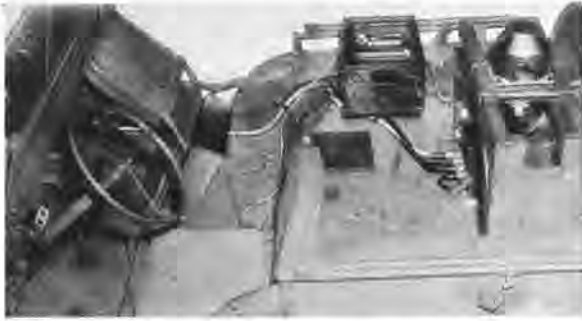

FIGURE 1. Land odograph, Model M-1, installed in a 1/4-ton 4x4 truck (jeep).

comprising compass, odograph with plotting table, and power pack, are evident in the picture. The units themselves and the connections

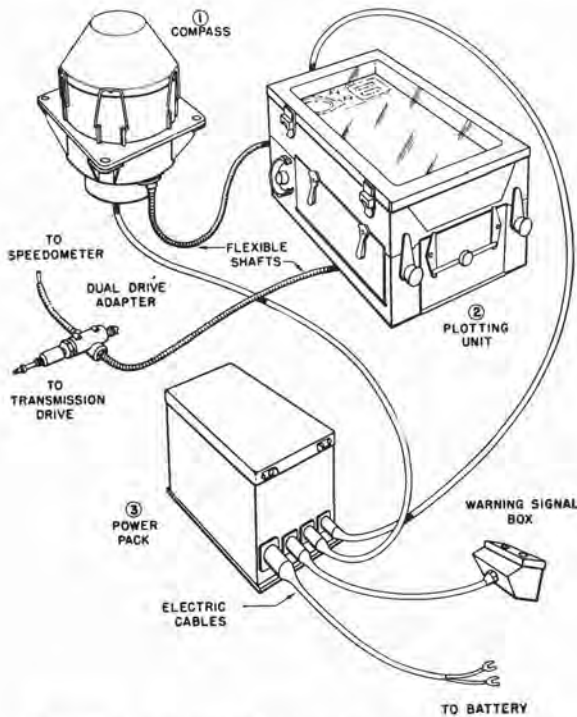

FIGURE 2. Schematic arrangement of odograph components and connections for installation on a jeep.

between them are shown diagrammatically by Figure 2, which also indicates the speedometer cable connection from which the distance input

1.3 COMPASSES AND COMPASS COMPENSATION

1.3.1 General Requirements

COMPASS PRINCIPLES AVAILABLE

There are two general types of compass which might be applied to an odograph. These are, first, the gyroscopic compass and, second, the magnetic. The magnetic compass may be

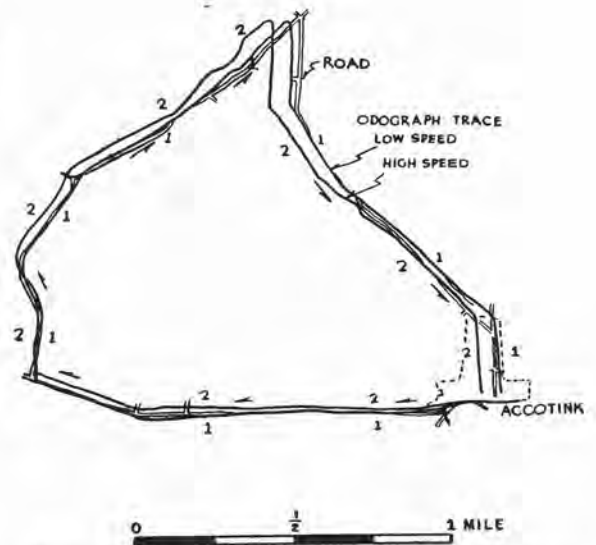

FIGURE 3. Map from odograph installations in a jeep, showing mapped trace and actual roads traveled.

either the ordinary magnetic needle or an inductor type which uses the principle of a transformer with a core of high-permeability material so that the induced or secondary voltage is controlled by the effect of external magnetic fields on the core. Each principle has certain advantages and disadvantages which must be considered in connection with odograph applications.

GYROSCOPIC COMPASSES

The gyroscopic compass has the advantage that it is not affected by its environment, that

is to say, its operation does not depend upon masses of magnetic material in its neighborhood. It has two disadvantages, i.e., first, its mechanical complication involving an air or electric supply to drive it at a very high speed, and second (and a much more formidable one), an ordinary gyroscope will maintain a given azimuth or direction of orientation only within limits, as there is always a tendency for precession, which produces a drift of the gyroscope away from its originally established orientation. This drift is such that it is not possible to use a simple gyroscope as a primary direction reference, for it requires that the gyroscope be reset occasionally (resetting at about 15-minute intervals is used on airplane applications) with respect to some other direction reference. The use of a self-directing or north-seeking gyroscopic compass, such as is used on ships, would hardly be feasible on small or land vehicles. A gyroscopic ship's compass is a comparatively large and elaborate installation and has a very slow period, so that it requires operation over long periods of time to give reliable direction indications. It is very doubtful that such a compass could be made to operate under the very severe conditions of shock and rapid changes in direction that must be met in many odograph applications. It could be used on large ships or other vehicles where the compass itself would operate satisfactorily for, in principle, any compass indication could be applied to an odograph.

MAGNETIC COMPASSES AND MAGNETIC DISTURBANCES

The essential indicating element of a magnetic compass is very simple, but any magnetic compass (either a simple magnetic needle or an inductor type) is subject to disturbances from magnetizable parts of any vehicle in which it may be installed and from the magnetic fields of any electric auxiliaries with which the vehicle may be equipped. Means (described in the following section) have been developed by which compensation for these effects can be attained to a degree which permits satisfactory compass operation on most vehicles. Most of the inaccuracies of operation and limits to the precision of compasses and of odograph maps result from the fact that the magnetic state of the ve-

hicle is variable. This change with time of the magnetic condition of the vehicle and especially in vehicles with large magnetic mass, such as tanks, requires that the compensation be checked frequently. These difficulties must be attacked by reducing or stabilizing the magnetic disturbances of the vehicle, and particularly that part of it containing the compass. No gain can result from improving the compass itself until the magnetic environment is controlled.

COMPASS FOLLOWERS

Some sort of servomechanism must be controlled by the compass and be "slaved" so as to follow its indication, but must operate in such a way (through light or electric impulses) that it does not affect the primary direction indication resulting from the action of the earth's magnetic field on the compass. In all the odograph installations, the servomechanism is operated in such a way that the compass follower tends to overshoot a position of balance so that it "hunts" about a position controlled by the directing magnetic field. As will be pointed out later, this hunting is a necessary characteristic for two reasons: (1) it serves to interpolate between discrete steps of increment in the integrator mechanism, and (2) it serves to eliminate any effects of backlash or looseness in the gears and mechanical connections between the compass follower and the elements in the integrator which it controls.

1.3.2

Compass Compensation

INTRODUCTION

The use of the magnetic compass in connection with an odograph installation implies that the compass will maintain its north-south indication, controlled by the horizontal component of the earth's magnetic field, without regard to the direction of heading or attitude of the vehicle on which it is mounted. As the vehicle itself practically always contains some iron parts which are magnetized permanently, semi-permanently, and/or by induction, the compass indication will, in general, be affected by disturbances arising from such magnetization, and the elimination of such disturbances by com-

pensation is one of the major problems in maintaining a reasonably precise magnetic reference direction.

The general theory of compass compensation has been worked out in considerable detail in connection with the use of magnetic compasses on shipboard. Certain parts of this theory are directly applicable to the compensation of the compasses on ground vehicles, but, in general, the conditions to be met are more severe, the problem is more complicated, and the degree of compensation obtainable is less exact than on shipboard.^{15a}

SEMICIRCULAR ERROR

There are two types of disturbance which must be compensated. The first arises from permanent magnetic fields which are set up by magnetic material of the vehicle which is permanently magnetized and therefore retains its direction and magnitude of magnetization with respect to the vehicle as the vehicle changes its heading and thereby its relation to the earth's magnetic field. This type of disturbance causes the semicircular error, so called because its effects vary with the sine and cosine of the angle of heading (since these magnetic effects, being carried with the vehicle, change their relation to the orientation of the compass as the heading is changed). The semicircular error may be compensated by properly positioned and adjusted permanent magnets placed in the vicinity of the compass and so situated that the fields which they produce at the compass magnet are equal and opposite to the permanent fields produced by the permanently magnetized parts of the vehicle. Two sets of adjustable permanent magnets (see Figures 4 and 5), giving fields in perpendicular (N-S and E-W) directions, are required to compensate for the horizontal components of permanent magnetization. As is pointed out later, a third set, to give a vertical component, is needed to compensate for the magnetic component which becomes active when the vehicle is not level.

QUADRANTAL ERROR

The second type of magnetic disturbance comes from "soft" magnetic materials in which magnetization is induced by the earth's mag-

netic field. The disturbance at the compass produced by such fields varies with the relation of the earth's field to the vehicle and therefore varies as the heading of the vehicle is changed. Such induced fields lead to the quadrantal error, so called because their effects vary with the sine and cosine of twice the angle of heading. Compensation for this type of error is obtained by the use of soft iron masses in the vicinity of the compass, so placed that the fields at the

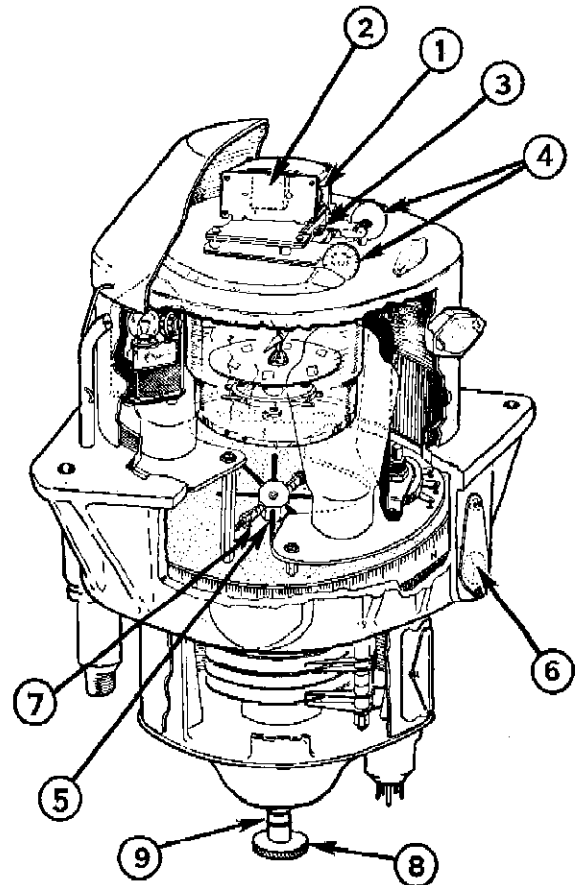

FIGURE 4. Cutaway diagram of compass showing compensating system.

compass resulting from the magnetization of these masses by the earth's field (and by the compass needle itself in some applications) are equal and opposite to the field produced by induction in other parts of the vehicle. The standard procedure for quadrantal compensation as developed for ship's compasses has been to place rather large, soft iron spheres (or cylinders) near the compass, the magnetization of these spheres resulting from induction by

the earth's field. However, the spheres required are quite bulky, as they must be placed at sufficient distances from the compass so that they will not be materially affected by the magnetic field of the compass needle itself.

A procedure developed in connection with the compass project was the use of much smaller masses of magnetically soft material placed

and midcardinal azimuths with respect to the coordinate system of the vehicle. (See Figure 4.) Each arm carries Permalloy collars (or washers) held in place by nuts on the arms of the spider. By adjusting the number and position of the Permalloy washers on the several arms of the spider and following out a fixed procedure of making the adjustments with the vehicle in certain definite headings, quite effective compensation for quadrantal errors is obtained.²¹

HEELING AND PITCHING ERRORS

The consideration of semicircular and quadrantal compensation as outlined above is based on the assumption that the compass itself and the vehicle are substantially level. Other errors are induced by heeling (i.e., lateral tilt of a vehicle, as, for instance, when driving on the side of a crowned road) and pitching (whether going uphill or downhill). It turns out that, while the heeling errors may be quite large, effective compensation may be achieved by the use of permanent magnets producing a vertical field at the compass. It also turns out that the pitching error is partially compensated by the heeling correction and that, if the compass is placed where the quadrantal deviation is small, the residual pitching error is usually negligible.

SUPERPERMANENT MAGNETIZATION

By the use of three sets of magnets, such as are indicated in Figures 4 and 5, giving properly adjusted permanent field components at the compass in the three principal directions, the semicircular and heeling errors may be quite effectively compensated, and, by the use of properly placed small masses of easily magnetizable material near the compass, the quadrantal error is quite completely compensated. Thus the compass may be made to give the same readings within one degree or less in all headings as long as the magnetic condition of the vehicle remains the same as that for which the compensation adjustments were made.

²¹ This principle cannot be applied to inductor (transformer) type compasses because there is no magnetized needle to affect the Permalloy compensators, so larger, soft iron cylinders or spheres must be used (see Figure 34, Section 1.6.2). However, these iron masses can be smaller than for ordinary ship's compass compensation because there is no magnetic needle to magnetize them as it changes its position.

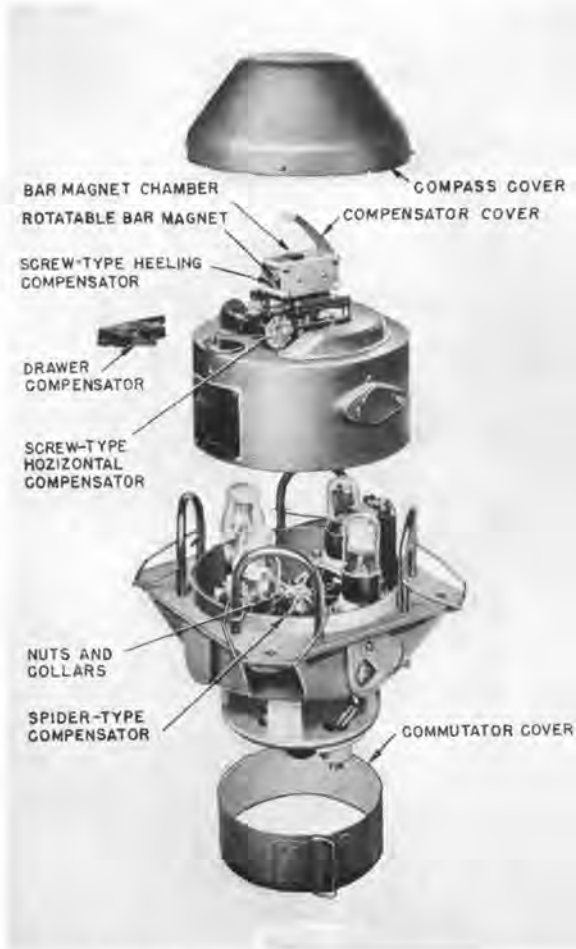

FIGURE 5. Pictures of compass parts.

relatively close to the compass so that the magnetization induced in these masses is largely that produced by the magnetic field of the compass needle itself. Analysis has shown and practice has confirmed that quite satisfactory compensation of the quadrantal error can be obtained in this way. In practice, the compensation is achieved by a small, horizontal, eight-armed spider with the arms oriented in cardinal

The most serious source of compass error is in the subpermanent magnetization. This is defined as magnetization of the induced type in parts of the vehicle which are not completely soft magnetically, so that some of the magnetization induced when in one heading is retained when the heading is changed. Such magnetization may be greatly modified by mechanical shock. It turns out that the subpermanent magnetization affects the semicircular compensation much more than the quadrantal. Since the changes in subpermanent magnetization depend upon the mechanical shocks to which the vehicle is subjected, the heading of the vehicle at the time of such shocks, and subsequent changes in heading, none of which can be anticipated, errors due to these disturbances cannot be compensated. However, there are means by which they can be substantially reduced.

Certain of the effects of subpermanent magnetization can be reduced by proper selection of the position of the compass with respect to the vehicle, particularly in placing the compass in a position which is symmetrical with respect to the magnetizable masses. Extensive tests of a compass mounted in various positions on a jeep and with certain modifications of the structure of the vehicle itself were carried out^{15b} to analyze in some detail the causes and sources of these subpermanent magnetic disturbances. The only way to completely eliminate such disturbances would be to have the compass several feet away from any magnetizable part of the vehicle, which, of course, is quite impractical. It is feasible, however, to find places where the disturbances due to subpermanent magnetization are small enough so that a practical compass installation may be made, and such installations have been accomplished in a large variety of military vehicles. The subpermanent magnetization remains, however, the largest single source of error in vehicular compasses and in the production of odograph maps, and the differences in the effectiveness of odograph installations on various vehicles and the great difficulty in achieving really good odograph performance in tanks arise from these subpermanent effects. No degree of perfection of the compass itself or of compensation will take care of these effects permanently, and in heavy ve-

hicles, such as tanks, they require readjustments of the compensation at intervals of, at most, a few days or a few hundred miles of driving to maintain tolerable performance.

MAGNETIC FIELDS OF TANKS AND OTHER VEHICLES

In connection with the development of magnetic mines against tanks and of possible means of countering such mines, extensive measurements were made of the magnetic fields of tanks and other vehicles. This work, carried out by DTM, was not part of the Odograph and Compass project and was under an entirely separate contract (OEMsr-151). However, some of the instruments and the measurements carried out in this connection¹⁴ are pertinent to magnetic compass development in that they are concerned with the same physical (i.e., magnetic) properties of the vehicle which are encountered in the problems of compass compensation.

The instrument developed is a permeability-type, remote-indicating magnetometer. A six-channel unit was made which would indicate and record simultaneously the variations of the magnetic field in any chosen direction as picked up by each of the six sensitive elements.

Extensive measurements were made of the magnetic fields, particularly under tanks, and detailed mathematical analyses carried out, primarily from the standpoint of the design of magnetic firing devices for mines. The purpose of mentioning this work here is simply to call attention to the methods of measurement of magnetic fields and the many profiles and maps of field patterns which are contained in the report,¹⁴ as a review of this work should be very useful if it again becomes important to consider means of improving compass performance in heavily armored vehicles.

1.3.3 Demagnetization of Military Vehicles

It has been mentioned that the subpermanent magnetic effects constitute a serious difficulty in operating a magnetic compass in a vehicle containing massive iron parts. An attack on this problem was made by the construction of

a *magnetic eraser* which was designed to demagnetize the vehicle in such a way that the subpermanent magnetic effects would be reduced and/or stabilized.

THE MAGNETIC ERASER

The general principle of the magnetic eraser is that of maintaining a repeated cycle of alternating magnetic fields in different directions in certain selected parts of the vehicle rather than in trying to completely demagnetize the disturbing iron parts. Experiments¹⁹ show that, when an attempt is made to demagnetize iron pieces by gradually reducing the strength of an alternating field, a point is reached at which the residual magnetization is no longer reversed by the reversals of the field and the magnetization therefore can be reduced only to a certain minimum. The situation is somewhat analogous to rocking a coin back and forth in the bottom of a rounded bowl. If the bowl is tilted strongly from one side to the other, the coin will slide from side to side corresponding to the reversals of magnetization which result from reversals of a strong magnetic field. If the angle through which the bowl is tilted is gradually reduced, a point will be reached at which friction is not overcome, and the coin will cease to slide back and forth with each oscillation and will no longer move relative to the bowl. This degree of tilting corresponds to the magnetic field strength at which reversals of magnetization cease to occur, and the magnetization corresponding to this point is the minimum which can be reached by reversals of a decreasing magnetic field. In tests with steel bars and blocks and large welded steel boxes, it was found that the field strength at which the reversals of magnetization cease is about 50 oersteds and that the remaining magnetization is erratic and of the order of 10 to 20 gauss.

The magnetic eraser operates on a continued cycle of reversals of magnetic fields of sufficient strength so that the magnetization of the iron follows the reversals. This corresponds to controlling the mean position of the coin in the tilting bowl so that it tends to oscillate about the center rather than trying to make it come to rest at the center.

It was found that considerable reduction in

the disturbances due to semipermanent magnetization could be expected if the vehicle were carried through a systematic series of magnetizations by coils placed so that a magnetizing field could be induced in each of the three principal coordinates and current switched through these coils in such a way as to apply the magnetic field in a repeated cycle of magnetization in directions N, E, Up, S, W, Down, and repeated. The power supply, switching, and coils to supply this repeated cycle of magnetization constitute the magnetic eraser.

APPLICATIONS AND TESTS OF THE MAGNETIC ERASER

In order to apply the magnetic eraser to military vehicles, coils are put either about towel

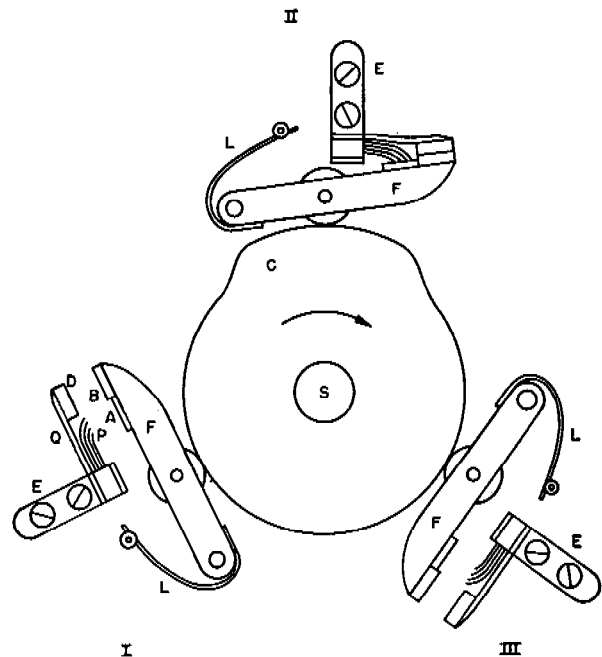

FIGURE 6. Diagram of magnetic eraser switch.

bars (which are iron bars welded to the structure especially for the application of the magnetic eraser) or around existing parts of the structure. The installation of the magnetic eraser consists of suitable coils and bars so that magnetization can be induced in the vehicle in horizontal, transverse, and vertical directions, a suitable motor-driven switch for switching the current among the coils to give the desired cycle of magnetization, and a suitable power

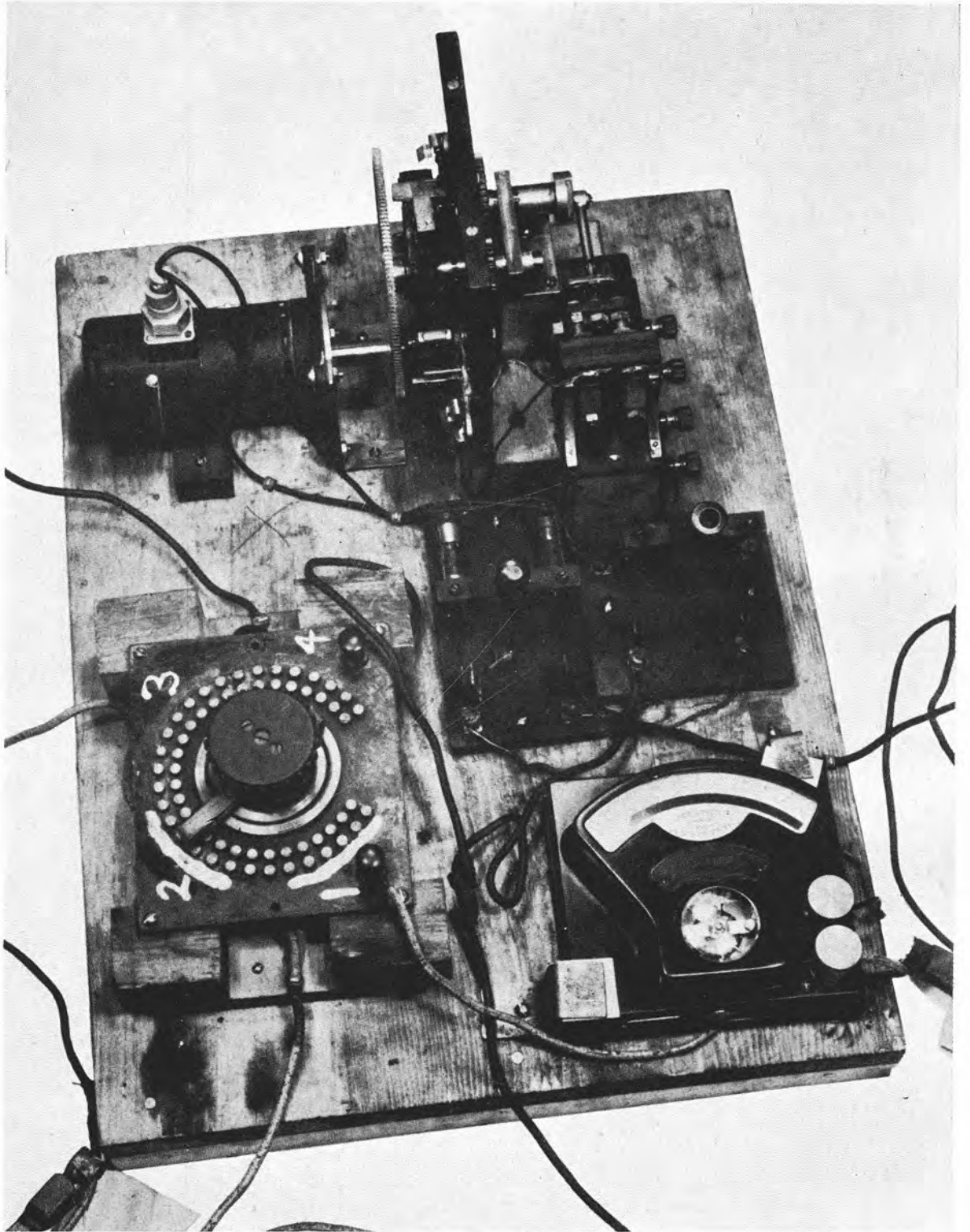

FIGURE 7. Photograph of magnetic eraser switch.



supply (storage batteries). A special switch, Figures 6 and 7, was designed for the purpose which would carry through the erasing cycle at frequencies up to 100 per minute.

Magnetic eraser installations were made on a jeep and an M-5 tank. For some of the coils, advantage was taken of parts of the structure, such as the bumper on a jeep (Figure 8).

Extensive tests were made of the operation of the compass and odograph in the jeep and

mechanical disturbances (welding on the tank, pounding when in different headings, and driving over rough roads). The net effect of these tests is the indication that the magnetic eraser would reduce the disturbance due to semipermanent magnetization and the necessity of re-compensation by approximately 50 per cent.

The magnetic eraser development was carried only far enough to indicate that it had some promise. There was no point to carrying it further until application to a specific vehicle was to be undertaken. A decision to this effect was never made.

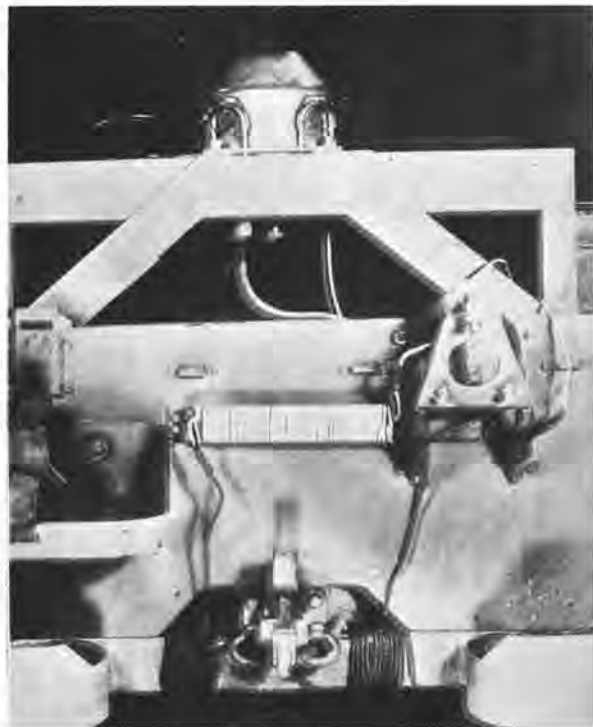

FIGURE 8. Installation of magnetic eraser on jeep.

tank with and without the magnetic eraser operating and with it operating at different frequencies. The operation of the eraser should be better for heavier currents and lower frequencies, but the disturbances to the compass caused directly by the fields of the eraser would be less at lower currents and higher frequencies. As a compromise, the tank installation was operated at about 100 cycles per minute and required an average current of 4 amperes at 12 volts. Maps were made and compass changes determined²¹ with and without the magnetic eraser operating and with the tank subjected to magnetic and

1.3.4

The DTM Compass

The compass described in this section was developed by DTM in 1941-1942 and was manufactured by Monroe in considerable quantity, both for use as a simple vehicular compass and for odograph installations. It became known as the standard compass.

The simplest compass is a pivoted magnet, oriented by the horizontal component of the earth's magnetic field. Consideration of effects of tilting and of shock requires that the moving system be suspended from a single pivot and that it be heavily damped; these requirements led to the development of an instrument, the moving system of which comprises, fundamentally, a magnet system suspended from a single pivot and partially immersed in a damping fluid.

THE SERVOMECHANISM

In order that the compass may actuate the odograph element without any reaction on the compass itself which would disturb its indications, the controlling element of the servomechanism or compass follower is a beam of light from a small lamp, which is reflected from a double mirror carried by the compass (Figure 9) and as indicated schematically in Figure 10. The double mirror, with two surfaces at right angles (see Figure 9), is used so that the light beam is reflected back in the same place as the lamp, independently of the angle between the lamp and the plane of the compass card (which will change with tilt of the vehicle).

The lamp and two flanking photoelectric cells are carried together on a rotatable ring with peripheral teeth through which it is driven by a small pinion connected by a flexible shaft to the odograph. The two photoelectric cells control thyatron tubes (also mounted on the rotating ring); these thyatron tubes control the current through the coils of a magnetic clutch in the odograph integrator. The electric

compass mirror. For example, when light following the dashed lines of the diagram enters the left photocell, the associated thyatron is energized as the other is rendered nonconductive, so that the clutch magnet coil connected to the left thyatron takes control and shifts the clutch to reverse the rotation of the gear train and flexible shaft so that the ring carrying the photocell assembly is now shifted to the left until the right-hand photocell is activated by light reflected from the compass mirror. Then the other clutch magnet takes control as the first is released, the gear train is again reversed, and the cycle repeated.

The result of this arrangement is a continual shifting of the clutch magnets and oscillation of the ring carrying the lamp and phototubes back and forth, so that alternately one and then the other of the phototubes receives light reflected from the compass mirror. In the land vehicle installation, the angle of rotation between the positions of reversal is approximately 10 degrees, and the frequency of this oscillation or hunting is approximately 75 complete cycles per minute. It is evident that, if the compass card is rotated relative to the case by a change in heading of the vehicle, the center of oscillation of the ring will shift along with the position of the compass, so that the outer ring continuously oscillates or hunts about an average position controlled by the position of the compass itself. It is further evident that, since the power is derived from the motor and associated magnetic clutches, the torque available to drive the compass follower carrying the photocells and any other connected apparatus, particularly the sine disk of the integrator element, is limited only by the design of the mechanical system, and does not in any way disturb the compass needle itself, for its only connection to the mechanical system is through the beam of light reflected from its mirror.

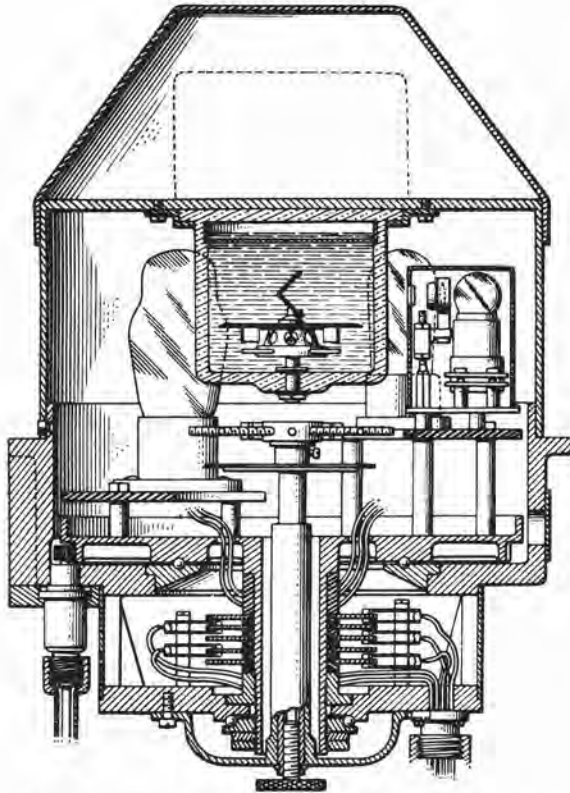

FIGURE 9. Section of standard compass showing lamp and mirror system.

connections are such that, after one of the photoelectric cells has been activated by reflection of light upon it, current continues to pass through the associated thyatron and clutch coil until the other cell is activated. The relation of the clutch and associated motor-driven gearing (Figure 10) is such that, when light falls on one phototube and activates the associated thyatron and clutch magnet, the entire ring assembly carrying photocells and lamp is rotated so that it brings the other photocell toward the beam of light reflected from the

THE COMPENSATING SYSTEM

The compensating system of the compass assembly is shown particularly by previously mentioned Figures 4 and 5. The variable parts of the permanent magnetic fields required are produced and conveniently adjusted by pairs of permanent magnets, each rotatable and geared

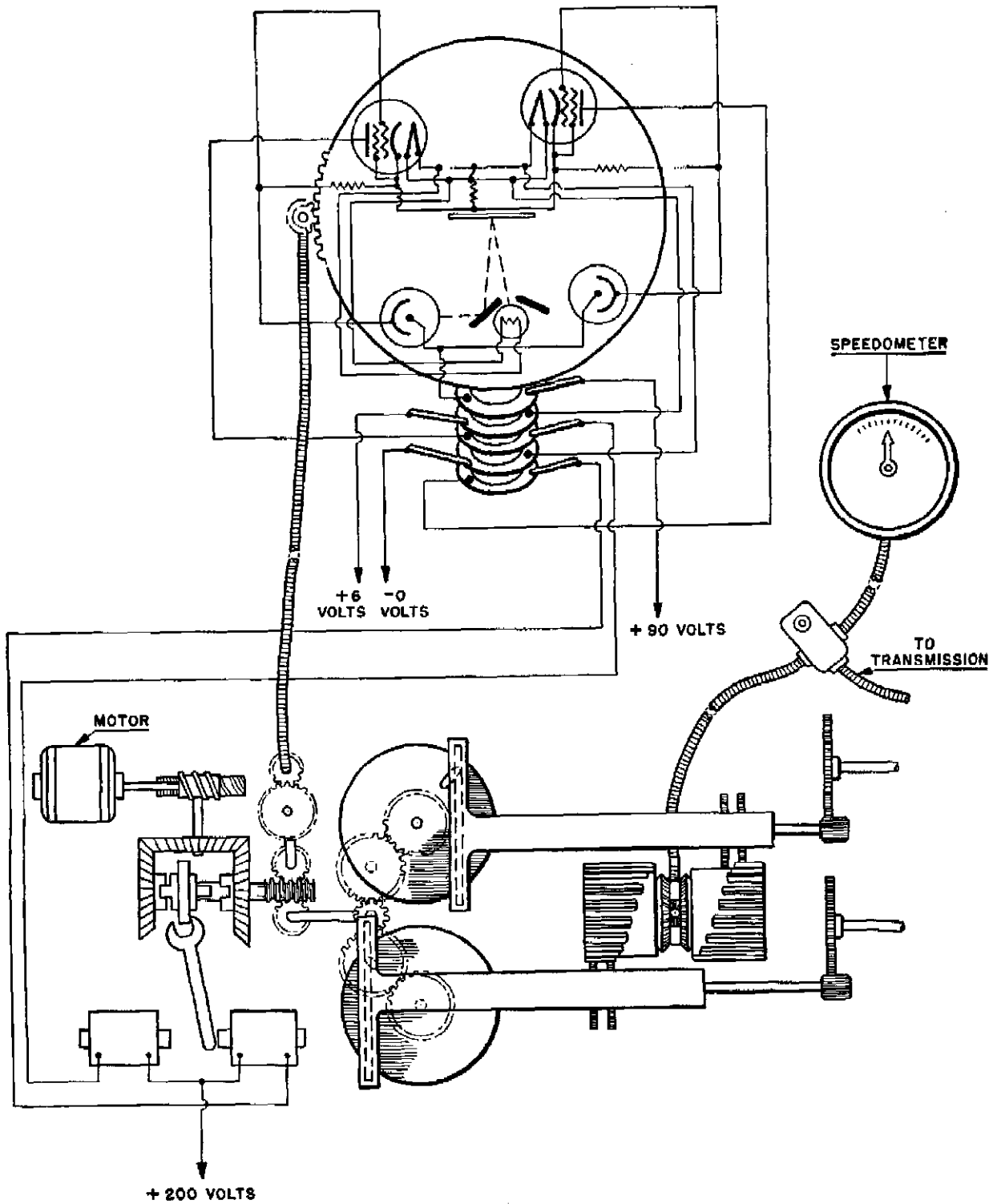

FIGURE 10. Compass and integrating mechanism in combination.

~~CONFIDENTIAL~~

together so that, as they are adjusted, the two magnets of a pair rotate in opposite directions. This serves to produce a magnetic field which is variable in strength but constant in direction, as the moment but not the orientation of

chamber, 2, which holds vertical bar magnets; two rotatable pairs of magnets, 4, for fine adjustment of N-S and E-W horizontal compensations; a rotatable pair, 1, for fine adjustment of vertical compensation; an 8-armed spider, 5,

RUNS WITH MONROE UNIT

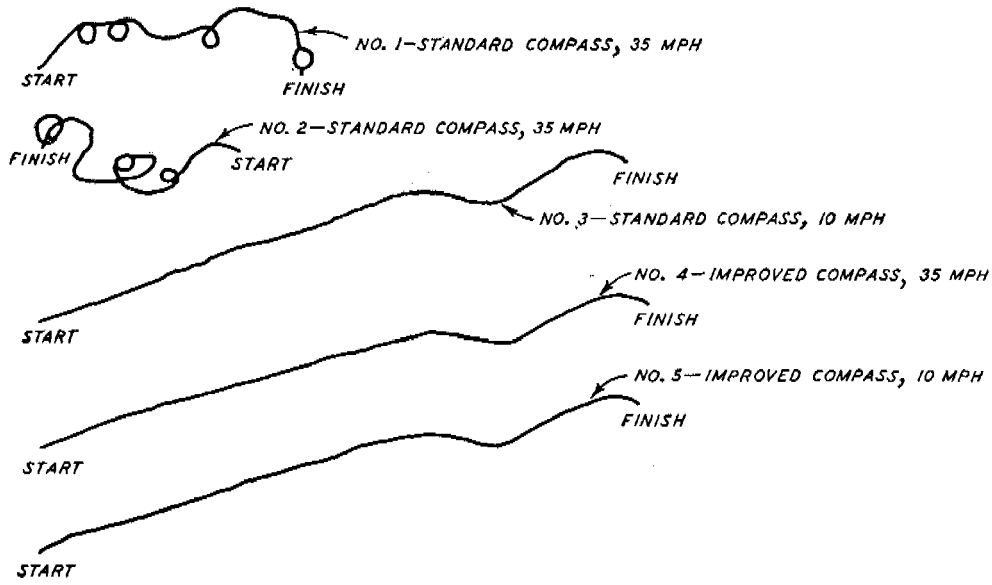

RUNS WITH IBM UNIT

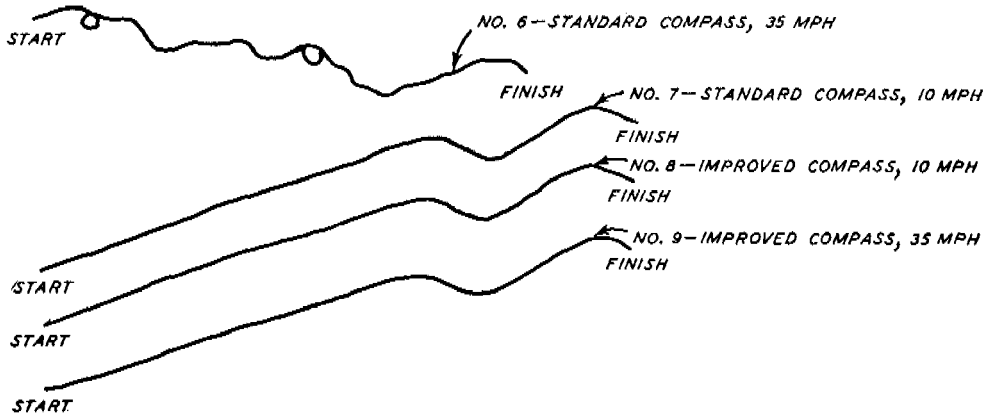

FIGURE 11. Odograph records for comparison of standard and improved compass. Traces are for run of 1.6 miles over rough corduroy road.

the resultant magnet formed by the combination of the two is varied when the two are rotated in this manner. The compensating system includes: a small drawer, 3, Figure 4, which holds N-S and E-W horizontal bar magnets; a

carrying Permalloy collars, 7, for quadrantal compensation.

Approximate compensation for permanent magnetization is made by placing a proper combination of small bar magnets in the drawer



and in the vertical chamber and making the fine adjustments with the rotatable pairs or screw-type compensators. Quadrantal compensation is made by adjusting the position and number of Permalloy collars on the arms of the spider. The entire compensation procedure is rather complicated, requiring making a certain systematic series of readings and recordings of deviations in various headings of the vehicle. For routine use, forms are supplied on which the various steps and recordings are clearly indicated (some 55 entries^{35a}) so that relatively untrained personnel can carry out the necessary procedure.

1.3.5 Reduction of Vibration Effects on Compasses

The first model of the so-called standard vehicular odograph compass had part of the moving mechanism suspended in a damping liquid. It was found that this compass was very severely affected by strong vibration of the vehicle, such as might be encountered, for instance, in driving a jeep over a corduroy road. This effect is due to purely mechanical effects resulting largely from asymmetrical force components caused by the reaction of swirling damping fluid on the moving system such that, when violently agitated, the compass would be turned far from its proper azimuth and, in some cases, would make one or more complete revolutions. Tests were made^{15c} of various types of antivibration or shockproof mountings of the compass itself, but none was found which did not transmit vibrations at some speed of the vehicle which very seriously affected the compass performance, and it was found that better overall results were obtained when the compass was mounted rigidly on the vehicle. An improved model of the compass was then developed in which the damping vanes were redesigned to eliminate the asymmetrical forces and in which most of the weight of the moving system was buoyed up by the liquid in the damping-fluid chamber. This led to very greatly improved performance of the compass and corresponding odograph traces in tests over rough roads (see Figure 11). It was this last improve-

ment that finally gave a magnetic compass which could be quite satisfactorily applied to an odograph installation on ground vehicles.

It may be reiterated here that, no matter how perfect the compass itself may be, it is subject to limitations imposed by any instability of its magnetic environment and consequent requirements of recompensation resulting primarily from subpermanent magnetization. It is these limitations which make it seem entirely impossible to attain the limit of precision in odograph maps of the order of 1 in 300, which was set at the time of the original suggestions by the military, but performance approaching a precision of 1 in 100 can be regularly obtained in all but the most severe circumstances.

1.3.6 The General Motors Inductor Compass

The General Motors project for the development of a compass was set up, at the request of the Army, to produce an alternative compass for use on land vehicles which would operate on different principles from the standard compass and which might, if necessary, lead to an alternative source of supply.

PRINCIPLES OF OPERATION

The instrument as developed consists of an inductor-type element responsive to the earth's magnetic field together with a servomechanism which keeps the sensitive element oriented into the position of zero output, that is, a position perpendicular to the magnetic field. The output of the servomechanism can be connected to the standard vehicular odograph.

The principle of operation of the sensitive element is indicated by Figures 12 and 13. The direction-sensitive element consists of two primary coils, *L-1* and *L-2*, Figure 12, wound in opposite directions upon a Mu-metal core, *M*, with a single secondary coil, *L-3*. The operation depends upon the fact that the Mu-metal core becomes magnetically saturated for small fields and therefore is completely saturated for each half cycle of the primary magnetizing current, as indicated by Figure 13. The voltage induced in the secondary coil depends upon the change

of flux in the Mu-metal core. If there is no external magnetizing field, the change in flux in the two halves of the coil within the primary windings $L-1$ and $L-2$ is about a zero position, which is symmetrical with respect to the two sides of the magnetization curve ($\Delta\phi_1$ and $\Delta\phi_1'$, Figure 13, are equal), so that the voltages induced in the secondary coil, $L-3$, by the two primary coils, are equal and opposite and the output voltage in $L-3$ is zero. However, if there is a magnetic field which affects the Mu-metal core,

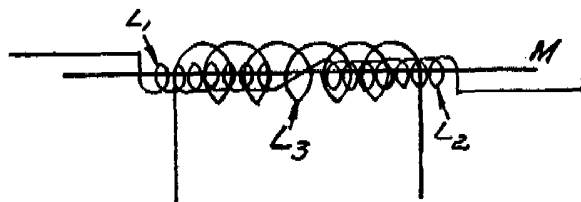

FIGURE 12. Principle of direction-sensitive head, inductor compass.

the axis about which the magnetization takes place is displaced toward one side or the other of the magnetization curve (say to the dashed horizontal line of Figure 13), so that the range of magnetization from the axis to saturation is different in the two primary coils ($\Delta\phi_2$ and $\Delta\phi_2'$ are different); the induced voltages in the two halves of the secondary coil no longer balance, so that there is a net output in the secondary coil, $L-3$. The magnetic characteristics of Mu-metal are such that a field of the order of magnitude of that of the earth will magnetize it to a considerable fraction of saturation. For this reason, the output voltage in the coil, $L-3$, is responsive to the orientation of the Mu-metal core with respect to the earth's field; the magnitude of the voltage of $L-3$ depends upon the azimuth of the core with respect to the magnetic meridian, and the phase of this voltage with respect to the exciting current in coils $L-1$ and $L-2$ reverses when the direction of magnetization of the Mu-metal core reverses. Therefore, the output of the coil $L-3$ passes through zero and changes sign as the Mu-metal core is oriented through the magnetic E-W direction.

THE SERVOMECHANISM

If a servomechanism is provided which is responsive to the output of the secondary coil in

such a way that it orients the sensitive element in the direction to give zero output, the compass element will be maintained in a magnetic E-W direction. Power derived from the servomechanism can then be used to drive the azimuth element of an odograph integrator and the compass will give the proper direction control to the odograph. The direction-sensitive head containing the Mu-metal bar is suspended on gimbals in a damping fluid with the suspension being carried on a rotatable head driven by the servomechanism. Electric contacts to the sensitive element are carried through slip rings.

The servomechanism as developed for this instrument is a moderately elaborate device^{24a} which involves an amplifier and thyatron tubes

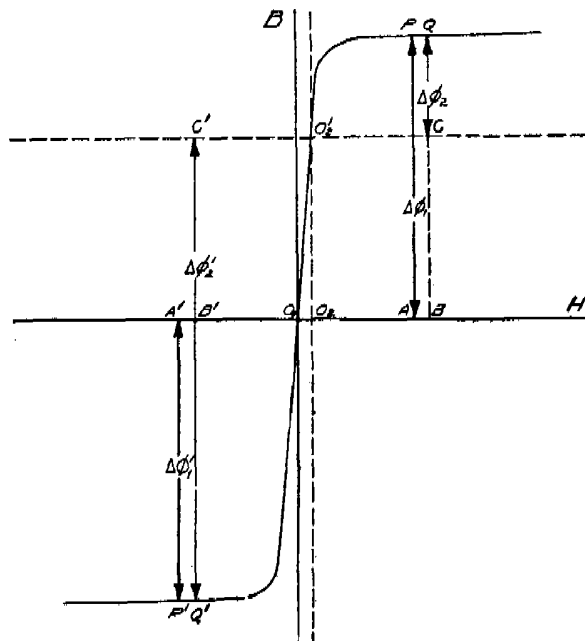

FIGURE 13. Magnetization curve for Mu-metal core of direction-sensitive head.

which control coils of electromagnetic clutches. The proper phase and time relations between the output of the compass element and the thyatron tubes are obtained through a motor-driven multiple contactor which controls the primary current in coils $L-1$ and $L-2$ and the grids of the thyatron tubes, so that, when the direction of magnetization of the Mu-metal core (and therefore the phase of the output voltage with respect to the primary current) is in one direction, one of the thyatron tubes is

operated, and, when the phase of the output voltage is reversed, the other is operated. Thus, when the azimuth of the direction-sensitive head is off on one side from an E-W direction, one of the thyatron tubes is conducting, and, when it is off on the other side, the other tube is conducting. The outputs of these thyatron tubes energize the coils of electromagnetic clutches.

The manner in which the thyatron outputs control the position of the sensitive head is indicated schematically in Figure 14. This figure does not correspond with the actual mechanical

wards the correct E-W position. However, since the response of the mechanism is not instantaneous, the rotation will overshoot the E-W position where the output voltage is zero, so that the other thyatron tube is activated (and the first is deactivated because the arrangement of the motor-driven contact is such that both tubes cannot be conducting at the same time). Clutch coil *S* is energized and a mechanical connection is made through the associated clutch disks so that now the flexible shaft is rotated in the opposite direction. Thus the mechanism is such that the sensitive element is

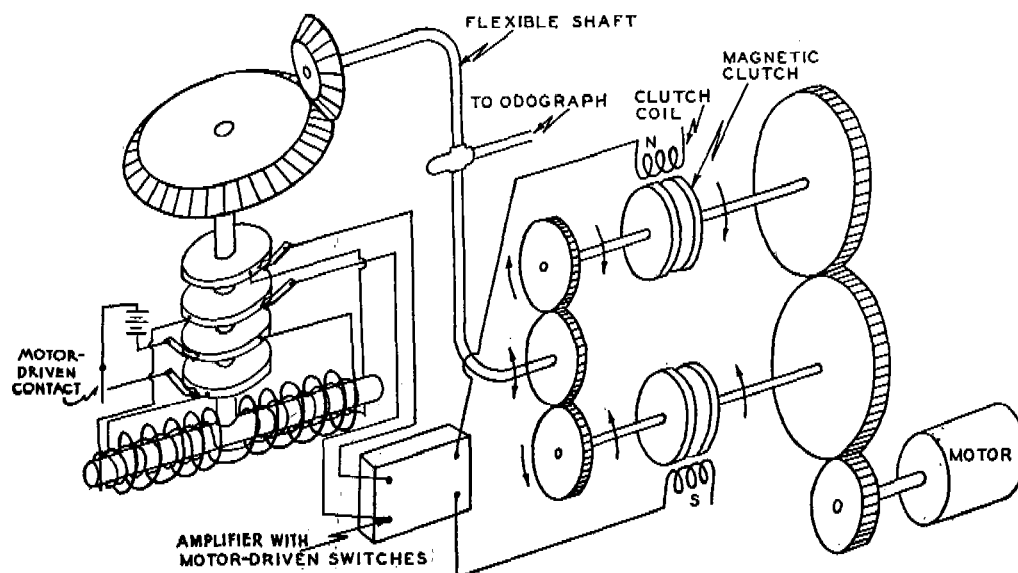

FIGURE 14. Principle of servo mechanism for inductor compass.

arrangement used but is intended only to indicate the general principles of the mechanical coupling by means of which the servomechanism operates.

Let us assume that, when the east-pointing end of the sensitive element is off towards the north from its normal position perpendicular to the magnetic meridian, the phasing of the output is such that the thyatron tube connected to the clutch coil *N* (Figure 14) is active. Then the rotation of the gears is such that, when the mechanical connection is made through the clutch disks under coil *N*, the flexible shaft is turned in a direction which will rotate the east end of the coil towards the south or back to-

always turned back towards an E-W position and hunts about that position. This is the requirement for driving the azimuth element of the odometer so that, if a connection is made from the output gearing (through another flexible shaft) such that the position of this shaft bears a fixed relation to the shaft controlling the orientation of the sensitive head, and therefore to the magnetic meridian, it can be used to control the azimuth element in the odometer.

Figure 15 shows the sensitive head as hung on gimbals with the damping vanes. The entire suspended assembly hangs in a small tank of kerosene.

Figure 16 shows the sensitive head as developed for mounting in the standard compass case.

PERFORMANCE TESTS

A very extensive series of performance tests²⁴ was made of the inductor compass connected with the standard IBM vehicular odo-

far from satisfactory. The inductor compass and the improved DTM compass both gave much better results at high speeds, with the

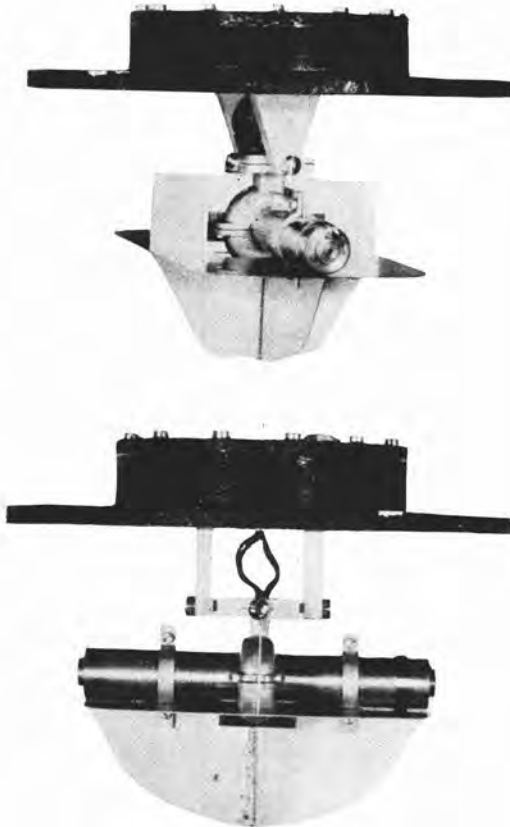

FIGURE 15. Photographs of sensitive head of inductor compass, showing suspending gimbals and damping vanes.

graph (ratchet drive) on a 1/4-ton 4x4 truck and on a M3A1 light tank. Comparative runs were made at low, medium, and high speeds with the inductor compass, the standard M-1 compass, and the improved DTM compass previously described (Section 1.3.4). These tests indicated that at low speeds all three compasses gave reasonably satisfactory results. At medium speeds, the standard M-1 compass began to fail and at high speeds and rough travel was



FIGURE 16. Inductor-type compass as developed for mounting in standard compass case. *Upper*, cover removed; *lower*, closed, as in use.

results from the inductor compass apparently somewhat superior (see maps, Figures 17, 18, and 19).

In tests with the light tank,²³ the inductor

compass was mounted in three external positions at heights of 25 in., 10 in., and 6 in. from the armor of the tank. These tests indicated

in., performance was almost as good as with a height of 25 in. and that this performance was generally satisfactory, as maps made with the

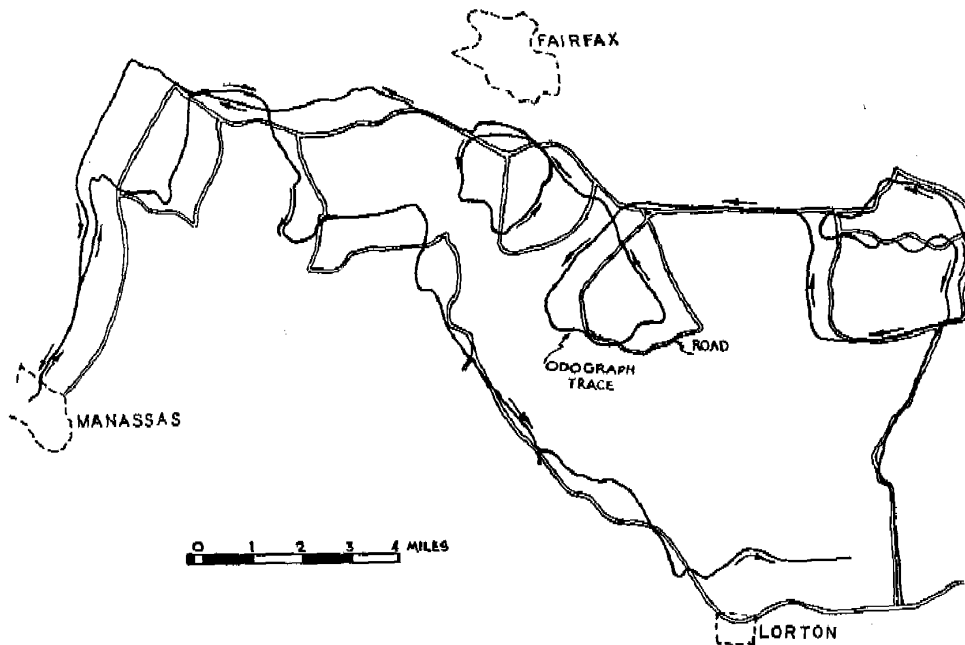

FIGURE 17. Odograph test run in $\frac{1}{4}$ -ton 4x4 truck (jeep), with inductor compass; 30-35 mph, moderately rough roads.

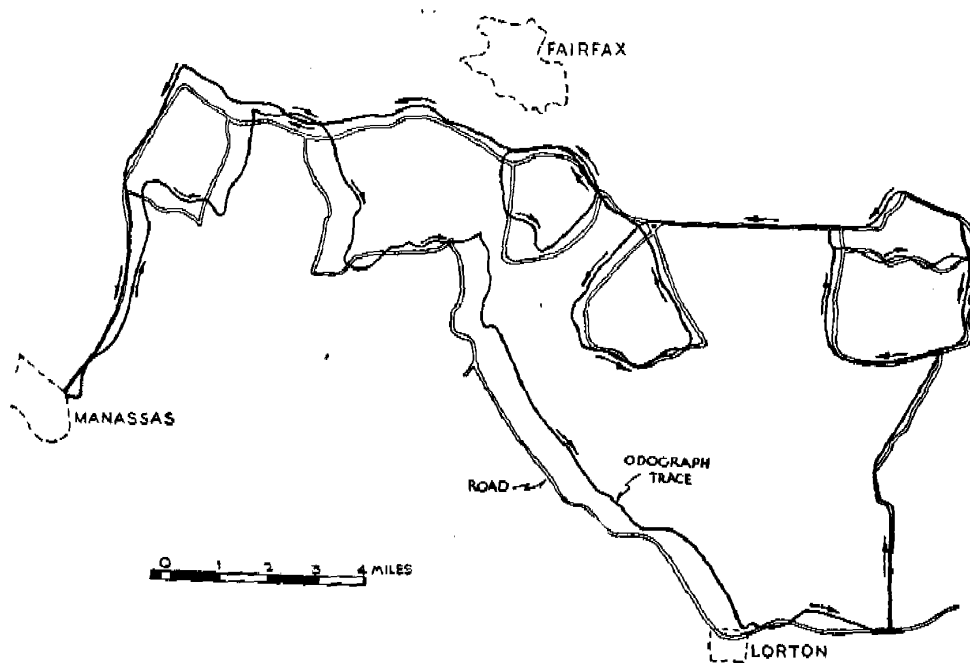

FIGURE 18. Odograph test run in jeep, improved DTM compass, 30-35 mph. Same route as Figure 17.

satisfactory compensation could not be maintained when the compass was as close as 6 in. from the armor, but that, with a height of 10

compass in the 10-in. position were consistently under 3 per cent in error. Figure 20 shows a test run with the inductor compass in the 10-in.

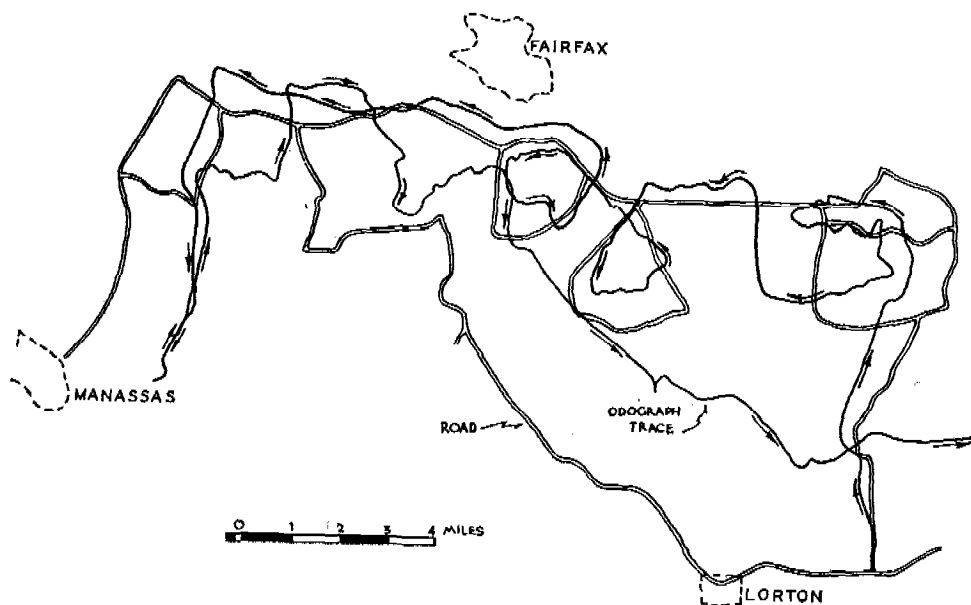

FIGURE 19. Odograph test run in jeep, standard M-1 compass, 30-35 mph. Same route as Figure 17.

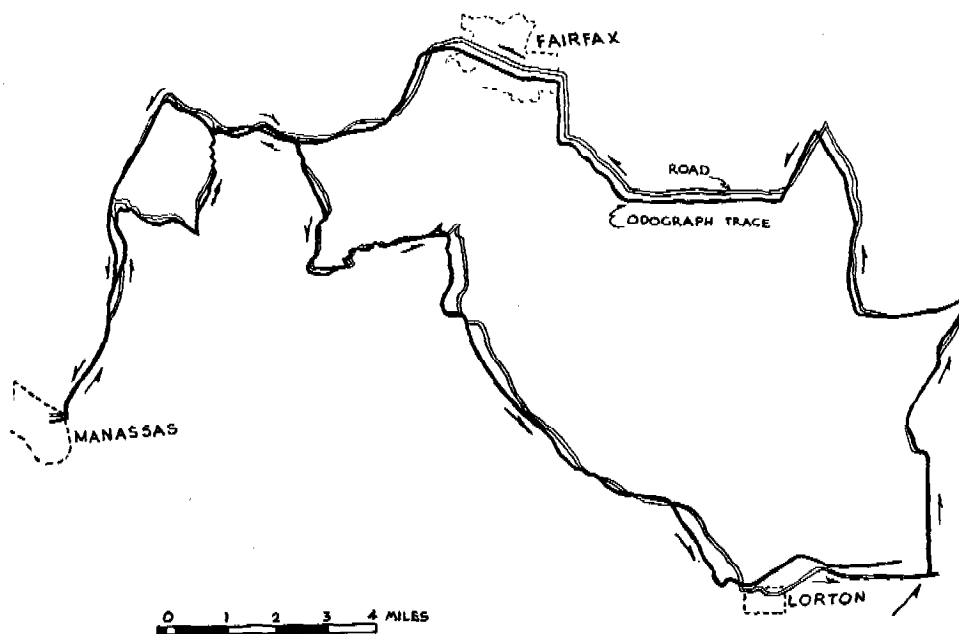

FIGURE 20. Odograph test run in M3A1 light tank. Inductor compass outside tank, 10 in. above armor.

position, with the roads over which the run was actually made traced on the same map.

1.3.7 The Gyrostabilized Fluxgate Compass

This is a commercial instrument, developed by the Pioneer Instrument Company for other purposes and is not a part of this OSRD project.

(each of the three arms of the triangle is, in principle, similar to the sensitive element of the GM inductor compass). The three windings are symmetrical, so that, if no external magnetic field traverses the Mu-metal core, the voltage in each of the three secondary windings is zero and there is no output. If, however, the sensitive element is traversed by a magnetic field, voltages are induced in each of the three secondary coils, and the magnitude and phase of these voltages vary, depending upon the direction of

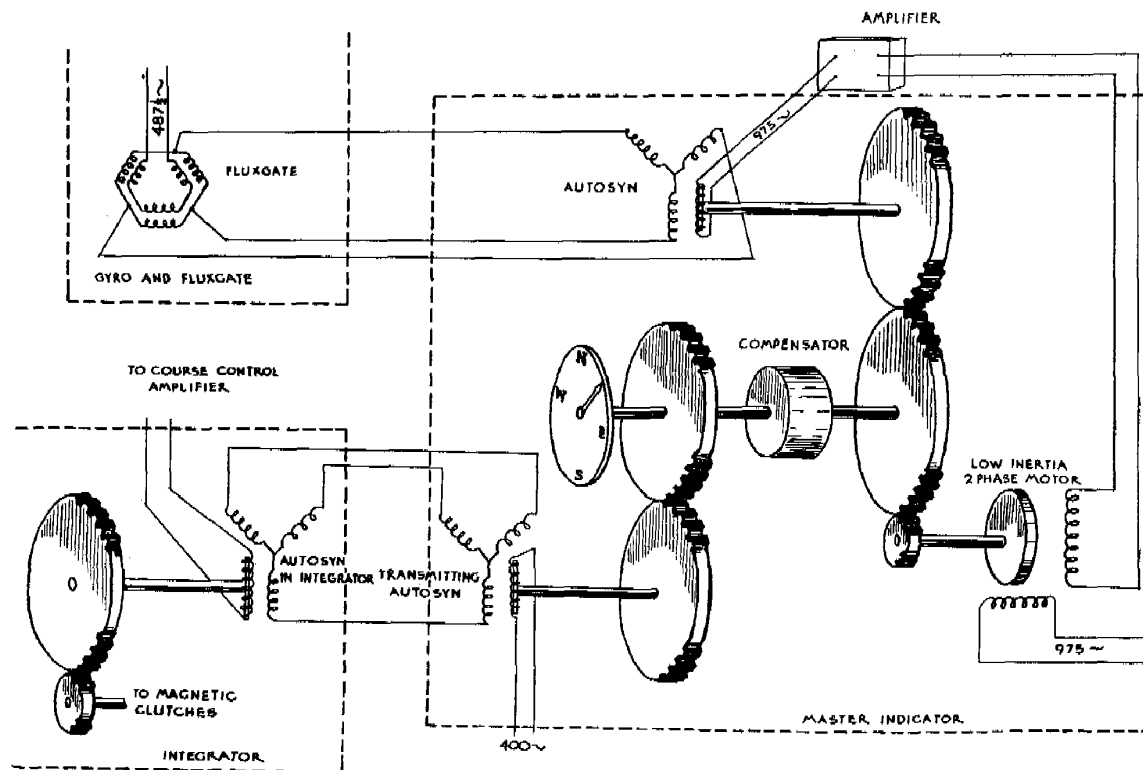

FIGURE 21. Schematic drawing of operating principle of fluxgate compass system.

However, since it became an essential part of the airborne applications, a brief explanation of its principles is included to show how it operated and was connected in with equipment developed by the OSRD to make the complete airborne odograph.

PRINCIPLES OF OPERATION

The primary magnetically sensitive element of this compass (Figure 21) is a triangular frame of high-permeability (Mu-metal) material with each of the three sides carrying a double primary and single secondary winding

the magnetic field with respect to the three sides of the triangle. Thus, if the assembly is held in a horizontal plane, the phase and magnitude of the output voltages in the three-phase system are dependent upon the direction of the horizontal component of the earth's magnetic field with respect to the three coils.

The magnetically responsive fluxgate unit is held in a horizontal position by a specially constructed gyroscope which contains an automatic and continuously active erecting device such that, at all times, the gyroscope tends to maintain a vertical axis so that the magnetically

sensitive element is acted upon only by the horizontal component of the earth's magnetic field. The output of the fluxgate element is connected by means of a servomechanism (operating on the autosyn principle) to a master indicator, the pointer of which is driven by a small, two-phase, low-inertia motor, one phase of which is excited by the amplified output of the autosyn rotor. The motor is mechanically connected to the rotor in such a way that it tends to turn it back to the position of zero output, when the excitation of one phase of the motor field drops to zero and the motor stops. This action serves to maintain a fixed relation between the pointer and the output from the fluxgate element such that the direction of the pointer corresponds with the direction of the magnetic field through the fluxgate coils. The master indicator motor also controls the position of the rotor of a magnesyn to which another magnesyn at another location can be connected, thus serving as a repeater by which the position of the master indicator can be shown at one or more other locations. As described in the section on the airborne odograph (Section 1.5.4), there is an autosyn within the integrator, connected to the master indicator, which controls a servomechanism driving the direction elements of the integrator.

The fluxgate compass system contains within its master indicator an arrangement by which compensation for inaccuracies in compass indication can be made mechanically. This is done by a series of screws at 15-degree intervals in a ring around the indicator. By adjusting these screws, the form of a cam surface is adjusted, and a follower on this surface modifies the coupling between the primary direction element and the indicator in such a way that ordinary deviations of the compass from its correct indication can be compensated. For this reason, it is not necessary ordinarily to make adjustments of the magnetic environment of the compass element itself to take care of fixed or induced fields, but their effect in disturbing the compass indication is taken care of at the master indicator by adjustment of the compensation ring.

Performance tests of several airborne odograph units connected with the gyro-stabilized fluxgate compass are included in Section 1.6.

1.4 TRUE MILEAGE AND SPEED DEVICES

1.4.1 Introduction

When making odograph installations in aircraft or on boats, it is necessary to provide an accurate log (distance) or speed unit which will take the place of the speedometer shaft used for the distance element in land vehicle installations. For air- and water-driven devices, no appreciable power can be drawn from the primary element actuated by motion through the air or water, as any drag would affect the speed or distance indication. Therefore, all air or marine logs or speedometers require some sort of follower or servomechanism from which power to operate the odograph may be drawn.

Some of the devices described in this section were developed entirely outside the odograph project but were adopted as essential parts, particularly of airborne installations. The descriptions of such devices included herein are brief and are intended only to indicate their principles and methods of operation so as to clarify their function in the installations of which they became essential parts.

1.4.2 True Air Mileage Devices

Various types of air mileage devices have been considered in connection with the airborne odograph. The usual airspeed indicator as used on airplanes uses a pitot tube which operates on the difference between the pressure in a tube opening forward into the airstream and the static air pressure. This pressure difference, and consequently the airspeed indication, is dependent upon the air density as well as on the speed of the plane through the air (but this is a satisfactory instrument from the pilot's viewpoint because the performance of the plane depends on this indicated airspeed rather than the true airspeed). To make a true airspeed indicator, some other device must be used or the simple airspeed indications must be corrected to take account of the variable density and temperature of the air.

THE SIMPLE IMPELLER LOG

This device consists of a fan or blade rotated by motion through the air so that the impeller acts like a screw, and the amount of rotation is directly proportional to the distance moved. Of course, no power can be drawn from the rotating member itself, but it is possible to actuate electric contacts or other electric controls in such a way that the speed of a motor or other parts from which power can be drawn is regulated by the rate of rotation of the impeller. Extensive tests of such a device¹⁷ indicated that it is quite satisfactory for moderate airspeeds, such as are encountered in lighter-than-air craft, but that it encounters serious difficulties due to air drag for very high speeds, such as are met in modern planes.

THE SCHWIEN TRUE AIRSPEED METER

This instrument^b is a modified pitot tube-type airspeed indicator which contains a system of levers and pressure- and temperature-responsive elements so arranged that corrections for air density and temperature are automatically made and the indicator shows true airspeed rather than pitot tube pressure. This instrument was originally designed as an indicator only. In order to apply it to the odograph, a pickup was made by arranging a potentiometer around the face of the instrument.¹⁸ A motor-driven contact element is mechanically moved in and out at short time intervals, so that the indicator pointer serves as the movable contact on the potentiometer, and the voltage between this contact and one end of the potentiometer is proportional to the true airspeed. By means of electronic circuits and a servomechanism, this voltage is balanced with that of a similar potentiometer in the odograph integrator, and the position of this balance controls the speed of drive of the indicator disks so that this speed is proportional to the true airspeed.

THE BRITISH AIR MILEAGE UNIT

In this instrument,^c the pitot tube pressure is balanced against pressure supplied by a motor-

^b This device was not developed as part of the odograph project but was modified somewhat and used in some of the earlier airborne odograph installations.

^c Not developed as part of this odograph project but used for many airborne installations.

driven blower. The pitot tube pressure acts on one side of a diaphragm, and the pressure from the motor-driven blower acts on the other side. The air input to the blower is taken from outside the ship, and also an arrangement is made so that this air is swept over the fan and other parts of the device. Thus the temperature and pressure of the air operated on by the blower are the same as those of the air which gives the pitot tube pressure. Then the pitot tube pressure on one side of the diaphragm and the pressure from the blower air on the other side are subject to the same laws of variation with temperature and pressure, and, consequently, the speed of the blower required to furnish the same pressure as that given by the pitot tube is directly proportional to the airspeed. Thus, if a servomechanism is arranged to regulate the motor speed so that the diaphragm is kept balanced, this speed will be directly proportional to the airspeed of the plane, and the blower motor can be connected directly to the speed unit of the odograph. Certain adjustments in the operating position and a spring bias on the diaphragm are provided to correct for systematic discrepancies in performance, and the setting of these adjustments is made in calibrating the device.

THE PIONEER PUMP UNIT

This device^d is similar in general principle to the British air mileage unit except that in this device the pitot tube pressure and pump pressure operate on separate diaphragms which are connected by a linkage unit. This unit controls circuits governing the motor speed and provides adjustments for making corrections for certain systematic inaccuracies.

1.4.3 Comparison of Airspeed Meters for Odograph Installations

Calibrations and comparative tests indicated that both the Schwien true airspeed indicator and the British air mileage unit gave fairly satisfactory results and came within 1 or 2 per cent of correct airspeeds in ranges from about

^d Not developed as part of the odograph project but used in some aircraft installations.

60 to 300 mph. Since the pitot tube pressure is proportional to the square of the speed, devices of this kind are inherently unsuited to a wide speed range and become poor in the lower ranges. The overall performance of the Pioneer unit was somewhat less satisfactory than that of the British unit. From the standpoint of direct applicability, the British and Pioneer units are parallel in that they each have a motor which rotates at a rate proportional to airspeed and this motor can be connected directly to the odograph. The Schwien instrument is somewhat simpler in its operation but requires an additional unit (the potentiometer and associated electronic controls) to permit operation of an

through the water. The water log as developed for the odograph application¹⁸ uses a screw (like a small propeller) driven by motion through the water together with a servomechanism by which a motor is controlled to rotate at a rate proportional to that of the screw without drawing enough power from the screw to affect its rate of rotation.

A rather difficult problem arises in finding a suitable position for the screw both from the standpoint of damage to the screw, which may result by striking bottom or docks, as when landing, and from the standpoint of eddies and cavitation, which would affect its indication. Some work was done in developing a retractable

TABLE 1. Comparative summary of airspeed devices.

Item	<i>Schwien</i>	Unit <i>British</i>	<i>Pioneer</i>
Average error in flight (per cent)	1	1	3
Reliability	Good	Good	Poor
Calibration and compensation	None possible	Laboratory calibration necessary	
Range (knots)	50-300	60-300	100-480
Voltage requirements (volts)	None	24-28 dc	24-28 dc
Approximate weight exclusive of cables and connections (lb)			26 or 115, 400-c
Installation	2 Easy, location not critical	17 Position critical with respect to skin of ship	10 Critical to operation
Vibration		Not seriously affected	
Temperature compensation	Rapid, accurate		Slow in response
Adaptability to odograph as regards integrator	Additional components needed complicate design		Readily adaptable to fundamental design
Availability	No production		Extensive production

odograph. For this reason, and also because the British air mileage units were available while a Schwien unit was not so readily available, the British unit was used for most airborne odograph installations. A general comparison of the various airspeed units and their applicability to odograph installations is shown by Table 1.^{17a} The reasons for the adoption of the British unit for most aircraft odograph installations are evident from the factors indicated by this table.

1.4.4

Sea Logs

In using an odograph on boats, the problem arises of devising a suitable device to give the distance traveled or rate of travel of the boat

screw which would be released by a trigger mechanism with the trigger ahead of the screw, so that it would be pulled quickly out of the way when the trigger is struck, thus preventing damage by striking an underwater object. This was fairly successful for low and moderate speeds but was difficult for application to high-speed boats because of the short time available for clearance after the trigger is actuated and the disturbance to the stream lines caused by the trigger mechanism itself.

The problem of suitably locating a water log was a special one for each craft to which the odograph was fitted.

SERVOMECHANISMS

Ratchet Motor. One of the most useful of the servomechanisms used to give an indication

proportional to the rate of rotation of the screw was a ratchet motor controlled by electric contacts driven by the log unit.¹² Contacts operated by the ratchet motor controlled another motor from which power could be taken to drive the odograph.

Frequency Meter. Another development within this general project was that of a marine speedometer which was designed primarily as a speed indicator rather than as a part of an odograph installation. A simple electric circuit for this purpose uses a saturated transformer in which the induction in the secondary is proportional to the frequency of interruption of the primary current.¹⁰ A relay which is operated at a frequency controlled by a contactor on the rotating screw carries contacts which interrupt the primary of the transformer and also rectify the secondary output so that a simple direct-current meter has a deflection proportional to the speed of rotation of the screw.

*Variable-Frequency Synchronous Motor System.*¹⁵ A rather elegant system, developed to the experimental stage, was that using a two-phase generator and motor. The generator rotor, turned by an impeller in the fluid stream, generates very low-power, two-phase current at a frequency proportional to the rate of rotation. Each phase is amplified separately (to a power output of about 25 watts), and these outputs are supplied to a two-phase motor to drive the odograph or other apparatus.

The electrical complications and the comparatively large weight and power requirements prevented any extensive applications of this system.

as its output the distance traveled resolved into cardinal components, so that the sums of all motions of the vehicle parallel to the reference direction and perpendicular to that direction are continuously shown. This means that each of these components of motion must operate one of a pair of elements within the integrator which is moved or turned by increments which, at all times, are proportional to the increments of travel parallel to the reference direction (normally N-S) and perpendicular to the reference direction (normally E-W); i.e., the increments must be added up as $\Delta s \cos \alpha$ and $\Delta s \sin \alpha$, where Δs is the increment of distance and α is the angle between the instantaneous direction of motion and the reference direction. This means that some sort of continuously variable coupling must be used to provide the varying degree by which each element of motion of the vehicle is projected onto the reference axes. The motion or turning of mechanical elements satisfying these conditions may be caused to actuate counters by which the increments of N-S and E-W components of the motion of the vehicle are added from the initial starting point so that each of the two horizontal coordinates of instantaneous position is continuously indicated. Also, the same increments can be transferred to two perpendicular screws controlling the motion of a pencil or marking device so that one screw gives the N-S position and the other the E-W position. Then the position of the pencil on the marking table corresponds, at all times, to the position of the vehicle on the ground. If the plotting table over which the pencil moves carries a map and the scale of the motion of the pencil is properly adjusted to the scale of the map on the table, the motion of the pencil will trace a line on the map which corresponds to the course traveled by the vehicle over the ground.

1.5 ODOGRAPH INTEGRATORS

1.5.1 General Requirements of Odograph Integrators

Before describing the mechanical parts and operations of the several integrators which were developed, it will be useful to review the general requirements and functions which are common to all of them.

The integrator must take as its input either distance or speed and direction and must give

THE SCOTCH YOKE

A simple mechanical principle which serves to give motions proportional to $\sin \alpha$ (or $\cos \alpha$) is the Scotch Yoke, and it or its equivalent is used in each of the three integrators described in this section. The principle of the Scotch Yoke, as shown in Figure 22, consists essentially of a disk carrying a pin or roller which

slides or rolls within the slot of the yoke. This slot has a fixed azimuth or direction and is long enough to permit the pin to travel back and forth in the slot so that the motion of the yoke corresponds to the projection of the motion of the pin (or roller) onto a diameter perpendicular to the direction of the slot.

It is evident that the position of the bar carried by the yoke is directly proportional to the sine of the angular position of the disk carrying the pin (which is referred to as the sine

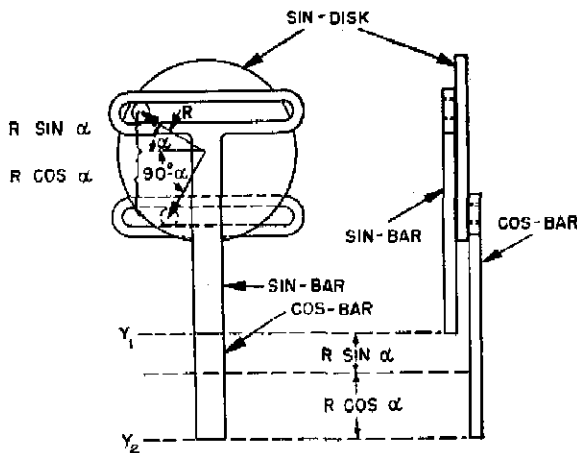

FIGURE 22. Schematic diagram showing principle of Scotch Yoke.

disk). If there is a second pin on the other side of the disk (as shown in the figure) or on a separate disk but at an angle of 90 degrees with the first and operating in a similar Scotch Yoke, it is evident that this second Scotch Yoke will have a position proportional to the cosine of the angle of the sine disk. If means are provided by which the rotary motion of the odograph element is variably coupled to driven elements with the degree of coupling proportional to the positions of the Scotch Yokes, Y_1 and Y_2 , Figure 22, the motion of the driven elements will then be proportional to the amount of travel of the vehicle multiplied by the sine and by the cosine of the angle of the sine disk or disks carrying the pins. If the position of the sine disk is controlled by the compass, then the requirement that the motion of the driven element is proportional to the motion of the vehicle times the sine (or cosine) of the angle of heading will be fulfilled.

Any mechanical or electrical principle which provides that the degree of coupling between a driving and a driven unit is proportional to a linear displacement, such as is provided by the bar of a Scotch Yoke, could be made the basis of an integrating unit. Several such principles have been applied in various machines and instruments. Some of these use a frictional coupling between a fixed driving member and a movable driven member, the position of which, with respect to the driving member, is varied. Others use a positive drive through gears or ratchets. It is evident that, in odograph applications, it is essential that careful consideration be given to the effect which violent motion or shock might have on the mechanical elements involved, and that preference be given to positive drive units over those using friction drives when conditions are very severe, such as on rough-riding land vehicles, particularly tanks, but that a friction drive device might be satisfactory under less severe operating circumstances, such as aircraft or boat applications.

1.5.2 The DTM Experimental Integrator

The original model of this integrator was developed by the Department of Terrestrial Magnetism of the Carnegie Institution of Washington and was built up largely from parts and gears of Monroe calculating machines. The experimental model was taken over later by the Monroe Company and redesigned and engineered for quantity manufacture.

THE STEPPED TOOTH GEAR VARIABLE COUPLING

The essential variable coupling element of this integrator is a pair of gears with stepped teeth, Figure 23. The length of the teeth along the face of the gears varies from a very short tooth to a tooth running entirely across the gear face, the ends of the teeth forming a one-turn spiral (also see Figure 10). The two similar gears are rotated in opposite directions by gears connected directly to the odometer element (speedometer cable). Each of these gears engages a driven gear which is moved parallel to the axis of the driving gears by a Scotch Yoke.

It is evident that, if this driven gear is in the space between the two driving gears, it will not be turned. If it is a little to one side, it will be engaged by only the one longest tooth and will be rotated only one tooth for each revolution of the driving gear. As it is moved farther and farther toward the outside edge of the driving gear, the driven gear will be engaged by more and more teeth of the driving gear until, when it is at the extreme outer edge, it will be engaged by teeth all the way around and will be

engaging the same driving gears and controlled by a second Scotch Yoke gives motion which is proportional to the cosine of the angle of heading. Each of the two driven gears turns a splined shaft which is geared to one or the other of the two lead screws giving the two coordinates of motion to the mapping pencil, so that the motion of these two screws is proportional to the forward motion of the vehicle multiplied respectively by the sine and cosine of the angle of heading and, therefore, the condition for mapping is fulfilled.

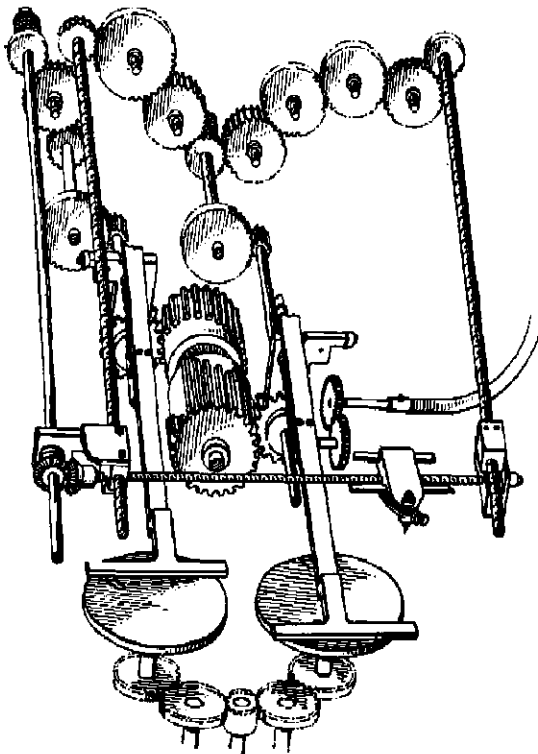

FIGURE 23. Schematic drawing showing operating principle of stepped-tooth gear integrator.

INTERPOLATION BY HUNTING

It is evident that the degree of coupling between the driving and driven gears varies by discrete steps, as the lateral motion of the driven gear picks up or drops one tooth of the driving gear. However, on account of the oscillation of the compass follower, the Scotch Yoke continually moves back and forth by a small amount. If its mean position is such that the driven gear is intermediate between the ends of two teeth on the driving gear, this motion back and forth is such that part of the time a given number of teeth is engaged, and part of the time one more tooth is engaged. This oscillation serves to accurately interpolate between the integral number of teeth of the driving gear, so that the average rotation of the driven gear is proportional to the whole number of teeth plus a fractional number to give the proper fraction so that the correct rotation of the driven gear results. The analysis of this interpolation and a theory of linear hunting have been worked out in considerable detail.^{16a}

rotated by a maximum amount. If the driven gear crosses the central space between the two and begins to be engaged by the oppositely rotating driving gear, it is evident that a similar coupling will take place, but with the driven gear rotating in the opposite direction. Thus the amount of rotation of the driven gear will be directly proportional to its position along the axis of the stepped driving gears, and the condition that its rotation is proportional to the sine of the angle of heading will be fulfilled, as the position is controlled by the sine disk slaved to the compass. The second driven gear

AUXILIARY INDICATIONS

As now developed, two other indications besides the map itself are shown on the visible face of the machine. One of these is a dial or azimuth indicator which repeats the reading of the compass and, therefore, gives a continual indication of the heading of the vehicle. This is desirable as the compass itself is usually in another part of the vehicle with its position dictated by considerations of magnetic environment, and is totally enclosed so that the position of its card is not visible.

The second auxiliary indication carried by

the integrator unit is a pair of counter dials which add up the two components of motion. These can be calibrated in miles or other units to give the total distance north or south and east or west of the starting point at which they are set at zero, or can be calibrated and set to give latitude and longitude. A third dial may be used to give the total distance traveled by the vehicle.

PROVISIONS FOR VARIABLE MAP SCALE

It is evident that the scale of the map produced, i.e., the ratio of the motion of the pencil

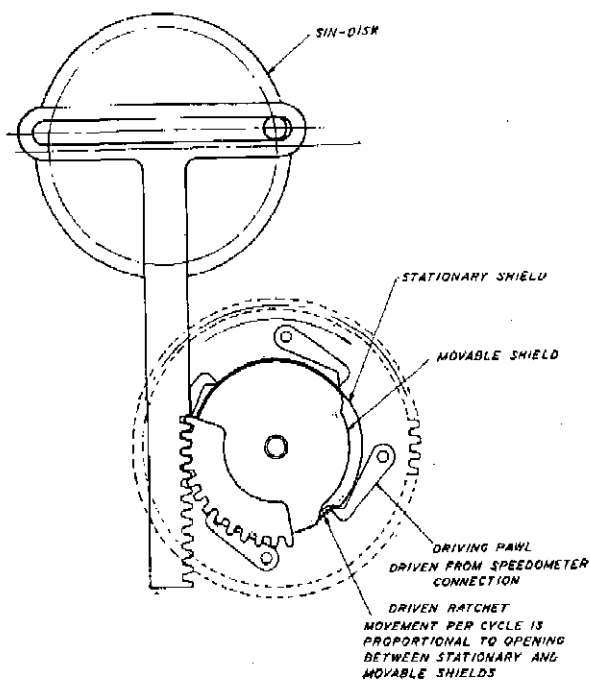

FIGURE 24. Schematic diagram showing principle of pawl-and-ratchet variable coupling.

on the map to the motion of the vehicle on the ground, will depend upon the various gear ratios of the odometer drive and of the coupling between the driven gears and the lead screws. For different applications of the odograph, it is desirable to make maps at different scales, which requires that the operator be able to change the scale ratio for different circumstances. For instance, if a map were desired of a short operation extending only a few miles from the starting point, it might be desirable to use a scale of, say, 1 to 24,000 (approximately $2\frac{1}{2}$ in. equal 1 mile), which would per-

mit mapping the proposed operation on a relatively open scale on the limited area of the odograph mapping table. For a more extended operation, a map covering a much larger area, and therefore with a greater scale ratio, would be desirable. To permit a variable scale ratio, a set of gears is provided so that the coupling ratio between the odometer drive and the integrator may be varied.

In the DTM model integrator, as engineered for manufacture, the ratio-changing gears are much like a miniature of the variable speed transmission of an automobile. By setting a dial controlling the positions of these gears, the odograph map will be drawn according to the selected one of a group of ratios corresponding to commonly used mapping scales. Moreover, an interpolating device is included which has a variable coupling (using stepped gears similar to those used for the integrator itself) by which a wide range of scale ratios may be interpolated between those of the primary scale ratio selector.

1.5.3 The IBM Ratchet Drive Integrator

This is an alternative integrator which was used on many land vehicle odograph installations and was made in some quantity. The device was developed and manufactured by the International Business Machines Corporation under a contract with OSRD. In the following paragraphs, the essential functions performed by this integrator will be described without going into all the mechanical details which, in the aggregate, involve an assembly of gears, ratchets, clutches, etc., with the individual parts being rather similar to those of calculating and other business machines.²⁷

THE RATCHET DRIVE VARIABLE COUPLING

The variable coupling for this integrator is attained through the use of ratchets and pawls, together with a set of rotatable shields so arranged that an opening between the shields permitting the engagement of the pawl on the ratchet is variable, and this opening is controlled by the position of a Scotch Yoke. The general principle of this arrangement is shown in Figure 24.

The driving wheel carrying four pawls is connected to the odometer element and rotates by an amount proportional to the travel of the vehicle. As this wheel rotates, the pawls engage the ratchet for that part of the rotation during which they are allowed to drop down into the gap between the stationary and movable shields. Thus the amount of motion which is transferred from the driving pawls to the driven ratchet is governed by the opening of the shields. It is evident that by making this opening directly proportional to the position of the

It is evident that the pawl-and-ratchet coupling between driving and driven members can give only a discrete number of changes in the ratio of coupling, for it is governed by the discrete number of ratchet teeth which are exposed by a variation from zero to maximum of the shield opening, corresponding to a rotation of 90 degrees of the sine disk. In this integrator, the number of teeth is twenty-nine, so that only twenty-nine coupling steps are available. However, the 10-degree hunting of the compass follower, which was mentioned in the section on

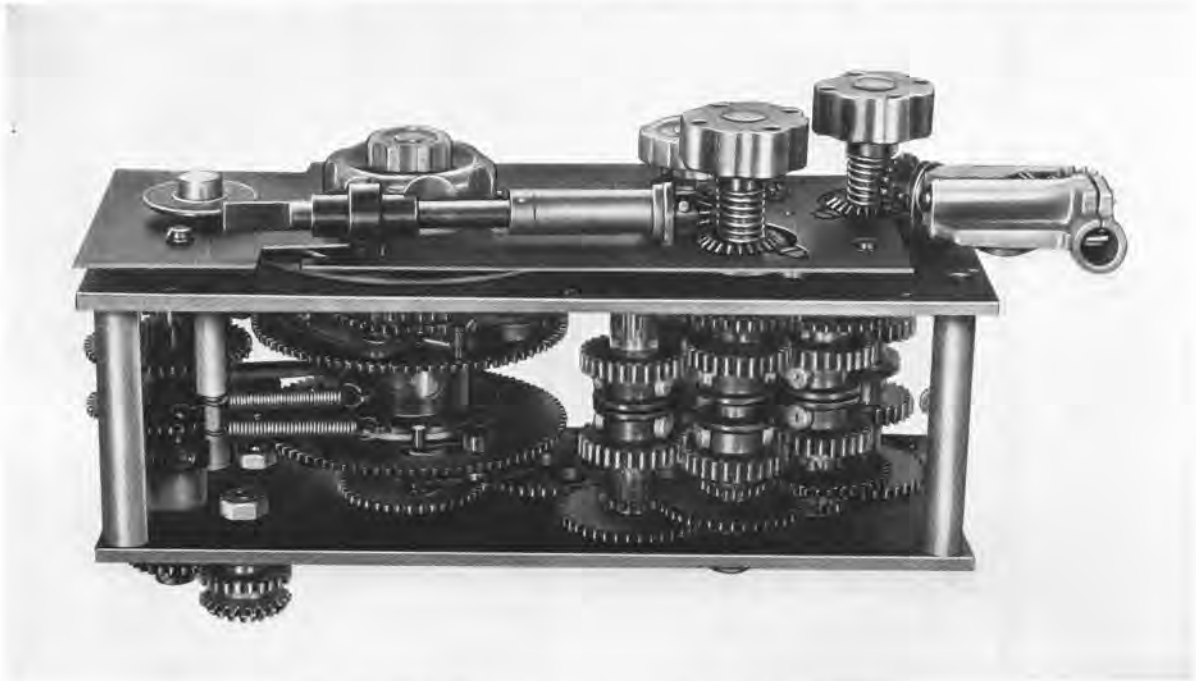

FIGURE 25. Map scale-changing unit, IBM integrator.

bar of a Scotch Yoke, as shown by Figure 24, the amount of motion transferred to the driven ratchet will be that of the wheel carrying the driving pawls multiplied by the sine (or cosine) of the angle of the sine disk. A set of block-out shields (not indicated in the figure) is used to transfer the driving effect of the pawls from one ratchet to another when the Scotch Yoke passes through its zero or middle position. The second ratchet is connected through reverse gearing so that the output drive is reversed, thus giving the required change of sign when the component of motion changes from north to south.

compasses, provides accurate interpolation between the discrete ratchet tooth intervals. As the compass follower swings back and forth through its 10-degree arc, the sine disk controlling the Scotch Yoke also swings through this same interval, resulting in a small oscillating motion of the bars controlling the openings of the ratchet shields. Thus, on one revolution of the driving wheel carrying the pawls, a pawl might engage, say, twenty-three teeth, and on the next revolution it might engage, say, twenty-two, so that, on the average, the motion of the driven ratchet would correspond to twenty-two and one-half teeth. It may be re-

peated here that the random relation between the oscillation of the sine disk and Scotch Yoke, which follows the swing of the compass follower, and the motion of the pawls works out in the same way as was mentioned in connection with the stepped gear integrator, and that the precision of the interpolation between the integral ratchet steps is entirely adequate for odograph applications.^{15d}

The above description has outlined the means by which ratchets are driven by amounts proportional to the motion of the vehicle multiplied by the sine (or cosine) of the azimuth of its motion with respect to a reference (north) direction. In the actual instrument, there are two sets of pawls on opposite sides of the main drive gear; one set of pawls and ratchets is controlled by a Scotch Yoke, the position of which is proportional to the sine of the azimuth angle, and the second set by a second Scotch Yoke, the position of which is proportional to the cosine of the azimuth angle. The driven elements of these two sets are connected through a scale-changing gear box to two lead screws. One of these moves a carriage in a north-south direction on the odograph map table. The second lead screw, transverse to the first, is carried on the carriage and moves the marking pencil in an east-west direction. Thus the combination of motion of the two screws serves to drive the pencil on the map by an amount which is proportional to the cardinal components of the motion of the vehicle, and thereby reproduces, to scale, the course over which the vehicle has moved.

SCALE CHANGING AND OTHER ACCESSORIES

This IBM integrator has a flexible map-scale ratio-changing device which provides not only for discrete changes in ratio to correspond with certain fixed or standard scales, but also provides for continuous variation of scale between the fixed values. This has been done so that an air photograph, for instance, with a nonstandard scale (determined by the height from which the picture was made) may be put on the odograph map table, and the odograph scale ratio may be adjusted so that the trace of the course followed will fit the air photograph. The discrete scale changes are given by a four-step, gear-shifting device, and the continuous varia-

tion is given by a ratchet-and-pawl arrangement similar to that of the primary integrator (Figure 25). This gear-and-ratchet assembly is interposed between the odometer drive and the integrator drive so that it permits changing the scale ratio by small steps over a wide range.

This integrator also contains an azimuth or heading indicator which repeats the compass bearing by means of a connection between the sine disk of the integrator and a pointer of the integrator table, which shows the bearing of the vehicle with respect to the reference direction.

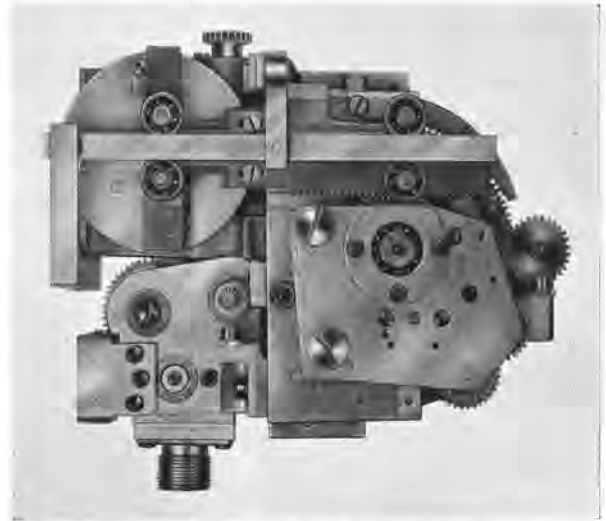

FIGURE 26. Integrator unit of IBM integrator, showing Scotch Yoke, part of main driving gear, and lock-out shield.

Furthermore, provision is made through differential gears for correction of magnetic deviation so that the indicator continually points to the bearing of the vehicle with respect to true north, rather than magnetic north.

This integrator also contains a counter unit which provides numerical indications of the total miles traveled, and also of the north-south and east-west components of the mileage. Photographs of the complete instrument are shown in Figures 26, 27, and 28.

It should be pointed out that the complexity, size, and weight of this and the other integrators described are very materially increased by the various auxiliary parts, including the azimuth indicator and counters and, particularly, by the scale-changing unit. A simple odograph

or map-maker at one scale could be a much simpler, smaller, and lighter device.

1.5.4 The IBM Disk Drive Airborne Integrator

The description that follows is based primarily on the Model AO-3 airborne odograph as developed by International Business Machines

receiving autosyn of the odograph integrator, there is induced a single-phase output voltage, the magnitude and sign of which depend upon the rotor position. This voltage passes through zero, and the phase reverses when the rotor passes through the position which corresponds with that of the rotor in the transmitting autosyn of the master indicator of the compass. The output of the rotor of the autosyn in the integrator controls the grids of two thyatron tubes which, in turn,

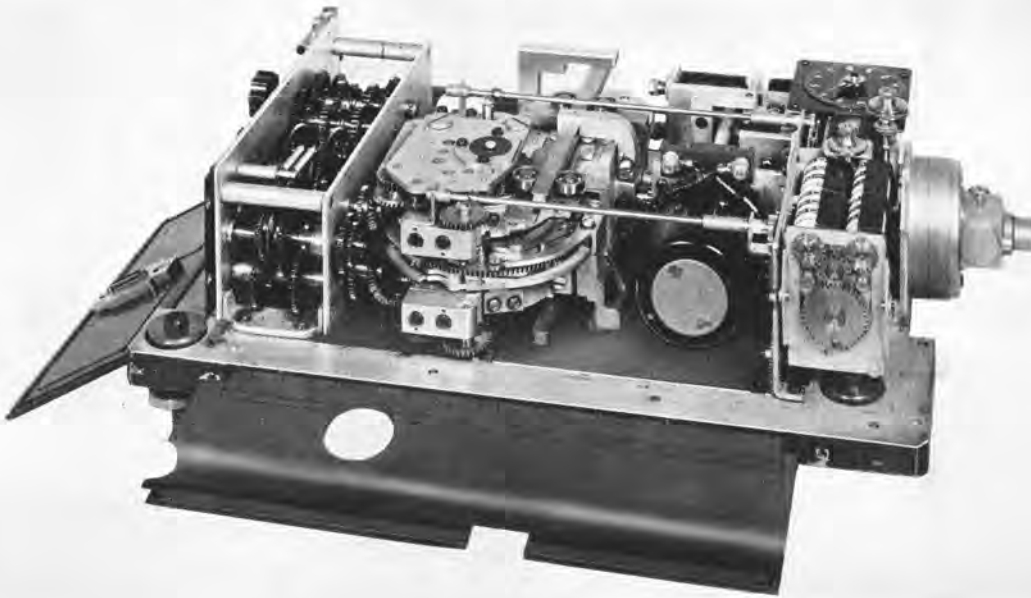

FIGURE 27. General view of IBM integrator with case open.

Corporation.²⁶ The reference direction is derived from the Pioneer fluxgate compass system, and the distance is taken from a British or Pioneer air mileage unit.

GENERAL DESCRIPTION — AIR POSITION COMPONENTS

A constant-speed motor, 1 (see Figure 29), is connected by gears and a clutch mechanism and through a differential, 2, to a worm gear which drives the rotor of the autosyn, 3, within the integrator. The orientation of the three-phase field in the autosyn is controlled by the transmitting autosyn in the master indicator of the fluxgate compass. Within the rotor of the

control the clutches, 4, which operate the gearing by which the motor turns the autosyn rotor. The phase of the control grid voltage of the thyatron tubes with respect to that of the plate voltage is such that only one tube and one clutch can be active at the same time, and the relations between the clutches and the gearing are such that the autosyn rotor is turned in the direction towards that in which the rotor output is zero. This serves to keep its orientation the same as that of the rotor of the transmitting autosyn in the master indicator. The action of the thyatron tubes and the clutches is such that the rotor tends to overshoot the zero position, whereby the direction of rotation is immedi-

ately reversed so that the rotor hunts about the zero position. The rate of hunt is controlled manually by an external knob (located on the course control amplifier) which controls the bias voltage on one of the grids of the clutch control tubes.

It was mentioned that the connection to the autosyn rotor is through the differential, 2. The other side of this differential is connected

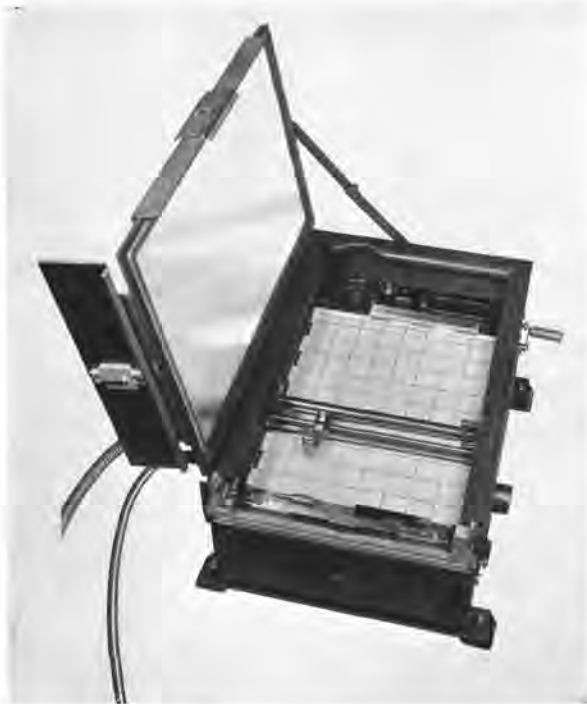

FIGURE 28. General view of integrator plotting table, showing transverse lead screw, direction indication, and distance dials.

through a gear to a control knob, 5, on the front of the integrator. Rotation of the differential gear by this knob changes the angular relation between the clutch control gears and the autosyn rotor, thus providing means by which the magnetic variation (deviation from true north) may be set off. Then the autosyn rotor is balanced at a point corresponding to the magnetic north while the gearing connected to the clutches hunts about a position corresponding to the astronomic north.

The gearing controlled by the compass drives azimuth gears 6E and 6N. Pins, 7, in these gears operate in long vertical slots in the slide

assemblies, 8, moving these slides horizontally to positions corresponding to the sine and cosine, respectively, of the angle of heading, thus acting as Scotch Yokes. The slide assemblies control the position of small pickup rollers, 9N, 9E, which are moved along horizontal diameters over the two Neoprene-covered faces of the rotating disk. Thus the speed of rotation of these rollers is proportional to their distance out from the center of the disk. The rotating disk is supported and driven from its periphery so that both faces are free and one roller, controlled by one slide assembly, rides on one face, and the second roller, controlled by the second slide assembly, the pin of which is 90 degrees out of phase with that of the first, rides on the other face. The disk is driven by gear 11, which is connected by a flexible shaft to the motor of an air mileage unit, 12, so that the rate of rotation of the disk is directly proportional to the speed of the plane through the air. Since the azimuth gears and slide assemblies are continually controlled by the gearing and clutches which follow the autosyn rotor, the horizontal positions of the two pickup rollers are maintained proportional to the sine and cosine of the azimuth or heading of the ship. Since the speed of rotation of the disk is proportional to the speed of the ship, the shafts, 13N and 13E, turned by the rollers rotate at speeds proportional to $V_a \sin \alpha$ and $V_a \cos \alpha$, respectively (where V_a equals airspeed and α equals angle of heading).

The shafts, 13N, 13E, operate pairs of counters, 14N, 14E, which give numerically the north or south distance in air miles and the east or west distance in air miles. These shafts also are connected to one side of differentials, 15N, 15E, the input to the other side of which comes from the air drift compensator to be described below.

THE WIND CORRECTION COMPONENTS

In order to give the position of the plane relative to the ground, it is necessary to make a correction for the magnitude and direction of the drift with the wind. Since all the elements described above are referred to the air, they give the position of the plane relative to the air.

The correction for drift is made by another integrating unit similar to that just described

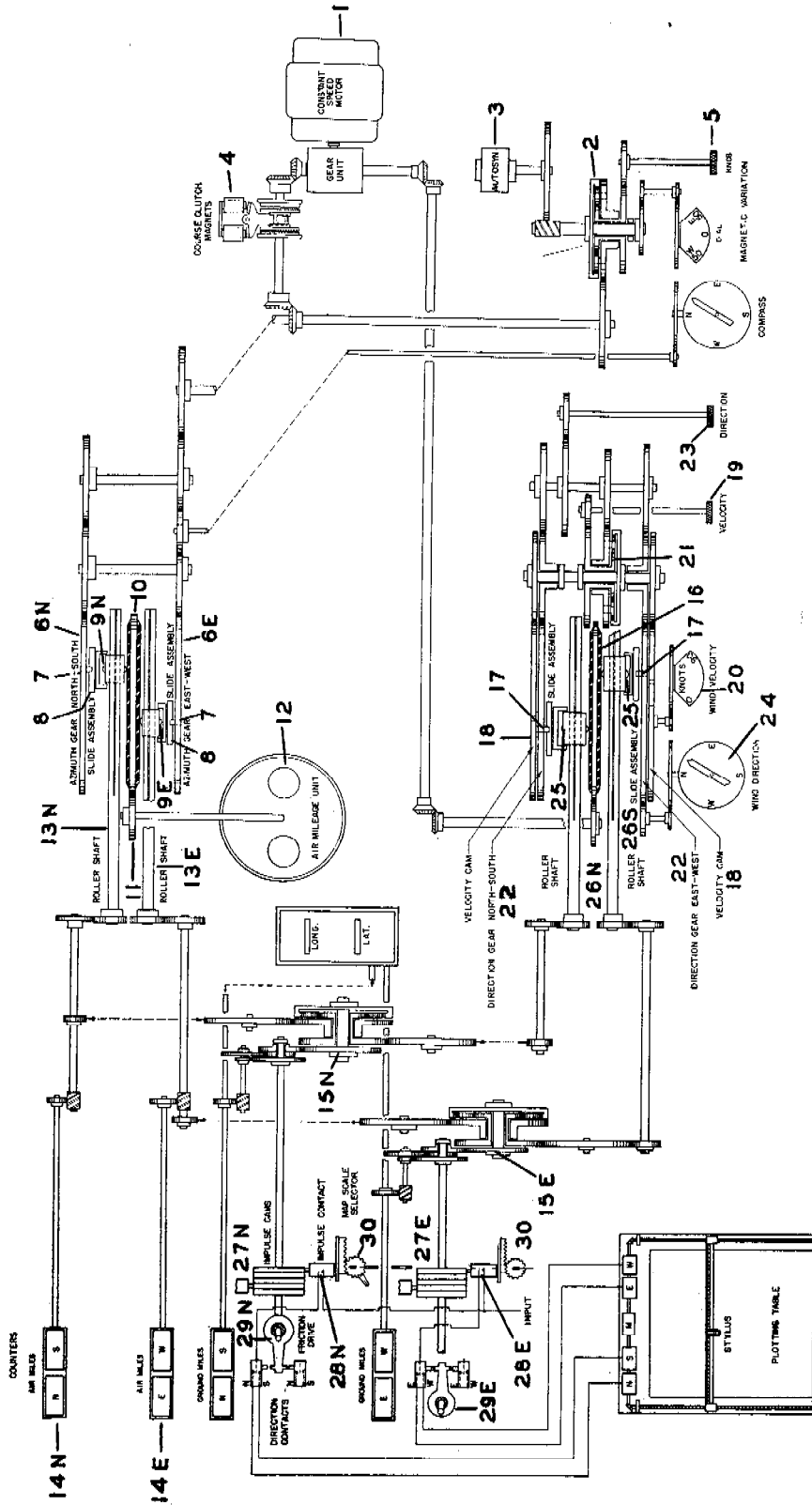

FIGURE 29. Schematic drawing of disk-drive integrator with wind correction for airborne odograph.

except that: (1) the rate of rotation of the second integrator disk, 16, is constant as it is geared back to the constant speed motor, 1; and (2) the radius of pins, 17, in the slide assembly slots, is variable and is controlled by velocity cams, 18. When the velocity knob, 19, is turned so that the wind velocity indicator, 20, is set on a scale at a position corresponding to the actual wind, the relative positions of the velocity and

associated pickup rollers, 25, 25, are set so that the two shafts, 26N, 26E, driven by the rollers on the two sides of the disk, are turned at rates proportional to $V_w \sin \beta$ and $V_w \cos \beta$ (where V_w equals wind velocity, and β equals wind direction).

These shafts are connected to the second input side of the output differentials, 15N, 15S (to which the other input side is connected, as

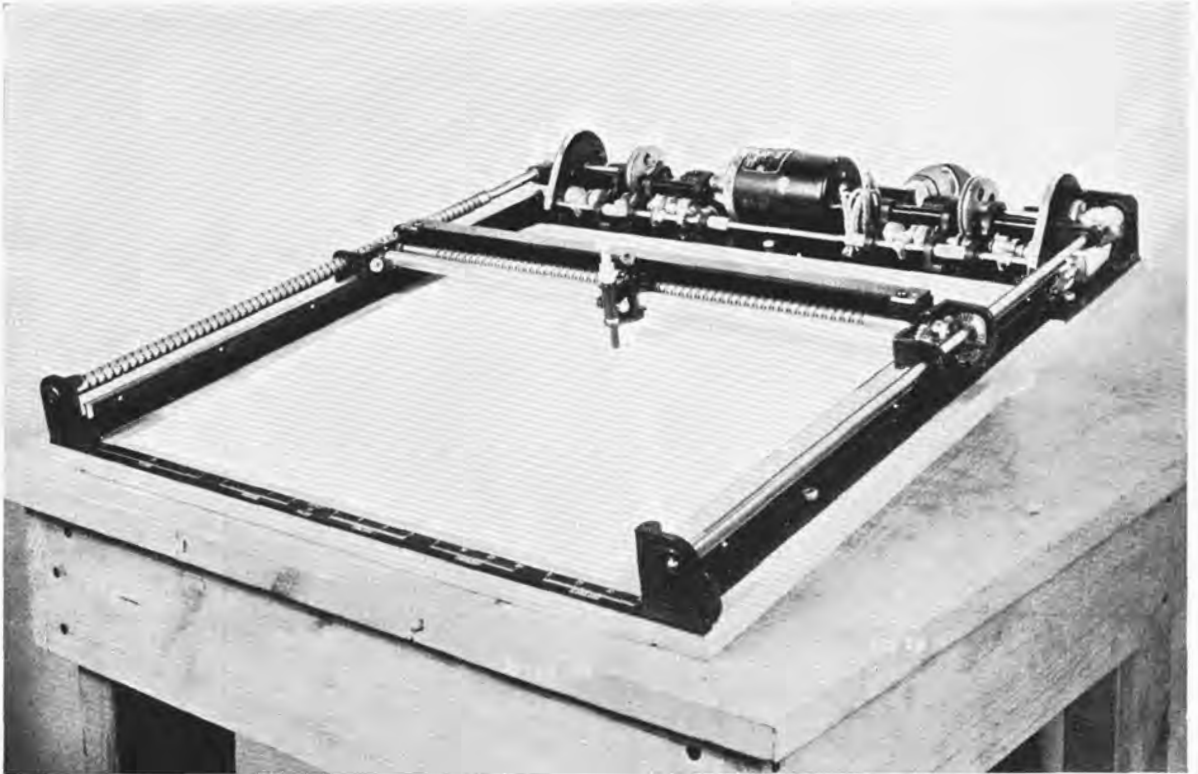

FIGURE 30. Plotting table of airborne odograph showing double threaded lead screws and drive mechanism.

direction cams are adjusted through the differential, 21, and are such that the pins, 17, are both on a radius out from the center of the disk corresponding to the wind velocity. The direction gears, 22, and velocity cams may be rotated together by knob, 23 (through the differential, 21), which sets the pins corresponding to the sine and cosine of the wind direction, as shown by the indicator, 24. Then the horizontal positions of the N-S and E-W slide assemblies and

previously described, to the output gears of the air position integrator disks). The differentials serve to combine the two inputs so that the outputs of the two differentials which drive the two sets of impulse cams, 27N and 27E, are $V_a \sin \alpha - V_w \sin \beta$ and $V_a \cos \alpha - V_w \cos \beta$, respectively. Thus, if correct values of V_w and β have been set into the wind correction integrator, the wind drift is taken out, and the motion of the impulse cams is proportional to

the cardinal components of the motion of the plane with respect to the ground.

THE PLOTTING TABLE

The impulse cams operate electric contacts, 28N, 28E, which control clutches, N, S, E, W, on the plotting table. These clutches control gears driven by a motor on the plotting table (Figure 30), so that, for each contact of the



FIGURE 31. General view of airborne integrator and plotting table.

impulse cams, the corresponding N-S or E-W screw on the plotting table is turned by one-tenth of a revolution.

Friction-driven switches, 29N, 29E, change the electric connections each time the direction of the impulse camshaft reverses, so that the impulse is properly transferred to the other of the pair of N-S or E-W clutches, and the direction of rotation of the corresponding screw on the plotting table reverses whenever the direction of motion of the impulse cams is reversed.

The number of teeth on the impulse cams determines the number of contacts per revolution and thereby determines the rate at which the plotting table screws are operated and thus

the scale at which the stylus traces on the plotting table. Different map scales are made very simply by providing impulse cams with different numbers of teeth, and the map scale selector, 30, operates to set the contact to ride on the impulse cam having the corresponding number of teeth. A second plotting table can be operated by a second pair of contacts operated by the same impulse cams. Furthermore, it is not necessary that the two or more contacts be operated by the same cam, so that it is possible to provide two or more plotting tables operated at different scales, if desired. In the instrument as built, the scale ratios are in five steps, from 1 to 40,000 to 1 to 2,000,000.

The screws on the plotting table are double threaded (see Figure 30), and the nut following the screws is arranged so that, when it comes to the end of travel of either screw, it shifts to the other thread and reverses the direction of that component of the motion of the stylus. This keeps the stylus from running off the edge of the table (if the course of the ship would take it beyond the limits corresponding to the area of the plotting table) by reversing it back onto the table in a mirror image of the course which it would have if the table were not limited. This permits reconstruction of those parts of the course which otherwise would not be mapped, as they would be beyond the limits of the plotting table.

The stylus on the plotting table is provided with a position marker. When depressed, either manually or, if desired, electrically by a push-button control, the marker makes a small colored inked circle about the point of the marking stylus. This provides a simple means by which the instantaneous position of the ship may be marked at any time on the map. This is particularly desirable in applications where it may be necessary to return to a given point or where reference to a given spot on the ground may be desired.

DATA FOR WIND DRIFT CORRECTIONS

The odograph itself provides a means of determining the wind drift for making the wind correction. If the plotting table is operated with the wind correction at zero, the map will give the air position rather than the ground position

of the ship. If, at the time the ship is over a certain point on the ground, a mark is made showing the corresponding position on the odograph map and then the ship flies in a loop and comes back over the same point on the ground and another mark is made on the odograph map, the vector connecting these two marks is a direct

rection controls set accordingly. (See Figure 48.) Wind correction may be set also directly from meteorological observations signaled to the plane.

PICTURES AND DIMENSIONS OF COMPLETE UNITS

A general view of the complete integrator

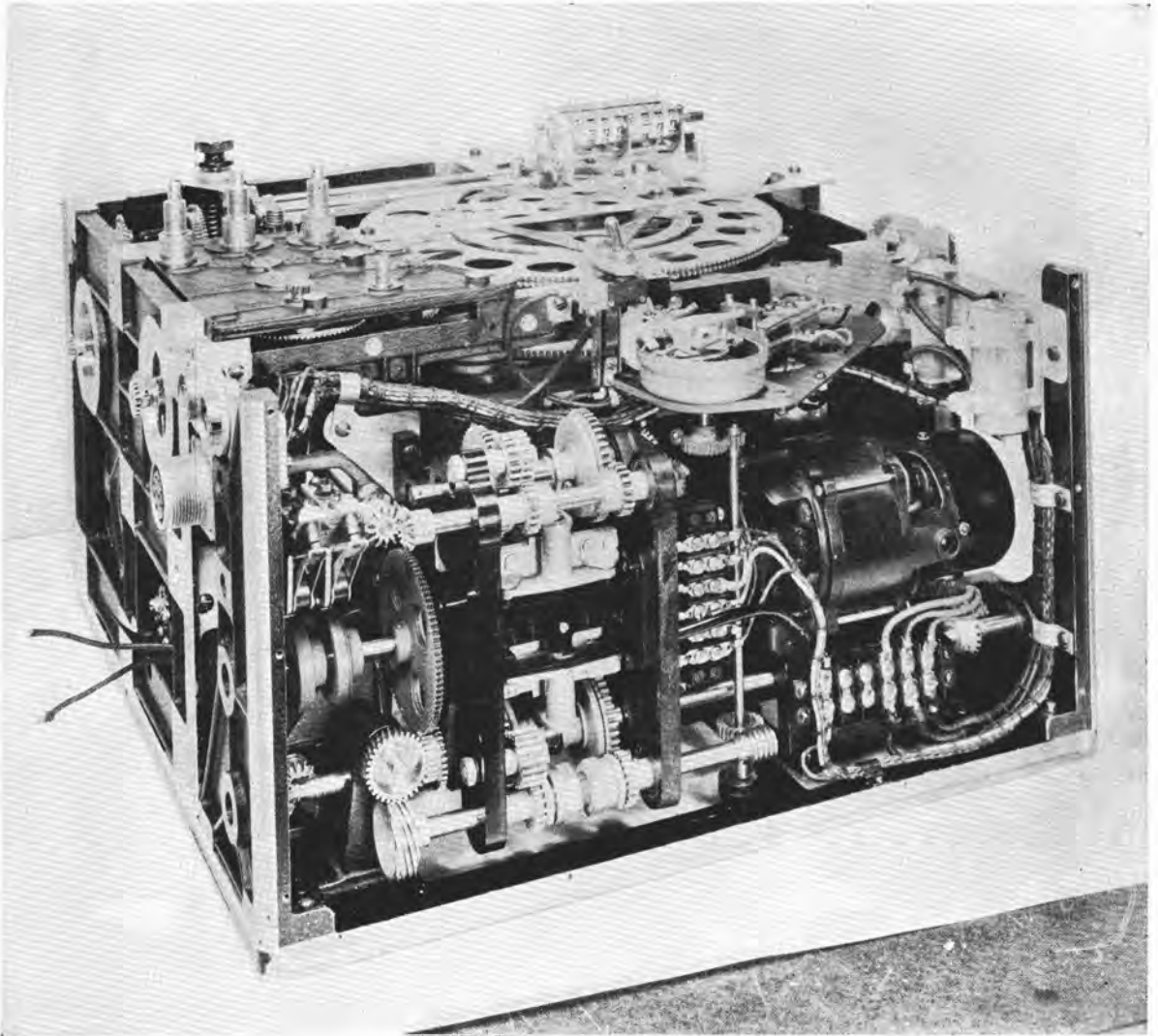

FIGURE 32. Interior of airborne integrator.

measure of the speed and direction of the wind. By measuring the azimuth and length of this vector and taking proper account of time interval and scale setting, the direction and speed of the wind can be determined and the wind cor-

and plotting table is given in Figure 31. An interior view is shown in Figure 32, while Figure 33 shows the main integrating disk, wind correction disk, and slide assemblies.

The dimensions and weights of the various

units making up the complete installation of the airborne odograph, Type AO-3, and its accessories are as follows:

Integrator (14 $\frac{1}{4}$ x14 $\frac{1}{4}$ x10 $\frac{3}{16}$ in.)	55 lb
Plotting table (9 $\frac{1}{16}$ x21 $\frac{1}{16}$ x3 $\frac{1}{2}$ in.)	15 $\frac{1}{2}$ lb
Course control amplifier (6 $\frac{1}{2}$ x9 $\frac{5}{8}$ x7 $\frac{1}{16}$ in.)	5 $\frac{1}{2}$ lb
British air mileage unit	16 $\frac{1}{2}$ lb
Fluxgate compass and gyro	7 lb
Gyro caging motor	2 lb
Master indicator	6 $\frac{1}{4}$ lb
Amplifier for compass unit	11 lb

Total 118 $\frac{3}{4}$ lb

(Weights are exclusive of connecting cables.)

1.6 REPORTS ON TEST INSTALLATIONS

The general comments of this section are based on the various reports which describe spe-

cial test installations, and the pictures and odograph maps are from those reports. Many other test runs, not covered specifically by reports, were made at various times throughout the development. The test installations covered by the reports were, in most cases, in relatively early stages of particular phases of the development, and the maps made suffer from the usual difficulties of early experimental trials. No attempt has been made to include results of routine uses of the equipment in military operations, as records of these are not included in the material on which this report is based.

The test installations mentioned are listed in the following table, which includes all tests covered by regular reports but no others.

Test Installations

Reference	Vehicle	Date	Compass	Mileage unit	Integrator
<i>Vehicular Odograph</i>					
2	British jeep	Dec. 1942	DTM (Monroe)	Speedometer cable	IBM (ratchet drive)
19	4x4 $\frac{1}{4}$ -ton jeep	Oct. 1943	GM Ind. and Monroe	Speedometer cable	IBM
21					
1b	Light tank	July-Aug. 1942	DTM	Speedometer cable	Monroe (stepped gear)
1c	Med. tank	June 1942	DTM	Speedometer cable	Monroe
1f		Jan. 1943	DTM	Speedometer cable	Monroe
22	M3A1 light tank	July 1944	GM Ind. outside armor	Speedometer cable	Monroe
3	Half-track	Jan.-Mar. 1943	DTM	Speedometer cable	Monroe
5	M-29 Army motor sled	Nov.-Dec. 1943	Monroe	Trailed wheel	Monroe (marine type)
4	T-15 snow tractor (Weasel)	Jan.-Mar. 1943	DTM	Speedometer cable	IBM Model B (ratchet drive)
6	DUKW (amphibious truck)	Dec. 1942	Monroe	Speedometer and impeller	IBM (disk drive)
		Mar. 1943
		Mar. 1944	Monroe	Monroc log pickup	IBM (ratchet drive)
<i>Airborne Odograph</i>					
1d	B-18	Oct. 23 1942	Fluxgate	Schwieb	IBM
1e	Army bomber	Oct. 9 1942			(disk drive)
1h	B-24	Feb. 1943	Fluxgate	Schwieb	IBM
	Army bomber				
9	RA-29	Apr. 1943	Fluxgate	Pioneer AMU	IBM
7	OA10				
	Army patrol flying boat	Nov. 1943 Jan. 1944	Fluxgate	British AMU	IBM
8	PBM				
	Navy patrol flying boat	Dec. 1943 Jan. 1944	Fluxgate	British AMU	IBM

1.6.1

British Jeep²

This test installation was made as a demonstration of the odograph when it was taken to England in the winter of 1942-1943. The installation was made in England on a British jeep

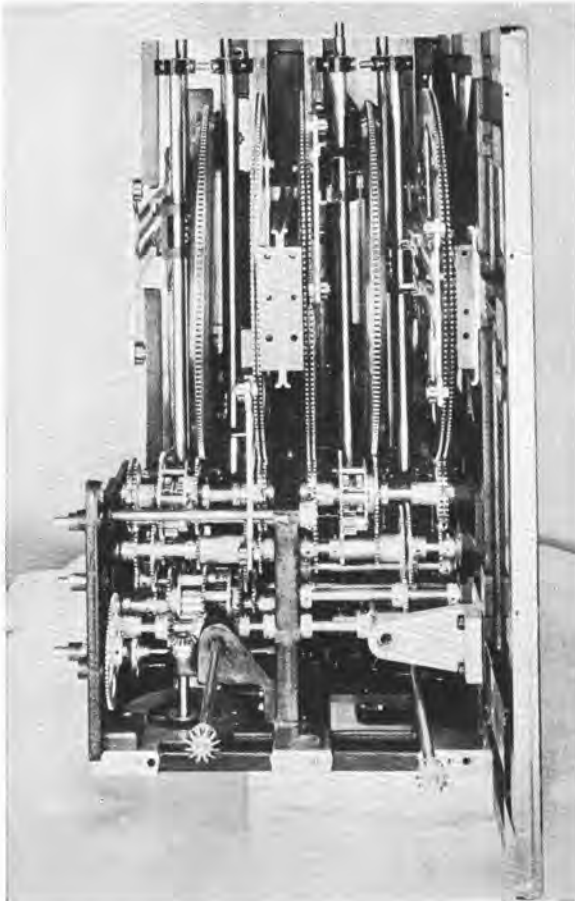

FIGURE 33. Interior view of airborne integrator, showing integrating disk and wind correction disk.

(of American manufacture), and the installation was, in general, similar to those made on similar vehicles in the United States.

The purpose of these tests was to demonstrate the operation of the equipment to interested British Army officers, a number of whom observed the operation while making small maps; some larger maps were made. In general, the operation was considered satisfactory with closures on trips of from 10 miles to 200 miles generally between 1 and 2½ per cent.

No maps or figures of these tests are reproduced.

1.6.2

**¼-Ton, 4x4 Truck (Jeep)
Comparative Tests of Inductor and
Standard Compasses^{20, 22}**

Two sets of comparative tests of different types of compasses were made to show the relative performance of the IBM inductor compass, the standard M-1 compass, and the DTM improved compass. The first tests (October 1943) were made with an earlier model of the inductor compass, installed in a jeep and connected with the production model IBM plotting



FIGURE 34. Installation of inductor compass on jeep, showing iron cylinders for quadrantal compensation.

unit. The second series of tests (April 1944) was made with the modified inductor compass (modified to fit into the standard M-1 compass case).

In both installations, magnets for semicircular and heeling compensation were mounted within the compass assembly, and two iron cylinders, one on each side of the compass, were

used for quadrantal compensation. (See Figure 34.)

The tests consisted of a series of runs at various speeds over a rough course. The purpose of varying the speed was primarily to subject the installations to various degrees of shock and vibration. The original reports contain many odograph maps made at various speeds by the different installations over the same courses. Examples of these maps have been included as Figures 13, 14, and 15 in Section 1.3.6.

These tests showed that both the inductor compass and the DTM improved compass were far superior in performance to the standard M-1 compass at medium and high speeds, for which the equipment was exposed to severe shock and vibration.

1.6.3

Light Tank^{1b}

This installation used a DTM compass and a Monroe integrator. The compass was mounted within the armor of the tank. The tests were conducted to determine the difficulties which would have to be met for tank installation. The principal difficulties encountered were disturbances to compass compensation caused by changes in the magnetic condition of the vehicle, by the change of position of certain movable equipment within the tank, and by electric currents. The disturbances were materially reduced by replacing an iron gear shift lever by one of brass and by rearranging some of the heavy current-carrying electric circuits to eliminate grounded returns, and thereby reducing the area of the circuits and correspondingly their magnetic fields and effects on the compass.

The tests included some 1,300 miles of mapping over roads of all sorts, from winding dirt roads to paved highways. Some of the maps were seriously in error due to compass disturbances, but many quite satisfactory maps were obtained when a number of minor mechanical and electrical faults in the installation had been corrected. One of the better maps from this series of tests is shown as Figure 35.

These tests served to point out a number of weaknesses of the equipment, none of which were fundamental, and to indicate the nature of the problems and the special arrangements of

equipment and certain minor modifications of parts of the tank (particularly electric circuits and certain moving iron parts) which would be necessary. The overall result seems to indicate that, with care in installation and frequent attention to compass compensation, reasonably satisfactory compass and odograph operation could be expected in a tank.

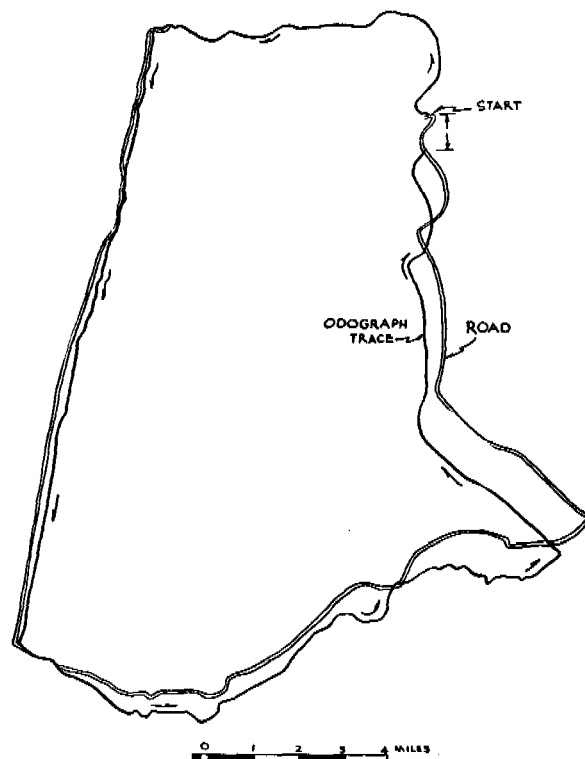

FIGURE 35. Trace of map made in light tank with compass inside armor. Double line: actual route; solid line: trace made by odograph.

1.6.4

Medium Tank (M4A1E2)^{1c, 1f}

A test installation in a medium tank turned out to be more complicated and difficult than those in any of the other Army vehicles. The difficulties arise because of the serious disturbances to the magnetic compasses due to: (1) the heavy steel armor which changes its magnetization and also shields the compass to a large extent and thereby reduces the strength of the controlling magnetic field; (2) electric currents from various circuits in the tank which produce magnetic fields at the compass and which become relatively more important

because of the reduction in strength of the directing field because of the shielding; (3) vibrations and shock which produce strictly mechanical deviations of the compass and which,

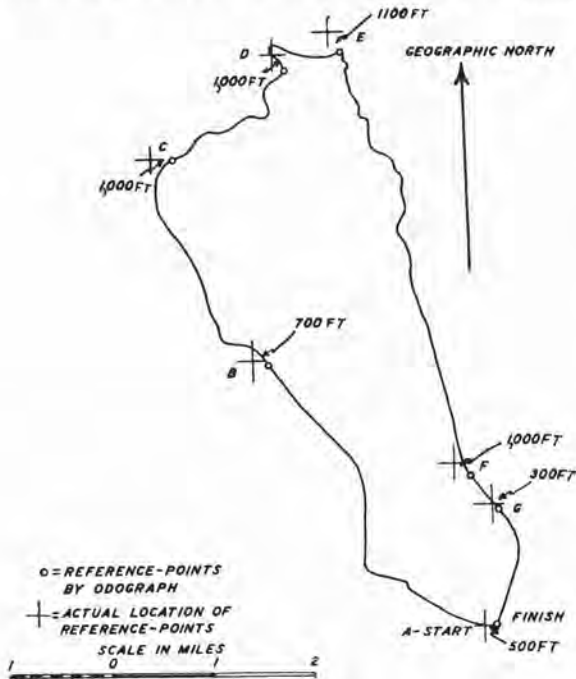

FIGURE 36. Trace of map made in medium tank, with compass inside armor, showing differences between actual and mapped positions at various points along route.

again, are aggravated by the reduced directive force because of the shielding.

A number of test maps and navigational problems were conducted with this installation, some of which showed quite good results, as, for example, Figure 36.

These tests indicated that with careful attention to compensation, sufficient accuracy is obtainable to warrant use of the odograph in this type of vehicle and that performance with errors of the order of 2 per cent on road mapping and 4 per cent on cross-country mapping could be obtained if the compass were compensated daily.

1.6.5 Light Tank—Compass Outside Armor²³

A series of test installations was made with the inductor compass mounted outside the

armor of a light tank. Separate tests were made with the compass mounted 6 in., 10 in., and 25 in. above the armor. The testing included a series of maps made with the M-1 land odograph and checks of shifts of compensation with the compass in each of the three positions. (See Figure 37.) It was found that the shifts in



FIGURE 37. M3A1 light tank, showing position of compass on outside of armor.

compensation were quite large with the compass only 6 in. above the armor and that the position 10 in. above the armor gave results almost as good as those obtained at 25 in.

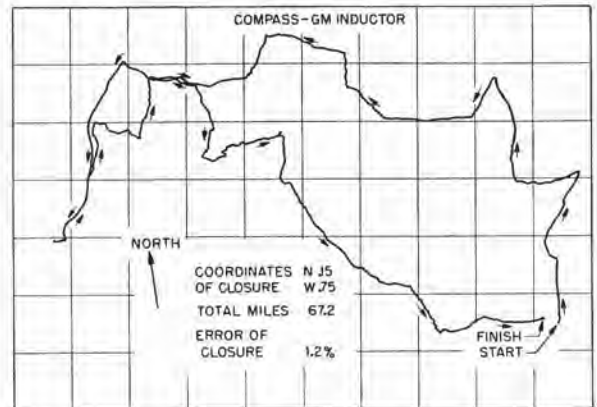

FIGURE 38. Map made in light tank with inductor compass mounted 10 in. above tank armor.

above the armor. In the 10-in. and 25-in. posi-

tions, fairly satisfactory maps were obtained (Figure 38), although the compensation shifts with time and mileage amounted to 2 degrees to 4 degrees for a long run, with these shifts disappearing to a certain extent after the tank stands overnight. In the 10-in. and 25-in. posi-

1.6.7 **Motor Sled and Other Snow Vehicles^{4,5}**

These tests were carried out to determine the applicability of the odograph to snow tractors and motor sleds. Two types of installations



FIGURE 39.



FIGURE 40.

Map made in half-track personnel carrier.

tions, the compass compensation was not materially affected by opening the doors on the front of the tank or on the gun turret, or by rotating the gun turret by 90 degrees from its normal position.

These tests indicated that quite satisfactory odograph performance may be obtained in tanks with the compass mounted outside the armor.

1.6.6 **Half-Track³**

This installation used a DTM compass and Monroe integrator. Some of the maps resulting from this test were rather poor because of incomplete compensation and difficulties resulting from change of the magnetic state of the vehicle. However, several maps with good closure were obtained, as are illustrated by Figures 39 and 40.

The general conclusions of this test were that the half-track personnel carrier is a suitable vehicle in which to mount the odograph, and that the magnetic compass should hold compensation for a period of from three to six days or from 100 to 400 miles of mapping.

were made, i.e., (1) on the tractor itself, and (2) on a cargo-carrying sled. The installations used the standard Monroe compass and the Monroe integrator, either driven by a speedometer cable (when installed on the vehicle itself) or by a Monroe log pickup unit (as used



FIGURE 41. T-26 snow tractor with trailer (on wheels) equipped with odograph. (Note odometer wheel behind trailer.)

in the marine-type installations) when driven by impulses from an odometer wheel attached to the cargo-carrying sled. The special trailer with odometer wheel is shown by Figure 41. In this installation, the integrator was mounted in the operator's seat of the T-26 snow tractor with electrical connection to the odometer wheel

through a log pickup unit which feeds one rotation of the drive shaft into the odograph by means of a clutch onto the electric motor each time an impulse is received from a contact

able in accuracy with those obtained on other vehicular installations. Maps made by installations in snow vehicles are shown as Figures 44 and 45.



FIGURE 42. M-29 cargo carrier, equipped with odograph as used in winter tests at Camp Echo Lake, Colorado.



FIGURE 43. General arrangement of equipment on M-29 cargo carrier.

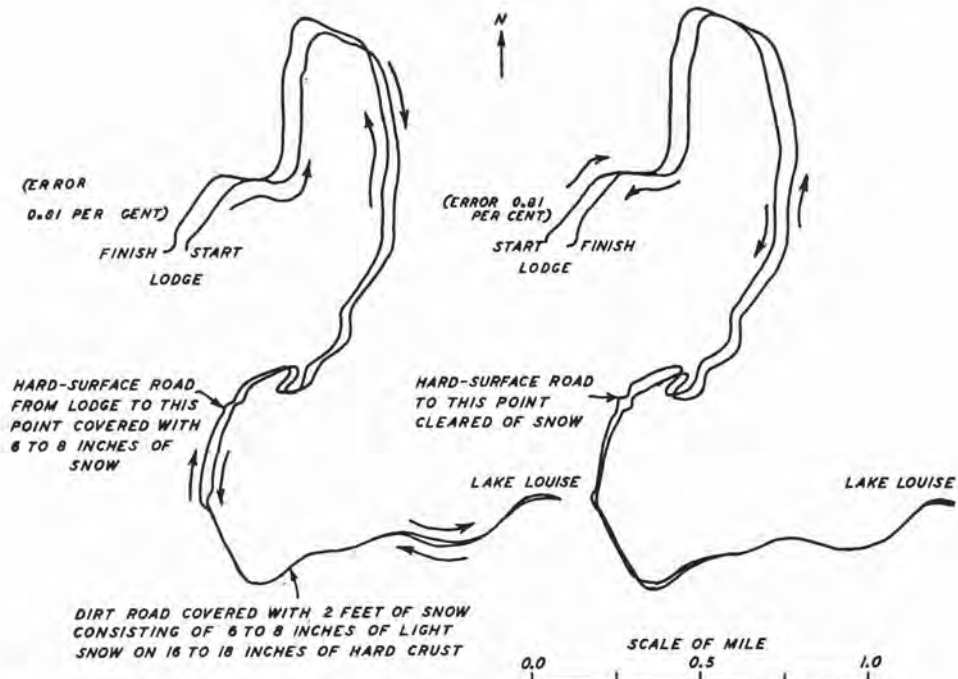

FIGURE 44. Maps made with odograph in special trailer, Mt. Rainier National Park.

mechanism operated by the odometer wheel.

The general arrangement on the M-29 cargo-carrying tractor is shown by Figures 42 and 43.

The general results of these tests were quite satisfactory and the maps made were compar-

1.6.8

2½-Ton Amphibious Truck (DUKW)⁶

The amphibious installation requires an indication of distance traveled from operation

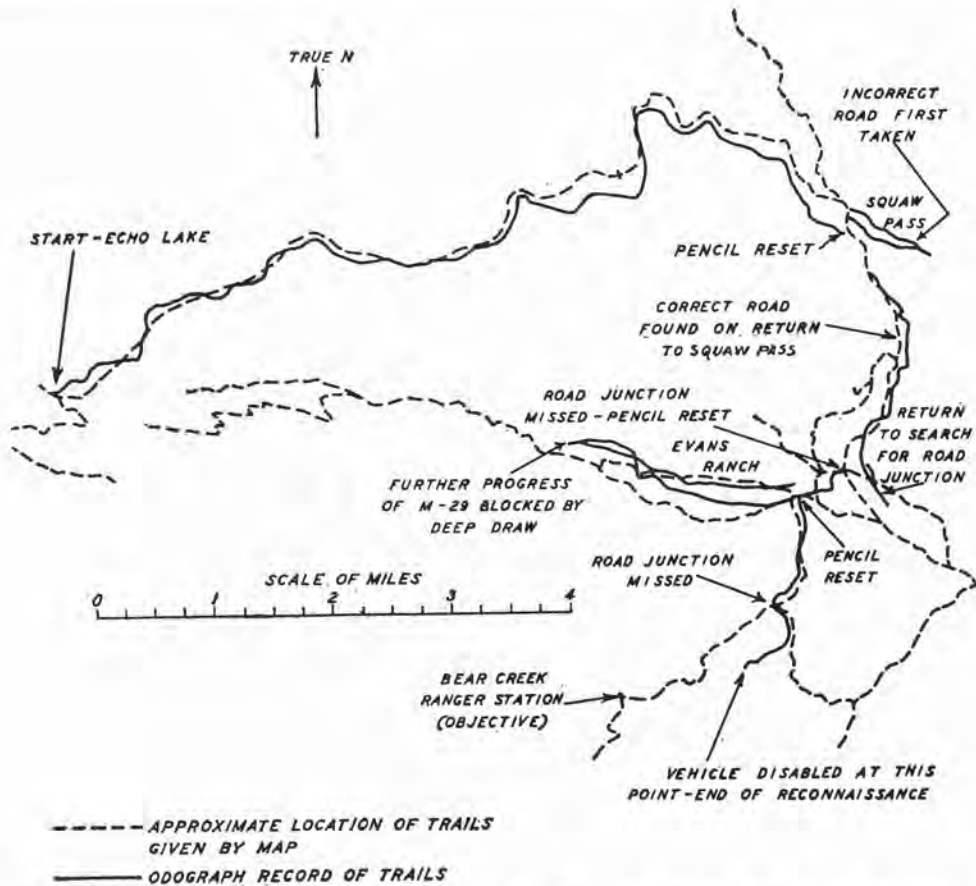

FIGURE 45. Trail reconnaissance with odograph in M-29 tractor, Camp Echo Lake, Colorado. Dashed lines: trails on map; solid line: route as mapped by odograph.

either on land or in the water. This was done by providing a log pickup unit (Stavrovkov) for providing distance traveled in the water and a speedometer cable (operating electric contacts instead of directly into the integrator) for providing distance traveled on land. Electric impulses from either the water log or speedometer cable operate a standard model log pickup unit, as built for the marine application of the odograph, and it is only necessary to operate an electric switch to shift from the speedometer pickup for land operations to the log pickup for water operation. The installation used a standard Monroe compass and the IBM vehicular (ratchet drive) odograph, and was mounted as shown by Figure 46.

No provision is made in these installations for any correction for drift of the boat with the



FIGURE 46. Odograph installation on amphibious truck (DUKW). Impeller in board (just forward of partition) for travel on land. Left, compass; center, plotting unit; right, log pickup unit.

~~CONFIDENTIAL~~

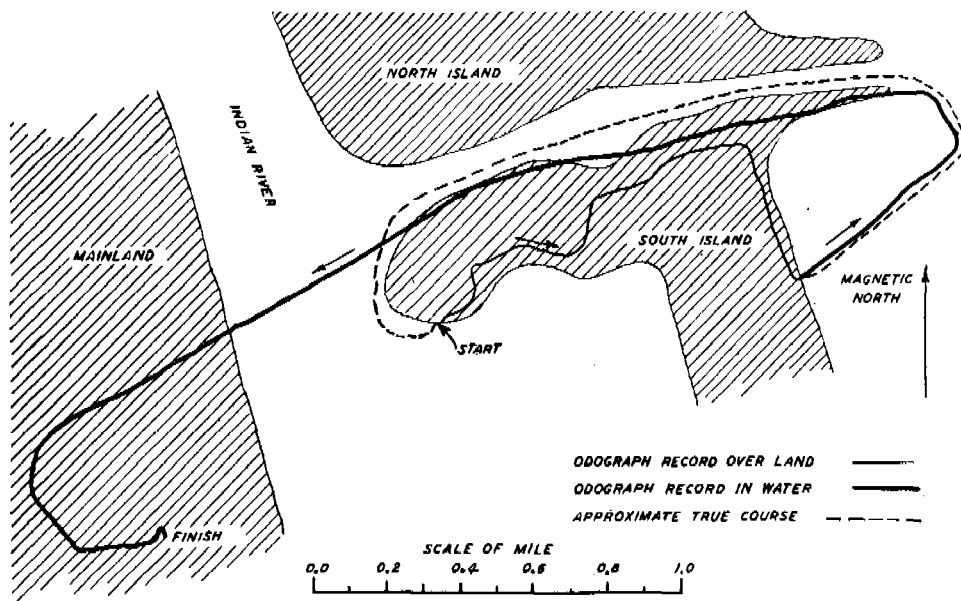

FIGURE 47. Odograph record made in DUKW, partly on land, partly in water. Large error is due to drift caused by current in water.

water. Therefore, the maps made (as shown by Figure 47) show large errors of closure on account of currents in the water.

These tests indicated that, on account of the slow speed in the water and the consequent relatively large disturbances caused by tidal and other currents, an odograph is not likely to prove particularly useful in amphibious vehicles of this type.

1.6.9 B-18 Army Bomber^{1d, 1e}

This test installation used a Pioneer fluxgate compass, a Schvien true airspeed meter, and an early model of the IBM disk drive integrator. Test flights were made in September and October 1942.

The integrator had no provision for compensation for air drift but such drift could be determined and the maps corrected accordingly by successive flights over the same point (Figure 48), or by calculating corrections from wind direction and velocity, as estimated from drift sights (Figure 49).

These were the first tests of the airborne odo-

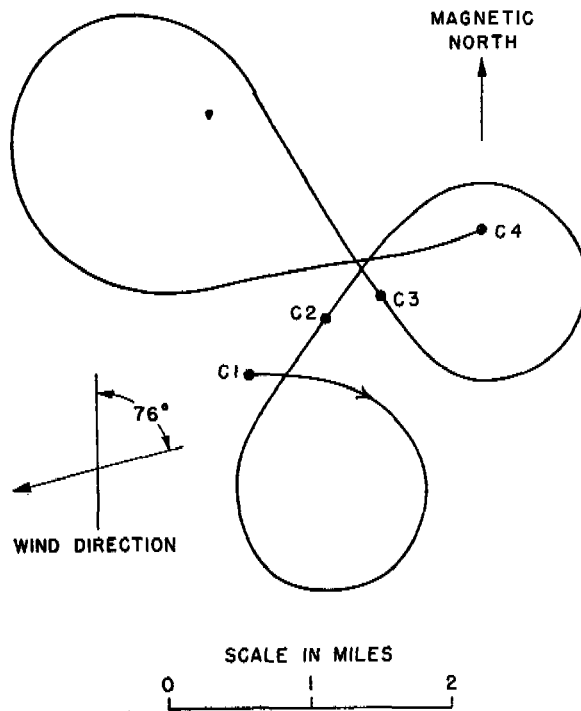

FIGURE 48. Odograph map in B-18 Army bomber; C₁, C₂, C₃, C₄ are successive mappings of the same point. Wind vector can be derived from time interval and distances between successive mapped positions.

graph and were important in showing the general practicability of the device and the desirability of including a device for setting wind

stallation used the Pioneer fluxgate compass, the Schvien true airspeed meter, and the IBM disk drive integrator with provision for wind

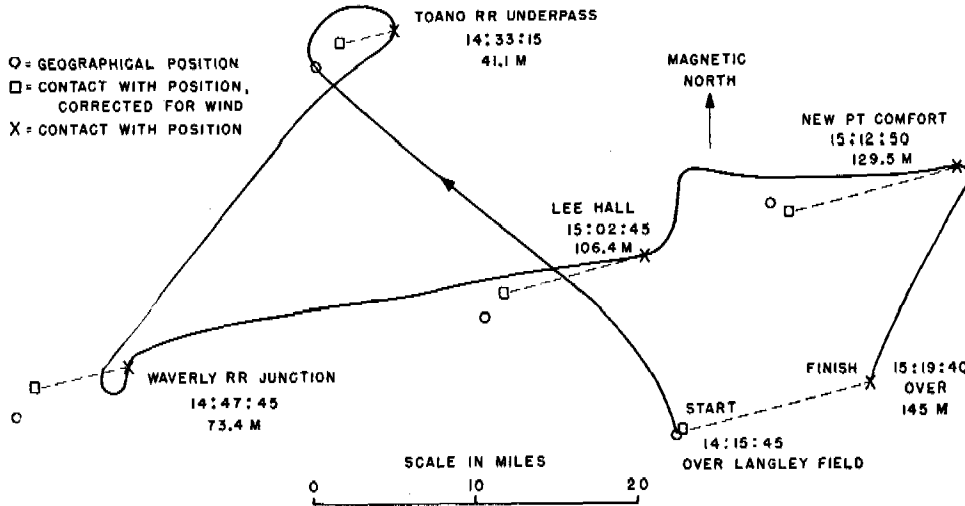

FIGURE 49. Odograph map in B-18 army bomber, showing positions as mapped, as calculated by allowing for wind drift determined by drift sights, and actual positions.

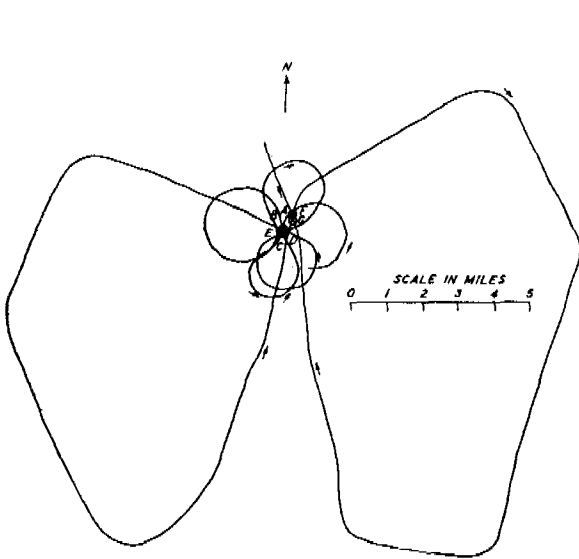

FIGURE 50. Odograph map in B-24 Army bomber, showing search flight with successive returns to the same point. Total flight 100.5 miles; closure error 1,150 yd, or 0.7 per cent.

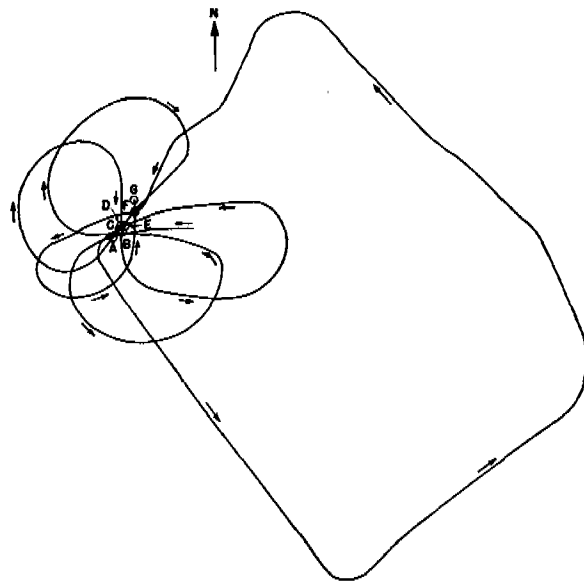

FIGURE 51. Odograph map in B-24 Army bomber. Successive returns to a wrecked ship. Total flight 104.9 miles; closure error 2,280 yd or 1.2 per cent.

drift automatically (which was later incorporated into the integrator).

correction. The entire installation as used in this test (using the earlier, Type AO-2 integrator) weighs approximately 150 lb.

1.6.10

B-24 Army Bomber^{1h}

Test flights of an installation on a B-24 bomber were made in February 1943. The in-

The tests indicated good performance provided that the wind is accurately determined and the pilot flies ball-banked turns and maintains constant altitude. Under these conditions,

banks up to 60 degrees could be made, and the odograph would still function properly. After determining wind (in the manner indicated by Figure 44) and setting the wind correction into the integrator, some very good flights were made, as are indicated by Figures 50 and 51.

mileage unit, a quite successful map was made, as is shown by Figure 52.

These tests were of very limited scope and added little to previously available information concerning performance and utility of the instrument.

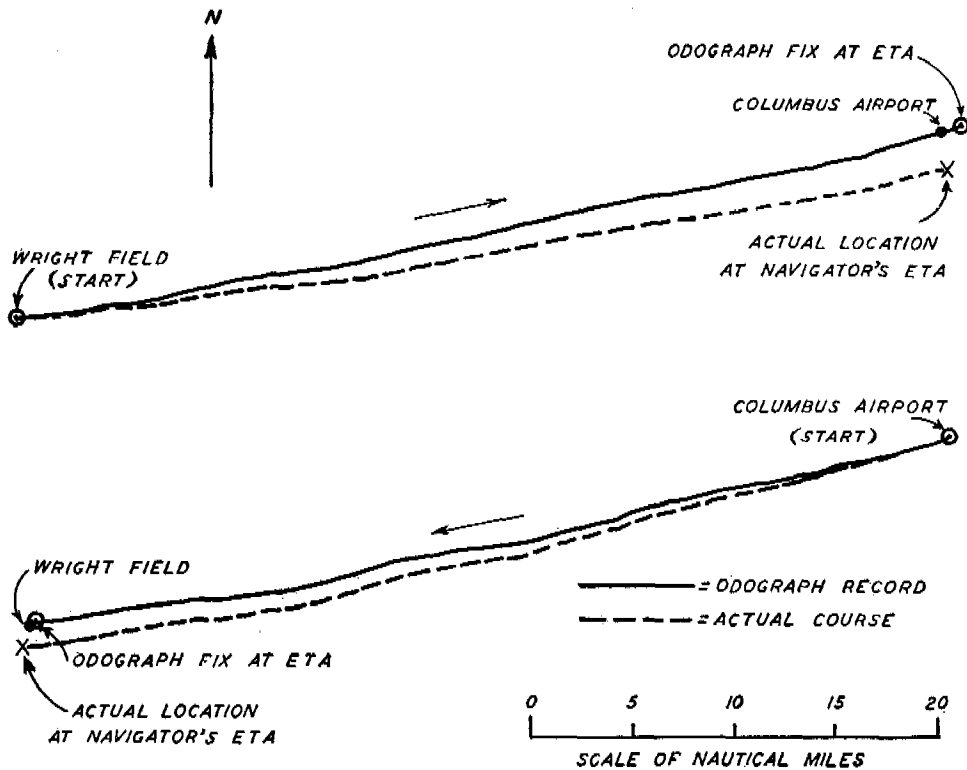

FIGURE 52. Odograph map in RA-29 for flight from Wright Field to Columbus and return. Wind correction from meteorological observations.

These were the first tests made with the inclusion of automatic wind drift correction and showed that very good maps could be made of the position of a plane with respect to the ground. It is probable (although not so recorded in the reports) that these tests were important in indicating performance good enough to stimulate the interest of the Services in this device.

1.6.11 Army Patrol Plane, Type RA-29⁹

This installation used the Pioneer fluxgate compass, Pioneer air mileage unit, and IBM disk drive integrator. After considerable trouble on account of the inaccuracy of the air

1.6.12

Model OA10 Aircraft (Flying Boat)⁷

This installation used a Pioneer fluxgate compass, a British air mileage unit, and IBM disk drive integrator with wind correction and remote electrically operated plotting table. Special items of installation included a pitot tube head, mounted above the bombardier's compartment, and watertight valves that had to be installed in the flushing lines of the air mileage unit so that these lines could be closed during landing or take-off on the water. The general nature of the installation is shown by Figure 53, with the auxiliary equipment shown by Figure 54. A number of difficulties with the acces-

sories, particularly with the air mileage unit and compass unit, were experienced with this installation, but these were finally eliminated and quite successful maps produced, as indicated by Figure 55.

These tests indicated at that time (November 1943) that the aerial odograph was a useful navigational instrument, capable of a high de-

made to determine: (1) the accuracy with which winds could be found with the odograph itself; (2) the possibility of using other than visual fixes for wind determination; (3) the usefulness of the odograph in dead-reckoning navigation; (4) the value of the instrument in supplying a record of a flight and, in particular, one in which a search is made; (5) the applica-

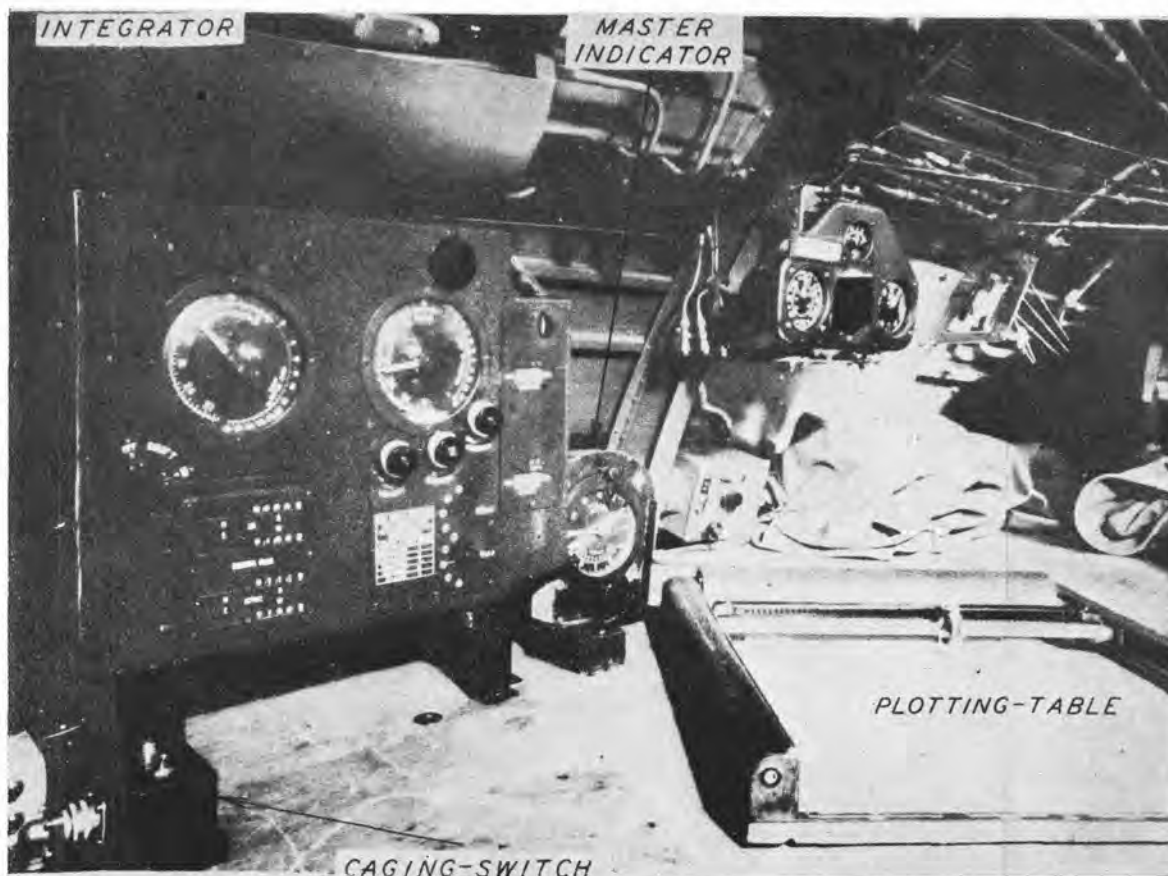

FIGURE 53. Odograph installation on Army Patrol Flying Boat (OA10 43), showing integrator, plotting table, caging switch for compass gyro, and master indicator mounted in navigator's compartment.

gree of accuracy when used with reasonable skill and care.

1.6.13 PBM-3S (Navy Patrol Flying Boat)⁸

This installation (December 1943) used a Pioneer fluxgate compass, a British air mileage unit, and IBM disk drive integrator with wind correction. The general arrangement of the installation is shown by Figure 56. The tests were

bility of the odograph to *magnetic airborne detector* [MAD] work.

In general, the results of this test were quite satisfactory, and an indication of the general nature of the mapping obtainable is shown by Figure 57. The manner in which the odograph may be applied to a search pattern is indicated by Figure 58, and the manner in which a MAD search might be conducted is simulated by following the course of a ship, as is indicated by Figure 59.

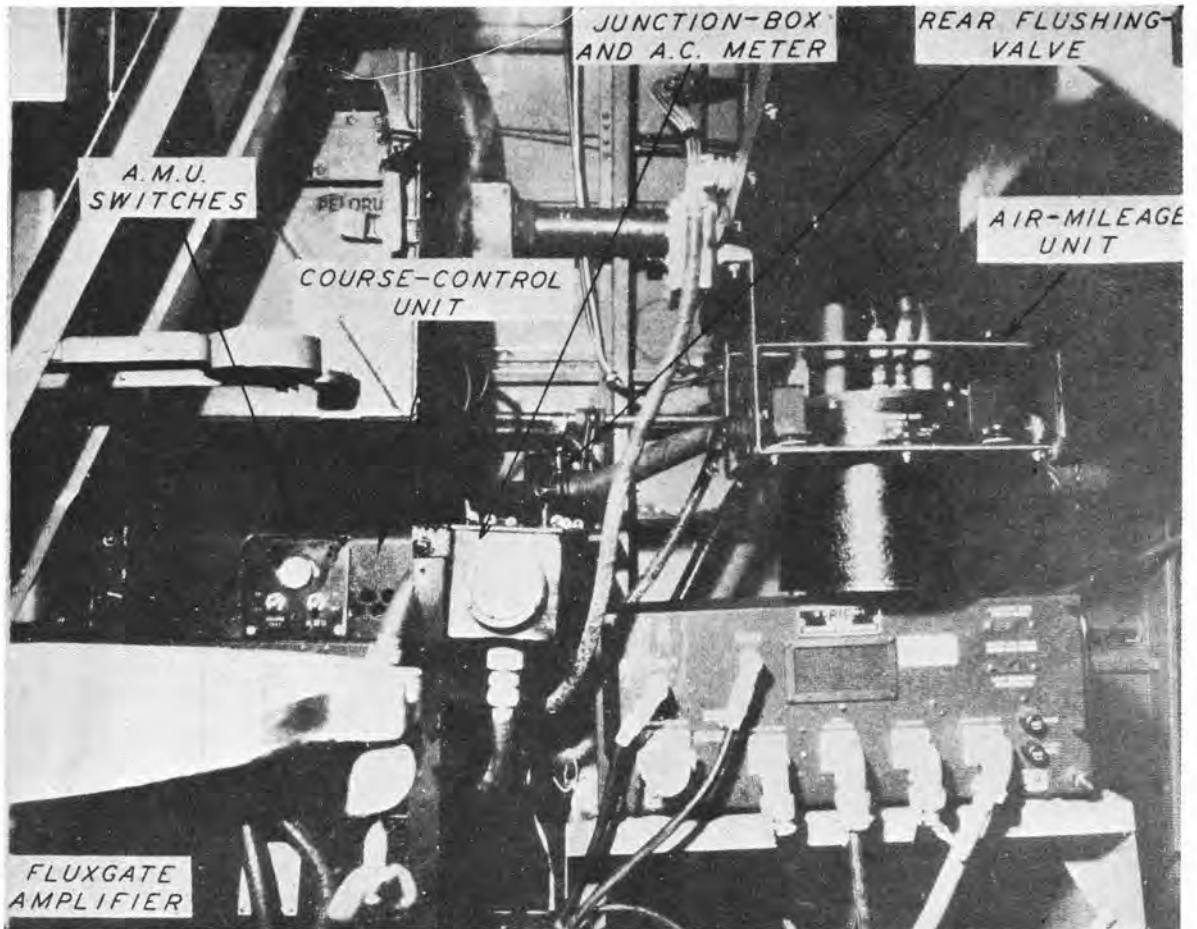

FIGURE 54. Auxiliary equipment for installation of Figure 53, mounted beneath navigator's table.

The tests indicated that wind determinations by means of the odograph could be made quite accurately, that radar and radio cone of silence may be used to find winds with an accuracy comparable to that obtained when using visual fixes, that in dead reckoning the odograph would be particularly valuable in case of evasive action, and that the instrument should be particularly valuable for search flights and MAD work.

1.7 MISCELLANEOUS DEVELOPMENTS AND TESTS

1.7.1 Lateral Activities within the Compass and Odograph Project

During the nearly five years in which it was active, many relatively minor development

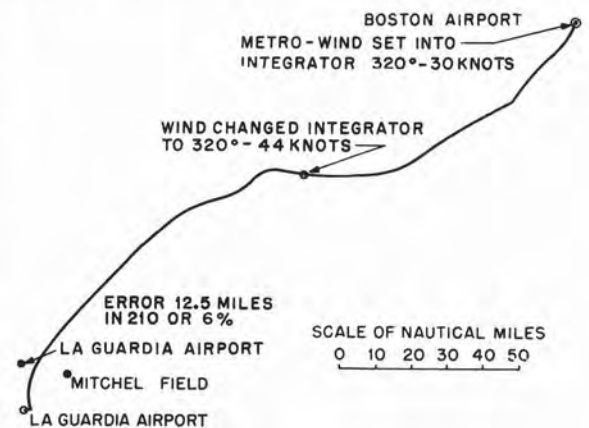

FIGURE 55. Odograph map made in test flight from Boston to New York.

projects were included within the general activities of the compass and odograph project.

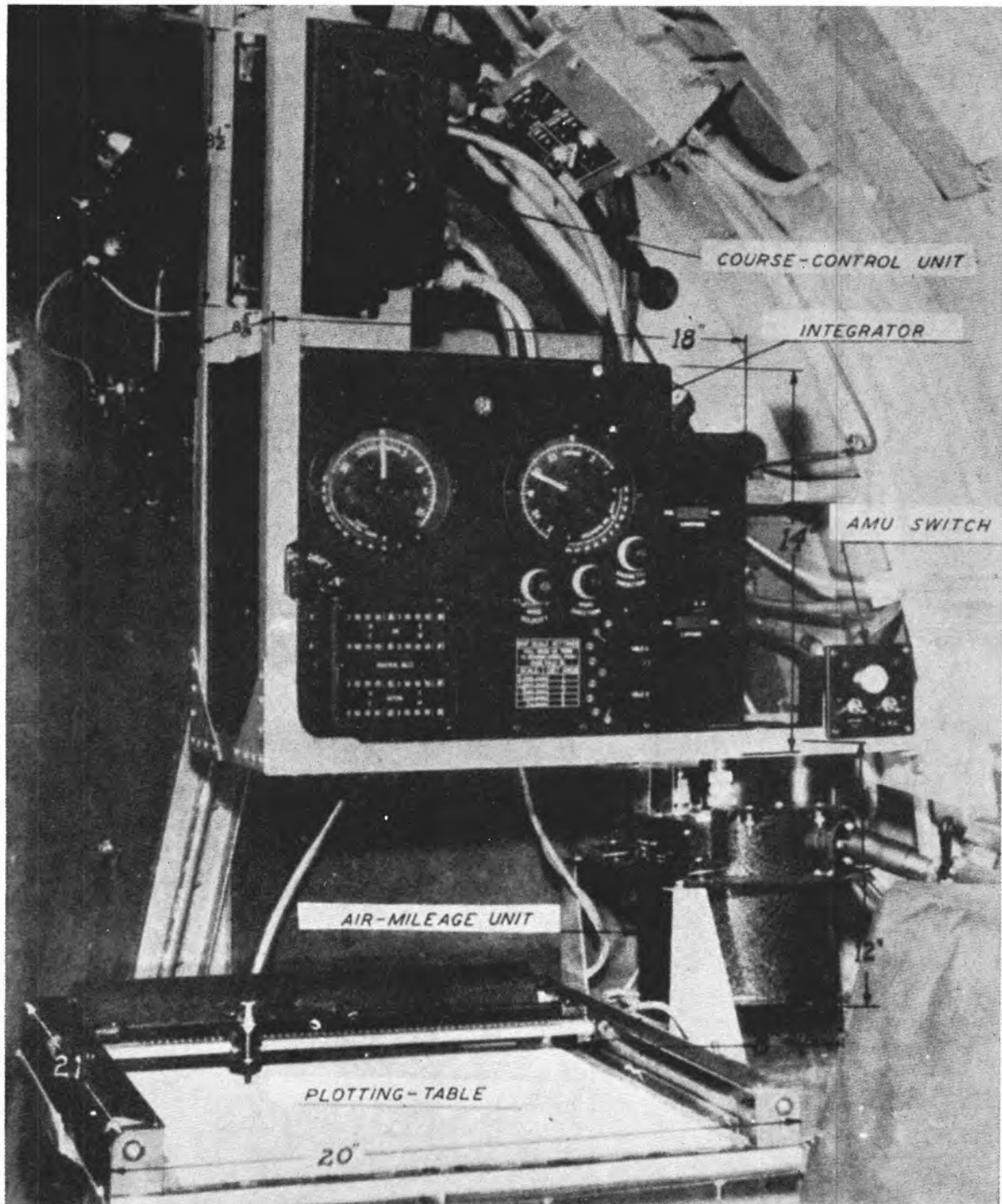

FIGURE 56. Odograph installation on Navy Flying Boat (PBM-3S).

~~CONFIDENTIAL~~

These were undertaken either because they were closely related to the principal developments or because the personnel of the project

Those that are included are more or less definite and completed projects which are mentioned in the various current reports.

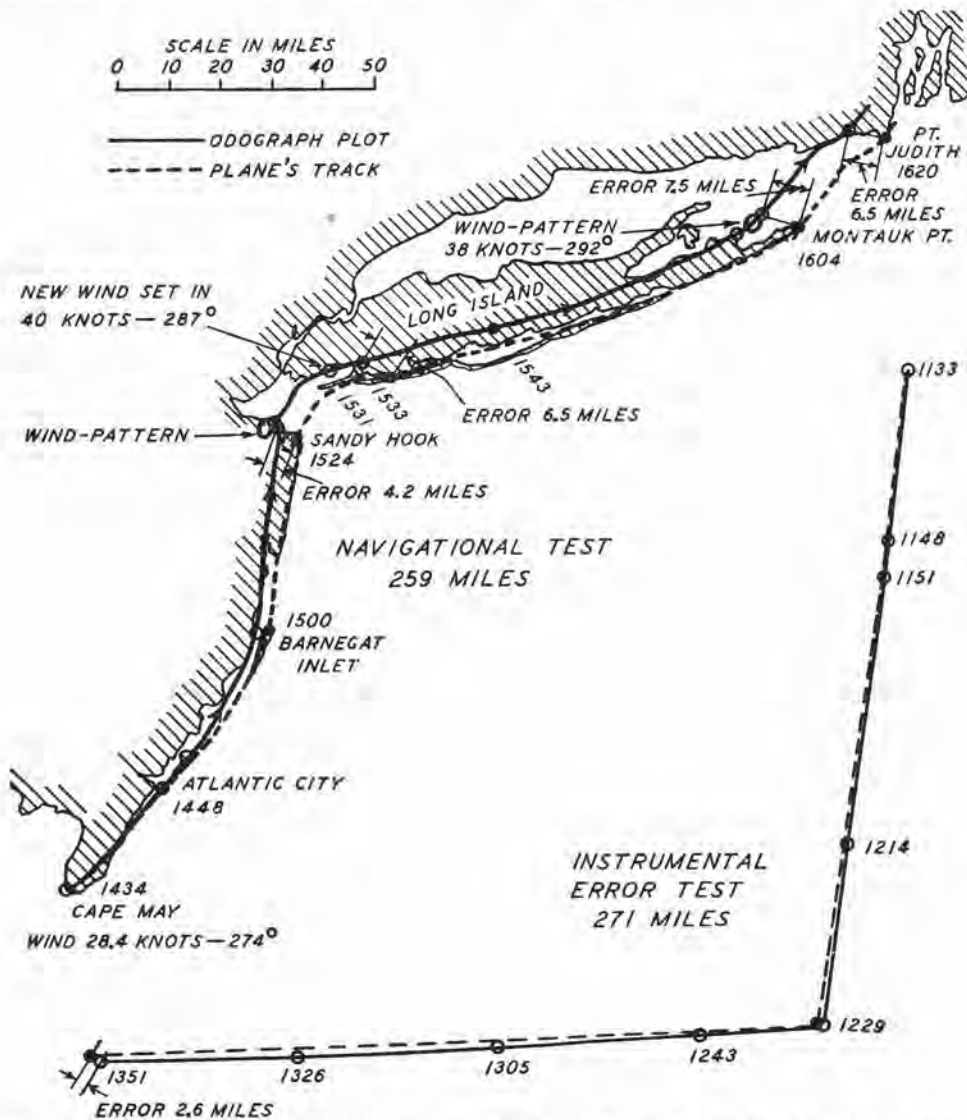

FIGURE 57. Odograph map made in navigational flight from Point Judith to Cape May for comparison with navigator's dead-reckoning and return flight from Cape May to determine odograph error.

were particularly well suited by training, experience, and equipment to undertake them. Many of these smaller jobs were taken up as a result of direct requests from the military Services.

Of necessity, many of the smaller side-line investigations and developments, many of which because of their failures were useful mainly in negative ways, are not included in this report.

1.7.2

The Pedograph¹³

The pedograph is essentially a small odograph designed to be carried by a man on foot and to make a map of the course he travels. While such a development was considered in the earlier days of the odograph project, it was not actually undertaken until requested by the Army after interest was aroused by the cap-

ture of a Japanese instrument which performed this function.

PRINCIPLES OF OPERATION

In the pedograph, a simple magnetic compass gives the reference direction. The servomechanism is replaced by the operator himself who

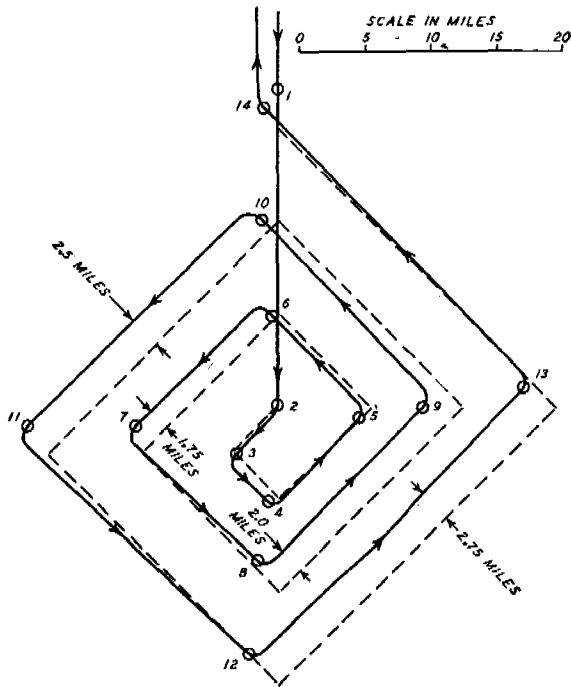

FIGURE 58. Map of search pattern, using odograph for control. Solid line: odograph trace; dashed line: navigator's dead reckoning.

turns a cover over the compass to keep a reference line on the cover parallel with the compass needle. The distance is given by a thread which is pulled out from a spool in the instrument and over a pulley which is thus rotated by an amount proportional to the distance traveled.

The manner in which these two functions are integrated to make a map is indicated by Figure 60. The paper on which the map is drawn is carried on a cylinder or platen which is free to rotate and also to move longitudinally along the platen shaft. A plotting wheel in contact with the paper is oriented by the rotation of the compass follower. This wheel is turned by reduction gears connected directly to the grooved pulley over which the distance-measuring thread is paid out so that the rotation of the plotting wheel is directly proportional to the

distance traveled. If the axis of the plotting wheel is parallel to the platen shaft, the platen will rotate about the shaft. If the axis is perpendicular to the platen shaft, the rotation of the plotting wheel will cause the platen to move longitudinally along the shaft. At intermediate positions, the rotation of the plotting wheel causes a combination of rotation and longitudinal movement of the platen and thus resolves the motion into components parallel and perpendicular to the platen shaft, thereby performing the required functions of the odograph integrator. A fixed pencil will then make a trace on the map paper which will record the motions of

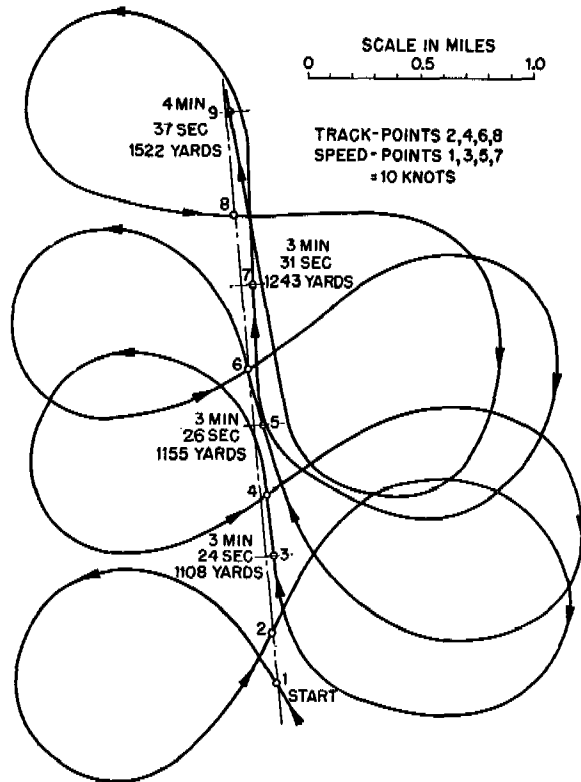

FIGURE 59. Simulated MAD search. Circles show successive observations on a moving ship, from which its speed and course were determined.

the cylinder under the pencil and thereby trace a map of the course over which the instrument is carried.

THE COMPLETED INSTRUMENT, ACCESSORIES, AND TESTS

The general construction of the instrument as actually built, and using the principles indi-

cated by Figure 60, is shown by Figure 61. In addition to the fundamental requirements, the completed instrument contains, as accessories, an automatic threader which facilitates passing

by the simple expedient of providing two driving pulleys of different diameters.

The instrument uses standard cotton threads and sizes from No. 40 to No. 60 produce good

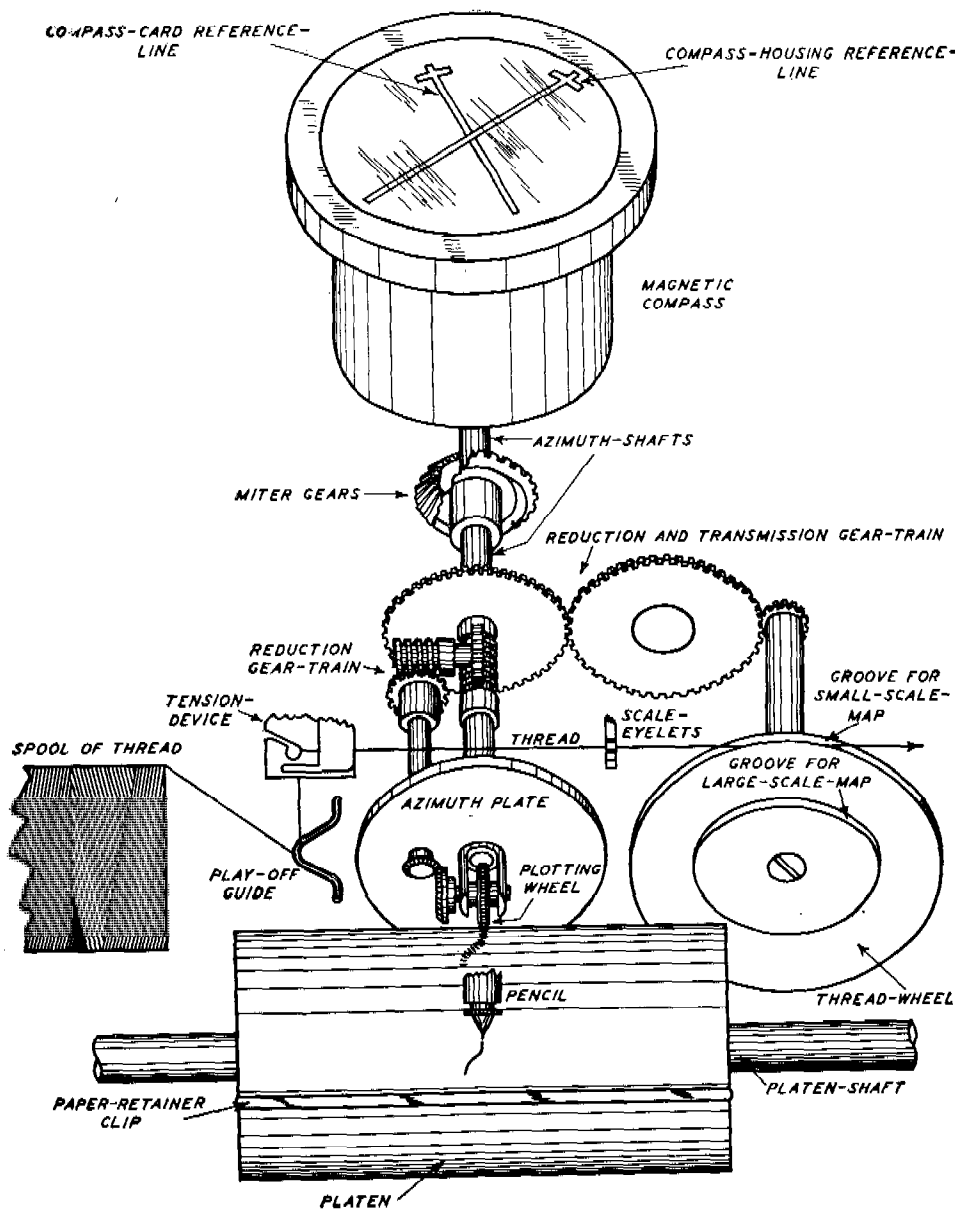

FIGURE 60. Schematic diagram of pedograph, showing general principles of operation.

the thread through the guides and around the grooved pulley, a marking device which permits reference marks to be placed on the map by a knob on the outside of the instrument, and small flashlight lamps for illuminating part of the map surface. Two different scales are provided

results. Number 40 thread with a tensile strength of about 3 lb was adopted as standard. (A spool holding 2,000 yd of camouflage thread was specified.) Map paper size is about 6x11 in. Total weight of the instrument is 6½ lb.

A number of tests of the instrument were

made in a rough wooded area. These indicated an average accuracy based on errors of closure of somewhat better than 3 per cent. Procure-

the map, and this disk is kept oriented so that reference lines on it are parallel with a reference direction given by the compass.

PRINCIPLES OF OPERATION

The general principle of operation is indicated by Figure 62. The ratchet, which is moved one or two notches by each step of the operator, turns a knurled driving wheel operating on the lower side of the disk of map paper. Opposite the knurled driving wheel is a knurled inking wheel which makes a trace of the course on the upper surface of the map paper. A thumb knob

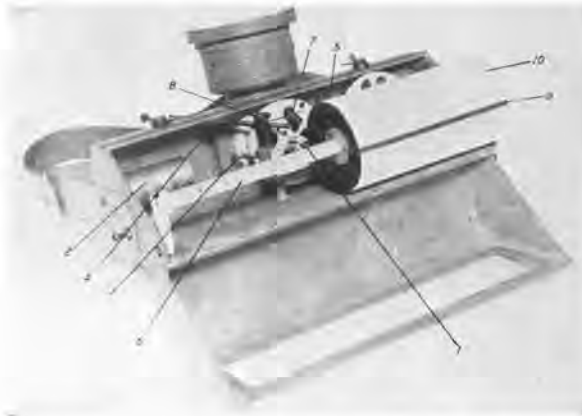

FIGURE 61. Oblique front view of pedograph with cover open and platen at extreme right end of platen shaft. (1) Plotting wheel, (2) spool of thread, (3) play-off guide, (4) tension device, (5) scale eyelets, (6) platen shaft, (7) pencil, (8) light, (9) trace sheet retaining clamp, (10) platen.

ment of these instruments was started, and they were used in some quantity by troops in the Pacific theater shortly before the end of the war.



FIGURE 63. Top view of step-writer. (1) Thumb screw for orienting map paper, (2) knurled inking wheel, (3) plunger for distance input, (4) map paper, (5) compass needle.

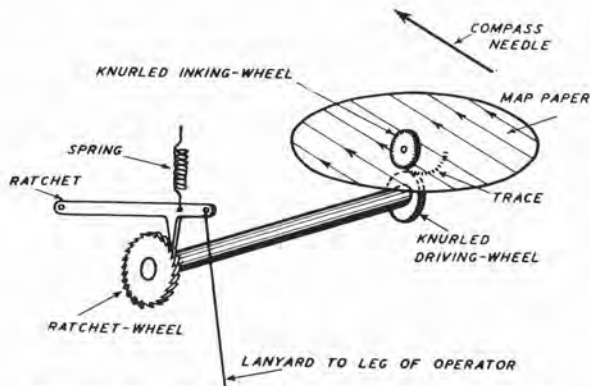

FIGURE 62. Schematic diagram of step-writer, showing general principles of operation.

1.7.3

The Step-Writer¹²

The step-writer is another type of odograph carried by a man on foot and performs the same function as the pedograph. The essential difference is that the distance is obtained from a ratchet operated by a line attached to the leg of the operator and that a simple disk is used for

on the outside of the case operates a roller by which the map paper is rotated about the point where it is held between the knurled driving wheel and the knurled inking wheel. The paper is held in the instrument below a compass in a transparent case, Figure 63. Thus, if the operator manipulates the thumb knob so that the reference lines on the map paper are always parallel with the compass, the motion of the paper beneath the knurled inking wheel will always be in a direction corresponding to the direction in which the operator is traveling.

CONSTRUCTION, ACCESSORIES, AND TESTS OF THE INSTRUMENT

As made, the simple step-writer does not provide for producing a map at a standard scale.

The scale depends upon the average length of stride of the operator. Two scale ratios are provided by means of a device which limits the motion of the ratchet so that the wheel is moved by either one or two teeth for each step. The gearing is such that the instrument gives map scale ratios of 1 to 20,000 or 1 to 40,000 for a 30-in. step. The compass was a special development and consists essentially of a magnetic needle in a bowl of transparent plastic filled with kerosene for damping. The total weight of the instrument is 4 lb. The circular map paper has a diameter of 3½ in. (which corresponds to a distance of about 1 mile, at scale 1:20,000 and about 2 miles at 1:40,000).

Field trials indicated that over moderately smooth territory a closure error of the order of 1 per cent would be expected. The effects of going uphill or downhill were checked and, rather surprisingly, it was found that there was little difference in the length of a step and therefore in the precision of the instrument. Tests with the operator walking through underbrush showed that after some experience the average step in the brush was only some 2 to 5 per cent shorter than on a road.

In general, the step-writer is considerably less precise than the pedograph and has the further disadvantage of a much smaller mapping area (3½-in. circle vs a 6x11-in. rectangle). It has the advantage of lighter weight (4 lb vs 6½) and, from a military standpoint, the very important advantage of having no telltale thread.

1.7.4 Miscellaneous Supplementary Developments

LANDING CRAFT COMPASSES¹⁶

A special compass for landing craft was developed to have a period of oscillation that would not respond to the usual period of roll of landing craft. A production model similar to the prototype developed under the compass project was manufactured by the Navy in large quantities for use on landing craft, PT boats, and other vessels.

REDESIGN OF No. 1 COMPASSES¹⁶

Under the compass project, DTM partici-

pated in the redesign of the Navy No. 1 (7½-in.) compass. Modifications of the magnet and damping system and compensating system greatly reduced the spurious deviations from various sources. The modifications were adopted in the manufacture of all compasses of this general type.

REDESIGN OF MAGNESYN COMPASS¹⁶

It was found that the magnesyn compass such as is used for a repeater indicator on ships was subject to serious oscillations from rolling of the vessel. A swinging mast some 45 ft high was constructed and used to test compasses, and, from these tests, the standard compass was modified to give greatly improved performance on ships.

DESIGN OF NEW 6-IN. COMPASS¹⁶

Design work and model construction were undertaken for a new compass with compensation based on experience gained in the general compass development. Its eventual use on many ships in the Navy is anticipated.

ODOGRAPH ATTACK PLOTTER¹⁶

In cooperation with the Underwater Sound Laboratory, the marine odograph was adapted to plot the attack of a ship on a submarine. This involved the construction of a separate stylus so that the position of both the attacking vessel and the submarine were shown continuously on the map.

1.7.5 Power Supply Sources and Converters

All the odograph installations require a special power source of some sort to supply electric currents at the voltages and frequencies required for the electronic tubes and other devices. Therefore, it is necessary to provide an accessory unit to convert the electric supply from the primary source (usually storage batteries) to that which is applicable to the apparatus.

For the vehicular odograph installations, a commercial power supply unit (manufactured by General Electric Company) was used with some modifications. This operates on the same

general principle as the power supply units used for automobile radios wherein a low-voltage, direct-current supply from storage batteries is converted, by the use of a vibrator and appropriate amplifier and filter circuits, into the high voltage required for the thyratrons and other electronic tubes and apparatus used in the equipment.

For the airborne installations, the fluxgate compass requires an electric supply at a frequency of 400 c. The same supply is required for certain repeater compass installations on ships which use the autosyn motor principle to repeat the compass indication at various points.

Ordinarily, this 400-c supply is provided by means of a rotary converter which is part of the aircraft equipment and which was not part of the odograph or compass development.

One special development¹¹ in power supply units which was undertaken under the compass project was that of providing an electronic inverter to take the place of the rotary converter to furnish the 400-c supply for repeater compasses on ships. The electronic inverter developed under this project is somewhat more flexible as to primary power supply than the rotary converter and furnishes an output with somewhat better electrical characteristics.

Chapter 2

T-58 PHOTOFLASH FUZE

By *George E. Beggs, Jr.*^a

2.1

INTRODUCTION

THE PURPOSE of this project^b was to develop a means of synchronizing the firing of a falling photoflash bomb with the operation of an aerial camera located in the aircraft from which the bomb was released. Further, it was required that the equipment be designed for automatic sequential release and firing of a number of bombs, i.e., firing in train. In other words, bombs were to be released automatically at constant intervals and fired in turn automatically after a given time delay. At the same time, the camera shutter was to be operated automatically at the correct instant to synchronize with the firing of each bomb. The release and firing delay intervals were to be adjustable independently in increments of 1 second from 5 to 90 seconds. Synchronization was to be accomplished to an accuracy of a few milliseconds. Such operation would make possible exposures at any desired rate and at any altitude within the ranges normally required.

Early attempts at night photography involved the obvious exposure method of opening the camera shutter and allowing the duration of the bomb flash to determine the exposure, after which the shutter would be closed. Such procedure produced blurred images because of the motion of the plane, making high-definition photography impossible at high altitudes. The problem became more and more serious as higher-speed planes were used for photographic work and as more and more night photography became necessary because of changes in theaters of operation. A later solution of the problem of synchronization was attempted by the introduction of a photocell to control the camera shutter, the photocell being actuated by the initial light from the bomb. This method proved reasonably satisfactory from the standpoint of synchroni-

zation, but it did not allow the firing of more than one bomb at a time for increased illumination in a given picture. Also it did not circumvent the problems of jamming caused by searchlights, anti-aircraft bursts, and other extraneous light sources.

It was obvious that to take full advantage of the possibilities of night photography, the camera shutter should be opened only for a brief exposure during the peak light intensity of the photoflash bomb, and the system should be relatively free from jamming and should allow the control of one or more bombs in salvo or in train.

Numerous methods of accomplishing the desired results, more fully outlined in Section 2.2, were considered and several attempted. The final apparatus, which performed successfully in initial field tests, consists of the T-58 fuze with an associated time delay arming device known as the T-4, the synchronizer, the radio transmitter, the intervalometer, and associated controls within the aircraft. This apparatus operates on the principle that basic control is established by the transmission of a coded radio pulse from the aircraft to the bomb. This radio pulse initiates the action of the bomb by means of a radio receiver and control circuit contained in the T-58 fuze. This same pulse activates the camera shutter with appropriate time delay to account for mechanical delays within the rest of the system and for delays within the bomb ignition train itself.

2.2

MILITARY REQUIREMENTS

The original military requirements were submitted as Service Project OD-141 on October 4, 1943, by the Office of the Chief of Ordnance. They were originally established by the Army Air Forces, as the branch of the Armed Services initiating the request for the new type of

^a Technical Aide, Section 17.1-17.2, NDRC.

^b OD-141.

ordnance equipment. The requirements set forth in the original correspondence are listed below:

1. Synchronization shall be effected by an improved method, initiated from either member of the bomb-camera combination to the other member.

2. There shall be provision for adjustment (after take-off of the airplane) of the time delay between release and burst of the bomb over a range between 15 and 90 seconds.

3. There shall be provision for optional opening or closing of a magnetic circuit in the camera to initiate action of the shutter at an instant selectively variable between 0.003 second before and 0.005 second after the initial emission of light from the photoflash bomb.

4. There shall be a time delay safety provision equivalent to the spinner action on the M111 fuze, to prevent premature arming and firing of the bomb.

5. The apparatus shall operate for any space between bomb fuze and camera up to 45,000 ft. All component parts must perform satisfactorily between the temperature limits of -40°F and $+70^{\circ}\text{F}$.

6. The equipment shall be of such nature that it can be successfully stored for prolonged periods at temperatures between -65°F and $+160^{\circ}\text{F}$.

7. There shall be protection against any possible interference from enemy or from other sources.

8. Provision shall be made for preventing premature operation of the photoflash bombs during descent on occasions when several bombs may have been released in train. Under such conditions, no bomb is to function until it has accomplished the required descent.

9. The firing mechanism is to function upon impact if the bomb falls to the ground in armed condition. Since the characteristics of photoflash powder are such that safe dropping of the bomb with such loading cannot be guaranteed when released from a height of 8,000 to 10,000 ft onto normal soil, the fuze is not required to withstand impact when dropped "safe" from these heights. The fuze shall, however, be capable of being dropped 25 ft onto a hard surface without functioning.

2.3 SUMMARY OF DEVELOPMENT

Consideration of the military requirements made it apparent that there were several methods of attack which might satisfactorily meet the majority of them. It was quite apparent that radio control of the system was most desirable, in view of previous work in the field of photoflash synchronization and available data on small electronic components for use in airborne vehicles such as a bomb. One of the major problems presented was the determination of whether the control should be from bomb to camera or from camera to bomb. Practical consideration of these two methods led to the choice of the latter, for a number of reasons. There was, for instance, the problem of simultaneous firing of several bombs in salvo. Also, high-altitude night photography required that the distance between the camera and the photoflash bomb be of the order of several miles (45,000 ft). Sufficient radio-frequency power to bridge this gap requires transmitting equipment too bulky and heavy to be accommodated in the bomb without increasing its physical size and shape materially. Thus it was decided to place the heavy transmitting and control equipment in the aircraft and to equip the bomb with a small, simple, and relatively insensitive radio-operated receiver-type fuze, designated as T-58. The automatically keyed transmitter emits an r-f pulse of approximately 2 milliseconds' duration, appropriately coded by various means to prevent easy jamming of the radio signal.

The major development was divided into a number of individual ones corresponding to the following units of equipment: (1) multiphase intervalometer, (2) synchronizer, (3) radio transmitter, and (4) bomb fuze receiver. These units perform widely different functions, some mechanical and others electric.

The multiphase intervalometer is an apparatus which determines the rate at which the bombs are released, the delay in firing after release, and the rate at which photographic exposures are made. In normal operation, it would be preset before take-off according to the requirements of the photographic mission. It is adjustable in increments of 1 second from 2 to 120 seconds.

The synchronizer is a unit which provides electronically a time delay between the firing of the photoflash bomb and the operation of the camera shutter. The purpose of the delay is to cause the exposure to occur during the optimum period of light. The delay is necessitated by the fact that mechanical inertia within the shutter

and delay within the bomb ignition train make it impossible to transmit simultaneously pulses for control of both items. The synchronizer is adjustable in increments of 2 milliseconds from 5 to 25 milliseconds, thus allowing adjustment for different types of photoflash bombs and cameras.

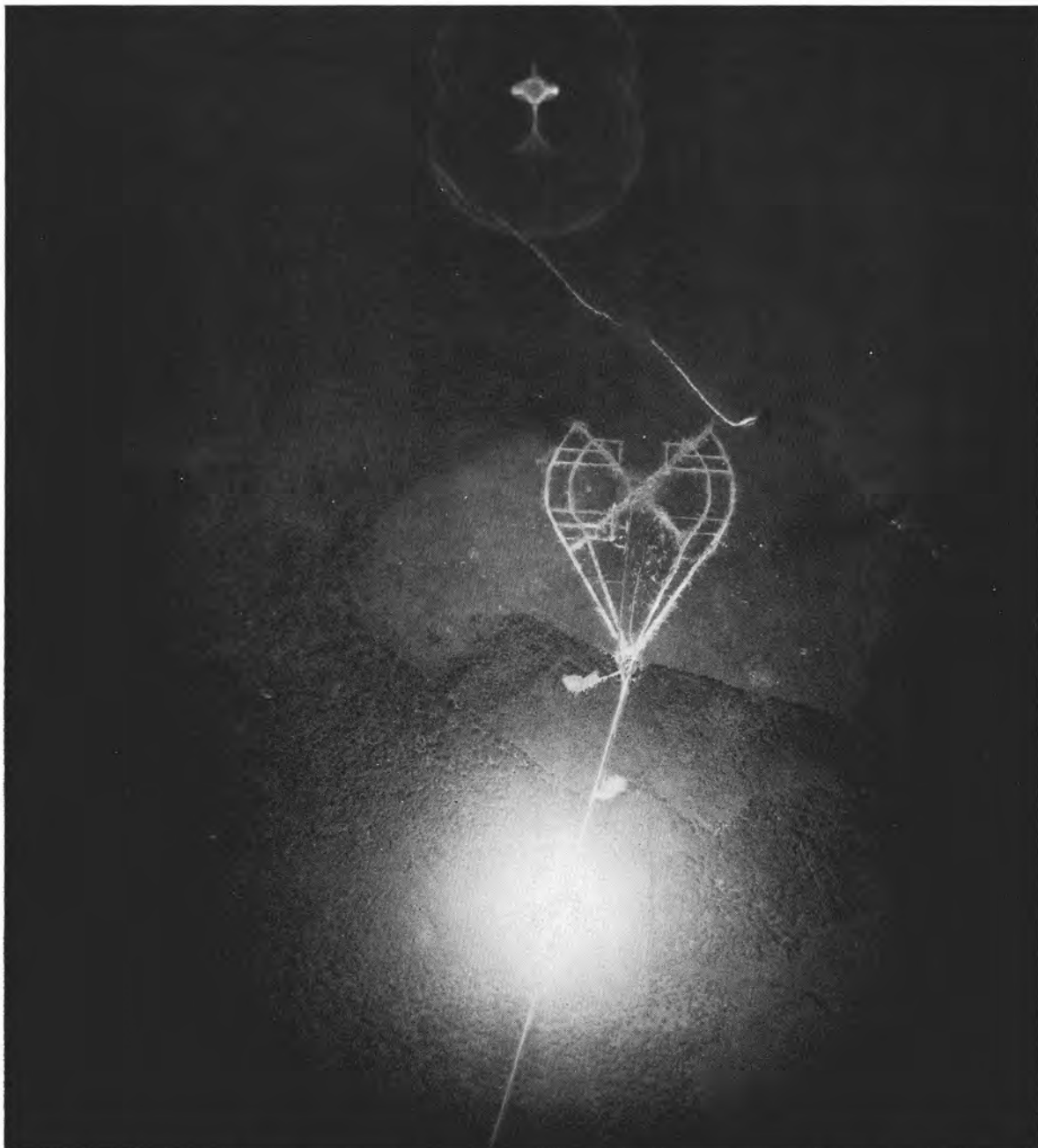

FIGURE 1. Photograph taken during Test 5 (photograph by Ballistics Research Laboratory, Aberdeen Proving Ground).

The radio transmitter emits a 2-millisecond pulse signal whenever keyed by the synchronizer. At all other times, there is no emission from the radio transmitter. Transmission is at a radio frequency of 120 to 130 mc.



FIGURE 2. Airborne multiphase intervalometer.

The bomb receiver is built into a radio-operated fuze which replaces the standard M111-A fuze. The pulse received from the radio transmitter is rectified by means of a grid-leak detector, amplified, and applied to the grid of a thyatron tube to initiate the firing train.

These various items, when combined into a complete operating system, meet the majority of the military requirements. Field tests, as outlined below, were completed as part of the project. Eight tests are outlined. Six were conducted at Aberdeen Proving Ground, Maryland, with the assistance of the Ordnance Department; the other two, at Denver, Colorado, with the assistance of the Army Air Forces.

Test 1. Safe-Drop Test from Tower, Using Inert Loaded Bombs. In this test, ten bombs with completely operable fuzes were dropped from a tower at a height of 50 ft, to see if the impact would cause fuze operation. No fuzes operated.

Test 2. Arming Characteristics. With a setting of 90 degrees for the rotor containing the firing squib, a test was conducted to measure the time from release of the bomb from the aircraft to earliest possible fuze function. The controlling transmitter was pulsed approximately four times a second to allow determination of fuze function within 0.25 second after time of

arming. Arming-time delay was provided only by internal characteristics of the bomb involving the gear train powered by the wind-driven propeller on the generator and rotating the rotor through 90 degrees to the point of firing. M46 bombs were supplied with spotting charges for this test. It was found that under no conditions did the bomb explode too close to the aircraft from the standpoint of safety and that results were more than adequate from the standpoint of consistency.

Test 3. Accuracy of Synchronization. A ground test was conducted to determine the synchronization accuracy between the fuze firing, the bomb firing, and the camera shutter opening. A dummy bomb was utilized as a receiving bomb connected to an active bomb by twisted-pair wire to avoid destruction of a large number of test fuzes. The data were taken on a multichannel cathode-ray recording

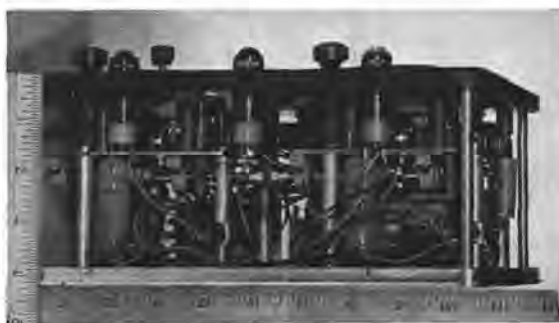

FIGURE 3. Side view of airborne multiphase intervalometer.

oscillograph. Synchronization of the order of 2 milliseconds, or better, was obtained in the numerous firings completed. Data on the accuracy and consistency of camera and bomb operation were also obtained.

Test 4. Radio-Link Range. A test was made to check the radio-link range using a B-17 aircraft with equipment installed and a standard fuze mounted well above the ground on an M46 bomb. Adequate operation over a range of 45,000 ft was obtained with the bomb and aircraft maintained in relative positions similar to those expected in actual practice.

Test 5. Check on Operation, Involving Single Bombs. This test consisted of a check on the operation of the apparatus by dropping single bombs (not several in train) and firing by radio

link. This test included taking of photographs. (See Figure 1.) Good synchronization was obtained, as checked by a recording cathode-ray oscillograph and a photocell at a ground location. The oscillograph compared the photocell pulse picked up from the bomb with a pulse from a contact made during the camera shutter operation.

Test 6. Check on Operation, Involving Three Bombs in Salvo. The final test at Aberdeen involving the dropping of three bombs in salvo was successfully completed with all bombs fir-

2.4 DESCRIPTION AND TECHNICAL INFORMATION

2.4.1 Multiphase Intervalometer

The multiphase intervalometer, illustrated in Figures 2 and 3, is made up of three mechanical timing devices driven by a single 28-volt d-c motor. Essentially, the device must perform the following functions. After a starting signal is received, it must operate periodically at some predetermined time interval. It must perform

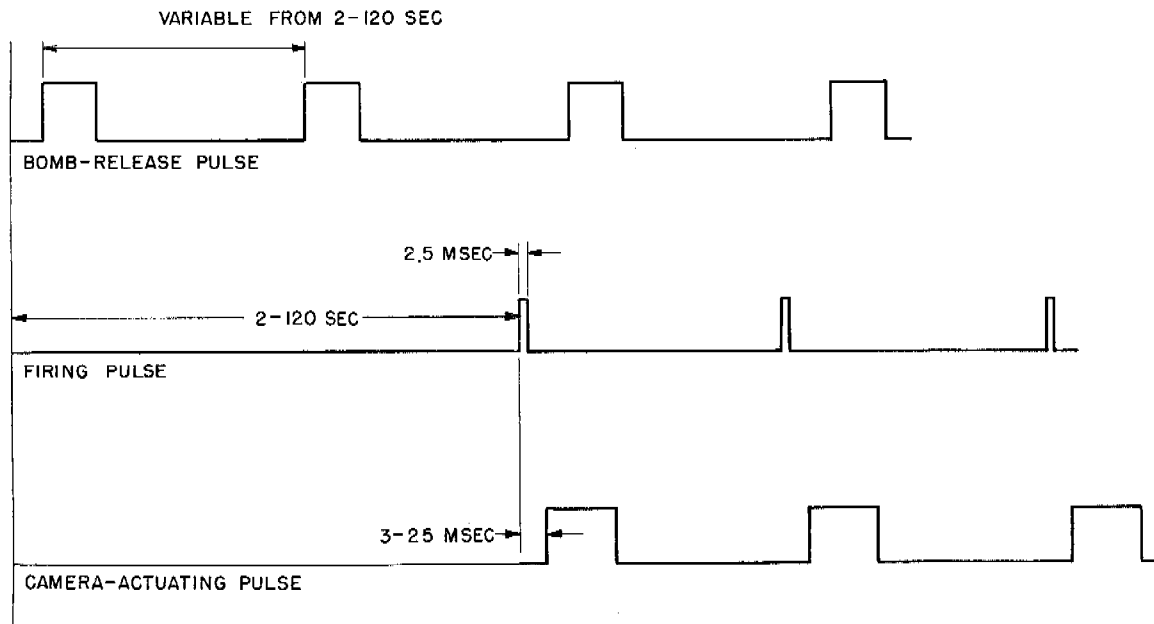

FIGURE 4. Pulse sequence for intervalometer and synchronizer.

ing simultaneously and with good synchronization. Pictures taken indicated far more light than expected, producing overexposure of the initial pictures taken under the same conditions.

It might be mentioned that during the first six tests of the last 39 fuzes, 34 performed perfectly. The failures in the first few fuzes were due to oscillation of the bomb, apparently caused by incorrect trail plates. These plates were later corrected, so that 100 per cent operation was obtained in the last 30 drops.

Tests 7 and 8. Overall Flight Tests. These tests consisted of a final check on the apparatus wherein bombs, dropped and fired in train, were used to take pictures to see if the complete system sufficed for actual night photography of a reasonable area of ground. These tests were completed fairly satisfactorily at Denver.

a second operation sometime later without any interference between the two operations. Finally, it must repeat the complete cycle for a considerable time. Such a sequence of events is required since on a typical mission it might be necessary to release bombs and make exposures at intervals of 10 seconds, with the exposures coming 35 seconds after each bomb is released. Under these conditions, since the first bomb was released at "zero" time, four bombs would be in the air before the first one was fired. After the first firing, succeeding bombs would be fired at 10-second intervals. Control of release and firing pulses for this type of operation can be obtained with the multiphase intervalometer noted. Construction is such that two Fairchild B-3-B intervalometer units are geared to one motor drive and modified to perform the re-

quired functions. This eliminates any possibility of lack of synchronization between two or more separate intervalometers driven by separate motors. The overall time accuracy is thus reduced to the time accuracy of one machine, and the lack of synchronism between the dropping and firing pulse is removed.

The output of this intervalometer provides

curately timed pulses: one which actuates the camera shutter, and another which keys the transmitter. Thus the intervalometer and the synchronizer provide three pulses: one which drops the bomb, one which actuates the radio transmitter, and one which actuates the camera shutter. The time delay between the last two pulses may be varied from 5 to 25 milliseconds

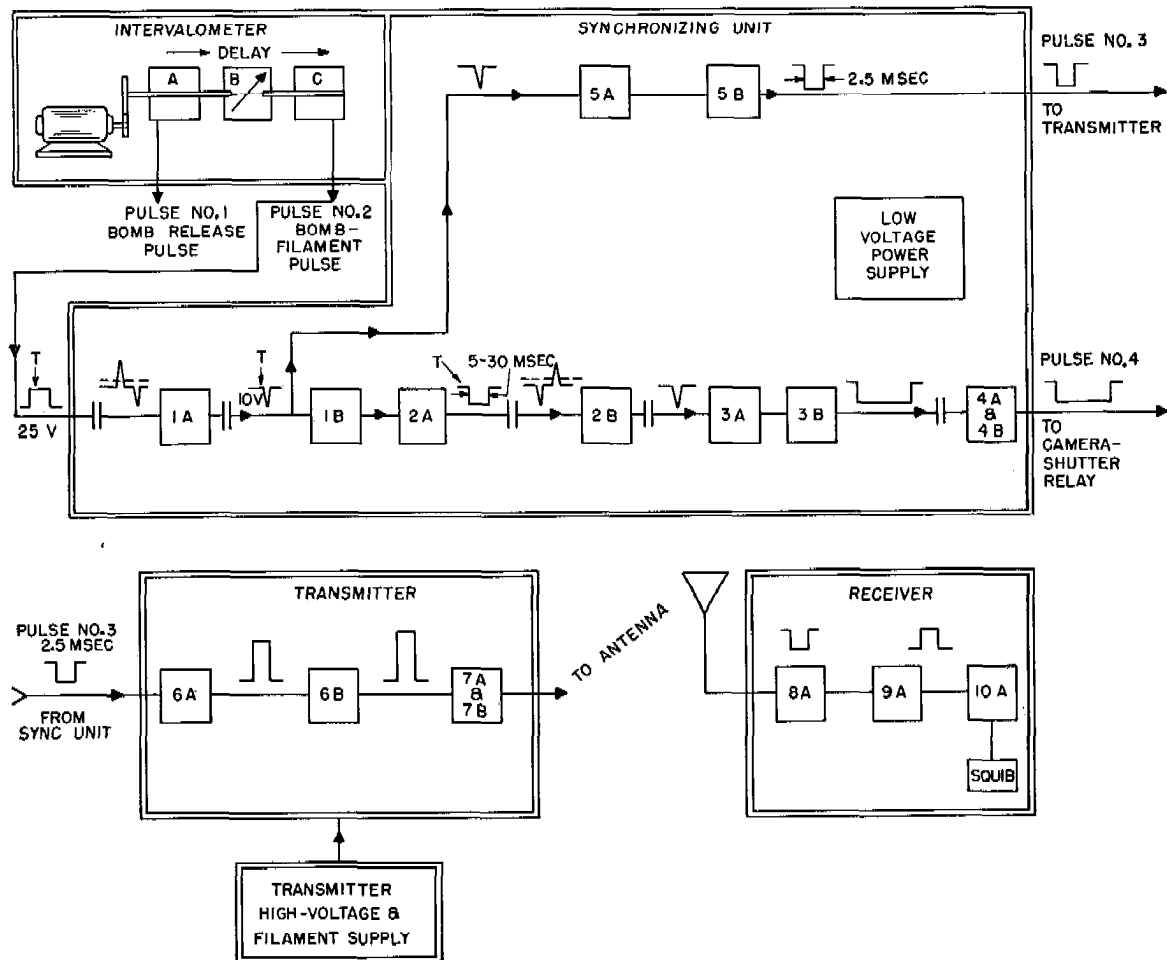

FIGURE 5. Block diagram of overall system in aircraft and in bomb.

two electrically isolated, mechanically timed pulses. The first actuates the bomb release mechanism; the second, the synchronizer unit.

2.4.2

Synchronizer

The synchronizer, or electronic time delay mechanism, receives an actuating pulse from the intervalometer and divides it into two ac-

in increments of approximately 2 milliseconds. Figure 4 shows the relative timing sequence: the bomb release pulse from the intervalometer, and the two synchronizing pulses from the synchronizer. Figure 5 is a block diagram for the overall system contained within the aircraft and within the bomb.

It was known that the bomb requires approximately 25 milliseconds to ignite and to reach the optimum light period and that the camera

shutter requires 10 to 12 milliseconds to open completely after receiving the actuating pulse. From these two figures, it is clear that, to obtain the desired synchronization, the camera

transmitter of this type, it was possible to use a single 829-B tube in the output and a relatively small low-current-type rectifier power supply. The transmitter pulse is modulated with

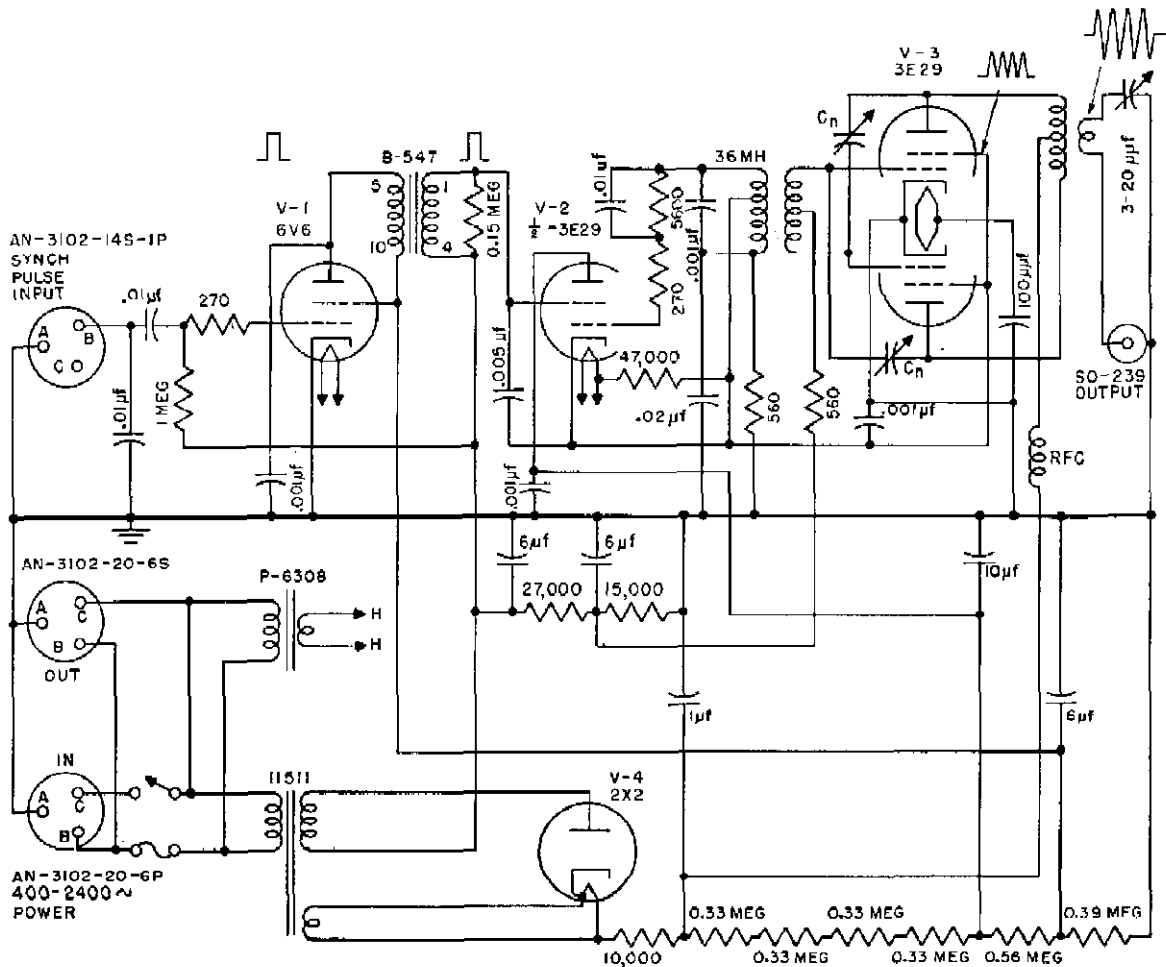

FIGURE 6. Schematic diagram of pulse transmitter.

pulse should be delayed some 12 to 15 milliseconds with respect to the firing pulse. This was confirmed in the Aberdeen tests mentioned in Section 2.3.

2.4.3

Radio Transmitter

The radio transmitter is a pulse-emitting type capable of delivering approximately 7-kilowatt peak r-f power at a carrier frequency between 120 and 130 mc. The transmitter has no emission whatever, except when keyed "on." In view of the extremely low-duty cycle of a

23 kc. The power supply equipment for the transmitter is such that it can produce full-power output pulses as rapidly as once every 5 seconds, which is the maximum rate of exposure of most standard automatic aircraft cameras, while more rapid pulsing may be obtained if less power output is acceptable. A schematic diagram of the pulse transmitter is shown in Figure 6.

2.4.4

Bomb Receiver

The bomb receiver is comprised of a complete

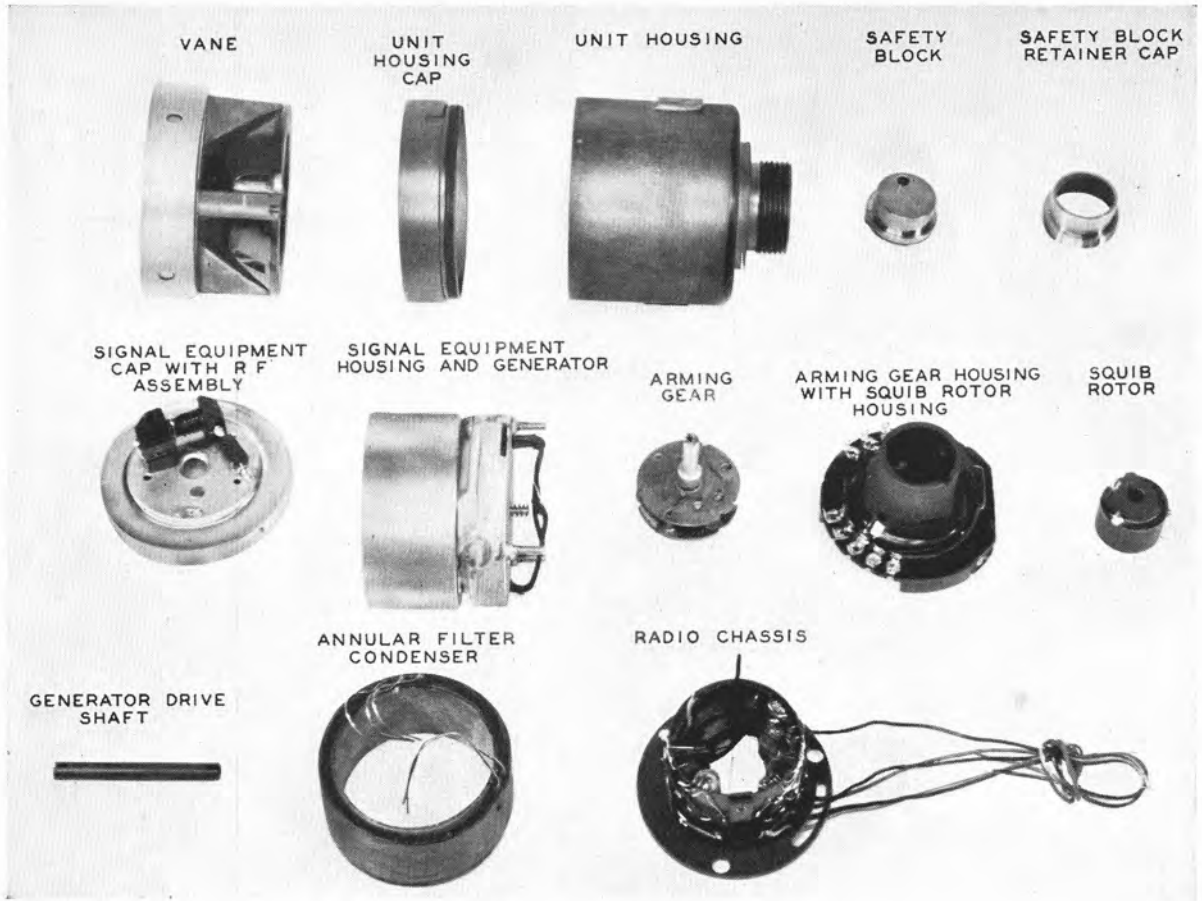

FIGURE 9. T-58 fuze components.

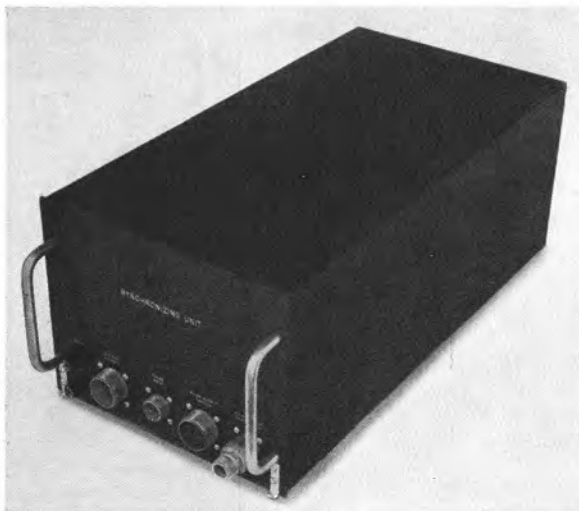

FIGURE 10. Airborne synchronizing unit.

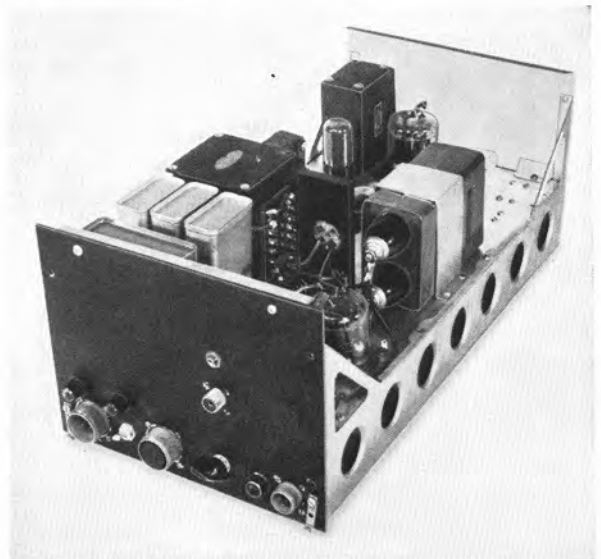

FIGURE 11. Airborne radio transmitter.



portion of the development are the items contributing to the difficulty of jamming the receiver or the radio-link operation. First, the radiation reception pattern of the bomb and the transmission pattern of the radio transmitter in the aircraft are such that they are mutually aiding but tend to exclude signals from other directions. These patterns were originally established by reference to bombing tables, to allow determination of bomb attitude and relation to plane at the desired point of firing. Since an *LC*-tuned amplifier with a *Q* (a figure of merit for a circuit, proportional to the ratio of the energy stored to the energy dissipated per cycle) of approximately 16 is used in the receiver, the enemy must satisfy a number of requirements in order to jam the operation of the unit.

1. The appropriate radio-frequency carrier must be located.

2. A pulse on this carrier must be initiated at a time when the bomb is in an armed condition.

3. The pulse must be of sufficient power to actuate the relatively insensitive bomb receiver under conditions unfavorable to the reception of a signal except from the plane.

4. The pulse must have 23-kc modulation.

5. The pulse must be of sufficient duration to allow the amplitude to build up in the tuned circuit.

All these features make it extremely improbable that jamming would prove effective, especially since the bomb is in an armed condition for only a few seconds prior to firing and since only a few bombs may be dropped on any one mission.

To allow adequate test of the apparatus, 135 T-58 bomb receivers were constructed and used in the field tests. During the construction of these units, under the supervision of the contractor, engineering details were worked out to allow reproduction of these fuzes in quantity. Two complete units of airborne apparatus were also completed in engineered form to allow their reproduction at will. Thus, at the conclusion of the project, successful tests had been completed on the method of synchronization and the safety of the device; engineered designs of apparatus were available; production problems had been

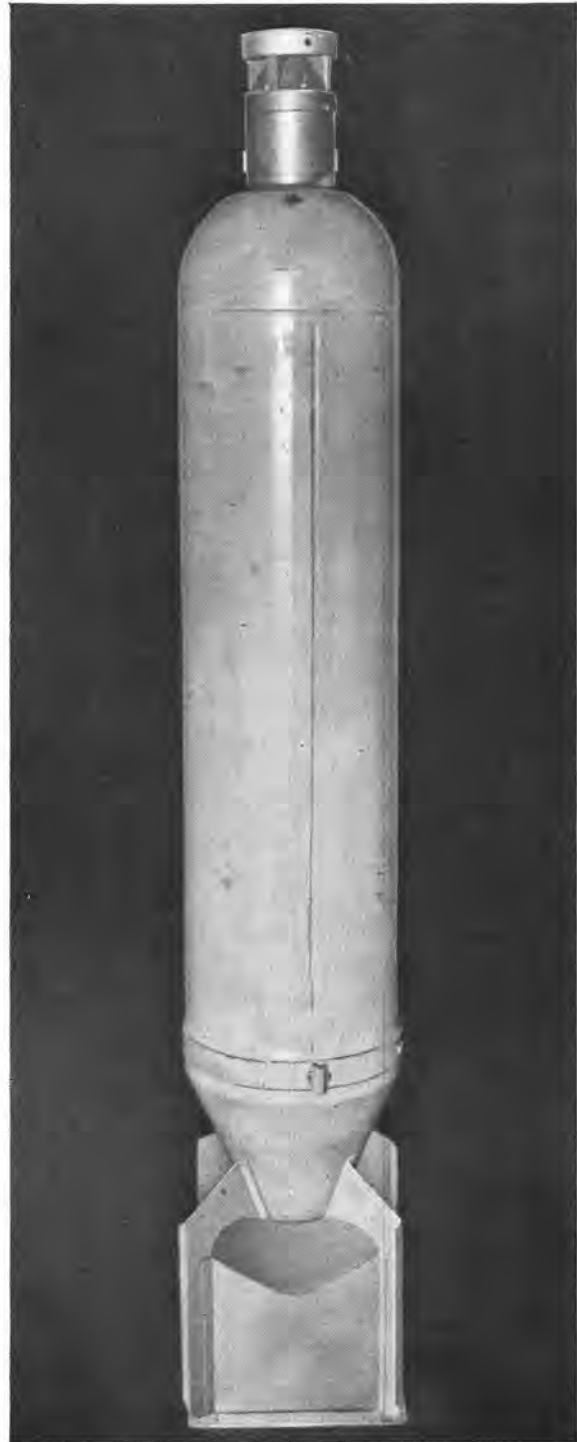

FIGURE 12. T-58 fuze mounted on M46 photoflash bomb.

worked out in some detail; and operational procedure had been clarified.

Chapter 3

OXIMETERS

3.1

INTRODUCTION

AN OXIMETER is a photoelectric device which measures the degree of oxygen saturation of the blood by measuring the percentage of red light transmitted by the subject's ear. It is based on the fact that reduced hemoglobin which is dark purple in color absorbs a much larger fraction of red light than does oxyhemoglobin which is bright red. In an ideal optical system with only two pigments present, absorption measurements at two suitably chosen wavelengths would completely determine the relative proportion of the two pigments. In a complex system such as the shell of the ear, which contains large and varying amounts of light-scattering material and highly concentrated packets of pigments, the quantitative relationships are uncertain. It has been found possible, nevertheless, by using an instrument which compares the transmission of red and green light by the ear, to measure the oxygen saturation of blood with an accuracy of about 4 or 5 per cent. This oximeter had been developed¹ before the beginning of the research under NDRC and had been calibrated by the analysis of over 100 blood samples taken from arterial punctures made at the same time as the oximeter readings. A number of such oximeters have been made and have been widely used in altitude chambers and in hospitals. Unfortunately this instrument makes use of a taut-suspension galvanometer which renders it unfit for flight use because of the vibration.

The instruments desired by the Air Forces were of two types. First was a device simple enough in operation to be used by a flier on regular combat missions which would warn him when the oxygen content of the blood fell below the safe level and which would give the warning in sufficient time for him to correct the situation. At the time the request was made, it was not known whether the oxygen supply system being introduced would prove entirely satisfactory, and it was thought advisable to have an independent check on the flier's condi-

tion. The instrument developed for this purpose was called the *oxygen want indicator*. Second was an instrument which should be as accurate and reliable as the oximeters already developed for laboratory use, but which should be so resistant to vibration and change of position as to allow it to be used in aircraft. It should be a recording instrument and require a minimum of attention. Such an oximeter was needed for physiological research studies of high-altitude flying and for the testing of oxygen equipment. This instrument was called the *flight research oximeter*.

3.2

OXYGEN WANT INDICATOR

It was realized early in the work that the easiest way to satisfy the requirements of size, simplicity, and ruggedness and still have an instrument which was capable of detecting gross changes in the oxygen content of the blood was to sacrifice the two-color principle used in the laboratory oximeter and measure the transmission of the red light only. The photocurrents produced by the red light are of the order of 10 microamperes and can be increased by increasing the area of the photocell, while those from the green light are roughly one-thirtieth as large. If only the red light is used, the photocurrents can be measured with a standard aircraft-type microammeter, and the difficulties of size and vibration avoided. Variations in the thickness of the ear are taken care of by setting the indicator at full saturation while the subject is breathing pure oxygen. The meter indicates the absolute change in the photocurrent rather than the relative change. There is, however, only a rather narrow range of ear thicknesses encountered, and there is a considerable gap between a safe oxygen concentration (92 to 100 per cent) and an imminently dangerous one (65 to 75 per cent). As a result, it is possible to design the indicator so that no one will be told he is all right when he should be warned, and no one will be warned when he is all right.^{5a}

The ear unit for the oxygen want indicator consists of a bank of four lamps outside the ear and a barrier layer photocell inside the ear.

a cross-sectional diagram of the ear unit. Figures 2 and 3 are photographs of the ear unit.

A specially designed iron wire ballast tube is used to drop the voltage of the plane's electric system which varies from 22 to 30 volts to the 6 volts needed for the ear lamp and to keep the lamp current constant regardless of variations in the supply voltage. Three different types of

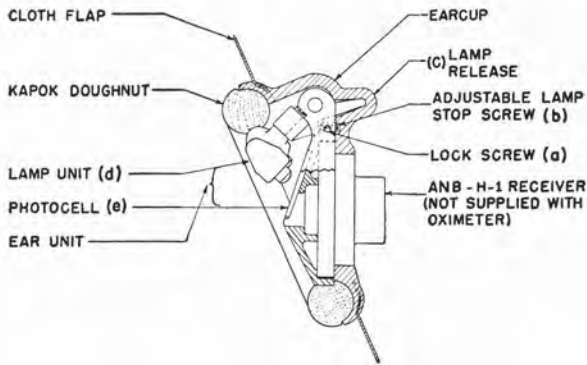

FIGURE 1. Sectional view of the ear unit.

Adjustable stops are provided so that the unit can be adjusted to the individual ear with a fixed optical path after adjustment. The ear

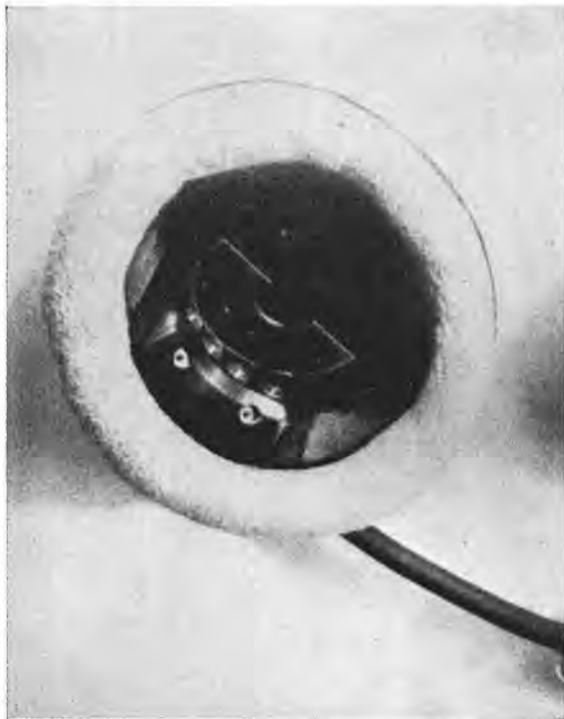

FIGURE 2. Ear cup showing lamps and photocell of the oxygen want indicator.

unit is built into a modified Harvard 5b ear-phone cup which is sewed into a standard flying helmet or mounted on a headband. Figure 1 is



FIGURE 3. Ear unit mounted on headband.

indicating unit were developed and are described below.

3.2.1 Model I—Pointer Indicator

This instrument provided indication on a standard meter face with the numbered scale replaced by three large divisions, Danger, Low, and Normal. It was necessary to use a simple photoelectric amplifier to amplify the photocurrents about 5 times so as to give full-scale deflection on the most sensitive meter movement available. A full description of this amplifier can be found elsewhere.^{5b} This instrument

3.2.2 Model II—Signal Light Indicator



FIGURE 4. Signal light type oxygen want indicator.

proved satisfactory in flight tests, but it was felt that a more striking indication was needed. Accordingly, the signal light indicator was developed.

This instrument (see Figure 4) was designed to give warning of approaching anoxia by changing the color of a signal light. Since the deflection of the microammeter by the unamplified currents was sufficient to do this, the photoelectric amplifier was not needed. A small lamp mounted inside the meter case and a system of a slit and two cylindrical lenses produce a concentrated beam of light. The light passes through a tricolor flag cemented to the meter pointer with the result that the color of the light is determined by the current flowing through the meter. A variable resistance shunting the meter is used to adjust the light to blue for 100 per cent saturation. A green light then indicates a safe oxygen concentration, and a red light a dangerous one. The narrow cone (30 degrees) of light used for adequate brightness necessitates rather careful alignment of the instrument. Another difficulty is that a light intensity which will be clearly visible during

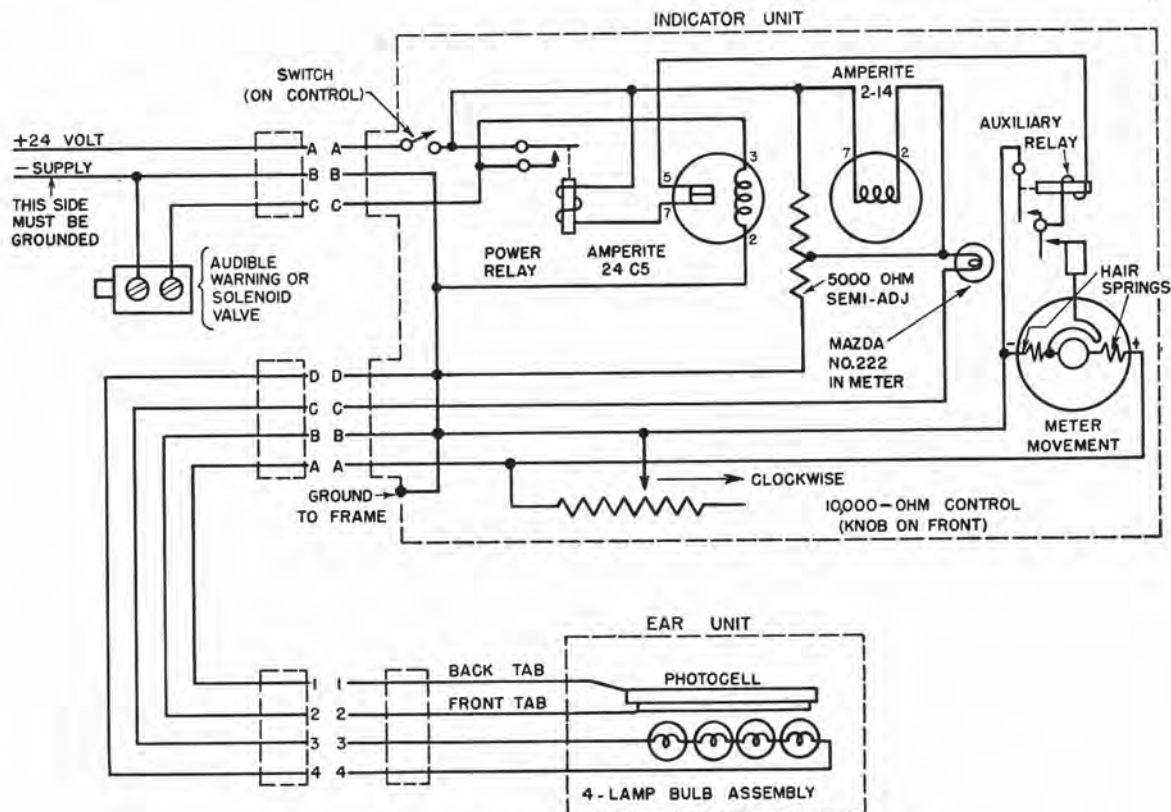

FIGURE 5. Circuit diagram of oxygen want indicator with relay.

the day becomes glaring at night. Both of these difficulties could probably be corrected, although this would require additional adjustments on the part of the flier. Fifty of these instruments were built by the Central Scientific Company and were thoroughly tested both in the laboratory and in flight and proved satisfactory.

3.2.3

Model III—Signal Light Indicator with Relay

Flying personnel who participated in the flight tests of the Model II indicator felt that the visual signal should be supplemented by an additional warning such as an audible signal and by a valve which would release a store of emergency oxygen. This necessitated the incorporation into the indicator of a sensitive relay capable of handling the current required to operate small power devices. The sensitive relay developed to do this has been fully described elsewhere.² The primary relay is the meter movement itself. An auxiliary relay, closed by the primary relay, provides an alternate path for the current and also periodically separates the contacts of the primary relay, thus avoiding the welding action which is the principal difficulty with ordinary sensitive relays. The primary and auxiliary relays in turn control a power relay. Five Model III indicators were constructed and proved satisfactory in laboratory and flight tests. Figure 5 is a circuit diagram of the Model III indicator.

3.3 FLIGHT RESEARCH OXIMETER

The flight research oximeter was to be as accurate and reliable as the laboratory model, but capable of operation in aircraft. The two-color principle had to be retained in order to achieve the necessary accuracy, but this meant that the photocurrents involved were many times smaller than those involved in the oxygen want indicator. Early attempts^{5c} at a solution involved the development of an antivibration mounting for the galvanometer and the use of electron-multiplier tubes instead of the barrier

layer cells. Neither of these proved satisfactory, and the final model is the same as the laboratory oximeter except that a d-c amplifier is used to amplify the weak currents from the photocells to the point where they can be recorded on a 0-5 milliamperemeter. The amplifier used is a commutator type of d-c amplifier built by General Motors and rebuilt so as to ensure constant gain with varying supply voltage. A complete description of the amplifier together with circuit is available elsewhere.^{5d} A 16-millimeter motion picture camera is used to photograph



FIGURE 6. Flight research oximeter. The Coleman ear unit is shown in the foreground.

the oximeter meter and other appropriate instruments such as a watch and altimeter. The spring motor of the camera is replaced by an electric one which drives the camera at such a speed that a picture is taken every 2 seconds. Figure 6 is a photograph of the amplifier and photorecorder. In addition, there is a box containing the power supply and stabilizing units (not shown). The commercially available Coleman ear unit is used with the oximeter. It may be seen in the foreground of Figure 6.

The flight research oximeter was tested against the standard laboratory oximeter by putting ear units on both ears of the same subject. In altitude chamber tests both at room temperature and in the cold, the simultaneous readings from the two instruments agreed to about 1 or 2 per cent. Flight tests of the instruments showed it to be satisfactory except for some short periods of unsteady operation.

3.4 EVALUATION AND SUMMARY

Two different types of oximeter were developed: a warning device intended for routine use in high-altitude flight, and a research instrument of higher accuracy designed for physiological research and the testing of new equipment under actual flight conditions. Four research instruments were constructed and delivered to Service laboratories. A satisfactory warning indicator was developed and 50 instruments were manufactured. The new oxygen supply systems introduced at the time of the original request proved very satisfactory with the result that the need for such a warning device was much less than anticipated. Consequently, the oxygen want indicator was not adopted for

regular use. By far the biggest disadvantage of the indicator is that it is uncomfortable. The inability of one standard shape of ear unit to fit the varying shapes of ears increases man's natural dislike of having any fixed object attached to his ear. In addition, the pull of the cables on the helmet increases the chance of accidental displacement and false indication. Much of the difficulty comes from the ear unit's being mounted on the helmet. Should the need for an oxygen want indicator as a routine instrument ever recur, it should be possible to devise a clip-on type of ear unit which would remove many of the difficulties. This, with an indicator and relay such as used in the Model III instrument, should provide a very satisfactory device for warning the flier of approaching anoxia.

Chapter 4

RADIO CHRONOMETER COMPARATOR

4.1

INTRODUCTION

THE AERIAL MAPPING of the earth's surface, as carried out by the Army Air Forces, requires the measurement of the location of certain reference points with a high degree of accuracy. This is done by celestial observations for which an accurate knowledge of the time is essential. The accuracy required is indicated

trically operated shutter which is controlled by the chronometer. The errors of personal judgment involved in timing the instant of star crossing are thus removed. It is still necessary, however, that the operator determine the absolute error of the chronometer very accurately. In order to take advantage of the accuracy of the Zenith camera, the plate measuring device, and the computation procedure, the error in timing should be no greater than 0.06 second. The observer can compare the chronometer with standard radio time signals to one second, and then by using the radio chronometer comparator measure the fractional error to 0.01 second.



FIGURE 1. Radio chronometer comparator. The left-hand side of the cabinet is the radio receiver; the comparator dial is in the lower right-hand corner.

by the fact that at the equator one second of time is roughly equivalent to 1,500 ft. The radio chronometer comparator¹ described in this report was designed to be used with the XA-2 Zenith camera² designed and built for the Army Air Forces, although it could be used equally well in connection with any of the instruments used for celestial observation.

One of the great advantages of the Zenith camera over those devices which involve the timing of star passages is that it has an elec-

4.2

DESCRIPTION

The comparator, developed and built by the Hughes Aircraft Company, is shown in Figure 1. Basically it consists of a motor rotating at one revolution per second which carries a small neon lamp behind a transparent scale which is graduated from 0 to 100 around a full circle. The lamp is flashed twice each second, once by an impulse from the chronometer, and once by an impulse from a standard time signal received on the radio receiver. The separation between the two flashes on the scale gives the fractional error of the chronometer in hundredths of a second.

The radio receiver, which is an integral part of the comparator, has to satisfy several requirements. It must be portable and capable of operating from self-contained batteries, 110-volt a-c or 110-volt d-c power. It should be capable of receiving Station WWV on one of its four frequencies (2.5, 5.0, 10.0, and 15.0 megacycles) anywhere in the world, and should also be able to receive the standard broadcast band and the 20- to 30-megacycle band. The radio receiver which had been used for time comparisons in surveying work (Hallicrafter Model S-39) satisfied the frequency range and power source requirements very well, but had a high internal

noise level which made it unable to pick up weak signals. Since no other available radio receiver fitted the requirements as well, it was decided to modify the S-39 receiver so as to increase the signal-to-noise ratio and thus obtain the desired sensitivity. This was done by replacing the S-39 antenna with a standard 13-ft whip antenna, model AN-29-C. This necessitated replacing the entire input circuit before the grid of the r-f amplifier with a new circuit. The impedance of the new antenna was calculated and new series-resonant input circuits designed which could be inductively tuned for greater sensitivity.

Two different types of motors were used to rotate the neon light. The first tried was a small 5-volt d-c motor. Coarse and fine controls were provided to adjust the voltage so as to make the speed exactly one revolution per second. This condition is obtained when the flashes from the chronometer or the time signals occur at the same point each revolution. One comparator was built using a vibrator-type d-c motor. The speed of the vibrator was found to be essentially independent of voltage and torque and showed better speed characteristics than the other. There is a problem of electrical noise

generated by the vibrator contacts which can be partially solved by using a separate battery for the motor supply. The speed can be controlled by means of a screw which effectively varies the vibrator spring stiffness.

The comparator was tested by the manufacturer by comparing a chronometer with time signals from Station WWV. It was found that comparisons to 0.01 second were possible if sufficient care were taken in synchronizing the motor speed. One model was also tested in the field by being used to time the exposures taken with a Zenith camera. The results were of the same order of accuracy as those obtained with other methods of time comparison. It was not felt that sufficient test data had been obtained to make possible definite conclusions as to the value of the comparator.^{2a}

The manufacturer feels that the comparator is correct in principle, but that a more easily synchronized motor is needed. While the modified receiver has a signal-to-noise ratio about 10 times better than the original receiver, it is still not sensitive enough. They feel that no further attempts should be made to improve the receiver, but that a completely new receiver should be built if more sensitivity is needed.

Chapter 5

FUEL QUANTITY GAUGES

5.1 INTRODUCTION AND SUMMARY

THIS REPORT deals with work done towards the development of a reliable and accurate fuel quantity gauge for use in aircraft. The information desired most by the pilot is not the volume of fuel in the tanks, but rather the cruising radius obtainable with that fuel. This cruising radius depends upon the total potential heat energy of the fuel which is very closely directly proportional to the weight of the fuel since the heat of combustion in Btu per pound varies less than 1 per cent for the entire range of aircraft fuels in use. The indication should be accurate to within ± 1 per cent of the tank capacity and should be unaffected by reasonable changes in flying attitude.

Almost all fuel gauges existing before the war measured the tank contents by means of a device responding to depth, such as a float or hydrostatic unit. The measurement of the depth at one point produces a change in indication of the gauge with a change in attitude of the plane, and, unfortunately, practical considerations usually dictate the placing of the device at some point other than the one which would make this change a minimum. The hot-wire gauge described in Section 5.4 is a depth-measuring device, depending for its operation on the difference in the thermal conductivities of the liquid and the air and vapor. It is simple in principle, and quite a bit of work was done on it, but no reliable and accurate gauge was attained. The chief difficulty is that of removing spurious effects caused by thermal gradients in the liquid.

Attempts have been made to construct a device which would actually weigh the amount of fuel in the tank,¹ but, while it is possible to construct a laboratory model of such a device, practical considerations prohibit the actual use of it in aircraft. A measurement of the volume of the fuel, while not as desirable as a measurement of the mass, would certainly be preferable to a simple measurement of the depth at one point. Accordingly, work was done on an acous-

tic device which measured the volume of *air* in the tank by measuring the coupling between a driver unit and a pickup unit mounted on the tank. This device proved unsatisfactory and was not carried beyond the experimental stage. The chief difficulty was that of removing false indications caused by external noise.

In view of the fact that a Breeze flowmeter gives a quite accurate indication of the mass rate of fluid flow, an electric frequency meter was developed which by measuring that rate could be used to measure the quantity of fuel remaining in the tank. The frequency meter proved satisfactory but was not adopted for use as a fuel quantity gauge.

The best way of getting a measurement of the mass of the fuel seems to be by means of some kind of capacitor-type fuel gauge. Such a gauge depends for its operation upon the change in capacity with fuel level of a vertical capacitor in the tank. This change occurs because of the different dielectric constants of the fuel and its vapor. An investigation was made of the properties of a number of fuels to see what effect changes in the temperature would have on the calibration. It was found that the variation was a linear one which should be susceptible to compensation fairly readily. A device was developed which made use of the change in capacity by using the capacitor as part of the tank circuit of a crystal-controlled oscillator. The crystal current, read on an r-f milliammeter, gave an accurate indication of the amount of fuel. Only a rough experimental model of this gauge was made, but it seems worthy of further development.

5.2 ELECTRIC FREQUENCY METER AND TACHOMETER

The operation of the frequency meter³ is indicated in Figure 1. When the switch *S* is in position 1, the vibrator *V*, suitably driven either mechanically or electrically by the device, the frequency of which is to be measured, alter-

nately charges condenser C_1 from battery E through contact K_1 and discharges it through contact K_2 and the shunted ammeter A . The average current then is

$$I = NEC_1,$$

where N is the frequency of the vibrator. When switch S is in position 2, the current through the shunted ammeter will be

$$I_0 = \frac{E}{R_1}$$

if R_1 is much larger than the resistance of the shunted ammeter. Eliminating E from the equations, we have

$$N = \frac{I}{I_0} \cdot \frac{1}{C_1 k_1}$$

The precision of the frequency meter then depends on the linearity of the meter and the constancy of the values of R_1 and C_1 . The variable shunt R_2 is used to set the meter to the meter of the standardizing current I_0 , thus correcting for changes in E . The condenser C_2 is used to smooth out the current at low frequencies.

In the experimental model constructed, A is a 0-50 microampere meter; and the other components are: E , 12 to 16 volts; R_1 , 250,000 ohms; R_2 , 5,000 ohms; C_1 , 0.1 microfarad; and C_2 , 500 microfarads. This gives a calibration of 1 microampere for 1 c if I_0 is set at 40 microamperes. The time constant of the discharge circuit is such that charging and discharging of condenser C_1 are essentially completed during the times that the vibrator contacts are closed.

Several types of polarized relays were used for the vibrator, but proved unsatisfactory because of the critical adjustment required. Accordingly a relay was built from a 0-200 microampere meter. Spring contact arms were fastened to the coil, and these made contact with contacts fastened to the magnet. The relay was designed so as to give a wiping effect between the contacts. This wiping tended to prevent sticking and bouncing and also cleaned the contact surfaces. This relay was found to be operated satisfactorily by the output of the Breeze flowmeter at frequencies ranging from 1 or 2 up to 50 c.

5.3

ACOUSTIC METHOD

The acoustic volume-measuring device involves applying an oscillating pressure change to the air in the tank and measuring the pressure change produced in a receiver connected to the tank. Since the amount of coupling between the driver and the pickup depends on volume of air, the output of the pickup device should be a measure of the volume of the fuel in the tank.

The first device tried⁴ used the same unit for both driver and pickup. It was unsatisfactory, being able to distinguish between a full tank and empty tank, but unable to measure intermediate volumes.

A device which used small dynamic loud-speaker units as driver and pickup proved more satisfactory. It can be shown^{4a} that the pickup voltage is

$$E = \frac{E_0}{1 - \frac{V_f}{V_t}}$$

where E_0 is the pickup voltage for the empty tank, V_f is the volume of the fuel, and V_t is the volume of the tank. In order to make the instrument more sensitive, enough voltage from the driver is supplied to the pickup to cancel the voltage when the tank is empty. The output is measured on a tuned voltmeter. The driver used about 0.1 watt of power.

This device proved more satisfactory than the one-unit device, but was not sufficiently accurate (the best accuracy achieved was about 10 per cent) and had the great disadvantage of reacting to external noise. A complete description of the device, together with suggestions for its improvement, can be found elsewhere.⁴ Because of the difficulties as to size and complexity of equipment needed to make a satisfactory acoustic gauge, further work was discontinued.

5.4

HOT-WIRE METHOD

The hot-wire gauge depends for its operation on the differing thermal conductivities of the liquid fuel and of the air and vapor above it.

If a vertical resistance wire in the fuel tank is heated in some manner, the fraction of the wire in the liquid will be cooler, with a lower resistance per unit length, than the fraction above the liquid. The resistance of the wire, then, gives a measure of the depth of the liquid. Preliminary development of the hot-wire gauge was undertaken at Johns Hopkins University^{5a} using a Wheatstone bridge arrangement, but

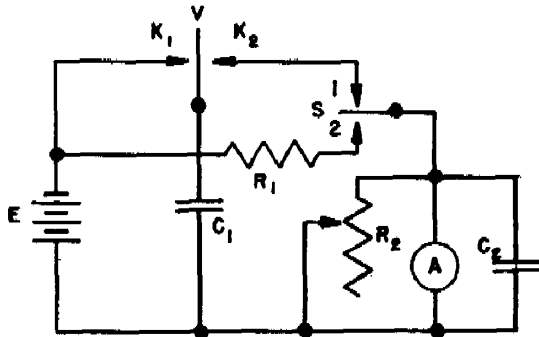

FIGURE 1. Schematic electric circuit of frequency meter.

it was found that the simple circuit used was sensitive to changes in both pressure and temperature. Further work was carried on at the laboratories of Joseph Rozek,^{5b} where a simple method was developed which would automatically compensate for changes in the thermal conductivity of the air and vapor caused by changes in either the pressure or temperature or both.

Figure 2 gives the basic electric circuit for the gauge. R_1 , R_2 , and R_3 are identical resistance wires with R_1 being wholly within the liquid, R_3 wholly above the liquid, and R_2 being the vertical wire the resistance of which changes with the depth of the liquid. A simple derivation gives the following expression for the fraction of the wire immersed in the liquid:

$$\frac{x}{L} = \frac{R_3 - R_2}{R_3 - R_1}$$

The ratio network shown in Figure 3 reduces the measurement of this ratio to the measurement of two voltages. Each of the three resistances is duplicated by an identical resistance, and the six resistances are connected as shown.

Since the two sides of the network are the same, they will carry the same current, and we have

$$\frac{e}{E} = \frac{iR_3 - iR_2}{iR_3 - iR_1} = \frac{x}{L}$$

It is assumed that the resistances of the devices used to measure e and E are very large compared to the resistances of network branches.

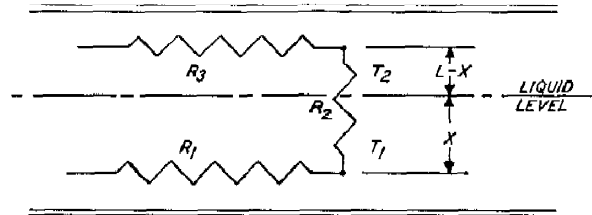

FIGURE 2. Basic circuit of hot-wire fuel gauge.

A number of different models were constructed, and a full description of them together with the results obtained may be found elsewhere.^{5b} Most of the gauges were constructed so that the network current was the heating current, although the use of separate heating wires was tried. The chief precaution to be ob-

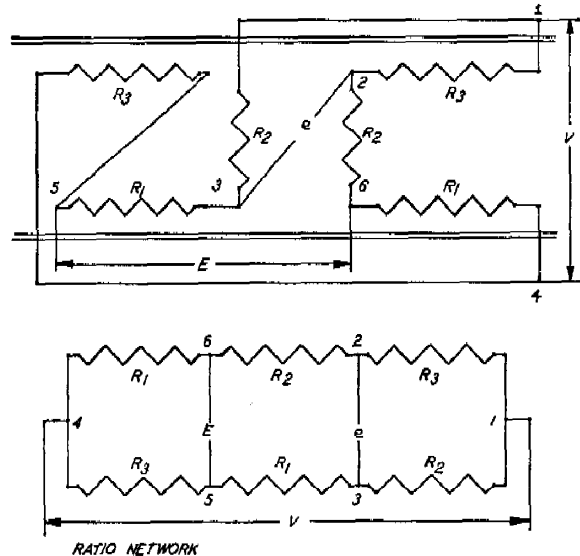

FIGURE 3. Ratio network of hot-wire fuel gauge.

served is to have the geometry of the indicating elements and the vapor compensating elements identical so as to cancel out the effects of thermal differentials. This can be done in a laboratory model, but the difficulties involved in doing it for a gauge suitable for use in air-

craft have not been solved. The extreme simplicity of this type of gauge would seem to warrant its further development. It does, however, suffer the additional difficulty of measuring the depth at one point, rather than the mass of the fuel.

5.5 CAPACITY METHODS

5.5.1 Introduction

The basic principle of operation of a capacity-type fuel gauge is the change with liquid level of the capacity of a condenser with vertical plates mounted in the fuel tank. This change occurs because the dielectric constant of the fuel is about 2, as compared with the value of 1 for the air and vapor. This principle had been applied in some British gauges,^{1,2} and some work done at the Royal Aircraft Establishment¹ indicated the feasibility of designing a condenser system, the capacity of which would give an accurate measurement of the mass of the fuel, regardless of any normal changes in attitude of the plane. The condenser systems would, of course, be different for different aircraft tanks, but this presents no particular problem. Suggested systems for several types of aircraft are given in the British report.¹ One important question is the effect of temperature upon the accuracy of such a gauge. This was investigated by the Gulf Research and Development Company,³ and the work is described in the next section.

5.5.2 Tests of Different Fuels

A simple theoretical argument^{6a} shows that the indication of a capacity gauge will be given by

$$I = \frac{AM(\Sigma - 1)}{\rho},$$

where I is the indication, M is the mass, Σ the dielectric constant, ρ the density of the fuel, and A is a constant depending on the tank and condenser geometry. The temperature dependence of the gauge indication, then, will be

determined by the temperature variation of the quantity $(\Sigma - 1)/\rho$.

Measurements were made on four different fuels: a standard commercial fuel, and three synthetic fuels blended so as to give (1) a typical fuel, (2) an aromatic-type fuel, and (3) a paraffinic-type fuel. All the fuels meet the speci-

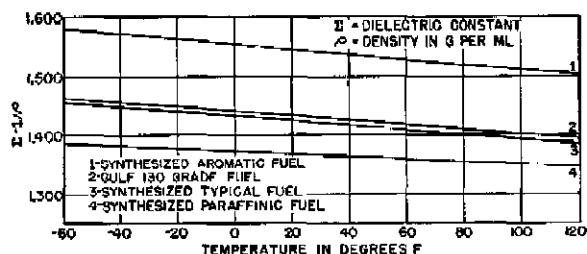

FIGURE 4. Variation of $(\Sigma - 1)/\rho$ with temperature for four aircraft engine fuels.

fications for aircraft fuels and are thought to represent the maximum range which might be encountered. The detailed specifications of the four fuels may be found elsewhere.^{6b}

The results of the investigation are given in Figure 4. Here the quantity $(\Sigma - 1)/\rho$ for the four fuels is plotted against the temperature.

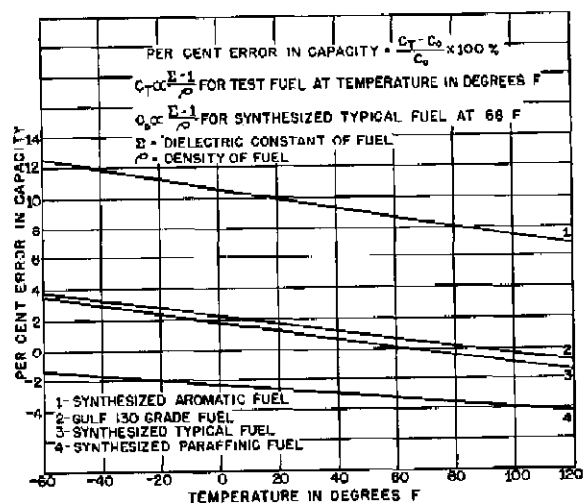

FIGURE 5. Per cent error in capacity versus temperature for four aircraft engine fuels.

Figure 5 shows the same data converted to per cent error in indication, taking the synthetic typical fuel at 68 F as correct. There are two important conclusions to be drawn. The first is that the variation between different fuels can be much larger than the temperature variation

for a single fuel. This means that some provision must be made for adjusting the gauge to a particular fuel. However, this variation is not as bad as it appears because actual fuels encountered would probably range between the commercial fuel and the synthetic typical fuel. The second conclusion is that the variation with temperature is a linear one, and as such should be susceptible of being compensated for by some fairly simple temperature-dependent electric device.

The effect of contaminants apt to be encountered was studied, and the conclusion reached was that they would not produce errors if provision was made to prevent their collecting at the bottom of the condensers.

5.5.3

Oscillator Method

A simple capacity-type gauge was constructed in which the condenser was used as part of the tank circuit of a crystal-controlled oscillator.^{5c} The indication was the crystal current as read on a hot-wire milliammeter. The electric circuit of this gauge is shown in Figure 6. The condenser is a brass tube with a central brass cylinder and is inductively connected to the plate circuit to eliminate any d-c voltages in the fuel tank. The laboratory model of this gauge proved quite satisfactory except that a stabilized plate supply is necessary. It is, however, very similar to the British Waymouth

gauge¹ and would suffer from the same disadvantages. These are difficulties with radio interference and the effect of the capacity of the

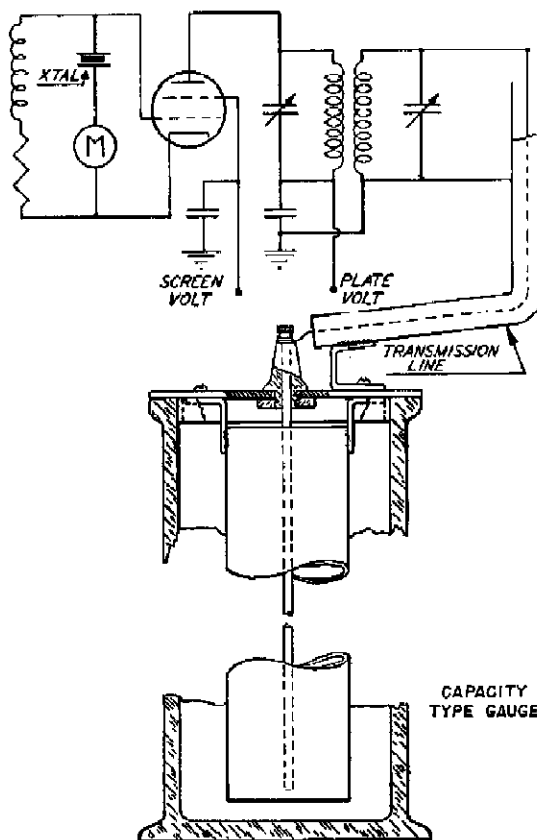

FIGURE 6. Circuit diagram of oscillator-type capacity gauge.

connecting cable. The latter makes it necessary to calibrate for each location, or length of cable, and increases the variation with temperature.

Chapter 6

COMBUSTION EFFICIENCY INDICATOR FOR NAVAL VESSELS

By F. L. Yost^a

6.1

INTRODUCTION

ON BOARD SHIP, the fireman's first task is to maintain steam pressure at the predetermined value at which the turbines are designed to operate most efficiently. The second task is to generate steam in the most efficient manner without betraying the position of the ship by smoke or haze. It is generally conceded that the most efficient combustion at a given oil-burning rate occurs when a slight haze or light wisps of brown smoke leave the top of the stack. This operating condition, known as "trace smoke," is not permissible aboard ship; therefore, sufficient air must be used for combustion so that smoke or haze is just eliminated. When there is insufficient air black smoke results, and when excessive quantities of air are used a white smoke results. Operation must occur between these limits. The overall boiler efficiency at white smoke, however, may be as much as 10 per cent less than it is at a trace of brown smoke, the condition for optimum combustion.

The proper procedure for adjusting the air rate to give the most efficient permissible combustion after lighting off a burner is to decrease the air pressure gradually and to observe the stack through a fireroom periscope until a slight haze can be distinguished by an experienced observer. When the haze appears, the air pressure is increased by a tenth of an inch of water, or less, to just eliminate the haze. Such adjustment cannot be made rapidly since sufficient time must be allowed between each change in air pressure to permit the furnace to respond. Since the criterion of operation is "no smoke," it is easy to play safe and use ample air, particularly if the oil pressure is varied from time to time to maintain steam pressure.

The appearance of a trace smoke as an indication of the proper air pressure for most efficient combustion is not a guarantee that the greatest efficiency is being realized. There are

^a Technical Aide, Division 17, NDRC.

a number of factors which affect the efficiency of combustion before a trace smoke appears. The most satisfactory and practical single measurement which can be made to determine combustion efficiency is flue gas analysis for carbon dioxide. This was believed to be true prior to the study reported here and was one of the conclusions of this study. Prior to this work, the Navy had adopted a *Ranarex carbon dioxide recorder* [RR] but difficulties (see Section 6.4.2) connected with it caused it to be abandoned.

In the early days of Section D-3 of NDRC, it was proposed that a project be set up to investigate the feasibility of providing an acceptable combustion efficiency indicator for naval boilers. It was hoped that, by a careful control of boiler efficiencies, a fuel saving of as much as 6 per cent might be effected, and the cruising radii of ships might thereby be increased.

6.2

MILITARY REQUIREMENTS

The basic military requirement in the development of a device was that it indicate fairly accurately the efficiency of combustion in a naval oil-fired boiler. There were other requirements which were desirable. The instrument should be simple. It should have a large indicating dial. It should have practically no lag in following changes in firing conditions. There were still other requirements which were necessary from a practical viewpoint. The apparatus should require very infrequent attention to maintain it in operation. Any necessary servicing should be of such nature that it could be performed by enlisted personnel.

6.3

SUMMARY OF DEVELOPMENT

The work on this project, which proceeded along a number of different lines,¹⁸ was done by

the Towne Scientific School of the University of Pennsylvania.

Through the cooperation of an oil-burning school established at the Naval Boiler and Turbine Laboratory of the United States Navy Yard, Philadelphia, Pennsylvania, it was possible to observe shipboard fireroom practice. The personnel of this project spent several weeks observing demonstrations of the recommended manner of firing boilers, which made it possible to learn some of the numerous factors which affect combustion efficiency. In certain cases, it was possible to make experimental measurements to determine the magnitude of the effect of these factors. Some of the conclusions reached in this study are given in Section 6.4. The main value of this investigation was that it gave a necessary background of information concerning standard practice in boiler firing—a fund of information which could not have been obtained in any other way.

Early in this investigation, it was learned that the Naval Research Laboratory had done some work which seemed to indicate that flame brightness might serve as a measure of combustion efficiency. This work was reviewed, and additional tests were run.^{8a} It was concluded that flame brightness was not a suitable indication of combustion efficiency.

Since it had been thought all along that analysis of the flue gases for carbon dioxide would give the best indication of combustion efficiency, three commercially available types of carbon dioxide indicator were tested,^{8b} each working on a different principle. The type which most nearly met the requirements was determined, and methods were suggested for increasing its suitability for naval use.^{8c} These alterations would not have increased the simplicity of the instrument, nor would they have lowered the amount of attention it required. A general conclusion of this study was that, since boiler efficiency depends on a number of factors, some independent and some interdependent, it is reasonably safe to say that no rugged simple indicator of combustion efficiency can be devised depending on the measurement of a single parameter.

It does seem that the firing of naval boilers should be under instrument control to assure maximal efficiency combined with freedom from

smoke dangers. The instruments which could be devised for this purpose are necessarily complex and involve the measurement of more than one variable so that the attention of an engineer officer is necessary. The vital importance of boiler efficiency in the operation of naval vessels seems to justify fully the employment of skilled technical officer supervision.

6.4 DESCRIPTION AND TECHNICAL INFORMATION

6.4.1 Study of Firing Technique

The results of observations at the Naval Boiler and Turbine Laboratory may be summarized as follows.

1. Several of the numerous factors affecting combustion efficiency can be eliminated as operating variables by properly adjusting them and holding them constant. Among these are fuel oil viscosity and fuel oil quality.

2. Other variables limit the maximum combustion efficiency which can be realized under a given rate of generating steam. There is little variation practical for these factors which include sprayer plate size, type of nozzle, fuel oil pressure, and number of burners in operation.

3. There are several factors which, at a given steaming rate, can be varied by the fireman to improve or change the combustion efficiency of the burner. Among these are register opening, burner withdrawal, and air pressure. The first two are usually set for an atomizer of given size. For maximum efficiency, the air pressure should be held to a minimum without generating smoke. It is in this respect that the greatest improvement can be made.

4. Complete automatic control of boiler firing would eliminate the need for a combustion efficiency indicator except as a check upon the successful operation of the automatic control instruments.

6.4.2 Carbon Dioxide Recorders

Analysis of flue gases for carbon dioxide gives the best indication of combustion effi-

ciency, even though this method has its drawbacks. A fixed value for the percentage of carbon dioxide cannot be specified as a criterion of maximal combustion efficiency since other factors, such as steaming rate, limit the maximum percentage which can be obtained in the flue gases without obtaining smoke. Flue gas analysis varies with the fuel or oil being used. Furthermore, flue gas analysis does not indicate what is happening at the burner until the combustion products reach the point where a sample is being taken. Thus, before an indication occurs, there is a lag equal to the time required for the combustion products to travel through the furnace. It would be preferable to have an indicator respond when a valve is turned or an air register is opened.

Although its limitations are clearly recognized, no better practical method of measuring combustion efficiency has been found than flue gas analysis. Accordingly, considerable time was spent in studying devices which could be used for this purpose.⁸ As stated in Section 6.3, three commercial carbon dioxide recorders were installed and tested on a horizontal return-tube boiler. They were (1) a *Leeds and Northrup recorder* [LNR], a thermal conductivity or electrical type; (2) a *Hays recorder* [HR], an automatic orsat or chemical type; and (3) a *Ranax recorder* [RR], a mechanical type. (An orsat is a portable gas analysis apparatus which consists of a measuring buret and three or four gas absorption pipets connected to a manifold.) Photographs of the test installations have been published.⁸

The LNR uses the thermal conductivity of the flue gas to give the carbon dioxide content of the gas. This conductivity is measured by means of a calibrated electric resistance with a large thermal coefficient of resistance. The recorder and flue gas analyzer assembly consists of a sampling device and lines bringing the flue gas to the analyzing cell which is mounted as near to the sampling point as possible. The sample is drawn into the apparatus by an aspirator operated by water or compressed air. The analysis is transmitted electrically to a micromax indicator and recorder.

The HR is a mechanical form of hand orsat used for flue gas analysis. The pumping action

of water is used to pass a measured quantity of gas over caustic solution. A pneumatic device transmits the flue gas analysis to a chart. The HR operates intermittently. Samples are taken about every 2 minutes, although flue gas is continuously aspirated through the instrument, bypassing the analyzing section when an analysis is in progress. The instrument consists of two parts: an analyzing cell near the point of sampling and a recorder located within easy sight of the fireman.

The RR is mechanical in nature. Two motor-driven fans blow separate streams of air and flue gas against two other fans which are coupled in such a way that the difference in the torques on the two receiving fans can be observed. This difference in the torques is proportional to the difference in gas densities which, in turn, is proportional to the gas compositions.

Both the LNR and HR were difficult to calibrate, but, once calibrated, they retained the calibration very well. The RR was easier to calibrate, but needed frequent recalibration. The RR had the shortest response time. The LNR had the longest response time, which was between 2 and 3 minutes.

The reliabilities of the instruments were determined daily by comparison with an orsat analysis.⁸ Since the original calibration of each instrument was subject to an unknown error, the average of all daily deviations was taken to be the calibration error. The residuals, defined as deviation minus mean deviation, were considered to be a measure of the accuracy of the instrument. The reliability was defined as the average deviation of a single observation from the corrected mean.

The calibration error of the HR was found to be -0.5 per cent CO_2 , and its reliability ± 0.34 per cent CO_2 . The calibration error for the LNR was -0.3 per cent, and its reliability was ± 0.44 per cent. The calibration error for the RR canceled out statistically over a period of time (possibly caused by the frequent calibrations necessary), and its reliability was only ± 0.96 per cent.

Many of the features of all three of these recorders are mechanical in nature and require the usual maintenance of oiling, greasing, cleaning, and similar care. Maintenance peculiar to

carbon dioxide recorders is the cleaning of stack filters every few months and weekly replacement or cleaning of secondary filters. In addition, the LNR saturating chamber must be refilled once or twice a week. The thermal-conductivity cell requires periodic cleaning every three or six months, depending on the cleanness of the flue gas. In the HR, caustic solution must be replaced every six months while the "tattler jar" must be refilled with water every two or three days. Certain hard-rubber capillaries should be cleaned every month or two. The RR saturating chambers require filling once a week. A daily zero check is also necessary. The internal mechanism, including such parts as fans and fan shafts, requires complete cleaning once or twice a year.

The LNR is a complicated electric instrument with a sensitive galvanometer. The analyzing cell is made of glass and is consequently fragile. Servicing the LNR requires the aid of a qualified instrument man. The HR requires a large quantity of water for its operation. A level mounting is essential for accurate analysis. Caustic solution in the hands of careless or inexperienced men might be dangerous. The RR is rugged and compact. It reads only in a level vertical position. Being mechanical in principle, it can be serviced by an intelligent or experienced mechanic.

Because of special considerations involved in the naval application of a carbon dioxide recorder, such as speed of response, compactness and simplicity, pitch and roll of a ship, vibration and shock, maintenance and servicing, and reliability, it was decided that the RR was the most promising.

In its available form, the RR has a number of undesirable features. Insufficient power is developed by the measuring device to position an indicator and recorder. The belt drive on the pulleys of both fans may slip so that both fans may not have the same speed of revolution. The bearing for the shaft of the impulse fan permits a cantilever action which may affect the freedom of rotation of the fan. There is no guarantee that the flue gas and air are at the same temperature, pressure, and moisture content conditions essential for proper operation. There is no provision to discharge water from saturat-

ing chambers which in time may become strongly acidic. There are no sight glasses to indicate when the water levels in saturating chambers are getting low.

Auxiliary apparatus was designed for the RR to give the desired heat transfer between flue gas and air and to insure saturation of both air and flue gas. Tests showed that a slight difference in pressure could still exist between the air and flue gas. It was finally decided that the auxiliary apparatus was not suitable for naval use. Several features of the RR which might be modified for better results are:

1. A positive drive for both impeller fans to insure constant and equal speed would be desirable. This could be accomplished by mounting the fans on the same shaft, by using a chain drive, or by using two synchronous motors.

2. A more powerful fan-motor system could be used to draw larger gas quantities for test and thus to reduce the time of response.

3. The usual indicator and recorder system could be replaced with an auxiliary unit by means of which the small differential torque developed by the impulse fans could be used to transmit the reading to a more powerful indicating and recording system. This would free the analyzing system of a drag which may contribute to its inaccuracies.

4. The design of the bearing and shaft arrangement in the instrument might be improved.

As far as carbon dioxide recorders were concerned, this project made the above comparison of three commercially available types and suggested improvements which might be made on the one which appeared most suitable for naval use. No new instrument for measuring combustion efficiency aboard naval vessels was developed. It was believed, however, that, if the RR were rebuilt as suggested above, an instrument acceptable to the Navy might be produced. It was believed also that further work should be conducted along the lines of these studies. Modern engineering science can certainly produce instrument controls for oil-fired boilers capable of maintaining an operating efficiency superior to that achieved through rule-of-thumb methods depending on prejudices and opinions of naval enlisted personnel.

6.4.3 Flame Brightness as a Test of Combustion Efficiency

Data taken by the Naval Research Laboratory, in the course of unrelated work, showed that flame brightness went through a maximum close to optimum firing condition for each firing rate. Maximum brightness occurred further in the region of smoke at the higher firing rates. The brightness peak varied with firing rate and was not very marked at the lowest firing rate.

The original work was done with a MacBeth illuminator, but flickering flame made it extremely difficult to make readings. Measurements were repeated with a General Electric exposure meter protected with a water filter.

Two sets of readings were taken at varying conditions of excess air to obtain a qualitative indication of the relation between flame brightness and excess air. A third set of readings was taken with simultaneous determinations of carbon dioxide in the flue gas. There was no perceptible maximum of brightness up to the point of trace smoke. It was concluded that, while this method had originally looked very promising, it was unsuitable for use.

6.4.4 Steam Flow-Oil Flow as an Indication of Combustion Efficiency

The overall purpose of boiler operation is to generate steam at a predetermined temperature and pressure. Accordingly, the overall efficiency of the installation is measured by the pounds of steam generated per pound of oil. It was therefore thought that measurement of this ratio might be used to indicate overall efficiency. The complete data for 11 different boilers tested by the Naval Turbine and Boiler Laboratory in the period from February 1937 to October 1941 were examined, calculated, and plotted to determine whether a general correlation of steam flow and oil flow was possible. Examination of the curves showed no general correlation. An instrument employing this principle would have to be calibrated for every type of boiler on which it was to be used, the calibration to be based on test data obtained at the Naval Turbine and Boiler Laboratory. When this work was being done, 50 per cent of the boilers in use had not been tested at that laboratory. There were, in addition, other difficulties which would have been associated with such a method.

PART II
SOUND TRANSMISSION AND INSTRUMENTATION



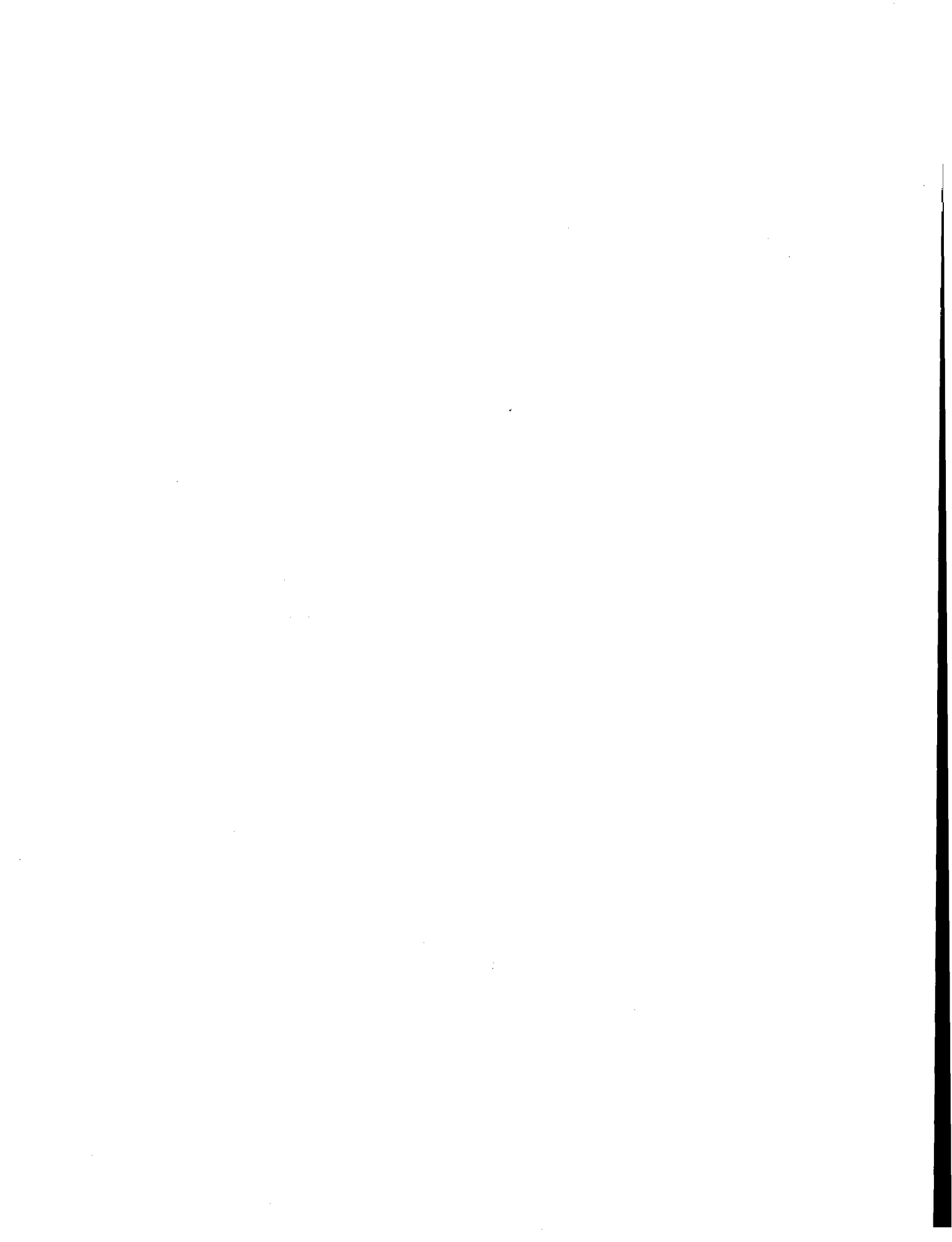

Chapter 7

ULTRASONIC SIGNALING

By Harold K. Schilling

7.1

INTRODUCTION

THIS PROJECT was established to investigate the possibilities of ultrasonic signaling and communication. For temperate zone conditions, the investigation was conducted at State College, Pennsylvania,¹ in the spring of 1944, both in open country and in forests. Later, an expedition of six men from the Penn State College project studied the effects of tropical conditions in Panama^{2,3} for approximately two months during the rainy season.

While in Panama, the Penn State College group was closely associated with a similar expedition from Rutgers University which was investigating various aspects of audible jungle noises (see Chapter 8). Obviously, both projects had one common factor, namely, the detection of the aerial vibrations that existed under various conditions in jungle terrain. In one case, however, interest was focused on the inaudible region of the sound spectrum, while in the other it was the audible region that was of primary interest. It was inevitable, therefore, that the two expeditions should collaborate and profit by the mutual assistance received on problems of common interest.

The researches on ultrasonic signaling proceeded along two lines: (1) the design and construction of suitable equipment, and (2) the determination of the possible range and reliability of ultrasonic signaling under various conditions of weather and terrain, with special emphasis upon jungle conditions in the tropics.

7.2

EQUIPMENT

SOURCES

Only whistles were used as sources because from the viewpoint of size, weight, and simplicity of operation they seemed most suitable for use by the Army, as well as for research purposes, in dense tropical jungles.

An empirical study¹ was carried out to discover (1) what determines the intensity and frequency of their output, (2) what determines their suitability for mouthblowing, (3) what methods of actuating them might be useful under field conditions, and (4) how to minimize or eliminate their audible hiss and transients. The resulting information has led to the improvement of old whistles and the development of two new kinds.³

The highest signal intensity level attained by a *mouthblown whistle* was 110 db at a distance of 1 ft. This required an airflow of 500 cu cm per sec. The output was about 0.1 watt, the efficiency approximately 5 per cent. Using air from high pressure tanks, the corresponding figures are 130 db at 1 ft, 4,000 cu cm per sec, 10 watts, 3 per cent.

RECEIVERS

No attempt was made to design small receivers suitable for use by the individual soldier, that task having been assigned elsewhere. Rather, the object was to produce research equipment which could detect signals at the greatest possible distance and maintain its operating characteristics under the most unfavorable field conditions.

Five portable, sharply selective receivers were built, covering the frequency range from 7 to 30 kc. All employed Western Electric 640-A condenser microphones. Four had resistance-coupled amplifiers, and one a heterodyne circuit. Between 17 and 27 kc all were capable of measuring intensity levels from 25 to 35 db up to approximately 140 db above 10⁻¹⁶ watts per sq cm.

Auxiliary apparatus included special test instruments used in the field in checking calibrations and locating troubles.

PARABOLIC REFLECTORS

The effectiveness of using parabolic reflectors of various diameters up to 12 in. in conjunction

with both sources and receivers was investigated. In unforested regions, the largest made available about 40 more db and in forests about 15 db. The resulting increase of directionality was not large enough to be a handicap in signaling.

METEOROLOGICAL AND MICROMETEOROLOGICAL EQUIPMENT³

For large-scale meteorological measurements standard instruments were used. For micrometeorological measurements the following special portable apparatus was built: (1) four sensitive resistance thermometers using nickel wires 0.0005 in. in diameter, (2) four sensitive hot-wire anemometers using platinum wires 0.0004 in. in diameter, (3) two direct-reading temperature-difference meters, (4) two direct-reading velocity-difference meters, and (5) auxiliary equipment, such as portable and collapsible masts.

TROPIC PROOFING³

All equipment was carefully tropic proofed. This and special precautions taken in the field and at headquarters were sufficient to prevent any failure of apparatus due to adverse tropical conditions.

7.3 TRANSMISSION MEASUREMENTS

Transmission studies were of two types: (1) direct measurements of signaling ranges, and (2) investigations of propagation phenomena and related factors determining or affecting ranges.

RANGE MEASUREMENTS

Signaling distances were measured for different frequencies, over many types of terrain, at various heights above the ground, in open country as well as in forests of different densities, under different weather conditions, at various times of day and night, both in the temperate and tropic zones.

These measurements revealed that for a given terrain there is no single value of the signaling range. Thus one might one day be able to signal 400 ft, and on another find it impossible to signal more than half that far—at the

same place and with the same apparatus. Also, ranges often vary greatly in length within short time intervals. Though the intensity at the source may be constant, the received signal frequently fluctuates in intensity as much as 20 db within a few minutes, or even seconds. Consequently, near the end of a range signals often fade out and reappear quite unpredictably.

The experimental procedure was to determine the absolute intensity level first 1 ft from the source and then at increasingly larger distances until the signal could no longer be de-

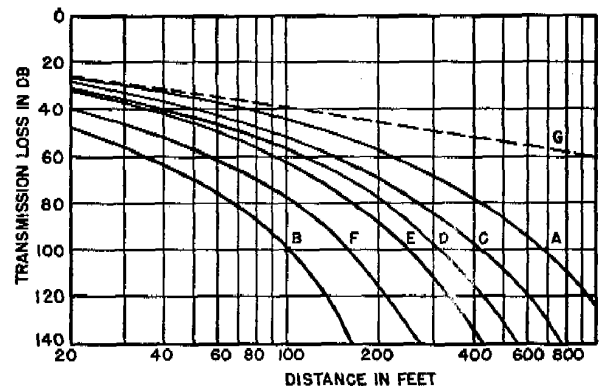

FIGURE 1. Transmission curves for unforested areas, 17 kc.

tected. The transmission losses in decibels were then computed and plotted, as negative ordinates, against the corresponding distances, as abscissas, on semilog paper.

Typical transmission curves obtained in that manner for unforested areas are depicted in Figure 1. Obviously, a maximum signaling distance depends upon two factors: (1) the characteristics of the apparatus, and (2) the properties and condition of the propagating medium. Thus, the equipment limits the number of decibels one can "work with," while the medium determines the distance within which that much loss occurs. A transmission curve depicts the latter.

Such considerations have suggested the use of the term "*n* db range" to denote the distance within which a signal suffers a transmission loss of *n* decibels relative to its intensity at 1 ft from the source. Thus, when curve A (Figure 1) was obtained, a 60 db range was 210 ft, and an 80 db range was 410 ft.

Figure 1 may be regarded as representing the overall possibilities of signaling for the particu-

lar frequency of 17.5 kc in open country. Curves *A* and *B* show respectively the most and the least that can be expected. Thus apparatus capable of handling a transmission loss of 100 db should under the worst conditions yield a range

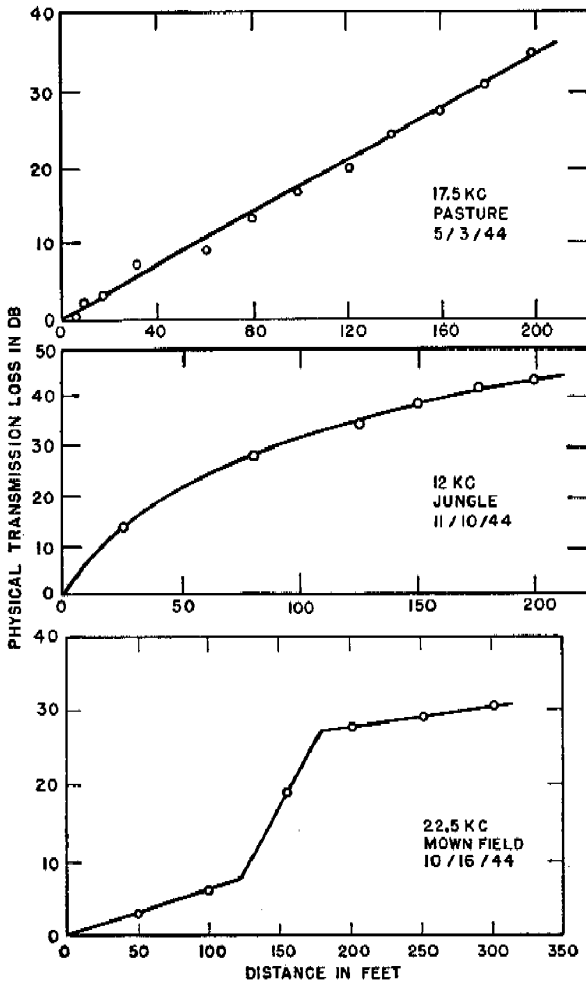

FIGURE 2. Δ curves: (top) straight, typical of open air with absorption but without scattering; (middle) curved, as in jungles or in air which is both absorbing and scattering; (bottom) broken, indicating "zone of silence."

of at least 98 ft and at most 710 ft. The area between curves *A* and *C* represents the spread of ranges in Panama when both source and receiver were 3 to 5 ft above the ground. Region *A* to *D* indicates the spread in Pennsylvania for the same heights. Curves *D*, *E*, *F*, and *B* respectively depict the practical lower limits for ranges at the heights of 60, 30, 10, and 3 in., while curve *A* indicates the upper limit for all heights.

It is impossible to speak of typical transmission curves for jungles in general. Not only is the rate of attenuation different for jungles of different densities, but also that rate changes with distance in various ways. It can be said, however, that in only few jungles would the ranges be as long as those indicated by curve *C*, and in many the ranges are less than half as long as those given by curve *B*.

STUDY OF TRANSMISSION PHENOMENA

In open unforested areas, when there are no large-scale temperature or wind gradients, the variation of signal intensity with distance can usually be explained simply in terms of the inverse square law (a whistle being essentially a point source) and a negative exponential law (the air having an absorption coefficient for ultrasonic energy).

This is indicated by the rectilinearity of so-called Δ curves,³ illustrated by curve *A*, Figure 2. Such a curve is obtained by subtracting the transmission losses due to divergence (given by the dashed line *G* in Figure 1) from the total transmission losses (depicted by transmission curves such as *A*, *B*, etc., in Figure 1) and then plotting the difference in decibels (that difference being due to the medium and terrain and therefore referred to in the figure as physical transmission loss) against distance on rectangular coordinate paper.

The slope of such a derived Δ curve, when it is rectilinear, equals the absorption coefficient of the air in decibels per foot. The values of the coefficients obtained in this manner are consistent with those obtained by other workers by other methods.

In a forest a Δ curve is always bent (see curve *B*, Figure 2), i.e., has one or more "knees" in it. This is due to scattering in the medium, say, by leaves or branches. A theory of absorbing scattering media has been developed which rather successfully explains such Δ curves and yields a method of computing separate effects of scattering and absorption.

At times the air itself (at locations where there are no "foreign" solid bodies, such as leaves) is a scattering as well as absorbing medium. Here again, when correction is made for scattering, the absorption coefficients ob-

tained are consistent with values obtained by others.

When there are large-scale temperature lapses or opposing winds the A curves are broken, i.e., have discontinuities as illustrated by curve C, Figure 2. These are due to the presence of zones of silence in which the rate of attenuation is different from that obtained outside such regions. The appearance, evolution, and disappearance of such zones have repeatedly been observed both acoustically and micrometeorologically through complete 24-hour periods.³

Three types of intensity fluctuations, two of them periodic and one random, have been recognized and correlated with related micrometeorological phenomena.

DIFFRACTION

The possibility of ultrasonic signaling around obstacles is of considerable importance from the military point of view. Thus, if because of sharp acoustic shadows it were impossible to signal to points in back of large trees, or over barricades, or into trenches, the usefulness of such signaling would be greatly impaired.

Simple diffraction theory suggests that for waves 1 or 2 cm in length most bodies of ordinary size should cast rather sharp shadows. On the other hand, in many practical situations, conditions are such that simple theory does not seem entirely applicable.

Experimental investigation³ shows that: (1) in typical jungles, intense ultrasonic shadows are almost nonexistent for frequencies near 20 kc; (2) in the open, when larger distances are involved, obstacles present no serious difficulty. Thus, in the open country, signaling over a distance of several hundred feet would often be about as effective whether a 5 ft or 6 ft high wall were halfway between source and receiver or not. In such cases, favorable gradients are helpful. (3) For short-range signaling in the open, simple theory predicts fairly well what may be expected.

7.4

AMBIENT NOISE

The intensity and spectral distribution of outdoor background noise, both in the audible

and ultrasonic frequency ranges, and the diurnal cyclic variation of such noise were measured in Panama³ at many locations. The jungles of Panama during the rainy season were found to be no noisier than the forests of Pennsylvania during the summer and early fall.

7.5

SUMMARY OF RESULTS AND CONCLUSIONS

1. Ultrasonic signaling is feasible over relatively short distances only. The absorption in the air is so great as to preclude the possibility of materially increasing the longest ranges reported herein through improvement of sources or receivers.

2. Experience suggests that it should be possible to develop small, portable equipment, including mouthblown whistles and receivers weighing not more than 3 or 4 lb, capable of signaling over 90 db ranges.

3. In open country, without obstructions, 90 db ranges at approximately 20 kc are rarely longer than 500 ft.

4. In jungles 90 db ranges are never longer than 300 ft. In an average Panamanian jungle a 90 db range is approximately 200 ft. In thick underbrush such a range is not more than 75 ft. In dense tropical grass it is still less.

5. Ranges decrease with increasing frequency. For the frequency of 29 kc ranges are approximately 40 per cent shorter than those for 20 kc.

6. *In open country* ranges usually increase rapidly with increasing height above the ground up to 4 or 5 ft and then only slightly up to 10 ft. For some weather conditions ranges 3 in. from the ground may be less than 25 per cent of those at 5 ft. Only under exceptional conditions are ranges nearly independent of height.

7. *In forests* ranges are much less dependent upon height. In dense jungles ranges are essentially independent of height.

8. Weather conditions most favorable to steady and long-range signaling are: (1) no wind, (2) absence of vertical temperature lapses, and (3) cloudiness and rain. Usually conditions are much more steady and uniform in forests than out in the open. Ordinarily, nighttime is more favorable than daytime.

9. The ultrasonic picture in Panama is much like that in Pennsylvania. Similar ranges were obtained. The main difference is that in Panama weather conditions and therefore signal transmission are more uniform. Thus, in the rainy season, the temperature almost always lies between 70 F and 85 F, and the relative humidity between 70 per cent and 100 per cent. The absolute humidity remains essentially constant.

Only rarely does the wind velocity exceed 7 mph.

10. In practical outdoor situations, particularly in the jungles, signaling around obstacles is frequently less difficult than might be anticipated from simple diffraction theory.

11. Ambient noise was not a serious problem for ultrasonic signaling either in Pennsylvania or Panama.

Chapter 8

JUNGLE ACOUSTICS

By Carl F. Eyring

8.1

INTRODUCTION

THIS REPORT is a summary of the work undertaken by Rutgers University under Contract OEMsr-1335 with OSRD. A nine-man expedition conducted the field work in the Canal Zone as Project SC-105 under the general supervision of the Signal Officer, Panama Canal Department. Throughout the course of the investigations close cooperation was maintained among the project personnel, the Army, and a similar expedition from Penn State College.

The present project was undertaken for the purpose of investigating the types, magnitudes, and variations of noises which are indigenous to different kinds of jungle terrain under different conditions of temperature, humidity, and wind velocity. The problems encountered on this project were somewhat similar to those arising in the project on ultrasonic signaling (see Chapter 7) except that in this case, the investigation concerned itself mainly with the detection of audible aerial vibrations.

Within a jungle, even more than in open terrain, information gained through hearing may be more important than that gained through sight. Two practical questions arise: (1) how quiet must a person be in order not to be detected by the enemy, who is known to be at a given location, and (2) how far away and in what direction is the enemy when certain recognized sounds are heard with a given loudness?

A sound will be heard if it is loud enough at the source so that, after it has traveled over the terrain in question, it still has strength enough to compete successfully with the other sounds surrounding the listener. Obviously this is an oversimplified statement of the situation, but the statement does bring out the need of knowing:

1. The sound spectrograms of Army equipment, such as guns and vehicles;
2. The sound transmission loss for the audible frequencies over various types of terrain;

3. The sound spectrograms of characteristic ambient noise.

Problem 1, the sound spectrograms of certain Army equipment, machine guns,¹ and Army vehicles,² has already been solved. Problems 2 and 3 were investigated under this project and the results obtained, together with the application of jungle acoustics to tactical problems and a consideration of micrometeorology in the tropics, form the substance of this report.

Area of Operation. All measurements were made within 50 miles of headquarters, Fort Clayton, Canal Zone. Except for a few areas, all investigations were made in terrain northward of Summit and, therefore, on the Atlantic slope.³

Three 1½-ton trucks, a command car, and a jeep, furnished with drivers by the 10th Signal Company, served to transport equipment and personnel.

The Jungle. Most jungle areas⁴ investigated were in the Atlantic zone where "the high precipitation produces a luxuriance of vegetation never equaled on the Pacific slope." For over 400 years Panama has been dominated by Europeans, and comparatively little virgin vegetation remains, this being true especially of the areas accessible by roads. Yet in spite of these facts certain areas, such as those chosen for study, have had time to take on an approximate virgin forest aspect and are as typical of such a forest as the terrain on Barro Colorado Island, the "Canal Zone Biological Area."

8.2

TRANSMISSION LOSS MEASUREMENTS

8.2.1

Apparatus and Method

Sound Apparatus. Sounds of octave band width, essentially "filtered noise" resulting from passing through a filter set the amplified

output of a bank of direct-current-carrying carbon resistors, were produced by loudspeakers placed at convenient positions in a more or less flat terrain. Microphones—no fewer than two, often as many as four—were located usually 100 ft or more apart, on a straight line, the axis of the speakers. By the use of an electric circuit terminating in a power level recorder, the intensity levels of the sound at each microphone were recorded in turn. A comparison of these levels gave the drop in sound intensity level between microphone stations.^{3a}

Meteorological Equipment. Outdoor acoustics must always include the meteorology of the terrain. Continuous records, one of temperature and another of wind velocity, were obtained by



FIGURE 1. Meteorological equipment in field.

placing thermistors^{3b} in one arm of properly designed and calibrated bridges and recording (Figure 9) on Esterline-Angus meters the unbalance introduced when the thermistors changed in resistance, in one case, because of an atmospheric temperature shift when operated cold (thermometer) and, in the other case, because of a wind velocity fluctuation when operated hot (anemometer). Relative humidity was measured by the use of a recording hair hygrometer which was always checked against a sling psychrometer.

With few exceptions, readings were made at 2 and 6 in., at 2, 5, and 10 ft, and at other selected elevations determined by the conditions at hand. The same heights were used for tem-

perature as for wind velocity measurements; for the trip up as for the trip down. The different elevations were reached by attaching a pulley to lance poles, to a limb of a tree in the jungle, or to captive balloons, and passing over this pulley a cord which was attached to the thermistor housing (Figure 1).

Care of Apparatus in Tropics. Because of moisture and fungi, it is difficult to keep electrical equipment in good working condition in the tropics. Great care was taken to store all the smaller pieces of equipment in drying cabinets, and to keep an electric light burning within the larger equipment, such as loudspeakers, when not in use. Not a single failure came because of the action of fungi, and moisture, the result of rain and dew, played only a delaying action.

8.2.2

Definitions

Transmission Loss (L). Transmission loss, measured in decibels, means the drop in sound intensity level, for whatever cause, as sound travels from one designated location to another, the nearer distance from the sound source being X_1 , the farther, X_2 .

Terrain Loss (A). Terrain loss, measured in decibels, between any two specified distances from the sound source is the transmission loss between these points less that caused by the geometrical divergence of the sound beam. It is, therefore, a quantity which, when measured over unit distances, can be attached to a given terrain, that is, a quantity which is determined by the nature of the ground covering, including the condition of the ambient atmosphere.

Terrain Loss Coefficient (α). The terrain loss coefficient, measured in decibels per foot, is defined by the relation:

$$\alpha = \frac{\Delta A}{\Delta X},$$

where ΔA is the terrain loss through a very short distance ΔX . Thus α is surely a function of the terrain (including kind of covering and condition of atmosphere), but it was not found to be a function of the distance, X , from the

sound source. Thus, since A increases linearly with distance between X_1 and X_2 ,

$$\alpha = \frac{A}{X_2 - X_1},$$

and the transmission loss between X_1 and X_2 may be written as

$$L = 20 \log \frac{X_2}{X_1} + \alpha(X_2 - X_1).$$

Profiles. A temperature profile is a plot of temperature in degrees Fahrenheit with height

gradient appeared in the atmosphere over the black, oiled runway. Toward evening this negative gradient tended to decrease, and by early evening to disappear altogether. Preliminary tests and subsequent measurements and calculations revealed an upward refraction of sound under the negative temperature gradient of midday, but no such refraction in early evening. At midday the shadow zone caused by refraction, depicted in Figure 2 and calculated^{3c} on the assumption of no diffraction and scattering,

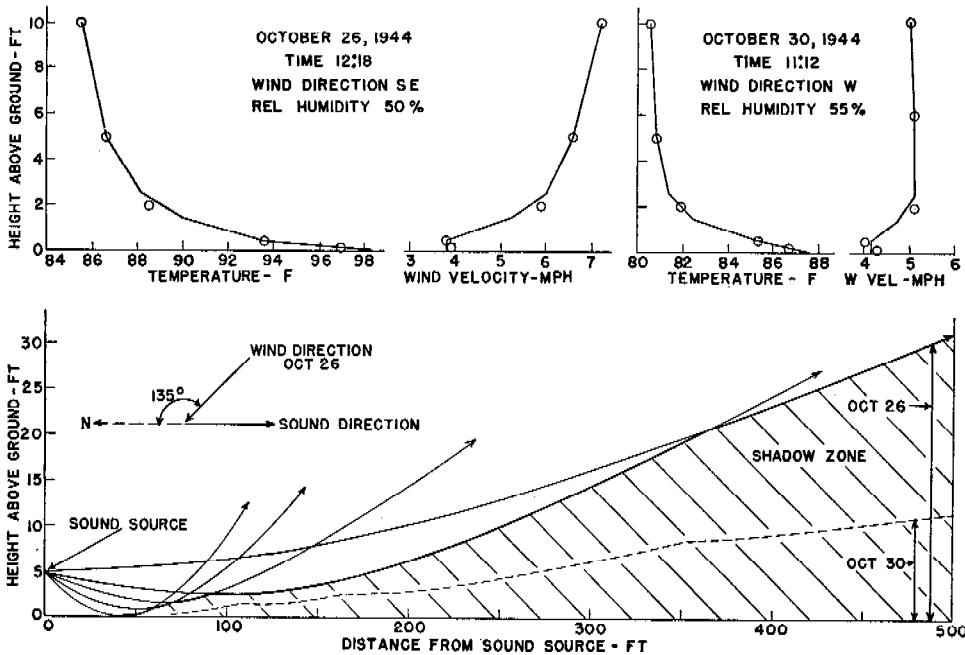

FIGURE 2. Shadow zone over heated bare surfaces.

above the ground in feet; a wind velocity profile is a similar plot of wind velocity in miles per hour and height in feet (see Figure 3).

Temperature Gradient (S_t). The temperature gradient, in degrees Fahrenheit per foot, is the slope of the temperature profile curve. If the slope is negative, the gradient is known as a lapse rate; if positive, as an inversion.

Wind Velocity Gradient (S_v). The wind velocity gradient, in miles per hour per foot, is the slope of the wind velocity profile.

8.2.3

Measurements

Hard Flat Surface. Under the heating of the tropical sun a steep negative temperature gra-

was actually discovered for frequencies above 2,000 c. For lower frequencies, and especially for those below 500 c, the shadow zone was definitely blurred. It was found possible to elevate the microphone until it moved through the shadow and into the beam above (dotted line of October 30). With the effect of the upward refraction thus substantially reduced, the terrain loss might be expected to represent simply the loss caused by the moisture in an atmosphere with a relative humidity of 55 per cent and a temperature of 80 F. At the higher frequencies, the terrain loss coefficients agree remarkably well with Knudsen's values^{5, 6} which he obtained indoors.

With no temperature and wind gradients, re-

fraction would disappear, the shadow zone would be eliminated, and the microphones would not need to be elevated as before. Under this ideal condition (see Figure 3), no terrain loss was clearly shown for frequencies below 500 c; however, the 7,000 and 10,000 c did show a set of experimental values which indicate a

ments having been made under very small temperature and wind velocity gradients.

A study of the curves of Figure 4, labeled to agree with the situations just described, reveals (1) that a rapid rise takes place in the terrain loss coefficient beginning first at about 300 c, and then again at about 4,000 c; (2) that

TABLE 1

Frequency, c	75	150	300	600	1,200	2,400	7,000	10,000
α db per ft (our value)	0	0	0.01	0	0.015	0.011	0.020	0.045
β db per ft (Knudsen's)	0	0	0	0.001	0.002	0.006	0.019	0.033

linear relationship between terrain loss and range and, therefore, a constant terrain loss coefficient, presumably a loss caused by moisture in an atmosphere with a relative humidity of 95 per cent and a temperature of 76 F. As before, a comparison is made with Knudsen's values.

TABLE 2

Frequency, c	7,000	10,000
α db per ft (our value)	0.015	0.027
β db per ft (Knudsen's)	0.0145	0.0265

In summary the following conclusions may be drawn. Over open terrain during daytime, negative temperature gradients are very large (Figure 2) and the upward refraction produced, especially for the higher frequencies, greatly increases the terrain loss near the earth's surface. At night (Figure 3), if the sky is overcast, the upward refraction becomes much less, and the terrain loss approximates that due to atmospheric moisture; if the sky is clear, downward refraction and a further decrease in terrain loss appear an hour or more after sunset. (See Table 3 for estimated terrain loss coefficients for a large variety of meteorological conditions.)

Grass Areas. Five situations were chosen^{3d}: (A) over thinly covered short (6-12 in.) grass; (B) over thickly covered short (18 in.) grass; (C) through thickly covered short grass; (D) through shrubbery and over thick short grass; (E) through thick tall (6 ft) grass. The measured terrain loss coefficients are depicted in Figure 4 and are free, as nearly as practicable, from the effects of refraction, the measure-

between about 600 c and 3,000 c the coefficient for a given terrain remains substantially constant; (3) that for frequencies up to 400 c the

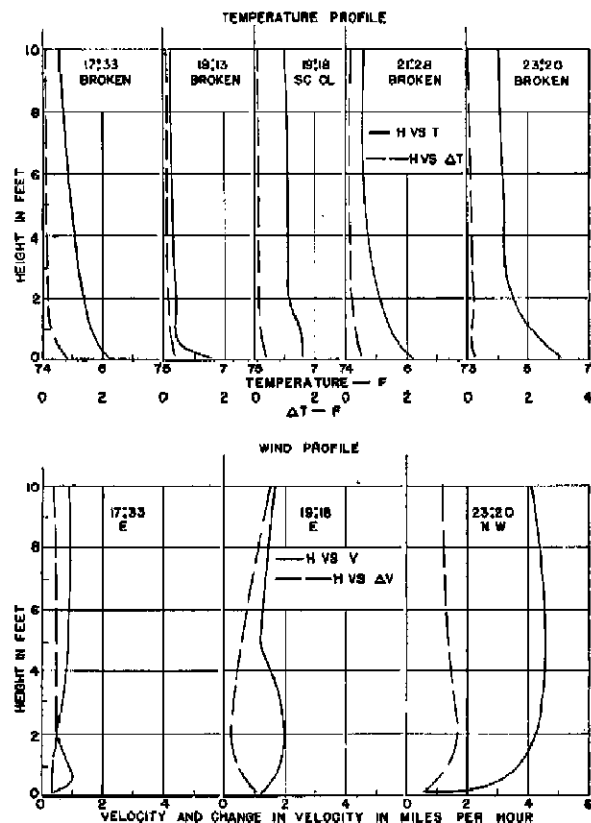

FIGURE 3. Temperature and wind profiles, Madden Field Runway, night, November 13, 1944.

coefficients for tall and for short grass and for shrubbery-covered short grass are approximately of the same magnitude; (4) that for frequencies above 500 c the coefficient is very

sensitive to the type of terrain, for frequencies below 300 c very insensitive. No theory is advanced to explain these observations.

The Tropical Forest. It was found possible to type the tropical jungle as follows: (1) very leafy, one sees a distance of approximately 20 ft, penetrated by cutting; (2) very leafy, one sees a distance of approximately 50 ft, penetrated with difficulty but without cutting; (3)

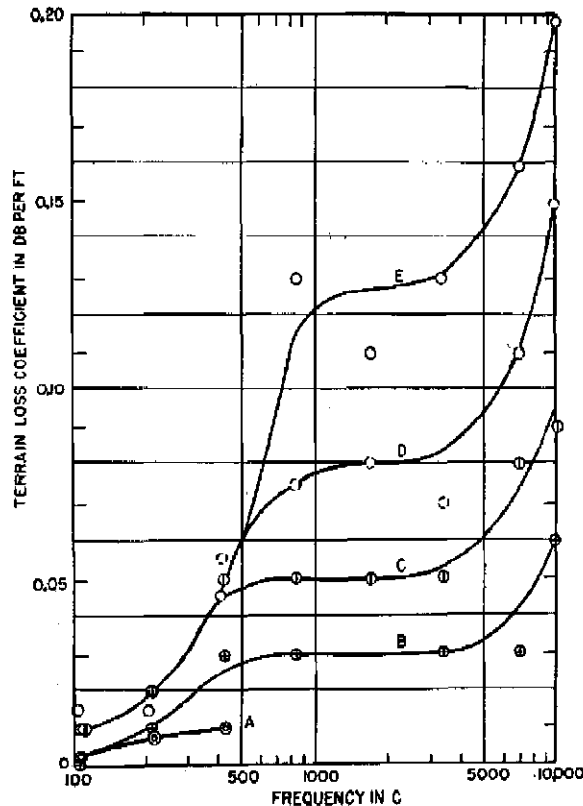

FIGURE 4. Terrain loss coefficients for grass areas,

leafy, one sees a distance of approximately 100 ft, free walking if care is taken; (4) leafy, one sees a distance of approximately 200 ft, penetration is rather easy; (5) little leafy undergrowth, large bracketed trunks, one sees a distance of approximately 300 ft, penetration is easy. By careful selection, representatives of all five types were found and studied.

Within the jungle the temperature and wind velocity gradients were found to be so small that the sound refraction which they produce could be neglected for all practical purposes. The terrain loss coefficients, found to be inde-

pendent of range, for the various types of jungle are summarized in Figure 5, zones being designated to represent the five jungle types described above.

8.3 AMBIENT SOUND OF THE JUNGLE

Jungle Sounds. A jungle far removed from human activities at times may be deathly silent. At other times it is filled with animal sounds: humming, buzzing, chirping, noisy and musical "mate" calls; with the rustle of palms under wind action; with the sound of dropping and rushing water, the result of heavy dew and rain; and even with the sound of thunder. Seldom, if ever, do all possible jungle sounds join in a grand finale. When rain and wind are at their height, animal life is usually quiet; when the weather is fine, birds sing at daybreak; but insects, which have maintained a chorus all night, slowly bring their night calling to a close.

The songs of birds and the calls of insects and amphibia are primarily indications of the breeding season, and, since this period is of comparatively short duration and for each individual occurs only once a year, the major sounds produced by them are distinctly cyclical. In the tropics, however, there is not the concentration of breeding seasons of many species into a few months that one finds in northern latitudes. While the peak of the breeding season for birds, for example, probably occurs in April, there are some birds nesting every month of the year, and the main period extends from February to July. In the case of amphibia, the breeding seasons and resulting calls seem even less regular than with birds and are more dependent on water conditions. Even in one spot like Barro Colorado Island, all individuals of one species do not seem to come into breeding activity at the same time, as they do in northern latitudes, with the result that there will be feverish activity and much singing for a few days followed by a lapse of a week or more with no activity. This all helps to make the general picture of animate sound in the jungle rather complicated.^{4a}

Recordings of Jungle Sounds. Except for the recording of mammal voices, such as those of

the howling monkey with wide band sounds, the microphone was placed at the focus of a 40-in. parabola (see Figure 6) with a resulting gain of from 10 to 25 db and with no noticeable distortion for bird, insect, and amphibian calls. Recordings were made on acetate-coated aluminum disks by the use of Presto disk recording equipment.

resent a series of recordings made with the microphone at a definite spot during a 24-hour period. There will likewise be found on the disks recordings of a few inanimate sounds such as wind, rain, thunder, and running water, as well as airplanes, locomotives, motorboats, etc.^{4b}

Ambient Sound Levels. During early December, two 24-hour records of ambient sound

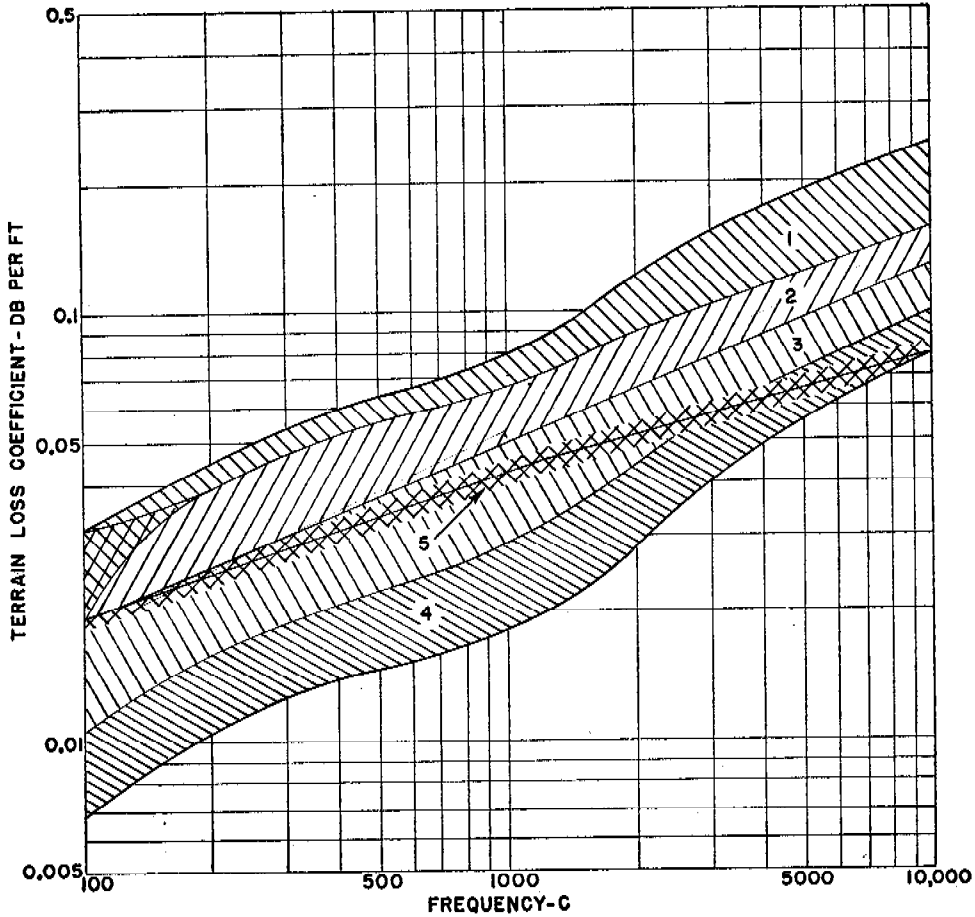

FIGURE 5. A chart from which to estimate terrain loss coefficients for tropical jungles (see text for description of zones).

Altogether, recordings have been made on 57 double-faced records which will require 23 hours of constant playing time. These recordings represent 95 species, of which 78 are birds, 4 are mammals, 9 are amphibia, and 4 are insects. In addition, of course, a small part of the recording is of the general background in different spots where work was done. Some of these recordings represent just a minute or so at daybreak or shortly thereafter; others rep-

resent a series of recordings made with the microphone at a definite spot during a 24-hour period. Readings of levels were made every 30 minutes for overall and for seven frequency bands. The equipment was standardized against a calibrated condenser microphone (Western Electric 640-AA, No. 428), and the field microphone was furnished with a heating

coil to keep it free from heavy dew during the night.

The intensity levels measured every 30 minutes during the 24-hour runs were averaged for 2-hour intervals, and out of these averages a set of masking curves was plotted.^{3e} Also daytime and night averages were obtained. The daytime average for a wet day in a typical jungle (Las Cruces Jungle) is plotted in Figure 7 as *jungle ambient noise*.

Judging Sound Direction in a Jungle. The method consisted of three steps: the random firing of guns at selected locations in the jungle

4. Within the range studied—300 to 600 ft—the error decreases with the distance from the source.

5. Hearing two shots fired in succession in the same general direction does not help in determining the direction of the second shot. (This might not apply if, by the time the second shot is fired, the head had been turned to a more effective angle, see 9 below. Such a technique was not permitted in the experiment.)

6. There is a tendency to fail to remember the exact orientation of the head at the time a sound is heard, and this may lead to recorded



FIGURE 6. Parabolic reflector in use.

—locations not known to the listeners—the judging of the sound direction for each shot, and the recording of each judgment on a specially prepared chart. For details see the original report.^{3f}

In judging the direction of a shot in a jungle, the following conclusions seem to be supported by field measurements:

1. The probable error of judgment is large, of the order of 16.5 degrees.

2. The error is greatest if the sound source is either directly in front or in back—the error may even show marked confusion in these directions.

3. The error is least if the sound source is near the axis passing through the ears.

judgments with persistent errors in one direction—to the right, for example.

7. There is a minor tendency to bring the observed direction into line with the axis passing between the ears.

8. Some observers are better than others—abilities seem to follow a normal distribution.

9. Although the response of a jungle to the sound produced in it will continue to be a hindrance, there is reason to believe that sound direction judgments may be improved by following two simple rules based on the facts brought out in this investigation: (a) keep the orientation of the head at the time when the sound was heard clearly in mind; (b) remember that smaller errors are made when the sound

source is near the axis passing between the ears.

8.4 JUNGLE ACOUSTICS APPLIED TO TACTICAL PROBLEMS

The Problem. The application of jungle acoustics to tactical problems will be illustrated by solving a specific problem: how far away is

few soldiers in most groups have hearing so acute that the solid threshold of hearing curve would best represent their hearing. They would be able to hear a 500-c tone, for example, when its intensity level reached 8 db, and would show a 15-db advantage over the average soldier—an advantage of no use on a noisy battlefield, but in a jungle of great value, as will be seen.

Masking of Ambient Noise. The next step is to find the deafening effect of the natural

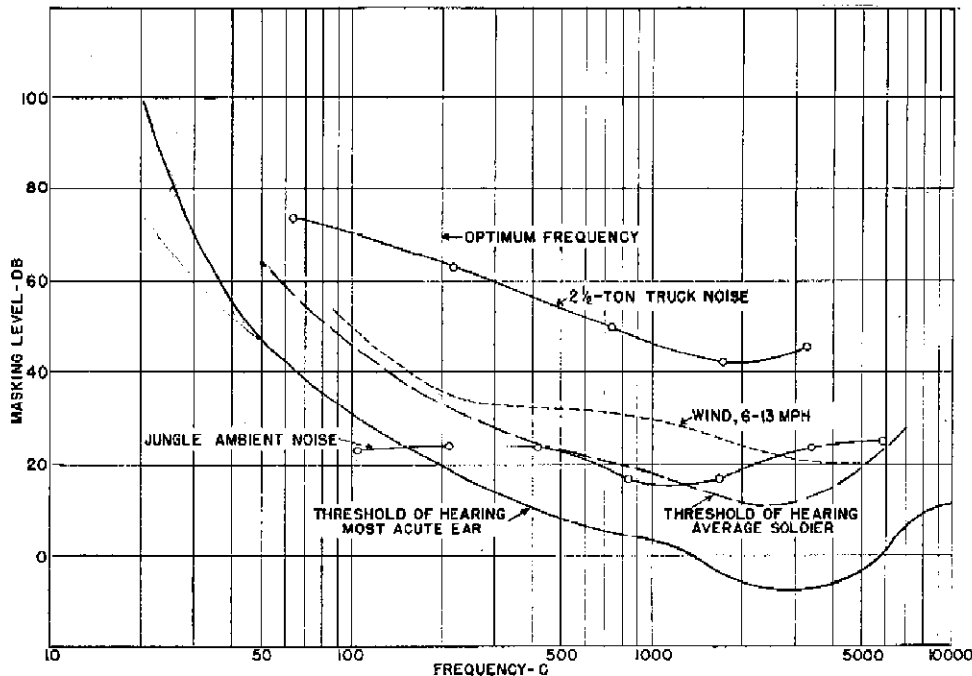

FIGURE 7. Showing masking levels of certain noises.

a 2½-ton Army truck when it can just be heard through a tropical jungle?

Obviously, not all 2½-ton Army trucks make the same noise under all conditions, and tropical jungles differ in density, yet the *average* truck and the *typical* jungle may be used and the problem solved. The solution is made in steps.

The Listener. The listener is assumed to be a young soldier with hearing at least as good as the best 50 per cent of a typical American group. If so, his threshold of hearing is represented by the dashed line in Figure 7. This means that, with *no* other sounds present, a pure tone of a given frequency can just be heard by this soldier when its intensity level reaches the dashed line in the figure. A very

sounds of a jungle. The ambient noise masking level curve for daytime on a wet day in a typical jungle is shown in Figure 7. Below 1,000 c the ambient noise masking level curve either is below or just touches the threshold of hearing curve of the average soldier listener. This means that for frequencies below 1,000 c the average soldier is *not* deafened by the noisy background found in a wet season jungle. This statement applies only to the quiet periods between animal calls, because the peaks were not included in the noise measurements; only the general more or less steady background out of which the occasional calls appear was measured. The soldier will usually be able to select these quiet periods; therefore, the ambient noise

masking level curve submitted is the one to use in practical problems.

It is important to observe that, between 1,000 c and 400 c, the average soldier will hear as well as the one with very acute hearing, because the latter will be deafened by the ambient noise just enough to render him average also. But below 400 c the one with acute hearing will have a definite advantage. This means that *jungle listening* should be assigned to those known to have better than average hearing in the range below 500 c.

In the jungle the air is usually very still, but in open terrain the wind velocity in the tropics, though seldom high, may exceed 10 mph. A listener in such a wind, even though otherwise all is quiet, will be slightly deafened. This may be verified by referring to Figure 7 and observing the masking level curve of a 6- to 13-mph wind.⁷ The soldier with acute hearing has no advantage over the average soldier in such a wind. Notice that the masking at 200 c is 3 db—this information will be needed later.

Sound from Truck. Recent studies² give the distribution-in-frequency of the sounds from various Army vehicles, as measured 100 ft away. The published curves are presented on the basis of octave bands; the one used for a 2½-ton Army truck, and depicted in Figure 7, has been changed to the basis of critical band widths so that all curves in the figure might be comparable.^{8,9}

Intensity Level Available for Transmission Loss. In the jungle the hearing of the average soldier is limited, as has been shown, by his threshold of hearing up to 1,000 c and by the masking of jungle noise for frequencies above that. The difference in level between the masking level curve of the truck noise at 100 ft from the source and the soldier's modified threshold curve is at a maximum between 200 and 500 c.

As the sound from the truck passes through the jungle, it suffers transmission loss, and therefore the masking level curve representing the decreasing truck noise will move steadily down in level. But, since the terrain loss coefficient goes up with increasing frequency, the curve will also get steeper and steeper as it moves downward in level. Were it not for this rotation, one would expect to hear

the truck last in the frequency band between 200 and 500 c, the band with maximum ordinates as explained above. But the rotation, resulting from the increase in terrain loss with frequency, permits the 200 c to be heard last, and it becomes the so-called optimum frequency. The difference in level between the two curves at 200 c is 32 db, and this represents the level available for transmission loss. (The soldier with acute hearing would have 40 db available. In a wind of 6 to 13 mph they both would have 29 db available.)

Distance of Truck from Listener. From the discussion so far it is clear that, if the truck is just to be heard, 32 db are available for transmission loss. To what distance in the jungle does this loss correspond?

First, the terrain loss coefficient must be determined. The jungle which will be considered typical lies at the center of Zone 3, Figure 5. The jungle represented by this zone is leafy, free walking is possible if judgment is used in selecting the path, and with care a person may see a distance of 100 ft. The chart, Figure 5, indicates that 0.02 db per ft would properly represent this jungle for the frequency of 200 c.

With the terrain loss coefficient and the level available for loss determined, the next step is to find the distance by using the set of curves shown in Figure 8. Select the curve corresponding to a coefficient of 0.02; follow out on this line until it has climbed 32 db, and read the distance 750 ft. This is the answer. If an "average" 2½-ton truck is just heard by an "average" soldier in a "typical" jungle on a day in the wet season, it probably is 750 ft away. If just heard by a soldier with acute hearing (40 db available) or if the average soldier recognizes the truck by its peaks of noise, thus gaining from 8 to 10 db, it is probably 1,000 ft away. An experiment was set up to check this solution. The agreement between calculation and experiment was satisfactory.³⁵

Summary of Data. As a summary it seems wise to put down in tabular form the terrain loss coefficients which seem to be appropriate to use for several kinds of terrain under various weather conditions, and also the intensity level available for transmission loss when listening for Army vehicles. It will be assumed that the

listener is in the tropics, that the sound source and ear are 5 ft above the ground, that the optimum frequency at which the sound will be

Terrain loss coefficients for open terrain are so dependent on weather that the values listed in Table 3 must be thought of as estimates; yet

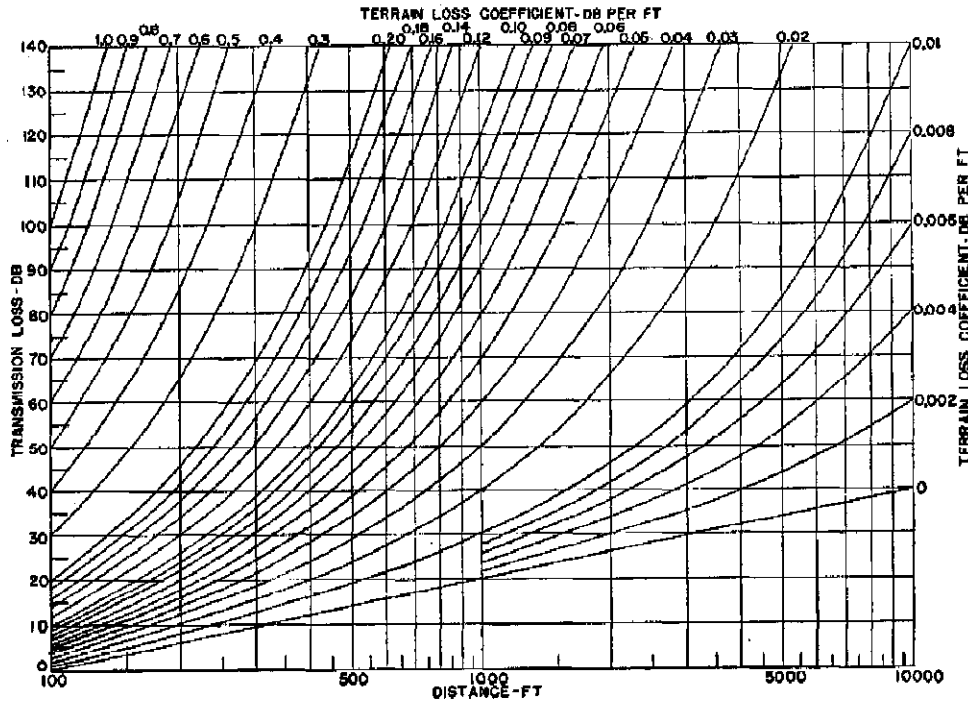

FIGURE 8. Transmission loss as a function of distance.

heard is 200 c (the frequency which seems optimum in a jungle for all Army vehicles), that the only local noise is that natural to a

the values do have a foundation in field measurements in the tropics and in the temperate zone.⁷ Because of a change of vegetation with

TABLE 3. Estimated terrain loss coefficients for open terrain—200 c.

Weather	α (db per ft)	
	Bare or thin grass	Thick grass
Midday, sky clear		
Wind under 6 mph or cross wind	0.005-0.01	0.008-0.01
Head wind 6-12 mph	0.008-0.012	0.008-0.012
Tail wind 6-12 mph	0.005	0.005
Midday, overcast, or early morning or evening, clear		
Wind under 6 mph or cross wind	0.003	0.006
Head wind 6-12 mph	0.006	0.010
Tail wind 6-12 mph	0.002	0.005
Night, sky overcast		
Wind under 6 mph or cross wind	0.002	0.005
Head wind 6-12 mph	0.005	0.009
Tail wind 6-12 mph	0.001	0.004
Night, sky clear		
Wind under 6 mph or cross wind	0.001	0.004
Head wind 6-12 mph	0.005	0.008
Tail wind 6-12 mph	0.000	0.003

quiet terrain and that for the average ear there is no masking if the wind is below 6 mph, and 3 db masking if the wind reaches 13 mph.

the season, a jungle should be typed every time it is involved in a sound transmission problem. At the optimum frequency for listening to Army

vehicles, 200 c, the terrain loss coefficient in the jungle is essentially independent of daily weather changes.

TABLE 4. Terrain loss coefficients for jungles—200 c.

Type of jungle (see text)	α (db per ft)
1	0.04
2	0.03
3	0.02
4	0.015

8.5 MICROMETEOROLOGY IN THE TROPICS

8.5.1 Apparatus and Definitions

Thermistors, used as thermometers and anemometers, were found to be rugged in construction, accurate and reliable in operation, responsive to rapid changes in temperature and wind velocity, and light in weight. Hydrogen-filled

TABLE 5. Intensity level available for transmission loss.

Kind	Vehicle Speed (mph)	Wind velocity	
		0-6 mph	6-13 mph
Jeep	15	19	16
¾-ton truck	15	23	20
2½-ton truck	12	32	29
M5 tractor	10	43	40
8-ton truck	11	48	45

balloons were found useful, both in and out of the jungle, to gain measurements to moderate heights (150 ft maximum). Meteorological field measurements were made over hard smooth surfaces, over short grass, in and over tall grass, in and over low shrubbery, in and over tropical forests. In all these situations^{3h} temperature and wind velocity gradients (illustrated in Figures 2 and 3) were obtained, and from the continuous records, Figure 9, temperature and wind velocity fluctuations and variabilities were determined in keeping with the following definitions:

Temperature and Wind Velocity Fluctuation. The number of times a temperature or wind velocity record (see Figure 9) has a zero slope during a half-minute interval is called the fluctuation of the temperature or the wind ve-

locity. This number, designated as the number of vacillations per half-minute, includes all maxima, minima, and points of inflection with zero slope. Unless the recording equipment has a zero time constant, the fluctuation will be a function of the equipment as well as of the micrometeorological elements. Yet for a given equipment, a comparison of these numbers, ob-

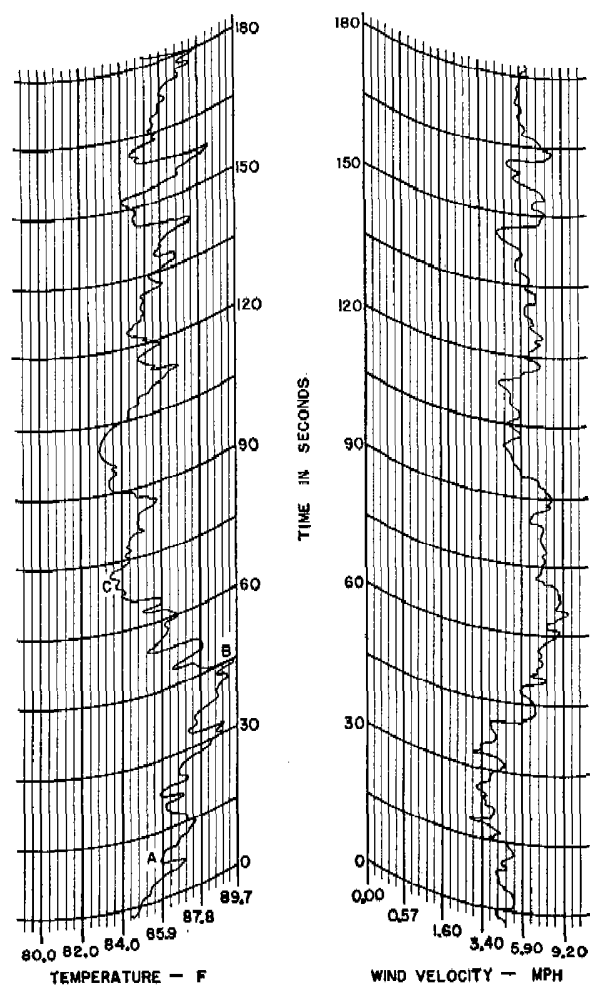

FIGURE 9. Temperature and wind velocity records, Madden Field Runway, October 26, 1944, 1227 EST.

tained for different meteorological situations, may be made with profit.

Temperature Variability (ΔT). One-half of the difference between the maximum and minimum temperature recorded within a half-minute interval is called the temperature variability for the specified position and time of day.

Wind Velocity Variability (ΔV). One-half of the difference between the maximum and mini-

mum wind velocities recorded within a half-minute interval is called the wind velocity variability for the specified position and time of day. Gustiness (G). The ratio, expressed in per

8.5.2

Summary of Temperature Data

Spread of Diurnal Temperature. The spread of diurnal temperature is a function of the

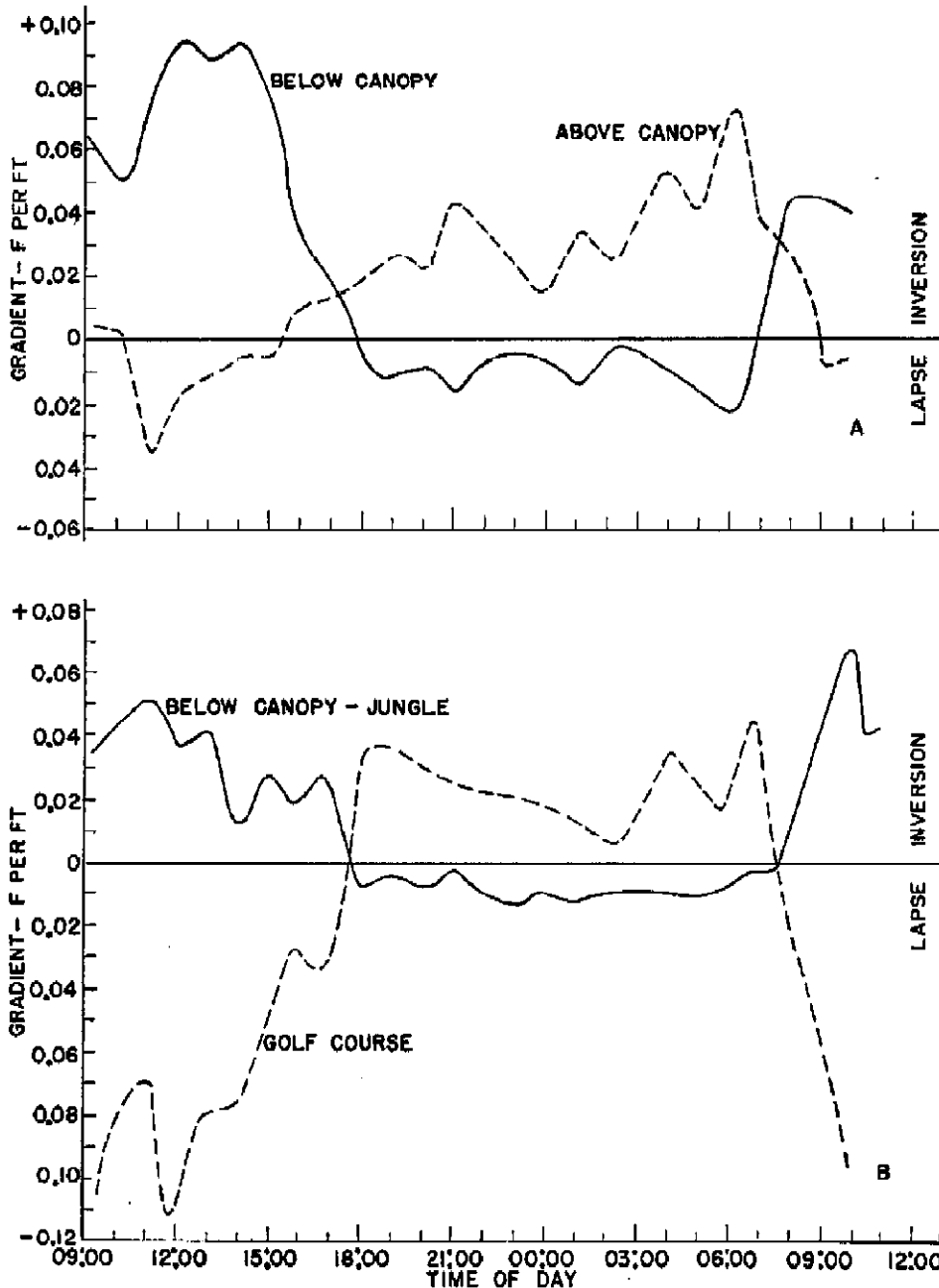

FIGURE 10. (A) Temperature gradients above and below canopy, Las Cruces Jungle, December 4 and 5, 1944. (B) Temperature gradients, Las Cruces Jungle, November 23, 1944, and Clayton Golf Course, December 6, 1944.

cent, of twice the wind variability to the average wind velocity is called the per cent of gustiness.

density of cover, the conditions of the sky, the circulation of the air, and the altitude of the terrain. Over grass or above the canopy of a forest,

the temperature spread in Panama is approximately from 66 F to 86 F.

Temperature Gradient. In Figure 10, diurnal temperature gradients are shown (A) for positions above and below a jungle canopy, and (B) for positions under the canopy of a jungle and over a grass area. Average temperature gradients, thought to be characteristic of Panama terrain and based on a 5-ft layer of atmosphere just above the terrain described, are sum-

3.5.3

Summary of Wind Velocity Measurements

Wind Velocity. Measured wind velocities are summarized in Table 7.

Wind Velocity Gradients. Under the jungle canopy the wind velocity gradient is substantially zero; over the canopy or in open terrain it may reach 0.5 mph per ft.

Wind Velocity Fluctuation. Above the jungle

TABLE 6

Time	Terrain	Kind of gradient	Average value (degrees F per ft)	Description of value
Day	Bare	Lapse rate	-2.0	Maximum
Day	Grassy	Lapse rate	-1.5	Maximum
0900-1500	Forest canopy	Lapse rate	-0.1	Maximum
0700-1800	Under canopy at ground	Inversion	+0.5	Maximum
0700-1800	Under canopy at ground	Inversion	+0.2	Common
0700	Earth's surface	Isothermal	0.0	Less than one hour's duration
Night	Bare	Inversion	+1.2	Maximum
Night	Grassy	Inversion	+1.0	Maximum
1500-0900	Forest canopy	Inversion	+0.1	Maximum
1800-0900	Under canopy at ground	Lapse rate	-0.2	Maximum
1800-0900	Under canopy at ground	Lapse rate	-0.1	Common
1700	Earth's surface	Isothermal	0.0	Less than one hour's duration

marized in Table 6. The time designated may be in error as much as one hour, because of the variability of sky cover, wind, etc.

Temperature Fluctuation. Temperature fluctuations reach a high of about 20 vacillations per half-minute over a bare heated surface and a low of about 3 vacillations per half-minute in the deep jungle.

Temperature Variability. Temperature variability, which is a function of the kind of surface heated, the intensity of the sunlight, the circulation of the air and other factors, is greatest during daytime and least at night. Over bare terrain and near the surface, it may reach 4 F during daytime and drop to 0.5 F at night. Over a grass area its maximum is 2 F. Under a forest canopy it seldom reaches 0.5 F but often falls to 0.1 F. In general the variability decreases with increased elevation, changing over bare terrain from 4 F at the surface to 2 F at an elevation of 10 ft, for example.

TABLE 7

Maximum velocity recorded	17 mph
Under the jungle canopy a maximum of	2 mph
Under the jungle canopy usually less than	1 mph
Over the canopy and open areas	1 to 17 mph

canopy and in open terrain the wind velocity fluctuations approximate 15 vacillations per half-minute, and this value is substantially independent of time of day and elevation. In a jungle the vacillations per half-minute are very few in number.

Wind Velocity Variability. The wind velocity variability generally increases with altitude and is very often equal to half the average wind velocity.

Gustiness. Gustiness is high both under and over the jungle canopy and over open terrain, often reaching 100 per cent, sometimes 200 per cent.

8.5.4

Humidity Measurements

Humidity. Relative humidity in a jungle is always high; it is near 100 per cent about eighteen hours out of the twenty-four; the period of reduced humidity, when during midday relative humidity may fall for a short time to 60 per cent, is often as long as six hours for a

dry season type of day, but may shorten to a few hours for a wet season type of day. At night in the jungle relative humidity is independent of elevation, but during the day it is greatest near the ground. An open terrain shows about eight hours per day of high humidity. During the period of reduced humidity, relative humidity seldom drops below 50 per cent.

ATTENUATION OF SOUND IN THE ATMOSPHERE

By V. O. Knudsen

9.1 INTRODUCTION

BEFORE THE EFFECT of a given sound can be evaluated, and before various desired sounds can be successfully produced, it is first desirable to investigate the factors which cause energy losses in sound waves of finite amplitude when propagated through the atmosphere.^{1, 2} Consequently, this investigation was undertaken, as a part of the project on sound sources, to evaluate the various factors responsible for energy losses in the transmission of intense sounds in air, especially for the frequency range of 500 to 1,000 c. These factors are: (1) absorption at large amplitudes owing to the non-linearity of the medium; (2) absorption from molecular collisions, viscosity, and heat conduction; (3) losses from scattering owing to turbulence in the atmosphere; and (4) influence of the terrain over which the sound is propagated.

9.2 ABSORPTION OF SOUND WAVES OF FINITE AMPLITUDES

1. *Point source measurements.* Using the Western Electric 598-B loudspeaker unit³ (horn removed) in a 4-ft baffle as a point source of sound at 500, 1,000, or 2,000 c in the open air and also in a room with boundaries so absorptive that reflections from the boundaries can be neglected, it was found that the sound pressure varied as $1/r$, where r is the distance from the source, for values of r from about 10 cm to 100 cm and for intensity levels of less than 140 db (the highest level obtainable). Thus, at these frequencies, intensity levels, and short ranges, there were no appreciable losses.

2. *Two-microphone measurements.* In the point source measurements just described there

³ This unit, from which the folded, exponential horn was removed for this part of the investigation, has an 8-in. diaphragm and is capable of delivering (with horn attached) 500 watts of acoustical power at 500 to 1,000 c.

was considerable uncertainty in measuring the distance r between source and microphone. In order to avoid this uncertainty, two microphones were located at fixed distances r_1 and r_2 , and the difference in intensity level at the two microphones was observed as the intensity of the source was increased. If this difference remains constant as the intensity of the source is increased, it can be concluded that there are no losses between r_1 and r_2 which depend upon the intensity. In these experiments, this difference did remain constant for frequencies of 500 to 4,000 c at intensity levels up to 144 db, again indicating no appreciable nonlinear losses.

3. *Absorption in tubes.* Preliminary experiments using a 3-in. tube driven by the 598-B unit indicated that there were no measurable nonlinear losses for intensity levels up to 144 db. After modifying the driver and tube so as to give higher intensity levels, measurable losses of about 0.5 db per m began at 160 db and increased to about 1.5 db per m at 165 db, the highest level at which data were obtained in this investigation. These losses are about twice as large as those predicted by extant theory on waves of finite amplitude.

From the foregoing experiments it is concluded that for intensity levels up to 155 db the nonlinear losses were too small to be measured and that the total losses cannot be much greater than those resulting from molecular collisions, viscosity, and heat conduction. However, nonlinear losses became appreciable at levels of 160 db, and at 165 db have increased to about 1.5 db per m. Undoubtedly, the rate of loss will continue to increase as the level rises above 165 db.

9.3 ATTENUATION OF SOUND WAVES OF SMALL AMPLITUDES—ABSORPTION AND SCATTERING

The experiments described in Section 9.2 indicate that at intensity levels below about 150

db the nonlinear losses are negligible. It is to be expected therefore that at such levels the losses will be (1) absorption resulting from molecular collisions, viscosity, and heat conduction, and (2) scattering from inhomogeneities in the atmosphere. The absorbed sound can be calculated; at the frequencies of interest to this project, that resulting from molecular collisions is predominant, and the remainder can be neglected. If the measured losses agree with this calculated absorption, it can be concluded that

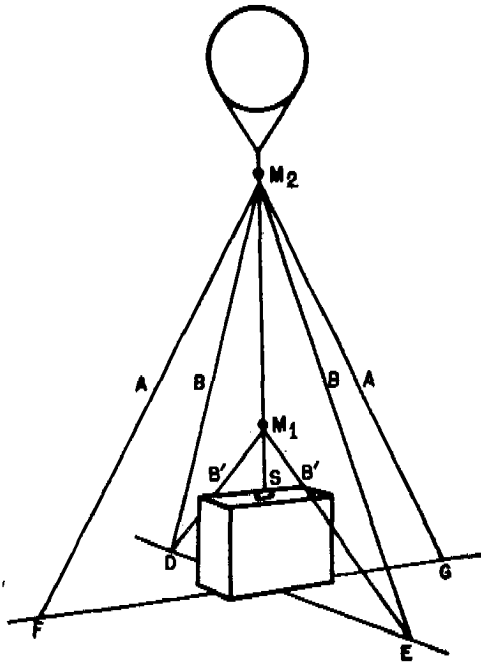

FIGURE 1. Balloon setup.

all other losses, including scattering, are negligible.

This conclusion is indeed supported by the following experiments.

1. *Integration measurements.* The sound power radiated from a point source within a given solid angle would be conserved as it is propagated away from the source if there is no absorption or scattering. Conversely, if the power flux within the same solid angle is less at a distance r_2 than it is at a distance r_1 ($r_2 > r_1$), then there are losses from absorption and/or scattering. Suppose P_1 is the power flux at r_1 and P_2 that at r_2 . Then the transmission loss [TL] in decibels per unit length is

$$TL = \frac{10}{r_2 - r_1} \log \frac{P_1}{P_2} \quad (1)$$

Measurements of this TL were made in the open air, using as a source the 598-B speaker mounted on an inclined track in a large rectangular body on a 1½-ton truck. The speaker can be pulled to the top of the truck's body and projected vertically through a hole in the roof (the roof serving as a baffle), or lowered to the bottom of the track and projected horizontally through a baffle board attached to the rear of the truck's body. Most of the tests were made with the sound projected vertically upward. The general arrangement is shown in Figure 1. P_1 and P_2 were determined by means of a sound level recorder associated with two microphones. M_1 and M_2 were kept at distances r_1 and r_2 from the source by means of a balloon and guy wires. These could be moved slowly, along arcs of radii r_1 and r_2 , across the center of the solid angle (which is symmetrically disposed around the axis of sound beam) in which the sound power flux was measured. The power flux through a given zone is then proportional to product of the average squared pressure over the zone times the area of the zone. When these quantities are summed for the entire solid angle considered (usually the one-half plane angle was 5 degrees) at r_1 and r_2 , the two resulting numbers are proportional to P_1 and P_2 , and the ratio of the two numbers is P_1/P_2 . The TL can then be calculated by equation (1). In a series of 37 sets of measurements for a tone of 500 c and for distances up to 90 m, the observed attenuation ranged from -0.0400 to 0.0600 db per m, with a mean value of 0.0125 ± 0.0013 db per m.

2. *Two-microphone measurements.* In a series of measurements similar to those described in Section 9.2, but for vertical projection, the attenuation in desert air (about 25 C and 20 to 25 per cent relative humidity) was too small at 500 and 1,000 c to be measured by this method, but at 2,000 c the observed attenuation was 0.06 db per m and at 4,000 c it was 0.09 db per m. This result for 4,000 c compares with about 0.06 db per m which is estimated for air of about the same temperature and humidity from more reliable measurements made in reverberation chambers.³

All the experiments conducted on the attenuation of sound in the open air during this in-

vestigation support the conclusion that losses from scattering are not large—probably less than 0.01 db per m for usual atmospheric conditions—and that at frequencies of about 2,000 to 4,000 c the principal loss can be accounted for by molecular absorption.

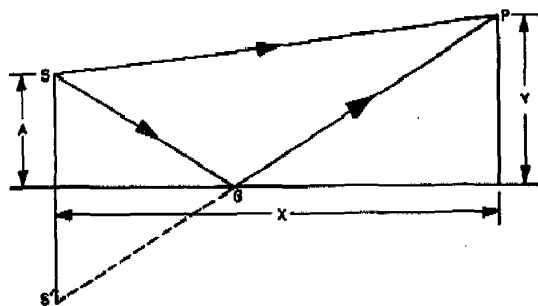

FIGURE 2. Propagation over a reflecting surface.

9.4 TRANSMISSION OF SOUND OVER DIFFERENT TYPES OF TERRAIN

In the practical case of the transmission of sound over the ground, the nature of the terrain may greatly influence the transmission. A typical case is illustrated in Figure 2. The source *S* is located at a height *A* above a level terrain. The sound field at *P* is made up principally of two components, that which comes directly from *S* and that which has been reflected from

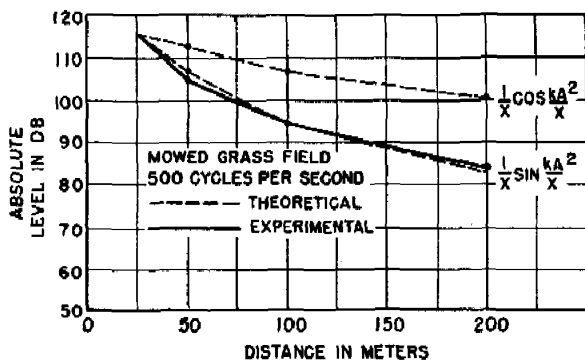

FIGURE 3. Intensity as a function of distance.

the ground (and appears to come from the image of *S*, i.e., from *S'*).

If *A* and *Y* are small compared to *X*, and the reflection coefficient is unity, the absolute value of the sound pressure at *P* is

$$p = \frac{2p_0}{X} \cos \left(\frac{kAY}{X} + \frac{\alpha}{2} \right), \quad (2)$$

where $k = 2\pi/\lambda$, p_0 is the maximum instantaneous sound pressure at *P* from the direct sound wave alone, and α is the phase angle introduced at the ground reflection.

If the specific acoustic impedance of the ground is greater than that for air, the angle α will be zero, and equation (2) becomes

$$p = \frac{2p_0}{X} \cos \frac{kAY}{X}. \quad (3)$$

If the ground is a porous absorber, in which the specific acoustic impedance is less than that for air, the angle α will approach π and equation (2) then becomes

$$p = \frac{2p_0}{X} \sin \frac{kAY}{X}. \quad (4)$$

It will be seen from equations (3) and (4) that when kAY/X is very small, the sound pressure

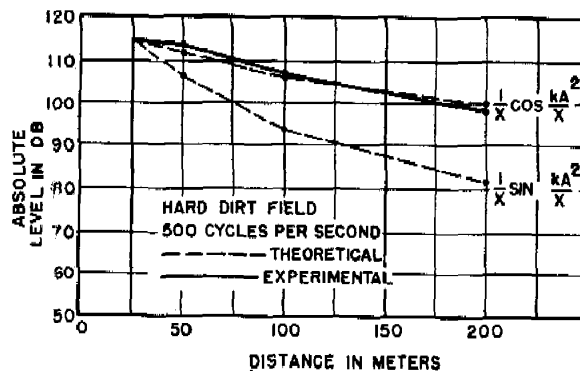

FIGURE 4. Intensity as a function of distance.

at the point *P* varies inversely as the distance *X* when there is no change of phase at reflection, but varies inversely as the square of *X* when there is a phase change of 180 degrees.

Measurements of the sound field made over different terrains revealed that the sound pressure was given either by equation (3) or equation (4). The results for two different terrains are shown in Figures 3 and 4, for $A = Y = 1.5$ m. Figure 3 is for a mowed grass field for which it appears the grazing incidence sound was reflected with a change of phase of 180 degrees, and Figure 4 is for a hard dirt field for which it appears there was no phase change at reflection.

Measurements made over other terrains indicated that, at least approximately, a dry lake surface (many cracks penetrating surface), an alfalfa field, brush 18 in. high, brush 3 ft high (in clumps), and brush 3 ft to 5 ft high, all introduced a phase change of 180 degrees at reflection, that is, the distribution of sound pressure conformed well with equation (4); whereas the sound field over an asphalt road as well as the hard dirt field conformed with equation (3).

As a further check of the applicability of equations (3) and (4), measurements were made

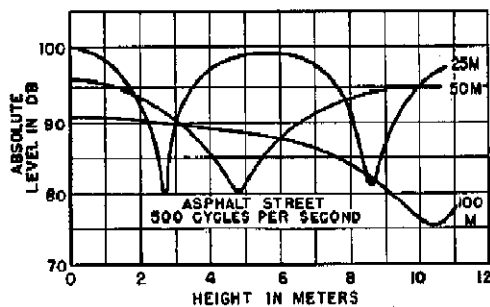

FIGURE 5. Intensity as a function of height.

of the vertical distribution of the sound intensity level at various distances from the source. Figures 5 and 6 show the results obtained over an asphalt street and a mowed grass field, respectively.

Inasmuch as most surfaces likely to be encountered in warfare are probably of the type which will introduce a phase change of about 180 degrees for reflection of sound at near grazing incidence, the interference between the direct and reflected rays of sound appears to be the controlling factor in determining the transmission loss. For the frequencies here considered, this loss is far greater than the combined effects of absorption and scattering.

9.5 OTHER FACTORS AFFECTING TRANSMISSION LOSS

For long-range propagation of sound, temperature and wind refraction are often the controlling factors. However, since the present investigation was limited to short-range propagation of sound, these factors were generally negligible. It was necessary, however, to make the foregoing measurements only when the wind speed was less than about 400 ft per min.

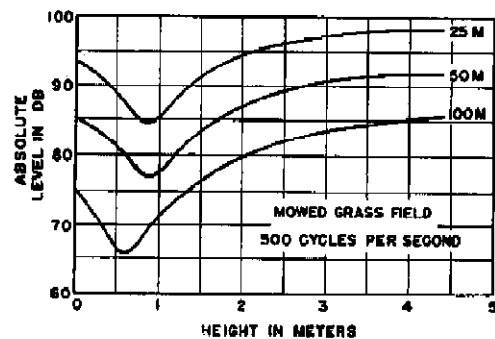

FIGURE 6. Intensity as a function of height.

The errors introduced by higher wind speeds were not those resulting from refraction but those from fluctuations of sound intensity owing to the gustiness of the wind. These fluctuations also are troublesome when there are large temperature inhomogeneities in the air; these are especially prominent when the sun is shining and the measurements are made over a terrain for which the heat absorption varies greatly from one area of the terrain to another. At high wind speeds the refraction effects were very prominent for the ranges of less than 100 m. For example, with a wind speed of 2,640 ft per min, for horizontal projection of sound at a height of 1.5 m and a range of only 50 m from the source, the level at various azimuths varied from 92 db against the wind to 102 db with the wind.

Chapter 10

INJURIOUS EFFECTS OF EXPOSURE TO LOUD TONES AND NOISES

10.1 INTRODUCTION

EARLY IN WORLD WAR II, a project was originated at Harvard University under Section C-5, NDRC, to study the physiological effects of exposure to certain sounds. Later this work was transferred to the Committee on Medical Research [CMR] and continued under their auspices. This report includes the significant results from both the Harvard¹ and CMR^{2, 3} reports.

10.2 HEARING LOSS PRODUCED IN HUMANS

10.2.1 Description of Experiments

The ears of 15 young men (17 to 21 years) and of 4 older men (29 to 46 years) were repeatedly exposed at intervals of several days to intense tones of frequencies of 500, 1,000, 2,000, and 4,000 c at intensities of 110, 120, and 130 db for periods of from 1 to 64 minutes. A noise of continuous frequency spectrum, somewhat resembling airplane noise, was also employed.

Following each exposure, tests were made of the threshold of auditory sensitivity and of the ability to understand words spoken in an A-9 oxygen mask, recorded through an MC-254 carbon microphone heard through a standard headset (Murdock R-14). In many experiments the perception of loudness at various intensity levels was also measured, and several studies were made of the distortion of pitch perception (diplacsis).

Temporary impairment of hearing was regularly produced, but there was no evidence of cumulative injurious effects. The only definite permanent hearing loss (32 db at 3,400 c) was produced by a 20-minute exposure in four 5-minute periods to 500 c at 140 db. Intensities above 140 db can probably be tolerated for many seconds without permanent damage, but such intensities have not been systematically

explored with the human ear. At 500 c the pain at the eardrum produced by 140 db is definite for the first few seconds and then passes off. It is less for 1,000 c and 2,000 c. Evidence of mild labyrinthine stimulation, especially when the tone is turned on and off, appears at about 140 db. Pain is not an index of the effectiveness of a tone in causing deafness. Neither temporary incapacity from pain or labyrinthine stimulation nor any permanent deafness has been produced by exposure to pure tones from 500 to 2,000 c at 140 db for periods up to 5 minutes.

Interruption of a tone by brief periods of silence (1 to 5 seconds) does not alter its effectiveness in producing hearing loss. One minute of exposure to a continuous tone produces substantially the same hearing loss as 2 minutes of exposure to alternate periods of 1 second on, 1 second off. More rapid interruption decreases slightly the hearing loss produced. The discomfort from the interrupted tone is greater, however, than that from the corresponding steady tone.

No significant elevation of auditory threshold is produced for tones of frequency lower than the exposure tone. The greatest hearing loss occurs at a frequency about half an octave above the exposure tone. With brief exposures the loss may be confined to the two octaves above, but with the longer exposures the hearing loss may be quite extensive for all tones above the exposure frequency.

10.2.2 Summary of Results

Taking as a measure of hearing loss the average loss throughout the two octaves above the exposure tone, it was found that:

1. 1,000 c and 2,000 c are about equally effective in producing hearing loss.
2. 4,000 c is much more effective and 500 c is much less effective than 1,000 or 2,000 c.
3. Hearing loss develops most rapidly during the first minutes of exposure and then more and more slowly.

4. More intense tones usually cause greater hearing losses, but 1-minute exposures to 2,000 c may be *less* effective at 135 db than at 125 or 130 db.

5. The complete relations of hearing loss to frequency, intensity, and duration are complex.

6. Recovery of hearing usually begins rapidly and then progresses more and more slowly. Recovery from a 60-db hearing loss may require four or five days to be complete. Recovery tends to be slowest for frequencies of about 4,000 c, regardless of the frequency of the original exposure tone.

Some men are much more susceptible than others to the production of hearing loss. There are differences also as to the part of the frequency range most readily affected, as well as in the rate of recovery from a given degree of loss. Occasionally any one man may deviate considerably from his usual susceptibility. The results of exposure to 2,000 c are more variable than for the other frequencies.

The impairment of hearing produced by exposure to loud tones or noise is of the variable or nerve deafness type. In spite of elevations of threshold of 50 or 60 db, there may be little or no loudness loss for sounds at the 100-db loudness level. Losses at this level rarely exceed 6 db. *The audiogram alone is not an adequate measure of the impairment of auditory function.*

The modification of loudness perception is shown to be more complex and variable than has hitherto been described either for nerve deafness or for masking with a background noise of continuous spectrum.

Exposure to a pure tone that causes a hearing loss that is restricted to a relatively narrow range of frequencies may cause very severe distortion of pitch perception (diplacsis). Tones of certain frequencies sound noisy and impure or they may be abnormally elevated in pitch by as much as three-quarters of an octave. The major displacements of pitch are always upward. Exposure to a band spectrum noise (like airplane noise), which causes a widespread hearing loss that is usually most severe in the high-frequency range, is relatively ineffective in producing diplacsis.

The impairment of understanding of speech is more closely related to the *overall loudness*

loss at the intensity level at which the speech is heard than to the threshold audiogram or to loudness loss in any special portion of the speech frequency range (400 to 4,000 c). Prolonged exposure to an intense 500-c tone or to noise of wide frequency spectrum causes severe articulation loss at a low (40-db) loudness level but only moderate loss at a high (100-db) level. The articulation loss for loud speech following the 500-c exposure tends to be the greater of the two, even though the average hearing loss measured by audiogram is less, probably because of the greater diplacsis produced by the exposure to the pure tone. Exposure to an intense 1,000-c tone may or may not produce a measurable articulation loss for loud speech, and exposures to 2,000- and 4,000-c tones cause but little articulation loss, even at the 40-db loudness level, for speech heard through a standard Army headset.

10.5 EXPERIMENTS WITH ANIMALS

Guinea pigs were exposed to pure tones of various frequencies at intensities from 140 to 157 db. The effects of 500 c and 1,000 c were most completely explored. Severe and extensive damage to the cochlea may be caused by loud tones without apparent injury to the eardrum, ossicles, or vestibular apparatus. The least detectable anatomical damage to the inner ear, i.e., the disappearance of mesothelial cells from a limited area of the lower surface of the basilar membrane, was produced by 1,000 c at 140 db for 3 minutes. More severe and extensive damage is produced by more intense tones and by longer exposures, and includes degenerative changes in the sensory cells, rupture of the organ of Corti, and dislocation of the organ of Corti from the basilar membrane. A few days or weeks after severe exposure, the organ of Corti disappears where it has been severely damaged, and the nerve fibers and ganglion cells degenerate.

The milder degrees of damage are localized, but a very severe exposure (150 db for several minutes) causes widespread permanent damage. The damage tends to be located nearer the helicotrema when caused by low tones and

nearer the oval and round windows for high tones.

The electrical activity of the cochlea (Wever and Bray effect or aural microphonics) is impaired by exposures which cause definite anatomical changes in the inner ear. There is some general correspondence between changes in the electrical audiogram and the anatomical damage, but the parallelism is not exact or invariable. The anatomical changes are the more

consistent, and it is believed that the electrical audiogram is not so satisfactory or reliable a method of assessing injury to the ear as microscopic examination.

These experiments with animals probably demonstrate the nature of the injury to human ears that would be produced by sufficiently intense continuous sounds, but they do not indicate the intensities or durations of exposure necessary to produce such injury in man.

Chapter 11

HIGH-INTENSITY SOUND PRODUCED BY CHAIN EXPLOSIONS

11.1 INTRODUCTION

VARIOUS DEVICES have been proposed for the production of a sound of sufficient intensity to disrupt auditory communication over a large area. This chapter treats the theoretical problem of covering an area of 1 sq mile with a minimum sound intensity of 120 db by detonating a series of small explosive charges.

The calculations in this study¹ were based on measurements of the pressure level and dura-

problem of forming a continuous sound from unit explosions, special consideration was given to the time interval between detonations which will yield the highest efficiency from the explosive material.

In Table 1 the first three lines show the basis of choice of the interval used in the calculations. The first line shows the total duration of the first three pulses, which contain nearly all of the acoustic energy, of an explosion at a distance of 1,100 ft. The third pulse in some in-

TABLE 1

	Wave combination	Weight per charge (lb)						
		1/4	1/2	1	2	4	8	16
Group 1	3/2	19.7	25.8	25.3	33.9	37.8	45.0	48.9
Duration at 1,100 ft (msec)	5/4	14.4	16.7	19.4	21.1	25.0	30.5	37.8
	33.3	33.3	33.3	33.3	33.3	33.3	33.3	33.3
Group 2	3/2	118.53	122.19	126.79	128.99	132.40	132.98	135.16
Pressure levels in db above 0.0002 dynes per sq cm corrected to 1,000 ft	5/4	120.70	124.72	128.61	131.83	135.28	135.54	135.75
	33.3	116.31	121.06	125.68	128.99	133.26	135.08	137.56
Group 3	3/2	887	1,183	1,684	1,994	2,591	2,708	3,187
Distance at which pressure level is 120 db = radius of 120-db circle (ft)	5/4	1,053	1,437	1,936	2,480	3,232	3,297	3,350
	33.3	753	1,085	1,547	1,994	2,767	3,183	3,850
Group 4	3/2	2.47	4.40	8.91	12.49	21.1	23.1	31.9
Area of 120-db circle × 10 ⁺⁶ sq ft	5/4	3.48	6.49	11.77	19.32	32.8	34.1	35.3
	33.3	1.78	3.70	7.52	12.49	24.0	31.8	46.6
Group 5	3/2	5.14	4.40	4.42	4.72	5.01	7.70	10.25
Lb per sq ft per sec × 10 ⁻⁶	5/4	5.02	4.61	4.36	4.90	4.88	7.68	12.00
	33.3	4.22	4.06	3.98	4.80	5.00	7.55	10.30

tion of single explosions of various weights of dynamite. Sound level meters do not give true indications of actual pressure levels, either instantaneous or rms, such as can be derived from analysis of oscillograms, but properly used they yield useful comparative data.

stances dips near the neutral line without crossing it. In these cases that portion of the pulse which lies beyond the arbitrary termination of the curve has been neglected. The durations of the first two pulses increase with distance from the source. All pressure levels have been corrected to 1,000 ft.

The duration shown in the second line is the interval between the beginning of the explosion and the peak of the second positive pressure pulse. If all pulses were of equal duration, this would be the period of five-fourths of one cycle and has been (loosely) so designated.

11.2 METHODS OF COMBINING UNIT EXPLOSIONS

The wave forms of explosive sounds are illustrated in Section 12.1. In the theoretical

In the third line an interval of 33.3 milliseconds between detonations has been arbitrarily selected.

Figures 1, 2, and 3 illustrate the three methods of combining individual detonations described above to form continuous sound. The

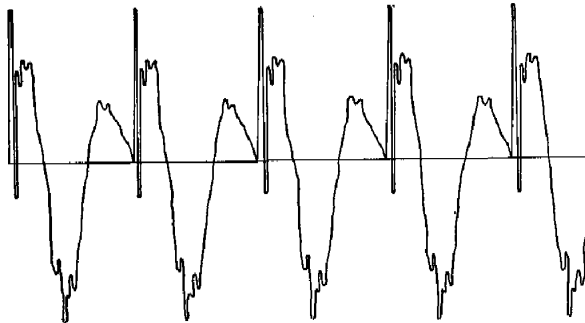

FIGURE 1. The "3/2-cycle" method of combining explosions to form continuous sound.

combinations shown have been formed from the oscillogram of the wave resulting from exploding a $\frac{1}{4}$ -lb charge of dynamite.

11.3 INTENSITY AND RATE OF ATTENUATION

The second group of three lines in Table 1 shows the pressure levels in decibels above

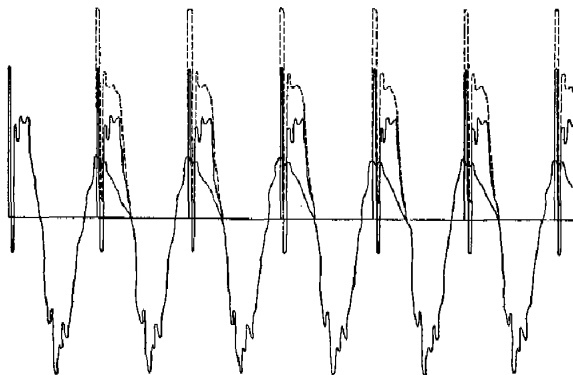

FIGURE 2. The "5/4-in.-cycle" method of combining explosions to form continuous sound.

0.0002 dyne per sq cm at a distance of 1,000 ft, derived from the above wave combinations. These are the theoretical intensities at 1,000 ft derived from the respective wave combinations

above described and with the various weights of charges shown.

The third group of three lines shows the distance from the source at which the intensity will be 120 db, assuming 9 db attenuation per distance doubled. The rate of attenuation per distance doubled is a variable depending upon the frequency spectra of the sound, the coefficient of absorption of the terrain, and the distance from the source. The attenuation due to absorption varies directly as the distance, so that in doubling a large distance the absorption is greater than in doubling a small one. The average rate of attenuation of gun and simulant sounds observed between 1,500 and 8,700 ft, using General Radio sound level meters at Fort Bragg, the terrain being sandy soil cov-

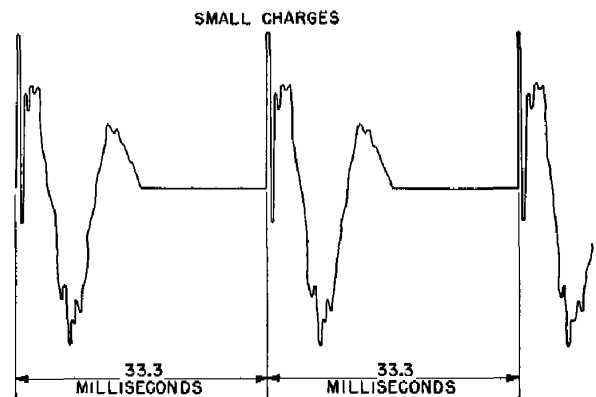

FIGURE 3. The "33.3-millisecond" method of combining explosions to form continuous sound.

ered with thin grass and occasional low shrubbery, in clear summer weather, was 9.9 db. The average attenuation observed at Pine Camp in measuring two-cycle motor sounds at distances ranging from 1,000 ft to 2 miles was 8.9 db.

The fourth group shows the areas of the circles corresponding to the radii designated in the third group. Each circle represents the area within which the intensity will not be less than 120 db.

The fifth group indicates the number of pounds of explosive per second per square foot required to give 120 db at the periphery of the circles with various weights of unit charges. The values shown in the fifth group have been used as a "figure of merit" in choosing the weight of explosive per charge and time inter-

val between charges to be used in an acoustic bomb.

The lowest number of pounds of explosive per square foot per second shown in Group 5 is 3.98×10^{-6} . This value is derived from exploding 1-lb charges of dynamite at intervals of 33.3 milliseconds.

The reason for the rapid increase in the number of pounds of explosive per square foot per

the circle, the more efficient the use of the explosive.

There is a lower practical limit to the size of the charges. This will be determined by the lower practical limit of the distance between bombs, bearing in mind that these must be placed by dropping from the air. This lower practical limit between bombs rather than the variation in efficiency with variation in the weight of the charge may prove to be the final factor in determining the weight selected for the individual charge.

The efficiency of a bomb composed of $3\frac{1}{2}$ -lb charges was compared with that of seven bombs composed of $\frac{1}{2}$ -lb charges. By calculation it was determined that a bomb of $3\frac{1}{2}$ -lb charges firing at 33.3 millisecond intervals will cover a circle with 120 db or more having an area of 21.302×10^6 sq ft. A bomb of $\frac{1}{2}$ -lb charges will cover a circle of 3.697×10^6 sq ft. Seven such bombs used separately will cover 25.879×10^6 sq ft or an increase of 19 per cent. If seven bombs are used in a group as shown in Figure 4, the area covered by the seven is calculated to be 35.71×10^6 sq ft or 67.5 per cent more than covered by a single bomb of the same weight of explosive.

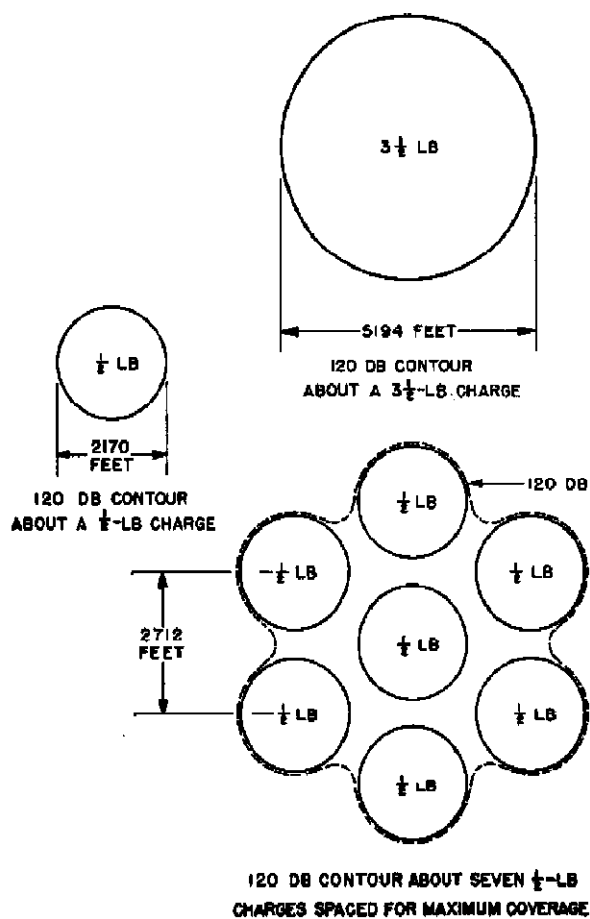

FIGURE 4. Equal intensity contours.

second with increased charges stems from the fact that the rate of attenuation is assumed to be 9 db rather than 6 for each doubling of the distance, while the increase in intensity from doubling the charge approximates 3 db. Also the larger the circle, the greater the intensity at the source, and, since 120 db is adequate to disrupt communications, greater intensity theoretically adds no advantage but consumes extra energy. It therefore appears that the smaller

11.4 SUMMARY AND EVALUATION

It is concluded that an area equal to 1 sq mile may be covered with an intensity of not less than 120 db by detonating three acoustic bombs spaced 3,868 ft apart, each bomb consisting of multiple charges of dynamite, or its equivalent, each charge weighing 1 lb, fired at the rate of 30 per second. The weight of explosive per square mile per minute is estimated to be 5,400 lb, and the weight of explosive per bomb—each bomb being capable of 10 minutes' continuous operation—is 18,000 lb.

It is apparent that under almost all circumstances the same weight of explosive used in the normal manner will be more effective than the acoustic bomb. It is conceivable, however, that under some conditions the acoustic bomb may be justified even at its high cost.

No consideration is given herein to the numerous design problems connected with constructing an acoustic bomb. Not only must all

detonations occur in their time sequence with great accuracy, but at the instant of detonation each charge must be sufficiently removed from the undetonated charges to avoid either destroy-

ing or detonating them. The cost of production and the complexity of handling are two further factors imposing lower practical limits on the size of the charges.

Chapter 12

SOUND SIMULATION AND MASKING

12.1 SIMULATION OF SMALL ARMS AND ARTILLERY FIRE: "CHARLIE"

THE WORK DESCRIBED in this section¹ was undertaken at the request of the Navy, the original object being to provide a package, weighing not more than 4 lb and suitable for attachment to an airborne dummy paratrooper, which would simulate mixed machine gun and rifle fire for a period of 10 minutes. The work was later continued at the request of the Army. Simulants were then designed for both air and ground placement, under less rigid specifications with respect to weight. Mortars of 60 and 81 mm and, later, guns of heavier caliber were simulated.

The dummy paratrooper has been referred to in both Navy and Army circles as "Oscar." The sound-simulating device became known as "Charlie." As the caliber of guns simulated has been extended, the name "Charlie" has remained. As herein used, "Charlie" is a deceptive general term used to designate specific devices for simulating:

1. Rifle and machine gun fire: .30 and .50 caliber;
2. Mortar fire: 60 and 81 mm;
3. 90-mm guns;
4. 105-mm howitzers;
5. 155-mm howitzers;
6. 155-mm guns.

12.1.1 The Character of Explosive Sounds

Preparatory to the selection or design of appropriate simulants, consideration was given to the nature of the sounds to be imitated. Oscillograms of the time pressure wave of the guns and their simulants were photographed with a 35-mm camera. The sweep circuit was triggered by energy from a microphone. A second microphone was used to energize the vertical circuit of the oscilloscope. The sweep circuit

microphone was placed 1 to 3 ft nearer the sound source than the sound pressure microphone.

Figure 1 is an oscillogram of a 90-mm gun and 1 lb of TNT taken at a distance of 1,500 ft from the source. These oscillograms of explosions are typical in that the initial pressure rises rapidly and is usually capped by a sharp peak. Some fluctuations in pressure, however, are evident near the peak. With dynamite the

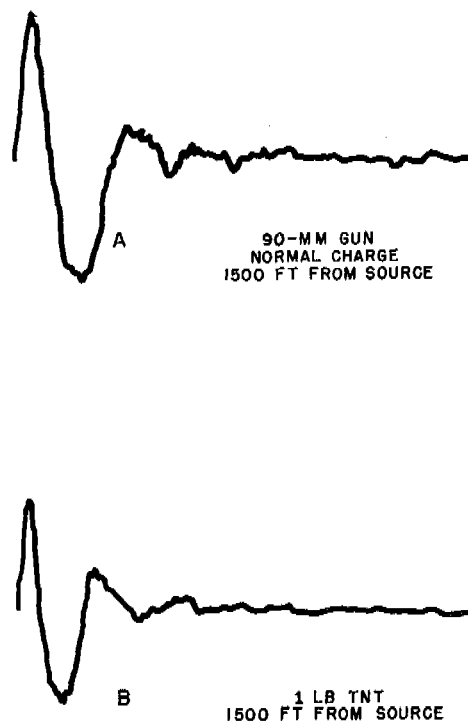

FIGURE 1. Oscillogram of 90-mm gun and its simulant at 1,500 ft.

pressure of the first fluctuation drops abruptly to the vicinity of the neutral pressure line, the oscillogram thus forming an initial sharp sliver. At greater distances the sharp peak sometimes becomes a flat jagged top as shown in the oscillogram of the 105-mm howitzer and its simulant in Figure 2. The negative pressure portion of the first cycle is usually more rounded and contains more energy than the positive pressure portion. The second positive pressure pulse is less intense than the first, is more rounded, and usually flattens as it approaches the axis of

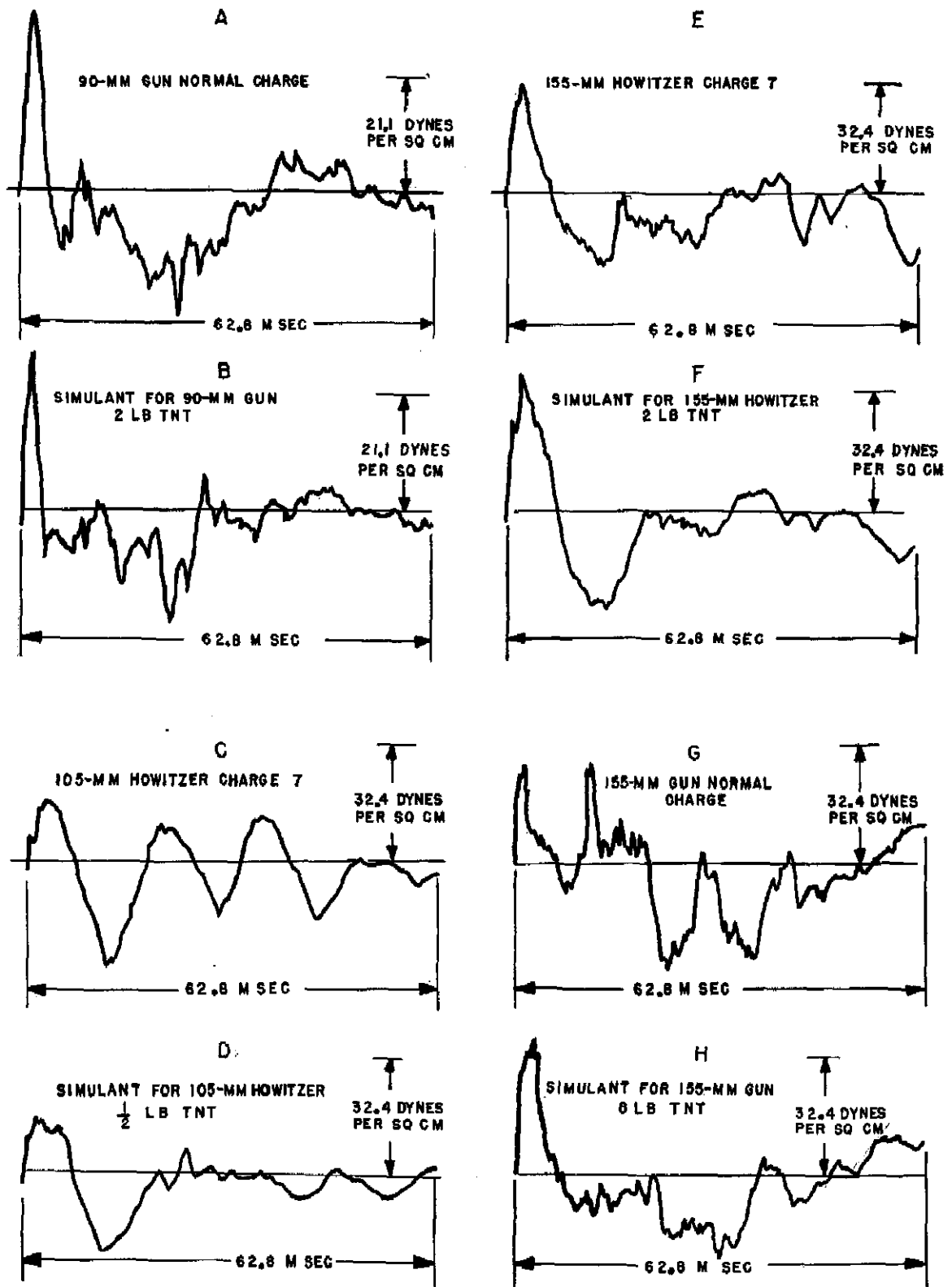

FIGURE 2. Oscillograms of field pieces and their simulants at 2,900 yd.

neutral pressure. At distances of the order of 1,500 ft nearly all the acoustic energy is in these first three pulses. At greater distances the pattern becomes more complex, as shown in Figure 2 taken at a distance of 2,900 yd. There is sometimes a rather irregular series of the secondary waves that fall off quite rapidly in intensity. The latter portions of the oscillograms may be much confused by echoes, reflections, and refractions of the original. At still greater

some impression of pitch and can usually say that one gun sounds "higher pitched" than another.

The total duration of a muzzle blast increases with distance from the source and with increased weight of the propellant. In general, the explosive sounds of guns ranging in caliber from 90 to 155 mm at a distance of 1,000 ft have a duration of approximately 30 milliseconds. At 2,900 yd the duration is of the order

TABLE 1

	Weight of propellant or simulant	Distance	Sound level meters (db)			db rms from oscilloscope
			GR 247	GR 623	ERPI 15	
.30-cal machine gun, single shots only Simulant	Army special cap and 6 in. Primacord	855 ft	54.0	51.0	71.0	
.50-cal machine gun, single shots only Simulant	Army special cap and 12 in. Primacord	855 ft	64.5	65.5	73.0	
60-mm mortar Simulants	0.01 to 0.1 lb ¼ lb dynamite, TNT, or 20 ft Primacord	1,003 ft	86.5	82.0	93.5	
81-mm mortar Simulants	0.1 to 0.5 lb ¼ lb dynamite, TNT, or 20 ft Primacord	1,003 ft	86.5	82.0	93.5	
90-mm gun Simulants	7.31 lb NH powder 2 lb TNT or 1½ lb C2	2,900 yd	69.0+	68.0	92.0	93.2
		2,900 yd	69.0—	68.0	91.5	90.5
105-mm howitzer Simulant	3.04 lb FHN powder ½ lb TNT	2,900 yd	81.5	78.5	95.5	94.5
		2,900 yd	79.5	79.0	95.0	92.3
155-mm howitzer Simulants	7.8 lb 2 lb TNT or 1½ lb C2	2,900 yd	81.5	82.0	91.0	94.5
		2,900 yd	82.0	84.5	93.5	96.7
155-mm gun Simulants	22 lb 8 lb TNT or 6 lb C2	2,900 yd	80.0—	82.0	96.5	95.86
		2,900 yd	78.5	80.5	97.5	95.9

distances, however, the wave becomes simplified due to the fact that high frequencies are attenuated more rapidly than the lows, causing the sound energy to approach a sine wave in form. The durations of the first two pulses also change with distance; both become longer as they proceed from the source.

The train of one positive, one negative, and another positive wave, all of different durations, is too brief and irregular to establish any clear impression of frequency, and the sense of pitch of gun sounds is therefore rather indeterminate. A listener does, however, obtain

of 60 milliseconds. However, an observer will hear echoes following a gun blast for periods ranging up to 0.5 second or more. Their duration is dependent upon the terrain, particularly upon echoing surfaces, and the rate of absorption. The echoes leave a marked impression on the observer as to the nature of the sound heard, probably because the duration of the echoes is long compared with that of the original blast. *Since the echoes are a function of terrain, the sound of the muzzle blast is, therefore, also a function of terrain as well as of the propellant and gun.*

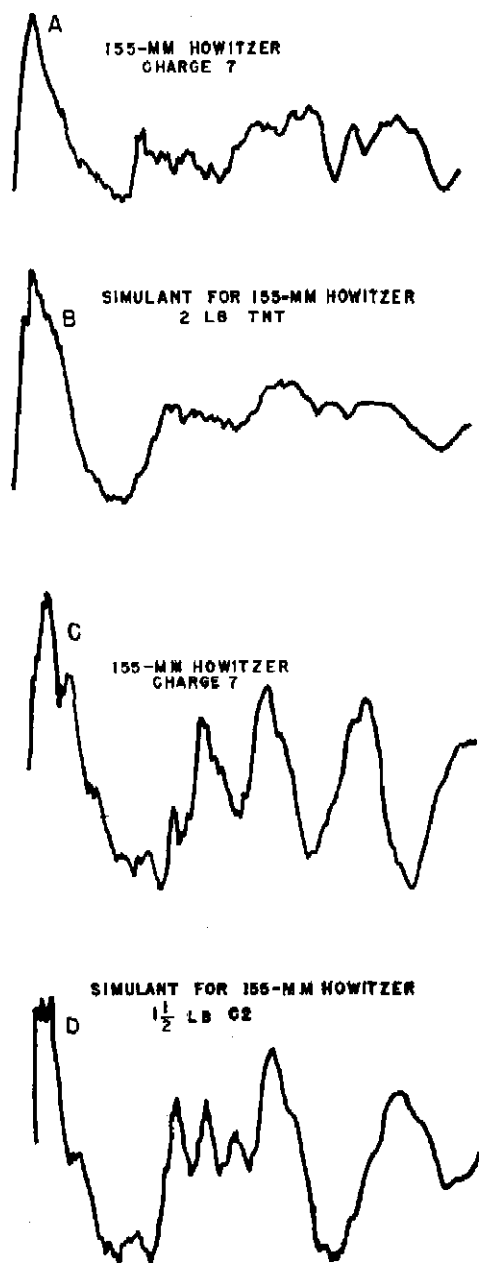

FIGURE 3. Two pressure waves *A* and *C* of muzzle sounds of 155-mm howitzers taken 15 minutes apart; also two pressure waves *B* and *D* of simulants, each taken within 5 seconds of the sound imitated. All measurements 2,900 yd from source.

12.1.2 Simulation of Single Shots: Wave Form

The transient character and high intensity of muzzle blasts make them very difficult to imitate by any mechanical or electroacoustic device. It was soon realized that by far the best

simulant of an explosive sound is another explosive sound. The sounds of various explosive simulants were, therefore, studied by means of oscillograms, sound level meters, and listening tests and compared with corresponding data concerning the sounds of muzzle blasts.

The simulants finally selected as most appropriate for various guns and field pieces are tabulated in Table 1. Each field piece and the weight of propellant employed is listed, together with the weight and nature of the explosive used as a simulant. Also listed are the intensities of both the muzzle blast and its simulant as recorded by three different sound level meters and also as determined from oscillograms. The measurements of noise level produced by explosive sounds differ systematically depending on the sound level meter employed. The two General Radio meters do not differ systematically one from the other, but the discrepancy between them and the Electrical Research Products, Inc. [ERPI] instrument was as much as 20 db on some waves. The discrepancy may be caused by differences in the overload characteristics of the amplifier and rectifier circuits, and by differences in the time constants of the circuits and, possibly, of the indicating instruments.

In most instances oscillograms of the muzzle blast and its simulant show striking similarity when the two are taken a few seconds apart. Figure 2 shows oscillograms of a 90-mm gun, 105-mm howitzer, 155-mm howitzer, and 155-mm gun paired with oscillograms of their simulants. All of these oscillograms were taken at a distance of 2,900 yd from the guns and simulants. The oscillogram of the simulant was taken within 5 seconds of that of the original. While there are plainly some variations between the original and the simulant, the similarities are certainly more impressive than the differences.

Figure 3 shows two oscillograms of a 155-mm howitzer taken 15 minutes apart, together with corresponding oscillograms of its simulants. The simulants were photographed in each instance within a few seconds of the original. It is apparent that the simulant is more like the original in each case than the two originals are like each other.

These observations indicate that sound undergoes marked changes in transmission, that the conditions which affect transmission vary through wide limits in a very few minutes, and that any given set of conditions influence the sound of the guns and of the simulants in much the same manner.

12.1.3 Simulation of Single Shots: Intensity

It is, therefore, clear that simulation of muzzle blast by other explosions is satisfactory as to wave form. Simulation in regard to intensity is equally satisfactory, largely because there is no fixed value of intensity which must be closely matched. Most field pieces are supplied with several propellants differing in weight and therefore in the intensity of their muzzle blast. Each piece has therefore not one, but several intensities of blast which are typical, and, even when a charge of given size is fired by a given field piece at a given location and an auditor listens at a fixed location at some distance, the sound which reaches him varies from shot to shot due to variations in the transmission characteristics of the atmosphere. Each small change in density of the air, which is stirred by many gusts of wind, offers a variation in reflection and refraction. Oscillograms taken of a field piece at various times at a given location show quite marked differences not only in wave form but also in intensity. The imitation of gun sounds is not a problem of imitating a constant sound but rather a sound which varies within rather wide limits of intensity and wave form. It is, therefore, understandable why simulants give most impressive imitations of explosive sounds whereas some other sounds, particularly speech, have been found most difficult to duplicate.

The sound of gun fire can be successfully imitated by the use of nitrostarch, Primacord, dynamite, TNT, or C2. In general, the weight of the simulant required is about a quarter to a half the weight of the propellant due to the fact that much of the energy of the propellant is absorbed in accelerating the projectile. Equivalent weights of the above explosives for generating acoustic power are given in reference 1a.

12.1.4 Listening Tests

Listening tests conducted by trained personnel indicate that the ear cannot detect the difference between the muzzle blasts of the various field pieces and the appropriate simulants selected.

The simulant for a .50-caliber gun has been tested with particular care. Thousands of rounds were fired in the presence of several hundred Army observers. Even trained observers failed to detect any difference between actual machine gun fire and its simulant. It was the consensus that the sounds produced by Primacord are fully authentic and so similar to actual gun sounds that detection of any difference by ear is quite impossible.

12.1.5 Detection by Sound-Ranging Equipment

Although the similarity between the sounds of a muzzle blast and of its simulant is entirely satisfactory over most of the audio range, differences occur in the low-frequency range for 90-mm guns and pieces of larger caliber, of sufficient intensity to be detected by Army sound-ranging equipment. The difference permitted the observer to distinguish successfully between the simulant and the actual gun under the circumstances of the test, i.e., when gun and simulant were fired at the same place. If variations in distance and complications due to multiple firing were introduced, however, it is doubtful whether or not consistent detection could be made.

An important distinction should be made, nevertheless, between the sound of the muzzle blast of a field piece and the entire sound of the field piece which consists of the muzzle blast, the projectile sound, and the burst of the shell. In the case of heavy field pieces, deception can succeed only when the simulants are used in connection with real pieces. Projectile sounds and shell bursts in enemy territory must add their necessary realism in order to deceive. If some of these additional sounds are provided, however, and if the usual care and skill necessary in most deceptive efforts are exercised, it should at least be possible to deceive the enemy

as to the number of field pieces present. The simulants may also serve to confuse the operators of sound-ranging equipment and thereby diversify the enemy's return fire.

12.1.6 Simulation of Machine Gun Fire

Imitation of the sound of machine guns requires not only successful duplication of the sound of a single shot but also duplication of the rate and regularity of fire of an actual weapon. The appropriate timing of the explosions of successive charges of the simulant has been obtained by detonating the charges of Primacord by electric caps attached to a timer made from a telephone dial and energized by a dry cell. The telephone dial is set with its dial turned as far as possible in the clockwise direction and retained in this position by a piece of fuze. When this fuze is ignited, either by means of a slower timing fuze or by electric control, the dial is released and fires the ten charges of Primacord in rapid succession as it returns to its home position.

The individual charges are mounted on a stick to keep them sufficiently separated one from another and thus avoid interaction between them. These devices may be fired from the ground or dropped on a small parachute from an airplane. Figure 4 is a photograph of such a machine gun simulator. The complete details and instructions for making and using this device are contained in reference 1b.

12.1.7

Desultory Rifle Fire

The original objective of the Navy was to secure a device which would simulate desultory rifle fire over a period of 10 minutes. To provide this distribution in time, four packages each containing 25 individual charges of the appropriate length of Primacord were formed into a single larger package to be thrown from an airplane. When the large package is thrown from the plane, its outside wrapper is torn off by the rip cord. A pull-wire lighter ignites the fuzes of the various unit packages and also opens four small parachutes, one for each of the small

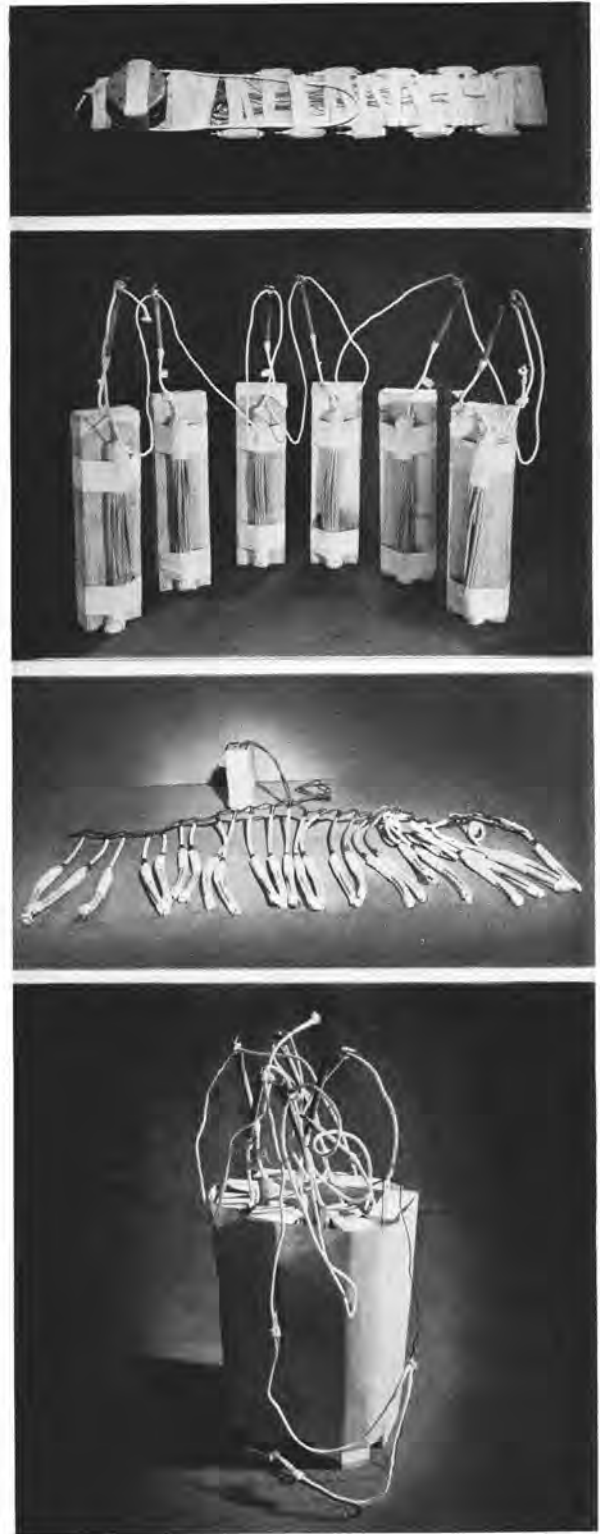

FIGURE 4. Machine gun simulator.

packages. The four units float to the ground, and the various charges detonate at intervals determined by the lengths of their respective fuzes. Each package is timed with an appropriate length of fuze, the fuze lengths differing so as to cause the packages to begin firing in 10 seconds, 2½ minutes, 5 minutes, and 7½ minutes respectively after they have been dropped from the plane. In each of the smaller packages the 25 lengths of Primacord are mounted around a spreader charge. The spreader charge is timed to fire first. When it explodes, it scatters the 25 rounds of Primacord over an area approximately 50 ft in diameter. The fuze of each round is ignited before the spreader charge explodes, and each charge detonates when the fire in the fuze reaches its cap. The fuzes of each unit package are cut to various lengths to provide desultory fire over a period of 2½ minutes.

Full details and instructions for the manufacture and for the operation of this device are also completely described in reference 1b.

12.1.8 Simulation of Mortar Fire

In Table 1 it will be observed there is a wide range of simulators for 60- and 81-mm mortars. The variety corresponds to the different weights of the propellant used in these mortars.

Reference 1b also describes complete details for making and using a package that will simulate six rounds of mortar fire. This package is suitable for dropping from the air without a parachute. The timing of the explosion of the successive charges is determined by the length of the fuze attached to each. When the package is thrown from the plane, the cover is ripped open by the static cord. The six fuzes are ignited by pull-wire lighters, and the charges fall separately to the ground. The timing of the shots has been made to simulate to some degree the timing of the mortar fire. The package described^{1b} is timed to fire its charges at approximately 10, 13, 16, 17, 18, and 19 seconds respectively after dropping from the plane. The timing can, of course, be changed as desired, simply by changing the lengths of the fuzes.

12.1.9 Simulation of Larger Field Pieces

Table 1 gives the weight and kind of simulants for the 90-mm gun, the 105-mm howitzer, the 155-mm howitzer, and the 155-mm gun. If TNT or C2 is not available, appropriate weights of dynamite or nitrostarch may be substituted in amounts indicated in reference 1a. It is intended that simulants for these large field pieces be fired individually, probably coordinated with the fire of actual field pieces. There is no special problem of timing corresponding to the timing of machine gun fire or mortar fire.

The simulation of small arms and of the muzzle blasts of artillery fire by means of the explosion of charges of appropriate weights of nitrostarch, TNT, dynamite, Primacord, or C2 may be considered entirely satisfactory as far as pure acoustic imitation is concerned, acoustic simulation being easy and complete (except as against sound-ranging equipment sensitive to very low and subaudible frequencies). A weight of high explosive equal to about one-half or one-third the weight of the propellant is quite adequate, and its effectiveness is not critically dependent on the choice of explosive. It is recognized, however, that any simulation to be fully effective must be complete and consistent. Visual as well as acoustic aspects must be considered also, and the final choice of explosive should be based on appropriate simulation of flash and smoke as well as of sound.

12.2 SIMULATION OF MOTOR SOUNDS: "CANARY"

The "Canary"^{1c} consists of two small out-board motors each equipped with an acoustic horn. The two are operated together at slightly different speeds to give a beat note of low frequency. The sound of the Canary may be employed for deceptive purposes, with a range of 2 to 4 miles over land and considerably more over water. It has been variously pronounced to sound like airplanes, tanks, or steam shovels. The Canary is also particularly effective as a masking device to obscure the sounds of military vehicles.

12.2.1

Description

The motors used in both the experimental and field model Canaries were Johnson outboard type POLR-15 of 22 hp. Each has two cylinders in opposed relation, both of which fire simultaneously in order to attain the greatest acoustic intensity.

A horn is attached to the two exhausts of each motor. Each horn has two throats as

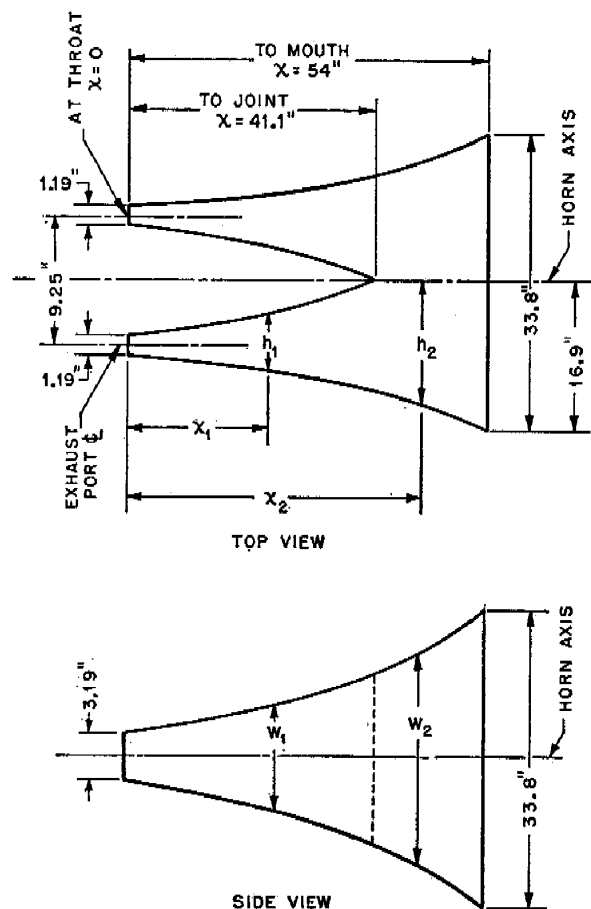

FIGURE 5. Diagram of Canary horns.

shown in Figure 5. The horn was designed for a theoretical cutoff of 100 c. It is exponential in expansion rate and rectangular in cross section. It is 54 in. long, the total area at the throat being 7.57 sq in. and the total area at the mouth being 1,142 sq in.

The experimental models of the Canaries were mounted on water tanks and operated with their propellers in the water, to provide an

appropriate load. In the field model shown in Figure 6 the propellers and their driving rods were removed and replaced with hydraulic brakes.

The brake is bolted to the motor head. The diameter of the rotor is 5 in., and the inside diameter of the stator is 5½ in. Five blades are attached to each face of the rotor and four to each face of the stator. The brake absorbs 22 hp at 4,000 rpm.^a

Cooling is provided by radiators of tubular fin construction 15 in. wide, 17 in. long, and 6 in. deep. The total area is 12,240 sq in. for each motor. Cooling water is circulated by the hydraulic brake. Air is delivered by a blower wheel driven by an extension of the brake shaft through a 10 to 7 gear reduction. The blower wheel (manufactured by the Torrington Manufacturing Co.) has a capacity of 2,400 cu ft per minute at 2,500 rpm.

The weight of the field model, exclusive of the carrier, is 800 lb, consisting of two units of 300 lb each and a pivot and frame weighing 200 lb. The weight of each unit is made up as follows:

Motor head and fuel tank, dry	65½ lb
Brake, dry	21 lb
Radiator, dry	60 lb
Horn	123 lb
Fuel	15 lb
Water	15½ lb
Total	300 lb

The field model is satisfactorily mounted on the bed of a light truck.

12.2.2

Operation

The motor governors do not regulate the speeds of the motors with complete constancy, and consequently they vary in speed between narrow limits. These variations of speed are sufficient to generate a continually changing beat note which imparts an interest-compelling character to the sound and greatly improves its abilities to mask the sound of vehicles. The characteristic "putt-putt" of the outboard

^a It is anticipated that the details of design of this hydraulic dynamometer, developed for this project, will be cleared and published in an appropriate technical journal. It is, therefore, unnecessary to present further details here.

motor is no longer obvious to a listener. Since the high frequencies are attenuated with transmission more rapidly than the lows, the low frequencies increasingly predominate with increase in distance.

A wide variety of modifications of the sound of the Canary may be obtained: (1) by using a chopper rotating in front of the horn or at a point between the throat and the mouth of the horn; (2) by means of a "butterfly," a rectangular hole cut in the side of the horn at a point 1 or 2 ft from the horn throat and equipped with a flat metal plate that rotates to alternately



FIGURE 6. Canary: field model.

open and close the opening; (3) by variations in the absolute speeds of the motors; and (4) changes in the direction of the beam.

Both the chopper and the butterfly serve to modulate the intensity by 6 or 8 db, but neither feature was incorporated in the field model. One limitation on the manual operation of any such modulations lies in the necessity of carrying them out with an accuracy consistent with the gradual changes of speed of a large machine. When used for deceptive purposes, the Canary suggests a large machine because of the presence of the low-frequency beat, and any modulation must be consistent with this illusion. Manual control should therefore be attempted only by practiced personnel with a high sense of rhythm and timing. It is anticipated that the chief modification in practice will be in the direction of the beam which automatically

changes the intensity of sound delivered to any particular distant point.

12.2.3

Acoustic Performance

The pressure level of a Canary (two motors) is 123 db at 100 ft in front of the horns. Figure

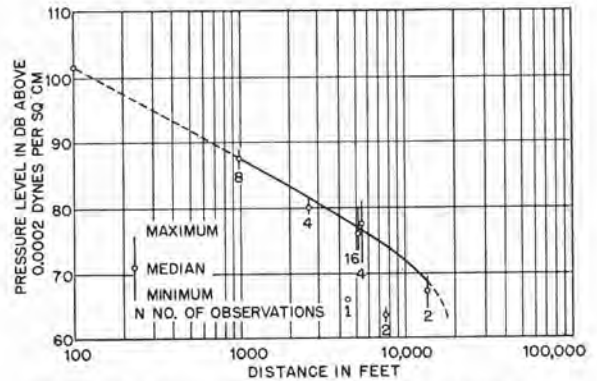

FIGURE 7. Sound transmission of Canary over thick grass 18 in. high, occasional trees. Data taken under both day and night conditions over a period of several weeks.

7 shows the relation between pressure level and distance over land. The measurements were taken over a period of several months under varying but unclassified weather conditions.

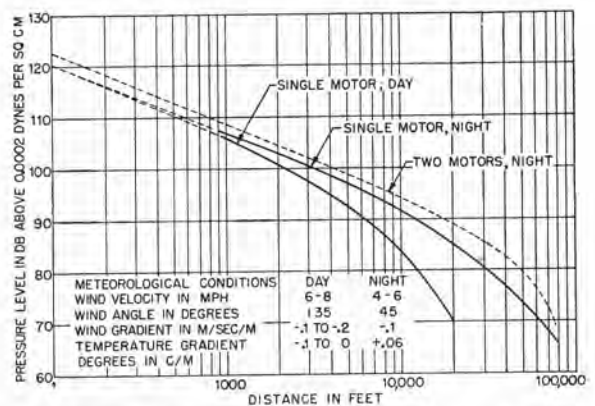

FIGURE 8. Sound transmission of Canary over water.

Figure 8 shows the relation between pressure level and distance over water at night. Figure 9 shows the frequency distribution of the acoustic energy of a single motor between 60 and 900 c.

The pressure level varies by 10 db as the

speed of the motor is increased from its normal speed range from 2,400 to 4,200 rpm. At high speeds one motor sounds somewhat like a siren.

The attenuation of Canary sounds transmitted over sandy soil with thick grass in the daytime is approximately 9 db per distance doubled. In normal weather conditions the deceptive quality is best at between 2 and 4 miles over land and between 3 and 15 miles over water. Deception is most effective when the

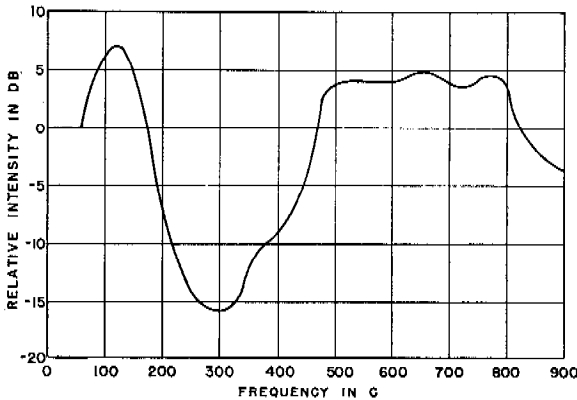

FIGURE 9. Single motor of Canary. Portion of frequency spectrum between 70 and 900 c.

sound can be distinctly heard through ambient noises but not with sufficient loudness to give a clear impression of the character of the sound.

12.3 THE SOUND SCREEN: MASKING THE SOUNDS OF MILITARY VEHICLES

It is often desirable to conceal from the enemy the movement of military vehicles such as tanks, trucks, and personnel carriers. Visual detection may be prevented by taking advantage of favorable features of terrain, such as hills or embankments, by the use of smoke screens, or by carrying out the movement under cover of darkness. But, although the vehicles are no longer visible, they remain audible, and the present problem is to devise a means of preventing detection of the sounds of military movement or action. The objective is accomplished by providing a sound screen, that is, another sound that masks the sound of the vehicles, rendering them inaudible just as a smoke screen renders them invisible.

The Canary, originally developed as a deceptive sound source, and the Bell Telephone Laboratories' [BTL] siren both proved to be practical means of generating such a sound screen. Their effectiveness was tested experimentally, and an analysis was made of acoustic data to determine the character, number, and position of the masking devices required to conceal any given movement of a specified group of vehicles.^{1d}

12.3.1 Sound of Moving Vehicles

Measurements were made of the intensity and the frequency spectrum of the sounds of the following Army tanks: M3A1, M3A5, M4A1, M4A3, M5A1, and M10, and also of the 2½-ton truck and the 1½-ton personnel carrier. The intensity varies 4 to 9 db with the azimuth of the observer and is usually loudest directly behind. Ninety to 95 per cent of the energy lies between 65 and 300 c. It is the exhaust sounds, particularly at distances of ½ mile or greater, that usually determine the amount of masking noise

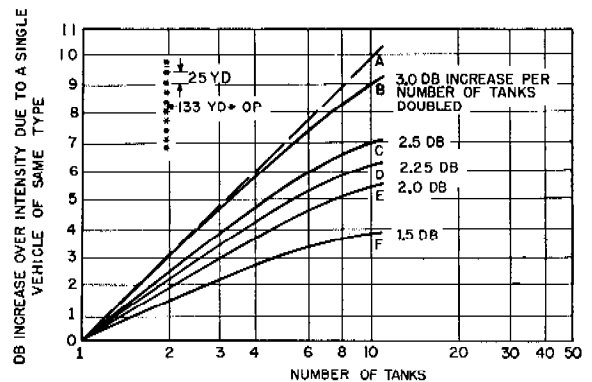

FIGURE 10. Increase in the intensity at the observation post due to the sound of N vehicles, arranged as shown in sketch, over the intensity due to a single vehicle at 133 yd. Based on: 9 db loss per distance to vehicles doubled.

required to prevent the detection and recognition of tank sounds. At shorter distances the track noises are sometimes prominent. The addition of more efficient mufflers would greatly facilitate masking and improve the chances of successful surprise attack.

At 100 ft the pressure level of the sounds from the above vehicles varies between 80 and

108 db for the various tanks and between 70 and 85 for the trucks. The intensity varies, of course, with the type of motor, the horsepower, the exhaust system, and also the motor speed and load.

12.3.2 Sound Intensity of Groups of Vehicles

The pressure level for an M3A1 tank operated at a distance of 133 yd was observed to be 81 db. If two tanks were operated at this same distance, the theoretical pressure level at the observation post would be 84 db or an increase of 3 db; with four tanks the pressure level

inverse square law which corresponds to a 6-db loss per distance doubled, but an observed loss of 9 db per distance doubled. The exact value depends on the terrain, meteorological conditions, and frequency spectrum of the sound under observation. Curves C, D, E, and F of Figure 10 are plotted with a loss of 9 db per distance doubled, but with various assumed increases of intensity per number of vehicles doubled, as indicated on the respective curves.

The curve in Figure 11 has been plotted to conform with an increase in intensity of 2.25 db per number of tanks doubled and 9 db decrease per distance doubled, and is therefore identical with curve D of Figure 10. This curve shows reasonable agreement with the points plotted from measurements.

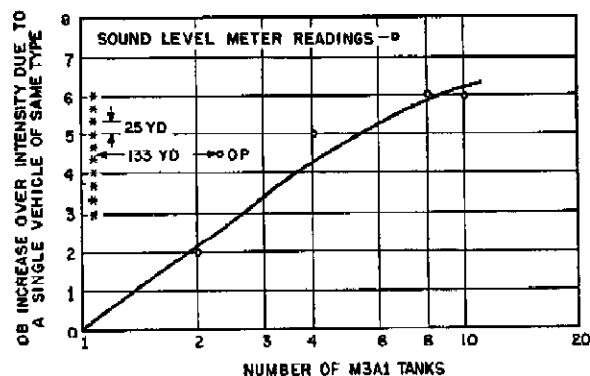

FIGURE 11. Increase in the intensity at the observation post due to the sound of N vehicles, arranged as shown in sketch, over the intensity due to a single vehicle at 133 yd. Based on: 9 db loss per distance to vehicles doubled; 2.25 db gain per number of vehicles doubled.

would be 87 or an increase of 6 db. Each time the number of tanks doubles, the intensity theoretically increases 3 db as shown in curve A, Figure 10. Curve B shows the theoretical maximum intensity at the observation post from a number of tanks spaced at 25 yd apart traveling in a line at right angles to the observation post, the shortest distance from the operating post to the line being 133 yd. Owing to the fact that the tanks on either side of the nearest one are progressively more distant from the observation post, curve B shows a diminishing rate of increase of intensity as the number of tanks increases.

The assumed loss of intensity with increase in distance noted on Figure 10 is not the familiar

12.3.3 Principles of Masking

To avoid destruction from gun fire, masking devices must of necessity be located at a distance of several hundred yards from the enemy. The high frequencies of a complex sound are attenuated more rapidly than the low frequencies with distance. As a sound approaches threshold due to distance only the low frequencies remain. For this reason, and because the energy content of the sounds of vehicles is small in the high frequencies, the problem of masking Army vehicles at a distance becomes largely one of masking the low frequencies.

One sound can mask another only when it is of greater intensity. The greater the difference in frequency between the two sounds, the more must the intensity of the masking sound exceed that of the masked sound.

The nearer the pattern of the masking sound approaches that of the sound to be masked, the more difficult it is to detect the latter. For these reasons it is desirable that a masking sound be similar in pattern to the sound masked and equal or lower in frequency. If the noise to be masked is not steady but, like the sound of motors and vehicles, has a fairly regular and characteristic temporal sequence or pattern, imitating the temporal pattern as well as the frequency pattern by the masking sound makes it more effective as a masker.

12.3.4

BTL Siren

The BTL siren used in the work differs from that described in reference 2 in that it is equipped with a horn designed for a theoretical cutoff frequency of 75 c. It develops a sound in-



FIGURE 12. Oscillogram of BTL siren. One cycle of a repeating wave. Fundamental frequency: 470 c; azimuth: 0 degree; distance: 1,000 ft.

tensity of 133 db at 100 ft. The fundamental frequency can be varied between 60 and 500 c. The siren consists of an air compressor, a compressed air chamber fitted with six port holes



FIGURE 13. Oscillogram of BTL siren. One cycle of a repeating wave. Fundamental frequency: 230 c; azimuth: 0 degree; distance: 1,000 ft.

arranged in a circle, a chopper consisting of a disk with six extensions each of which covers a respective port, means for rotating the chopper to open and close the ports, and a multiple horn

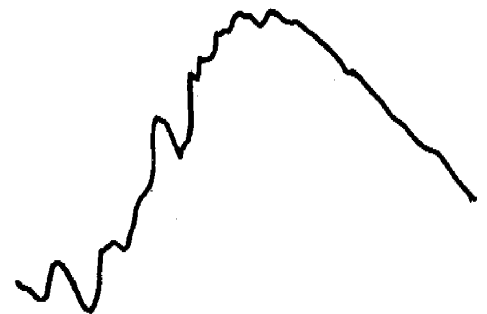

FIGURE 14. Oscillogram of BTL siren. One cycle of a repeating wave. Fundamental frequency: 115 c; azimuth: 0 degree; distance: 1,000 ft.

into which the ports exhaust. The fundamental frequency is determined by the speed of the chopper.

Figures 12, 13, and 14 are oscillograms of the wave form of the siren at chopper speeds of 4,700, 2,300, and 1,150 rpm respectively, corresponding to fundamental sound frequencies of



FIGURE 15. Oscillogram of single Canary motor. One cycle of a repeating wave. Fundamental frequency: 71 c; azimuth: 0 degree; distance: 1,000 ft.

470, 230, and 115 c. The tracings as shown in Figures 12 and 14 cover less than a complete cycle.

The siren is well adapted to mask the sound of Army vehicles because of its great intensity



FIGURE 16. Oscillogram of single Canary motor. One cycle of a repeating wave. Fundamental frequency: 60 c; azimuth: 0 degree; distance: 1,000 ft.

and the fact that its harmonic content is reasonably similar to that of Army vehicles. Its variable fundamental frequency allows for adjustment to an optimum frequency for masking a given sound.



FIGURE 17. Oscillogram of single Canary motor. One cycle of a repeating wave. Fundamental frequency: 33 c; azimuth: 0 degree; distance: 1,000 ft.

12.3.5

Canary

The construction and performance of the Canary have been described in Section 12.2. It

produces a sound intensity of 123 db at 100 ft. Wave forms of a single Canary motor at speeds of 71, 60, and 33 c are shown in Figures 15, 16, and 17. By operating the two motors at slightly different speeds, beat notes of almost any desired low frequency are developed.

The Canary is suitable as a masking device, not only because it has a fairly high intensity, but also because it has a sound pattern resembling that of motor vehicles. For this reason, it requires a smaller intensity differential to mask vehicle sounds than is required of dissimilar sounds.

12.3.6 Observations and Conclusions

Over 200 determinations were made of the distance (over flat, grassy terrain) at which the sounds of Army vehicles (M4A3 tanks, M3A1, and 2½-ton trucks) were masked by either a BTL siren or a Stevens Institute Canary.

Both devices proved to be very effective as maskers and about equivalent to one another. Either one can mask the sound of a formation of 17 M4A3 tanks moving in normal formation if it is as close to the enemy outpost as the nearest tank. If more maskers are used, they may be placed at greater distances from the enemy. For example, 17 M4A3 tanks in a column approaching an observation post can be masked with reasonable certainty to within 700 yd of the post by the following combinations:

<i>Number of maskers</i>	<i>Distance of maskers</i>
8	1,220 yd
6	1,135 yd
4	1,005 yd
2	830 yd
1	700 yd

Trucks are easier to mask than tanks. *A Canary a mile away can on the average mask two 2½-ton trucks to within 150 yd of an observation post.* The Canary is slightly more effective than the siren for masking trucks.

The distance at which vehicles may be successfully masked is directly proportional to the distance of the masker. The ratio does not change significantly as the distance of the

masker is increased, except that at some outer limit (approximately 2 miles) the intensity of the masker is so low that it may fail completely to mask the vehicles, its influence being small compared with that of the background noises. At this distance, also, transmission variations due to variations in meteorological conditions are so great as to render specific conclusions impossible.

The distance at which masking of a given pair of vehicles occurs on repeated trials with a masker at constant distance varies from about half to about double the median distance. The chief cause of the variations is fluctuation of the velocity and direction of the wind. An adequate study of the relation between effectiveness of masking and meteorological conditions would require an estimated 2,000 observations in the field. Such a study should be made and should be extended to cover several varieties of terrain and a wider range of wind velocity. Almost all the *present study covers only grassy terrain* and the moderate winds of fair spring and summer weather at Pine Camp, New York.

The theoretical principles have been derived, and are supported by preliminary experiments, for calculating the number and distances of maskers required to mask any number of vehicles traveling in their usual formations to within any specified distance of the enemy. The accuracy of such predictions and the allowance that must be made to insure against failure due to momentary variations of acoustic transmission are both improved by taking into account the expected wind and temperature conditions. The method of solution of a typical problem is illustrated in reference 1d, and it is pointed out that tables and graphs can be constructed which would make it quite simple to determine the number and position of masking devices required to mask the sounds of the movement of any group of Army vehicles. It is also shown, however, that, owing to the vagaries of sound transmission over considerable distances, it is impossible to insure continuous masking with absolute certainty without profligate use of maskers at short range. It is possible, however, to calculate a more reasonable use of maskers that will insure masking to various degrees of certainty, such as 50 per cent, 80 per cent, or



95 per cent. Several psychological factors, such as the uncertainty of enemy observers as to the time at which to listen most carefully for the sounds of the vehicles and their uncertainty as to just what kind of sound to listen for, will undoubtedly tend to make masking more successful than it was under the experimental conditions.

Chapter 13

MOBILE LOUDSPEAKING SYSTEMS FOR DECEPTION AND DECOY

13.1 SOUND TRANSMISSION AND RECEPTION

THE SOUND LEVEL received at the enemy's position is of vital importance to successful deception. If the sound is too loud, there is greatly increased possibility that it will be recognized as a recording, while, if it is too low, it will not be heard at all. No quantitative data were available on the best deceptive level or upon the transmission loss that must be anticipated between a sound source and a distant listening position. An investigation was therefore undertaken to supply such data for transmission over land, the work being done at the Army Experimental Station [AES], Sandy Hook, between September 1, 1943 and January 31, 1944, as a part of Project 17.3-4.1.¹

The principal factors to be investigated were:

1. The intensity and character of the sound at the source;
2. The transmission loss between the source and the listening position; and
3. The masking noise at the listening position.

The first of these is controlled by the frequency spectrum of the particular sound being used and by the characteristics of the reproducing equipment. The transmission loss is a complex function of frequency, distance, atmospheric conditions, and type of terrain. The masking noise varies widely from time to time. It does, however, have a reasonably stable minimum value which happens to be of particular interest in sound deception.

13.1.1 Sound Source

SOUND RECORDINGS

The solution of technical problems associated with the recording program constituted a substantial part of the assistance rendered to the Army Experimental Station under NDRC auspices.

The possibility of using recordings obtained

from commercial sound libraries (motion picture and broadcast sound effects) was considered, but such recordings do not offer an adequate variety of sounds. Trained observers can recognize, with varying degrees of certainty, not only vehicle types (particularly tanks) but whether vehicles are ascending or descending a hill, whether they are head on or broadside, and whether their engines are idling or driving the vehicles at slow speed. It is, therefore, essential that sounds be recorded in all their variations for all important types of military vehicles.

Practically all commercial recordings of vehicle sounds are recorded close up. Pronounced doppler effects characterize sounds recorded in this way. Their use in an attempt to create an illusion a mile away is obviously ineffective.

In making original recordings for sonic deception, new techniques were developed. One example consists of locating the microphone pickup at the center of a circle of continuously moving vehicles. In this way, the collective sound of motor vehicles of the required type and number is obtained continuously and at high level, free of the revealing doppler effect.

Another technique is the exaggeration of incidental telltale sounds, such as the squeak of tank caterpillar treads. It is known that an observer strains to recognize these sounds. These can be accentuated by superposing them on an otherwise ordinary sound.

The recording work was done both at Fort Hancock and Pine Camp, New York, a specially equipped truck and trailer being used for this purpose. The recorded material covers a large variety of military vehicles including tanks, and many other sounds of military interest, such as bridge building and field construction work.

When a sound record is dubbed on a magnetic recorder and played back through an amplifier and loudspeaker, the frequency spectrum of the radiated sound will differ from that of the original record by the addition of the frequency characteristics of the magnetic recorder and of

the reproducing equipment. However, the differences between the spectra of the original and the reproduced sounds lose some of their significance under practical conditions of use, as will be illustrated later.

13.1.2

Sound Transmission

METEOROLOGICAL CONDITIONS

The weather has a great influence on sound transmission, and a knowledge of local atmospheric conditions is necessary for either an analysis of sound level data or for the anticipation of transmission loss that may prevail at some particular time. The detailed information

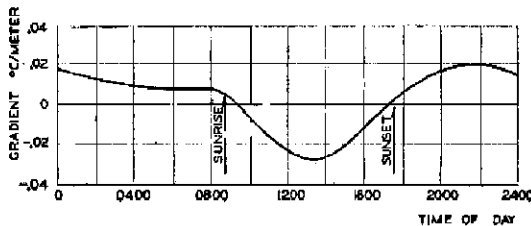

FIGURE 1. Temperature gradient, elevation 5 to 35 ft.

needed is the humidity, the wind velocity and direction, and the vertical gradients of wind velocity and of temperature. The horizontal gradients and the temperature may be neglected since they have no important effect on transmission. The wind velocity gradient is defined

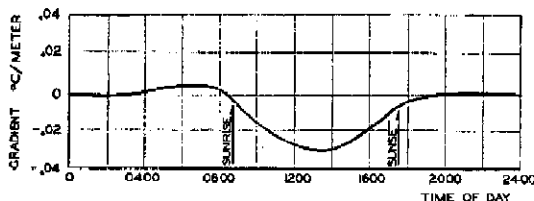

FIGURE 2. Temperature gradient, elevation 35 to 95 ft.

as the change in velocity with elevation. It is measured in meters per second per meter and is almost always positive, i.e., the velocity increases with elevation. The temperature gradient is the rate of change of temperature with elevation and is measured in degrees centigrade per meter. It may be either positive or negative,

a positive gradient indicating an increase in temperature with height.

A rather extensive series of meteorological measurements were made at Sandy Hook. Readings were made at elevations of 5, 35, 65, and 95 ft. The temperature and velocity gradients were computed. Check measurements showed that the temperature conditions were stable

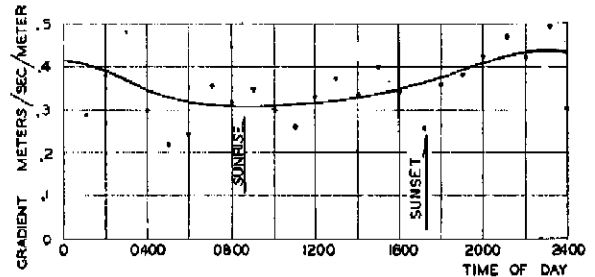

FIGURE 3. Wind gradient, elevation 5 to 35 ft.

over wide areas but that the wind conditions were not. Portable equipment was obtained and wind measurements made at each listening point simultaneously with the sound measurement. These supplementary data were confined to elevations of 5 ft and 15 ft. The data obtained at the time of sound measurements were useful

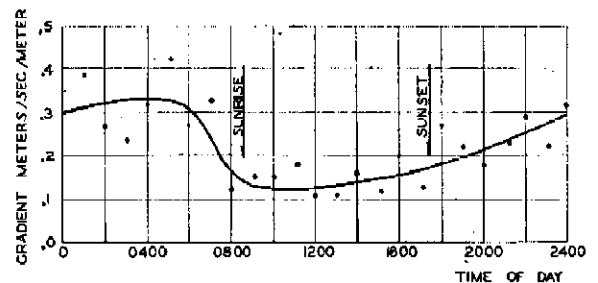

FIGURE 4. Wind gradient, elevation 35 to 95 ft.

in the analysis of those measurements but were not adequate for predicting future conditions.

Average hourly temperature gradients between elevations of 5 ft and 35 ft, and of 35 ft and 95 ft are shown in Figures 1 and 2. The outstanding feature of the curves is that the gradients become negative at sunrise and remain negative until sunset, both the 5 to 35 and 35 to 95 ft gradients reaching a value of about -0.030 C per m in the middle of the day. At night, the average gradient is positive (about $+0.010$) near the ground but is zero in the 35- to 95-ft region. Individual readings vary widely

from the average, a range of +0.70 to -1.00 having been recorded during the daytime.

Similar curves of wind gradients are shown in Figures 3 and 4. The average values range from 0.20 to 0.50 m per sec per m near the ground and from 0.10 to 0.40 m per sec per m in the 35- to 95-ft region. The gradients are lower during the day than at night, but the sun has not nearly as pronounced an effect on the wind as on the temperature. The individual readings again varied greatly as is evidenced by the scattering of the average values. A range of -0.10 to +1.00 m per sec per m was recorded.

Since gradients are small differences between large numbers and require precision instruments for their accurate measurement, it would be convenient to correlate them with some more easily measured quantity. The relation of wind gradient to wind velocity was, therefore, determined for this group of data. The curve of the average values follows the equation:

$$w = 0.017W^{1.5},$$

where w is the wind gradient and W the wind velocity. Limit curves (Figure 5) are drawn to include most of the individual values. In general, the gradient at Sandy Hook may be expected to be within ± 0.20 of the value given by the equation.

PHYSICAL CHARACTERISTICS OF SOUND PROPAGATION

A sound wave traveling through the air toward a distant point will arrive with a greatly reduced intensity. The loss is due principally to four causes: dispersion, refraction, absorption by the air, and absorption by the surface over which the sound may be traveling.

The dispersion loss is due to the sound wave having a constantly expanding spherical wave front. Its energy must, therefore, be distributed over an increasingly large area as it progresses, and the energy per unit area (intensity) is correspondingly reduced. This dispersion loss between two points distant D_1 and D_2 from the source is

$$L_1 = \text{Loss in db} = 20 \log \frac{D_1}{D_2}.$$

It amounts to 6 db every time the distance is doubled.

In a homogeneous medium the sound rays travel in straight lines radiating from the source, but in a nonhomogeneous medium these rays will be bent by refraction. This is of interest in the present problem because most of the energy from a large loudspeaker is confined to a narrow cone and refraction may prevent centering this sound cone on the enemy's position.

The temperature gradient is one source of refraction because the velocity of sound is a function of the temperature and a change of temperature with elevation will cause different parts of the sound wave to travel with different speeds. If the temperature gradient is positive,

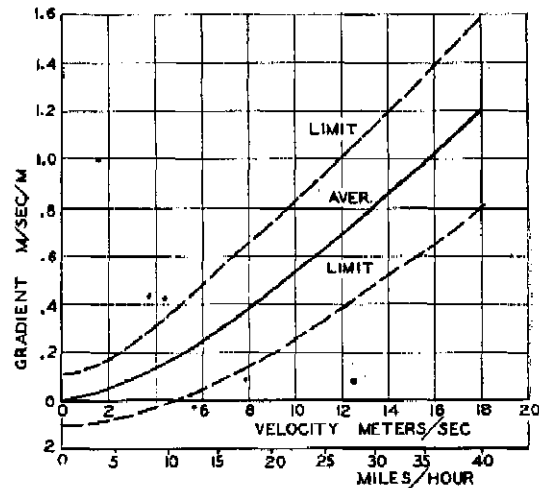

FIGURE 5. Wind gradient versus wind velocity.

the portion of the wave front near the ground will be cooler and, therefore, will travel more slowly than the upper portion. This will cause the rays to be curved downward. Conversely, if the gradient is negative, the rays will be bent upward.

A similar bending is caused by the wind velocity gradient. This is because the sound wave velocity is the vectorial sum of sound and wind velocities. A following wind will thus increase the wave velocity, and an opposing wind will decrease it. This, by itself, would not bend the sound rays, but the wind velocity is always less near the ground than at higher elevations (positive gradient), making the wind effects less pronounced on the lower portion of the wave. This results in the rays being bent downward by a

following wind and upward by an opposing wind.

The wind factor is usually considerably greater than the temperature factor. For example, a tail wind of 2 miles per hour will almost neutralize the normal midday temperature gradient of -0.025 C per m.

The paths of refracted sound waves are shown diagrammatically in Figures 6 and 7. In



FIGURE 6. Refraction effects with negative curvature.

Figure 6 waves with negative curvatures are illustrated. Under this condition, the sound literally bounces along the ground as it travels from source to listening point. Figure 7 illustrates positive curvature. Here the sound curves upward so that beyond a certain point, designated A, the simplified theory indicates that it is impossible to transmit sound from the source to a listening point at the ground level. However, refraction is always accompanied by some reflection, and also, under practical conditions, there are always eddy currents and other

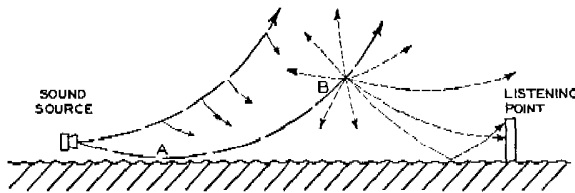

FIGURE 7. Refraction effects with positive curvature.

discontinuities in the air that tend to scatter the sound ray. This reflected and scattered sound energy will cover a large area and some of it will reach listening points beyond A. An eddy with attendant secondary sound rays is illustrated at B. It is readily apparent that transmission under these conditions will be greatly inferior to that when a negative curvature prevails.

Absorption in air, the third factor in transmission loss, causes a reduction in sound inten-

sity by converting sound energy into heat. It is a function of relative humidity, temperature, frequency, and distance. As humidity is an important variable, it is convenient to refer to this as humidity loss. The change in intensity, caused by this absorption, is expressed by the equation

$$I_d = I_0 e^{-md}$$

where I_0 is the intensity at the source, I_d is the intensity at distance d feet from the source, and m is an absorption coefficient. This equation may be changed to the form

$$L_2 = 4.34md,$$

where L_2 is the humidity loss in db. This equation shows that this loss varies directly with distance. At frequencies below 1,000 c, the loss is less than 2 db per 1,000 ft, but at high fre-

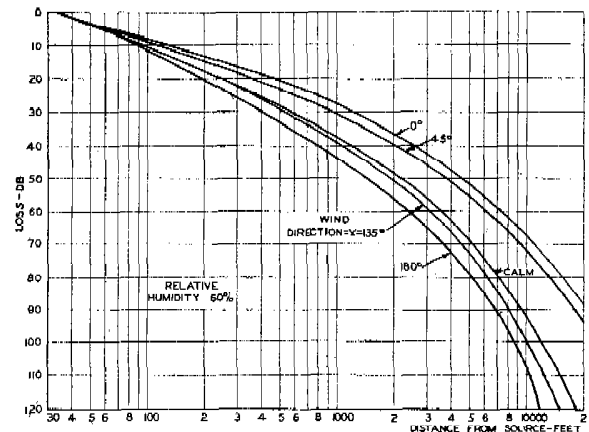

FIGURE 8. Transmission loss, range A, 1,000 c.

quencies it becomes very large, reaching 18 db per 1,000 ft at 5,000 c and 30 per cent humidity.

The final component of transmission loss is due to absorption by vegetation through which the sound must pass and by the surface over which it must travel. These losses must be determined empirically.

In addition to the general effects considered above, the sound intensity will be influenced by local conditions. Buildings and steep hills closely in front of the source will cause large reflection losses, and a listening post sheltered by such things will have lower than normal sound level. Obstructions in the middle portion of the sound path will have a less pronounced

effect. The loss in intensity will be more severe with positive curvature than with negative, for in the latter case the sound tends to ride over the obstruction and return to the ground beyond it. In general, obstructions are not a serious factor since the location of the sound source may usually be chosen to provide a clear sound field for a considerable distance and since an observation post will not normally be placed behind an obstruction.

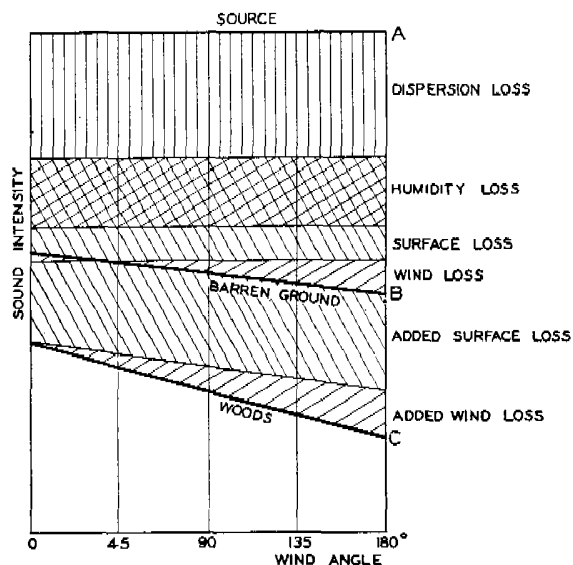

FIGURE 9. Component factors in transmission loss.

13.1.3

Experiments in Sound Transmission

The transmission of sound was studied over three types of terrain:

1. A flat sandy beach;
2. Flat and densely wooded; and
3. Also densely wooded but not so flat.

Two S2M amplifiers and loudspeakers (see Section 13.2.2) broadcast a warbled tone of 200-c band width generated by a Western Electric Co. 113-A oscillator. Measurements of sound intensity were made at various distances up to 3,500 ft by means of a Western Electric Co. 630-A microphone and an Electrical Research Products, Inc. [ERPI] RA277 sound frequency analyzer. Satisfactory data were obtained for frequencies from 600 to 5,000 c.

The sound intensity at distances of 1,000 ft or more fluctuated widely. The fluctuation in-

creased with distance and with the turbulence of the air and amounted to as much as 30 db at 1,000 ft on gusty days. The sound levels that were recorded were based on the frequently recurring peaks of intensity because of the importance of the maximum sound level in tactical problems.

Fifty-eight sets of sound transmission data were obtained under various combinations of

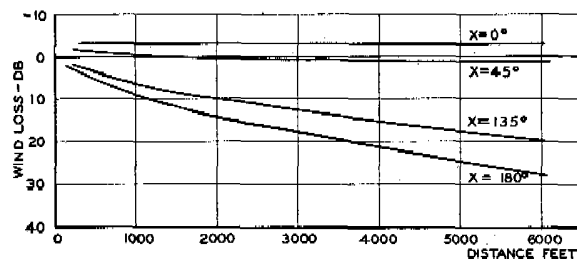

FIGURE 10. Wind loss on barren terrain.

wind direction and velocity. The temperature gradients were predominantly negative. A typical group of curves is shown in Figure 8.

The transmission loss for any particular set of conditions is the summation of component losses due to dispersion, air absorption, surface absorption, and wind. The components are shown diagrammatically in Figure 9.

The surface and wind losses are complex, and one of the main objectives of these experiments

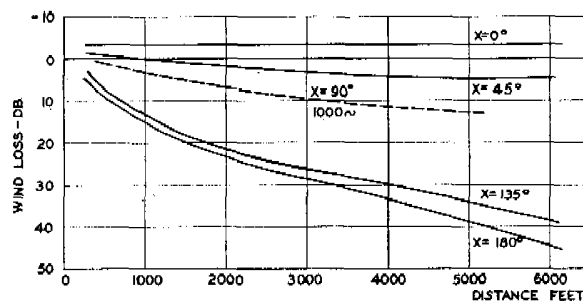

FIGURE 11. Wind loss on wooded terrain.

was to evaluate them empirically. A factor independent of frequency in the residual loss was attributed to wind effect. With a following wind the effect was a gain of 3 db per 1,000 ft. Figures 10 and 11 summarize the wind losses determined on barren and on wooded terrain respectively. The wind effect was found to be greater over wooded terrain than on the open

beach, perhaps because of a stratum of high wind gradient at the level of the tree tops. Transmission proved to be erratic in the presence of a cross wind and even more so during periods of dead calm.

The surface loss for barren sandy terrain was found by subtracting the dispersion, humidity, and wind losses from the total loss. A factor dependent on frequency varied from 0 to 4 db per 1,000 ft and was less at 1,000 c and greater for higher and also for lower frequencies.

When the dispersion, humidity, wind, and surface losses indicated by the curves are added the sum agrees with the average measured transmission to within ± 3 db. The transmission loss at any particular moment, however, may depart from the average value by a considerably greater amount so that the accuracy of prediction is more nearly ± 6 db. At other locations and over other terrains, the wind and surface losses will be different, and the error may be greater. More data, obtained under a wide variety of conditions, are necessary for satisfactory prediction of sound transmission over long distances, but it is believed that the present results are sufficiently accurate to permit the successful use of sound deception.^a

13.1.4 Masking Noise and Reception

Any frequency component of a complex sound can be heard if the level of that component is above the masking level for that particular frequency. As a result, conditions normally exist when a portion of a sound is clearly audible while other portions are masked. In predicting the reception of a sound it is, therefore, necessary to know the level and frequency spectrum of both the sound and the masking noise.

The sound level is a function of the sound source and of the transmission loss, while the masking noise is controlled by conditions at the listening point. This noise will obviously vary

^a Many additional data under a wider variety of conditions were obtained subsequently at the Army Experimental Station at Pine Camp. The results were incorporated in the ranging tables employed in actual combat operations.

widely from time to time, but it will have a reasonably stable minimum value. This minimum will exist when natural noises, such as that of rustling leaves and of the wind blowing past the ears, are the only sounds of importance. This level is of particular interest in sound deception because a listening post will normally be located in a quiet spot and also because the most effective results are obtained when the sound effects are audible only during lulls in the local noises.

The noise made by surf on a beach is also a stable natural noise. A very limited amount of data was obtained on its characteristics along the north New Jersey shore. It was found that the intensity levels 50 ft from the water edge were within the range of 70 to 90 db. On a gently sloping sandy beach, the intensity was quite steady, but on a steep or a rocky shore it was intermittent with variations of the order of 20 db. The frequency spectrum was found to be substantially flat below 500 c and to decrease 10 to 12 db per octave above that frequency. The level decreases rapidly as the listening point is moved inland and locations can usually be found within 100 yd where the surf noise is less than wind noise. Surf noise, therefore, should normally be disregarded for tactical purposes as any attempt to ride over it would make the sound too loud inshore.

MINIMUM MASKING NOISE

The masking noise level and spectrum were determined by three methods. In the first method, single-frequency sounds were generated by an S2M system and projected 4,000 ft. The sound level was first measured at full power as a reference, and the power of the source was then reduced until the sound was just audible. This latter sound level is equal to the masking noise and is found by subtracting the power reduction from the reference level. The frequency range covered was from 600 to 5,000 c. These data were then transformed to an equivalent intensity-per-cycle basis for continuous sounds and plotted.

The second method was the direct measurement of the noise with a 630-A microphone and an RA227 sound frequency analyzer. No wind screen was used on the microphone during the

test. Limitations of the equipment restricted the reading to low frequencies where the noise level is comparatively high. The average overall intensity levels are:

Wind Velocity	Intensity Level
1-6 mph	49 db
6-13 mph	56 db
13-18 mph	62 db

The third method consisted of listening tests by a number of observers to determine the minimum level at which the insertion of a high-pass filter could be detected. The manner in

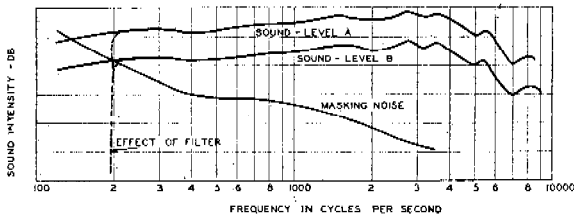

FIGURE 12. High-pass filter test of sound reception.

which this served to locate the masking level is illustrated in Figure 12. If the sound is at level A in the figure, the introduction of a 200-c high-pass filter will be heard because the sound level

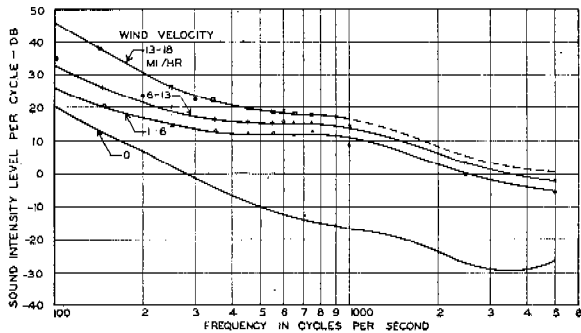

FIGURE 13. Wind noise masking of continuous spectrum sounds.

is higher than the noise level for an appreciable band below 200 c. If the sound level is decreased to B, the insertion of the filter will no longer be heard because all sound components below 200 c were already masked by the noise. The level below which the filter could not be detected is, therefore, a measure of the masking noise at the filter cutoff frequency.

These tests were made with an AES-4X system (see Section 10.2.3) as a source and with the listening position 100 ft from the horn. The range of tactical sounds was covered by using thermal, Model A Ford, and tank noises. The sound level was determined as in method 1 by measuring it at full power and then attenuating it the known amounts. The corresponding masking levels are plotted in Figure 13. This figure contains data from all three methods and smooth curves of masking noise levels as a function of frequency have been drawn for wind velocity ranges of 1 to 6, 6 to 13, and 13 to 18 mph. A fourth curve representing absolutely quiet conditions was derived from the threshold of audibility. It is of only theoretical interest since some noise is always present. These curves may be used to determine the masking effect of wind noises upon any sound that has a reasonably continuous frequency spectrum. For this purpose, the sound spectrum must be plotted on an energy-per-cycle basis.

These tests illustrate the difficulty of detecting the presence or absence of the very low frequency components of a sound. A corollary is that it is not necessary to reproduce those components. This is of value since raising the low-frequency cutoff of a system permits substantial reductions in its size and weight. It appears that the low-frequency cutoff may be made at about 80 c since it is unlikely that a deceptive sound will reach the observer at a high enough level for lower-frequency components to be heard, even if they are present. Similar tests with low-pass filters showed that frequency components above 5,000 c could not be heard at distances exceeding a few hundred feet. This restriction of the effective frequency range to between 80 and 5,000 c is confirmed by the analyses of typical problems. These facts provided the justification for simplifying the AES-4X system before it was produced in quantity as the AES-4 (see Section 13.2.3).

SOUND INTENSITY SUITABLE FOR DECEPTION

The sound must have a level well above the masking noise for high quality reception. However, as stated before, it appears best for deceptive purposes to maintain the level close to the masking noise so that the observer can hear it

~~CONFIDENTIAL~~

only during quiet periods in the local noise. During these quiet periods, it is necessary that the listener hear a sufficiently wide frequency band to give the sound character. It is found that for the great majority of sounds, this band is most effective when centered below 500 c. If the band is too narrow or at too high a frequency, all sounds tend to sound like escaping steam. Experience to date indicates that *optimum conditions are obtained with a band width of at least two octaves having an intensity level about 15 db above the masking level.*

The sound technician must produce this level by controlling either the signal voltage at the loudspeaker, or the distance over which the sound is transmitted. Under field conditions, there is neither time nor personnel available to compute these values. Operating tables valid for practically all operating conditions have therefore been prepared listing the voltage and the maximum range for four types of systems (S2M, AES-1, AES-2, and AES-4). This reduces field procedure to the simple operation of looking up a value in a book.¹

13.2 SONIC DECEPTION: HEATERS

13.2.1 Experimental Equipment Developed for the Armed Forces

The acoustic equipment for sound deception consists, fundamentally, of a means of storing and reproducing sound effects, of amplifiers and loudspeakers, and of a power supply. The magnetic type of recorder-reproducer was selected because it is capable of good fidelity and volume range, is compact and portable, and withstands shock and movement during use; and, furthermore, the records do not require any processing. The essential feature of the amplifier and loudspeaker is that they have an adequate power capacity and fidelity to cover the tactical requirements. Either a battery or a gasoline engine generator may be used for supplying power.

Two distinct classes of equipment were developed. The first, known as the Heater¹ and later designated S2M and more recently Heater Mark 1 by the Navy, is a 500-watt system con-

sisting of an assembly of component parts that had been designed largely for other purposes. The other lot, known as the Junior Heaters¹ and assigned Army Experimental Station [AES] numbers, have 250-watt power capacity and were developed specifically for this purpose. One S2M and ten AES systems were built under OSRD contract (Projects 17.3-4.2 and 17.3-4.3).

13.2.2 Heater (S2M)

The Heater consists of a magnetic recorder-reproducer, an amplifier, two loudspeakers, a

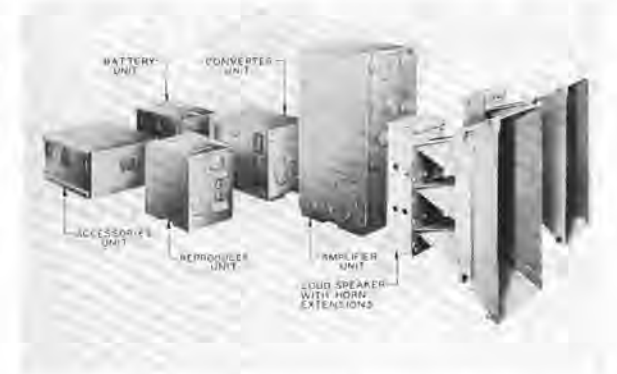

FIGURE 14. Component parts of Heater.

battery, a rotary converter, and necessary spare parts and accessories. All units except the loudspeakers are housed in portable weatherproof wooden boxes. Flexible cables with waterproof plugs and jacks are used to interconnect the various units. An assembled system is shown in Figure 14, and its schematic circuit diagram in Figure 15. The dimensions and weights of the units are listed in Table 1.

TABLE 1. Dimensions and weights of Heater (Western Electric Code No. X-66021).

Unit	Length (in.)	Height (in.)	Width (in.)	Weight (lb)
Battery	32	18	17	280
Converter	32	22	21	300
Reproducer	25	21	16	90
Amplifier	24	47	24	415
Loudspeaker A	29	17	22	240
Loudspeaker B	29	17	22	240
Accessories box	36	14	24	175
Total				1,740

The magnetic recorder-reproducer is a standard design manufactured by the Armour Research Foundation. The recording medium is 0.004-in. music wire, about two miles of wire being required for a 30-minute recording. Longitudinal magnetization with high-frequency bias and erasure is used. The wire is driven from one spool to another by an induction motor through friction clutches and belts, and must be rewound before a record is reproduced.

A preliminary and a power amplifier are housed in one box. They are Western Electric products designated D-150300 and D-150229

plastic throat assemblies. Rectangular horns having a conical flare are used, the mouth of each horn being 7.25 in. by 9.5 in. These horns are assembled together in a 3 by 2 pattern so that the mouth of the assembly is 14.5 in. by 28.5 in. A plywood horn extension is provided to increase the size of this opening to 20 in. by 40 in., and normally the two loudspeakers of the system are mounted side by side to form a square.

The battery was designed originally for use in torpedoes. It is of the lead storage type with 24 cells capable of delivering 35 amperes for

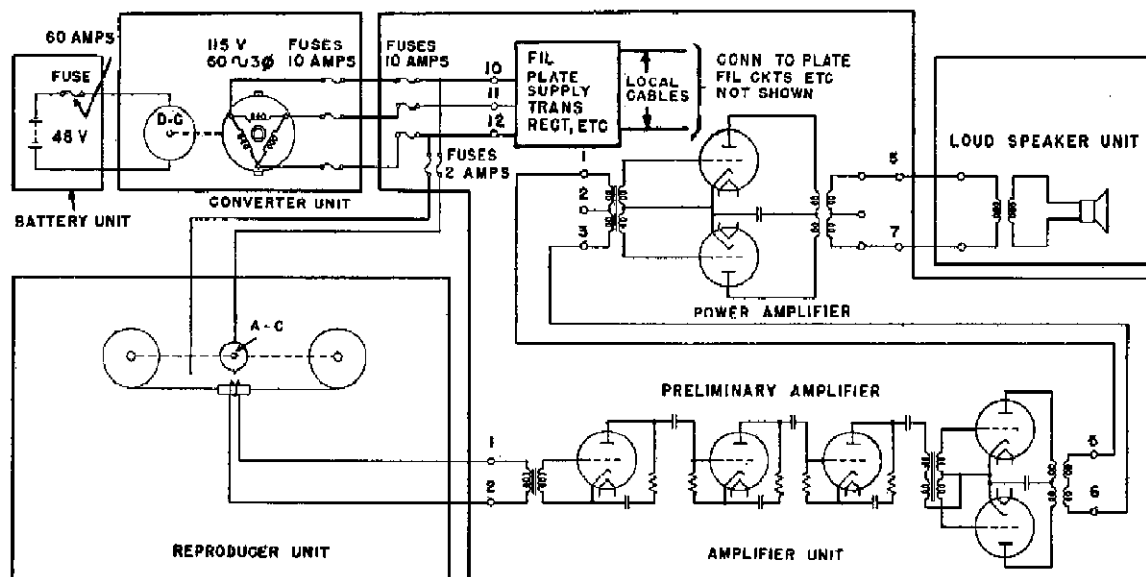

FIGURE 15. Simplified schematic circuit of Heater.

and are used in general announcing systems aboard ships of the U. S. Navy. The power amplifier consists of a single class B stage and is capable of delivering 500 watts to a 20-ohm load. Forced ventilation is provided.

The loudspeakers were also designed for the Navy's general announcing systems. Each speaker, designated Western Electric Co. D-173234, consists of an assembly of six receiver units and six horns. The receivers are of the moving coil type and have permanent magnet fields. The diaphragms are of phenolic impregnated fabric, and the coils are wound with enameled copper wire. Their resonant frequency is about 550 c. The diaphragms are acoustically coupled to the horns by molded

30 minutes at a nominal 48 volts. It is designed for short life but may be used for a number of duty cycles if recharged promptly. A thermostatically controlled heater is provided.

A rotary inverted converter is also provided. It is driven by the battery and has an a-c capacity of 2 kva at 115 volts, 60 c, 3-phase, with a 90 per cent power factor. The 3-phase power is required by the amplifier which was designed for use on warships having this supply. Its speed is 1,200 rpm. This unit will supply sufficient power to operate the reproducer and the amplifiers.

The converter may be started and stopped by a manual switch on the control panel, and the magnetic reproducer may be controlled by

a switch on its panel. In addition, a time switch is provided to start the converter automatically at any selected time within 24 hours. Circuits are also provided so that the apparatus may be started and stopped by remote control and so that the amplifier and loudspeakers may be used as the audio end of a radio receiver. In addition, an auxiliary switch is closed when the magnetic recorder has reached the end of its program. This switch could be used to actuate

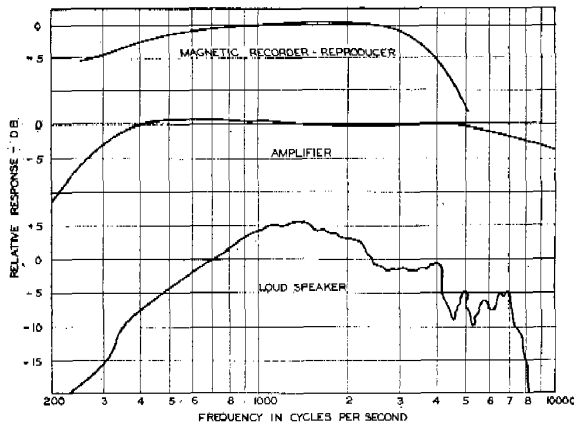

FIGURE 16. Frequency response of Heater.

a detonator. Accessories consist of a microphone, operating cables, hydrometer syringe, tools, and spare parts such as vacuum tubes, fuzes, and plugs.

PERFORMANCE

The frequency-response curves of the magnetic reproducer, the amplifiers, and the loudspeakers are shown in Figure 16. The restricted low-frequency response of the loudspeakers together with their high efficiency in the 1,500-c region provide excellent transmission of speech in noisy areas. The low-frequency cutoff is primarily due to the stiffness of the diaphragm assembly. Such characteristics, in general, limit the use of this equipment in deceptive work to suggestive caricature of typical sounds rather than faithful reproduction. This speaker was used because it was more powerful than any other.

As the loudspeaker will not reproduce the lower-frequency components of a sound, it would obviously be inefficient to waste amplifier capacity on them. The frequency response of the

amplifier is, therefore, cut off sharply below 400 c. This is done in the preamplifier so that the full 500-watt capacity of the power amplifier is available for the higher frequencies.

The overall capabilities of the system are shown in Figure 17 where the sound intensity on the horn axis 30 ft from the mouth is plotted as a function of frequency. The data were obtained with the two loudspeakers located side by side (the manner in which they were ultimately used). Single-frequency tones were used. The volume controls were adjusted so that at 1,000 c the amplifier delivered 500 watts to the loudspeakers. The intensities shown in Figure 17 are the maximum available. A signal-to-noise ratio of 30 to 35 db, imposed by the magnetic reproducer, was the best that was available in this system.

In general, the S2M systems have proven valuable in the field and are still the most powerful ones available.

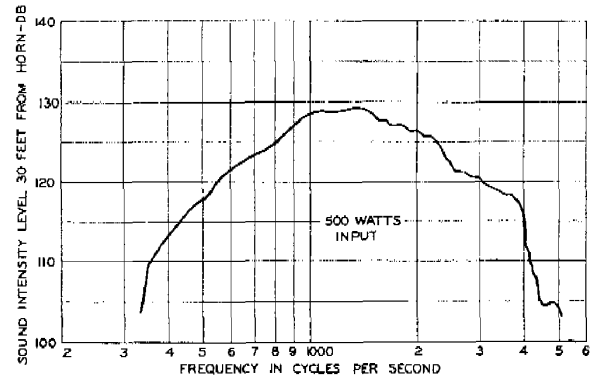

FIGURE 17. Sound intensity level of Heater.

13.2.3

Junior Heater (AES)

Experience with the Heater and initial work at the Army Experimental Station indicated the need for a system that covered a wider frequency range, that was more readily portable, and that included a more rugged magnetic reproducer. In order to limit the weight and bulk, the power capacity was limited to 250 watts, half that of the Heater. Nearly all of the component units had to be designed specifically for this purpose. A typical system consists of an alternator driven by a gasoline engine, a magnetic recorder-reproducer, an amplifier,

~~CONFIDENTIAL~~

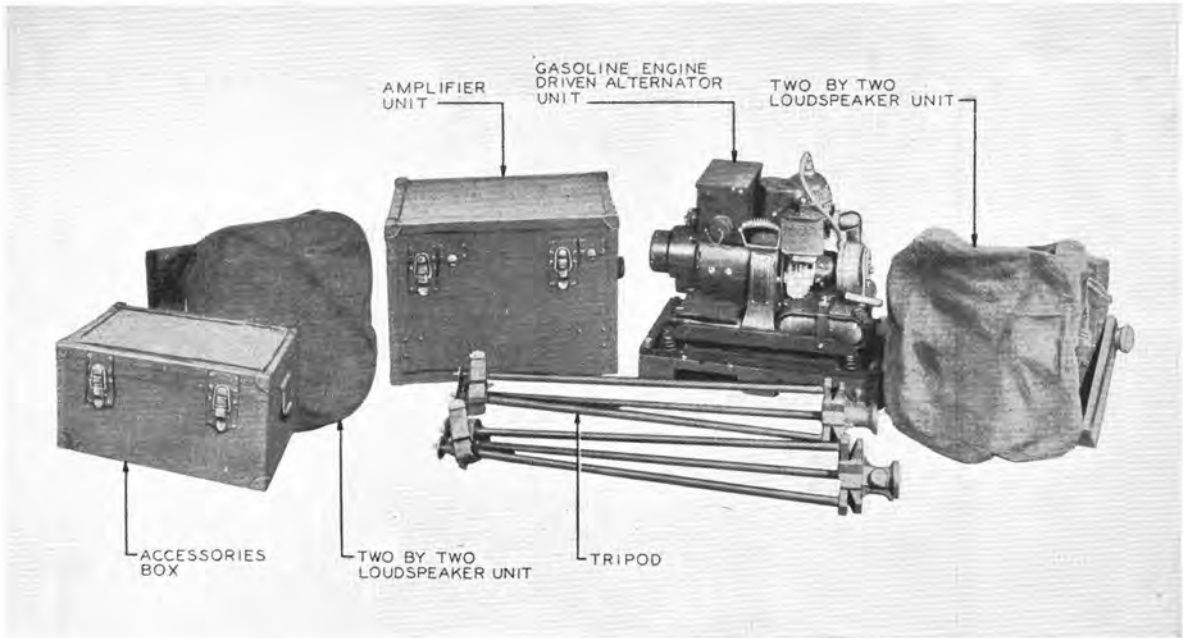

FIGURE 18. Component parts of Junior Heater (AES-1).

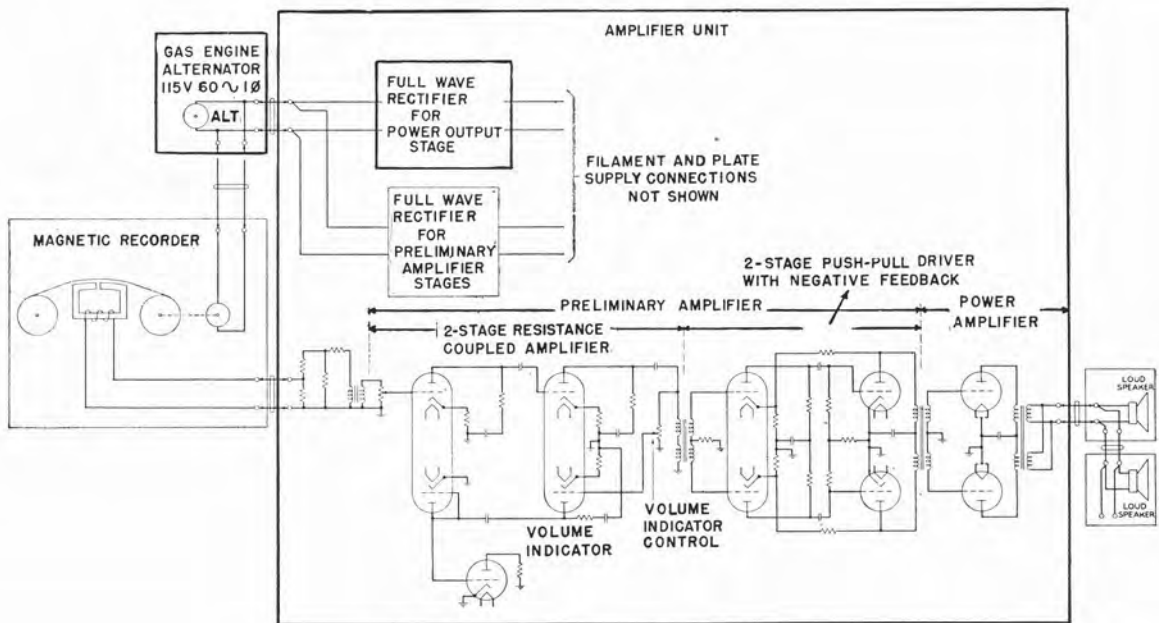

FIGURE 19. Simplified schematic circuit of Junior Heater.

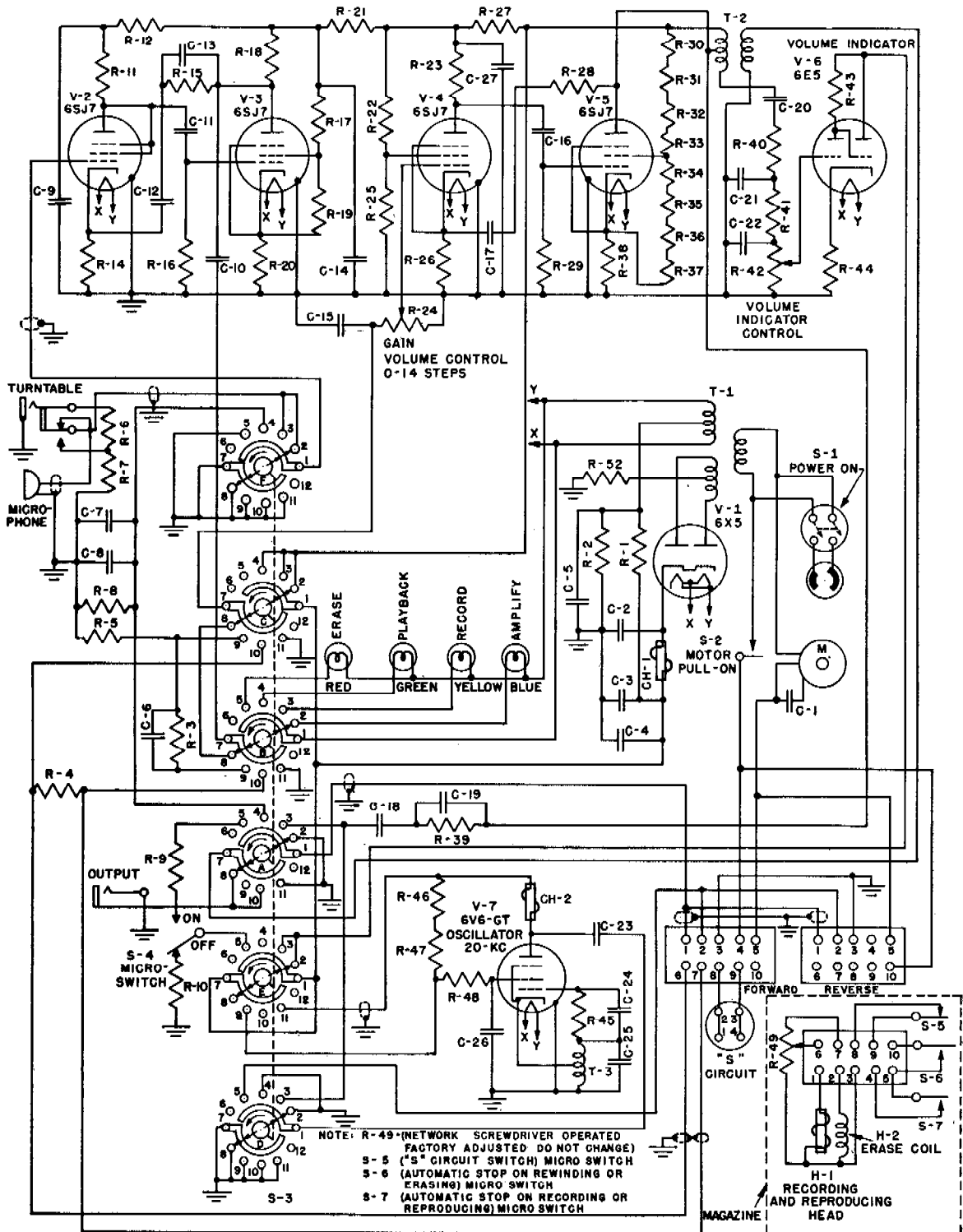

FIGURE 20. Circuit of recorder-reproducer (Junior Heater).

two loudspeakers, an accessories box, a magazine box containing spare magazines for the magnetic recorder, tripods for mounting the loudspeakers, and mounting details for installing the system in a jeep. A depot spares box is supplied with each group of systems. Input connections are provided so that either a magnetic microphone (D-173334) or a carbon lip microphone (D-173335) may be used in place of the magnetic reproducer to convert the equipment to a public address system. The loudspeakers can be a pair of any one of three types designated AES-1, AES-3, and AES-4, and the systems are commonly referred to by the loudspeaker type. Thus a Junior Heater equipped with AES-1 speakers is known as an AES-1 system. The units of a system are connected to each other by flexible cables with a weather-proof plug on each end. An AES-1 system is shown assembled for transportation in Figure 18, and a simplified circuit diagram is shown in Figure 19. The size and weight of each of the component parts are given in Table 2.

MAGNETIC RECORDER-REPRODUCER

The improved magnetic recorder-reproducer used with this equipment was developed jointly by the Bell Telephone Laboratories and the Brush Development Company under a Navy contract. It is designated the KS-12009 mag-

TABLE 2. Dimensions and weights of Junior Heater.

Unit	Length (in.)	Height (in.)	Width (in.)	Weight (lb)
Engine alternator	25	18	18	125
Reproducer	25	22	15	140
Amplifier	22	17	15	150
*Loudspeaker AES-1	24	19	17	56
AES-3	43	25	25	45
AES-4	35	48	24	125
†Tripod	38	6	6	21
Accessories box	22	11	15	60
Magazine box	16	13	9	50
Cable bag	10	20	20	25
Depot spares box	36	15	26	160

* Two loudspeakers of one type required.

† Tripods not used with AES-4.

netic recorder and is manufactured by the Brush Company. Its schematic circuit diagram is shown in Figure 20. The recorder consists of two parts, an amplifier case permanently

assembled in the box and a removable magazine. The amplifier case contains an amplifier, an oscillator, a motor, manual switching and control circuits, and input and output receptacles. The magazine contains all moving parts except the motor; these include the magnetic wire, the recording-reproducing head, an erase coil, timing indicators, and automatic control switches. The magazine is easily removable from the amplifier case, connections being made through plugs and jacks in the electric circuits and a spline coupling on the motor shaft. When the magazine is mounted in one position, the motor couples directly to one of the wire spools, and the wire can be pulled in the forward direction. If the magazine is rotated 180 degrees, the motor will couple to the other spool, and the wire can be rewound. Figure 21 is a view of the magazine with cover removed. A magazine will provide a half-hour reproduction, and a continuous program of indefinite length may be obtained by using two amplifier cases and a number of magazines or by using only one amplifier case if interruptions of a few seconds while changing magazines can be tolerated.

The recording is made by longitudinal magnetization of 0.006-in. stainless-steel wire moving at about 5 ft per sec. Linearity is obtained by the use of a 20-kc bias current superimposed on the recording signal current. The same electromagnetic structure is used for reproducing and for recording.

The timing mechanism is in the magazine and is controlled by the movement of the wire. It indicates minutes and seconds of recording time from the start of the wire. Limit switches associated with it stop the motor just before the end of the wire in both the forward and the reverse directions.

The recording efficiency of the wire and head is greatest at about 1,500 c and decreases substantially at both higher and lower frequencies. Equalizers are provided to compensate for this, and the resulting overall frequency characteristic is approximately flat from 200 to 5,000 c. The volume range is about 40 db.

MICROPHONES

A magnetic or a carbon microphone may also be used for the input signal for the amplifier.

In the field of deception, this is of little value, but the existence of this feature makes possible the rapid conversion of the equipment into a high-power public address system.

AMPLIFIER

The amplifier unit includes the preliminary amplifier, power amplifier, filament and plate supply for both amplifiers, ventilating fan, and input networks. The equipment inside its box is protected from rain, dirt, and dust. The volume control knob is located under an auxiliary

application of high voltage to the plates of the rectifier tubes until the filaments are heated. The operation of the thermostatically operated relay closes the winding of the electromagnetic relay causing it to pull up and lock. The operation of the electromagnetic relay closes the filament circuit of the power amplifier tubes and the plate circuit of the rectifier tubes, and opens the heater resistance circuit of the thermostatically operated tube.

The amplifier has a maximum gain of 94 db and an output capacity of 250 watts into 4.5

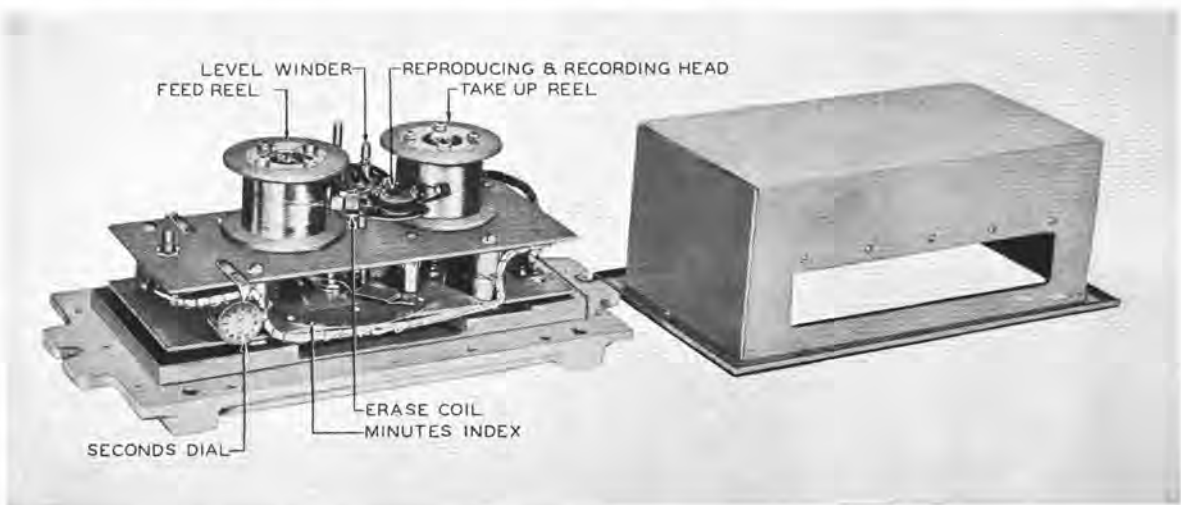

FIGURE 21. Magazine of recorder-producer (Junior Heater).

weatherproof metal cover next to the inlet ventilating hood. By turning back the metal cover, the weatherproof volume control knob is exposed, and the electric eye may be viewed through a Lucite panel. The amplifier circuit is shown schematically in Figure 22.

The preliminary amplifier consists of two resistance-coupled stages plus two resistance-coupled push-pull stages with transformer coupling between them.

The power amplifier consists of a single push-pull stage transformer coupled to the preliminary amplifier and to the output, and includes a self-contained power pack. The power pack also provides the filament, plate, and screen currents to the preliminary amplifier. To avoid any danger of damaging the rectifier tubes of the power amplifier, a thermostatically operated time delay relay is provided which delays the

ohms. The frequency characteristic is flat from 50 to 10,000 c.

LOUDSPEAKERS

The series of loudspeakers differ from one another primarily in their size and construction and in their low-frequency cutoff, the AES-1 having the highest cutoff and the AES-4 the lowest. The AES-1 and the AES-3 use the same receiver unit, the difference in their characteristics being controlled by their horns. The receiver is of the moving coil type with a permanent magnet field. The coil is of enameled copper wire and the diaphragm of phenolic impregnated fabric. It has an impedance of 9 ohms and a power capacity of about 30 watts.

The AES-1 loudspeaker consists of four receiver units mounted in the corners of a square and coupled to four 250-c exponential horns. It

is shown in Figure 23. The units are connected in series-parallel so that the loudspeaker impedance is 9 ohms. The frequency response has rather sharp cutoffs at 350 and 6,000 c and a broad 10 db peak at about 2,000 c. The sound intensity on the axis 30 ft from the horn mouth,



FIGURE 23. Loudspeaker AES-1.

for an input of 125 watts single frequency, is shown in Figure 24. As the effective mouth dimensions are only about 15 in. by 15 in., the sound is spread over a large angle. At 500 c, the sound level 30 degrees off the axis is only 1 db less than maximum.

The AES-3 loudspeaker (Figure 25) also has four receiver units, but they are all coupled to the throat of a single 113-c horn. The combina-

tion, coupler and horn, is 42 in. long. The frequency response is slowly rising from 130 to 500 c, is flat from 500 to 3,000 c, dips at 4,000 c, and then recovers to 5,500 c. The sound intensity for 125 watts input is plotted in Figure 26. The horn has a mouth diameter of 24 in. This makes the 500-c sound level 2 db below maximum at 30 degrees off the axis.

Another loudspeaker was designed for experimental use at Fort Hancock. It is known as the AES-4X, and consists of two Western Electric Co. KS-12004 cone-type receivers, two Western Electric Co. 713A high-frequency receivers, and an electric frequency-dividing network. The cone-type units radiate through a 60-c exponential horn, and the high-frequency units are coupled to a 250-c horn with a 6-in. mouth. The housing and low-frequency horn

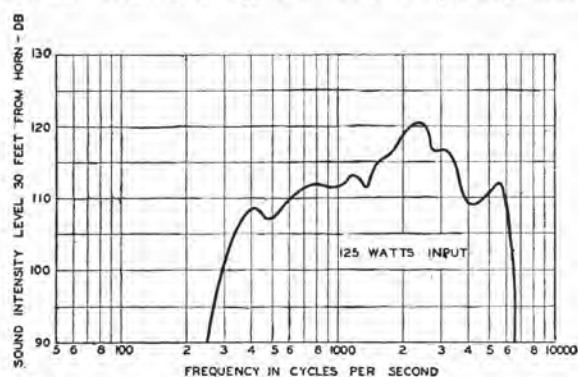

FIGURE 24. Sound intensity level of one AES-1 loudspeaker.

are of wood. The assembly has an effective frequency range of 50 to 15,000 c, as shown by the dotted curve in Figure 27.

Using this speaker and a number of high- and low-pass filters, the maximum effective frequency range was determined for various operating conditions. These tests showed that neither the very high nor the extreme low frequencies were required. The high-frequency receivers and electric networks were, therefore, eliminated and the horn shortened by changing its taper from 60 to 90 c. In this form the assembly is known as the AES-4 loudspeaker. It is shown in Figure 28.

The receivers in AES-4 have permanent magnet fields and moisture-resistant paper cones and have an impedance of 20 ohms each. The four receivers, however, will not reliably with-

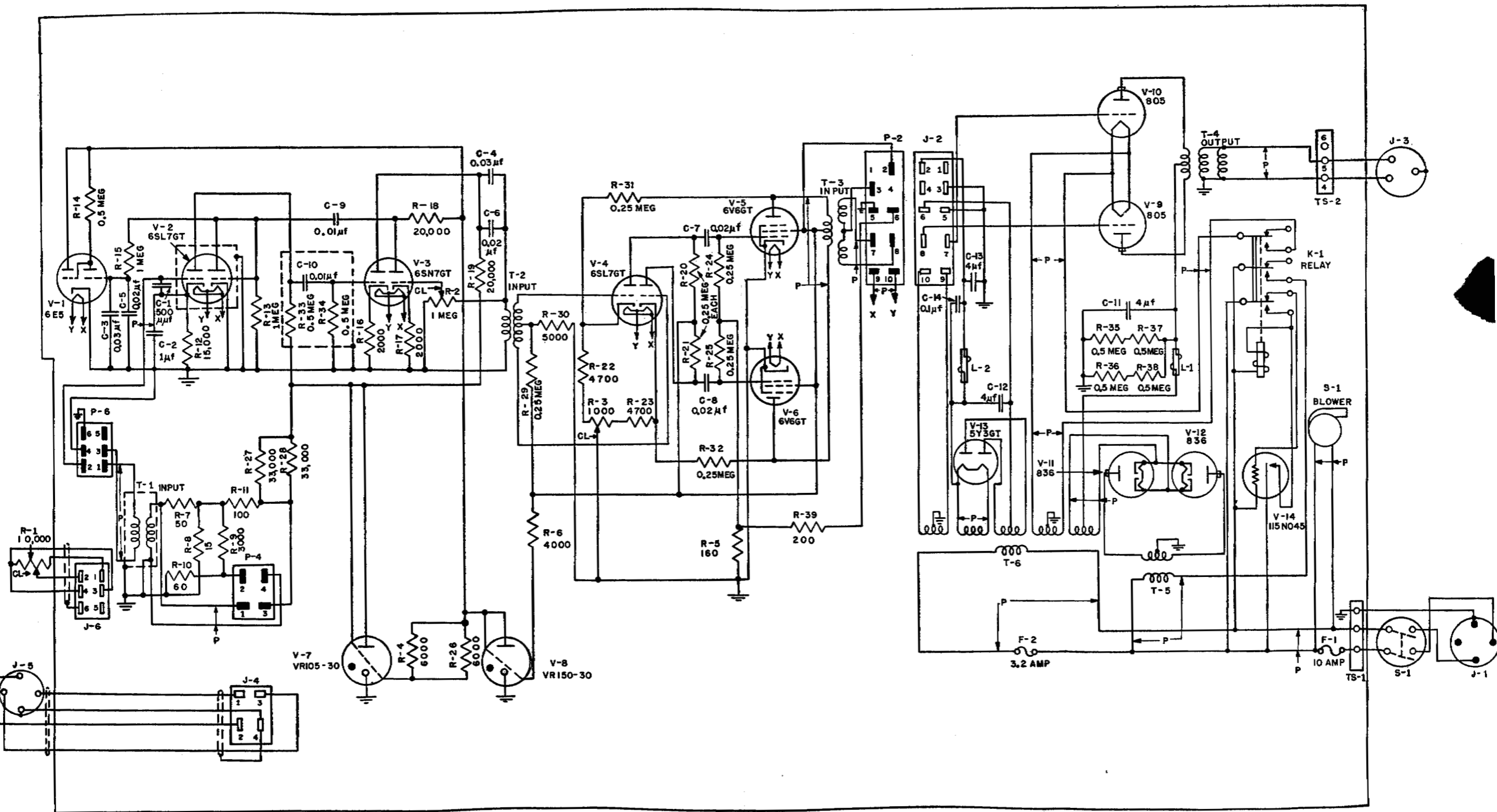

FIGURE 22. Circuit of amplifier (Junior Heater).

stand 250 watts, and in operation the amplifier output is limited to 150 watts. The sound intensity developed with this input is shown in Figure 27. The frequency response is gradually rising from 70 to 3,500 c and then falls at a

supplied by a Homelite alternator driven by a gasoline engine. It is rated at 115 volts, 60 c, single phase, 1,500 watts at 90 per cent power factor. It is equipped with automatic speed and voltage regulators but must be started manually.



FIGURE 25. Loudspeaker AES-3.

somewhat steeper rate from 3,500 to 10,000 c. The two units, mounted together, form a mouth 48 in. square and, as a result, are quite directional, the 500-c sound intensity 30 degrees off the axis being down 16 db.

POWER SUPPLY

Sufficient power to operate two systems is

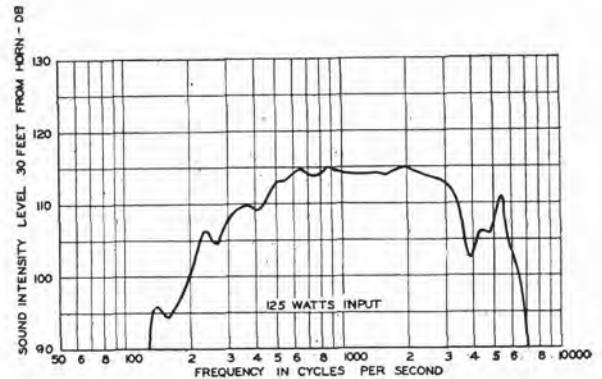

FIGURE 26. Sound intensity level of one AES-3 loudspeaker.

13.3 A REMOTE CONTROL DEVICE FOR HEATERS

The RC (remote control)² is a radio device designed as an accessory to the Heater. Since one of the functions of the Heater is to attract enemy attention and possibly draw fire, the desirability of controlling such equipment from a remote position is obvious.

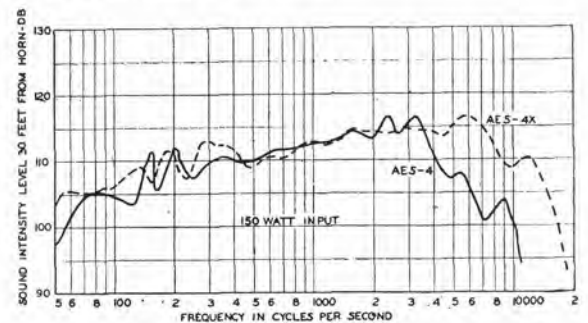

FIGURE 27. Sound intensity level of two AES-4X and two AES-4 loudspeakers.

13.3.1 Operational and Design Requirements

To operate the Heater it is necessary to:

1. Turn on the power to the receiver and the audio system;
2. Start the wire recorder;

3. Stop the recorder and turn off the power;
4. Destroy the Heater by detonation.

In designing the RC, an effort was made to provide a simple, light, rugged device constructed of standard parts and to make it adapt-

because of the greater simplicity and economy of the alternative method described below.

OPERATION OF STEPPING SWITCH BY SIGNAL PULSES

In this method a single carrier frequency and a single modulation frequency are utilized. The modulation signal is pulsed the desired number of times by means of a telephone dial. The carrier wave of the MN transmitter, as modulated by the control signal, is broadcast and received remotely by the MN receiver. The MN receiver output is fed directly to the RC receiver section. Here it is filtered and its pulses utilized to control a sensitive relay which in turn operates a conventional telephone stepping switch.

Three models of the RC were built on this general plan. The first was based on a modulation frequency of 500 c. This frequency proved unsatisfactory, however, because of the tendency of the equipment to be operated by speech signals from other stations. The situation was improved somewhat by using a modulation frequency of 1,000 c, but the instrument tended to be sluggish and not entirely reliable in its operation. The sluggishness was found to be inherent in the electronic circuits employed and in the pulsing relay and stepping switch.

The first model will not be here described in detail since the second and third models based on a modulation frequency of 16,000 c proved far superior.

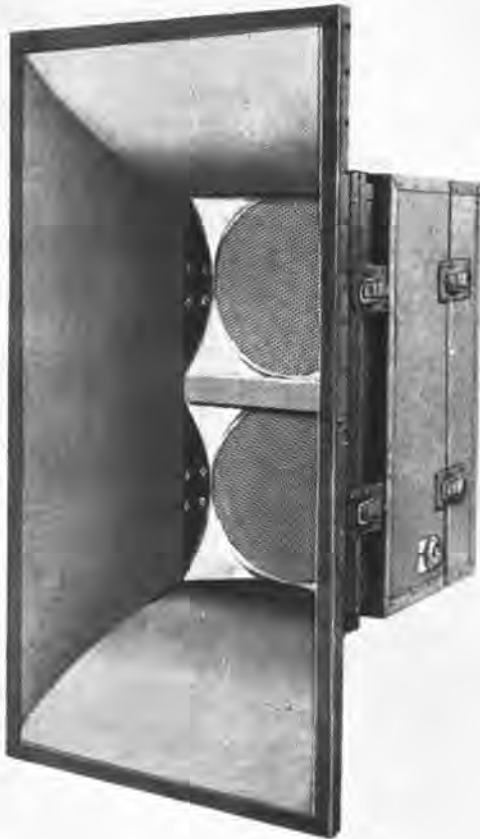

FIGURE 28. Loudspeaker AES-4.

able for use with standard Army or Navy transmitters and receivers.

CONTROL BY SELECTIVE TUNING

The possibility was considered of selecting a carrier frequency and four modulation frequencies, one for each circuit to be controlled. It would be possible to separate the signals by means of selective filters and thus operate four separate relays to perform the four required functions. This method was rejected, however,

13.3.2

RC Model No. 2

A modulation frequency of 16,000 c was selected because:

1. The signal is not likely to be detected by listening;
2. The signal carries a very small percentage of voice energy;
3. The lagging, found so troublesome at 1,000 c, is greatly reduced; and
4. Very efficient filters for this frequency can be provided easily.

A Navy (type MN) frequency-modulated transmitter and receiver was employed. It is assumed that the telephone stepping switch and also delay circuits appropriate for use with tele-

phone dials and stepping switches are familiar both in principle and in operation. Both devices are employed in the RC Model No. 2.

An inductive-capacitive filter was placed before a voltage limiter in the receiving section to attenuate subharmonic frequencies of the modulation frequency and to add selectivity to the system.

The basic filter system on which the selectivity of the system depends consists of a parallel T null circuit in a degenerative path around a high-gain amplifier. The parallel T null circuit consists of two T networks, each of which is an attenuator and a phase shifter.

It was found advantageous to introduce a peak limiter in advance of the T-filter in order to keep the maximum noise level at the pulsing relay below that which would operate the relay. In Model No. 2 a cathode follower was inserted after each amplifier in the T-filter as an impedance-matching device. This matching was required because of the high amplification required by the high selectivity of the filter system.

13.3.3

RC Model No. 3

Further simplification was achieved in Model 3 by substituting an inductive-capacitive filter of high selectivity for the T-network filter. Under favorable signal conditions, that is, when the signal-to-noise ratio is sufficiently high and static interference not so great as to prevent transmission of satisfactory voice signals, Model 3 operates with a high degree of reliability. Under marginal or bad receiving conditions, however, Model 3 is inferior to Model 2.

Neither Model 3 nor Model 2 utilizes the audio band of frequencies, and therefore the control circuits do not diminish the usefulness of the transmitter and receiver for the usual audio purposes.

No special precautions were taken to prevent detection of signals by the enemy. Since not more than four numbers are likely to be dialed and usually one is sufficient, it is apparent that detection must be done in a matter of 1.5 seconds or less. Although this is not impossible, it hardly seems probable.

The possibility of operation on false signals can be greatly reduced by reducing the sensitivity with the volume control. In case the device does not operate reliably at reduced sensitivity, the probability of correct operation may be increased by repeated dialing of the number desired. Experience in the Hoboken area, at Fort Hancock, and at Pine Camp indicated that the danger of spurious operation from false broadcast signals is practically nil.

Both Models 2 and 3 are 11½ in. long, 5½ in. wide, 6 in. deep, and weigh 10 lb each. The devices will stand as much abuse as their component parts, all of which are standard tubes, accessories, relays, and stepping switches.

A complete field manual describing the circuits employed, their adjustment and operation for both Models 2 and 3 has been prepared.²

13.4

THE WATER HEATER

13.4.1

Introduction

The Water Heater is a special naval mine that contains a high-powered acoustic system and timing devices for the projection of sound for deceptive purposes or for "psychological warfare." The acoustic and timing systems³ were developed by the Bell Telephone Laboratories, and the vehicle and power supply⁴ were provided by the General Electric Company. The details of the division were established by agreement between the engineers of the two companies.

GENERAL DESCRIPTION OF THE WATER HEATER

The Water Heater is 21 in. in diameter by 21 ft long and has the same physical contour as the Mark 18 torpedo. It is fired from a standard submerged torpedo tube and runs for a predetermined distance along a preset course. Upon completion of its run, it drops anchor and rises to the surface, floating with its axis vertical and with the shell projecting about 2 ft out of the water.

At a predetermined time, a loudspeaker is elevated 6 ft above the water and is pointed in a preset magnetic compass direction. A recorded sound program is then reproduced. The pro-

gram may consist of speech or of tactical sounds such as engines, winches, and anchor chains. A total of 30 minutes of sound is available, and this may be broken into several intervals dis-

tributed over 2 hours. The Water Heater may be set to arm or destroy itself at the completion of the program.

13.4.2 Acoustic and Timing System

The acoustic system of the Water Heater utilizes a magnetic wire reproducer as a signal source. Electric impulses from this source are amplified and are then converted into sound by a loudspeaker. The various components of the acoustic and timing system are shown in Figure 29, and their dimensions and weights are given in Table 3.

TABLE 3. Dimensions and weights of components of acoustic and timing system.

Description	Height (in.)	Width (in.)	Length (in.)	Weight (lb)
Equipment rack	14	10	49	120
Magazine	6	5	14	12
Loudspeaker	16	14	16	105
Attenuator	3	6	7	7
Waiting time clock	3.5	5.25 diam		4
Total				248

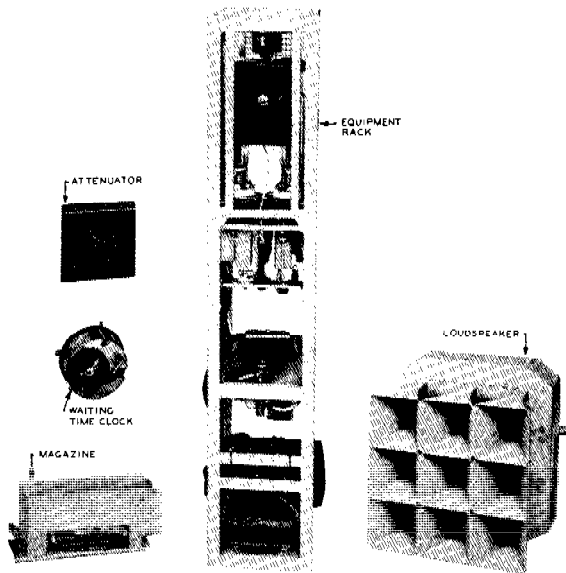

FIGURE 29. Acoustic and timing system.

The capabilities of the device are:

- Range 5,000 yd max
- Speed 10 knots
- Running depth 20-50 ft
- Angle fire 90 degrees right or left
- Anchor cable 300, 600, or 900 ft
- Elapsed time between final adjustment and start of sound program 12 hours max
- Total duration of program 2 hours max
- Total duration of sound, divisible into one to ten separate periods 30 minutes max
- Sound range, adverse weather favorable 1,000 yd
- Spread of effective sound beam 60 degrees (30 degrees from axis)

Three models of the Water Heater were completed in all. The first model of the Water Heater was built and tested before the second and third models were constructed. This permitted the incorporation of desirable changes in the later models. In the acoustic and timing system these changes consisted of reducing the weight by the use of aluminum, of lengthening

the equipment rack 3 in. to shift the dynamotors aft by that amount, of mounting the power relay on the rack, and of using a reproducer head that is less sensitive to stray fields. The following description of the apparatus is based on the improved design.

The assembled mine is shown in Figure 30 as it appears before it is launched. Arrows indicate the location of the loudspeaker compartment near the nose, the equipment rack and magazine compartment just forward of the center, and the attenuator and waiting time clock in the afterbody. The rectangular handhole providing access to the magazine is also indicated.

When the mine has been launched and has traveled the designated distance, it anchors itself and upends so that its axis becomes vertical. In this condition it floats with 30 in. of the forward end projecting out of the water as shown in Figure 31. A few minutes before the sound program starts the loudspeaker is elevated about 6 ft above the water and is pointed in a preset direction as shown in Figure 32. Before elevation, the loudspeaker is packed in the shell with the horns pointing along the axis

of the mine, but, as soon as it is elevated clear of the shell, a latch is tripped, and the loudspeaker swings on trunnions under the influ-

nal voltage is generated in a pickup coil in the magnetic wire reproducer. From there it is transmitted directly to a 10,000-ohm volume



FIGURE 30. Water Heater prepared for firing.

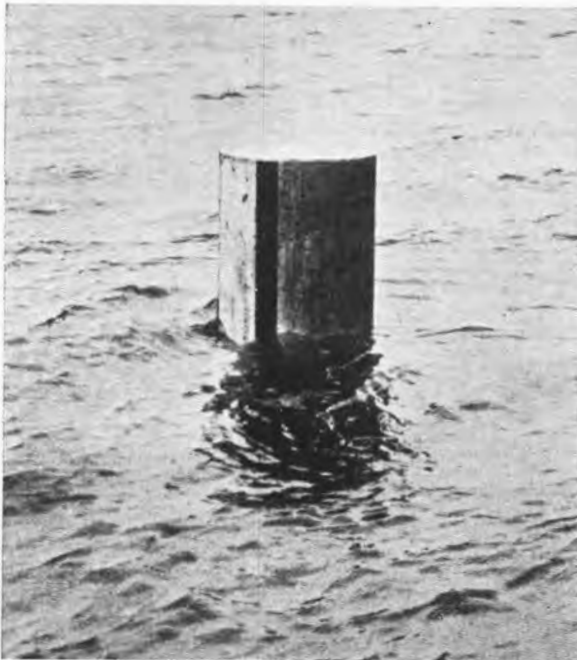

FIGURE 31. Water Heater at anchor.

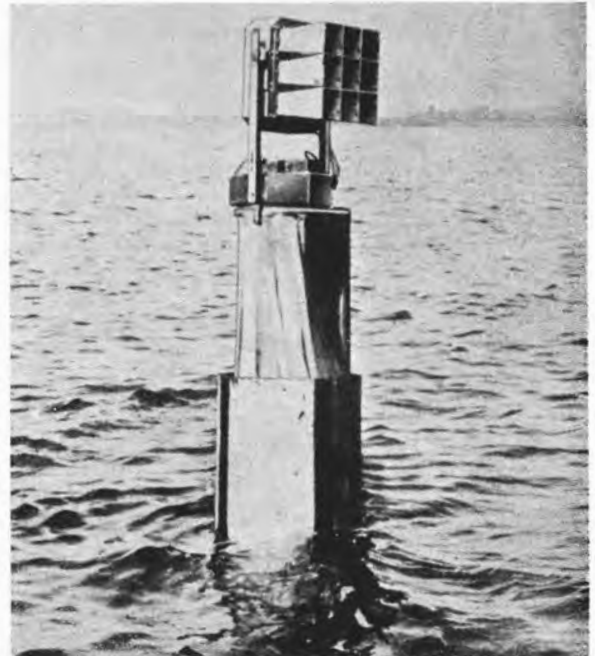

FIGURE 32. Water Heater in operating position.

ence of gravity so that the horn axis becomes horizontal.

ELECTRIC CIRCUITS

A simplified schematic diagram of the transmission circuit is shown in Figure 33. The sig-

nal voltage is generated in a pickup coil in the magnetic wire reproducer. The amplifier terminates in an output transformer and is capable of supplying 500 watts to a 4.5-ohm load. After leaving the amplifier, the signal goes through a test jack and an attenuator, and finally reaches

the loudspeaker where it is converted into sound. The attenuator is used to adjust the sound intensity level.

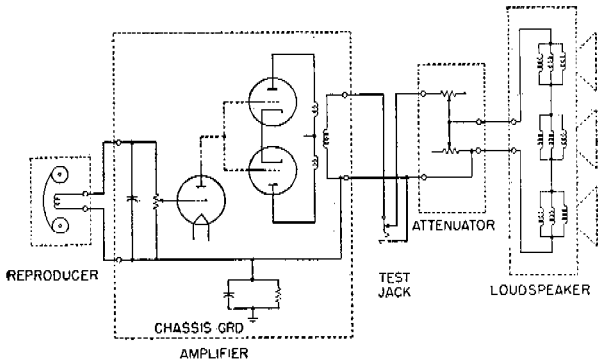

FIGURE 33. Transmission circuit.

A schematic diagram of power, control, and transmission circuits is shown in Figure 34. It may be seen that the entire circuit is inactive until switch S-12 is closed and the hands of the

mechanically, starts the program clock, and energizes switch S-9. Some minutes later, when a moving finger on the program clock closes switch S-9, the power relay will operate. This closes the power circuits from the battery to the reproducer drive, the amplifier, the two dynamotors, and the fan. The power relay locks itself up electrically through switch S-8 (normally closed) and the 50-ohm resistor on the reproducer.

The sound reproduction will then start and will continue until switch S-8 is opened by coming in contact with one of the cams on the reproducer time control bar. Opening this switch releases the power relay and shuts down the reproducing system. (The program clock finger has moved on by this time so that switch S-9 is again open.) This sequence of operation of switches S-8 and S-9 is repeated for each part of the sound program. The system may also be started by closing toggle switch S-10

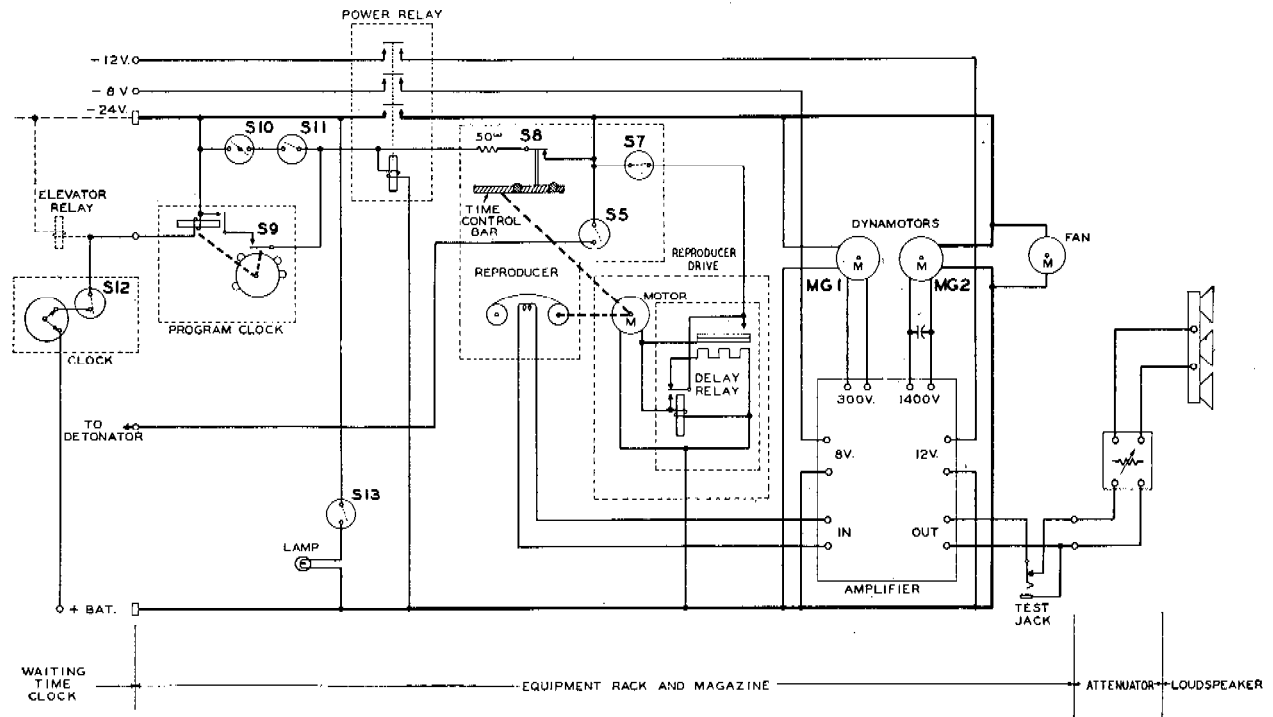

FIGURE 34. Control and power circuits.

waiting time clock bridge the clock contacts. Completing this circuit causes the relay in the program clock and also the loudspeaker elevator relay to operate. The clock relay locks itself up

and pushbutton switch S-11. This is a convenience when testing and adjusting the amplifier.

Switch S-5 may be used to arm or destroy the mine at the completion of the sound pro-

gram. Switch S-7 is a limit switch designed to stop the reproducer at the end of the magnetic wire.

A thermostatic delay relay is provided in the motor circuit of the reproducer. Its function is to permit the amplifier to warm up for 20 seconds before the reproducer is started.

MAGAZINE

The magnetic wire reproducer and a program clock are built into a magazine that may be

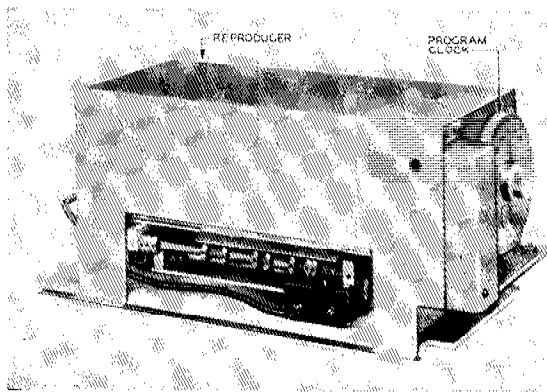

FIGURE 35. Magazine.

easily removed from the mine, a special rectangular handhole being provided for this purpose. This feature permits taking these components to an operating base laboratory where facilities are available for recording the sound program on the magnetic wire and for setting the program time controls.

A view of the assembled magazine is shown in Figure 35. The switch fingers around the dial of the program clock and the cams on the reproducer time control bar are readily accessible. Electric connections are made through a multicircuit jack in the magazine base. Spline shafts also project through the base. One of them engages a coupling on the reproducer drive motor.

Although the reproducer and the clock are thus mounted together, they are, in fact, distinct pieces of apparatus and must be considered separately.

REPRODUCER

The reproducer is shown in Figures 36 and 37. In these views both the outer cover and a

Permalloy shield have been removed to expose the reproducing mechanism. The essential parts are about 2 miles of 0.006-in. magnetic alloy steel wire (sufficient for a 30-minute recording), two spools, a recording and reproducing head assembly including erase coil and wire guides, a layer winding mechanism of the fishing reel type, brake bands to maintain tension on the wire, and a time control mechanism.

Before being reproduced, the program material must be recorded on the wire exactly as described for the Heater in Section 13.2.3, where the principles of the wire recorder are explained. Between recording and reproduction and between reproductions it is necessary to rewind the wire. To do this, the reproducer must be shifted on the recorder so that the motor is connected to the other reel.

The time control mechanism is shown in Figure 37. As the spools rotate, a horizontal feed screw geared to them causes microswitch S-8 to travel along the length of the reproducer from right to left. This switch remains closed and thus locks up the power relay until its operating pin comes in contact with one of the cams along the time bar. When pressure against this cam opens the switch, the power relay will be released and the system shut down. Thus, if a cam is set along the bar so that it just makes contact with the switch pin at the completion of a section of the recording, the system will stop automatically at that point in the program. Ten cams are provided, so the program may be divided into as many as ten sections.

PROGRAM CLOCK

The program clock is shown in Figures 38 and 39. It consists essentially of a clock mechanism, a microswitch, a relay, and a group of aluminum disks mounted on the clock shaft in place of a hand. The outer of these disks is a dial that is graduated in minutes from 0 to 120. It also has a "start" line located 15 minutes before zero. The other disks are ten time cams and a back plate. Each time cam has a triangular projection at one point on its periphery. The dial and back plate are keyed to the clock shaft, but the time cams are held only by friction. The pressure required to clamp them is applied by a knurled nut on the shaft. When

this nut is loosened, the cams may be rotated so that their projections are opposite desired points on the dial. A microswitch and operating lever are mounted adjacent to the time cams.

vents it from making more than one revolution, and the clock is reset and wound by rotating the dial clockwise. A relay is mounted adjacent to the clock mechanism. When it operates, it

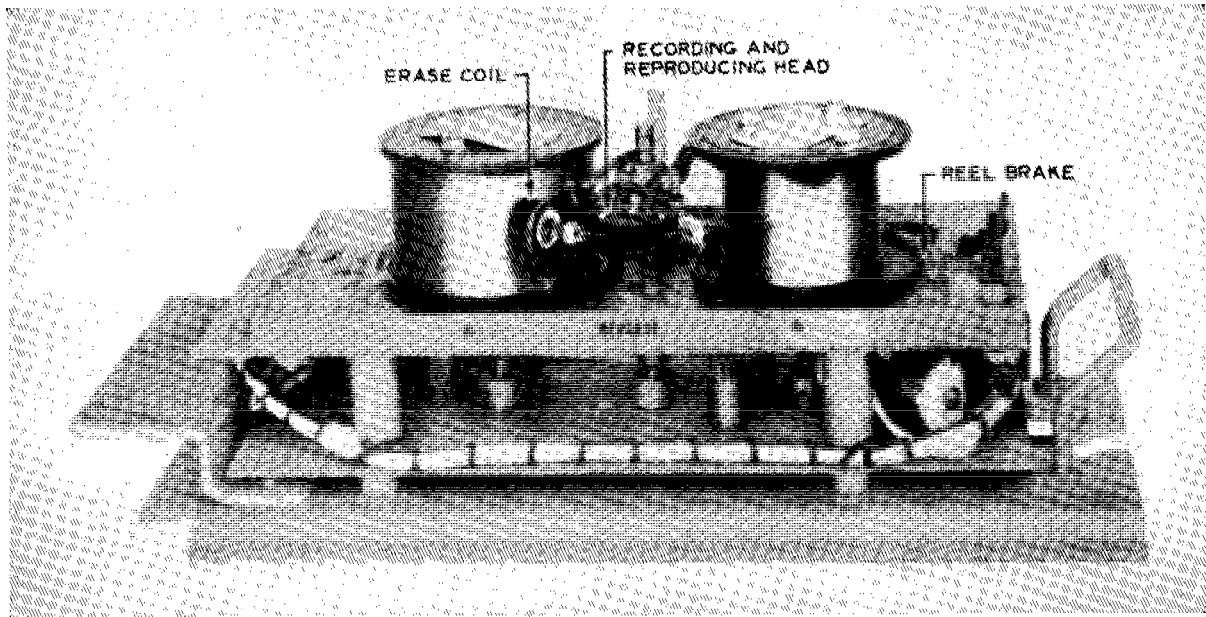

FIGURE 36. Reproducer, cover and shield removed, reverse position.

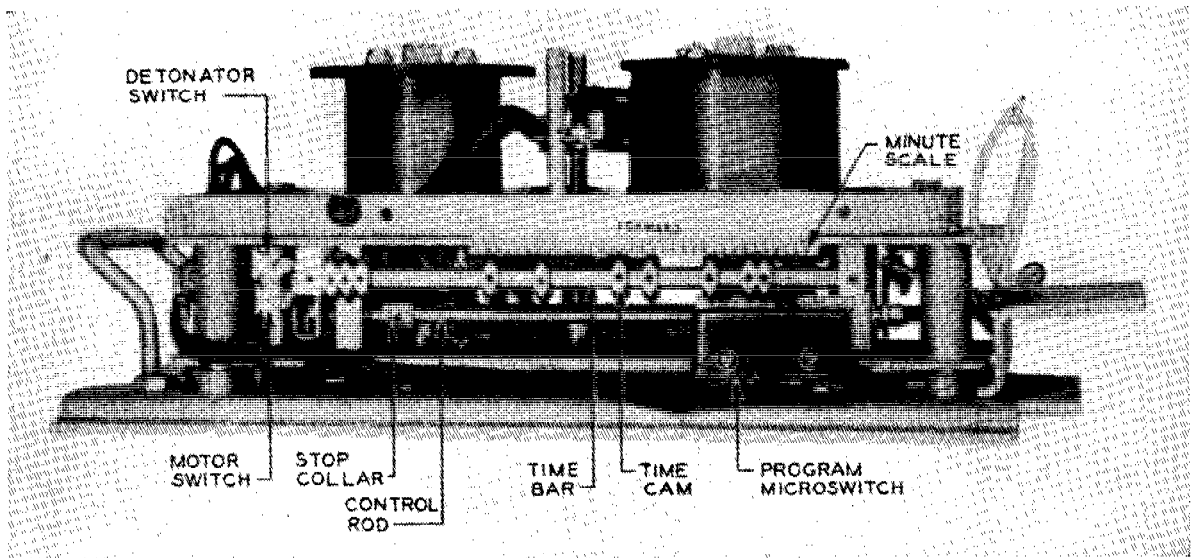

FIGURE 37. Reproducer, cover and shield removed, forward position.

As the cams rotate, their projections move the operating lever and close the microswitch.

The dial rotates in a counterclockwise direction when the clock is running. A stop pin pre-

closes electric contacts in series with the microswitch, and at the same time it removes a mechanical brake from the clock balance wheel, thus starting the clock. The relay locks itself

in the operated position by means of a latch. This latch may be released by moving the stop lever to the right as viewed from the front of the panel.

The clock is prepared for use by adjusting the time cams, setting the relay at normal, and setting the dial so that the "start" line coincides with the V of the operating lever. The position of the time cams is determined by the time

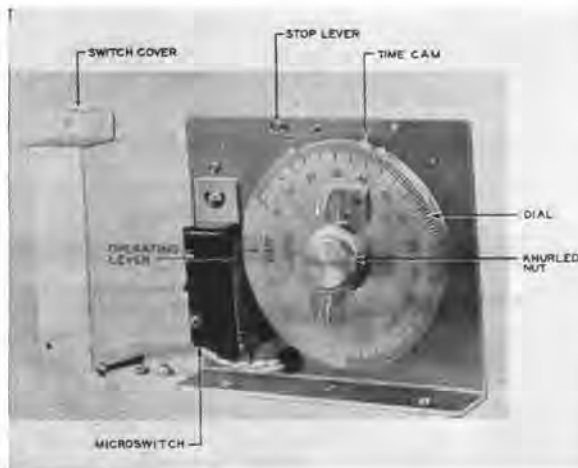

FIGURE 38. Program clock, front view.

schedule of the sound program. A cam set at the dial mark indicates the time each section of the program is to start. When mounted in the Heater, the closure of the waiting time clock contacts energizes the relay. This starts the program clock and closes the circuit to the microswitch. Fifteen minutes later the zero mark on the dial is opposite the V of the operating lever. The first time cam is normally set at this point. Pressure of this or of any other cam on the lever closes the microswitch and starts the sound system.

EQUIPMENT RACK ASSEMBLY

The equipment rack assembly consists of the reproducer drive, the amplifier, the low- and high-voltage dynamotors, and auxiliary equipment all mounted on an aluminum rack. This rack also holds the magazine when it is in place in the mine. Two views of the assembly are shown in Figures 40 and 41.

REPRODUCER DRIVE

Top and bottom views of the reproducer drive unit are shown in Figures 42 and 43. The prime mover is a 24-volt, $\frac{1}{25}$ -hp, 5,600-rpm, d-c motor. The speed is held constant by a centrifugal contact governor that cuts a resistance in or out of the motor circuit. The motor is coupled to a 10/1 worm-gear speed reducer to obtain the required 560 rpm at the reproducer shaft.

AMPLIFIER

The amplifier and amplifier circuit are shown in Figures 44 and 45. The voltage from the reproducer is fed to volume control P-1 shunted by a 0.01- μ f capacitor. This capacitor resonates with the coil in the reproducer head and improves the high-frequency response of the system. After leaving the volume control, the signal is amplified by a 6SH7 pentode and then a 6J5 triode. The output of the triode is transformer-coupled to a 6SL7 used as a push-pull triode. The next stage consists of four 6V6 tubes connected in parallel push-pull. The final stage consists of four 805 tubes in parallel push-pull, transformer-coupled to the preceding stage and to the output. The filament current

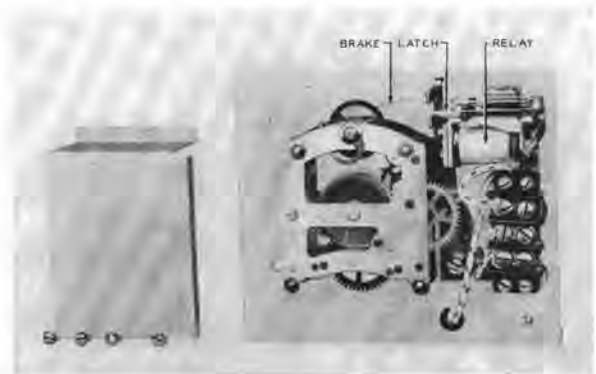

FIGURE 39. Program clock, rear view.

for this power stage is obtained from a 12-volt tap on the battery and the 1,400-volt plate supply from the high-voltage dynamotor. Filament current for all other tubes is obtained from an 8-volt battery tap, and their plate supply is from the 300-volt low-voltage dynamotor. The plate voltage for the first stages is stabilized and decoupled from the dynamotor by voltage-regulator tubes V-8 and V-9. The regu-

lation of the amplifier is improved by negative feedback around the third and fourth stages (R-15 and R-16).

The gain of the amplifier is about 120 db, and its output power capacity is 500 watts into

0.64 ampere. The unit is 6 in. in diameter by 11 in. long, and weighs 39 lb.

MINOR EQUIPMENT

Air is circulated over the amplifier by an 8-in. fan driven by a 24-volt d-c series motor.

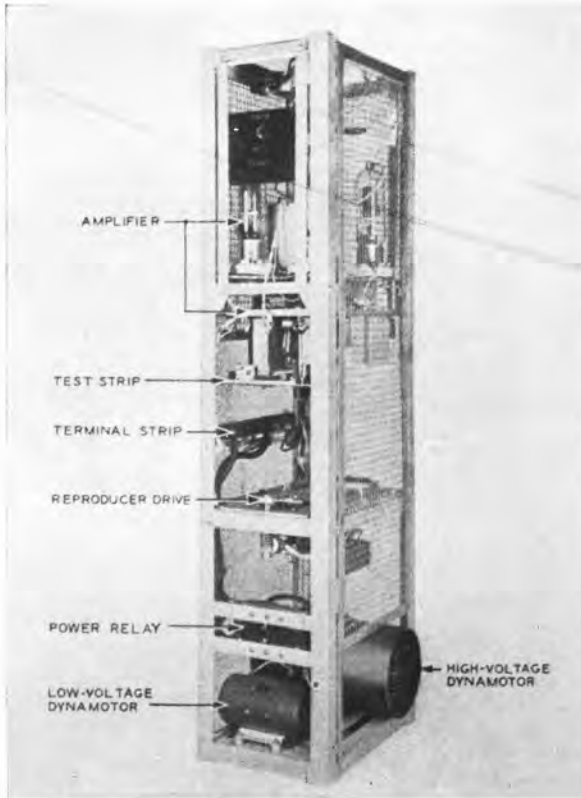

FIGURE 40. Equipment rack.

4.5 ohms. Its frequency-response characteristic is flat from 300 to 5,000 c.

LOW-VOLTAGE DYNAMOTOR

The low-voltage dynamotor is one of a standard design covered by Bell Telephone Laboratories specification KS-5558, L2. It is normally used on a 28-volt supply and will deliver 0.180 ampere at 285 to 320 volts.

HIGH-VOLTAGE DYNAMOTOR

The high-voltage dynamotor was designed especially for this project. With an input of 21.5 volts, 60 amperes, it will deliver 1,250 volts,

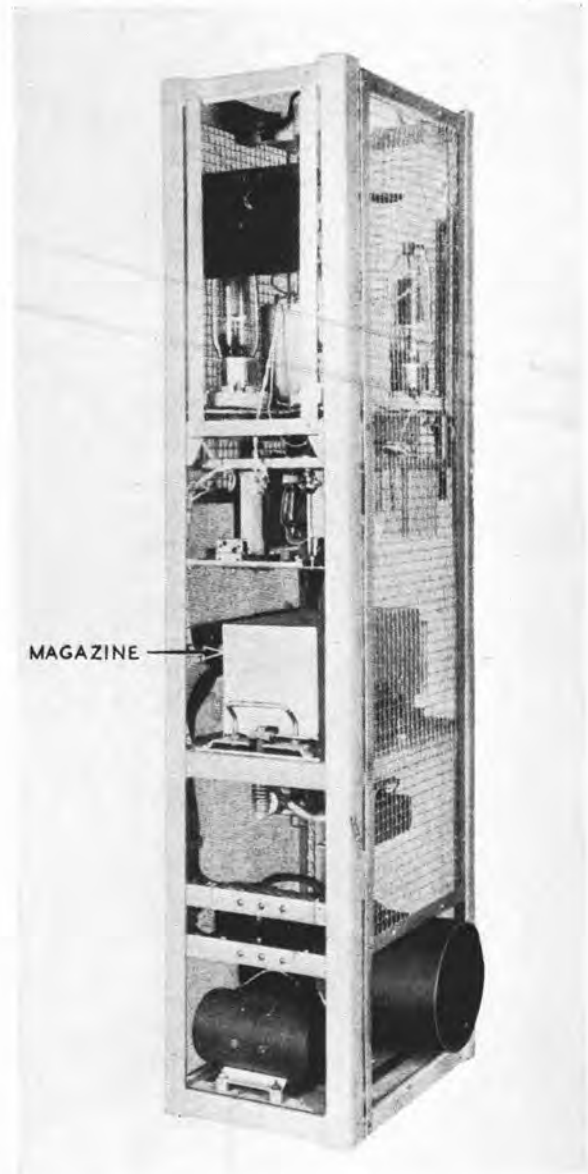

FIGURE 41. Equipment rack with magazine.

The power relay is a 3-pole, single-throw switch connected in the circuits between the battery and the apparatus on the equipment rack.

A test strip is located on the side of the rack just below the amplifier. In this position it is accessible through the magazine handhole. It contains the knob of the amplifier volume control, the toggle and pushbutton switches for

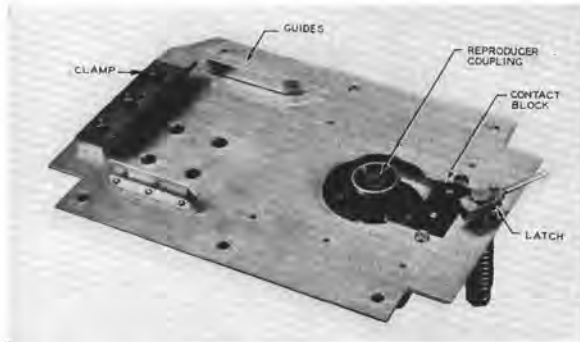

FIGURE 42. Reproducer drive, top view.

manually starting the acoustical system, the test jack by which a resistor load may be substituted for the loudspeaker, and a toggle switch and 24-volt lamp for illumination.

The 3,000-volt, 0.5- μ f capacitor, C-10, is connected across the output of the high-voltage

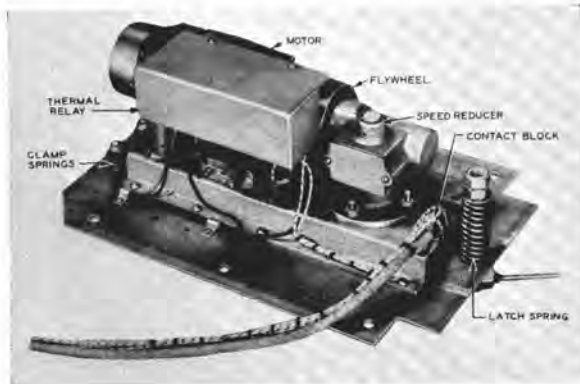

FIGURE 43. Reproducer drive, bottom view.

dynamotor to reduce the commutator ripple in its output voltage.

LOUDSPEAKER

The loudspeaker is exceptionally light and compact, measuring 16 by 14 by 16 in. and weighing 105 lb. It has a power capacity of 500 watts, giving a ratio of only 3.3 oz per watt capacity. It consists essentially of eighteen re-

ceiver units coupled to nine horns. It is shown in Figure 46.

The horns are made of aluminum. They are 10 in. long with a 250-c exponential taper and have 4.5-in. square mouths. The main housing is made of steel. In addition to supporting and protecting the receiver unit, this housing provides magnetic shielding that reduces the stray field set up by the receiver magnets. This is important as the magnetic compass used to orient the loudspeaker is located nearby. The

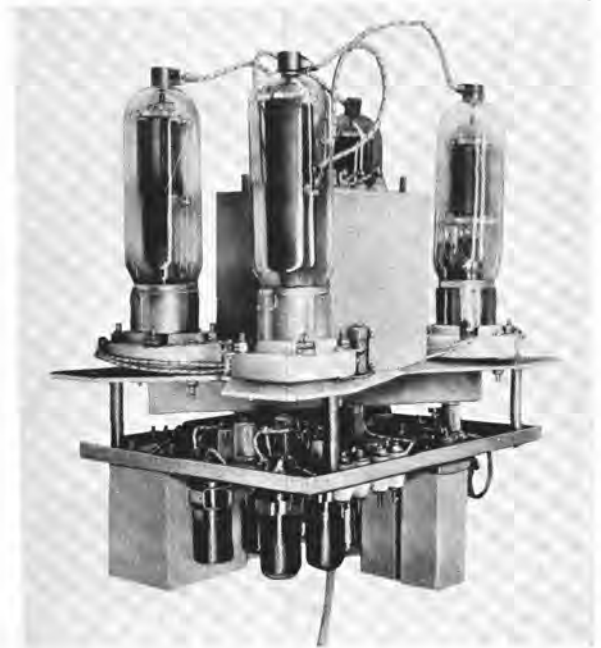

FIGURE 44. Amplifier.

unit is mounted on trunnions projecting from the sides of the housing. They are located directly above the center of gravity so that when swinging freely the horn axes remain horizontal.

The receiver units assembled in the housing are shown in Figure 47. They are grouped in subassemblies of two receivers each. The receivers are of the moving coil type with permanent magnet fields and phenolic impregnated fabric diaphragms. A plastic coupler provides efficient acoustic coupling between the diaphragm and the throat of the horn. In the subassembly, the two diaphragms face each other and work

into a common chamber. They are phased so that their effect is additive.

Each receiver has an impedance of 9 ohms,

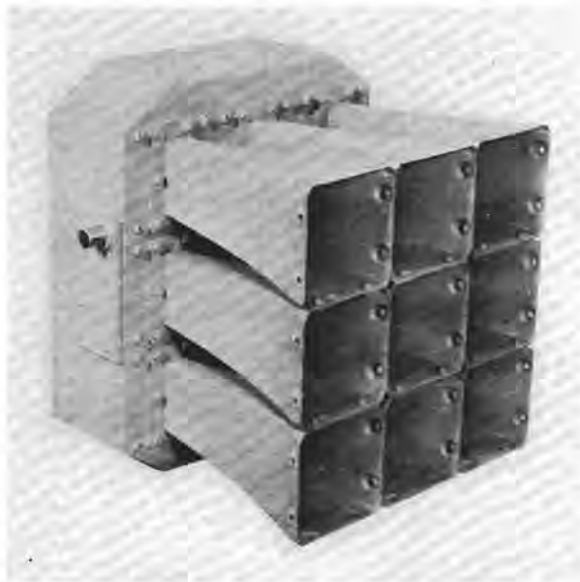

FIGURE 46. Loudspeaker.

and the subassembly, consisting of two receivers in parallel, has an impedance of 4.5 ohms.



FIGURE 47. Loudspeaker, cover removed.

The subassemblies are connected in groups of three in parallel, and these groups are connected in series. This makes the assembled

loudspeaker also have an impedance of 4.5 ohms. The d-c resistance is about 65 per cent of the impedance. This method of wiring provides a very dependable loudspeaker as the failure of any one receiver simply shifts its load to the other five in parallel with it. This results in only a negligible decrease in the sound output, and the receivers have sufficient marginal power capacity to carry the excess load for the short time required.

The relative frequency-response characteristic of the loudspeaker is shown in Figure 48. The dip at 3,800 c is caused by interference between the two opposing diaphragms of the subassemblies, the effective distance between

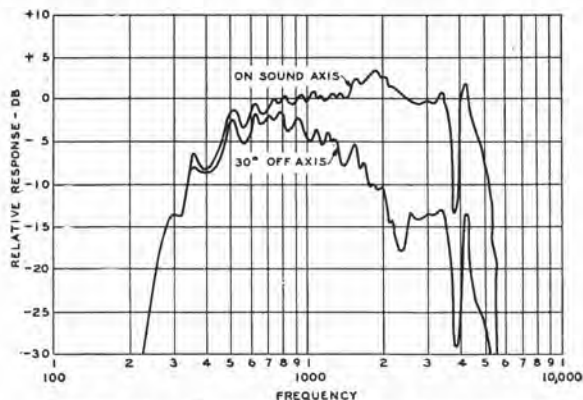

FIGURE 48. Frequency-response characteristic.

them being one-half wavelength at that frequency. A better low-frequency response would be desirable, but this could only be provided by increasing the size of the horns, and space limitations do not permit it. An electric input of 500 watts in the 1,000-c region will produce a sound intensity level of 118 db on the sound axis 30 ft from the horn mouth.

The response at 30 degrees off the sound axis is also shown in Figure 48. Below 1,000 c, little loss in level is produced by moving off the axis, but at higher frequencies the loss becomes increasingly greater. These high frequencies are of only minor importance in sound deception so that the 30-degree response is tolerable.¹ However, any further lowering of the effective high-frequency cutoff would be serious.

ATTENUATOR

The attenuator is connected between the amplifier output and the loudspeaker. In this cir-

cuit location it attenuates the background noise by the same amount that it attenuates the signal and thus provides the maximum signal-to-noise ratio at all sound levels. Also the fact that it is a separate unit allows it to be mounted in the afterbody where it is most readily accessible. The arrangement has the disadvantage that the attenuator must have a power capacity of 500 watts. Commercially available attenuators do not even approach this rating so a unit had to be designed especially for this project. It is shown in rear view with cover removed in



FIGURE 49. Attenuator, cover removed.

Figure 49. Two tapped resistor units are used, one in series with the line and one in shunt. They are made by wrapping resistor wire in a helical groove cut in the outer surface of ceramic tubes. The taps are connected to the points of a 9-pole, 2-deck selector switch. The resistors are proportioned so that, when the switch is rotated, the input resistor remains constant at 4.5 ohms but the attenuation varies between zero and 40 db in 5-db steps.

The case is made of anodized copper to provide maximum heat radiation and is perforated to permit air circulation. It is 6 in. square by 2.5 in. high. Input and output receptacles and the switch knob extend beyond these dimensions.

WAITING TIME CLOCK

The waiting time clock is an accurate time switch that may be set to close an electric circuit within 1 minute of any desired time within 12 hours. It is 5.25 in. in diameter by 3.5 in. high and weighs 4 lb. It is mounted in the afterbody on the inside surface of a handhole cover. This is the same handhole that provides access to the attenuator.

The clock is shown in Figure 50. The hour and minute hands and the dial are of a conventional design. The hands may be set to the correct time by rotating the minute hand the required number of revolutions in the counterclockwise direction.

The clock is normally prevented from running by a spring-wire brake on the rim of the balance wheel. This brake is removed and the clock starts when the toggle switch shown in the figure is thrown to "on." Operating this switch also closes an electric circuit from the connector block to a "minute" contact.

The dial is surrounded by a ring that contains an index and a flexible minute contact. The ring may be rotated around the dial to place the index at any desired position, and it will

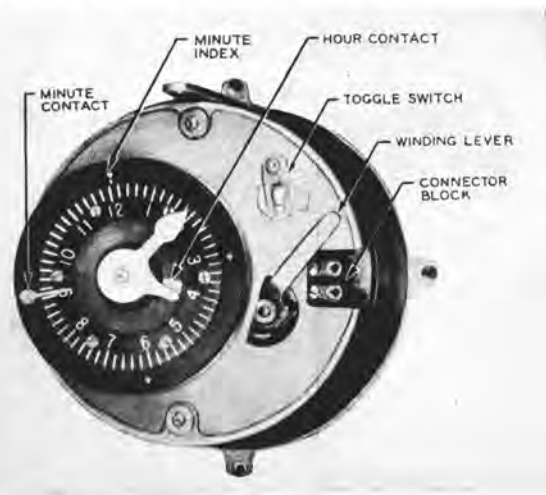

FIGURE 50. Waiting time clock.

be held in that position by friction. The contact will always be located 15 minutes (90 degrees) counterclockwise from the index. An electric connection of a few seconds' duration is made between the contact and a pin on the underside of the minute hand.

Another ring is located in the central hole in the dial. This ring also contains an index and a contact, and may be rotated as desired. This contact is simply a metal plate set flush with the surface of the ring. A spring wiper on the underside of the hour hand makes an electric connection to this contact when the hand is directly over it. Both hands and both contacts are gold-plated to assure low contact resistance.

In use, the inner index is set at the hour and the outer index at the minute that the sound program is to start. The hands are set at the correct time, and the clock is started by operating the toggle switch. Fifteen minutes before the time indicated by the indexes, the hands will both be at their contact points. In this position a continuous electric circuit is formed from one terminal of the connector block through the inner contact, the hour hand, the minute hand, the outer contact, and the toggle switch to the other terminal of the connector block. This 15-minute anticipation of the sound program allows time to elevate the loudspeaker.

RECORDER

The recorder is auxiliary equipment used to prepare the magazines by imposing the desired sound programs on their reproducers. It is substantially similar to the recorder employed for other Heaters described in Section 13.2.3. Other accessories, such as a microphone and test set, are also substantially similar.

INSTRUCTION BOOK

A book describing the Water Heater and containing instructions for testing, adjusting, and operating it has been prepared jointly by Bell Telephone Laboratories and General Electric Company.³ The book was written for personnel detailed for its particular operation without previous knowledge of the device. Thirty copies were delivered to the Bureau of Ordnance, U. S. Navy.

13.4.3 Operation of Acoustic System

PREPARATION OF MAGAZINE

Tactical considerations will determine the content and time schedule of the sound pro-

gram. This program must be recorded on the magazine of a Water Heater, and the program time controls must be set. This work is done at an operating base.

The magazine is mounted on the recorder. The entire length of wire is first erased to assure that no previously recorded signal will interfere with the program. The first 30 seconds of wire are recorded with some steady test sound derived from an oscillator, phonograph test record, or a whistle. The volume control is adjusted for this recording so that the electric eye volume indicator just closes. This produces a fully modulated wire. At the end of 30 seconds the volume control is turned to zero. The recorder is allowed to operate for a few seconds more and then is stopped. The next operation is to slide the first cam along the time bar (Figure 37) until it just operates microswitch S-8. The cam is locked in this position by its set screw.

The first section of the sound program is then recorded. The program material may be derived from a microphone pickup of "live" sounds such as speech, or from previously recorded sounds stored on phonograph disks, magnetic recorders, or similar devices. During the recording of the program, the volume control is adjusted so that the electric eye just closes on the peaks of the signal. At the end of this section of the program, the volume control is turned to zero, the recorder is stopped, and the second time cam is adjusted.

This procedure is repeated for each section of the program except the last. The reproducer has a capacity of 30 minutes' total recording time, and this may be divided into as many as ten sections. At the completion of the last section, no time cam is used. Instead, the stop collar is locked into position against the microswitch bracket. Pressure of the switch bracket against this collar will close switch S-5, and, at the end of the actual operation, this will explode the detonator.

When complete, the recording is rewound and then reproduced by utilizing the playback feature of the recorder. During this reproduction, the quality of the recording is observed, and any faulty portions are noted. These portions are then erased and recorded again. When fi-

nally judged satisfactory, the wire is rewound to the starting point, and the reproducer is ready for use.

The program clock on the end of the magazine is usually adjusted at the time the recording is made. The clock dial is rotated clockwise until the "start" mark is aligned with the operating lever of the microswitch. This position is shown in Figure 38. The operation automatically winds the clock. The central knob is then loosened so that the fingers projecting beyond the rim of the dial may be rotated. One of these fingers is set at the number of minutes after H hour that the first section of the sound program is to start. Other fingers are set at the times subsequent sections are to start, and any surplus fingers are stored in the space beyond 120 minutes. The knob is then tightened, locking all the fingers in position. The magazine is now ready for insertion in the mine.

ADJUSTMENT OF AMPLIFIER

After the magazine has been prepared, the cover is removed from the magazine handhole, and the magazine is inserted in the mine and latched in place on the reproducer drive. The test set is then connected to the test jack on the equipment rack. Toggle switch S-10 is now operated and push-button switch S-11 is closed momentarily. This operates the power relay and starts the system. Twenty seconds later the reproducer motor starts, and the 30-second test signal recorded at the start of the wire is reproduced. During this period, the amplifier volume control is adjusted so that 500 watts (47 volts) is delivered to the test set. At the end of 30 seconds the test signal stops; a few seconds later the microswitch on the reproducer will reach the first time cam, and the system will shut down automatically. The test set is then removed, the toggle switch restored to "off" if this has not been done previously, and the handhole cover is secured in place.

ADJUSTMENT BEFORE FIRING

The waiting time clock and the attenuator are set just before firing. Both of these are accessible through the port handhole in the afterbody. This location was chosen so that the adjustment may be made with only a short

length of the mine withdrawn from the firing tube. The clock indexes are set at the time the sound program is to start, the hands are set at the correct time at the moment of setting, and the clock is started.

The proper attenuator setting is governed by the anticipated sound transmission loss between the mine and the shore, and by the sound level that is desired on shore. The transmission loss is a complex function of distance and of atmospheric conditions, the most important conditions being wind speed and direction. The desired sound level on shore depends on the objectives of the operation. For deceptive purposes the optimum sound intensity level has been found to be about 15 db above the steady masking noise. These factors are discussed at length in reference 1 and have been summarized in Section 13.1. Table 4 shows the attenuator setting to produce 15 db above masking noise for sound programs transmitted over a range of distances under a variety of wind conditions. Some inaccuracy is tolerable because the transmission loss varies considerably from moment to moment. The transmission of intelligible speech requires a higher sound level on shore than do deceptive sounds. The attenuator should be set at step 9 (no attenuation) for this purpose, and the maximum range should be the distance specified in the table for step 7.

The proper attenuator setting is thus determined by a combination of the mission, the acoustic range, and predicted weather conditions. The attenuator is set at that point and the handhole secured. From this point on, the action of the acoustic and timing system is entirely automatic.

13.4.4 Performance of Acoustic System

The acoustic system of the Water Heater has an effective frequency range of 350 to 5,000 c. This is ample for the reproduction of speech and is adequate for the reproduction of many tactical sounds. However, those sounds which are rich in low-frequency components are not faithfully reproduced, and in deceptive warfare they must be used cautiously to avoid detection. In particular, the sound level on shore must be

kept low so that the observer is forced to strain to hear it. Under conditions of strain and of poor visibility, the observer's imagination will cause him to ignore deficiencies in the sound.¹

The maximum distance that the sound is effective depends upon the weather,¹ the wind speed and direction being the most important factors. This effect is shown by Table 4. Under favorable conditions the useful range is 6,000 yd, but under adverse conditions it may be reduced to as short as 1,000 yd. The effective spread of the sound is approximately ± 30 degrees from the sound axis.

13.4.5 General Assembly of Water Heater

The outline of the Water Heater is shown in Figure 51. Various parts are designated as follows:

- Section No. 1 Anchor, or nose assembly.
- Section No. 2 Speaker and elevator compartment.
- Section No. 3 Amplifier and battery compartment.
- Section No. 4 Afterbody, or propulsion equipment.

The complete unit weighs 2,700 lb, and when in salt water it has a negative buoyancy of 150 lb. After the anchor, which weighs 550 lb, has been dropped, the buoyancy becomes positive, and the Water Heater therefore floats to the surface. It will ride with its axis vertical because the loss of the nose weight shifts the center of gravity aft of the center of buoyancy.

Tests showed that a glide angle of approximately $2\frac{3}{4}$ degrees was desirable in order to maintain stability during the Water Heater's run. The Heater is therefore designed nose heavy with the center of gravity 135 in. from the aft end. It is trimmed by the addition of lead in either section No. 1 or section No. 4 or both. Throughout the design of the device, it was necessary to take special cognizance of the total and of the distribution of weight so that the completed unit could be trimmed by a small addition of weight.

Corrosion-resistant metals, plating, and tropicalization have been used throughout the equip-

ment whenever possible to provide protection against the salt atmosphere.

13.4.6

Component Parts

SHELL

The shell of the Mark 18 torpedo, being 21 ft long by 21 in. in diameter, was the largest of the

TABLE 4. Attenuator settings to produce 15 db above masking noise on shore.

Distance (yd)	Calm	Wind speed (knots)			
		1-3	3-6	6-12	12-22
		<i>Wind angle 0° to 90°</i>			
400	1	1	2	2	4
600	1	2	2	3	4
800	2	2	3	4	5
1,000	2	3	3	4	5
1,200	3	3	4	4	6
1,400	4	3	4	5	6
1,600	4	4	4	5	6
1,800	5	4	5	5	7
2,000	6	4	5	6	7
2,500	7	5	6	6	8
3,000	9	5	6	7	8
3,500		6	7	8	9
4,000		7	8	8	
5,000		8	9		
6,000		9			
		<i>Wind angle 135°</i>			
400		2	3	4	4
600		3	4	5	5
800		4	5	6	6
1,000		5	6	7	7
1,200		6	7	8	8
1,400		7	8	9	9
1,600		8	8		
1,800		8	9		
2,000		9			
		<i>Wind angle 180°</i>			
400		3	4	4	5
600		4	5	6	7
800		5	6	7	8
1,000		7	8	8	9
1,200		8	9		
1,400		9			

easily handled variety. It provided sufficient volume and buoyancy to house all of the contemplated components. Each section was made by wrapping $\frac{1}{16}$ -in. plate around pressed ribs and welding, with machined joint rings at the end for connection to the following section.

The position of handholes is critical since access must be made at the proper points.

POWER SUPPLY

The power requirements for propulsion for 15 minutes and for operation of the acoustic system for 30 minutes were calculated, and the Electric Storage Battery Co. provided a battery

weight of the entire battery assembly is approximately 500 lb.

The upending of the battery was made possible by using a large cap of special design, suitable for catching electrolyte, by the use of the proper quantity of electrolyte in relation to available space, and by careful calking of all joints. Tests showed that the battery supplied

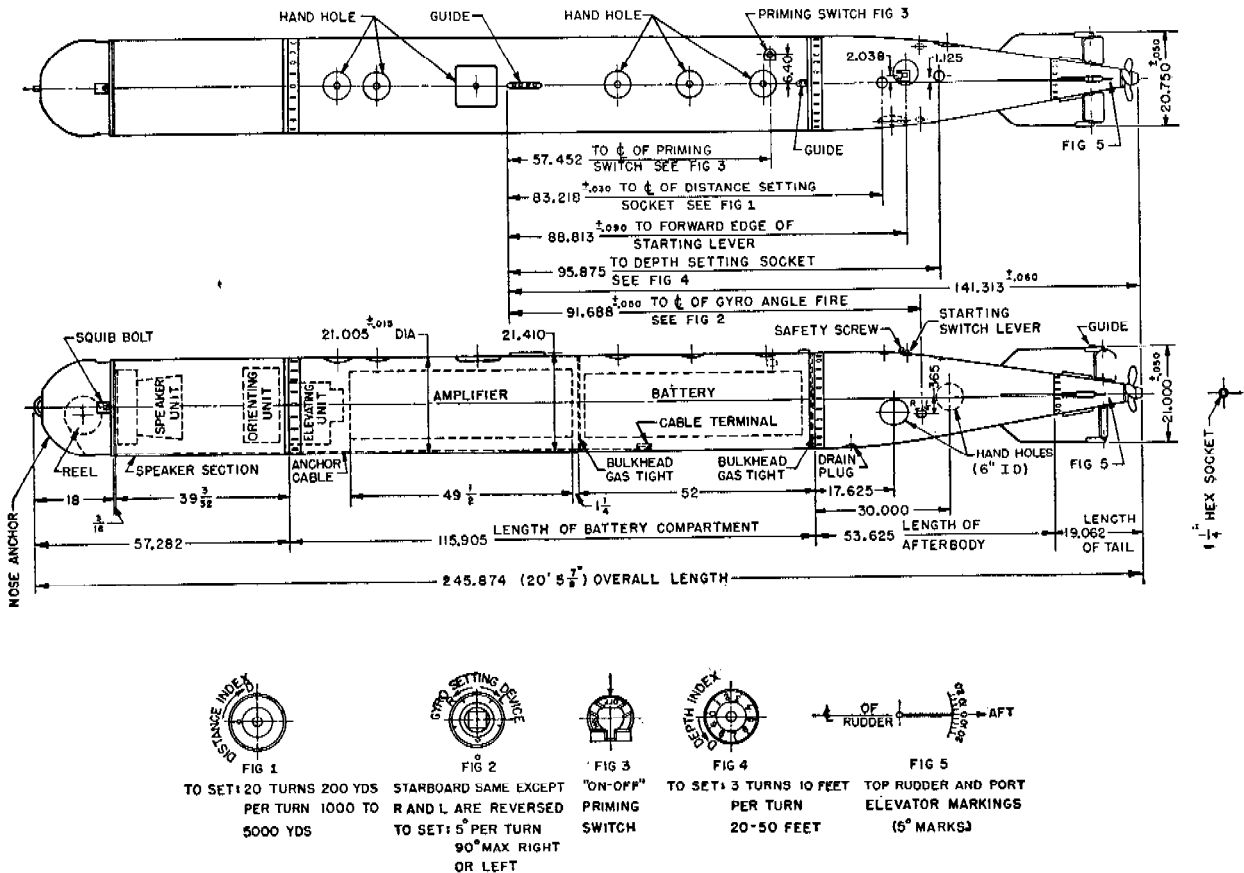

FIGURE 51. Water Heater outline.

in three sections capable of delivering the necessary power even in the upended position in which it must operate after the device has anchored itself. The three sections are connected in parallel during the period of propulsion and then switched by a series-parallel relay, developed especially for the job, to series connection for the remainder of the operation. The aft section has greater capacity than the other two to provide the additional control power needed for the afterbody controls. The

all the necessary power but with no safety factor.

PROPULSION EQUIPMENT

The propulsion equipment is part of the Mark 27 torpedo and is therefore described only briefly. It consists of firing switch, motor-starting relay, distance-gear, propeller shaft, and propeller. The firing switch is activated by a dog in the firing tube. The propulsion motor

is a 4-pole compound-wound, 7.75-hp, 1,800-rpm, d-c motor rated on a 15-minute special duty basis, requiring 103 amperes at 67 volts.

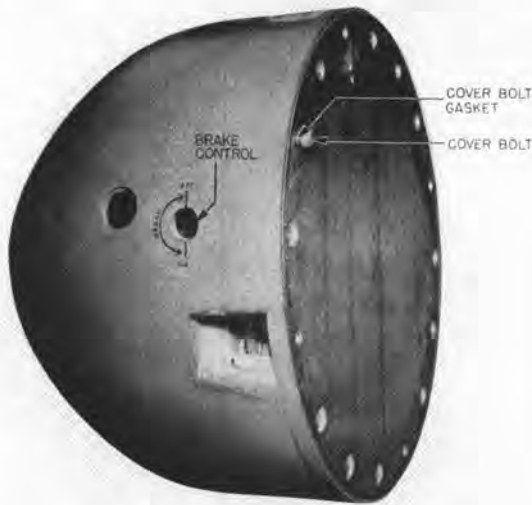

FIGURE 52. Anchor.

The control system governs the depth and direction of the run. Both functions operate on the selsyn principle, which yields small poten-

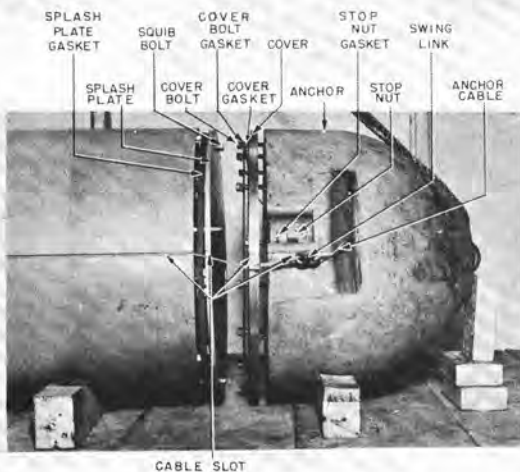

FIGURE 53. Anchor assembly to section No. 2.

tial differences that are proportional to the differences between the Water Heater's actual position and the predetermined control settings.

The depth control, located at the top of the afterbody shell, is set to the desired depth of run by means of a calibrated disk and index. Water pressure acting on the bellows of the

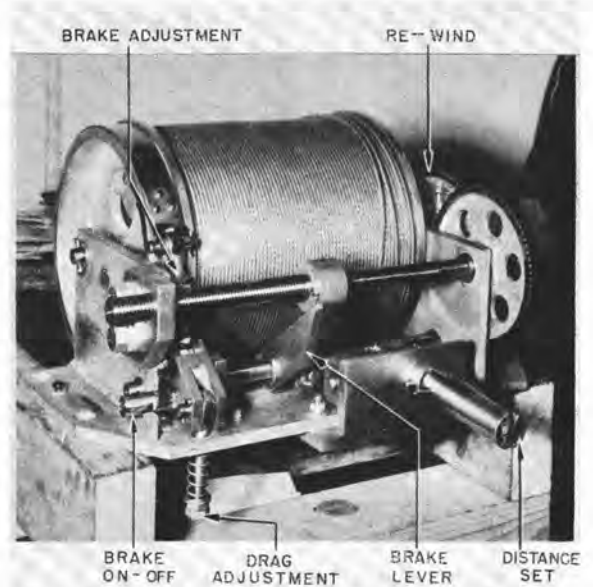

FIGURE 54. Anchor reeling mechanism.

depth control causes a rotation of the depth selsyn. A pendulum damping assembly prevents the Heater from plunging or rising too sharply.

The direction is controlled by a gyroscope set either for dead ahead or for an angle course. One of the windings of a selsyn is mounted on the gimbals of the gyroscope and the other on the stator. This selsyn is interconnected with



FIGURE 55. Squib bolt assembly parts.

another on the angle fire setting spindle. The upending of the Water Heater created a new problem since the sudden change of direction placed such a stress on the gyroscope that the motor shafting flexed enough to snap the armature leads. A special gyroscope was developed to withstand this unusual strain.

The error of direction may amount to ± 2.87

degrees. The error is caused by precession of the gyroscope during the time of traveling the course. A distance error of 100 yd or 5 per cent of the set distance, whichever is greater, results from using the number of screw revolutions with its inherent errors as the basis of determining the distance at which the propulsion motor is stopped.

ANCHOR

The anchoring mechanism consists of the anchor, shown in Figures 52, 53, and 54, and

to seal this plate against section No. 2. The whole assembly weighs 550 lb.

The anchor cable used is 1/8 in. in diameter

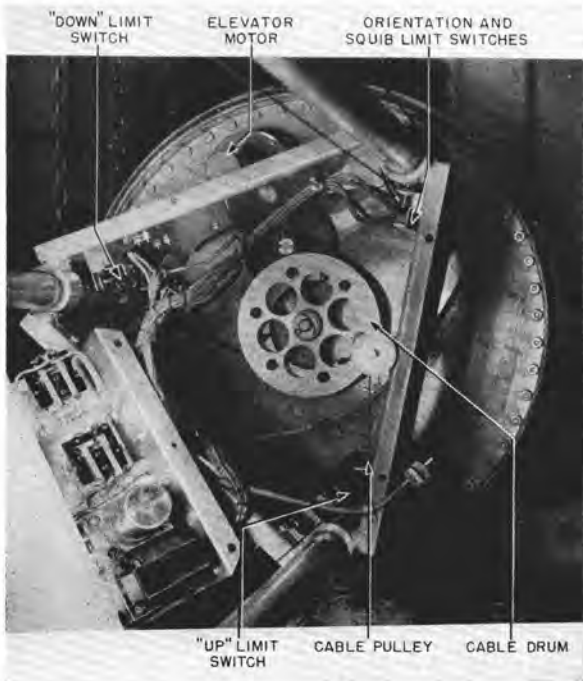

FIGURE 56. Elevator mechanism.

the explosive release bolts shown in Figure 55.

The release bolt consists of a steel block drilled to slide in a threaded boss far enough to pin it in place by a shear pin. A six-grain charge of powder, in the form of a squib, is placed behind the boss and, when detonated, expels the boss which is carried off by the falling anchor. In this way, a means of dropping anchor at any desired time is provided.

The anchor consists of an exterior iron casting, weighing 450 lb, a cable reel and its associated mechanism, shown in Figure 54, a cover plate to protect this mechanism, and a gasket

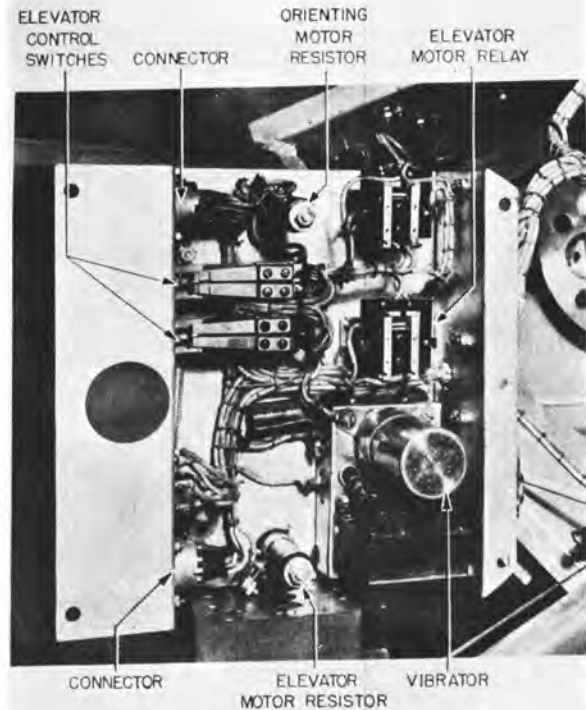

FIGURE 57. Elevator mechanism control panel interior.

and made of 19 strands of best cable steel. The cable is fastened to the Water Heater at about



FIGURE 58. Elevator mechanism control panel in place.

the center of section No. 3. The cable then passes through a groove in the shell, flush with the outside diameter, through a similar groove

in part of the anchor, through the pay-out slot, and onto the drum, where 1,000 ft of the cable is stored. Just before reaching the drum, however, the cable is spliced by a swing link, permitting the anchor cable to be detached from the Water Heater during recovery operations or for other reasons.

The drum is restricted by a brake band, which not only maintains a drag during unreel-

lected. The brake lever is set at 300, 600, or 900 ft of cable by an exterior adjustment. Rotation of this control slides the brake lever to the correct position.

ELEVATOR

The elevator mechanism is housed in section No. 2 and serves to hoist the orientation and loudspeaker equipment out of the shell for operation. It is shown in Figures 56, 57, and 58. The structure consists of a three-cornered cast-aluminum platform, below which three pipes are fitted and pinned. The three stainless-steel

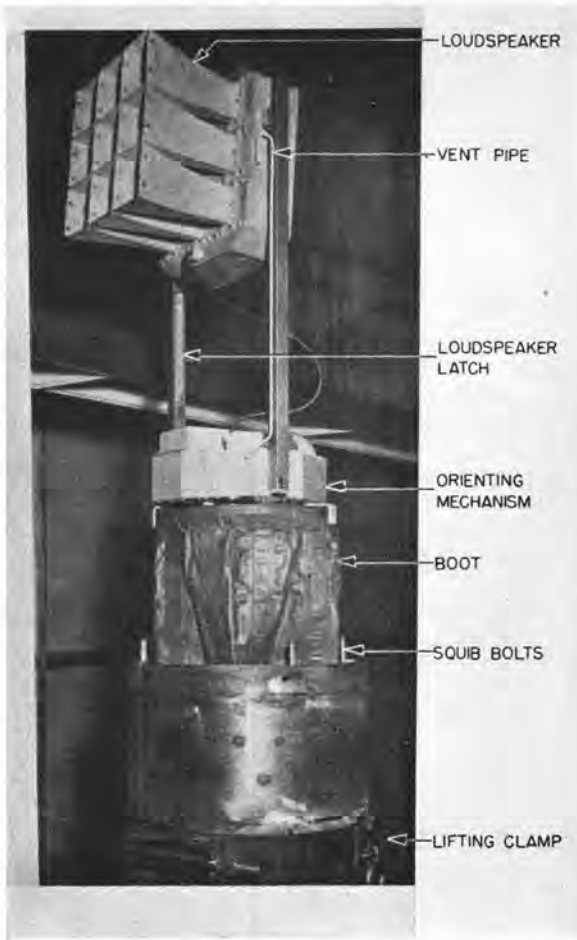

FIGURE 59. Loudspeaker fully raised.

ing, but also stops the pay-out at a set length of cable. This stop is effected by a gear train from the drum to a lead screw which advances 1 turn for every 16 turns of the drum. On the lead screw is a cam, and, when this cam comes in contact with a stationary brake lever, a series of linkages tightens the brake band on the drum and unreeling stops at the length se-

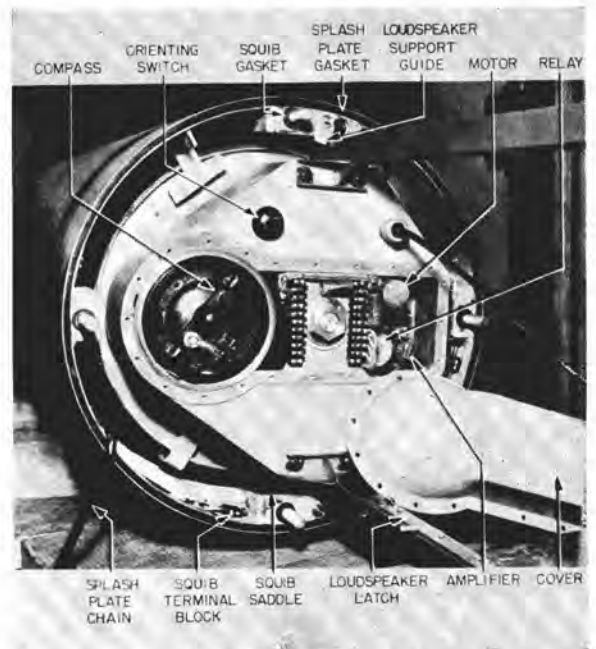

FIGURE 60. Orienting mechanism with cover off.

pipes pass through bearings held by a plate bolted to the inside of the shell in such a way that, when the pipes are lifted from below, the whole assembly is free to rise. It is held in the vertical position by double bearings.

The hoisting apparatus consists of a small 24-volt d-c motor with a gear reduction which drives a drum. Three separate $\frac{1}{16}$ -in. steel cables are fixed to this drum and pass over respective pulleys at the three pipe bearing points, thence down over pulleys at the bottom of each pipe, and back up to the fixed bearing points. When the drum rotates, each cable is wound

equally on the drum, thereby shortening the cable and raising each of the three pipes simultaneously. The elevator is lowered by reversing the d-c motor and consequently unreeling cable from the drum. Initial tension on each cable is adjusted by a movable eye at the fixed end of each cable.

Notches are cut in each pipe to operate limit switches at various positions of the elevator, and a mechanical lock is automatically engaged

performed before and during the curing cycle so that it tends to keep against the shell and away from the elevator. A restricted breather (Figure 59) relieves the vacuum created within the shell as the elevator rises. (The pressurizing intake is placed forward of the boot so that the pressurizing aids in forcing it well down before launching.)

The platform also has a boss and bearing surface at its center for the support of the orienting mechanism. This serves as the fulcrum for the rotation of the loudspeaker and, although above the rubber boot, is watertight at the bearing surfaces.

ORIENTATION MECHANISM

The orientation mechanism (Figure 60) causes rotation of the loudspeaker support with respect to the boss on the platform. Power connections are made through slip rings mounted at the center bearing. Orientation is based on a magnetic compass. The accuracy of the compass is impaired by stray magnetic fields from the loudspeaker and by the declination, so that an error of ± 10 degrees must be anticipated. A calibration chart made for each Heater at a given location will allow accurate correction, but for normal operating conditions the 10-degree error is tolerable since the sound beam spreads over a 60-degree angle and is moderately effective throughout a sector of 120 degrees. The compass assembly is shown in Figure 61. When the compass drum at the control panel is rotated, the whole compass assembly rotates correspondingly. (An automatic stop prevents more than one complete turn, thereby protecting the wiring against fouling.)

The compass needle consists of a circular disk in which a slot has been cut at the outer edge on an arc of about 90 degrees. This slot lines up with a beam of light projected from a Mazda lamp on the outside top through a lens, and, when the slot is directly below this beam, the beam passes through, then through another lens at the bottom of the compass bowl, and falls upon a photocell. The magnetic card remains in a fixed direction. If the compass bowl moves far enough, the light will not line up with the slot, and light is cut off from the photocell.

The photocell is used to control the bias on a



FIGURE 61. Orienting mechanism compass assembly.

when the elevator is fully raised to prevent lowering during operation.

The upper portion of the platform carries a circular disk slightly smaller in diameter than the shell, to which is attached a flexible cylindrical rubber boot. The lower end of the boot is fastened to a ring on the inside of the shell midway in the elevator platform's travel. The boot is sealed with cement, top and bottom, thereby making a watertight barrier to the interior of the Heater and yet allowing the elevator to travel up and down. The material of the boot is

6J5 tube so that plate current flows when the cell receives light, and is cut off when the light is cut off. The plate current is in turn used to activate a sensitive relay which is normally closed but has a double-throw contact arrangement. Thus, if light reaches the photocell, the relay is closed in one direction, and if light is cut off, it closes in the opposite direction.

This relay action is utilized to control a small 24-volt d-c motor which is mounted on the orientation box but is geared to the aluminum platform on the elevator. Operation of the motor revolves it and the entire mechanism around the bearing at 7.5 degrees per second.

The design of this circuit requires that the motor always be operating either in one direction or the other, resulting in a constant hunting action of 2 degrees. This will occur about one edge of the slot in the compass card, giving an on-off light to the photocell. Polarity of the d-c driving motor is therefore important, for, if reversed, hunting will immediately take place at the other end of the slot and therefore point the loudspeaker about 90 degrees away from the desired setting.^b

DISPOSAL UNIT

A circuit has been provided to detonate an explosive after the completion of the acoustic program. The explosive consists of plugs of TNT held by brackets against the shell of the amplifier section. Following the recommendations of the Naval Ordnance Laboratory, a Mark 1 booster plus a Mark 143 fuze are both housed together in a cylinder. The Mark 143 fuze contains both an arming circuit and a firing circuit. The arming circuit is closed by the waiting time clock at the time the elevator starts. Thus the charge becomes armed only after reaching its destination. The firing circuit is interlocked to prevent premature firing. Before reaching the time switch on the reproducer, the circuit must be closed by the operation of the distance switch in the afterbody (i.e., after the Heater has reached its destination) and also through a "test" plug which is operated by personnel before launching.

^b The manufacturer of the compass has expressed the opinion that, for further production, they would prefer to develop a special compass which would materially simplify the present construction.

The amount of TNT employed is sufficient to blow a hole in the side and let the Water Heater sink.

PINGER

To facilitate recovery of the Water Heater during tests when it might accidentally sink to the bottom, a pinger is mounted in the main battery compartment. It is turned on at the time the priming switch is operated. It consists of a 45-kc oscillator and a crystal-type hydrophone for transforming the electrical pulses into mechanical vibrations. The pinger operates on its own batteries within its watertight case and will operate for several days. The mechanical vibrations can be detected by a diver or surface craft and are a very effective guide to recovery.

LEAKAGE CONTROL

Before launching the Water Heater, it is pressurized through the inlet in the anchor and soap-water is applied to all joints and handholes. Leaks are thus discovered, and also the rubber boot is pushed down to its proper position.

At the moment of dropping anchor, the entire orienting mechanism is exposed to the water except for the splash plate. This plate is reasonably watertight, but is not a bulkhead since it has to be pushed off by the elevator as it rises. The time required for rising to the surface after dropping anchor is less than 10 seconds, however, and only a small amount of water is shipped. Nevertheless, on upending, this water is caught in the cavity and may seep through various bearings in the elevator and must therefore be caught. A sump has been provided to do this, with a drain cock for emptying when reconditioning.

13.4.7

Operation

When all controls have been set, reproducer magazine installed, handholes closed, and the entire device tested for leaks by pressurizing, the Water Heater may be fired from a conventional submerged tube. Two minutes before actual firing, however, the priming switch (Figure 51) must be rotated to "on."

With the closing of the priming switch, the pinger is turned on, and the gyro in the afterbody starts. The gyro will reach normal speed in the 2 minutes' delay before firing.

As the torpedo leaves the firing tube, a dog in the tube operates the firing switch (Figure 62). This switch releases the gyro lock, thereby freeing the rotating element of its support, energizes the series-parallel battery relay, and closes the main propulsion motor relay.

The device then travels to a spot determined by the control settings. At this point, the revolution counter on the shaft operates the distance switch which stops the propulsion gear, ener-

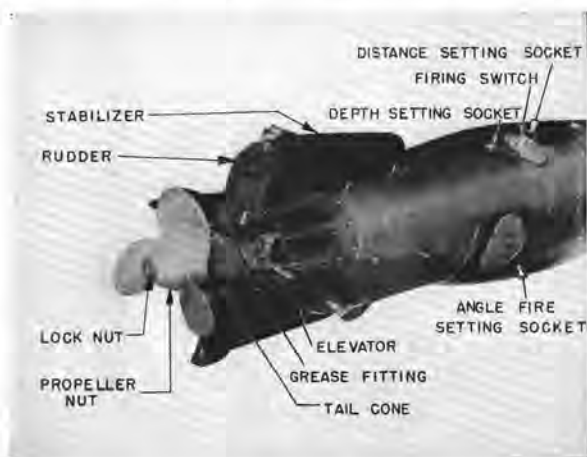

FIGURE 62. Afterbody interior.

gizes the explosive release bolts at the anchor, turns elevators to "hard-up," and deenergizes the series-parallel relay on the main battery.

The anchor falls off the nose when the four squib bolts explode and pays out cable as it falls. When this weight is lost, the remainder of the Water Heater becomes positively buoyant and floats to the surface, where it remains anchored and floating vertically with about 3 ft of freeboard above the water's surface. Intake of splash water is prevented by the splash plate.

At the set hour for performance, the waiting time clock in the afterbody makes contact and starts the elevator motor and the program clock on the recorder magazine. It also energizes the solenoid circuit of the disposal unit, thereby priming it ready for detonation. The elevator motor then operates the cable drum

and lifts all three elevator rods, pushing off the splash plate and starting the assembly upwards. As the elevator rises, a vacuum is produced within the rubber boot fastened between the elevator and shell, but this is relieved by the vent shown in Figure 59. This partial vacuum assists in keeping the boot drawn downward and hence out of the way of the elevator as it rises.

When the elevator has risen high enough, a trip mechanism (see Figure 59) allows the loudspeaker to fall free in its bearings and point in the horizontal direction. Slightly higher in the elevator's course, the 24-volt power is applied by the first limit switch which falls into a notch in one of the elevator rods. This energizes the vibrator (high-voltage supply) and the orienting motor. The same limit switch, being double-throw, opens one of the squib lines. A small increase in elevation trips a second limit switch when it falls into the same notch on the elevator rod. This applies 12-volt power to the Mazda lamp on the compass control. This limit switch also opens the other squib lead. The elevator then continues to rise to its full height, when a third limit switch opens the relay to the elevating motor and elevation ceases. Also at this time the mechanical lockup (Figure 58) snaps into place and prevents the elevator from slipping back down.

Fifteen minutes after the waiting time clock has closed, and independent of the elevator procedure, the program clock on the recorder magazine (started when the waiting time clock closed its contacts) starts the acoustical system by closing the main relay (see Figure 34). This starts the dynamotors, applies filament power, and also energizes the delay relay which subsequently starts the wire recorder. The output from the amplifier then travels through the attenuator in the afterbody and back up through slip rings in the orientation mechanism to the loudspeaker. For 2 hours the program clock governs the production of sound previously recorded on the wire recorder. During quiet periods the clock shuts off the main relay, deenergizing all audio equipment, but orientation continues.

When 2 hours have elapsed, the program clock closes S-5 and energizes the detonator,

which, if attached, blows a hole in the side, and the Water Heater sinks.

13.5 TACTICAL CONSIDERATIONS

The process of deceiving the enemy's ears is not an exact science, but great strides have been made toward removing the guesswork from it. In moving rapidly toward combat with sonic equipment patterned after the early NDRC model, the Navy showed strong confidence in their ability to deceive the enemy by suggestive caricature of sounds of military interest.

One important factor bearing upon this question is the effect of battle strain on the acumen of an observer. Reliable data on this can be provided only by the accumulation of observations made in actual combat zones, and such information is not available for this report. However, the importance of strain in the creation of illusions is an elementary psychological fact. Such errors of perception are less likely to occur when the sound is loud and sustained for then it is more readily identified. It is only when the exciting stimulus is vague that the imagination is given free rein.

Another well-known psychological fact of interest in deception is the association of stimuli received through several senses, for example, sight and hearing. If one is accustomed to both seeing and hearing a group of boats, he will, upon hearing such sounds and looking in the direction from which the sounds come, believe he sees the boats although there is actually not enough light to do so. Therefore, an observer, under the strain of impending attack and under conditions of poor visibility, such as moonlight or dawn, will transform a suggestive noise, faintly heard, into a strong illusion of a concentration of enemy forces and may firmly believe that he sees as well as hears them.

Cognizant of the limitations of the early equipment, the Navy took full advantage of

these psychological factors in the development of their tactics. In particular, they make the sound sporadic and keep it at a level that forces the observer to strain to hear it. Good use is made of the old theatrical adage that "the most profound noise is silence." Straining gaps of silence are, therefore, important parts of their tactics of sonic deception. Any attempt at sustained deception might prove its undoing. As a result, deceptive operations with the early equipment must be confined to an alerting action. An attempt to confirm an attack by sonic means might well be suicidal.

Both the Army and the Navy have been moving progressively toward equipment which permits a greater flexibility in tactics. The major improvements involve closing the gap between the performance of the first Heaters and the minimum requirements for comprehensive sound deception established by the combined Army, Navy, and NDRC work. High-powered high-fidelity systems can, when properly used, provide a sonic illusion of a complete attack sequence (excluding the simulation of fire). With faithful reproduction much less dependence is placed on an observer's imagination, and continuous sound programs become feasible.

The subject of associated deceptive measures is not covered by this work, although, in conjunction with the Army Experimental Station, several tactical problems have been worked out with supporting deception from other sources. These include smoke screens, explosions, live fire, and visual deception. Anything is useful that will force an observer to place greater dependence upon his ears or that will offer him some confirmation of what he thinks he hears.

Sonic deception in conjunction with other deception devices is not intended to replace the usual phases of a military feint. Its value lies in its intelligent use in support of such feinting operations.

GLOSSARY

HR. Hays carbon dioxide recorder.

LNR. Leeds and Northrup carbon dioxide recorder.

ORSAT. A portable gas-analysis apparatus which consists of a measuring buret and three or four gas-absorption pipets connected by a manifold.

Q. A figure of merit for a circuit, proportional to the ratio of the energy stored to the energy dissipated per cycle.

RR. Ranarex carbon dioxide recorder.



BIBLIOGRAPHY^a

Numbers such as Div. 17-310-M1 indicate that the document listed has been microfilmed and that its title appears in the microfilm index printed in a separate volume. For access to the index volume and to the microfilm, consult the Army or Navy agency listed on the reverse of the half-title page.

Chapter 1

DEPARTMENT OF TERRESTRIAL MAGNETISM

1. [Development and Test of Magnetic Compasses and Odographs in Vehicles], A. G. McNish, James M. Barry, Bryant Tuckerman, and others, OSRD 1398, Progress Report on Contract NDCre-187 for the Period June 30, 1942 to February 28, 1943, Carnegie Institution of Washington, Feb. 28, 1943. Div. 17-310-M1
 - 1a. *Ibid.*, Figures 1 through 10.
 - 1b. *Ibid.*, Report on Tests of June 3 to August 25, 1942, on Odograph Installation in Light Tank, Sept. 7, 1942.
 - 1c. *Ibid.*, Report on the Odograph Installation in Medium Tank M4A1E2 No. 6, Sept. 23, 1942.
 - 1d. *Ibid.*, Report on the Odograph Installation in B-18-B Army No. 7561, Oct. 8, 1942.
 - 1e. *Ibid.*, Report on the Demonstration of Odograph in Aeroplane on October 9, 1942, Oct. 10, 1942.
 - 1f. *Ibid.*, Memorandum on Odograph Tests at Fort Knox in Medium Tank M4A1E2, Feb. 22, 1943.
 - 1g. *Ibid.*, Land, Sea, and Air Logs, Feb. 28, 1943.
 - 1h. *Ibid.*, Report on Installation of an Odograph in B-24D Bomber, Feb. 28, 1943.
2. Report on Trip to England, November 12, 1942 to February 1, 1943, including Demonstration of the Odograph, British Aircraft Compasses, British Vehicular Compasses, British Dead-Reckoning Devices, and British Marine Logs, Bryant Tuckerman, OSRD 1470, Service Project NDCre-187, Carnegie Institution of Washington, Mar. 31, 1943. Div. 17-313.12-M1
3. Tests of Odograph in Halftrack, Fort Belvoir, Virginia [Report Covering Period from], April 8, 1943 to May 5, 1943, James M. Barry, OSRD 1614, Service Project NDCre-187, Carnegie Institution of Washington, June 15, 1943. Div. 17-313.12-M3
4. Report on Installation of Odograph in T-15 Cargo Carrier [Report Covering Period from], January 6 to March 15, 1943, J. L. Dalke, OSRD 1613, Service Project NDCre-187, Carnegie Institution of Washington, June 19, 1943. Div. 17-313.12-M4
5. Tests of Odograph in M-29 Cargo Carrier, Cargo-Carrying Sled, and Special Trailer [Report Covering Period from], October 26, 1943 to January 7, 1944, James M. Barry, OSRD 3340, Service Project NDCre-187, Carnegie Institution of Washington, Apr. 1, 1944. Div. 17-313.12-M5
6. Tests of Odograph in a 2½-Ton Amphibious Truck, James M. Barry, OSRD 4239, Service Project NDCre-187, Carnegie Institution of Washington, May 16, 1944. Div. 17-313.12-M6
7. Installation of Aerial Odograph in OA10 43-43843, William Finley Wright, E. S. Hughes, and A. G. McNish, OSRD 3785, Service Project NDCre-187, Carnegie Institution of Washington, June 10, 1944. Div. 17-313.11-M1
8. Tests on Aerial Odograph in PBM-3S, No. 01677 [During the Period from], December 10, 1943 to January 28, 1944, at U. S. Naval Air Station, Quonset Point, R. I., Vaughn L. Agy, OSRD 3795, Service Project NDCre-187, Carnegie Institution of Washington, June 12, 1944. Div. 17-313.11-M2
9. Report on Tests of Aerial Odograph in RA-29 at Wright Field, Dayton, Ohio, from February 2, 1944 to April 13, 1944, Vaughn L. Agy, OSRD 3805, Service Project NDCre-187, Carnegie Institution of Washington, June 14, 1944. Div. 17-313.11-M3
10. The Department of Terrestrial Magnetism Marine Speedometer, R. J. Duffin, OSRD 3338, Service Project NDCre-187, Carnegie Institution of Washington, June 30, 1944. Div. 17-323.51-M1
11. A 400-Cycle Inverter for Operating a Magnesyn Remote-Indicating Compass from 110 Volts Alternating Current or Direct Current, Bryant Tuckerman and Max Malin, OSRD 4240, Service Project NDCre-187, Carnegie Institution of Washington, Sept. 16, 1944. Div. 17-314-M1
12. The Step Writer, R. J. Duffin, OSRD 4731, Service Project NDCre-187, Carnegie Institution of Washington, Feb. 28, 1945. Div. 17-313.3-M2
13. The Pedograph, J. L. Dalke, OSRD 4730, Service Project NDCre-187, Carnegie Institution of Washington, Feb. 28, 1945. Div. 17-313.3-M1
14. Magnetic Fields of Tanks and Other Vehicles, A. G. McNish, Bryant Tuckerman, Vaughn L. Agy, and James M. Barry, OSRD 4734, OEMsr-151, Service Project OD-46, Carnegie Institution of Washington, Feb. 28, 1945. Div. 17-122.2-M1
15. The Vehicular Odograph, A. G. McNish, Bryant Tuckerman, and Vaughn L. Agy, OSRD 4965, Service Project NDCre-187, Carnegie Institution of Washington, Apr. 10, 1945. Div. 17-313.12-M7
 - 15a. *Ibid.*, pp. 29-41.
 - 15b. *Ibid.*, p. 35.
 - 15c. *Ibid.*, p. 39.
 - 15d. *Ibid.*, p. 24.
16. Final Report on Contract NDCre-187 and Supplements, J. A. Fleming and A. G. McNish, OSRD

^aThis list includes all material consulted in the preparation of this report. Specific references in the report do not necessarily include all items.

- 4997, Service Project NDCrc-187, Carnegie Institution of Washington, Apr. 27, 1945. Div. 17-310-M2
17. *True Air Mileage Devices*, William Finley Wright, Vaughn L. Agy, and E. S. Hughes, OSRD 5016, Service Project NDCrc-187, Carnegie Institution of Washington, Apr. 28, 1945. Div. 17-313.2-M1 17a. *Ibid.*, p. 10.
18. *Letter to William H. Crew* [on Magnetic Compasses], *Memorandum on Work Conducted at the Department of Terrestrial Magnetism, Carnegie Institution of Washington, under Division C3* (Photographs Attached), J. A. Fleming, Service Project NDCrc-187, Carnegie Institution of Washington, Oct. 2, 1945. Div. 17-310-M3

GENERAL MOTORS CORPORATION

19. *Demagnetizing Military Vehicles*, Wayne T. Sproull, Preliminary Report PI-77, Project PI-4-R, Jan. 12, 1943. Div. 17-315-M1
20. *The Development and Tests of an Inductor Compass*, C. E. Grinstead, OSRD 3002, OEMsr-1121, Report PI-104, Nov. 18, 1943. Div. 17-312-M1
21. *Tests of Magnetic Eraser for Military Vehicles at Proving Grounds and at Washington, D. C.*, Wayne T. Sproull, OSRD 3202, OEMsr-1121, Report PI-99, Jan. 5, 1944. Div. 17-315-M2
22. *The Development and Tests of an Inductor Compass* [covering period from], *December 1943 to May 1944*, C. E. Grinstead, OSRD 4196, OEMsr-1121, Progress Report PI-119, Aug. 31, 1944. Div. 17-312-M2
23. *Inductor Compass Tests on an M-3A1 Light Tank, June to July 1944*, C. E. Grinstead, OSRD 4517, OEMsr-1121, Report PI-123, Nov. 15, 1944. Div. 17-312-M3
24. *The Design and Development of the Inductor Compass*, C. E. Grinstead, OSRD 5064, OEMsr-1121, Summary Report PI-131, May 23, 1945. Div. 17-312-M4
- 24a. *Ibid.*, pp. 3-5.

INTERNATIONAL BUSINESS MACHINES CORPORATION

25. *Airborne Odograph, Preliminary Bulletin on Model A0-3, Operation and Compensation*. Div. 17-313.11-M6
26. *Airborne Odograph*, Alfred B. Benson, OSRD 5396, OEMsr-426, July 31, 1945. Div. 17-313.11-M5
27. *Development Report, Land Odograph*, W. W. McDowell, C. D. Lake, and G. F. Daly, OEMsr-426, NDRC Research Project PDRC-641, April 1943. Div. 17-313.12-M2

MISCELLANEOUS

29. *Aircraft Compasses, Operation and Flight Instructions for Gyro Flux Gate Compass*, Technical Order 05-15-27, Jan. 31, 1944.
30. *Gyro Stabilized Flux Gate Compass System, Handbook of Operation and Service Instructions AN 05-15-16*, April 15, 1944, Revised May 20, 1944. Div. 17-311-M2
31. *Air Position Indicators and Associated Components*, J. P. Palmer and W. F. Wright, Radiation Laboratory Report 63, MIT, June 18, 1944.
32. *Pioneer Gyro Flux Gate Compass System, Operations and Service Instructions*, Report 45-16D, Bendix Aviation Corporation, 1944. Div. 17-311-M1
33. *The Air Mileage Unit*, S. D. 0342. (Photostat)
34. *Operating Instruction Manual, War Department Technical Manual TM-5-9411*, Prepared by International Business Machines Corporation.
35. *Operating Instruction Manual, War Department Technical Manual TM-5-9401*, Prepared by Monroe Calculating Machine Company. 35a. *Ibid.*, pp. 53-64.
36. *Odograph Installations in Ferrets Nos. 7 and 8* [in the] *Southwest Pacific Area*, Frank F. Weber and William Finley Wright, Technical Observers, Section 22, U. S. Army Air Forces, General Headquarters, Southwest Pacific Area, Revised Nov. 4, 1944. Div. 17-313.11-M4

Chapter 2

1. *Synchronization of Photoflash Bombs*, Allen A. Walsh, C. W. Turner, and E. Dudley Goodale, OSRD 3626, OEMsr-1256, Service Project OD-141, NBC, June 15, 1944. Div. 17-323.4-M1
2. *Synchronization of Photoflash Bombs*, Allen A. Walsh and J. Lewis Hathaway, OSRD 4893, OEMsr-1256, Service Project OD-141, NBC, Mar. 20, 1945. Div. 17-323.4-M1
3. *Synchronization of Photoflash Bombs* (Final Report), Allen A. Walsh and J. Lewis Hathaway, OSRD 5675, OEMsr-1256, NBC, Sept. 24, 1945. Div. 17-323.4-M2
- Buckley Field Tests* [of] *T-58 Fuze Equipment* (Supplementary Report), Allen A. Walsh, J. Lewis Hathaway, and Vernon J. Duke, OSRD 5675, OEMsr-1256, NBC, Oct. 31, 1945. Div. 17-323.4-M3
4. *Characteristic Sheet of Mechanical Time Arming Delay, T4*, O.P. No. 3589, Aberdeen Proving Ground, Aberdeen, Md., July 6, 1945.
5. Aberdeen Proving Ground Firing Record B-8934, with APG Photograph A-28047; June 12, 14, and 15, 1945.
6. *Static Synchronization Tests of T58 Fuze and M46 Photoflash Bomb*, Aberdeen Proving Ground, Aberdeen, Md., August 1945.

Chapter 3

1. "The Oximeter, an Instrument for Measuring Continuously the Oxygen Saturation of Arterial Blood in Man," Glenn A. Millikan, *Review of Scientific Instruments*, Vol. 13, No. 10, October 1942, pp. 434-444.
2. "Improved Form of Sensitive Relay," Victor Legallais, *Review of Scientific Instruments*, Vol. 14, No. 1, January 1943, p. 51.
3. *Oxygen-Want Indicator and Flight Research Oximeter*, OSRD 1643, OEMsr-12 and OEMsr-544, University of Pennsylvania and Central Scientific Company, Jan. 1, 1944. Div. 17-321-M1
4. *Oxygen-Want Indicator*, K. H. Booty, OSRD 3854, OEMsr-544, Central Scientific Company, July 31, 1944. Div. 17-321-M2
5. *Oximeters for Use in Aircraft*, Glenn A. Millikan, OSRD 6429, OEMsr-12, University of Pennsylvania, January 1946. Div. 17-321-M3
 - 5a. *Ibid.*, p. 10.
 - 5b. *Ibid.*, pp. 19-21.
 - 5c. *Ibid.*, p. 30.
 - 5d. *Ibid.*, pp. 32-34.
4. *An Acoustic Volume-Measuring Device*, W. Caywood, OSRD 5166, OEMsr-1234, Carnegie Institute of Technology, May 31, 1945. Div. 17-322.1-M4
 - 4a. *Ibid.*, pp. 16-18.
5. *Aircraft Fuel Quantity Gauge (Parts I and II)*, William G. Fastie and Joseph Razek, OSRD 5672, OEMsr-178 and OEMsr-266, Johns Hopkins University and Gulf Research and Development Company, Oct. 31, 1945. Div. 17-322.1-M5
 - 5a. *Ibid.*, pp. 1-13.
 - 5b. *Ibid.*, pp. 14-72.
 - 5c. *Ibid.*, pp. 73-79.
6. *Some Characteristics of Aircraft Engine Fuels, Their Influence on Capacitor-Type Tank Gauges*, Paul G. Exline and J. W. Dashiell, OSRD 4016, OEMsr-266, Gulf Research and Development Company, June 30, 1944. Div. 17-322.1-M3
 - 6a. *Ibid.*, pp. 8-9.
 - 6b. *Ibid.*, p. 30.

Chapter 6

Chapter 4

1. *Radio Time Comparator*, W. F. Priest, OEMsr-1448, OSRD 5042, Hughes Aircraft Company, September 1945. Div. 17-323.81-M1
2. *The XA-2 Zenith Camera*, George H. Bateman, Peter Krause, J. Carroll, and M. Glicken, U. S. Army Air Forces Computation Section, 7th AAF Geodetic Control Squadron, 311th Reconnaissance Wing, Buckley Field, Colorado, November 1945. Div. 17-452-M1
 - 2a. *Ibid.*, p. 21.

Chapter 5

1. *Review of Methods of Measuring the Contents of Fuel Tanks*, F. Postlethwaite, OSRD Liaison Office II-5-7409(S), Technical Note Inst-756, Royal Aircraft Establishment, Great Britain, March 1943. Div. 17-322.1-M1
2. *Simmonds Capacitor Fuel Contents Gauge*, G. E. Bennett and E. C. Voss, OSRD Liaison Office II-5-7408(S), Technical Note Inst-757, Royal Aircraft Establishment, Great Britain, March 1943. Div. 17-322.1-M2
3. *Development of Electric Frequency Meter or Tachometer*, L. L. Nettleton, OEMsr-266, Final Progress Report D3-264, Gulf Research and Development Company, Aug. 10, 1942. Div. 17-323.82-M1
1. *Combustion Efficiency Indicator Investigation*, W. E. Stephens, OEMsr-267, Progress Report D3-258, University of Pennsylvania. Div. 17-322.2-M9
2. *Combustion Control*, Carl S. Carlson, OEMsr-267, University of Pennsylvania. Div. 17-322.2-M1
3. *An Instrument for Measuring Combustion Efficiency*, Carl S. Carlson, OEMsr-267, Progress Report D3-296, University of Pennsylvania, Oct. 3, 1942. Div. 17-322.2-M2
4. *An Instrument for Measuring Combustion Efficiency*, Carl S. Carlson and Miller J. Sullivan, OEMsr-267, Progress Report D3-335, University of Pennsylvania, Dec. 1, 1942. Div. 17-322.2-M2
5. *The Development of an Instrument to Increase Combustion Efficiency*, Carl S. Carlson and Miller J. Sullivan, OSRD 1237, OEMsr-267, University of Pennsylvania, Feb. 1, 1943. Div. 17-322.2-M3
6. *The Development of an Instrument to Increase Combustion Efficiency*, Carl S. Carlson and Miller J. Sullivan, OSRD 1471, OEMsr-267, University of Pennsylvania, Apr. 1, 1943. Div. 17-322.2-M4
7. *The Development of an Instrument to Measure Combustion Efficiency Aboard Naval Vessels*, Carl S. Carlson and Miller J. Sullivan, OEMsr-267, University of Pennsylvania, June 1, 1943. Div. 17-322.2-M7
8. *Studies and Experimental Investigations in Connection with the Development of an Instrument for Use in Measuring Combustion Efficiency in Naval Vessels*, Carl S. Carlson and Miller J. Sullivan, OSRD 3144, OEMsr-267, University of Pennsylvania, Nov. 30, 1943. Div. 17-322.2-M8
 - 8a. *Ibid.*, Appendix 5.
 - 8b. *Ibid.*, pp. 15-18, and Appendix 2.
 - 8c. *Ibid.*, pp. 18-20 and Appendices 3 and 4.

Chapter 7

1. *Supersonic Signalling*, Harold K. Schilling, OSRD 4219, OEMsr-1210, Service Projects SC-105 and 17.3-21, Pennsylvania State College, Sept. 18, 1944. Div. 17-436.45-M1
2. *Supersonic Signalling in the Tropics*, Harold K. Schilling, OSRD 4496, OEMsr-1210, Service Projects SC-105 and 17.3-21, Pennsylvania State College, Dec. 16, 1944. Div. 17-436.45-M2
3. *Ultrasonic Signalling*, Harold K. Schilling, OSRD 5012, OEMsr-1210, Service Projects SC-105 and 17.3-21, Pennsylvania State College, Mar. 31, 1945. Div. 17-436.45-M3

Chapter 8

1. *Energy Distribution in Machine Gun Sounds*, J. P. Maxfield, OSRD 1727, OEMsr-498, Service Project SC-27, Bell Telephone Laboratories, July 21, 1943. Div. 17-422-M1
2. *The Character of Sounds from Army Vehicles*, F. K. Harvey, G. F. Hull, Jr., R. T. Jenkins, J. B. Kelly, and N. G. Wade, OSRD 4254, OEMsr-498, Service Project SC-27, Bell Telephone Laboratories, Aug. 21, 1944. Div. 17-421-M1
3. *Jungle Acoustics*, Carl F. Eyring, OSRD 4699, OEMsr-1335, Service Project SC-105, Rutgers University, Feb. 15, 1945, Figure 1. Div. 17-411.2-M1
 - 3a. *Ibid.*, p. 4.
 - 3b. *Ibid.*, p. 38, Appendix C.
 - 3c. *Ibid.*, p. 7, Appendix A.
 - 3d. *Ibid.*, pp. 10-15.
 - 3e. *Ibid.*, p. 33.
 - 3f. *Ibid.*, p. 23.
 - 3g. *Ibid.*, p. 64.
 - 3h. *Ibid.*, pp. 36-61 and Figures 38-66.
4. *Recordings of Jungle Sounds*, Carl F. Eyring, OSRD 4704, OEMsr-1335, Service Project SC-105, Rutgers University, Feb. 17, 1945, p. 2 and Figure 1. Div. 17-411.2-M2
 - 4a. *Ibid.*, pp. 6-14.
 - 4b. *Ibid.* This report gives an annotated list of the species of birds, mammals, amphibians, and insects studied. Two edited records accompany this report; the original records are being preserved.
5. "The Absorption of Sound in Gases," Vern O. Knudsen, *The Journal of the Acoustical Society of America*, April 1935.
6. "The Absorption of Sound in Air, in Oxygen, and in Nitrogen, Effects of Humidity and Temperature." Vern O. Knudsen, *The Journal of the Acoustical Society of America*, October 1933.

7. *Sonic Deception, The Reproduction, Transmission and Reception of Deceptive Sounds*, OSRD 4094, OEMsr-908, BTL, Western Electric Co., Dec. 15, 1944.
8. "Auditory Patterns," Harvey Fletcher, *Review of Modern Physics*, Vol. 12, January 1940, pp. 47-65.
9. *Masking Experiments*, NDRC 6.1-sr30-1757, Service Projects NO-163 and NS-164, [Part] II, Report U-258, UCDWR, Sept. 15, 1944. Div. 6-560.21-M6

Chapter 9

1. *The Measurement of the Attenuation of Sound Waves of Finite Amplitude*, Harvey Fletcher, July 9, 1941.
2. *Attenuation of Intense Sound in the Atmosphere*, Vern O. Knudsen, R. W. Leonard, and others, OSRD 384, University of California, Dec. 31, 1941. Div. 17-431-M1
3. "Absorption of Sound in Gases," Vern O. Knudsen, *The Journal of the Acoustical Society of America*, Vol. 6, April 1935, p. 199.

Chapter 10

1. *Physiological Effects of Exposure to Certain Sounds* (Final Report), Hallowell Davis, Robert Galambos, Joseph E. Hawkins, Jr., Horace O. Parrack, Moses H. Lurie, and Jeannette C. Leighton, OSRD 889, OEMsr-119, Harvard University, July 31, 1942. See also *Effect of Sound on Man and Means for Producing Such Sound*, OSRD 1255, Nov. 9, 1942. Div. 17-435.21-M1
2. *Temporary Deafness Following Exposure to Loud Tones and Noise*, Hallowell Davis, Clifford T. Morgan, and others, OEMcmr-194, Harvard Medical School, Sept. 30, 1943. Div. 17-435.21-M2
3. *Injury to the Inner Ear Produced by Exposure to Loud Tones* (Supplementary Report), Joseph E. Hawkins, Jr., Moses H. Lurie, and Hallowell Davis, OEMcmr-194, Harvard Medical School, Dec. 31, 1943. Div. 17-435.21-M3

Chapter 11

1. *Effect and Production of Noise*, Robert M. Jones, Max Kupferberg, Joseph McCord, Earl F. Pound, Harry E. Geib, and Gerard S. Mercurio, OSRD Report, OEMsr-197, Service Projects OD-110, SC-47, and CE-39, Stevens Institute of Technology, Oct. 31, 1945, p. 48.

Chapter 12

1. *Effect and Production of Noise*, Robert M. Jones, Max Kupferberg, Joseph M. McCord, Earl F. Pound, Harry E. Geib, and Gerard S. Mercurio, OSRD Report, OEMsr-197, Service Projects OD-110, SC-47, and CE-39, Stevens Institute of Technology, Oct. 31, 1945, p. 108.
 - 1a. *Ibid.*, Figure 1, p. 60.
 - 1b. *Ibid.*, p. 127.
 - 1c. *Ibid.*, p. 86.
 - 1d. *Ibid.*, p. 187.
2. *Studies and Experimental Investigations in Connection with the Development of Sound Sources (Final Report)*, OSRD 1728, OEMsr-146, Army Project SC-4, Western Electric Co., June 15, 1943.

Chapter 13

1. *Sonic Deception, The Reproduction, Transmission and Perception of Deceptive Sounds*, OSRD 4094, OEMsr-908, BTL, Western Electric Co., Dec. 15, 1944.
2. *Radio Remote Control Device*, Earl F. Pound, OSRD Report, OEMsr-197, Service Project SC-47, Stevens Institute of Technology, Oct. 31, 1945.
3. *Water Heater, Acoustical and Timing System*, OSRD 4906, OEMsr-908, Service Project NR-104, BTL, Western Electric Co., Apr. 15, 1945.
4. *Water Heater*, D. F. Warner, OSRD 4907, OEMsr-1230, Service Project NR-104, General Electric Co., Apr. 16, 1945.

OSRD APPOINTEES

DIVISION 17

Chiefs

GEORGE R. HARRISON
PAUL E. KLOPSTEG

Deputy Chiefs

E. A. ECKHARDT
PAUL E. KLOPSTEG

Technical Aides

MILES J. MARTIN
FRANCIS L. YOST

CLARK GOODMAN
JOHN A. HORNBECK (WOC)

Members

O. S. DUFFENDACK
THEODORE DUNHAM, JR.
E. A. ECKHARDT
HARVEY FLETCHER

WILLIAM E. FORSYTHE
GEORGE R. HARRISON
HERBERT E. IVES
BRIAN O'BRIEN

MELVILLE I. STEIN

SECTION 17.1

Chief

E. A. ECKHARDT

Deputy Chief

HERBERT E. BRAGG

Spec. Asst. to Chief

JOHN A. HORNBECK

Technical Aide

HERBERT E. BRAGG

Members

CHARLES B. BAZZONI

J. M. CORK

SEMI J. BEGUN

SECTION 17.2

Chief

MELVILLE I. STEIN

Technical Aide

GEORGE E. BEGGS

Members

GIOACCHINO FAILLA

C. H. WILLIS

J. C. HUBBARD

SECTION 17.3

Chief

HARVEY FLETCHER

Spec. Asst. to Chief

WILLIAM S. GORTON

L. J. SIVIAN

Acting Chief

P. M. MORSE

Technical Aides

WILLIAM S. GORTON (WOC)

CLIFFORD MORGAN

*Members*DAVIS HALLOWELL
FLOYD A. FIRESTONE

E. C. WENTE

VERN O. KNUDSEN
STANLEY S. STEVENS

CONTRACT NUMBERS, CONTRACTORS, AND SUBJECT OF CONTRACTS

The contract information given below is for Division 17 work reported in (or related to) this volume. Contract information associated with Division 17 work reported in other volumes of the Division 17 Summary Technical Report is given in those volumes.

<i>Contract Number</i>	<i>Name and Address of Contractor</i>	<i>Subject</i>
NDCrc-97	Gulf Research and Development Company Pittsburgh, Pennsylvania	Studies and experimental investigations in connection with the development of a telemetric device for measurement of the rate of flow of fluids, etc., embodying the use of thermistors.
NDCrc-187	Carnegie Institution of Washington Washington, D. C.	Studies and experimental investigations in connection with (i) problems, such as those of magnetic compensation, and of optimum location, arising in conjunction with the use of magnetic compasses in tanks and other vehicles; (ii) similar problems which may arise in conjunction with the use of magnetic compasses in naval craft; (iii) continued consultation, tests, and redesign of vehicular odographs, marine odographs, and aircraft odographs, pedographs, and dead reckoning tracers generally; (iv) the development of a detonating mechanism for use with explosive charges, which mechanism is to be actuated by the magnetic field of a tank or other vehicle; (v) the study of the magnetic characteristics of vehicles, or naval craft, when necessary in connection with (i), (ii), (iii), and (iv) hereof; (vi) the development of a detector for magnetic masses, such detector to be free of any substantial external field of its own; and (vii) such other related problems as may arise from time to time.
OEMsr-12	The Trustees of the University of Pennsylvania Philadelphia, Pennsylvania	Studies and experimental investigations in connection with the improvement of instruments for measuring the oxygen saturation of blood in personnel operating military vehicles.
OEMsr-151	Carnegie Institution of Washington Washington, D. C.	Studies and experimental investigations in connection with (i) the magnetic field at various depths beneath and around tanks and motorized vehicles, (ii) the effects of deperming and degaussing on these magnetic fields, (iii) the most suitable location for degaussing coils on motorized vehicles from practical and theoretical points of view, (iv) the development of a mechanism operated by the magnetic fields of vehicles suitable for the discharge of land mines to test the effectiveness of protection, and (v) the development of a method of detecting land mines in ferro-magnetic cases, particularly such methods as may be employed in connection with the operation of motorized units.

CONTRACT NUMBERS, CONTRACTORS, AND SUBJECT OF CONTRACTS—(Continued)

<i>Contract Number</i>	<i>Name and Address of Contractor</i>	<i>Subject</i>
OEMsr-266	Gulf Research and Development Company Pittsburgh, Pennsylvania	Studies and experimental investigations in connection with the development of (i) improved methods of submarine mine control, (ii) a security device, (iii) an improved helium purity indicator for use in range-finders and lighter-than-air craft, (iv) a device for the determination of the quantity of fuel in the tanks of aircraft, (v) an indicator mine and associated devices and methods for determining the effectiveness of various explosive means of clearing minefields, and (vi) other instruments and devices of warfare when and as requested in writing by the Contracting Officer or an authorized representative.
OEMsr-267	The Trustees of the University of Pennsylvania Philadelphia, Pennsylvania	Studies and experimental investigations in connection with the development of an instrument for use in measuring the combustion efficiency in naval vessels.
OEMsr-340	Monroe Calculating Machine Company Orange, New Jersey	Studies and experimental investigations in connection with (i) the design, development, fabrication, and testing of one or more full-scale models of an odograph; (ii) and the design, development, fabrication, and testing of pilot models, suitable for production, of a remote reading compensated magnetic compass to provide direction indications for the odograph.
OEMsr-426	International Business Machines Corporation Endicott, New York	Studies and experimental investigations in connection with (i) the design, development, fabrication, and testing of one or more full-scale models of an odograph, (ii) the redesign, construction, and testing of twelve (12) full-scale models of an aircraft odograph, and (iii) the redesign and manufacture of pilot units of said redesigned airborne odographs in such numbers as the Contractor and the Scientific Officer estimate can be prepared within the maximum amount of contract funds.
OEMsr-544	Central Scientific Company Chicago, Illinois	Studies and experimental investigations in connection with the development of a production model of the flight oximeter developed under Contract No. OEMsr-12.
OEMsr-1121	General Motors Corporation, Research Laboratories Division Detroit, Michigan	Studies and experimental investigations in connection with (i) the development of a remote indicating inductor compass, and (ii) means for demagnetizing tanks and other vehicles, and the effects thereof on compasses.

CONTRACT NUMBERS, CONTRACTORS, AND SUBJECT OF CONTRACTS—(Continued)

<i>Contract Number</i>	<i>Name and Address of Contractor</i>	<i>Subject</i>
OEMsr-1256	Radio Corporation of America, RCA Victor Division Camden, New Jersey	Studies and experimental investigations in connection with the development of radio control apparatus for the synchronous firing of one or more photoflash bombs in conjunction with airborne camera equipment which meets the majority of the military specifications as outlined by the representatives of the Ordnance Department; delivery and field testing of one hundred twenty-five (125) bomb receiving units, type T-58.
OEMsr-1148	Hughes Aircraft Company, a Division of the Hughes Tool Company, a Corporation Culver City, California	Studies and experimental investigations in connection with the (i) engineering of a radio chronometer comparator for time control of astronomic survey, including modification or redesign of radio receiver equipment to be used in conjunction with the chronometer comparator, and (ii) construction of three complete field test systems comprised of comparator circuits, radio receivers and antennae, all equipment to be small, rugged, suitable for use under extremely adverse conditions, and easily transportable.

SERVICE PROJECT NUMBERS

The projects listed below were transmitted to the Executive Secretary, NDRC, from the War or Navy Department through either the War Department Liaison Officer for NDRC or the Office of Research and Inventions (formerly the Coordinator of Research and Development), Navy Department.

<i>Service Project Number</i>	<i>Subject</i>
<i>Army Projects</i>	
AC-48	Airborne odograph.
AC-80	The development of a simple light-weight and accurate flow meter for use as a flight and cruising control instrument in aircraft.
AC-110	Engineering of radio chronometer comparator for time control of astronomic survey.
CE-18	Development of an odograph for military road reconnaissance.
CE-28	Vehicular remote-indicating compass.
CE-28 Ext.	Compasses for armored vehicles.
OD-17	Determination of a suitable compass or direction indicating system for armored combat vehicles, including provision for repeater instruments for the driver, commander, and all gunners.
OD-141	Radio means for synchronization of aerial camera shutter and photoflash bombs.
<i>Navy Projects</i>	
NA-153	Simplified airborne odograph.
NA-154	Fuel quantity gauge.
NS-96	Development of a boiler flue gas indicator.
NS-124	Dead reckoning tracer for use on surface vessels.
NS-170	Design of magnetic compass equipment.

INDEX

The subject indexes of all STR volumes are combined in a master index printed in a separate volume. For access to the index volume consult the Army or Navy Agency listed on the reverse of the half-title page.

- Acoustic bomb, 113-116
 evaluation, 115
 intensity and rate of attenuation, 114-115
 methods of combining explosions, 113-114
- Acoustic fuel-measuring device, 75, 76
- Acoustics of jungle
 see Jungle acoustics
- Aerial mapping instrument, 73-74
- Aerial photography
 see Photoflash bomb photography
- AES heater (Army Experimental Station loudspeaking system), 140-146
 dimensions and weights, 143
 loudspeakers, 144-146
 magnetic recorder-reproducer, 143
 microphones and amplifiers, 143-144
 power supply, 146
- Air mileage devices, 24-26
 British unit, 25
 comparative summary of air-speed devices, 25-26
 impeller log, 25
 Pioneer pump unit, 25
 Schwien true airspeed meter, 25
- Airborne compass, 23-24
- Airborne integrator, 33-39
 air drift compensator, 34, 37
 components, 33-34
 plotting table, 37-38
- Aircraft fuel gauges, 75-79
 acoustic volume-measuring device, 75, 76
 capacity type, 75, 78-79
 electric frequency meter and tachometer, 75-76
 hot-wire gauge, 75-78
 types of fuel, 78
- Airdrift compensator for integrator, 34, 37
- Airspeed indicators, 24-26
 British unit, 25
 comparative summary, 25-26
 impeller log, 25
 Pioneer pump unit, 25
 Schwien meter, 25
- Anoxia measuring instruments, 68-72
 evaluation, 72
 flight research oximeter, 68, 71
 oxygen want indicators, 68-71
- AO-3, airborne odograph, 39
- Army Experimental Station
 junior heater, 140-146
 sound transmission and reception, 131-138
- Attack plotter, odograph equipment, 56
- Azimuth indicator for integrator, 32
- Bell Telephone Laboratories
 magnetic recorder, 143
 siren for sonic deception, 128
- Boilers, combustion efficiency indicators
 see Combustion efficiency indicators, boilers
- Bomb, acoustic, 113-116
 evaluation, 115
 intensity and rate of attenuation, 114-115
 methods of combining explosions, 113-114
- Bomb receiver, photoflash bomb photography, 61, 64-65
- Breeze flowmeter, 75
- British
 air mileage unit, 25
 fuel gauges, 78
 Weymouth fuel gauge, 79
- Brush Development Company, 143
- BTL (Bell Telephone Laboratories)
 siren, sound masker, 128
- Canary motor sound simulator, 123-126
 acoustic performance, 125-126
 as masking device, 128
 operation, 123-125
- Carbon dioxide recorders for combustion efficiency measurement, 80-83
 maintenance, 82-83
 reliability, 82
 types, 80, 82-83
- Carnegie Institution of Washington, 4
- Central Scientific Company, 71
- "Charlie" (sound simulating device), 117
- Chronometer comparator, radio, 73-74
- CMR (Committee on Medical Research), 110
- Coleman ear unit, oximeter, 71
- Combustion efficiency indicator, boilers, 80-84
 carbon dioxide recorders, 81-83
 elimination of smoke, 80
 factors affecting combustion efficiency, 81
 flame brightness, 84
 military requirements, 80
 steam flow-oil flow ratio, 84
- Committee on Medical Research, 110
- Comparator, radio chronometer, 73-74
- Compass, airborne, 23-24
- Compass, magnesyn, 56
- Compass, vehicular odograph, 6-23
 comparison of compasses, 20
 compass followers, 7
 demagnetization of military vehicles, 10-13
 DTM compass, 13-17
 error compensation, 7-13
 gyroscopic compass, 6-7
 inductor compass, 17-23
 magnetic compass, 7-17
 reduction of vibration effects, 17
- Compass error compensation, 7-13
 DTM compass, 14-17
 heeling and pitching errors, 9
 quadrantal error, 8-9
 semicircular error, 8
 subpermanent magnetization, 9-10
- Compass for landing craft, 56
- Course plotting instrument
 see Odograph equipment
- Deafness caused by noise, 110-112
 experiments with animals, 111-112
 hearing loss produced in humans, 110-111
- Department of Terrestrial Magnetism
 compass, 13-17
 experimental integrator, 28-30
- Diffraction in ultrasonic signaling, 90
- Diplacsis (pitch perception), 110, 111

- Disk drive integrator
 air drift compensator, 34, 37
 components, 33-34
 plotting table, 37-38
- Distance measuring instruments
 air mileage devices, 24-26
 sea logs, 26-27
- DTM compass (Department of Terrestrial Magnetism), 13-17
 error compensating system, 14-17
 servomechanism, 13-14
- DTM experimental integrator (Department of Terrestrial Magnetism), 28-30
 functions, 29-30
 interpolation by hunting, 29
 variable coupling element, 28-29
 variable map scale, 29-30
- Dynamotors for loudspeaking system, 155
- Electrical Products Research, Inc., 135
- Eraser, magnetic, 11-13
 applications and tests, 11-13
 theory of operation, 11
- Explosions, effect of combining charges, 113-116
 evaluation, 115
 intensity and rate of attenuation, 114-115
 methods of combining explosions, 113-114
- Explosive sound characteristics, 117-119
 effect of terrain, 119
 oscillograms, 117, 120-121
- Flash bomb photography
see Photoflash bomb photography
- Flight research oximeter, 68, 71
- Flowmeter, Breeze, 75
- Fluxgate compass, 23-24
- Fort Hancock, N. J., 131
- Fuel gauges, aircraft, 75-79
 acoustic volume-measuring device, 75, 76
 capacity type gauge, 75, 78-79
 electric frequency meter, 75-76
 hot-wire gauge, 75-78
 types of fuel, 78
- Fuze, photoflash
see Photoflash bomb photography
- Gauges, aircraft fuel, 75-79
 acoustic volume-measuring device, 75, 76
 capacity type, 78-79
- electric frequency meter and tachometer, 75-76
 hot-wire gauge, 76-78
 types of fuel, 78
- General Electric Company, 56
- GM (General Motors) Research Laboratory
 inductor compass, 17-23
 magnetic eraser, 10-13
- Gulf Research and Development Company, 78
- Gun simulators, 120-123
 large field pieces, 123
 machine gun, 122
 mortar fire, 123
 rifle fire, 122
 single shots, 120-121
- Gyroscopic compass, 6-7, 23-24
- Hallcrafters S-39 radio receiver, 73
- Harvard University, 110
- Hays carbon dioxide recorder, 82
- Hearing loss produced by noise, 110-112
 experiments with animals, 111-112
 in humans, 110-111
- Heaters for sound deception, 138-170
 experimental equipment, 138
 junior heater, 140-146
 remote control device, 146-148
 S2M heater, 138-140
 water heater, 148-170
- Hot-wire fuel gauge, 75-78
 electric circuit, 77
- HR (Hays carbon dioxide recorder), 82
- Hughes Aircraft Company, 73
- IBM Company (International Business Machines), 30-38
- IBM disk drive integrator, 33-39
 air drift compensator, 34, 37
 components, 33-34
 plotting table, 37-38
- IBM ratchet drive integrator, 30-33
 azimuth indicator, 32
 magnetic deviation correction, 32
 scale changing, 32-33
 variable coupling, 30-32
- Impeller log (air mileage device), 24
- Inductor compass, 17-23
 comparative tests with standard compasses, 40
 mu-metal core, 17
 performance tests, 20-23
- principles of operation, 17-18
 servomechanism, 18-20
- Integrators, odograph, 27-39
 DTM experimental integrator, 28-30
 IBM disk drive airborne integrator, 33-39
 IBM ratchet drive integrator, 30-33
 requirements, 5, 27-28
 scotch yoke, 27-28
- International Business Machines Corporation, 30-38
- Intervalometer for photoflash bomb photography, 59, 62
- Johns Hopkins University, 77
- Jungle acoustics, 92-105
 ambient sounds, 96-99
 definition of terms, 93-94
 intensity level available for transmission loss, 100, 102
 judging sound direction, 98-99
 masking of ambient noise, 99-100
 micrometeorology in tropics, 102-105
 research apparatus, 92-93
 tactical problems, 99-102
 tests on various terrains, 94-96
 transmission loss measurements, 92-96
- Junior heater (loudspeaking system), 140-146
 dimensions and weights, 143
 loudspeakers, 144-146
 magnetic recorder-reproducer, 143
 microphones and amplifiers, 143-144
 power supply, 146
- Knudsen, terrain loss coefficients, 94-95
- KS-12009 magnetic recorder, 143
- Landing craft compasses, 56
- LNR (Leeds and Northrup carbon dioxide recorder), 82-83
- Logs for odograph, 26-27
 impeller log, 25
- Loudspeaking systems, sonic deception, 138-170
 experimental equipment, 138
 junior heater, 140-146
 remote control device, 146-148
 S2M heater, 138-140
 water heater, 148-170
- M-1 standard compass, 40

- Machine gun simulators, 122
- Magnesyn compass, 56
- Magnetic airborne detector, use of odograph, 49
- Magnetic compasses, 7-17
demagnetization of vehicles, 10-13
DTM compass, 13-17
sources of error, 8-10, 41-42
- Magnetic eraser, 10-13
applications and tests, 11-13
theory of operation, 11
- Magnetic fields of vehicles, 10-13
magnetic eraser, 11-13
measuring instrument, 10
- Magnetic recorder-reproducer
AES loudspeaking system, 143
S2M heater, 139
water heater, 152, 154, 160
- Magnetization of compasses, sub-permanent, 9-10
- Magnetometer, remote-indicating, 10
- Mapping instrument, aerial, 73-74
- Masking of sounds for enemy deception, 126-130, 136-138
BTL siren, 128
canary motor, 129
jungle sounds, 99-100
minimum masking noise, 136-137
principles of masking, 127
required intensity for deception, 136-137
sounds of vehicles, 126-130
- Meteorological equipment, ultra-sonic signaling, 88
- Meteorological study of jungle, 102-105
apparatus and definitions, 102-104
equipment, 93
humidity measurements, 105
temperature data, 103-104
terrain loss coefficients, 95-96
wind velocity measurements, 104
- Mileage measuring instruments, 24-27
air mileage, 24-26
sea logs, 26-27
- Monroc Calculating Machine Company
DTM compass, 13-17
DTM experimental integrator, 13-17
- Mortar fire simulation, 123
- Motor sound simulation, 123-126
- Multiphase intervalometer, photo-flash bomb photography, 59, 62-63
- Naval Boiler and Turbine Laboratory, 81
- Naval combustion efficiency indicator
see Combustion efficiency indicator, boilers
- Naval Research Laboratory, 81
- Night photography of aerial bombs, 58
- Noise, physiological effects, 110-112
animals, 111-112
humans, 110-111
- Noise in jungle
ambient sounds, 96-99
masking of ambient noise, 99-100
- Noise masking, sonic deception
see Masking of sounds for enemy deception
- Odograph equipment, 5-57
airborne compass, 23-24
application to magnetic airborne detector, 49
attack plotter for ships, 56
integrators, 27-39
mileage and speed devices, 24-27
pedograph, 5, 52-55
portable, 52-56
power supply, 56
required elements, 5-6
step-writer, 5, 52-55
vehicular compass, 6-23
- Odograph test installations, 5, 39-49
aircraft, 39, 46-52
amphibious truck, 44-46
half-track, 43
jeep, 40-41
snow vehicles, 43
tanks, 41-43
- Odometers, 24-27
air mileage, 24-26
sea logs, 26-27
- Orsat apparatus, 82
- "Oscar" (dummy paratrooper), 117
- Oximeters, 68-72
evaluation, 72
flight research oximeter, 68, 71
oxygen want indicators, 68-71
- Oxygen saturation measurement
see Oximeters
- Oxygen want indicator, 68-71
ear unit, 69
pointer indicator, 69-70
signal light indicators, 70-71
- Parabolic reflectors, ultrasonic signaling, 88
- Pedograph, 5, 52-55
- Pennsylvania State College, 87
- Photoflash bomb photography, 58-67
bomb receiver, 61, 64-65
characteristics of apparatus, 65-67
field tests, 61-62
general description, 59-62
military requirements, 58-59
multiphase intervalometer, 59, 62-63
night photography, 58
radio transmitter, 61, 64
synchronizer, 60, 63-64
- Physiological effects of noise, 110-112
animals, 111-112
humans, 110-111
- Pine Camp, New York, 131
- Pioneer Instrument Company
gyrostabilized fluxgate compass, 23
pump unit, 25
- Pitch perception, 110, 111
- Pitot tube for airspeed indicator, 25
- Pointer indicator, oxygen saturation, 69-70
- Primacord as a gun sound simulant, 121
- Psychological factors in sonic deception, 170
- Public address systems, sonic deception, 138-170
experimental equipment, 138
junior heater, 140-146
remote control device, 146-148
S2M heater, 138-140
water heater, 148-170
- RA 277 sound frequency analyzer, 135
- Radio chronometer comparator, 73-74
- Radio transmitter, photoflash bomb photography, 61, 64
- Ranarex carbon dioxide recorder, 80, 82-83
evaluation, 83
suggested improvements, 83
- Ratchet drive integrator, 30-33
azimuth indicator, 32
magnetic deviation correction, 32
scale changing, 32
variable coupling, 30-32
- RC models for heaters (remote control), 146-148
models 2 and 3, 147-148
requirements, 146-147

- Receivers
 photoflash bomb photography, 60, 67
 ultrasonic signaling, 87
- Recorders
 carbon dioxide, 81-83
 magnetic, 139-143, 152-154, 160
- Reflectors for ultrasonic signaling, 87
- Refraction of sound rays, 133-134
- Rifle simulators, 122
- Royal Aircraft Establishment, 78
- Rozek hot-wire gauge, 77
- RR (Ranarex carbon dioxide recorder), 80, 82-83
- Rutgers University, 92
- S2M heater (loudspeaking system), 138-140
 dimensions and weights, 138
 performance, 140
- S-39 radio receiver, 73
- Schwein true airspeed meter, 25
- Sea logs, 26-27
- Servomechanisms for compasses
 DTM compass, 13-14
 inductor compass, 18-20
- Signal light indicators, oxygen saturation, 70-71
- Simulation of sound
see Sound simulation
- Sonic deception, 117-170
 masking noise and reception, 136-138
 masking sounds of military vehicles, 126-130
 mobile loudspeaking systems, 138-170
 psychological factors, 170
 sound simulation, 117-126
 sound transmission and reception studies, 131-138
 tactical consideration, 170
 techniques of sound recording, 131-132
- Sound absorption, 106, 134
- Sound apparatus, jungle acoustics, 93
- Sound attenuation, 106-108
- Sound characteristics, explosive, 117-119
 effect of terrain, 119
 oscillograms, 117, 120-121
- Sound frequency analyzer, 135
- Sound masking, sonic deception
see Masking of sounds for enemy deception
- Sound propagation characteristics, 133-135
 loss of energy, 133
- refraction of sound rays, 133-134
- Sound ranging on simulated sounds, 121-122
- Sound recording techniques, 131-132
- Sound simulation, 117-126
 character of explosive sounds, 117-119
 detection by sound-ranging equipment, 121-122
 listening tests, 121
 machine guns, 122
 motor sounds, 123-126
 rifle fire, 122
- Sound transmission, 87-109, 131-138
 jungle acoustics, 92-105
 meteorological conditions, 132-133
 propagation characteristics, 133-135
 sound source, 131-132
 ultrasonic signaling, 87-91
- Sound transmission loss, 106-109, 133-135
 absorption by vegetation, 134
 absorption in air, 134
 absorption of waves of finite amplitudes, 106
 attenuation of waves of small amplitudes, 106-108
 influence of terrain, 108-109
 temperature and wind refraction, 109
 temperature gradient, 133
 wind velocity gradient, 133-134
- Speed measuring devices, 24-27
 air mileage instruments, 24-26
 sea logs, 26-27
- Stavrovkov (log pickup unit), 45
- Step-writer, 5, 52-55
- Stevens Institute Canary, 129
- Subpermanent magnetization in compasses, 9-10
- Supersonic signaling
see Ultrasonic signaling
- Synchronizer, photoflash bomb photography, 60, 63-64
- T-4 mechanical arming device, photoflash bomb, 67
- T-58 photoflash fuze
see Photoflash bomb photography
- Tanks, effect on magnetic compasses, 41-42
- Temperature fluctuation, definition, 102
- Temperature gradient, definition, 94, 132
- Temperature profiles, definition, 94
- Temperature refraction, 109
- Terrain loss, definition, 93-94
- Terrain loss, definition, 93-94
- Temperature compass, 17-23
 comparative tests with standard compasses, 40
 mu-metal core, 17
 performance tests, 20-23
 principles of operation, 17-18
 servomechanism, 18-20
- Transmission loss in jungle acoustics, 93-96
see also Sound transmission loss
 definition of terms, 93-94
 intensity level, 100, 102
 research apparatus, 93
 tests on various terrains, 94-96
- Transmitter, photoflash bomb photography, 61, 64
- Ultrasonic signaling, 87-91
 conclusions, 90-91
 diffraction, 90
 meteorological equipment, 88
 optimum weather conditions, 90
 parabolic reflectors, 87
 range measurements, 88-89
 receivers, 87
 research equipment, 87-88
 transmission measurements, 88-90
- University of Pennsylvania, 81
- Vehicles, magnetic fields, 10-13
 magnetic eraser, 11-13
 measuring instrument, 10
- Vehicles, sound masking, 126-130
- BTL siren, 128
 canary, 128
 evaluation of deceptive instruments, 129-130
 intensity of group of vehicles, 127
 principles of masking, 127
- Vehicular odograph compass
see Compass, vehicular odograph
- Water heater (loudspeaking system), 148-170
 acoustic and timing system, 149-162
 amplifier, 154
 anchoring mechanism, 165-166
 attenuator, 158, 162
 dynamotors, 155
 electric circuits, 150-152
 elevator mechanism, 166-167
 firing circuit, 168
 loudspeaker, 156-158

operation, 168-170
orientation mechanism, 167-168
performance, 148
power supply, 163
propulsion equipment, 163
recorder, 160

reproducer, 152, 154
timing mechanism, 152-153, 158-160
Waymouth fuel gauge, 79
Wind gustiness, definition, 103
Wind refraction, 109

Wind velocity gradient, definition, 94, 132
Wind velocity variability, definition, 102
XA-2 Zenith camera, 73



TITLE: Compasses, Odographs, Combat Acoustics, and Sonic Deception Vol. 2

AUTHOR(S): Nettleton, L.L.; Beggs, George E.; Yost, F. L.; and others
ORIGINATING AGENCY: Office of Scientific Research and Development, NDRC, Div 17
PUBLISHED BY: (Same)

ATI- 30810

REVISION
(None)

ORIG. AGENCY NO.
(None)

PUBLISHING AGENCY NO.
(None) (OVER)

U

DATE	DOC. CLASS.	COUNTRY	LANGUAGE	PAGES	ILLUSTRATIONS
1946	Conf'd 1	U.S.	Eng.	199	photos, tables, diagr, graphs

ABSTRACT:

A description is given of the development of the following: compasses for use in heavily armored vehicles, T-58 photoflash fuse for use with a falling photoflash bomb, oximeters, a radio chronometer comparator, and fuel quantity gauges. Other discussions concern: ultrasonic signaling, jungle acoustics measurements, attenuation of sound in the atmosphere, injurious effects of exposure to loud tones and noises, high-intensity sound produced by chain explosions, and a mobile loudspeaking system for deception and decoy.

UNCLASSIFIED

NOTE: Previously cataloged as KK 13897 NAD 15678

DISTRIBUTION: Copies of this report obtainable from Air Documents Division; Attn: MCIDXD

DIVISION: Aeronautical, General (47) 32
SECTION: Yearbooks (4)

SUBJECT HEADINGS: Research - Progress reports (81658.917);
Sonar (87473); Instruments, Navigation (52220); Acoustics
(0000)

ATI SHEET NO.: C-47-4-2

Air Documents Division, Intelligence Department
Air Materiel Command

AIR TECHNICAL INDEX

Wright-Patterson Air Force Base
Dayton, Ohio

NAD 15678

KK 13897

U

Auth: Sec of Def memo, 2 Aug 60
(PR No. 136)