

UNCLASSIFIED

AD NUMBER

AD114884

CLASSIFICATION CHANGES

TO: unclassified

FROM: confidential

LIMITATION CHANGES

TO:
Approved for public release, distribution unlimited

FROM:
Controlling DoD Organization. Bureau of Aeronautics [Navy], Washington, DC

AUTHORITY

BUAER ltr, 31 Aug 1968; BUAER ltr, 31 Aug 1968

THIS PAGE IS UNCLASSIFIED

AD No. 114884
ASIA FILE COPY

CONFIDENTIAL

21269

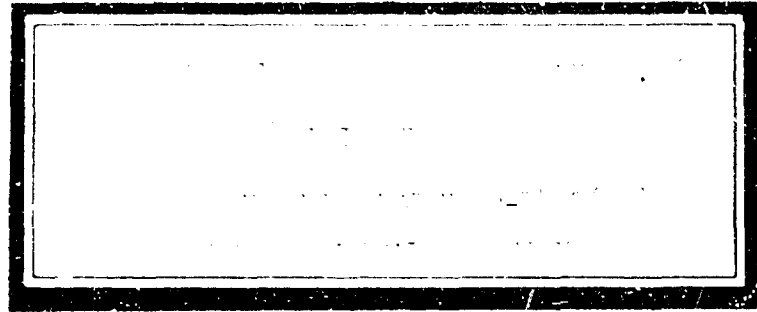

FC

This document has been prepared in accordance with
the provisions of the Freedom of Information Act, 5 U.S.C. 552
and is hereby released to the public.
10/27/76
OFFICE OF THE ATTORNEY GENERAL (129)

CONFIDENTIAL

5647

57133

C O N F I D E N T I A L

FINAL REPORT

COVERING CONTRACT NOnr 1487(00)

ENGINEERING CONSULTING SERVICES PERFORMED BY
BECCO CHEMICAL DIVISION OF FOOD MACHINERY AND
CHEMICAL CORPORATION IN CONJUNCTION WITH ALTON
PROJECT DEVELOPMENT AT U.S. NAVAL ENGINEERING
EXPERIMENT STATION, ANNAPOLIS, MARYLAND

JUNE 1954 - JUNE 1956

Prepared by:

Willard A. Sanscrainte - Senior Development Engineer
James C. McCormick - Group Leader
Ralph Bloom, Jr. - Project Supervisor

Approved by:

Noah S. Davis, Jr., Manager

Special Projects

"This document contains information affecting the national defense of the United States within the meaning of the Espionage Laws, Title 18, U.S.C., Secs. 793 and 794. Its transmission or the revelation of its contents in any manner to an unauthorized person is prohibited by law.

Reproduction of this matter in any form by other than Naval activities is not authorized except by specific approval of the Secretary of the Navy.

31 August 1956

BECCO CHEMICAL DIVISION
FOOD MACHINERY AND CHEMICAL CORPORATION
STATION B BUFFALO 7, N. Y.

C O N F I D E N T I A L

COPY NO. 6

C O N F I D E N T I A L

FINAL REPORT

COVERING CONTRACT NO. 1487(00)

ENGINEERING CONSULTING SERVICES PERFORMED BY
BECCO CHEMICAL DIVISION OF FOOD MACHINERY AND
CHEMICAL CORPORATION IN CONJUNCTION WITH ALTON
PROJECT DEVELOPMENT AT U.S. NAVAL ENGINEERING
EXPERIMENT STATION, ANNAPOLIS, MARYLAND

JUNE 1954 - JUNE 1956

Prepared by:

Willard A. Sanscrainte - Senior Development Engineer
James C. McCormick - Group Leader
Ralph Bloom, Jr. - Project Supervisor

Approved by:

Noah S. Davis, Jr., Manager

Special Projects

Reproduction of this matter in any form by other than Naval activities is not authorized except by specific approval of the Secretary of the Navy.

"This document contains information affecting the national defense of the United States within the meaning of the Espionage Laws, Title 18, U.S.C., Sections 793 and 794. Its transmission or the revelation of its contents in any manner to an unauthorized person is prohibited by law."

31 August 1956

BECCO CHEMICAL DIVISION
FOOD MACHINERY AND CHEMICAL CORPORATION
STATION B BUFFALO 7, N. Y.

C O N F I D E N T I A L

COPY NO. 2

C O N F I D E N T I A L

DISTRIBUTION LIST

Nos. 1-8 Chief of Naval Research
Department of the Navy
Washington 25, D.C.
Attention: Code 429

No. 9 Chief, Bureau of Ships
Department of the Navy
Washington 25, D.C.
Attention: Code 320

No. 10 Chief, Bureau of Ships
Department of the Navy
Washington 25, D.C.
Attention: Code 525

No. 11 Chief, Bureau of Ships
Department of the Navy
Washington 25, D.C.
Attention: Code 551

Nos. 12-13 Commanding Officer
Office of Naval Research
Branch Office
346 Broadway
New York 13, New York

Nos. 14-15 Director
U. S. Naval Experiment Station
Annapolis, Maryland

No. 16 Chief, Bureau of Ordnance
Department of the Navy
Washington 25, D.C.
Attention: Re6

No. 17 Chief, Bureau of Ordnance
Department of the Navy
Washington 25, D.C.
Attention: Ad3

Nos. 18-19 Commanding Officer
U. S. Naval Underwater Ordnance Station
Newport, Rhode Island

Nos. 20-21 Commander
U. S. Naval Ordnance Test Station, Inyokern
China Lake, California
Attention: Technical Library

C O N F I D E N T I A L

C O N F I D E N T I A L

D I S T R I B U T I O N L I S T

No. 22 Commanding Officer & Director
 U. S. Naval Boiler and Turbine Laboratory
 Naval Base
 Philadelphia, Pennsylvania

No. 23 Aerojet-General Corporation
 Azusa, California
 Via: Commanding Officer
 Office of Naval Research
 Branch Office
 1030 East Green Street
 Pasadena 1, California

C O N F I D E N T I A L

C O N F I D E N T I A L

TABLE OF CONTENTS

| | <u>Page No.</u> |
|--|-----------------|
| Abstract | |
| I. . Introduction | 1 |
| II.. Alton Chamber Analysis and Modification Recommended | 3 |
| III. Test System At EES | 6 |
| IV.. Preliminary Testing | 9 |
| V. . Results of Test Runs and Conferences Held at EES During the Test Program | |
| a. Conferences and Results of Test Runs #6-71-12B | 13 |
| b. Results of Test Runs 71 and 72-12B | 24 |
| VI.. Summary Discussion of Combustion Chamber Modifications | 25 |
| VII. Results of Combustion Tests Carried out at Becco | 27 |
| VIII. Conclusions and Recommendations | 31 |

Tables

| | |
|--|----|
| I. Test Data Run #68 Modified CC-12 Combustion Chamber | 35 |
| II. Instrumentation at EES | 36 |
| III. Run 5-12B Summary Data | 38 |
| IV. Data Before and After Temperature Changes | 39 |
| V. Data Summary Runs 71 and 72-12B | 40 |
| VI. Various System Pressures Additional Data - Run 72-12B | 42 |
| VII. Test Results - 90% H ₂ O ₂ Decomposition Diesel Fuel Combustion at Becco | 43 |

Plates

| | |
|--|----|
| 1. Fuel Spray Pattern Used in Runs Nos. 1-6 at Becco - Donut Baffle Attached | 44 |
| 2. Fuel Spray Pattern #70-80° Monarch Hollow Cone Used in Runs Nos. 7 and 8 at Becc | 45 |
| 3. Fuel Spray Pattern #28-60° Monarch Hollow Cone Run No. 9 Becco Tests | 46 |

C O N F I D E N T I A L

C O N F I D E N T I A L

TABLE OF CONTENTS (contd)

| | <u>Page No.</u> |
|--|-----------------|
| <u>Plates</u> | |
| 4. Fuel Spray Pattern Solid Cone Run No. 10 Spraying Systems No. 5 | 47 |
| 5. Fuel Spray Pattern Spraying Systems #3.5 Solid Cone Run No. 11 | 48 |
| 6. Nitrogen and Aluminum Powder Flow Pattern Through Plastic Mockup with Ring Baffle Installed | 49 |

Figures

1. Allis Chalmers 10" x 16" Combustion Chamber
2. Modified Liner in Allis Chalmers 10" x 16" Combustion Chamber (CC-12 Chamber)
3. Modified Fuel Injector Used in Hull Mockup Test Runs Nos. 69-80
4. Modified Liner in CC-12 Combustion Chamber Used in Test Runs Nos. 76-80
5. Engineering Experiment Station Designed CC-13 Combustion Chamber Used in Test Runs Nos. 81-84
6. Modified Head Section for the Experimental Combustion Chamber CC-12
7. Details of the Modified Head for the CC-12 Combustion Chamber used in runs nos. 1-72-12B
8. Schematic Diagram of the Flow System at the Engineering Experiment Station. Used for the Chamber Tests
9. Safety Trip-Out System Incorporated in the Combustion Chamber Flow System at the Engineering Experiment Station
10. Plan View of CC-12 Combustion Chamber as Modified for Test Runs Nos. 1-5-12B.
11. CC-12 Combustion Chamber Showing Thermocouple Location
12. Fuel Injector as Modified for Test Run #8-12B

C O N F I D E N T I A L

C O N F I D E N T I A L

TABLE OF CONTENTS (contd.)

Figures

13. Fuel Injector Incorporating a Sleeve Deflector Used in Runs #14-17-12B, 19-22-12B Model 12BF
14. Baffle Evaluated as a Control for the Oxidant Gas Stream Used in Test Runs #23 - 24-12B
15. Baffle Evaluated as a control for the Oxidant Gas Stream Model #12B2B Used in Test Run #25-12B
16. Baffle Evaluated as a Control for the Oxidant Gas Stream and as a Possible Flame Holder Model 12B2C Used in Test Run #26-12B
17. Becco Designed "Donut" Baffle as Mounted on the Fuel Nozzle Model #12BE Used in Test Runs #27 and 29-12B
18. The Donut Baffle Incorporating Various Modifications Used in Test Runs #30-45-12B
19. Arde Associates Designed Dual Swirl Turbulence Inducer Baffle Used in Test Run #46-12B
20. Donut Baffle as Redesigned and Built with 1/4" Throat to Baffle Clearance Used in Test Run #48-53-12B
21. Donut Baffle as Modified for Test Runs #54-56, 58-66-12B
22. Modified CC-12 Combustion Chamber Incorporating a Water Spray Ring at the Uncooled Liner Packing Section
23. Becco Designed Umbrella Type Single Diluent Water Nozzle as Mounted in the CC-12 Chamber for Test Runs #63-64-12B.
24. Donut Baffle as Modified by the Addition of Slots Through the Baffle Spacer Ring Used in Test Runs #67-12B, 71 and 72-12B.
25. Donut Baffle as Modified and Mounted for Test Runs #68 and 69-12B
26. Combustion Chamber Configuration Used in Test at Becco 2-1/2" ID x 4-5" long combustion zone
27. Flow System Used in Combustion Chamber Tests at Becco
28. Becco Combustion Tests Flat Flame Holder Through Restricted Entry head Insert
29. Becco Combustion Tests Conical Flame Holder Through Restricted Entry Head Insert

C O N F I D E N T I A L

C O N F I D E N T I A L

TABLE OF CONTENTS (contd.)

Figures

30. Becco Combustion Tests Flame Holder, Straight Through Head
31. Reverse Flow Test Assembly Used in Tests at Becco
32. Apparatus Used to Study the Flow Characteristics in a Transparent Model Combustion Chamber Using High Speed Photograph

C O N F I D E N T I A L

C O N F I D E N T I A L

ABSTRACT

A 10,000 shaft horsepower submarine propulsion system utilizing a closed, steam generation cycle with turbine - reduction gear drive was assembled and operated at the U.S.N. Engineering Experiment Station, Annapolis, Maryland, from 1946 to 1954. The system was designated the Alton cycle. The propulsion unit utilized the combustion of diesel fuel and decomposed 90% hydrogen peroxide. Exhaust gas from the water cooled combustion chamber was desuperheated to provide turbine steam inlet conditions of 750 psig and 1300°F at full power. The cooling and desuperheat water supply was furnished by the turbine condenser. The Alton cycle represented an improved version of an H₂O₂-diesel fuel propulsion system rated at 2500 shaft horsepower developed by Germany during World War II.

When the Alton project was terminated on 1 March 1954, the only major component of the system requiring further development was the combustion chamber. The first Alton combustion chamber failed because of burning of the water cooled chamber liner which was in contact with the intense combustion. Modifications of the liner, fuel nozzle, and liner cooling water system were unsuccessful in preventing liner burnout particularly at extended full-power operation.

Becco Chemical Division of Food Machinery and Chemical Corporation was awarded a contract on 1 May 1954 to analyze the failure of the Alton cycle combustion chamber and to recommend steps to prevent burnout. On 1 July 1954, a research project commenced at the Engineering Experiment Station to develop a reliable chamber for the Alton system. The development program was sponsored jointly by the Bureau of Ships Research and Development Section and the Office of Naval Research. Becco's contract was amended to provide engineering consulting services during the duration of the program.

C O N F I D E N T I A L

C O N F I D E N T I A L

The actual test work under the new program was started in January 1955, utilizing a combustion chamber liner design and liner instrumentation previously proposed by Becco. Fuel nozzle, decomposition gas inlet turbulence devices, and combustion gas cooling water spray modifications were made with varying degrees of success during 71 development test runs. A final design evolved which gave successful operation for 2-1/2 hours of continuous running at near full power in the final run, #72-12B. It is Becco's opinion that the chamber configuration employed in run 72-12B could successfully meet the requirement of full power operation for 10 hours. The program was terminated on 31 June 1956.

A brief decomposed H_2O_2 - diesel fuel combustion study was conducted at Becco in May and June of 1956 with a small combustion chamber. The program evaluated 8 fuel injection or liner modifications that had not been evaluated during tests of the Alton system.

On the basis of the test program at EES and Becco, recommendations are made for further improvement of the simplicity of design and reliability of the combustion chamber configuration which operated successfully in run 72-12B. One of the recommendations is based on an analytical description of the Alton chamber combustion reaction prepared by Becco consultants. The development of the analytical description and the close degree of correlation between the analytical predictions and test results is summarized.

Additional recommendations are given for further test work to help form the basis of future H_2O_2 supported combustion chamber design. A possible method of more economical testing of combustion chambers is proposed.

C O N F I D E N T I A L

C O N F I D E N T I A L

I. INTRODUCTION

During World War II a gas generating turbine system utilizing high strength hydrogen peroxide, fuel, and water was developed by Germany for submarine propulsion. By the end of the hostilities, many sea trials with the submarines had been conducted, but the craft had not reached the operational stage of development. A complete propulsion system was brought to this country in 1945. Tests conducted at the Engineering Experiment Station, Annapolis, Md., with the German equipment proved that the application of high strength H_2O_2 and fuel for submarine propulsion was feasible. The German system utilized 83 per cent H_2O_2 (17 per cent by weight water) and synthetic Diesel fuel. At a chamber pressure of 500 psig 2500 shaft horsepower could be developed with the steam turbine-reduction gear arrangement.

Starting in 1946, a new propulsion system similar to the German plant was built by Allis-Chalmers Mfg. Corp. and was designated the Alton Cycle. It was installed in a submarine hull mock-up. The Alton Cycle was originally designed to produce a maximum of 7500 shaft HP at 750 psig chamber pressure and 1300°F combustion chamber discharge temperature. Early in the test program, the output power rating was increased to 10,000 shaft HP at the same exhaust temperature and chamber pressure. Full power operation was to be sustained for 10 hours. The combustion chamber (Figure 1) was fed with decomposition products of 90% H_2O_2 , Diesel fuel, and water. The H_2O_2 was first decomposed in a catalyst chamber into steam and oxygen at 1360°F. Fuel was injected into the decomposition gases as they entered the combustion chamber. Ignition of the Diesel fuel occurred without the help of an igniter because of the high temperature of the decomposition gases. The diluent water which circulated through the catalyst and combustion chamber cooling passages was sprayed into the combustion gases just above the combustion

C O N F I D E N T I A L

C O N F I D E N T I A L

chamber outlet to reduce the exhaust temperature to 1300°F.

On 1 March 1954, the development project of the Alton Cycle was terminated. At the time of work termination, the only component of the system that required further testing was the combustion chamber. Operation at 750 psig chamber pressure resulted in combustion chamber liner burning. Efforts to prevent liner damage, increased cooling water velocity, thinner liner walls, more heat resistant material for liner composition, larger liner diameter at the combustion zone, swirl imparted to the fuel spray, elimination of helical fins or other guide fins in the cooling passages, and the use of Solaramic coating for the inner liner surface, were unsuccessful.

As a result of a conference held on 5 May 1954 at ONR, Washington, D. C., Becco submitted a proposal to ONR to conduct a complete study of the Allis-Chalmers chamber failure and to recommend steps to prevent burnouts. The contract awarded to Becco on the basis of the proposal was designated Nonr 1187(00). On 1 July 1954, a research project sponsored jointly by BuShips Research and Development Section and the Office of Naval Research, Power Branch, commenced at the U. S. Naval Engineering Experiment Station, Annapolis, Md., (E.E.S.) to develop a reliable combustion chamber for the Alton Cycle. Becco's basic contract was amended to provide consulting services during the total time of the project at E.E.S. which terminated on 1 July 1956.

This report will, in part, summarize the information presented in Becco Report NR-1 titled, "Preliminary Analysis of Burnout Failures of the Alton Cycle Combustion Chamber CC-12", issued in January 1955.

In addition, the report will provide a description of the test system and the results of the runs made at E.E.S. The information will parallel the report prepared by E.E.S., but is presented here to act as a background for the modifica-

C O N F I D E N T I A L

C O N F I D E N T I A L

tions advocated by Becco and EES personnel. The results of a short H₂O₂-Diesel fuel combustion study conducted late in the contract period at Becco and final recommendations for the combustion system run at EES are also included.

II. ALTON CHAMBER ANALYSIS AND MODIFICATION RECOMMENDED

Based on experience gained through bunker testing at EES from 1948 to 1950 a prototype combustion chamber designated as CC-12 was designed in 1950 to be fabricated from 347 stainless steel. (Fig. 1) The CC-12 chamber completed a total of about 10 hours of successful operation in bunker tests of short duration during 1951 and 1952. In 1953 the chamber was operated a total of approximately 23 hours during 62 test runs in the submarine hull mock up. In the latter series of tests the general trend was increased power development for successive runs. Runs 59 thru 62 were made at 735 psig turbine inlet pressure which is approximately full power. In the 63rd test run, which was scheduled for 10 hours at full power, the exhaust temperature and pressure began to decrease after 3 hours and 7 minutes on test. The unit was secured. Examination of the chamber liner revealed numerous holes and severe burning in the conical head section and approximately 1/64" of scale on the water side of the liner.

The chamber was repaired and modified by replacing the 347 stainless steel conical section of the liner with a ceramic-coated 35-20 stainless steel section of the same dimensions. The ceramic-coated 35-20 stainless steel was expected to be more heat resistant. The conical head of the liner burned out after a few minutes of operation at 700 psig in run No. 65.

The liner was then made up with 1/8" nickle wires to control the coolant flow pattern over the head section. The water passage clearance between the head and jacket was reduced to 1/8" (Figure 2). The liner showed signs of burnout after 5 minutes operation in run 68 which was made at 728 psig turbine inlet pressure.

C O N F I D E N T I A L

Best Available Copy

C O N F I D E N T I A L

A new fuel nozzle was then installed with holes at an angle to both the vertical and horizontal axis of the nozzle in the same direction as the swirl pattern of the decomposition gases (Figure 3). The thickness of the 317 stainless steel in the head section was also reduced .030" to an average of .295". Operation for 8 minutes at 720 psig in run 71 resulted in severe liner burning.

The next modification consisted of reducing the liner wall thickness to an average 1/8 of an inch. Runs 72 thru 76 with operation at 650 psig were successful. Three hours operation at 650 psig in run 75 caused liner burnout.

A new chamber was evaluated in runs 77-80 (Figure 4). The lower diameter of the conical head section was increased from 10 to 10-3/4" thus tending to give the liner a bell shape. The cone angle of the head was slightly wider. The cooling water passage width and liner thickness were both 1/8". It was hoped that the flame would maintain its previous dimensions leaving a space of no combustion next to the walls at the turn of the belled section. After runs 78 and 80 at 500 and 600 psig evidence of metal flow was found in the head section.

The EES combustion chamber CC-13 was then installed. (Figure 5) Liner material was 25-20 stainless steel, 7/64" thick. Chamber pressure was increased during runs 81-83. Run 84 was made at 600 psig for 5 minutes. Liner inspection after the run disclosed that the liner had collapsed inward in the lower part of the straight section. No burning at the heel was noted. The Alton test program was terminated with run 84.

At the outset of Becco contract work a heat transfer analysis of the Alton combustion chamber⁽¹⁾ using data from run 68. Table I was performed and Becco submitted a modified and completely instrumented (thermocouples and pressure taps) liner design (Figures 6 & 7).

(1) "Preliminary Analysis of Burnout Failures of Alton Cycle Combustion Chamber CC-12" Technical Report NR-1, Becco Chemical Division, January 1955

C O N F I D E N T I A L

Best Available Copy

C O N F I D E N T I A L

A preliminary heat transfer analysis of the Alton chamber was presented by Becco at a conference held on 19 July 1951 at EES. The liner design drawings were sent to EES in August 1951. The principle features of the proposed liner design were as follows:

- a. A flat type head was recommended to reduce the gas velocity in the zone where burning occurred in previous tests. This reduced velocity would decrease the heat transfer film coefficient on the gas side of the liner and consequently reduce the temperature at the surface of the liner.
- b. The cross-sectional area of the cooling water annulus in the head section was increased from $1/8"$ to $\approx 1/4"$. This change was designed to allow gas bubbles formed by boiling to escape without being trapped and causing a hot spot. The elimination of gas bubbles was deemed more important than the higher water velocity attained with the $1/8"$ dimension.
- c. The helical cooling fins were extended to the top radius, thus providing more heat transfer area and higher water velocity beyond the area where most severe burning occurred with the Alton cycle liners. Continuing the helical cooling fins to the throat had previously been found to be unsatisfactory.

An extensive thermocouple installation on the outer surface of the inner liner was proposed in order that the affects of the fuel nozzle and liner design variables could be obtained quantitatively and with a minimum of testing. It was hoped that the tests with the instrumented liner would serve as a guide in determining which design changes would be best in carrying on a successful test program. The recommended liner design and thermocouple installation were incorporated in the combustion chamber development program.

Additional recommendations for the program were included in report NR-1. The use of nickle "A" or Rosslyn metal instead of stainless steel for liner fabrication would decrease the liner temperature on the gas side through the increased thermal conductivity

C O N F I D E N T I A L

Best Available Copy

C O N F I D E N T I A L

of the nickle "A" and Rosslyn metal. Elimination of scale on the water side of the liner was considered to be one of the most important factors in successful operation of the chamber. The continued use of a closed water system was suggested in order to reduce the scale buildup. The angle of fuel injection could be investigated to reduce the direct impingement of burning fuel on the liner walls. The effect of inlet oxidant gas swirl might also be evaluated.

The recommendations given in report NR-1 were based, in part, on the advice solicited from individuals outside of Becco who were experienced in the field of high energy release combustion systems and heat transfer.

These individuals were contacted during the period July 1954 - January 1955. Additional information was gained by Mr. Ralph Bloom, Jr., of Becco, on a trip to the United Kingdom in January of 1955⁽²⁾. Thus the background for consulting services that Becco had gained through previous test work at Becco was augmented by several sources.

III. TEST SYSTEM AT EES

The test system employed at EES for the combustion chamber tests is presented schematically in Figure 8. The system was installed in a test bunker at one end of the building. A reinforced concrete wall separated the system from the operating station. The instrumentation that was incorporated is given in Table II.

The complete H_2O_2 flow system was as follows:

a. H_2O_2 was pumped from 30,000 gallon storage tanks to a small "day tank" which had sufficient capacity for approximately one hour of chamber operation. The large storage tanks and day tank were located in a separate building and are not shown on the schematic diagram of the system.

(2) British Submarine Plant Combustion Chamber and Other Hydrogen Peroxide Developments Report of Visit to Great Britain, 31 January - 16 February 1955.

C O N F I D E N T I A L

C O N F I D E N T I A L

b. From the day tank the H_2O_2 flowed down through a degassing pot to the H_2O_2 booster pump. The degassing pot removed any gas entrained in the H_2O_2 .

c. After passing through a proportioning device the H_2O_2 reached the suction side of the triple feed pump. The triple feed pump consisted of three positive displacement pumps, one for each of the system fluids driven by a single motor through speed increasers. The pump raised the liquid pressure from the 30-40 psig discharge pressure of the booster pumps to about 200 psig above combustion chamber pressure. The flow of H_2O_2 through the proportioning device controlled the flow rates of the cooling water and fuel in preset ratios.

d. From the triple feed pump discharge the H_2O_2 passed through a two way air-operated pressure valve. Actuation of the valve by-passed the H_2O_2 flow back to the degassing pot.

e. Normally the H_2O_2 passed through the two-way valve to a throttle valve which was operated from the main control panel located outside the bunker.

f. Next the H_2O_2 reached a cam stop valve. The cam valve was also manipulated from the main control panel. The hand wheel had 4 positions: off; No. 1, H_2O_2 only; No. 2, H_2O_2 and cooling water; No. 3, H_2O_2 , water and fuel.

g. After passing through the cam stop valve the H_2O_2 entered the catalyst chamber. The water system was a closed loop with the following flow sequence:

- a. The water booster pump took suction from a feed tank located inside the bunker. A strainer was installed in the line to help prevent scale build-up on the combustion chamber liner.
- b. The water booster pump discharged through a filter to the triple feed pump suction.

C O N F I D E N T I A L

C O N F I D E N T I A L

- c. From the triple feed pump the water entered the proportioning device where the water flow rate was controlled in a ratio of approximately 2 to 1 gpm of H_2O_2 flow.
- d. Water flow from the proportioning device entered the cooling water passages of the combustion chamber and catalyst chamber in that order.
- e. Part of the water discharge from the catalyst chamber could be circulated through a cooler and pumped back to the combustion chamber inlet to increase the flow of coolant through the cooling passages.
- f. The heated cooling water then passed through the cam operated valve and entered the water spray arrangement located inside and at the bottom of the combustion chamber.

The fuel system followed a similar path from storage tank, booster pump, filter, triple feed pump, proportioning device, cam valve, and solenoid valve to the fuel nozzle located at the top of the combustion chamber in the flow of decomposition gases.

The combustion chamber exhaust passed through the following units in order:

- a. Steam separator - removed entrained liquid or solid particles that would harm the turbine of a complete propulsion system.
- b. Orifice - simulated the pressure drop through the turbine.
- c. Desuperheater - supplied the reduction in temperature of the turbine exhaust.
- d. Condenser - as in the Alton cycle.
- e. Condensate pump
- f. Water feed tank.

During operation of the combustion system the excess water produced was dumped down a drain.

The test system incorporated a trip out circuit (Figure 9) both for safety of operation and ease of shutdown. The entire system could be secured by a manual switch

C O N F I D E N T I A L

C O N F I D E N T I A L

on the main control panel or would trip out automatically in the event of:

- a. loss of control air pressure
- b. loss of triple feed pump lube oil pressure
- c. excess temperature of exhaust either in steam separator or exhaust line loop.

When the trip out circuit was opened either with the hand switch or because of emergency conditions, a, b, or c above, the triple feed pump and booster pumps were shut off, a solenoid valve in the fuel line to the combustion chamber stopped fuel flow and the air operated H_2O_2 by-pass valve stopped the flow of H_2O_2 to the catalyst chamber.

In addition, red warning lights installed on the main control board flashed on in the event of:

- a. loss of lube oil pressure to triple feed pump
- b. loss of control air pressure
- c. loss of condenser vacuum
- d. high temperature, triple feed pump lube oil
- e. excess pressure in steam separator
- f. loss of seawater pressure to condenser
- g. high temperature, water to catalyst chamber cooling passages
- h. high temperature, H_2O_2 after throttle valve

IV. PRELIMINARY TESTING

The installation of the test system at EES was completed in early January 1955. The catalyst bed used during the later Alton runs was reactivated with samarium nitrate. The bed consisted of 4 - 10 inch diameter silver spirals each 2-1/2 inches thick. The first few preliminary runs at EES were operated with decomposition only; no fuel was injected. The catalyst bed functioned as desired. On 24 January 1955 the first combustion run was made at 300 psig combustion pressure employing a fuel nozzle that had been used in the Alton runs (Fig. 3) and with a chamber configuration as indicated

C O N F I D E N T I A L

C O N F I D E N T I A L

by Figure 10. The run was designated 1-12B. Inspection of the combustion chamber liner after the run revealed that no damage had occurred due to overheating of the metal. The Teflon tips of the wall temperature thermocouples were found to be crushed by the expansion of the liner during combustion. It was decided by EES and Becco to replace the Teflon tipped thermocouple arrangement before the next run with wires peened into shallow holes drilled in the outside of the liner. Thermocouple location and number designation is given in Figure 11.

The second run, 2-12B, was conducted on 3 February 1955. Chamber pressure was raised to 450 psig. The thermocouple installation was found to be satisfactory although the wall temperatures were lower than recorded in run No. 1 and the difference between readings for thermocouples in the same plane was as much as 400°F. The insulating affect of the Teflon tips accounted for the lower wall temperatures in run No. 2 but no explanation could be advanced for the large difference between readings of thermocouples installed in the same plane. Each wall temperature reading remained essentially constant after a rapid rise when combustion was initiated.

Chamber pressure was increased for each of runs 3, 4, and 5-12B to 650 psig in run 5-12B. Data summary for run No. 5-12B is given in Table III. The liner was removed after run No. 5 for inspection. Metal flow was present in two areas about 120° apart and approximately 2 inches below the beginning of the straight section. A red oxide deposit was present in the dome, extending about an inch below the beginning of the straight section. This was followed by a black carbon deposit around the circumference of the liner, about 1-1/2 inches wide. After inspection, the liner was cleaned of all deposits.

The test procedure developed consisted of the following major steps:

- a. booster pumps on
- b. triple feed pump on, low speed

C O N F I D E N T I A L

C O N F I D E N T I A L

- c. H₂O₂ throttle valve opened part way
- d. H₂O₂ cam valve opened - decomposition started
- e. combustion chamber pressure from decomposition increased to approximately 150 psig
- f. water cam valve opened briefly to check correct operation of water system. Water cam valve closed. (Diluent water flow indicated by rapid drop of exhaust temperature. This check was made as a precaution against combustion without cooling water which would result in immediate severe damage to the combustion chamber. The recirculation of water through a heat exchanger was maintained during startup),
- g. water and fuel cam valve opened almost simultaneously. Combustion initiated.
- h. visual observation of the test system was made through peep holes in reinforced wall between operating station and combustion chamber. Instrument operation checked.
- i. booster pumps and triple feed pump speeds increased until desired chamber pressure attained. Average length of starting sequence approximately 2 min. The water cooler could be by-passed if and when desired.
- j. readings taken off non-recording instruments on signal. Data points marked on recording instruments. Orsat analysis samples taken.
- k. triple feed pump speed decreased until chamber pressure reached approximately 150 psig.
- l. hand trip switch opened - fuel flow stopped, triple feed pump off, booster pumps off, system secured. Recording instruments off. (stopping sequence duration \approx 80 seconds).

C O N F I D E N T I A L

C O N F I D E N T I A L

m. H_2O_2 lines from day tank to combustion chamber drained if no further runs were to be made the same day.

During the period that the first five runs were made, Becco contracted Professor Warren Rohsenow of MIT as a consultant on the test program. Professor Rohsenow had been associated with the program under consulting contract with EES. Arde Associates, an engineering consulting firm, in Newark, New Jersey was also contracted at this time by Becco to make a preliminary analysis of the fuel spray pattern for the fuel tip, and chamber configuration utilized in runs 1-5-12B. (3)

After run No. 5 Becco obtained thermocouple wires that were insulated and bound together so that a single hole thermocouple packing gland could be used, reducing the time required to install the thermocouples. A double hole packing gland had been in use. After the thermocouple wires were peened into the liner wall, installation of the liner in the combustion chamber jacket was complicated by the need to pull the thermocouple wires out through holes in the jacket and then thread the wires through the two hole packing glands.

After run No. 5-12B the Becco representative at EES suggested a light and mirror arrangement that would permit inspection of the liner in place after the catalyst chamber was removed. The method was employed in subsequent tests. The liner was removed from the combustion chamber jacket only for repairs.

(3) Arde memorandum "Alton Combustion Chamber" March 11, 1955

C O N F I D E N T I A L

C O N F I D E N T I A L

V. RESULTS OF TEST RUNS AND CONFERENCES HELD AT EES DURING THE TEST PROGRAM

A. Conferences and Results of Test Runs #6-71-12B

A conference was held at EES on 11 March 1955 to discuss the results of Runs 1-5-12B and to determine the procedure to follow in future test work. It was generally accepted that the burning of the liner was due to liquid fuel hitting the walls and burning there. The EES representatives pointed out that changing the position of the fuel nozzle would not be a desirable method of preventing liquid fuel from reaching the walls. Tests with the Alton system had shown that the nozzle position was critical; either raising or lowering even slightly, adversely affected combustion efficiency. For the next test runs it was decided to first double the number of holes in the fuel nozzle to reduce the fuel droplet velocity. If the increased number of fuel holes would not prevent burning, the H₂O₂ gas swirl vanes on the fuel inlet pipe were to be removed. As a last step the gas swirl in the discharge from the catalyst chamber was to be eliminated. It was also agreed that Arde Associates would be contracted by Becco to make a complete analytical analysis of the fuel injection and design a new fuel nozzle to eliminate liquid fuel from reaching the wall.

The test program was resumed with runs 6 and 7 employing a fuel tip with the number of holes in the periphery of the nozzle increased from 12 to 24 and the diameter of the holes increased from .0625 to .067 in. The chamber pressure for runs 6 and 7 was 650 psig and time on fuel was 26 and 31 minutes respectively. Inspection of the liner after run No. 6 revealed a red oxide deposit as noted for runs 1-5, extending from the silver deposit on the inlet neck to about 1-1/2 inches down the straight section. There was no evidence of metal burning, flow, or slag deposits. After run No. 7 the liner was slightly pitted about 1/2 inch below the neck. A very slight evidence of metal flow was observed approximately 2 inches down the straight section about 2 inches wide. Runs

C O N F I D E N T I A L

C O N F I D E N T I A L

Runs 6 and 7-12B showed marked improvement over runs 1 through 5-12B (reduced liner temperatures with approximately the same combustion efficiency) but the evidence of metal flow in run 7 indicated the need for further changes.

Following run 7-12B the fuel nozzle was modified by adding 12 - 1/16" dia. holes in the bottom of the nozzle parallel to the chamber axis (Figure 12) to further reduce fuel injection velocity. Run No. 8 at 610 - 670 psig chamber pressure for 24 min. with the 12 additional holes in the bottom of the nozzle resulted in more serious scale formation and pitting at the top of the liner dome. Metal flow in small rivulets was present around the entire circumference of the liner about 1-1/2 inches down the straight section. Run No. 10-12B was conducted with the number of holes in the bottom of the fuel tip decreased to 4 as recommended in Becco's letter of 4 April 1955 to the Director of EES. No data was taken during run No. 9 because diluent water pressure was lost soon after the start of the run. A repeat run, No. 10, caused increase in the metal flow and pitting observed after run 8-12B. The liner was cleaned of all deposits after run 10.

Runs 11 and 12-12B were run with all holes in the bottom of the nozzle plugged except the central drain hole and the diameter of the 24 peripheral holes increased from .067 to .070 inches. Run No. 11 was conducted at 610 psig chamber pressure. The chamber pressure was increased to 650 psig during run No. 12; time on fuel for each run was about 14 minutes. The liner was inspected after run 12-12B and slight pitting was found just below the inlet neck. Run 13 was made at Becco's suggestion with decomposition gases alone and indicated that the liner wall temperatures were highest at the beginning of the straight section of the liner as noted for the previous combustion runs. The run indicated that the liner burning problems were related to the H_2O_2 decomposition gas flow patterns in the chamber caused by the swirl vanes on the fuel nozzle.

C O N F I D E N T I A L

CONFIDENTIAL

Runs 14-12B through 17-12B were conducted with the fuel nozzle modified with the "EES baffle". (Figure 13) The baffle was added to deflect the fuel spray away from the liner walls. Since the maximum wall temperature readings during runs 14 and 15-12B at 650 psig were near those observed for runs 6 and 7 the combustion pressure was raised to 750 psig (maximum design operation pressure) during runs 16 and 17-12B. The inside of the combustion liner was inspected after each run and no burning was noted. Wall temperature readings were closer to those of runs 6 and 7-12B than any of the intervening runs but still higher.

Run 18-12B was conducted with no decomposition gas swirl vanes on the fuel inlet and a fuel nozzle design conforming with that of runs 6 and 7-12B (24 - .067 holes on periphery plus 1/16" diam. hole). Ignition of the fuel was attained but the combustion efficiency was poor, with Orsat measured CO_2 at 29.6% versus approximately 36% for all previous runs. Thus the need for a configuration such as the swirl vanes to provide turbulent mixing of decomposition gases and fuel spray was clearly indicated.

Run No. 19-12B demonstrated that the results of runs 14 and 17-12B with nozzle 12-BF (Figure 13) could be reproduced; no changes had occurred as a result of run 18-12B. No data was taken during runs 20 and 21 because of malfunction of the proportioning device. Run No. 22-12B with nozzle 12-BF was made to check out the repaired proportioning device and to see if liner burning would occur during a more extended run. Time on fuel for this run 22 was 47 minutes. The longest previous run with nozzle 12-BF was 26 min. 40 sec. in run 16-12B. But because the liner wall readings were above those in runs 6 and 7 in which liner burning occurred, the need for further modifications was indicated.

Run 23-12B incorporated a coaxial baffle arrangement without the fuel inlet swirl vanes that had been proposed by Berto (Figure 14). It was hoped that the coaxial

CONFIDENTIAL

C O N F I D E N T I A L

arrangement would provide an inner layer of decomposition gases next to the liner and adjacent the fuel nozzle and outer the liner. The nozzle was modified 18-B3A. The test was run at 430 psia with a duration of 12 min. 30 secs. The CO₂ percentage of the non-condensibles of the exhaust gases was 61.3 which showed an improvement over the plane nozzle with gas swirl removed (run 18-12B). The liner was examined and found to be in satisfactory condition.

A second conference was held at ENS on 26 May 1955 to discuss the test results obtained since the conference on 11 March 1955. Arde Associates reported the preliminary results of the analytical investigation of the fuel injection for review and comment. The results up to the time of the meeting indicated that the fuel droplet size and consequently droplet penetration to the liner walls is mostly dependent on chamber pressure. The formula used for droplet size calculations was questioned but it was agreed that no better formula was available. The effect of the fuel inlet swirl in increasing the heat transfer coefficient in the head section by reducing the gas film thickness was also discussed. A threefold increase was accepted as possible. It was decided that investigation of factors that affected liner life and combustion efficiency be continued even if such an investigation would eliminate the possibility of a 10-hour run with the H₂O₂ that was on hand. (The program was started with a limited amount of H₂O₂ and no funds were provided to purchase more) It was further agreed that additional study of fuel inlet velocity (changing tip hole size) was not practical because further improvements apparently would be too small to be detected within the experimental variations. Increasing the fuel tip holes from .067 to .070 inches in diameter had resulted in only slight changes in the liner thermocouple readings. In summary, future tests were to be directed toward attainment of sufficient mixing to provide a CO₂ content in the non-condensibles of the exhaust of at least 90% by volume while eliminating extreme velocities in the space of the combustion wall. One approach to the

C O N F I D E N T I A L

C O N F I D E N T I A L

problem was to be the addition of turbulence inducing devices to the Becco coaxial baffle (Figure 15).

Run 24-12B made on June 2, 1954, was made with a coaxial baffle of the same dimensions as nozzle 12B2A evaluated in run 23-12B but included the gas swirl vanes on the fuel inlet pipe. Average chamber pressure was 427 psig; time on fuel was 22 min. 45 sec. The results were discouraging. CO₂ measured by Orsat analysis was almost the same as run 23. The readings averaged 61.7%. The lower edge of the baffle was melted off and the inlet neck of the liner was severely burned just above the weld between the neck and the dome. The liner was also burned at its lower end where it is backed with packing.

After the liner was repaired run 25-12B was made with a small coaxial baffle with a turbulence ring added to the lower end of the baffle. The swirl vanes on the fuel inlet were removed. (Figure 15). Combustion was not satisfactory, 70-80% CO₂. No liner or baffle damage occurred.

For run 26-12B a 1/8" wire cross was added to the turbulence ring (Figure 16). The cross burned off and combustion was satisfactory, CO₂ 79%.

Run 27-12B evaluated a Becco proposed turbulence donut baffle welded to the fuel nozzle which was positioned to reduce the fuel spray angle, a change evaluated previously in runs 14 through 17-12B and 19 through 22-12B (Figure 17). The run was made at 600 psig chamber pressure for a duration of 40 min. 15 sec. CO₂ was 89.6%; wall temperature readings were low 130-305°F; no liner or fuel tip damage occurred. The run 27-12B was considered more encouraging than any previous test. This baffle was designed to create fuel and oxidant mixing by directing the decomposition gas stream to the center of the chamber.

Run 28-12B was made as a control check against run 27-12B. The run was made

C O N F I D E N T I A L

C O N F I D E N T I A L

with the fuel nozzle configuration used in runs 11 and 12-12B. The resulting wall temperatures and CO₂ were similar to the data of runs 11 and 12. A hole was burned in the dome of the liner.

A third conference was held at EES on 7 July 1955. Runs 24-12B through 28-12B were reviewed. The burning of the lower end of the liner where it is backed with packing in run 24-12B was attributed to contact with burning droplets of molten metal from the baffle and the liner neck. It was felt that the hole burned in the liner dome in run 28 resulted from the decreased cooling water passage width at the dome which was caused by the repair of liner damage from run 24-12B. The conference discussed the need for a new liner, because the EES engineers felt the liner in use was near the end of its life. Becco had been in contact with the Youngstown Welding and Engineering Corporation of Youngstown, Ohio, concerning the fabrication of a liner from Rosslyn metal. The contact resulted from Becco's search for a material suitable for liner fabrication and which had a greater heat transfer coefficient than stainless steel. The price of the Rosslyn metal liner, was approximately twice the cost of fabrication of a 25-20 stainless steel liner from stock that was on hand at EES. It was resolved to make a new liner out of the 25-20 stainless steel for economy reasons.

The ONR representatives pointed out that the entire Alton propulsion unit would be held in reserve until such time as it might be needed in the case of serious national emergency. The need for at least a 5 hour, full load, continuous test run was also stressed.

Arde Associates presented a counter swirl fuel nozzle jacket design that was accepted for fabrication and test. It was decided that the next runs were to be made with turbulence rings added to the bell baffle that had given good results in run No. 27-12B after the results of run 27 were shown to be reproducible. These turbulence

C O N F I D E N T I A L

C O N F I D E N T I A L

rings were to increase mixing and thus improve combustion efficiency. It was hoped an optimum design would be indicated.

Run 29-12B on 22 July 1955 demonstrated the reproducibility of run 27-12B. In general, runs 30 through 45-12B, evaluated the addition of turbulence rings of increasing thickness to the ball baffle (Figure 18). The affects of closing the 1/16" drain hole in the center line of the nozzle and the addition of two holes in the bottom of the tip plus the drain hole were also determined. One other slight modification evaluated during runs 43 through 45-12B (Figure 18). During the series of tests 29 through 45-12B, which were completed on October 12, 1955, difficulties were encountered both with the catalyst bed and the proportioning device. No light off was attempted during runs 36, 38, 39, and 41-12B because of excessive pressure drop across the catalyst bed. The bed was changed for run 37 and activated for runs 39, 40, and 42-12B. Some of the successful runs had to be re-run because of oxidant rich operation due to malfunction of the proportioning device.

Runs 29 to 45-12B yielded the following results:

- (a) The optimum arrangement of ball baffle and turbulence ring occurred when the gap between the liner throat and turbulence ring was 1/4 in. With the 1/4" gap the CO₂ was 92-93%.
- (b) Plugging the fuel tip drain hole reduced performance.
- (c) Addition of 2 1/16" diameter holes to the bottom of the fuel tip reduced performance.
- (d) Increasing the spray angle of the fuel slightly by cutting back the bottom of the ball baffle (runs 43-45-12B) did not affect performance.
- (e) No liner burning or fuel tip melting occurred.

Run 46-12B on 18 October 1955 evaluated the Arde dual swirl nozzle (Fig. 19). Performance was fair with 91.8% CO₂ but the lower end of the nozzle was burned.

C O N F I D E N T I A L

C O N F I D E N T I A L

The next series of tests, runs 48 through 53-12B were made with a 3" diameter ring baffle that gave at first, a 1/4" clearance between the ring and the liner throat. (Figure 20) Additional modifications made to the 3" ring baffle during the runs are indicated on Figure 20. Runs 48-53-12B which were completed on 7 November 1955 gave results that were inferior to the optimum arrangement of small ring baffle and turbulence ring.

During the fourth conference held on 8 November 1955 at EES it was agreed that a successful 5 hour run could be made with the small ring baffle plus turbulence ring. The 5 hour run would have to wait until the new liner was completed. In view of the poor results of runs 48 through 53-12B it was decided to machine a ring baffle with the same shape and dimensions as the baffle with added turbulence ring that had given the best results and to check the reproducibility of those results.

Runs 54 through 56-12B were made in accordance with the decisions of the 8 November conference. The fuel nozzle employed is shown in (Figure 21). Guide vanes were installed on the fuel inlet pipe in runs 54 and 55-12B. Run 54-12B at 650 psig chamber pressure was without incident; CO₂ was 91.8%. The new liner (EES designation - No. 4) which was designed by Arde Associates⁽¹⁾ was installed for run No. 55-12B. The changes made to the previous design were as follows:

- (a) reduction of wall thickness to 1/8" (from 3/16" in the present liner)
- (b) reduction of fin height to 3/8" (from 5/8" in the present liner)
- (c) increase in liner I.D. to 10-3/8" to incorporate (a) and (b) above and maintain the transverse dimension of the previous liner, 11-3/8".

(1) "Modified CCl₂ Liner Design", Arde Associates, Report No. 4553-1 26 July 1955

C O N F I D E N T I A L

C O N F I D E N T I A L

In run 55-12B at 645 psig for 3 min. 48 sec. burning occurred at the lower end of the liner where it is backed with packing. The burned area was directly below the fuel inlet pipe elbow. The fuel injector assembly was found to be tilted slightly toward the burned area. Guide lugs were added to the ball baffle for run 56-12B in an attempt to prevent tilting of the fuel injector. In run 56-12B on 11 January 1955, which was conducted at 650 psig chamber pressure for 6 min. 5 sec., additional burning of the bottom of the liner occurred in two areas directly above diluent spray nozzles.

A fifth meeting was held at EES on January 19, 1956, to discuss the liner damage caused by runs 55 and 56-12B. Becht presented two methods of providing more positive cooling about the entire inside diameter of the liner at its lower edge. One method was to add a cooling water ring just above the critical section. The ring would be supplied by four pipes one from each of the four diluent nozzles (Figure 22). The second approach would be to install a single water spray nozzle to replace the four nozzles that had been in use (Figure 23). The addition of a gas deflector ring to deflect gases away from the dead space provided for liner expansion was also discussed as a means of preventing burning. Improvements to the Arde dual swirl nozzle were advanced since this nozzle was still believed to be of superior design. Steps for the next runs were agreed to and were carried out in runs 57 through 62-12B.

Run 57-12B was made with a slightly modified Arde dual swirl fuel nozzle. High combustion efficiency was obtained, 97.2% CO₂, but serious burning in the dome of the liner occurred. For run 58 the donut baffle fuel nozzle (Figure 21) was reinstalled and a gas deflector ring was installed just above the diluent nozzles. The deflector ring was installed to prevent gas and/or unburnt fuel from collecting in the dead space provided for liner expansion. The ring burned off almost completely during the test.

During runs 59 and 60-12B the 4 diluent water spray nozzles were baffled

C O N F I D E N T I A L

C O N F I D E N T I A L

In an attempt to provide complete liner wall coverage. During run 60-12B minor liner burning near the diluent nozzles occurred. It was agreed that the baffling of the H_2 nozzles was not a satisfactory approach.

For runs 61 and 62-12B the cooling water ring and H_2 diluent nozzle arrangement was evaluated. Burning of the liner at its lower end was successfully prevented at 650 psig chamber pressure for a total run time of about 24 minutes. Data was obtained in run 62-12B for liner wall and jacket temperature changes that had been noted previously in runs 56, 60, and 61 (Table IV). The temperature changes occurred rapidly after varying periods of operation while the system feeds, pump pressures, etc. remained essentially constant. The liner wall and jacket readings remained steady before and after the change. It appeared that the region of most intense heat release suddenly dropped lower in the chamber because of some change in the character or geometry of combustion independent of the external system. The change was marked by a decrease in CO_2 . The phenomena was of concern because it was an indication of unstable combustion.

Runs 63 through 65-12B evaluated the Becco "umbrella" diluent nozzle (Figure 23) one central nozzle replaced the H_2 nozzles used previously. The nozzle had been installed lower than Becco had recommended. Minor liner burning at its lower end occurred during run 64-12B. A deflector ring was added to the nozzle to depress its spray for run 65-12B. Severe liner damage resulted. The bottom of the liner was completely melted around one half of its bottom circumference. The burning extended from the bottom of the liner up to a point corresponding to the height of the packing backing the liner. The liner was removed for repairs. The central nozzle idea was abandoned because the H_2O_2 available for testing was limited and the addition of the cooling ring had proved successful. Becco felt that the central nozzle could be made to work by increasing its height above the bottom of the chamber.

C O N F I D E N T I A L

C O N F I D E N T I A L

The old liner that had been used early in the test program was installed for run 66-12B and the 4 nozzle, cooling ring arrangement was tested at 700 psig chamber pressure. No burning or liner wall temperature shift occurred during 11 minutes of operation. CO₂ was 91.4%.

The percentage of CO₂ in the non-condensibles of the exhaust gas decreased from approximately 94% at 650 psig to 91% at 700 psig chamber pressure. It was decided that more intense mixing of the decomposition gases and fuel spray was needed to keep the CO₂ above the accepted minimum of 90% when full power operation at 750 psig chamber pressure was attempted. Becco felt that additional turbulence would prevent the liner wall temperature changes that had occurred previously. Prior to run 67-12B, twelve 45° angle slots, each 3/32 of an inch wide, were cut in the lower end of the donut baffle in order to increase the turbulence (Figure 24).

Data was taken at 650 and 750 psig chamber pressure in run 67-12B. The percentage of CO₂ of the non-condensibles of the exhaust gases was 94.0 and 90.5 respectively. The slots in the fuel nozzle did not increase the CO₂ but were successful in preventing the liner wall temperature change. No liner burning occurred.

Four small swirl vanes were then added to the slotted ring baffle in an effort to improve mixing (Figure 25). The swirl vanes improved the combustion in run 68-12B. The CO₂ was 95.9% at 650 psig chamber pressure. The same fuel nozzle was evaluated in liner No. 4 in run 69-12B. CO₂ was 97.2% at 675 psig chamber pressure but slight burning of the liner dome occurred. The swirl vanes were reduced in width for run 70-12B with liner No. 4. No burning occurred in run 70 but there was little performance increase over the slotted ball baffle without the swirl vanes.

After run 70 it was apparent that an extended run could be attempted using liner No. 4, the slotted ball baffle fuel nozzle, and the 4 nozzle, cooling ring, diluent water arrangement. The length of the final extended run was reduced from 10 to

C O N F I D E N T I A L

C O N F I D E N T I A L

5 hours and finally to 2-1/2 hours based on the amount of H_2O_2 expended for the development of a satisfactory combustion chamber configuration. ONR's decision to go ahead with the extended run was prompted by the H_2O_2 that was on hand and also by the desire to complete the program by June 30, 1956. A brief check out run and the final 2-1/2 hour test are described in the next section.

B. Results of Test Runs 71 and 72-12B

Run No. 71-12B was conducted to verify the assumed trouble-free operation of the combustion chamber configuration consisting of the slotted ball baffle fuel nozzle, liner No. 4, and the cooling ring, 4 nozzle diluent spray. The slotted ball baffle fuel nozzle had not been evaluated in liner No. 4. The results of run 71-12B, no liner burning or liner wall temperature changes, 94.5% CO_2 at 660 psig chamber pressure, and stoichiometric fuel and H_2O_2 proportioning, demonstrated that the long run could be attempted. Data summary for run 71-12B is given in Table V.

It was decided by EES and Office of Naval Research representatives that the final run would not be made at full rated power with a combustion chamber pressure of 750 psig. Instead, to help insure a successful test, the flow rate was to be limited so as to hold the chamber pressure at approximately 650 psig for a duration of 2-1/2 hours.

The final run was made on 7 May 1956. Data summary is given in Tables V and VI. With reference to the data summary, the variation in chamber pressure readings was due, in part, to an accumulation of foreign material found after the run in the line to the Bourdon tube pressure gage and the continuous recorder. The Bourdon tube pressure gage located on the main control panel showed decreasing chamber pressure after completion of approximately half of the run because of the restrictions in the line. The operators increased the flow rates when the false decrease in chamber pressure was noted. The chamber pressure also varied as a result of slight changes

C O N F I D E N T I A L

C O N F I D E N T I A L

in the diluent water flow to the nozzles (not shown by the water/H₂O₂ flow ratio). A relatively small amount of diluent water was by-passed during the first half of the run in order that a high exhaust temperature could be maintained. The pyrometer giving the exhaust temperature indicated occasional surges. During the second half of the run, less diluent water was by-passed thus reducing the exhaust temperature and the possibility of plant trip-out during exhaust temperature surges.

The increase in CO₂ together with the rise in liner wall temperature readings, jacket water temperature readings, cooling water and diluent water temperature readings, in the first 36 minutes of operation on fuel indicated that the data of previous runs taken at shorter intervals after startup did not reflect the steady state operation of the system. Some of the liner and jacket water temperature readings did not settle out until later in the run. Many of the liner temperatures were above values that had been observed in previous runs when liner burning had resulted. Inspection of the liner after run 72-12B revealed that no burning had occurred. In addition the fuel nozzle was undamaged. The run was successful.

It was the opinion of the EES personnel and the Becco representative who had witnessed the final run that the run would have been equally successful at 750 psig chamber pressure. In run 67-12B which utilized the slotted ball baffle fuel nozzle, the liner wall temperatures recorded at 650 and then 750 psig showed an average increase of 24° for the 750 psig operation. Part of the increase is the normal rise for the system.

VI. Summary Discussion of Combustion Chamber Modifications - Project "Hill"

Changing the design of the head section of the combustion chamber liner from the conical shape utilized during the Alton project to the dome shape recommended by Becco did not eliminate burning of the top portion of the liner (Figures 1 and 7). The liner burning was attributed to liquid fuel reaching the liner wall and burning

C O N F I D E N T I A L

C O N F I D E N T I A L

there. Attempts to reduce the fuel spray penetration by reducing the fuel injection velocity gave improved operation but liner burning still occurred. The fuel injection velocity was decreased from 72.5 ft/sec. about 20 ft/sec. by increasing the number of holes in the fuel nozzle (Figures 3 and 12). A 24 hole fuel nozzle giving a conical spray pattern and an injection velocity of 30 ft/sec. gave the best test results. Decreasing the included fuel spray angle also proved to be unsuccessful in preventing liner burning.

The original combustion chamber incorporated an H_2O_2 decomposition gas swirl just above the fuel tip. Data taken during a test without combustion showed that the location of the highest liner temperatures was the same for the non-combustion and combustion runs. The gas swirl was causing increased heat transfer by reducing the thickness of the gas film at the liner wall. A combustion run with the gas swirl vanes removed gave poor performance (79.6% CO_2). The need of a turbulence producing device other than the gas swirl vanes was indicated.

"Coaxial" baffles, and "dual swirl" turbulence producers were unsuccessful (Figures 14, 15, 16, and 19). A ring baffle proposed by Becco (Figure 17) approached the desired results. No liner burning occurred but the combustion efficiency was low (CO_2 - 89.6%). Modifications were made to the ring baffle to give an optimum performance of about 95% CO_2 (Figures 18, 20, and 21).

High performance of the ring or "donut" baffle resulted in chamber liner burning at its lower edge where it was backed with packing as indicated on Figure 10. Drilling of the diluent spray nozzles was unsuccessful in preventing the damage to the bottom of the liner. The addition of a water spray ring at the critical section provided a somewhat make-shift solution. A central nozzle was partially evaluated (Figure 23) but return to the nozzle - spray ring arrangement was made because of limited project funds.

C O N F I D E N T I A L

C O N F I D E N T I A L

A liner wall temperature fluctuation noted during the high performance (95% CO₂) with the donut baffle was eliminated by adding slots to the baffle (Figure 25). The slotted donut baffle turbulence ring together with the conical fuel spray and diluent arrangement of 4 nozzles and the cooling ring gave high performance (average 97% CO₂) for a 2-1/2 hour run at 650 psig chamber pressure without any liner damage.

VII. Results of Combustion Tests Carried Out at Becco

In accordance with contract amendment No. 6 dated 29 February 1956, a brief H₂O₂-diesel fuel combustion study was conducted at Becco from the middle of May to the end of June 1956. The basic combustion arrangement of H₂O₂ externally decomposed and liquid diesel fuel injection employed at EES was retained with a 2-1/2" I.D. combustion chamber.

Flow rates of H₂O₂, fuel, and water to the 2-1/2" chamber were based on a combustion zone cross-section area ration to the modified Alton unit. Thus the heat release rate per in.² of liner area was approximately equal to that of the modified Alton chamber. The combustion chamber run at Becco had an effective combustion zone length of about 4 and later 5 inches taking the distance from the throat of the head to the point where the flame was quenched by diluent water. The effective length of the modified Alton chamber was about twenty inches.

The first five runs at Becco were a simulation of the combustion chamber arrangement that proved successful in test runs at EES (Figure 26). All subsequent tests incorporating changes to be described later, were compared to the simulated Alton arrangement. The changes made in the chamber configuration and fuel spray were an attempt to study configurations which might yield significant increases in performance over that attained in Runs 1 through 5 or at least to point out fruitful avenues of approach in future combustion chamber development work utilizing decomposed H₂O₂ and fuel. Emphasis was placed on evaluating as many configurations as possible

C O N F I D E N T I A L

C O N F I D E N T I A L

rather than gaining optimum performance for a few changes. Therefore, the test results are to be considered as preliminary only. A schematic diagram of the test system employed at Becco is shown in Figure 27.

Runs 1 through 4 were conducted for system check out and to familiarize operating personnel with test procedures.

Run No. 5 gave results for comparison with later runs, Table VII. All tests were of approximately 5 minutes duration and utilized diesel oil as fuel. Run No. 6 was made at increased flow rates and chamber pressure and indicated a slight decrease in CO₂ (82.3 vs. 81.6%) correlating with slight CO₂ decrease with increased pressure obtained during runs at EES. The fuel spray pattern for runs 5 and 6 is shown in Plate 1.

The first change in the combustion configuration was an attempt to reduce the size of fuel droplets. Both Arde Associates and the engineers at Becco favored the approach of reduction of fuel spray droplet size.⁽⁵⁾ A Monarch #70-80° hollow cone nozzle was used together with the flat baffle for Run No. 7 (Plate 2). CO₂ decreased from 82.3 to 75.4%. In runs 5, 6, and 7 operation was oxidant rich. Correction for the oxidant rich combustion was approximated by subtracting the volume of excess O₂ from the sample volume.

Run No. 8 was an attempt to increase the chamber performance by lowering the diluent nozzle to increase the effective combustion length from 4" to approximately 5 inches. No increase in CO₂ was noted. Combustion was fuel rich which accounted for the increased chamber pressure with lower CO₂.

(5) "Analysis of Combustion in the Alton Chamber" Dr. E. Mayer, B. J. Aleck, Arde Associates Report No. 2567-1.

C O N F I D E N T I A L

C O N F I D E N T I A L

For run No. 9 the fuel spray droplet size was further reduced by employing a #28-60° Monarch hollow spray nozzle (Plate 3). The percentage of CO₂ in the non-condensibles of the exhaust gases was lower than Run 7 which employed a #70-80° Monarch. Further reduction in droplet size was considered useless.

Runs 10 and 11 were to evaluate solid spray nozzles (Plates 4 and 5) and indicated an increase in CO₂ with decreased droplet size.

Run No. 12 incorporated a fuel nozzle configuration that had proved successful in previous test work at Becco. The arrangement utilized a bluff body type flame holder (Figure 28). The fuel tip was a #70-80° Monarch. A comparison of runs 7 and 12 indicates excellent operation with the flat flame holder.

Because flow patterns about a conical flame holder appeared to give more intense mixing⁽⁶⁾ a conical flame holder was installed for run No. 12 (Figure 29). Performance decreased.

The "straight through" head arrangement (Figure 30) for Run 14 was evaluated to explore the possibility of a simpler head design in comparison to the "restricted" entry used in the previous runs. Performance decreased. An interesting effect of the use of flame holders was noted. The straight through head insert had never been exposed to high temperatures before the run. After the run an inspection of the insert revealed only very slight discoloration of the metal. The flame holder stabilized the combustion in a manner that eliminated high heat transfer to the head section.

Runs 15 and 16 incorporated a rather drastic change over the general configuration tested at EES. The fuel tip was installed in the diluent spray nozzle giving "reverse flow" fuel injection (Figure 31). It was hoped that the stay time;

(6) "Some Experimental Techniques for the Investigation of the Mechanism of Flame Stabilization in the Wakes of Bluff Bodies" H. M. Nicholson, J. P. Field, LCdr, USN, Bureau of Ordnance, Contract NOrd 7386

C O N F I D E N T I A L

C O N F I D E N T I A L

i.e., the length of time each particle of fuel could burn before being quenched by the diluent water spray, would be greatly increased thus assuring efficient combustion. A baffle was installed just below the throat at the liner inlet to prevent any fuel from being sprayed into the uncooled chamber below the catalyst bed. The fuel sprays were checked before each run by removing the catalyst chamber and baffle at the head and observing the amount of fuel spray emitted through the throat of the head insert. Very little fuel was sprayed out of the chamber with the #70-80° Monarch at rated flow. Considerable spray was emitted when the #50-35° Monarch was installed. Runs 15 and 16 gave poor results. No difficulty was experienced with light off and chamber pressure remained steady.

The preliminary conclusions from the H_2O_2 decomposition liquid diesel fuel injection tests made at Becco are as follows:

- (a) Reduction of droplet size in a hollow cone spray by increasing the pressure drop across the fuel nozzle will not increase combustion efficiency.
- (b) Decreasing fuel droplet size with a solid spray increases combustion efficiency.
- (c) "Restricted entry", flat flame holder below the throat, will give good operation and reduce heat transfer at the head of the liner.
- (d) "Reversed flow" fuel injection as performed resulted in poor performance.
- (e) Removal of the restricted H_2O_2 decomposition gas entry passage decreases performance.
- (f) A flat flame holder gives better performance than a conical flame holder.

In addition to the combustion tests, flow tests were conducted with a plexiglass mockup of the combustion chamber. An attempt was made to obtain a picture

C O N F I D E N T I A L

C O N F I D E N T I A L

of a 2 dimensional flow pattern within a 3 dimensional flow (Figure 32). Nitrogen and entrained aluminum particles passed through the mockup. Difficulties experienced fabricating the plexiglass and obtaining satisfactory pictures within the short test period (Plate 6) prevented the possible use of the flow pattern pictures in the selection of test set-ups that would give better performance. The degree of correlation between the intensity and geometry of turbulence obtained with the plastic chamber and the performance of the stainless steel combustion chamber would have determined the usefulness of the plastic mockup. More development work is required before adequate flow pattern pictures can be obtained with a 3 dimensional mockup of a combustion chamber under consideration.

The shortness of the test program prevented experimentation with other types of fuels. An analytical description of combustion prepared by Arde Associates⁽⁷⁾ for Becco predicted a gain in combustion efficiency when more volatile fuels than diesel oil are burned in a given short combustion chamber.

A summary of the analytical description of combustion is presented in Appendix A.

VIII. Conclusions and Recommendations

Full power operation of the H₂O₂-diesel fuel Alton combustion chamber called for maintaining 750 psig chamber pressure and 1300°F exhaust continuously for ten hours with a minimum of 90% CO₂ by volume in the non-condensibles of the exhaust. The combustion chamber developed during Project "Hill" demonstrated near full power operation for 2-1/2 hours with an exhaust temperature at an average of approximately 1200°F in run 72-12B. The CO₂ of the exhaust during the 2-1/2 hour run was well above the minimum of 90% and the combustion chamber liner burning that

(7) loc. cit. Arde Associates No. 2567-1

C O N F I D E N T I A L

occurred during full power operation of the Alton system was eliminated. It is Becco's opinion that the combustion chamber configuration test was employed in run 72-12B could operate successfully at full power for ten hours. As mentioned earlier, the final run configuration was operated at 750 psig chamber pressure for a short time in run 67-12B without causing any liner damage. In addition, if 90% H_2O_2 of slightly greater purity than that on hand at EES were employed in a 10 hour test, a samarium treated silver screen catalyst bed could be expected to provide satisfactory decomposition for the duration of the test. The catalyst difficulties experienced half way through the Project "Hill" test program prompt the previous statement.

The following modifications might prove to further increase the reliability and/or simplicity of the Project "Hill" chamber:

- (a) Substitution of a properly located central spray diluent nozzle fed from four plain pipes for the cooling ring, four nozzle diluent arrangement.
- (b) Installation of a $3/4$ " pipe spray ring in place of the $3/8$ " cooling ring and removal of the four spray nozzles. The larger ring would be drilled to provide a spray against the bottom of the liner to accomplish the affect of the cooling ring addition. The larger ring could also be drilled to provide a cone of flame quenching diluent water in the bottom of the combustion space.
- (c) Removal of the slotted ring baffle from the fuel tip, increasing the fuel tip length, and the addition of a $1/2$ " diameter flat flame holder to give a configuration similar to the flat flame holder - restricted entry arrangement that showed promise during the tests at Becco of maintaining high combustion efficiency while eliminating the cooling problems in the head section.

C O N F I D E N T I A L

C O N F I D E N T I A L

Additional combustion studies could be made at Becco in order to reduce the development time required for the proper operation of a H_2O_2 supported combustion system. The information obtained may also contribute in a small way to the better understanding of the whole field of turbulent, high pressure combustion. Development work with H_2O_2 decomposition gases to which a swirl is imparted as was done with the swirl vanes on the fuel inlet of the Alton chamber and with the Arde dual swirl nozzle tested during Project "Hill" could be continued. Such general combustion configurations using air can give high heat release rates while maintaining relatively cooling combustion chamber walls. (8) Reverse flow fuel injection could also be investigated further. Such an arrangement should provide the intense mixing that efficient combustion requires. In fact, the configuration run at Becco probably provided too intense mixing. It appeared that the turbulence inside the chamber during combustion caused a blow out of the burning of the heavier fuel fractions and consequently poor combustion.

More volatile fuels than diesel oil may prove to be more easily adaptable to an H_2O_2 supported combustion chamber. The relations developed in the Arde Report summarized in Appendix A, indicate that more volatile fuels would give more trouble-free operation.

More exact design parameters could be developed for the restricted-entry flat flame holder arrangement.

Finally, an approach to the problem of the development criteria for successful chamber design was only begun in the test work at Becco described earlier in this report. The possibility of proving the existence of a correlation between the geometry and intensity of turbulence obtained by photography of a non-combustion

(8) "Flame Stabilization in Gases Flowing Cyclonically Flow Characteristics, Temperatures and Gas Analysis" L.F. Albright, L.G. Alexander, University of Oklahoma

C O N F I D E N T I A L

C O N F I D E N T I A L

plastic chamber mockup and the combustion efficiency obtained in the steel counterpart appears attractive. If such a correlation exists, considerable development work could be done with inexpensive fluids (nitrogen and aluminum particles). This general approach could be carried one step further if the first phases described above are successful. Glass wall combustion chambers together with Schlieren photography and flame ionic probes could then be used to more fully describe the actual flame. The existence of a correlation between the plastic mockup flow patterns and the local conditions of temperature, velocity, and degree of reaction obtained by Schlieren photography and ionic probes would give useful data to the entire field of turbulent combustion research. The effects of flame generated turbulence would be the least that would be obtained.

C O N F I D E N T I A L

C O N F I D E N T I A L

TABLE I

TEST DATA RUN #68 MODIFIED CC-12 COMBUSTION CHAMBER

| | |
|--|-----------------|
| Date | 18 January 1953 |
| Combustion Chamber Pressure | 728 psig |
| Water/H ₂ O ₂ ratio in gals. | 2.00 |
| Fuel/H ₂ O ₂ ratio in gals. | .210 |
| Catalyst Chamber Disch. Temp. | 1255°F |
| Comb. Chamber Disch. Temp. | 1200°F |
| Cooling water to comb. ch. Temp. | 111°F |
| Diluent to spray nozzles temp. | 304°F |
| Diluent to comb. ch., pressure | 800 psig |
| Δ P across diluent spray nozzles | 72 psi |
| Fuel to comb. ch. pressure | 775 psig |
| Δ P fuel injector | 47 psi |
| Time on fuel | 5 minutes |
| Total flow | 52,682 #/hr. |

C O N F I D E N T I A L

C O N F I D E N T I A L

TABLE II

INSTRUMENTATION AT EES

| Fluid or Material | Location | Pressure | | Temperature | |
|---|--|----------|----------|-------------|----------|
| | | Gage | Recorder | Gage | Recorder |
| H ₂ O ₂ decomposition gases | catalyst chamber discharge | ✓ | | ✓ | ✓ |
| Exhaust gases from comb. chamber | steam separator | ✓ | ✓ | ✓ | ✓ |
| " | exhaust line loop | | ✓ | ✓ | ✓ |
| " | after orifice | | | ✓ | ✓ |
| " | to desuperheater | ✓ | | | |
| " | to condenser | ✓ | | ✓ | ✓ |
| Water | booster pump disch. | ✓ | | | |
| " | triple feed pump suction | ✓ | | | |
| " | triple feed pump discharge | ✓ | ✓ | | ✓ |
| " | proportioning device outlet | ✓ | | | |
| " | to combustion chamber cooling passages | | | | ✓ |
| " | to catalyst chamber cooling passages | ✓ | | ✓ | ✓ |
| " | to diluent nozzles | ✓ | ✓ | | ✓ |
| " | from cooler | | | | ✓ |
| " | to desuperheater | ✓ | | ✓ | ✓ |
| " | combustion chamber cooling jacket* | | | | ✓ |
| Seawater | to condenser | ✓ | | ✓ | |
| H ₂ O ₂ | booster pump disch. | ✓ | | | |
| " | triple feed pump disch. | ✓ | | | ✓ |
| " | after throttle valve | ✓ | | | |
| Fuel | booster pump disch. | ✓ | | | |

C O N F I D E N T I A L

TABLE II (contd.)

| Fluid or Material | Location | Pressure | | Temperature | |
|-----------------------------|---|----------|----------|-------------|----------|
| | | Gage | Recorder | Gage | Recorder |
| Fuel | triple feed pump suct. | ✓ | | | |
| " | triple feed pump disch. | ✓ | ✓ | | ✓ |
| " | proportioning device outlet | ✓ | | | |
| " | to combustion chamber (after solenoid valve) | ✓ | | | |
| Steam | Condenser shell | ✓ | | ✓ | ✓ |
| Control air | after solenoid valve | ✓ | | | |
| Lube oil | to triple feed pump | ✓ | | | ✓ |
| " " | from triple feed pump | ✓ | | | ✓ |
| Triple feed pump | 3-upper sleeve bearings | | | | ✓ |
| " " " | 3-lower sleeve bearings | | | | ✓ |
| " " " | 3 - ball bearings | | | | ✓ |
| " " " | housing | | | | ✓ |
| Combustion chamber liner | thermocouple wires peened into wall * | | | | 28 ✓ |

* located as per dwg. SP 859-R2

C O N F I D E N T I A L

TABLE III

RUN 5-12B SUMMARY DATA

| Date: | 17 February 1955 | Wall and Jacket Temps. | °F |
|--|------------------|------------------------|-----|
| Combustion Chamber Press. | 650 psig | Liner wall temp., dome | |
| CO ₂ | 97.9% | W 1 | - |
| O ₂ | 1.71% | W 1A | - |
| CO | .13% | W 2 | 352 |
| H ₂ | .21% | W 3 | 361 |
| Water/H ₂ O ₂ ratio, gpm | 1.96% | W 3A | - |
| Fuel/H ₂ O ₂ ratio, gpm | .206 | W 4 | 230 |
| Cat. chamber discharge temp. | 1320°F | 3-1/8" from throat | |
| Comb. " " (Sep.) temp. | 1180°F | W 5 | 425 |
| " " " (loop) temp. | 1160°F | W 6 | 534 |
| Cooling water to comb. ch. temp. | 68°F | W 7 | 509 |
| " " " " temp. | 192°F | W 8 | 495 |
| | | W 9 | 356 |
| Diluent to spray nozzles, temp. | 198°F | W 10 | 660 |
| | | W 11 | 500 |
| Recirculating pump | On | 4-1/8" from throat | |
| H ₂ O ₂ after throttle valve, press. | 700 psig | W 13 | 483 |
| Diluent to comb. chamber, press. | 700 psig | W 14 | 765 |
| | | W 15 | 665 |
| Fuel to comb. chamber, press. | 670 psig | W 16 | 400 |
| | | 4-15/16" from throat | |
| Time on H ₂ O ₂ | 46 #min. 30 sec. | W 17 | - |
| | | W 18 | 682 |
| Time on Fuel | 37 " 55 | W 19 | 330 |
| | | W 20 | 933 |
| | | 5-11/16" from throat | |
| | | W 21 | 218 |
| | | W 22 | 734 |
| | | W 23 | - |
| | | W 24 | 752 |
| | | 10-1/8" from throat | |
| | | W 25 | - |
| | | W 26 | 199 |
| | | Jacket Water, dome | |
| | | J 1 | 158 |
| | | J 2 | 244 |
| | | 3-1/8" from throat | |
| | | J 3 | 143 |
| | | J 4 | 157 |
| | | 5-11/16 from throat | |
| | | J 5 | - |
| | | J 6 | 140 |
| | | 10-1/8" " " | |
| | | J 7 | 121 |
| | | J 8 | 114 |
| | | 18-1/8" " " | |
| | | J 9 | 111 |
| | | J 10 | 94 |

C O N F I D E N T I A L

C O N F I D E N T I A L

TABLE IV

RUN 62-12B

DATA BEFORE AND AFTER TEMPERATURE CHANGES

| | Before | After | | | | | |
|---------------------------------|--------|-------|----------------------|---------------------|------|-----|-----|
| CO ₂ | 95.1 | 93.3 | 5-11/16" from throat | W22 | 375 | 213 | |
| Cooling water to comb. ch. °F | 60 | 65 | | W23 | 220 | 167 | |
| | | | | W24 | 211 | 168 | |
| Cooling water from comb. ch. °F | 204 | 160 | 10-1/8" from throat | W25 | 300 | 310 | |
| Diluent to nozzles °F | 215 | 175 | | W26 | 340 | 197 | |
| Recirculating pump | Off | Off | 18-1/8" from throat | W27 | 280 | 126 | |
| Wall readings dome | W 1A | 298 | | W28 | 127 | 228 | |
| | ↓ | W 2 | | Jacket water, Dome | J 1 | 189 | 153 |
| | | W 3A | | " " " | J 2 | 184 | 154 |
| | | W 4 | | 3-1/8" from throat | J 3 | 175 | 150 |
| 3-1/8" from throat | W 5 | 317 | | " " " | J 4 | 185 | 154 |
| | ↓ | W 6 | | 10-1/8" from throat | J 7 | 146 | 148 |
| | | W 7 | | " " " | J 8 | 144 | 147 |
| | | W 8 | | 18-1/8" from throat | J 9 | 101 | 122 |
| | | W 9 | | " " " | J 10 | 102 | 100 |
| | | W 10 | | | | | |
| | | W 11 | | | | | |
| 4-1/8" from throat | W 14 | 220 | | | | | |
| | ↓ | W 15 | | | | | |
| 4-15/16" from throat | W 18 | 250 | | | | | |
| | ↓ | W 19 | | | | | |
| | | W 20 | | | | | |

C O N F I D E N T I A L

TABLE V

DATA SUMMARY RUNS 71 AND 72-12B

| RUN NUMBER | 71-12B | | 72-12B | | | | | | | | | |
|---|------------|-------|------------|-------|-------|-------|-------|-------|----------------|---------|-------|-------|
| | 3 May 1956 | | 7 May 1956 | | | | | | | | | |
| Date 1955 - 1956 | PSIG | 660 | 660 | 670 | 655 | 650 | 650 | 640 | 645 | 645 | 665 | 685 |
| Comb. Ch. Pressure cont. recorder | % | 94.5 | 95.2 | - | 97.3 | - | 98.2 | - | - | - | 97.2 | 97.9 |
| CO ₂ | % | 3.01 | 3.26 | - | - | - | 1.42 | - | - | - | 1.25 | - |
| O ₂ | % | .66 | .41 | - | - | - | .13 | - | - | - | .52 | - |
| CO | % | 1.74 | 1.06 | - | - | - | .23 | - | - | - | 1.00 | - |
| H ₂ | % | 1.94 | 1.95 | 1.93 | 1.92 | 1.95 | 1.92 | 1.93 | 1.93 | 1.93 | 1.94 | 1.93 |
| Water/H ₂ O ₂ Ratio | - | .206 | .206 | .206 | .206 | .210 | .206 | .206 | .206 | .206 | .207 | .206 |
| Fuel/H ₂ O ₂ Ratio | F | 1320 | 1330 | 1320 | 1320 | 1320 | 1330 | 1320 | 1330 | 1330 | 1330 | 1320 |
| Cat. Ch. Discharge | F | 1160 | 1160 | 1320 | 1330 | 1340 | 1330 | 1340 | 1280 | 1280 | 1270 | 1240 |
| Comb. Ch. Disch. (Sep) | F | 1040 | 1120 | 1260 | 1270 | 1280 | 1220 | 1220 | 1230 | 1220 | 1220 | 1220 |
| " " " (Loop) | F | | 1035 | 1160 | 1190 | 1190 | 1130 | 1140 | 1150 | 1125 | 1135 | 1140 |
| Gas Temp. after orifice | F | 640 | 582 | 915 | 1031 | 1105 | 1120 | 1140 | 1155 | 1154 | 1160 | 1168 |
| Cool water to comb. ch. | F | 69 | 68 | 115 | 124 | 125 | 126 | 125 | 125 | 125 | 122 | 127 |
| " " from " | F | 226 | 218 | 260 | 280 | 278 | 280 | 271 | 280 | 282 | 276 | 267 |
| Diluent to comb. ch. | F | 239 | 232 | 276 | 293 | 291 | 292 | 288 | 294 | 294 | 290 | 282 |
| Recirculating Pump | - | OFF | OFF | | | | | | | | | |
| H ₂ O ₂ after throttle v. | PSIG | 820 | 800 | 810 | 810 | 810 | 810 | 810 | 820 | 830 | 870 | 900 |
| Diluent to comb. ch. | PSIG | 700 | 680 | 690 | 680 | 675 | 675 | 670 | 680 | 680 | 675 | 725 |
| 4 P across Diluent noz. | PSIG | 40 | 20 | 20 | 25 | 25 | 25 | 30 | 35 | 35 | 30 | 45 |
| Fuel to comb. ch. | PSIG | 680 | 670 | 680 | 670 | 665 | 660 | 650 | 665 | 665 | 665 | 710 |
| 4 P across fuel noz. | PSIG | 20 | 10 | 10 | 15 | 15 | 10 | 10 | 20 | 20 | 20 | 25 |
| Time on H ₂ O ₂ - min. - sec. | - | 15-20 | | | | | | | 2 hrs. 40 min. | 5 sec. | | |
| Time on fuel - min. - sec. | - | 13-50 | | | | | | | 2 hrs. 37 min. | 45 sec. | | |
| Thermocouple code | | 15 | 15 | 15 | 15 | 15 | 15 | 15 | 15 | 15 | 15 | 15 |
| Press. drop across fuel nozzle.decomp. gas | PSIG | 20 | 15 | 10 | 20 | 20 | 15 | 20 | 25 | 25 | 35 | 25 |
| Reading time (on fuel ll.:ll.) | | | 11:16 | 11:31 | 11:46 | 12:01 | 12:16 | 12:31 | 12:46 | 13:01 | 13:16 | 13:46 |
| Wall temp. dome W 1A | F | 595 | 536 | 568 | 600 | 612 | 625 | 628 | 635 | 650 | 658 | 654 |
| " " " W 2 | | 335 | 345 | 388 | 370 | 369 | 365 | 350 | 370 | 362 | 382 | 382 |
| " " " W 3 | | - | - | - | - | - | - | - | - | - | - | - |
| " " " W 3A | | 470 | 465 | 525 | 535 | 540 | 535 | 535 | 550 | 540 | 548 | 542 |
| " " " W 4 | | 260 | 250 | 285 | 295 | 290 | 288 | 280 | 295 | 295 | 365 | 302 |

71
-12B

72-12B

| | | 7 May 1956 | | | | | | | | | | | | | | | | |
|----------------------|------|------------|-----|-------|-----|-------|-----|-------|-----|-------|-----|-------|-----|-------|-----|-------|-----|-----|
| RUN NUMBER | Date | 3 May | | 3 May | | 3 May | | 3 May | | 3 May | | 3 May | | 3 May | | 3 May | | |
| | | | 462 | 467 | 370 | 413 | 413 | 436 | 383 | 435 | 410 | 593 | 662 | 370 | 605 | 615 | 470 | 470 |
| 3-1/8" from throat | W5 | 363 | 437 | 450 | 445 | 445 | 445 | 462 | 460 | 469 | 480 | 479 | 465 | | | | | |
| | W6 | 400 | 438 | 645 | 650 | 710 | 768 | 750 | 795 | 795 | 775 | 790 | 728 | | | | | |
| | W7 | 404 | 413 | 450 | 460 | 450 | 460 | 460 | 455 | 455 | 450 | 440 | 458 | | | | | |
| | W8 | - | - | - | - | - | - | - | - | - | - | - | - | | | | | |
| | W9 | 404 | 436 | 462 | 472 | 463 | 408 | 460 | 452 | 452 | 440 | 448 | 430 | | | | | |
| | W 10 | 345 | 383 | 365 | 380 | 385 | 398 | 405 | 400 | 400 | 390 | 390 | 400 | | | | | |
| | W 11 | - | - | - | - | - | - | - | - | - | - | - | - | | | | | |
| | W 12 | 395 | 435 | 460 | 470 | 470 | 480 | 450 | 440 | 440 | 450 | 480 | 467 | | | | | |
| 4-1/8" from throat | W 13 | - | - | - | - | - | - | - | - | - | - | - | - | | | | | |
| | W 14 | 385 | 410 | 420 | 420 | 415 | 408 | 425 | 410 | 410 | 415 | 420 | 425 | | | | | |
| | W 15 | - | - | - | - | - | - | - | - | - | - | - | - | | | | | |
| | W 16 | 495 | 593 | 610 | 628 | 620 | 614 | 615 | 593 | 593 | 577 | 600 | 605 | | | | | |
| 4-15/16" from throat | W 17 | 615 | 662 | 705 | 674 | 575 | 522 | 685 | 553 | 553 | 535 | 530 | 475 | | | | | |
| | W 18 | 330 | 370 | 375 | 390 | 380 | 390 | 405 | 403 | 403 | 410 | 400 | 338 | | | | | |
| | W 19 | - | - | - | - | - | - | - | - | - | - | - | - | | | | | |
| | W 20 | 450 | 605 | 643 | 630 | 678 | 653 | 610 | 565 | 565 | 560 | 552 | 612 | | | | | |
| 5-1/16" from throat | W 21 | 290 | 315 | 380 | 390 | 360 | 410 | 405 | 420 | 420 | 430 | 425 | 394 | | | | | |
| | W 22 | 285 | 315 | 328 | 335 | 330 | 322 | 338 | 330 | 330 | 328 | 315 | 305 | | | | | |
| | W 23 | - | - | - | - | - | - | - | - | - | - | - | - | | | | | |
| | W 24 | - | - | - | - | - | - | - | - | - | - | - | - | | | | | |
| 10-1/8" " | W 25 | 290 | 295 | 315 | 313 | 310 | 380 | 290 | 230 | 230 | 250 | 245 | 282 | | | | | |
| | W 26 | 245 | 290 | 335 | 342 | 320 | 323 | 320 | 330 | 330 | 355 | 356 | 358 | | | | | |
| 18-1/8" from throat | W 27 | 253 | 375 | 300 | 230 | 240 | 215 | 232 | 231 | 231 | 225 | 223 | 210 | | | | | |
| | W 28 | 160 | 192 | 208 | 200 | 190 | 305 | 195 | 195 | 195 | 210 | 190 | 182 | | | | | |
| Jacket water dome | J 1 | 207 | 249 | 264 | 260 | 262 | 258 | 261 | 260 | 260 | 258 | 253 | 252 | | | | | |
| | J 2 | 200 | 247 | 262 | 260 | 260 | 258 | 262 | 262 | 262 | 261 | 255 | 254 | | | | | |
| 3-1/8" from throat | J 3 | 191 | 238 | 254 | 254 | 253 | 250 | 255 | 256 | 256 | 251 | 248 | 243 | | | | | |
| | J 4 | 201 | 248 | 262 | 266 | 262 | 256 | 260 | 260 | 260 | 254 | 252 | 250 | | | | | |
| 5-11/16" from throat | J 5 | - | - | - | - | - | - | - | - | - | - | - | - | | | | | |
| | J 6 | - | - | - | - | - | - | - | - | - | - | - | - | | | | | |
| 10-1/8" from throat | J 7 | 154 | 200 | 213 | 215 | 213 | 211 | 216 | 215 | 215 | 209 | 209 | 207 | | | | | |
| | J 8 | 144 | 195 | 205 | 203 | 206 | 205 | 208 | 209 | 209 | 205 | 201 | 200 | | | | | |
| 18-1/8" from throat | J 9 | 104 | 157 | 164 | 164 | 165 | 172 | 170 | 169 | 169 | 158 | 159 | 154 | | | | | |
| | J 10 | 111 | 155 | 168 | 168 | 168 | 157 | 167 | 167 | 167 | 166 | 166 | 166 | | | | | |

C O N F I D E N T I A L

TABLE VI

VARIOUS SYSTEM PRESSURES ADDITIONAL DATA - RUN 72-12B

| Comb. Ch Disch. Con- tinuous rec- order (Sep) | Time | Fuel Booster Before Filter | Water Booster Before Filter | Peroxide Booster Discharge | Peroxide TFP Discharge | Comb. Ch. Dis- charge | Fuel Prop. In. | Fuel Prop. Out | Water Prop. In | Water Prop. Out | Cat. Ch. Dis- charge | Steam to Con- denser | Diluent Fuel Water to Comb. Chamber | Fuel to Comb. Chamber | Triple Feed Pump |
|--|------|-------------------------------------|--------------------------------------|----------------------------------|------------------------------|--------------------------------|----------------------|----------------------|----------------------|-----------------------|-------------------------------|-------------------------------|--|--------------------------------|------------------------|
| | | PSI | PSI | PSI | PSI | PSI | PSI | PSI | PSI | PSI | PSI | PSI | PSI | PSI | PSI |
| 660 | 1116 | 50 | 43 | 41 | 860 | 650 | 830 | 720 | 850 | 650 | 675 | 22.5 | 680 | 670 | 4020 |
| 670 | 1131 | 54 | 48 | 52 | 820 | 660 | 800 | 740 | 830 | 650 | 680 | 23.0 | 690 | 680 | 3940 |
| 655 | 1146 | 54 | 48 | 45 | 820 | 650 | 800 | 730 | 840 | 650 | 675 | 22.0 | 680 | 670 | 3940 |
| 650 | 1201 | 54 | 49 | 46 | 815 | 650 | 800 | 720 | 840 | 650 | 670 | 21.5 | 675 | 665 | 3930 |
| 655 | 1216 | 51 | 49 | 46 | 815 | 650 | 800 | 710 | 840 | 650 | 665 | 21.5 | 675 | 660 | 3910 |
| 640 | 1231 | 55 | 50 | 46 | 815 | 640 | 800 | 740 | 850 | 650 | 660 | 21.5 | 670 | 650 | 3900 |
| 645 | 1246 | 56 | 51 | 47 | 810 | 650 | 800 | 720 | 840 | 650 | 670 | 21.5 | 680 | 665 | 3920 |
| 655 | 1301 | 56 | 51 | 47 | 815 | 645 | 800 | 720 | 840 | 650 | 670 | 21.5 | 680 | 667 | 3920 |
| 645 | 1316 | 56 | 51 | 47 | 815 | 640 | 800 | 715 | 840 | 650 | 670 | 21.5 | 675 | 665 | 3920 |
| 665 | 1331 | 56 | 51 | 54 | 850 | 630 | 830 | 750 | 870 | 750 | 700 | 22.5 | 710 | 690 | 4000 |
| 685 | 1346 | 56 | 50 | 51 | 880 | 625 | 860 | 765 | 890 | 770 | 710 | 23.5 | 725 | 700 | 4100 |

C O N F I D E N T I A L

CONFIDENTIAL

TABLE VII

TEST RESULTS - 90% H₂O₂ DECOMPOSITION DIESEL FUEL COMBUSTION AT BECCO

| RUN NO. | CONFIGURATION | FLOW RATE #/MIN. H ₂ O ₂ FUEL | AV. CH. PRESS. AND FLUCTUATIONS | AV. EXHAUST TEMP. | CO ₂ % | REMARKS |
|---------|--|---|---------------------------------|-------------------|-------------------|---|
| 5 | Nozzle No. 1 ring baffle restricted entry | 16.11 | 450 ± 0 | 950 | 82.3 | Corrected for oxidant rich operation |
| 6 | " " " " | 21.18 | 590 ± 50 | 750 | 81.6 | " " " " |
| 7 | #70-80° Monarch ring baffle restricted entry | 16.11 | 450 ± 15 | 850 | 75.4 | " " " " |
| 8 | Same as 7 increased effective combustion length to 10.5 | 16.44 | 470 ± 5 | 925 | 73.60 | Fuel rich operation |
| 9 | " " " " | 21.90 | 640 ± 40 | 950 | 64.2 | " " " " |
| 9 | #28-60° Monarch ring baffle restricted entry | 16.32 | 480 ± 10 | 950 | 72.6 | " " " " |
| 10 | No. 5 Monarch solid spray + ring baffle restricted entry | 16.32 | 420 ± 5 | 450 | 46.6 | Very rough operation at the end of the run |
| 11 | No. 3.5 Monarch solid spray - ring baffle - restricted entry | 16.32 | 455 ± 20 | 920 | 76.6 | " " " " |
| 12 | #70-80° Monarch restricted entry - flat flame holder | 16.32 | 465 ± 0 | 950 | 76.3 | " " " " |
| 13 | #70-80° Monarch restricted entry - conical flame holder | 16.32 | 450 ± 3 | 900 | 65.2 | " " " " |
| 14 | #70-80° Monarch straight through heat flat flame holder | 16.32 | 430 ± 0 | 850 | 56.2 | Only slight heat discoloration of head insert |
| 15 | Reverse flow #70-80° Monarch | 16.32 | 400 ± 5 | 430 | 36.4 | No burning or discoloration of baffle at head |
| 16 | Reverse flow #50-35° Monarch | 16.32 | 375 ± 2 | 450 | < 36.4 | " " " " |

C O N F I D E N T I A L

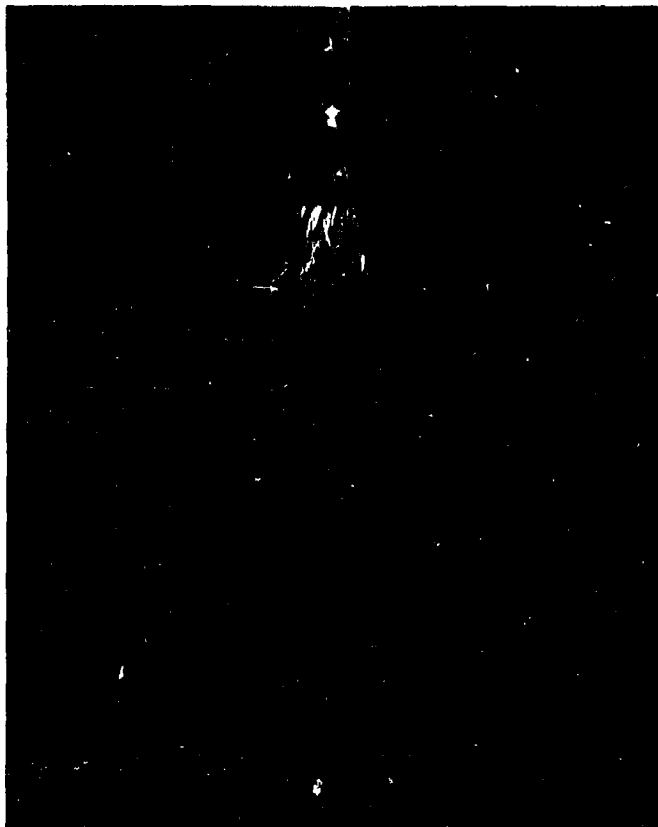

PLATE NO. 1

FUEL SPRAY PATTERN USED IN RUNS NO. 1-6 AT BECCO

DO NOT BAFFLE ATTACHED

C O N F I D E N T I A L

C O N F I D E N T I A L

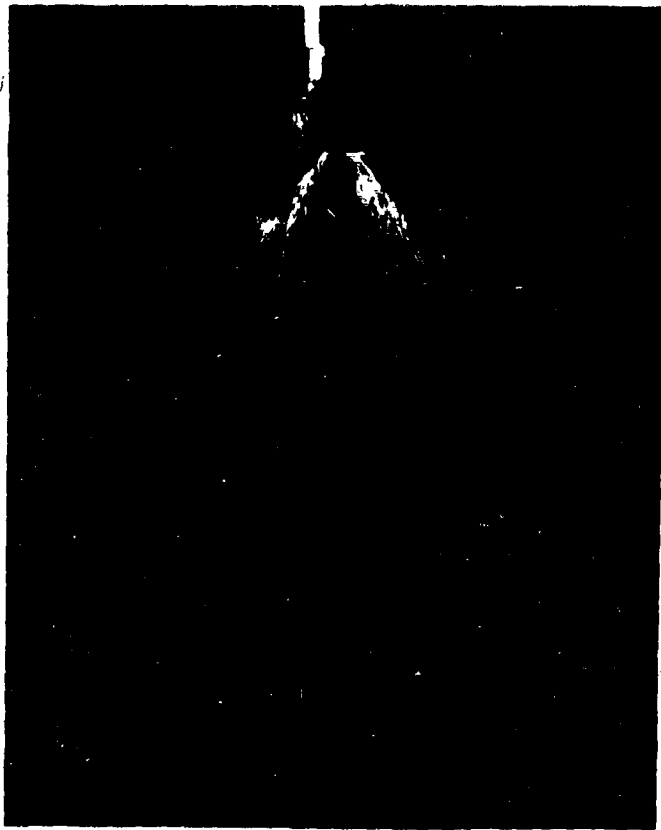

PLATE NO. 2

FUEL SPRAY PATTERN #70-80° MONARCH HOLLOW CONE USED IN

RUNS NO. 7 AND 8 AT BECCO

C O N F I D E N T I A L

C O N F I D E N T I A L

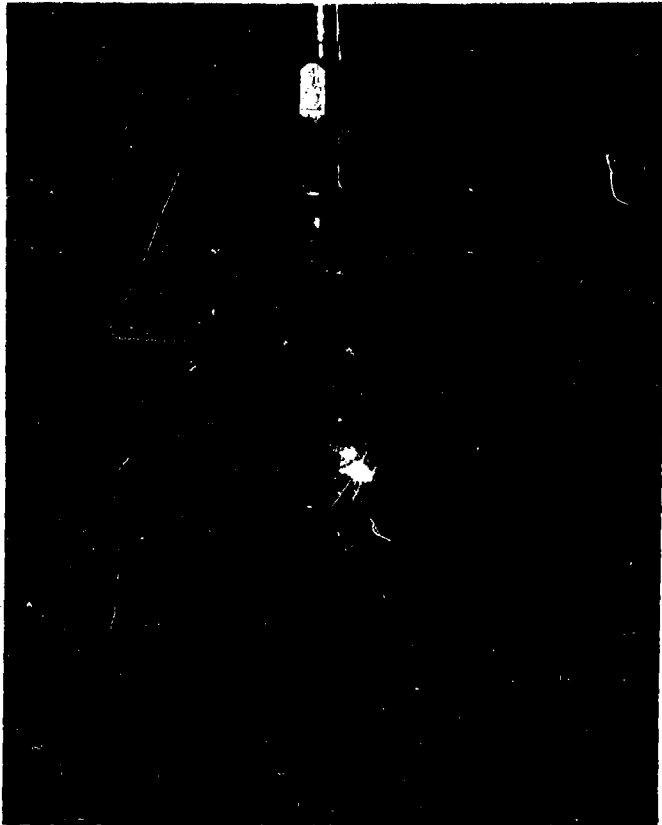

PLATE NO. 3

FUEL SPRAY PATTERN #28-60° MONARCH HOLLOW CONE USED IN

RUN NO. 9 BECCO TESTS

C O N F I D E N T I A L

C O N F I D E N T I A L

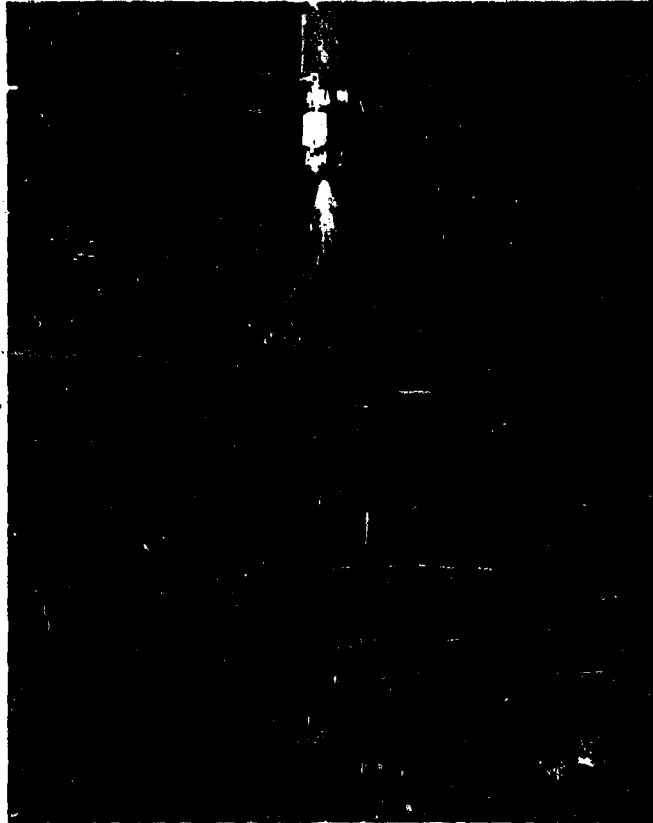

PLATE NO. 4

FUEL SPRAY PATTERN SOLID CONE RUN NO. 10

SPRAYING SYSTEMS NO. 5

C O N F I D E N T I A L

C O N F I D E N T I A L

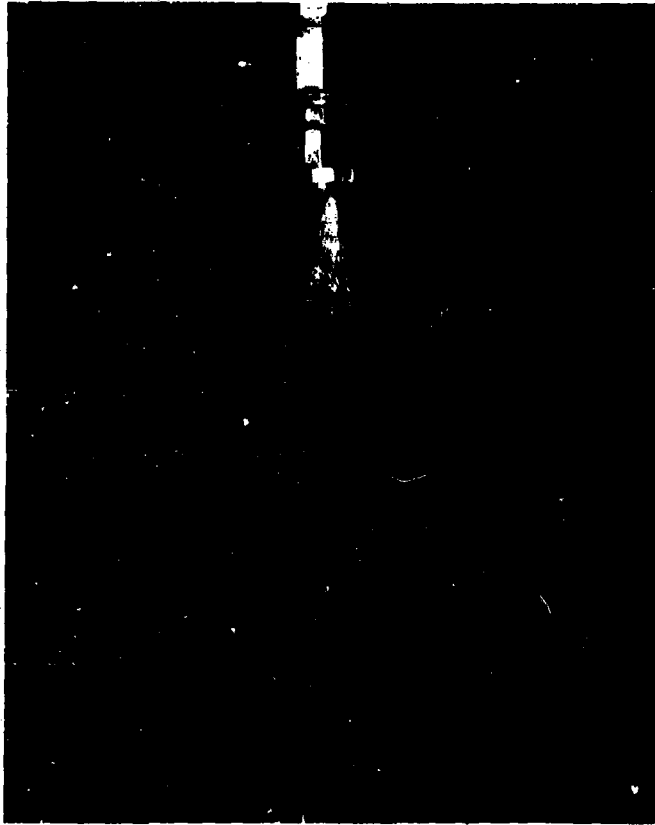

PLATE NO. 5

FUEL SPRAY PATTERN SOLID CONE RUN NO. 11

SPRAYING SYSTEMS NO. 3.5

C O N F I D E N T I A L

C O N F I D E N T I A L



PLATE NO. 6

NITROGEN AND ALUMINUM POWDER FLOW PATTERN THROUGH PLASTIC

MOCKUP WITH RING BAFFLE INSTALLED

C O N F I D E N T I A L

FOR THE DESIGN OF THE
COMBUSTION CHAMBER
AND THE VALVE
MECHANISM
AND THE
MECHANICAL
PARTS
AND THE
MECHANICAL
PARTS

CONFIDENTIAL

SCALE: 1/2" = 1"

CONFIDENTIAL

NOTE:
FOR THE DESIGN OF THE
COMBUSTION CHAMBER
AND THE VALVE
MECHANISM
AND THE
MECHANICAL
PARTS

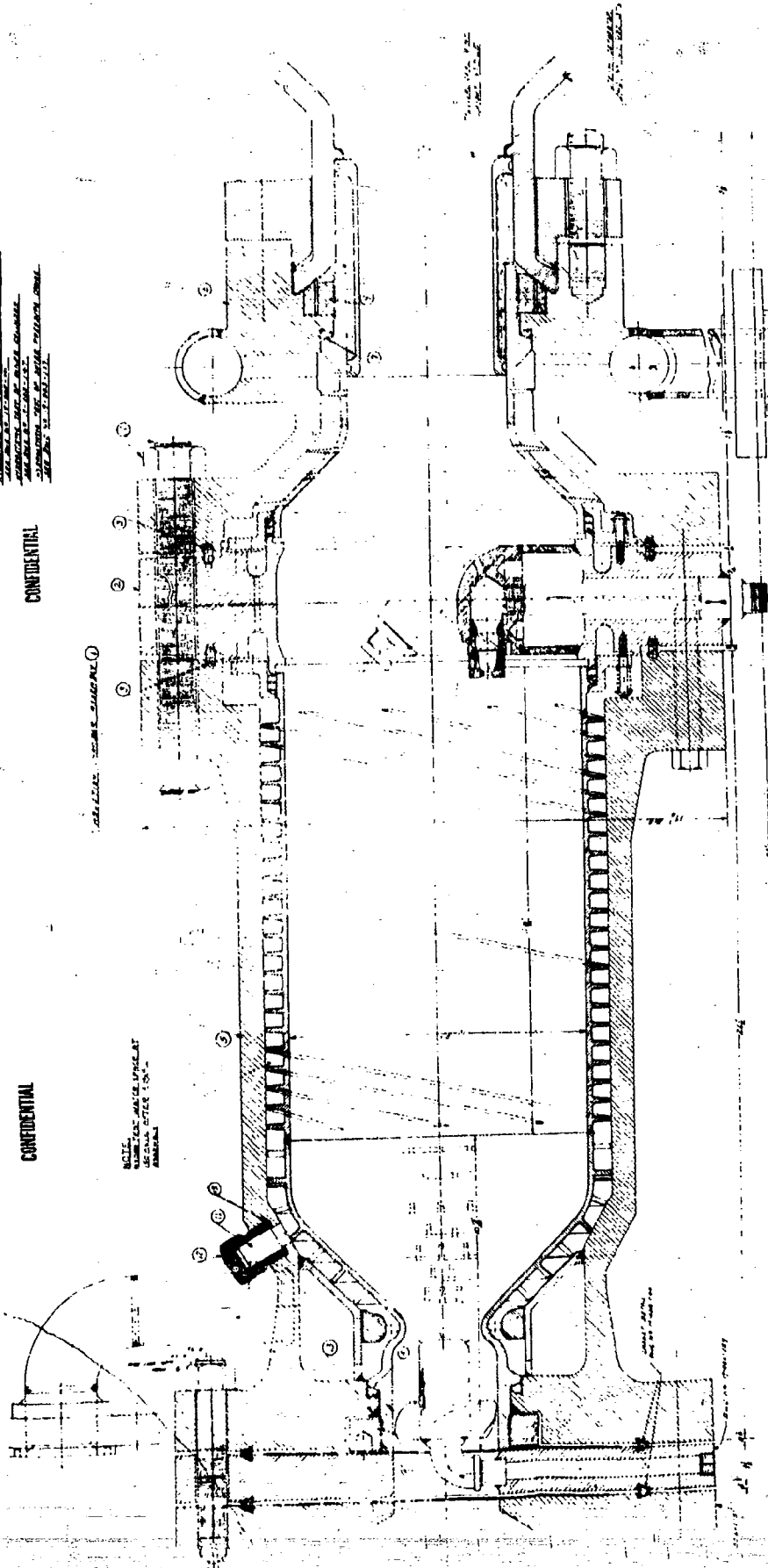

ALLIS CHALMERS 10 x 16 COMBUSTION CHAMBER

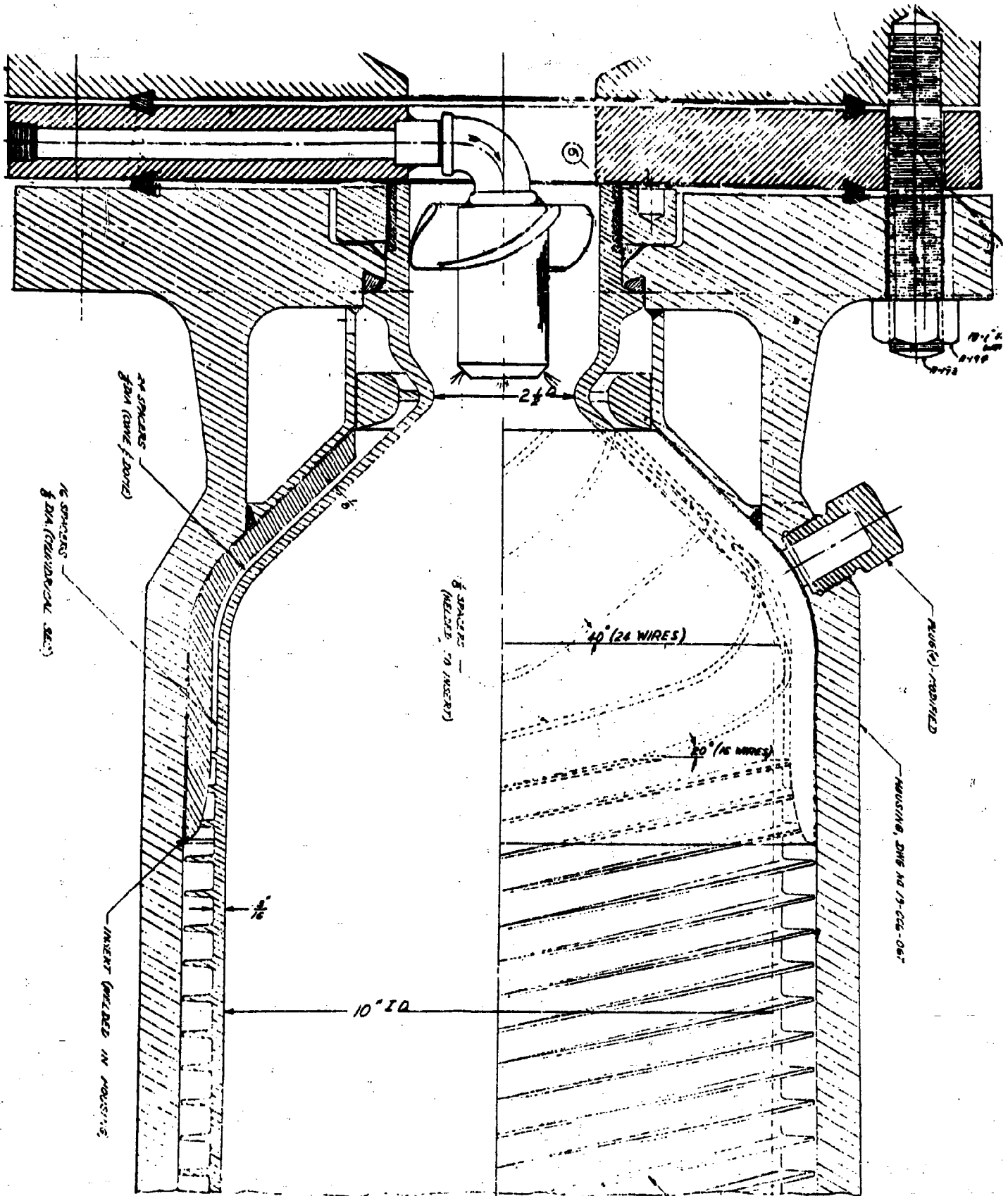

MODIFIED LINER IN ALLIS CHALMERS 10 x 16 COMBUSTION CHAMBER (CC-12 CHAMBER.)

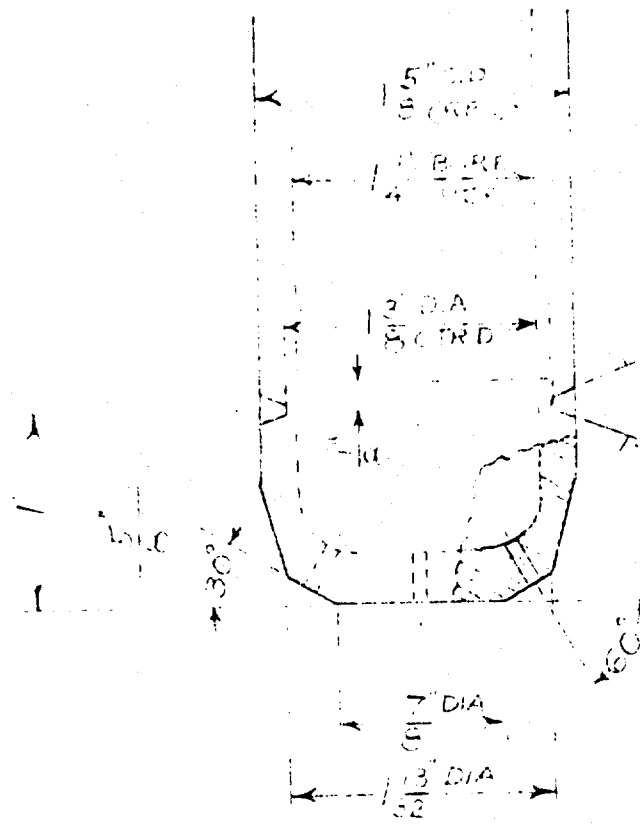

1 - 1/16" DIA. HOLE THROUGH

12 - 1/16" DIA. HOLES
EQUALLY SPACED # 45°
SCREW TO AXIS OF
NOZZLE

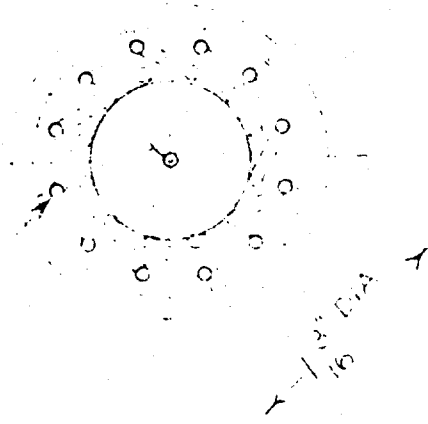

MANUAL

CONFIDENTIAL

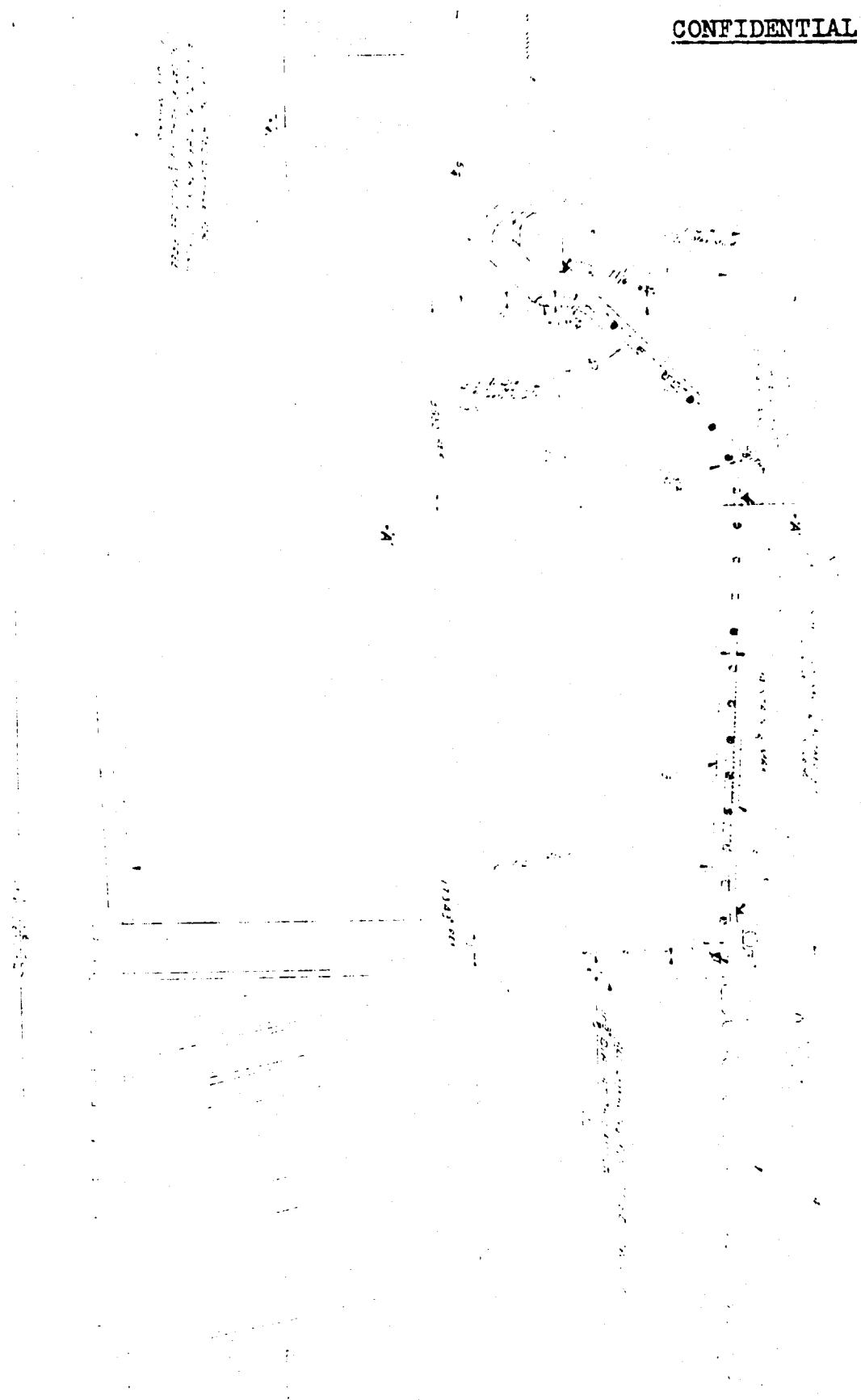

Best Available Copy

MODIFIED LINER IN CC-12 COMBUSTION CHAMBER
USED IN TEST RUNS #76 - 80

FIGURE 4

CONFIDENTIAL

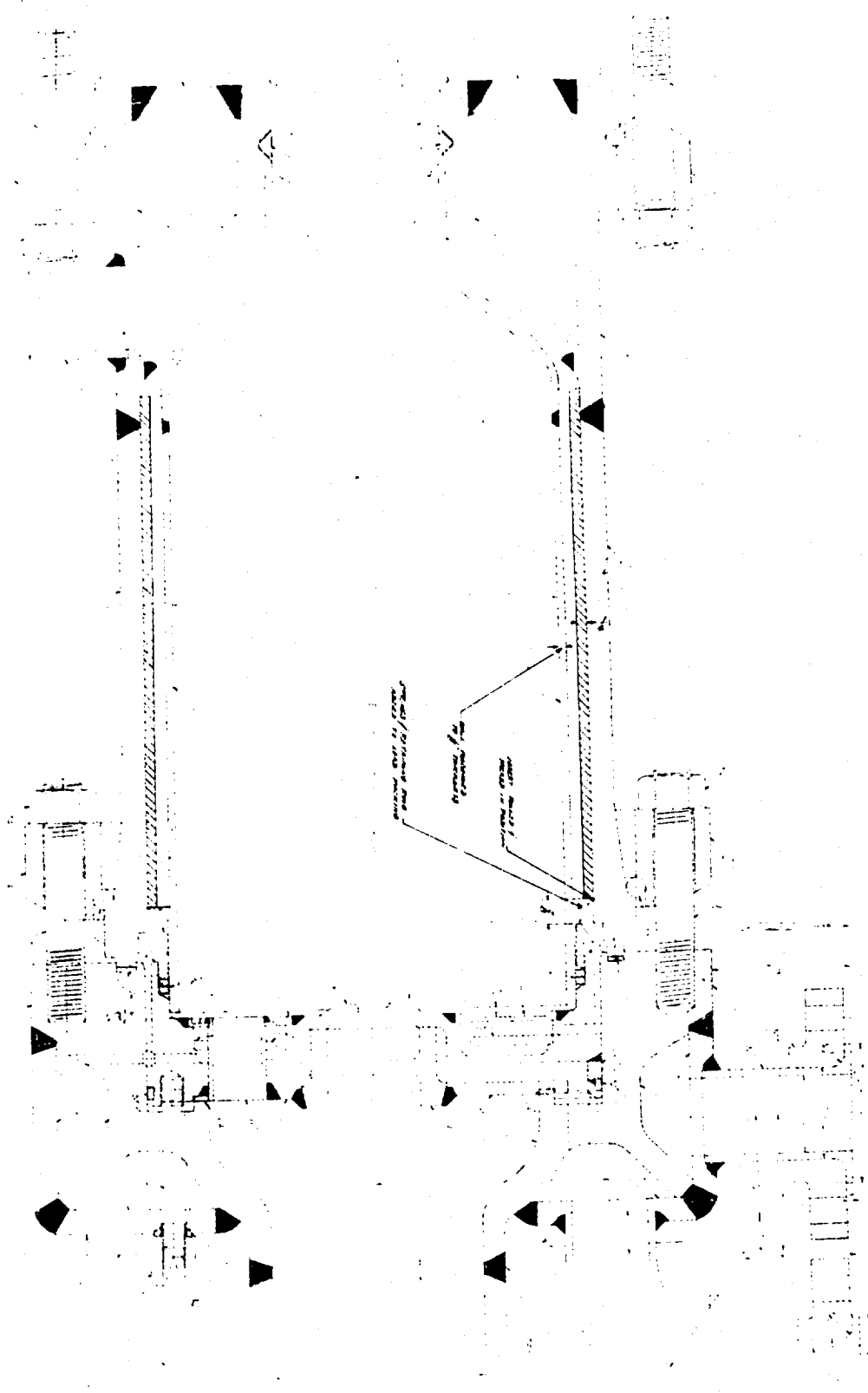

Best Available Copy

ENGINEERING EXPERIMENT STATION DESIGNED CC-13
COMBUSTION CHAMBER USED IN TEST RUNS #81 - 84

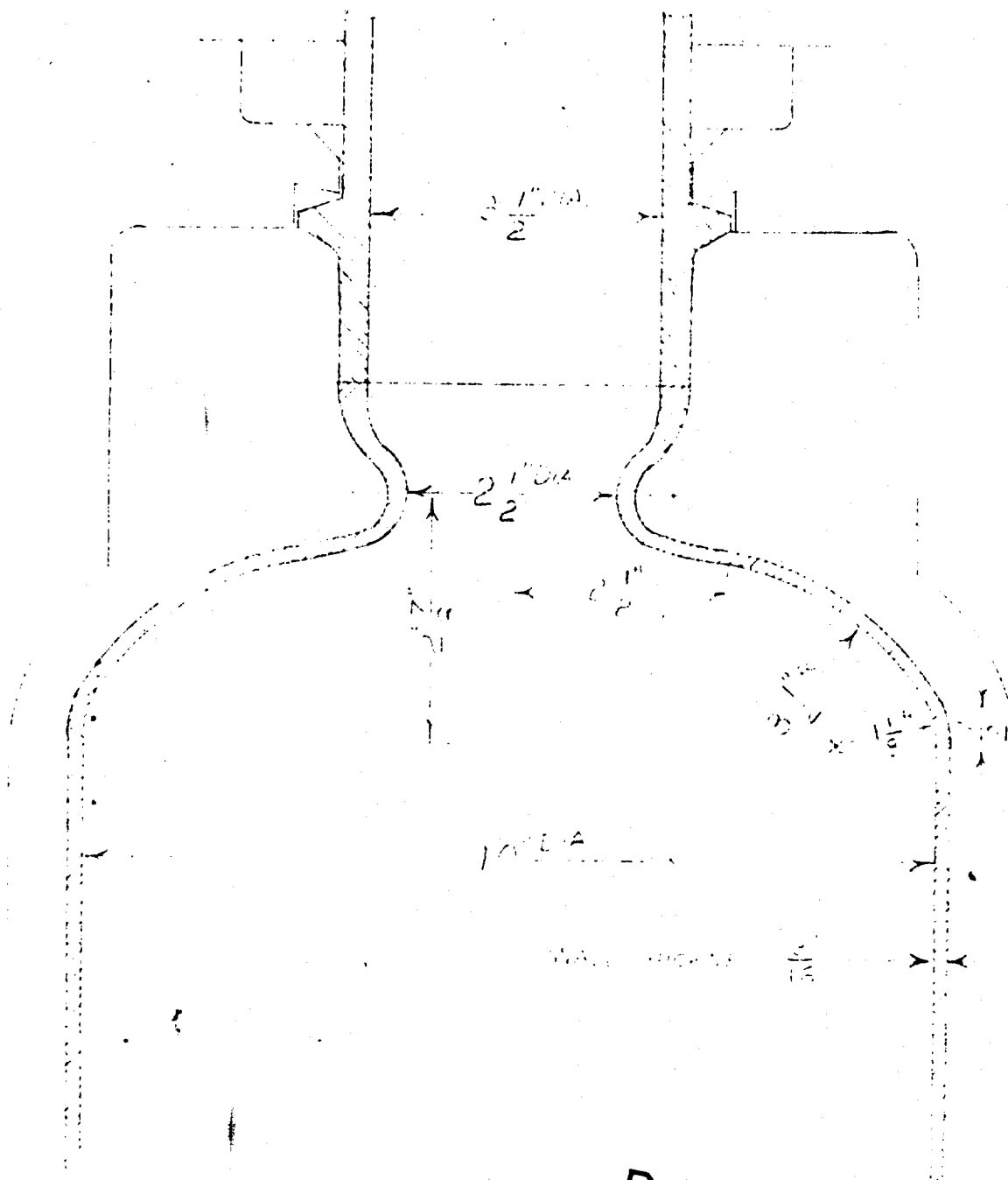

Best Available Copy

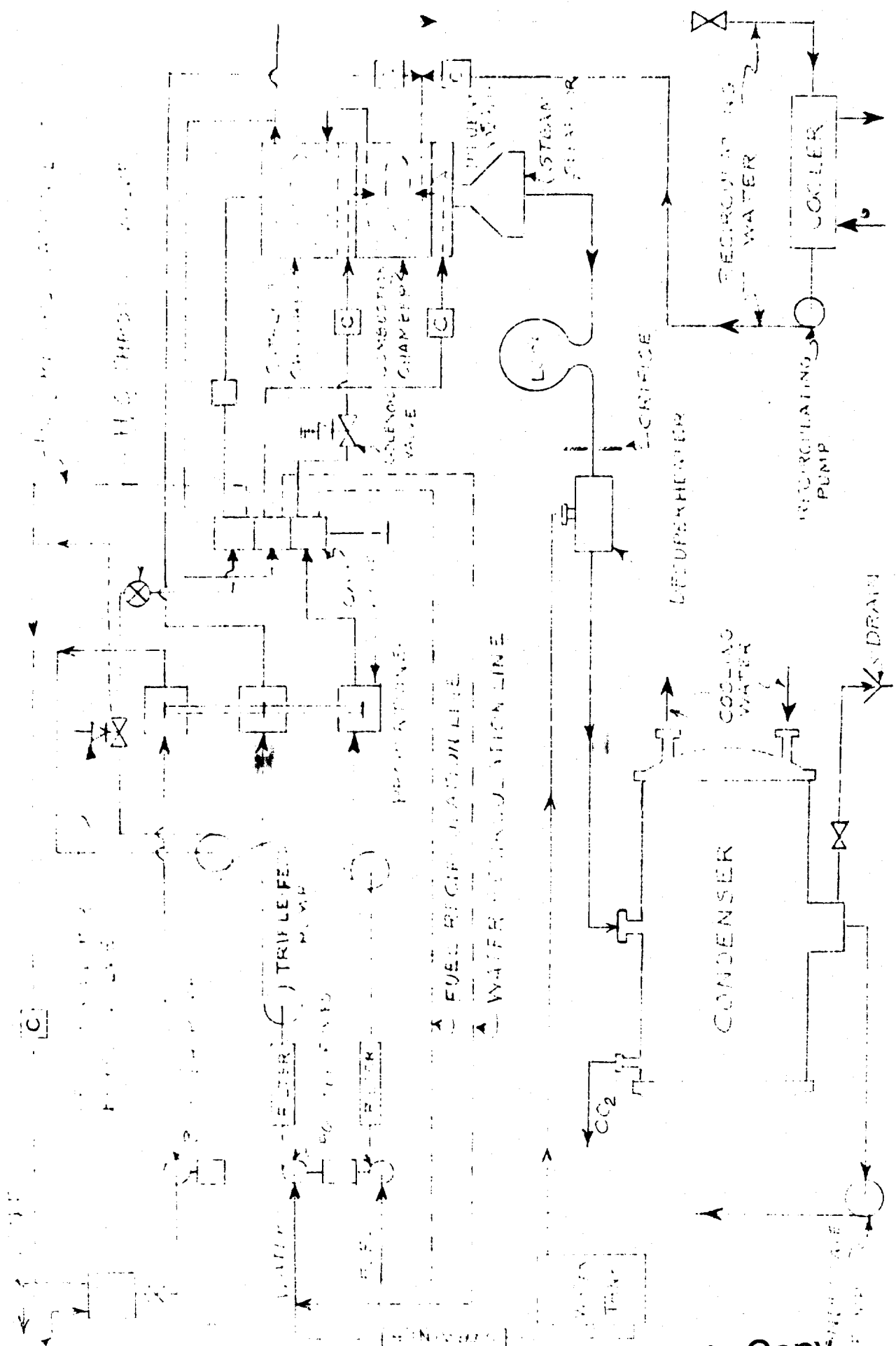

REFRIGERATION SYSTEM FOR THE ENGINE SYSTEM FOR THE ENGINEERING EXPERIMENTAL WORKS IN THE COMBUSTION ENGINE TESTING

FIGURE 8

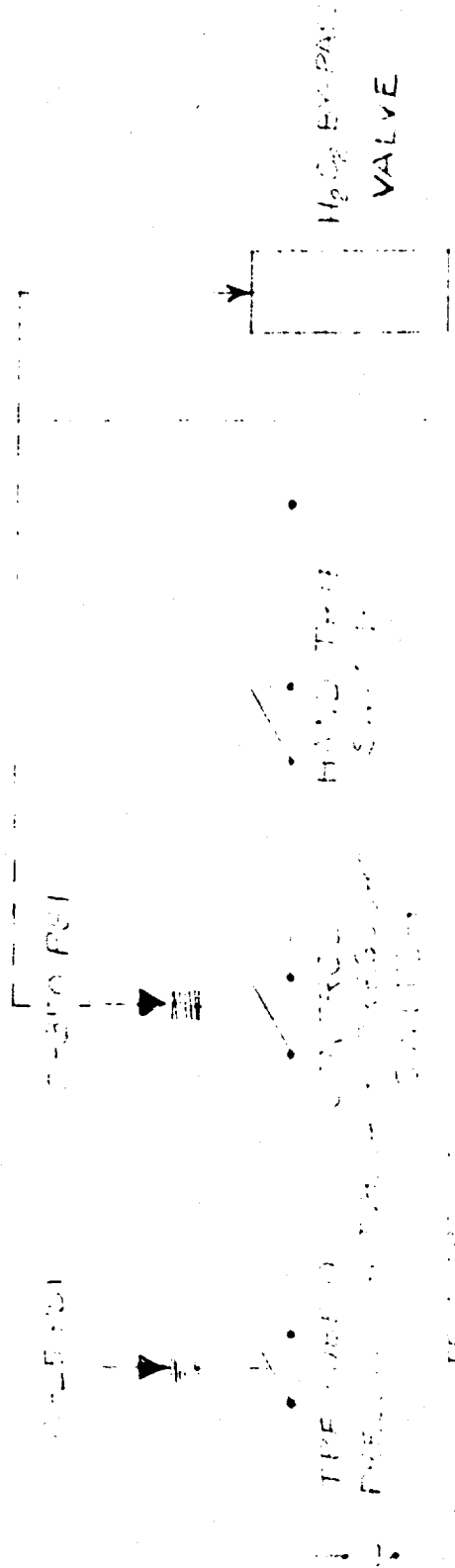

- THE TRIP-OUT CONTACT IS NORMALLY CLOSED
- PRESSURE TRANSDUCER IS NORMALLY OPEN
- TRIP-OUT CONTACT IS NORMALLY OPEN
- SYSTEM IS NORMALLY OPEN

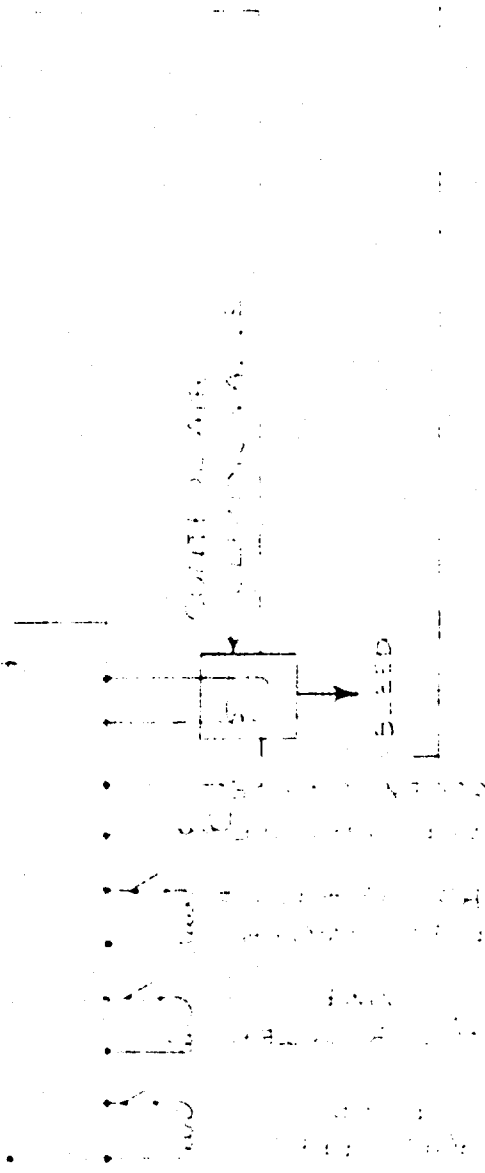

SAFETY TRIP-OUT SYSTEM
 INCORPORATED IN THE CONTROL SYSTEM
 OF THE SYSTEM AT G.E.S.

FIGURE 9 ST-1524

CONFIDENTIAL

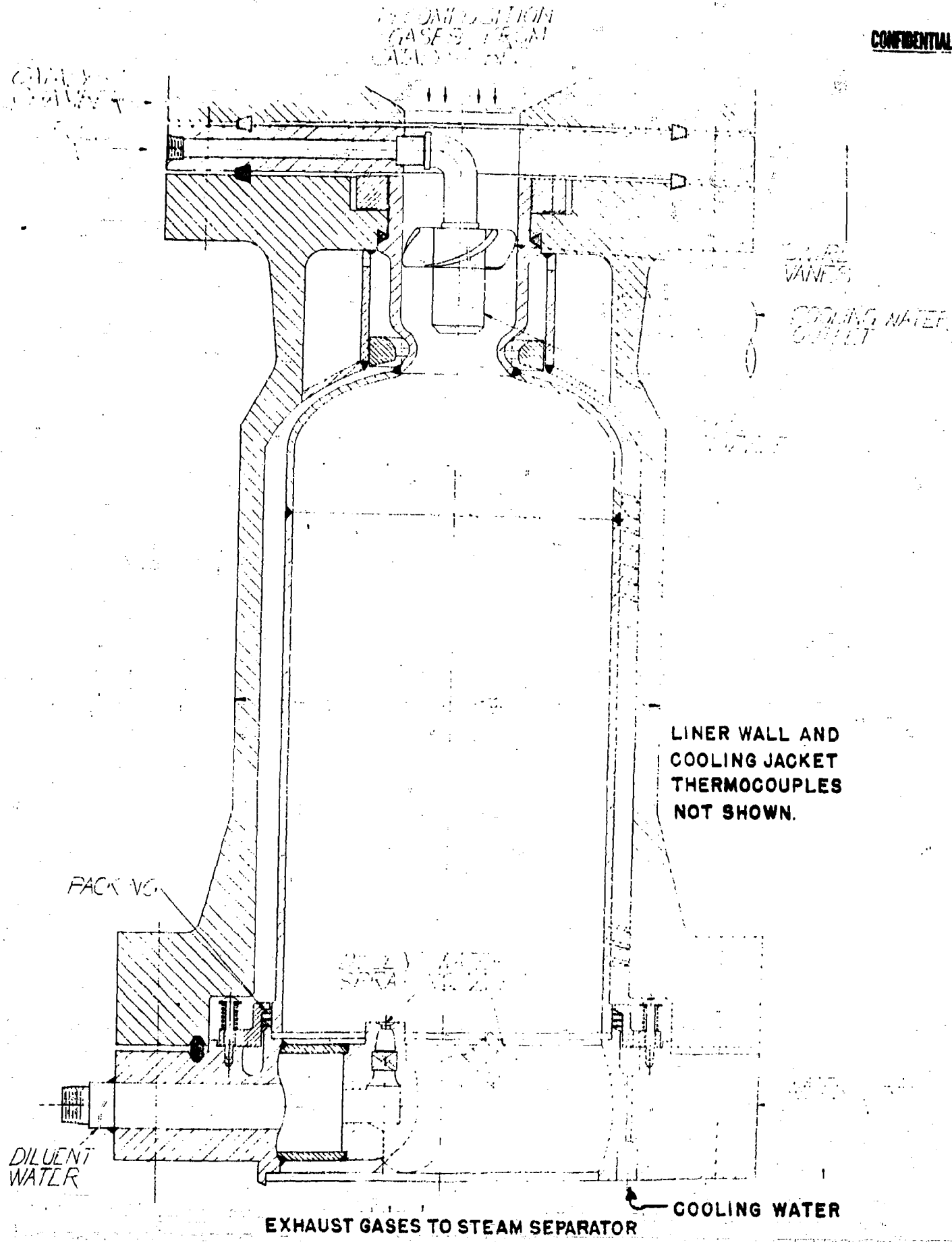

PLAN VIEW OF CC-12 COMBUSTION CHAMBER AS MODIFIED FOR TEST RUNS #1-5-128.

CONFIDENTIAL

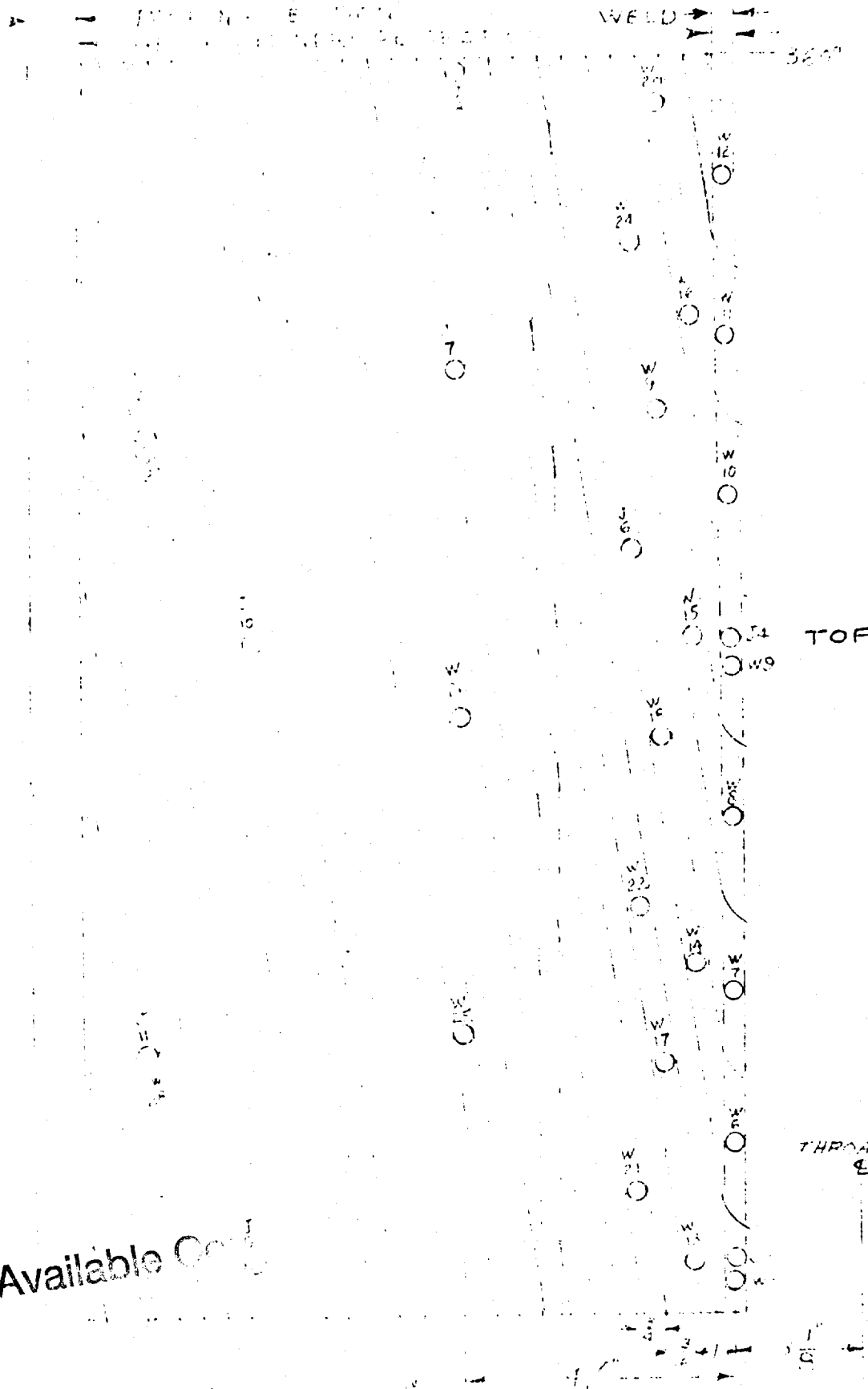

Best Available Copy

FOR SHOWING

(WATER)

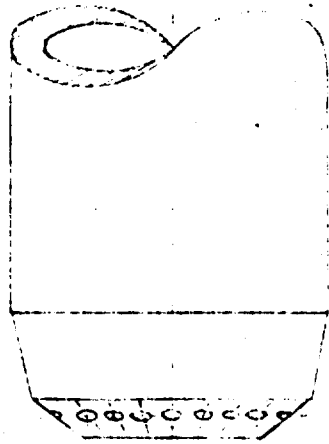

12 - $\frac{1}{16}$ " DIA. HOLES

24 - .067 DIA HOLES
SKEWED

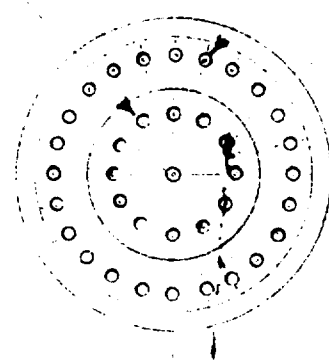

Best Available Copy

FOR INFORMATION ONLY
FOR USE ONLY BY 12F

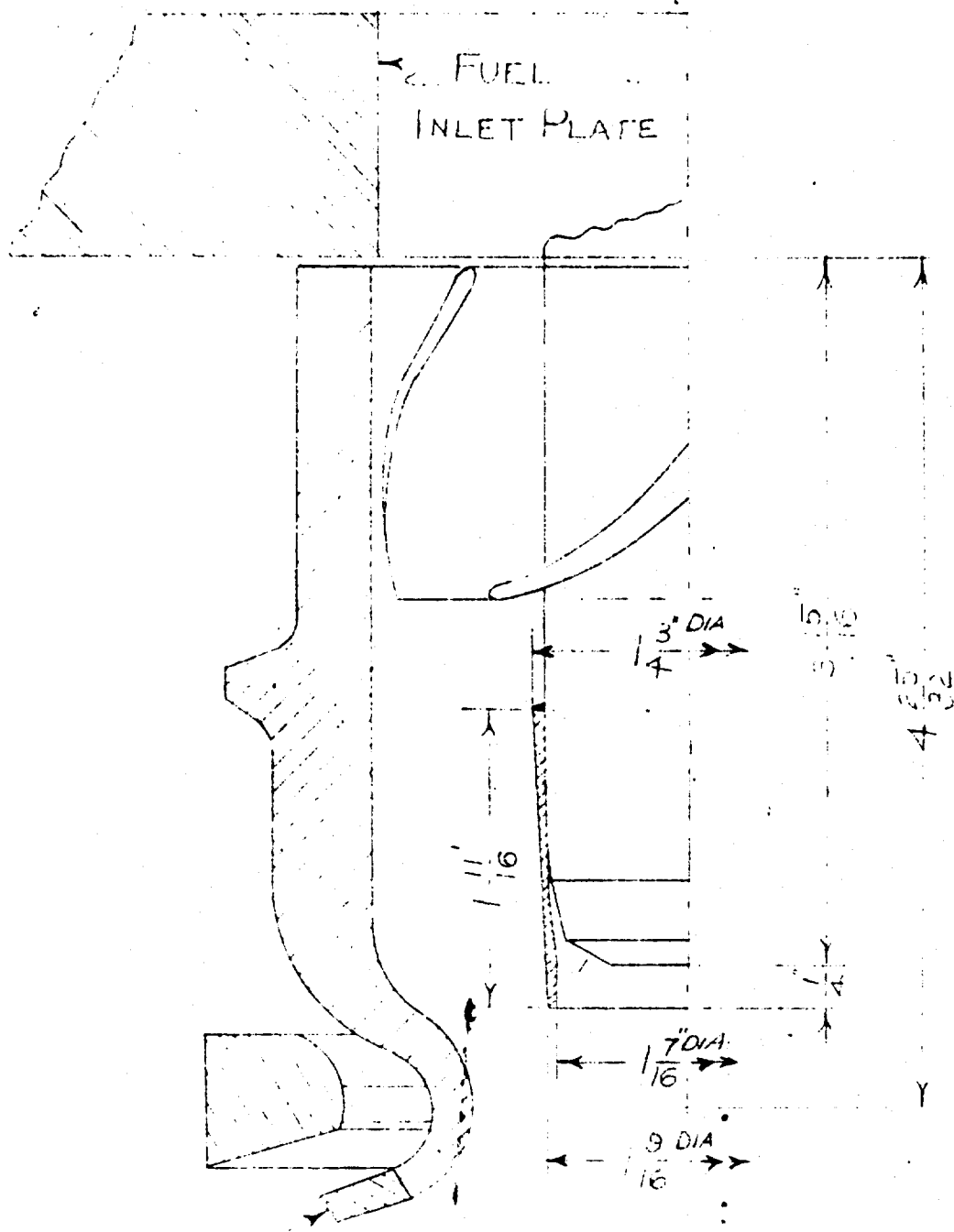

LINER

BAFFLE MAT'L
18-8 S.S.

Best Available Copy

FUEL INJECTOR INCORPORATING A SLEEVE
REF ID: A66414
MIL-STD-14-17-12B,
16-22-12B, APPENDIX 12BF

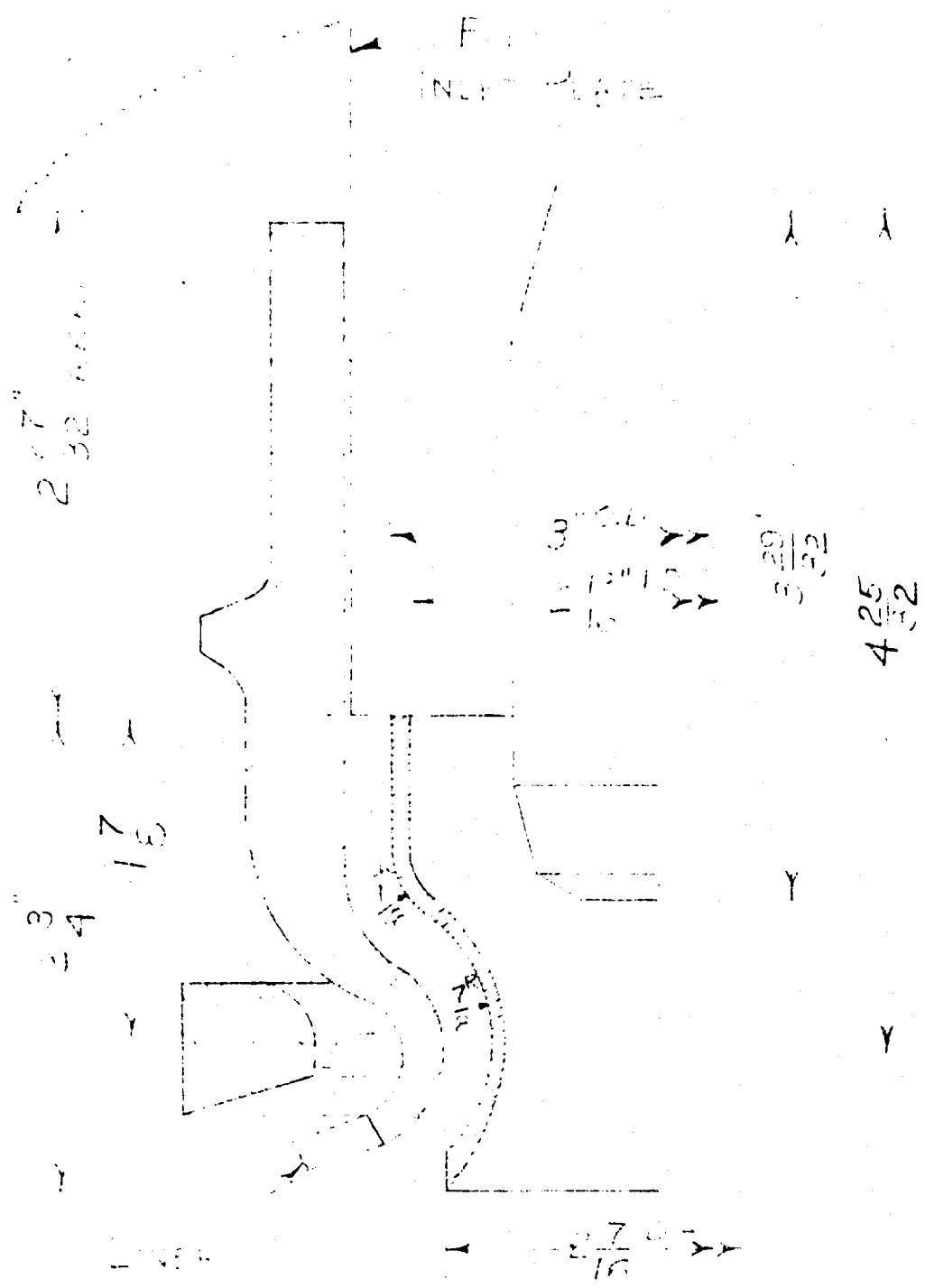

BARREL VALVE
18-8 SS.

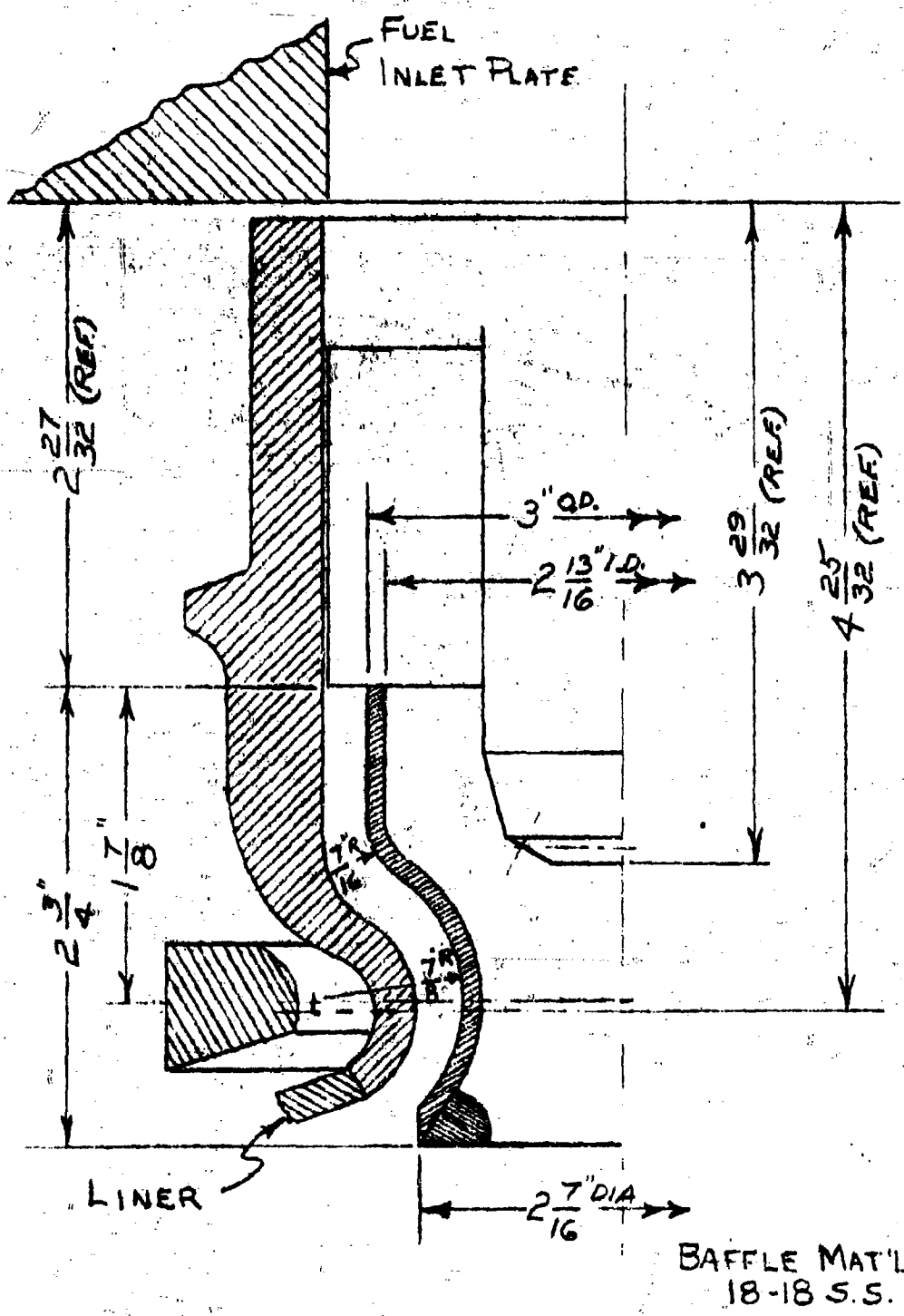

BAFFLE EVALUATED AS A CONTROL FOR THE OXIDANT GAS STREAM. MODEL 12B2B USED IN TEST.
RUN #25-12B

CONFIDENTIAL

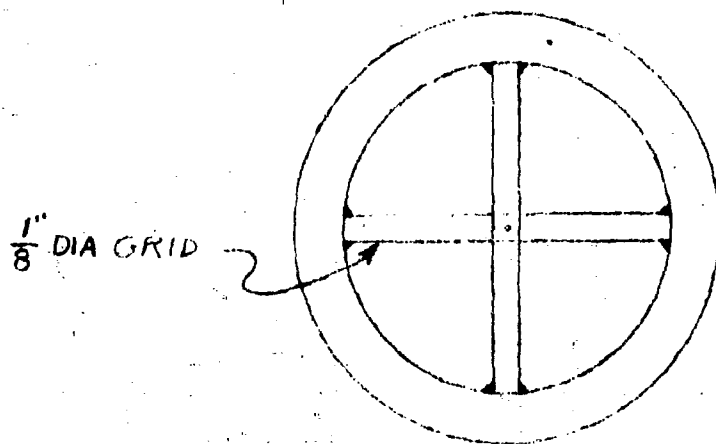
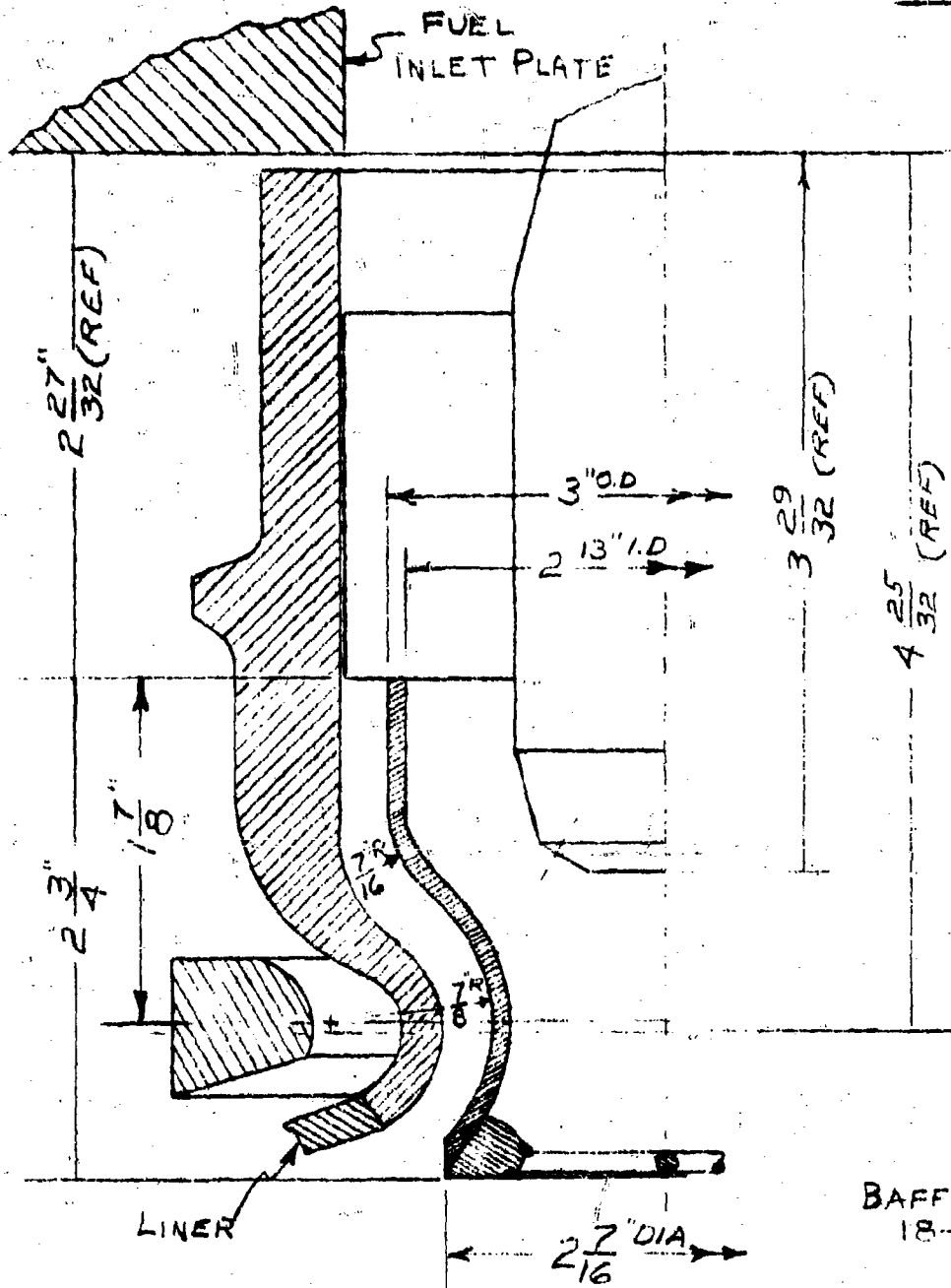

BAFFLE EVALUATED AS A CONTROL FOR THE
OXIDANT GAS STREAM AND A POSSIBLE FLAME
HOLDER. MODEL 12B20 USED IN TEST RUN #26-12B.

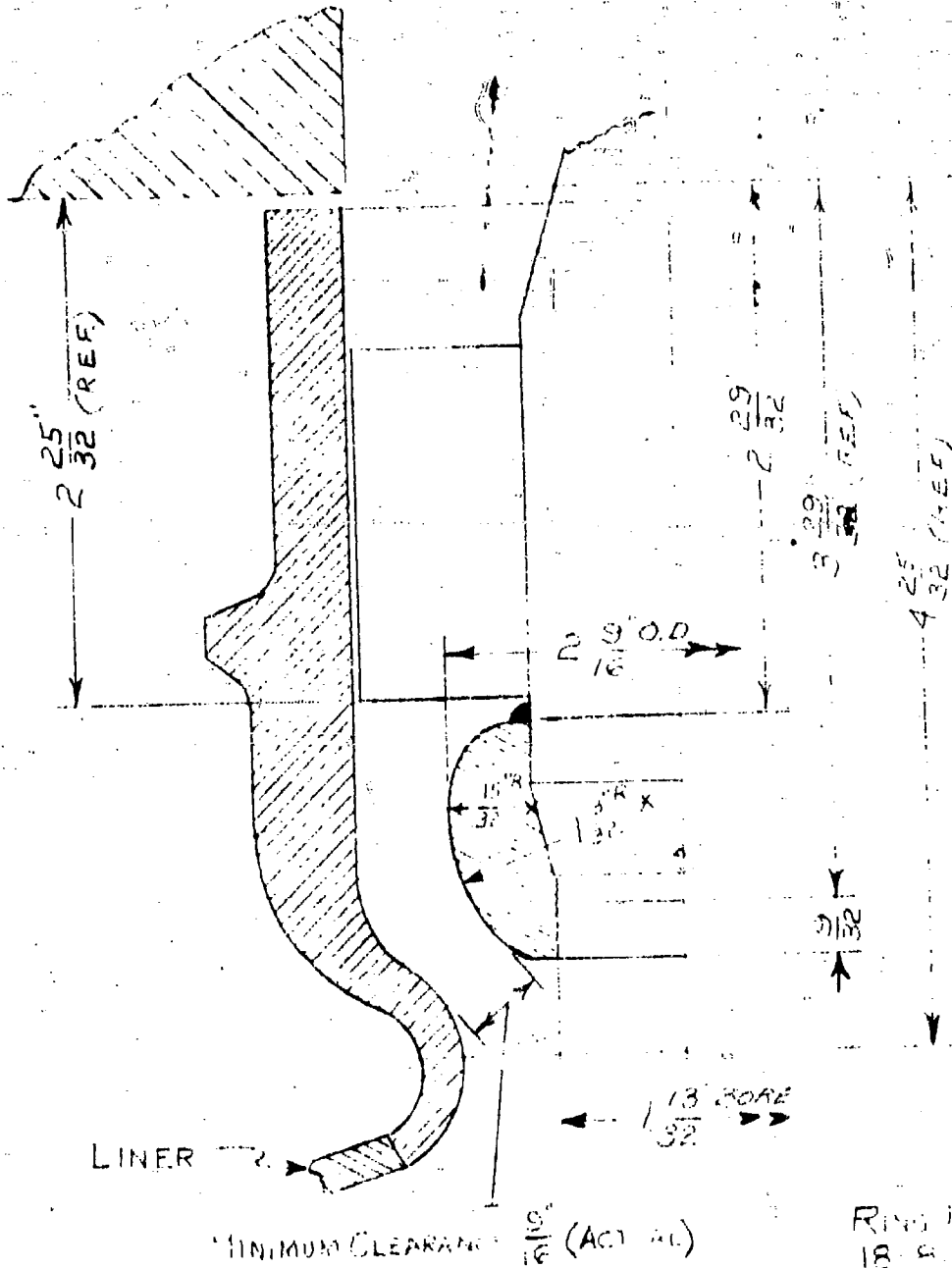

BECCO DESIGNED "DONUT" BAFFLE
AS MOUNTED ON THE FUEL NOZZLE
MODEL NO. 12BE - USED IN TEST RUNS
NO. 27 & 29-12B

ROLL
NECK
PLATE

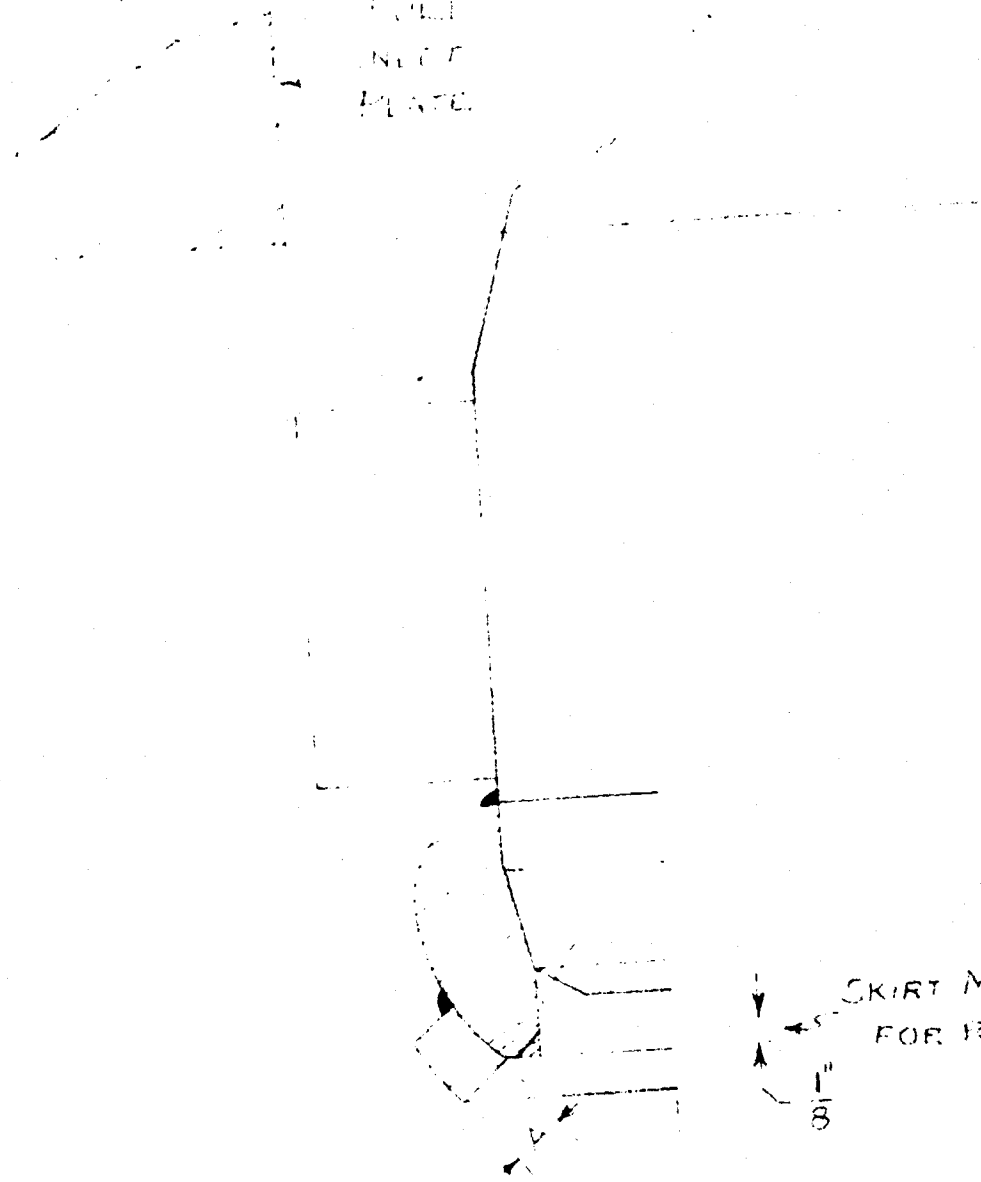

SKIRT MODIFICATION
FOR RUNS 43-45-12B

1/8"

Handwritten notes and dimensions:
A. 1/2" - 1/4"
B. 1/2" - 1/4"
C. 1/2" - 1/4"
D. 1/2" - 1/4"
E. 1/2" - 1/4"
F. 1/2" - 1/4"
G. 1/2" - 1/4"
H. 1/2" - 1/4"
I. 1/2" - 1/4"
J. 1/2" - 1/4"
K. 1/2" - 1/4"
L. 1/2" - 1/4"
M. 1/2" - 1/4"
N. 1/2" - 1/4"
O. 1/2" - 1/4"
P. 1/2" - 1/4"
Q. 1/2" - 1/4"
R. 1/2" - 1/4"
S. 1/2" - 1/4"
T. 1/2" - 1/4"
U. 1/2" - 1/4"
V. 1/2" - 1/4"
W. 1/2" - 1/4"
X. 1/2" - 1/4"
Y. 1/2" - 1/4"
Z. 1/2" - 1/4"

Best Available Copy

THIS IS NOT A DRAWING OF A PART
WHICH IS BEING MANUFACTURED
OR WHICH IS TO BE MANUFACTURED

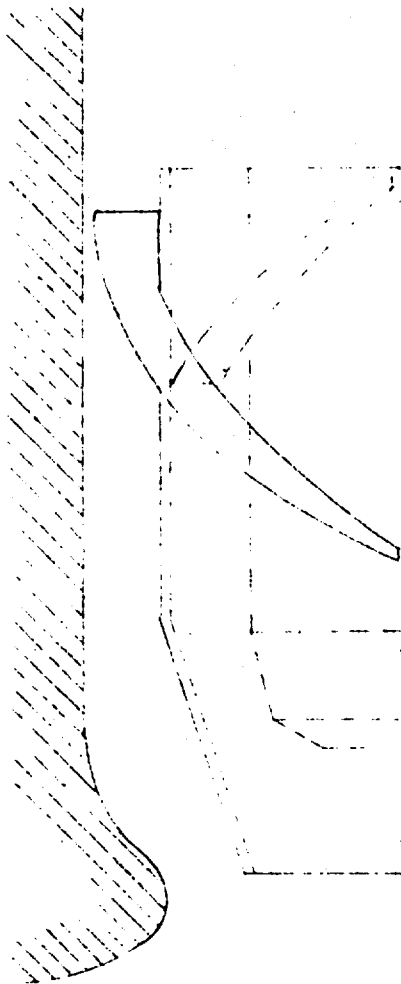

ARCE ASSOCIATES DESIGNED AND
SWIRL PERFORMANCE INDICATED PROFILE
USE - FIG. 100 # 40 1/2"

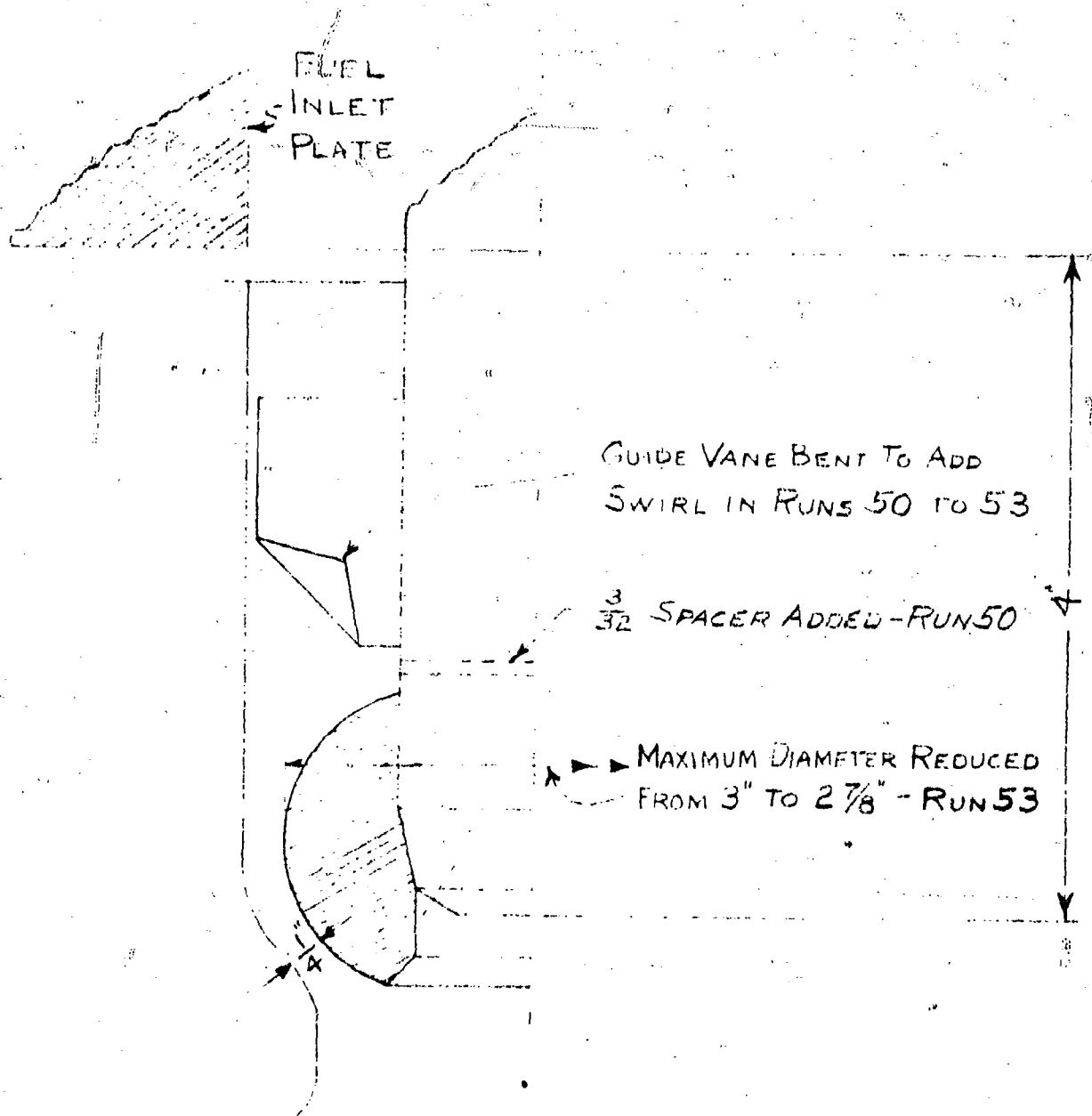

DONUT BAFFLE AS REDESIGNED AND BUILT WITH $\frac{1}{4}$ "
THROAT TO BAFFLE CLEARANCE USED IN TEST
RUNS # 48-53-12B.
MODEL 12B2P

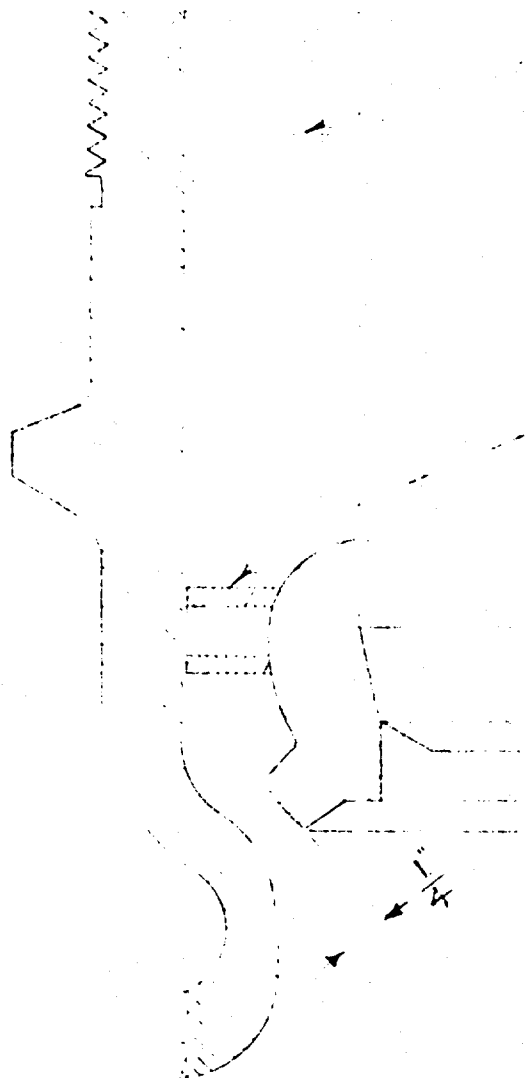

GUIDE VANES
RUN 54-56-12B
REMOVED AFTER
RUN 55-12B

1/4 FIRE GUIDES
4 EQUALLY SPACED
ADDED AFTER RUN 55-12B

THIS SAMPLE AS MODIFIED FOR
TEST RUNS # 54-56, 58-66-12B

CONFIDENTIAL

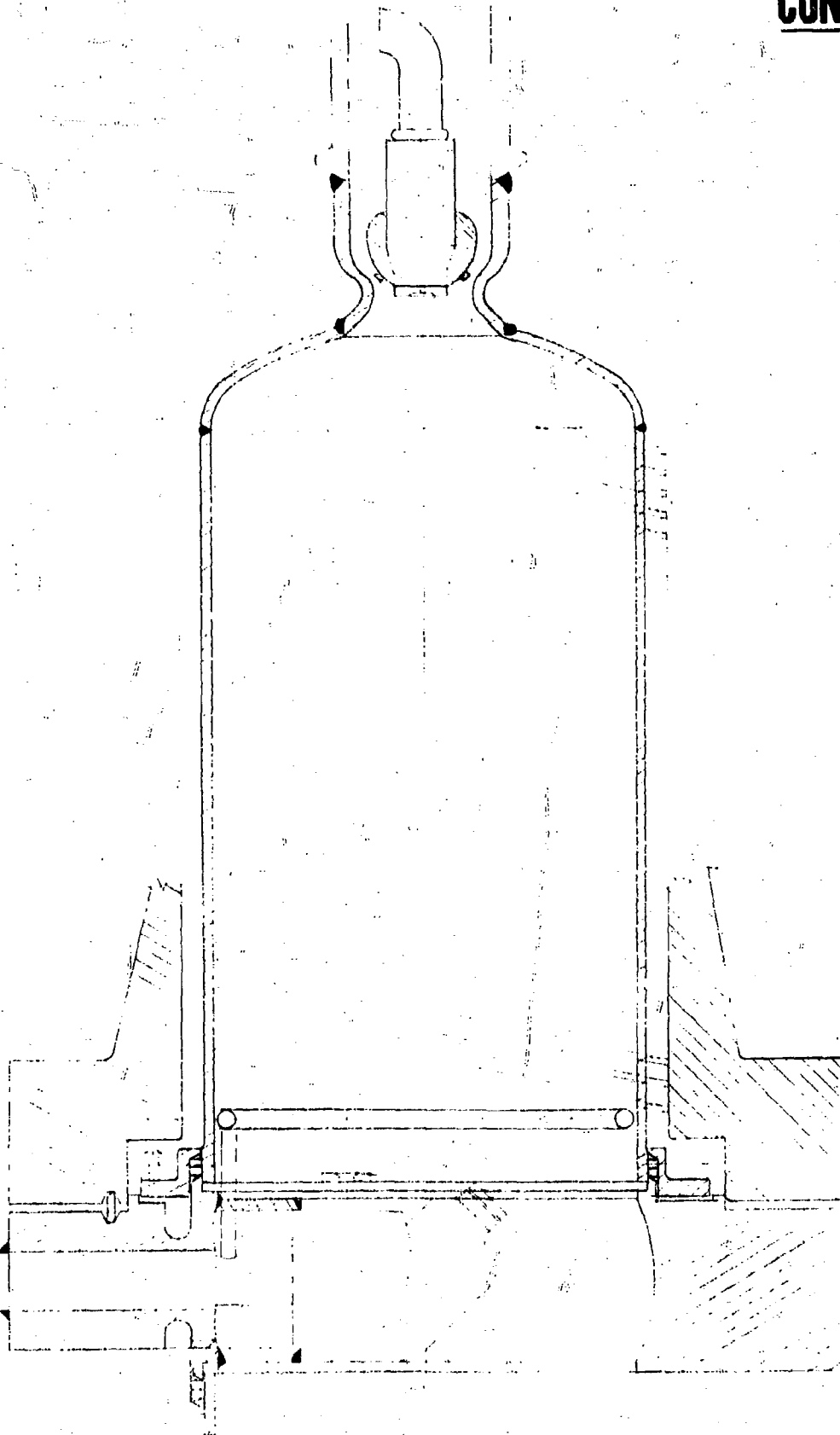

MODIFIED CC-12 COMBUSTION
CHAMBER INCORPORATING A
WATER SPRAY RING AT THE
UNCOOLED LINER PACKING SECTION

CONFIDENTIAL

CONFIDENTIAL

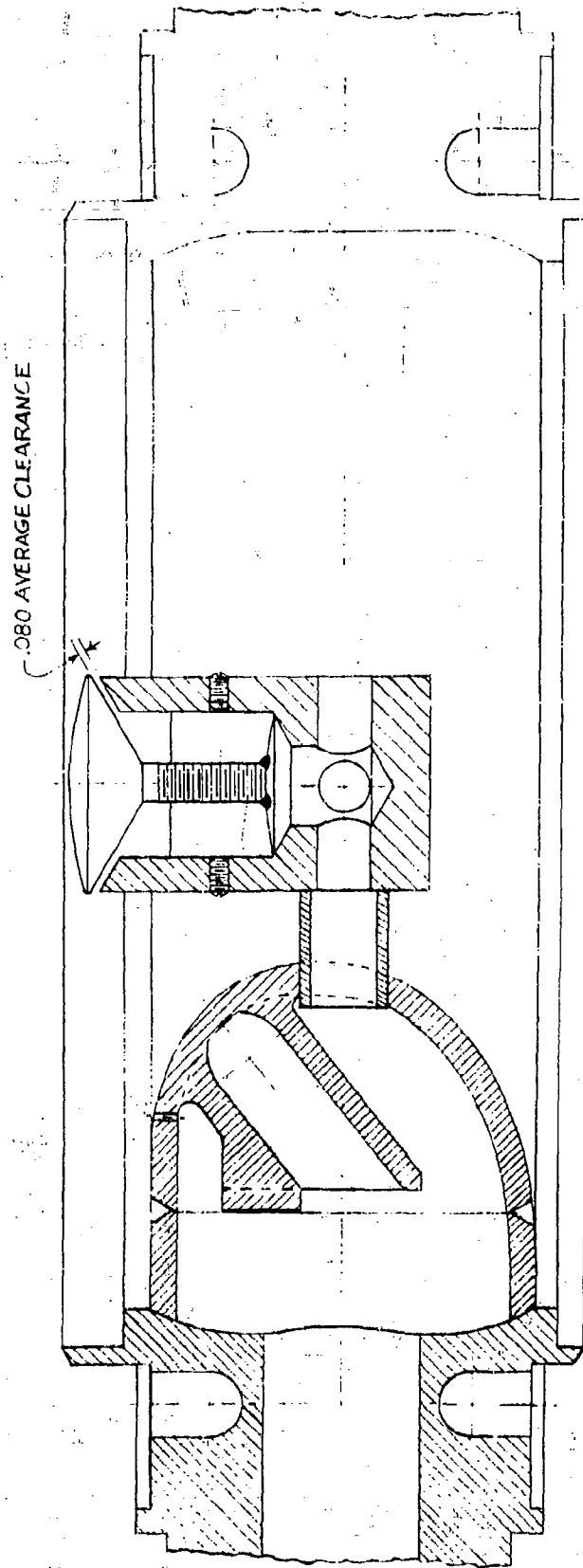

BECCO DESIGNED UMBRELLA
TYPE SINGLE DILUENT WATER
NOZZLE AS MOUNTED IN THE
CC-12 CHAMBER FOR TEST
RUNS #63-64-12B

CONFIDENTIAL

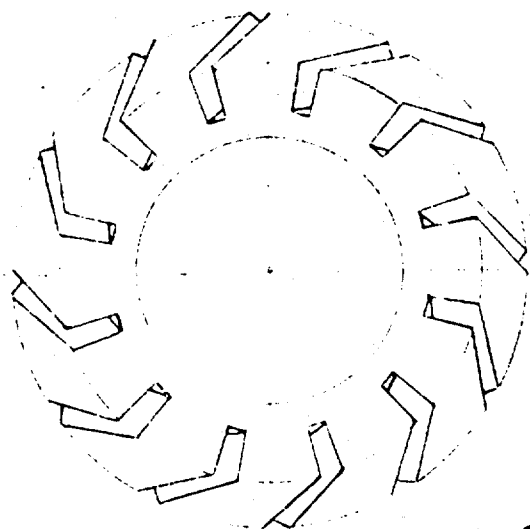
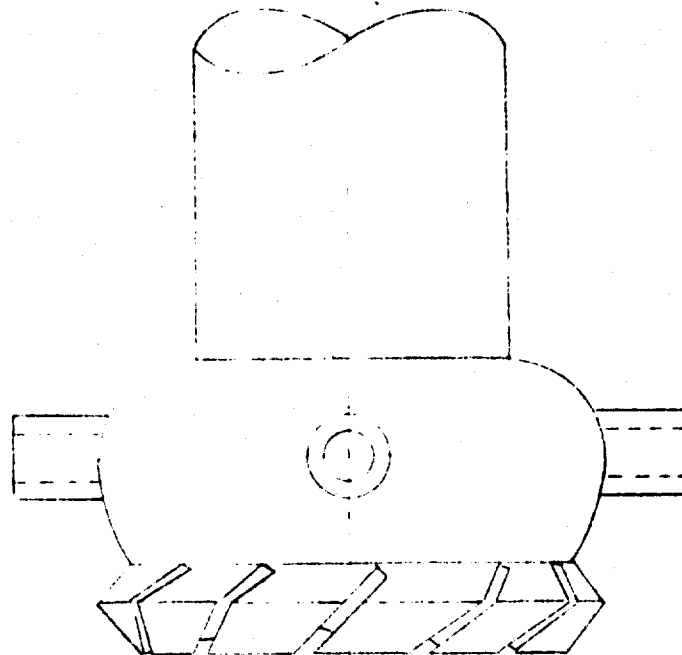

Best Available Copy

THIS DRAWING IS MODIFIED BY THE
APPROPRIATE AUTHORITY. THE
DATE OF THE MODIFICATION IS
1964-08-12

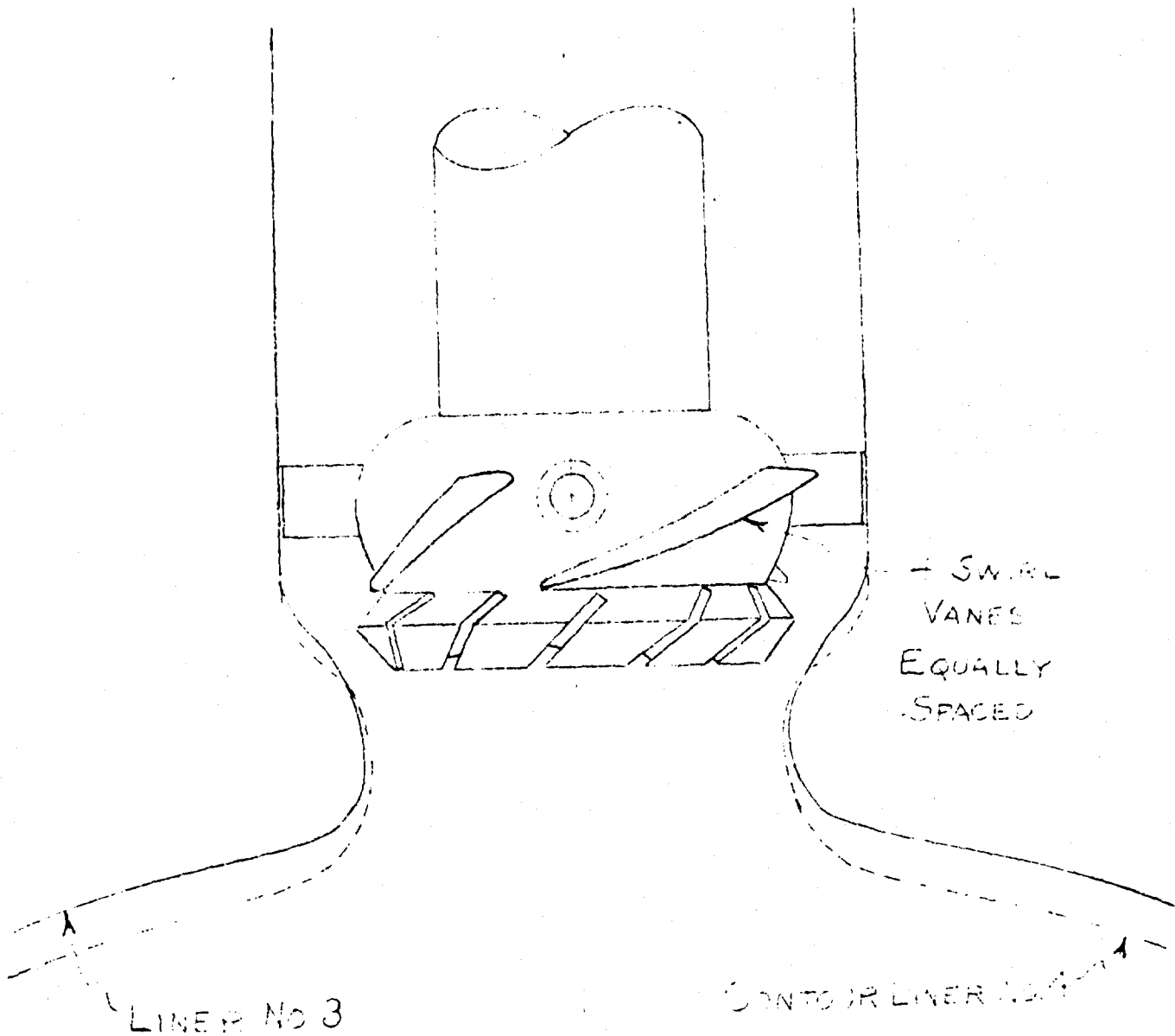

IRON HAFEL A. M. 1945
 MOUNTED FOR TEST RIGS #20-23-25

Best Available Copy

CONFIDENTIAL

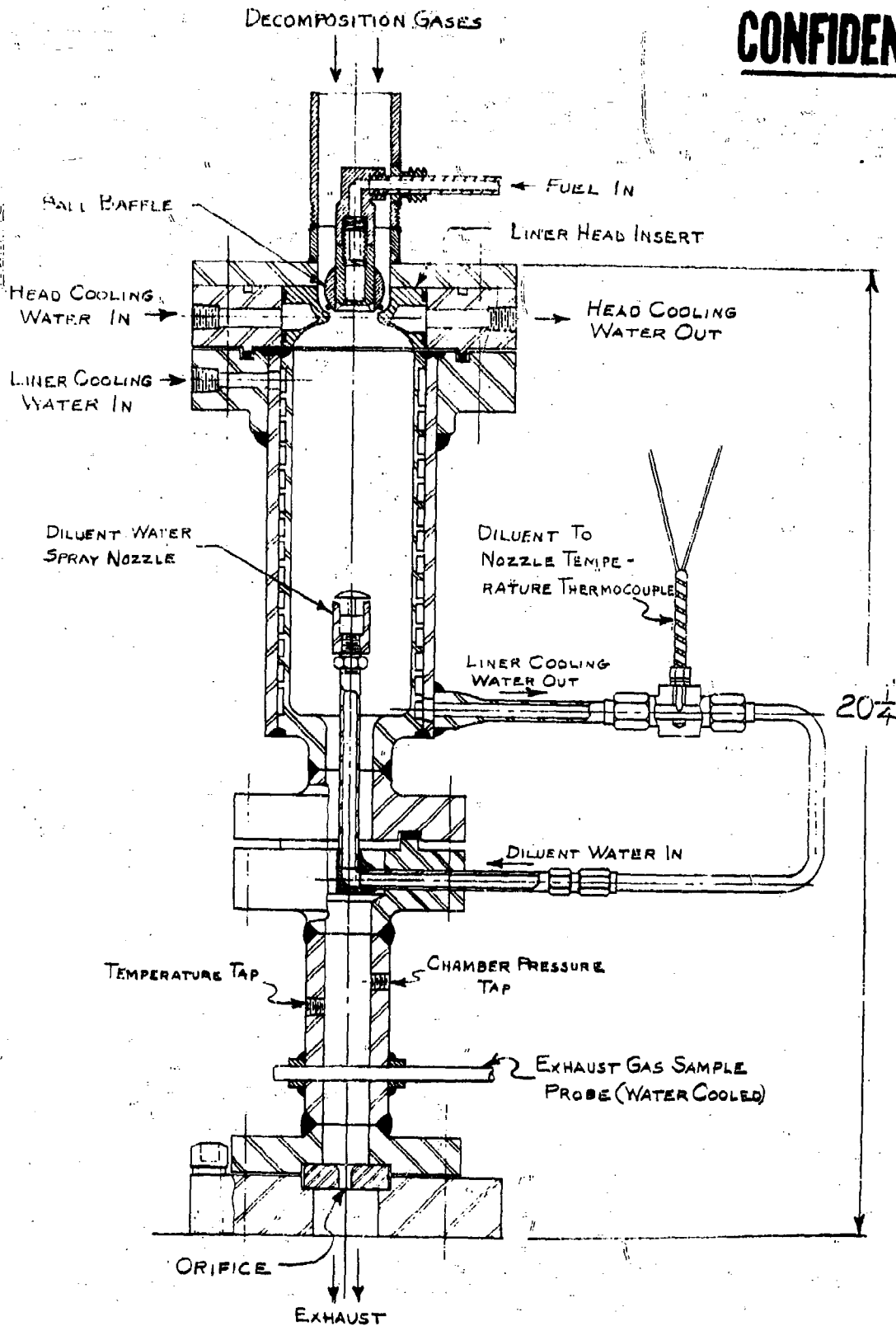

COMBUSTION CHAMBER CONFIGURATION
USED IN TEST AT BECCO. 2 1/2" I.D. x 5"
COMBUSTION ZONE.

CONFIDENTIAL

BY AFL DATE 4-3-56
CHKD BY JAG DATE 4-13-56
SCALE: NONE

SUBJECT SCHEMATIC FLOW
DIAGRAM FOR ONR
TEST SYSTEM

SHEET NO. 1 OF 1
JOB NO. 206
SP-1793

BECCO CHEMICAL DIVISION
FOOD MACHINERY AND CHEMICAL CORPORATION
SPECIAL PROJECTS

CONFIDENTIAL

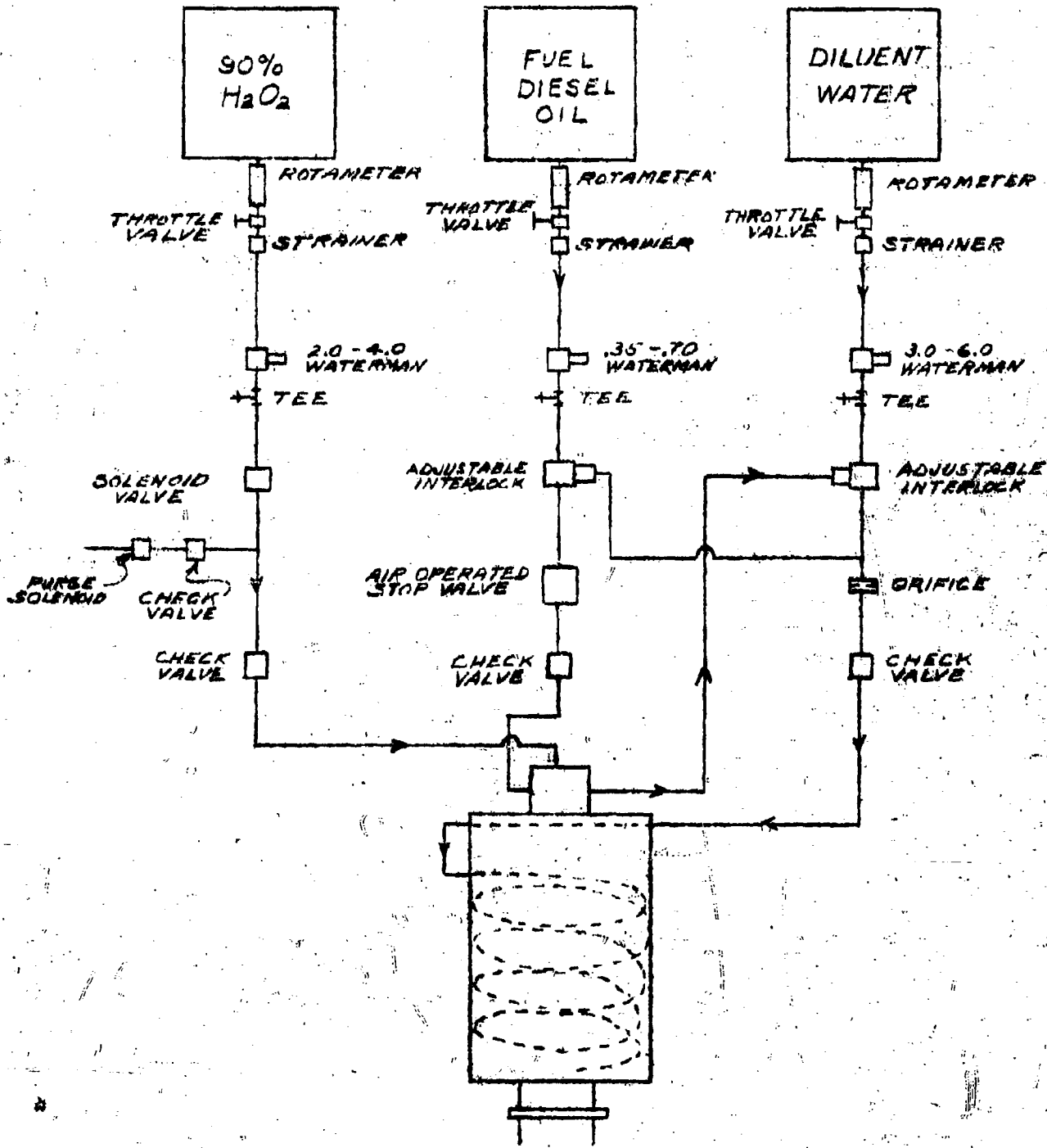

FLOW SYSTEM USED IN COMBUSTION
CHAMBER TESTS AT BECCO.

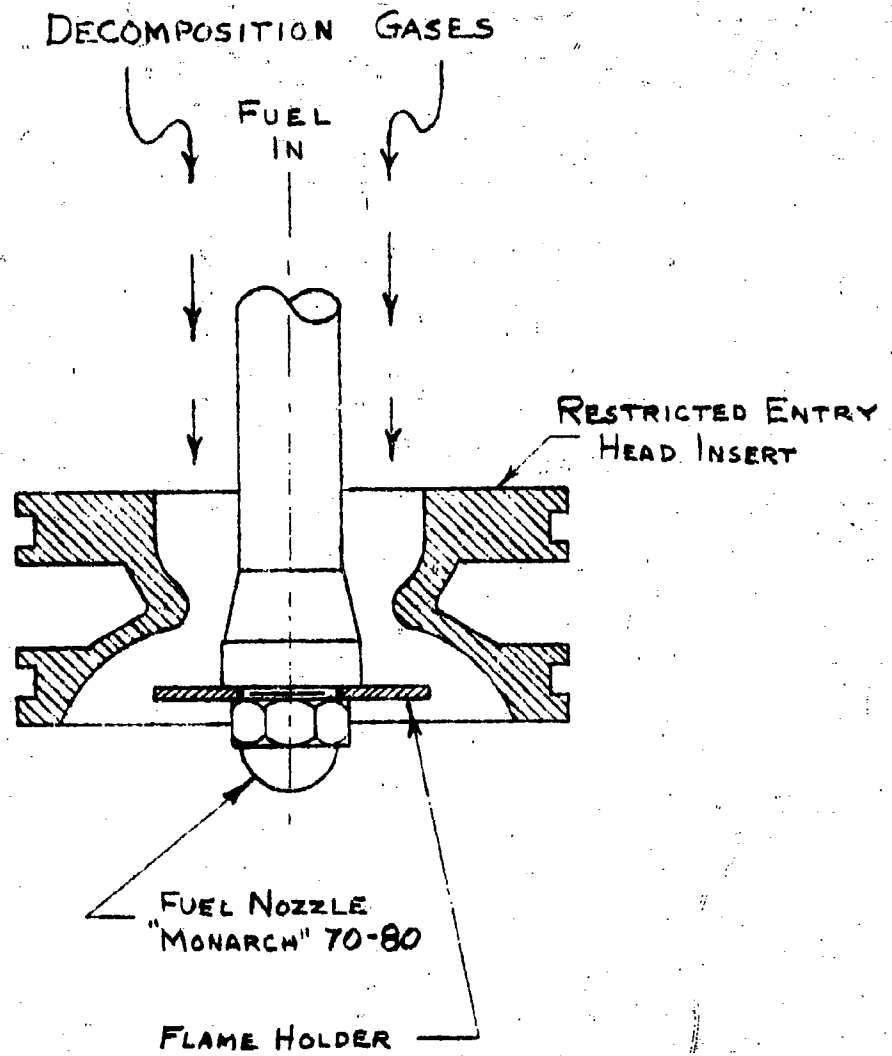

BECCO COMBUSTION TESTS
FLAT FLAME HOLDER THROUGH
RESTRICTED ENTRY HEAD INSERT

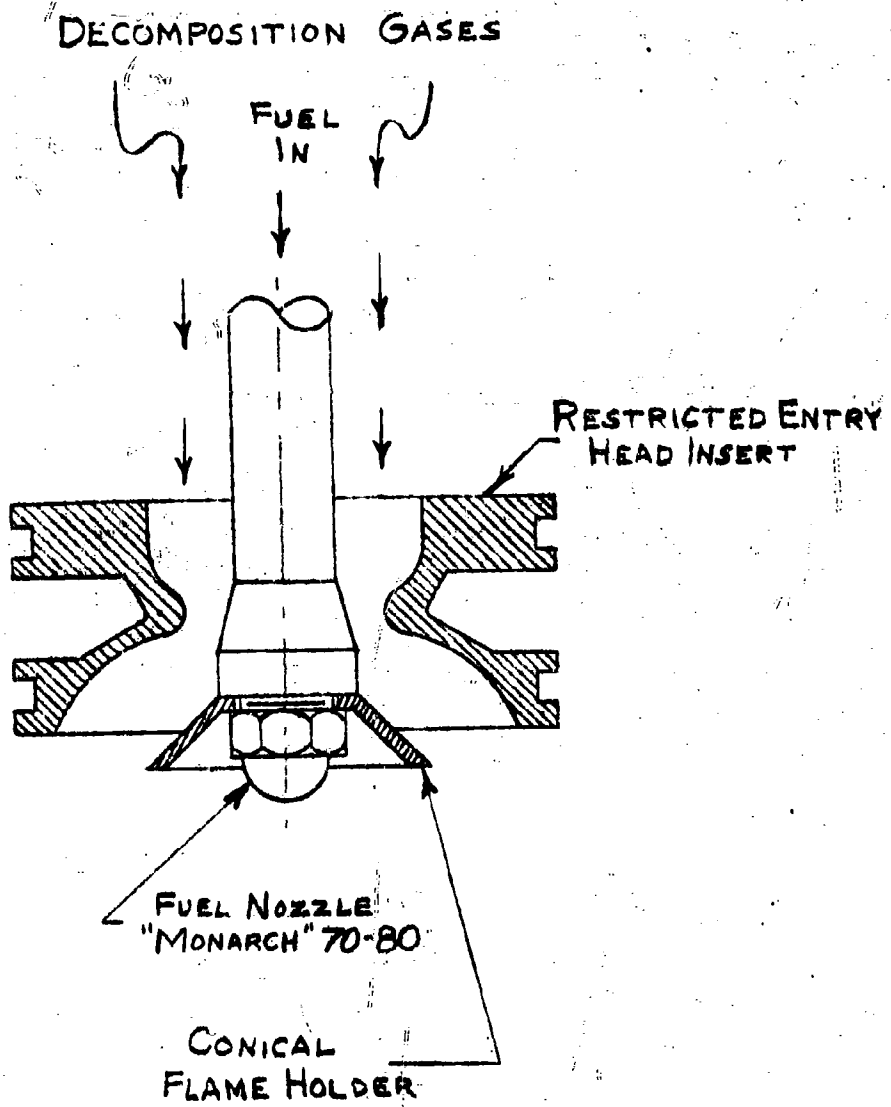

BECCO COMBUSTION TESTS
CONICAL FLAME HOLDER THROUGH
RESTRICTED ENTRY HEAD INSERT

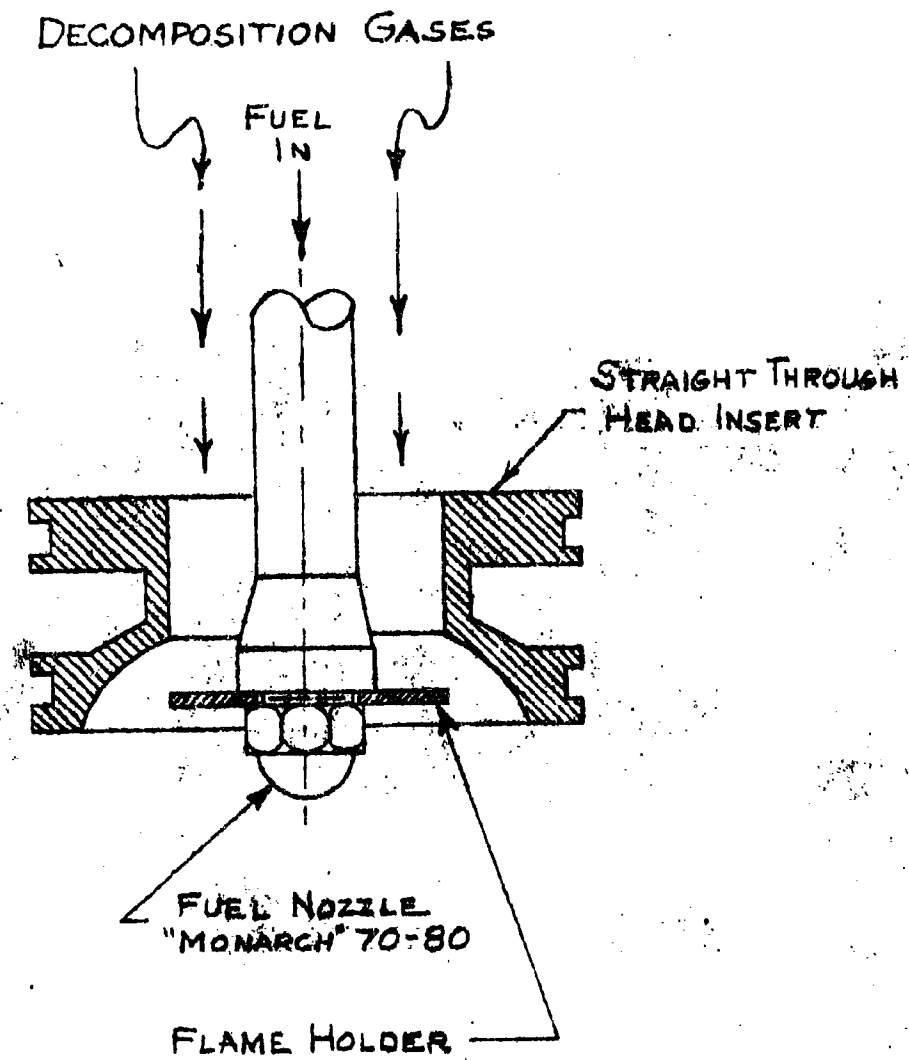

BECCO COMBUSTION TESTS
FLAME HOLDER STRAIGHT THROUGH
HEAD

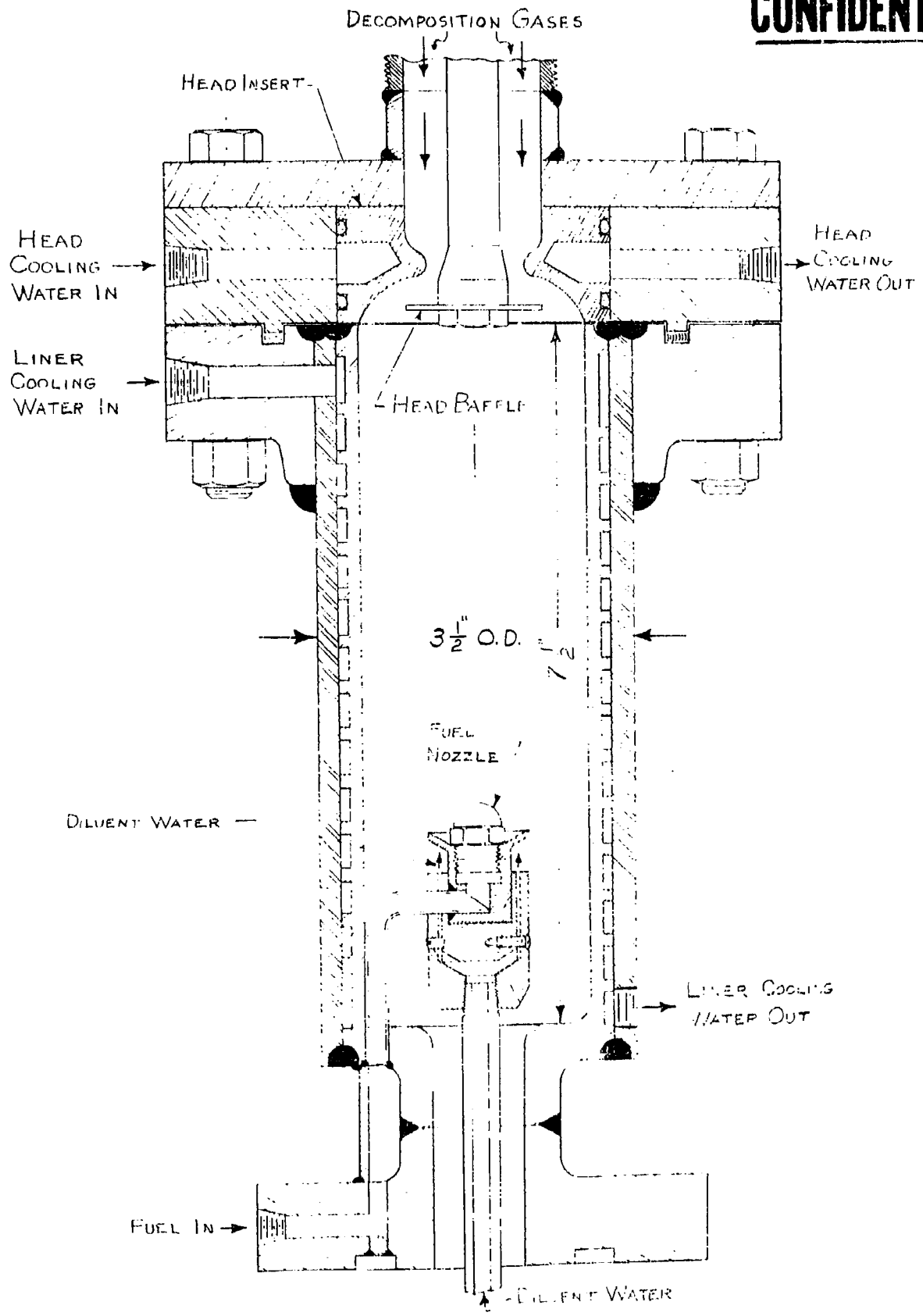

REVERSE FLOW TEST ASSEMBLY
USED IN TESTS AT BECCO

FIGURE 31

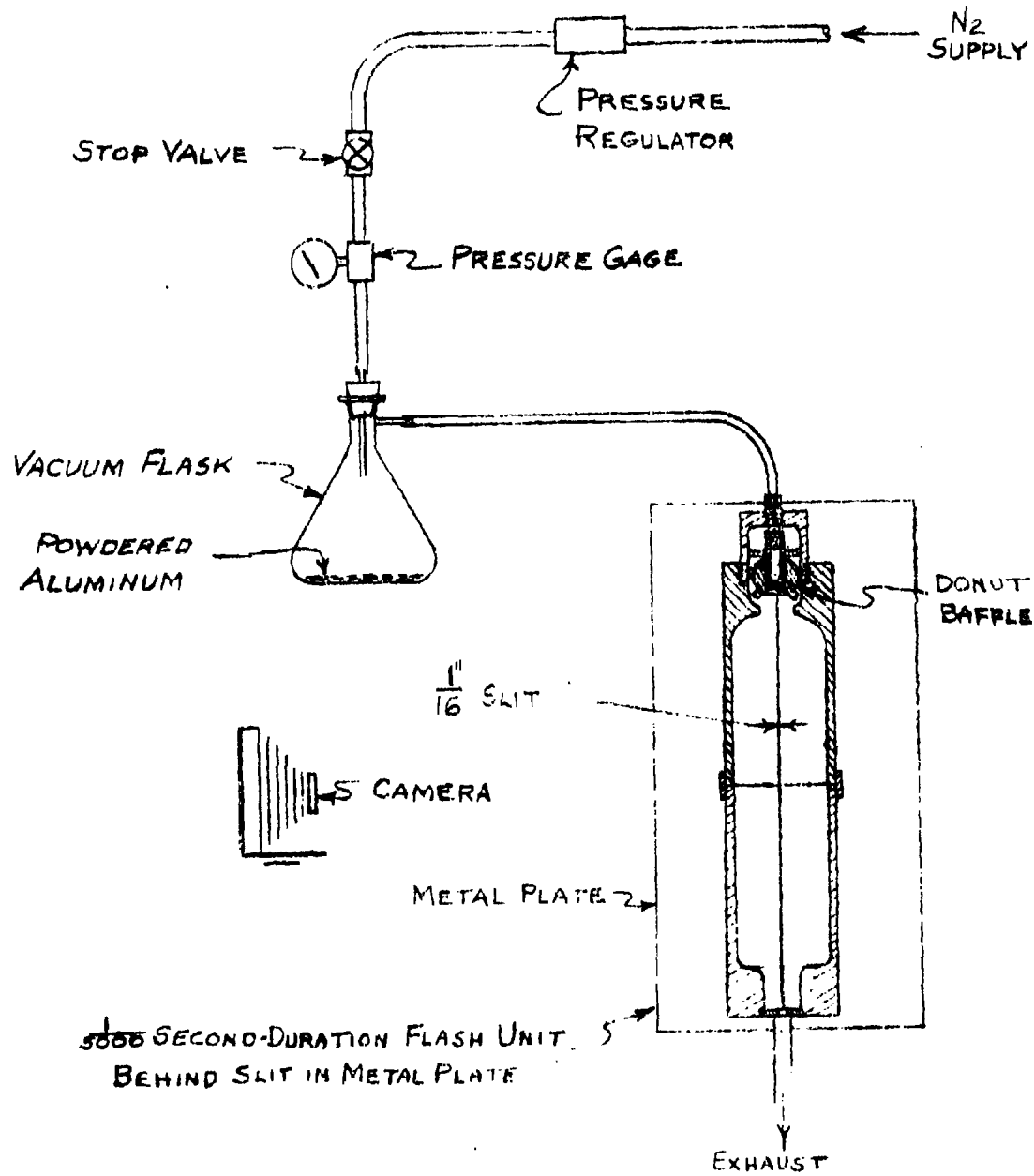

APPARATUS USED TO STUDY THE FLOW CHARACTERISTICS IN A TRANSPARENT MODEL COMBUSTION CHAMBER USING HIGH SPEED PHOTOGRAPHY

C O N F I D E N T I A L

APPENDIX A

In addition to designing liner No. 4, presenting the dual swirl nozzle, and making a preliminary analysis of the fuel spray in the modified Alton combustion chamber, Arde Associates of Newark, New Jersey, was contracted by Becco to develop an analytical expression of turbulent, H_2O_2 supported high pressure combustion.⁽⁹⁾ The report is summarized here to show the excellent correlation between the performance predicted by the expressions developed in the report and the actual performance of the modified Alton chamber. The factors that would increase performance as indicated by the expressions developed are, therefore, substantiated within the limitations imposed by the conditions not taken into account in the derivations.

The report develops an equation from which an approximation can be made of the time required for the complete burning of liquid fuel droplets sprayed into a high pressure combustion region supported by the decomposition products of H_2O_2 . The derivation begins with the consideration of the burning of a single droplet in static oxygen-rich surroundings. The model assumed consists of a spherical liquid droplet surrounded by a concentric spherical flame of negligible thickness. The flame is located at a distance which is determined by the location of stoichiometric proportioning of evaporated fuel diffusing outward from the droplet and oxygen transported and diffused toward the flame. The products of combustion spread outward from the flame. The principle additional assumptions made were as follows:

- (a) the heat value, thermal conductivity, specific heat, and diffusivity of each unit mass of evaporated fuel are constant.

(9) loc. cit. Arde Associated 2567-1

C O N F I D E N T I A L

CONFIDENTIAL

- (b) the temperature is uniform throughout the fuel droplet and equal to the boiling temperature.
- (c) the fuel droplet size changes slowly, therefore a steady state situation is assumed.
- (d) the fuel diffusivity is directly proportional to the evaporated fuel density.
- (e) the pressure is constant throughout the model and equals 1 atmosphere.

The fuel life time calculated by the equation developed for the single droplet is found to be close to the time measured by experimentation, ⁽¹⁰⁾ $\frac{\text{calculated}}{\text{experimental}} \times 100 = 97\%$.

The single droplet theory is modified to take into account the affect of the high combustion pressure developed in the EES chamber. The effect of the depletion of oxygen as combustion proceeds is found to be small and is neglected. The fuel life time expression thus modified is used to calculate the time required for complete combustion in the Alton chamber; $t_b = .045$ seconds. The actual fuel residence time calculated from experimental data is approximately .035 seconds. The calculated residence time predicts a combustion efficiency that is approximately 10% lower than that actually obtained with the EES chamber.

The following conditions not taken into account by the derivation are discussed in the report:

- (a) the fuel spray is composed of droplets of many sizes; the droplets larger than the mean tend to increase t_b ; those that are very small burn with the rapidity of premixed combustible gases which is so great that they, in effect, contribute nothing to the mean lifetime and could therefore be excluded.

(10) Godsave, S. A. E., Fourth Symposium on Combustion, Pg 818, Williams and Wilkins, Baltimore, 1953

- (b) the larger fuel droplets would be deformed by drag forces which would increase their burning rate by increasing their surface area, (increased evaporation rate).
- (c) the turbulent combustion caused by swirl vanes or baffles in the decomposition gases would decrease t_b .
- (d) because of the geometry of the central fuel nozzle spray in the Alton chamber a finite time delay exists until mixing conditions approaching stoichiometric are established.
- (e) the lack of internal circulation in the smaller fuel droplets promotes preferential vaporization of the lighter fuel fractions. This could lead to carbon formation and incomplete combustion.

The formula developed for t_b is used to compare the effect of the use of different fuels. Both the formula and test data from various literature sources show a definite gain in combustion efficiency in the modified Alton chamber would be attained if a lighter hydrocarbon fuel than the diesel oil were employed.

The formula also predicts a decrease in fuel droplet lifetime for smaller droplets. A comparison of various sized droplets was made during the tests at Becco and showed smaller droplets to yield inferior results. It might be expected that the increased velocity of fuel injection reduced the stay time in the short chamber at a faster rate than the life time was reduced by smaller droplets. As the effective length of the combustion zone in the Becco chamber was $1/4$ that of the modified Alton chamber, it could be expected that the efficiency would be lower than that experienced in the modified Alton chamber.

C

AJ

Best Available Copy