

UNCLASSIFIED



AD NUMBER

AD-061 751

CLASSIFICATION CHANGES

TO UNCLASSIFIED

FROM NEVER CLASSIFIED

AUTHORITY

OCA; Mar 1955

19990803/44

THIS PAGE IS UNCLASSIFIED

UNCLASSIFIED



AD NUMBER

**AD-061 751**

NEW LIMITATION CHANGE

TO

DISTRIBUTION STATEMENT: A

Approved for public release; Distribution is unlimited.

LIMITATION CODE: 1

FROM

No Prior DoD Distr Scty Cntrl St'mt Assgn'd

AUTHORITY

AFWAL Ltr; Apr 17, 1980 IAW DoDD 5200.20

THIS PAGE IS UNCLASSIFIED

119 617  
WADC TECHNICAL REPORT 55-124

# FORMATION LIGHTS FOR FIGHTER AIRCRAFT

CHARLES A. BAKER

AERO MEDICAL LABORATORY

MARCH 1955

Reproduced From  
Best Available Copy

WRIGHT AIR DEVELOPMENT CENTER

THIS REPORT HAS BEEN DELIMITED  
AND CLEARED FOR PUBLIC RELEASE  
UNDER DOD DIRECTIVE 5200.20 AND  
NO RESTRICTIONS ARE IMPOSED UPON  
ITS USE AND DISCLOSURE.

DISTRIBUTION STATEMENT A

APPROVED FOR PUBLIC RELEASE,  
DISTRIBUTION UNLIMITED.

# **FORMATION LIGHTS FOR FIGHTER AIRCRAFT**

**CHARLES A. BAKER**

**AERO MEDICAL LABORATORY**

**MARCH 1955**

**PROJECT No. 7180**

**WRIGHT AIR DEVELOPMENT CENTER  
AIR RESEARCH AND DEVELOPMENT COMMAND  
UNITED STATES AIR FORCE  
WRIGHT-PATTERSON AIR FORCE BASE, OHIO**

## FOREWORD

This report was prepared at the Psychology Branch, Aero Medical Laboratory, Directorate of Research, Wright Air Development Center, under Project No. 7180 entitled, "Human Engineering Application to Equipment Design," with Dr. Walter F. Grether acting as Project Engineer. The study of which this report is a summary was conducted at the request of Hq. Air Research and Development Command. Special acknowledgment is given to Lt. W. Dean Chiles for his valuable assistance in the preparation of the manuscript, and to Mrs. Edna Miller for her assistance in locating reference material.

ABSTRACT

An important consideration in the design of formation reference lighting on fighter aircraft is that the wing pilot should be provided with unambiguous information about the attitude and distance of the lead aircraft. The present formation lighting system used on fighter aircraft is inadequate in this respect, and, at least partially as a result of this, pilots frequently experience disorientation and confusion during night formation flight. The past research on formation lighting is reviewed and recommendations are made for modifications of the present formation lighting systems. These modifications utilize the conventional navigational lighting system components. The recommended modifications include: (1) redesign of the wing-tip navigation lights so that they provide suitable reference lighting for wing aircraft, (2) installation of a linear light on the fuselage near the wing root, and (3) the use of a single rotary detent control knob which provides control for three brightnesses of formation lights, navigation lighting for cruise and join-up, and an off position.

PUBLICATION REVIEW

This report has been reviewed and is approved.

FOR THE COMMANDER:

*Jack Bollerud, Colonel, USAF (MC)*  
JACK BOLLERUD

Colonel, USAF (MC)

Chief, Aero Medical Laboratory

Directorate of Research

	<u>Page</u>
Introduction.....	1
Design Considerations for Formation Lights.....	1
Present Status of Air Force Formation Lighting.....	2
Past Research on Formation Lighting.....	4
Recommended Formation Lighting Systems.....	6
Discussion.....	12
Summary.....	13
Bibliography.....	14

## LIST OF ILLUSTRATIONS

<u>Figure</u>	<u>Page</u>
1 Standard Exterior Lighting Installation.....	3
2 Alternative Methods for Wing Tip Formation Lighting.....	8
3 Recommended Exterior Lighting Arrangement.....	10
4 Recommended Exterior Lighting Control Knob.....	10

## LIST OF TABLES

<u>Table</u>	<u>Page</u>
I Table of Recommended Intensities.....	11



## I. INTRODUCTION

Formation flight of military aircraft is justified on the grounds of increased mission effectiveness, even though formation flight presents definite hazards to equipment and personnel. These hazards become greater when formation flight is conducted at night or in overcast where the visibility of other aircraft in the formation is restricted. One method of decreasing the hazards of night formation flight is to use exterior reference lighting on the aircraft. Such lights should be designed so that the wing pilot is able to maintain formation position with the least effort and confusion. The purpose of this report is to outline the type, color, intensity, arrangement, and control of formation lights that would most effectively reduce the hazards involved in night formation flight of fighter aircraft.

## II. DESIGN CONSIDERATIONS FOR FORMATION LIGHTS

The selection of any particular formation light system will depend upon many considerations; of these, the most basic are listed below. Of course, any satisfactory formation lighting system will of necessity consist of compromises among the various considerations.

### 1. Engineering considerations:

- (a) Aerodynamic factors of the exterior lighting installations.
- (b) Weight and space requirements of the lighting components.
- (c) Electrical demands and reliability of the lighting systems.

### 2. Security considerations:

- (a) Ground to air detection by the enemy.
- (b) Air to air detection by the enemy.

### 3. Human factors considerations:

- (a) Suitability in providing unambiguous orientation information.
- (b) Visibility of the reference lights.
- (c) Dark adaptation.
- (d) Comfort and fatigue.

In this report, the primary emphasis is upon the human factors considerations. However, the formation lighting systems recommended in this report are selected on the basis that they be compatible with the

engineering and security requirements as well as satisfy the human factors requirements. The recommendations must, of necessity, be general in nature because of the radical differences in airframe construction found among various types of fighter aircraft. For example, fighter aircraft are built with delta, with sweptback, or with straight wings. Also, some aircraft have wing tip tanks, or they may have rocket mounts. It is possible that the types of formation patterns flown will change as a function of the type of aircraft and its mission. Therefore, the design recommendations are kept general in order to permit their application to aircraft which vary widely in configuration.

### III. PRESENT STATUS OF AIR FORCE FORMATION LIGHTING

The formation light arrangement on current Air Force fighter aircraft is shown in Figure 1. These formation lights are the standard navigation lights switched to a dimmed position with a steady instead of flashing exposure. Therefore, the formation reference lighting consists of the wing tip running lights, the two fuselage section lights, and the two tail lights. These lights consist of filament bulbs protected by transparent shields which are faired into the aircraft surfaces. The lights thus give the appearance of "point" sources of light.

The important functional requirement of formation lighting is that it provide the pilot with unambiguous information about the attitude and distance of the lead aircraft. The present formation lights used by the Air Force are inadequate in this respect. Indeed, some of the instances of disorientation reported by pilots have been attributed to these lights (8, 16). The present formation lights may also account for some otherwise unexplained accidents (15). Previous evaluations of the present formation lighting system have reported it to be generally unsatisfactory (1, 12, 14), and other sources of information have indicated inadequacy. Personnel of the Aero Medical Laboratory, Wright Air Development Center, conducted an interview with fifteen pilots of the 97th Intercept Squadron. Eleven of the fifteen pilots reported that they had, on at least one occasion, become confused and disoriented during night formation flight. Several pilots reported that such disorientation occurred frequently, and most of the eleven pilots believed that the formation lights were the cause of the disorientation, or, at least, they believed that modifications of the formation light system would reduce the frequency of occurrence of disorientation. All fifteen of the pilots complained about the brightnesses of the formation lights (particularly the fuselage section lights), and most indicated a desire for a greater range of control of formation light brightnesses.

The disorientation that pilots experience during night formation flight may result from what is called the autokinetic illusion. The autokinetic illusion is a visual phenomenon in which a stationary spot of light against a dark background appears to move erratically. It is known to have been experienced by pilots when they were observing formation lights on other aircraft (8). In fact, this illusion can disorient a

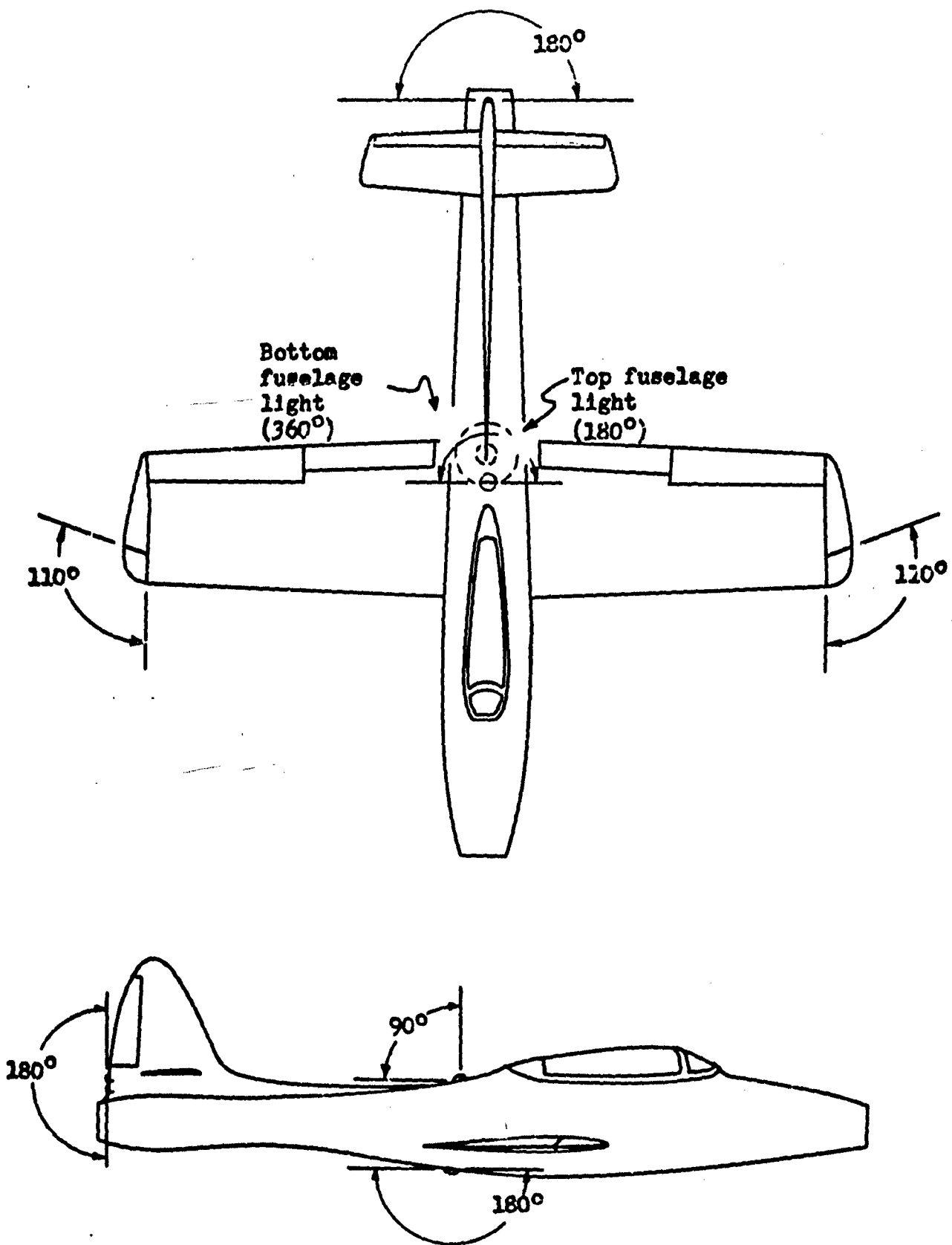

**FIGURE 1.** Standard exterior lighting installation. (MIL-L-6730)

trained pilot to the extent that he will spin in a Link trainer (8). In a recent night formation flight accident a surviving pilot reported that he "saw" the other two aircraft in the formation peel-off to the left when, actually, they had not changed course (16). On the basis of this false information he maneuvered his aircraft so as to collide with the other two with a resultant loss of one pilot and three F-86D aircraft. The "peeling-off" of these two aircraft is typical of the nature of the autokinetic illusion.

Investigations of the autokinetic illusion reveal that the apparent movement is greatest and most frequent when small (point-source), dim lights are being viewed; but it is still present in the case of large light sources (6, 7) and, although to a lesser degree, when viewing patterns of lights (8). Therefore, the use of more or larger area reference lights in formation flight should cause a reduction in the autokinetic effect. It has been demonstrated that autokinetic movement was frequent and large when only one reference light was visible during formation flight, was much reduced when two reference lights were visible, and reduced even more when three reference lights were visible (8).

In summary, it may be stated that the formation lights now used on Air Force fighter aircraft are inadequate, and, therefore, render night formation flight hazardous. Consequently, increased effort in the redesign of exterior reference lighting is needed.

#### IV. PAST RESEARCH ON FORMATION LIGHTING

In February, 1945, a conference was held at the Bureau of Medicine, Washington, D. C. for the purpose of discussing the possible causes of the great number of aircraft accidents which occur at night (15). The external lighting on aircraft during formation flight was considered to be a contributing factor in many accidents. The Navy, therefore, initiated a large program on external lighting on aircraft. Reports on the findings of this research program started appearing in 1945 and continued until 1949 (1, 2, 3, 5, 11, 12, 13). Most of the Navy's previous research is summarized in a single report in which the recommendations for exterior reference lighting can be found (3). The Air Force also conducted research on exterior formation lighting (9). Most of the data from these past investigations were obtained by pilot ratings in flight test programs; and additional data were obtained through laboratory research. The criteria which the pilots used in making their ratings were based on the adequacy of the lighting systems under investigation as an aid in maintaining orientation, that is, their usefulness as an indicator of the attitude and distance of the lead aircraft under various flight conditions, e.g., join up and formation flight on dark, overcast nights; moonlit nights; in overcast; etc. Also, the comfort and fatigue associated with the use of the various lighting systems were considered. A summary of the findings with respect to the variables studied is presented below.

## SUMMARY OF PREVIOUS RESEARCH

(1) Number of reference lights: With only one point-source reference light visible, the attitude of the lead aircraft is not discernable on dark nights; distance estimates are difficult; and autokinesis is severe. Therefore, a single point-source reference light was rated as being definitely undesirable. When two lights are visible, autokinesis is reduced, and aircraft attitude and distance estimates are improved providing that the two lights are strategically located. With three or more reference lights autokinesis is further reduced, and estimates of the aircraft attitude and distance are definitely improved if the three lights are strategically located.

(2) Location of the reference lights: The wing pilot desires to see the same detail of the lead aircraft that he sees in daytime flight. The wing position, juncture of the wing and fuselage, the tail, the nose, and the canopy give unambiguous information. The most satisfactory locations for formation reference lights are found to be (1) the tip or near the tip of the wing, (2) the fuselage near the juncture of the wing, and (3) the tail section of the aircraft. If these locations are used, three simultaneously visible reference lights appear to be the minimum number which will provide adequate information about the attitude and distance of the lead aircraft.

(3) Color of reference lights: Traditionally, the starboard wing light has been green and the port wing light has been red. Color coding has merit in that it assists in making the aircraft's heading apparent during rendezvous and join-up. However, since no systematic studies were conducted in which color was varied, little can be stated about this factor. For purposes of maintaining dark adaptation, red is preferred. However, during formation flight, because of the low intensities involved and the small visual angles subtended by the reference lights, the effects of color on dark adaptation are of little importance.

(4) Type of lighting:

a. Point sources: Point sources of light (filament bulbs with transparent covers) frequently present ambiguous cues for spatial orientation. Distance estimates of point sources of light are difficult, and reversals of apparent position occur, i.e., confusion as to which light stands for what section of the aircraft may occur. Even when many point sources of light are used, ambiguity may result under some conditions.

b. Flood lighting: Flood lighting the aircraft surfaces is an excellent method of providing orientation cues. This method of reference lighting provides excellent cues for join-up and for formation flight, even through overcast. The types of flood lighting investigated include flood illumination of the vertical

## SUMMARY OF PREVIOUS RESEARCH

(1) Number of reference lights: With only one point-source reference light visible, the attitude of the lead aircraft is not discernable on dark nights; distance estimates are difficult; and autokinesis is severe. Therefore, a single point-source reference light was rated as being definitely undesirable. When two lights are visible, autokinesis is reduced, and aircraft attitude and distance estimates are improved providing that the two lights are strategically located. With three or more reference lights autokinesis is further reduced, and estimates of the aircraft attitude and distance are definitely improved if the three lights are strategically located.

(2) Location of the reference lights: The wing pilot desires to see the same detail of the lead aircraft that he sees in daytime flight. The wing position, juncture of the wing and fuselage, the tail, the nose, and the canopy give unambiguous information. The most satisfactory locations for formation reference lights are found to be (1) the tip or near the tip of the wing, (2) the fuselage near the juncture of the wing, and (3) the tail section of the aircraft. If these locations are used, three simultaneously visible reference lights appear to be the minimum number which will provide adequate information about the attitude and distance of the lead aircraft.

(3) Color of reference lights: Traditionally, the starboard wing light has been green and the port wing light has been red. Color coding has merit in that it assists in making the aircraft's heading apparent during rendezvous and join-up. However, since no systematic studies were conducted in which color was varied, little can be stated about this factor. For purposes of maintaining dark adaptation, red is preferred. However, during formation flight, because of the low intensities involved and the small visual angles subtended by the reference lights, the effects of color on dark adaptation are of little importance.

### (4) Type of lighting:

a. Point sources: Point sources of light (filament bulbs with transparent covers) frequently present ambiguous cues for spatial orientation. Distance estimates of point sources of light are difficult, and reversals of apparent position occur, i.e., confusion as to which light stands for what section of the aircraft may occur. Even when many point sources of light are used, ambiguity may result under some conditions.

b. Flood lighting: Flood lighting the aircraft surfaces is an excellent method of providing orientation cues. This method of reference lighting provides excellent cues for join-up and for formation flight, even through overcast. The types of flood lighting investigated include flood illumination of the vertical

stabilizer, of the horizontal stabilizer, of the fuselage, and of the wing surfaces. Flood illumination of the vertical stabilizer was particularly liked by the test pilots. The installation of the light sources and the control of the light distribution produce many problems. Also, the weight and electrical demands of such lighting installations are much greater than those of the present lighting systems.

c. Linear lights: Linear lights give relatively unambiguous information. The solid surface appearance of extended light sources provides good distance and attitude cues. In this respect, these lights are superior to those which are point sources. Linear lighting systems are enthusiastically supported by experienced pilots who have observed them.

(5) Brightness of reference lights: During most night formation flight there is sufficient ambient illumination to see the silhouetted contours of the lead aircraft. In fact, on many moonlit nights the use of formation lights is not even necessary. In some cases the exhaust flame provides enough light to be of assistance. On moonless nights or under overcast, however, there is not sufficient ambient light for safe formation flight unless formation reference lighting is provided. The intensity of formation lights should be quite low. Pilots report that above certain minimum intensities the formation lights produce a glare, and the dim silhouette of the lead aircraft is no longer visible. Hence, important orientation cues are lost. The specific intensities and the control of these intensities for the various formation lights are shown page 11.

(6) Flashing versus steady lights: Steady lights are definitely preferred to flashing lights during formation flight. It was believed earlier that flashing lights were desirable because they reduce the autokinetic illusion, but later studies and test flights resulted in a definite preference for steady lights during formation flight.

On the basis of the past research on formation lights and interviews with operational fighter pilots and lighting engineers, several sound recommendations on the design of formation lights can be made. These recommendations are given in the following section.

#### V. RECOMMENDED FORMATION LIGHTING SYSTEMS

The recommendations that follow are largely based on the previous research discussed above. However, compromises were made in order to utilize the standard cross-country navigation lights now in use on fighter aircraft. As mentioned previously, the recommendations are general in nature in order that they can be applied to a wide variety of fighter aircraft.

(1) Location of formation lights: A minimum of three simultaneously visible reference lights are recommended. These reference lights should be located near; (a) the juncture of the aircraft wing and the fuselage, (b) the wing tip, and (c) the trailing edge of the tail surfaces. These lights should be located so that at least three are visible for any anticipated flight pattern.

(2) Types of Formation Lights:

a. Wing-tip lights: The wing-tip lights in current use on Air Force fighter aircraft are visible to wing aircraft pilots only because of scattered light from the plastic lamp cover. When the wing navigation lights are dimmed for formation flight, they provide a minimum of .001 candles in the direction of the wing aircraft (from  $110^{\circ}$  to  $170^{\circ}$  as specified in MIL-L-6503A). This intensity is minimally adequate for close formation flight. There are two objections to this type of wing-tip lighting for formation flight. One objection is that this light appears as a "point" source, though it should be noted that flight personnel do not consider this objection to be serious. The disadvantages of point source lighting were discussed above. The second objection concerns military security during formation flight. When in the dimmed position the wing-tip navigation lights emit approximately 0.4 candles over a fairly large area in front of the aircraft. These lights are visible from positions in front of the aircraft for a distance of over three miles under conditions of good visibility (4, 10). If these lights do not provide the security required by fighter aircraft, particularly for low altitude tactical fighter missions, a redesign will be required.

Two recommended modifications of the wing-tip reference lighting that would satisfy the requirements stated above are as follows:

1. The present wing-tip lights can be slightly modified so that they will provide sufficient formation reference lighting with a minimum emission of light forward of the aircraft. The present transparent cover of the wing-tip light extends from  $0^{\circ}$  to  $110^{\circ}$ . This is shown in Figure 2. It is recommended that this cover be extended to  $130^{\circ}$  or  $140^{\circ}$ . The cover portion from  $110^{\circ}$  to  $130^{\circ}$  or  $140^{\circ}$  should be a diffusing medium such as sandblasted plastic. The diffusing cover would provide a greater proportion of light in the direction of the wing aircraft. Therefore, during formation flight this fixture, even with a considerably reduced candle power output of the lamp, would provide sufficient light for the wing aircraft. Thus, less light will be emitted forward of the aircraft. Also, this fixture would appear more as an extended illuminated surface than as a point source of light.



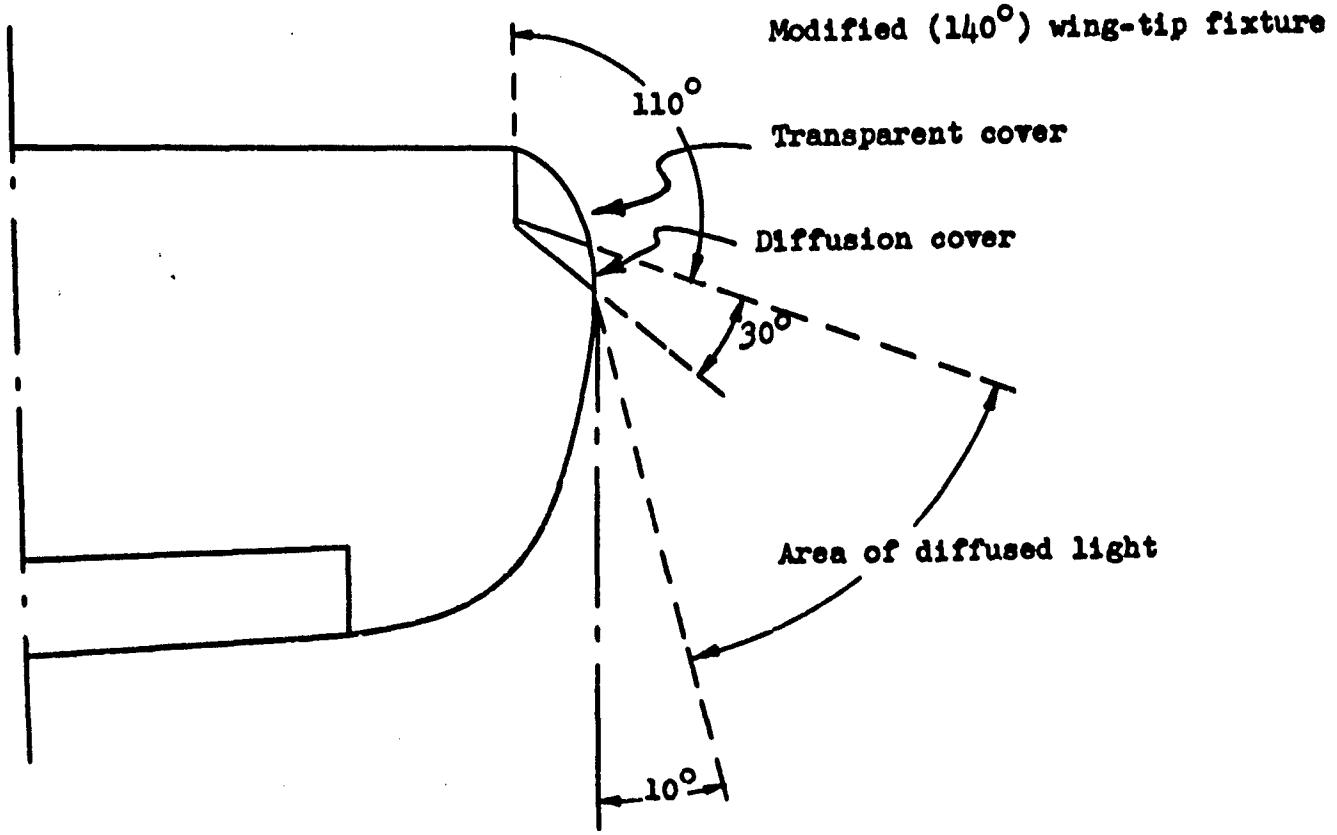
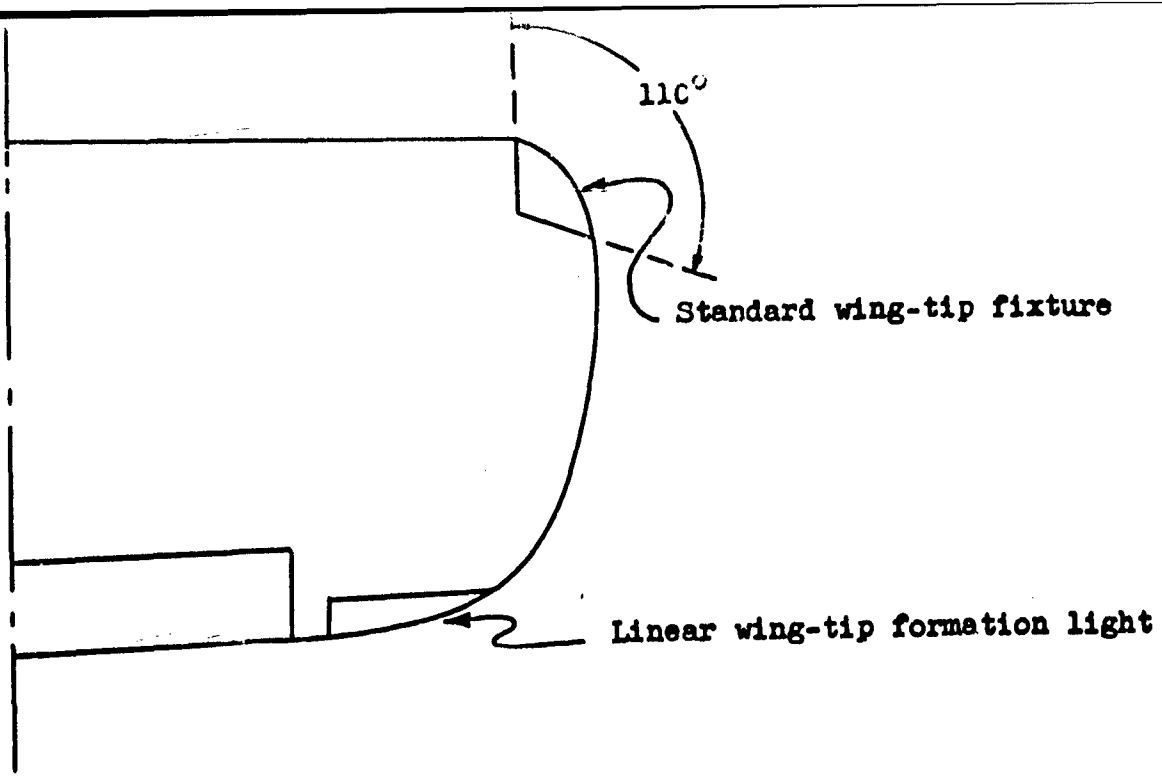

**FIGURE 2.** Recommended alternative methods for wing-tip formation lighting.

2. A second recommended solution is to provide a linear wing-tip trailing edge light. This reference light should have a minimum length of about five inches and minimum effective width of approximately 1/4 inches. Several shorter linear lights can be used in place of a single five inch fixture. Engineering installation of this type of fixture has been made for low performance aircraft (2). The use of the wing-tip trailing edge linear light is particularly recommended for use on those aircraft on which the thin wing construction does not permit installation of the wing-tip navigation light. See Figure 2 for an illustration of the principle of linear trailing edge reference lighting.

b. Fuselage linear lights: Flush mounted linear lights should be located at a distance of approximately one foot aft of the juncture of the wing and fuselage. (In some aircraft this distance should be increased so that the swept back wings or the tip tanks will not obscure the lighting fixture. On delta wing aircraft it may be necessary to have two such fixtures on each side of the fuselage, i.e., one above and one below the wing, in order that one will always be visible.) These fixtures should be about six to eight inches in length and about 1/2 to 1 inch in width. The fixture should be mounted parallel to the longitudinal axis of the aircraft and at about the same level as the wing root. The glass or plastic flush mounted cover should be sandblasted so that the emitted light is diffused. The general appearance of such a fixture is shown in Figure 3. See BuAir Drawing 203-G for details concerning a similar fixture used on the Navy FJ-3 aircraft.

c. Tail Formation lights: The type of tail reference formation lights specified in Mil-L-6503A is satisfactory. The brightnesses and control of brightnesses of the tail reference lights, however, have been modified in the recommendations that appear below.

Floodlighting of the vertical stabilizer is recommended for training aircraft in which night formation flight is conducted by relatively inexperienced pilots. The frequency of night training accidents is sufficiently high to justify the application of this method of formation lighting to training aircraft. Previous reports on external flood lighting should be consulted (9, 11). Strips of reflective and diffusing material, such as painted emblems, placed on the vertical stabilizer will increase the effectiveness of the floodlighting.

d. Section fuselage lights: The "turtleback" fuselage lights, specified in Mil-L-6503A are satisfactory. The brightnesses and the control of these brightnesses are discussed below.

(3) Brightness of formation lights: The brightnesses of formation lights and the control of these brightnesses are summarized in Table 1 below.

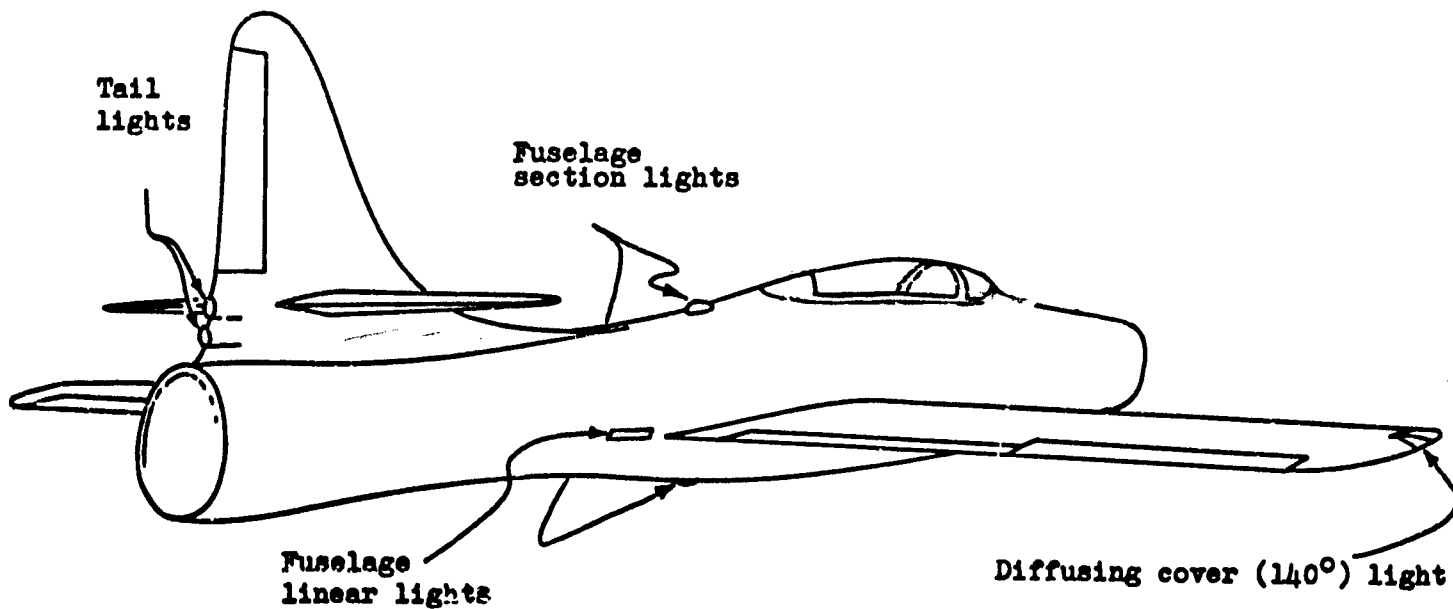

**FIGURE 3.** Recommended exterior lighting arrangement.

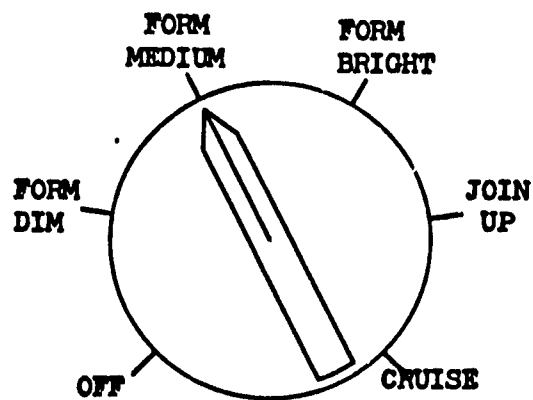

**FIGURE 4.** Recommended exterior lighting control knob.

TABLE 1.

		Formation Lights**				
		Cruise*	Join-Up	Bright	Medium	Dim
1	0° to 110° navigation light (Standard fixture)	flashing 24 CP	flashing 24 CP	flashing 24 CP	OFF	OFF
	Trailing Edge linear light (See text of report)	OFF	Steady 3 Ft.L.	Steady 3 Ft.L.	Steady .5 Ft.L.	Steady .05 Ft.L.
2	0° to 140° navigation light (Intensities for 0° to 110°)	flashing 24 CP	flashing 24 CP	flashing 24 CP	Steady ?***	Steady ?
	0° to 140° navigation light (Intensities for 110°-140°)	flashing ?	flashing ?	flashing ?	Steady .01 C	Steady .001 C
Fuselage Section lights		Steady 50 CP	Steady 50 CP	Steady 1 C	Steady .01 C	OFF
Tail lights		flashing 32 CP	Flashing 32 CP	Steady 1 C	Steady .01 C	Steady .001 C
Fuselage linear lights		OFF	Steady 3 Ft.L.	Steady 3 Ft.L.	Steady .5 Ft.L.	Steady .05 Ft.L.
Vertical stabilizer flood lights (Trainer aircraft)		OFF	Steady 5 Ft.C.	Steady 5 Ft.C.	Steady 1 Ft.C.	OFF

\* The candlepower (CP) values for the cruise condition comply with MIL-L-6503A, 18 March 1954.

\*\* The light intensities in candles (C) should be determined with respect to the position of the wing aircraft (distances irrelevant) to the lead aircraft. When various formation flight patterns are anticipated these values refer to the average intensities for these various positions. In no case should they vary by more than a factor of ten from the recommended intensities. The light intensities in Foot Lamberts (Ft.L.) refer to the brightness of the surface when viewed from the position of the wing aircraft when in formation. The intensities in foot candles (Ft. C.) refer to the average illumination on the vortical stabilizer surface.

\*\*\* The actual value now represented by the question mark (?) will depend upon transmission characteristics of the 1400 wing-tip fixture.

(4) Color of formation lights: The reference lights on the starboard wing tip should be green; the reference lights on the port wing tip should be red; the section lights should be white; and the tail lights should be white and amber to comply with Mil-L-6503A. The fuselage linear lights should be amber.

(5) Control of exterior reference lights: The recommended design of the control for the exterior lights is shown in Figure 4. The control knob should be designed so that a stop prohibits turning the knob past the "off" position when turned counterclockwise, and another stop prohibits turning the knob past the "cruise" position when rotated clockwise. The advantages of this type of control are:

a. A single control is used to select six conditions of external lighting, thus simplifying the pilot's task. These six lighting conditions are Dim, Medium, and Bright Formation, Join Up, Cruise, and Off.

b. The control is designed so that its position can be determined tactually by the pilot and, therefore, does not require visual monitoring.

c. The three settings of the formation lights provide for a wide range of flight conditions. The "Bright" setting provides adequate reference lighting for formation flight and also maintains the wing tip navigation lights at the cruise intensity. This provides for cross country formation flight where it is desired that other aircraft be alerted. The "Medium" setting is designed for standard conditions during formation flight. The "Dim" setting is designed to provide military security during formation flight. Also, the "Dim" position is desirable for formation flight on very dark nights when glare of brighter lighting would make invisible the dim silhouette of the lead aircraft.

## VI. DISCUSSION

The scope of this report is limited to the external lighting used on fighter aircraft in formation flight. No attempt was made to investigate or alter the design of the navigation lights which has been determined by convention and international agreement. In an effort to minimize the complexity of the external lighting systems on fighter aircraft the conventional navigation lighting system components are utilized for formation reference lighting. Therefore, the formation lighting system recommended in this report requires relatively few modifications of the present external lighting systems. The modifications recommended are:

(1) Redesign of the wing tip navigation lights so that they are visible to wing aircraft without violating military security. If this is not feasible for particular aircraft an additional linear wing tip trailing edge lighting fixture should be installed.

(2) The installation of a linear light on the fuselage near the wing root.

(3) A single rotary detent control knob to control the external lighting. This control provides three brightness positions for formation lighting as well as cruise, join up, and an off position.

(4) In training aircraft in which night formation flight is conducted by relatively inexperienced pilots, flood lighting of the vertical stabilizer is recommended. This type of formation lighting provides excellent cues for join-up and for formation flight.

The intensities recommended for exterior lights are shown in Table 1. These intensities should be tested in a flight test program before they are finally accepted as Air Force Specifications.

## VII. SUMMARY

This report has dealt with the design of external lighting for use in formation flight at night in fighter aircraft. The recommendations made are based primarily on previous research on formation lights and on interviews with operational all-weather fighter pilots and lighting engineers. The standard navigation light system was incorporated into the formation light system in order to minimize the complexity and number of modifications required. It is believed that the recommendations contained in this report will overcome the major objections to the formation lighting systems presently used on fighter aircraft.

## VIII REFERENCES

1. Blasdel, I. Study of exterior lighting for Navy airplanes. Field observation by Composite Squadron Four. NAES Topical Report XG-T-119, TED No. 31333, May, 1945.
2. Blasdel, I. C. and Lazo, J. Study of exterior lighting for Navy airplanes. Report No. 5. The installation of lights on the trailing edge of wings for low level illumination of aircraft. NAES Report TED No. NAM 31333, No. 5, May, 1949.
3. Blasdel, I. C. and Lazo, J. Study of exterior lighting for Naval airplanes. Report No. 6. Night flight tests of experimental exterior lighting systems on military aircraft. NAES Report TED No. NAM 31333, No. 6, June, 1949.
4. Bouma, P. J. Illumination and black-outs. Phillips Tech. Rev., 1939, 4, 15-19.
5. Bromer, J. and Orlansky, J. Preliminary report on investigation of exterior lighting equipment. NAES Report TED No. NAM 31333, August, 1945.
6. Edwards, W. Two and three-dimensional autokinetic movement as a function of size and brightness of stimuli. J. exp. Psychol., 1954, 48, 391-398.
7. Edwards, W. Autokinetic movements of very large stimuli. J. Exp. Psychol., 1954, 48, 493-495.
8. Graybiel, A. and Clark, B. The autokinetic illusion and its significance in night flying. Project No. X-148 (Av-V4-3), Report No. 3, Naval School of Aviation Medicine, Pensacola, Florida, February, 1945.
9. Grave, C. Engineering and development test of exterior lighting requirements. Project No. 3-46-5, The Air Proving Ground Command, Eglin Field, Florida, May, 1947.
10. Knoll, H. A., Tousey, R., and Hulbert, E. O. Visual thresholds of steady point sources of light in fields of brightnesses from dark to daylight. J. opt. Soc. Amer., 1946, 36, 480-482.
11. Orlansky, J. Report of exterior lighting for Navy airplanes. Report No. 2. The use of floodlights for the exterior lighting of naval aircraft. NAES Report TED No. NAM 31333, No. 2, June, 1946.

12. Orlansky, J. Study of exterior lighting for Navy airplanes. Report No. 3. Flight tests of some exterior lighting systems to facilitate rendezvous and formation flying of naval aircraft at night. NAES Report TED No. NAM 31333, No. 3, July, 1946.
13. Wagner, H. G., Blasdel, I. C., and Lazo, J. Study of exterior lighting for Navy airplanes. Report No. 4. A method of exterior aircraft illumination using transparent acrylic plastic. NAES Report TED No. NAM 31333, No. 4, February, 1949.
14. Walker, E. L. Investigation of visual factors contributing to night aircraft accidents with special reference to methods of lighting planes. BuMed Project X-498 (Av0265-P) Report No. 2, Corpus Christi, October, 1945.
15. Minutes on conference on the external lighting of aircraft and disorientation during night flying. Conference at BuMed, Navy Department, 14 and 15 February 1945.
16. Report of special investigation of major aircraft accident involving three F-86D aircraft. Office of the Inspector General, Norton Air Force Base, California, 29 December 1954.