

UNCLASSIFIED

AD NUMBER
AD030598
NEW LIMITATION CHANGE
TO Approved for public release, distribution unlimited
FROM Distribution authorized to U.S. Gov't. agencies and their contractors; Administrative/Operational Use; MAY 1954. Other requests shall be referred to National Aeronautics and Space Administration, Washington, Dc.
AUTHORITY
NASA TR Server website

THIS PAGE IS UNCLASSIFIED

Armed Services Technical Information Agency

Because of our limited supply, you are requested to return this copy WHEN IT HAS SERVED YOUR PURPOSE so that it may be made available to other requesters. Your cooperation will be appreciated.

AD

30598

NOTICE: WHEN GOVERNMENT OR OTHER DRAWINGS, SPECIFICATIONS OR OTHER DATA ARE USED FOR ANY PURPOSE OTHER THAN IN CONNECTION WITH A DEFINITELY RELATED GOVERNMENT PROCUREMENT OPERATION, THE U. S. GOVERNMENT THEREBY INCURS NO RESPONSIBILITY, NOR ANY OBLIGATION WHATSOEVER; AND THE FACT THAT THE GOVERNMENT MAY HAVE FORMULATED, FURNISHED, OR IN ANY WAY SUPPLIED THE SAID DRAWINGS, SPECIFICATIONS, OR OTHER DATA IS NOT TO BE REGARDED BY IMPLICATION OR OTHERWISE AS IN ANY MANNER LICENSING THE HOLDER OR ANY OTHER PERSON OR CORPORATION, OR CONVEYING ANY RIGHTS OR PERMISSION TO MANUFACTURE, USE OR SELL ANY PATENTED INVENTION THAT MAY IN ANY WAY BE RELATED THERETO.

Reproduced by
DOCUMENT SERVICE CENTER
KNOTT BUILDING, DAYTON, 2, OHIO

UNCLASSIFIED

NACA TN 3186

AD No. 905-98

ASTIA FILE COPY

NATIONAL ADVISORY COMMITTEE
FOR AERONAUTICS

TECHNICAL NOTE 3186

EVALUATION OF THE ACCURACY OF AN AIRCRAFT
RADIO ALTIMETER FOR USE IN A METHOD
OF AIRSPEED CALIBRATION

By Jim Rogers Thompson and Max C. Kurbjun

Langley Aeronautical Laboratory
Langley Field, Va.



Washington

May 1954

L

NATIONAL ADVISORY COMMITTEE FOR AERONAUTICS

TECHNICAL NOTE 3186

EVALUATION OF THE ACCURACY OF AN AIRCRAFT
RADIO ALTIMETER FOR USE IN A METHOD
OF AIRSPEED CALIBRATION

By Jim Rogers Thompson and Max C. Kurbjun

SUMMARY

The accuracy of an aircraft radio altimeter has been evaluated for use in a method of airspeed calibration differing from the radar-phototheodolite method of NACA Rep. 985 only in that the geometric altitude is obtained from an aircraft radio altimeter. The accuracy of the radio altimeter used (SCR-718-C) was found to be of the same order as that of the NACA radar phototheodolite unit during simulated calibration maneuvers; thus, the accuracy of airspeed calibrations by the two methods should be similar.

It is believed that the method provides a rapid and convenient means for calibrating the airspeed systems of high-performance aircraft. The method has the disadvantage that the tests must be performed over a large body of water.

INTRODUCTION

The advent of aircraft that attain their maximum performance at high altitudes and the irregularities common to many types of airspeed installations at transonic speeds have combined to render inadequate for such aircraft the methods of airspeed calibration described in reference 1. The radar method, presented in reference 2, provides an adequate solution of the problem but requires complicated and expensive fixed ground equipment which is not generally available. It also requires laborious calculations for the data reduction and limits testing to excellent visibility conditions in a small fixed area. More recently, two methods of airspeed calibration have been investigated which utilize measurements of temperature and longitudinal acceleration, respectively. These methods, which are described in references 3 and 4, have the advantage of allowing all the necessary equipment to be placed within the test airplane but have the disadvantage of requiring extremely sensitive instruments which may not be generally available. The method of

reference 4 also places restrictions on the airplane flight path and that of reference 3 requires the existence of atmospheric conditions which occur infrequently.

The purpose of the present paper is to evaluate the accuracy of an aircraft radio altimeter for use in a method of airspeed calibration differing from the radar method of reference 2 only in that the geometric altitude is measured by an aircraft radio altimeter rather than by a ground radar tracking installation. The method has the obvious advantages that the necessary equipment is readily available and is completely contained within the airplane, and the desired quantity is measured directly. The method also has the obvious disadvantage that a level ground reference plane is required, with the result that the application of the method is effectively restricted to flight over large bodies of water. Of course, both methods require the knowledge of at least one point on the airspeed calibration (preferably at a suitable climbing speed) which is usually obtained by the method of reference 1.

The evaluation of the method presented herein is based on the results of flight tests in which the altitude indicated by an aircraft radio altimeter was compared with that given by the NACA radar phototheodolite unit for a wide range of flight conditions which are thought to include those that would be encountered in an airspeed calibration of a transonic airplane.

EQUIPMENT AND MEASUREMENTS

Aircraft radio altimeter.- An aircraft radio altimeter, AN type SCR-718-C, was used in the tests reported herein. The basic SCR-718 unit was developed early in World War II and has been extensively used by the military services. This altimeter is a pulse type operating at a frequency of about 440 megacycles and having a nominal range of 0 to 50,000 feet. The geometric altitude is indicated by a pulse appearing on a circular trace on the face of a cathode-ray tube. The system is arranged so that one revolution of the altitude pulse corresponds to a change in altitude of 5,000 feet. A switching arrangement is provided to reduce the scale by a factor of 10 (that is, one revolution for 50,000 feet); however, this provision is seldom used in practice and was not used in the tests reported herein. The only modifications made to the altimeter system were the addition of a reference scale to the gain control (so that settings could be repeated accurately) and replacement of the green indicator tube with a blue one for photographic reasons.

Installation of radio altimeter.- The radio altimeter was installed in a two-place fighter-type airplane in accordance with the recommendations of reference 5. The indicator unit (about 7 by 7 by 13 inches,

10 pounds) was mounted in front of the copilot's instrument panel as shown in figure 1 so that it could be observed during the tests. An aircraft gun camera was mounted above the copilot's left shoulder to photograph the indicator. Because of the high light level prevalent in the cockpit, a removable tubular shield was provided between the camera and indicator (not shown in fig. 1).

The transmitter-receiver unit (about 8 by 9 by 16 inches, 12 pounds) was mounted in the radio compartment. The remaining pieces of equipment required, the transmitting and receiving antennas, were mounted on the lower surface of the right fuselage (fig. 2). This installation (antennas in line) was selected from reference 5 as being the most convenient for the airplane used.

Instrumentation.- The airplane was fitted with standard NACA recording instruments measuring total and static pressures at the pitot-static tube, normal acceleration, pitch angle, bank angle, and free-air temperature. These instruments were synchronized with each other and with the camera photographing the radio-altimeter indicator by means of a common timing circuit. Timing signals were also transmitted by radio to the NACA radar phototheodolite unit for synchronization of the ground and airplane data. The NACA radar phototheodolite, which consists of an SCR-584 radar aircraft tracking unit modified by the addition of fixed azimuth and elevator scales, a long-focal-length target camera, and a photographic recording system is described in reference 2.

TEST PROCEDURE

The flight program was selected to duplicate the calibration procedure recommended in reference 2 and, in addition, to include conditions which might be critical for the radio altimeter. The principal factors which might affect the accuracy of the radio altimeter are the pitch and roll attitudes (because of the directional characteristics of the antenna system), the receiver gain setting, and the zero setting.

The flight program was as follows:

(1) During climb, pressure-survey points were recorded at 500-foot intervals from 500 to 20,000 feet and at 1,000-foot intervals from 20,000 to 30,000 feet.

(2) Windup-turn maneuvers starting at 29,000 feet were performed to attain bank angles approaching 90° and push-down, pull-up, push-down maneuvers were performed to reach steep dive and climb attitudes.

(3) In a manner similar to item (1), pressure-survey points were recorded in a descent to 15,000 feet.

(4) Maneuvers similar to those in item (2) were repeated at 14,000 feet and, in addition, a series of level runs were made at different gain settings.

(5) In a descent to 500 feet, pressure-survey points were recorded at 1,000-foot intervals.

The radio altimeter was operated in accordance with the recommendations of reference 5 except for the gain control setting. Items (1), (3), and (5) and one run of each type in items (2) and (4) were performed at "normal" gain (that is, the gain required to produce an altitude signal pip about 0.25 inch high). The remaining runs of items (2) and (4) were performed at different gain settings from normal in order to establish the effect of gain setting. The transmitter output and receiver sensitivity were checked before and after flight by the procedure recommended in reference 5 and were found to be within the limits there specified.

The flight tests were performed over the Atlantic Ocean to the southeast of the radar phototheodolite unit of the Langley Pilotless Aircraft Research Station at Wallops Island, Va.

DATA REDUCTION AND RESULTS

The variation of geometric altitude with time during each of the test runs was established by fairing the altitude obtained from the radar phototheodolite unit in a manner consistent with the accelerations recorded in the airplane. The radar-phototheodolite data were corrected as recommended in reference 2 for atmospheric refraction, the curvature of the earth, and the elevation of the unit above mean sea level. Approximately 90 percent of the individual points (which were taken at 1-second intervals) differed from the fairing by less than 20 feet. The nominal maximum uncertainty of each radar-phototheodolite point for the average conditions encountered is given by reference 2 as about ± 40 feet.

The indications of the radio altimeter were read at intervals of about $1/2$ second throughout each run from a projection of the photograph slightly larger than the actual size of the instrument. A tracing of a typical photograph is presented as figure 3. As the scale graduations on the face of the tube do not show in the photographs and in order to correct for errors in centering the indicating circle on the scale, it is convenient to read the altitude by means of a movable transparent grid marked with the scale and with several concentric circles. The grid (also shown in fig. 3) is centered on the circular trace through use of the concentric circles with the zero mark at the point of emergence of the reference pulse. The indicated altitude is read on the

scale at the point of emergence of the altitude pulse. This procedure automatically accounts for any drift of the reference pulse which might occur; however, in the present tests (and in other unreported tests in which the instrument was used) no drift of the reference pulse was observed. The height of the altitude pulse (an indication of the received signal strength) was also measured for most of the runs.

The difference between the indication of the radio altimeter and the value of geometric altitude taken from the fairing of the radar-phototheodolite data at the same time is hereinafter considered to be the error of the radio altimeter. The ensemble of error values thus determined is presented in statistical form in table I, together with pertinent flight conditions for each run.

DISCUSSION

Accuracy of radio altimeter during pressure survey and in level flight.- The results given in table I for the pressure-survey and level-flight runs show values of mean error \bar{X} ranging from -25 to 42 feet with standard deviations ranging up to 30 feet. Both values are slightly larger for the pressure-survey points than for the level runs, possibly because of the fact that each of the survey points was based on a single radar-phototheodolite reading rather than on a fairing of several readings as was the case in the latter runs.

The accuracy for the radio altimeter, as indicated in reference 5 and other sources, is ± 25 feet ± 0.25 percent of the indicated altitude. The pressure-survey data are compared with these limits in figure 4, which shows the variation of the altimeter error with indicated altitude. Although the error is consistently positive ($\bar{X} = 42$ feet), it is evident that there is no consistent trend of the error with altitude and that over 75 percent of the points lie within the specified range. If the limits are applied about the mean value, 93 percent of the points lie within the specified range.

Effect of gain setting.- Reference 5 recommends that the gain be adjusted so that the altitude pip is about 0.25 inch high (see fig. 3). The amount of gain required to fulfill this condition is shown in figure 5 as a function of altitude. (The gain-control scale is arbitrary, zero corresponding to off and 10 to maximum gain.) The values of mean error and standard deviation given in table I do not show significant variations when runs differing only in gain setting are compared. It is therefore concluded that, within the accuracy of these measurements, the error of the radio altimeter is unaffected by the gain setting provided that sufficient gain is used to produce a readable altitude pulse. In the opinion of the authors, the point of emergence of a large signal may be read more easily and accurately than that of a small signal.

Effect of airplane attitude.- Examination of table I reveals that, at normal gain settings, the altimeter gives readable signals up to attitude angles of about 80° roll and 40° pitch. The altimeter errors given in table I show that the mean error and standard deviation are only slightly decreased when the data are restricted to a limited angle range. This result confirms the statement made in the previous section that the error is practically independent of the gain setting (or signal strength). The signal strength does tend to decrease with increasing bank or pitch angle, however, and, in the case of the pull-up, push-down maneuvers, reaches such a low value that the signals become unreadable. In both the bank and pitch cases, the signal strength at high angles is markedly increased by an increase in gain setting so that the desirability of operating the equipment at a high gain is indicated.

The result that the angular limit in roll is higher than that in pitch is predicted by simple antenna theory. Theory indicates that for an isolated dipole the signal strength is constant perpendicular to the axis (roll direction for present installation) and decreases to zero as the axial direction is approached. The airplane surface on which the antenna is mounted, however, serves as a reflector and (for proper spacing) doubles the signal strength in the direction normal to the reflector, leaves the signal strength unchanged on the sides, and reduces it to zero behind the reflector. Reference 5 recommends that the antenna be installed on flat surfaces at least 2 feet square. The bottom of the fuselage on which the antennas were installed for the present tests is considerably narrower than the recommended value and is sharply curved away from the antennas. Thus, the performance of the present installation is probably less than optimum.

Estimated accuracy of airspeed calibration.- The preceding material indicates that the arithmetic mean of the altimeter error for the several flights scatters within about 40 feet and the standard deviation of the individual points of each run is about 30 feet. These errors are only slightly greater than those to be expected from the radar phototheodolite unit (see ref. 2); thus, the accuracy of calibrations made by the two methods should be of the same order. It should be noted, however, that the error of the airspeed calibration is not dependent on the absolute accuracy of the geometric altitude but on the repeatability of the altitude indication between the survey and the test run. The repeatability is indicated in these data by the scatter of the arithmetic means. A large part of the errors associated with the standard-deviation values given may be removed from the final calibration by fairing if sufficient data are available.

The accuracy of the airspeed calibration is, of course, also a function of the accuracy of the pressure instrument used. For example, the accuracy of conventional pressure recorders is usually estimated to

be of the order of 0.25 percent of full scale which, for a full-range instrument, corresponds to about 1 inch of water. This pressure uncertainty corresponds to about 110 feet at an altitude of 15,000 feet and about 180 feet at an altitude of 30,000 feet. These values are the absolute uncertainties; however, as in the case of the geometric altitude, the calibration uncertainty depends only on the repeatability, which is somewhat less than the absolute uncertainty. The effect of the pressure uncertainty for the example given is larger than that of the geometric-altitude uncertainty by an amount which increases rapidly as the altitude is increased. Use of more accurate pressure instruments will, of course, increase the altitude at which the errors are of the same order; however, the trend of the respective errors with altitude will remain the same.

It should be noted that, for variations of the method of reference 2 in which the survey is obtained by other means (for example, radiosonde), the absolute accuracies of both sets of pressure and geometric-altitude instruments are involved rather than the repeatability of one set of instruments. Obviously, much more accurate instruments must be used both in the airplane and for the survey device in order to obtain a calibration of accuracy comparable with that obtained when the survey is made by the test airplane.

The accuracy of an airspeed calibration based on measurements of pressure and geometric altitude increases rapidly with an increase in speed. At 30,000 feet, an altitude error of 40 feet corresponds to an error of 1 percent of dynamic pressure at a Mach number of 0.5, 0.25 percent at a Mach number of 1, and 0.11 percent at a Mach number of 1.5. Thus, the method appears to be most useful at high speeds.

Application.- In the tests reported herein, the altimeter used was mounted in the copilot's cockpit in order that the operation of the equipment might be monitored and the gain control adjusted. The results showed that use of gain settings higher than recommended did not affect the accuracy and increased the angular limits of operation of the instrument and that adjustments in flight were not required. Thus, the instruments could be mounted in any convenient location and would not require the attention of the pilot or require the installation of additional equipment in an already crowded cockpit when used in single-seat aircraft.

The angular limits established in the present tests (table I) are believed to be representative of performance attainable with conventional installations. At higher altitudes than those investigated (where high nominal gains are required), the angular ranges would be reduced, but with careful planning almost all the useful performance range of the airplane could be investigated. If higher angular ranges were desired for special purposes, the useful ranges could be changed by reorientation

of the antenna system. For example, the angular ranges in roll and pitch could be interchanged by locating the antennas so that the long axis was perpendicular to rather than parallel to the flight direction.

The reference pulse (see fig. 3) is stationary and, between readings of 0 and about 500 feet, obscures the altitude pulse. This range should be avoided in scheduling level or nearly level runs. For extended dives or climbs which cover more than 5,000 feet, the data may be faired across the unreadable region.

Reference 5 gives the maximum range of the SCR-718 altimeter as 50,000 feet but states that it should not be operated above 45,000 feet unless pressurization is provided. The SCR-718 altimeter was developed about 10 years ago; since that time, altimeters having greater ranges and improved accuracies and sensitivities have been developed by or for the military services. It is considered that organizations calibrating airplanes capable of exceeding the useful range of the subject instrument would have available to them the more recent models.

CONCLUDING REMARKS

The accuracy of an aircraft radio altimeter has been evaluated for use in a method of airspeed calibration differing from the radar-phototheodolite method of NACA Rep. 985 only in that the geometric altitude is obtained from an aircraft radio altimeter. Comparison of geometric altitudes indicated by an SCR-718-C aircraft radio altimeter with measurements made by the NACA radar phototheodolite unit during simulated calibration runs showed that the accuracy of the radio altimeter was of the same order as that of the radar phototheodolite unit; thus, calibrations of comparable accuracy could be expected.

At normal gain settings, the altimeter gave readable signals up to attitude angles of about $\pm 80^\circ$ roll and $\pm 40^\circ$ pitch. These angular limits and the readability of the signals were markedly improved by operation at higher than normal gain settings. Use of high gain settings did not affect the accuracy of the altimeter. The results indicated that the instrument did not require adjustment during flight and, if the gain was set to a high value, could be mounted away from the cockpit and used as a recording instrument.

Inasmuch as in the proposed method all the necessary equipment is contained within the airplane, the desired quantity is measured directly and requires a minimum of calculations for the data reduction, the tests are not restricted to a small area or excellent visibility conditions, and the equipment required is readily available, it is believed that the method provides a rapid and convenient means for calibrating the airspeed

system of high-performance aircraft. The method has the disadvantage that the tests must be performed over a large body of water.

Langley Aeronautical Laboratory,
National Advisory Committee for Aeronautics,
Langley Field Va., February 25, 1954.

REFERENCES

1. Huston, Wilber B.: Accuracy of Airspeed Measurements and Flight Calibration Procedures. NACA Rep. 919, 1948. (Supersedes NACA TN 1605.)
2. Zalovcik, John A.: A Radar Method of Calibrating Airspeed Installations on Airplanes in Maneuvers at High Altitudes and at Transonic and Supersonic Speeds. NACA Rep. 985, 1950. (Supersedes NACA TN 1979.)
3. Lina, Lindsay J., and Ricker, Harry H., Jr.: Measurements of Temperature Variations in the Atmosphere Near the Tropopause With Reference to Airspeed Calibration by the Temperature Method. NACA TN 2807, 1952.
4. Lina, Lindsay J., and Trant, James P., Jr.: Comparison of Airspeed Calibrations Evaluated by the Accelerometer and Radar Methods. NACA TN 2570, 1952.
5. Anon.: Handbook Maintenance Instructions - Radio Sets SCR-718-A, SCR-718-AM, SCR-718-B, and SCR-718-C. AN 16-40SCR718-3, USAF and Bur. Aero., Nov. 4, 1944 (Rev. Nov. 14, 1951).

TABLE I.- ALTIMETER ERRORS AND ASSOCIATED FLIGHT CONDITIONS

Altitude, ft	Gain setting	Maximum attitude angle attained, deg	Limit angle for signal, deg	Altimeter errors												Type of run or maneuver		
				All points			Points below 60°			Points below 40°			Number of points	Mean \bar{x} , ft	Standard deviation, σ , ft			
				Number of points	Mean error, \bar{x} , ft	Standard deviation, σ , ft	Number of points	Mean error, \bar{x} , ft	Standard deviation, σ , ft	Number of points	Mean error, \bar{x} , ft	Standard deviation, σ , ft						
0-30.0 x 10 ³	Nominal (fig. 5)																	
14	2	-----	---	72	42	30	--	---	---	---	--	---	---	---	--	---	---	Pressure survey
14	4	-----	---	14	4	10	--	---	---	---	--	---	---	---	--	---	---	Level flight
14	6	-----	---	15	24	27	--	---	---	---	--	---	---	---	--	---	---	Level flight
14	8	-----	---	14	-25	6	--	---	---	---	--	---	---	---	--	---	---	Level flight
14	10	-----	---	13	-15	4	--	---	---	---	--	---	---	---	--	---	---	Level flight
14	3.5	75 (bank)	>75	15	1	12	--	---	---	---	--	---	---	---	--	---	---	Level flight
29	5.5	73 (bank)	>73	94	8	34	68	2	24	2	24	2	24	2	24	2	24	Windup-turn maneuvers
29	9	84 (bank)	>84	59	9	26	36	2	23	2	23	2	23	2	23	2	23	Windup-turn maneuvers
14	3	83 (bank)	>83	84	-24	22	60	-19	11	11	11	11	11	11	11	11	11	Windup-turn maneuvers
29	5.5	-48 (pitch) 73 (pitch)	-35 45	80	38	23	56	30	20	20	20	20	20	20	20	20	20	Windup-turn maneuvers
14	3	-62 (pitch) 72 (pitch)	-40 50	74	-7	29	--	---	---	---	--	---	---	---	--	---	---	Pull-up, push-down maneuvers
14	6	-59 (pitch) 77 (pitch)	-50 70	102	28	34	--	---	---	---	--	---	---	---	--	---	---	Pull-up, push-down maneuvers
14	6			128	7	29	--	---	---	---	--	---	---	---	--	---	---	Pull-up, push-down maneuvers

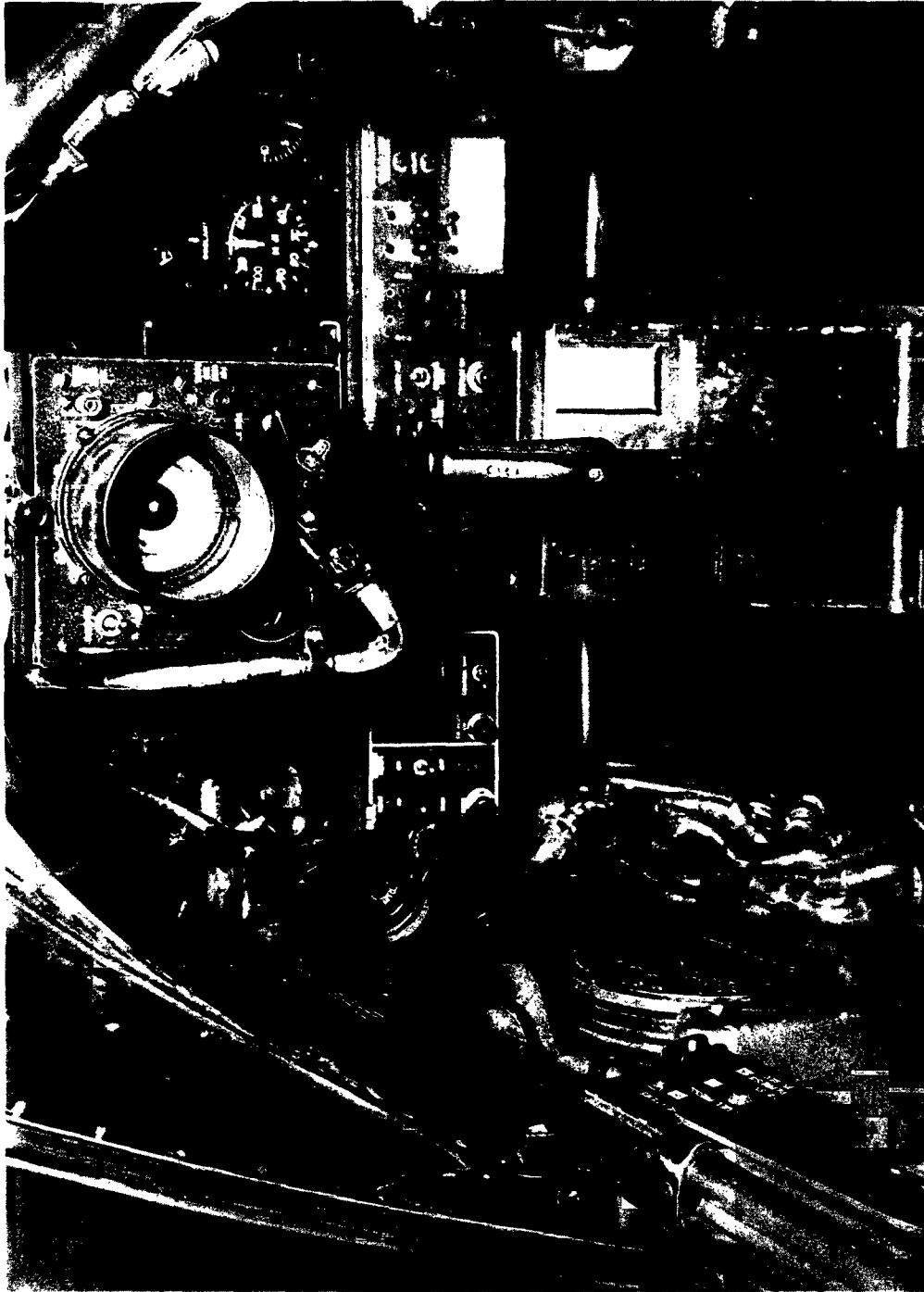

L-82335
Figure 1.- Photograph of indicator unit of radio altimeter as installed
in copilot's cockpit of airplane.



L-80560.1

Figure 2.- Side view of right fuselage of airplane showing location (encircled) of radio-altimeter antennas.

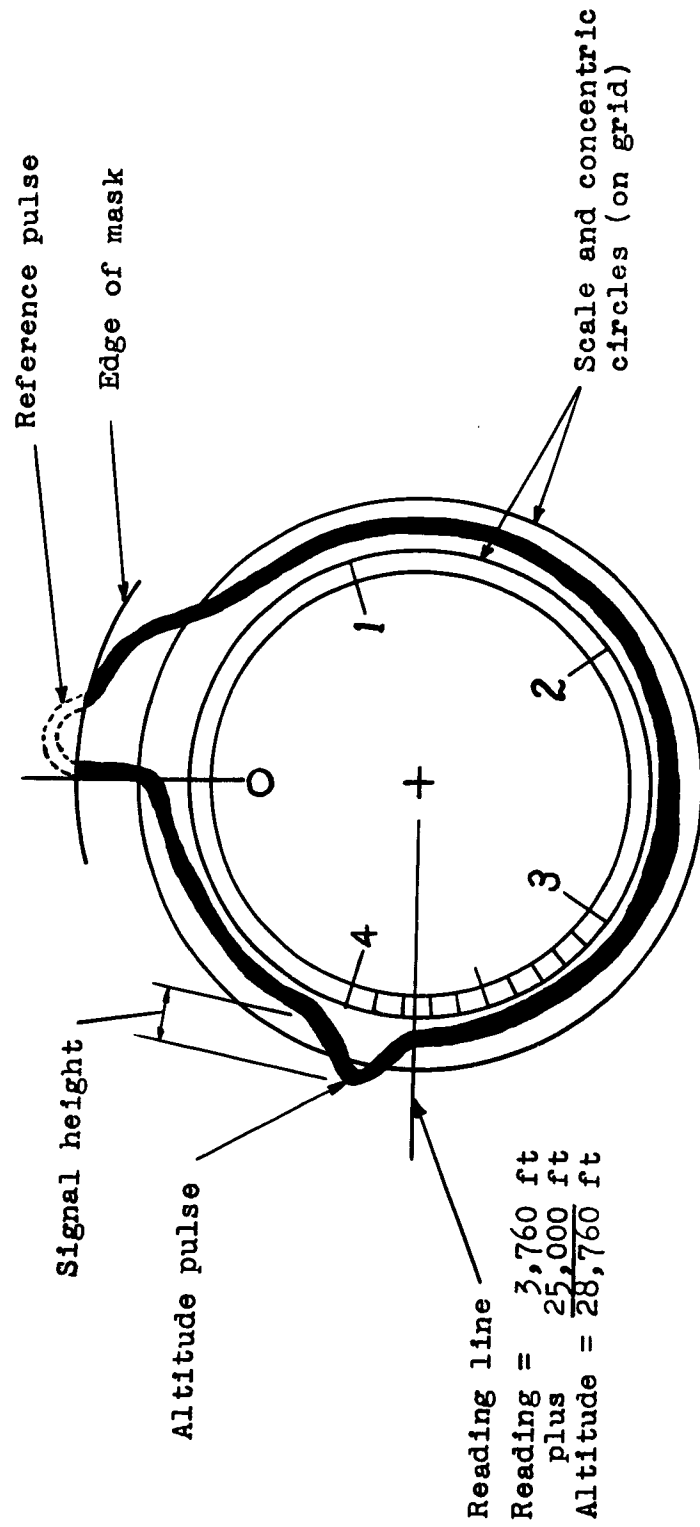

Figure 3.- Tracing of photograph of radio-altimeter indicator showing the method of reading. The grid is shown superimposed on the signal.

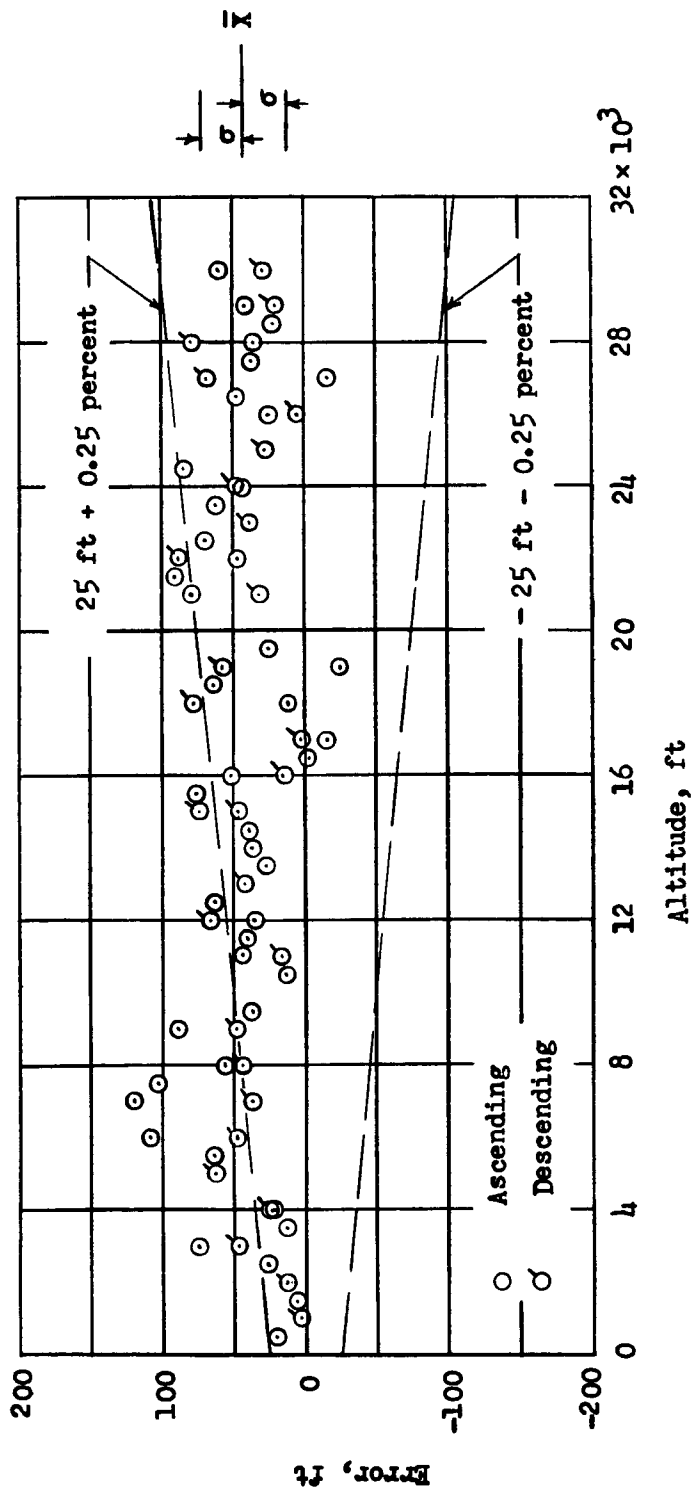

Figure 4.- Variation with altitude of altimeter error (indicated altitude minus geometric altitude from NACA radar phototheodolite unit) compared with accuracy limits for altimeter from reference 5. The arithmetic mean \bar{X} and the standard deviation σ of the data are also shown.

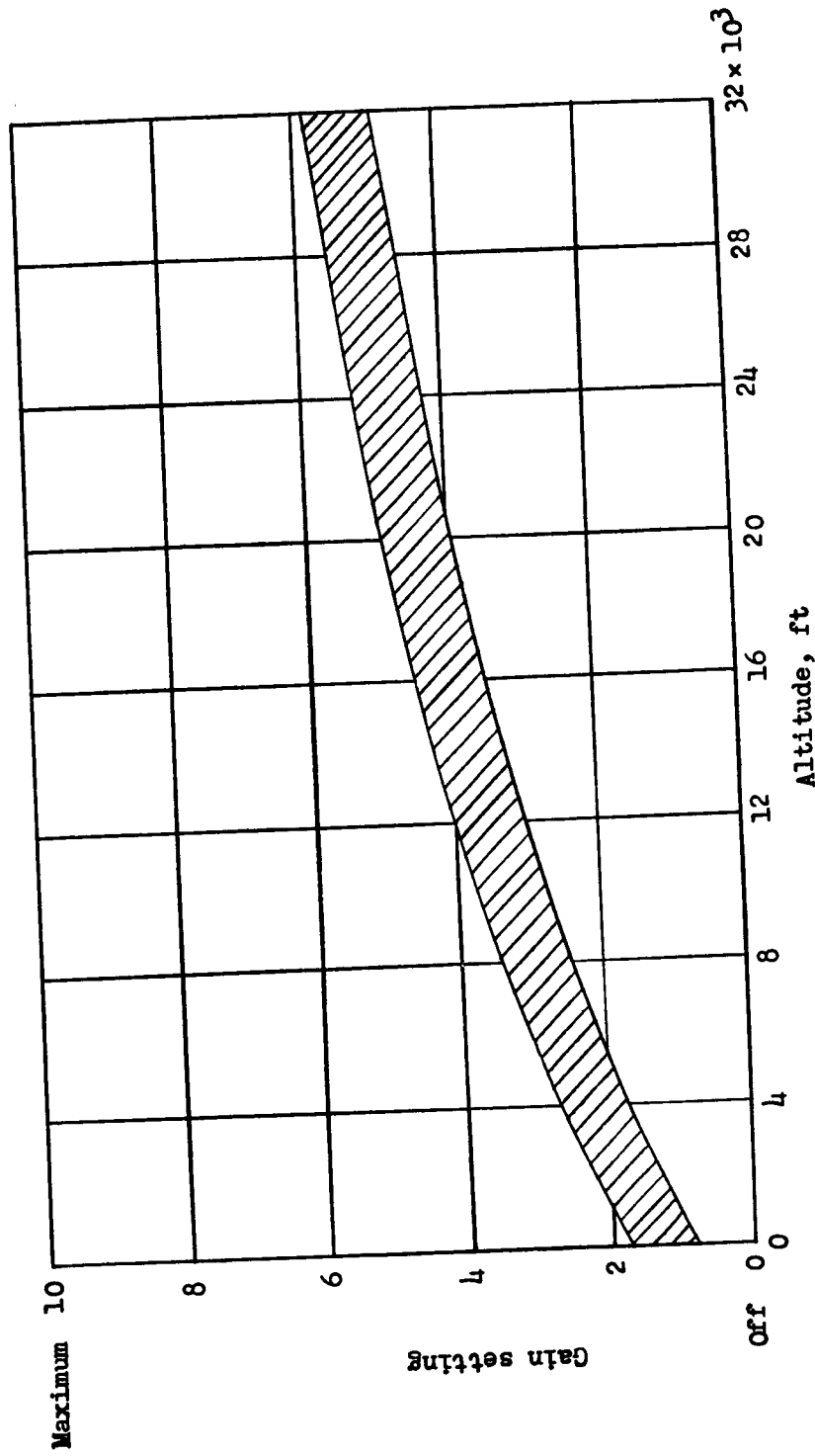

Figure 5.- Variation with altitude of the nominal gain setting (that is, the gain required to produce an altitude pulse about 0.25 inch high) for the radio altimeter.

NACA TN 3186
National Advisory Committee for Aeronautics.
EVALUATION OF THE ACCURACY OF AN AIR-
CRAFT RADIO ALTIMETER FOR USE IN A METHOD
OF AIRSPEED CALIBRATION. Jim Rogers
Thompson and Max C. Kurbjun. May 1954. 15p.
diags., photos., tab. (NACA TN 3186)

A method which may provide a rapid and convenient means for calibrating the airspeed systems of high-performance aircraft is proposed and discussed. The accuracy of the method is comparable with that of the NACA radar phototheodolite method (NACA Rep. 985), but the tests must be performed over a large body of water.

Copies obtainable from NACA, Washington

1. Instruments, Flight (8.1)
2. Research Equipment, Free-Flight (9.1.2)
3. Research Technique - Corrections (9.2.1)
- I. Thompson, Jim Rogers
- II. Kurbjun, Max C.
- III. NACA TN 3186



NACA TN 3186
National Advisory Committee for Aeronautics.
EVALUATION OF THE ACCURACY OF AN AIR-
CRAFT RADIO ALTIMETER FOR USE IN A METHOD
OF AIRSPEED CALIBRATION. Jim Rogers
Thompson and Max C. Kurbjun. May 1954. 15p.
diags., photos., tab. (NACA TN 3186)

A method which may provide a rapid and convenient means for calibrating the airspeed systems of high-performance aircraft is proposed and discussed. The accuracy of the method is comparable with that of the NACA radar phototheodolite method (NACA Rep. 985), but the tests must be performed over a large body of water.

Copies obtainable from NACA, Washington

1. Instruments, Flight (8.1)
2. Research Equipment, Free-Flight (9.1.2)
3. Research Technique - Corrections (9.2.1)
- I. Thompson, Jim Rogers
- II. Kurbjun, Max C.
- III. NACA TN 3186



NACA TN 3186
National Advisory Committee for Aeronautics.
EVALUATION OF THE ACCURACY OF AN AIR-
CRAFT RADIO ALTIMETER FOR USE IN A METHOD
OF AIRSPEED CALIBRATION. Jim Rogers
Thompson and Max C. Kurbjun. May 1954. 15p.
diags., photos., tab. (NACA TN 3186)

A method which may provide a rapid and convenient means for calibrating the airspeed systems of high-performance aircraft is proposed and discussed. The accuracy of the method is comparable with that of the NACA radar phototheodolite method (NACA Rep. 985), but the tests must be performed over a large body of water.

Copies obtainable from NACA, Washington

1. Instruments, Flight (8.1)
2. Research Equipment, Free-Flight (9.1.2)
3. Research Technique - Corrections (9.2.1)
- I. Thompson, Jim Rogers
- II. Kurbjun, Max C.
- III. NACA TN 3186



NACA TN 3186
National Advisory Committee for Aeronautics.
EVALUATION OF THE ACCURACY OF AN AIR-
CRAFT RADIO ALTIMETER FOR USE IN A METHOD
OF AIRSPEED CALIBRATION. Jim Rogers
Thompson and Max C. Kurbjun. May 1954. 15p.
diags., photos., tab. (NACA TN 3186)

A method which may provide a rapid and convenient means for calibrating the airspeed systems of high-performance aircraft is proposed and discussed. The accuracy of the method is comparable with that of the NACA radar phototheodolite method (NACA Rep. 985), but the tests must be performed over a large body of water.

Copies obtainable from NACA, Washington

1. Instruments, Flight (8.1)
2. Research Equipment, Free-Flight (9.1.2)
3. Research Technique - Corrections (9.2.1)
- I. Thompson, Jim Rogers
- II. Kurbjun, Max C.
- III. NACA TN 3186

