

UNCLASSIFIED

AD NUMBER

AD029525

CLASSIFICATION CHANGES

TO: unclassified

FROM: confidential

LIMITATION CHANGES

TO:
Approved for public release, distribution unlimited

FROM:
Distribution authorized to DoD only;
Foreign Government Information; JAN 1954.
Other requests shall be referred to
British Embassy, 3100 Massachusetts
Avenue, NW, Washington, DC 20008.

AUTHORITY

DSTL, DEFE 15/1041, 1 Aug 2008; DSTL, DEFE
15/1041, 1 Aug 2008

THIS PAGE IS UNCLASSIFIED

UNCLASSIFIED

AD NUMBER
AD029525
CLASSIFICATION CHANGES
TO
confidential
FROM
secret
AUTHORITY
RARDE list dated 31 Mar 1966

THIS PAGE IS UNCLASSIFIED

Armed Services Technical Information Agency

AD

29525

NOTICE: WHEN GOVERNMENT OR OTHER DRAWINGS, SPECIFICATIONS OR OTHER DATA ARE USED FOR ANY PURPOSE OTHER THAN IN CONNECTION WITH A DEFINITELY RELATED GOVERNMENT PROCUREMENT OPERATION, THE U. S. GOVERNMENT THEREBY INCURS NO RESPONSIBILITY, NOR ANY OBLIGATION WHATSOEVER; AND THE FACT THAT THE GOVERNMENT MAY HAVE FORMULATED, FURNISHED, OR IN ANY WAY SUPPLIED THE SAID DRAWINGS, SPECIFICATIONS, OR OTHER DATA IS NOT TO BE REGARDED BY IMPLICATION OR OTHERWISE AS IN ANY MANNER LICENSING THE HOLDER OR ANY OTHER PERSON OR CORPORATION, OR CONVEYING ANY RIGHTS OR PERMISSION TO MANUFACTURE OR USE OR SELL ANY PATENTED INVENTION THAT MAY IN ANY WAY BE RELATED THERETO

Reproduced by
DOCUMENT SERVICE CENTER
KNOTT BUILDING, DAYTON, 2, OHIO

SECRET

30/53

SECRET

COPY No. 27

AD No. 29525
copy - copy



MINISTRY OF SUPPLY

ARMAMENT RESEARCH ESTABLISHMENT

REPORT 30/53

WEAPONS RESEARCH DIVISION

Steel Projectiles for the Defeat of Armour at
Large Angles of Attack

Investigations Relating to Headshape and Penetrative Cap

H. F. Hills

A. K. McCracken

NOTICE: THIS DOCUMENT CONTAINS INFORMATION AFFECTING THE NATIONAL DEFENSE OF THE UNITED STATES WITHIN THE MEANING OF THE ESPIONAGE LAWS, TITLE 18, U.S.C., SECTIONS 793 and 794. THE TRANSMISSION OR THE REVELATION OF ITS CONTENTS IN ANY MANNER TO AN UNAUTHORIZED PERSON IS PROHIBITED BY LAW.

This Document was graded
SECRET
at the 61st meeting of the A.R.E.
Security Classification Committee.

**THIS DOCUMENT IS THE PROPERTY OF H.M. GOVERNMENT
AND ATTENTION IS CALLED TO THE PENALTIES ATTACHING
TO ANY INFRINGEMENT OF THE OFFICIAL SECRETS ACTS**

It is intended for the use of the recipient only, and for communication to such officers under him as may require to be acquainted with its contents in the course of their duties. The officers exercising this power of communication are responsible that such information is imparted with due caution and reserve. Any person other than the authorized holder, upon obtaining possession of this document, by finding or otherwise, should forward it together with his name and address in a closed envelope to:-

THE SECRETARY, MINISTRY OF SUPPLY, ADELPHI, LONDON, W.C. 2.

Letter postage need not be prepaid, other postage will be refunded. All persons are hereby warned that the unauthorized retention or destruction of this document is an offence against the Official Secrets Act.

A.R.E.
Publishing Section

Reproduced

FROM LOW CONTRAST COPY.

SECRET

Ministry of Supply

ARMAMENT RESEARCH ESTABLISHMENT

REPORT 30/53

Steel Projectiles for the defeat of Armour at large Angles of Attack.
Investigations relating to Headshape and Penetrative Cap.

H.F. Hills, A.K. McCracken

Summary

Ultra high speed photography has been used for investigating the mechanism of penetration by model 6 pr. A.P.C. steel shot of varying headshape scaled to 20 mm. calibre, and used in 45 degree attack against 18½ mm. homogeneous armour of specification IT80.

Two types of shot failure, dependent on headshape, result from early or late break up of the nose of the shot. With 0.7 c.r.h. and 0.57 c.r.h. the break up of the nose takes place at a later stage than that of the more pointed shape 1.0 c.r.h. Not one of the eight rounds of each type passed through the plate whole. Two shot of 0.57 c.r.h. were recovered whole, one of which had lodged in the plate whilst the other had displaced a large plug and rebounded. When the steel A.P. cap on this design of shot was replaced by one of heavy alloy, penetration whole was recorded at S.Vs. of 2453 and 2799 ft/sec.

The photographs reveal that the rate of turn 25 microseconds after impact is about 200,000 degrees per second, and at 55 microseconds it may be 600,000 degrees or more per second. The commencement of bulging at the back of the plate measured from the time of impact by the shot is recorded as between 17 and 19 microseconds. For plastic deformation to occur in 17 microseconds in a plate 18½ mm. thick the rate must be 3570 ft/sec. The recorded S.V. of the shot was 2452 ft/sec. An attempt has been made to measure the forces acting on the shot over the first 50 or 60 microseconds from the time of impact, before it was thought breakage had taken place.

SECRET

IMPORTANT

This DOCUMENT should be returned to the Chief Information Officer, Armament Research Establishment, Fort Halstead, Sevenoaks, Kent, if retention becomes no longer necessary.

INITIAL DISTRIBUTION

Internal

No. 1	CSAR
2	SSWR
3	SER
4	SWR
5	SMR (Att. Mr. R. Harrison)
6 - 7	SWR (Att. Mr. H. F. Hills, Mr. A.K. McCracken)
8	SWR (WR/AP Section - Major R.V. Thompson, R.A.)
9 - 10	WR Records

United Kingdom

11 - 12	CS/ERDE
13	DWR(D)
14	CEAD
15	CEFWRDE
16	DG of A
17	DNO
18	MO of S
19	Sec. OB

Overseas (through TPA3/TIB)

20 - 37	US - Joint Reading Panel
38	- R and D Board
39 - 45	- Col. Stoddard, U.S. Army Rep.
46	BJSM - P.O. Box 680, Benjamin Franklin Station, Washington, D.C. (Att. Mr. J. W. Gibson)
47	Canada - Dept. Nat. Def.
48 - 51	- Def. Res. Liaison
52	- Nat. Res. Council
53 - 54	TPA3/TIB - Retention

Stock

55 - 70

Contents

Section		<u>Page</u>
1.	Introduction.	1
2.	Object of investigation.	1
3.	Scope of Investigation.	1
4.	Measurements of Model 6 pr. shot.	1
5.	Target size and hardness.	2
6.	Experimental procedure.	2
7.	Information obtained from the photographs.	2
8.	Results.	3
9.	Discussion of results.	4
10.	Conclusions.	19
11.	Recommendations.	20
12.	Bibliography.	20
13.	Photographs.	
Plato No.		
1.	Multiple spark photographs of Round No.281.	
2.	" " " " " " " " 280.	
3.	Photographs of plate and shot damage " 279 & 280.	
3A	" " " " " " " " 284 & 285.	
4.	Multiple spark photographs of Round No.285.	
5.	" " " " " " " " 286 & 287.	
6.	" " " " " " " " 291 & 292.	
7.	" " " " " " " " 288 & 289.	
8.	" " " " " " " " 290.	
9.	Photographs of plate and shot damage " 288 & 289.	
9A	" " " " " " " " 290 & 292.	
10.	Multiple spark photographs of Round No.295.	
11.	" " " " " " " " 293.	
12.	Photographs of plate and shot damage " 293 & 294.	
12A	" " " " " " " " 295 & 297.	
13.	Multiple spark photographs of Round No.325.	
14.	Photographs of plate and shot damage " 322 & 323.	
14A	" " " " " " " " 324 & 325.	
15.	Multiple spark photographs of Round No.295 & 294.	
Appendices		
I.	Outline of Experimental shot.	
II.	Summary of firings in graphical form.	
III.	Diagram showing mode of penetration for 45 degree attack.	
IV.	Space time curve for Bulge Wave Round No.282	
V.	" " " " " " " " 287.	
VI.	" " " " " " " " 295.	
VII.	Turning of shot plotted against time " 281, 293 & 294.	
VIII.	Force diagrams.	
IX.	Graph showing displacement of C.G." " 281.	
X.	" " " " " " " " 293.	
XI.	" " " " " " " " 294.	
XII.	Summary of firing results.	

SECRET

Reference :- P & F 8c 2c
A.R.E. Research Programme 3BLE

1. Introduction

A.R.E. Report No.19/50⁽¹⁾ describes the results of a firing trial which was carried out against machineable armour plate inclined at angles which varied between 30 and 60 degrees from the vertical, and of such thickness that at each angle it was near the perforation limit of the shot. 6 pr. steel capped shot with different headshapes were used, and the authors concluded that given the above conditions an ogive with a pointed tip is inferior to one on which the point is either removed or suppressed.

2. Object of the Investigation

To study more closely the behaviour of these capped shot during penetration, by firing steel 20 mm. calibre scaled models of the 6 pr. A.P.C. shot against machineable armour at 45 degrees from the vertical, and to obtain by the use of high speed photography, ^(a) observations of the subsequent motions and break up of these projectiles and ^(b) their immediate effects upon the target plate.

3. Scope of Investigations

Headshapes of three of the 6 pr. shot were used in the model form and to within reasonable limits the same hardness distribution was obtained. Firings were carried out to obtain the approximate critical velocity for each of the headshapes, and then four of the type of shot which gave the lowest critical velocity were fitted with Heavy Metal Alloy caps, in place of the hardened steel ones, and fired against the same plates.

4. Measurements of the Model 6 pr. A.P.C. Projectiles

Identification	DD	DE	DF
Headshape	1.0 c.r.h.	0.7 c.r.h.	0.57 c.r.h.
Length of shot only	2.13"	2.06"	2.01"
Length of shot plus cap	2.38"	2.36"	2.35"
Distance from base to c.g. capped			
" " " to c.g. uncapped	1.06"	1.00"	0.96"
Moment of inertia about) transverse axis, (uncapped)	227.1 gm-cm ²	244.2 gm-cm ²	246.6 gm-cm ²
Mass of shot capped	5.39 x 10 ⁻⁴ lb-ft ²	5.79 x 10 ⁻⁴ lb-ft ²	5.85 x 10 ⁻⁴ lb-ft ²
" " " uncapped	116.4 gm	121.0 gm	120.5 gm
" " " uncapped	106.0 gm	110.6 gm	110.0 gm

Throughout this report the identification letter will be used when referring to a particular projectile. Appendix I shows in outline, details of the three model 6 pr. shot which have been fired. The external profile of the complete experimental shot with cap is similar for all headshapes, the variation in thickness through the cap depending on the c.r.h. and the radius at the tip. The cavity at the rear of the shot was in each case filled with luting.

5. Target

The target plates were to specification I.T.80, and dimensions were 18"x 4 $\frac{1}{2}$ "x 18 $\frac{1}{2}$ " mm. Faces and backs of the plates were very carefully ground so that the thickness did not vary, and surface scale could not obscure the photographs. Adequate coolant was applied during the grinding operation so that the plate hardness was not materially affected.

Mean hardness for DD attack was 305 B.H.N.
" " " DE and DF " 320 B.H.N.

6. Experimental procedure

The lower end of the target plate was held in restraint by means of a clamp which could rotate through about 90 degrees of angle against great frictional forces after a few milliseconds from impact. Multiple spark photographs were taken of

- a. the projectile during its penetration into the target,
- b. target bulge, perforation or failure of the shot.

In addition to the sequences of high speed photographs, velocities were obtained from three single spark photographs taken before impact so that an accurate assessment could be made of the striking velocity. Time intervals between successive pictures were obtained by recording on a rotating drum camera light from the spark gaps (used as light sources for photography), and from a fork controlled 1000 cycle spark. Measurements obtained from the multiple spark photographs were made from the reprojected image of the negative contained on a screen set up along the line of fire. Adjustment of the negative position was carried out by bringing the reprojected vertical and horizontal grid lines into coincidence with the fixed Rorspex grid, which covers the field of the large lens.

7. Type of Photograph Obtained

From the photographs information was obtained about the following:-

- a. The behaviour of the shot, nature of turning, or breakup where these effects occurred.
- b. The origin, size, and distribution of fragments resulting from impact.
 - . The effects on the plate as regards petalling, plugging, or bending.
- d. Shockwaves in air caused by impact, and the speed of the disturbances to which these waves were due.
- e. The approximate value of the forces involved where curves for displacement against time were plotted.

With regard to (d) it should be mentioned that any intense waves of this nature are recorded on the photographs owing to the Schlieren effect and the long light path from target to camera, and it is of importance to remember that any waves recorded in this comparatively insensitive layout correspond with violent originating disturbances.

8. Results

Examination of the photographs showed:-

- a. In some cases fragments of target plate and shot are not deflected from the front of the plate, and the bulge in the back surface remains roughly symmetrical about the point of impact, with no appreciable lengthening.
- b. In other cases a lip was formed on the front surface of the target plate which deflected the fragments, and the bulge increased in length.
- c. A few microseconds after impact the cap broke and the shot turned about its transverse axis so that its base moved away from the normal to the plate.
- d. Faint air waves at small regular intervals which lie approximately parallel to the front and back surface of the plate.
- e. Bulging of the rear surface of the plate took place at an early stage of the penetration process.
- f. A few microseconds after impact a heavy curved shockwave appeared behind the target plate in most of the pictures and is associated with the bulge.
- g. Most of the plugs which were produced hinged upwards, but in three cases cleavage of the metal in what would normally have been a plug took place, and the metal hinged in two pieces.

8.1 Shot DD all broke, and in eight rounds out of nine bulging at the back of the plate was roughly symmetrical about a normal. The bulge produced by the other round (260) was much longer and a hinged plug was finally detached.

Photographs show that metallic fragments were deflected from the front surface of the plate by a lip formed on this surface by round 280, and rounds 283 and 285 showed very slight lipping. No signs of this effect were visible in pictures of other rounds of the DD series. Three rounds gave perforation.

8.2 Shot type DE all broke, and bulging at the back of each plate was more drawn out. Photographs show quite clearly the fragments being deflected from the front surface of the plate.

Four rounds out of seven in this series perforated the plate.

8.3 Shot type DF remained whole in two rounds out of eight. One remained lodged under a hinged plug and the other one after coming to rest in the plate bounced out again. Seven of the rounds perforated the target and round number 300 with a velocity of only 2250 ft. per second gave a scoop.

Deflection of the particles occurred at each round, and bulging was again more drawn out than in the DD firings.

8.4 Shot type DF fitted with heavy alloy caps in place of the hardened steel caps remained whole. Four rounds were fired through a velocity range of 2386 to 2799 ft. per second. Deflection of the particles took place at each round and lengthening of the bulge was again considerably greater than for the DD firings.

8.5 DD target plates were damaged on their front surfaces for lengths varying between 3.6 and 4.6 cms. except in the case of round 280 where the damage extended to 5.6 cms.

DE damage varied between 5.1 and 5.8 cms. in length.

DF damage can be split into two groups

5.1 - 5.6 cms.

4.1 - 4.6 cms.

DF fitted with heavy alloy caps varied between 4.5 and 5.5 cms.

9. Discussion of Results

The high speed photographs show that when these A.P.C. shot attack home hard armour plate at an angle of 45 degrees, the hard steel caps penetrate for only a very small distance into the plate before they break up or shatter. The asymmetrical forces acting on the cap at the time of impact must be primarily responsible for this very early break up, and as the shot continues forward it squeezes the fragments out from the front of the target. Broadly speaking, we can say that in oblique attack the steel shot (A.P. or A.P.C.), if it remains whole and penetration of the target is effected, will pass through four well defined stages.

- a. Impact and breaking of the cap if one is fitted.
- b. Turning away from the normal to the plate due to the unbalanced forces acting on the nose.
- c. Turning towards the normal when the back of the plate fails.
- d. Penetration.

The ogival shape of head of 1.4 or 1.0 c.r.h. like DD tend to ricochet off the surface of a target at angles of 45 degrees and upwards. In sliding over the surface it scoops out metal on the incident side whilst forming a bulge on the reverse side (unless the target is too thick for bulging to occur). The semi-angle of the nose is about 55 degrees and so the initial dig in by the nose is hardly sufficient to prevent its skidding down the plate. This pointed shape was standard service design during World War II, but in general it was only expected to attack at angles up to 30 degrees, and for this purpose it was very efficient.

It is now known that perforation of a plate is usually achieved by one of the following mechanisms or by a combination of the two:-

- (i) the forwards and sideways displacement mechanism.
- (ii) punching or shearing mechanism.

Sharp nosed projectiles such as type DD are more effective at angles of attack up to 30 degrees where t/d (Plate thickness/diameter of shot) is greater than 1, and the plate is sufficiently ductile to allow the material to be pushed aside to form front and rear petals. At 45 degrees attack there is greater difficulty in pushing aside plate material on that side of the head remote from the normal, due to the larger contact area with the plate, and this is associated with a greater turning moment on the shot and greater unbalanced compressive force. Perforation is thus more likely to be accompanied by plugging than by petalling.

Blunt nosed projectiles are more effective in attack at 45 degrees against homo hard plate when t/d is roughly 1 or below, as this shape is more efficient for punching and shearing. It was found (2) that against $\frac{3}{8}$ " armour (B.H.N. 240 approx.) at 60 degree attack, a flat headed shot (i.e. right circular cylinder) would perforate with a lower critical velocity than either of the other headshapes which were fired, their order of merit being as under.

<u>Calibre</u>	<u>Headshape</u>	<u>Critical Vel. ft/sec</u>
20 mm.	Flat head	1500
"	0.5 c.r.h.	1941
"	scaled down 5.25" A.P. shell	2076
"	" " 15" " "	2230
"	1.4 c.r.h.	2537

9.1 Appendix III illustrates the normal mode of penetration for 45 degree attack against I T.80 plate with a t/d ratio of about 1, near the critical velocity.

The diagrams show

- (a) Nose penetration deep enough to overcome the tendency to ricochet off the surface of the plate. Bulging of the back surface is well established and the shot has not turned away from the line of fire.
- (b) Forward velocity combined with the rapid turning of the shot about its transverse axis has resulted in further penetration but in a downwards direction. A lip which has been formed gives some radial support to the lower side of the nose and this prevents any further tendency of the shot to leave the plate when the base strikes. Bulging has increased both in length and depth.
- (c) Rapid yielding of the metal at the lower end of the bulge has reversed the couple acting on the nose, and the base has turned in a direction towards the normal of the plate. In turning, the body of the shot has levered the lip downwards.
- (d) Further yielding of the metal in the bulge has caused the lower end to shear first and thus form a hinged plug. The sudden release of pressure on the upper part of the nose has caused the base to swing round with a greater acceleration. The lip has become detached from the plate and the body has struck the edge of the hole with such intensity that breakage of the shot usually occurs.

- (e) The projectile is now in position for final penetration, with plug detached and lip falling clear.

Round 280, which broke in its later stages of penetration, had an ogival headshape but the photographs show that it behaved in a very similar manner to the hemispherical nosed shot (Plate 2).

In 30 degree attack by blunt nosed projectiles with a t/d ratio of about 1, punching is more straight forward because the tendency to ricochet is less, and therefore the armour absorbs a greater proportion of the shot energy.

9.2 All the indications show that the DD type of shot break at the nose (with the exception of round No.280) at a very early stage after impact. Multiple spark photographs showing an attack against $18\frac{1}{2}$ mm., I.T.80 armour at 45 degrees by a type DD shot can be seen in Plate 1.

This round No.281 only succeeded in making a deep impression on the face of the plate and a bulge at the back. Tiny pieces of the shot nose became embedded in the impression, and this condition was typical of the other DD failures with the above exception.

Plate 1

<u>Round No.281</u>	<u>2400 ft/sec</u>	<u>Non-perforation</u>	<u>DD</u>
<u>Frame No.10</u>	<u>Picture No.1</u>	<u>t = 0 microseconds</u>	

Shot with slight initial yaw just making contact with the target plate. (A white loop which appears at the back of the plate in each photograph is caused by a mark on a sheet of Perspex which protects the field lens, and should be disregarded).

<u>Frame No.11</u>	<u>Picture No.2</u>	<u>t = 26 microseconds</u>
--------------------	---------------------	----------------------------

The cap is probably broken at this stage. A very slight bulge can be seen on the back surface of the plate. The nose of the shot is beginning to rotate downwards about its transverse axis due to the force being exerted on the forward end of the shot. Break-up of the cap on the incident side of the plate leads to the reflection on this side of fast moving fragments which are distributed uniformly about the region of impact.

<u>Frame No.12</u>	<u>Picture No.3</u>	<u>t = 34 microseconds</u>
--------------------	---------------------	----------------------------

Bulging has increased in depth and the base of the shot has turned still more towards the plate.

<u>Frame No.13</u>	<u>Picture No.4</u>	<u>t = 49 microseconds</u>
--------------------	---------------------	----------------------------

Further turning of the shot obstructs the movement of debris in an upwards direction and the bulge has increased slightly in depth. As there is still no deflection of the fragments away from the face of the plate, the nose must be breaking. (With shot remaining whole it would have increased the length of the bulge by penetrating down the plate, while a lip of metal would have been raised which in turn would have impeded the flow of fragments down the plate).

Frame No.14

Picture No.5

t = 80 microseconds

With further disintegration of the nose, the base of the shot has moved forward and has become lost in the debris. The bulge has not become significantly deeper and is still approximately symmetrical. Many more fragments are visible. The curved line immediately above the bulge is caused by particles from a chalk mark on the back of the plate being set in violent motion. A wave can be seen above the bulge and although present in the two earlier pictures was too faint for good reproduction.

Other faint waves which do not appear in these reproduced pictures are of interest. At the instant of impact a compression wave is started in the steel target and on its arrival at the rear surface it is reflected as a tension wave. These alternations between the front and rear surfaces take place every 3.7 microseconds in a plate 18½ mm. thick, and they continue for several microseconds before finally being damped out. At each reflection, an air wave is sent out, and these waves can be seen on some of the original photographs looking like a series of equally spaced parallel lines at the rear of the plate.

The first wave is propagated in the air 3.7 microseconds after impact and this is followed by others at regular intervals of 7.4 microseconds. Some of these intervals have been measured and further confirmation was obtained by measuring the time intervals between waves sent out from a 44 mm. plate. The pressure amplitude is small in air and the wave velocity is only a little above the velocity of sound in air. In steel the amplitude will of course be very considerable and may well be a strong contributory cause of early cap or nose shatter.

Frame No.25

Picture No.6

t = 921 microseconds

The plate is now beginning to move against the friction of the clamp, and larger pieces of shot can be seen moving downwards and away from the front surface. The bulge is still roughly symmetrical in shape and has not appreciably increased in size. There is slight permanent bending of the plate.

In contrast to this sequence of pictures showing early breakup of the nose of type DD shot, the next one shows the effects of later breakup of round No.280 which, although a DD shot, behaved so differently to the rest. See Plate 2.

(The markings in the background were caused by a previous round which damaged some protective sheets of Perspex in front of the field lens).

PLATE 2

Round No.280

2534 ft/sec

Perforation

Shot type DD

Frame No.10

Picture No.1

t = 0 microseconds

Shot with slight initial upwards yaw is just making contact with the target plate.

Frame No.11

Picture No.2

t = 34 microseconds

The cap is probably broken and the fragments are being deflected slightly away from the plate and downwards. Only a small amount of material is going upwards. Bulging of the plate is well advanced and the base of the shot is being rotated towards the plate and away from the normal.

Frame No.12

Picture No.3

t = 42 microseconds

Bulging has progressed and further turning of the shot can be seen. A lip is forming on the front surface of the plate which is already preventing fragments from moving down the plate.

Frame No.13

Picture No.4

t = 60 microseconds

The shape of the bulge now ceases to be symmetrical about the point of impact. It is lengthening and becoming deeper. The shot has turned still further and the base is almost touching the plate. Deflection of the particles away from the plate continues and it can be seen how the lip has been levered round by the body of the shot as it proceeds into the target.

Frame No.14

Picture No.5

t = 91 microseconds

Further yielding of the metal in the bulge relieves the force which has been acting on the top of the nose, and another force acting on the under side of the nose is turning the body of the shot towards the normal of the plate. This accounts for the continued hinging round of the lip which can be seen, and also the change in the fragment pattern along and above the line of fire.

Frame No.18

Picture No.6

t = 131 microseconds

Shearing of the metal in the bulge is now complete and a plug is being hinged back. This sudden release of pressure on the top of the nose must now further accelerate the turning of the shot towards the normal if penetration is to succeed. Fragments of metal can be seen escaping from below the hinged plug.

Frame No.22

Picture No.7

t = 176 microseconds

Further turning of the shot has broken the lip. The shot has also broken up and pieces of the nose can be seen escaping under the plug. Pieces of the body can also be seen emerging from the front of the plate.

Frame No.25

Picture No.8

t = 909 microseconds

Perforation is complete. The plug which is now detached from the plate can be seen near the top left hand side of the picture, while pieces of broken shot may be seen emerging roughly at normal to the back of the plate. Larger pieces of shot can be seen in front of the plate.

The recovered plug provides further evidence that this shot remained whole up to the time that the couple on the nose was reversed. A clean smooth outline of the nose from the shoulder to the tip has been impressed in the metal. Had the nose broken at an early stage the plug would have been deeply scored by the fragments.

Plates 3 and 3A

The upper rows of photographs show front and rear damage to the target plate for rounds 279, 280, 284 and 285, and the lower ones marked A, B, and C show the three plugs produced. The plug from round 279 is marked A and shows extensive scoring by the broken nose. C shows equally bad scoring whereas B (round 280) shows a smooth indent of the nose from shoulder to tip. Round 284 did not produce perforation but scoring can be clearly seen inside the scoop. The next series of pictures also illustrate the mechanism of perforation when early breakup of the nose occurs.

Plate 4

<u>Round No. 285</u>	<u>2769 ft/sec</u>	<u>Perforation by DD</u>
<u>Frame No. 3</u>	<u>Picture No. 1</u>	<u>t = 0 microseconds</u>

Shot with no initial yaw is about to make contact with the target.

<u>Frame No. 4</u>	<u>Picture No. 2</u>	<u>t = 13 microseconds</u>
--------------------	----------------------	----------------------------

Impact has taken place. Cap is being broken.

<u>Frame No. 5</u>	<u>Picture No. 3</u>	<u>t = 29 microseconds</u>
--------------------	----------------------	----------------------------

Turning of the shot is almost imperceptible. Bulging is just commencing. Debris is undeflected and there is approximately the same amount of material moving up or down the plate.

<u>Frame No. 6</u>	<u>Picture No. 4</u>	<u>t = 54 microseconds</u>
--------------------	----------------------	----------------------------

Base of the shot is now obscured by fragments which are being reflected by the target face. The bulge and fragments are roughly symmetrical about a normal to the plate which is characteristic of early nose breakup.

Turning of the shot in the early stages by such a small amount would be accounted for if the nose broke before a turning moment could be fully applied.

<u>Frame No. 11</u>	<u>Picture No. 5</u>	<u>t = 116 microseconds</u>
---------------------	----------------------	-----------------------------

No lip has formed to deflect the fragments. The shot follows the nose fragments behind the rapidly shearing metal in the bulge. (Particles of chalk are again present about the bulge).

<u>Frame No. 23</u>	<u>Picture No. 6</u>	<u>t = 266 microseconds</u>
---------------------	----------------------	-----------------------------

Perforation is complete and the target is bending. Larger pieces of shot can now be seen moving away from the front of the plate. The deepest part of the bulge has failed and two hinged pieces have become detached from the plate.

<u>Frame No. 24</u>	<u>Picture No. 7</u>	<u>t = 440 microseconds</u>
---------------------	----------------------	-----------------------------

The two separated pieces can now be more clearly seen. The plate is beginning to move away from the gun.

This is the last picture in the series taken after a longer interval of time than the others. Movement of the plate has continued.

9.3 The four DE type rounds which perforated the plate were 286, 287, 291 and 292 and out of the sequence of 25 pictures which were taken of each round, four selections have been made to illustrate the close similarity between them at each stage of perforation (Plates 5 and 6). It will be seen that all the plugs hinge upwards, and although the shot is broken in every case when it emerges from the hole, the area of nose which has been in immediate contact with the plug suffers less damage than the underside of the nose.

The plugs produced by these four rounds have smooth imprints of the shot nose, indicating that the part which was in contact with the yielding metal of the plate must have broken at a late stage of penetration. Deflections of the particles by lip formation on the front of the target plate, together with the rapid lengthening of the bulge gives added proof. The shot, by remaining whole throughout the period when it turned away from normal to strike the plate near its driving band, would survive very severe bending stresses due to the forces acting on the nose and from impact of the base on the plate. Later, as it pushed deeper down into the plate, more radial support would be obtained to furnish some temporary relief to the nose. When the bulge metal fails the turning moment is reversed and support to the nose is transferred from the top (the area which was in contact with the bulge) to the underside of the nose. In this position a violent reversal of the rotation of the shot or further considerable damage of the plate would be necessary to allow the forward motion of the shot to continue. The forces thus brought into play may break the nose of the shot already highly stressed by tension. The body which may also be broken, usually rebounds from the front of the plate, if it does not continue through the hole.

Plates 7 and 8 illustrate the similarities of the remaining three rounds of the DE shot which produced scoops in the plate only (288, 289, 290). Turning of the shot from normal, lipping, and lengthening of the bulge, are all characteristics of a shot which does not break up in its early stage of perforation. Pieces of shot nose, when they were recovered, were fairly large in size and therefore damage must have been less severe than that sustained by the DD shot.

Target damage, plugs, and recovered pieces of DE shot are shown on Plates 9 and 9A.

9.4 DF type shot (headshape almost hemispherical) perforated the plate with a slightly lower critical velocity than types DD and DE although it is interesting to note that so far in this trial no shot has passed through the plate and remained whole. Two DF rounds although they did not pass through the plate, gave perforation and remained whole. They were Round No. 294, which displaced a fairly large plug and then bounced back from the front of the plate, and Round No. 296, which lodged under a hinged plug. Their velocities were 2394 and 2418 ft/sec respectively. Increasing the velocity, the next four rounds broke at 2441, 2445, 2452 and 2576 ft/sec. Photographs indicate that these shot remain whole during the early penetration process although three of the rounds (295, 297, 299) differ from the others in the series by finally shearing the metal

in the bulge at about the mid position of what would normally be a plug, and forcing one piece to hinge upwards and the other piece downwards. This effect is possible when the nose of the shot splits axially, and one of the broken pieces moves forward slightly in advance of the others, due to its being squeezed out of position. Lengthening of the bulge is likely to be more restricted, and in place of deep shearing which happens in the case of plugging, excessive local stretching will occur and this will continue until cleavage takes place, when the broken shot, in order to continue in a forward direction, must force open the separated surfaces and emerge through the opening provided.

The above three rounds succeeded in perforating the plate by a combination of first punching, and later when broken, pushing aside the material in the way that the pointed shot behaved (Plate 4).

The length of damage to the front surface of the plate was similar in the two cases - 3.6 cms. - 4.6 cms. for DD and 4.1 - 4.6 for DF. More damage was sustained by the plate for round 285 because of the higher velocity.

Plate 10 illustrates round 295 and is typical of the other two rounds (297, 299).

Plate 11 shows the normal process of plate perforation with this type of shot.

Plates 12 & 12A show DF plate damage and pieces of recovered shot.

Appendix II summarises the firings in graphical form. The results are very similar to those shown in A.R.E. Report 19/50 and when the scale and hardness factors are allowed for, agreement is within 200 ft/sec.

9.5 The four DF rounds which were fitted with heavy alloy caps in place of the hardened steel ones, were fired at velocities ranging from 2386 to 2799 ft/sec. and they were all recovered whole.

Two penetrated the plate and two perforated by plugging (322 and 323 penetrated).

Plate 13 shows 325 which perforated the plate.

<u>Round No. 325</u>	<u>2386 ft/sec</u>	<u>Perforation Shot type DF</u> (H.A.C.)
<u>Frame No. 7</u>	<u>Picture No. 1</u>	<u>t = 0 microseconds</u>

The shot is turning about its transverse axis, cap fragments are being slightly deflected, and a well defined bulge wave can be seen developing.

(Damage to the plate caused by two earlier trials explains the irregular outline above and below the position where the present attack is taking place).

<u>Frame No. 8</u>	<u>Picture No. 2</u>	<u>t = 28 microseconds</u>
--------------------	----------------------	----------------------------

Further turning of the shot is accompanied by lengthening and deepening of the bulge. Cap fragments are being deflected a little more.

Frame No.9

Picture No.3

t = 59 microseconds

Lipping is more pronounced and yielding of the metal in the bulge is rapidly taking place.

Frame No.10

Picture No.4

t = 104 microseconds

Shearing at the lower end of the bulge can now be observed. The outline of the plug and the position at which hinging will occur, can be seen. Further enlargement of the lip and its continued hinging in a clockwise direction indicates that the shot body must be levering it round as the nose follows the upward hinging of the plug.

Frame No.11

Picture No.5

t = 160 microseconds

The front edge of the plug is now almost clear of the plate and fine metallic particles can be seen emerging. Hinging of the lip is still proceeding.

Frame No.15

Picture No.6

t = 243 microseconds

The metal on which the plug was hinging has fractured, and the plug is now free to move out from the plate. The fracture can be seen as a very faint crack. Continued hinging has broken the lip away from the plate, and the particles are now falling in towards the plate.

Frame No.23

Picture No.7

t = 386 microseconds

With the plug now clear of the plate the round nose of the shot can be seen at its maximum penetration. A large piece of the lip can be seen near the bottom of the picture where it has fallen away from the plate.

Frame No.17

Picture No.8

t = 523 microseconds

Further separation between the plug and the plate shows only very fine particles escaping from the hole, and as the shot nose is no longer visible it must now be moving out of the plate in the reverse direction, by elastic forces. As no large pieces of cap material have emerged from the hole this is a further proof that the cap breaks up in the very early stage of perforation and is squeezed out from the front of the plate. Without further firings there is not sufficient evidence to show how this heavy alloy cap so completely protects the shot from breakage.

It will be seen in general that the mechanism of penetration has not been altered. There is the turning of the shot away from normal, penetration down the plate, long drawn out bulge deepening at the end, hinging of the plug, and lipping on the front of the plate.

With the exception of Round 323, the length of frontal damage to the plate was consistent with the DE and DF rounds which remained whole for a long time and did not break axially. In the case of Round 323 the plate was considerably overmatched with a velocity of 2799 ft/sec. Target damage, plugs and shot are shown on Plates 14 and 14A.

9.6 Time at which bulging is first observed

Examination of Frame 7, round No.295 (Plate 15) shows impact about to take place. With a striking velocity of 2452 feet per second, impact occurred 1 microsecond later than the time recorded

for this photograph. In Frame 9 of this sequence, commencement of the bulge can just be observed and as the recorded time interval between the two frames is 18 microseconds, the actual time between impact and the first appearance of the bulge must be 17 microseconds.

Similarly it can be shown by Frames 10 and 12 of round No. 294 (Plate 15) that the time interval between impact and the first appearance of the bulge must be 19 microseconds.

These two examples have been chosen to illustrate the very rapid rate at which the plate material is deformed, because it does not happen very frequently that two photographs in a sequence show in one case the shot just making, or about to make, contact with the plate and another one showing the very first indication of bulging. While it is simple to compute the time of arrival of the shot at the plate from its striking velocity, the time at which bulging first becomes visible cannot be accurately determined. Table 1 will therefore only record approximate time intervals for these other rounds, with the exception of round 282 where early bulging can be seen.

Table 1

Round No.	Frame Nos.	Time interval in microseconds	Remarks
278	22 to 23	22	
279	15 " 21	19	
281	10 " 11	26	
282	7 " 9	17	
284	6 " 8	22	Bulging well advanced
288	4 " 6	24	
292	2 " 4	27	" "
293	4 " 5	24	Before impact on No. 4

If we take the case quoted in the first example (295) then plastic deformation must have taken place at a rate of 3570 ft/sec although the striking velocity of the shot was only 2452 ft/sec and for round 294 it must have been at the rate of 3194 ft/sec for a striking velocity of 2394 ft/sec.

9.7 Bulge Wave

In an earlier part of this report reference was made to a wave which appears in the photographs and which is undoubtedly associated with the bulge in the plate.

It is considered that the bulge acting like a piston moves forward with high acceleration in the very early part of its travel, but quickly attains a uniform velocity lasting for 200 or more microseconds. The wave set up by this single impulse is easily distinguishable from the waves sent out by the elastic reflections from the plate as it is curved in shape whereas the latter appear as a number of equally spaced lines running approximately parallel to the faces of the plate. The bulge wave has a greater amplitude and in some cases can be seen travelling across the full diameter of the field lens.

The smallest observed time interval between impact and the first appearance of the wave is 29 microseconds and in this time four reflected waves will have emerged from the back of the plate, but as their velocity is less than that of the bulge wave they are soon left behind and further decay in amplitude leads to fade out.

Appendices IV, V and VI illustrate graphically

- a. Time at which shot reached the plate (282, 287, 295)
- b. Space time curve of the bulge wave (" " ")
- c. Space time curve of the bulge growth (- 287, 295)

The straight line representing bulge increase would suggest that this increase takes place with a uniform velocity, but the pictures show that the wave is not seen close in to the plate when it first appears, and this suggests that in its very early stage the bulge metal is being very rapidly accelerated, and until a uniform velocity is reached the wave cannot begin to form.

Plastic deformation in the plate must commence within the first few microseconds of impact since the shot with a velocity of 2400 ft/sec would take 25 microseconds to traverse a distance of 1.85 cms (plate thickness) whereas bulging is observed 17 microseconds after impact.

9.8 Turning of the shot about its transverse axis

A few microseconds after impact the base of the shot moves about its transverse axis, away from the normal to the plate, while the nose is of course being deflected downwards by the unbalanced forces acting upon it.

The photographs have revealed that the rate of turn 25 microseconds after impact is about 200,000 degrees per second and at 55 microseconds it may be 600,000 degrees per second or more. All these types of shot have very similar rates of turn but the DD type do not turn as far away from the normal (except for Round 280, the one which broke so much later than the others in this series) which would be expected if the nose broke early. The turning moment would be removed when breakage occurred, until the solid part of the body or nose again made contact with the plate, and then due to its changed headshape the force distribution would be altered. A jagged fracture at the forward end of the projectile would lead to further breakage and the turning moment might never become firmly established in that direction again.

9.9 Forces acting on a shot

An attempt has been made to measure the retardation of the centre of gravity, and the angular acceleration about the centre of gravity of a shot during oblique attack of armour plate. Appendix VII shows the angle of turning of the shot about its transverse axis, plotted against time. Appendices IX, X, XI are space time curves showing the displacement of the c.g. (Retardation of the c.g.) The values obtained are necessarily very approximate owing to the very small distances and times involved, but they give some measure of the forces experienced

by the shot during its attack. The forces are represented in Appendix VIII^(a) where F_H and F_V are the horizontal and vertical resolutes of the resultant force F . Measurements, against time, were taken of the moment along the line of fire of the centre of gravity of the shot, and of the angular rotation of the shot about its centre of gravity. It was not possible to measure the vertical displacement of the centre of gravity caused by F_V because the distances involved over the same period of time were even smaller than in the case of F_H . Also, F_V cannot be determined indirectly for although the resultant moment of F_H and F_V about the centre of gravity can be found from the angular acceleration of the shot, the forces themselves cannot be found without knowing the point of application of their resultant F .

It is possible to set a lower limit for the force F_V during the very early stages of penetration by the fact that at this stage its moment is in the opposite sense to that of F_H . This condition may not obtain after a very few microseconds when the shot could be in an advanced state of ricochet, both forces having a moment in the same sense about the centre of gravity.

This is unlikely to happen at 45 degrees and fairly high velocities, if the shot remains whole, although it did happen in some cases to the DD shot which made shallow impressions and whose nose broke early during the attack. Moreover, although at the precise instant of impact at 45 degrees $F_V = F_H$, whatever the headshape of the shot a precise value cannot be stated of F_H at this instant, but only a constant mean value over the interval of observation.

A knowledge of the constants of a shot together with its velocity at any time, gives values of the shot's rotational and translational energy and therefore of the rate of working of the shot against the plate over this interval.

Let $2c$ = acceleration of the centre of gravity along the line of fire ($c < 0$)

$2\dot{\nu}$ = angular acceleration of the shot ($\dot{\nu} > 0$)

m = mass of shot

I = moment of inertia of the shot about its transverse axis

V_s = striking velocity of shot

Then $F_H = 2mc$

Mean rate of working over interval $t = 2mc(V_s + ct)$

Moment of F_H and F_V about the centre of gravity = $2I\dot{\nu}$

Mean rotational rate of working over an interval $t = 2\dot{\nu}^2 t I$

Translational energy at time $t = \frac{m}{2}(V_s + 2ct)^2$

Rotational energy at time $t = 2I\dot{\nu}^2 t^2$

Total energy at time $t = \frac{m}{2}(V_s + 2ct)^2$

Total mean rate of working over interval $t = 2mc(V_s + ct) + 2\dot{\nu}^2 t I$

Figures are given for the above quantities except for the total energy and the total rate of working, these being almost the same as the translational energy and the translational rate of working over the interval considered (60 microseconds).

The acceleration $2c$ was obtained as follows.

The law of motion of the centre of gravity of the shot was taken to be $S = a + bt + ct^2$.

Equations obtained from the observations were solved for c by the method of least squares.

The form of observation equation implies an assumption of constant retardation, whereas it is almost certainly a function of distance (time), but the nature of the observations does not justify the introduction of a term in t^3 into the equation.

The value of the striking velocity obtained in the normal manner was not used in the equation in place of b , owing to the danger of small zero errors greatly affecting the value of c obtained. The interval of the measurements is about 60 microseconds, and the mean rate of working is quoted for this time.

Similarly, from the measurements of time and angle, the angular acceleration was obtained from observation equations of the type:-

$$\theta = a + \beta t + \gamma t^2$$

In this case there is a maximum of θ for some value of $t > 60$ microseconds, for the shot reverses its rotation until its deflection is about normal to the plate in the case of penetration. As the inflexion in the curve does not occur early within the period of our observations, a quadratic can be fitted with reasonable accuracy for the first fifty or sixty microseconds.

The turning moments measured are of the order of 2 tons-wt.-ft. and the forces F_H are of the order of 50 tons-wt. These values will not be reached immediately on impact but will be approached rapidly, and exceeded as the contact area of the plate and shot increases. The rotational energy of the shot is seen to be very small generally compared with its translational energy. The figure quoted for the rotational energy at 60 microseconds will certainly be too large, owing to the lack of a term in t^3 in the observation equation. It is probably true to say that at thicknesses of about 1 calibre or more, where a condition of ricochet followed by a condition of topple is the normal pattern of penetration at angle, the energy of rotation at no stage exceeds 10% of the energy of translation of the shot in the essential stage of the penetration. When plugging occurs the shot may swing back with a high proportion of the total energy, but by this time the essential part of the penetration has taken place. Therefore, although the turning of shot is a disadvantage in angle attack, it is not for the reason usually stated, particularly at high angles of attack. The division of energy between the degrees of freedom due to shot rotation is of less importance than the loss of direction of the nose of the shot. For shot of length about 5 cms. it is reasonable to suppose that the centre of pressure on the nose has a lever of about $1/15$ ft. about the centre of gravity during the early stages of penetration giving us $F_H \geq 30$ tons-wt. very approximately. The rate of working of the shot against the plate along the line of fire is about 2×10^8 ft.-lbs. per second, and if our estimate of F_H is reasonable the rate of working against this force is between 1×10^8 and 2×10^8 ft.-lbs. per second.

Ignoring the small energy of rotation it is seen that the initial power of the shot is of the order of three-quarters of a million horse-power.

by the shot during its attack. The forces are represented in Appendix VIII^(a) where F_H and F_V are the horizontal and vertical resolute of the resultant force F . Measurements, against time, were taken of the moment along the line of fire of the centre of gravity of the shot, and of the angular rotation of the shot about its centre of gravity. It was not possible to measure the vertical displacement of the centre of gravity caused by F_V because the distances involved over the same period of time were even smaller than in the case of F_H . Also, F_V cannot be determined indirectly for although the resultant moment of F_H and F_V about the centre of gravity can be found from the angular acceleration of the shot, the forces themselves cannot be found without knowing the point of application of their resultant F .

It is possible to set a lower limit for the force F_V during the very early stages of penetration by the fact that at this stage its moment is in the opposite sense to that of F_H . This condition may not obtain after a very few microseconds when the shot could be in an advanced state of ricochet, both forces having a moment in the same sense about the centre of gravity.

This is unlikely to happen at 45 degrees and fairly high velocities, if the shot remains whole, although it did happen in some cases to the DD shot which made shallow impressions and whose nose broke early during the attack. Moreover, although at the precise instant of impact at 45 degrees $F_V = F_H$, whatever the headshape of the shot a precise value cannot be stated of F_H at this instant, but only a constant mean value over the interval of observation.

A knowledge of the constants of a shot together with its velocity at any time, gives values of the shot's rotational and translational energy and therefore of the rate of working of the shot against the plate over this interval.

Let $2c$ = acceleration of the centre of gravity along the line of fire ($c < 0$)

$2\sqrt{\lambda}$ = angular acceleration of the shot ($\lambda > 0$)

m = mass of shot

I = moment of inertia of the shot about its transverse axis

V_s = striking velocity of shot

Then $F_H = 2mc$

Mean rate of working over interval $t = 2mc(V_s + ct)$

Moment of F_H and F_V about the centre of gravity = $2I\sqrt{\lambda}$

Mean rotational rate of working over an interval $t = 2\sqrt{\lambda}tI$

Translational energy at time $t = \frac{m}{2}(V_s + 2ct)^2$

Rotational energy at time $t = 2I\sqrt{\lambda}t^2$

Total energy at time $t = \frac{m}{2}(V_s + 2ct)^2$

Total mean rate of working over interval $t = 2mc(V_s + ct) + 2\sqrt{\lambda}It$

Figures are given for the above quantities except for the total energy and the total rate of working, these being almost the same as the translational energy and the translational rate of working over the interval considered (60 microseconds).

The results obtained by this method are too coarse to permit the performance of the different shot to be analysed in terms of them, but this coarseness is partly due to the nature of the shot themselves. With such a short shot the centre of gravity has very little distance to travel before the whole shot is largely obscured by debris from the plate and armour piercing cap. A longer shot would extend the range of observations with a resulting increase in accuracy. Moreover, the base of the shot presents an aspect to the camera from some angles causing an apparent slight enlargement of the shot in some positions. This enlargement can be up to 0.03 cms. and allowance has to be made for it.

The drawing out of the base of the shot due to the finite duration of the spark adds to the difficulty of pinpointing the centre of gravity. The removal or minimising of the last mentioned effects would increase the value of a determination of E_H and render feasible a direct measurement of E_V , for the latter depends far more than the former for its accuracy on a precise determination of the centre of gravity.

For if θ = angular deflection of the shot
 z = distance of the chosen point from the true centre of gravity along the axis of the shot, it can be shown that the resulting horizontal and vertical errors for the position of the centre of gravity are respectively

$$E_H = z \sin \frac{\theta}{2} \sqrt{2(1 - \cos \theta)}$$

$$E_V = z \tan \theta$$

the latter error being always larger than the former. For example, if $z = 0.1$ cm, $\theta = 10^\circ$

$$\text{then } E_H = 0.0015 \text{ cms}$$

$$E_V = 0.0176 \text{ cms}$$

Associated with the reaction R on the nose of the shot are four other stresses of interest viz. the bending moment Q , the shearing stress S , the tensile stress T , and the force F in the plane of the target which together with R determines the precessional motion of the centre of gravity of the shot.

By considering a rod under a force at one end (4) it is shown that the bending moment and shearing force at a distance z from the reaction are

$$\left. \begin{aligned} Q &= R \sin \theta z \left(1 - \frac{z}{L}\right)^2 \\ S &= \frac{-R}{A} \sin \theta \left(1 - \frac{4z}{L} + \frac{3z^2}{L^2}\right) \end{aligned} \right\} \begin{aligned} &\text{Where } L = \text{length of rod} \\ &R = \text{reaction on nose} \\ &\theta = \text{inclination of} \\ &\quad \text{reaction to shot axis} \\ &A = \text{cross sectional area.} \end{aligned}$$

The former has a maximum $\frac{4 RL \sin \theta}{27}$ at $z = \frac{L}{3}$

and the latter a maximum $\frac{R \sin \theta}{3}$ at $z = \frac{2L}{3}$

Typical values for these three shot would be

$$Q \text{ max} = \frac{3}{4} \text{ ton-wt-ft}$$

$$S \text{ max} = 20 \text{ tons wt/square inch}$$

Appendix VIII (b) illustrates that T at any point can be found as follows

Let G be the centre of gravity of AD
 " B " " " " " " AC
 " AD = L
 " AC = z
 " m = mass per unit length of rod
 " $\dot{\theta}(t)$ = angular velocity of the shot

Consider the acceleration of the point B along \overrightarrow{AG} .
 For the whole rod:- $\ddot{z} = \frac{R \cos \theta}{mL} + \frac{(L-z)}{2} \dot{\theta}^2$

For the portion AC:- $\ddot{z} = \frac{R \cos \theta - T}{mz}$

$$\therefore T(z) = R \cos \theta - z \left(\frac{R \cos \theta}{L} + \frac{m L \dot{\theta}^2}{2} \right) + \frac{mz^2 \dot{\theta}^2}{2}$$

$$= a - \frac{az}{L} + bLz + bz^2 \text{ say,}$$

so that for a given $\dot{\theta}$ we have a stationary value determined by

$$z = \frac{a}{-b} + \frac{L}{2}$$

Since $\frac{\partial^2 T}{\partial z^2} = 2b > 0$ and $\frac{a}{2bL} > 0$ for large $\dot{\theta}$ we have

a minimum of T at $z = \frac{L}{2}$

$$\text{Then } T \text{ min} = \frac{R \cos \theta}{2} - \frac{R^2 \cos^2 \theta}{2L^2 m \dot{\theta}^2} - \frac{mL^2 \dot{\theta}^2}{8} < T \left(\frac{L}{2} \right)$$

Typical values for the shot

R = 50 tons-wt.
 L = 2"
 m = 1.5 lbs/ft.
 $\dot{\theta}$ = 5000 radians/sec.
 $\cos \theta = 0.8$

give the order of T min as -40 tons - wt. approximately, the minus sign indicating a state of tension. The cross section of the shot is 0.49 square inches so the maximum tensile stress for the angular velocity is about 80 tons - wt./sq. inch.

At the moment of impact or maximum angular deflection, when the angular velocity of the shot is zero, the stress distribution in it will be as shown in Appendix VIII(c).

As the shot rotates, a tensile stress moves from the base towards the nose (its magnitude and velocity depending upon the angular velocity of the shot), the maximum of the wave tending to the position $z = \frac{L}{2}$ for high angular velocities (Appendix VIII(d))

then receding again to the base as the shot slows down.

At any time there is an unstressed section of the shot and the point marked P moves along the shot in a manner similar to the tensile stress.

$$\text{If } T(P) = 0 \text{ we have } P = \frac{2R \cos \theta}{L w \dot{\theta}^2}$$

For large $\dot{\theta}$, $P \rightarrow 0$ so that apart from impact wave reflections a large part of the shot is always under tension during the essential stages of penetration. Taking the typical values of the shot as shown above $P = 0.9$ cm approximately i.e. in the region between the nose and the shoulder of the shot. Superimposed upon the stresses is the elastic wave due to impact which takes approximately 10 microseconds to travel one shot length.

The nose can reflect as a free end or partially free end a tension wave from the base, but owing to the high velocity of the wave compared with that of the nose it would reflect a compression wave from the base as a fixed end.

Thus all wave reflections from the nose are in compression and all reflections from the base are in tension. Therefore just before 20 microseconds after impact there is 'interference' of the two stresses at the nose, and just after 20 microseconds after impact there is a reinforcement of compression waves. This reinforcement will take place every 20 microseconds, the magnitude of the impact component diminishing with successive reflections.

The force F, in the plane of the target arises from the consideration of the shot as a gyroscope. At a velocity of 2500 ft/sec the spin velocity of the shot is about 9000 radians/sec, and any force applied to the nose in the vertical plane and with a moment about the centre of gravity will cause the shot to precess about the axis of the force and the centre of gravity. This precession is in a clockwise direction looking along the line of fire from the gun. On striking the target, however, the nose of the shot is prevented from wandering over the face of the plate due to the indentation made by the nose on impact, and the force F causes the centre of gravity of the shot to precess, still in a clockwise direction.

10. Conclusions

The general conclusions agree with those published in A.R.E. Report 19/50 and are as follows:-

At 45° angle of attack, an ogive with a pointed tip such as DD, gives a poorer penetrative performance than types DE and DF in which the points have been suppressed, the reasons being that with the latter types

- (a) plate perforation takes place at a slightly lower velocity.
- (b) break up of the shot takes place at a later stage of the perforation process.

Greater protection against nose breakage is obtained by using heavy alloy cups in place of the normal hardened steel ones of the same thickness, when fitted to the DF type of shot.

SECRET

Shot which have been carefully scaled down from 6 pr. to 20 mm. calibre give results which are in very good agreement with the full scale trials when the appropriate scale factor is applied.

11. Recommendations

The following further work is proposed:-

- 11.1 A more complete investigation of the blunt nosed type of shot, without a cap, for t/d ratios approximately equal to 1, keeping the angle of attack constant.
- 11.2 Longer shot could be used in order to observe the progress of the centre of gravity over an increased period of time, and also to obtain more information about the turning of the shot in the later stages of penetration when it swings back towards the normal of the plate. The longer shot would also turn more slowly.
- 11.3 By fitting heavy alloy caps of varying shapes and thicknesses a condition may be found which will give the maximum protection to the nose against breakage, and a minimum turning of the shot away from normal.
- 11.4 A new type of spark rack and camera is being designed which will reduce to a minimum, trouble caused by aspect of the base of the shot at certain angles, and a new spark gap with a point source and reduced spark duration (described in A.R.E. Memo. 21/52)⁽³⁾ will be incorporated. This new layout will enable more accurate measurements to be made, and so lead to an increased value of the determination of the forces acting on the nose of the shot.

12. Bibliography

<u>Page</u>	<u>Ref.</u>	<u>Title</u>
1 11	(1)	ARE Report 19/50. The Variation in Penetrative Performance of A.P. (Steel) Capped Projectiles of varying Head Shapes, against Armour. Major D.B.B. Janisch, R.A., Major H.W. Whent, R.A.
5	(2)	ARE Report 3/51. High Obliquity Attack of Deck Targets, Part III. H.F. Hills.
20	(3)	ARE Memo 21/52. An improved Spark Gap of Small Dimensions for Fast Shadow Photography. H.F. Hills.
17	(4)	Ordnance Board 1950. The Penetration of Armour Plate, Chapter 3. C.A. Adams.

13. Photographs

Reproduction of selections from some of the sets of photographs illustrate this report.

The Multiple Spark photographs are silhouettes of what is occurring in front of a lens of 20 inches diameter.

Each photograph of one set of twenty five is taken from a slightly different viewpoint.

In these photographs the plates appear thicker than they should do. As the plates are four and a half inches wide, a lens position slightly out of the plane of the plate will, by perspective, cause the plate to appear greater than its real thickness.

The gun is laid so that the line of flight of the projectile before impact is horizontal.

PLATE I

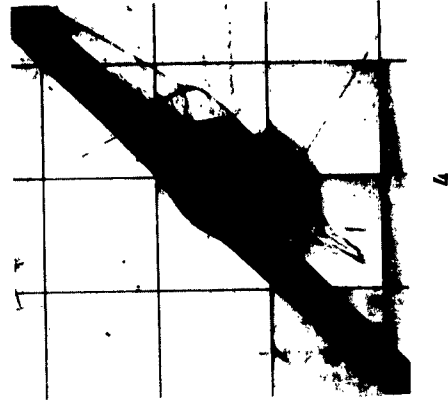
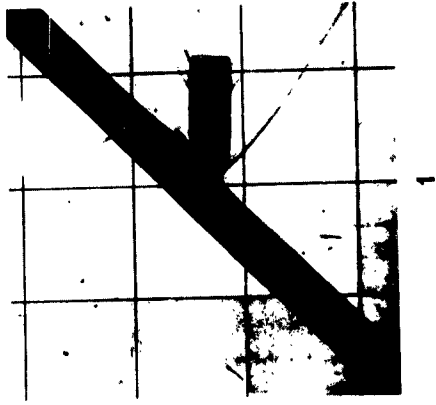

CONFIDENTIAL

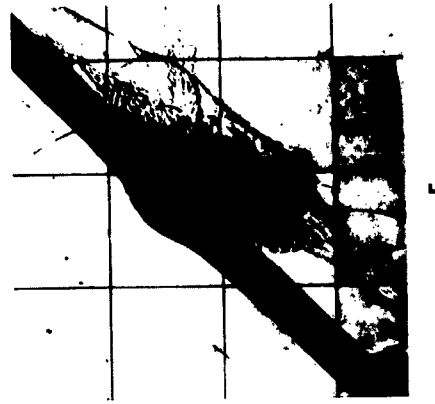
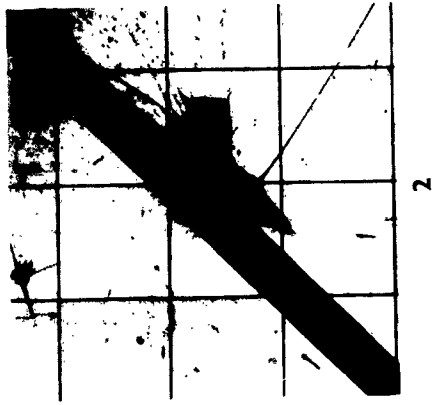

ROUND 281

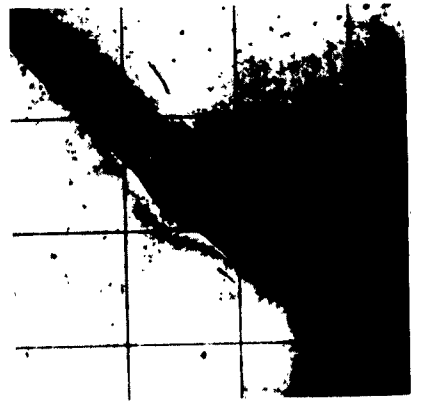
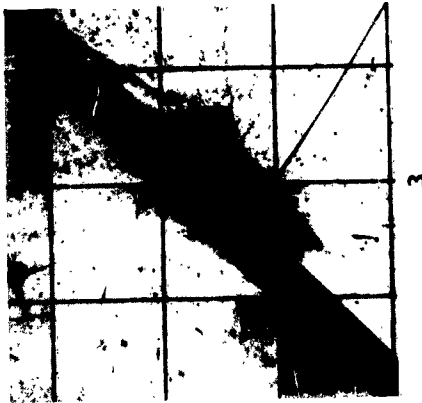

ROUND 280

CONFIDENTIAL

PLATE 2

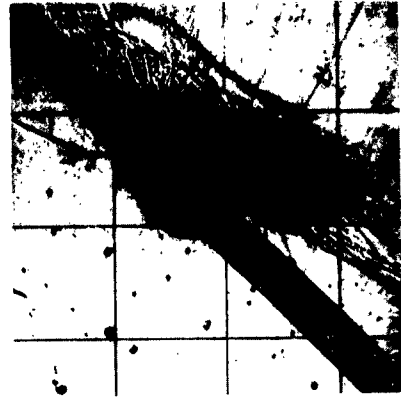
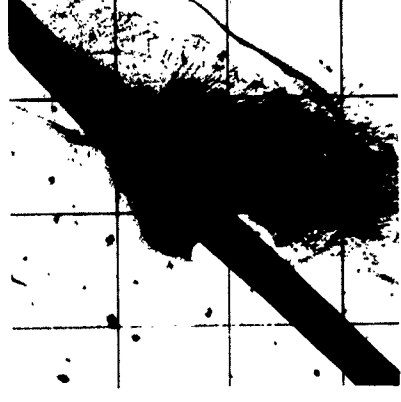
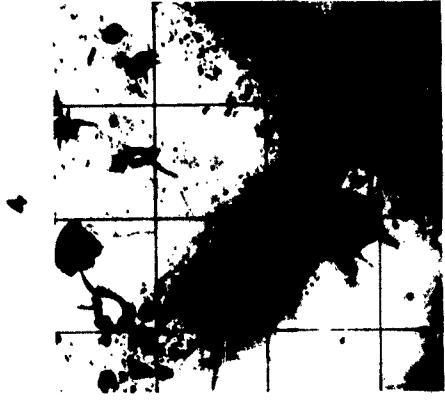

CONFIDENTIAL

PLATE 3



ROUND 279

ROUND 280

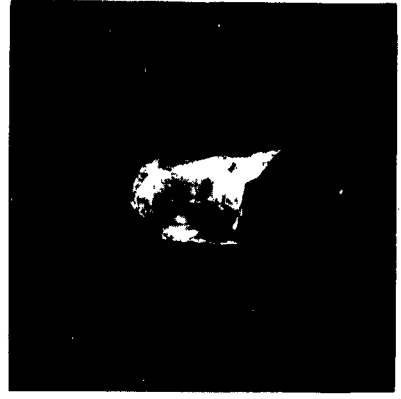

A

B

PLATE 3A

CONFIDENTIAL



ROUND 284



ROUND 285



ROUND 285

CONFIDENTIAL

PLATE 4

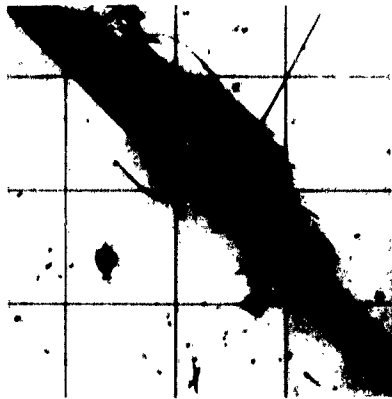

4

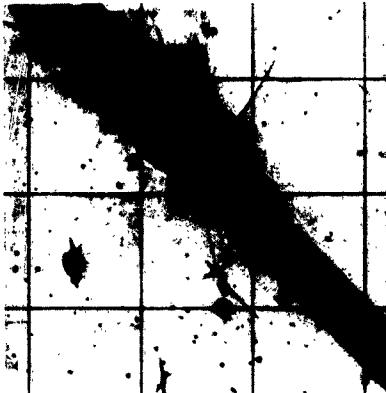

3



2



1



8



7

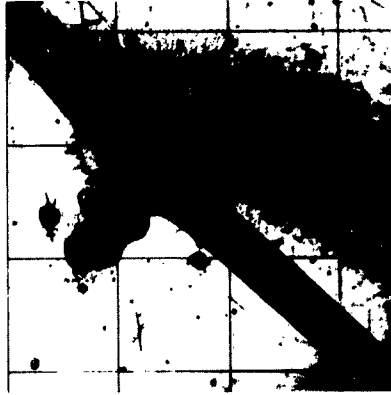

6



5

PLATE 5

CONFIDENTIAL

ROUNDS 286 & 287

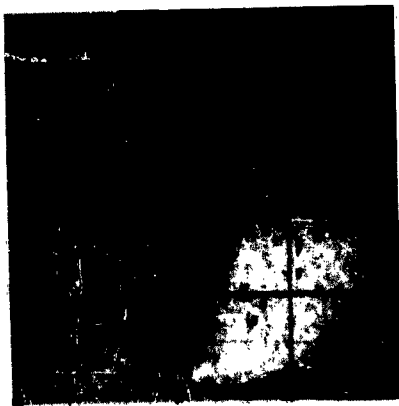
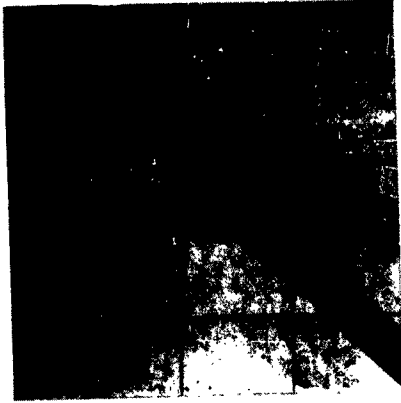

1

2

3

4

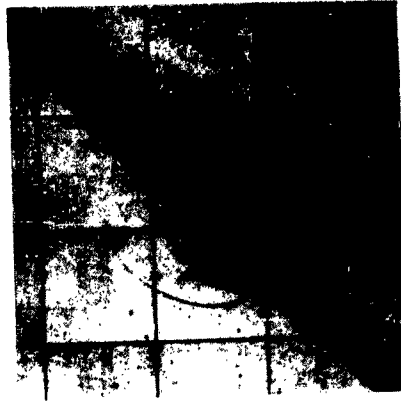

1

2

3

4

ROUNDS 291 & 292

CONFIDENTIAL

PLATE 6

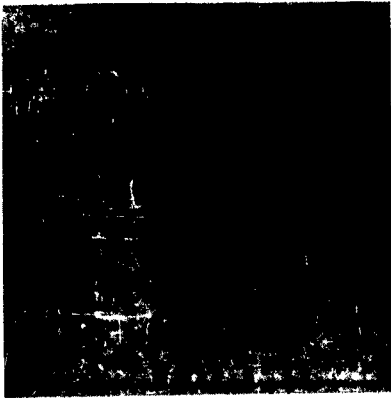

4



3



2



1



4



3

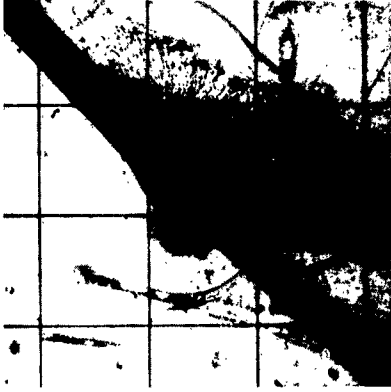

2

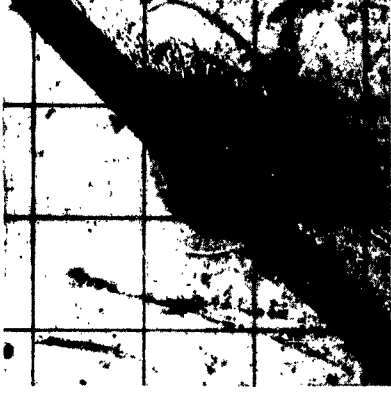

1

ROUNDS 288 & 289

CONFIDENTIAL

PLATE 7

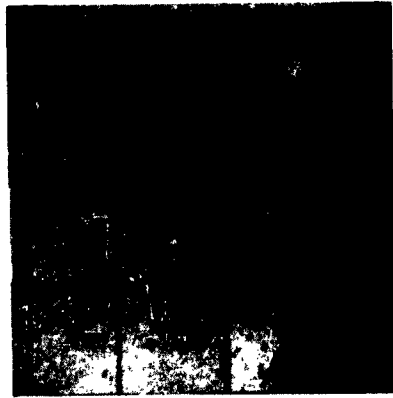

4



3



2



1



4



3

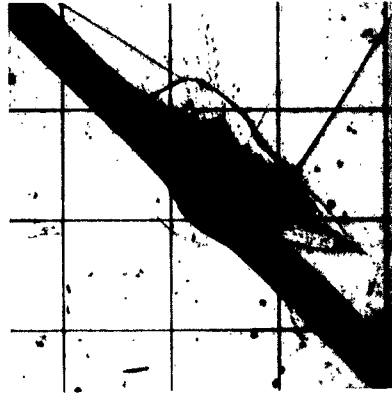

2

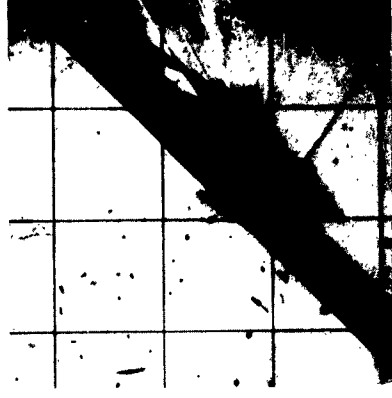

1

CONFIDENTIAL

ROUND 290

PLATE 8



4



3



2



1

PLATE 9

CONFIDENTIAL

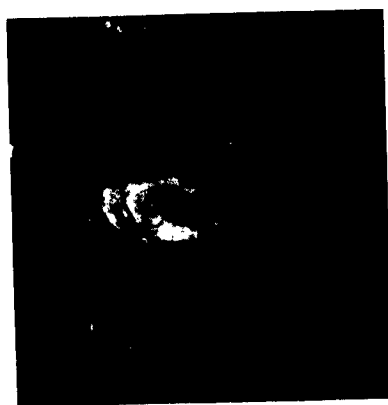
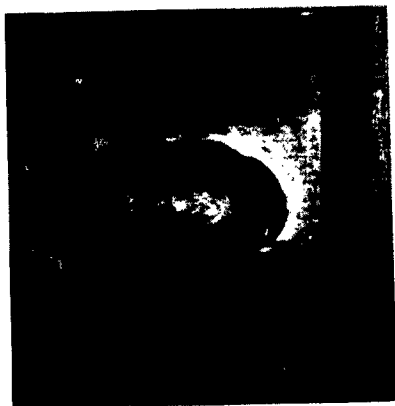
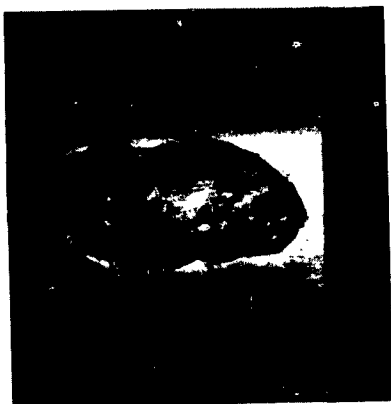

ROUND 289

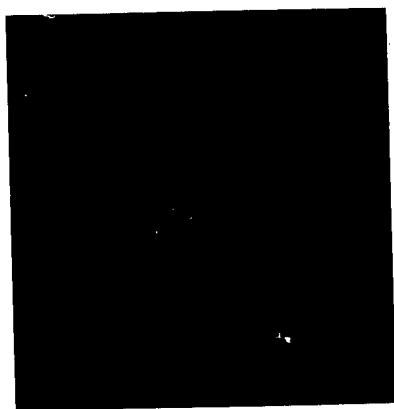

ROUND 288

CONFIDENTIAL

PLATE 9A

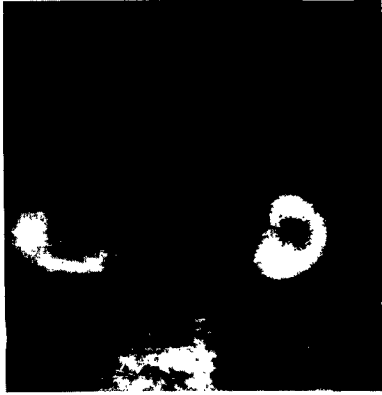
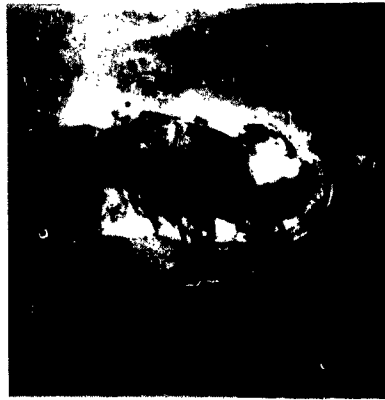

ROUND 290



ROUND 292

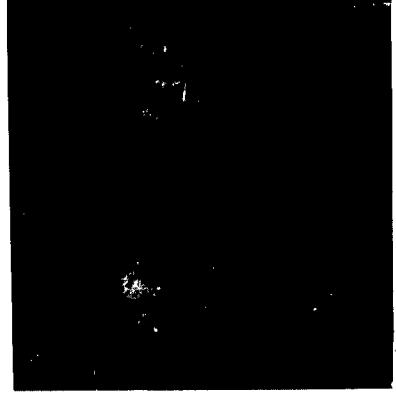

PLATE 10

CONFIDENTIAL

ROUND 295

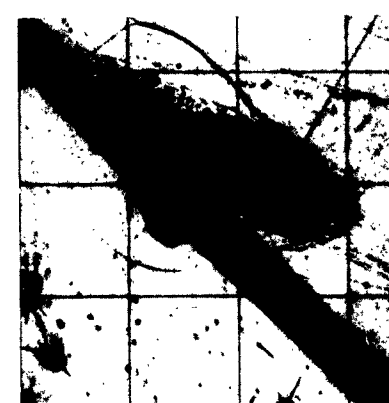
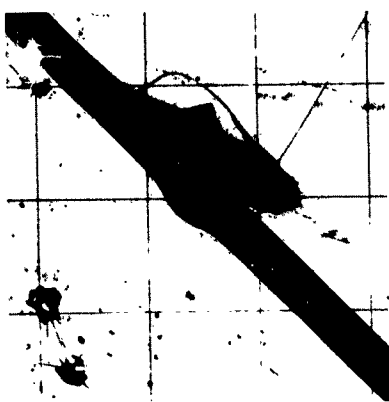
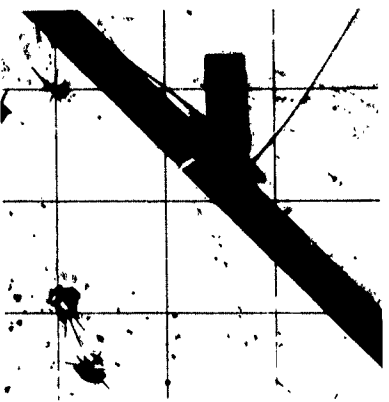
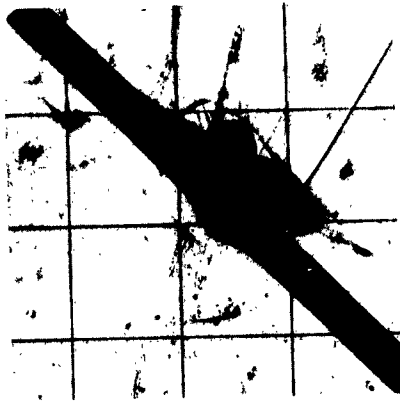

PLATE II

CONFIDENTIAL

ROUND 293



1

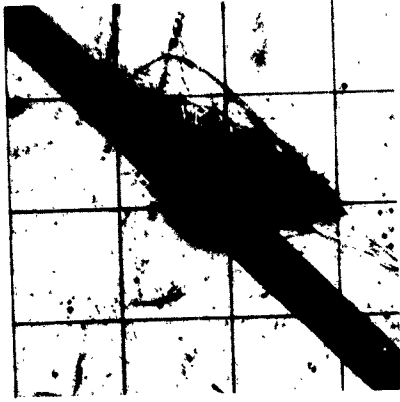

2



3



4

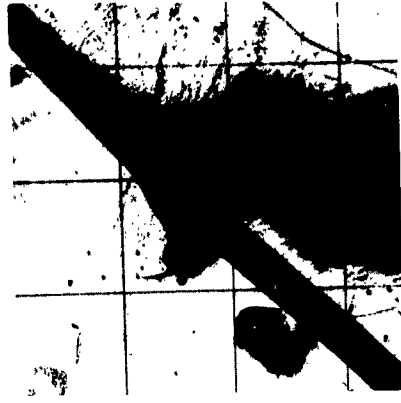

5



6



7

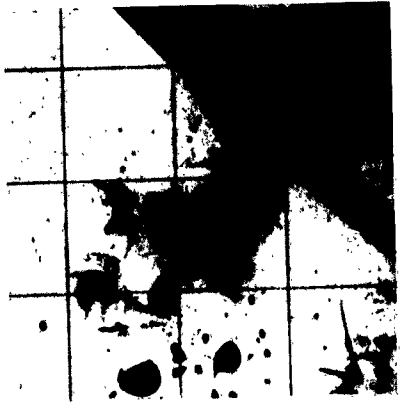

8

PLATE 12

CONFIDENTIAL

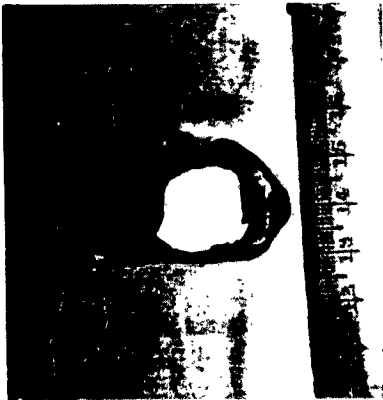

ROUND 294



ROUND 293

PLATE 12A

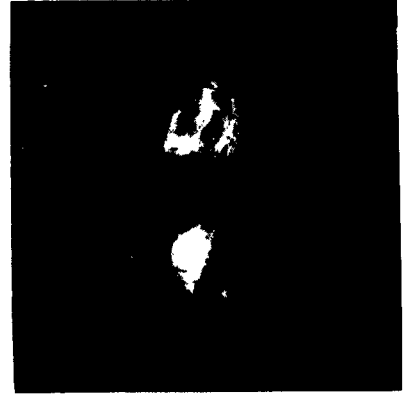

ROUND 297



ROUND 295

ROUND 325

CONFIDENTIAL

PLATE 13

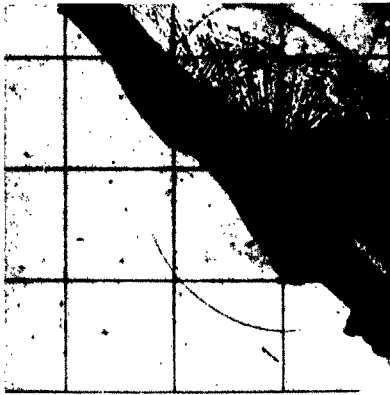

4

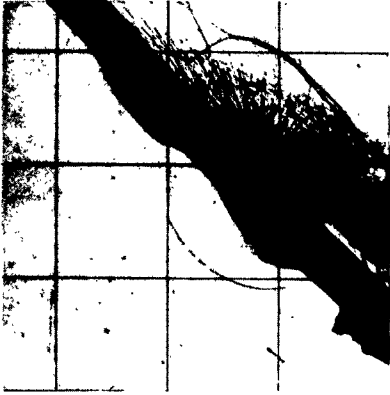

3



2



1



8



7



6

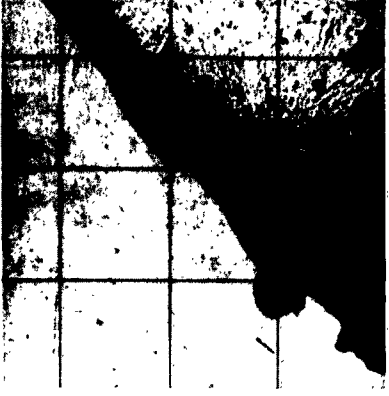

5

CONFIDENTIAL



ROUND 323

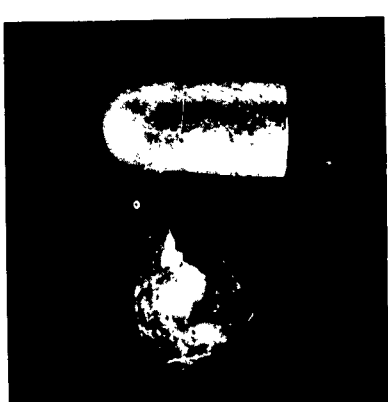

ROUND 322

PLATE 14A

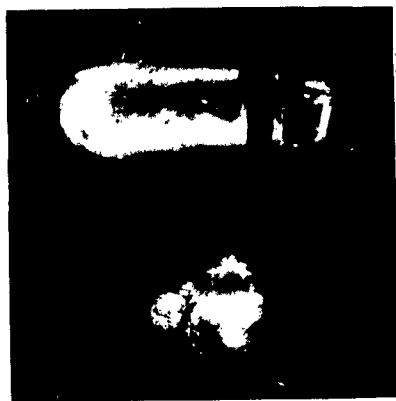
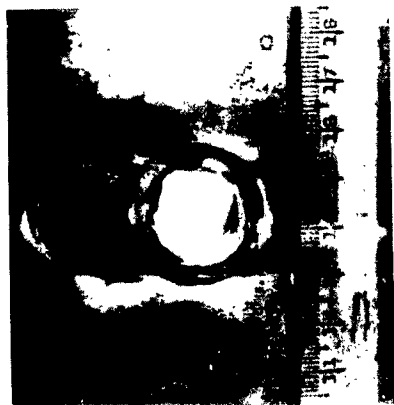

ROUND 325



ROUND 324

PLATE 15

CONFIDENTIAL

ROUND 295

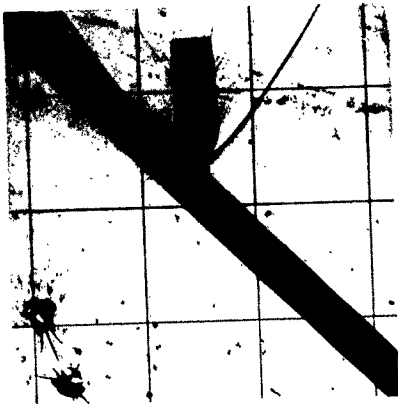

ROUND 294

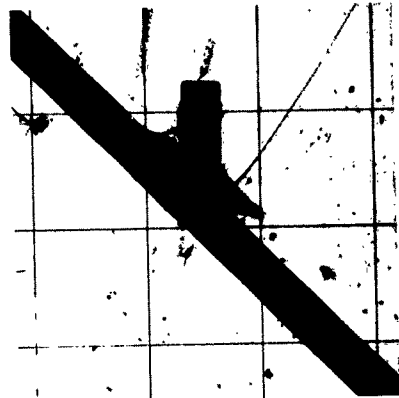

SECRET

APPENDIX I
DETAILS OF EXPERIMENTAL SHOT.

SCALE 2/1

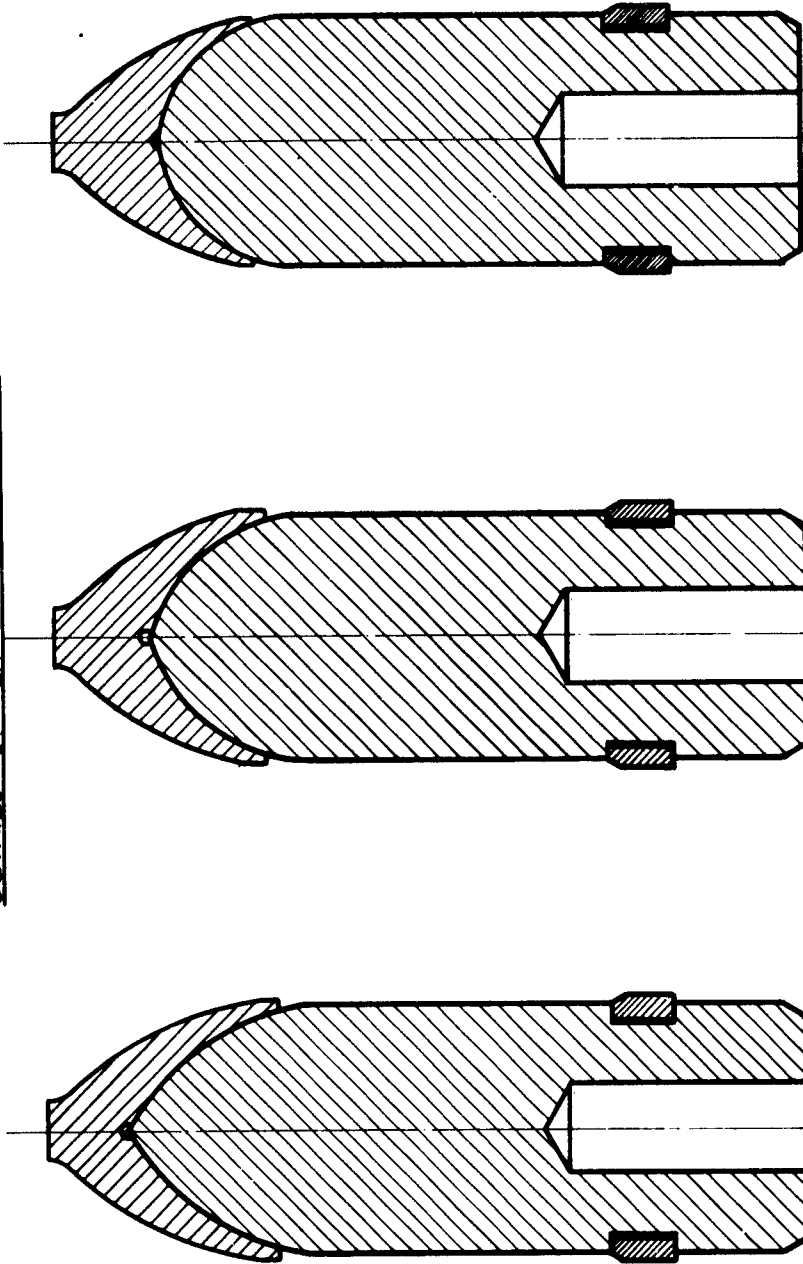

CODE LETTER OF SHOT	D.D.	D.F.	D.F.
DRAWING N°	A.R.D./B.G./N° 6558	A.R.D./B.G./N° 6560	A.R.D./B.G./N° 6551
C.R.H.	1.0	0.7	0.57
RADIUS OF POINT.	NIL.	NIL.	NIL.
REMARKS.			NOSE IS ALMOST HEMISPHERICAL.

SECRET

APPENDIX II

DETAILS OF PLATE	DESCRIPTION OF SHOT	SHOT CODE	HOLE 20% AND OVER THROUGH	HOLE 20% AND OVER THROUGH	HOLE LESS THAN 20% THROUGH	SCOP CRACKED BULGE	SCOOP SMOOTH BULGE	# DENT SMOOTH BULGE	STRIKING VELOCITY-Ft/SEC.
18.5mm. IT 80 BHN 305	APC	DD	○ 278	○ 277	○ 281		○ 283 ○ 282 ○ 284	● 279	● 285
18.5mm. IT 80 BHN 320	APC	DE	○ 288		○ 289 ○ 292 ○ 290	● 294 ● 287	● 286		
45° ATTACK	APC	DF	○ 300		● 299	○ 297	● 298		
					● 294 ● 296 ● 293	● 295			
	APC (HEAVY ALLOY CAP)	DF		○ 325 ○ 324	● 322	● 322		● 323	

APPENDIX III.

SECRET.

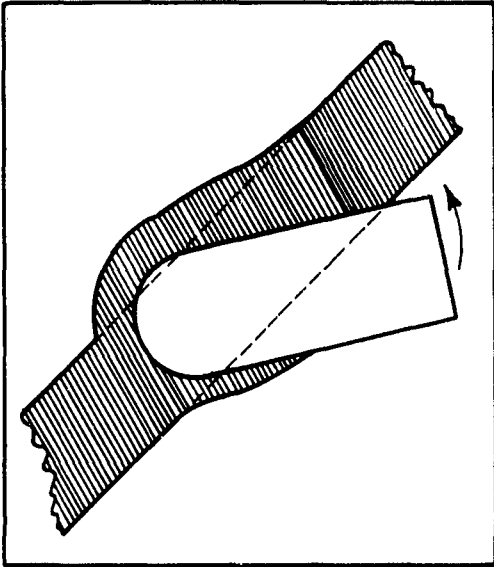

b

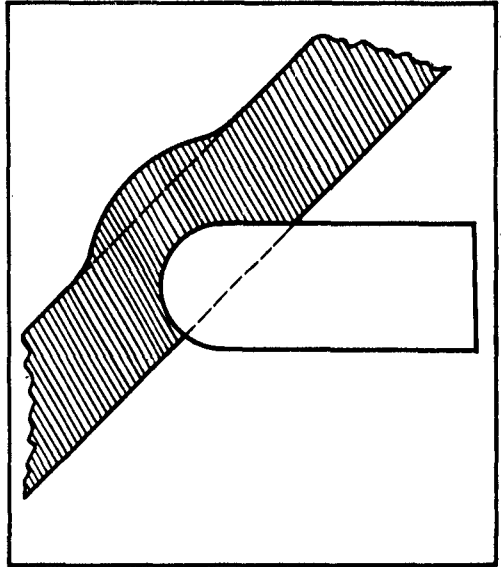

a

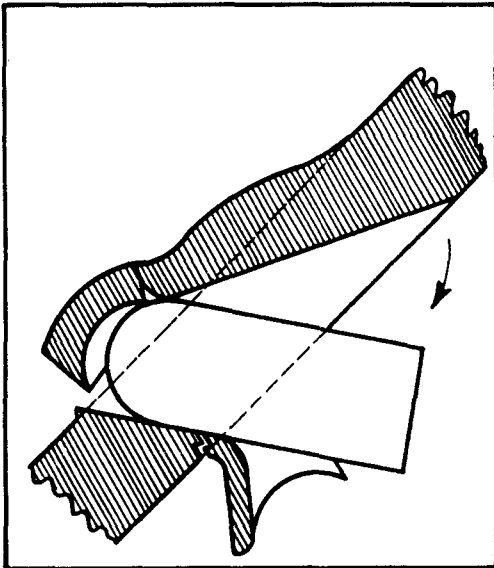

d

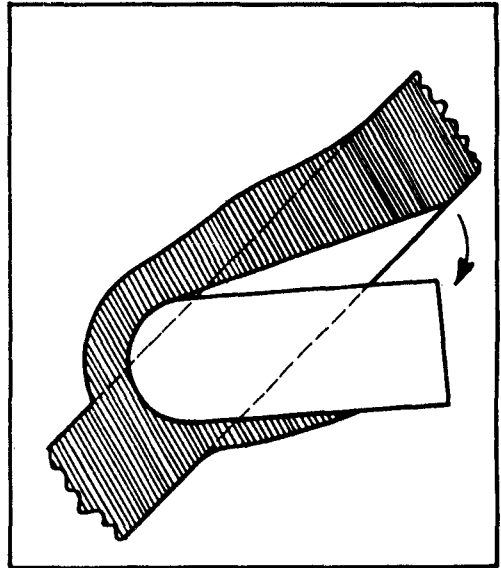

c

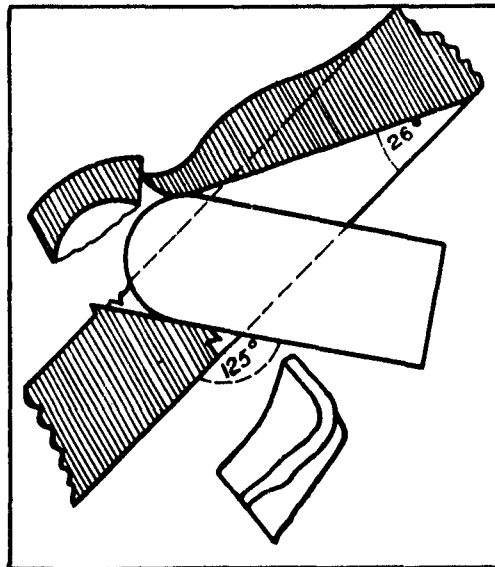

e

SECRET.

SECRET

APPENDIX IV

ROUND NO 282

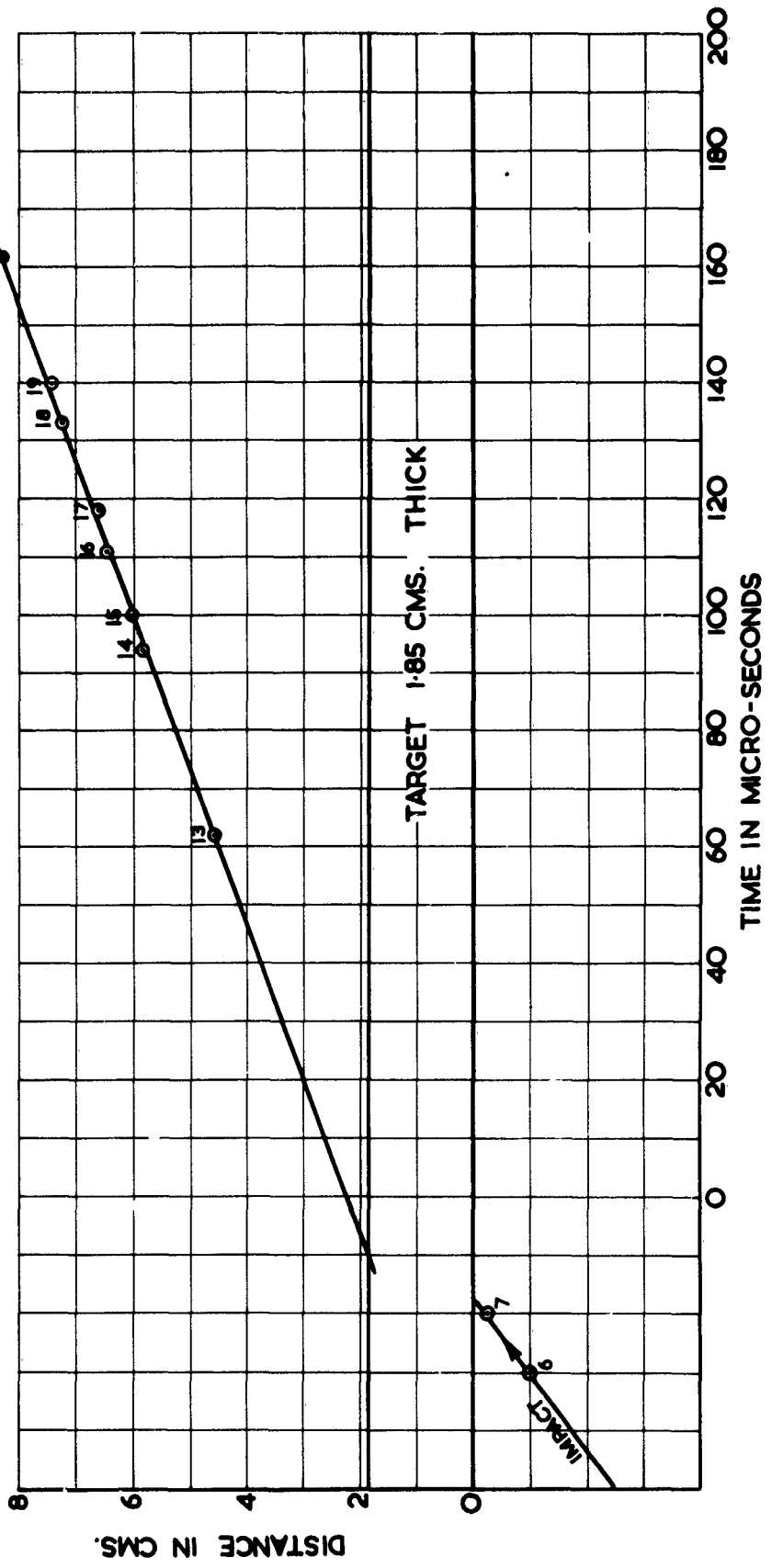

SECRET

SECRET.

APPENDIX V

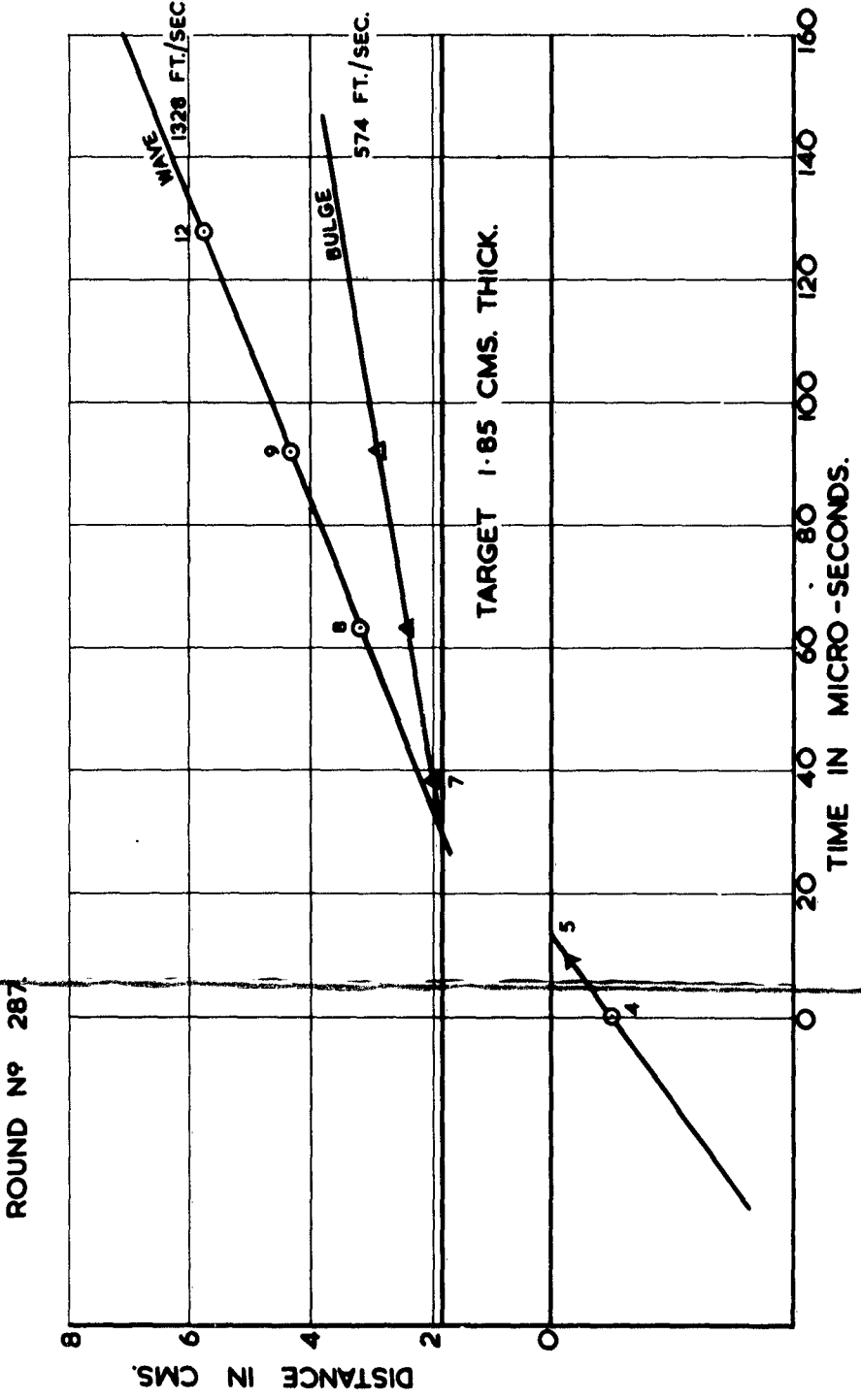

SECRET.

APPENDIX VI

ROUND N° 295

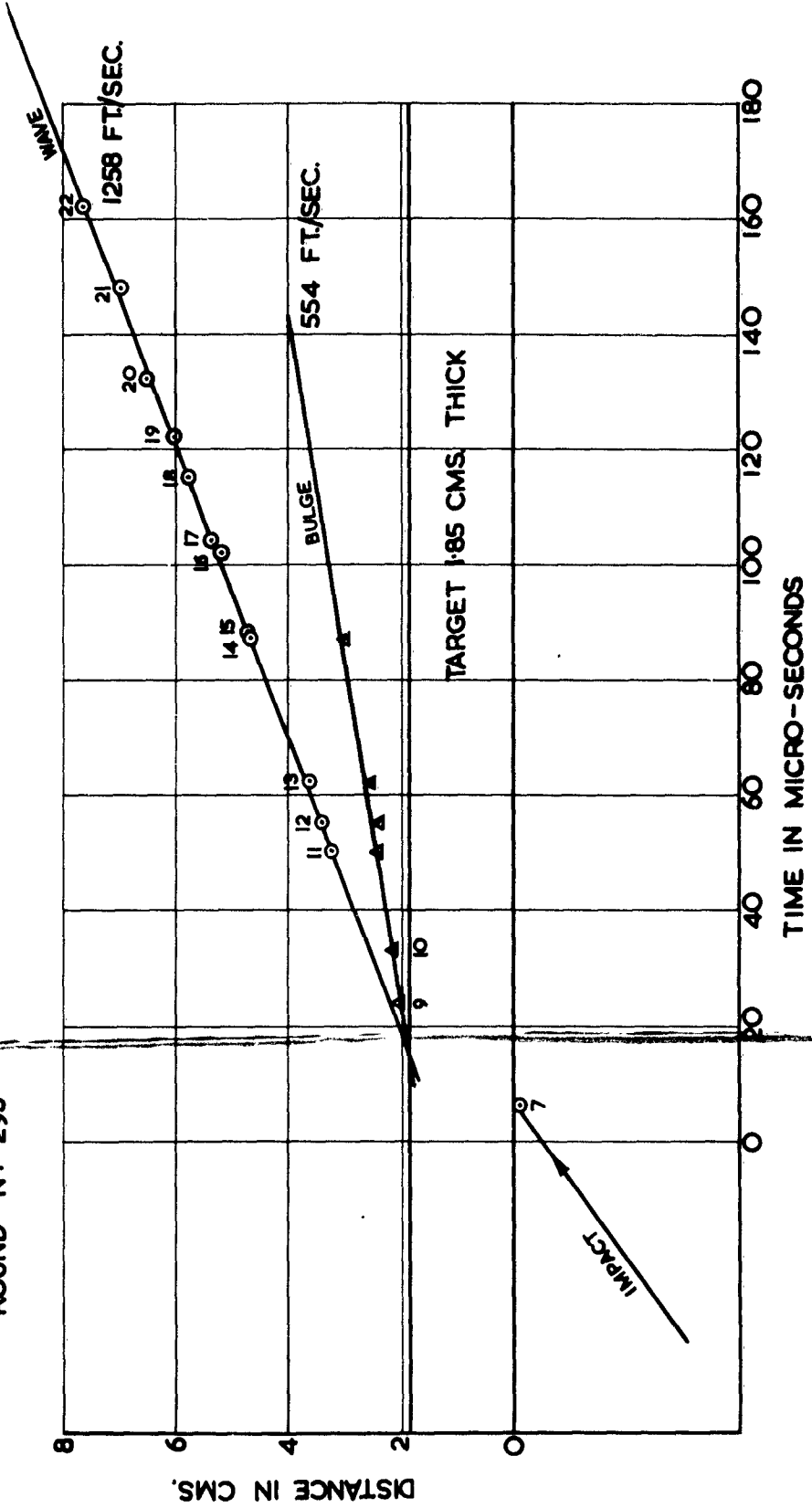

APPENDIX VII

SECRET

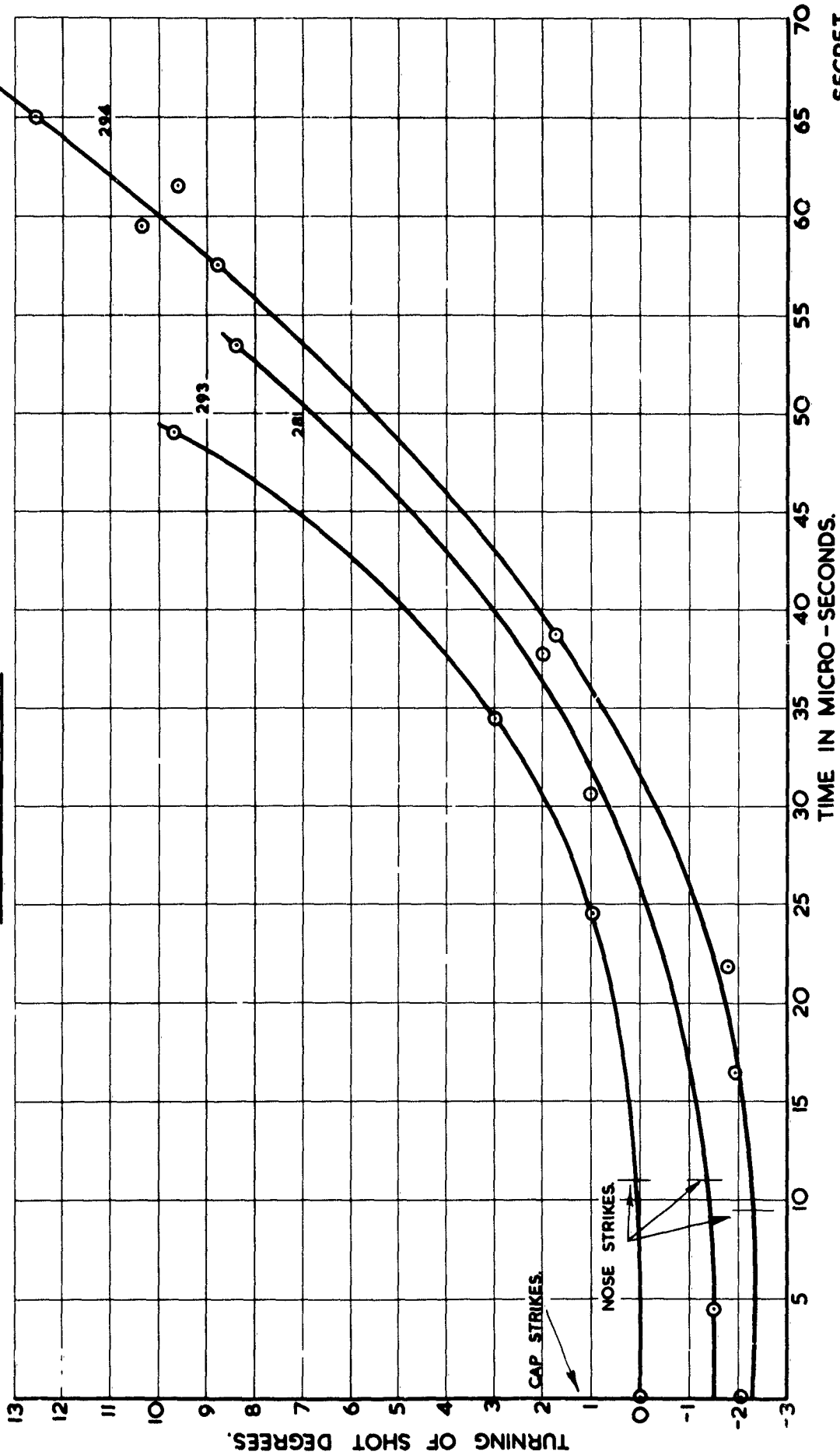

SECRET

APPENDIX VIII

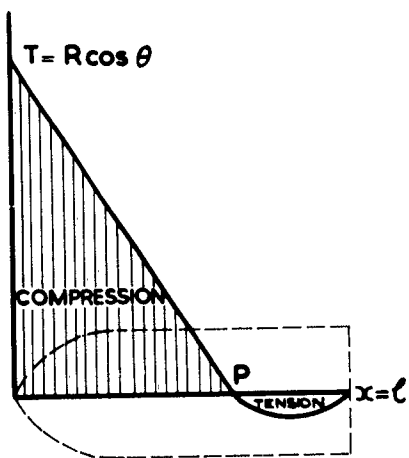
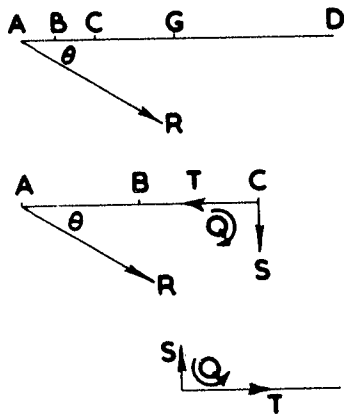
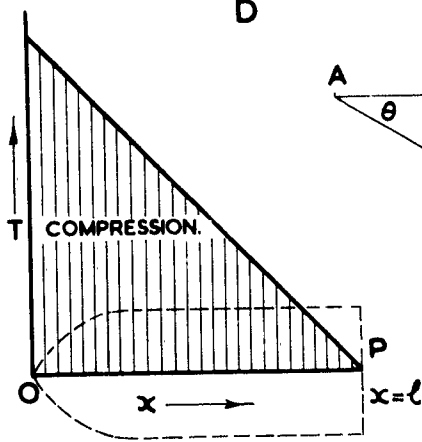
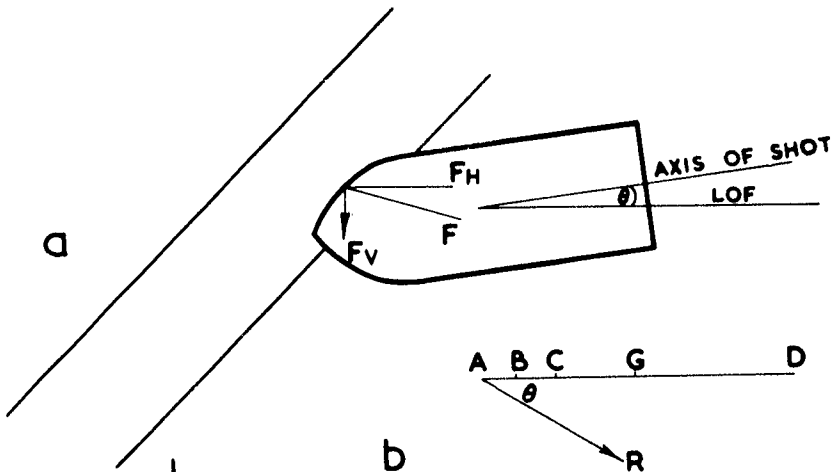

c

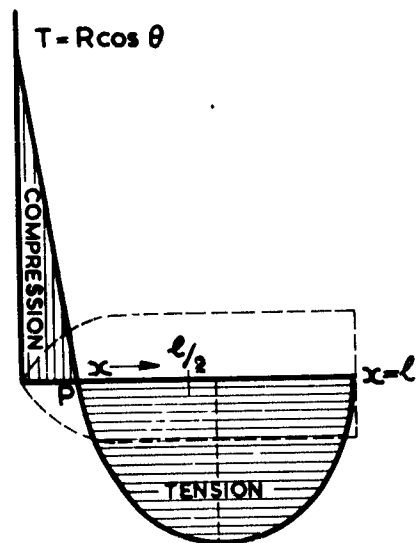

d

SECRET.

APPENDIX IX

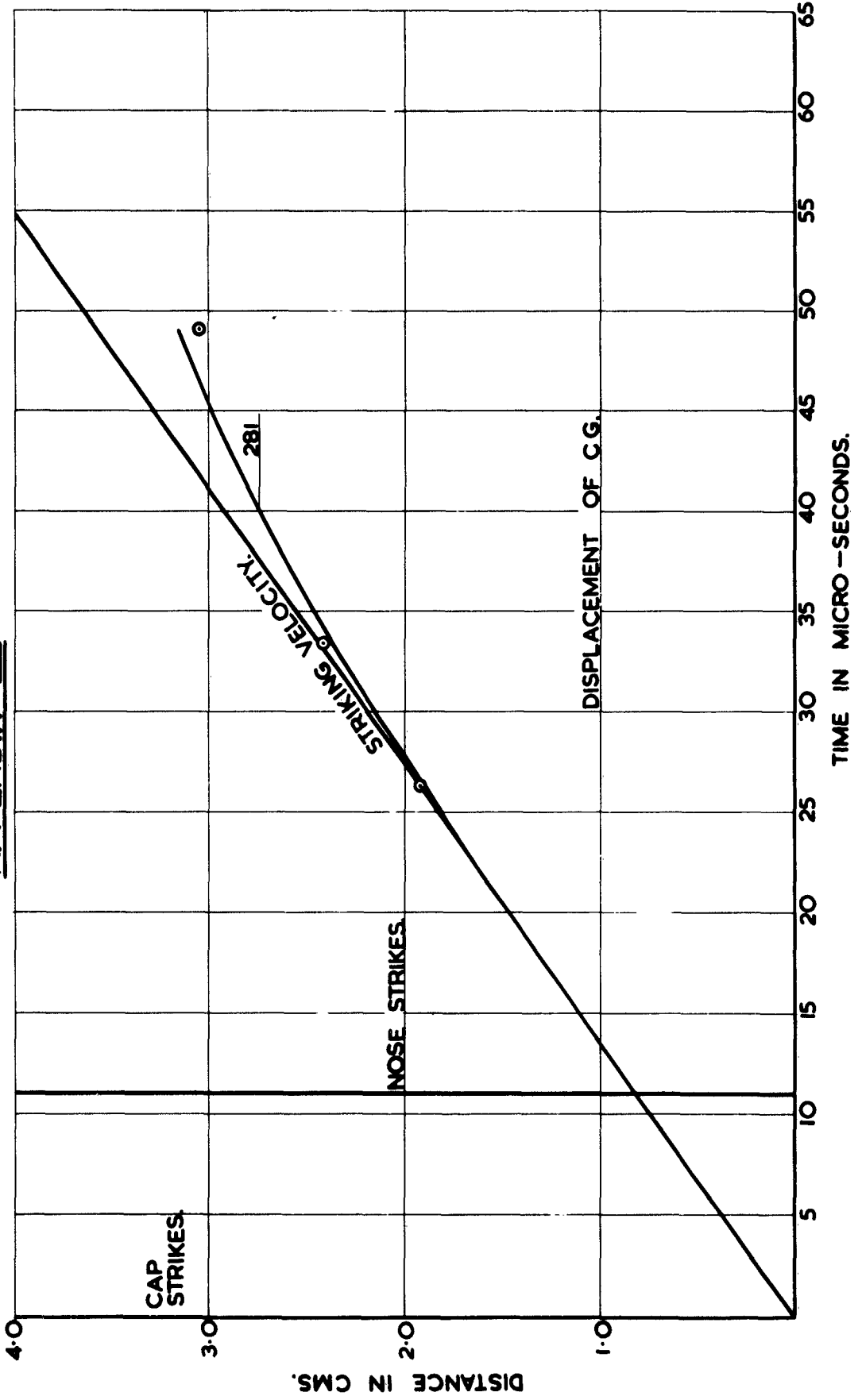

SECRET.

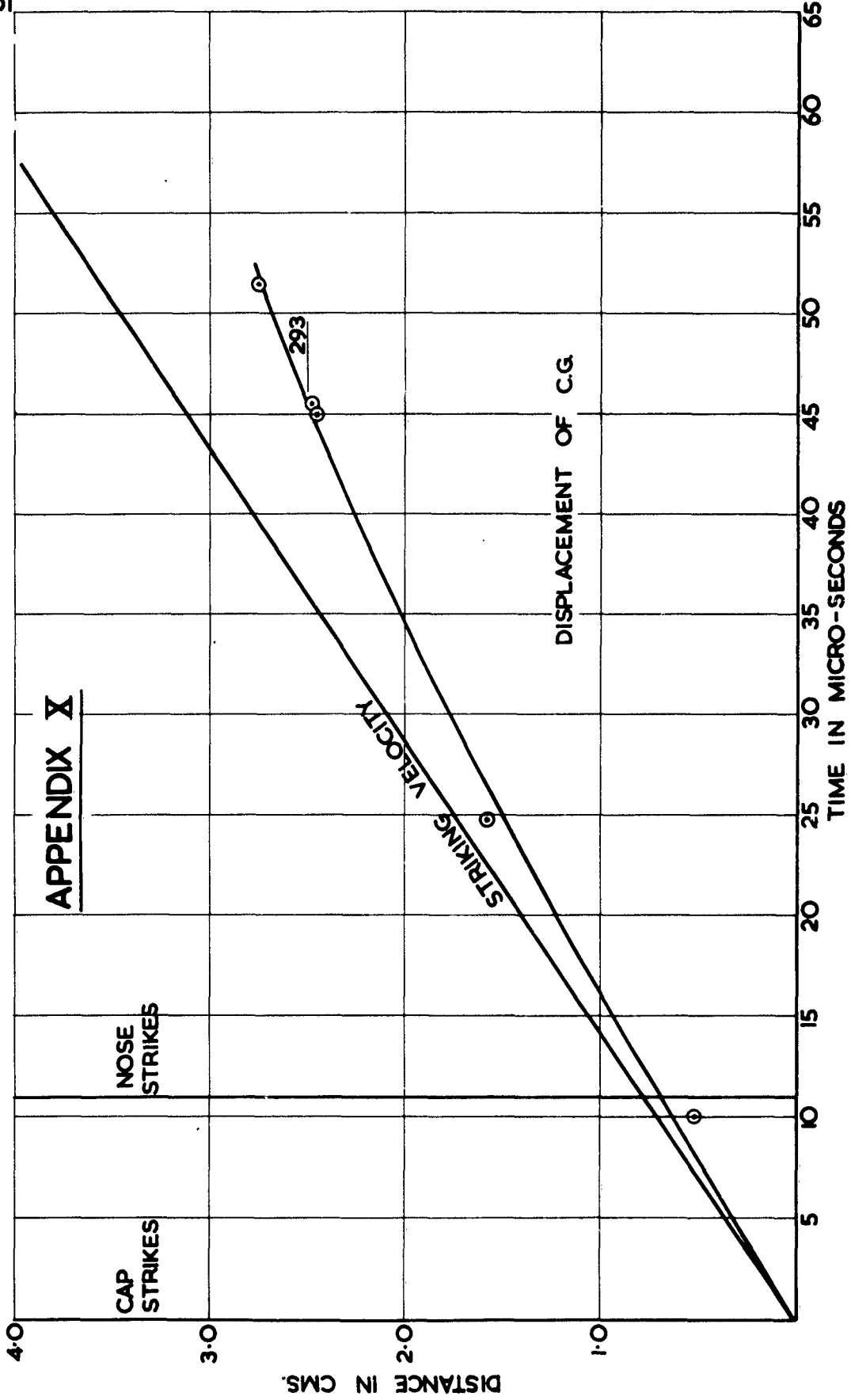

APPENDIX X

NOSE STRIKES

CAP STRIKES

APPENDIX XI

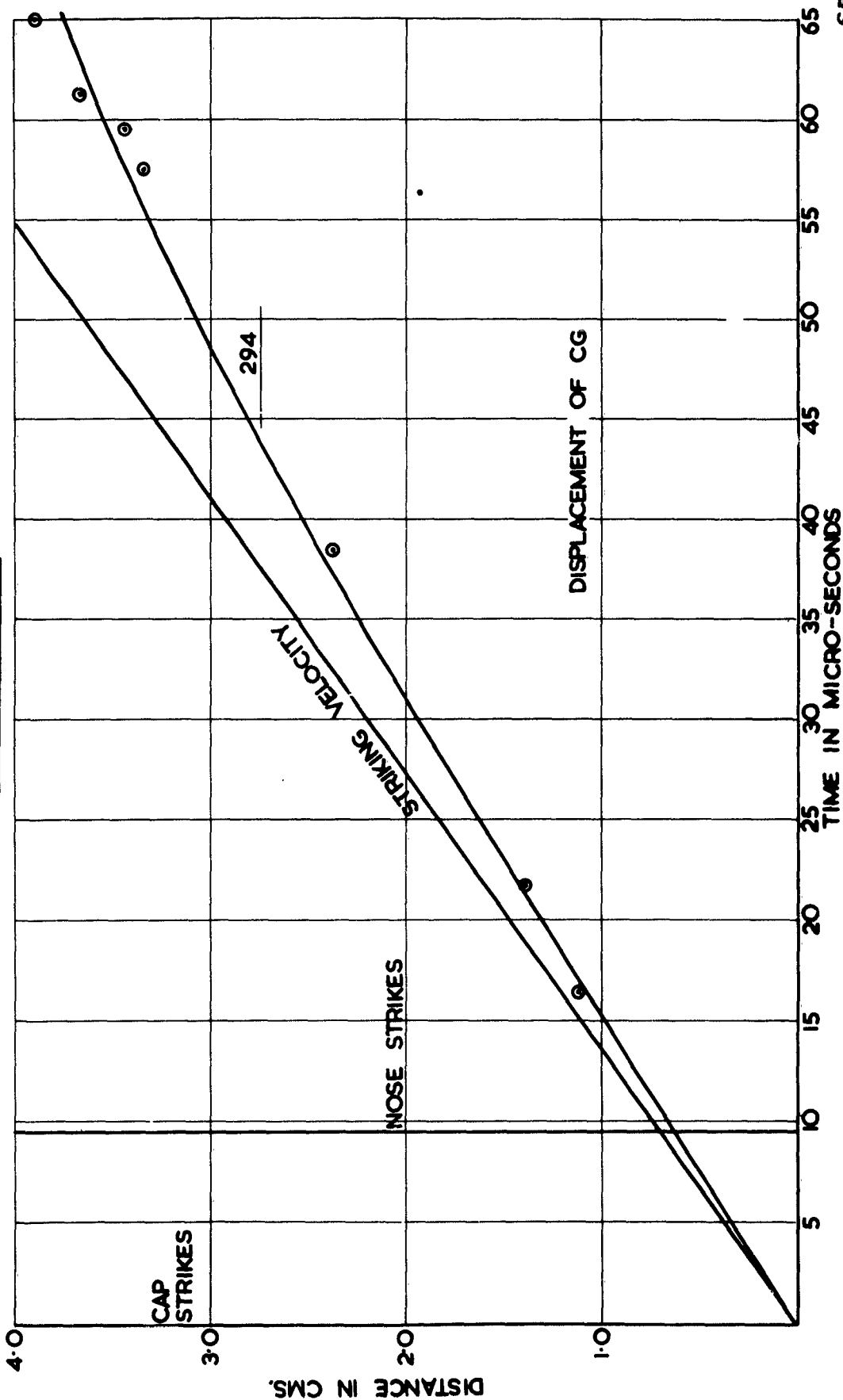

Appendix XII

Summary of Firing Results

Round No.	Armour Plate				Projectile			
	Angle of Attack	Thick-ness I.T. 80 mm.	No.	B.H.N.	Length of scoop on front of target plate	Damage	S.V. ft/sec	Type of Shot
277	45°	18.5	5280	305	5.8 cms.	Break up	2310	DD
278	"	"	"	"	3.8 "	" "	2256	"
279	"	"	"	"	3.6 "	" "	2666	"
280	"	"	5392	"	5.6 "	" "	2534	"
281	"	"	"	"	4.1 "	" "	2400	"
282	"	"	"	"	4.3 "	" "	2515	"
283	"	"	"	"	4.1 "	" "	2534	"
284	"	"	"	"	4.6 "	" "	2578	"
285	"	"	"	"	4.1 "	" "	2769	"
286	"	"	5280	"	5.1 "	" "	2581	DE
287	"	"	"	"	5.8 "	" "	2472	"
288	"	"	5399	310	5.6 "	" "	2348	"
289	"	"	"	"	5.6 "	" "	2416	"
290	"	"	"	"	5.8 "	" "	2407	"
291	"	"	"	"	5.1 "	" "	2481	"
292	"	"	"	"	5.3 "	" "	2458	"
293	"	"	"	"	5.3 "	" "	2445	DF
294	"	"	"	"	5.3 "	Whole	2394	"
295	"	"	"	"	4.1 "	Break up	2452	"
296	"	"	"	"	5.1 "	Lodge	2418	"
297	"	"	"	"	4.6 "	Whole Break up	2441	"
298	"	"	"	"	5.6 "	" "	2576	"
299	"	"	2419	375	4.3 "	" "	2380	"
300	"	"	5399	320	5.1 "	" "	2250	"
322	"	"	"	"	5.3 "	Whole	2453	DF
323	"	"	"	"	4.5 "	"	2799	With
324	"	"	"	"	5.3 "	"	2407	Heavy
325	"	"	"	"	5.5 "	"	2386	Alloy Cap



*Information Centre
Knowledge Services*
[dstl] Porton Down,
Salisbury
Wiltshire
SP4 0JQ
22060-6218
Tel: 01980-613753
Fax 01980-613970

Defense Technical Information Center (DTIC)
8725 John J. Kingman Road, Suit 0944
Fort Belvoir, VA 22060-6218
U.S.A.

AD#: AD029525

Date of Search: 1 August 2008

Record Summary: DEFE 15/1041

Title: Steel projectiles for defeat of armour at large angles of attack
Availability Open Document, Open Description, Normal Closure before FOI Act: 30 years
Former reference (Department) Report No 30/53
Held by The National Archives, Kew

This document is now available at the National Archives, Kew, Surrey, United Kingdom.

DTIC has checked the National Archives Catalogue website (<http://www.nationalarchives.gov.uk>) and found the document is available and releasable to the public.

Access to UK public records is governed by statute, namely the Public Records Act, 1958, and the Public Records Act, 1967.

The document has been released under the 30 year rule.

(The vast majority of records selected for permanent preservation are made available to the public when they are 30 years old. This is commonly referred to as the 30 year rule and was established by the Public Records Act of 1967).

This document may be treated as UNLIMITED.