

UNCLASSIFIED

Defense Technical Information Center  
Compilation Part Notice

ADP023078

TITLE: ModSAF-Based Development of DAS for Light Armoured Vehicles

DISTRIBUTION: Approved for public release, distribution unlimited

This paper is part of the following report:

TITLE: Proceedings of the Ground Target Modeling and Validation Conference [13th] Held in Houghton, MI on 5-8 August 2002

To order the complete compilation report, use: ADA459530

The component part is provided here to allow users access to individually authored sections of proceedings, annals, symposia, etc. However, the component should be considered within the context of the overall compilation report and not as a stand-alone technical report.

The following component part numbers comprise the compilation report:

ADP023075 thru ADP023108

UNCLASSIFIED

# ModSAF-based development of DAS for light armoured vehicles

John Rapanotti\* and Marc Palmarini†

\*Defence Research and Development Canada – Valcartier, Val-Bélair (QC), G3J 1X5

†Onix Integration Inc., Ste-Foy (QC), G1V 4P1

## ABSTRACT

Light Armoured Vehicles meet the requirement for rapid deployment by replacing passive armour with sensors, computers and countermeasures to detect and avoid threats. This emphasis on threat avoidance in an environment of increasing operational tempo results in major issues including: cognitive overload, training and skill decay and the significance of the man-machine interface. Modelling and simulation play an important role in these developments.

The integration of various technologies into a Defensive Aids Suite (DAS) can be designed and analyzed by combining field trials and laboratory data with modelling and simulation. ModSAF (Modular Semi-Automated Forces), is used to construct the virtual battlefield and, through scripted input files, a “fixed battle” approach is used to define and implement contributions from three different sources. These contributions include: models of technology and natural phenomena from scientists and engineers, tactics and doctrine from the military and detailed analyses from operations research. This approach ensures the modelling of processes known to be important regardless of the level of information available about the system. Survivability of DAS-equipped vehicles based on future and foreign technology can be investigated by ModSAF and assessed relative to a test vehicle. A system can be modelled phenomenologically until more information is available.

ModSAF is being developed for research and development, in addition to the original requirement of Simulation and Modelling for Acquisition, Rehearsal, Requirements and Training (SMARRT), and is becoming useful as a means for transferring technology to other users and researchers. This procedure eliminates the need to construct ad hoc models and databases. These concepts and approach will be discussed in the paper.

## 1. INTRODUCTION

Modern weapons have reduced the traditional effectiveness of passive armour on land vehicles. Portable missiles with warheads containing multiple shape charges can penetrate any thickness of armour. Sensor-fuzed munitions and top-attack missiles are designed to penetrate the more vulnerable turret. Artillery, instead of rocket motors, can be used to launch guided missiles that cannot be detected by missile approach warning systems searching for rocket plumes. The solution is therefore to avoid detection as long as possible by various means including camouflage and by reducing vehicle signatures to background levels. Survivability can be further increased by the early detection of threats followed by appropriate and timely countermeasures to either defeat the threat directly or to reduce the effectiveness of the guidance system.

A vehicle designed to survive these modern threats has to rely less on passive armour and more on sensors, computers and countermeasures. The long service life of the vehicle, typically 50 years, can also be a problem unless the vehicle is designed to accept upgrades. An approach to develop and maintain the survivability of the vehicle through a series of upgrades based on identified technological trends is discussed in this paper.

To better understand, evaluate and develop threat avoidance, realistic evaluations are carried out, in a context useful and relevant to the military, on a virtual battlefield. ModSAF (Modular Semi-Automated Forces) is used to construct the virtual battlefield and to model and simulate DAS<sup>1-3</sup> on light armoured vehicles. The DAS and LAV configurations being evaluated are described in more detail below.

Modelling physical systems in ModSAF is not new. Terrain features are represented in sufficient detail to study vehicle mobility, detection, deflame and other practical manoeuvres. Atmospheric phenomena are modelled to produce accurate effects of attenuation over distance, scattering by smoke and dust and insolation. Spectral effects in the atmosphere, such

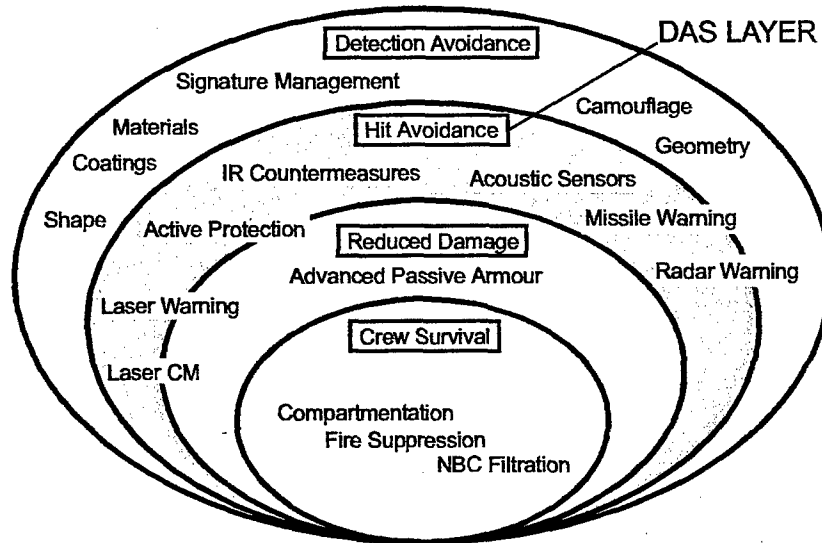

Figure 1. Layers of survivability. With the reduction of passive armour, greater emphasis is placed on detection avoidance and on hit avoidance, the DAS layer.

as propagation of artificial source in the solar-blind ultraviolet regime, natural effects such as solar glint and complicated, variable signatures from missiles are also modelled.

The combination of increasing computer power at low cost and the robustness of ModSAF can also be used to represent vehicles more realistically and in more realistic environments and evaluated more thoroughly than previously possible before final field evaluations. Any weapon system can be improved by better materials and design. ModSAF can be used long before the system is fielded to develop new tactics and doctrine. Crew familiarization and training can be undertaken, initially, on stand-alone systems and progress through to vehicle simulators. In future vehicles, embedded simulators can be used to model the environment surrounding the vehicle, including terrain, atmosphere, threats and other vehicles. Some of the aspects of modelling a counterfire improvement based on a high-speed missile and a typical MBT countermeasure are discussed below.

## 2. SURVIVABILITY

Vehicle survivability can be represented usefully by a series of layers as shown in Figure 1. New vehicles designs place a greater emphasis on the first two layers, detection and hit avoidance, to survive an attack. In the first layer, survivability can be improved by reducing the size and silhouette of the vehicle and through signature management, which is the the reduction to background levels of the radar cross-section and signature in the visible, infrared, electronic, acoustic and magnetic domains.

The next layer, the DAS layer, relies on a system of sensors to collect data, which is then processed to determine the presence of any threats. This system is interfaced to countermeasures through processors, which will determine a prioritized list of responses. As the challenges of hit avoidance, including short timelines and numerous threats, are addressed, the solutions will lead to weapons of greater precision and faster tempo on the battlefield.

Among the many threats to land vehicles, a list of 89 missiles was compiled<sup>3</sup> in Table 1 according to the guidance and communication links used<sup>4</sup>.

In this list, virtually all of the missiles have an operator in the loop leading to the possibility of using a combination of dazzling and obscurants to disrupt the aiming sequence. An effective basic DAS could be based on laser detection, missile-detection tracking and countermeasures including dazzling, obscurants, counterfire and evasive manoeuvres. This "soft-kill" solution can be effective since the large number and variety of threat missiles can make identification, and therefore countermeasure selection, difficult. This difficulty can be overcome with a "hard-kill" solution, which will physically destroy the missile.

Table 1. Threat Missiles Classified by Guidance or Communications System

Number	Missile Type <sup>4</sup>
41	Semi-Automatic Command to Line of Sight (SACLOS)
16	Laser Beam Rider (LBR)
11	Manual Command to Line of Sight (MCLOS)
8	Fibre-optic guided missiles (FOGM)
7	Imaging Infrared
6	Laser and millimetric wave designation, including Semi-Active Homing
3	Laser based guidance or communications link
2	Automatic Command to Line of Sight (ACLOS)
1	Radio Frequency Homing
89/95	Total missiles/Total configurations

### 3. MODELLING AND SIMULATION

A Model-Test-Model cycle is difficult to establish for various reasons including, lack of information about foreign systems and incomplete models of the sensor and countermeasure environment. As shown in Figure 2, a continuous cycle can be established using field trials and experimental data to develop models and simulations. Ideally models should be based on physical principles but when this is impractical, systems can still be analyzed phenomenologically. Both approaches can be implemented in ModSAF. ModSAF (Modular Semi-Automated Forces) was developed for training and doctrine development and provides a capability to define and control entities on a simulated battlefield. It is a model of the dynamic behavior of simulated units, their component vehicles and weapons systems with sufficient realism for training and combat development. ModSAF simulates an extensive list of entities including fixed and rotary wing aircraft, ground vehicles, dismounted infantry, and additional special models such as howitzers, mortars, minefields, and environmental effects. The behaviour of the simulated entities can be scripted so they can move, fire, sense, communicate and react without operator intervention. The entities can interact with each other as well as manned simulators, over a network supported by Distributed Interactive Simulation. Operating over a network is also useful in maintaining a necessary level of security.

These basic feature in ModSAF are sufficient to define the participation of three group of workers and implement their requirements free from mutual interference. To gain general acceptance, ModSAF development must meet the requirements of the scientists and engineers who develop the technology, the operations research community and the military developing tactics and doctrine. MATLAB<sup>®</sup>, which is designed for quick-prototyping and code generation, can be used for ModSAF development. MATLAB<sup>®</sup> modelling can also be used to share information with contractors and other researchers. As shown in Figure 2, an important application of ModSAF is the generation of a battlefield environment for Man-In-the-Loop simulators. The MIL simulators are critical in the development of a suitable Man-Machine-Interface for the DAS.

### 4. DAS DEVELOPMENT FOR LAV

Rapid deployment of the vehicle to a wide range of possible missions and low cost upgrading plays a significant role in the design of the DAS. Some desirable DAS characteristics include a

- fitted for, but not fitted with**, approach providing a quick response at low cost implies designing the vehicles for equipment upgrades according to the mission requirements without needing to purchase for the entire fleet,
- modularity** including minimizing the interference among subsystems, which can complicate an upgrade and incremental upgrades of best of breed technology of a federation of modules instead of an integration of fused sensors,
- mission configurability** relying, for example, on the Galix grenade system that offer a wide range of capability from CS gas and stun grenades for peacekeeping to obscurants and fragmentation grenades for higher intensity warfare and a

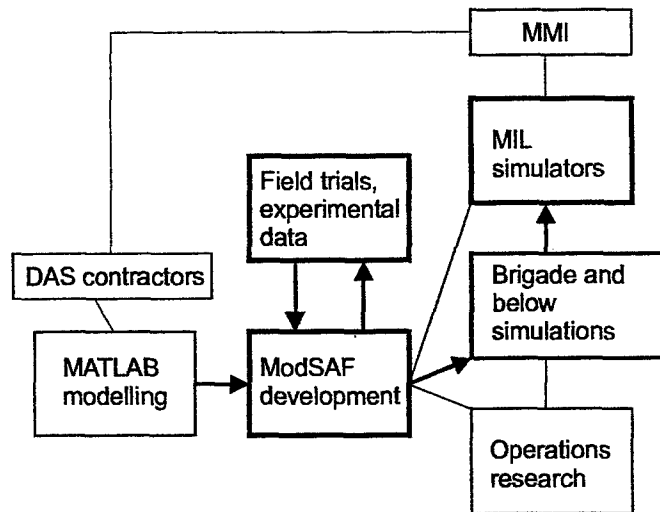

**Figure 2.** The four aspects of ModSAF development are shown. MATLAB<sup>®</sup> is used as a quick-prototyping tool generating, transferrable models and code usable by ModSAF. There is a tight loop between field evaluations and ModSAF development used to design DAS prototypes and plan future trials. Larger battles are carried out in simulation labs where new tactics and doctrine are developed. ModSAF is also used to provide the battlefield around Man-In-the-Loop simulators. From the simulators, the man-machine interface and vehicle operating systems are developed.

**plug and play capability** facilitating fast upgrading and replacement.

This level of readiness also facilitates rapid acquisition of up-to-date technology and further facilitates rapid deployment.

The DAS should be a federated, modular and mission configurable system, interfaced to the vehicle bus for access to other systems such as the Fire Control System. To keep the cost as low as possible the DAS based on more mature technology first and because of the rapidly evolving nature of technology modified through 5-year upgrades. DAS evolution is represented in Figure 3, could be carried out as described in the sections below.

During the 50-year service life of the vehicle, 5-year upgrade cycles will ensure peak performance at a reasonable cost. The basic vehicle configurations described below do not preclude inclusion of other important systems such as sniper or bioaerosol detection and countermeasure. The Defensive Aids Suite is a group of sensors interfaced to countermeasures through data processors generating a list of prioritized responses. The DAS is also connected to the vehicle bus for access to the Fire Control System and the rest of the vehicle for counterfire and countermanoeuvres. The DAS also evolves through regular upgrades as shown in Figure 3. The 2010 and 2015 vehicles would be designed to operate in a network<sup>5</sup>.

**Present day LAV:** The LAV has positive features including an electric turret with a slew rate limited to  $\pm 45^\circ/\text{s}$  with a 25mm Chain Gun<sup>®</sup> with a range of about 2000m. The direct fire capability of the 25mm gun is improved with a laser rangefinder. The LAV has good mobility with a top speed of about 100km/h. The vehicle is however vulnerable to many threats and the ability to detect and counter threats is also limited. The vehicle defensive system includes grenade dispensers and a Laser Warning Receiver with limited one sector resolution. The smoke grenade is a NATO standard grenade with effective obscuration achieved in 2s and persisting for 30s. The metal flake composition produces a spectral coverage from visible to long-wave infrared.

**Laser threat detection:** a laser-warning receiver with an angular resolution of  $\pm 22.5^\circ$

**Countermeasures:** are carried out in sequence shown as required

- obscurants: VIRSS providing spectral coverage from visible to far infrared
- countermanoeuvres and

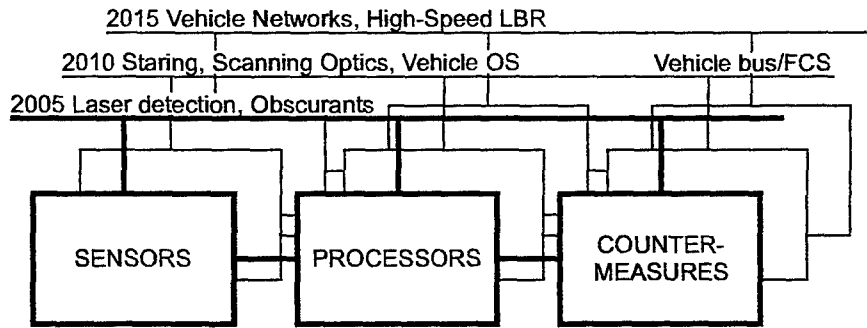

**Figure 3.** The rate at which computer and sensor technologies are developed justifies 5year upgrade increments. The more mature technology is implemented first beginning with laser-aided threat detection and visible/IR/MMW obscurants. Improved situational awareness, detection and identification is possible with staring and scanning optics. An operating system can be interfaced to the vehicle bus and fire control system providing automated response. By 2015, improved survivability can be achieved through vehicle networks and increased operational tempo with a high-speed missile.

- counterfire: based on the 25mm Chain Gun<sup>®</sup> and coaxial 7.62mm machine gun

**2005 Light Armoured Vehicle:** includes automatic, semi-automatic and manual launching of obscurants, manual countermanoeuvres and semi-automatic and manual counterfire. The Defensive Aids Suite will use the more precise HARLID<sup>™</sup> (High Angular Resolution Irradiance Detector) increasing the angular resolution<sup>6</sup> from one sector to  $\pm 1^\circ$ . The P-MILDS will filter out most natural sources of UV and therefore can be used to detect artificial sources<sup>7</sup> including rocket propelled grenades, mortars and machine gun fire. Some missiles can also be detected and tracked where signatures have not been suppressed.

**Laser threat detection:** based on the HARLID<sup>™</sup> and the (BEam Rider Detector) to detect rangefinders, designators, beam riders and weapons over a hemisphere and an angular resolution of  $\pm 1^\circ$  up to a distance of 3km and 7m off-axis

**UV threat detection:** P-MILDS to detect artificial sources including rocket propelled grenades, mortars and machine gun fire over a hemisphere with an angular resolution of  $\pm 2^\circ$

**Missile detection:** based on Radar is used to improve threat detection and tracking

**Countermeasures:** are carried in sequence shown and as required.

- obscurants: VIRSS providing spectral coverage from visible to far infrared
- countermanoeuvres and
- counterfire: based on the 25mm Chain Gun<sup>®</sup> and coaxial 7.62mm machine gun

**2010 Light Armoured Vehicle:** The 2010 DAS is similar to the 2005 system including automatic, semi-automatic and manual response of counterfire, countermanoeuvres and obscurants. The optics used for detection and dazzling are depicted in Figure 4. Infrared Focal Plane Arrays provide a hemispheric coverage for increased situational awareness. A system of organic UAVs is used to improve threat detection with a bird's eye view of the battlefield. Countermeasures are carried in sequence shown below, beginning with dazzling until full obscuration is achieved. Dazzling is intended to interfere with the operator by overloading his optical sight. Radar can be used with the infrared imaging system and smoke grenades to identify and defeat most threats.

High Availability (HA) principles are being used to develop reliable computer systems in critical applications and will probably influence the development of DAS.<sup>5</sup> The high level of reliability and transparency to the user will make the DAS much easier to accept. High Availability technologies available through Jini<sup>™</sup> include Alternate or Redundant Paths to Sensors, Dynamic Reconfiguration of the System comprising dynamic attachment and detachment and "hot pluggable" and "hot swappable" components.

- Real Time Operating System with Java™ capability such as VxWorks®AE by Wind River Systems or LynxOS® by LynuxWorks™
- Computer architecture based on, VMEBus or CompactPCI™

The operating system is critical in the development of High Availability systems. Both VxWorks®AE, and LynxOS® have many of these features. VxWorks®AE is described as a RTOS with HA features including: Reliability, Availability, Serviceability, and Security (RASS).

**Laser threat detection:** based on the HARLID™ and the BERD to detect rangefinders, designators, beam riders and weapons over a hemisphere and an angular resolution of  $\pm 1^\circ$  up to a distance of 3km and 7m off-axis

**UV threat detection:** P-MILDS to detect artificial sources including rocket propelled grenades, mortars and machine gun fire over a hemisphere with an angular resolution of  $\pm 2^\circ$

**IR threat detection:** Infrared Focal Plane Arrays for situational awareness including improved threat detection, 4096x4096 pixels per corner, providing hemispheric coverage, and a scanning NFOV system, typically  $2.5^\circ \times 2.5^\circ$ .

**Visible threat detection:** Laser illuminator and gated camera, typically  $0.5^\circ \times 0.5^\circ$

**Missile detection:** based on Radar is used to improve threat detection and tracking

**Remote sensing:** with a system of organic Unmanned Aerial Vehicles

**Countermeasures:** are carried in sequence shown and as required.

- laser dazzling (requiring a directional platform),
- obscurants: VIRSS providing spectral coverage from visible to far infrared, chaff to extend coverage into the millimetre wave spectrum.
- countermanoeuvres and
- counterfire: based on the 25mm Chain Gun® and coaxial 7.62mm machine gun

**2015 Light Armoured Vehicle:** includes the capability of the previous vehicles. Radar is included for improved threat detection and tracking. The system of organic UAVs is replaced by a larger UAV with improved performance and providing extra information to the platoon of 4 vehicles. The vehicle network shares threat and countermeasure information with nearby platforms as shown in Figure 5.

Future vehicles can be configured into networks with an emphasis on the following networking technologies: <sup>5</sup>

- ISTAR network, to integrate all battlefield assets for command and control
- Jini™ layer/Rio™ facilitates a seamless and transparent integration of vehicles and platforms based on availability, threat location and weapon capability.

The 25mm gun can be either replaced or augmented by a high-speed beam riding missile to increase the range to 5km with extra targeting information supplied by the UAV. Active armour is used to counter kinetic energy threats more effectively. The Radar system mentioned above is an essential component of the active armour system but may also be used directly to launch smoke grenades as required.

**Laser threat detection:** based on the HARLID™ and the BERD to detect rangefinders, designators, beam riders and weapons over a hemisphere and an angular resolution of  $\pm 1^\circ$  up to a distance of 3km and 7m off-axis

**UV threat detection:** P-MILDS to detect artificial sources including rocket propelled grenades, mortars and machine gun fire over a hemisphere with an angular resolution of  $\pm 2^\circ$

**IR threat detection:** Infrared Focal Plane Arrays for situational awareness including improved threat detection, 4096x4096 pixels per corner, providing hemispheric coverage, and a scanning NFOV system, typically  $2.5^\circ \times 2.5^\circ$ .

**Visible threat detection:** Laser illuminator and gated camera, typically  $0.5^\circ \times 0.5^\circ$

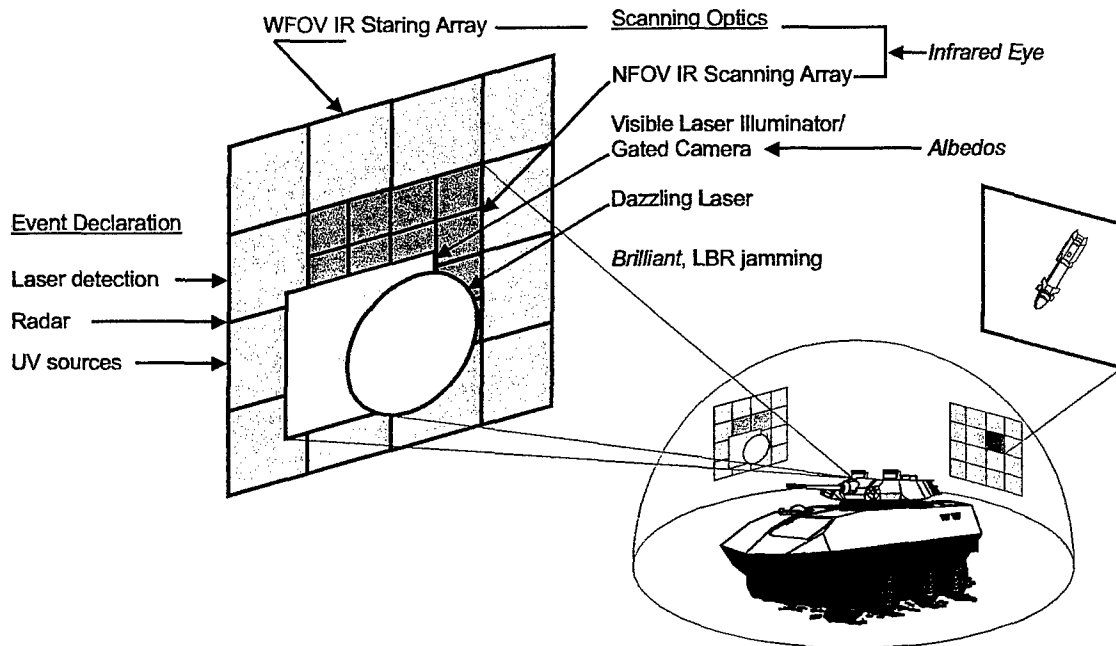

**Figure 4.** Most threats detected by the staring array (*far right*) will be subpixel in size. Detection can be improved by scanning with a higher resolution array (*center*). A visible laser illuminator and a gated camera improves detection during nighttime and low-light conditions. The visible and infrared imagery can be combined to provide a composite display for the crew. Dazzling disrupts aiming and guidance while the main turret slew to position. Prototypes of these systems include: *Infrared Eye*, *ALBEDOS* and *Brilliant*, which is a laser beamrider countermeasure. Radar, UV imagers and laser detectors (*far left*) are used with these optical systems to identify potential threats. ModSAF will be used to analyze the timelines for detection, tracking and identification.

**Missile detection:** based on Radar is used to improve threat detection and tracking

**Remote sensing:** with a UAV assigned to the platoon of four vehicles depicted in Figure 5.

**Countermeasures:** are carried in sequence shown and as required.

- laser dazzling (requiring a directional platform),
- obscurants: VIRSS providing spectral coverage from visible to far infrared, chaff to extend coverage into the millimetre wave spectrum.
- countermanoeuvres,
- counterfire based on
  - high-speed beam-riding missile,
  - 120mm low pressure gun,
  - 25mm Chain Gun<sup>®</sup> and coaxial 7.62mm machine gun
- active armour relying on the targeting information of the IRFPA and Radar.

## 5. MISSILE EVALUATION ENVIRONMENT

The direct fire capability of the LAV can be improved while maintaining a high operational tempo by developing a high-speed beam-riding missile. The missile is designed to accelerate a high density projectile, 0.5m long, to a velocity exceeding 2000m/s. The velocity is chosen to defeat soft-kill countermeasures by reducing the response time as much as possible and maintaining sufficient kinetic energy to penetrate MBT armour at the range limit of the main weapon. A typical engagement is shown in Figure 6. This missile is expected to be available for the 2015 vehicle described previously. A



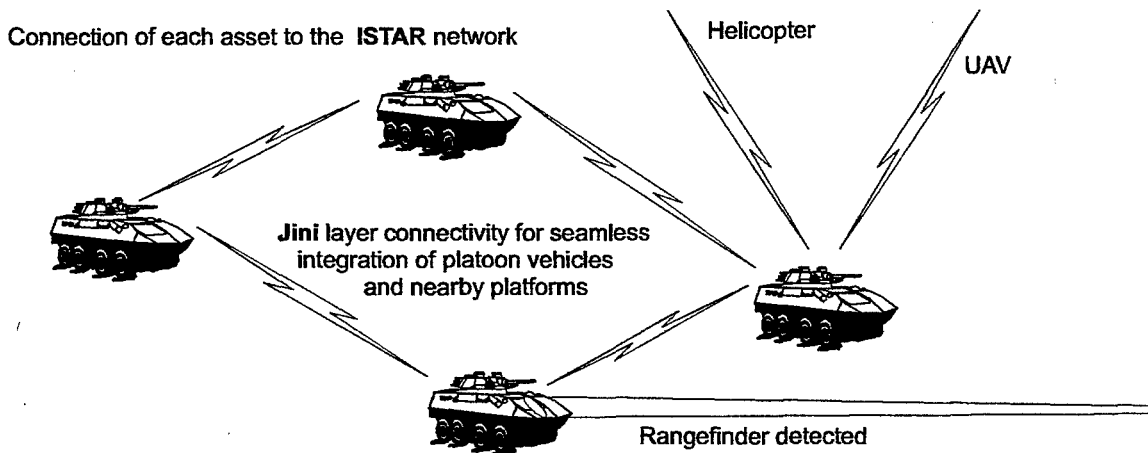

SINGLE LAV	VEHICLE NETWORK
HARLID DETECTS RANGEFINDER AT 1.8km	HARLID DETECTS RANGEFINDER AT 1.8km
COMMANDER CHOOSES FROM APFSDS 150 ROUNDS HEI 60 ROUNDS	UAV CORRECTS RANGE TO 1.853km COMMANDER CHOOSES FROM APFSDS 600 ROUNDS ROCKETS 38 HEI 240 ROUNDS
APFSDS CHOSEN AND FIRED	APFSDS CHOSEN AND FIRED

Figure 5. The UAV provides improved targeting information to the LAV Fire Control System. When a rangefinder pulse is detected. The commander in the single LAV, left, has to look down the direction indicated by the HARLID™ to locate the threat. The HARLID™ in a vehicle network, right, detects the threat and shares this information with other platforms in the network. The UAV uses this approximate location to find threat and transmit a better estimate. The commander sees all the weapons available on the network including rockets from a helicopter hovering nearby. The APFSDS is selected and fired from any valid network gun. In the meantime, the commander protects the vehicle by dazzling, launching grenades and countermanoeuvring.

realistic evaluation would require that both the LAV and MBT be equipped with technology available for that time period. The MBT defence is based on the hardkill system, AWiSS-K, designed by DIEHL Munitionssysteme to stop kinetic energy penetrators.

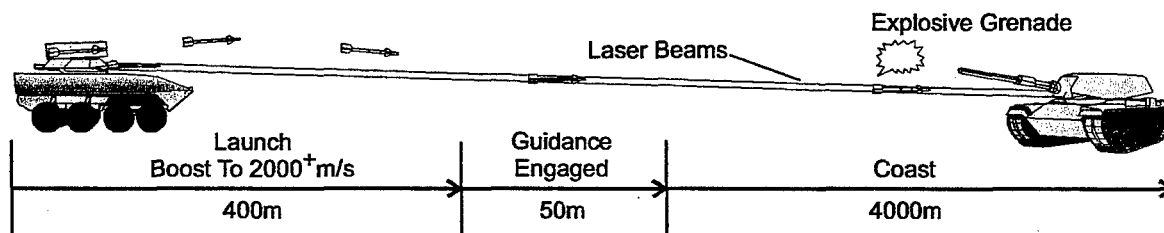

Figure 6. To keep the laser-based guidance path clear of propellant smoke, the missile is launched away from the beams until burn out occurs. The missile is then gathered in and guided to the target. The MBT (right) launches an explosive charge to deflect or destroy the missile.

### 5.1. Variables affecting missile lethality

The MBT and active protection will be modelled as follows:

**Threat Detection and Tracking:** The best performance is expected from a combination of radar for velocity data and a high resolution staring array for more precise angular position.

**Radar:** limited to a range of 500m to avoid detection. The initial missile velocity and direction are measured to within  $\pm 22\text{m/s}$  and  $\pm 1\text{millirad}$ , respectively.

**IR imagery:** based on a system of infrared focal plane arrays with hemispheric coverage with effectively  $4096 \times 4096$  pixels per corner. Detection algorithms will be used to alert the crew or automated system of MBT-like objects within range. It will be possible to detect and observe the orientation of the missile launchers and provide an early warning of a possible threat.

**Countermeasure before missile launch:** By detecting the turret-mounted launchers the MBT can react before the missile is launched.

**Dazzling:** Before effective obscuration occurs, which is about 2s for a NATO standard grenade, dazzling can be used to disrupt aiming.

**Obscuration:** Obscuration grenades based on a metal flake design can be used from visible through long wave infrared.

Radar and IR imagery provide an estimate of the missile position which is then used to aim the explosive charge. The AWiSS-K grenade is designed to explode at a fixed distance of 50m from the MBT launcher. It is possible to compensate for any systematic lag but there are still random variables that can affect the position and detonation of the explosive charge.

**Countermeasure of launched missile:** The DIEHL Munitionssysteme AWiSS-K is designed to deflect or destroy the missile. The explosive charge has a propagation velocity estimated at  $2000\text{m/s}$ , but several variables can effect the positioning of the blast wave.

**Grenade:** variation in time to achieve maximum thrust,  $< 10\text{ms}$ .

**Explosive charge:** variation in ignition lag time,  $< 10\text{ms}$ .

## 6. CONCLUDING REMARKS

A procedure has been outlined to improve the development of DAS technology by combining prototype development and field trials with modelling and simulation based on operations research codes and off-the-shelf software tools. This new capability will provide a better estimate of vehicle performance on the battlefield and lower the cost of DAS development by complementing existing MIL facilities.

## REFERENCES

1. J.L. Rapanotti, A. DeMontigny, M. Palmarini and A. Cantin, "Assessing the effectiveness of defensive aids suite technology", SPIE AeroSense Conference, April 2001.
2. J.L. Rapanotti, A. DeMontigny, M. Palmarini and A. Cantin, "Developing Vehicle Survivability on a Virtual Battlefield", NATO Modelling and Simulation Group Symposium, November 2001.
3. J.L. Rapanotti, A. Cantin, and R.G. Dickinson, "Preliminary Study of Defensive Aids Suite Technology", DREV Technical Report (to be published).
4. R.G. Lee, T.K. Garland-Collins, D.E. Johnson, E. Archer, C. Sparkes, G.M. Moss and A.W. Mowat, "Guided Weapons", Bassey's (UK) Ltd., Third Edition 1998.
5. J.L. Rapanotti, M. Palmarini and M. Dumont, "New computer and communications environments for light armoured vehicles", SPIE AeroSense Conference, April 2002.
6. P. Webb, S. Soltesz, A. Cantin, J. Fortin and D. Pomerleau, "Improved miniaturized HARLID<sup>TM</sup> for laser warning systems having high angular resolution", SPIE AeroSense Conference, April 2001.
7. J.L. Rapanotti, "IR sensor design insight from missile plume prediction models", SPIE AeroSense Conference, April 2002.