

UNCLASSIFIED

Defense Technical Information Center  
Compilation Part Notice

ADP019439

TITLE: Simulation of the Vacuum Assisted Resin Transfer Molding Process

DISTRIBUTION: Approved for public release, distribution unlimited

This paper is part of the following report:

TITLE: International Conference on Flow Processes in Composite Materials Held in Newark, Delaware on 7-9 July, 2004

To order the complete compilation report, use: ADA433173

The component part is provided here to allow users access to individually authored sections of proceedings, annals, symposia, etc. However, the component should be considered within the context of the overall compilation report and not as a stand-alone technical report.

The following component part numbers comprise the compilation report:

ADP019391 thru ADP019474

UNCLASSIFIED

# Simulation of the Vacuum Assisted Resin Transfer Molding Process

Xiaolan Song<sup>1</sup>, Alfred C. Loos<sup>2</sup>, Brian Grimsley<sup>3</sup>, Roberto Cano<sup>3</sup> and Pascal Hubert<sup>4</sup>

<sup>1</sup> *Materials Technology Center*

*Southern Illinois University, Carbondale, IL 62901:xiaolan@siu.edu*

<sup>2</sup> *Department of Mechanical Engineering*

*Michigan State University, East Lansing, MI 48824*

*And Corresponding Author's email: aloos@egr.msu.edu*

<sup>3</sup> *NASA Langley Research Center, Hampton, VA 23681,*

*b.w.grimsley@larc.nasa.gov, r.j.cano@larc.nasa.gov*

<sup>4</sup> *Department of Mechanical Engineering, McGill University*

*Montreal, Quebec H3A2K6, CANADA:pascal.hubert@mcgill.ca*

**SUMMARY:** A process model that includes the coupled phenomenon of resin flow and preform compaction was developed and used to simulate resin infiltration of a fibrous preform using the vacuum assisted resin transfer molding (VARTM) process. Flow of resin through the distribution medium and preform were modeled as flow through porous media. The finite element/control volume method was used to calculate the infiltrating fluid pressure distribution and track the progression of the flow front. The simulation results were compared with data obtained during infiltration of a carbon fiber preform with an epoxy resin. The parameters measured include the flow front location, resin pressure and preform thickness change. With accurate inputs, the flow front locations and resin pressure distribution can be accurately predicted. The predicted transverse displacements do not agree well with the experimental measurements. The reasons for the differences are discussed, and further investigations are recommended to develop a more accurate compaction model.

**KEYWORDS:** VARTM, Flow Modeling, Composite Materials, Composite Manufacturing

## INTRODUCTION

Vacuum Assisted Resin Transfer Molding (VARTM) is a variant of the traditional RTM process in which one of the solid tool faces is replaced by a flexible vacuum bag. VARTM offers numerous cost advantages over traditional RTM, such as lower tooling cost and shorter start-up time. However, it has been well documented that resin infiltration of a fibrous preform is a complex process and often dry or unimpregnated areas can occur in the preform. In addition, the flexible nature of the vacuum bag makes it difficult to control the cured thickness and fiber volume fraction of the composite. Due to the complex nature of the VARTM process, trial and error methods of process development are inefficient and expensive. The objective of this study was to develop and verify a comprehensive VARTM simulation model as a cost effective design tool.

## MODEL DEVELOPMENT

The VARTM process consists of two important mechanisms, the flow of the resin through the preform and compaction and relaxation of the preform during infiltration. Hence, the simulation model of the VARTM fabrication procedure consists of a flow submodel and a compaction submodel.

### Flow Model

The flow model was developed to track the flow of the resin through the distribution medium and the preform. Both the high-permeable distribution medium and the preform can be modeled as heterogeneous and anisotropic porous media. The resin fluid is assumed to be Newtonian and incompressible. Assuming that the flow is quasi-steady state, the governing equations for the flow problem are the continuity equation for an incompressible fluid, and Darcy's law of flow through a porous medium:

$$\nabla \cdot \bar{v} = 0 \quad (1)$$

$$\bar{v} = \frac{\bar{q}}{\phi} = -\frac{S}{\phi\mu} \nabla P_r \quad (2)$$

where,  $\bar{v}$  is the interstitial velocity vector,  $\bar{q}$  the superficial velocity vector,  $\phi$  the porosity of the preform,  $\mu$  the viscosity of the resin,  $S$  the permeability tensor of the preform, and  $P_r$  is the resin pressure.

Note that this is a moving boundary problem. The finite element/control volume (FE/CV) method [1] is utilized to track the progression of the flow front. At each time step, the Galerkin finite element method is used to solve for the pressure distribution in the fluid. The resin velocities are then calculated using Eqn. (2). With resin velocities obtained, the flow front location at that time is determined by means of the control volume technique.

### Compaction Model

Due to the flexible nature of the vacuum bag, there is no direct control over the thickness or fiber volume fraction of the composite part. The compaction of the reinforcement preform is complex and depends on the compressibility and relaxation of the reinforcement under pressure, and the interaction between the reinforcement and the resin flow.

It is well accepted that during the flow of the resin in the fiber preform, the total compaction pressure is shared by the resin pressure and the pressure supported by the fiber network.

Therefore, Eqn. (3) is introduced to account for the transverse equilibrium inside the mold cavity during impregnation [2]:

$$P_c = P_r + P_n \quad (3)$$

where,  $P_c$  is the total compaction pressure,  $P_r$  is the resin pressure, and  $P_n$  is the effective compressive stress in the preform, often referred to as the net pressure applied to the preform.

For the VARTM process, the external pressure applied is the atmospheric pressure. At each time step, once the resin pressure distribution is obtained from the resin flow model, the pressure supported by the preform is computed using Eqn. 3. The normal strain in the preform along the transverse direction ( $\epsilon$ ) is a function of the net pressure applied to the preform.

The relationship between the compressive strain in the preform and the applied pressure is obtained by fitting the compaction test results to an empirical model. Two important phenomena are observed during the compaction experiments. First, because of the resin lubrication effect, the fiber sample saturated with resin is compacted more than the dry reinforcement under the same pressure. Second, the compressive response of the preform is not elastic and hysteresis occurs during the unloading process [3].

During the VARTM infusion process, before the resin front approaches, the dry reinforcement is under vacuum compression. Thus, the compressive strain of the preform can be calculated from the compaction response of the dry preform during the loading process. After the resin passes, the local net pressure applied to the preform decreases as a result of the increasing resin pressure. This is equivalent to an unloading process. Accordingly, the strain in the wet preform is determined by the compaction response of the resin saturated preform during the unloading process.

### MODEL SIMULATIONS

The process simulation model was used to investigate resin infiltration of a 60.96 cm by 30.48 cm preform by the VARTM process. For the simulations, the properties of SAERTEX<sup>®</sup> multi-axial warp-knit (MAWK) carbon fiber fabric were used for the preform and A.T.A.R.D. Laboratories SI-ZG-5A epoxy were used for the resin. To assess the accuracy of the model, the flow patterns and the changes in resin pressure and preform thickness were measured during infiltration of the carbon preform. Fig. 1 shows the dimensions of the preform and the locations of the pressure sensors and Linear Variable Displacement Transducers (LVDT). Details of the instrumentation and the experimental procedures can be found in reference 4.

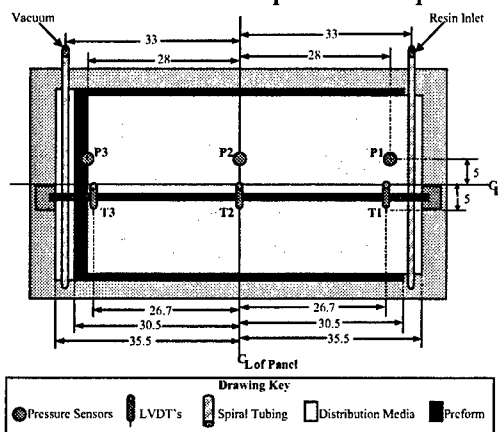

Fig. 1 Instrumented VARTM tool

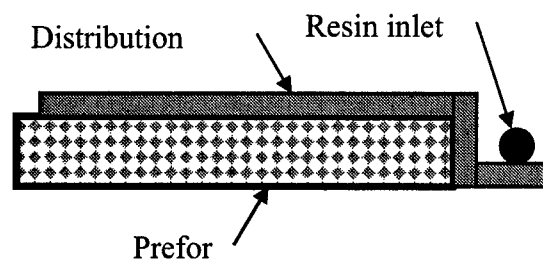
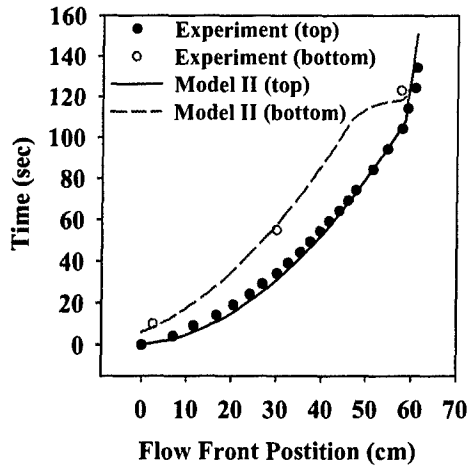

Fig. 2 Cross-section of preform and distribution medium

For the flat panels investigated in this study, resin flow is uniform across the width of the panels, except at the edges where there is no distribution medium. Hence, the resin velocity in the width direction is negligible and the resin infiltration of the flat preform can be modeled as a two-dimensional flow problem. Figure 2 shows the two-dimensional model of the preform and distribution medium. Linear two-dimensional quadrilateral elements were used to create the finite element mesh.

Shown in Fig. 3 is infiltration time versus flow front position at the top and bottom surfaces of the preform. The flow front at the top surface of the preform was recorded using a digital video camcorder. The bottom flow front position was obtained from the tool mounted pressure sensor responses recorded during the test. Overall, the agreement between the predicted and measured flow front position was very good.



Infiltration time versus position

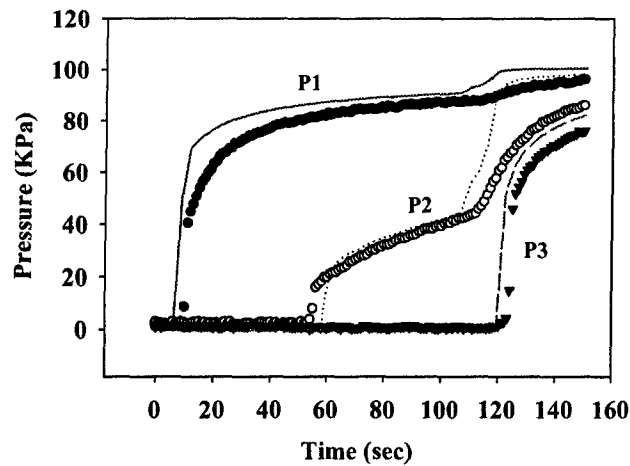

Fig. 3  
Fig. 4 Pressure versus infiltration time

Resin pressure as a function of infiltration time is reported in Fig. 4. The solid lines represent the model predicted pressures, while the symbols represent the pressures measured by the three transducers mounted in the tool (Fig. 1). Agreement between the calculated and measured pressures at the three sensor locations was very good.

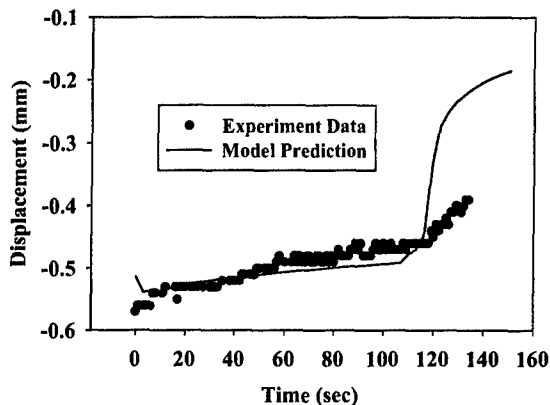

Fig.5 Displacement versus time at T1

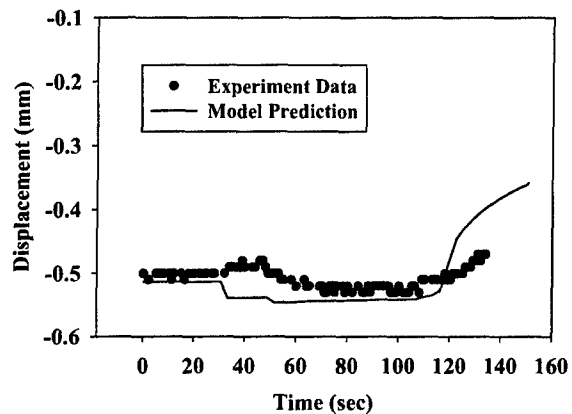

Fig. 6 Displacement versus time at T2

The measured and calculated displacements are compared in Figs. 5 and 6. Qualitatively, the calculated thickness changes of the preform agree well with the experimental measurements. Before the resin inlet opens, the dry preform is compacted under vacuum and initial displacements are induced. After the infusion process begins, the presence of the resin affects the compaction of the preform by two different mechanisms [3]. First, the lubrication effect of the resin causes rearrangement of the fiber network and an increase in the preform compaction.

This mechanism is called the wetting compaction effect of the resin. On the other hand, the increase of the resin pressure leads to a decrease of the pressure applied to the preform. Consequently, the amount of the preform compaction decreases. This is called the springback mechanism. During the infiltration process, the net compaction of the preform depends on the relative magnitude of the wetting and springback deformation mechanisms. Therefore, both the simulation and the experiment find that the compaction responses of the preform at the three LVDT positions are different. T1 moderately decreased after the resin passed by, while T2 increased after the flow front approached. After the flow front reached the end of the distribution medium, T1, T2, and T3 all decreased rapidly due to the sharp increase in the resin pressure. The sudden increase in preform thickness was observed at 115 seconds in the experiment, and the phenomenon was predicted to occur at 116 seconds in the simulation. Both the simulation and the experiment find that at the end of the infiltration process,  $T1 < T2 < T3$ . This indicates that the panel is less compacted on the resin inlet side and more compacted on the vacuum side.

## CONCLUSIONS

In this investigation, a comprehensive Vacuum Assisted Resin Transfer Molding (VARTM) process simulation model was developed and verified. The model incorporates resin flow through the perform and compaction and relaxation of the perform. The computer model can analyze the resin flow details, track the thickness change of the preform, predict the total infiltration time and final fiber volume fraction of the parts, and determine whether the resin could completely infiltrate and uniformly wet out the preform.

## ACKNOWLEDGEMENTS

The work was supported by NASA Langley Research Center under Research Cooperative Agreement NCC-1-01037. The project monitor is Mr. Roberto J. Cano.

## REFERENCES

1. H. P. Wang and H. S. Lee, Fundamental of Computer Modeling for Polymer Processing, Chapter 8, ed. C. L. Tucker, Hanser Publishers (1989).
2. A. Hammami and B. R. Gebart, "Analysis of the Vacuum Infusion Molding Process," *Polymer Composites*, Vol. 21, no. 1, pp. 28-40 (2000).
3. B. W. Grimsley, P. Hubert, X. Song, R. J. Cano, A. C. Loos, and R. B. Pipes, "Flow and Compaction during the Vacuum Assisted Resin Transfer Molding Process," *SAMPE Technical Conference*, Vol. 33, pp. 140 – 153 (2001).
4. X. Song, "Vacuum Assisted Resin Transfer Molding (VARTM): Model Development and Verification," Ph.D. Dissertation, Virginia Polytechnic Institute and State University, Blacksburg, VA, April 2003.