

UNCLASSIFIED

Defense Technical Information Center
Compilation Part Notice

ADP013503

TITLE: Minimizing Load Effects on NA4 Gear Vibration Diagnostic
Parameter

DISTRIBUTION: Approved for public release, distribution unlimited

This paper is part of the following report:

TITLE: New Frontiers in Integrated Diagnostics and Prognostics.
Proceedings of the 55th Meeting of the Society for Machinery Failure
Prevention Technology. Virginia Beach, Virginia, April 2 - 5, 2001

To order the complete compilation report, use: ADA412395

The component part is provided here to allow users access to individually authored sections
of proceedings, annals, symposia, etc. However, the component should be considered within
the context of the overall compilation report and not as a stand-alone technical report.

The following component part numbers comprise the compilation report:

ADP013477 thru ADP013516

UNCLASSIFIED

MINIMIZING LOAD EFFECTS ON NA4 GEAR VIBRATION DIAGNOSTIC PARAMETER

Paula J. Dempsey and James J. Zakrajsek
National Aeronautic and Space Administration
Glenn Research Center
Cleveland, Ohio 44135

Abstract: NA4 is a vibration diagnostic parameter, developed by researchers at NASA Glenn Research Center, for health monitoring of gears in helicopter transmissions. NA4 reacts to the onset of gear pitting damage and continues to react to the damage as it spreads. This research also indicates NA4 reacts similarly to load variations. The sensitivity of NA4 to load changes will substantially affect its performance on a helicopter gearbox that experiences continuously changing load throughout its flight regimes. The parameter NA4 has been used to monitor gear fatigue tests at constant load. At constant load, NA4 effectively detects the onset of pitting damage and tracks damage severity. Previous research also shows that NA4 reacts to changes in load applied to the gears in the same way it reacts to the onset of pitting damage. The method used to calculate NA4 was modified to minimize these load effects. The modified NA4 parameter was applied to four sets of experimental data. Results indicate the modified NA4 is no longer sensitive to load changes, but remains sensitive to pitting damage.

Key Words: Damage assessment; Damage detection; Gears; Health monitoring; Oil debris monitor; Pitting fatigue; Transmissions; Vibration

Introduction: Although various techniques exist for diagnosing damage in helicopter transmissions, the method most widely used involves monitoring vibration. Numerous algorithms have been developed for the processing of vibration data collected from gearbox accelerometers to detect when gear damage has occurred. One of these algorithms, NA4, was developed to detect the onset of gear damage and to continue to react to the damage as it spreads [1]. NA4 is a dimensionless parameter with a nominal magnitude of approximately 3. When pitting damage occurs, the magnitude of NA4 shows a significant increase above 3. Unfortunately, NA4 responds similarly to load changes. The sensitivity of NA4 to even minor changes in load has been documented in several research papers [2,3]. The magnitude of NA4 reacts to changes in load since the load change affects the running average in the denominator of this algorithm. When using this algorithm to detect gear pitting damage on helicopter gearboxes in different flight regimes, the load effect on this algorithm must be minimized. The goal of this research was to minimize the effect of load on vibration diagnostic parameter NA4 while maintaining its sensitivity to pitting damage.

Apparatus and Test Procedure: Experimental data was recorded from tests performed in the Spur Gear Fatigue Test Rig at NASA Glenn Research Center [4]. Figure 1 shows the test

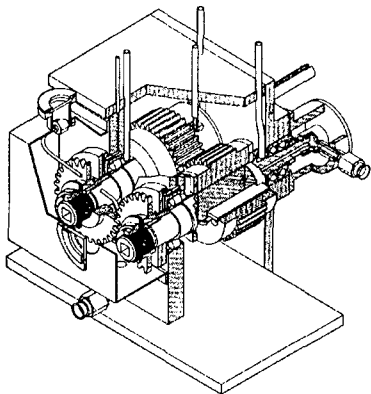

Figure 1.—Spur gear fatigue test rig.

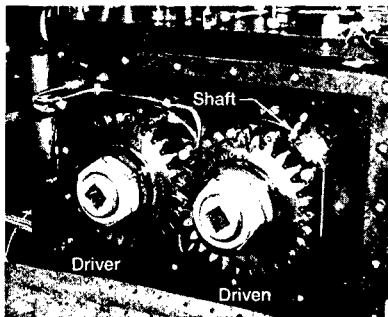

Figure 2.—Accelerometer location on spur gear fatigue test rig.

a commercially available oil debris sensor that measures the change in a magnetic field caused by passage of a metal particle. The amplitude of the sensor output signal is proportional to the particle mass. The sensor measures the number of particles, determines their approximate size (125 to 1000 microns), and calculates an accumulated mass [8]. The ODM was used to automatically shut down the rig when the accumulated mass measured by the monitor exceeded a preset limit.

Speed, pressure, ODM, and raw vibration data were collected and processed in real time using the program ALBERT, Ames-Lewis Basic Experimentation in Real Time, codeveloped by NASA Glenn and NASA Ames. Pressure data was recorded once per minute. Vibration and speed data was sampled at 200 kHz for a 1-sec duration every minute. Vibration algorithm NA4 was calculated from this data and recorded every minute. Vibration algorithm FM4 was also calculated from this data. FM4 is a widely recognized vibration algorithm developed to detect changes to the vibration pattern resulting from damage to a limited number of teeth. FM4 is a nondimensional number independent of load and speed [7, 9, 10].

apparatus. Operating on a four-square principle, the shafts are coupled together with torque applied by a hydraulic loading mechanism that twists two shafts with respect to one another. The power required to drive the system is that to overcome friction losses in the system [5]. The test gears are standard spur gears having 28 teeth, a 3.50-in.-pitch diameter, and a 0.25-in.-face width.

Data was collected using vibration, speed, and pressure sensors installed on the test rig. Vibration was measured on the housing near a shaft support bearing using a miniature, lightweight, piezoelectric accelerometer. The location of this sensor is shown in Fig. 2. This location was chosen based on an analysis of optimum accelerometer location for this test rig [6]. Gear rotation and speed was measured by an optical sensor that creates a pulse signal for each revolution of the gear. Hydraulic pressure to the loading device was measured using a capacitance pressure transducer. Shaft torque is proportional to the pressure. The measured pressure will be referred to as load pressure in this report.

Data was also collected from an oil debris monitor (ODM). The ODM is installed on the rig to give another indication when pitting damage occurs [7]. Oil debris data was collected using

Gears are run until initial pitting occurs on two or more teeth. Pitting is a fatigue failure of the gear material on or near the surface induced by repeated contacts. Pitting is documented by a video inspection system installed on the rig capable of following the progression of gear pitting while avoiding the need to remove the gearbox cover. The gears were inspected periodically based on a limit set on the ODM. For the purpose of this paper, different levels of pitting must be defined. Due to the limited resolution of the video camera, only wear and two levels of pitting could be monitored; initial and destructive. Initial pitting could not be verified until inspection at completion of the experiment. For the purpose of identifying the damaged gear, the gears are referred to as "driver" and "driven" as shown in Fig. 2.

Vibration Diagnostic Parameter NA4: The method used to calculate NA4 is published in several research papers and will be discussed in the following paragraphs [2,11]. The first step in calculating NA4 is to calculate the time-synchronous average of the raw vibration data. Signal time-synchronous averaging is used to extract waveforms synchronous with gear rotation from the total vibration signal. Vibration data is sampled at 200 kHz for a 1-sec duration and is then averaged synchronous to gear rotation. The desired signal which is synchronous with the gear rotation will intensify relative to the nonsynchronous signals. This time synchronous average signal is used to calculate NA4.

Several statistical and filtering operations are used to calculate NA4. First, the regular gear-meshing components are filtered from the signal resulting in a residual signal. The regular gear-meshing components are the shaft and gear-meshing frequencies and their harmonics. Variance and kurtosis are then calculated from the residual signal. The numerator, kurtosis, the fourth moment of a probability density function, is used to indicate when the distribution is more peaked than a normal distribution.

The denominator is the square of the average variance, the mean value of the variance of all previous readings in the run ensemble [11]. The NA4 is calculated as follows:

$$NA4(M) = \frac{N \sum_{i=1}^N (r_i - \bar{r})^4}{\left\{ \frac{1}{M} \sum_{j=1}^M \left[\sum_{i=1}^N (r_{ij} - \bar{r}_j)^2 \right] \right\}^2} \quad (1)$$

where

r = residual signal = shaft and meshing frequencies and their harmonics removed from Fast Fourier Transform (FFT) of time-synchronous-averaged signal

\bar{r} = mean value of residual signal

N = total number of interpolated data points per reading

i = interpolated data point number per reading

M = current reading number

j = reading number

A change to the calculation of NA4 is required to minimize the effect of a fluctuating load on NA4. This change, NA4 reset, is made when the load increases or decreases by a given

percentage. For this application, a 10 percent load change was used. For NA4 reset, when the load changes by 10 percent, the denominator resets to the square of the variance of the same reading, and a new average variance is calculated starting with the reading measured when the load changed. Each time the load changes by 10 percent, the first reading in the average variance resets to the first reading when the load changed. This first reading is calculated as follows:

$$NA4(M) = \frac{N \sum_{i=1}^N (r_i - \bar{r})^4}{\left[\sum_{i=1}^N (r_i - \bar{r})^2 \right]^2} \quad (2)$$

where

r = residual signal = shaft and meshing frequencies and their harmonics removed from FFT of time-synchronous-averaged signal

\bar{r} = mean value of residual signal

N = total number of interpolated data points per reading

i = interpolated data point number per reading

This denominator for the readings that follow is calculated as the square of the average variance, the mean value of the variance of all previous readings starting with the first reading when the load changed. Each time the load changes ± 10 percent, the denominator is reset by using Eq. (2) for the initial reading.

In addition to load changes, NA4 was also sensitive to restarts after the test rig was shut down. The shutdowns are logged automatically in the data acquisition system during each experiment. This information was used to calculate NA4 reset when the rig was restarted after a shutdown.

Discussion of Results: The analysis discussed in this section is based on data collected during four experiments, three of which pitting damage occurred. The first experiment was to verify the effect of load on the NA4 parameter. The load was increased and decreased with NA4 calculated from the vibration data. The gear set had no evidence of pitting before or after the test. A plot of load pressure, NA4, and NA4 reset for the first experiment is shown in Fig. 3. Data was collected every minute; therefore, the reading number is equivalent to minutes. Since the shaft speed is 10 000 revolutions per minute, the reading number can also be interpreted as mesh cycles equal to the reading number times 10^4 .

As discussed previously, NA4 reset is the same as NA4 except the average variance in the denominator is reset each time the load fluctuated by 10 percent. From this plot, the sensitivity of NA4 to changes in load can be easily observed. NA4 appeared to track load pressure. The plot of NA4 reset shows that applying this technique minimizes the sensitivity of NA4 to load.

Although the sensitivity of NA4 to load changes can be corrected by resetting the denominator, one must verify that applying this technique does not significantly decrease the

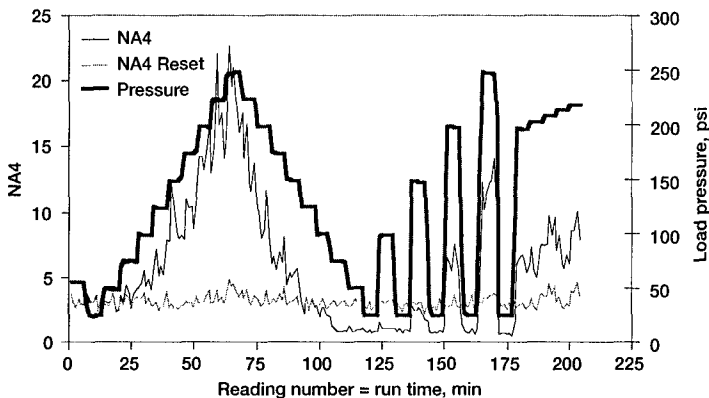

Figure 3.—Data from experiment 1 illustrating load effects.

TABLE I.—DAMAGE DESCRIPTION FOR EXPERIMENT 2

Reading number run time (min)	Damage description	Teeth damaged on driver gear	Teeth damaged on driven gear
60	Run-in wear	All	All
120	Run-in wear	All	All
1581	Run-in wear	All	All
10622	Run-in wear	All	All
14369	Wear	All	All
	Destructive pitting	6	6
14430	Wear	All	All
	Destructive pitting	6	6
14512	Wear	All	All
	Destructive pitting	6, 7	6, 7
14688	Wear	All	All
	Destructive pitting	6, 7	6, 7
14846	Wear	All	All
	Destructive pitting	6, 7	6, 7
15136	Wear	All teeth	All teeth
	Initial pitting	All teeth	
	Destructive pitting	6, 7, 8	6, 7, 8

sensitivity of NA4 to pitting damage. Data from three experiments when pitting damage occurred and the load fluctuated was used to verify resetting the denominator of NA4 did not decrease its sensitivity to pitting damage. Descriptions of the pitting damage that occurred during these three experiments are listed in Tables I to III. Photos of damage progression on a selected tooth during each experiment are shown in Figs. 4 to 6. The test gears are run offset to provide a narrow effective face width to maximize gear contact stress. Damage levels are described as follows:

- (1) Wear—Layers of metal uniformly removed from the surface
- (2) Initial Pitting—Pits of the initial type are less than 1/64 in. in diameter and cover less than 25 percent of the tooth contact area
- (3) Destructive Pitting—Destructive pitting is more severe with pits greater than 1/64 in. in diameter and cover greater than 25 percent of the tooth contact area

TABLE II.—DAMAGE DESCRIPTION FOR EXPERIMENT 3

Reading number run time (min)	Damage description	Teeth damaged on driver gear	Teeth damaged on driven gear
0			
1573	Run-in wear	All	All
2199	Wear Destructive pitting	All	All 11
2296	Wear Destructive pitting	All	All 10, 11
2444	Wear Initial pitting Destructive pitting	All All 10, 11	All 10, 11, 14 10, 11, 14

TABLE III.—DAMAGE DESCRIPTION FOR EXPERIMENT 4

Reading number run time (min)	Damage description	Teeth damaged on driver gear	Teeth damaged on driven gear
0			
58	Run-in wear	All	All
2669	Wear Destructive pitting	All 1, 28	All 1, 28
2857	Wear Destructive pitting	All 1, 6, 28	All 1, 6, 28
3029	Wear Initial pitting Destructive pitting	All All 1, 6, 28	All 1, 6, 28 1, 6, 28

Initial pitting on specific teeth will only be discussed in reference to test completion. Although initial pitting most likely occurred prior to test completion, a detailed analysis of the inspection images is required to verify when it occurred and is outside the scope of this paper.

Plots of the data measured during these three experiments are shown in Figs. 7 to 13. Two different plots are shown for each experiment. The first plot is of load pressure, NA4, and NA4 reset for each experiment. The diamonds indicate when the rig was restarted after a shutdown. The second is a plot of FM4, NA4 reset, and the accumulated mass from the ODM. The triangles on the x-axis indicate the reading number that the rig was shut down for inspection. These reading numbers are listed in Tables I to III. Each experiment will be discussed in turn.

Experiment 2 is plotted in Figs. 7 to 9. Figure 7 shows the effect of the rig restarts after shutdowns on NA4 by the NA4 magnitude spikes that occur after shutdowns. Figures 8 and 9 indicate damage occurred just prior to inspection at reading 14369. Inspection at reading 14369 indicated destructive pitting first occurred on driver and driven tooth 6. The progression of damage is detailed in Table I and Fig. 4. Both NA4 and FM4 indicate an increase in magnitude when it appears destructive pitting occurred. The NA4 reset, like FM4, is less sensitive to damage as it progresses to a number of teeth and becomes more severe.



Figure 4.—Damage progression of driver/driven tooth 6 for experiment 2.

Experiment 3 is plotted in Figs. 10 to 11. Damage progression is shown in Table II and Fig. 5. Destructive pitting occurred on driven tooth 11 prior to inspection at reading 2199. From Fig. 11, FM4 and NA4 both indicate an increase in magnitude at approximately reading 1700. As seen previously, both become less sensitive to damage as it progresses.

Experiment 4 is plotted in Figs. 12 to 13. Damage progression is shown in Table III and Fig. 6. Destructive pitting occurred on driver and driven teeth 1 and 28 prior to inspection at reading 2669. From Fig. 13, FM4 and NA4 both indicate an increase in magnitude prior to inspection at reading 2669 and become less sensitive to damage as it progresses.

As seen in Figs. 7 to 13, NA4 does react to pitting damage. However, some of the response magnitude is lost with the reset operation. The NA4 reset does increase the stability of the

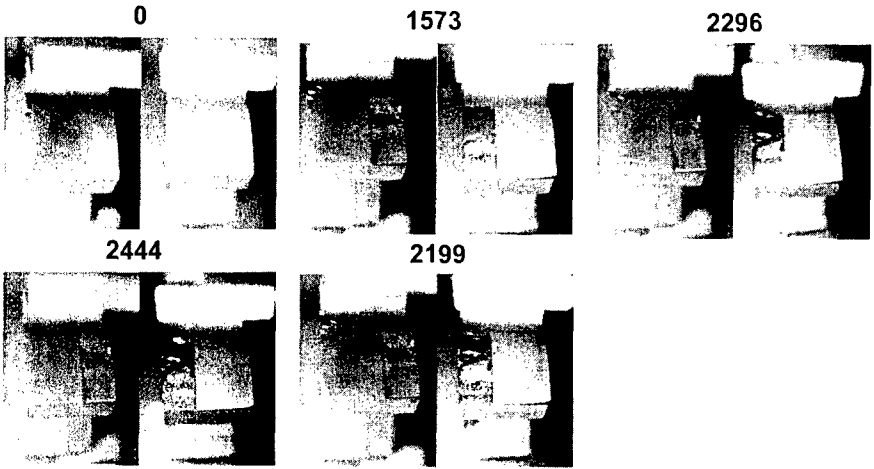

Figure 5.—Damage progression of driver/driven tooth 11 for experiment 3.

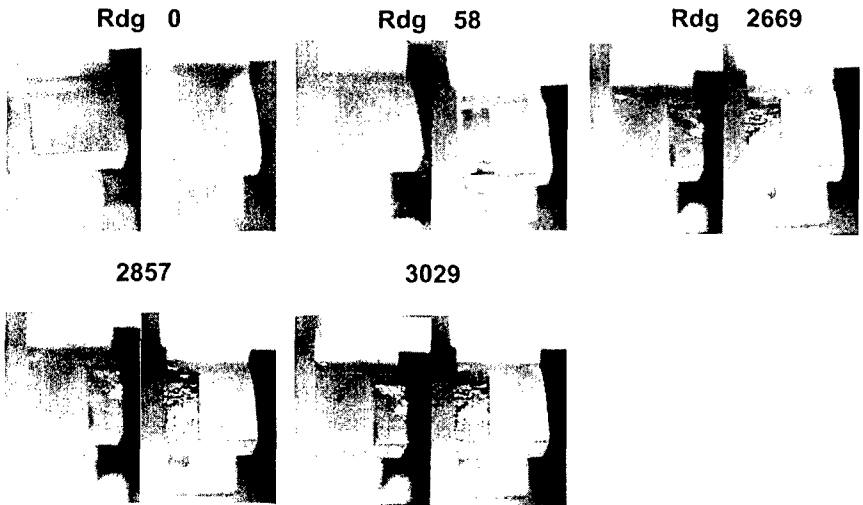

Figure 6.—Damage progression of driver/driven tooth 28 for experiment 4.

NA4 parameter enabling it to have a more consistent threshold limit. This is a key critical factor in reducing false alarm rates.

Conclusions: Operational effects, such as load and speed fluctuations, can adversely impact vibration diagnostic parameters and result in an unacceptable level of false alarms. To minimize this, current practice is to reduce the sensitivity of the vibration-based-diagnostic

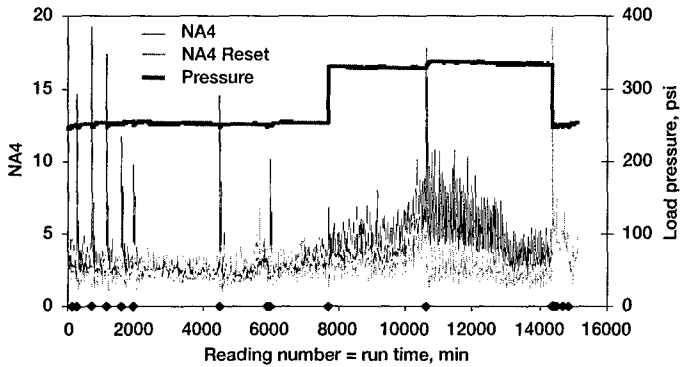

Figure 7.—Data from experiment 2 illustrating load and shutdown effects.

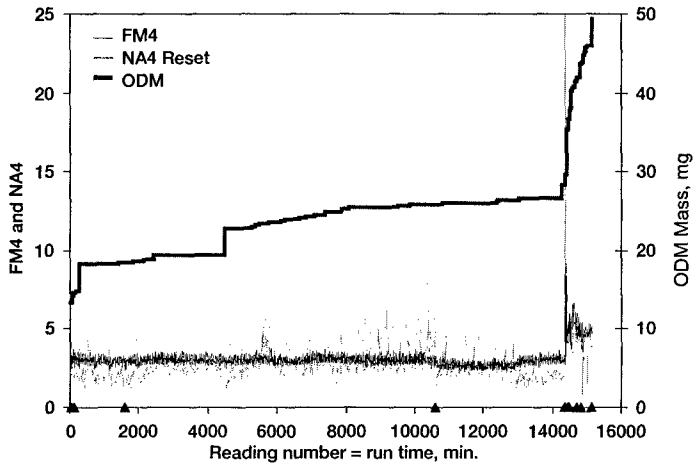

Figure 8.—Vibration, ODM, and damage data from experiment 2.

techniques. However, this also results in a decreased sensitivity of these techniques to actual damage.

The goal of this research was to minimize the effect of load on the vibration-diagnostic-parameter NA4 while maintaining its sensitivity to pitting damage. Results indicate the NA4 reset is no longer sensitive to load changes but is still sensitive to pitting damage. Both NA4 reset and FM4 indicate when destructive pitting occurs on one gear tooth. The NA4 reset, like the FM4, is less sensitive to damage as it progresses to a number of teeth and increases in severity. The magnitude of NA4 reset is less than NA4 when pitting damage occurs requiring a smaller threshold limit to indicate pitting damage. However, the magnitude of NA4 reset is significantly larger than FM4 when pitting damage begins to occur. It should be noted that successful implementation of NA4 reset requires a signal that can be

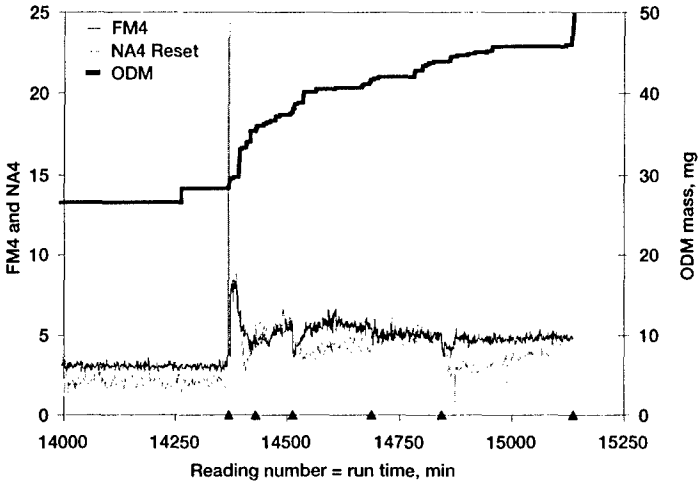

Figure 9.—Vibration, ODM, and damage data from experiment 2.

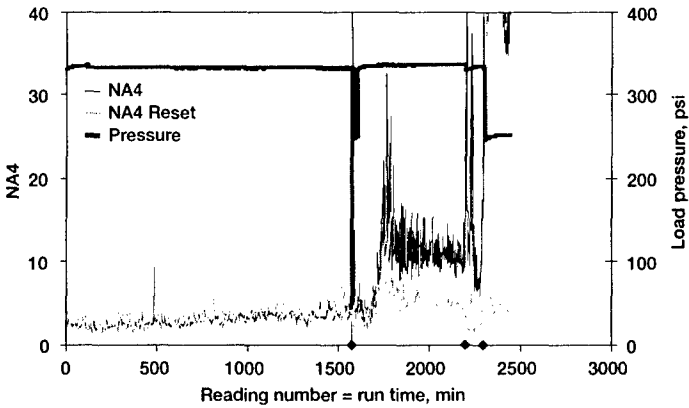

Figure 10.—Data from experiment 3 illustrating shutdown and load effects.

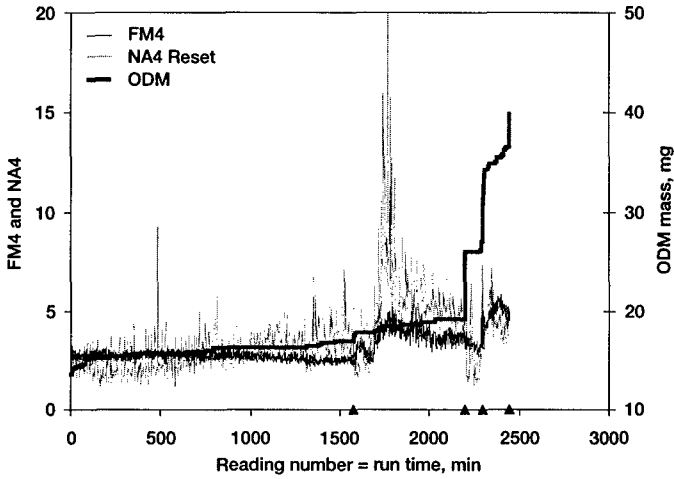

Figure 11.—Vibration, ODM, and damage data from experiment 3.

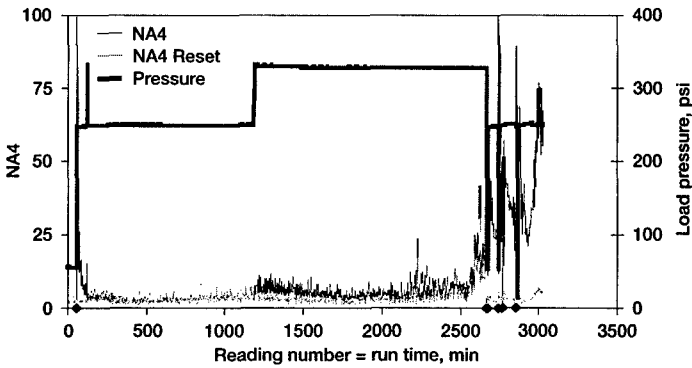

Figure 12.—Data from experiment 4 illustrating shutdown and load effects.

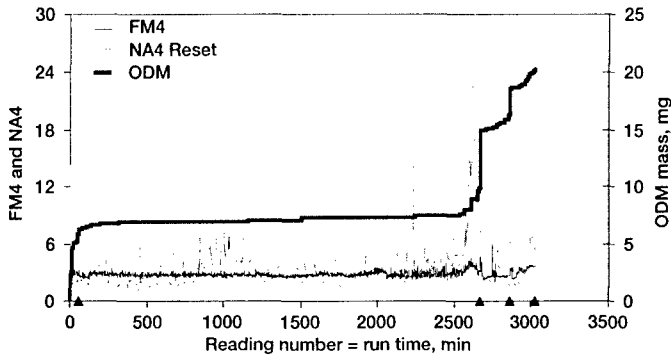

Figure 13.—Vibration, ODM, and damage data from experiment 4.

directly correlated to torque load. Additional research is required to define alert and fault threshold limits for vibration algorithm NA4 reset.

References

1. Zakrajsek, J.J.; Townsend, D.P.; and Decker, H.J.: An Analysis of Gear Fault Detection Methods as Applied to Pitting Fatigue Failure Data. NASA TM-105950, 1993.
2. Zakrajsek, J.J.; Handschuh, R.F.; and Decker, H.J.: Application of Fault Detection Techniques to Spiral Bevel Gear Fatigue Data. NASA TM-106467, 1994.
3. Zakrajsek, J.J.; Decker, H.J.; Handschuh, R.F.; Lewicki, D.G.; and Decker, H.J.: Detecting Gear Tooth Fracture in a High Contact Ratio Face Gear Mesh. NASA TM-106822, 1995.
4. Lewicki, D.G., and Coy, J.J.: Helicopter Transmission Testing at NASA Lewis Research Center. NASA TM-89912, 1987.
5. Lynwander, P.: Gear Drive Systems Design and Application. Marcel Dekker, Inc., New York, NY, 1983.
6. Zakrajsek, J.J.; Townsend, D.P.; Oswald, F.B., and Decker, H.J.: Analysis and Modification of a Single-Mesh Gear Fatigue Rig for Use in Diagnostic Studies. NASA TM-105416, 1992.
7. Dempsey, P.J.: A Comparison of Vibration and Oil Debris Gear Damage Detection Methods Applied to Pitting Damage. NASA TM-210371, 2000.
8. Howe, B.; and Muir, D.: In-Line Oil Debris Monitor (ODM) for Helicopter Gearbox Condition Assessment, January 1, 1998.
9. Stewart, R.M.: Some Useful Data Analysis Techniques for Gearbox Diagnostics. Report MHM/R/10/77, Machine Health Monitoring Group, Institute of Sound and Vibration Research, University of Southampton, 1977.
10. Rock, D., Malkoff, D.; and Stewart, R.: AI and Aircraft. AI Expert, Feb. 1993, pp. 28-35.
11. Zakrajsek, J.J.; Decker, H.J.; and Handschuh, R.F.: An Enhancement to the NA4 Gear Vibration Diagnostic Parameter. NASA TM-106553, 1994.