

UNCLASSIFIED

Defense Technical Information Center
Compilation Part Notice

ADP011838

TITLE: Removal of Hall Sensor Offset to Achieve Stable Spindle-Motor Loop in a CD System

DISTRIBUTION: Approved for public release, distribution unlimited

This paper is part of the following report:

TITLE: Optical Storage and Optical Information Held in Taipei, Taiwan on 26-27 July 2000

To order the complete compilation report, use: ADA399082

The component part is provided here to allow users access to individually authored sections of proceedings, annals, symposia, etc. However, the component should be considered within the context of the overall compilation report and not as a stand-alone technical report.

The following component part numbers comprise the compilation report:

ADP011833 thru ADP011864

UNCLASSIFIED

Removal of Hall Sensor Offset To Achieve Stable Spindle-Motor Loop In A CD System

Chi-Cheng S. Lin, Wai W. Wang, Shun-Yi Tung, Chin-Hong Lin
Storage Devices Division, Acer Peripherals, Inc.
157, San-Ying Road, Kwei-Shan, Taoyuan, Taiwan

I. Introduction

Brushless spindle motor is one of the most important key components used in a CD system. A stable spindle motor control loop is essential to assure reliable data integrity for a high-speed CD drive. However, DC offset is frequently observed on Hall sensors of the spindle motor used in a CD system. This spindle-motor Hall sensor offset also shows large range variation among batches from different motor suppliers. This undesired Hall sensor DC offset can induce unstable spindle-motor control loop and cause malfunction of a CD drive. Being a drive manufacturer to mass produce CD drives over one million unit per month, the problem of Hall sensor offset variation must be overcome to assure smooth operation of the mass production.

As the demand on CD technology continues toward higher data transfer rate, the demand on spin rate stability of a spindle motor continues its advance. The increase of spin rate requires higher power consumption of a spindle motor and excessive heat is generated. This excessive heat aggravates the offset drifting in the Hall sensor and also induces amplitude shrinkage of Hall sensor signals. This undesired offset variation results in timing jitter of spindle-motor timing driving sequence to induce unstable spindle-motor loop in a CD system. In this paper, a practical solution is proposed to remove the offset completely, and thus, to achieve a very stable spindle loop.

II. Experiment result and discussion

The equipment used in this experiment are ACER CD640A CD-ROM drive and ACER CDRW 8432A rewritable drives which writes CD-R disc at 8X, writes CD-RW disc at 4X, and playback at 32X.

Stable spindle-motor control loop is essential to assure a properly functional CD system. To achieve this goal, Hall sensor output free of DC offset and close to 50-50% duty cycle timing sequence of motor driving signal is essential to achieve a stable spindle-motor loop. In reality, most of the spindle motors cannot be free of Hall sensor DC offset due to design and manufacturing process. As shown in Fig. 1, a typical Hall sensor output of a spindle motor shows DC offset. This DC offset results in the timing sequence of the motor driving signal deviated from 50-50% duty cycle. Larger jitter (Fig. 2) on timing sequence of motor drive is also observed. When the DC offset severely deviates out of the design margin of the spindle motor loop, malfunction would occur to knock down the CD system. Fig. 3 shows the Hall sensor DC offset is removed and the duty cycle of motor driving sequence is close to be 50-50%. This is accomplished through the implementation of the technique proposed in this paper. Jitter performance is also improved after the Hall sensor DC offset is removed, as shown in Fig. 4.

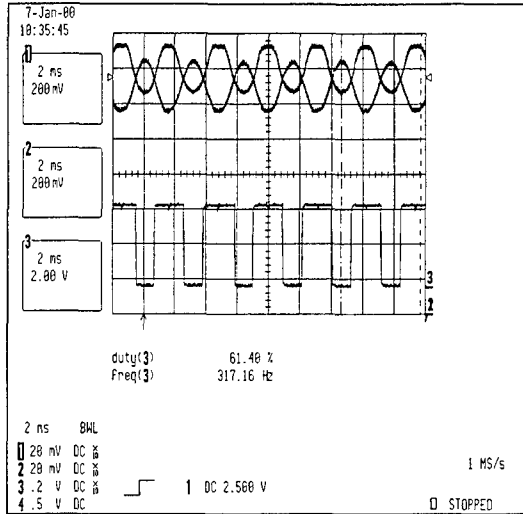

Fig. 1 Hall sensor offset causes motor drive timing sequence deviated from 50-50% duty cycle.

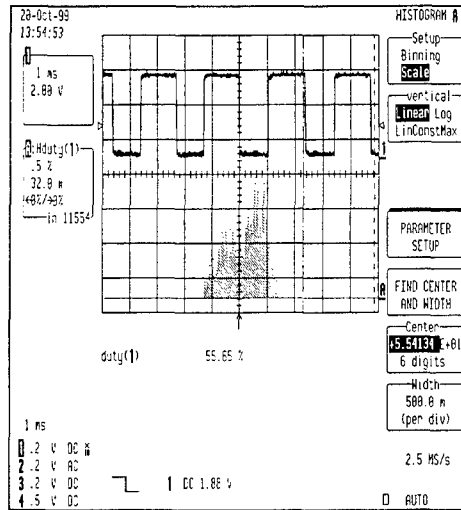

Fig. 2 Jitter is larger with DC offset existing.

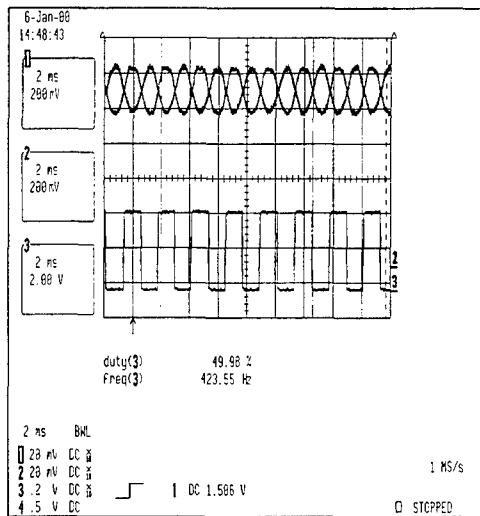

Fig. 3 Hall sensor DC offset is removed and 50-50% duty cycle is achieved.

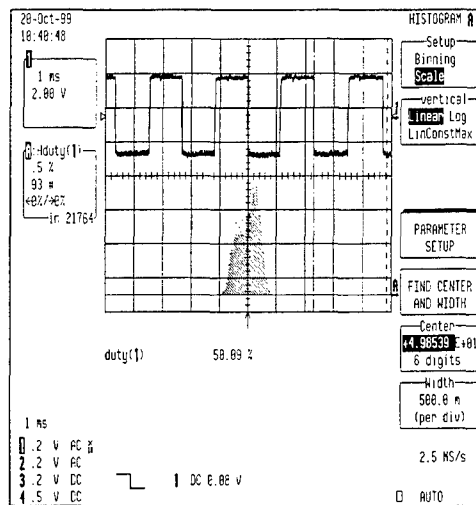

Fig. 4 Jitter spreading is reduced while Hall offset is removed.

As spindle motor is driven toward higher speed to cause higher power consumption, excessive heat is thus generated to induce higher temperature imposed onto the spindle-motor. Higher temperature not only aggravates the DC offset variation but also causes the shrinkage of Hall sensor output signal. This leads to degradation of signal-to-noise signal of Hall sensor output and worsen the duty cycle balance of motor driving sequence. The technique to overcome the Hall signal shrinkage by using differential comparator is reported before¹. In this paper, the focus is more on Hall sensor offset removal.

Figure 4 shows the Hall sensor DC offset is removed after the implementation of the technique proposed in this paper and 50-50% duty cycle of motor driving sequence is also achieved. Further, improvement on jitter performance is also observed as shown in Fig. 4. The functional block diagram of the motor control loop with the proposed AC-coupled technique is installed, as shown in Fig. 6. To remove the DC offset of Hall sensor, AC-coupled method is used to filter out the DC portion of Hall sensor signals. This AC-coupled Hall sensor can only be enabled after the spindle-motor is initialized reaching to a desired speed level. At that moment, AC-coupled of Hall sensor can thus be enabled to assure smooth operation of spindle motor (Fig. 6). A timing delay to enable the switch is essential to assure the AC-coupled circuit to function properly.

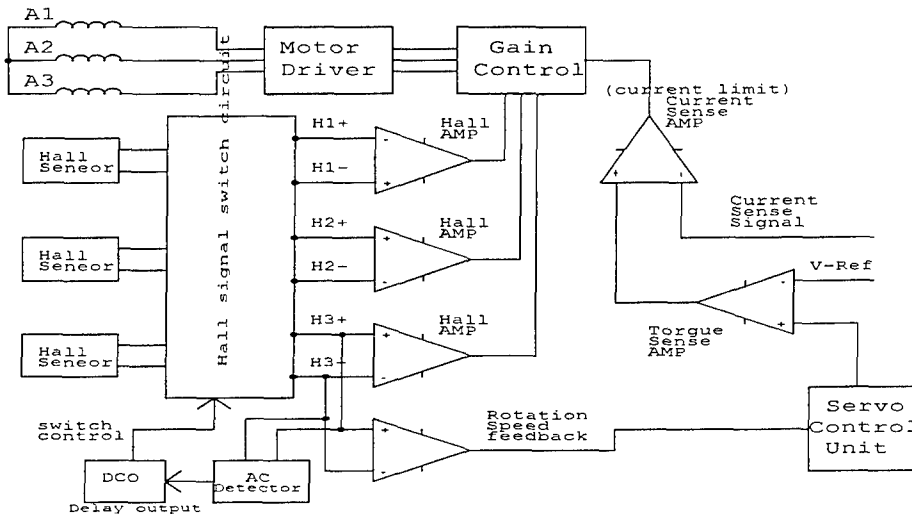

Figure 5 shows the functional block diagram of the motor control loop with AC-coupled Hall sensor.

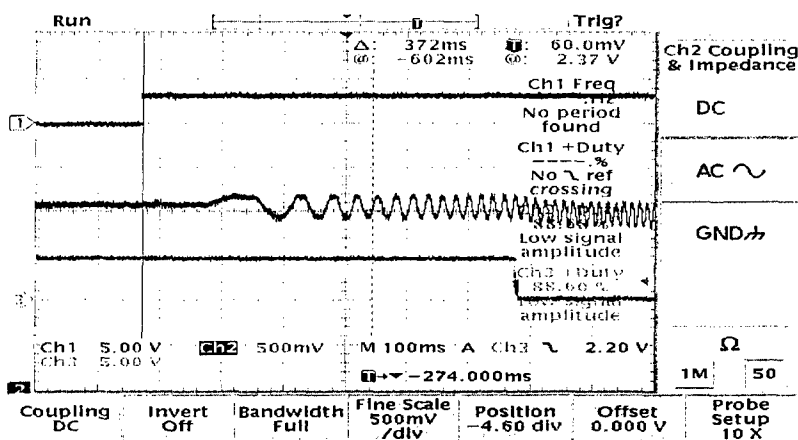

Fig. 6 Upper: Spindle motor power is enabled.
Middle: Hall sensor signals.
Lower: AC-coupled switch is enabled.

III. Conclusion

A practical solution of AC-couple Hall sensor in a spindle motor control loop to effectively eliminate the DC offset is proposed. This solution effectively removes the DC offset of Hall sensor and improved the stability of spindle-motor loop in a CD system.

Reference

[1] C.-C. Steve Lin, Cai-Gang Xu, W.-L. Tang, Wai. W. Wang, Y.-D. Hu, and K.-C. Cheng, "Thermal interference on a spindle motor and a method of correction in a CD-ROM system" Proceeding of the 13th Conference on Magnetism & Magnetic Technologies, pp. 213-215, July 1998.