

COMPONENT PART NOTICE

THIS PAPER IS A COMPONENT PART OF THE FOLLOWING COMPILATION REPORT:

TITLE: Minutes of the Explosives Safety Seminar (22nd) Held in Anaheim,  
California on 26-28 August 1986. Volume 2.

TO ORDER THE COMPLETE COMPILATION REPORT, USE AD-A181 275.

THE COMPONENT PART IS PROVIDED HERE TO ALLOW USERS ACCESS TO INDIVIDUALLY AUTHORED SECTIONS OF PROCEEDING, ANNALS, SYMPOSIA, ETC. HOWEVER, THE COMPONENT SHOULD BE CONSIDERED WITHIN THE CONTEXT OF THE OVERALL COMPILATION REPORT AND NOT AS A STAND-ALONE TECHNICAL REPORT.

THE FOLLOWING COMPONENT PART NUMBERS COMPRISE THE COMPILATION REPORT:

AD#: P005 350 thru P005 393 AD#: \_\_\_\_\_  
AD#: \_\_\_\_\_ AD#: \_\_\_\_\_  
AD#: \_\_\_\_\_ AD#: \_\_\_\_\_

Accession For	
NTIS GRA&I	<input checked="" type="checkbox"/>
DTIC TAB	<input type="checkbox"/>
Unannounced	<input type="checkbox"/>
Justification	
By _____	
Distribution/	
Availability Codes	
Dist	Avail and/or Special
<u>A-1</u>	

This document has been approved for public release and sale; its distribution is unlimited.

AD-P005 366

WARTIME MISSION OF  
EXPLOSIVES SAFETY

Capt Susan J. Kaufman, USAF  
Air Staff Office of Safety  
& Nuclear Surety  
AF/IGF  
Room 5D273, The Pentagon  
Washington D.C. 20330-5100  
AV 227-7050  
Comm (202) 697-7050

## I. INTRODUCTION

The Air Force concept of explosives risk management has undergone major revision since 1983. The changes have been across the entire spectrum of safety management, from installation level analysis of the risk involved in specific explosives operations, to Secretary of the Air Force authorization of some explosives safety violations. In addition, safety factors in all combat explosives operations have been scrutinized in light of shifting from peacetime to wartime acceptable risk levels. Prior to 1983, installation level weapons safety officers had access to little specific information concerning the degree of risk to personnel and equipment. Air Force Regulation 127-100, Explosives Safety Standards, had tables that stated required separation distances for given net explosive weights, but if these distances could not be met, the safety officer had no quantitative way of expressing the additional degree of risk incurred. The only information provided to the commander was "this situation does not meet explosives safety standards." No attempt was made to determine the increased risk to the unit war fighting capability. In effect, the unit commander made decisions to violate DOD acceptable risk levels with no real knowledge of the impact of a mishap or enemy attack. In order to increase field level knowledge of explosives blast and fragment effects, the Air Force Inspection and Safety Center revised AFR 127-100 under a risk management concept. This paper outlines the development of this concept, its application at the field level, and its contribution to the Air Force warfighting capability.

## II. Q-D and Probability

Quantity-distance criteria are the backbone of explosives safety risk assessment, in that they associate a given distance and explosives weight with the principal effects of blast overpressure and fragments. These criteria have been derived from empirical methods and, therefore, quite accurately determine the required separation for an assumed or permitted level of risk. The standard level of risk allowed for each type of exposed site is established by the Department of Defense to assure adequate protection of personnel and assets consistent with overall objectives. (1) Consequently, when deviating from these standards, proper authority within the Air Force must weigh the added risk against the strategic, or other compelling reasons that require such deviations.

The basic philosophy of explosives safety is that locations containing explosives, or potential explosive sites (PES), must be separated from each other and from other surrounding facilities and equipment, known as exposed sites (ES). This separation of the PES from the ES is referred to as quantity-distance (Q-D), and is based on a worst-case accident, known as the maximum credible event (MCE). The MCE, is expressed as the net explosives weight (NEW) which may be expected to react in a single event. These separations are determined by the formula  $D = kW^{1/3}$  when D is the distance in feet, k is a factor identifying the risk assumed or permitted, and W is the NEW in pounds. With the known responses of individual ESs, (such as bombs, humans, aircraft,

facilities, etc) to specific levels of stimulus, a safe separation, i.e., assumed level of risks may be readily determined. DOD Q-D relationships define the acceptable risk with the assumption that the maximum credible event (MCE) will occur, that is the probability of occurrence is unity. An argument can be made that MCE=1 is not consistent with actual mishap experience. However, to use a probability of less than one requires some predetermination of how many times such an event is acceptable over a period of time, and how much loss one is willing to incur. That is the heart of the anomaly. Calculable disastrous results can't be acceptable on a probability basis, or more specifically, the DOD has not defined such acceptance. Thus, the central interest of risk assessment is the MCE, understanding what contributes to it, what will not contribute to it, and ultimately, measures that can be taken to limit or control it.

### III. Hazard Properties

To pursue definition and control of the MCE, we must examine two specific hazardous properties of an explosion, blast and fragments. Testing has shown that the same blast overpressure is obtained at a distance proportional to the cube root of the weight of explosives involved in a detonation.

$$\frac{D_1}{W_1^{1/3}} = \frac{D_2}{W_2^{1/3}} = k$$

This is the derivation of K in the  $D=kW^{1/3}$  formula used in Q-D calculations. A k-factor, then, indicates the level of overpressure, regardless of the quantity of explosives. This is a very useful concept as a k-factor (associated with a specific overpressure level) can readily be used to define expected damage at an ES. (Also note, the larger the k-factor, the greater the required distance.) Figure 1 is an example of several k-factors, and the associated PSI overpressure. Safe separation distance required is proportional to the NEW. With respect to the MCE, any method that demonstrates the ability to suppress blast may reduce the associated k-factor, thus reducing the required distance. For example, the standard earth-covered igloo functions as a blast suppresser, and a lesser k-factor is associated with this type of storage than would be used for the same explosives weight in above-ground (unsuppressed) open storage. Fragments on the other hand, exhibit different damage properties than blast. The DOD defines a lethal fragment as having 58 ft-lbs impact energy. The allowable hazardous fragment density to ESs not directly related to the combat mission is one per 600 feet. This can also be expressed as a probability of hit of less than 1%. Past explosives testing has demonstrated that in general, any amount of explosives between 100 and 30,000 pounds will propel lethal fragments 1250 feet. For a specific weapons configuration, the risk assessor must carefully compare the hazards from blast and fragments. (Figure 2)

There is another factor to consider in controlling a maximum credible event. If the risk assessor determines blast as the primary hazard, care must be taken to ensure that measures to suppress the blast do not contribute to the fragment hazard. This phenomena is demonstrated by hardened aircraft shelters (HAS). A HAS is constructed of reinforced concrete and heavy blast doors to resist overpressure from the outside, i.e., an enemy attack, and allow survivability

of the aircraft inside. For the purposes of risk assessment, one must consider the reverse situation. If the explosion occurs on the inside of a HAS, such as a weapons loaded aircraft accident, the failure mode of the heavily reinforced HAS walls contributes significantly to the fragment hazard. Explosives testing has demonstrated the need for increased k-factors for explosives if they are positioned inside a HAS.(2)

#### IV. Q-D Categories

We have demonstrated the proportionality between NEW, blast overpressure and distance. We must now turn our attention to the DOD mandated implementation of this principle.

Basically there are two cases to consider. The first case involves a sufficient degree of separation between neighboring PES, and the second case involves nonexplosive exposed sites, including facilities, work areas, roads, aircraft, equipment, etc., in the proximity of explosives storage, maintenance or employment areas.

**Inhabited Building Distance (IB):** This is the largest Q-D separation and is designed to protect civilian or unrelated base structures from blast and fragments. Associated k-factors range from 35 to 60.

**Public Traffic Route (PTR):** This Q-D separation applies to off-base roads, railroads, recreation areas and training areas. PTR is a lesser distance than IB, but still provides some protection from blast and fragments. Associated k-factors range from 24 to 30.

**Intraline (IL):** This separation is applied in several situations. It is used between explosive locations and maintenance areas where personnel are present as well as between explosives loaded aircraft and aircraft generation related facilities. It provides some protection from blast, but no fragment protection. The associated k-factor is usually 18.

**Intermagazine (IM):** This is the smallest Q-D separation, and it is used between explosives storage locations, and weapons loaded aircraft. It is the minimum distance required to prevent sympathetic detonation or propagation of explosion between PESs. It provides no fragment protection. The K-factor varies widely with the storage or employment situation, and ranges from 1.25 to 11.

Figure 3 is a summary of the Q-D separation categories, overpressure levels, and expected damage. This provides the basic tools of risk assessment.

In peacetime, the main thrust of explosives safety has been to protect civilians and unrelated base facilities from blast and fragments. In fact, the Secretary or Undersecretary of the Air Force must approve any Q-D violations involving off-base ESs. A lower level of approval authority, generally at the AF Major Command is mandated for on-base violations. Therefore, at most Air Force locations, the funding priorities for correction of explosives safety problems tend to favor eliminating off-base civilian ESs. In other words, enforcement of IB and PTR distances would appear to have priority over IL and IM requirements when working an explosives safety issue.

This has led to the impression that explosives safety is a peacetime function for protection of the civilian populace and has no real use for wartime operations. This is a serious misconception, and may adversely impact our warfighting capability if not alleviated. Explosives safety does, of course, have a peacetime obligation to limit loss of life and property damage, but it's really critical mission is preservation of combat capability. To understand the wartime mission, we must carefully examine the role of IL and IM Q-D separations in risk assessment.

## V. RISK ASSESSMENT

To examine the value of installation level risk assessment, we will consider an accident that occurred 27 April 1969, at Danang AB, Vietnam. At 1030 on the morning of the accident, a security policemen observed a fire in the southeast corner of the Marine ammunition storage point (ASP), which was located next to USAF ASP-1 (See Fig 4). Attempts to fight the fire were unsuccessful, and the fire spread. Small explosions were heard, and burning debris was observed coming into USAF ASP-1. For the next seven hours, explosions spread throughout the Marine ASP, hurling large shrapnel fragments into USAF ASP-1 and starting small fires. (Figure 5) Delivery of munitions to the flightline stopped. At 1700, the initial explosion occurred at USAF ASP-1. An hour later, approximately 19 ammunition storage cells were destroyed (cratered, burning or buried). The explosions continued with diminishing intensity throughout the night.

The Marine ASP was almost completely destroyed. The USAF ASP-1 experienced extensive damage; the explosions destroyed or buried over 2.5 million pounds net explosives weight, and incurred costs of approximately \$5 million in facility repair (1969 dollars).

The two ASPs show very different damage patterns. The Marine ASP was completely destroyed, while damage to the USAF ASP-1 was limited. A comparison of the storage practices of the two services will account for the differences in the resulting damage. Figure 6 is a photograph of typical Marine ammunition storage at Danang AB. There were not enough storage revetments available, and ammunition was stacked in between the rows of revetments. This was a violation of established intermagazine distances and barricade (suppression) criteria. As a result, an explosion in one revetment propagated to the next revetment and so on. The improper storage rendered the revetments useless in suppressing sympathetic detonation and explosives propagation, and the entire Marine ASP was destroyed.

As mentioned in the account of the accident, burning debris and shrapnel were propelled from the Marine ASP into USAF ASP-1. The first high order detonation in the USAF area occurred approximately seven hours after the fire started. Figure 7 illustrates typical damage to USAF revetments. Out of 60 cells, 13 detonated high order, 4 burned, and 8 were buried. Although there are two sets of craters in adjoining revetments (row G, 8 & 9, and 5 & 6) eye witness testimony established that they were individual detonations caused by and shrapnel from the Marine ASP and, one did not propagate to the other. Some munitions items were improperly stored in between the revetments, and one stack of 2.75" rockets detonated sympathetically with the MK 82s in row G cell 5. (Figure 8)

The destruction of the Marine ASP compared to the more limited damage pattern in USAF ASP-1 is a good example of the role risk assessment plays in preserving the resources associated with combat capability. If munitions in USAF ASP-1 had not been properly warehoused very probably all 60 cells of munitions would have been lost instead of the 19 experienced in this mishap. Although this accident occurred from an accidental fire, an enemy attack could have produced similar results. Failure to follow intermagazine separations in a wartime situation can lead to a complete loss of combat capability.

## VI. PLANNING FOR THE WARTIME MISSION

Reviewing the results of the Marine ASP disaster, and its impact on the Danang AB military operations, illustrates the importance of planning for preservation of combat capability. A weapons safety officer's responsibility to his commander is the identification of situations which have the potential to degrade warfighting ability.

When a Q-D problem is identified, several courses of action are possible. Reducing the Q-D by separating the explosives into smaller stacks may solve the problem. Figure 9 is an example of a 60,000 pound PES with an inhabited building ES violation. By separating the 60,000 pound PES into 2 stacks of 30,000 pounds spaced at intermagazine distance (to prevent propagation), the clear zone is reduced to accommodate the inhabited building ES. If this is not possible, an attempt may be made to suppress the mishap effects at the PES or the ES. Suppressing the mishap effects at the PES is difficult, because reinforcing or hardening explosives storage buildings may contribute to the fragment hazard, as evidenced in the HAS example earlier in this paper. However, earth barricades may be constructed at a PES and reduce Q-D requirements in some cases. Hardening at the ES may be as simple as protection with sandbagging, or may involve expensive real property modifications to walls and roofs. If smaller quantities of explosives or suppressing mishap effects are impractical, an explosives safety exception may be required.

Figure 10 outlines the steps the weapons safety officer follows in determining the degree of risk to the exposed sites. When the overpressure level is calculated, the chart at Figure 11 is used to predict the damage, and the resulting mission impact is provided to the Commander.

The weapons safety officer concentrates on three primary areas of activity; the weapons storage area, the flightline, and facility site planning.

Proper storage of ammunition is critical, as the Danang AB accident graphically illustrated. The weapons safety officer must constantly inspect all munitions storage areas for compliance with quantity-distance criteria. These inspections must also include general industrial safety and fire prevention efforts. If the military unit's mission calls for delivery of additional ordnance for specific combat scenarios, the weapons safety officer must ensure that the weapons storage area is capable of properly storing the ordnance as it is delivered, and provisions are made for build-up areas that will meet quantity-distance requirements.



On the flightline, review of aircraft parking plans and aircraft loading procedures is essential. An aircraft loaded with munitions is an explosives hazard, presenting a risk assessment problem similar to the storage situation. The aircraft must be positioned an adequate distance apart or barricaded to prevent an explosion of one propagating neighboring aircraft. This situation is often complicated with delivery of munitions to the flightline, and the position of explosives holding areas relative to the aircraft. The wing weapons safety officer must carefully analyze generation flow plans and explore ways to reduce risk by regrouping aircraft, or changing the sequence of aircraft loading. In the dynamic world of aircraft maintenance, on the spot risk assessment decisions may be necessary during wartime operations as aircraft are generated. If wartime clear zones must be expanded beyond peacetime limits, wing war plans should ensure provisions for evacuation of inhabited facilities exist. If functions not directly related to the combat aircraft generation activities can be temporarily relocated, capacity of hardened aircraft shelters and flightline holding areas may be increased.

Facility site planning is another area critical to wartime survivability. The obvious case is intermagazine and intraline spacing of facilities in the weapons storage area. However, many survivability gains can be made by planning flightline maintenance facilities and work areas. For aircraft generation facilities that must be near the flightline, design features can be incorporated into the construction plans to reduce the risk to personnel and equipment. Simple things, such as orienting windows and doors away from the ESs will greatly reduce personnel injury flying glass and debris. More expensive modifications, such as hardened roofs, reinforced walls or earth barricades may be feasible for protection of especially valuable test equipment or spare parts. Another aspect, often overlooked in long range planning, is natural terrain. Although airfields are generally "pool tables", it may be possible to position aircrew facilities, maintenance areas or supply warehouses into the sides of hills or underground where susceptibility to blast and fragment hazard is greatly reduced.

Many research and development projects and quantity distance tests are underway to develop technological solutions to explosives safety problems. Currently the Air Force is testing high explosive general purpose (GP) bomb propagation using inert material and low explosive cluster bombs as barricades (3). In some cases, stacking the barricade materials between stocks of GP bombs will increase the explosives storage capacity of igloos 2 or 3 times without increasing the risk of propagation. Also, testing of other munitions has demonstrated configurations and containers that prevent explosive propagation. Future test efforts of inventory items will be focused on real world Q-D problems encountered during wartime aircraft generation scenarios. Another research and development program is designing barricade materials that can be positioned within explosives pallets or, or between explosives stores loaded on aircraft (4). This will reduce the MCE to the explosion of one bomb, allow for greater flexibility on aircraft generation flow plans. A long range goal is development of an insensitive high explosive (IHE.) An IHE is an explosive that is so insensitive, an explosion or a fire will not cause sympathetic detonation or propagation. This will be a breakthrough in reducing the maximum credible event, but it is quite far in the future, and existing stocks of conventional munitions will complicate Q-D requirements.



## VII. CONCLUSION

Although creative Q-D testing and technology efforts are aimed at reducing the MCE, there is no foreseeable panacea for eliminating the risk of accidental explosive propagation from wartime operations. Written plans usually contain Annex N, which is the Safety Annex. This is an excellent format for weapons safety officers to document localized risk assessment considerations, and provide planners with information critical to survival of the combat capability. Review of base comprehensive plans maintained by civil engineering, and long-range military construction project submittals with an effort to preserve existing clear zones and maintain Q-D separations will minimize future risk management problems.

Wing weapons safety officers must be trained in risk assessment concepts, and work closely with operations personnel, maintenance and civil engineering community planners. It is not an easy job, and many difficult risk management decisions must be made by the wing commander.

## FOOTNOTES

- (1) This guidance is found in DOD 6055.9-STD, Ammunition and Explosives Safety Standards. Specific Air Force implementation is found in AFR 127-100, Explosives Safety Standards.
- (2) This was established by the Distant Runner test, 1982.
- (3) This series of tests involving bulk storage of GP bombs started in 1985 and is still in progress.
- (4) This project is known as HAVE BLOCK. Tests started in 1984, and are still in progress.

**OVERPRESSURE**

27.0

3.6

1.2

**K-FACTOR**

6

18

40

Figure 1

# PRIMARY HAZARDS ASSOCIATED WITH EXPLOSIVES

○ DISTANCE REQUIRED FOR NET EXPLOSIVE WEIGHT (NEW)

— BLAST (GREATER THAN 1.2 PSI OVERPRESSURE - BROKEN GLASS/TEMP HEARING LOSS)

--- FRAGMENTS (ONE LETHAL FRAGMENT IN 600 SQ FT)

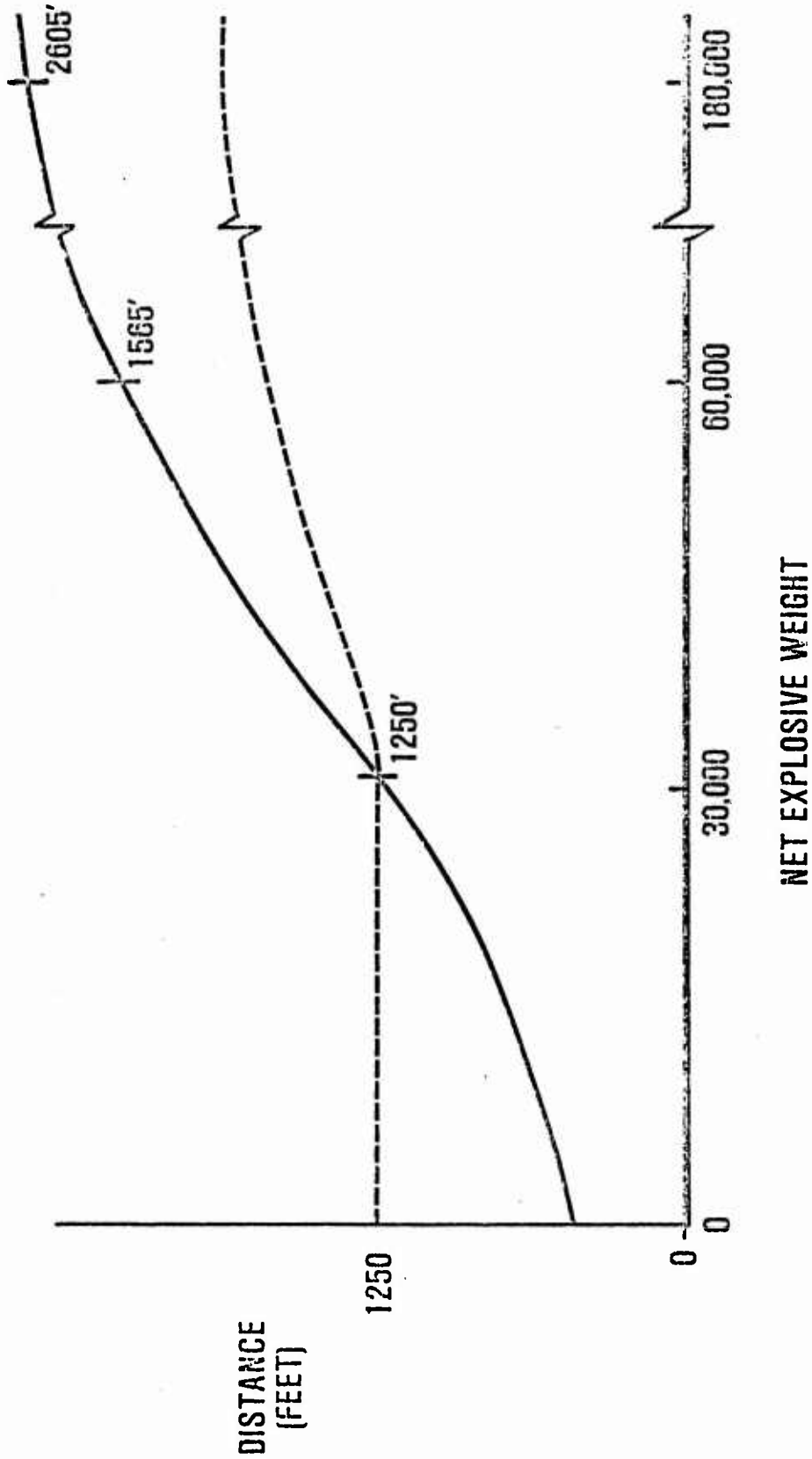

Figure 2

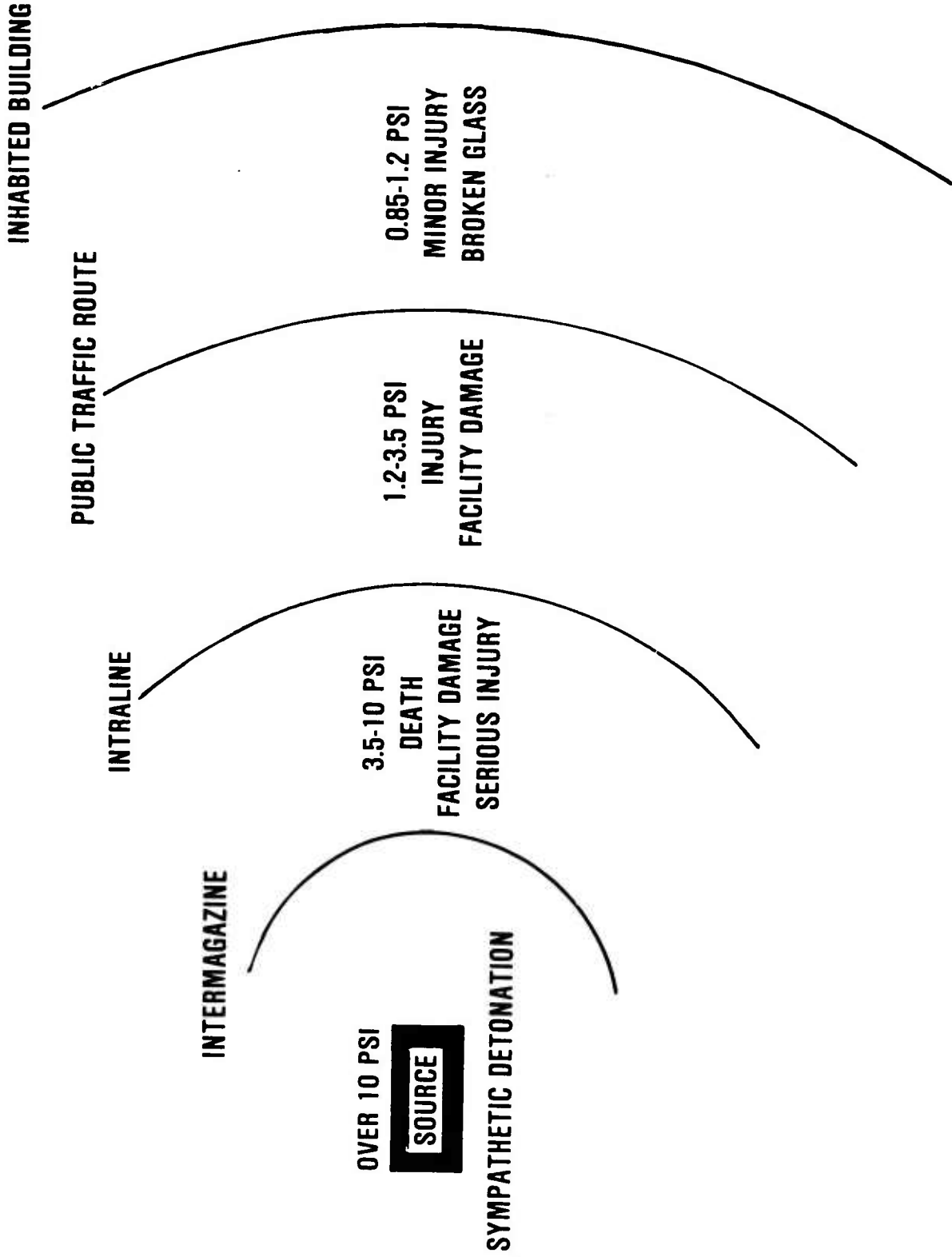
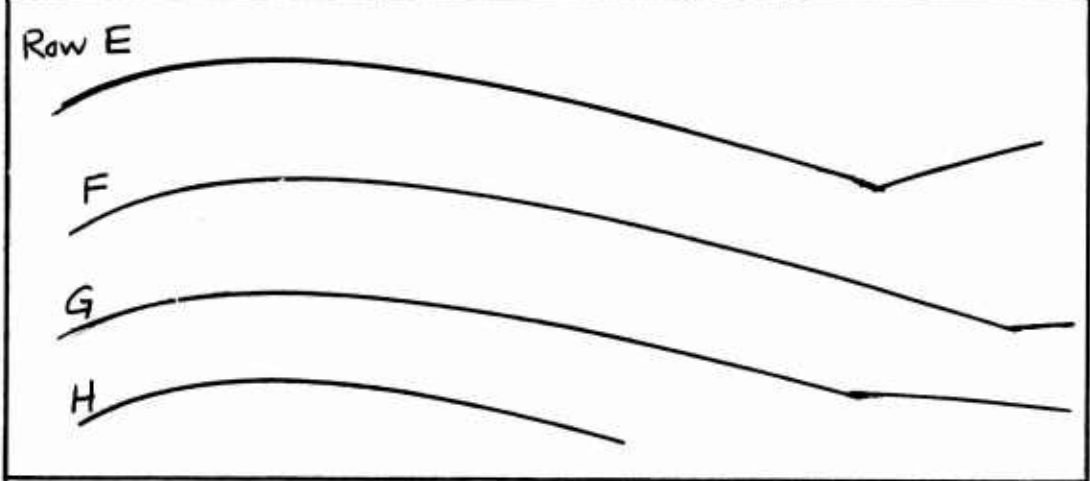
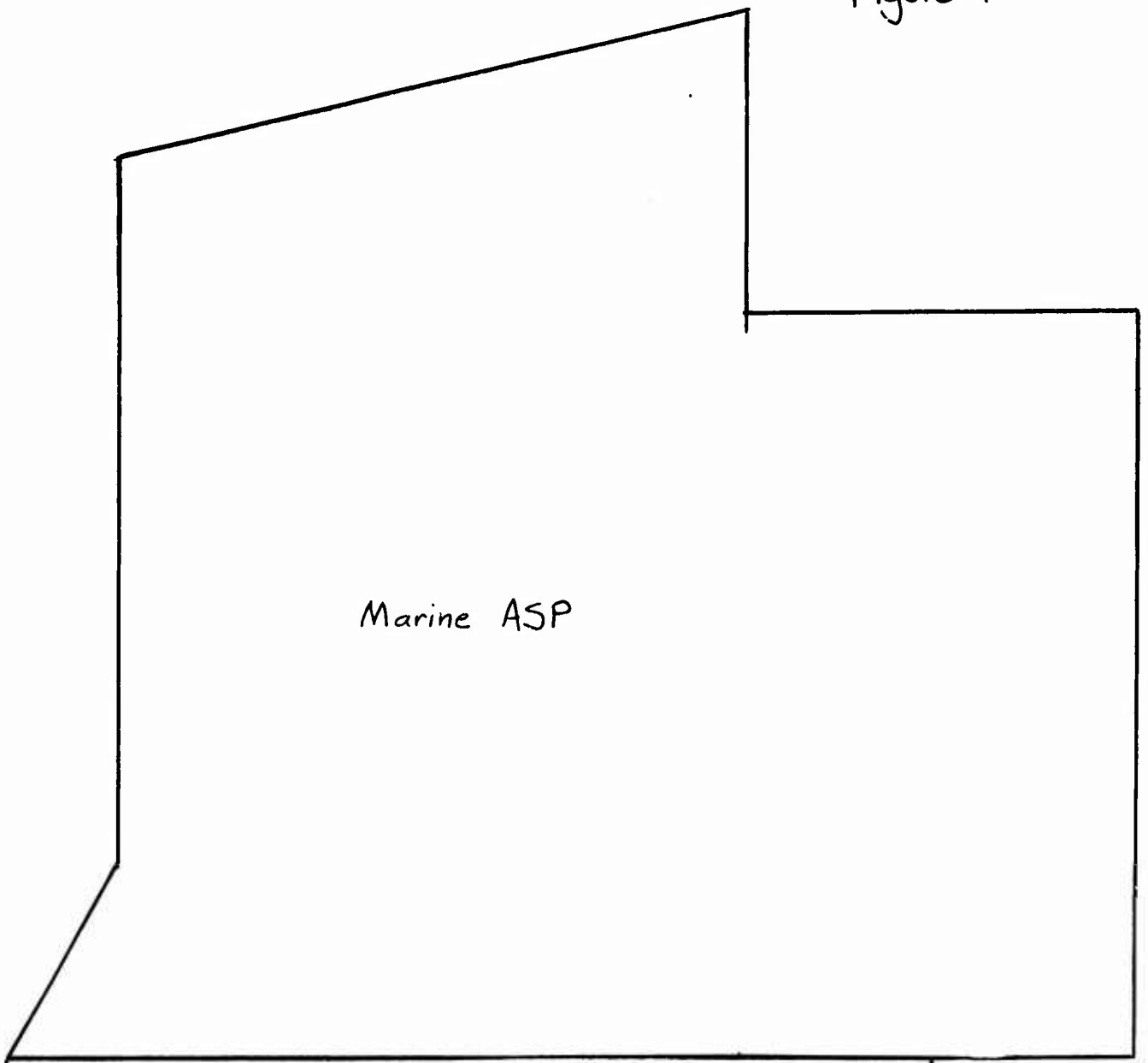

Figure 3

Figure 4



Air Force ASP-1

Figure 5: Ground view of explosions  
in Marine ammunition  
storage point







Figure 6: Aerial photograph of Marine ammunition storage point



Figure 7: Aerial photograph of Air Force ammunition storage point. Revetment E-19 detonated, burying neighboring revetments E-18 and E-20. Explosion did not propagate.

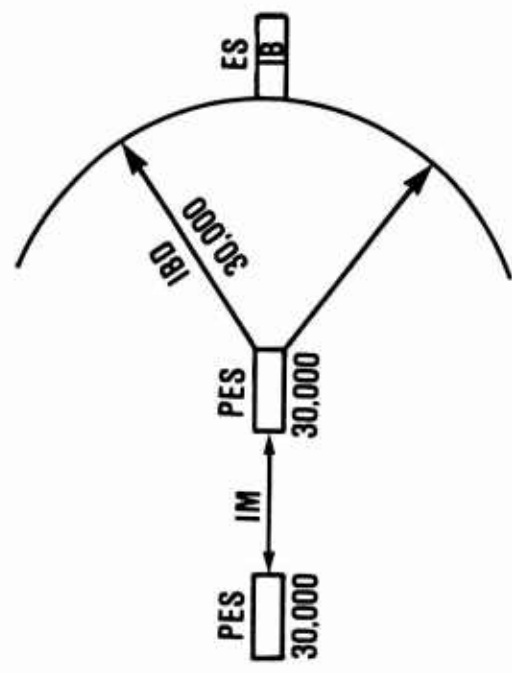
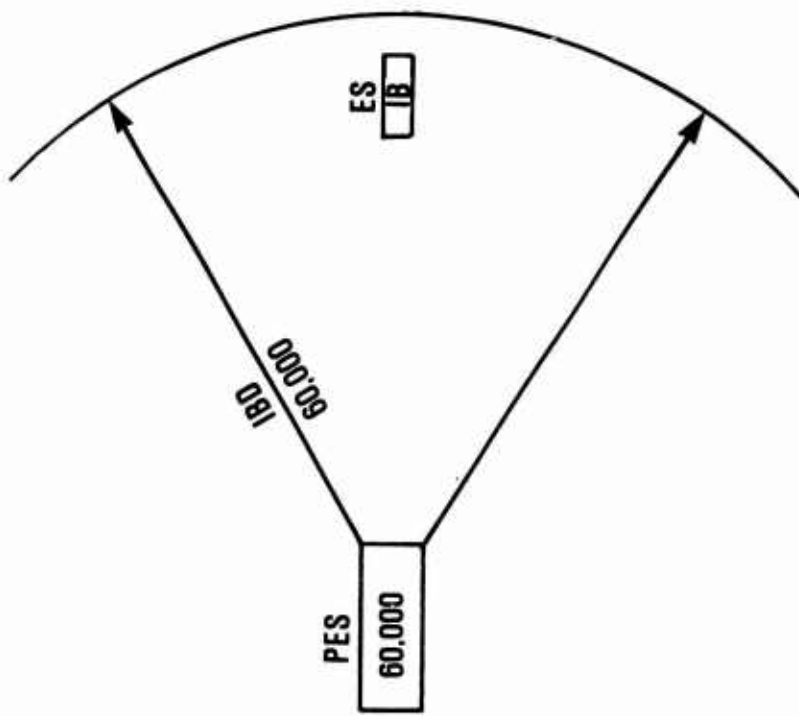

Figure 9

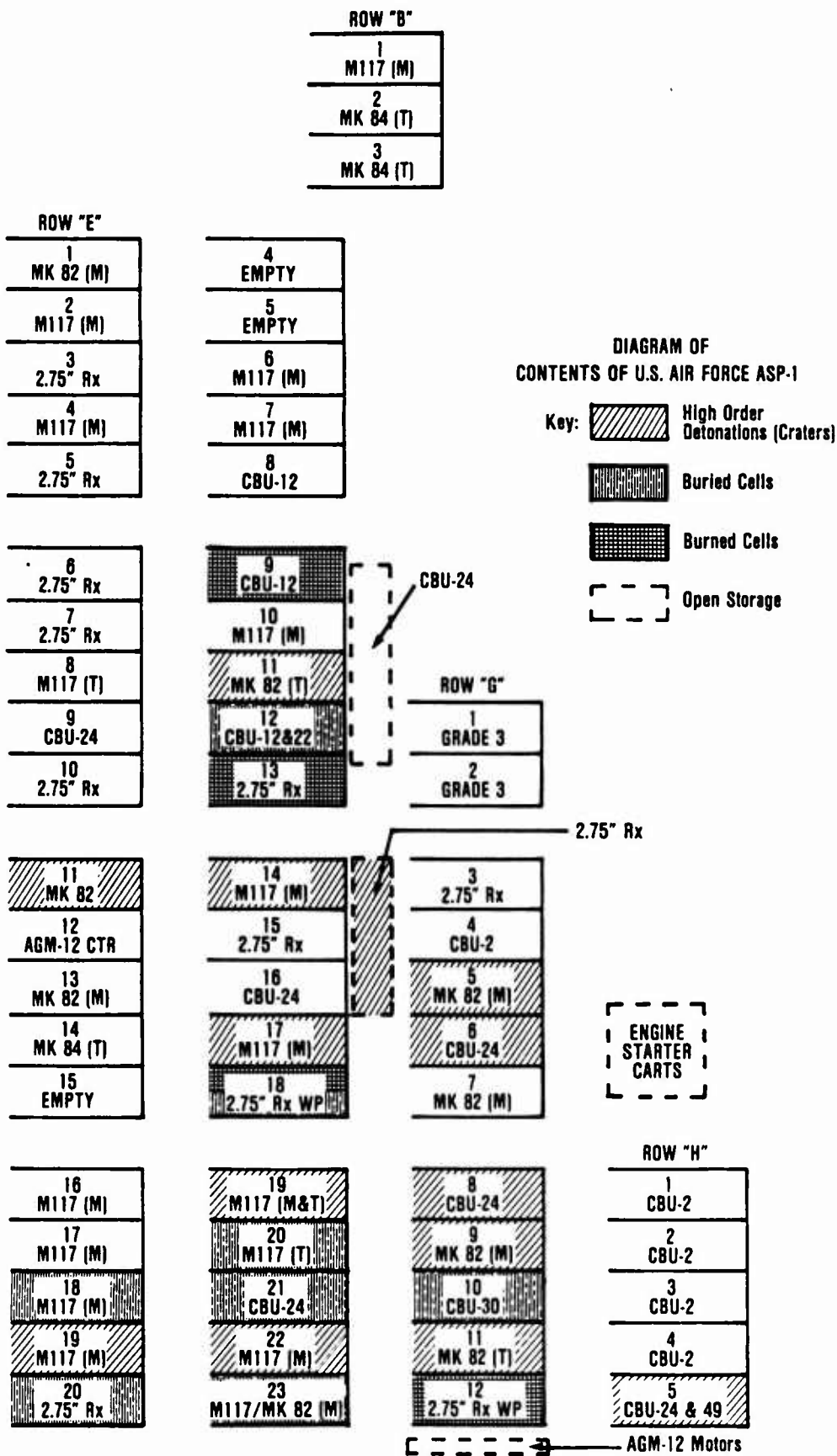

Figure 8  
1622

## **RISK ASSESSMENT**

- IDENTIFY PES
- IDENTIFY EXPOSED SITE
- USE  $D = K \times \text{NEW}^{1/3}$ 
  - CALCULATE REQUIRED SEPARATION DISTANCES/NET EXPLOSIVES WEIGHTS
  - CALCULATE PROBABLE DAMAGE TO ES

Figure 10

ELEMENT	DAMAGE	SIDE ON OVERPRESSURE
Aircraft	Control Surface or other minor damage	1.0-2.0
	Major repair	2.0-3.0
	Complete destruction	4-10
Glass windows, large and small	Shattering, occasional frame failure	0.5-1.0
	Severe frame failure	1.5-3.0
	Roof rafters cracked	0.5-1.5
Wood frame structures	Studs and sheathing cracked	1.0-3.0
	Collapse	over 5.0
	Corrugated aluminum/steel paneling moderately buckled/joints separated	0.5-1.0
Metal (Butler type) buildings	Severe buckling/some panels torn off	1.0-2.0
	Complete destruction of siding/interior destroyed	over 3.0
	Sever damage/shattering	1.0-2.0
Concrete block or brick wall, 8-12 inches (unreinforced)	Collapse	7.0-8.0
	Shattering	1.0-2.0
	Moderate cracking	3.0-4.0
Reinforced concrete walls	Severe spalling/wall displacement	6.0-8.0
	Concrete shelters, bare steel remains	10-14
	Complete destruction	14-20
Liquid storage tanks (unpressurized)	Slight damage	0.5-1.5
	Severe damage	3.0-4.0
	Collapse	8-10
Vehicles/trailers	Complete destruction	10-14
	Moderate damage	6-8
	Complete displacement	8-10
Heavy machinery (generators, compressors, etc)	Destruction	14-20
	Blown down	30
	Steel towers	

Figure 11