

COMPONENT PART NOTICE

THIS PAPER IS A COMPONENT PART OF THE FOLLOWING COMPILATION REPORT:

TITLE: Minutes of the Explosives Safety Seminar (22nd) Held in Anaheim,
California on 26-28 August 1986. Volume 1.

TO ORDER THE COMPLETE COMPILATION REPORT, USE AD-A181 274.

THE COMPONENT PART IS PROVIDED HERE TO ALLOW USERS ACCESS TO INDIVIDUALLY AUTHORED SECTIONS OF PROCEEDING, ANNALS, SYMPOSIA, ETC. HOWEVER, THE COMPONENT SHOULD BE CONSIDERED WITHIN THE CONTEXT OF THE OVERALL COMPILATION REPORT AND NOT AS A STAND-ALONE TECHNICAL REPORT.

THE FOLLOWING COMPONENT PART NUMBERS COMPRISE THE COMPILATION REPORT:

AD#: P005 302 thru P005 349 AD#: _____

AD#: _____ AD#: _____

AD#: _____ AD#: _____

Accession For	
NTIS GRA&I	<input checked="" type="checkbox"/>
DTIC TAB	<input type="checkbox"/>
Unannounced	<input type="checkbox"/>
Justification _____	
By _____	
Distribution/	
Availability Codes	
Dist	Avail and/or Special
A-1	

This document has been approved for public release and sale; its distribution is unlimited.

AD-P005 318

DEPARTMENT OF DEFENSE
TWENTY-SECOND EXPLOSIVE SAFETY SEMINAR
ANAHEIM, CALIFORNIA

EQUIPMENT SUPPORT SYSTEMS IN
BLAST RESISTANT STRUCTURES

BY FRANKLIN P. EPERT
BOOKER ASSOCIATES, INC.
ST. LOUIS, MISSOURI

ABSTRACT

One of the often overlooked elements in the design of a structure to resist the effects of an accidental detonation of high explosives is the mounting and support of the wide range mechanical and electrical equipment installed in the facility. This paper addresses the techniques that should be considered in the mounting of mechanical and electrical equipment and, in particular, will address specific designs which have been utilized in buildings with multiple bays where a detonation in one bay could affect an adjacent bay. In such a facility, the detonation of a high explosive material in one bay could cause injury to personnel and loss of the use of the adjacent bay in spite of the fact that the structure is designed to protect personnel and equipment in those adjacent bays.

INTRODUCTION

When a blast resistant structure is called upon to protect personnel from the effects of a nearby accidental detonation, these effects not only include excessive pressure, thermal effects, and fragmentation but also flying and falling objects from within the protected space due to the externally applied loading. Typical structures in which this situation might occur include control rooms, adjacent production bays, H.E. storage facilities, and similar types of structures.

CONSIDERATIONS

In determining the need for special considerations in equipment mounting, the first step involves the examination of the structure to establish the displacement that is likely to occur during an excursion of the structure caused by an adjacent or nearby detonation. For example, the reinforced concrete dividing wall between two explosive handling bays is in place to protect personnel on either side of the wall from the effects of explosion on the opposite site. In Figure I(a) the deflection of such a wall is shown. During the design of this wall based on the maximum credible incident on the opposite face, it can be determined what deflection is anticipated. On a typical wall the deflection may approach 4 inches at the center of the wall. This maximum deflection will occur in 25-30 milliseconds after the structure begins to deflect. The movement of the wall will very closely follow that shown in Figure I(b) where the velocity versus time history for the center of the wall is shown. The wall is initially at rest and is accelerated to some maximum velocity and brought to rest at a point in time corresponding to the time of maximum deflection. The challenge is to determine the maximum acceleration at which an object might dislodge from the wall and become a projectile. Once this

Maximum dislodging force is determined, a supporting system can be designed to withstand that force such that the object will be either held in place or the supporting system will fail at a level that would prevent the device from becoming a missile within the protected space.

Another consideration is that as the mounting location is moved from the center of the wall to the edge, the displacement and acceleration decreases to a theoretical zero at edges. This is shown in Figure II, where acceleration contours are plotted. Regardless of the type of mounting system proposed, it is beneficial to locate wall attachments as close to the edge as possible. The ultimate solution, of course, is to not mount any devices on a wall that is subject to deflection due to an adjacent bay detonation. Referring to the photograph, the wall at the far end of the room shown is such a wall. Note that there are minimum mechanical and electrical devices mounted on the wall.

In those instances where it is not possible to avoid mounting on a wall subject to deflection, the decision then is whether it is possible to design a mounting system to withstand the acceleration and forces developed in the supportive device or whether it might be better to develop an isolated mounting device to absorb those forces.

ALTERNATIVES

The concept of isolating the installed equipment from the structure can be effective and in many designs a simple method of achieving this can be determined. One approach to isolation would be to construct a frame system within a blast resistant structure which would be totally isolated from the walls and

roof which experience deformation. This, of course, would require additional space within the structure resulting in higher construction costs and increased square footage requirements for the facility. Simpler and less costly approaches are to utilize mounting methods and materials compatible with the expected acceleration and forces. The following mounting methods are presented as possible solutions; however, each individual case needs to be evaluated to determine the need for protective mounting and the level of protection desired.

Overhead Supports: Typical devices to be supported overhead include light fixtures and overhead cranes. In considering such installations, it is important to note that the supporting device must be able to support the equipment while it is in normal use and be able to respond to accelerations caused by deflection of the structure following an adjacent bay or exterior detonation. For overhead mounted equipment, the excursion of the structure can be either horizontal as in the case of an adjacent bay detonation or vertical if due to externally applied forces. A simple technique for mounting a lighting fixture, for example, is shown in Figure III. An explosion proof lighting fixture can weigh as much as 100 pounds; consequently, the mounting device, in this case, a bent plate, must be able to remain in its original shape while supporting the light fixture in order that the fixture performs its designed task. However, when subject to an acceleration force, the plate can be designed to experience plastic deformation such that the movement can be withstood and the fixture remains in place. Figure IV depicts a crane rail mount, again affixed to the ceiling of a structure. The sacrificial plate concept as shown can be designed such that the plate experiences plastic deformation at a loading in excess of the dead weight of the crane when fully loaded and in operation.

The bolts which extend through the crane supporting beam serve as a safety backup feature in the event the sacrificial plate fails due to fatigue should the structure experience several cycles of excursions due to the adjacent detonation. Figure V indicates alternating mounting methods for other ceiling hung equipment. The top method consists of springs which isolate the load from the structure and can be used where the load on the springs is more or less constant and movement of the device during operation is not a concern. The method shown in the lower half of the Figure utilizes the bent plate concept in which the load is held in a fixed position under normal operation and the plates would only deform in the event of an adjacent bay or exterior detonation causing the ceiling to deform.

Wall Hung Supports: Mounting equipment on walls which are subject to deformation following an adjacent bay detonation require somewhat different considerations. Figure VI shows a typical mounting for duct work, in this case installed on an angle projecting from the wall and held in place by a metal strap. The angle would need to be mounted to the wall with sufficient strength to remain in place during deformation of the wall with the strap installed in such a manner that the duct can move within the strap to a limit equal to the anticipated wall movement. In this way, since the duct is not otherwise connected to the angle, the angle can slide to the right as the wall deflects and the duct would only move due to the friction between the duct and the angle. Note that the space for movement is allowed on both sides of the duct since the wall will initially accelerate and then decelerate as it achieves maximum deflection. This phenomenon goes back to the velocity versus time curve that was originally shown in Figure I. The installation of lighter pieces of equipment such as conduit can

be accomplished as shown in Figure VII. In this particular case, the clamp and anchor bolt need to be designed with sufficient strength to hold the conduit in place. An important consideration is the gap as shown between the conduit wall and the concrete. Recalling again the curve shown in Figure I, there is initially a high acceleration rate as the wall begins to deform. This gap permits the wall to move sufficiently that the rate of acceleration has decreased and the conduit hanger then would be able to withstand the forces applied without also deforming to any great extent. The amount of space required and the strength of the supporting strap can be determined utilizing theoretical approaches. In the case of multiple conduits and pipe being mounted on unistrut, a different approach would be required. This is shown in Figure VIII. The weight of the system is such that a direct connection to the deflecting wall would not be desirable. The bent plate method again is applicable in that the bent plate can be designed to support the conduit/pipe system during normal operations but would provide the plastic deformation required to protect those systems in the event the wall begins to deflect.

The photograph shows lighting fixtures and overhead crane rails which have been installed utilizing a bent or sacrificial plate system in a facility where the ceiling of the room is subject to vertical movement due to an adjacent bay detonation.

SUMMARY

The purpose of this paper has been to present some ideas relating to installation of mechanical and electrical devices within blast resistant structures. As can be noted from the material presented, there remains to be a number of areas that need to be explored in greater depth before any general

solutions can be offered. It is important to recognize the need to install equipment in order that it not become hazardous to occupants of the protected space and each individual case needs to be considered on its own merits. Any comments or suggestions relating to this approach are welcome.

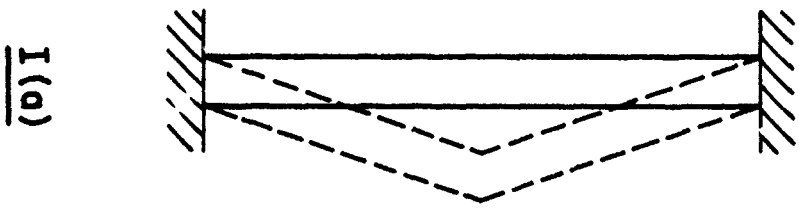

I(a)

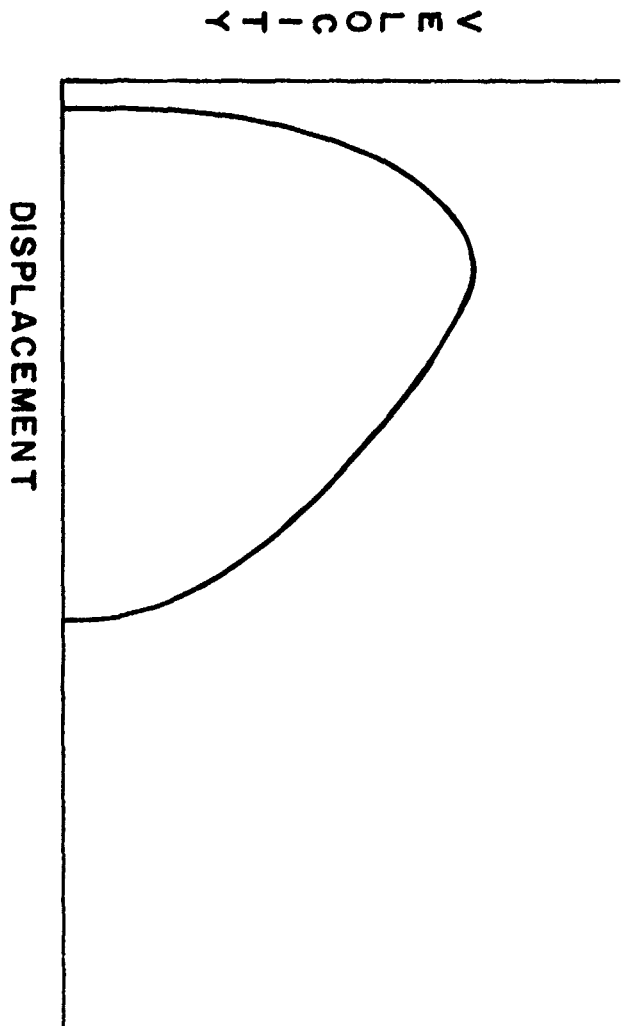

I(b)

FIGURE 1

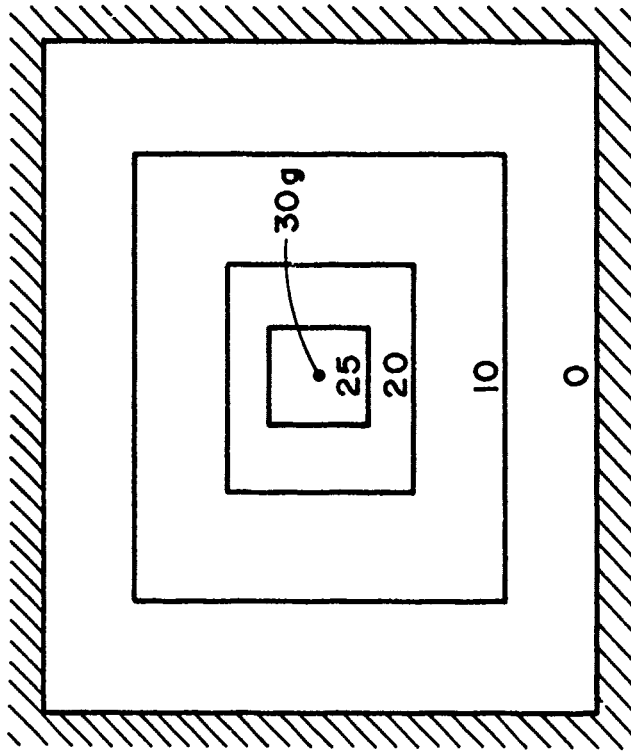

WALL ELEVATION
ACCELERATION CONTOURS

FIGURE II

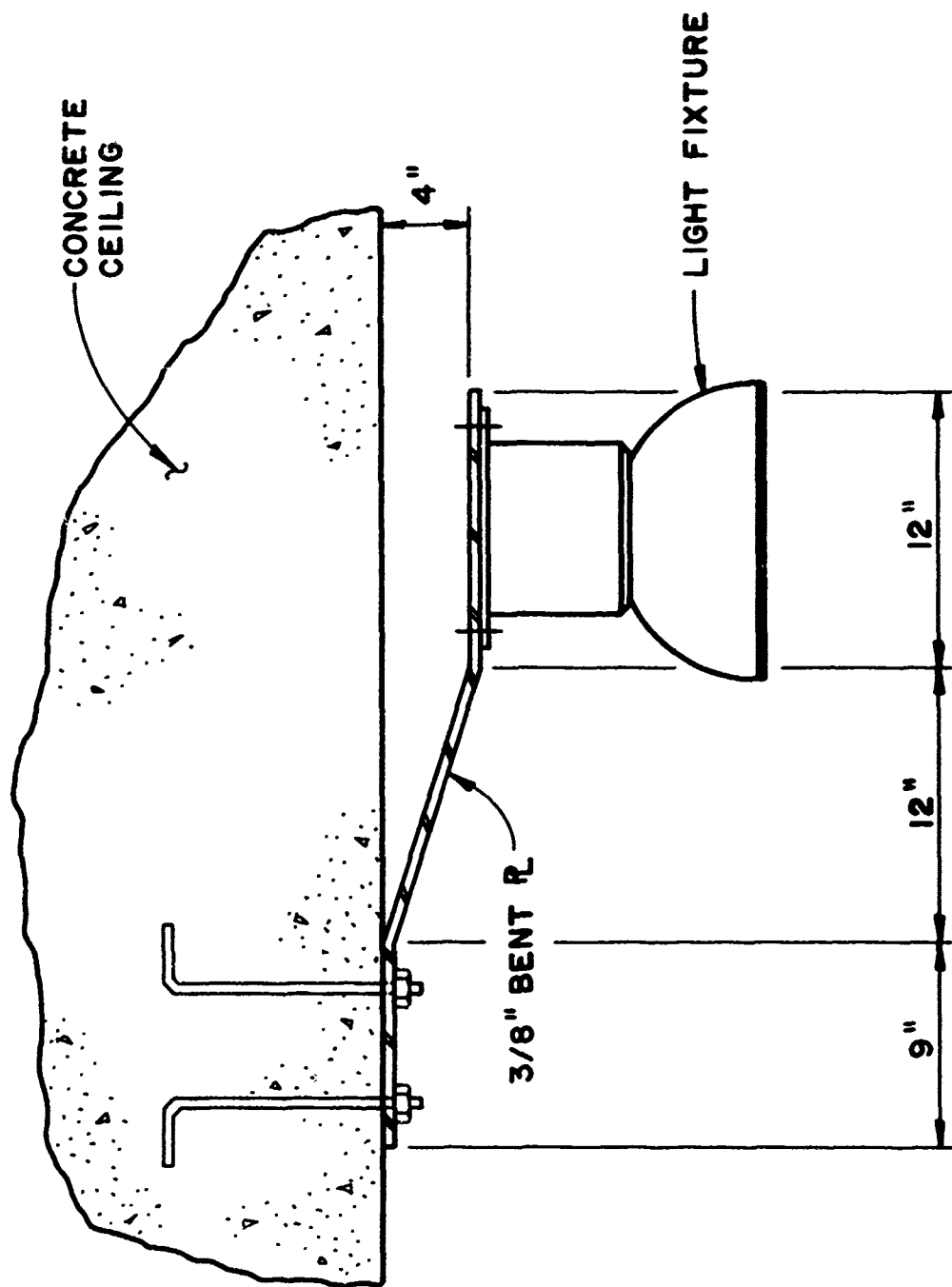

FIGURE III

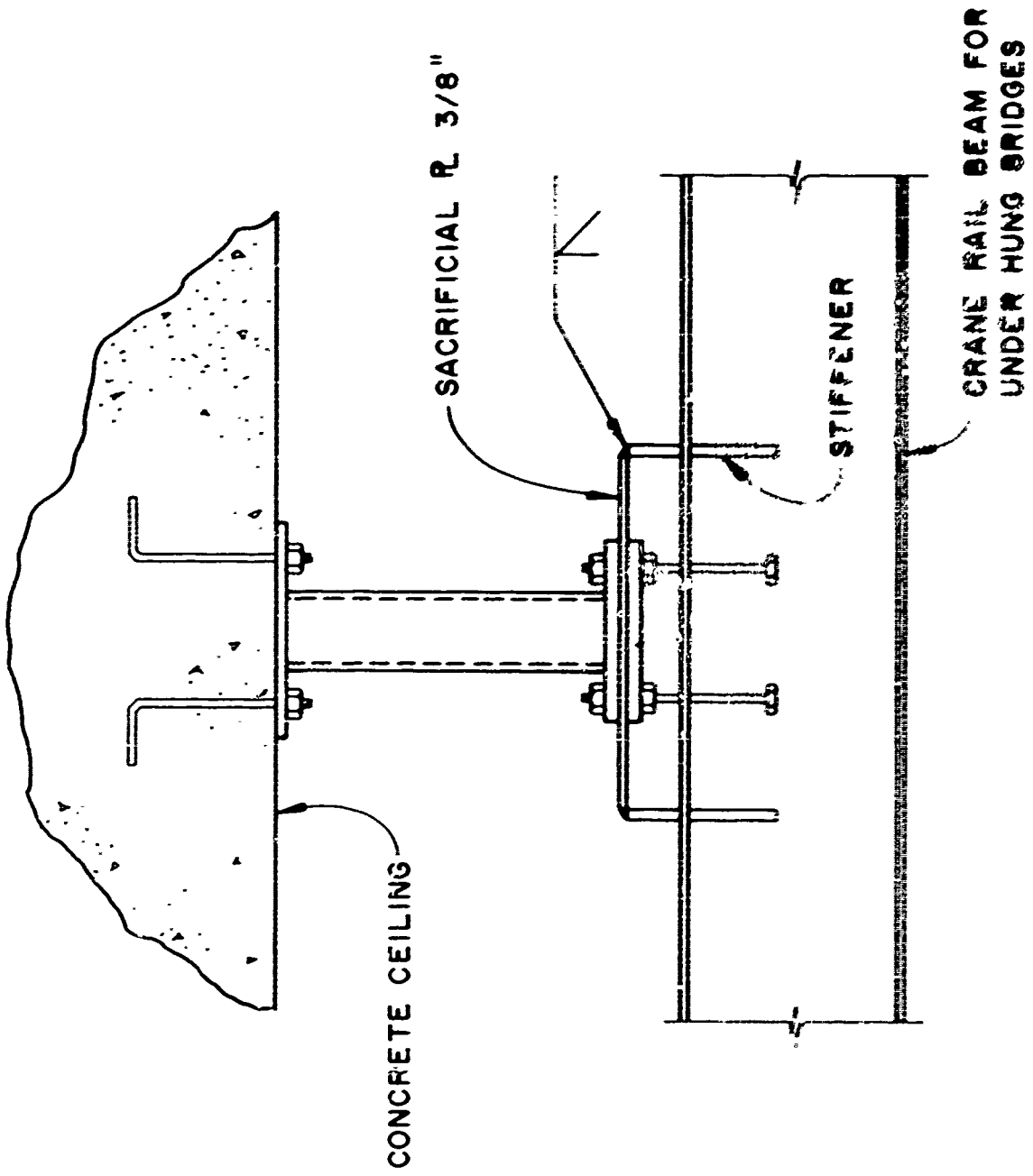

FIGURE IV

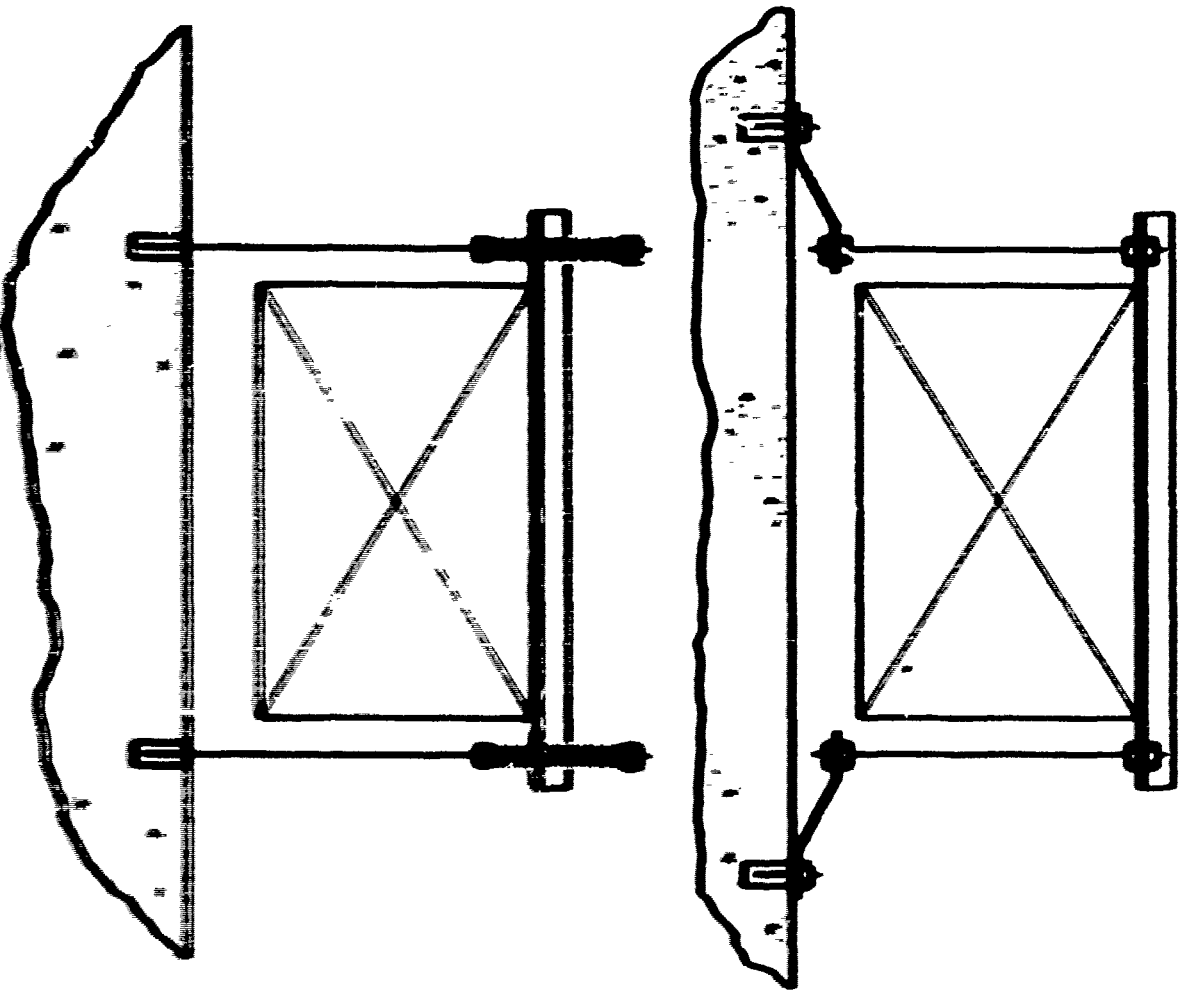

FIGURE V

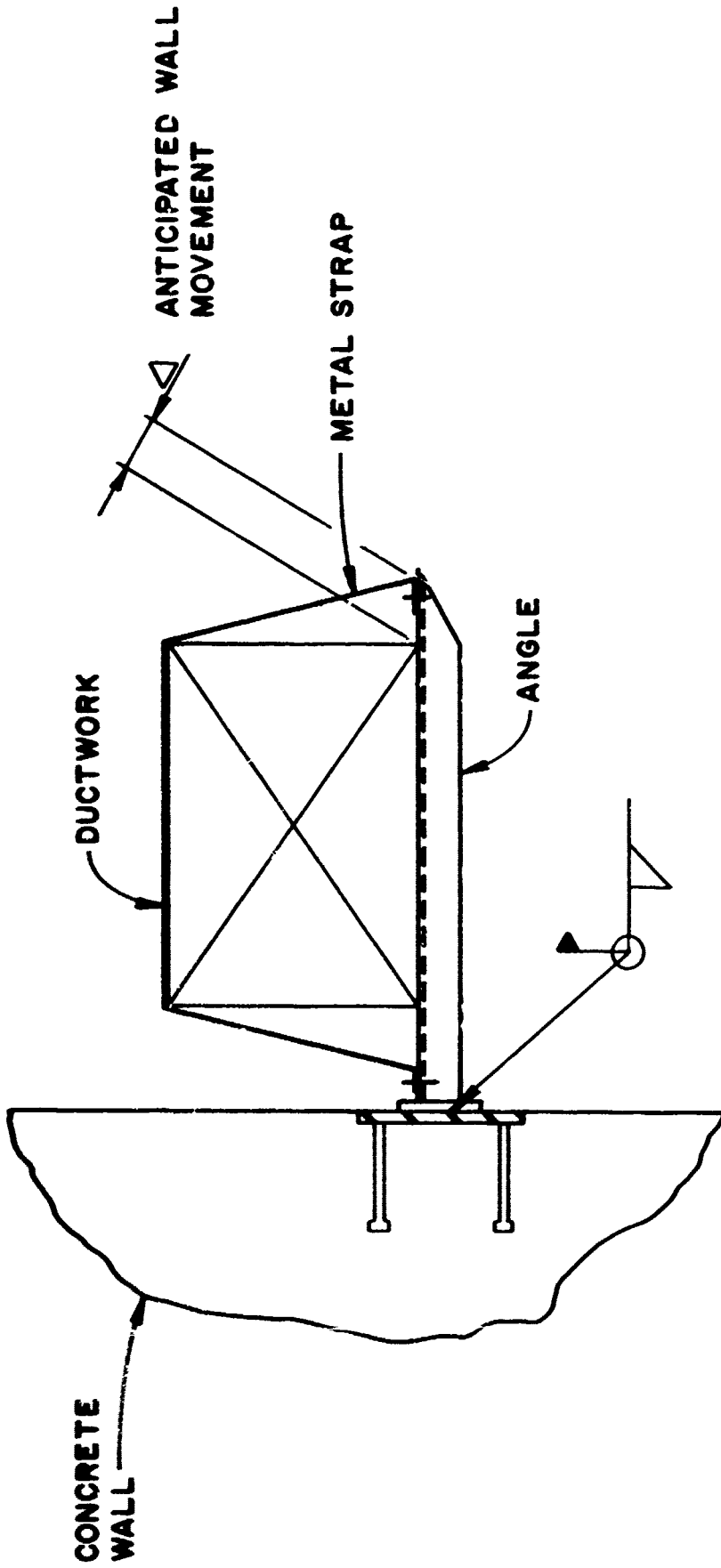

FIGURE VI

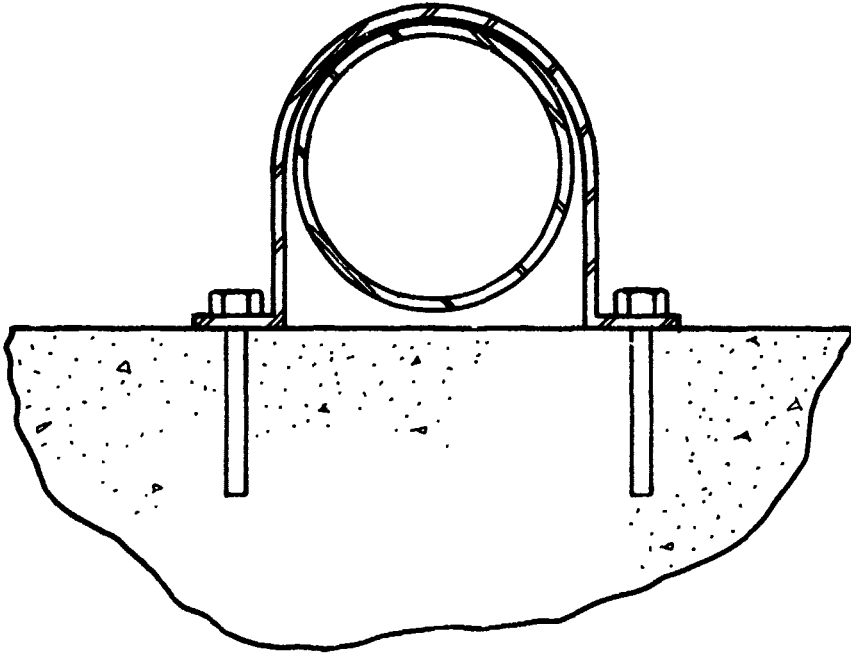

FIGURE VII

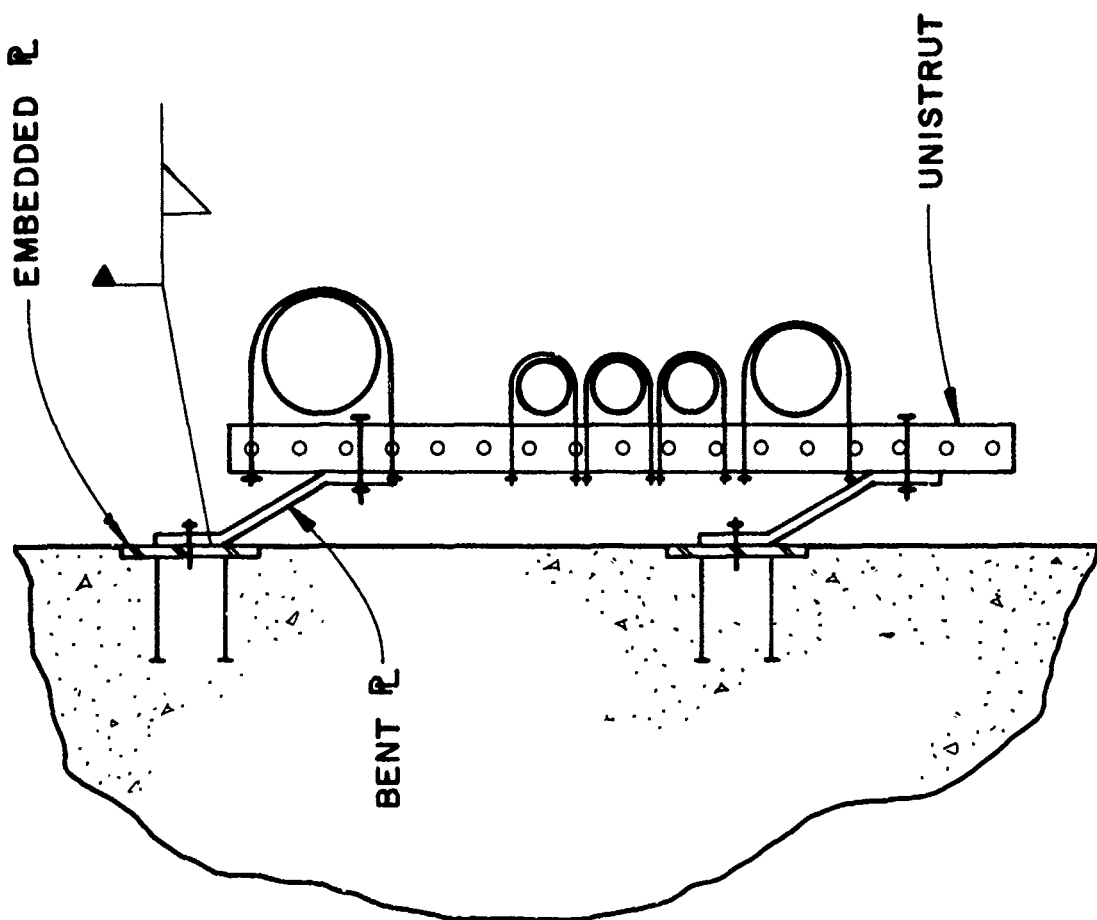

FIGURE VIII

