

COMPONENT PART NOTICE

THIS PAPER IS A COMPONENT PART OF THE FOLLOWING COMPILATION REPORT:

TITLE: Minutes of the Explosives Safety Seminar (21st) Held at Houston,
Texas on 28-30 August 1984. Volume 1.

TO ORDER THE COMPLETE COMPILATION REPORT, USE AD-A152 062

THE COMPONENT PART IS PROVIDED HERE TO ALLOW USERS ACCESS TO INDIVIDUALLY AUTHORED SECTIONS OF PROCEEDING, ANNALS, SYMPOSIA, ETC. HOWEVER, THE COMPONENT SHOULD BE CONSIDERED WITHIN THE CONTEXT OF THE OVERALL COMPILATION REPORT AND NOT AS A STAND-ALONE TECHNICAL REPORT.

THE FOLLOWING COMPONENT PART NUMBERS COMPRISE THE COMPILATION REPORT:

AD#: P004 821 thru P004 861 AD#: _____
 AD#: _____ AD#: _____
 AD#: _____ AD#: _____

Accession For	
NTIS GRA&I	<input checked="" type="checkbox"/>
DTIC TAB	<input type="checkbox"/>
Unannounced	<input type="checkbox"/>
Justification _____	
By _____	
Distribution/	
Availability Codes	
Dist	Avail and/or Special
A-1	

This document has been approved for public release and sale; its distribution is unlimited.

AD-P004 825

DESIGN CRITERIA AND PRELIMINARY ACCEPTANCE TEST
SPECIFICATIONS FOR BLAST RESISTANT WINDOWS

By

Gerald E. Meyers
Research Structural Engineer
Naval Civil Engineering Laboratory
Port Hueneme, CA 93043

ABSTRACT

↳ Preliminary design criteria for blast resistant windows exposed to blast overpressures up to 25 psi are recommended. Design procedures and design curves for fully tempered glass are presented and parametrized according to glass thickness, glass dimensions, glass aspect ratio, peak blast overpressures, and effective blast duration. Curves for annealed glass are also presented for the purpose of analyzing the safety of existing structures. Design criteria for frames and a test certification procedure are also discussed. Additionally, design examples are presented. ↗

1. INTRODUCTION

Historical records of explosion effects demonstrate that airborne glass fragments from failed windows are a major cause of injuries from accidental explosions. This risk to life is heightened in modern facilities, which often have large areas of glass for aesthetic reasons.

Guidelines are presented for both the design, evaluation, and certification of windows to safely survive a prescribed blast environment described by a triangular-shaped pressure-time curve. Window designs using tempered glass based on these guidelines can be expected to provide a probability of failure at least equivalent to that provided by current safety standards for safely resisting wind loads.

The guidelines, which apply for peak blast overpressures less than about 25 psi, are presented in the form of load criteria for the design of both the glass panes and framing system for the window. The criteria account for both bending and membrane stresses and their effect on maximum principal stresses and the nonlinear behavior of glass panes. The criteria cover a broad range of design parameters for rectangular-shaped glass panes: a pane aspect ratio $1.00 \leq a/b \leq 2.00$, pane area $1.0 \leq ab \leq 25 \text{ ft}^2$, and nominal glass thickness $1/8 \leq t \leq 1/2 \text{ inch}$. Most of the criteria are for blast resistant windows with fully heat-treated, tempered glass. However, criteria are also presented for annealed glass in order to assess the safety of existing windows that were not designed to resist blast overpressures.

2. DESIGN CRITERIA FOR GLAZING

2.1 Glazing Materials

The design criteria cover two types of glass: annealed glass and fully tempered glass. Both glazings are required to meet the requirements of Federal Specifications DD-G-1403B and DD-G-451d. Tempered glass is also required to meet the requirements of ANSI Z97.1-1975.

Annealed glass is the most common form of glass available today. Depending upon manufacturing techniques, it is also known as plate, float or sheet glass. During manufacture, it is cooled slowly. The process results in very little, if any, residual compressive surface stress. Consequently, annealed glass is of relatively low strength when compared to tempered glass. Furthermore, it has large variations in strength and fractures into dagger-shaped, razor-sharp fragments. For these reasons, annealed glass is not recommended for use in blast resistant windows. It is included in the design criteria only for safety analysis of existing facilities.

Heat-treated, tempered glass is the most readily available tempered glass on the market. It is manufactured from annealed glass by heating to a high uniform temperature and then applying controlled rapid cooling. As the internal temperature profile relaxes towards uniformity, internal stresses are created. The outer layers, which cool and contract first, are set in compression, while internal layers are set in tension. As it is rare for flaws, which act as stress magnifiers, to exist in the interior of tempered glass sheets, the internal tensile stress is of relatively minimal consequence. As failure originates from tensile stresses exciting surface flaws in the glass, precompression permits a larger load to be carried before the net tensile strength of the tempered glass pane is exceeded. Tempered glass is typically four to five times stronger than annealed glass.

The fracture characteristics of tempered glass are superior to annealed glass. Due to the high strain energy stored by the prestress, tempered glass will eventually fracture into small cube-shaped fragments instead of the razor-sharp and dagger-shaped fragments associated with

fracture of annealed glass. Breakage patterns of side and rear windows in American automobiles are a good example of the failure mode of heat-treated tempered glass.

Semi-tempered glass is often marketed as safety or heat-treated glass. However, it exhibits neither the dicing characteristic upon breakage nor the higher tensile strength associated with fully tempered glass. Semi-tempered glass is not recommended for blast resistant windows unless it is laminated or backed by a fragment retention film.

Another common glazing material is wire glass, annealed glass with an embedded layer of wire mesh. Wire glass has the fracture characteristics of annealed glass and although the wire binds fragments, it presents metal fragments as an additional hazard. Wire glass is not recommended for blast resistant windows.

The design of blast resistant windows is restricted to heat-treated fully-tempered glass meeting both Federal Specification DD-G-1403B and ANSI Z97.1-1975. Tempered glass meeting only DD-G-1403B may possess a surface precompression of only 10,000 psi. At this level of precompression, the fracture pattern is similar to annealed and semi-tempered glass. Tempered glass meeting ANSI Z97.1-1975 has a higher surface precompression level and tensile strength which improves the capacity of blast resistant windows. Additionally, failure results in smaller cubical-shaped fragments. To assure reliable performance of blast resistant glazing, it is required that heat-treated tempered glass fully conform to ANSI Z97.1-1975.

Although heat-treated tempered glass exhibits the safest failure mode, failure under blast loading still presents a significant health hazard. Results from blast tests reveal that upon fracture, tempered glass fragments may be propelled in cohesive clumps that only fragment upon impact into smaller rock-salt type fragments. Even if the tempered glass breaks up initially into small fragments, the blast pressure will propel the fragments at a high velocity which constitutes a hazard. Adding fragment retention film (discussed in Section 2.5) to the inside face of heat-treated tempered glass will significantly improve safety.

2.2 Design Stresses

The design stress is the maximum principal tensile stress allowed for the glazing. The design stress was derived for a prescribed probability of failure, using a statistical failure prediction model under development by the ASTM. Thus, failure of the glazing is assumed to occur when the maximum principal tensile stress exceeds a design stress associated with a prescribed probability of failure. The model accounts for the area of glazing (as it effects the size, number and distribution of surface flaws), stress intensity duration, thickness and aspect ratio of glazing (as it affects the ratio of maximum to minimum principle stresses in the glazing), degree of glass temper (as it affects the precompression stress in the glazing), strength degradation due to exposure, and the maximum probability of failure required of the glazing. For the full range of design parameters ($1.0 \leq ab \leq 25 \text{ ft}^2$, $1.00 \leq a/b \leq 2.00$ and $1/8 \leq t \leq 1/2$ inches), and a stress intensity duration of 1,000 msec, the model predicted a design stress for tempered glass ranging between 16,950 and 20,270 psi based on a probability of failure $P(F) \leq 0.001$. Because analysis indicates that significant stress intensity durations are less than 1,000 msec, even for pressure durations of 1,000 msec, a design stress equal to 17,000 psi was selected for tempered glass. The model also predicted an allowable stress for annealed glass ranging between 3,990 and 6,039 psi, based on $P(F) \leq 0.008$, which is conventional for annealed glass. Based on these results, an allowable stress of 4,000 psi was selected for the analysis of annealed glass.

These design stresses for blast resistant glazing are higher than those commonly used in the design for one-minute wind loads. However, these higher design stresses are justified on the basis of the relatively short stress intensity duration (always considerably less than one second) produced by blast loads.

2.3 Dynamic Response to Blast Load.

An analytical model was used to predict the blast load capacity of annealed and tempered glazings. Characteristic parameters of the model are illustrated in Figure 1.

The glazing is a rectangular glass plate having a long dimension, a , short dimension, b , thickness, t , poisson ratio, $\nu = 0.22$, and elastic modulus, $E = 10,000,000$ psi. The plate is simply supported along all four edges, with no in-plane and rotational restraints at the edges. The relative bending stiffness of the support members is assumed to be infinite relative to the pane. The failure or design stress, f_u , was assumed to be 17,000 psi for tempered glass and 4,000 psi for annealed glass.

The blast pressure loading is described by a peak triangular-shaped pressure-time curve as shown in Figure 1b. The blast pressure rises instantaneously to a peak blast pressure, B , and then decays with a blast pressure duration, T . The pressure is uniformly distributed over the surface of the plate and applied normal to the plate.

The resistance function (static uniform load, r , versus center deflection, X) for the plate accounts for both bending and membrane stresses. The effects of membrane stresses produce nonlinear stiffening of the resistance function as illustrated in Figure 1c. The failure deflection, X_u , is defined as the center deflection where the maximum principle tensile stress at any point in the glass first reaches the design stress, f_u .

The model used a single degree of freedom system to simulate the dynamic response of the plate, as shown in Figure 1d. Damping of the window pane is assumed to be 5% of critical damping. The applied load, $P(t)$, is shown in Figure 1b. The resistance function, $r(x)$, is shown in Figure 1c. Given the design parameters for the glazing, the design or failure stress, f_u , and the blast load duration, T , the model calculated the peak blast pressure, B , required to fail the glazing by exceeding the prescribed probability of failure, $P(F)$. The model also assumed failure to occur if the center deflection exceeded ten times the glazing thickness. This restricts solutions to the valid range of the Von Karmen plate equations used to develop the resistance function for the glazing.

2.4 Design Charts

Charts are presented in Figures 2 to 16 for both the design and evaluation of glazing to safely survive a prescribed blast loading. The charts were developed using the analytical model described in Section 2.3. The charts relate the peak blast pressure capacity, B , of both tempered and annealed glazing to all combinations of the following design parameters: $a/b = 1.00, 1.25, 1.50, 1.75$ and 2.00 ; $1.00 \leq ab \leq 25 \text{ ft}^2$; $12 \leq b \leq 60$ inches; $2 \leq T \leq 1,000$ msec; and $t = 1/8, 3/16, 1/4, 3/8$ and $1/2$ inch (nominal) for tempered glass and $t = 1/8$ and $1/4$ inch (nominal) for annealed glass.

Each chart has a series of curves. Each curve corresponds to the value of b (short dimension of pane) shown to the right of the curve. Adjacent to each posted value of b is the value of B (peak blast pressure capacity) corresponding to $T = 1,000$ msec. The posted value of B is intended to reduce errors when interpolating between curves.

Figures 2 to 11 apply for heat-treated tempered glass meeting Federal Specification DD-G-1403B and ANSI Z97.1-1975. The value of B is the peak blast capacity of the glazing based on failure defined as $f_u = 17,000$ psi. This value corresponds to a probability of failure, $P(F) \leq 0.001$.

Figures 12 to 16 apply for annealed (float, plate or sheet) glass. Due to the variation in the mechanical properties and fragment hazard of annealed glass, Figures 12 to 16 are not intended for design, but for safety evaluation of existing glazing. The value of B is the peak blast pressure capacity of the glazing based on $f_u = 4,000$ psi. This value corresponds to $P(F) \leq 0.008$, the common architectural standard for annealed glass.

The charts are based on the minimum thickness of fabricated glass allowed by Federal Specification DD-G-451d. However, the nominal thickness should always be used in conjunction with the charts, i.e., $t = 1/8$ inch instead of the possible minimum thickness of 0.115 inch.

In a few cases, the charts show a pane to be slightly stronger than the preceding smaller size. This anomaly stems from dynamic effects and the migration of maximum principal stresses from the center to the

corner region of the window pane. In such cases, interpolation should be between the two curves that bound the desired value.

2.5 Fragment Retention Film

Many injuries in explosions are caused by glass fragments propelled by the blast wave when a window is shattered. Commercial products have been developed which offer a relatively inexpensive method to improve the shatter resistance of window glass and decrease the energy and destructive capability of glass fragments. The product is a clear plastic (polyester) film which is glued to the inside surface of window panes. The film is used primarily for retrofitting previously installed windows. Typical films are about 0.002 to 0.004 inch thick polyester with a self-adhesive face. The film is often commercially referred to as shatter resistant film, safety film, or security film.

The film increases safety by providing a strong plastic type backing. The film will hold the glass in position even though the glass is shattered. If a complete pane of film reinforced glass is blown away from its frame by a higher than design blast wave, it will travel as a single piece while adhering to the film. In this configuration, tests indicate that it will travel a shorter distance and the individual fragments will be less hazardous because of the shielding effect of the film. If a strong structural member or crossbar, which can be decorative, is secured across the opening, the glass will tend to wrap around the crossbar in a manner similar to a wet blanket and will be prevented from being propelled across a room. Additionally, if a projectile strikes the film reinforced glass with sufficient force to pass through it, the glass immediately around the hole will ordinarily adhere to the film. The result is that any fragments broken free by the impact will be few in number and lower in energy content. Results from explosives tests demonstrate that the film is highly effective in reducing the number of airborne glass fragments.

There are additional benefits from fragment retention film. The film can be tinted to improve the heat balance of the structure. Also, the film affords benefits in terms of physical security. Additionally,

the film also protects the inner tensile surface of the glazing from scratches and humidity, thus reducing strength degradation of the glazing with time. Finally, in the event of a multiple blast explosion where the glass will be progressively weakened by the effects of ceramic fatigue, fragment retention film can provide a critical factor of safety.

3. DESIGN CRITERIA FOR FRAME

3.1 Sealants and Gaskets

The sealant and gasket design should be consistent with industry standards and also account for special requirements for blast resistant windows. The gasket should be continuous around the perimeter of the glass pane and its stiffness should be at least 10,000 psi (pounds/linear inch of frame/inch of gasket deflection). Analysis indicates that the employment of a gasket stiffness below 10,000 psi will increase the failure rate of the window pane. The gasket should provide adequate grip as the glass pane flexes under the applied blast loading.

3.2 Frame Loads

The window frame must develop the static design strength of the glass pane, r_u , given in Table 1. Otherwise, the design is inconsistent with frame assumptions and the peak blast pressure capacity of the window pane predicted from Figures 2 to 16 will produce a failure rate in excess of the prescribed failure rate. This results because frame deflections induce higher principal tensile stresses in the pane, thus reducing the strain energy capacity available to safely resist the blast loading.

In addition to the load transferred to the frame by the glass, frame members must also resist a uniform line load, r_u , applied to all exposed members. Until criteria are developed to account for the interaction of the frame and glass panes, the frame, mullions, fasteners, and gaskets should satisfy the following design criteria:

1. Deflection: No frame member should have a relative displacement exceeding $1/264$ of its span or $1/8$ inch, whichever is less.
2. Stress: The maximum stress in any member should not exceed $f_y/1.65$, where f_y = yield stress of the members material.
3. Fasteners: The maximum stress in any fastener should not exceed $f_y/2.00$.
4. Gaskets: The stiffness of gaskets should be at least 10,000 psi (pounds/linear inch of frame/inch of gasket deflection).

The design loads for the glazing are based on large deflection theory, but the resulting transferred design loads for the frame are based on an approximate solution of small deflection theory for laterally loaded plates. Analysis indicates this approach to be considerably simpler and more conservative than using the frame loading based exclusively on large deflection membrane behavior, characteristic of window panes. According to the assumed plate theory, the design load, r_u , produces a line shear, V_x , applied by the long side, a , of the pane equal to:

$$V_x = C_x r_u b \sin (\pi x/a) \quad (1)$$

The design load, r_u , produces a line shear, V_y , applied by the short side, b , of the pane equal to:

$$V_y = C_y r_u b \sin (\pi y/b) \quad (2)$$

The design load, r_u , produces a corner concentrated load, R , tending to uplift the corners of the window pane equal to:

$$R = -C_R r_u b^2 \quad (3)$$

Distribution of these forces, as loads acting on the window frame, is shown in Figure 17. Table 2 presents the design coefficients, C_x , C_y , and C_R for practical aspect ratios of the window pane. Linear interpolation can be used for aspect ratios not presented. The loads given by Equations 1, 2, 3 and the load caused by a uniform line load, r_u , should be used to check the frame mullions and fasteners for compliance with the deflection and stress criteria stated above. It is important to note that the design load for mullions is twice the load given by Equations 1 to 3, in order to account for effects of two panes being supported by a common mullion.

3.3 Rebound Stresses

Under a short duration blast load, the window will rebound with a negative (outward) deflection. The stresses produced by the negative deflection must be safely resisted by the window while positive pressures act on the window. Otherwise, the window which safely resists stresses induced by positive (inward) displacements will later fail in rebound while positive pressure still acts. This will propel glass fragments into the interior of the structure. However, if the window fails in rebound during the negative (suction) phase of the blast loading, glass fragments will be drawn away from the structure.

Rebound criteria are currently not available for predicting the equivalent static uniform negative load (resistance), r_u^- , that the window must safely resist for various blast load durations. However, analysis indicates that for $T \geq 400$ msec, significant rebound does not occur during the positive blast pressure phase for the range of design parameters given in Figures 2 to 16. Therefore, rebound can be neglected as a design consideration for $T \geq 400$ msec. For $T < 400$ msec, it is recommended that the rebound charts in Volume 3 of NAVFAC P-397 be used to estimate r_u^- .

4. CERTIFICATION TESTS

Certification tests of the entire window assembly are required unless analysis demonstrates that the window design is consistent with assumptions used to develop the design criteria presented in Figures 2 to 16. The certification tests consist of applying static uniform loads on at least two sample window assemblies until failure occurs in either the tempered glass or frame. Although at least two static uniform load tests until sample failure are required, the acceptance criteria presented below encourages a larger number of test samples. The number of samples, beyond two, is left up to the vendor. Results from all tests shall be recorded in the calculations. All testing shall be performed by an independent and certified testing laboratory.

A probability of failure under testing of less than 0.025 with a confidence level of 90% is considered sufficient proof for acceptance. This should substantiate a design probability of failure, $P(F)$, under the design blast load of 0.001.

4.1 Test Procedure - Window Assembly Test

The test windows (glass panes plus support frames) shall be identical in type, size, sealant, and construction to those furnished by the window manufacturer. The frame assembly in the test setup shall be secured by boundary conditions that simulate the adjoining walls. Using either a vacuum or a liquid-filled bladder, an increasing uniform load shall be applied to the entire window assembly (glass and frame) until failure occurs in either the glass or frame. Failure shall be defined as either breaking of glass or loss of frame resistance. The failure load, \hat{r} , shall be recorded to three significant figures. The load should be applied at a rate of $0.5 r_u$ per minute which corresponds to approximately one minute of significant tensile stress duration until failure. Table 1 presents the static ultimate resistance, r_u , for new tempered glass correlated with a probability of failure, $P(F)$, = 0.001 and a static load duration of 1 minute. Because the effects of utilizing

new glass and a longer duration tend to offset each other, r_u also closely corresponds to the equivalent static load induced by the design blast.

4.2 Acceptance Criteria

The window assembly (frame and glazing) are considered acceptable when the arithmetic mean of all the samples tested, \bar{r} , is such that:

$$\bar{r} \geq r_u + s \alpha \quad (4)$$

where: r_u = ultimate static load capacity of the glass pane

s = sample standard deviation

α = acceptance coefficient

For n test samples, \bar{r} is defined as:

$$\bar{r} = \frac{\sum_{i=1}^n \hat{r}_i}{n} \quad (5)$$

where \hat{r}_i is the recorded failure load of the i^{th} test sample. The standard sample deviation, s , is defined as:

$$s = \sqrt{\frac{\sum_{i=1}^n (\hat{r}_i - \bar{r})^2}{(n - 1)}} \quad (6)$$

Convenience in calculation often can be obtained by employing an alternative but equal form of Equation 6.

$$s = \sqrt{\frac{\sum_{i=1}^n \hat{r}_i^2 - \left(\frac{\sum_{i=1}^n \hat{r}_i}{n} \right)^2}{(n - 1)}} \quad (7)$$

The minimum value of the sample standard deviation, s , permitted to be employed in Equation 4 is:

$$s_{\min} = 0.145 r_u \quad (8)$$

This assures a sample standard deviation no better than ideal tempered glass in ideal frames.

The acceptance coefficient, α , is tabulated in Table 3 for the number of samples, n , tested.

As an aid to the tester, the following informational equation is presented to aid in determining if additional test samples are justified. If:

$$\bar{r} \leq r_u + s \beta \quad (9)$$

then with 90% confidence, the design will not prove to be adequate with additional testing. The frame should be redesigned or thicker tempered glass used. The rejection coefficient, β , is obtained from Table 3.

If the glass assembly is upgraded with thicker tempered glass than required by the design charts (Figures 2 through 12) to resist a design blast load, it is not required to develop the higher ultimate static load capacity of the thicker glass. Instead, a static load equal to twice the design peak blast overpressure, B , shall be resisted by the window assembly. Thus the window assembly with thicker than required tempered glass shall be acceptable when:

$$\bar{r} \geq 2 B + s \alpha \quad (10)$$

If Equation 10 is not satisfied, and:

$$\bar{r} \leq 2 B + s \beta \quad (11)$$

then with 90% confidence continued testing will not raise the arithmetic mean of the failure load of the window assembly, \bar{r} , to the point of acceptance.

4.3 Rebound Tests

The window that passes the window assembly test is an acceptable design if the window assembly design is symmetrical about the plane of the glass or if the design blast load duration, T , exceeds 400 msec. Otherwise, the window design must pass a rebound load test to prove that the window assembly can develop the necessary strength to resist failure during the rebound phase of response. The rebound tests shall be conducted using a procedure similar to the window assembly tests, except r_u^- shall be substituted for r_u in Equations 4, 8 and 9 and the uniform load shall be applied on the inside surface of the window assembly. The loading rate shall be $0.5 r_u$ per minute.

4.4 Installation Inspection

A survey of past glazing failures indicates that improper installation of setting blocks, gaskets or lateral shims, or poor edge bite is a significant cause of failure because of the resultant unconservative support conditions. In order to prevent premature glass failure, a strenuous quality control program is required.

5. SAMPLE PROBLEMS

The following examples demonstrate the application of the design criteria in the design and evaluation of windows to safely survive blast overpressures from explosions.

5.1 Problem 1 -- Design of Tempered Glass Panes

Given: A nonoperable window having a single pane of glass. Glazing: heat-treated tempered glass meeting Federal Specification DDG-G-1403B and ANSI Z97.1-1975. Dimensions of pane: $a = 54$ in., $b = 36$ in. Blast loading: $B = 5.0$ psi, $T = 500$ msec.

Find: Minimum thickness of glazing required for $P(F) \leq 0.001$.

Solution: Step 1: Tabulate the design parameters needed to enter Figure 2 to 16.

Glazing = tempered glass

$$a/b = 54/36 = 1.50$$

$$b = 36 \text{ in.}$$

$$B = 5.0 \text{ psi}$$

$$T = 500 \text{ msec}$$

Step 2: Enter Figures 2 to 16 with the design parameters from Step 1 and find the minimum glazing thickness.

Figures 6 and 7 apply for the given design parameters. Enter Figure 6 and find the minimum glazing thickness required for $B = 5.0 \text{ psi}$ and $T = 500 \text{ msec}$ is:

$$t = 3/8 \text{ in.}$$

ANS

The asterisk adjacent to $b = 36$ inches indicates that the strength of the glazing is limited by principle stresses in corner regions of the pane.

5.2 Problem 2 -- Safety Evaluation of Existing Windows

Given: Multi-pane windows in an existing building. Dimensions of each pane: $a = 36 \text{ in.}$, $b = 36 \text{ in.}$ Glazing: float glass. Glazing thickness: $t = 1/4 \text{ in.}$ nominal. Blast loading: $B = 0.60 \text{ psi}$, $T = 100 \text{ msec}$.

Find: Safety of windows, based on $P(F) \leq 0.008$

Solution: Step 1: Tabulate the design parameters needed to enter Figures 2 to 16.

Glazing = annealed glass

$$a/b = 36/36 = 1.00$$

$$B = 0.60 \text{ psi}$$

$$T = 100 \text{ msec}$$

$$t = 1/4 \text{ in.}$$

Step 2: Enter Figures 12 to 16 with the design parameters from Step 1 and find the peak blast pressure capacity.

From Figure 12, the peak blast pressure capacity of the glazing is:

$$B = 0.53 \text{ psi}$$

Step 3: Determine the safety of the glazing.

The applied peak blast pressure, $B = 0.60 \text{ psi}$, exceeds the capacity, $B = 0.53 \text{ psi}$. Therefore, the glazing will fail at an average rate exceeding eight per thousand panes.

ANS

5.3 Problem 3 -- Design Loads for Window Frame

Given: A nonoperable window has a single pane of glass. Glazing: heat-treated tempered glass meeting Federal Specification DD-G-1403B and ANSI Z97.1-1975. Dimensions of the pane: $a = 50 \text{ in.}$, $b = 40 \text{ in.}$ Blast loading: $B = 1.3 \text{ psi}$, $T = 1,000 \text{ msec}$.

Find: Thickness of glazing required for $P(F) \leq 0.001$ and design loading for window frame.

Solution: Step 1: Tabulate the design parameters needed to enter Figures 2 to 16.

Glazing = tempered glass

$$a/b = 50/40 = 1.25$$

$$b = 40 \text{ in.}$$

$$B = 1.3 \text{ psi}$$

$$T = 1,000 \text{ msec}$$

Step 2: Select the minimum glazing thickness.

Enter Figures 4 and 5 which apply for the given design parameters. From Figure 5 find the minimum glazing thickness required is:

$$t = 3/16 \text{ in. nominal}$$

ANS

Step 3: Calculate the static ultimate uniform load that produces the same maximum frame load as the blast load.

Enter Table 1 for tempered glass with $b = 40 \text{ in.}$, $a/b = 1.25$ and $t = 3/16 \text{ in.}$, and find the static ultimate uniform load capacity of the glazing is:

$$r_u = 2.31 \text{ psi}$$

Thus, the window frame must be designed to safely support, without undue deflection, a static uniform load equal to 2.31 psi applied normal to the glazing.

Step 4: Calculate the design loading for the window frame.

Enter Table 2 with $a/b = 1.25$, and find by interpolation the design coefficients for the frame loading are:

$$C_R = 0.077$$

$$C_x = 0.545$$

$$C_y = 0.543$$

From Equation 3, the concentrated load in each corner of the pane is:

$$R \text{ (corners)} = -0.077 (2.31)(40)^2 = -285 \text{ lb} \quad \text{ANS}$$

From Equation 1, the design loading for the frame in the long direction (a) is:

$$V_x = 0.545 (2.31)(40) \sin (\pi x/50)$$

$$V_x = 50.4 \sin (\pi x/50) \text{ lb/in.} \quad \text{ANS}$$

From Equation 2, the design loading for the frame in the short direction (b) is:

$$V_y = 0.543 (2.31)(40) \sin (\pi y/40)$$

$$V_y = 50.2 \sin (\pi y/40) \text{ lb/in.} \quad \text{ANS}$$

Distribution of the design load on the frame is shown in Figure 17.

5.4 Problem 4 -- Design Loads for Multi-pane Frame

Given: A nonoperable window consists of four equal size panes of glass. Glazing: heat-treated tempered glass meeting Federal Specification DD-G-1403B and ANSI Z97.1-1975. Dimensions of the panes: a = 22.5 in., b = 18 in. Blast loading: B = 5.0 psi, T = 500 msec.

Find: Minimum thickness of glazing required for $P(F) \leq 0.001$ and the design loads for the framing system.

Solution: Step 1: Tabulate the design parameters needed to enter Figures 2 to 11.

Glazing = tempered glass

$$a/b = 22.5/18 = 1.25$$

$$b = 18 \text{ in.}$$

$$B = 5.0 \text{ psi}$$

$$T = 500 \text{ msec}$$

Step 2: Select the minimum glazing thickness.

Enter Figures 4 and 5 which apply for the given design parameters.

From Figure 5, find the minimum glazing thickness required is:

$$t = 3/16 \text{ in. nominal}$$

ANS

Step 3: Calculate the static ultimate uniform load that produces the same maximum reactions on the window frame as the blast load.

Enter Table 1 with $b = 18 \text{ in.}$, $a/b = 1.25$ and $t = 3/16 \text{ in.}$, and find the static ultimate uniform load capacity of the glazing is:

$$r_u = 9.18 \text{ psi}$$

The window frame must be designed to safely support, without undue deflections, a static uniform load equal to 9.18 psi applied normal to the glazing.

Step 4: Calculate the design loading for the window frame.

Enter Table 2 with $a/b = 1.25$. With interpolation, the design coefficients for the frame loading are:

$$C_R = 0.077$$

$$C_x = 0.545$$

$$C_y = 0.543$$

From Equation 3, the concentrated loads in the corners of each pane are:

$$R \text{ (corners)} = -0.077 (9.18)(18)^2 = -229 \text{ lb} \quad \text{ANS}$$

From Equation 1, the design loading for the long spans of the frame and mullions are:

$$\begin{aligned} V_x &= 0.545 (9.18)(18) \sin (\pi x/22.5) \\ &= 90.1 \sin (\pi x/22.5) \text{ lb/in.} \quad \text{ANS} \end{aligned}$$

From Equation 2, the design loading for the short spans of the frame and mullions are:

$$\begin{aligned} V_y &= 0.543 (9.18)(18) \sin (\pi y/18) \\ &= 89.7 \sin (\pi y/18) \text{ lb/in.} \quad \text{ANS} \end{aligned}$$

The design loads for the window frame are shown in the following figure and table and are illustrated below.

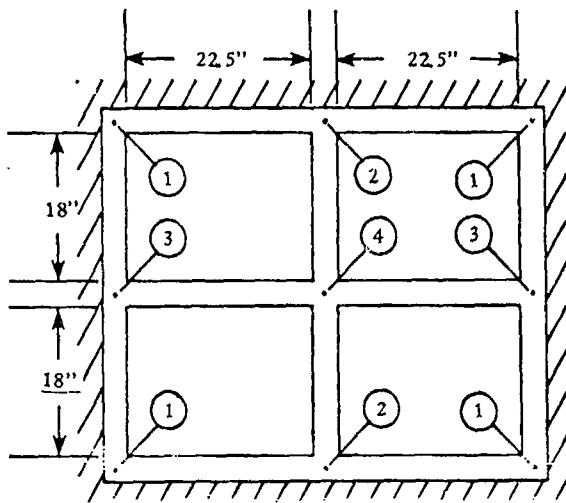

Locations	Design Load
①	R
② ③	2R
④	4R
①-②	V_x
①-③	V_y
②-④	$2V_y$
③-④	$2V_x$

5.5 Problem 5 -- Design Acceptance Based upon Certification Test Results

Given: A window 30 x 30 x 1/4-inch with a single pane of tempered glass is designed to safely resist a blast load, B , of 4.0 psi with an effective blast duration, T , of 200 msec. Certification testing involved testing three window assemblies ($n = 3$) to failure. Failure loads, \hat{f}_i , were recorded at 8.84, 9.51, and 10.8 psi.

Find: Determine if the window design is acceptable based on results from the certification tests.

Solution: Step 1: Tabulate the design parameters needed to enter Table 1:

$$b = 30 \text{ in.}$$

$$a/b = 30/30 = 1.00$$

$$t = 1/4 \text{ in. nominal}$$

Step 2: Employing Table 1, select the static ultimate load, r_u , corresponding to the pane geometry.

$$r_u = 6.59 \text{ psi}$$

Step 3: Calculate the arithmetic mean, \bar{r} , of all the samples tested.

Using Equation 5:

$$\bar{r} = \frac{\sum_{i=1}^n \hat{r}_i}{n} = \frac{(8.84 + 9.51 + 10.8)}{3} = 9.72 \text{ psi}$$

Step 4: Using either Equation 6 or 7, calculate the sample standard deviation, s .

The sample standard deviation, s , is calculated using Equation 6 as,

$$\begin{aligned} s &= \sqrt{\frac{\sum_{i=1}^n (\hat{r}_i - \bar{r})^2}{(n - 1)}} \\ &= \sqrt{\frac{(8.84 - 9.72)^2 + (9.51 - 9.72)^2 + (10.8 - 9.72)^2}{(3 - 1)}} \\ &= 1.01 \text{ psi} \end{aligned}$$

Step 5: Verify that the sample standard deviation, s , is larger than the minimum value, s_{\min} , prescribed in Equation 8.

$$s = 1.01 \text{ psi} > s_{\min} = 0.145 r_u = 0.145 (6.59) = 0.956 \text{ psi}$$

Thus, $s = 1.01 \text{ psi}$ is the appropriate value to use in subsequent calculations.

Step 6: Using Table 3, select the acceptance coefficient, α , that correlates with the three samples tested.

Entering Table 3, with $n = 3$, find:

$$\alpha = 3.05$$

Step 7: Verify that the window and frame passed the certification tests by meeting the conditions of Equation 4:

$$\bar{r} = 9.72 \text{ psi} > r_u + s \alpha = 6.59 + 1.01 (3.04) = 9.67 \text{ psi}$$

Therefore, the window assembly design is considered safe for the prescribed blast loading.

5.6 Problem 6 -- Design Rejection Based upon Certification Test Results

Given: A window 30 x 30 x 1/4 inch with a single pane of tempered glass is designed to safely resist a blast load, B , of 4.0 psi with an effective blast duration, T , of 200 msec. Certification testing involved testing three window assemblies ($n = 3$) to failure. Failure loads, \hat{r}_i , were 6.39, 7.49, and 8.47 psi.

Find: Determine if the window design is acceptable based upon results from the certification tests.

Solution: Step 1: Tabulate the design parameters needed to enter Table 1.

$$b = 30 \text{ in.}$$

$$a/b = 30/30 = 1.00$$

$$t = 1/4 \text{ in.}$$

Step 2: Employing Table 1 select the static ultimate load, r_u , corresponding to the pane geometry.

$$r_u = 6.59 \text{ psi}$$

Step 3: Calculate the arithmetic mean, \bar{r} , of all the samples tested:

$$\bar{r} = \frac{\sum_{i=1}^n \hat{r}_i}{n} = \frac{(6.39 + 7.49 + 8.47)}{3} = 7.45 \text{ psi}$$

Step 4: Employing either Equation 6 or 7, calculate the sample standard deviation, s .

The sample standard deviation, s , is calculated using Equation 6 as:

$$s = \sqrt{\frac{\sum_{i=1}^n \frac{\hat{r}_i - \bar{r}}{(n-1)}^2}{(n-1)}} =$$
$$\sqrt{\frac{(6.39 - 7.45)^2 + (7.49 - 7.45)^2 + (8.47 - 7.45)^2}{(3 - 1)}}$$
$$= 1.04 \text{ psi}$$

Step 5: Verify that the sample deviation, s , is larger than the minimum value, s_{\min} , prescribed in Equation 8.

$$s = 1.04 \text{ psi} > s_{\min} = 0.145 r_u = 0.145 (6.59) = 0.956 \text{ psi}$$

Thus, $s = 1.04 \text{ psi}$ is the appropriate value to use in subsequent calculations.

Step 6: Using Table 3, select the acceptance coefficient, α , and the rejection coefficient, β , for $d = 3$. Entering Table 3 with $n = 3$, find,

$$\alpha = 3.05$$

$$\beta = 0.871$$

Step 7: Verify if the window and frame passed the certification tests by meeting the conditions of Equation 4:

$$\bar{r} = 7.45 \text{ psi} < r_u + s \alpha = 6.59 + 1.04 (3.04) = 9.75 \text{ psi}$$

Therefore, the window assembly design does not satisfy Equation 4 and is considered unsafe for the prescribed design blast loading.

Step 8: Determine if the window design should be abandoned or of additional testing is justified. From Equation 9,

$$\bar{r} = 7.45 \text{ psi} < r_u + 5 \beta = 6.59 + 1.04 (0.871) = 7.50 \text{ psi}$$

Therefore, with a level of confidence of 90%, additional testing will not lead to acceptance of the window design. A new design should be chosen and certified.

6. LIST OF SYMBOLS

- a Long dimension of glass pane, in.
- B Peak blast overpressure, psi
- b Short dimension of glass pane, in.
- C Shear coefficient for load passed from glass pane to its support frame
- D Modulus of rigidity of glass pane, in-lb
- E Modulus of elasticity, psi
- f_u Design stress and allowable principal tensile stress in glass pane for prescribed P(F), psi
- f_y Yield stress of frame members and fasteners, psi
- I Moment of inertia of window frame, in.⁴
- n Number of window assemblies tested

M_e	Effective total mass (lb-ms ² /in.)
P	Blast overpressure at any time, psi
$P(F)$	Probability of failure of glass pane
R	Uplifting nodal force applied by glass pane to corners of frame, lb
r	Resistance, psi
\hat{r}	Test load at failure of frame or glass during certification tests, psi
\bar{r}	Mean failure load of n samples, psi
r_u	Uniform static load capacity of the glass pane, psi
\bar{r}_u	Uniform static negative load capacity of the window assembly, psi
s	Sample standard deviation, psi
T	Effective duration of blast load, msec
t	Nominal thickness of glass pane, in.; elapsed time, msec
V_x	Static load applied by glass pane to long edge of frame, lb/in.
V_y	Static load applied by glass pane to short edge of frame, lb/in.
x	Distance from corner measured along long edge of glass pane, in.
X	Center deflection of pane, in.
X_u	Center deflection of pane at r_u , in.
α	Acceptance coefficient
β	Rejection coefficient
ν	Poisson's ratio

7. BIBLIOGRAPHY

1. G.E. Meyers. Preliminary design procedure for blast-hardened window panes, Naval Civil Engineering Laboratory, Technical Memorandum 51-83-03. Port Hueneme, Calif., Jan 1981.
2. G.E. Meyers. A review of adaptable methodology for development of a design procedure for blast hardened windows, Naval Civil Engineering Laboratory, Special Report. Port Hueneme, Calif., Aug 1982.
3. C.V.G. Vallabhan and B.Y. Wang. Nonlinear analysis of rectangular glass plates by finite difference method, Texas Technical University, Institute for Disaster Research. Lubbock, Texas, Jun 1981.
4. D.M. Moore. Proposed method for determining the thickness of glass in solar collector panels, Jet Propulsion Laboratory, Publication 80-34. Pasadena, Calif., Mar 1980.
5. D.M. Moore. Thickness sizing of glass plates subjected to pressure loads, FSA Task Report No. 5101-291. Pasadena, Calif., Aug 1982.
6. PPG glass thickness recommendations to meet architect's specified 1-minute wind load, PPG Industries. Pittsburg, Pa, Mar 1981.
7. S. Weissman, N. Dobbs, W. Stea, and P. Price. Blast capacity evaluation of glass windows and aluminum window frames, U.S. Army Armament Research and Development Command, ARLCO-CR-78016. Dover, N.J., Jun 1978.
8. W.L. Beason and J.R. Morgan. "A glass failure prediction model," submitted for publication in the Journal of the Structural Division, American Society of Civil Engineers.
9. W.L. Beason. TAMU glass failure prediction model, preliminary report, Texas A&M University. College Station, Tex., Mar 1982.

10. W.L. Beason. A failure prediction model for window glass, Texas Technical University, NSF/RA 800231. Lubbock, Tex., May 1980.
11. S. Levy. Bending of rectangular plates with large deflections, NACA TechNote 845, 1942.
12. D. Anians. Experimental study of edge displacements of laterally loaded window glass plates, Institute for Disaster Research, Texas Technical University. Lubbock, Tex., Jun 1980.
13. S. Timoshenko and S. Woinowsky-Krieger. Theory of plates and shells. New York, N.Y., McGraw-Hill Book Company. 1959.
14. Safety performance specifications and methods of test for safety glazing material used in buildings, American National Standards Institute, ANSI Z97.1-1975. New York, N.Y., 1975.
15. A method for improving the shatter resistance of window glass, U.S. Army Picatinny Arsenal, National Bomb Data Center, General Information Bulletin 73-9. Dover, N.J., Nov 1973.
16. Glass, plate (float), sheet, figured, and spandrel (heat strengthened and fully tempered), General Service Administration, Federal Specification DD-G-1403B. Washington, D.C., 1972.
17. Structural performance of glass in exterior windows, curtain walls, and doors under the influence of uniform static loads by destructive method, American Society for Testing Materials, ASTM Standard (draft), Draft of proposed standard by ASTM Committee E06.51. Philadelphia, Pa., Oct 1982.
18. Federal specification glass, plate, sheet, figured (float, flat, for glazing, corrugated, mirrors and other uses), General Service Administration, Federal Specification DD-G-451d. Washington, D.C., 1977.

8. ACKNOWLEDGMENTS

The authors wish to express their appreciation and gratitude to all the following dedicated scientists, engineers and professionals who made this study possible. We thank Dr. Lynn Beason and Dr. James Morgan of Texas A&M University for their pioneering and high quality work on maximum allowable stress levels in glass. We also thank Mr. Donald Moore of the Jet Propulsion Laboratory for his work on the load, stress, and deflection relationships of glass panes. Additionally, we thank Dr. J. Minor and Dr. C.V.G. Vallabhan of Texas Technical University for their unselfish and excellent advice.

Table 1. Static Ultimate loads, r_u (psi) for Testing Certification of Tempered Glass

b (in.)	a/b = 1.00*					a/b = 1.25					a/b = 1.50								
	a/b = 1.00*		a/b = 1.00*		a/b = 1.00*		a/b = 1.25		a/b = 1.25		a/b = 1.25		a/b = 1.50		a/b = 1.50		a/b = 1.50		
	$t=1/2$ in.	$t=3/8$ in.	$t=1/4$ in.	$t=3/16$ in.	$t=1/2$ in.	$t=3/8$ in.	$t=1/4$ in.	$t=3/16$ in.	$t=1/2$ in.	$t=3/8$ in.	$t=1/4$ in.	$t=3/16$ in.	$t=1/2$ in.	$t=3/8$ in.	$t=1/4$ in.	$t=3/16$ in.	$t=1/2$ in.	$t=3/8$ in.	$t=1/4$ in.
12	106.0	60.7	22.6	16.9	80.8	46.7	19.3	13.0	64.5	38.5	13.7	11.3	38.5	13.7	11.3	64.5	38.5	13.7	11.3
14	76.2	39.8	17.5	16.2	58.8	33.7	13.5	11.1	46.9	27.5	11.4	10.1	27.5	11.4	10.1	46.9	27.5	11.4	10.1
16	58.1	30.5	13.7	13.7	44.7	25.9	11.8	11.2	36.8	20.6	9.95	9.08	20.6	9.95	9.08	36.8	20.6	9.95	9.08
18	45.5	24.8	10.9	10.9	34.8	20.9	11.7	9.18	28.5	16.7	9.49	8.09	16.7	9.49	8.09	28.5	16.7	9.49	8.09
20	33.2	20.6	8.12	8.12	28.0	17.5	10.5	7.71	22.7	12.5	9.15	6.76	12.5	9.15	6.76	22.7	12.5	9.15	6.76
22	27.8	17.4	7.04	7.04	23.4	13.3	8.93	6.62	18.5	11.0	7.88	5.57	11.0	7.88	5.57	18.5	11.0	7.88	5.57
24	23.8	15.3	6.35	6.35	20.0	11.9	7.74	5.55	15.9	10.2	6.79	4.73	10.2	6.79	4.73	15.9	10.2	6.79	4.73
26	20.7	14.6	5.57	5.57	17.4	11.0	6.80	4.90	13.9	9.34	5.77	4.18	9.34	5.77	4.18	13.9	9.34	5.77	4.18
28	18.2	14.5	4.96	4.96	15.5	10.8	6.02	4.34	11.2	9.07	5.03	3.73	9.07	5.03	3.73	11.2	9.07	5.03	3.73
30	16.1	14.0	4.47	4.47	14.0	10.7	5.21	3.87	10.4	8.81	4.42	3.32	8.81	4.42	3.32	10.4	8.81	4.42	3.32
32	14.7	12.6	4.05	4.05	11.4	10.3	4.71	3.47	9.83	8.54	4.02	2.96	8.54	4.02	2.96	9.83	8.54	4.02	2.96
34	14.2	10.9	4.88	3.69	10.7	9.30	4.27	3.13	9.17	8.20	3.67	2.65	8.20	3.67	2.65	9.17	8.20	3.67	2.65
36	13.8	9.97	4.67	3.39	10.4	8.42	3.88	2.84	8.79	7.43	3.33	2.34	7.43	3.33	2.34	8.79	7.43	3.33	2.34
38	13.7	9.16	4.12	3.12	10.4	7.70	3.54	2.59	8.71	6.78	3.04	2.12	6.78	3.04	2.12	8.71	6.78	3.04	2.12
40	13.5	8.55	3.81	2.88	10.3	7.07	3.25	2.31	8.36	6.20	2.77	1.94	6.20	2.77	1.94	8.36	6.20	2.77	1.94
42	12.5	7.99	3.54	2.67	10.2	6.53	2.99	2.12	8.23	5.68	2.53	1.79	5.68	2.53	1.79	8.23	5.68	2.53	1.79
44	11.0	7.41	3.29	2.45	9.42	6.05	2.76	1.97	8.19	5.11	2.27	1.57	5.11	2.27	1.57	8.19	5.11	2.27	1.57
46	10.3	6.90	3.08	2.28	8.72	5.61	2.56	1.83	7.70	4.70	2.10	1.31	4.70	2.10	1.31	7.70	4.70	2.10	1.31
48	9.58	6.43	2.88	2.14	8.10	5.06	2.32	1.65	7.16	4.34	1.95	1.11	4.34	1.95	1.11	7.16	4.34	1.95	1.11
50	8.97	5.99	2.71	2.01	7.57	4.76	2.16	1.40	6.60	4.00	1.80	1.00	4.00	1.80	1.00	6.60	4.00	1.80	1.00
52	8.50	5.58	2.54	1.89	7.09	4.48	2.02	1.20	6.10	3.70	1.70	0.90	3.70	1.70	0.90	6.10	3.70	1.70	0.90
54	8.07	5.22	2.37	1.75	6.60	4.20	1.85	1.00	5.60	3.40	1.60	0.80	3.40	1.60	0.80	5.60	3.40	1.60	0.80
56	7.68	4.85	2.24	1.65	6.10	4.00	1.70	0.90	5.10	3.10	1.50	0.70	3.10	1.50	0.70	5.10	3.10	1.50	0.70
58	7.25	4.51	2.12	1.56	5.60	3.80	1.60	0.80	4.60	2.80	1.40	0.60	2.80	1.40	0.60	4.60	2.80	1.40	0.60
60	6.87	4.09	2.01	1.40	5.10	3.60	1.50	0.70	4.10	2.60	1.30	0.50	2.60	1.30	0.50	4.10	2.60	1.30	0.50

b (in.)	a/b = 1.75					a/b = 2.00						
	a/b = 1.75		a/b = 1.75		a/b = 1.75		a/b = 2.00		a/b = 2.00		a/b = 2.00	
	$t=1/2$ in.	$t=3/8$ in.	$t=1/4$ in.	$t=3/16$ in.	$t=1/2$ in.	$t=3/8$ in.	$t=1/4$ in.	$t=3/16$ in.	$t=1/2$ in.	$t=3/8$ in.	$t=1/4$ in.	$t=3/16$ in.
12	57.9	32.7	13.0	9.98	51.1	29.4	11.6	8.57	44.5	25.5	9.5	7.16
14	42.2	23.6	10.3	6.85	37.1	21.3	8.94	5.83	39.5	19.5	8.0	6.00
16	31.3	17.8	8.58	6.79	28.1	16.2	7.26	5.24	32.5	14.5	7.0	4.80
18	26.4	13.9	7.62	6.69	22.0	12.9	5.37	5.15	27.5	11.5	6.0	4.00
20	19.5	11.8	7.01	5.84	17.7	10.5	5.07	5.00	22.5	9.5	5.0	3.50
22	15.9	10.1	6.73	4.95	14.6	8.86	4.99	4.48	18.5	8.5	4.5	3.00
24	13.3	9.03	5.83	4.28	12.3	7.77	4.87	3.85	15.5	7.5	4.0	2.50
26	11.8	8.10	5.12	3.76	10.5	6.87	4.64	3.38	13.5	6.5	3.5	2.00
28	10.4	7.34	4.50	3.37	9.11	5.34	4.07	2.99	12.5	5.5	3.0	1.50
30	9.39	7.08	4.02	3.00	8.20	5.08	3.62	2.66	11.5	5.0	2.5	1.00
32	8.66	6.82	3.62	2.63	7.44	4.97	3.26	2.35	10.5	4.5	2.0	0.75
34	7.99	6.56	3.31	2.36	6.78	4.86	2.94	2.10	9.5	4.0	1.5	0.50
36	7.37	6.30	3.01	2.13	6.21	4.74	2.66	1.88	8.5	3.5	1.0	0.35
38	6.93	6.02	2.73	1.94	5.05	4.60	2.42	1.61	7.5	3.0	0.75	0.25
40	6.60	5.77	2.56	1.73	4.78	4.53	2.20	1.31	6.5	2.5	0.50	0.15
42	6.26	4.94	2.25	1.42	4.60	4.49	2.00	1.08	5.5	2.0	0.35	0.10
44	5.93	4.55	2.08	1.18	4.60	4.49	2.00	1.08	4.5	1.5	0.25	0.05

*a = longest side of window; b = shortest side of window; t = nominal thickness of window.

Table 2. Coefficients for Frame Loading

a/b	C_R	C_x	C_y
1.00	0.065	0.495	0.495
1.10	0.070	0.516	0.516
1.20	0.074	0.535	0.533
1.30	0.079	0.554	0.551
1.40	0.083	0.570	0.562
1.50	0.085	0.581	0.574
1.60	0.086	0.590	0.583
1.70	0.088	0.600	0.591
1.80	0.090	0.609	0.600
1.90	0.091	0.616	0.607
2.00	0.092	0.623	0.614

Table 3. Statistical Acceptance and Rejection Coefficients

Number of Window Assemblies	Acceptance Coefficient	Rejection Coefficient
<u>n</u>	<u>α</u>	<u>β</u>
2	4.14	.546
3	3.05	.871
4	2.78	1.14
5	2.65	1.27
6	2.56	1.36
7	2.50	1.42
8	2.46	1.48
9	2.42	1.49
10	2.39	1.52
11	2.37	1.54
12	2.35	1.57
13	2.33	1.58
14	2.32	1.60
15	2.31	1.61
16	2.30	1.62
17	2.28	1.64
18	2.27	1.65
19	2.27	1.65
20	2.26	1.66
21	2.25	1.67
22	2.24	1.68
23	2.24	1.68
24	2.23	1.69
25	2.22	1.70
30	2.19	1.72
40	2.17	1.75
50	2.14	1.77

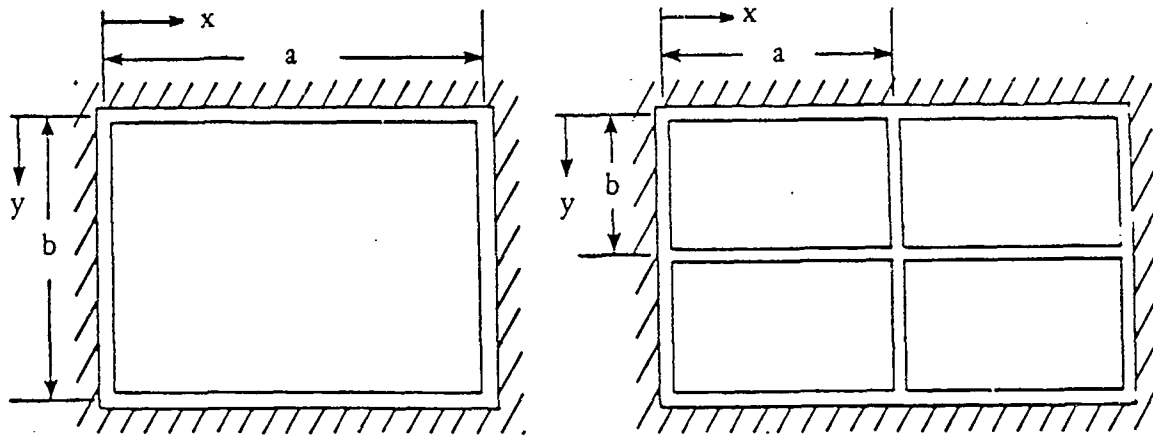

(a) Window pane geometry

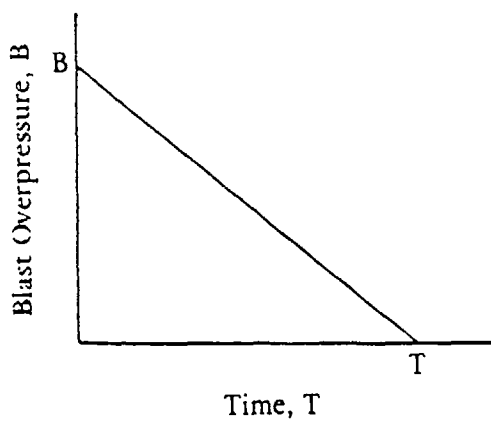

(b) Blast loading

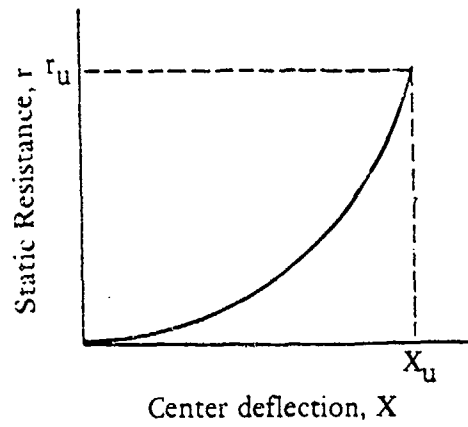

(d) Dynamic response model

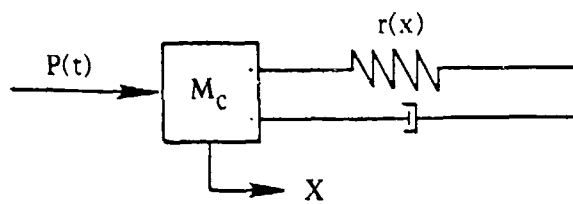

(c) Resistance of glass pane

Figure 1. Characteristic parameters for glass pane, blast loading, resistance function and response model.

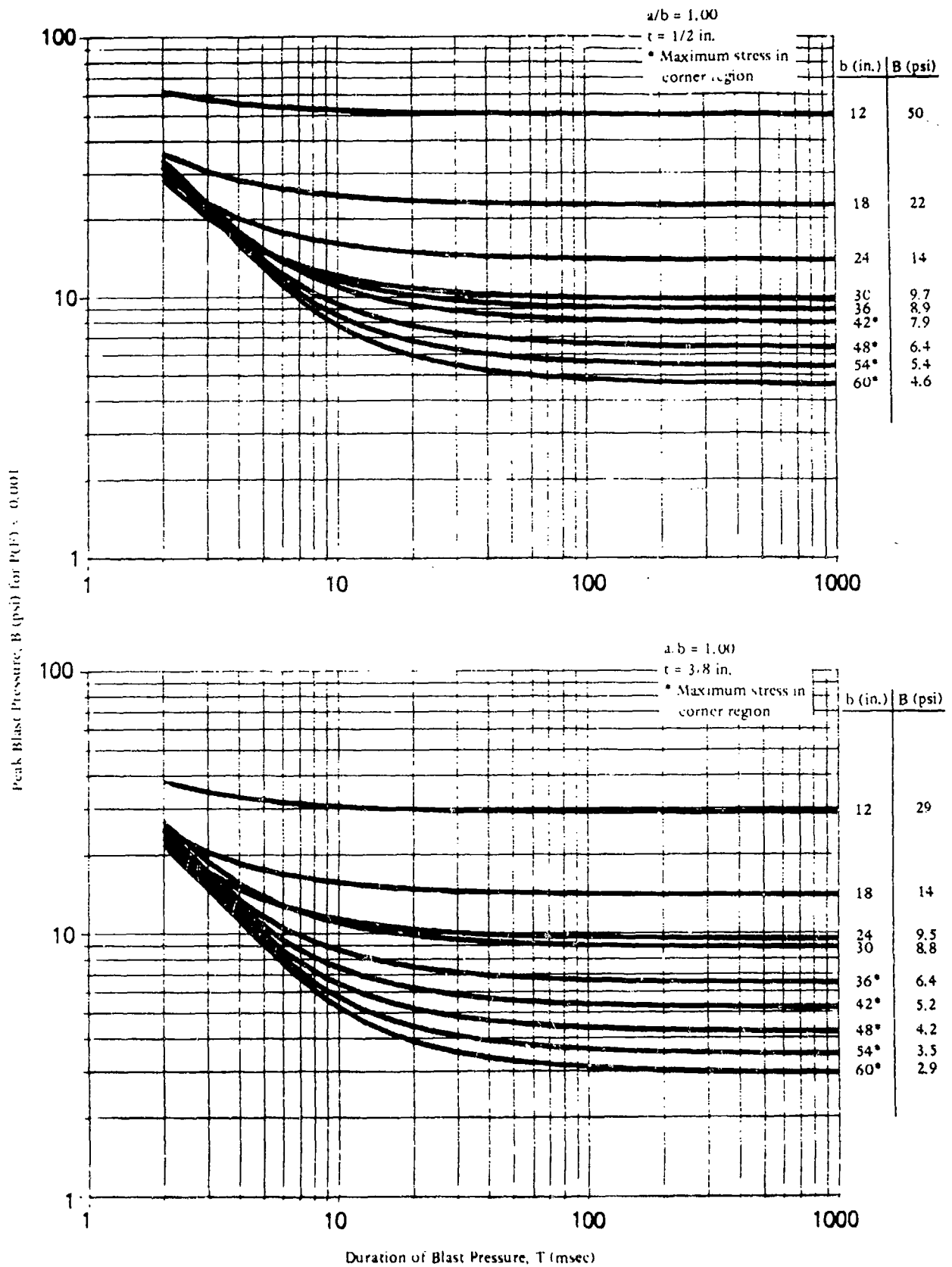

Figure 2. Peak blast pressure capacity for tempered glass panes: $a/b = 1.00$, $t = 1/2$ and $3/8$ in.

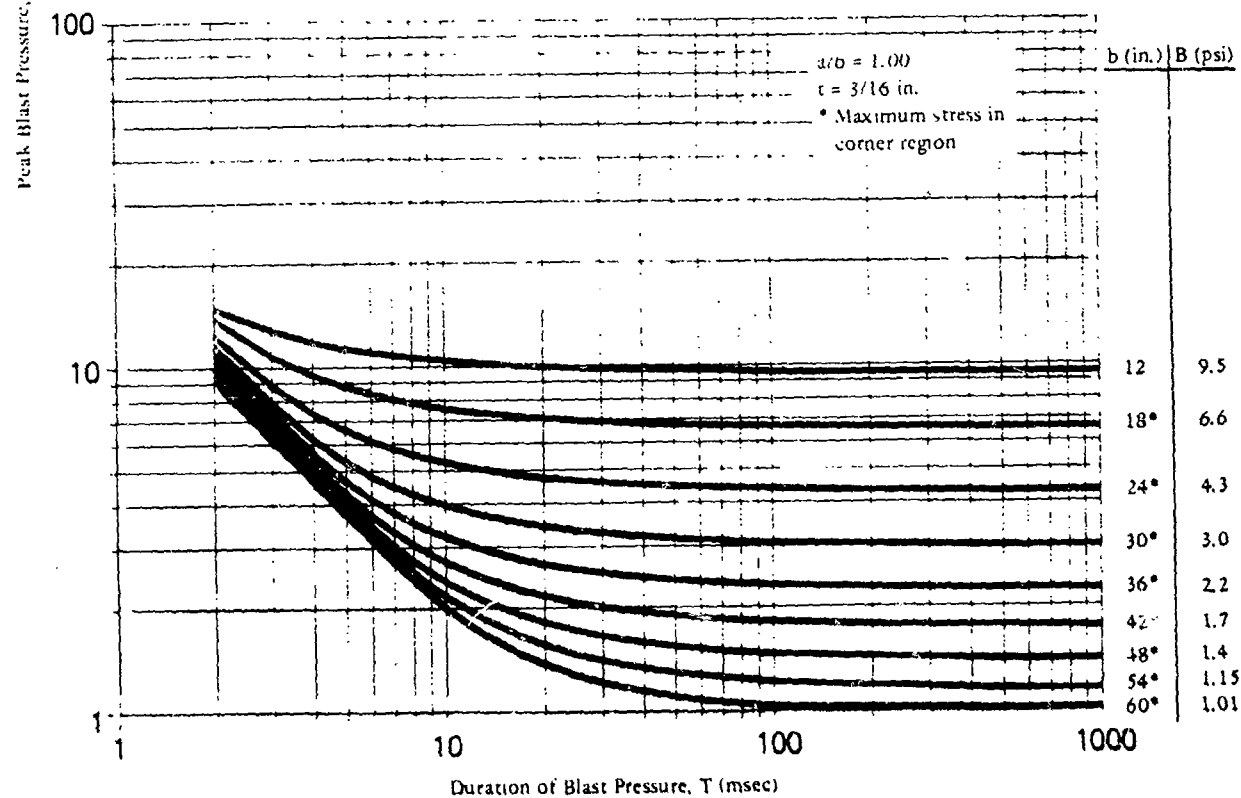
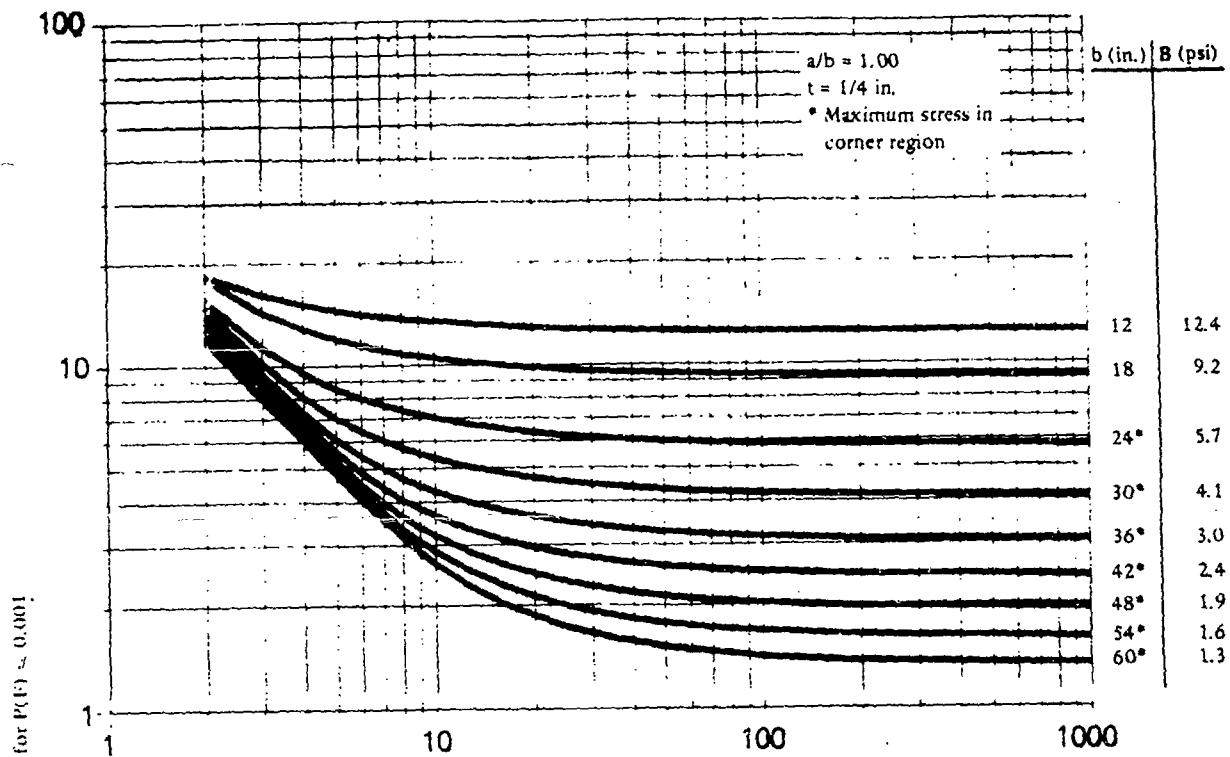

Figure 3. Peak blast pressure capacity for tempered glass panes: $a/b = 1.00$, $t = 1/4$ and $3/16$ in.

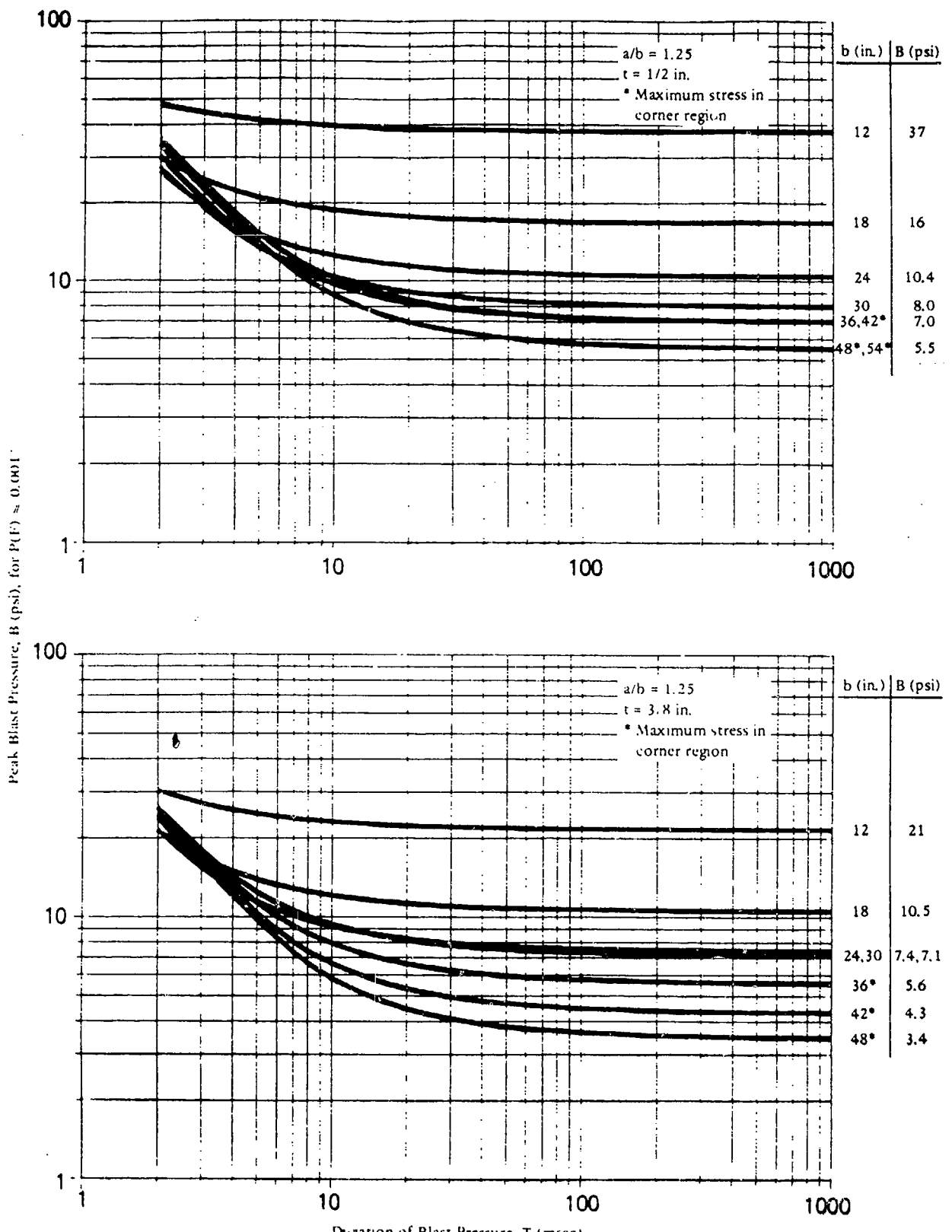

Figure 4. Peak blast pressure capacity for tempered glass panes: $a/b = 1.25$, $t = 1/2$ and $3/8$ in.

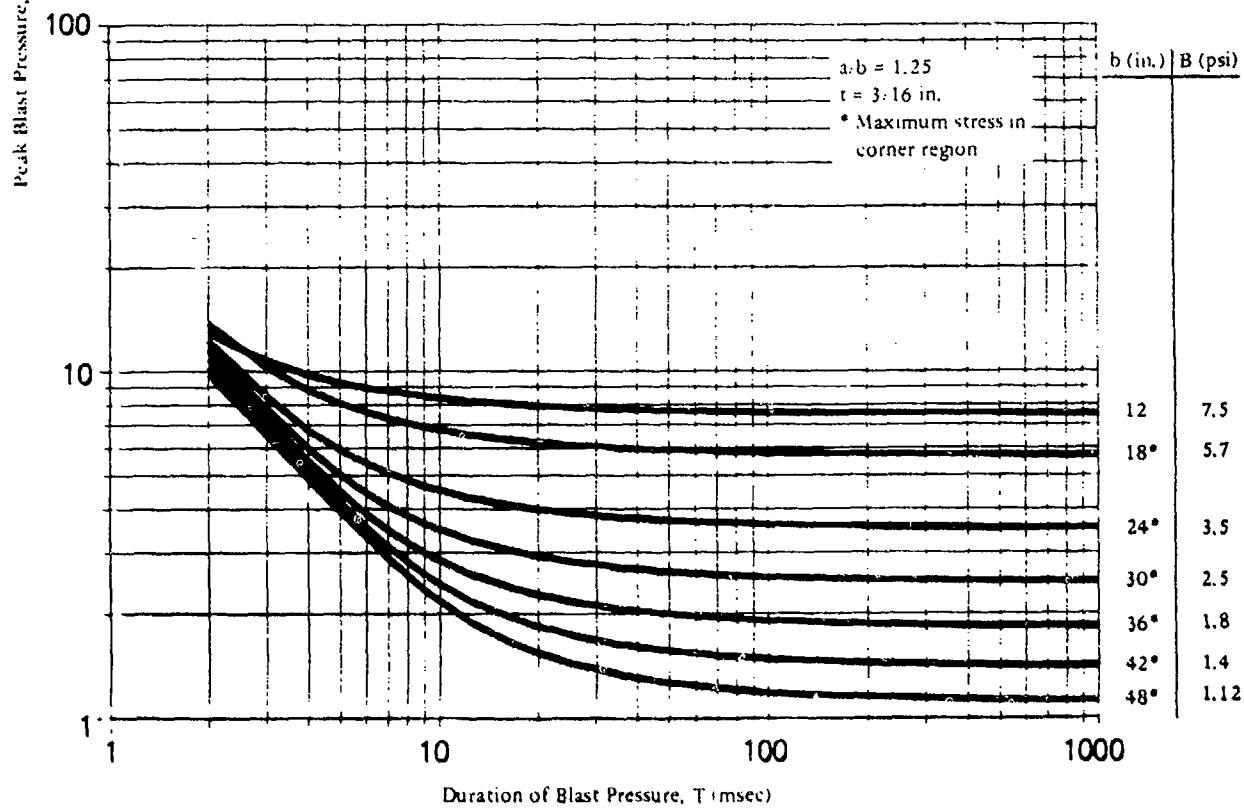
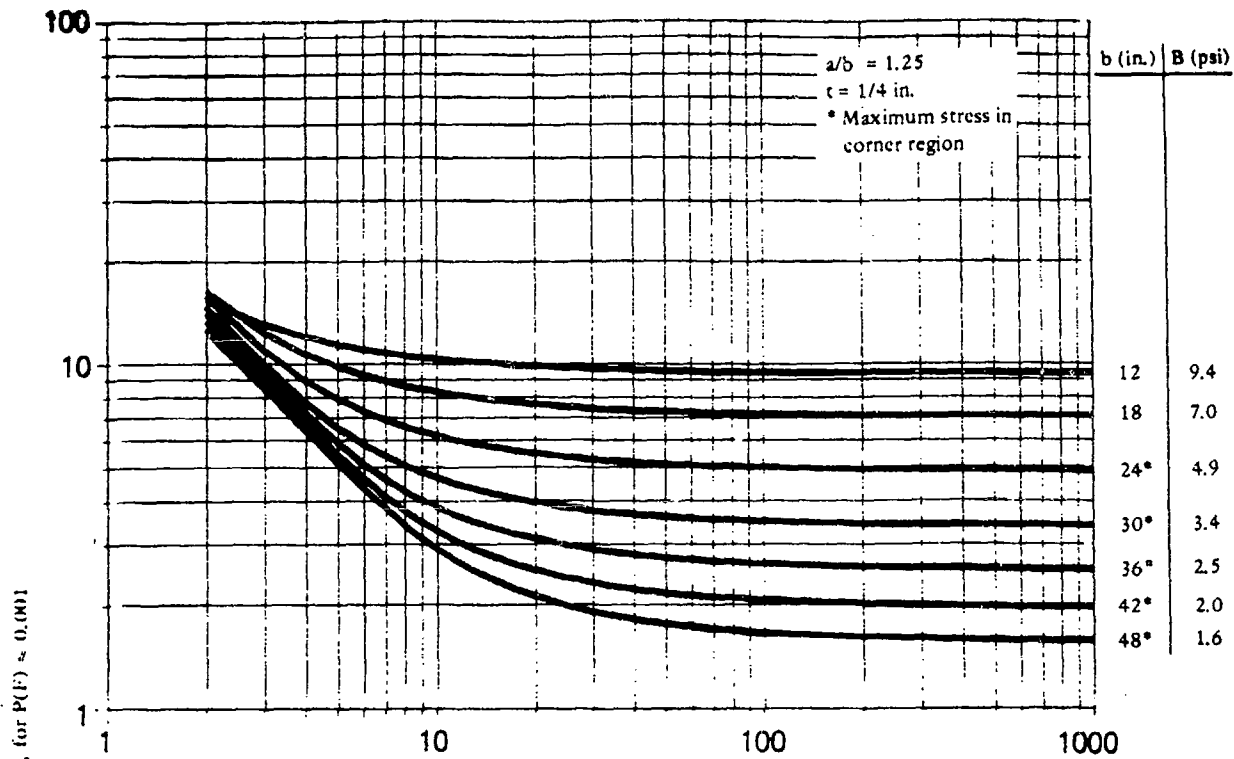

Figure 5. Peak blast pressure capacity for tempered glass panes: $a/b = 1.25$, $t = 1/4$ and $3/16$ in.

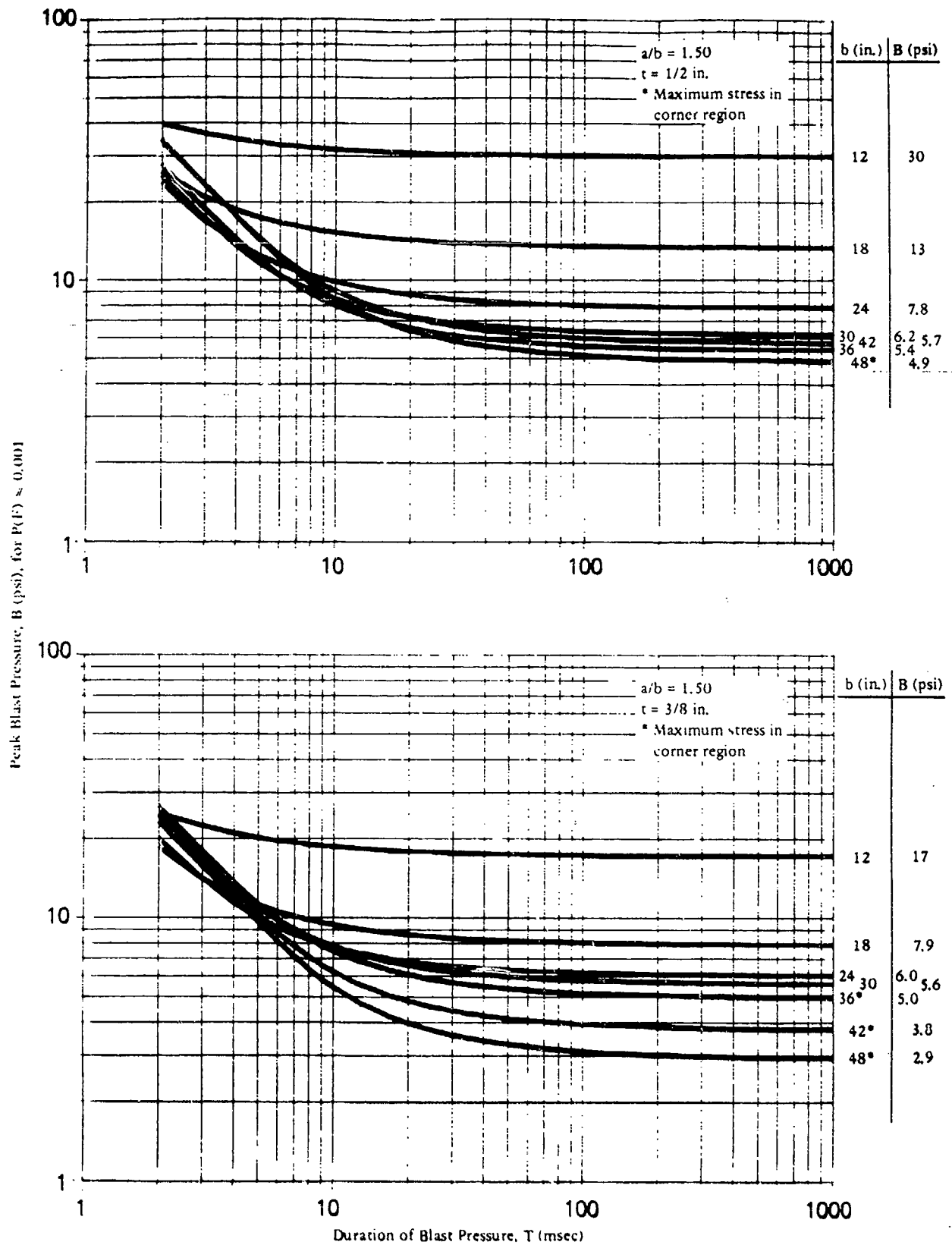

Figure 6. Peak blast pressure capacity for tempered glass panes: $a/b = 1.50$, $t = 1/2$ and $3/8$ in.

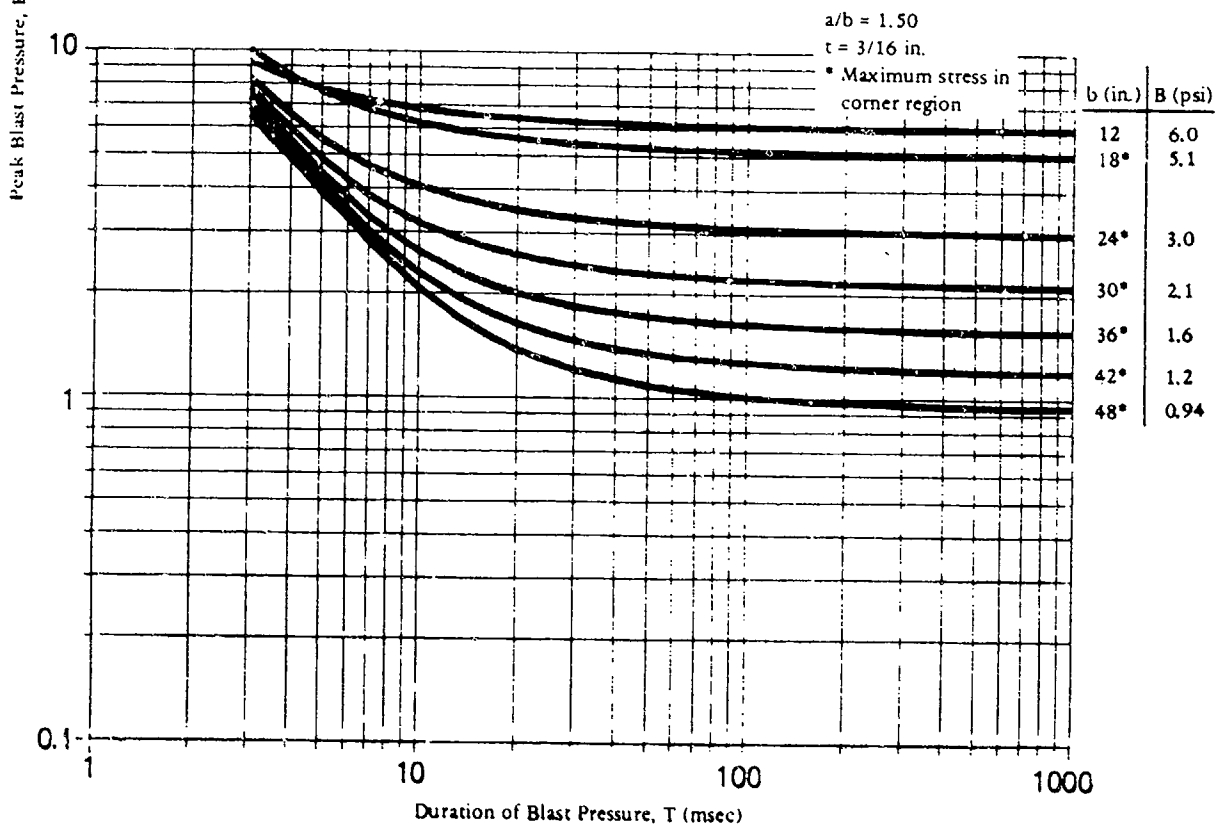
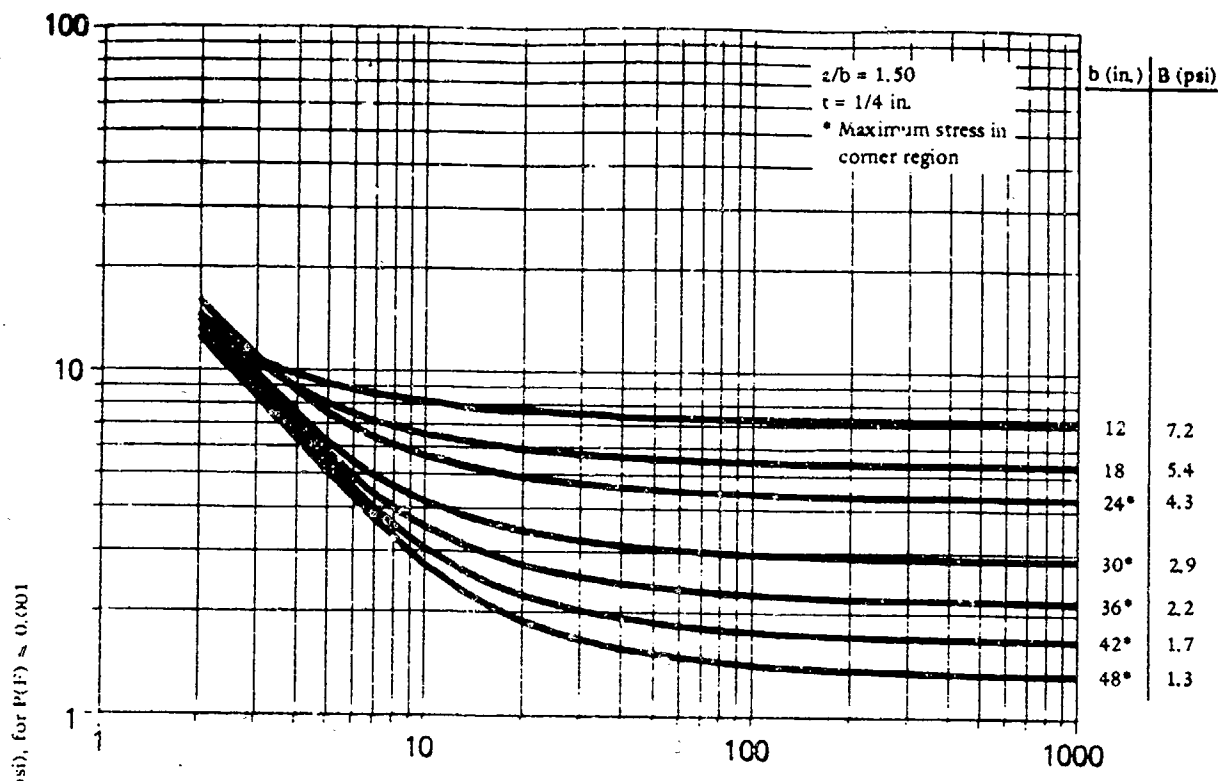

Figure 7. Peak blast pressure capacity for tempered glass panes: $a/b = 1.50$, $t = 1/4$ and $3/16$ in.

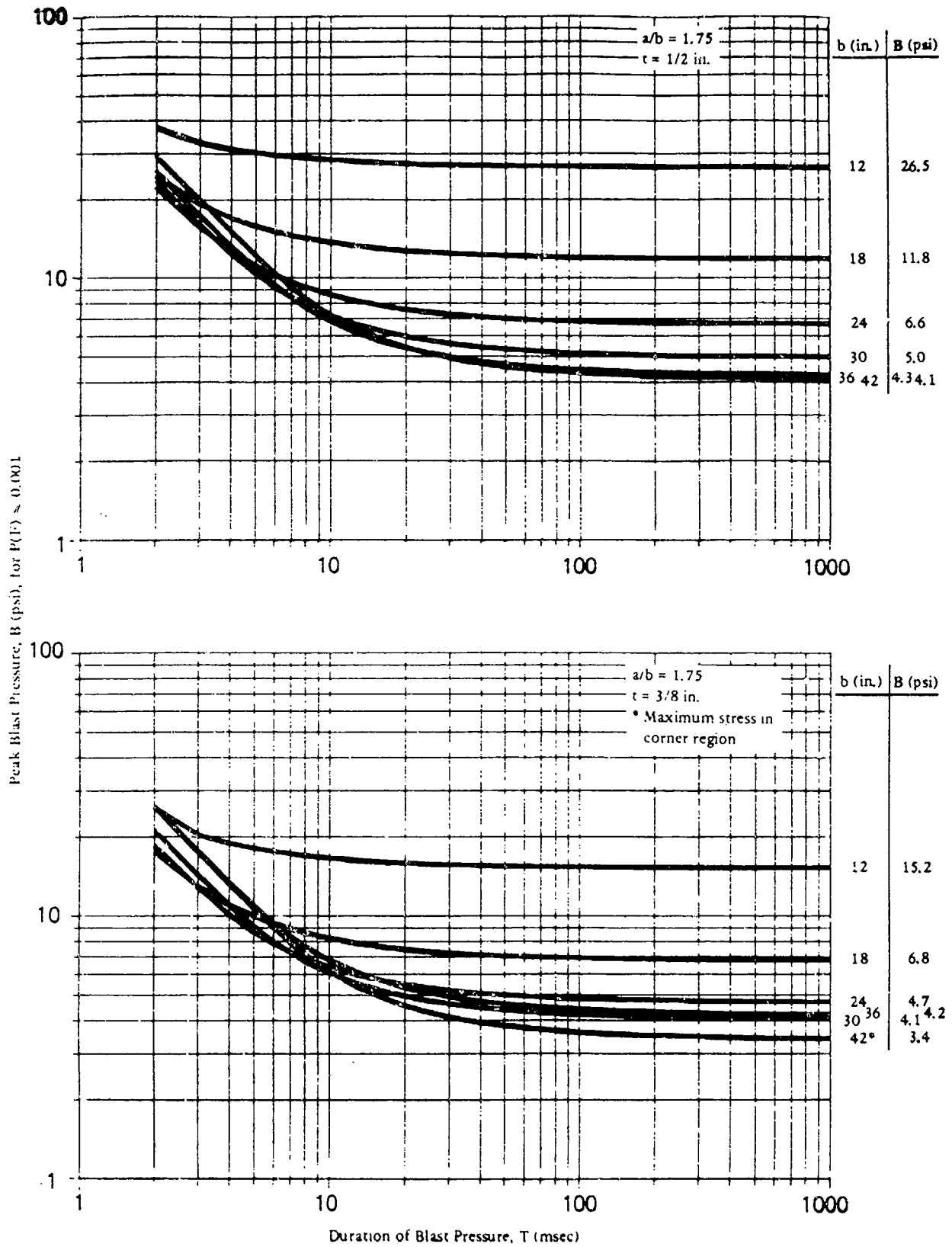

Figure 8. Peak blast pressure capacity for tempered glass panes: $a/b = 1.75$, $t = 1/2$ and $3/8$ in.

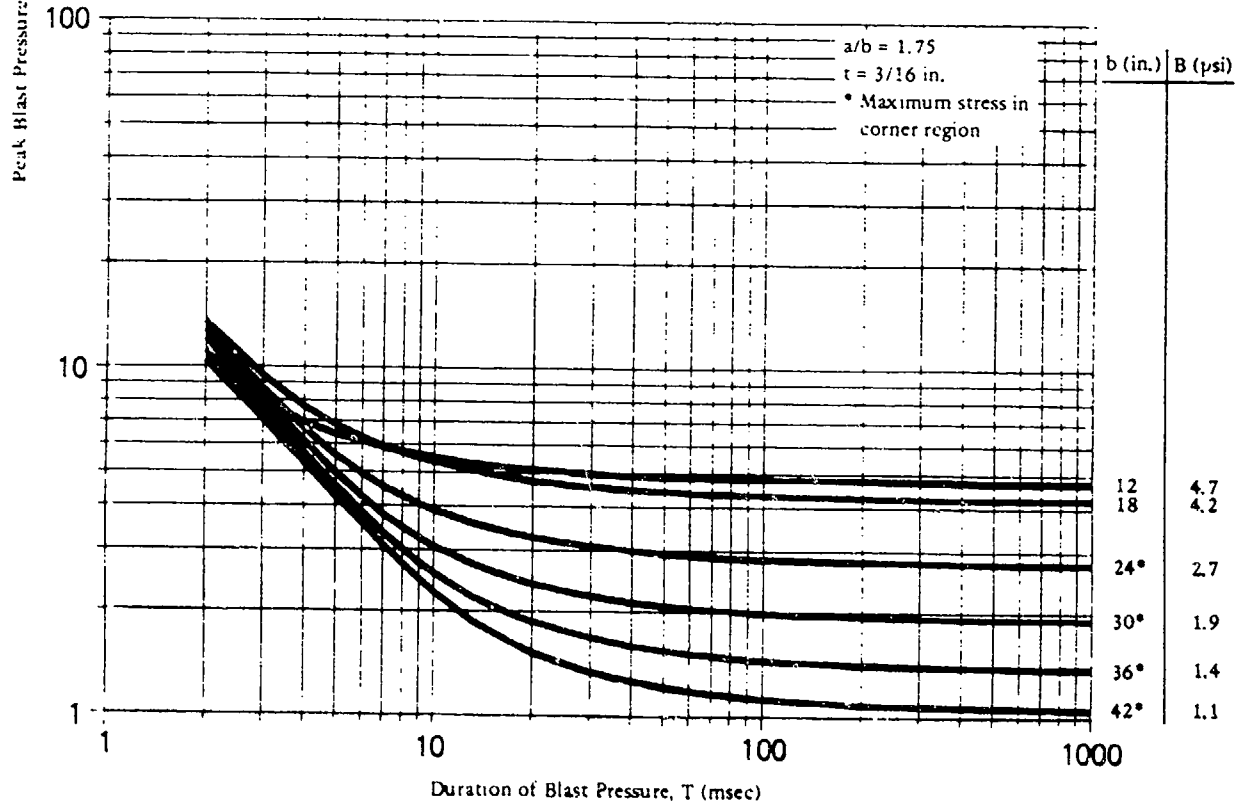
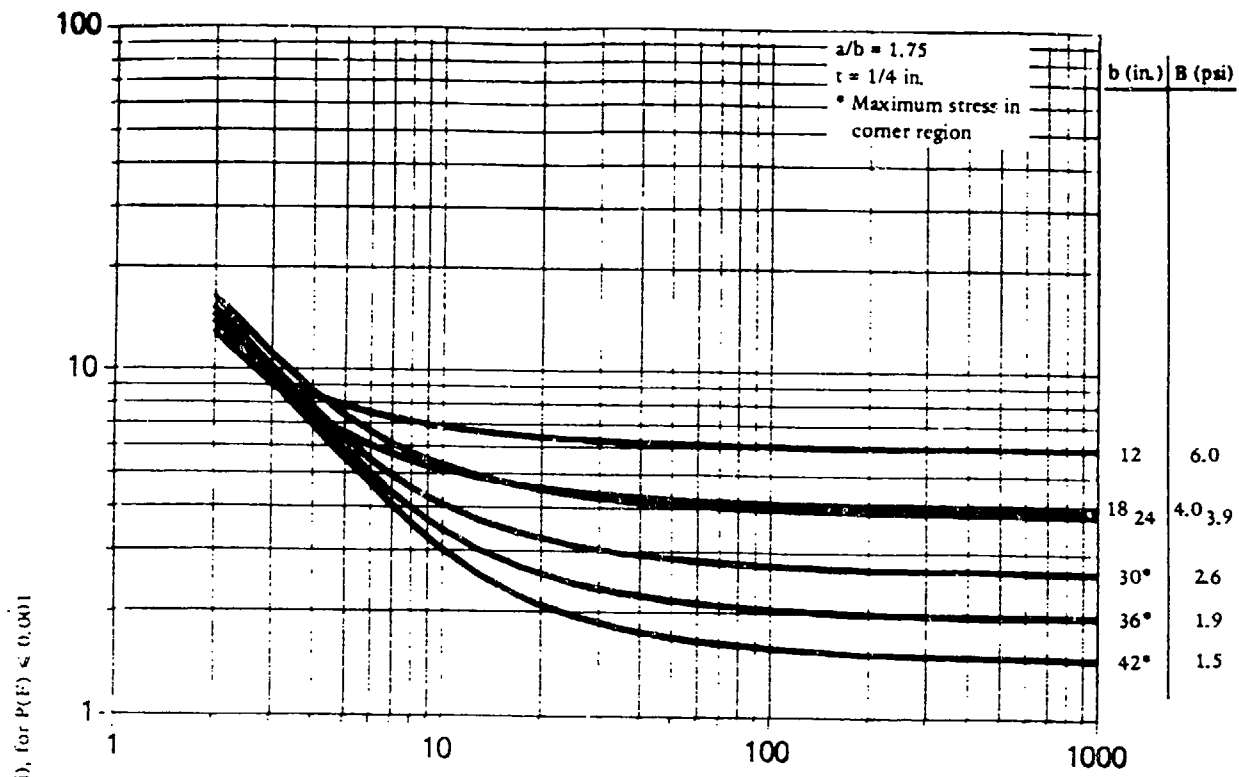

Figure 9. Peak blast pressure capacity for tempered glass panes: $a/b = 1.75$, $t = 1/4$ and $3/16$ in.

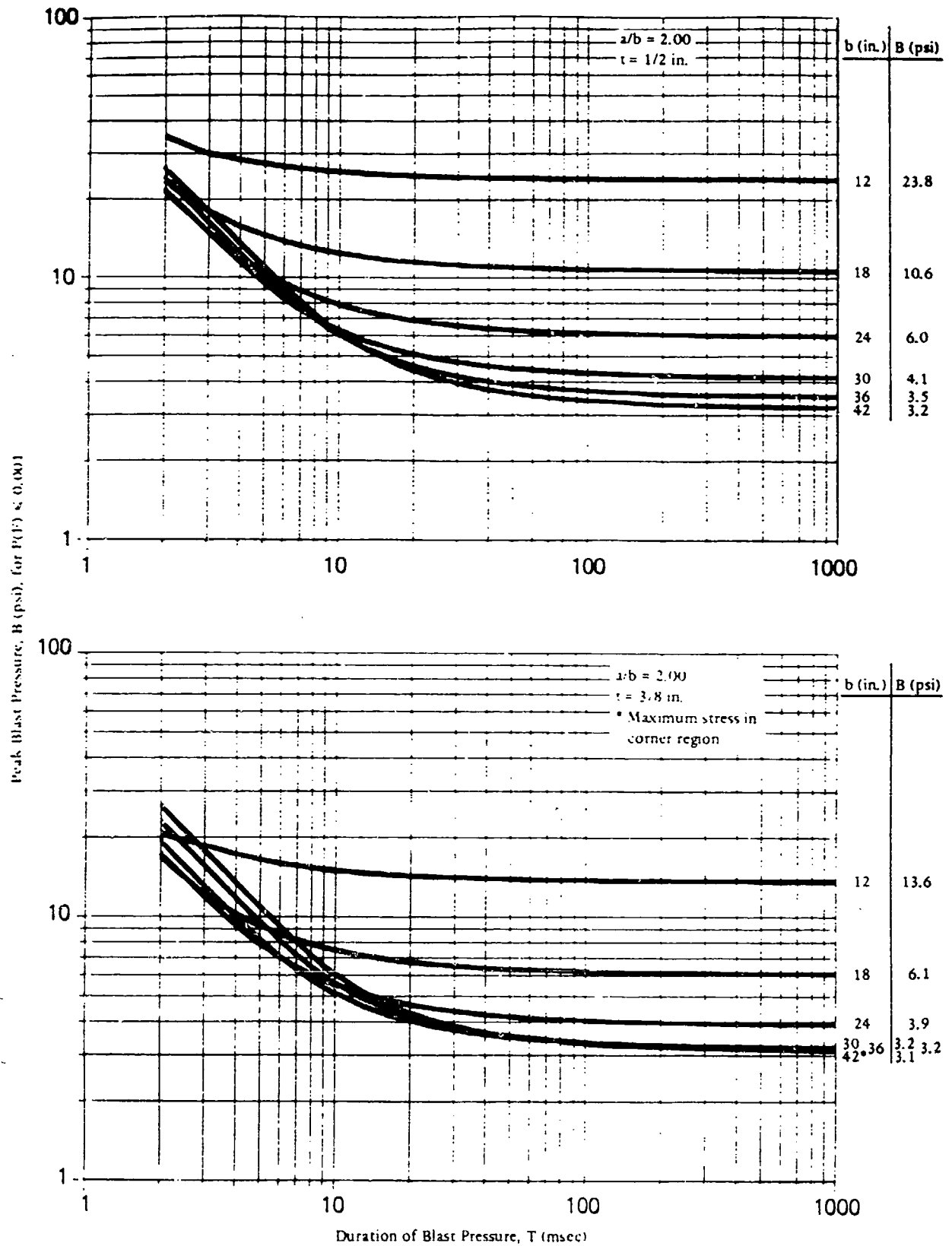

Figure 10. Peak blast pressure capacity for tempered glass panes: $a/b = 2.00$, $t = 1/2$ and $3/8$ in.

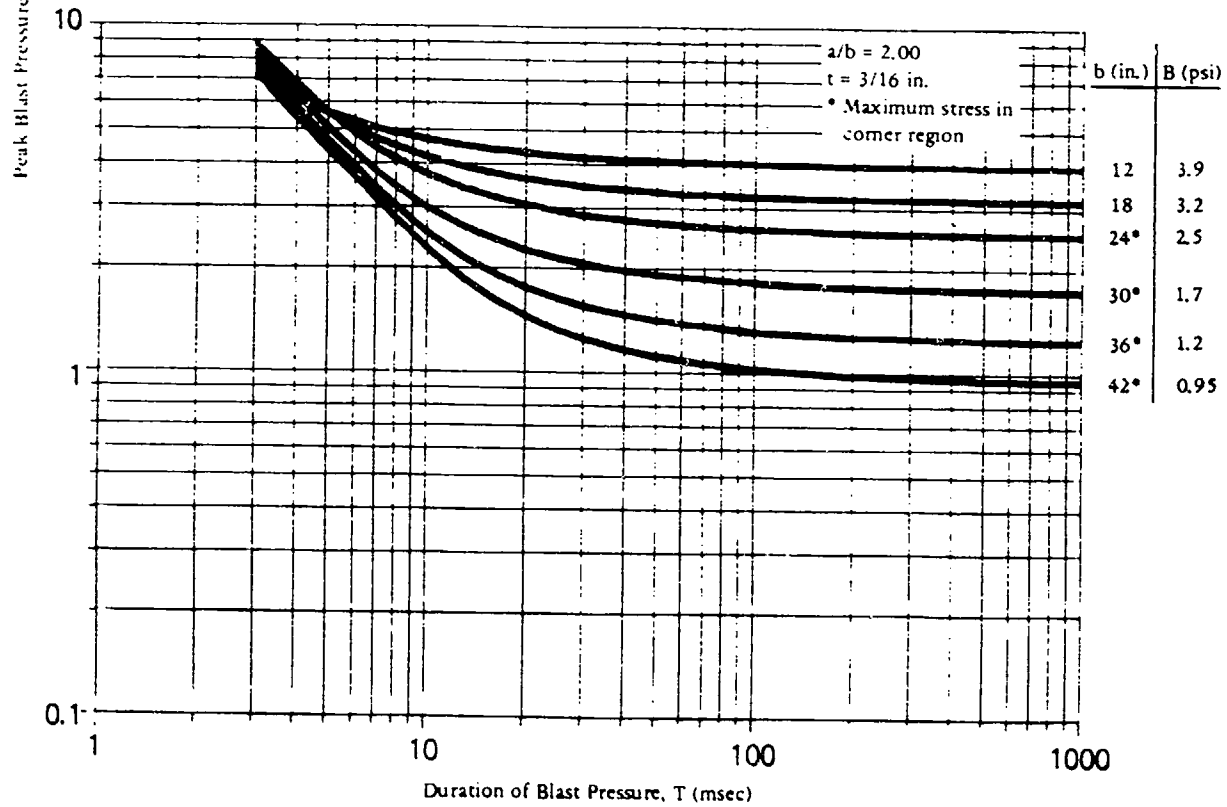
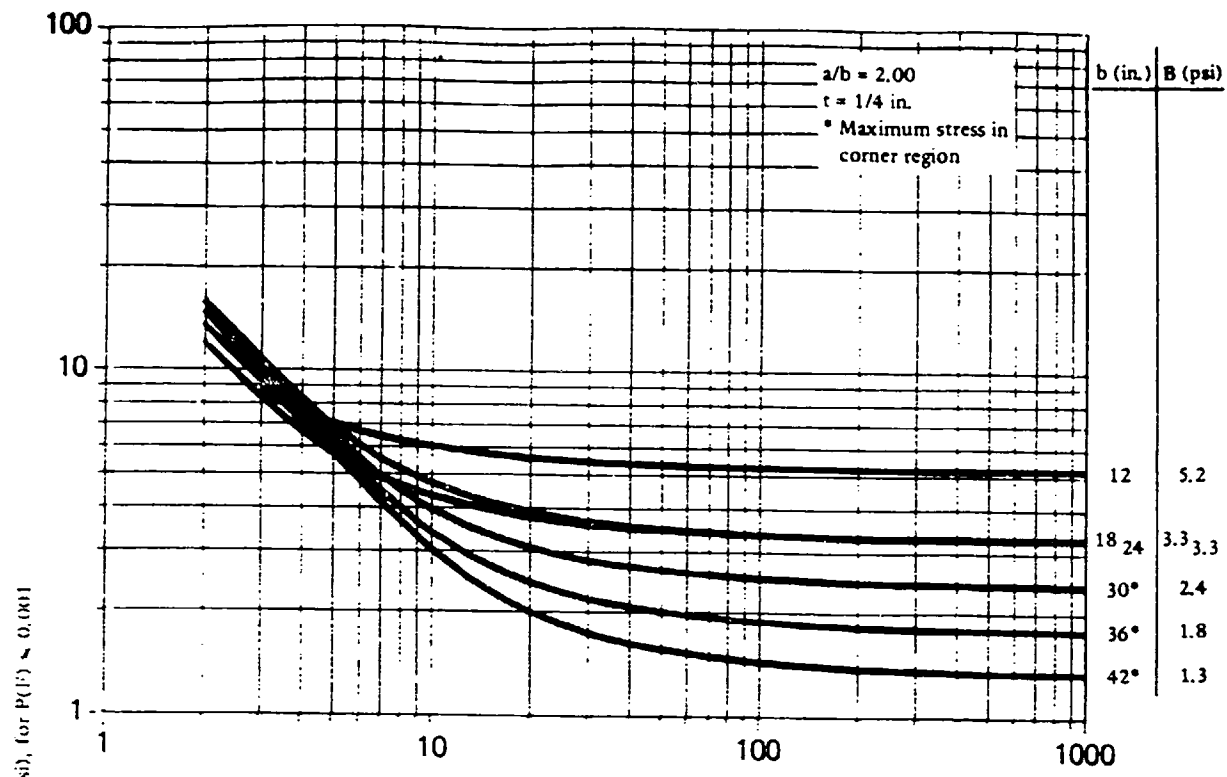

Figure 11. Peak blast pressure capacity for tempered glass panes: $a/b = 2.00$, $t = 1/4$ and $3/16$ in.

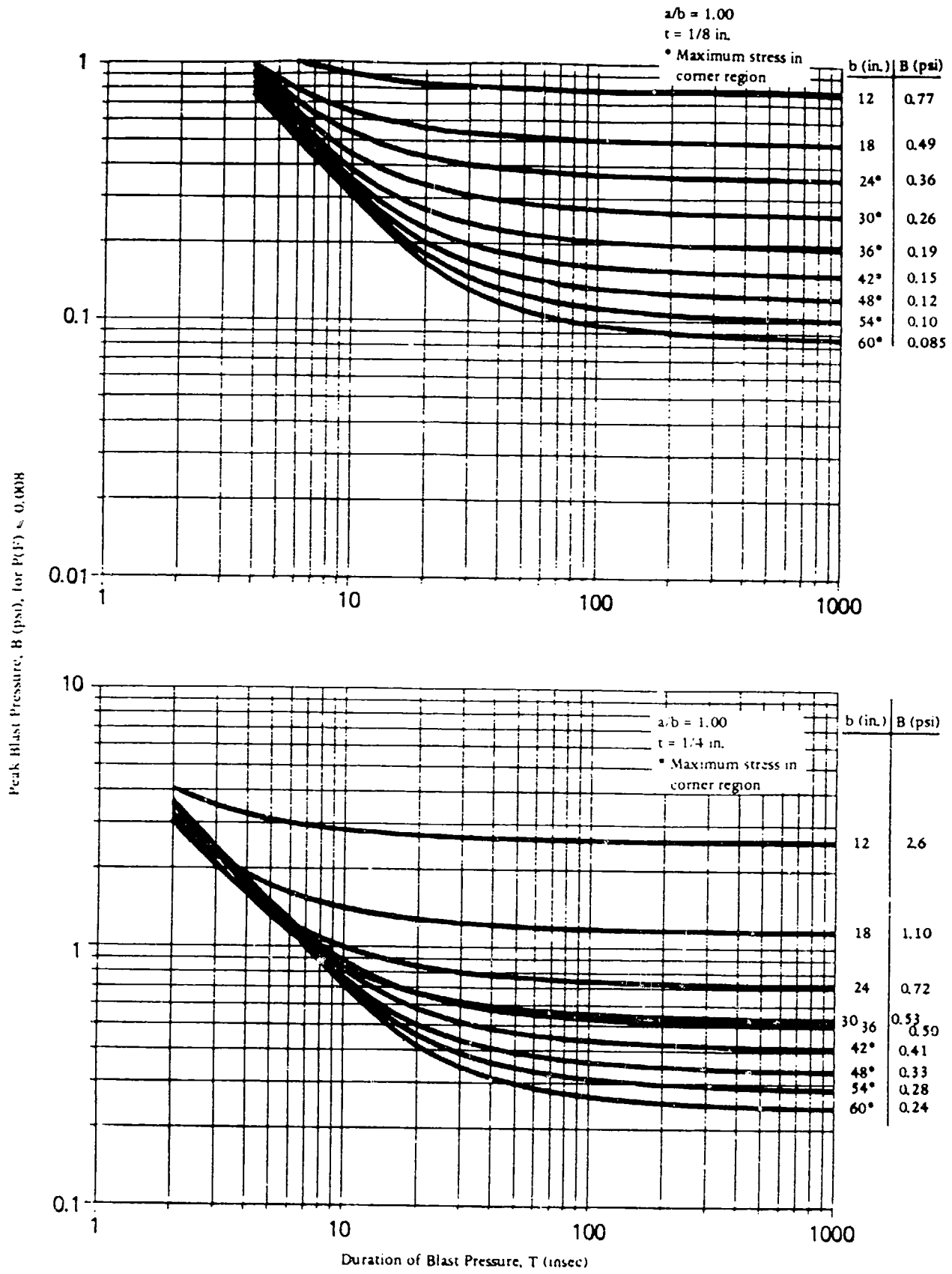

Figure 12. Peak blast pressure capacity for annealed glass panes: $a/b = 1.00$, $t = 1/8$ and $1/4$ in.

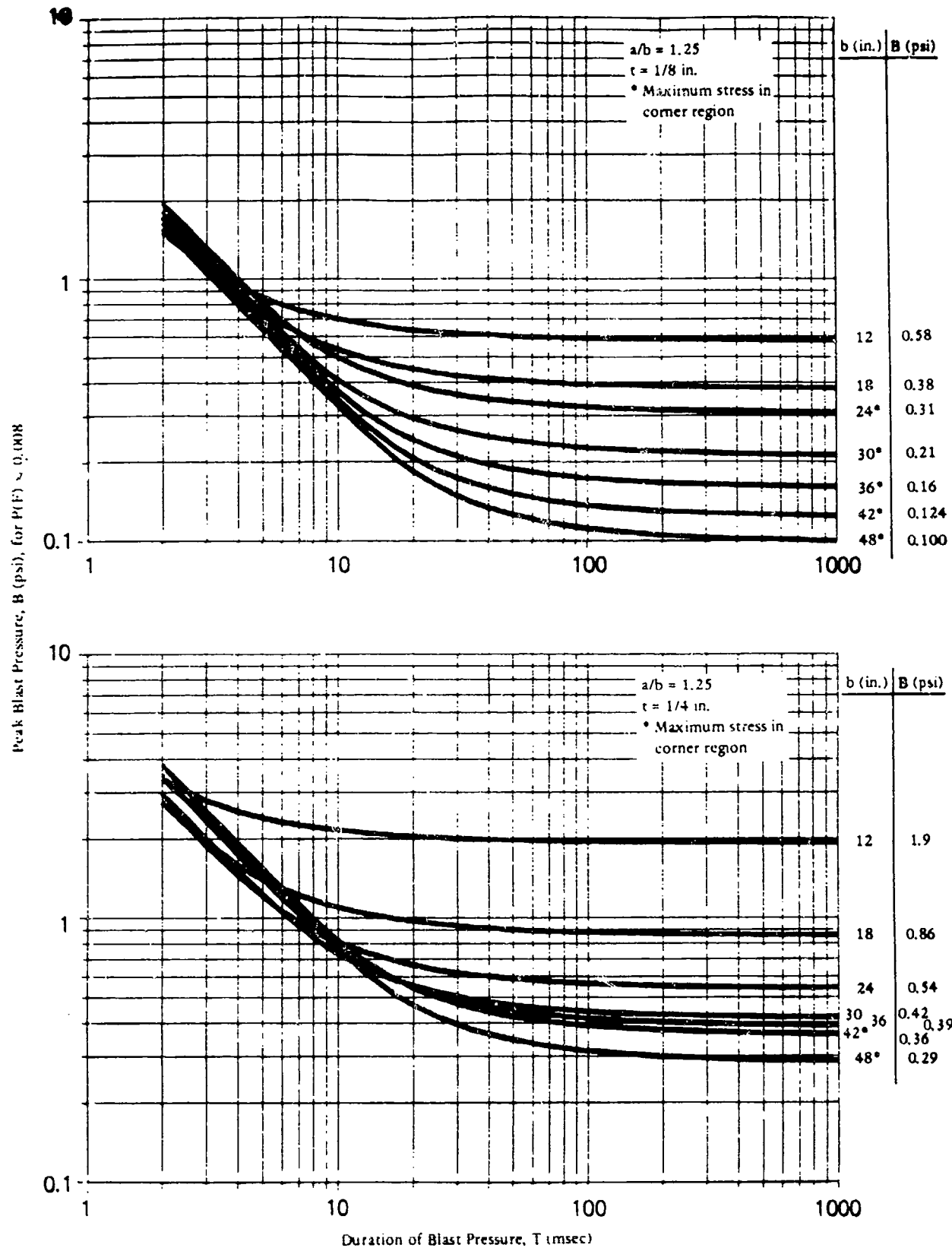

Figure 13. Peak blast pressure capacity for annealed glass panes: $a/b = 1.25$, $t = 1/8$ and $1/4$ in.

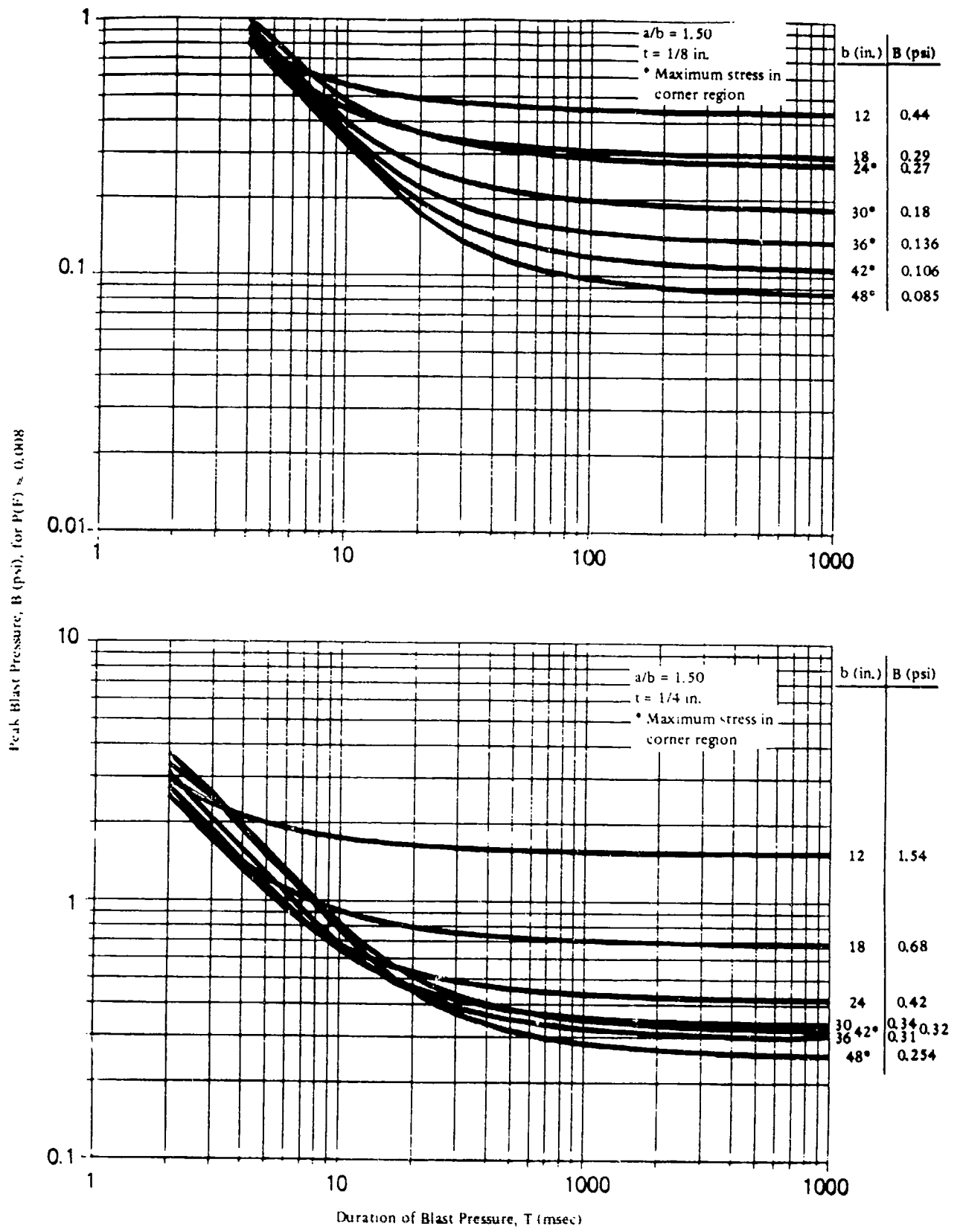

Figure 14. Peak blast pressure capacity for annealed glass panes. $a/b = 1.50$, $t = 1/8$ and $1/4$ in.

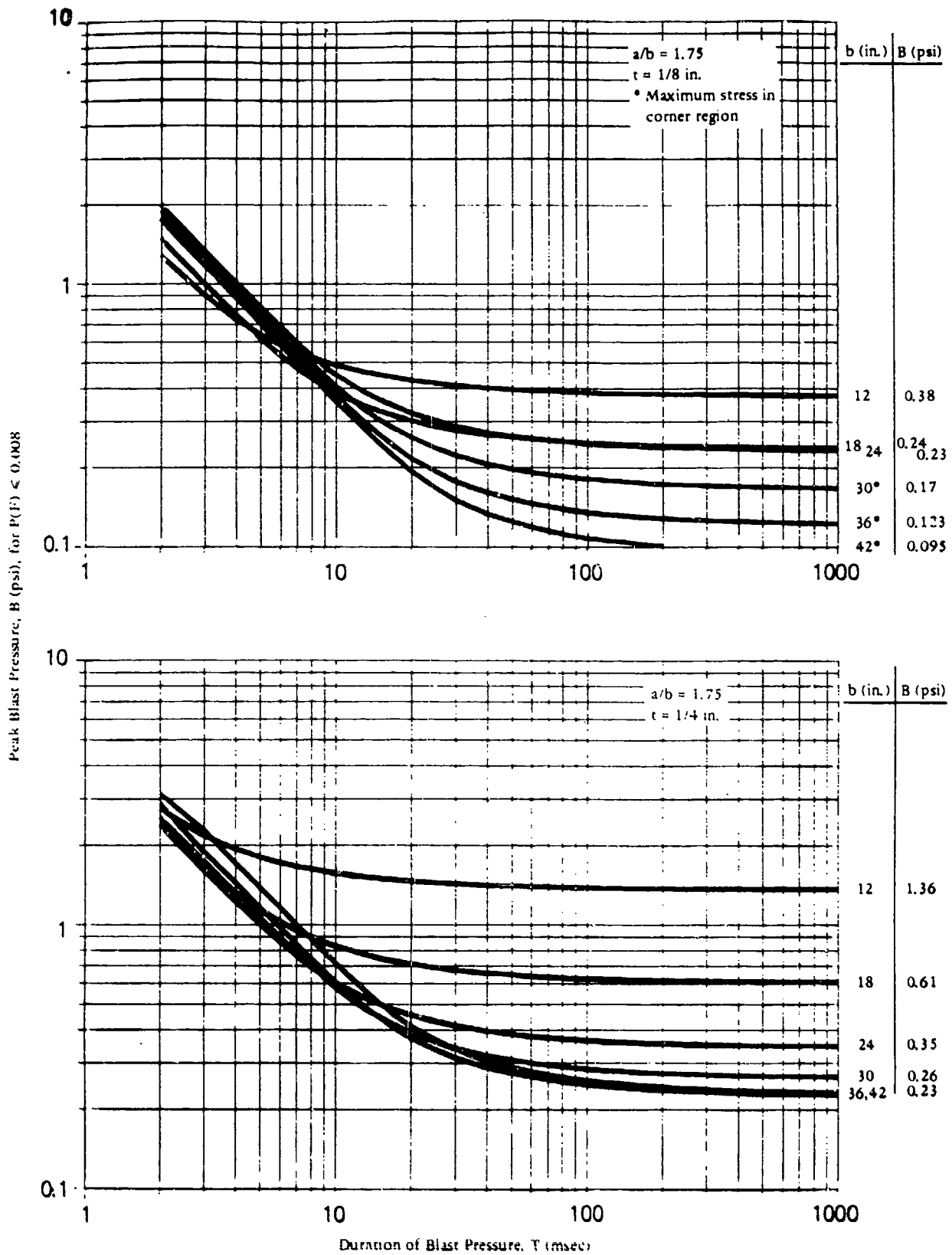

Figure 15. Peak blast pressure capacity for annealed glass panes: $a/b = 1.75$, $t = 1/8$ and $1/4$ in.

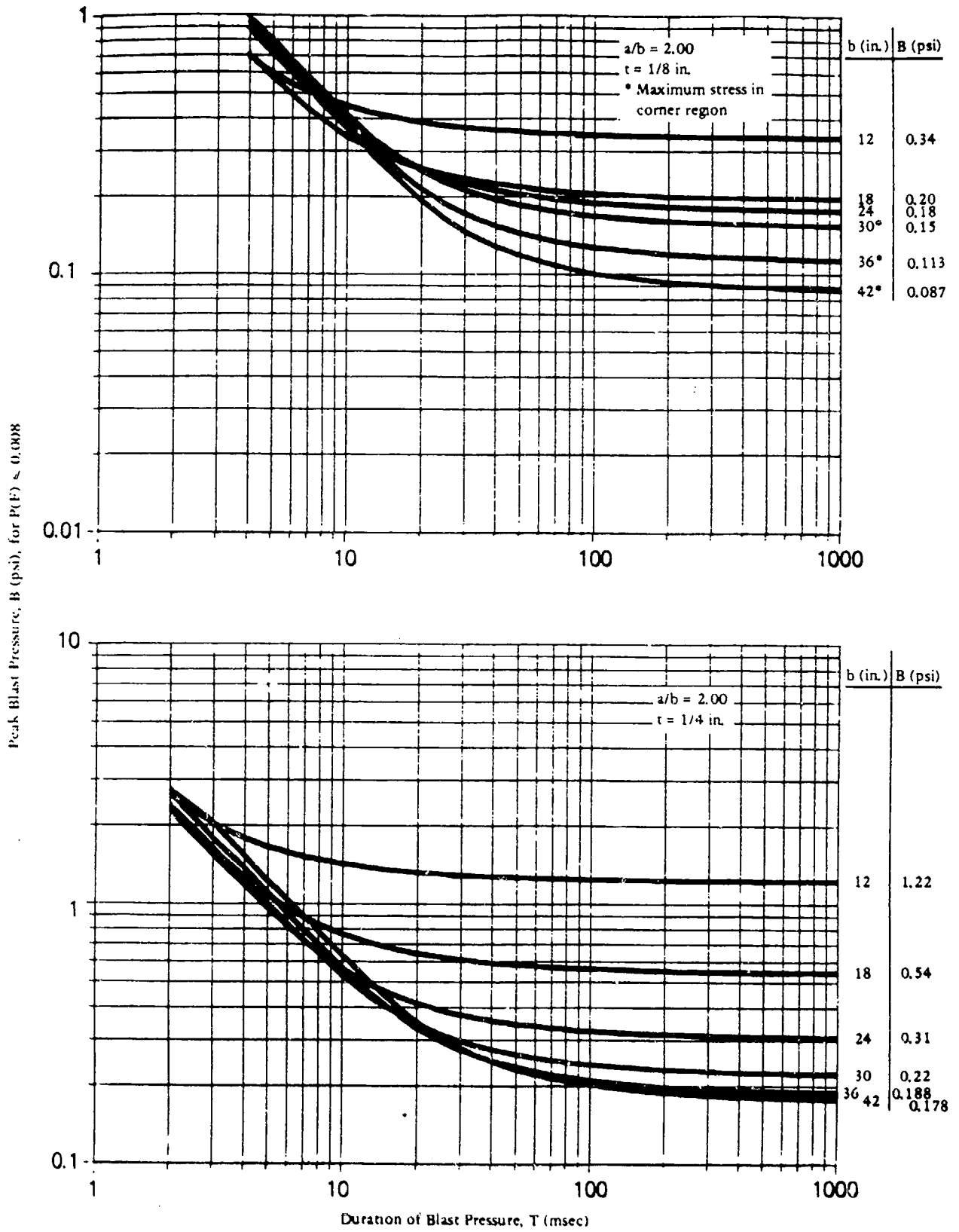

Figure 16. Peak blast pressure capacity for annealed glass panes: $a/b = 2.00$, $t = 1/8$ and $1/4$ in.

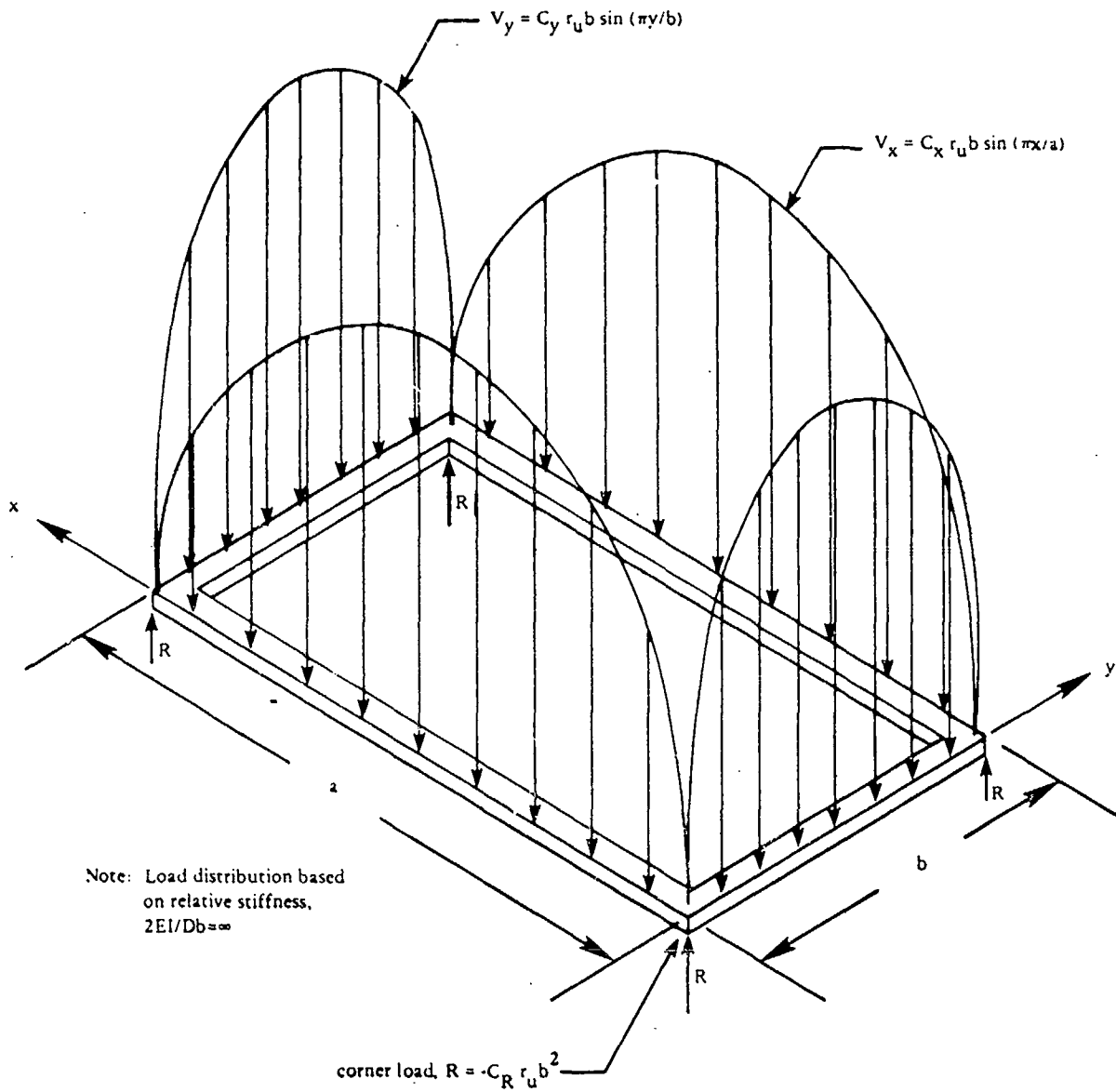

Figure 17. Distribution of lateral load transmitted by glass pane to the window frame.

Appendix A

COMMENTARY ON

DESIGN CRITERIA FOR BLAST RESISTANT WINDOWS

by

G. E. Meyers

INTRODUCTION

Presently, an adequate data base for the evaluation and validation of blast resistant window design criteria has yet to be developed. However, the proposed blast resistant window design criteria appear to be conservative when compared to the existing static uniform load and blast load data.

In FY85, the Naval Civil Engineering Laboratory (NCEL) plans static load validation tests on blast resistant windows. Blast load validation tests are also scheduled during FY85.

Static Ultimate Resistance

The resistance function utilized for the modeling blast capacity of windows is based upon a finite element solution of glass plates with realistic boundary conditions subjected to static uniform loads and large deflections. The relationship between the non-dimensional stress, non-dimensional center deflection and non-dimensional load are presented in Figures 1 and 2. The computer model developed to develop the blast resistant window design criteria digitized the resulting curves within its internal data base.

Table 1 presents a comparison between the measured and predicted capacities of glass panes tested. As a large sample of data is necessary for a meaningful comparison, the test data from ARRADCOM (Ref 2) should only be used for the purpose of orientation. For tests with a sufficient sample size, the mean failure load is reported. A Student's t distribution estimate of a probability of failure, $P(F)$, of 0.001 for Wilson's tempered glass test is reported in parentheses. A probability of failure $P(F)$ of 0.001 is assumed by the design criteria in predicting ultimate static uniform load strength of tempered glass. The Student's t distribution estimates of probability of failure, $P(F)$, of 0.008 for the

Bowles and Sugarman (Ref 3) annealed glass tests are also reported in parenthesis in Table 1. A probability of failure, $P(F)$, of 0.008 is assumed by the design criteria in predicting static uniform load strength of annealed glass. Both series of tests indicate that the predicted static design load, r_u , is reasonably conservative. The one exception, the 0.250-inch annealed glass plates tested by Bowles and Sugarman, exhibited a bimodal ultimate static load distribution instead of a bell-shaped distribution. It is reasonable to assume that this particular sample batch was not representative of the true population of glass.

The following considerations must be taken into account when analyzing Table 1. A maximum principle tensile stress level of 4,000 psi for annealed glass and 17,000 psi for tempered glass is assumed by the design criteria. These values lower bound the maximum stresses derived from a failure prediction model developed by Beason and Morgan (Ref 4). Environmental degradation of load-carrying ability from regular in-service use is assumed by the prediction model. In contrast to the prediction model, all the tested glass was probably new. Ratios of ultimate static uniform loads for new annealed glass, which has not yet accumulated an equivalent amount of weakening surface flaws, to in-service glass can be as high as two. Ratios of new to in-service tempered glass strength are not as well known, but are estimated to be closer to unity.

The predicted static uniform load also assumes the minimum thickness specified by Federal Specification DD-G-451d. The ARRADCOM and Wilson data in Table 1 are reported in nominal thickness. Most likely, the glass was of a thinner thickness within the prescribed tolerance. Thicknesses of 0.115, 0.219, and 0.355 (nominally 1/8, 1/4, and 3/8) inch were assumed for the purpose of prediction, respectively. As actual mean thicknesses were reported by Bowles and Sugarman, they were included in static uniform load prediction model.

Additionally, the predicted uniform static load assumes an approximation of an infinitely stiff simple support. Frame deformations can induce premature failures as evidenced in the ARRADCOM static load tests nos. 9, 10, and 11.

The design criteria assume a relatively short stress intensity duration of less than one second. As less ceramic fatigue is induced, a higher allowable maximum principle tensile stress for a given probability of failure can be assumed than for the standard one minute static load. However according to the glass industry (Ref 5), a maximum stress of 4,000 to 4,400 psi correlates with typical mean breaking stresses for annealed glass under a static load of one minute duration. As this is a similar magnitude of stress intensity duration as the static tests of Table 1, a rough equivalence of static load capacity should exist between the Bowles and Sugarman mean breaking loads and the predicted breaking loads correlated with a probability of failure, $P(F)$, of 0.008. If a reduction by a factor of two is applied to the Bowles and Sugarman data to account for environmental degradation, the predicted load values are all conservative.

The predicted value of the ultimate static uniform load for the tempered glass samples tested by Wilson (Ref 1) is limited to the uniform static load associated with a center deflection of ten times the glass thickness. This condition is imposed by the accuracy limits of the equations implicit in the finite element modeling. With this limit imposed, the maximum stress induced in the 48 inch by 48 inch by 1/4-inch tempered glass plates by 0.97 psi of static uniform load is 15,920 psi. If the deflection limit was relaxed and the failure stress, f_u , of 17,000 psi was allowed to govern, the predicted load capacity would be 1.05 psi with a center deflection of 1.29 inch which is 10.3 times the glass thickness.

Blast Load Capacity

The design criteria are compared to data from explosive load tests of both tempered and annealed glass in Table 2. As a large data base does not exist, the data should only be used for orientation. With this perspective in mind, no evidence of invalidation of the design criteria is apparent. As with the static uniform load tests, frame distortion will induce premature failure.

Blast load design predictions are also based upon a probability of failure, $P(F)$ of 0.001 for tempered glass and 0.008 for the analysis of annealed glass. Allowable maximum principle tensile stresses associated with the probability of failure are 17,000 psi for tempered glass and 4,000 for annealed glass. In-service strength degradation is assumed. In tests where the thickness is presented as a fraction, minimum thickness within prescribed federal tolerance is used for the design prediction. Where thickness is specified, interpolated results from the design charts or special computer runs of the design program are used to obtain predictions.

The blast load capacity design criteria assume that the glass has not been exposed to more than one explosive load. Because each large stress experience resulting from an explosive load will expand the microscopic flaw network or flaw web in the glass, the glass, in a probabilistic sense, will be weaker after each explosive episode. As most of the explosive glass tests in Table 2 are repeated until failure, an unspecified reduction in the survivable blast load is most likely exhibited by the test results.

REFERENCES

1. D.M. Moore. FSA task report no. 5101-291: Thickness sizing of glass plates subjected to pressure loading, Jet Propulsion Laboratory. Pasadena, Calif., Aug 1982.
2. S. Weissman, N. Dobbs, W. Stea, and P. Price. Blast capacity evaluation of glass windows and aluminum window frames, U.S. Army Armament Research and Development Command, ARLCO-CR-78016. Dover, N.J., Jun 1978.
3. R. Bowles and B. Sugarman. "The strength and deflection characteristics of large rectangular glass panels under uniform pressure," Glass Technology, vol 3, no. 5, Oct 1962, pp 156-171.

4. W.L. Beason and J.R. Morgan. "A glass failure prediction model", Journal of the Structural Division, vol 110, no. 2, American Society of Civil Engineers, Feb 1984.
5. PPG Industries. PPG TSR 101A. Pittsburgh, Pa.
6. Structural performance of glass in exterior windows, curtain walls, and doors under the influence of uniform static loads by destructive methods, American Society for Testing Materials, ASTM Standard (draft), draft of proposed standard by ASTM Committee E06.51. Philadelphia, Pa., Oct 1982.
7. W.J. Taylor and R.O. Clark. Shock tube tests of glazing materials, Ballistic Research Laboratories, Memorandum Report no. 626. Aberdeen Proving Ground, Md., Nov 1952.
8. E.R. Fletcher, D.R. Richmond and D.M. Richmond. "Airblast effects on windows in buildings and automobiles on the ESKIMO III Event," in Minutes of the Sixteenth Explosive Safety Seminar, Volume I, Washington D.C., Sep 1974. Department of Defense Explosive Safety Board.
9. A. Karlen. Shock wave test with window glass, Fortifikations forvaltningen, C-Report Number 133. Stockholm, Sweden, Feb 1976.

Table 1. Measured and Predicted Strength of Windows Subjected to a Static Uniform Load to Failure

Window				Samples Tested	Ultimate Strength, r_u			Comment	
a (in.)	b (in.)	a/b	t (in.)		Glass Type ^a	Measured (psi)	Predicted ^b (psi)		$\frac{r_u}{P_u}$ (measured) $\frac{r_u}{P_u}$ (predicted)
43.25	28.375	1.52	1/4 ^c	annealed	1	0.65	0.57	1.14	ARRADCOM static test no. 8. Glass breakage occurs in a wooden frame.
43.25	28.375	1.52	1/4 ^c	tempered	1	8.58	4.56	1.88	ARRADCOM static test no. 6. Glass breakage occurs in a wooden frame.
43.25	28.375	1.52	1/4 ^c	tempered	1	8.30	4.56	1.82	ARRADCOM static test no. 7. Glass breakage occurs in a wooden frame.
43.25	28.375	1.52	1/4 ^c	tempered	1	1.02	4.56	0.22	ARRADCOM static test no. 9. Frame bead failure induced premature failure.
43.25	28.375	1.52	1/4 ^c	tempered	1	2.23	4.56	0.49	ARRADCOM static test no. 10. Failure occurs due to deformation of strengthened aluminum frame.

continued

Table 1. Continued

Window				Samples Tested	Ultimate Strength, r_u		Comment		
a (in.)	b (in.)	a/b	t (in.)		Glass Type ^a	Measured (psi)		Predicted ^b (psi)	$\frac{r_u(\text{measured})}{r_u(\text{predicted})}$
43.25	28.375	1.52	1/4 ^c	1	tempered	4.43	4.56	0.97	ARRADCOM static test no. 11. Failure due to deformation of strengthened aluminum frame.
48	48	1	1/8 ^c	8	tempered	1.765 (1.21) ^d	0.97	1.82 (1.25) ^e	Wilson static load tests. Prediction is limited to test capacity of center deflection = 10 t.
40	40	1	0.122	40	annealed	0.754 (0.41) ^d	0.24	3.14 (1.71) ^e	Static testing by Bowles and Sugarman.
40	40	1	0.197	30	annealed	1.412 (0.77) ^d	0.54	2.61 (1.42) ^e	
40	40	1	0.250	30	annealed	1.811 (0.64) ^d	0.78	2.32 (0.82) ^e	
40	40	1	0.373	30	annealed	3.625 (1.45) ^d	1.27	2.85 (1.14) ^e	

^aAll glass tested is new.

^bBased on $P(F) = 0.001$ for tempered glass at $f_u = 17,000$ psi and $P(F) = 0.008$ for annealed glass at $f_u = 4,000$ psi.

^cThickness reported in fractions are nominal thicknesses.

^dStatistical estimate of design probability of failure based on a Student's t distribution of test sample $P(F) = 0.001$ for tempered glass and $P(F) = 0.008$ for annealed glass.

^eRatio of statistical estimate of the design probability of failure of the test sample to the predicted strength.

Table 2. Measured and Predicted Dynamic Strength of Windows Subjected to Dynamic Blast Loads

Window				Blast Parameters		Design Prediction		Comments	
a (in.)	c (in.)	a/b	t (in.) ^a	Glass Type	B (psi)	T (msec)	B (psi)		T (msec)
43.25	28.375	1.52	1/4	tempered	4.4	45	3.6	45	ARRADCOM dynamic test no. 5, Series I. Glass fails after repeated loadings (Ref 2).
62.75	47.00	1.34	1/4	tempered	4.4	45	1.7	45	ARRADCOM dynamic test no. 5, Series I. Glass survived.
43.25	28.375	1.52	1/4	tempered	4.4	45	3.6	45	ARRADCOM dynamic test no. 5, Series I. Glass survived.
43.25	28.375	1.52	3/8	tempered	4.4	45	6.1	45	ARRADCOM dynamic test no. 5, Series I. Glass survived.
62.75	47.00	1.34	1/4	tempered	4.4	45	1.7	45	ARRADCOM dynamic test no. 5, Series I. Glass survived.
62.75	47.00	1.34	3/8	tempered	4.4	45	3.8	45	ARRADCOM dynamic test no. 5, Series I. Glass survived.
43.25	28.375	1.52	1/4	tempered	1.0	48	3.5	48	ARRADCOM test no. 1, Series II. Tempered glass in aluminum frame survived.
43.25	28.375	1.52	1/4	tempered	1.2	50	3.5	50	ARRADCOM test no. 2, Series II. Failure occurred due to frame distortion.
43.25	28.375	1.52	1/4	tempered	2.3	50	3.5	50	ARRADCOM test no. 3, Series II. Glass survived.

continued

Table 2. Continued

Window				Blast Parameters		Design Prediction		Comments	
a (in.)	c (in.)	a/b	t (in.) ^a	Glass Type	B (psi)	T (msec)	B (psi)		T (msec)
43.25	28.375	1.52	1/4	tempered	3.1	50	3.5	50	ARRADCOM test no. 4, Series II. Glass fails due to frame distortion.
43.25	28.375	1.52	1/4	annealed	0.78	44	0.42	44	ARRADCOM test no. 3, Series II. Glass survived.
62.75	47.00	1.34	1/4	annealed	0.78	44	0.36	44	ARRADCOM test no. 3, Series II. Glass failed.
62.75	47.00	1.34	1/4	annealed	0.31	43	0.36	43	ARRADCOM test no. 2, Series II. Glass survived.
35.85	35.85	1.00	1/8	annealed	0.58	60	0.21	60	DNA 5593T. Glass failed in a shock tube test (Ref 7).
48.00	34.00	1.40	0.236	annealed	1.00	250	0.37	250	ESKIMO III tests. Window survived (Ref 8).
45.00	45.00	1.00	0.232	annealed	1.00	260	0.37	260	ESKIMO III tests. Window failed.
42.00	20.00	2.10	0.124	annealed	1.00	260	0.47	260	ESKIMO III tests. Window failed.
53.54	37.80	1.41	0.157	annealed	2.9	10	0.56	10	Fortification directorate. Window survived (Ref 9).
53.54	37.80	1.41	0.157	annealed	5.0	10	0.56	10	Fortification directorate. Window failed.

^aThicknesses in fraction format are nominal inches.

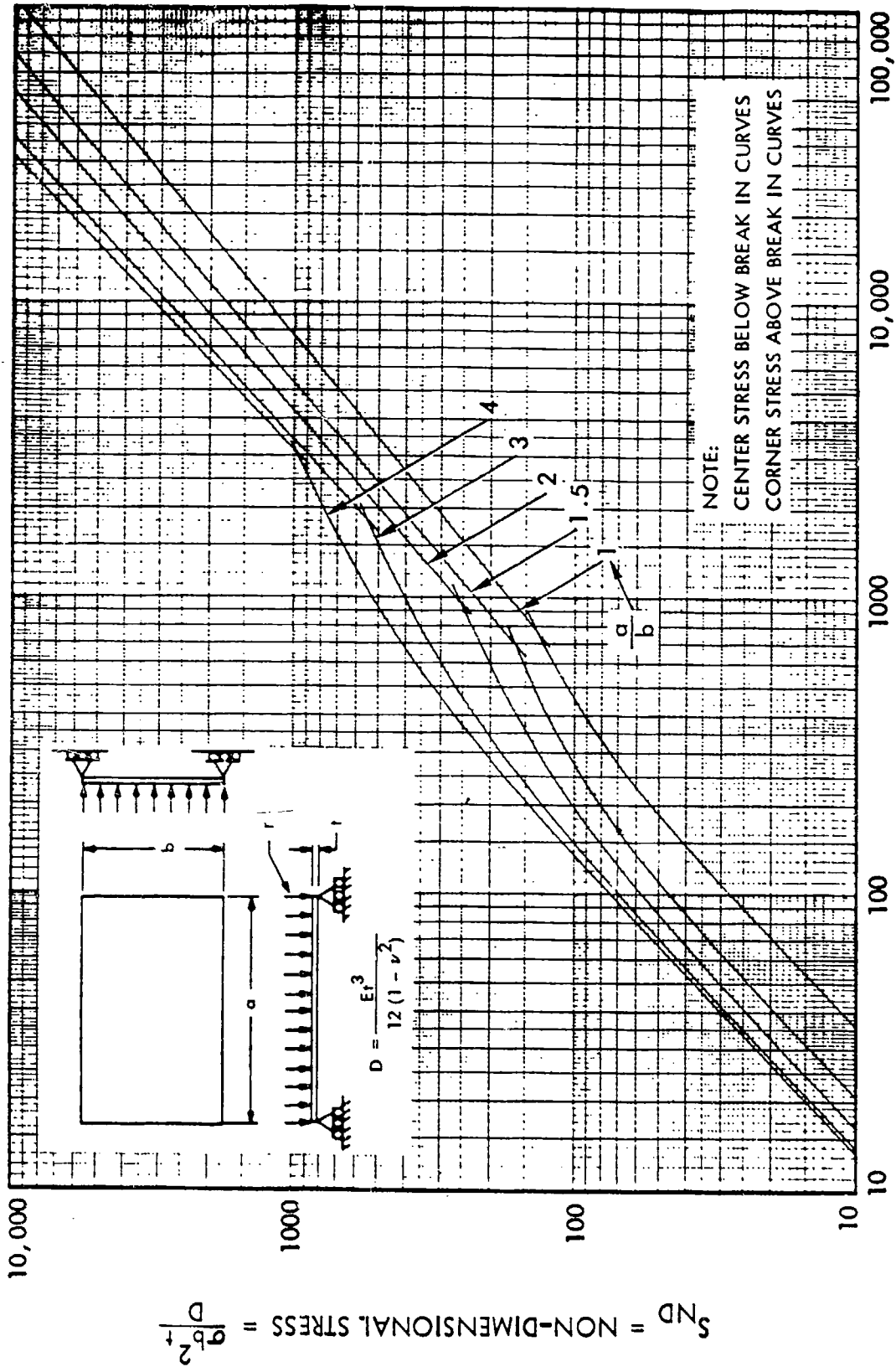

$$L_{ND} = \text{NON-DIMENSIONAL STATIC LOAD} = \frac{rb^4}{Dt}$$

Figure 1. Non-dimensional static load-stress relationships for simply supported plates

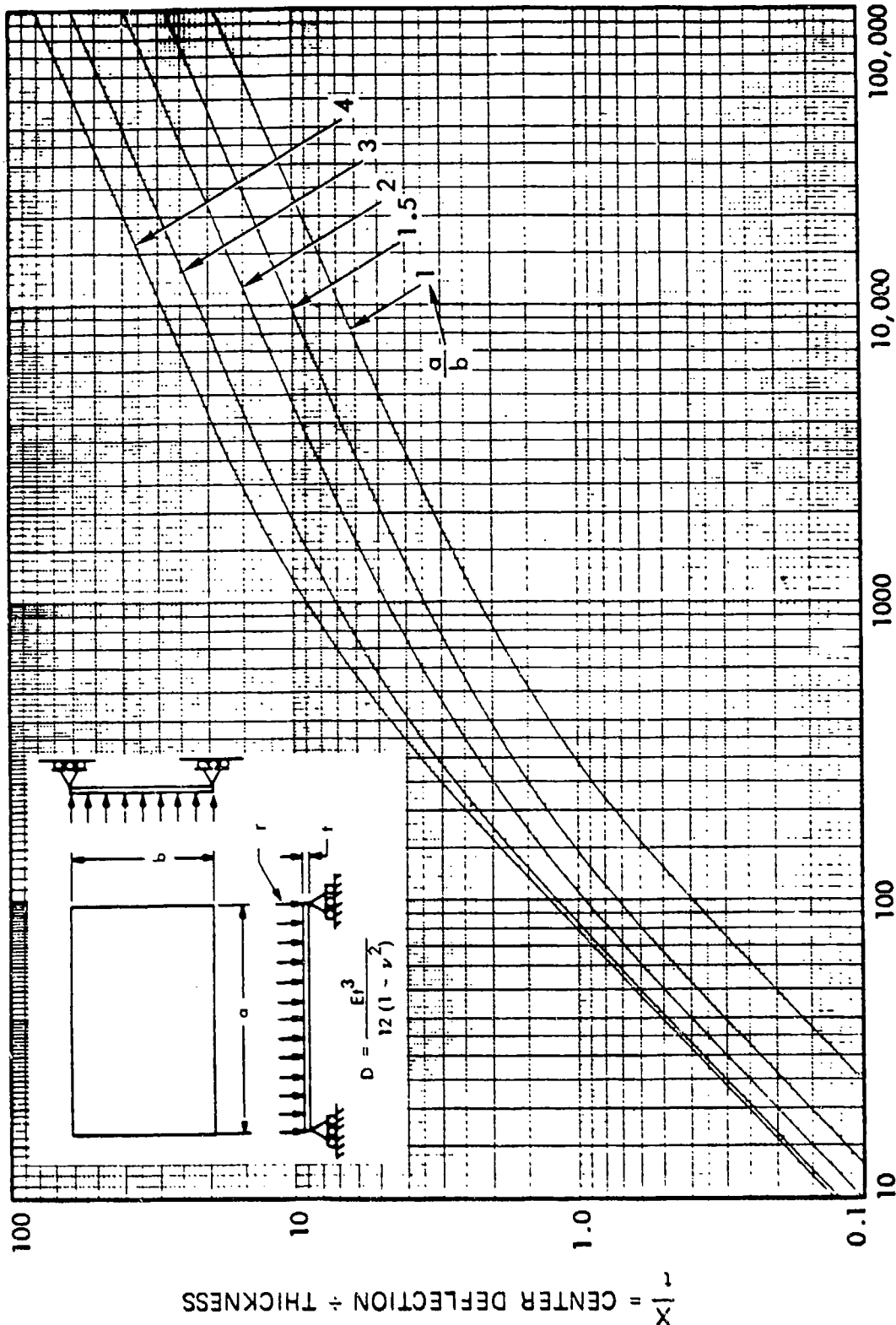

Figure 2. Non-dimensional static load-crater deflection relationships for simply supported plates