

COMPONENT PART NOTICE

THIS PAPER IS A COMPONENT PART OF THE FOLLOWING COMPILATION REPORT:

TITLE: Proceedings of the International Workshop/Symposium on Ice Drilling  
Technology (2nd) Held at Calgary, Alberta, Canada on 30-31 August 1982.

TO ORDER THE COMPLETE COMPILATION REPORT, USE AD-A156 733.

THE COMPONENT PART IS PROVIDED HERE TO ALLOW USERS ACCESS TO INDIVIDUALLY AUTHORED SECTIONS OF PROCEEDING, ANNALS, SYMPOSIA, ETC. HOWEVER, THE COMPONENT SHOULD BE CONSIDERED WITHIN THE CONTEXT OF THE OVERALL COMPILATION REPORT AND NOT AS A STAND-ALONE TECHNICAL REPORT.

THE FOLLOWING COMPONENT PART NUMBERS COMPRISE THE COMPILATION REPORT:

AD#: P004 801 thru P004 820 AD#: \_\_\_\_\_  
AD#: \_\_\_\_\_ AD#: \_\_\_\_\_  
AD#: \_\_\_\_\_ AD#: \_\_\_\_\_

DTIC  
SELECTED  
S JUL 25 1985 D  
A

This document has been approved for public release and sale; its distribution is unlimited.

|                   |                                     |
|-------------------|-------------------------------------|
| Accession For     |                                     |
| NTIS GRA&I        | <input checked="" type="checkbox"/> |
| DTIC TAB          | <input type="checkbox"/>            |
| Unannounced       | <input type="checkbox"/>            |
| Justification     |                                     |
| By _____          |                                     |
| Institution _____ |                                     |
| Address _____     |                                     |
| City _____        |                                     |
| State _____       |                                     |
| Dist _____        |                                     |
| Special _____     |                                     |

A1

DTIC FORM 463  
MAR 85

OPI: DTIC-TID

## "CLIMATOPIC" THERMAL PROBE

F. Gillet, C. Rado, Laboratoire de Glaciologie  
 G. Marec, M. Maitre, et de Geophysique de l'Environnement  
 J. Perrin and G. Ricou C.N.R.S., Grenoble, France

## ABSTRACT

Stable isotope analysis of the melt water recovered by a thermal probe can give a continuous record of climatic changes. The "climatopic" probe has a small diameter (43 mm) and needs only low power (2250 W) on the head to reach practical drilling speeds usually lying between 5 and 8 m/h. With runs up to 6 m we hope to drill deeper than 3000 m in a single summer. Because of the limited power requirements, the necessary cable weighs only 1050 Kg and the overall equipment is relatively light (8000 Kg completely packed) and easy to transport. The amount of fluid needed for the hole is also limited to about 2.5 l/m.

6 m, we hope to drill deeper than 3000 m in a single summer season.

## EQUIPMENT

## Drill Unit

The drill has an outer diameter of 43 mm, weighs 45 Kg and is 15.6 m long. It is composed of five sections having the following lengths: Hot point (0.4 m); Pump end flow measurement section (0.7 m); Melt tank (10.10 m); Electronic end suspension (0.4 m) and the Cable termination section (0.4 m).

Two different types of hot point are used. The first one was developed for temperate glaciers. An insulated nickel-chrome wire is cast in pure silver. These hot points are very efficient and reliable but relatively expensive. We now use high power density certridges soldered in a copper cylinder (Taylor, 1976). Both types have a power rating of 2250 W at 320 V. To avoid any penetration of water, even under high pressures, a glass-metal sealing is soldered on the cold part of the heating element (Fig. 1).

Suction of melt water is made at 35 cm above the bottom of the hole by a vibration pump. The flow (20-30 l/h) is higher than the production of water (9-11 l/h) to be sure that all the water produced is pumped up. The power delivered to this pump section is high (400 W) and it is difficult to reduce it because of the circulation of cold fluid in the pipes and because we have to start the

## INTRODUCTION

After the successful drilling in 1977/78 at Dome C with the thermal core drill, it appeared that it was not possible to go deeper than 905 m in a dry hole. But before developing a deep core drill working in a fluid filled hole, we thought that a small diameter thermal probe, recovering melt water samples, would be an interesting development.

Stable isotope analyses of this water could provide a continuous record of climatic changes. The aim of the "climatopic" probe is to obtain this climatic record and also to measure, at a later stage, the temperatures in the hole.

Using hot points of the same type as those developed for temperate glaciers (Gillet, 1975) and making runs of up to

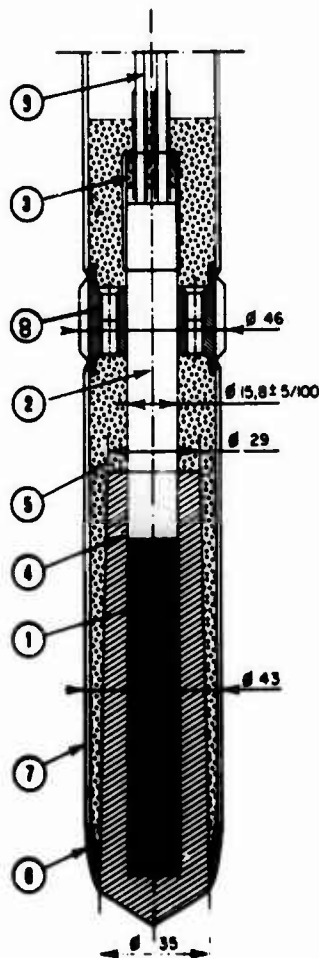

Figure 1. Cross section of the hot point. (1) High power density cartridge; element resistance =  $46 \Omega$ . (2) Cold part of cartridge. (3) Glass-metal sealing. (4) Copper cylinder brazed to cartridge. (5) Ceramic coating used as thermal insulation. (6) Stainless steel tip brazed onto the copper cylinder. (7) Stainless steel tube. (8) Cooling flange brazed onto the cartridge. The holes are used for setting the ceramic around the copper cylinder. (9) Copper wire used for power conductor.

circulation of water at low temperatures. The flow is measured by a special flow gage while a differential pressure gage indicates the water level in the tank.

The melt tank is made from two stainless steel tubes (40-43 mm diameter) screwed together. To avoid a full re-freezing of water, a heating wire located along the axis of the tube gives a power density of 35 W/m. This heat is not sufficient to prevent the formation

of a thick annulus of ice. After each run the tank must be placed in a heated enclosure before all the water is recovered. A floating piston gives an alarm signal when the tank is full.

In order to reduce the size of the cable, the telemetering system uses a bifilar line for four measurements: flow, water level, alarm and suspension. Four low frequency carriers are operated in frequency shift keying mode by four pulse code modulators. The transmitter is located in the upper part of the drill in a 3.5 m long steel tube with a thickness of 6 mm in order to resist the pressures encountered (Fig. 2).

The suspension of the drill on the cable is monitored by the elongation (5 cm) of a spring moving a magnet near a cell using the Hall Effect. Electrical insulation between armor and drill is provided by a Teflon cylinder.

#### Cable

The cable is 8.9 mm in diameter, is 4000 m long and weighs 1050 Kg. It consists of two outer layers of steel armor and four conductors: two  $0.93 \text{ mm}^2$  conductors used in parallel and the armor provide a 7 A RMS current path for the hot points. The surface voltage is about 900 V RMS; two  $0.34 \text{ mm}^2$  conductors are used for telemetering.

#### Power Supply

This unit supplies the 900 V, 7 A power. The voltage is obtained from a three phase 380 V generator by a specially designed inverter, the output voltage from which can be varied from 0 to 1000 volts.

#### Winch and Tower

The cable is spooled using the "Lebus" system on a Duraluminium drum connected by a chain drive to a gear reducer. A 12 KW, 3 phase, 380 V variable speed motor (120 - 2400 rpm) gives a maximum hoisting speed of 86 m/min. A disc brake is located between motor and gear reducer. For each run, a small hydraulic variable speed motor reducer connected to the main motor by an electromagnetic coupling gives a speed between 2 and 70 m/h. The mast is 11.4 m high and is made of two 250 mm diameter Duraluminium tubes. It is surrounded by four air heated polyethylene tubes designed to receive the melt tanks after each run for recover-

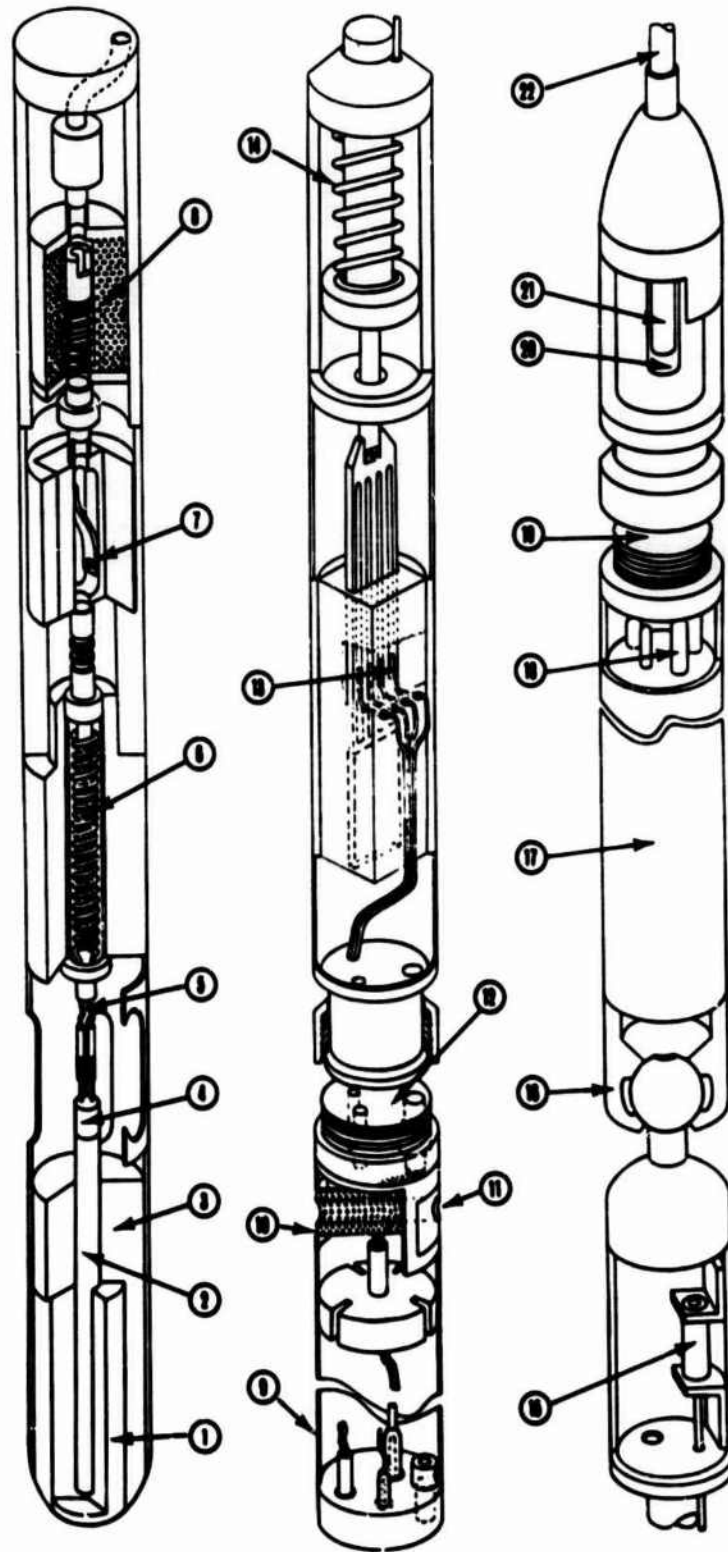

Figure 2. Schematic diagram of the "climatopic" probe. (1) Copper cylinder. (2) Heating cartridge. (3) Thermal insulation. (4) Glass metal sealing. (5) Water suction pipe. (6) Heating wire. (7) Flow gage. (8) Vibration pump. (9) Melt tank. (10) Filter. (11) Drain hole. (12) Connection. (13) Linear slip ring. (14) Suspension spring. (15) Linear transducer. (16) Ball and socket joint. (17) Electronic section. (18) Electrical connections. (19) Connector. (20) Teflon tube for electrical insulation. (21) Cerromatrix cable termination. (22) Armored cable.



Figure 3. General view of the equipment: Inverter (left); Control consol (middle); Winch platform with tower (right).

ing the water.

At the top, the pulley is equipped with a pulse generator (200 pulses per revolution) connected to a counter for determining the depth of the drill in the bore hole.

#### RESULTS OBTAINED

The drill was tested during the 1981/82 austral summer, at Dome C. Starting from the 180 m hole made in 1978/79 we drilled to 235 m. For the first 28 m we had a penetration rate of up to 5 m/h. This figure is lower than the figures obtained in laboratory tests (8 m/h), and could be partially explained by impurities encountered at the bottom of the hole. To avoid any loss of fluid in the permeable firn, we had installed a 130 m polyethylene tube casing in the hole. With the passage of the drill, small chips of polyethylene were torn off. These particles collected at the base of the hole. The hole then had to be cleaned by coring with a small electro-mechanical drill designed for that purpose as well as for the recovery of small ice cores.

The length of the runs, which is an important parameter for deep drilling, was no more than 4.6 m. This was due to the frequent trouble we had at the beginning with the flow measuring device and with the re-freezing of water in the

melt tank. The flow gage was mounted in a Teflon unit and with the low temperatures, we experienced problems with a reproducible positioning of the sensor.

On the other hand, the viscosity of water at +20°C is very different from the viscosity of DFA at -50°C, giving large variations in the flow. We needed some time to become familiar with these different values.

From 208 m to 217 m it became increasingly more difficult to penetrate the ice. We observed an increasing friction of the drill against the wall of the hole and at 217 m it was not possible to penetrate further. We explain this problem as follows.

The recovery of water in the melt tank set in a vertical position in the heated polyethylene tubes was not satisfactory. With an initial temperature of +80°C, the final temperature at the top could not be higher than +15°C and in adverse weather conditions it could be as low as -15°C. The tanks therefore had to be placed in a shelter after each run. The strength of the stainless steel tubes was not high enough, and after a few days of such handling, they became permanently deformed, making it impossible for the drill to pass along the bore hole. Because the bulk of the weight of the drill is located in the upper section (due mainly to the thick electronic tube)

it is not easy to obtain a vertical hole even if the drill is kept carefully in suspension. As the electronic tube is rigid, it probably had difficulty in following the bending radius of the hole without considerable frictional drag. This problem was the main one encountered during the operation. It can be solved by increasing the strength and rigidity of the tubes and by providing an articulation unit below the electronic section.

At 217 m we decided to ream the hole. Restarting from 207 m we advanced very slowly (0.5 to 1.0 m/h) in order to obtain a convenient hole diameter. Friction was immediately reduced and at 220 m we could increase the penetration rate to 2 m/h keeping friction to reasonable levels.

At this depth, we had solved the other problems previously observed concerning mainly hot points, the pump, flow measurement, and the heating of pipes. Then, we could get regular runs and reproducible figures before total refreezing of water in the tank. Usually the drilling would occupy about 45 minutes. This figure is appropriate if the penetration rate is 8 m/h. It could be slightly increased by a better heating of the lower part of the tank.

At 5 m/h we obtained 10 l/h of water. The water level in the tank was not measured because of a breakdown of the differential pressure gage, which was not suited to these working conditions. A better separation between water and DFA must also be achieved.

#### ELECTRO-MECHANICAL DRILL

With an OD of 43 mm and a length of 3 m, this small drill is designed to produce cores up to 50 cm long. A 2 Nm torque at 93 RPM is provided by a 115 V DC motor reducer. The chips are circulated by a turbine pump operated by a 75 V DC motor and stored in a special filter compartment.

This drill was designed to be used periodically in conjunction with the main climatopic probe. In this way, ice core may be obtained at desired depths.

This drill worked without any major problems, but the core length must be increased from the present 20 cm.

#### LOGISTICS

The equipment, including the generator, weighs 8000 Kg in packing cases.

To this must be added the DFA needed for the generator (about 4 l/h) and the drilling fluid (about 2.5 l/m). This fluid is a mixture of DFA and Freon (F 11).

#### ACKNOWLEDGMENTS

We would like to thank the U.S. National Science Foundation for its essential logistical support in the field at Dome C. We also thank the Terres Australes et Antarctiques Françaises and the Expéditions Polaires Françaises for their financial and logistical support.

#### REFERENCES

- Gillet, F. (1975) Steam, hot water and electrical thermal drills for temperate glaciers. *Journal of Glaciology*, vol. 14, no. 70, p. 171-179.
- Taylor, P.L. (1976) Solid-nose and coring thermal drills for temperate ice. In *Ice Core Drilling*. Editor: J. Splettstoesser. Univ. of Nebraska Press. p. 167-177.

