

**Best Available
Copy
for all Pictures**

AN ALL TERRAIN VEHICLE EQUIPPED WITH CTIS

AWATIF E. HASSAN

NORTH CAROLINA STATE UNIVERSITY, RALEIGH, NORTH CAROLINA, USA

ABSTRACT

An all terrain vehicle designed and developed at North Carolina State University in 1980 was modified to incorporate a central tire inflation system (CTIS) composed of an air compressor, solenoid valves and controls to provide the proper air inflation pressure to the powered wheels. A radar unit for ground speed/slip measurements was employed to detect the vehicle mobility. The unit's slip data were erratic and could not be recommended for automatic control of the tire inflation pressure. Conversely, the radar ground speed outputs were within $\pm 2\%$ of the actual measured speeds and will be used in future circuitry control of the CTIS.

INTRODUCTION

Performance of off-road vehicles, such as skidders and tractors, depends on their flotation which is dependent on tire size and inflation pressure. Resistance to motion and vehicle mobility are usually affected by wheel sinkage and tire contact areas (footprints) which in turn affect rolling resistance and tractive effort. Kaczmarek (1981) reported that the footprint of the ZIL-157 military vehicle increased from 0.04 to 0.092 m² when the tire inflation pressure was reduced from 294 to 55 kPa under a constant loading condition.

The use of a central tire inflation system (CTIS) has been limited to military vehicles (Czako, 1974) and has been widely used in the USSR and Eastern Europe since World War II. All air systems used on these vehicles are manually controlled from the cab by the vehicle operator. Czako (1974) listed 31 models using central tire inflation systems developed by six nations from 1942-1970. Of these 31 vehicles, 19 are production and 12 prototype/experimental models. There is no production vehicle in the U.S.A. while the USSR has 12 models. The internal axle slip ring commonly used on the production vehicles to allow the compressed air to enter and leave the tires was designed and developed by the U.S. Army on the M54, 5-ton experimental truck.

In agriculture, tire inflation pressure has been one of the most important factors affecting motion resistance and tire performance. Zombori (1967) reported a significant increase in tractive power efficiency as a result of a reduction in inflation pressure of tractor tires at constant drawbar pull. The same results were demonstrated in Czako's study (1974) on military vehicles where a definite increase in vehicle mobility and drawbar pull was achieved with central tire inflation reduction from 240 to 103 kPa on loam soil.

AD-P004 398

Burt and Bailey (1982) reported an improvement in the tractive efficiency of a powered radial tire equipped with a CTIS, operating under controlled soil bin conditions, by the selection of appropriate levels of inflation pressure and dynamic load. They also concluded that net traction in future field applications can be improved with automatic control of inflation pressure of tires and dynamic loads on wheel axles for constant travel reduction ratio under varied soil conditions.

Grevis-James and Bloome (1982) developed and tested a tractor power monitor to measure ground speed, wheel slip, and drawbar pull using two magnetic pickups for ground and wheel speeds and a strain-gauge drawbar dynamometer. A fifth wheel unit was used to measure ground speed on the four-wheel tractor which might not be applicable under forestry conditions. The use of a radar unit for ground speed measurements eliminates the fifth wheel and is very attractive in field application. Many radar units are equipped with sensors to detect ground speed as well as slip (Tsuha, et al, 1982, Richardson, et al, 1982). Under laboratory conditions, Tsuha, et al, reported that the accuracy of the ground speed measurements using radar units was +5%. Several tractor performance monitors using radar based true ground speed sensors for agriculture and off-highway equipment are available on the market for installation on vehicles to monitor field performance and production.

The great variability in the road/terrain conditions represents the main difficulty in the use of manually operated central tire inflation/ground speed control systems. Several questions are in order:

1. How does the operator know that the tire pressure needs adjustment?
2. How can he interpret the control console readings from the radar ground speed sensor to inflation pressure alteration?
3. How does the operator know to what extent and in what direction the pressure should be adjusted?
4. How often and how fast can the operator respond to terrain variation in a certain time interval?

A logical answer to all these questions leads to the need for full automatic control of the central tire inflation pressure system using various sensors. Therefore, the ultimate goal of this research program is to develop an automatic central tire inflation system to assure vehicle mobility under various forestry terrain/soil conditions. However, the main objectives of this paper are to present an all terrain vehicle equipped with a CTIS, to discuss the various means and sensors for automatic control of tire inflation pressure, and to present the results of field evaluation studies using different tire inflation pressures.

DESIGN OF THE ATV

Site Characteristics

The forestry environment includes many extremes. One of the more severe of these extremes is wet sites that have been bedded in preparation for tree planting (Hassan, 1978). Figure 1 shows soil strength and

Unclassified

SECURITY CLASSIFICATION OF THIS PAGE (When Data Entered)

REPORT DOCUMENTATION PAGE		READ INSTRUCTIONS BEFORE COMPLETING FORM
1. REPORT NUMBER	2. GOVT ACCESSION NO.	3. RECIPIENT'S CATALOG NUMBER
4. TITLE (and Subtitle) PROCEEDINGS: 8th INTERNATIONAL CONFERENCE INT. SOC. FOR TERRAIN VEHICLE SYSTEMS		5. TYPE OF REPORT & PERIOD COVERED FINAL MAY - AUG 1984
7. AUTHOR(s) ED: MICHAEL J. DWYER		8. CONTRACT OR GRANT NUMBER(s) DAJA45-84-M-0251
9. PERFORMING ORGANIZATION NAME AND ADDRESS INT. SOC. FOR TERRAIN VEHICLE SYSTEMS NIAE, WREST PARK, SILSOE BEDFORD MK45 4HS, U.K.		10. PROGRAM ELEMENT, PROJECT, TASK AREA & WORK UNIT NUMBERS 61102A-It161102-BH57-01
11. CONTROLLING OFFICE NAME AND ADDRESS USARDSG-UK PO Box 65 FPO NY, NY 09510-1000		12. REPORT DATE AUG 84
14. MONITORING AGENCY NAME & ADDRESS (if different from Controlling Office)		13. NUMBER OF PAGES 1304 (3 vols)
		15. SECURITY CLASS. (of this report) Unclassified
		15a. DECLASSIFICATION/DOWNGRADING SCHEDULE
16. DISTRIBUTION STATEMENT (of this Report) Approved for public release; distribution unlimited.		
17. DISTRIBUTION STATEMENT (of the abstract entered in Block 20, if different from Report)		
18. SUPPLEMENTARY NOTES		
19. KEY WORDS (Continue on reverse side if necessary and identify by block number) MOBILITY; CROSS-COUNTRY MOBILITY; OFF-ROAD MOBILITY; SOIL-VEHICLE INTERACTION; VEHICLE DYNAMICS. ←		
20. ABSTRACT (Continue on reverse side if necessary and identify by block number) → The three volumes consist of a collection of all significant papers presented at the 8th International Conference. Subjects include; Tyre-soil interaction; theoretical aspects of ride dynamics; track-soil interaction; practical aspects of ride dynamics; operation in paddy fields; operation on steep slopes; soil compaction; steering; computer modelling; vehicle component design; measurement of soil and snow properties and soil bin facilities; and vehicle design. → cont. keywords include:		

DD FORM 1 JAN 73 1473 EDITION OF 1 NOV 65 IS OBSOLETE

Unclassified
SECURITY CLASSIFICATION OF THIS PAGE (When Data Entered)

REPRODUCED AT GOVERNMENT EXPENSE

COMPONENT PART NOTICE

THIS PAPER IS A COMPONENT PART OF THE FOLLOWING COMPILATION REPORT:

(TITLE): Proceedings of the International Conference on the Performance
of Off-Road Vehicles and Machines (8th). Volume 3.
Held at Cambridge, England, on August 5-11, 1984

(SOURCE): _____

TO ORDER THE COMPLETE COMPILATION REPORT USE AD A157 653.

THE COMPONENT PART IS PROVIDED HERE TO ALLOW USERS ACCESS TO INDIVIDUALLY AUTHORED SECTIONS OF PROCEEDINGS, ANNALS, SYMPOSIA, ETC. HOWEVER, THE COMPONENT SHOULD BE CONSIDERED WITHIN THE CONTEXT OF THE OVERALL COMPILATION REPORT AND NOT AS A STAND-ALONE TECHNICAL REPORT.

~~THE FOLLOWING COMPONENT PART NUMBERS COMPRISE THE COMPILATION REPORT:~~

~~ADN~~ TITLE:

Accession For	
NTIS GRA&I	<input checked="" type="checkbox"/>
DTIC TAB	<input type="checkbox"/>
Unannounced	<input type="checkbox"/>
Justification	
By _____	
Distribution/	
Availability Codes	
Dist	Avail and/or Special
A-1	

This document has been approved for public release and sale; its distribution is unlimited.

REPRODUCED AT GOVERNMENT EXPENSE

COMPONENT PART NOTICE (CON'T)

AD#:

TITLE:

a typical bed profile in the Coastal Plain region of North Carolina. Soil strength is very low and hence requires a low ground pressure vehicle for tree planting and subsequent forest operations. The use of a trailed planter on these sites requires at least a minimum of a 45-kW crawler tractor which tracks to either side of the bed causing clearance and bogging problems and resulting in losses in machine productivity.

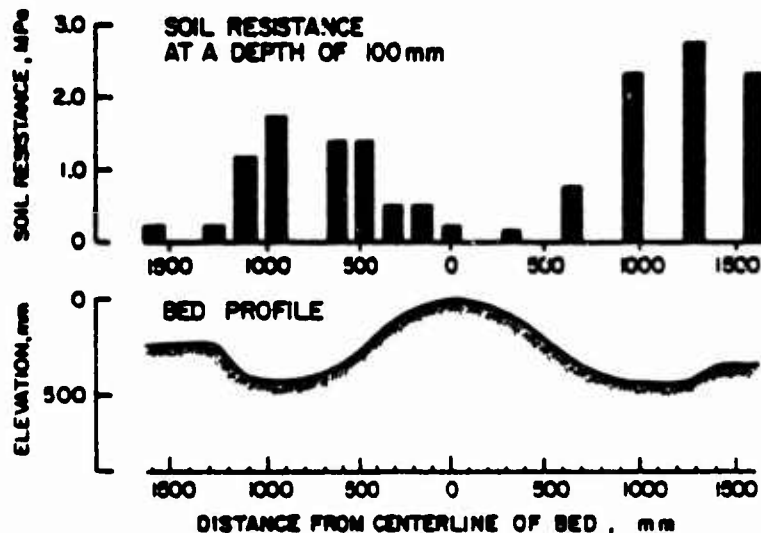

FIG. 1. Profile and soil strength measurements of a typical bed prepared by a bedding plow without packer drum.

Basic Design of the ATV

The above limitations and other considerations led to the development of a light-weight, all terrain vehicle (Fig. 2) at North Carolina State University in 1980 (Hassan and Whitfield, 1982). The ATV is equipped with a 12 kW, air-cooled engine, hydrostatic transmission and terra tires.

Field Testing and Evaluation

The ATV was operated on various beds of histosol soils in the Hofmann Forest, Maysville, N.C. and on oxisol soils of Federal Paper Board Co., Inc. at Lumberton, North Carolina. The vehicle proved to be adequately powered and displayed good maneuverability and stability.

A traction (pull) test of the ATV was conducted on a bedded site and a dirt road at Lumberton, where the load was applied by a skid pan and was increased by adding dead weights to the pan. The line pull was measured by a hydraulic dynamometer. For each load, advance and time per five revolutions for each of the two powered wheels were recorded to determine the travel reduction and ATV forward speed. The average moisture contents on a dry weight basis of the bedded site and the road were 80% and 20% respectively. The pull-travel reduction curves for this test are shown in Fig. 3 for a tire inflation pressure of 42 kPa. A total of 1000 N pull was available at 15 percent travel reduction on the bedded site. This



FIG. 2. The ATV with A-frame suspension is shown operating on a bedded site at the Hofmann Forest, N.C. - May 1980.

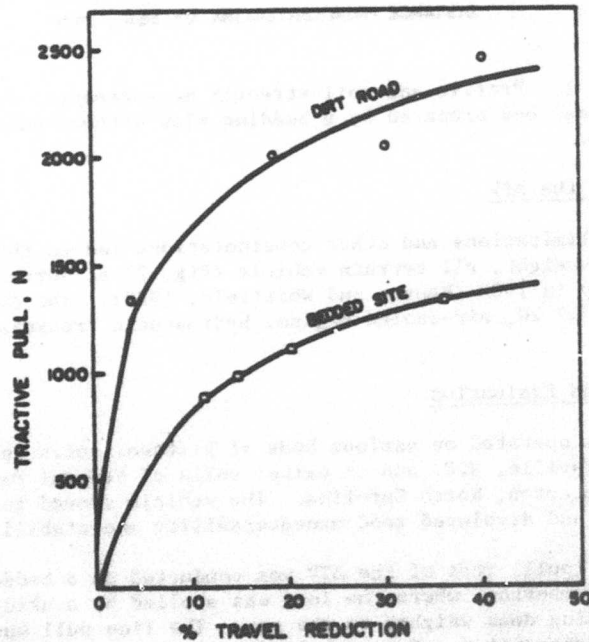

FIG. 3. Tractive pull-travel reduction curves for the bedded site and dirt road at Lumberton, N.C., May 1980.

pull force should be sufficient for light forestry operations. The results of the pull test also indicated that the overall tractive power efficiency of the ATV was only 25% at a ground speed of 5.4 km/h.

The control mechanism for the hydraulic pumps allowed the driver to turn easily and control the speed of the vehicle. Total mass of the vehicle and two operators, one driver and one instrument reader, was 692 kg. The mass distribution was 78% on the front drive wheels and 22% on the rear caster wheels. However, on rough terrain, the caster wheels tended to lose contact with the ground and swirl which caused excessive drag and lateral rear-end swings. This phenomenon was most evident when the ATV was attempting to travel across the beds. By increasing the trailing angle of the rear wheels, this problem was eliminated except in very rough terrain.

The suspension system on the front wheels of the vehicle was helpful in maintaining wheel to ground contact, but the suspension A-frame caused clearance problems in some instances. Stiffer springs than those on the machine should allow for more equal movement of the suspension frame above and below its static no-load position.

CENTRAL TIRE INFLATION SYSTEM

Physical Parameters of the ATV

The use of skidder tires or similar large size tires was not possible due to the large volume of air to be controlled or to the need to redesign the tire so that a small portion of its volume would be controllable.

The results of field testing of the ATV in North Carolina in 1980 indicated that the light weight vehicle, when properly designed, should be suitable for forestry applications and suggested further development, (Hassan and Whitfield, 1982). Therefore, it was decided to use the ATV in the development of an automatically controlled CTIS suitable for off-road vehicles. The original design of the ATV was limited to a total mass of 692 kg. The addition of the CTIS and radar unit increased the vehicle mass to 860 kg (Fig. 4) with weight distribution of 74 and 26 percent on the front and rear axles respectively. The front axle springs were strengthened to accommodate the additional weight. The caster rear wheel inflation pressure was maintained constant at 48kPa throughout the entire study.

Central Tire Inflation Pressure Circuit

The ATV tire inflation system circuit shown in Fig. 5 is composed of two normally closed solenoid valves for inflating and deflating the air pressure of the front powered tires. A portable compressor equipped with a 3-kW gas engine supplies compressed air at 670 kPa. When air is to be added to the tire, the inflation solenoid valve is activated, and subsequently air flows from the compressor tank through the valve to the swivel elbow joints and enters the tires. When air is to be removed, the deflation solenoid valve is activated and the air flows from the tires through the valve where it is vented to the atmosphere. A muffler is used on the valve outlet to reduce the air pressure before discharge for safety and noise control. Four safety relief valves set at 137 kPa are used in the inflation/deflation circuit to protect the tires against

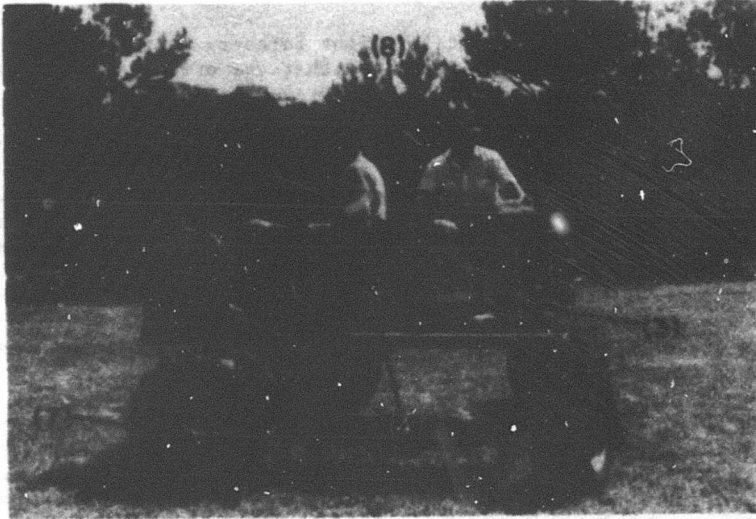

FIG. 4. The ATV equipped with the CTIS and radar speed unit operating on sodded field at NCSU, June 1983, where (1) inflation solenoid valve, (2) deflation solenoid valve, (3) safety relief valves, (4) radar monitor mounted 60 cm above ground at 37° depression angle with the horizontal plane, (5) radar console for direct readout, (6) manual pressure switch circuit, (7) elbow pivot joint connecting the CTIS to the drive wheel, (8) portable air compressor with 3-kW engine.

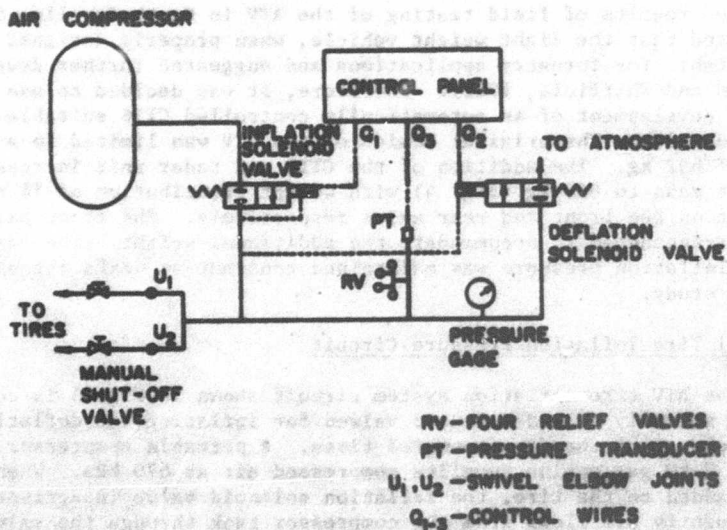

FIG. 5. ATV central tire inflation/deflation system equipped with pressure transducer for controlling tire inflation.

high pressures. The normally open manual shut-off valves are used to prevent air leakage from the tires when the vehicle is not in use for an extended period.

A manual switch circuit composed of two push button battery-operated switches controlling the inflation and deflation solenoids was necessary to investigate the operational characteristics of the tire pressure system and to the development of the control system.

Central Tire Inflation System Tests

Tests of three to five replications were conducted to determine the characteristics of the CTIS under different conditions. The compressor tank fillup rates were 13.8, 11.8, and 10.3 kPa/s with air pressure rising from 0-207, 0-414 and 0-620 kPa respectively. A total of 60 seconds was needed to fill the tank to 620 kPa and five seconds to discharge it completely to the atmosphere.

The average inflation and deflation rates of the ATV tires at different tank pressure settings for three trials are shown in Table 1. The tests were conducted stationary due to difficulties of recording the data while in motion, and the data were consistent and almost identical for all trials. When the compressor tank was pressurized to 207 kPa, the air solenoid valves were inoperable because their pilot pressure has to be greater than 207 kPa to activate the solenoids. The rate of inflation of the ATV tires decreased in general with a decrease in the air compressor pressure and for higher tire pressure settings (Table 1).

The results of the tire and tank pressure tests indicate that the CTIS was adequately designed for the ATV and will provide fast pressure response to tolerate difficult terrains and wet conditions.

INSTRUMENTATION FOR AUTOMATIC CONTROL OF THE CTIS

As in any automatic control system, the pertinent objective is to select sensing and control devices to maintain the most suitable level of inflation pressure. Policies for a particular terrain condition will depend on the inputs and sensitivity of the transducers used.

Sensing and Control Devices

Sensing devices can be a function of ground contact pressure, depth/sinkage of wheels, applied external load, dynamic load on tires, ground condition, ground speed/wheel slip or a combination of any of these variables.

A sensor based on tire-ground contact pressure might be ideal for direct feedback needed for vehicle mobility. Strain gauges imbedded into the tire periphery would provide continuous recording of ground contact pressure that may be sensitive to soil/terrain variations. However, because of the terrain roughness and the severe punishment of the tires under field conditions, the strain gauges would not be able to function properly, which will eliminate this approach.

TABLE 1. CHARACTERISTICS OF THE ATV CENTRAL TIRE INFLATION SYSTEM. SEPTEMBER 1982 - NCSU.

Tire Pressure kPa	Compressor Tank Pressure		Required Time Sec	Average Pressurization Rate kPa/s
	Initial kPa	Final kPa		
A. Tire Inflation Test				
0- 35	620	540	0.5	70
0- 69	620	478	0.9	77
0-103	620	402	1.4	74
0-138	620	206	2.5	55
0- 35	414	341	0.5	70
0- 69	414	207	1.0	69
0-103	414	115	1.5	69
0-138	414	0	17.3	8
0- 35	207	103	1.0	35
0- 69	207	35	3.3	21
0-103	207	0	22.0	5
B. Tire Deflation Test				
103- 0			2.16	48
138- 0			3.16	44
C. Tire Pressurization at Constant Intervals				
0- 35	620	517	0.5	70
35- 69	517	414	0.5	68
69-103	414	310	0.6	57
103-138	310	207	1.5	23

Internal tire pressure would vary with tire deflection and deformation on different surfaces. Therefore, under soft terrain conditions where sinkage takes place, tire deformation will differ, resulting in a change in the tire inflation pressure. A pressure transducer in line with the tire pressure lines (Fig. 5) can predict tire pressure variations within ± 1.0 kPa*. A logic circuit comparing the pressure transducer output with a predetermined window of acceptance composed of

*Personal communication with the National Tillage and Machinery Laboratory staff, USDA, Auburn, Alabama.

maximum and minimum air pressure values, is necessary for the success of this sensing method. Whenever the pressure transducer signal is outside of the window, an appropriate comparator pulse is generated to activate the respective solenoid valve for either deflating or inflating the tires (Fig. 5). The inflation pressure sensing method was discarded because of complexity and time needed for debugging the logic circuit.

A load sensing device can predict the change in resistance due to terrain variation. Unfortunately, under most field conditions the load drags behind the vehicle, therefore, the machine will be immobile before a signal is generated. A change in axle load distribution due to operating on steep terrain might be useful for adjusting the inflation pressure of all tires. Electronic axle load cells are available for heavy truck application and might be utilized in this application.

A sensor based on ground condition measurements such as cone penetration resistance moisture content of soil, depth of snow, or soil density, equipped with a time delay circuit for proper timing will be useful in automatic control of the CTIS. Unfortunately, these soil parameters are not independent of each other and also vary with soil type and structure.

A sensor based on ground speed/slip measurement will provide direct information needed for tire inflation pressure control. The ground speed/slip sensors, normally utilize a microwave Doppler radar unit or a fifth wheel in front of the vehicle for monitoring the slip. Several devices are available and can be readily installed on farm tractors for controlling wheel slip and measuring productivity. It was felt that the speed/slip control technology is well established and can be implemented on the ATV with the CTIS for automatic control of tire inflation pressure.

RADAR GROUND SPEED MEASUREMENTS

Principle of Radar Measurements

The radar sensor provides a true measure of vehicle speed over the ground using the Doppler principle (Fig. 6). Illuminating the ground below the vehicle, the reflected beam is compared with the transmitted beam to derive a difference of Doppler frequency proportional to the vehicle speed.

The Doppler frequency shift is expressed by (Hyltin, et al, 1971):

$$f_d = \frac{2 V_g}{\lambda} \cos \theta$$

where:

- f_d = Apparent Doppler frequency shift in Hertz.
- V_g = Velocity vector (vehicle velocity).
- λ = Wavelength of transmitted beam.
- θ = Angle between the velocity vector and center of the antenna beam (depression angle).

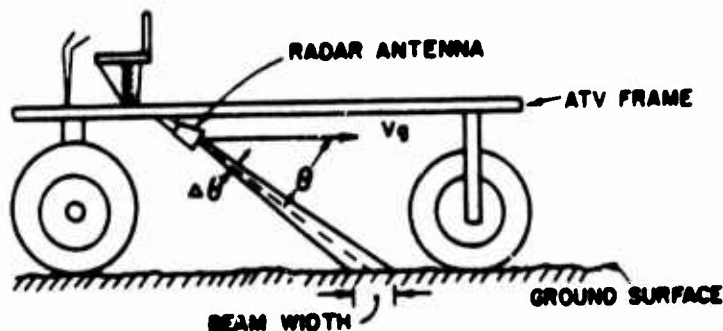

FIG. 6. Geometry of single beam Doppler frequency measurements.

The vehicle velocity is calculated from:

$$v_R = \frac{f_d \lambda}{2 \cos \theta} \quad (1)$$

For an antenna depression angle of 37° and transmitted frequency of 24.125 GHz, a vehicle velocity of 1.609 km/h (1 mph) is equivalent to a Doppler frequency shift of 57.5 Hertz (Tsuha, et al, 1982). The output of the radar sensor is a square wave whose frequency is directly proportional to the vehicle velocity. The frequency to speed conversion factor is approximately 35.7 Hz/km/h (57.5 Hz/mph) when the sensor is mounted at a depression angle of 37° , approximately at 0.6-1.0 m (24-39") above the ground. It will operate satisfactorily while facing in either direction; forward or rearward.

A Radar Sensor for the ATV

A radar unit (Dickey-John TPMII) was installed on the ATV as close as possible to its center of mass, approximately 60 cm above the ground with depression angle of 37° and transmitted frequency of 10.535 GHz resulting in calibration factor of 1 Hz/cm/s (44.7 Hz/mph). The unit monitor console displays ground speed, wheel slip, engine rpm, and area covered. A 10-tooth sprocket based on the radar pulse rate of 223.5 pulses/s for the wheel slip measurement was first evaluated but because the ATV was hydrostatically driven and operated at low speeds, a 96-tooth sprocket and a magnetic pickup transducer mounted on the right wheel axle to determine wheel slip were most suited for this application.

The output signals on the radar console are at the rate of one read-out per second, which is very slow because of the time delay in processing the signals. An interface circuit with the input signals to the TPM II-MD4332B registers will be constructed and fed to an external computer for controlling the tire inflation pressure based on slip and/or ground speed inputs. When developed, this automatically operated ground speed

central tire pressure system will represent a great revolution in vehicle mobility and in optimizing field operations which will result in substantial energy and cost savings.

Radar Performance & Evaluation

The main components of the radar unit are an antenna, a microwave transceiver, an estimator and a microprocessor. The horizontal speed is calculated from the radar transmitted signal (Eqn. 1) and the slip is calculated either from the engine rpm for direct drive vehicles or from wheel rpm for hydrostatically driven vehicles such as the ATV used in this study.

Tests of the radar unit to determine its characteristics were conducted in Fall, 1982 on a paved road and on a sodded football field, NCSU campus, Raleigh. The vehicle was operated at constant full throttle with constant rear tire pressure of 48 kPa and front tire pressure ranging from 13.8 to 110.3 kPa. The trails were approximately 30 meters long on nearly straight and level ground. The data shown in Table 2 are the average of all recorded points along the trails for each tire inflation pressure. The ground speed on the paved surface was fairly constant at all tire pressures, however, it increased slightly with an increase in tire inflation pressure on the sod. The slip percent readings were erratic and constantly changing. After repeating the tests at tire pressures of 27.6 and 110.3 kPa, it was concluded that the slip measurements were not sufficiently accurate for controlling tire inflation pressure. Contrarily, the ground speed readings were within ± 0.15 km/h for the same test run (Table 2).

Calibration of the radar ground speed measurements was conducted on two 152.4-m trails, one on paved road and the other on sod, on the NCSU Campus by recording the time for each 30.5 meters (station) along the trail and at least four radar console readings for each station. The results of this calibration indicated that the radar recorded ground speed measurements (V_r) were less than the average recorded speed using a stop watch (V_t); the error is within + 3.5 percent. The statistical equation of all data points obtained from this calibration test was:

$$V_t = 1.036 V_r \quad (2)$$

Traction/Slip Test Results

Relationships between slip and ground speed under different loading conditions have been established by several investigators in the agriculture and off-road vehicle fields. A pull test was conducted on a heavy sandy clay soil at the Schenck Memorial Forest, 8 km west of NCSU campus. A 152.4-m trail was established with five stations marked every 30.5 m. The average moisture content of the soil was 52.4 percent on dry weight basis. A skid pan loaded with pulpwood was used to load the ATV during the traction test. The test was conducted at four tire inflation pressures (Table 3). The radar speed and slip data were read directly from the console and recorded on a microcassette recorder by one operator riding on the ATV and the time travelled per station for

TABLE 2. PERFORMANCE OF THE RADAR UNIT AT DIFFERENT INFLATION PRESSURES AND NO LOAD. NOVEMBER 1982.

Tire Pressure kPa	Rolling Radius mm	Engine RPM		Ground Speed km/h		Slip %	
		mean	σ^*	mean	σ	mean	σ
A. Paved Surface							
13.8	316	3256	6	8.0	0.08	3.6	0.6
27.6	337	3211	13	8.0	0.14	3.2	0.8
41.4	348	3218	10	8.1	0.08	3.2	0.8
55.2	352	3223	7	8.2	0.13	1.6	0.6
68.9	357	3232	13	8.5	0.08	2.4	0.6
82.7	360	3226	6	8.5	0.14	2.4	0.6
96.5	364	3234	6	8.5	0.06	3.0	0
110.3	365	3231	4	8.5	0.06	2.8	0.5
B. Sod Surface							
13.8	316	3175	4	7.6	0.14	5.8	0.4
27.6	337	3199	7	7.7	0.13	4.4	0.9
41.4	348	3218	15	7.9	0.18	3.8	1.1
55.2	352	3209	6	8.1	0.18	4.6	1.3
68.9	357	3223	9	8.2	0.11	3.4	1.1
82.7	360	3220	4	8.3	0.08	2.0	0.7
96.5	364	3253	4	8.5	0.13	2.0	0
110.3	365	3248	3	8.4	0.08	2.4	0.6

*Standard Deviation

speed and travel reduction measurements was recorded by another operator on the ground.

The results of these tests indicated again the reliability of the ground speed measurements and unacceptability of the slip readings obtained by the Dickey-John unit. The radar data output prior to processing was monitored on an oscilloscope and found consistent. Calibration of the radar unit to relate pulse counts to ground speeds will be conducted in the laboratory using a variable speed belt unit. A logic circuit is under investigation to control the tire inflation pressure.

TABLE 3. RESULTS OF THE PULL TEST AT THE SCHENCK MEMORIAL FOREST, NCSU WITH THE ATV OPERATING AT FOUR TIRE PRESSURES. NOVEMBER 1982.

Tire Pressure kPa	Pull N	Travel Reduction %	Ground Speed km/h	Radar Measurements	
				Speed km/h	Slip %
27.6	0	0	7.7	7.4	4.7
	111	2.7	7.5	7.1	5.9
	313	6.9	7.1	6.9	5.8
	644	14.5	6.6	6.4	9.2
55.2	0	0	7.9	7.6	3.2
	111	4.2	7.5	7.1	4.6
	327	5.4	7.5	7.2	4.5
	859	16.2	6.6	6.5	10.4
82.7	0	0	8.1	7.8	3.1
	111	3.9	7.8	7.3	3.7
	367	5.3	7.7	7.4	3.7
	862	17.7	6.7	6.6	11.8
110.3	0	0	8.1	7.8	2.9
	111	4.1	7.8	7.2	3.2
	433	5.4	7.6	7.4	4.4
	865	17.3	6.7	6.8	12.9
	1376	21.2	6.4	6.2	12.1

CONCLUSIONS AND RECOMMENDATIONS

1. The radar speed measurements are suitable and accurate for detecting ground speed of forestry and off-road vehicles.
2. The central tire inflation system design was adequate and can be extended to larger vehicles and skidders.
3. Work is in progress to interface with the radar console speed and wheel rpm signals to automatically control the tire inflation pressure.

REFERENCES

1. Burt, E. C. and A. C. Bailey. 1982. Load and inflation pressure effects on tires. Transactions of the ASAE 25(4):881-884.
2. Czako, T. F. 1974. The influence of the inflation pressure on cross-country performance. Journal of Terramechanics 11(3 & 4):13-23
3. Grevis-James, I. W. and P. D. Bloome. 1982. A tractor power monitor. Transactions of the ASAE 25(3):595-597.
4. Hassan, A. E. and J. K. Whitfield. 1982. Student design of an all-terrain vehicle for forestry operations. SAE Technical Paper Series #821041, 7 P.
5. Hassan, A. E. 1978. Effect of mechanization on soils and forest regeneration. I. Coastal Plain organic soil. Transactions of the ASAE 21(6):1107-1111.
6. Hyltin, T. M., T. D. Fuchser, H. B. Tyson, W. R. Regueiro. 1973. Vehicular radar speedometer SAE Paper Series #730125, 36 P.
7. Kaczmarek, R. W. 1981. Innovative mobility designs utilized on foreign wheeled and tracked vehicles. Proceedings of the 7th International Conference, ISTVS, Calgary, Alberta, Vol. 1: 263-296.
8. Richardson, W. A., R. L. Lanning, K. A. Kopp and G. J. Carnegie. 1982. True ground speed measurement techniques. SAE Technical Paper Series #831058. 10 P.
9. Tsuha, W., A. M. McConnell and P. A. Witt. 1982. Radar true ground speed sensor for agricultural and off-road equipment. SAE Technical Paper Series #821059. 9 P.
10. Zombori, J. 1967. Drawbar pull tests of various traction devices on sandy soils. Journal of Terramechanics 4 (1):9-17.

