

SAFETY OF HIGH EXPLOSIVES COMMINUTION PROCESSES

R Applin

AWRE ALDERMASTON

AD P 000 464

1. INTRODUCTION

Many properties of explosives are influenced by the particle size of the explosive, eg.

- (a) Consolidation characteristics of pressable, castable and extrudable HE systems.
- (b) Rheological and mechanical properties.
- (c) Hazard potential of both powders and consolidated compacts.
- (d) Initiation and propagation properties.

UK military explosives are supplied from the Royal Ordnance Factories in a restricted number of grades, therefore, AWRE is involved in comminution of secondary high explosives in order to

- (a) to do necessary research on the effects of particle size on various properties, and
- (b) based on that research, to tailor explosives to meet particular requirements.

↓
The explosives which are of interest include HMX, RDX, TATB, NQ, TNT, PETN and HNS and mixtures of these materials. These explosives are subjected to a variety of milling processes on the experimental and pilot plant scale. The quantities involved range from 1 or 2 kg to several hundred Kg.

↙ Various methods of comminution are in use;

- (a) end-runner milling (a mechanical pestle and mortar)
 - (b) ball-milling
 - (c) colloid or paste milling
 - (d) slurry or attrition milling
-

- (e) fluid-energy milling, *link*
- (f) precipitation from solvent combined with fluid-energy milling.

This paper will outline the methods of comminution used at AWRE and then deal in more detail with how a number of safety problems have been dealt with.

2. COMMUNITION METHODS

2.1 All comminution operations on explosives at AWRE are carried out under remote control. Precipitation methods where no milling is involved are carried out under close control.

2.2 End-Runner Milling

This is essentially a mechanical pestle and mortar, (See Figure 1). The mortar is turned by an air-driven motor; the pestle revolves by the effects of friction and the material to be milled is crushed between the bottom of the mortar and the surfaces of the pestle.

Compositions such as TNT flake or Comp B are milled dry; other materials are milled under water. PETN is not milled by this method.

Many of the compositions prepared at AWRE contain rubbery binders and are in the form of coarse agglomerates which are not suitable for testing by our standard powder safety tests. Crushing at room temperature often is not effective in reducing the size of the agglomerates. However, milling in liquid nitrogen in the end-runner mill, where the temperature has been reduced to well below the glass transition temperature of the binder, is effective. The liquid nitrogen also acts as a diluent and ignition quencher in the same manner as water.

One disadvantage of the method is that atmospheric moisture is condensed onto the milled sample which necessitates a further drying stage and also means that it cannot be used for moisture sensitive compositions.

2.3 Ball Milling

This method is now only used on a small scale for experimental purposes. There are two reasons for this:

- (a) the relatively large quantities of explosive being processed at one time if the process is being used to produce worthwhile quantities of powder;
- (b) contamination of the product by material from the balls.

2.4 Colloid (paste) Milling

This is a method developed at AWRE in the late 1950's and it is used to produce our standard fine HMX (HMX Type B). Figure 2 shows the particle size distributions of three grades of HMX in use at AWRE.

The mill consists of a conical rotor, driven at high speed, turning inside a matching stator with a gap of a few thousandths of an inch; both the rotor and stator are made in carborundum. Figure 3 is a drawing of the stones. Stainless steel rotors and stators have been tried but the stability of rotation is not good enough to prevent the milling surfaces touching and binding.

The mill is fed with slurry from a circulation circuit which is designed to keep the slurry in suspension by the velocity of the circulating flow. The circuit is shown diagrammatically in Figure 4 and in place of Figure 5.

The product of this type of milling is a bimodal powder with good packing properties. However, a minute number of carborundum particles contaminate the product and, although they do not present a safety hazard and there is no problem in meeting the stringent grit clause of the specification, the grit particles occasionally manifest themselves in embarrassing situations. Because of this AWRE is moving away from colloid milled material to that produced by fluid-energy milling where there are no moving parts or carborundum stones.

2.5 Slurry Milling (Attrition Milling)

The kinetic energy of the circulating slurry in the circulation system for the colloid mill has been put to use in a form of milling known as slurry milling. The flow from two centrifugal pumps is directed to the opposing arms of a Tee-piece of reduced diameter. The impact of the colliding explosive crystals is of sufficient violence to cause their attrition. This method, run on a continuous recirculation system, produces a powder with a particle size distribution, for HMX, intermediate between Type A and Type B. An important attribute of the material produced in this way is the rounded nature of the crystals.

2.6 Fluid-Energy Milling (Micronizing)

The second major method of milling, and the currently preferred method, in use at AWRE is fluid-energy milling. The milling takes place by collision of particles of material, one with another, in the very vigorous turbulence created inside the mill by colliding high pressure air jets. The centrifugal motion of the air flow partially classifies the powder so that the coarser material is retained in the milling area, thus allowing further comminution to take place. Figure 6 is a sketch of the mill; Figure 7 shows the two 300 mm mills installed at AWRE.

The milling is carried out with an aqueous slurry of the explosive and a considerable proportion of the energy input is used in moving water around. For use with TATB, a small fluid-energy mill has been installed which is being fitted up for use with dry powder. This is shown in Figure 3.

The product of this type of milling is unimodal.

2.7 Precipitation

Precipitation of explosives from solution in a variety of solvents by feeding the solution into stirred water is a recognised procedure for producing materials with closely tailored characteristics.

At AWRE this form of precipitation has been combined with fluid-energy milling to produce very fine and very pure powders.

PETN with a surface area of about $3 \text{ m}^2/\text{g}$ has been produced by this method.

3. SAFETY CONSIDERATIONS

3.1 Sources of Hazard in Comminution

There are several sources of hazard in our methods of comminution ie.

- (a) impact
- (b) friction
- (c) viscous heating
- (d) electrostatic discharge (dry powders and fuel/air mixture ignition).

The response to these stimuli are influenced by -

- (a) the particle size of the explosive
- (b) the concentration of the slurry, dust cloud, or solvent
- (c) the nature of the explosive.

The over-riding objective when any explosive process is introduced is to eliminate, if possible, the sources of hazard, but, if this cannot be achieved to reduce the hazard to the minimum. This has been done with the comminution processes used at AWRE and the following paragraphs discuss individual areas of operation.

3.2 Slurry Pumping

There are two slurry pumping circuits installed in our milling building:

- (a) A 25 mm diameter circuit pumped by an orbital lobe pump for use when preparing 1 - 10 kg quantities of product using the fluid-energy mill. The circuit is shown diagrammatically in Figure 9.
- (b) A 50 mm diameter circuit pumped by one or two (depending on the process) centrifugal pumps delivering 35 - 40 imperial gallons per minute against zero head. This circuit is used when preparing large quantities of product using the fluid-energy mill, colloid mill or by slurry milling. The circuit is shown diagrammatically in Figure 10.

The orbital lobe pump was chosen for the 25 mm circuit because of its inherently safe design. The body of the pump is rubber and the lobe is rubber coated. This design avoids any metal to H₂O friction in the pump.

The centrifugal pumps on the larger circuit have been modified with an AWRE designed gland lubrication system that prevents ingress of slurry into the gland from the pump. Figure 11 is a diagram of the system.

The gland was modified by having a PTFE bush with a helical groove fitted and the pump body was tapped in two places to communicate with this bush. An additional tapping into the pump body communicates directly with the pumping chamber. A filtered water flow is supplied through a flow controller to the bush. The downstream side of the water flow is connected to a pressure relief valve; the pump chamber is connected to the same valve. The water flowing around the gland is drained through the pressure relief valve whilst the pressure of the water flow is greater than the pressure being generated in the pump chamber. If the pressure in the pump chamber exceeds that in the bush the pressure release valve closes and the water flow in the gland flushes into the pump body, so preventing ingress of solids into the gland.

Although the centrifugal pumps have a good safety record at AWRE, it is recognised that there is a slight risk involved in their use. It has therefore been decided to replace them with an inherently safer design of pump, probably of the diaphragm type.

3.3 Slurry Circuits

When the major pieces of milling equipment were installed in the late 1950's experiments were carried out to find the concentration threshold of the propagation of detonation for slurries of HMX in water confined in 50 mm diameter stainless steel tube. It was found that, for

both suspended slurries and settled slurries in horizontal tube, detonation would not propagate at 30 per cent solids concentration when boosted by a 25 mm diameter, x 25 mm long cylinder of Comp B.

Guided by these results, the upper concentration limit for slurries of HMX and RDX permitted in the AWRE plant is 25 per cent. PETN has only been milled at low concentration (< 10 per cent).

More recent studies by Petrino et al (1) using gelled slurries have shown that detonations can be obtained in 30 per cent HMX slurries, but have confirmed that detonation will not propagate in 25 per cent HMX slurry. However, they obtained detonations in settled 5 per cent HMX slurry. They recommend that HMX slurries should not be allowed to sediment.

The approval that was given to work at 25 per cent HMX slurry concentration at AWRE, was conditional on

- (a) the pipe work being clear plastic to enable points of sedimentation to be identified and cleared;
- (b) each pipe run having a vertical section in the plant room to provide a break in any sedimented train of explosive and so prevent propagation of any ignition to the slurry preparation room.

Before and after each run using the fluid-energy mill or the colloid mill the slurry systems are flushed well with water to minimise sedimentation.

3.4 Colloid Mill

The major source of hazard with this type of mill is feeding dry material to the mill on start up, eg. between periods of use, slurry sedimenting and drying out; or failure during a milling run of the slurry pump leading to the loss of liquid feed to the mill.

These situations are guarded against by having the mill fitted with an independent, gravity fed, supply of water that is used to flush the mill before and after use; it is also capable of being switched in and out during a milling run.

3.5 Electrostatic Hazards

All fixed equipment and all other equipment above approximately 1 cubic foot volume is bonded to the earth bond of the building. This will prevent the build up of electrostatic charge of sufficient energy to ignite dusts of the explosives in use at AWRE.

When flammable solvents are in use a high level of ventilation is maintained to prevent the build up of solvent/air mixtures of ignitable proportions.

3.6 Viscous Heating

This is more of a nuisance than a hazard. When slurry milling or producing fine powders by the continuous recirculation of product to either the colloid mill or the fluid energy mill, the energy deposited in the slurry from the pumps appears as heat and consequently the slurry warms up. To remove this heat, which would soften the plastic pipes of the circulation system, the slurry is passed through a water cooled heat exchanger.

4. CONCLUSIONS

The explosives comminution operations at AWRE are run in as safe a manner as can be devised. The equipment and methods of operation are regularly reviewed to determine whether improvements can be made. However, the probability of an explosive event, although low, is greater than would allow the equipment to be run under close control.

This paper has presented the reasons for that conclusion and the steps that have been taken to minimise the likelihood of an explosive event.

REFERENCE

1. Petino G, Westover D, Scola R :
Detonation Propagation Tests on Aqueous Slurries of RDX
and HMX
Hazards Research Corp. Denville N.J.
ARLDC-CR-77002 April 1977.

COPYRIGHT © CONTROLLER HMSO 1982



Figure 1 End-runner mill

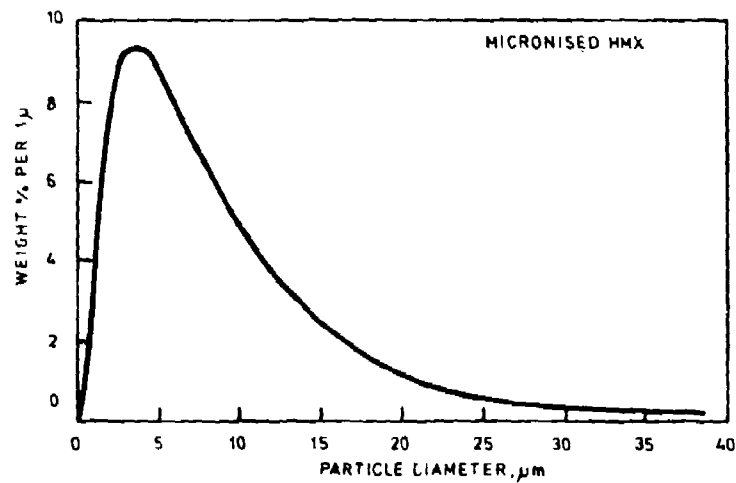
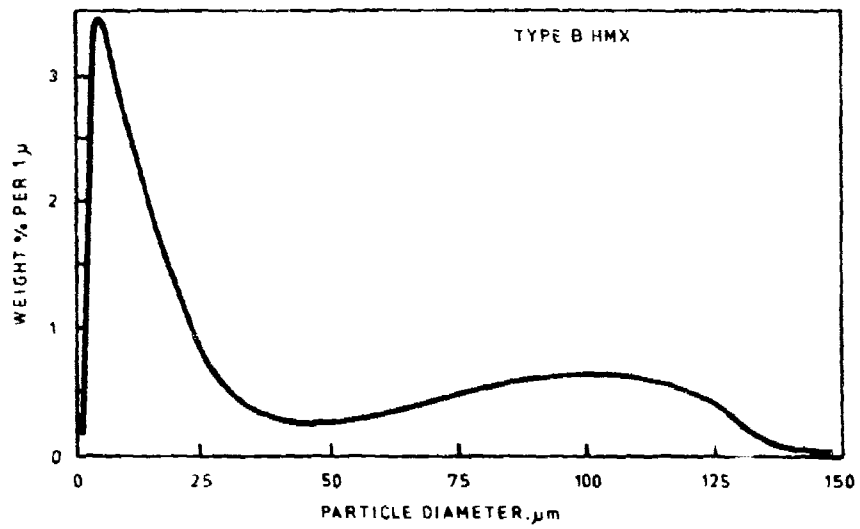
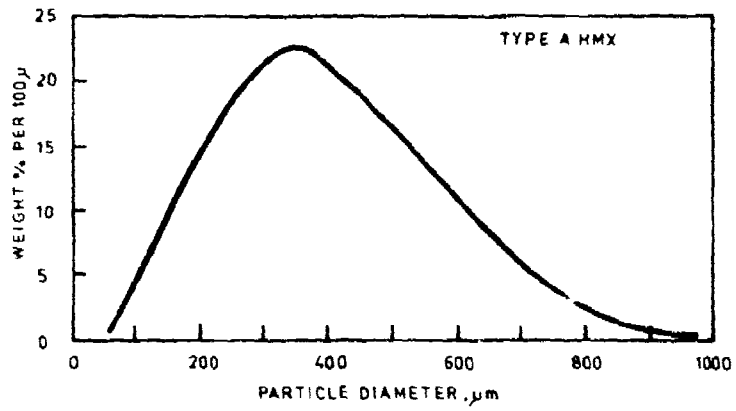

FIGURE 2 Particle Size Distribution of HMX Types Used at AWRE

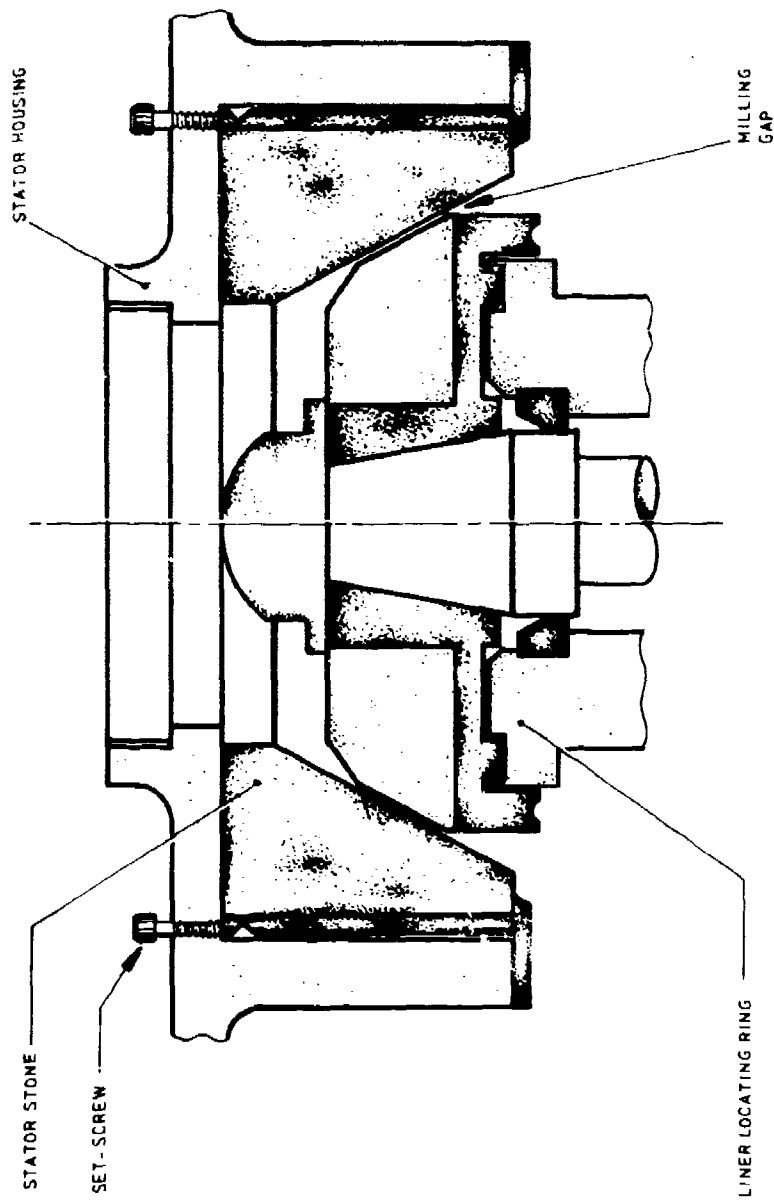

FIGURE 3 Carborundum Milling Units

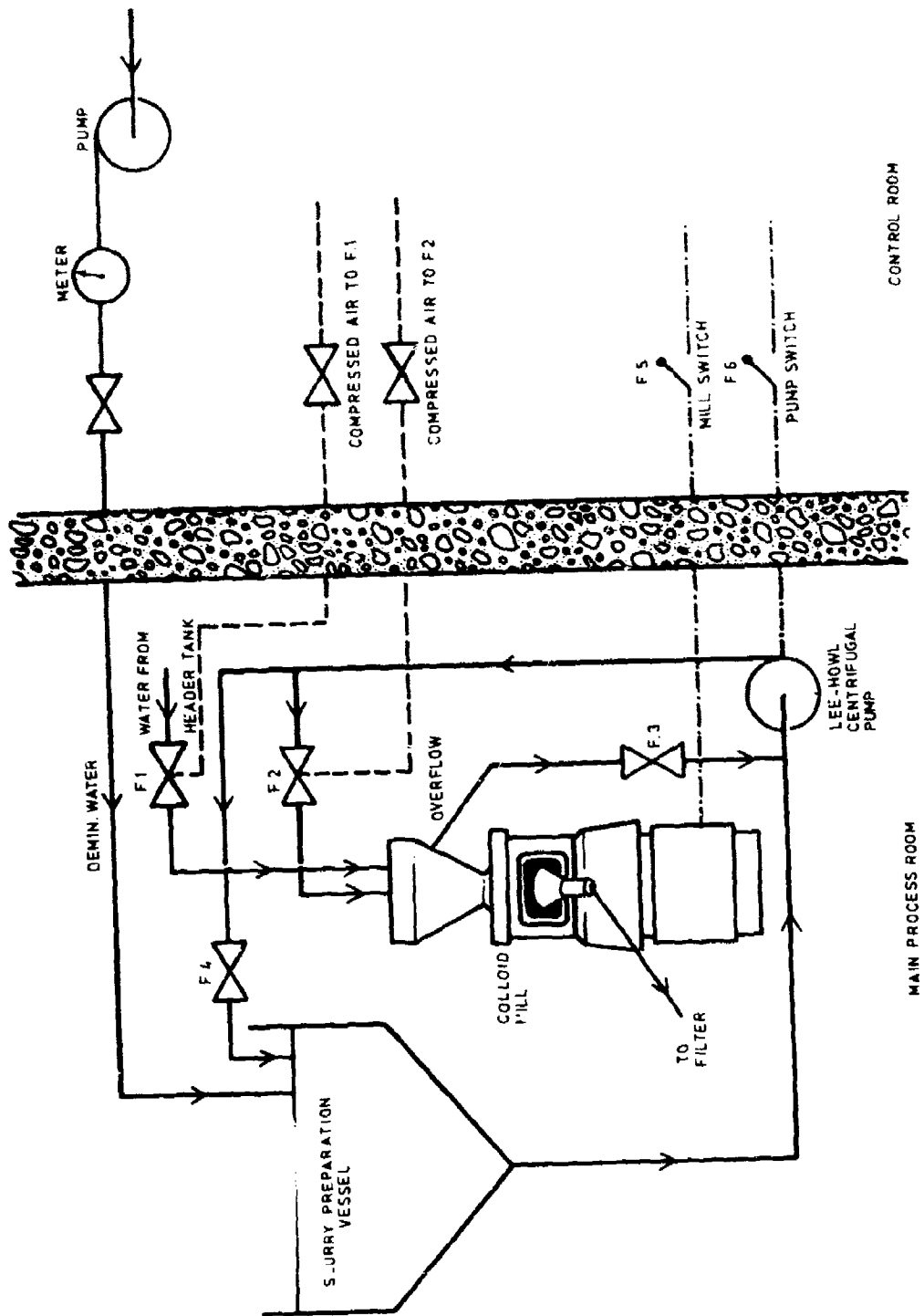

FIGURE 4 Colloid - Milling Circuit

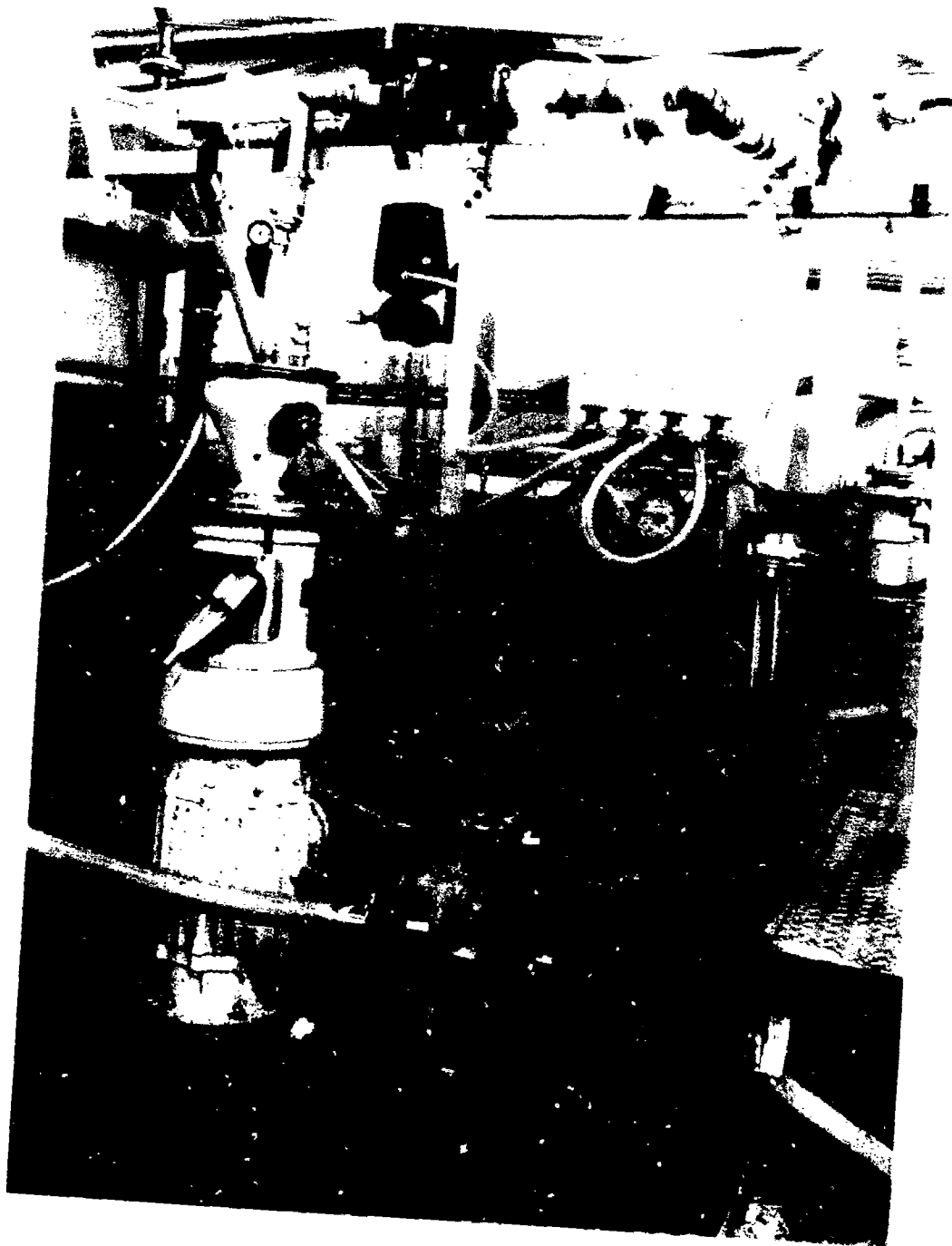

Figure 5 Colloid mill

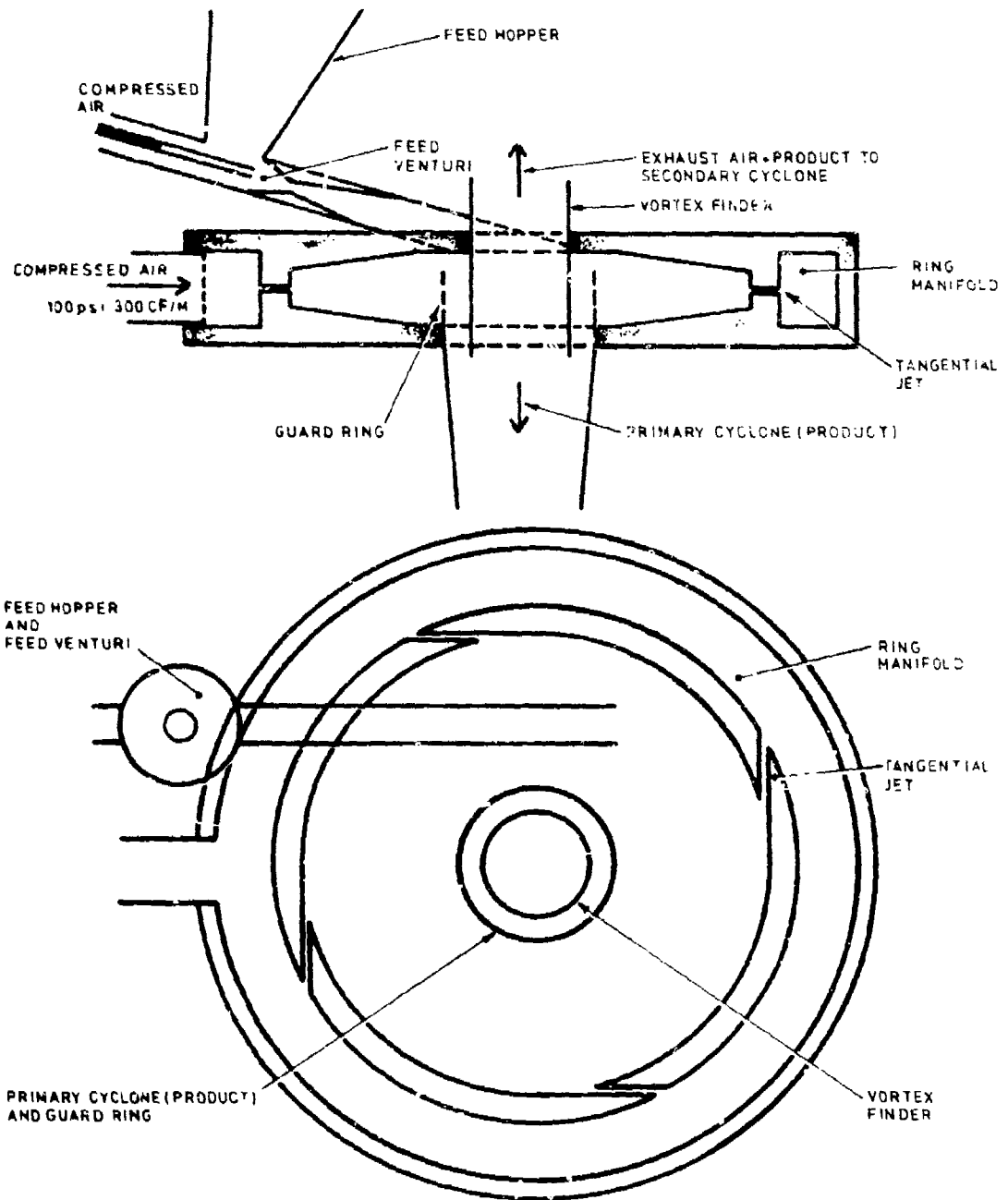

FIGURE 6 Fluid-Energy Mill (Micronizer)

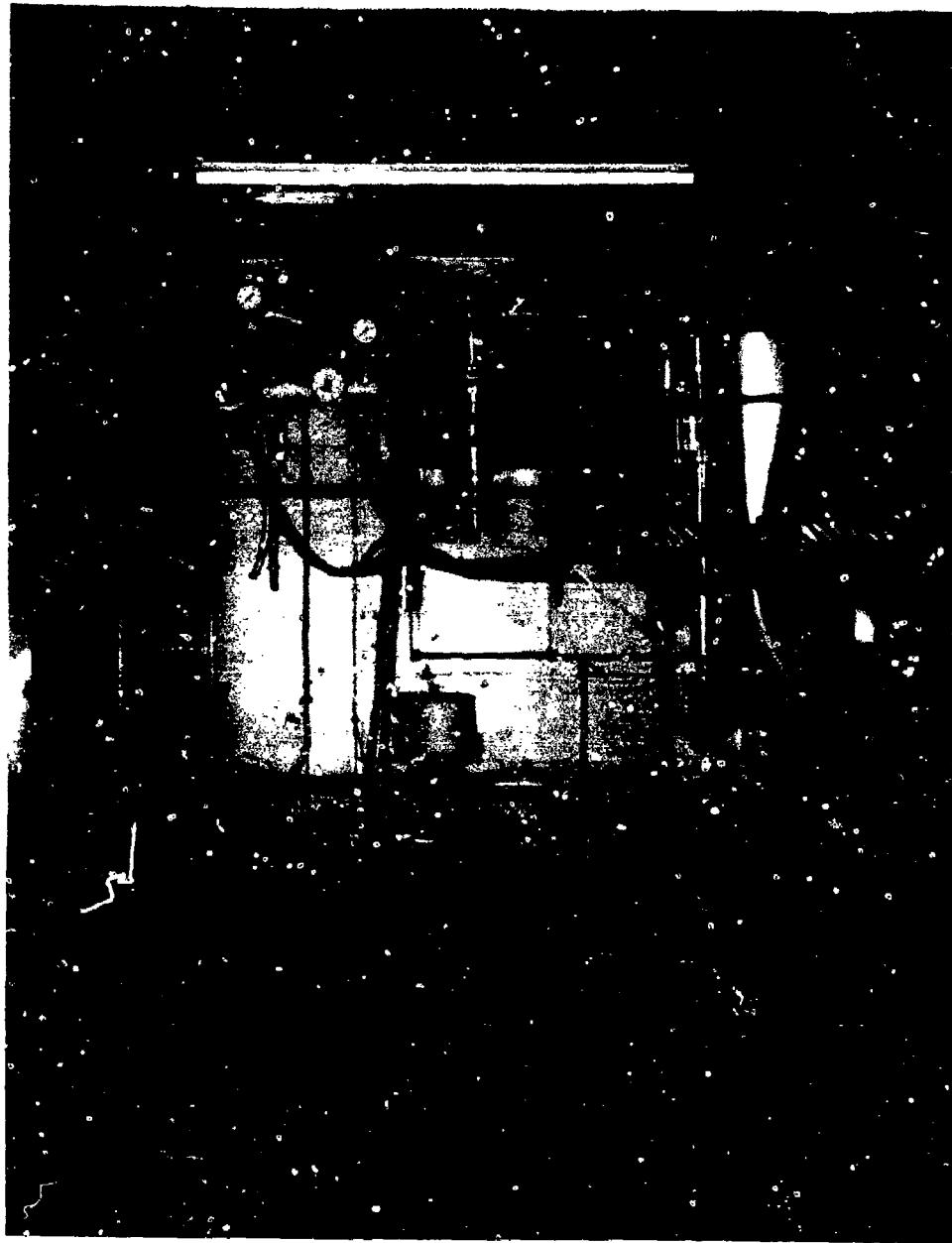

Figure 7 Fluid-energy mills



Figure 8. Small four-energy mill.

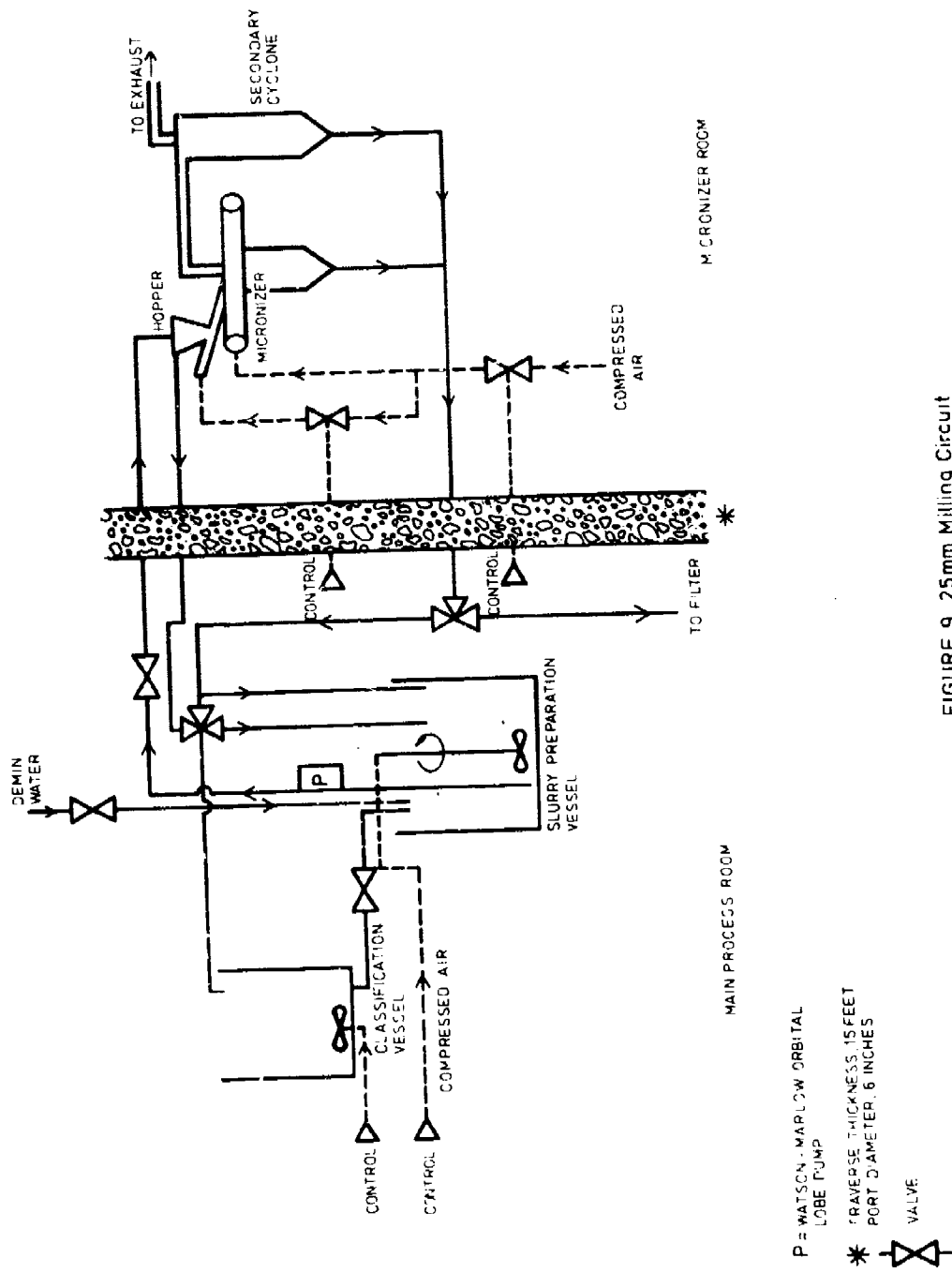

FIGURE 9 25mm Milling Circuit

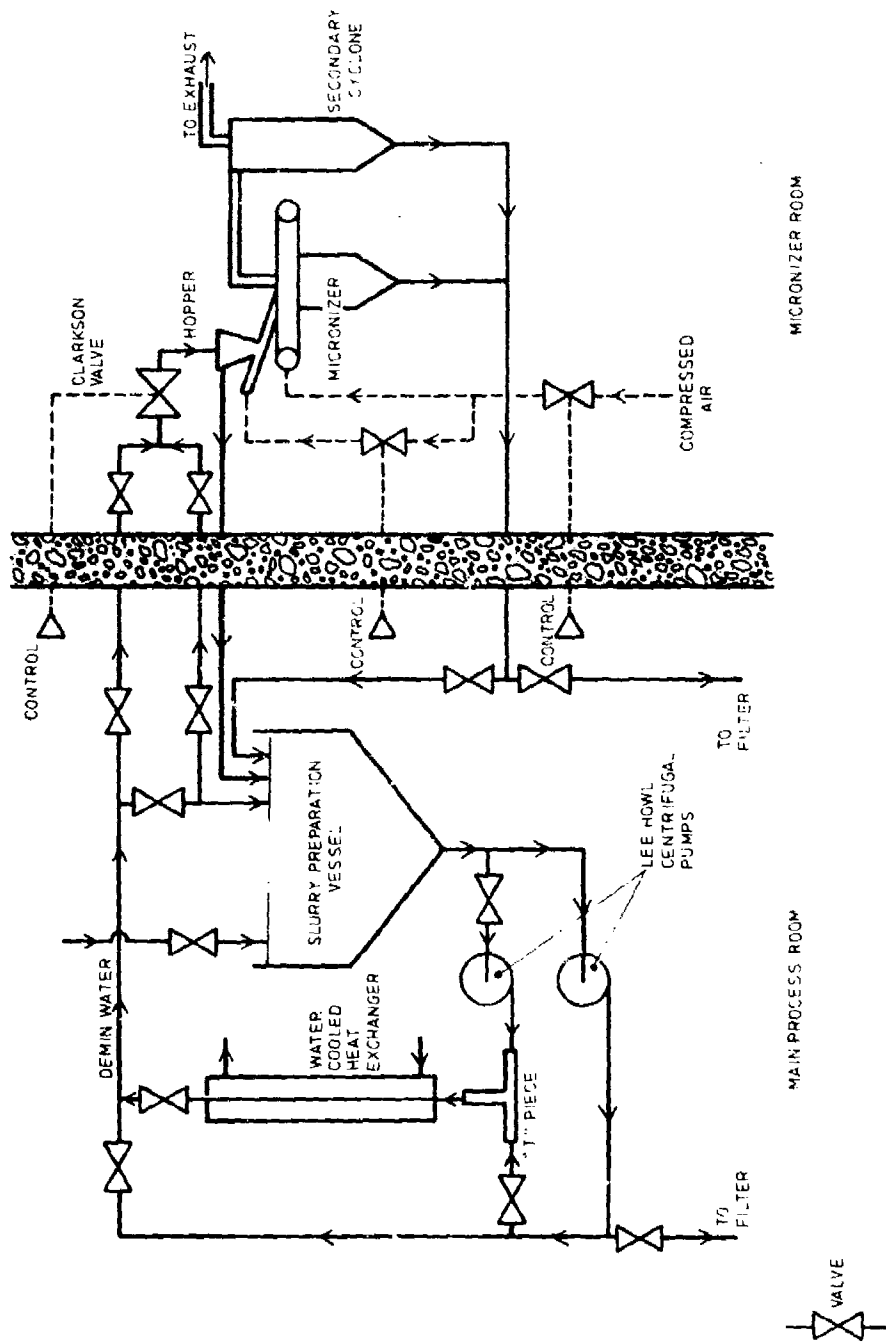

FIGURE 10 50mm Slurry-Milling / Micronizing Circuit

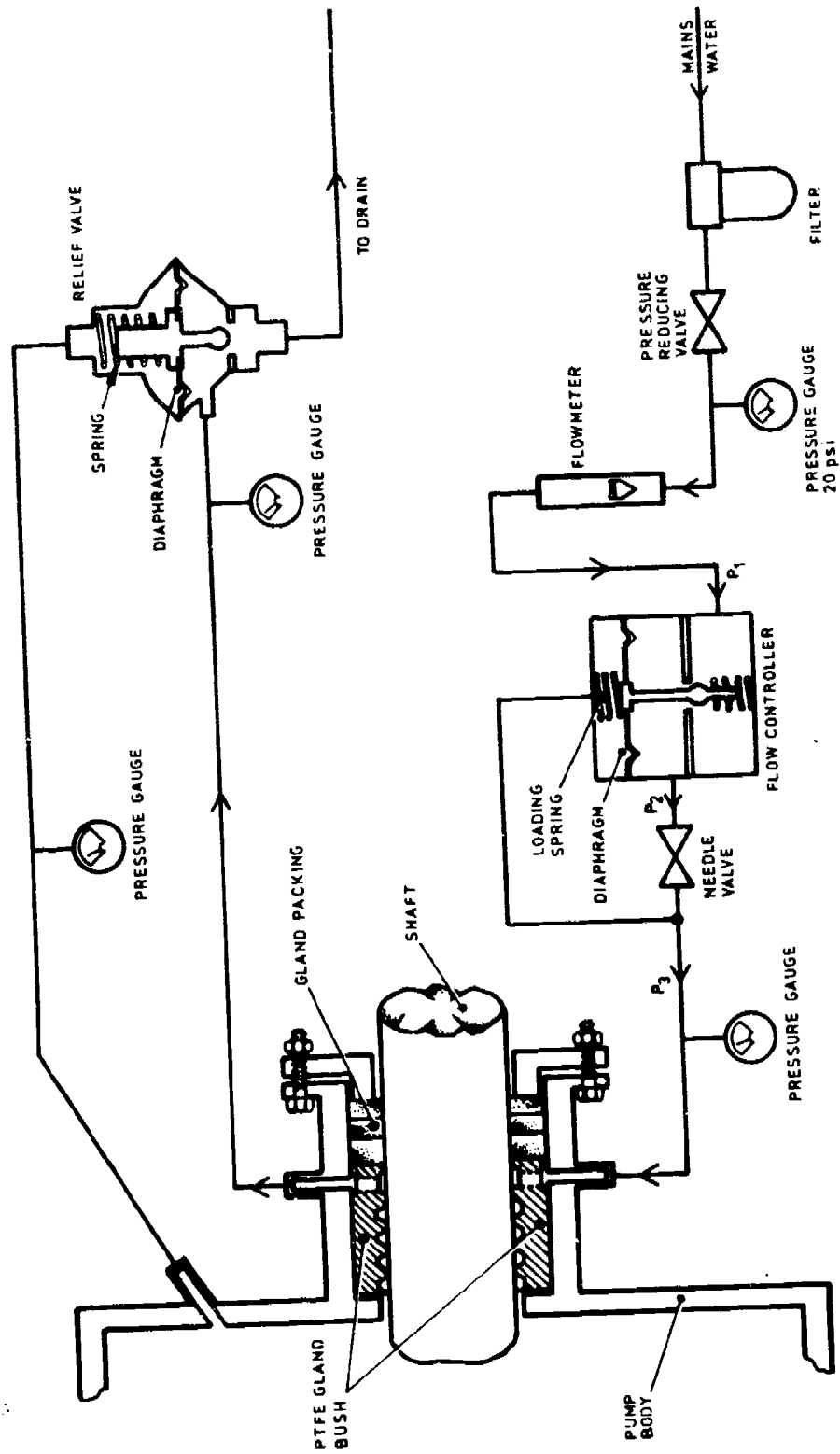

FIGURE 11 Pump Gland Lubrication System