



DEPARTMENT OF THE NAVY
NAVAL UNDERSEA WARFARE CENTER
DIVISION NEWPORT
OFFICE OF COUNSEL
PHONE: 401 832-3653
FAX: 401 832-4432
DSN: 432-3653



Attorney Docket No. 100309
Date: 28 Mar 2011

The below identified patent application is available for licensing. Requests for information should be addressed to:

TECHNOLOGY PARTNERSHIP ENTERPRISE OFFICE
NAVAL UNDERSEA WARFARE CENTER
1176 HOWELL ST.
CODE 07TP, BLDG. 990
NEWPORT, RI 02841

Serial Number 13/004,152
Filing Date 11 Jan 2011
Inventor Paul J. Carreiro

Address any questions concerning this matter to the Office of Technology Transfer at (401) 832-1511.

20110331243

DISTRIBUTION STATEMENT
Approved for Public Release
Distribution is unlimited

MICRO-UNMANNED AERIAL VEHICLE DEPLOYMENT SYSTEM

STATEMENT OF GOVERNMENT INTEREST

[0001] The invention described herein may be manufactured and used by or for the Government of the United States of America for governmental purposes without the payment of any royalties thereon or therefor.

CROSS REFERENCE TO OTHER PATENT APPLICATIONS

[0002] None.

BACKGROUND OF THE INVENTION

(1) Field of the Invention

[0003] The present invention relates to a device for deployment from a cruise missile and more particularly for submunition that is capable of deploying small unmanned aerial vehicles.

(2) Description of the Prior Art

[0004] Tomahawk cruise missile variant UGM 109D is designed to deliver four payload modules of six small submunitions each to multiple targets. Submunitions are positioned in a submunition compartment with a close sliding fit and are retained in the compartment by a submunition latch. The submunition is deployed by a charge positioned in the

submunition compartment which moves the submunition into the slipstream around the missile. Once the submunition enters the slipstream around the missile, aerodynamic forces pull it away from the missile. A submunition is typically an explosive weapon, however, other uses have been contemplated for this capability.

[0005] United States Patent No. 6,498,767 to Carreiro was issued for a "Cruise Missile Deployed Sonar Buoy". This patent teaches a sonar buoy adapted to be deployed by a cruise missile from its submunition compartment. The sonar buoy includes a flotation device for keeping a portion of the buoy afloat, a hydrophone, a transmitter for communicating contact and position information and releasable means for attaching the sonar buoy to the cruise missile. By means of this device, a means of monitoring littoral and other waters for enemy submarines and other threats is provided with a low degree of risk to friendly forces. A system for deploying this sonar buoy in a sonar buoy field is also disclosed.

[0006] Also relevant is United States Patent No. 6,484,641 for a "Cruise Missile Downed Airman Decoy". This patent teaches that a cruise missile, such as the Tomahawk cruise missile, can be adapted to deploy decoys in an area as the missile progresses along its preprogrammed course. Each decoy is shaped to be compatible with and ejected from the Tomahawk missile

submunition compartment and has a preprogrammed control unit operating a transmitter connected to an extendible antenna. False beacon signals and/or false message signals are transmitted from each of the decoys to deceive and confuse defensive forces, such as enemy searchers looking for a downed airman.

[0007] Unmanned aerial vehicles have been a recent addition to ground combat. Of relevance to the current invention are micro-unmanned aerial vehicles (MUAVs). Known MUAVs are less than six inches in length, with a maximum range of approximately seven miles and flight endurance of up to one hour. The MUAV can deploy useful micro payloads to a remote or otherwise hazardous location where it may perform any of a variety of missions, including reconnaissance and tagging high-value targets, bio-chemical detection and classification, battle damage imaging and assessment and search and rescue. For these purposes, the MUAV can be equipped with an appropriate sensor joined to a transmitter.

[0008] The MUAV is controlled externally by directional antennas from ground, surface ship, submarine, or airborne platforms. The MUAVs, acting alone or in small, cooperative groups, can provide reconnaissance and surveillance of inner city areas, serve as communication relays and place sensors on elevated surfaces.

[0009] Although the MUAV serves well in its intended purpose, one serious limitation of the MUAV is its limited range and endurance. Consequently, MUAVs must be deployed relatively close to their selected area of operation. It is desired that means be provided to extend the range of operation of the weapon system, such as the weapon system deploying MUAVs.

SUMMARY OF THE INVENTION

[0010] Accordingly, it is an object of the present invention to provide means for extending the range of operation of a weapon system deploying MUAVs.

[0011] Another object of the present invention is to provide means for adapting a system for dispensing submunitions to dispensing submunitions such as MUAVs having a limited range.

[0012] In accordance with the present invention, there is provided a micro-unmanned aerial vehicle deployment system for a cruise missile having submunition compartments. The system includes a vehicle launch module releasable from the cruise missile submunition compartment. The vehicle launch system has a control circuit and at least one micro-unmanned aerial vehicle contained therein. Structure is provided in the launch module for deploying the micro-unmanned aerial vehicle. The system can include a separable tether joined between the cruise missile and

the vehicle launch module that separates when subjected to tension after deployment of the vehicle launch module.

BRIEF DESCRIPTION OF THE DRAWINGS

[0013] Other objects, features and advantages of the present invention will become apparent upon reference to the following description of the preferred embodiments and to the drawings, wherein corresponding reference characters indicate corresponding parts throughout the several views of the drawings and wherein:

[0014] FIG. 1 illustrates some of the features of a cruise missile (specifically the Tomahawk UGM-109D variant or the like);

[0015] FIG. 2 generally illustrates features of the payload module of the cruise missile;

[0016] FIG. 3 generally illustrates a Micro Unmanned Aerial Vehicle (MUAV) module;

[0017] FIG. 4 schematically illustrates the MUAV module of the present invention prior to the deployment thereof;

[0018] FIG. 5 schematically illustrates a flight path of a cruise missile dispensing multiple MUAVs there along;

[0019] FIG. 6 illustrates details associated with the MUAV module ejection;

[0020] FIG. 7 illustrates the MUAV module status following ejection thereof from the missile; and

[0021] FIG. 8 illustrates the MUAV module status after an associated parachute has been deployed.

DETAILED DESCRIPTION OF THE INVENTION

[0022] As discussed previously, deploying multiple Micro-Unmanned Aerial Vehicle (MUAV) has many benefits, but there are limitations concerning its range of operation. The present invention eliminates the range limitation by adapting a system for dispensing multiple short range vehicles, into a known submunition deployment system. The known submunition deployment system utilizes a cruise missile, such as a Tomahawk variant UGM 109D. This type of missile can be launched from submarine, surface or airborne locations. The present invention allows the MUAV to be insertable into and ejected from enclosed spaces of the missile both in a close sliding fit. More particularly, the present invention eliminates the problem of limited range by employing a cruise missile to dispense multiple MUAVs. The operation of the present invention may be better understood by first referring to FIG. 1.

[0023] FIG. 1 generally illustrates a cruise missile 10 that has payload bays, such as the known Tomahawk variant UGM 109D cruise missile, which features four payload bays 12₁, 12₂, 12₃,

12₄ displaced about the fuselage of the cruise missile 10. The payload modules 12₁, 12₂, 12₃, 12₄ are enclosed by defined spaces of the Tomahawk missile 10 having predetermined dimensions. The features of the payload modules 12₁, 12₂, 12₃, 12₄ may be further described with reference to FIG. 2 generally illustrating a payload module 12₁.

[0024] As seen in FIG. 2, the payload module, such as 12₁, has six submunition compartments 14₁, 14₂, 14₃, 14₄, 14₅ and 14₆. Each of the six submunition compartments can hold a submunition that is separately ejectable from the defined payload module identified typically at 12₁. In general, the present invention provides a module assembly that allows one submunition to support and dispense multiple micro-unmanned aerial vehicles.

[0025] FIG. 3 and FIG. 4 show the module assembly 16 that has exterior dimensions that substantially match the interior dimensions of one submunition compartment 14₁...14₆. Assembly 16 should have a close, sliding fit within a submunition compartment. This allows assembly 16 to be inserted into and to be ejectable from the enclosed submunition compartment 14₁...14₆. One module assembly 16 can be positioned in each submunition compartment 14₁...14₆. The details of the module assembly 16 of the present invention may be further described with reference to FIG. 4, which is a cross-sectional representation of the module assembly 16 prior to deployment.

[0026] The module assembly 16 comprises a shell 18 which has the substantially same external dimensions as the internal dimensions of submunition payload 14₁...14₆. The shell 18 provides environmental protection to the internal components and acts as a launch platform for MUAVs. These MUAVs are shown in FIG. 4 as MUAV 20₁, 20₂, 20₃ and 20₄. MUAVs can have sensors 21 positioned thereon. MUAVs can be remotely controlled and have transmitters allowing them to transmit sensor signals.

[0027] The internal volume of module assembly can be divided by shell 18 into five compartments 22₁, 22₂, 22₃, 22₄ and 22₅. Compartments 22₁, 22₂, 22₃, and 22₄ can be occupied by a respective MUAV 20₁, 20₂, 20₃ and 20₄. Compartment 22₅ is occupied by a parachute 24.

[0028] Spacers 26₁₁, 26₁₂, 26₂₁, 26₂₂, 26₃₁, 26₃₂, 26₄₁ and 26₄₂, stacked alternately in compartments 22₁, 22₂, 22₃, and 22₄, to hold MUAVs 20₁...20₄. More particularly, compartment 22₁ holds spacer 26₁₁ and 26₁₂, compartment 22₂ holds spacers 26₂₁ and 26₂₂, compartment 22₃ holds spacers 26₃₁ and 26₃₂, and compartment 22₄ holds spacers 26₄₁ and 26₄₂. Each of the spacers 26₁₁...26₄₂ is preferably comprised of an elastomeric material and each pair of spacers 26₁₁ and 26₁₂; 26₂₁ and 26₂₂; 26₃₁ and 26₃₂; and 26₄₁ and 26₄₂ are oppositely facing each other and confine the movement of their respective MUAV 20₁, 20₂, 20₃ and 20₄.

[0029] The fuselage of each MUAV 20₁, 20₂, 20₃ and 20₄ contains a normally closed plunger-type activation switch 28. When compressed by the elastomeric spacers 26₁₁...26₄₂ within the MUAV compartments, the switches 28 remain in the open, or off position. When extended, by the separation of the spacers 26₁₁...26₄₂ and MUAVs, 20₁...20₄ to be further described hereinafter, the switches 28 extend so as to activate the internal propulsion motor of their respective MUAV 20₁...20₄.

[0030] The parachute compartment 22₅ contains the parachute 24, a lanyard 30 and an arming-switch 32. The lanyard 30 attaches to the wall of parachute compartment 22₅, loops under the parachute 24 and exits the compartment 22₅ through a slot 34 in a tear-through cover 36 of the compartment 22₅. The tear-through cover 36 holds the parachute 24 in the compartment 22₅ prior to deployment to be further described hereinafter. Both the parachute 24 and the arming-switch 32 are secured to the lanyard 30.

[0031] The module assembly 16 shown in FIG. 4 further comprises a control unit 38 and a battery 40. The control unit 38 provides all internal control for the module assembly 16 and has timing means for ejecting the respective module assembly 16 from the submunition compartment 14 at selectable times. Assembly 16 ejection can also be controlled by remote communication from a support platform. The battery 40 provides

all of the internal power necessary to operate the module assembly 16.

[0032] The module assembly 16, in particular the shell 18, has walls with four-spaced apart corners 42₁, 42₂, 42₃, and 42₄ each having a latch 44. The latches 44 operate in their off-state to hold the walls of the shell 18 together and when in their on-state cause the walls to separate from each other. The latches 44 can be pyro-activated devices. When activated (on-state), the latches 44 allow complete separation of the walls of the shell 18.

[0033] The launching platform plots waypoints for a flight path over the desired area, or areas, and launches the cruise missile 10 outfitted with module assembly 16 shown in FIGS. 3 and 4. FIG. 5 shows an example mission profile 46. More particularly, FIG. 5 illustrates the mission profile 46 as including an initial position 48 of the cruise missile 10 and a final position 50 of the cruise missile 10. The mission profile 46 further includes multiple waypoints 52. The cruise missile can eject one module assembly 16 between waypoints 52. Further details of the operation of the present invention may be described with reference to FIG. 6.

[0034] FIG. 6 generally illustrates the payload module 12₁, previously discussed with reference to FIG. 2. FIG. 6 further

illustrates the module assembly 16 described with reference to FIGS. 3 and 4, ejected from the submunition compartment 14₁.

[0035] FIG. 6 further illustrates the payload module 12₁ as housing module assemblies 16 in submunition compartments 14₁, 14₂, 14₄, 14₅ and 14₆ of FIG. 2. The location for submunition compartments 14₃ and 14₄ is shown as being partially broken away so as to illustrate further details of both the payload module 12₁ and the module assembly 16.

[0036] As seen in FIG. 6, the module assembly 16 has tear-through cover 36 (previously discussed with reference to FIG. 4) that allows the exit of the lanyard 30 from opening 34 (both previously discussed with reference to FIG. 4). The lanyard 30 has a weak point 56 (to be further described with reference to FIGS. 7 and 8) and has its distal end attached to latch 58 of the payload module 12₁.

[0037] As further seen in FIG. 6, the payload module 12₁ comprises control lines 60, closure doors 62, and hinges 64 operatively cooperating with respective closure doors 62, and mounting lugs 66. Prior to deployment, the exterior surface of assembly 16 acts as the exterior surface of missile 10. After deployment, closure door 62 must be moved into place in order to preserve missile 10's aerodynamic characteristics.

[0038] FIG. 6 primarily illustrates the status of the module assembly 16 just after ejection. The module assembly 16

operation during and after ejection, is similar to the operation of known systems such as that used on the Tomahawk cruise missile variant UGM-109D. Unlike the known system, the current invention allows ejection of less than all of the module assemblies.

[0039] Upon ejection, the lanyard 30, of the present invention, tethers the module assembly 16 that is ejected to the respective payload module closure door 62. As seen with simultaneous reference to FIGS. 6 and 7, when taut, the lanyard 30 pulls the respective closure door 62 shut, while simultaneously forcing the parachute 24 through the tear-through cover 36 and also pulling the pin 68 on the arming switch 32 thereby activating the control unit 38.

[0040] With the closure door 62 shut and the parachute 24 clear of the module assembly 16, as seen in FIG. 7, the lanyard 30 breaks at the weak-point 56 leaving the module assembly 16 to fall and deploy the parachute 24. A closure door latch 58, shown in FIG. 6, holds the closure door 62 closed. Once closed and latched, the closure door 62 aerodynamically fairs with the airframe of the missile 10 for the rest of the flight shown in FIG. 5.

[0041] With the parachute 24 deployed, as shown in FIG. 8, the module assembly 16 floats toward earth. After a brief delay, when the module assembly 16 reaches a pre-programmed

altitude, or on remote command, the control unit 38 fires the latches 44 thereby separating the walls of the shell 18. Falling free of the module assembly 16, the stacked MUAVs 20₁, 20₂, 20₃, and 20₄ separate from their elastomeric isolators 26₁₁...26₄₂ extending their activation switches 28 and starting the respective motors enclosed in the MUAVs 20₁, 20₂, 20₃, and 20₄.

[0042] It should now be appreciated that the practice of the present invention provides a module assembly 16 that adapts a system employed for dispensing submunitions from a cruise missile to a micro-unmanned aerial vehicle system having a limited range capability. The module assembly 16 allows the range of the system to be increased to that of the range utilized by the cruise missile, while at the same time providing for the proper dispensing of submunitions, that is, MUAVs.

[0043] It should be further appreciated that although the invention has been described for adapting the utilization of Tomahawk missile to the needs of a weapon system employing MUAVs other vehicles such as those found in airborne applications may be utilized to increase the present limited operating range of the weapon systems employing MUAVs.

[0044] It will be understood that many additional changes in the details, materials, steps and arrangement of parts, which have been herein described and illustrated in order to explain the nature of the invention, may be made by those skilled in the

art within the principle and scope of the expressed in the
appended claims.

MICRO-UNMANNED AERIAL VEHICLE DEPLOYMENT SYSTEM

ABSTRACT OF THE DISCLOSURE

A micro-unmanned aerial vehicle deployment system is provided for a cruise missile having submunition compartments. The system includes a vehicle launch module releasable from the cruise missile submunition compartment. The vehicle launch system has a control circuit and at least one micro-unmanned aerial vehicle contained therein. Structure is provided in the launch module for deploying the micro-unmanned aerial vehicle. A separable tether can be joined between the cruise missile and the vehicle launch module that separates when subjected to tension after deployment of the vehicle launch module.

FIG-1

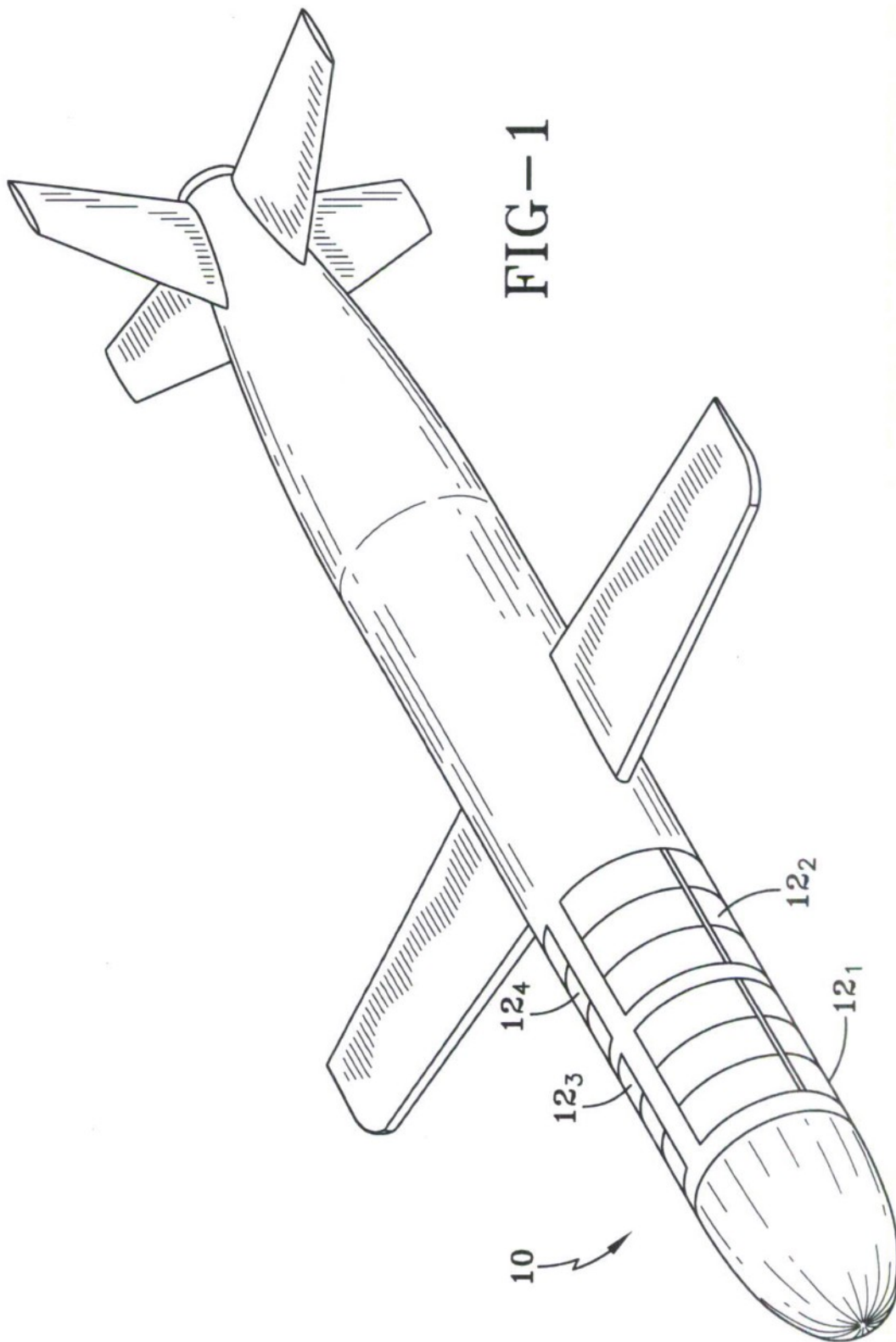

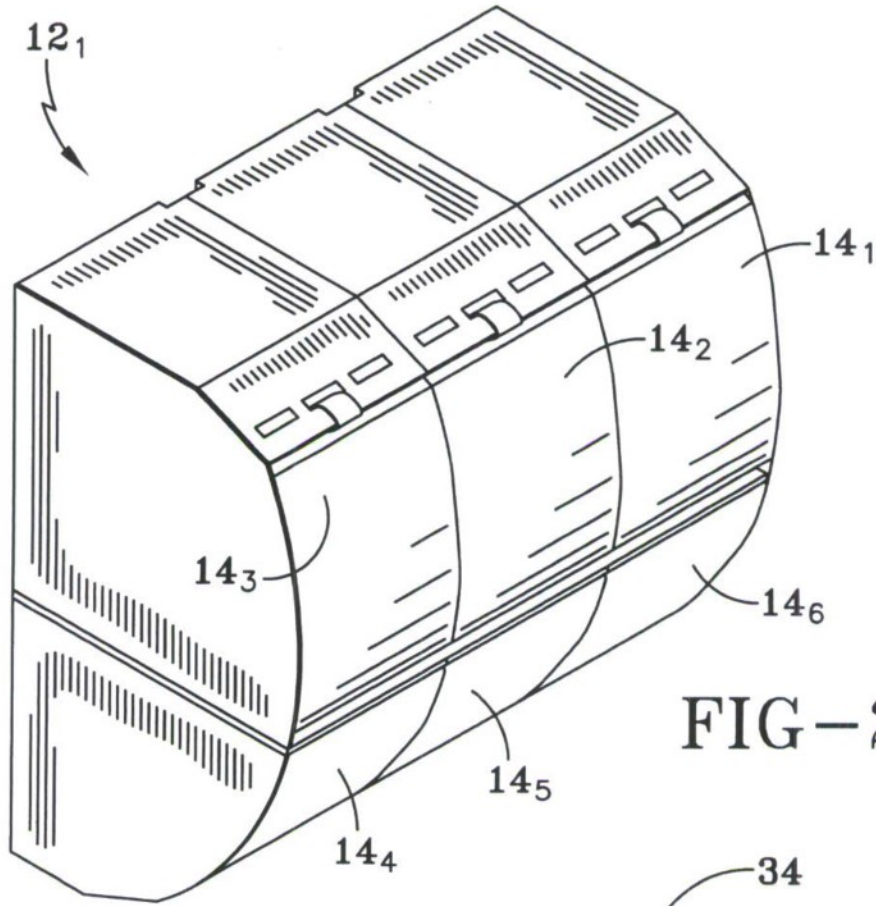

FIG-2

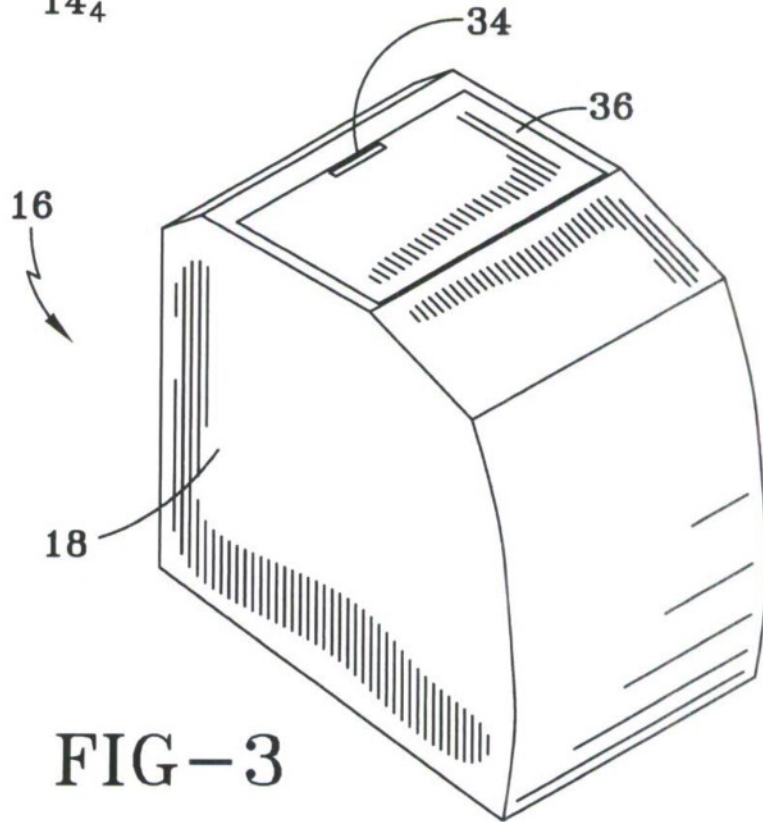

FIG-3

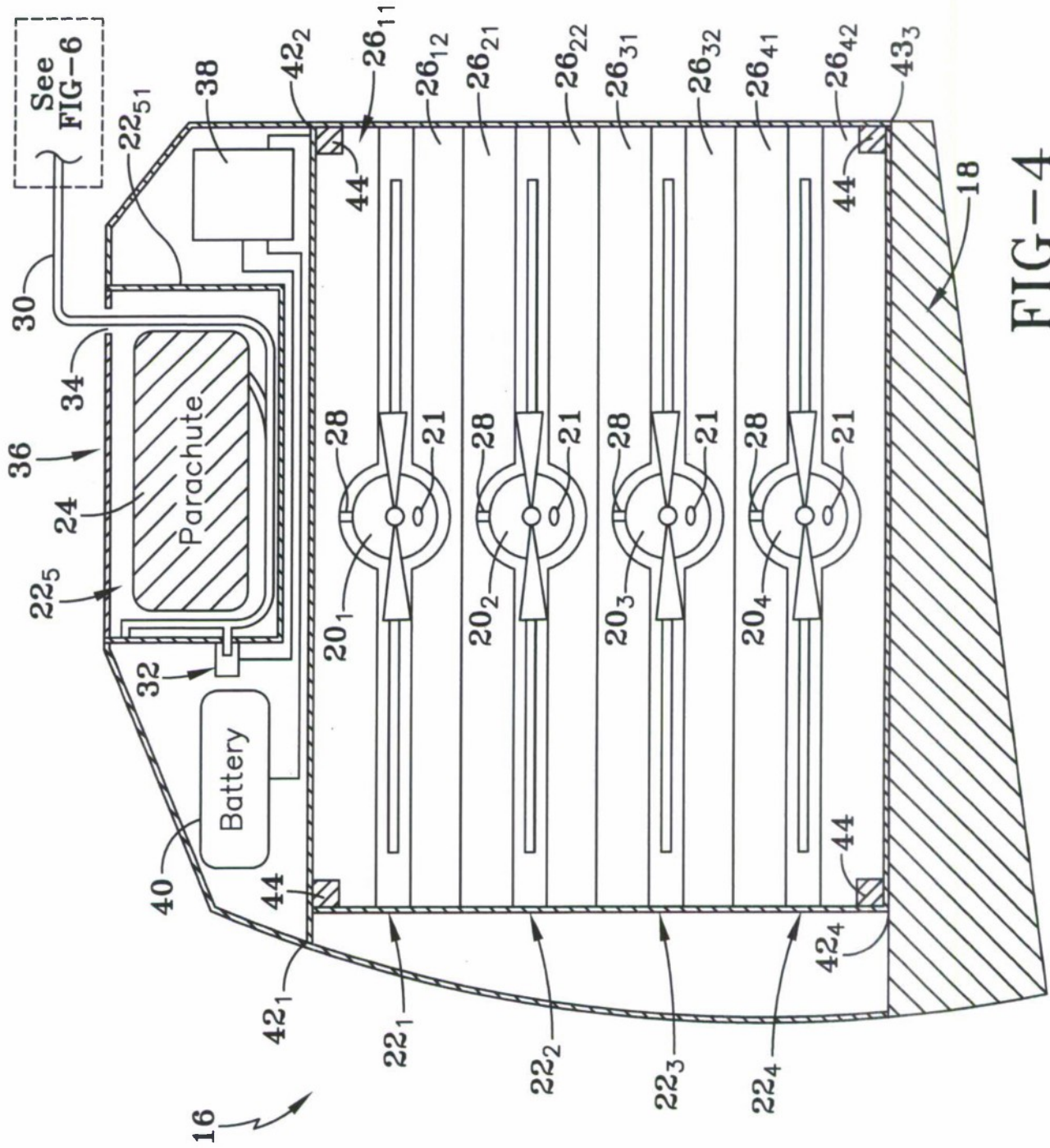

FIG-4

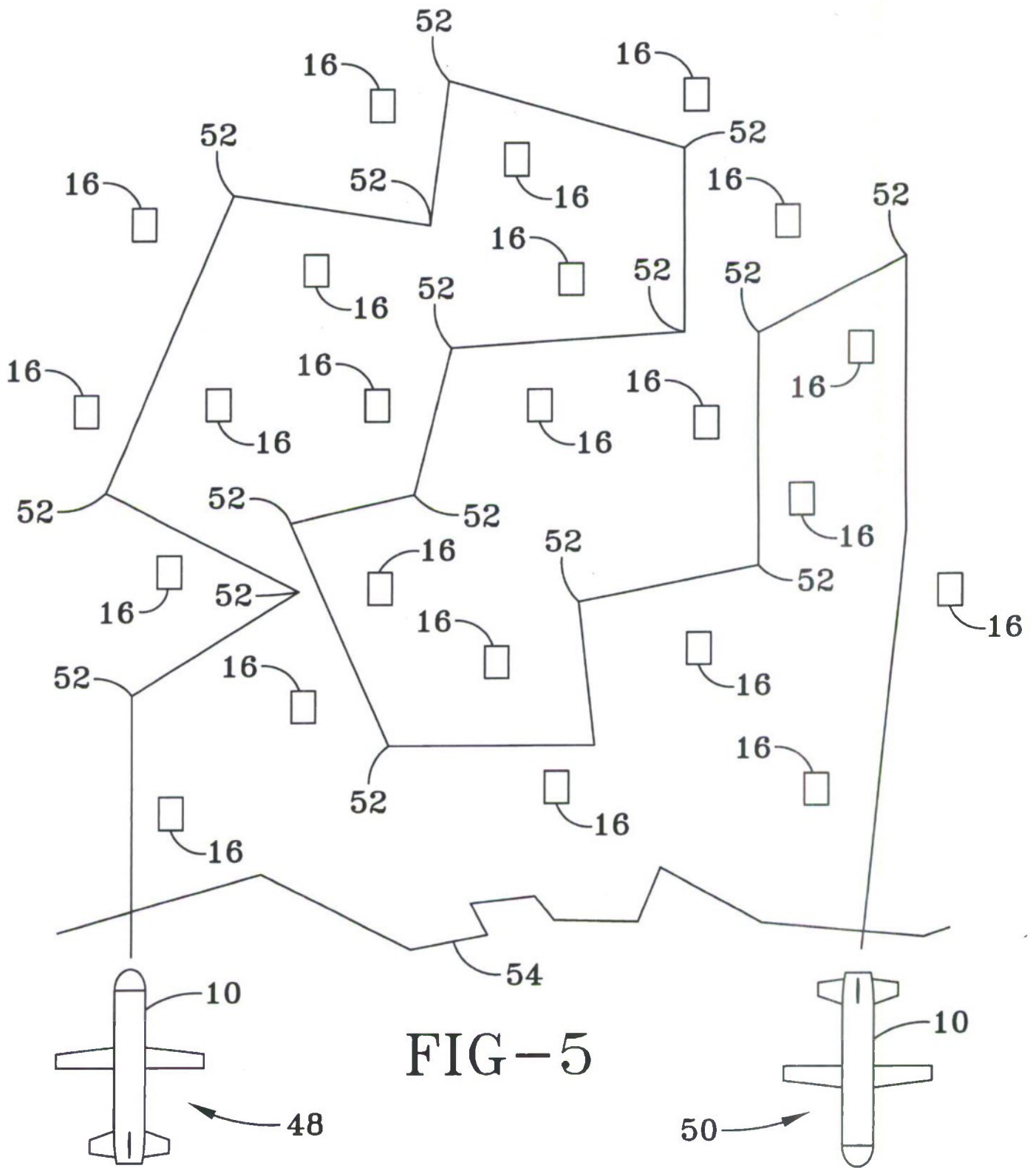

FIG-5

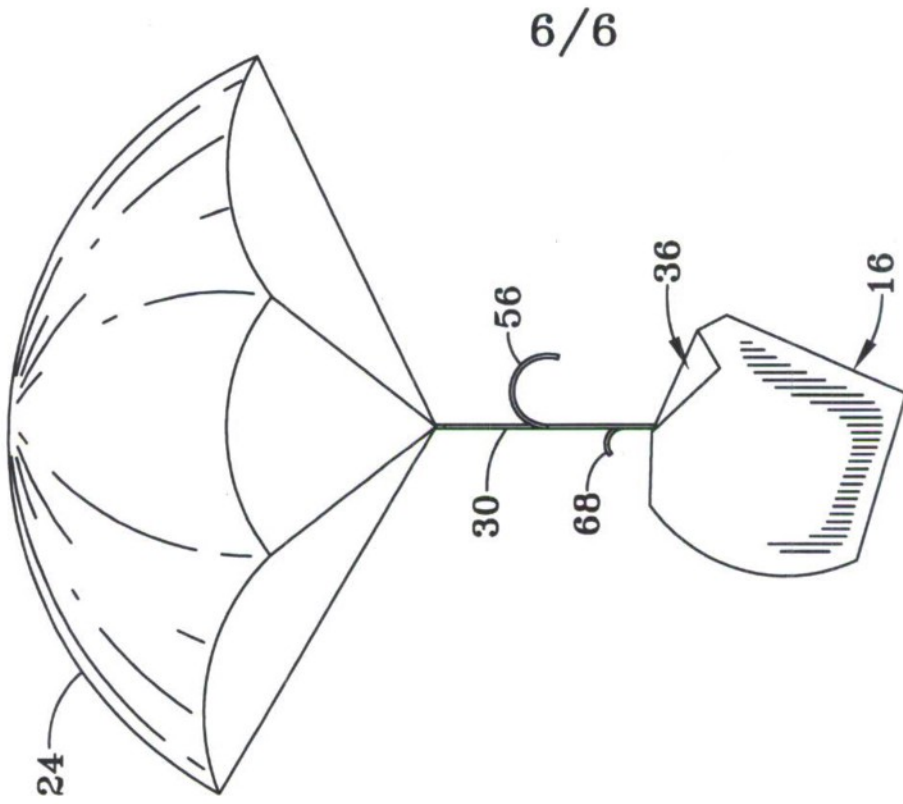

FIG-8

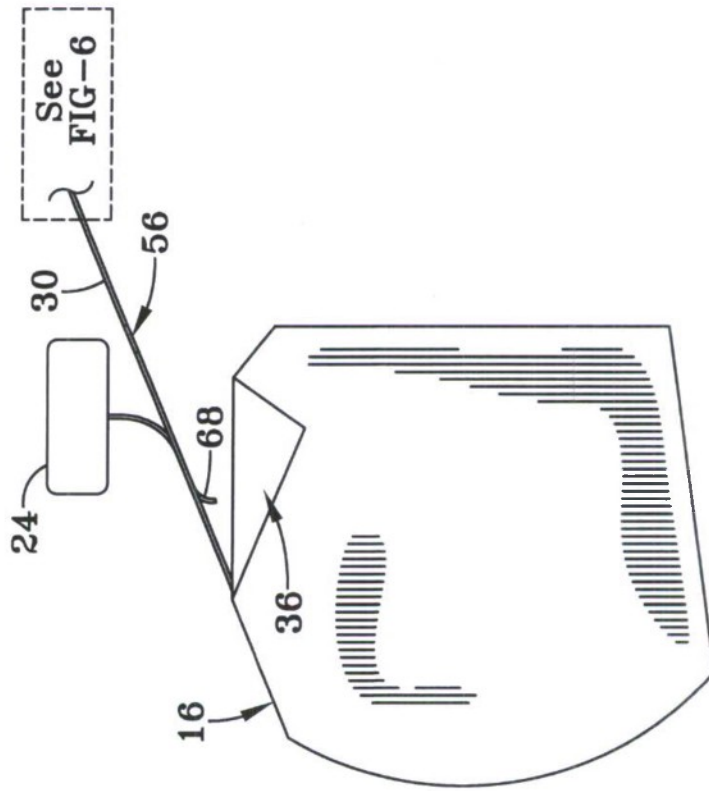

FIG-7