



US00D626118S

(12) **United States Design Patent**
Schmitz

(10) **Patent No.:** **US D626,118 S**

(45) **Date of Patent:** **** Oct. 26, 2010**

(54) **BIDIRECTIONAL TILT ANTENNA MOUNT**

(75) Inventor: **John J. Schmitz**, Macomb, MI (US)

(73) Assignee: **The United States of America as represented by the Secretary of the Army**, Washington, DC (US)

(**) Term: **14 Years**

(21) Appl. No.: **29/363,100**

(22) Filed: **Jun. 4, 2010**

(51) **LOC (9) Cl.** **14-03**

(52) **U.S. Cl.** **D14/238**

(58) **Field of Classification Search** D14/230-238, D14/354, 299, 358; D6/495; D16/242; 343/700 R, 343/878-892; 455/561

See application file for complete search history.

(56) **References Cited**

U.S. PATENT DOCUMENTS

2,504,458 A * 4/1950 Schmidt et al. 244/102 SL

(Continued)

Primary Examiner—Celia A Murphy

Assistant Examiner—John Windmuller

(74) *Attorney, Agent, or Firm*—David L. Kuhn; Thomas W. Saur; Luis Miguel Acosta

(57) **CLAIM**

The ornamental design for a bidirectional tilt antenna mount, as shown and described.

DESCRIPTION

The invention described here may be made, used and licensed by and for the U.S. Government for governmental purposes without paying royalty to me.

FIG. 1 is a front, left, top isometric view of a bidirectional tilt antenna mount in an un-tilted position (the right side view being a mirror of the left and is not illustrated);

FIG. 2 is a front, left, bottom isometric view of the bidirectional tilt antenna mount in an un-tilted position (the right side view being a mirror of the left and is not illustrated);

FIG. 3 is a front elevation view of the bidirectional tilt antenna mount;

FIG. 4 is a rear elevation view of the bidirectional tilt antenna mount;

FIG. 5 is a top plan view of the bidirectional tilt antenna mount;

FIG. 6 is a bottom plan view of the bidirectional tilt antenna mount;

FIG. 7 is a left side elevation view of the bidirectional tilt antenna mount (the right side elevation view being a mirror of the left and is not illustrated);

FIG. 8 is a front, left, top isometric view of the bidirectional tilt antenna mount, wherein the bidirectional tilt antenna mount fully tilted in a first direction is illustrated (the right side view being a mirror of the left and is not illustrated);

FIG. 9 is a rear, left, top isometric view of the bidirectional tilt antenna mount, wherein the bidirectional tilt antenna mount fully tilted in a second direction is illustrated (the right side view being a mirror of the left and is not illustrated);

FIG. 10 is a front, left, top isometric view of the bidirectional tilt antenna mount, wherein the bidirectional tilt antenna mount fully tilted in the second direction is illustrated (the right side view being a mirror of the left and is not illustrated);

FIG. 11 is a left side elevation view of the bidirectional tilt antenna mount, wherein the bidirectional tilt antenna mount fully tilted in the second direction is illustrated (the right side elevation view being a mirror of the left and is not illustrated);

FIG. 12 is a left side elevation view of the bidirectional tilt antenna mount, wherein the bidirectional tilt antenna mount fully tilted in the first direction is illustrated (the right side elevation view being a mirror of the left and is not illustrated); and

FIG. 13 is a front, top, and right side perspective view of the bidirectional tilt antenna mount, wherein the mount in an un-tipped, upright position, and implemented in a typical environment is illustrated.

Views are orthogonal projections unless otherwise noted. The broken line showing of FIG. 13 is included for the purpose of illustrating environment and forms no part of the claimed design.

1 Claim, 11 Drawing Sheets

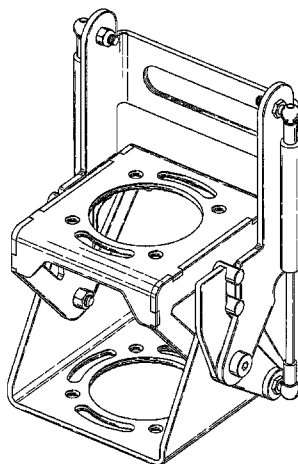

Report Documentation Page

Form Approved
OMB No. 0704-0188

Public reporting burden for the collection of information is estimated to average 1 hour per response, including the time for reviewing instructions, searching existing data sources, gathering and maintaining the data needed, and completing and reviewing the collection of information. Send comments regarding this burden estimate or any other aspect of this collection of information, including suggestions for reducing this burden, to Washington Headquarters Services, Directorate for Information Operations and Reports, 1215 Jefferson Davis Highway, Suite 1204, Arlington VA 22202-4302. Respondents should be aware that notwithstanding any other provision of law, no person shall be subject to a penalty for failing to comply with a collection of information if it does not display a currently valid OMB control number.

1. REPORT DATE 26 OCT 2010	2. REPORT TYPE N/A	3. DATES COVERED -			
4. TITLE AND SUBTITLE Bidirectional Tilt Antenna Mount		5a. CONTRACT NUMBER			
		5b. GRANT NUMBER			
		5c. PROGRAM ELEMENT NUMBER			
6. AUTHOR(S) John J. Schmitz		5d. PROJECT NUMBER			
		5e. TASK NUMBER			
		5f. WORK UNIT NUMBER			
7. PERFORMING ORGANIZATION NAME(S) AND ADDRESS(ES) US Army RDECOM-TARDEC 6501 E 11 Mile Rd Warren, MI 48397-5000, USA		8. PERFORMING ORGANIZATION REPORT NUMBER 21393			
9. SPONSORING/MONITORING AGENCY NAME(S) AND ADDRESS(ES)		10. SPONSOR/MONITOR'S ACRONYM(S) TACOM/TARDEC			
		11. SPONSOR/MONITOR'S REPORT NUMBER(S) 21393			
12. DISTRIBUTION/AVAILABILITY STATEMENT Approved for public release, distribution unlimited					
13. SUPPLEMENTARY NOTES Patent No.: US D626,118 S					
14. ABSTRACT					
15. SUBJECT TERMS					
16. SECURITY CLASSIFICATION OF:			17. LIMITATION OF ABSTRACT SAR	18. NUMBER OF PAGES 13	19a. NAME OF RESPONSIBLE PERSON
a. REPORT unclassified	b. ABSTRACT unclassified	c. THIS PAGE unclassified			

US D626,118 S

Page 2

U.S. PATENT DOCUMENTS

2,667,317	A *	1/1954	Trebules	248/514	7,115,828	B2 *	10/2006	McCord et al.	200/400
4,093,953	A	6/1978	Hammons et al.		7,408,526	B2 *	8/2008	Pan	343/880
4,101,897	A *	7/1978	Morrison	343/715	7,513,456	B2	4/2009	Lindahl	
4,489,304	A	12/1984	Hayes		D593,079	S	5/2009	Schmitz et al.	
4,490,726	A *	12/1984	Weir	343/840	D611,461	S *	3/2010	Schmitz et al.	D14/238
4,738,423	A *	4/1988	DiFilippo et al.	248/311.2	2001/0028327	A1 *	10/2001	Yamamoto et al.	343/757
5,506,593	A	4/1996	Peng		2002/0135531	A1 *	9/2002	Ehrenberg et al.	343/878
6,042,068	A *	3/2000	Tcherny	248/221.11	2007/0052604	A1 *	3/2007	Young et al.	343/757
6,484,987	B2 *	11/2002	Weaver	248/278.1	2007/0132655	A1 *	6/2007	Lin	343/880
6,791,501	B2 *	9/2004	Maeda et al.	343/715	2008/0165076	A1 *	7/2008	Pan	343/882
6,906,673	B1 *	6/2005	Matz et al.	343/760	2009/0283944	A1 *	11/2009	Schordine	267/140.11

* cited by examiner

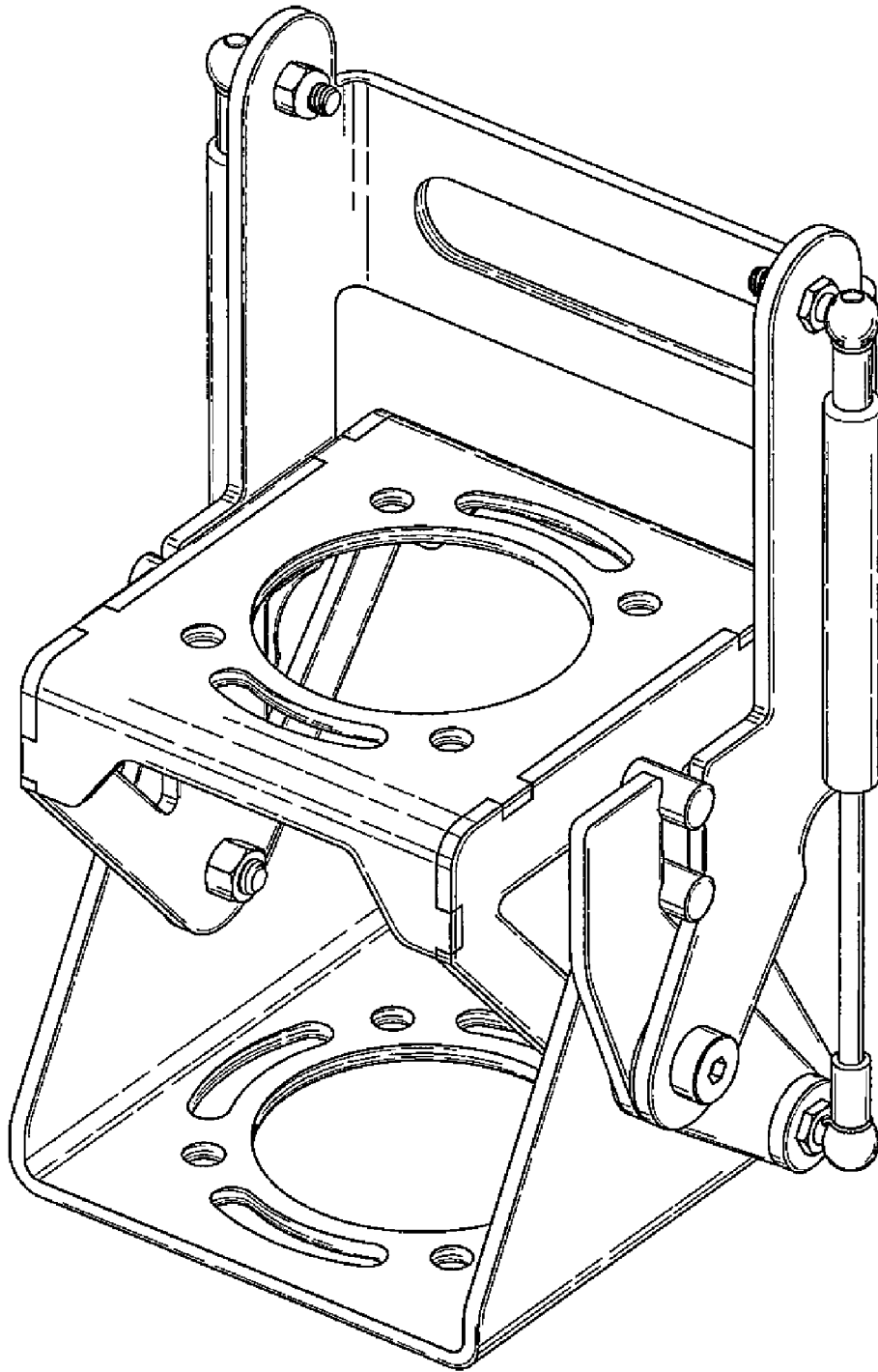

FIG. 1

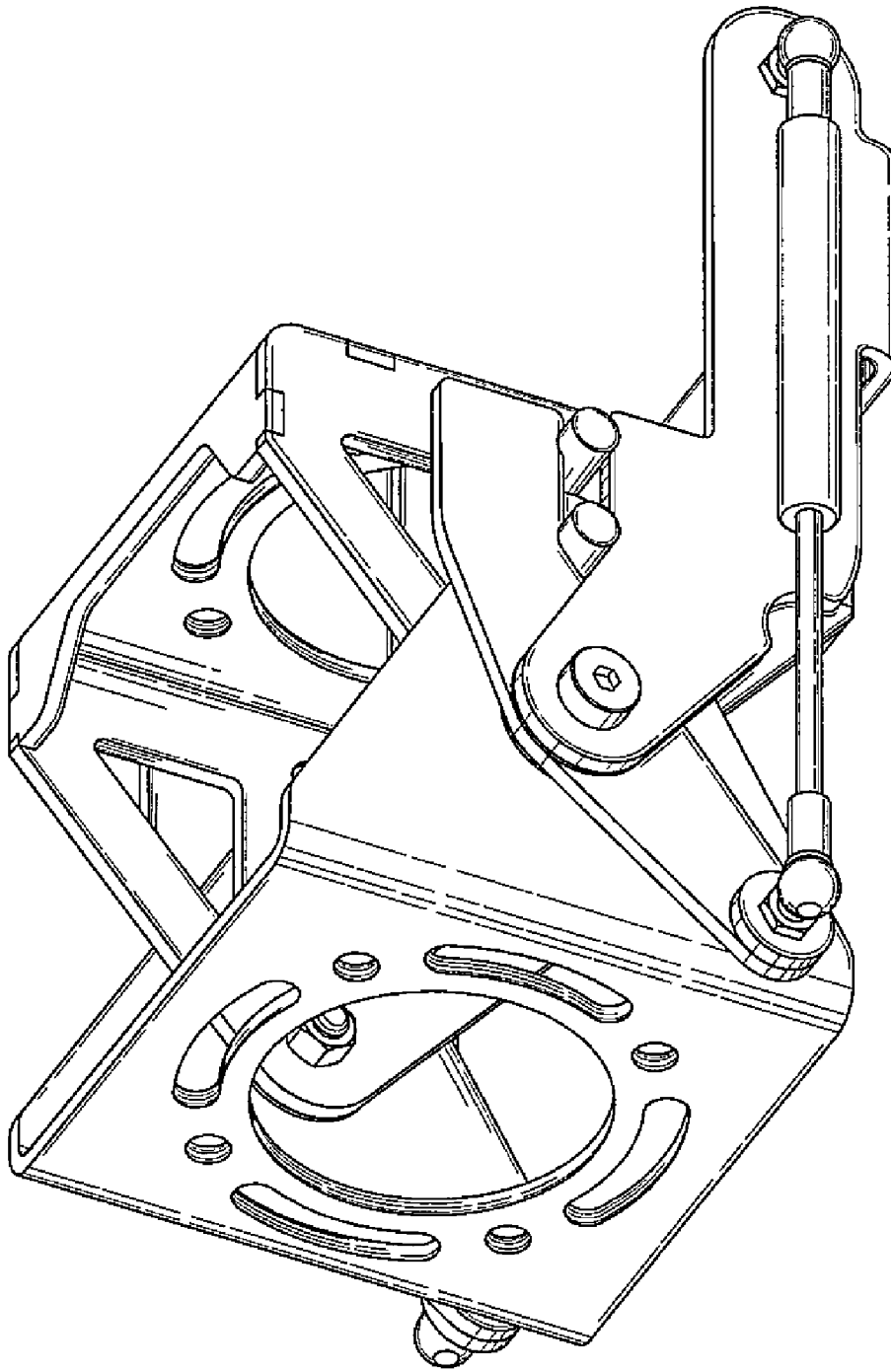

FIG. 2

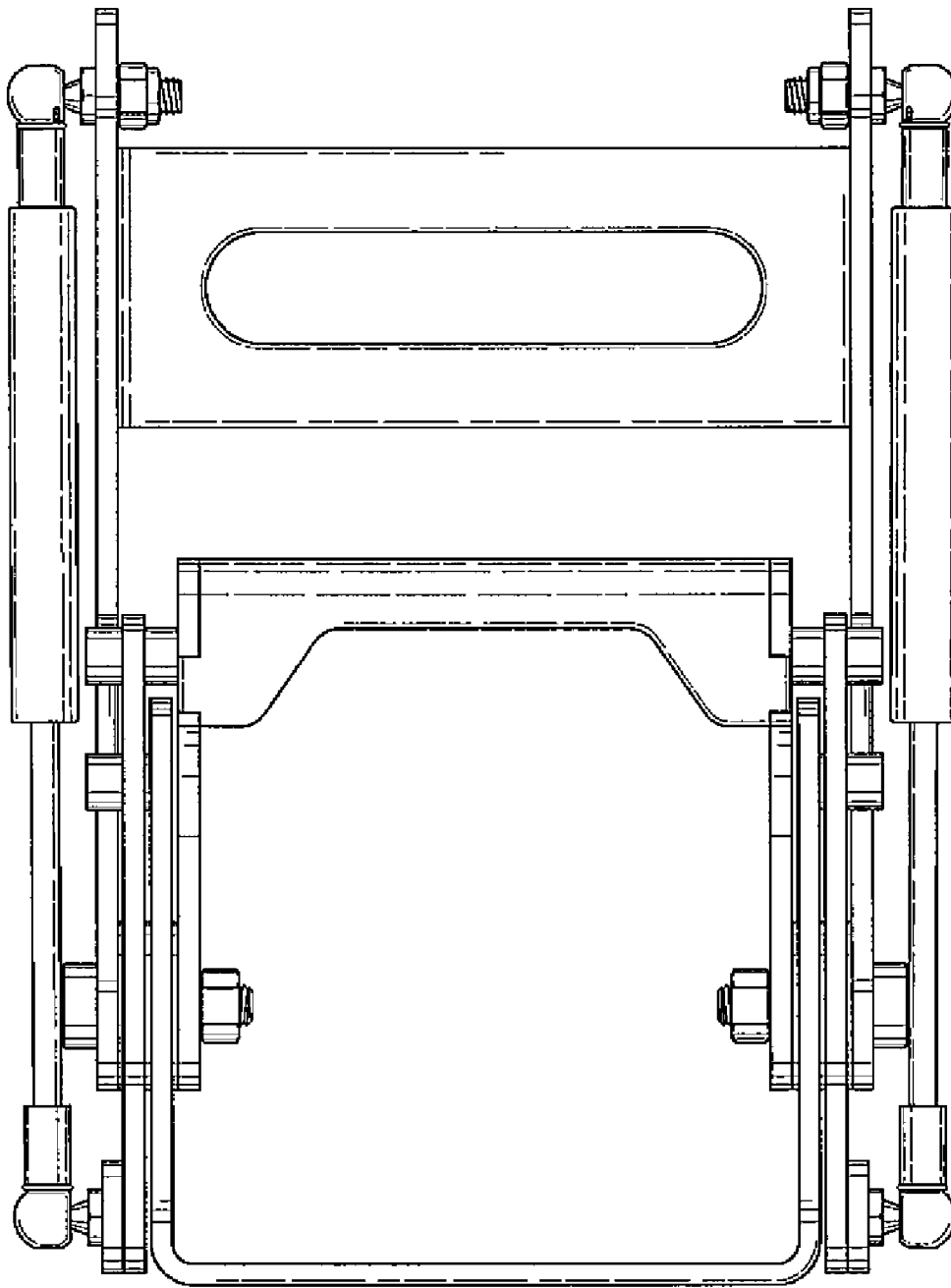

FIG. 3

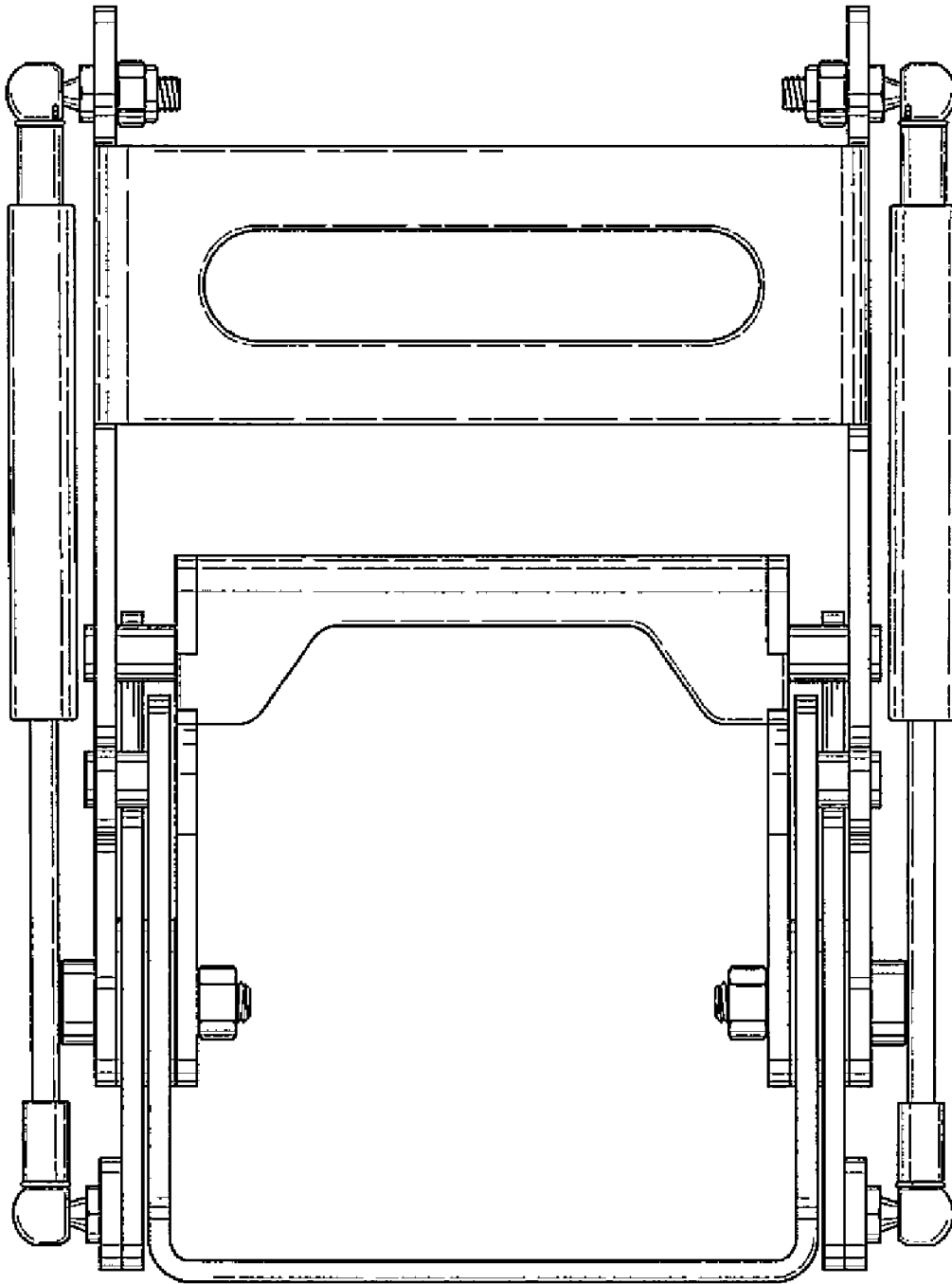

FIG. 4

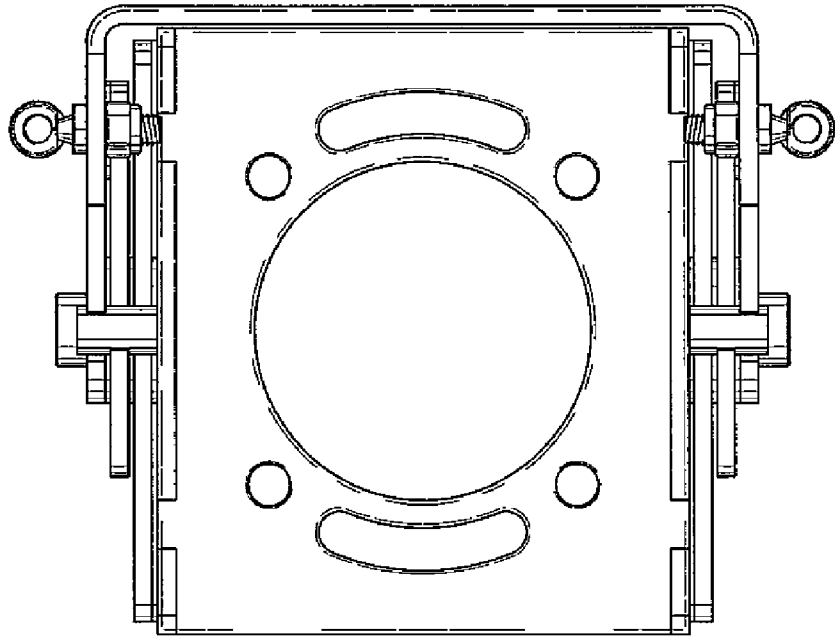

FIG. 5

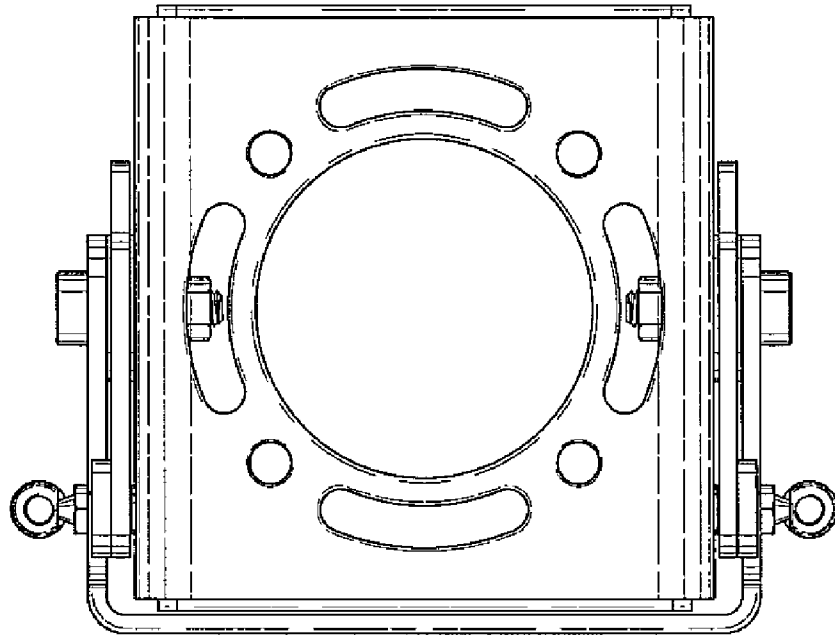

FIG. 6

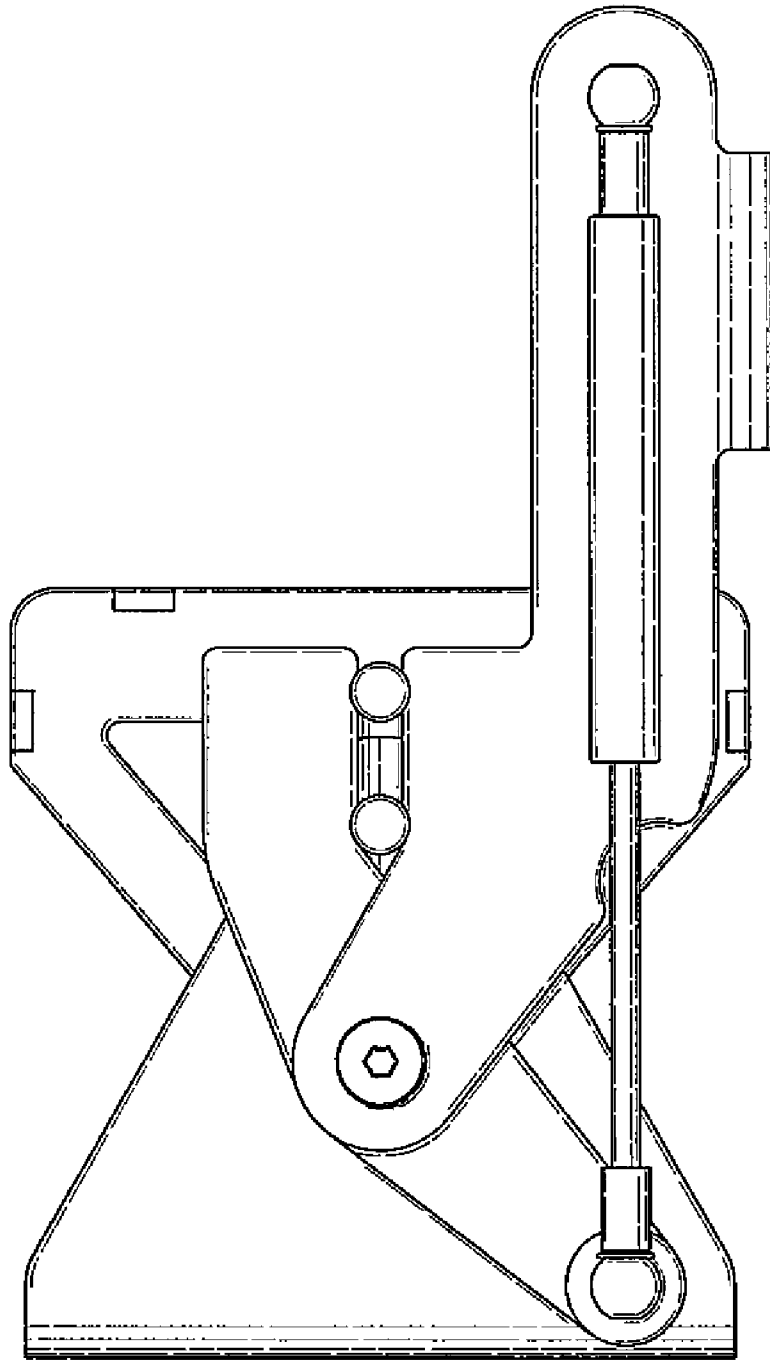

FIG. 7

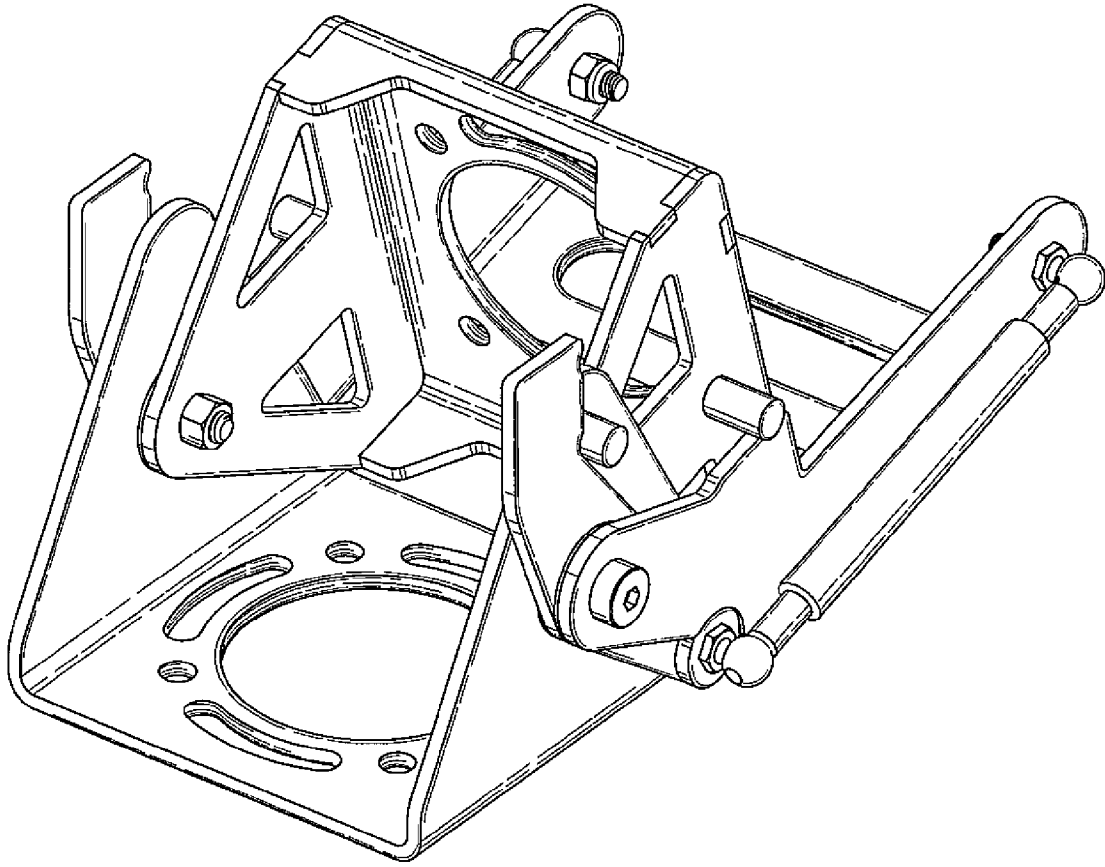

FIG. 8

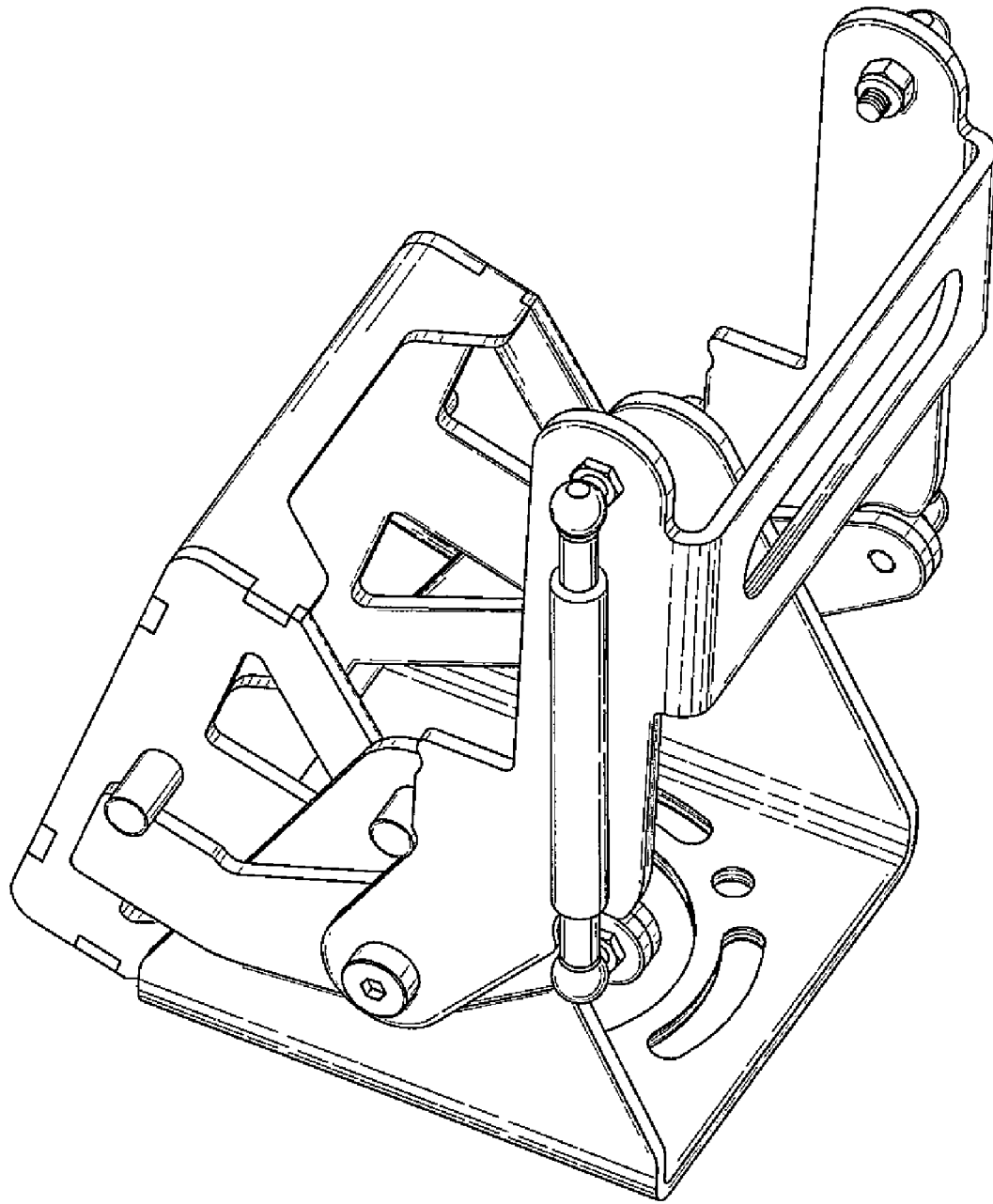

FIG. 9

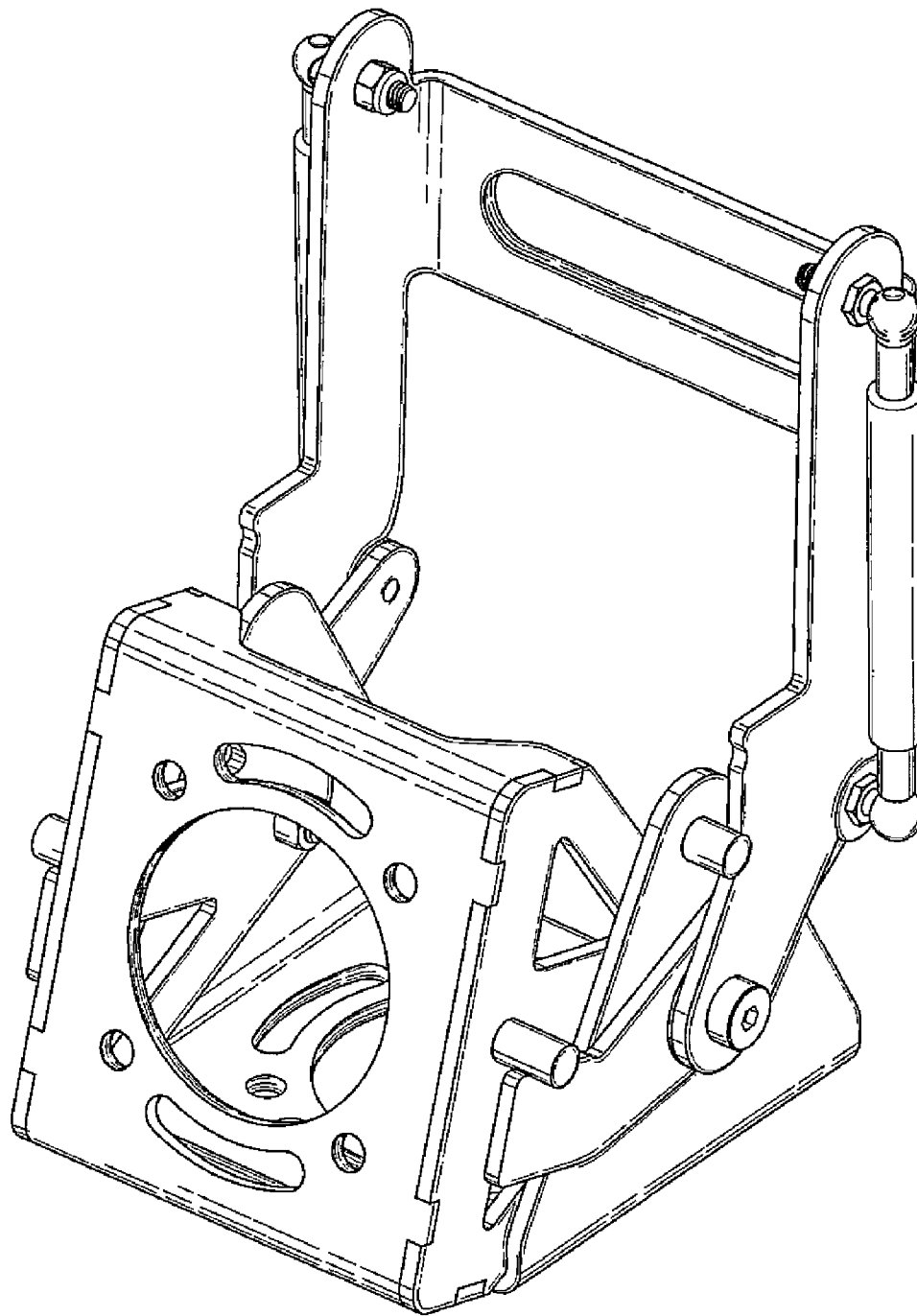

FIG. 10

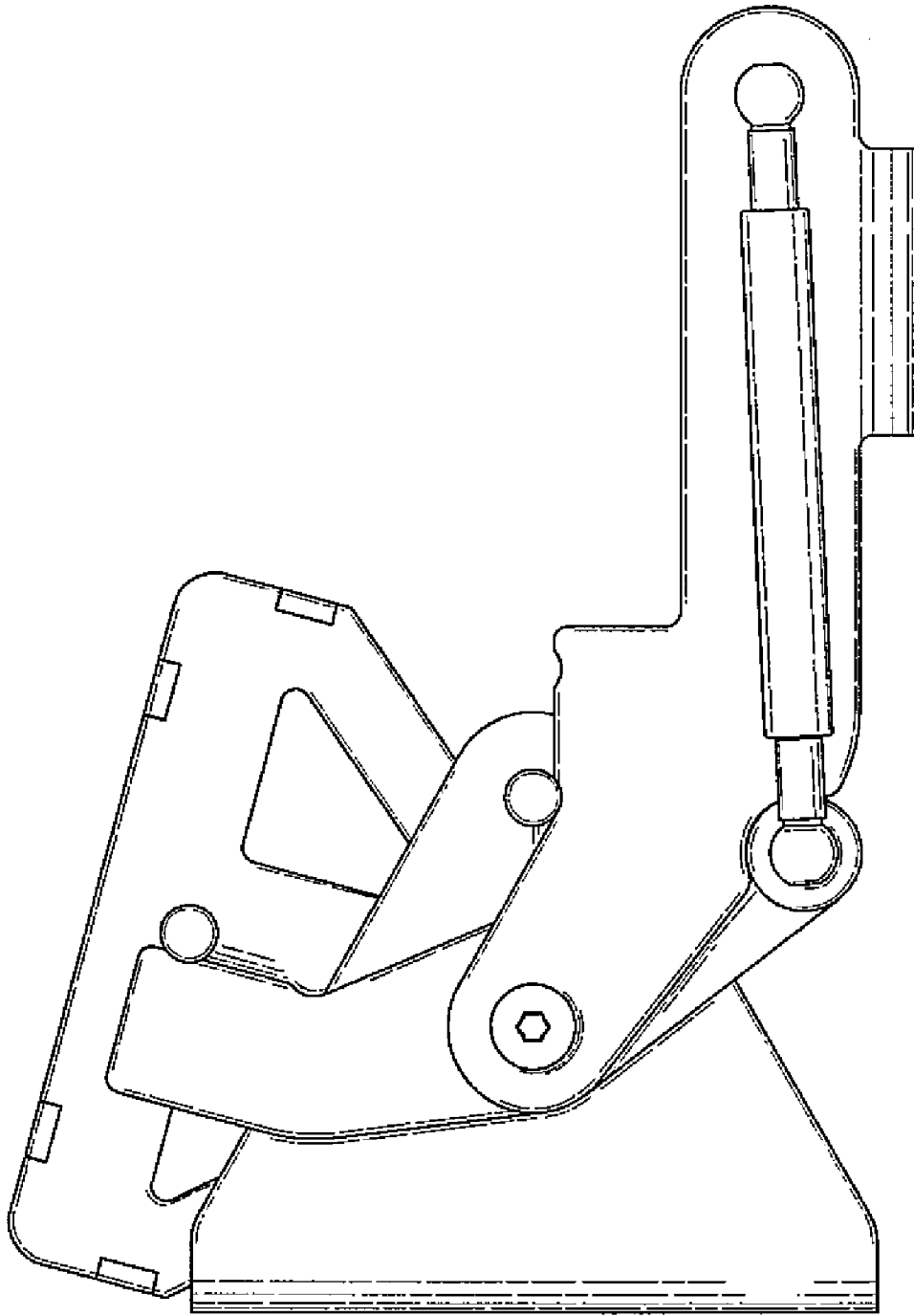

FIG. 11

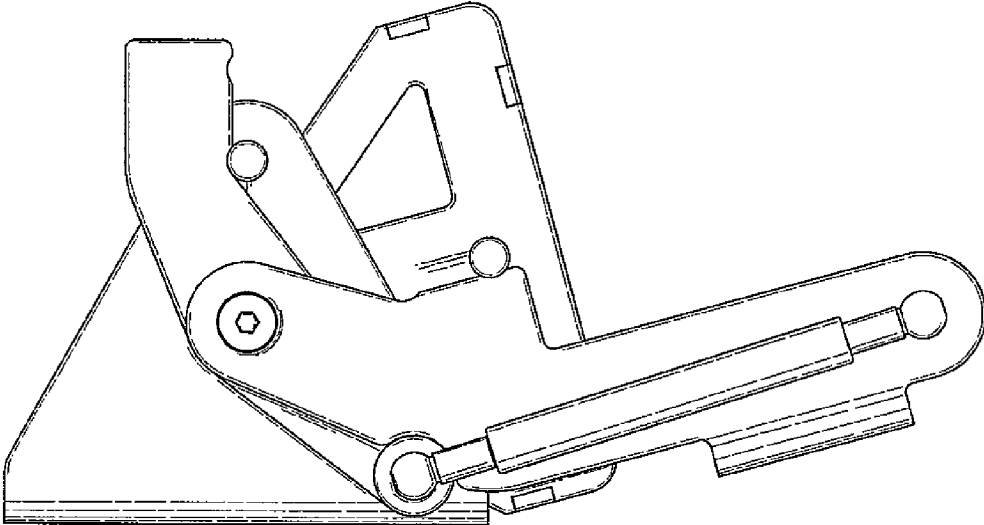

FIG. 12

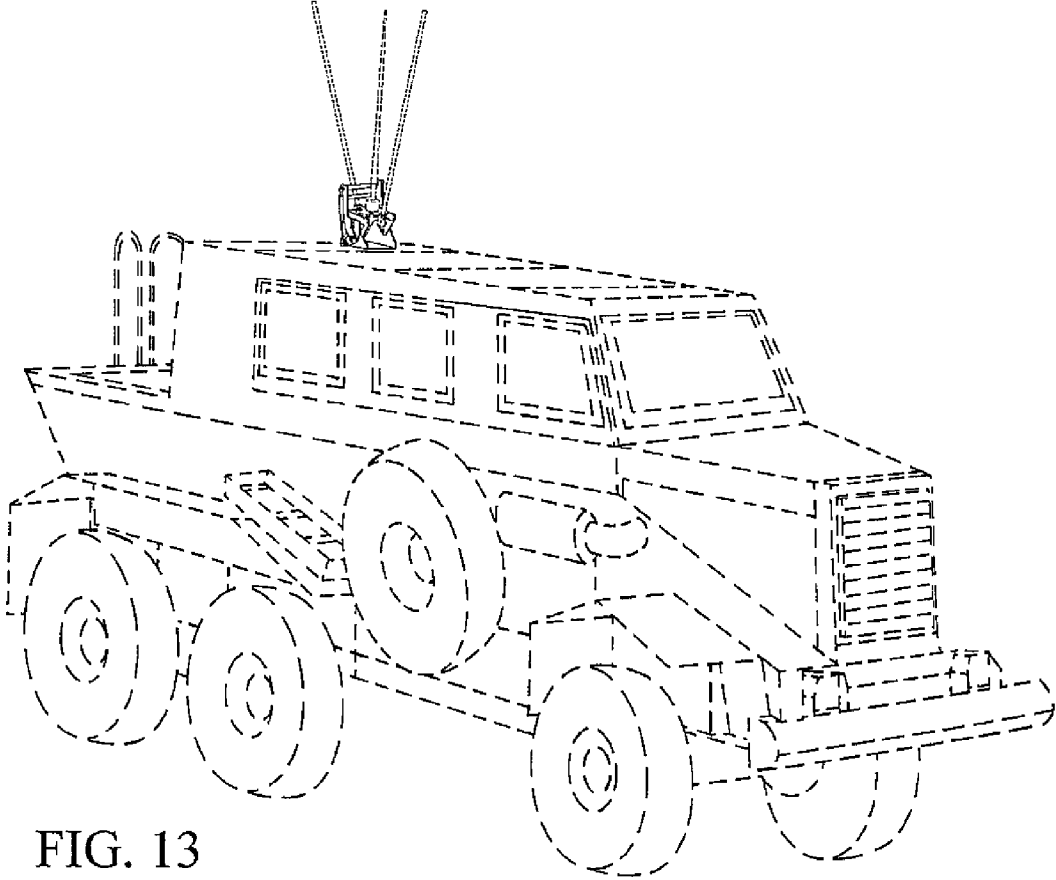

FIG. 13