



DEPARTMENT OF THE NAVY
NAVAL UNDERSEA WARFARE CENTER
DIVISION NEWPORT
OFFICE OF COUNSEL
PHONE: 401 832-3653
FAX: 401 832-4432
DSN: 432-3653



Attorney Docket No. 99298
Date: 16 December 2009

The below identified patent application is available for licensing. Requests for information should be addressed to:

TECHNOLOGY PARTNERSHIP ENTERPRISE OFFICE
NAVAL UNDERSEA WARFARE CENTER
1176 HOWELL ST.
CODE 07TP, BLDG. 990
NEWPORT, RI 02841

Serial Number 12/587,328
Filing Date 30 September 2009
Inventor David F. Rivera

Address any questions concerning this matter to the Office of Technology Transfer at (401) 832-1511.

20091222026

DISTRIBUTION STATEMENT
Approved for Public Release
Distribution is unlimited

PARALLEL PLATE ANTENNA

STATEMENT OF GOVERNMENT INTEREST

[0001] The invention described herein may be manufactured and used by or for the Government of the United States of America for governmental purposes without the payment of any royalties thereon or therefore.

CROSS REFERENCE TO OTHER PATENT APPLICATIONS

[0002] None.

BACKGROUND OF THE INVENTION

(1) FIELD OF THE INVENTION

[0003] The present invention is directed to compact antennas. In particular, the present invention is directed to a compact antenna that has the ability to operate on or near electrically conducting surfaces.

(2) DESCRIPTION OF THE PRIOR ART

[0004] The shielding effectiveness (SE) of a metallic enclosure is an important figure of merit that describes the degree of protection against electromagnetic field leakage into

or out of the structure. It is defined by a ratio in dB units by equation (1) as follows:

$$\widetilde{SE} = 20 \log \left| \frac{E_t}{E_i} \right| \quad (1)$$

Where E_t is the electric field strength leaking into the shield, and E_i is the incident field strength external to the shield. Both field strengths have units of volts per meter (V/m). The degree of protection against electromagnetic field leakage is particularly relevant to compact antennas whose design are in the nature of portable metallic enclosures and whose application requires the ability to operate on or near electrically conducting surfaces.

SUMMARY OF THE INVENTION

[0005] It is a general purpose and object of the present invention to provide an antenna design that operates on or near electrically conducting surfaces.

[0006] The above object is accomplished with the present invention through the use of a parallel plate antenna having a number of stacked horizontal plates and two vertical plates. Alternating ones of the horizontal plates are electrically coupled to one of the vertical plates such that the horizontal plates coupled to one vertical plate are interleaved with the horizontal plates coupled to the other vertical plate. The

assembled antenna is mounted on a planar mounting flange. The height/width of the antenna is approximately $1/30^{\text{th}}$ of a wavelength at the frequency of operation.

BRIEF DESCRIPTION OF THE DRAWINGS

[0007] A more complete understanding of the invention and many of the attendant advantages thereto will be more readily appreciated by referring to the following detailed description when considered in conjunction with the accompanying drawings, wherein like reference numerals refer to like parts and wherein:

[0008] FIG. 1 illustrates a perspective view of the present invention antenna;

[0009] FIG. 2 illustrates a side view of the present invention antenna that includes details of the coaxial feed;

[0010] FIG. 3 illustrates an approximate electrical equivalent circuit of the present invention antenna;

[0011] FIG. 4 illustrates the X-Y plane radiation pattern of the present invention antenna according to the orientation of the antenna in FIG. 1;

[0012] FIG. 5 illustrates the antenna of the present invention situated on a conducting plane;

[0013] FIG. 6 illustrates the X-Y plane radiation pattern of the antenna situated on a conducting plane; and

[0014] FIG. 7 illustrates the Y-Z plane radiation pattern of the antenna situated on a conducting plane.

DETAILED DESCRIPTION OF THE INVENTION

[0015] Referring to FIG. 1 and 2 there is illustrated multiple views of the antenna 10 of the present invention. The antenna 10 is comprised of multiple conducting plates arranged in parallel both horizontally and vertically and referred to as horizontal plates 14 and vertical plates 16. The conducting plates 14 and 16 can be made from a conducting metal such as copper or a plastic material that is then plated with electrically conducting material. The height and width of the antenna 10 is approximately one-thirtieth of a wave length ($w \approx h \approx \lambda/30$) at a selected frequency of operation. The depth of the antenna is also of the same proportions relative to the wavelength, that is ($d \approx \lambda/30$). In a preferred embodiment the multiple conducting plates that are arranged horizontally 14 and parallel to each other are all rectangular shape and have the same spatial dimensions. In a preferred embodiment, the two vertical plates 16 are parallel to each other and are rectangular in shape. However, one is slightly larger than the other. The smaller vertical plate 16a allows for an aperture 24 at the top of the antenna 10. The horizontal plates 14 are connected at right angles alternately on each side of and

between the two parallel vertical plates 16. The horizontal plates 14 are spaced an equal distance apart from each other. The horizontal plates 14 serve to tune the antenna 10 to the selected operating frequency. In a preferred embodiment, six horizontal plates 14 are sufficient to enable tuning to the selected frequency. The two vertical conducting plates 16 are mounted perpendicular on a mounting flange 20. A coaxial feed 22 is joined to the base of antenna 10 at the center of the mounting flange 20. The center pin or feed probe 18 of the coaxial feed 22 protrudes from the mounting flange 20 to the lowest horizontal plate 14.

[0016] Referring to FIG. 3, there is illustrated an approximate electrical equivalent circuit of the antenna 10 as presented, wherein the feed-point is denoted by F. In the circuit, inductances L_{g1} , L_{g2} , L_p represent inductances of the vertical conducting plates 16 and the feed probe 18 respectively. Inductance L_f and capacitance C_f are associated with the feed connection 22. The series circuit comprising resistor R_o , capacitor C_o and inductance L_o represent the effects of the ohmic resistance of the horizontal plates 14, the capacitance between the plates 14, and the self and mutual inductance of the plates 14 respectively. The conductance G_r represents the conductance due to the radiating portion of the

antenna 10, located in the region of the aperture 24 at the top of the antenna 10.

[0017] With the coaxial feed probe 18 at the base of the antenna 10, an alternating electromagnetic field is established between the adjacent horizontal parallel plates 14 that permit the propagation of electromagnetic field to the aperture 24. The power flow in the horizontal parallel plates 14 energizes the aperture 24, setting up an electromagnetic field that is radiated outward and away from the antenna 10. The power of the electromagnetic field is proportional to the radiation conductance G_r , which depends on the physical dimensions of the aperture 24.

[0018] The effectiveness of antenna 10 is demonstrated in its performance when situated near a conducting surface. Referring to FIG. 4, there is illustrated the X-Y plane radiation pattern of the antenna 10 based on the orientation of the antenna in FIG. 1. When antenna 10 is situated on a conducting plane 26, as illustrated in FIG. 5, the pattern is hemispherical in shape as illustrated in FIGS. 6 and 7.

[0019] The advantage of the present invention is that this antenna design provides a compact antenna capable of operation near a metallic surface, and amenable to fabrication techniques such as molding or extrusion.

[0020] While it is apparent that the illustrative embodiments of the invention disclosed herein fulfill the objectives of the present invention, it is appreciated that numerous modifications and other embodiments may be devised by those skilled in the art. Additionally, feature(s) and/or element(s) from any embodiment may be used singly or in combination with other embodiment(s). Therefore, it will be understood that the appended claims are intended to cover all such modifications and embodiments, which would come within the spirit and scope of the present invention.

PARALLEL PLATE ANTENNA

ABSTRACT

The invention as disclosed is a parallel plate antenna having a number of stacked horizontal plates and two vertical plates. Alternating ones of the horizontal plates are electrically coupled to one vertical plate such that the horizontal plates coupled to one vertical plate are interleaved with the horizontal plates coupled to the other vertical plate. The assembled antenna is mounted on a planar mounting flange. The height/width of the antenna is approximately $1/30^{\text{th}}$ of a wavelength at the frequency of operation.

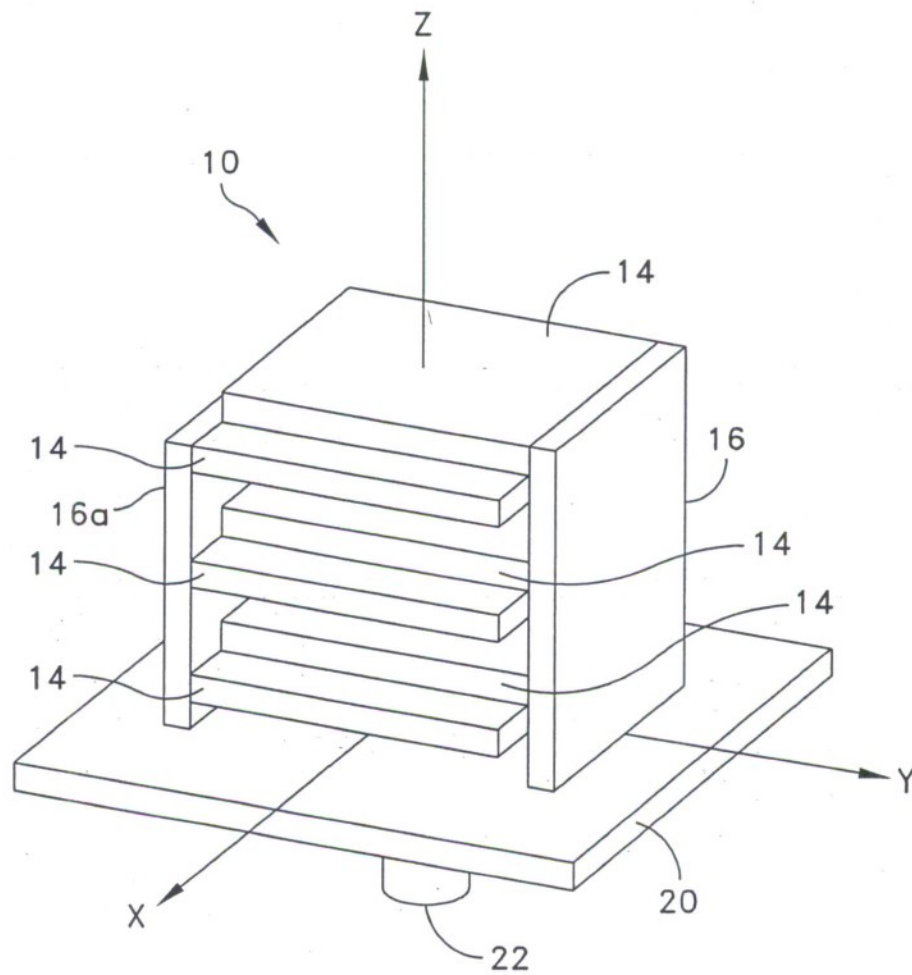

FIG. 1

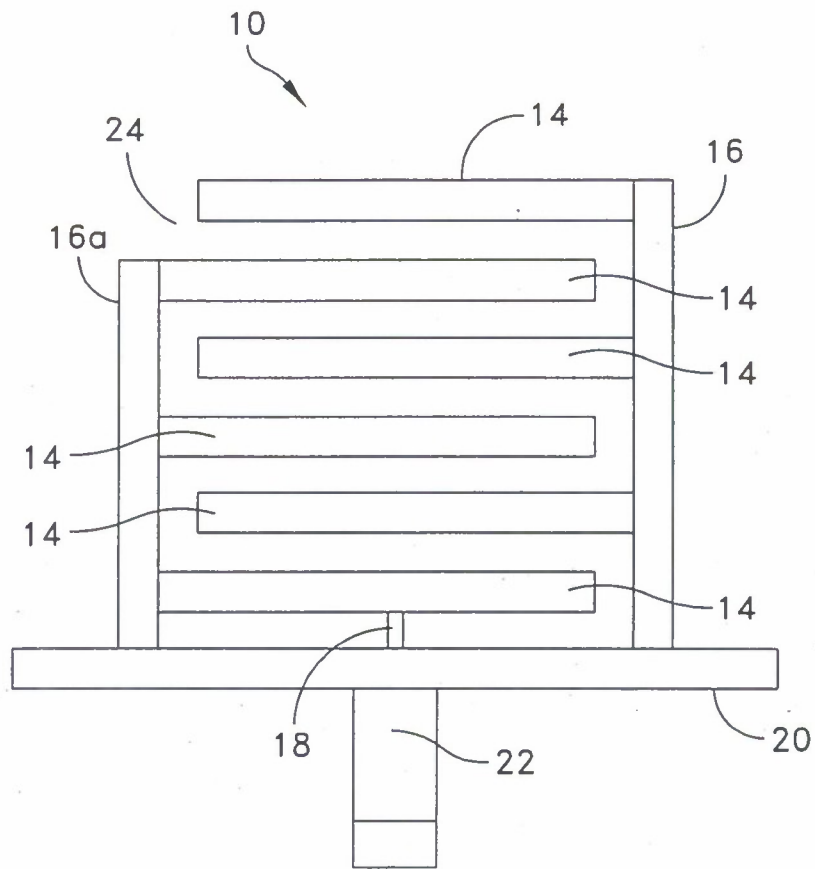

FIG. 2

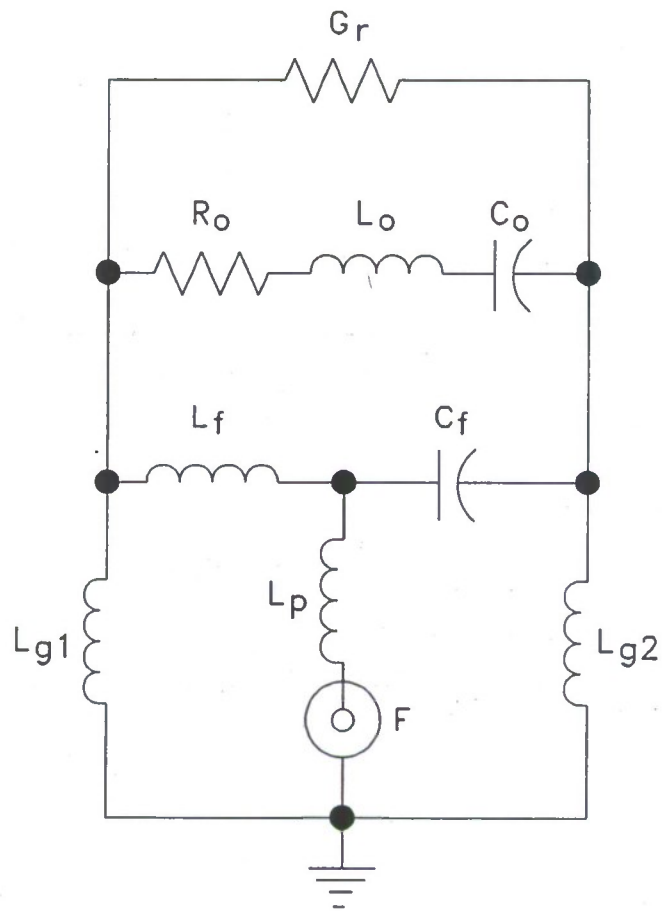

FIG. 3

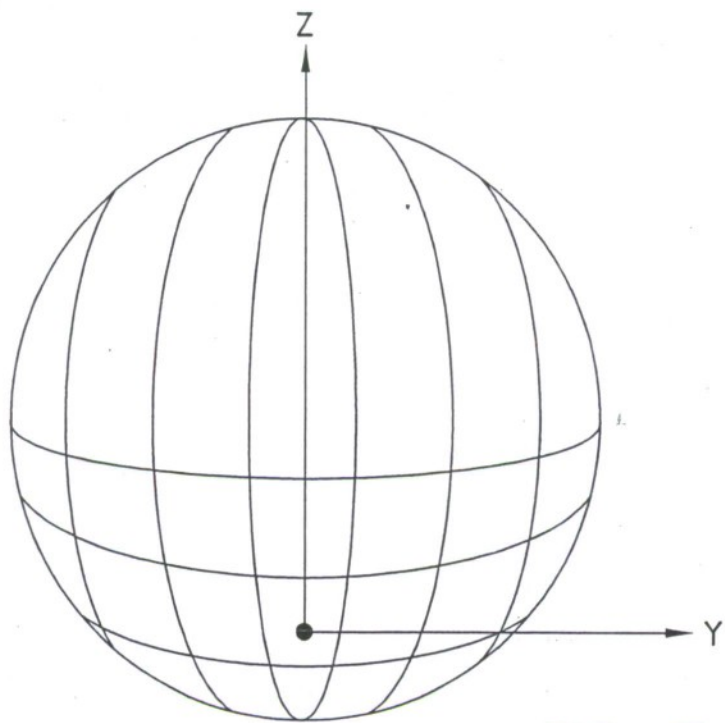

FIG. 7

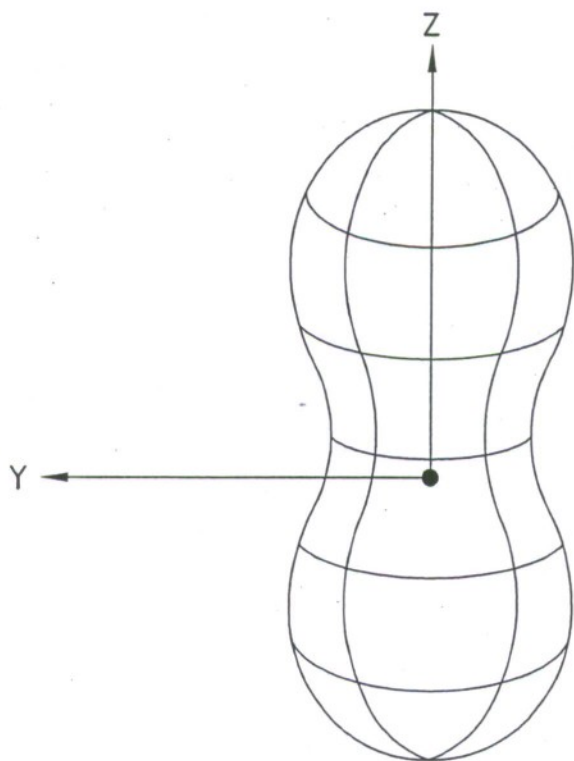

FIG. 4

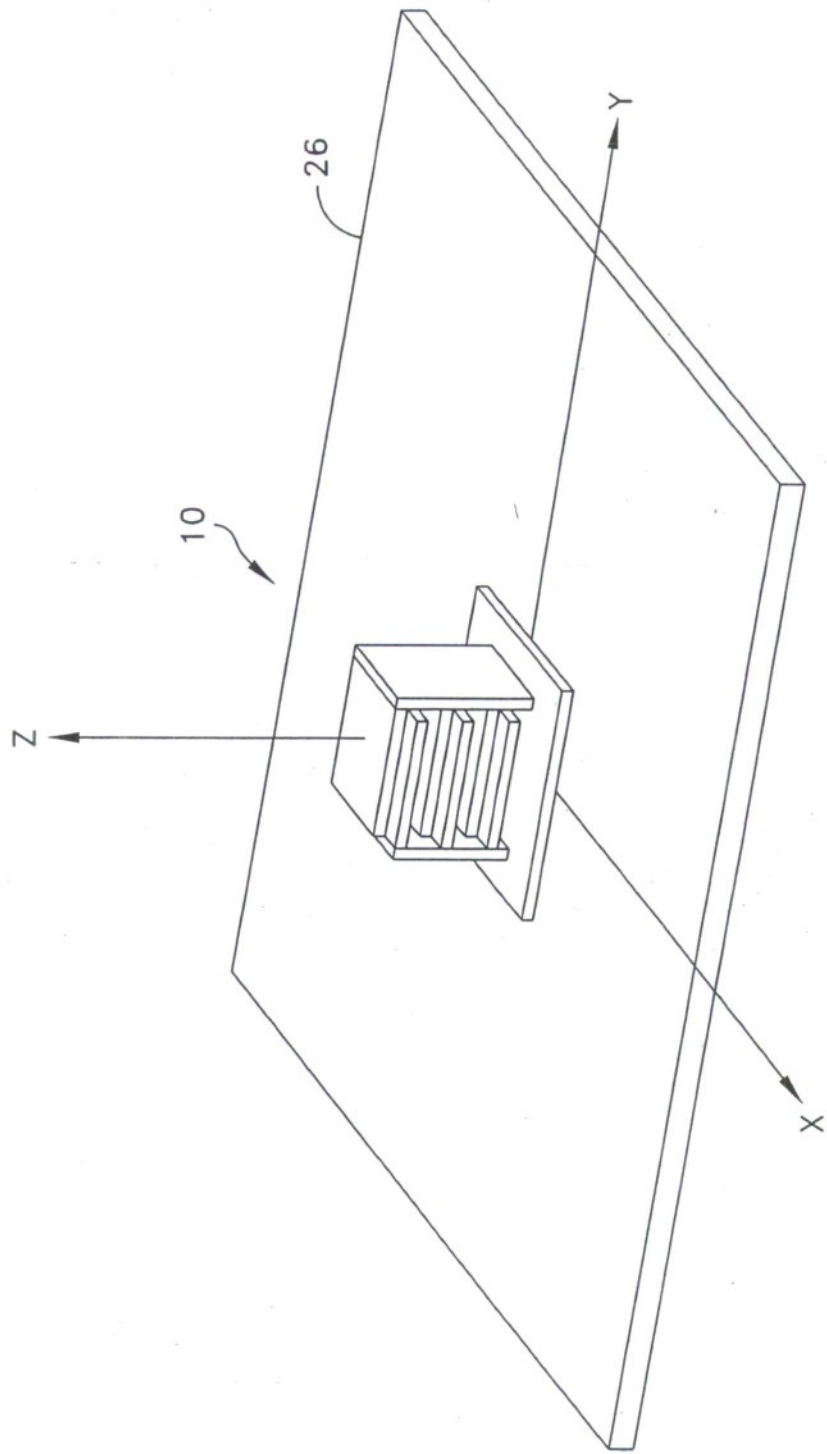

FIG. 5

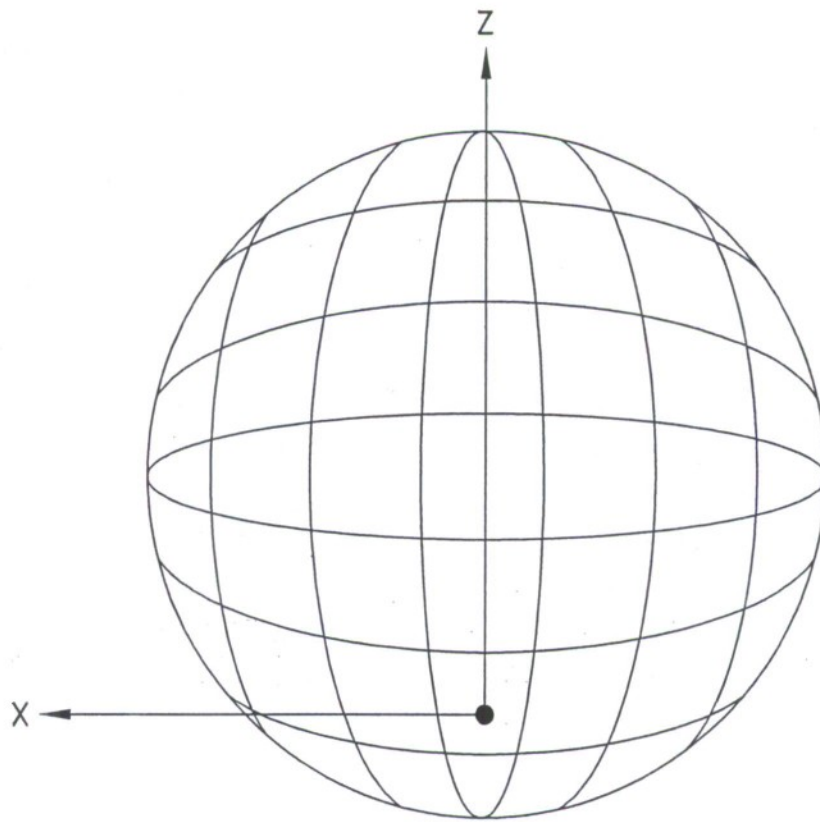

FIG. 6