



DEPARTMENT OF THE NAVY
NAVAL UNDERSEA WARFARE CENTER
DIVISION NEWPORT
OFFICE OF COUNSEL
PHONE: 401 832-3653
FAX: 401 832-4432
DSN: 432-3653



Navy Case No. 98627
Date: 10 October 2008

The below identified patent application is available for licensing. Requests for information should be addressed to:

TECHNOLOGY PARTNERSHIP ENTERPRISE OFFICE
NAVAL UNDERSEA WARFARE CENTER
1176 HOWELL ST.
CODE 07TP, BLDG. 990
NEWPORT, RI 02841

Serial Number 12/284,479
Filing Date 19 September 2008
Inventor Thomas R. Howarth

Address any questions concerning this matter to the Office of Technology Transfer at (401) 832-1511.

DISTRIBUTION STATEMENT
Approved for Public Release
Distribution is unlimited

20081027291

PIEZOELECTRIC GENERATOR AND METHOD

STATEMENT OF GOVERNMENT INTEREST

[0001] The invention described herein may be manufactured and used by or for the Government of the United States of America for governmental purposes without the payment of any royalties thereon or therefore.

CROSS REFERENCE TO OTHER PATENT APPLICATIONS

[0002] None.

BACKGROUND OF THE INVENTION

(1) Field of the Invention

[0003] The present invention relates generally to electric energy generation from mechanical sources and, more particularly, to a transducer module that is optimized to generate electrical energy from environmental, mechanical, and mechanical compression forces that otherwise could not be used.

(2) Description of the Prior Art

[0004] While piezoelectric materials have been successfully utilized in sensors and actuators, their use as practical power sources for generating a useful amount of electricity in portable generators has been limited. Users of piezoelectric devices are presently substantially limited to operating only very low power

devices, such as LEDs. This operation is typically limited to only a brief flash.

[0005] For practical use, the inventor believes that to power portable electrical devices, it would be necessary that electricity be generated using a large number of piezoelectric transducers. Preferably, such a system would be able to store power generated over a period of time. Thus, a practical system would require signal conditioners such as rectifiers and power storage, such as batteries. The need for a large number of piezoelectric transducers with many interconnections between components such as rectifiers and batteries increases the weight, reduces the robustness, and increases the complexity and difficulty of packaging such devices, especially for purposes such as being carried on a person, device, or object. Moreover, a practical system should be adaptable for capturing energy produced by different types of motions, with different amounts of force or translational movement. The prior art does not address the above problems.

[0006] The following U.S. Patents describe various prior art systems that may be related to the above and/or other transducer module systems.

[0007] U.S. Patent No. 5,955,790, issued September 21, 1999, to North, discloses a power transfer system for generating electrical energy from recurring wave and tidal movement within the ocean. The system comprises a pressure sensing device, such

as an array of pressure transducers, positioned at the ocean floor below water level and at a location of wave movement for (i) registering changes in height of water above the pressure sensing device and (ii) providing a power output corresponding to changes in force associated with the changes in the height of water. A transfer medium is coupled at one end to the pressure sensing device and extends underground to a second end at a shore location adjacent the location of wave movement for transmitting the power output of the pressure sensing device to the shore location. A bank of storage batteries is coupled to the transfer medium at the shore location for receiving the power output from the transfer medium and for storing the power output as a useful form of energy.

[0008] U.S. Patent No. 6,438,242, issued August 20, 2002, to Howarth, discloses an electro-acoustic transducer in which a plurality of cymbal-type electro-acoustic actuators are disposed in mechanical and electrical parallel between a pair of stiff plates. The resultant transducer resonates at a lower frequency than the cymbals, with a greater generated force. An example of a plurality of cymbal type transducers is shown in FIG. 1.

[0009] U.S. Patent No. 6,737,789, issued May 18, 2004, to Radziemski, et al., discloses a force activated electrical power generator using piezoelectric elements of preferred lead-magnesium-niobate lead titanate (PMN-PT). The circuitry is in preferred versions completely passive generating all power

needed. Some circuitry limits voltage across the elements and provides a return charge channel to prevent depolarization. Transformers can be used to increase the output voltage and efficiency. Rectifiers are shown to rectify the output to a single polarity. Filtering, regulation and other conditioning components are also shown. The output from the generator and circuitry can store the electrical charge, such as in a capacitor and/or battery.

[0010] U.S. Patent No. 7,157,802, issued January 2, 2007, to Bodkin, discloses an electrical power source that derives input power from a compressed gas which is fed into a transducer, generating electrical power. The compressed gas may be delivered to the unit by several means including manual pumps, thermal, chemical, or ammunition based sources, or connection to pressurized canisters. Optional power converting and feedback circuits and pneumatic valves serve to convert the raw output power into useful AC and DC output voltages, and to match the rate of power delivery to the applied electrical load.

[0011] U.S. Patent No. 7,239,066, issued July 3, 2007, to Ott, et al., discloses a piezoelectric power generator that comprises a plurality of piezoelectric devices, an actuator positioned to impart an excitation to the plurality of piezoelectric devices in a predefined sequence, and an electrical conduction system connected to the plurality of piezoelectric devices for conducting an electrical charge created by the

excitation. Preferably, the plurality of piezoelectric devices are arranged in a predetermined relationship relative to the actuator whereby only one of the plurality of piezoelectric devices is actuated at a time. For example, the plurality of piezoelectric devices can be arranged in an angular pattern (such as a circular pattern) relative to the actuator. Preferably, a rotational speed of the actuator (24) permits an excitation response for a given piezoelectric device to essentially fully decay before the given piezoelectric device is again excited.

[0012] U.S. Patent No. 7,260,984, issued August 28, 2007, to Roundy, et al., discloses a method of powering one or more electronic devices in a tire monitoring system using a tire pressure based energy scavenger. With this method, a tire is rotated on a surface to generate pressure changes within the tire. These pressure changes are then converted into electrical energy with a transducer and the energy is stored. The electrical energy or stored electrical energy can then be used to power one or more electronic devices in a tire monitoring system, such as a tire pressure sensor, temperature sensor, acceleration profile sensor, and/or a tire wear monitor. A tire monitoring system with a tire pressure based energy scavenger is also provided.

[0013] International Application No. PCT/US05/35683, published April 13, 2006, to Raisanen, discloses methods for analyzing characteristics of fluids in the context of an acoustic

ejection system. Such a system has a controller, an acoustic radiation generator, and a coupling medium coupling the radiation to a reservoir holding fluid. The methods can use acoustic radiation to both perturb a surface of the fluid in the reservoir and analyze the effect of the perturbation. The methods may use information about prior fluids. The methods of the invention can determine physical characteristics such as speed of sound and viscosity. The methods also include ways to determine a level of acoustic energy suitable to eject a droplet.

[0014] The above cited prior art does not disclose a module system that is optimized to generate electrical energy from mechanical and environmental sources, specifically compressive forces, where an array of cymbal transducers is positioned between two rigid plates that are electrically conductive and are coupled to any of the cymbal transducers that are adjacent thereto. Signal conditioning electronics can be coupled to the electrically conductive portions of the plates, and a battery can be connected to the signal conditioning electronics.

[0015] As discussed above, solutions to the above described and/or related problems have been long sought without success. Consequently, those skilled in the art will appreciate the present invention that addresses the above and other problems.

SUMMARY OF THE INVENTION

[0016] It is a general purpose of the present invention to provide an improved method and apparatus for generation of electrical energy from environmental, mechanical, and mechanical compression forces that otherwise could not be used.

[0017] An object of the present invention is to provide an improved method and apparatus for piezoelectric transducer arrays adapted for harvesting energy from periodic compressive forces.

[0018] Accordingly, the present invention provides a method and apparatus for producing energy from movement of a user. Steps of a method in accord with one possible embodiment of the invention may comprise providing at least one pair of plates and securing an array of cymbal transducers between the pair of plates.

[0019] In one possible embodiment, the method may comprise integrating power storage such as a battery or capacitor into the plates. Signal conditioning circuitry may also be integrated into the plates. The plates may be provided with a flexible portion, wherein the power storage and/or signal conditioning circuitry may be mounted.

[0020] The method may comprise mounting stops throughout the array of cymbal transducers to prevent over compression of the array of cymbal transducers.

[0021] In one embodiment, the method may comprise mounting the plurality of cymbal transducers in staggered orientation between the pair of plates.

[0022] The method may comprise connecting wires to the battery for powering an outside device using the harvested energy.

[0023] In one presently preferred embodiment, the apparatus may comprise at least one pair of plates and an array of cymbal transducers adapted for harvesting energy from periodic compressive forces secured between the plates. A series of stop members can be mounted between the plates to limit movement. The pair of plates and array of cymbal transducers therein may be mountable with respect to the user to move in response to the movement of the user to thereby produce the energy. The apparatus may comprise the battery and/or signal conditioning circuitry integrated into at least one pair of plates.

[0024] In one possible embodiment, the method may comprise integrating a power storage and/or signal conditioning circuitry into the plates.

[0025] The apparatus may comprise a flexible portion of at least one of the plates wherein power storage and/or signal conditioning circuitry may be mounted.

[0026] The apparatus may comprise wires or other power conductors connected to the battery for powering an outside device using the harvested energy.

BRIEF DESCRIPTION OF THE DRAWINGS

[0027] A more complete understanding of the invention and many of the attendant advantages thereto will be readily appreciated as the same becomes better understood by reference to the following detailed description when considered in conjunction with the accompanying drawings, wherein like reference numerals refer to like parts and wherein:

[0028] FIG. 1 is a cross-sectional view showing a single enlarged cymbal transducer in accord with one possible embodiment of the present invention.

[0029] FIG. 2 is a cross-sectional view showing an array of cymbal transducers, a pair of plates, a battery, and signal conditioning circuitry, in accord with one possible embodiment of the present invention.

[0030] FIG. 3 is a cross-sectional view of an array of cymbal transducers having the battery and signal conditioning circuitry integrated into at least one of the plates, in accord with one possible embodiment of the present invention.

[0031] FIG. 4 is a cross-sectional view of an array of cymbal transducers having stops mounted between the plates, in accord with one possible embodiment of the present invention.

[0032] FIG. 5 is a cross-sectional view of an arrangement of cymbal transducers arranged in columns, in accord with one possible embodiment of the present invention.

[0033] FIG. 6 is a top view, showing disc shaped cymbal transducers in a linear serial arrangement, in accord with one possible embodiment of the present invention.

[0034] FIG. 7 is a top view, showing disc shaped cymbal transducers in a staggered serial arrangement, in accord with one possible embodiment of the present invention.

DESCRIPTION OF THE INVENTION

[0035] The present invention may be utilized for harvesting electrical energy from environmental, mechanical, and mechanical compression forces that otherwise could not be used.

[0036] FIG. 1 illustrates an enlarged view of a type of transducer that is referred to herein as cymbal transducer 10, which may be utilized in accord with the present invention. Transducer 10 has a disk 12 of piezoelectric material. Piezoelectric material can be a single crystal or multi-crystal PZT or the like formed in a disk shape. Cymbals 14A and 14B are joined to top and bottom surfaces 16A and 16B of disk 12. Cymbals 14A and 14B are made from a rigid material that supports elastic deformation. This material can be a metal, a rigid plastic, and/or other suitable material.

[0037] Electrical contacts 18 are joined to each surface of disk 12. If made of metal, cymbals 14A and 14B can provide this electrical contact. However, cymbals 14A and 14B can be used to provide mechanical to support electrical contacts, such as wires

and the like, regardless of the material of which cymbals 14A and 14B are comprised. There is a gas-filled gap 20 between each cymbal 14A and 14B and the surface of disk 12.

[0038] FIG. 2 illustrates components of a working piezoelectric generator in accord with the present invention. Array 30 of cymbal transducers 10 positioned between two rigid plates 32 whereby electricity may be produced simultaneously from a large number of cymbal transducers 10. Plates 32 can be conductive or can have conductive members formed thereon to capture electrical energy generated by compression of cymbal transducers 10. Each plate 32 is joined to a conductive element 34. Conductive elements 34, such as wires, power busses, and the like, are joined to signal conditioning circuitry 36. Typical signal conditioning circuitry 36 can include a rectifier, bridge rectifier, or the like, for changing the provided alternating electrical current to conditioned direct current at a desired voltage and current. If desired, more complex signal conditioning circuitry may also be used such as transformers, voltage doublers or triplers. Signal conditioning circuitry is joined to a power storage device such as battery 38 to provide the conditioned direct current for charging. Battery 38 can then be used to provide a steady output to power outside devices. Other power devices such as capacitors or the like may also be charged.

[0039] FIG. 3 illustrates another possible embodiment wherein signal conditioning circuitry 36 and battery 38 are embodied in a rigid plate 32'. Circuitry 36 may be flex circuitry or some other circuitry joined to or formed within a rigid, but thin substrate. Flex circuitry may refer to any known type of available flex circuitry such as, for example, flat flexible circuits, rigid flexible circuits, polymer thick film flex circuits, flex membranes, and the like. Battery 38 can be any kind of rigid thin battery known in the art. Battery 38 could also be a supercapacitor or some other sort of energy storage device as driven by the demands of the application. This embodiment is more compact than that shown in FIG. 2. Size may be a critical factor in many of the uses of this device. Connections 34 may be made internally of the array but are shown externally for convenience.

[0040] FIG. 4 illustrates another embodiment of the invention. This embodiment includes stops 40 joined to plates 32 and 32'. Stops 40 are positioned among the cymbal transducers 10 to prevent over-compression of the cymbals, thereby preventing damage and extending the life of array 30. Height of stops 40 should be sufficient to preserve cymbal deformation within the elastic range of the cymbal material. This embodiment may be useful where forces produced by the user, such as the feet during running or walking, may sometimes be quite large.

[0041] FIG. 5 illustrates an embodiment of the invention having a serial arrangement of cymbal transducers 10. In this embodiment, transducers 10 are arranged in a plurality of columns 42. Each of the columns comprises a plurality of cymbal transducers 10 stacked on top of each other. Compression of plates 32 compresses all transducers 10 in each column and may compress all columns 42. While the plates contact only the uppermost and lowermost transducers 10, the force acting on those transducers is also applied to the middle transducers 10 in each stack. This embodiment allows for a longer power or force stroke to capture energy produced thereby.

[0042] Wiring to interconnect the transducers may connect the transducers in parallel if greater current output is desired or in parallel to increase the voltage output. In one possible embodiment, outputs of cymbal transducers 10 for each column 42 may be connected in series and the resulting outputs of each column 42 may be connected in parallel. For example, if metal material is utilized for cymbals 14A and 14B as shown in FIG. 1, then this metal material may also be utilized to complete the circuit to provide a series connection between outputs of cymbal transducers 10 in each column. If plates 32 are metal, then the outputs of each column 42 are then in parallel.

[0043] Other wiring arrangements might also be utilized. To produce a relatively higher voltage, cymbal transducers 10 for each column may be connected in series as discussed above, and

then the outputs of each column 42 may be connected in series with interconnecting wires between plates 32. In this manner, the voltage produced may be equal to the voltage output of each cymbal transducer multiplied by the number of transducers in an array.

[0044] FIG. 6 illustrates an embodiment of the invention showing a two or three-dimensional array of cymbal transducers 10. In this embodiment, transducers 10 are arranged so that all rows of transducers are centered on parallel lines in both the x and y directions as seen from the top. Transducers 10 may comprise a depth or columns of transducers as shown from the side in FIG. 5 to capture a long stroke. Alternatively, only one or a few transducers 10 may be utilized for a short stroke of applied force or power.

[0045] FIG. 7 illustrates an embodiment of the invention showing a staggered configuration for a two or three-dimensional array of cymbal transducers 10. In this embodiment, transducers 10 may be spaced so that adjacent rows of transducers are offset from each other. In FIG. 7, the signal conditioning circuitry 36 and battery 38 are shown to be separately integrated into the apparatus. The dark section of FIG. 7 in the top right hand corner may represent the combination of the circuitry 36 and/or battery 38 integrated into the apparatus. However, circuitry 36 and/or battery 38 may be integrated into various positions.

[0046] Further embodiments of this invention are envisioned that involve parallel and serial arrangements of cymbal transducers that could be tailored to the specific use. Serial arrangements can provide power when larger forces and translations are available. Larger transducers are more suited to low frequency usage. Cymbal transducer size can vary with the use.

[0047] It is suggested that this invention can be used in remote locations where electrical power is difficult to provide to a device. Two suggested applications are for capturing energy generated during walking and as a manual squeeze power source.

[0048] In summary, the present invention provides a method and apparatus for producing and harvesting energy from movement of a user that otherwise could not be used. In the preferred embodiment, steps of the method may comprise providing at least one pair of plates. In one possible embodiment, the method can comprise integrating a battery and signal conditioning circuitry into at least one of the pair of plates and/or securing an array of cymbal transducers between the pair of plates. The method may also comprise providing that the array of cymbal transducers is adapted for harvesting energy from periodic compressive forces. It is provided that the pair of plates and array of cymbal transducers therein are mountable with respect to the user to move in response to the movement of the user to thereby produce the energy. The array is optimized to generate electrical energy

from environmental, mechanical, and especially mechanical compression forces, where a system of an array of cymbal transducers is positioned between two rigid plates that are electrically conductive and are coupled to any of the cymbal transducers that are adjacent thereto. Signal conditioning electronics are coupled to the electrically conductive portions of the plates, and a battery can be connected to the signal conditioning electronics.

[0049] The present invention may be mounted in the heel of a boot, provided as a hand carried device, or implemented as a mat in commonly used devices such as chairs, sleeping bags, or the like. The present invention may be adapted to simultaneously provide cushioning for the user and to generate electricity. The present invention may be adapted to be operated by the legs while standing or laying or by the user's arms. The two-dimension and three-dimensional structures of the array are readily adaptable to many shapes and may be sewn into position or mounted into position, such as the heel of boots.

[0050] Many additional changes in the details, components, steps, and organization of the system, herein described and illustrated to explain the nature of the invention, may be made by those skilled in the art within the principle and scope of the invention. It is therefore understood that within the scope of the appended claims, the invention may be practiced otherwise than as specifically described.

PIEZOELECTRIC GENERATOR AND METHOD

ABSTRACT OF THE DISCLOSURE

An apparatus and method is provided to produce energy from movement of a user. At least one pair of plates is utilized to secure an array of cymbal transducers therebetween. The array of cymbal transducers is electrically interconnected with signal conditioning circuitry and power storage member. Electrical interconnections may comprise parallel and/or series connections between ones or groups of the cymbal transducers.

FIG. 1
PRIOR ART

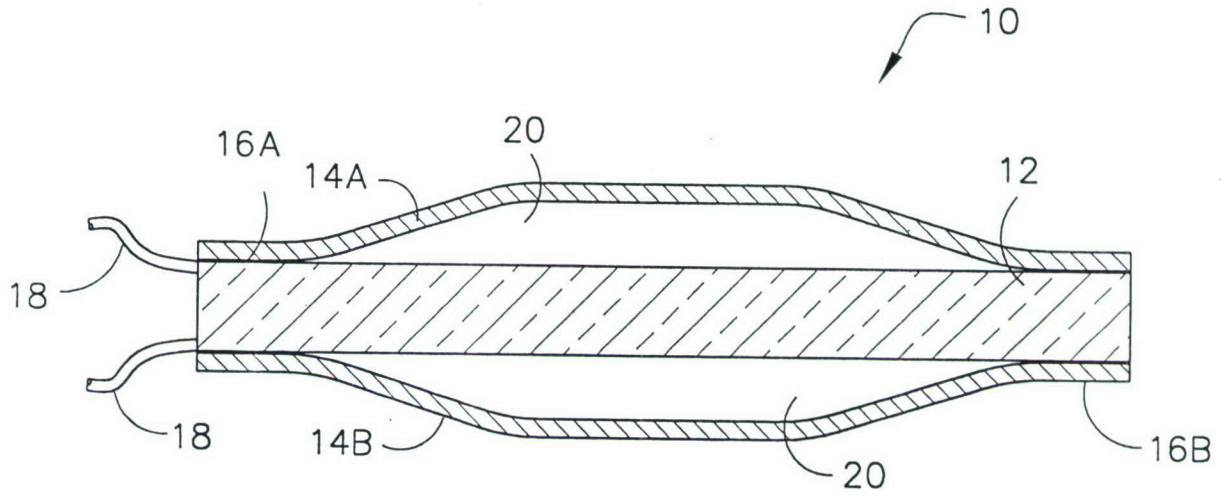

FIG. 2

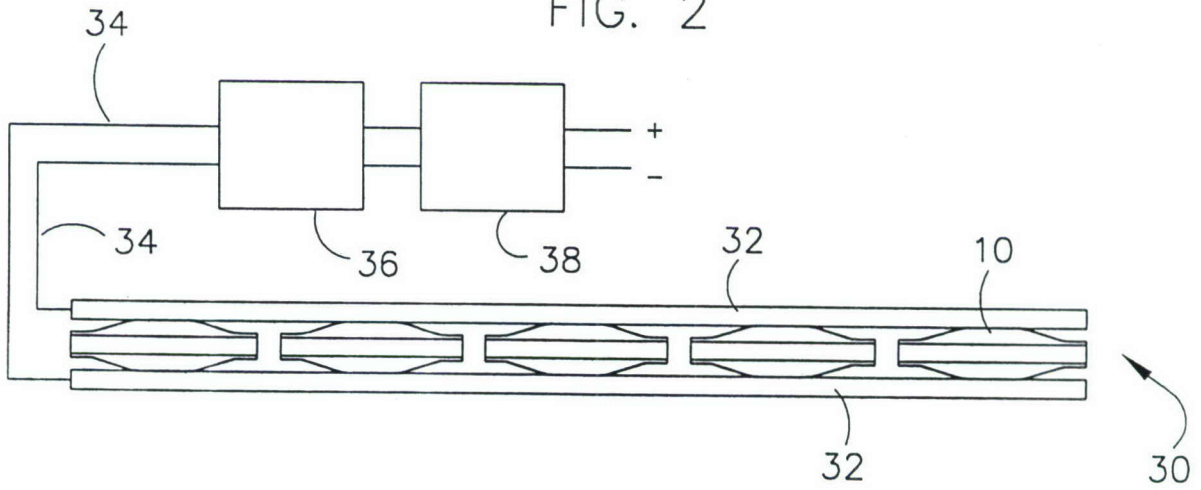

FIG. 3

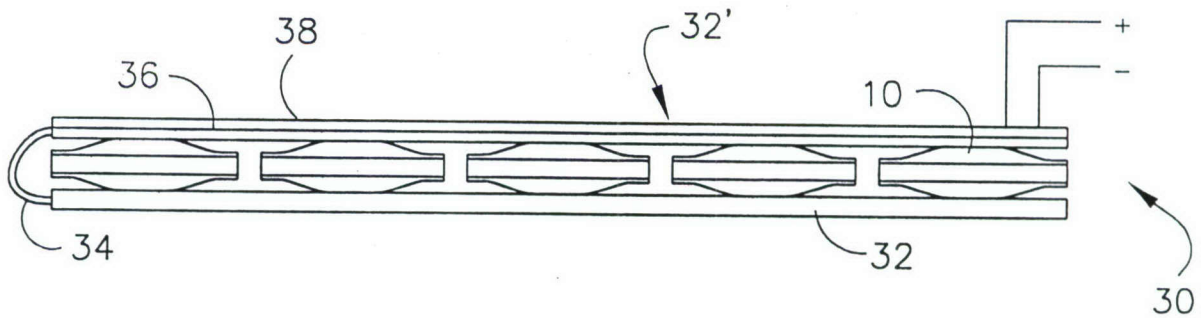

FIG. 4

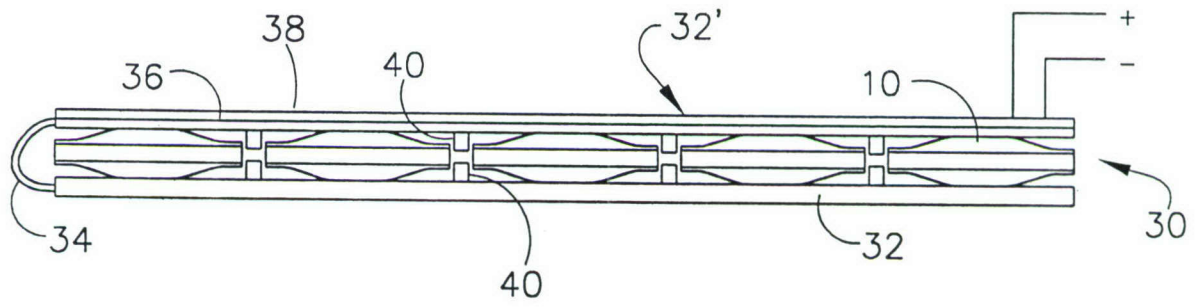

FIG. 5

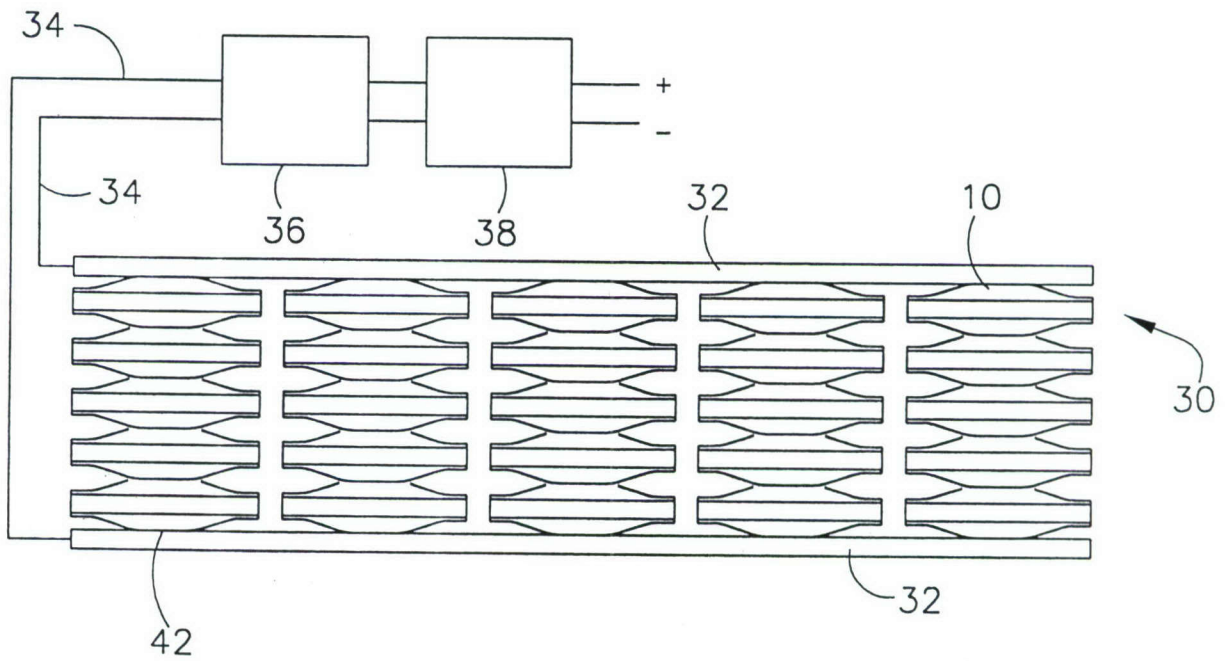

FIG. 6

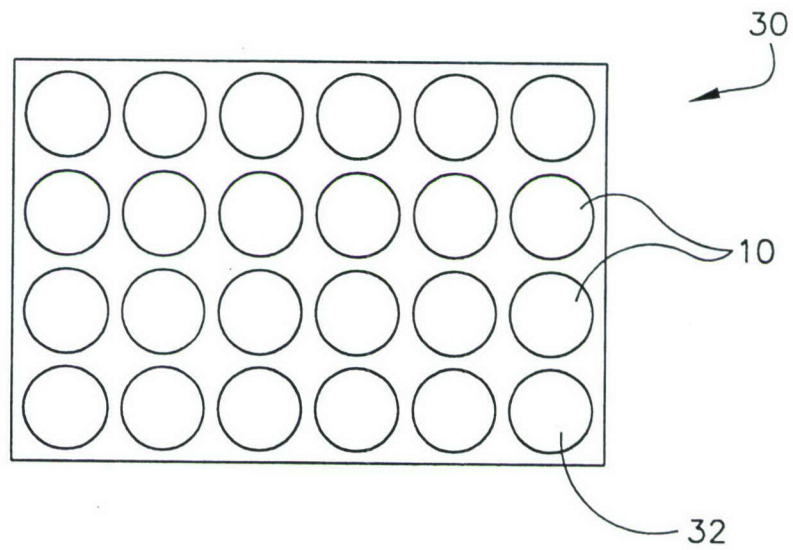

FIG. 7

