



US006726052B1

(12) **United States Patent**  
**Miller**

(10) **Patent No.:** **US 6,726,052 B1**

(45) **Date of Patent:** **Apr. 27, 2004**

(54) **COLLAPSIBLE FLUID TRANSPORT TANK**

4,875,596 A \* 10/1989 Lohse ..... 220/1.6

(75) Inventor: **Leo P. Miller**, Roseville, MI (US)

6,129,236 A \* 10/2000 Osokin et al. .... 220/723

6,401,966 B2 \* 6/2002 Tsai ..... 220/723

(73) Assignee: **The United States of America as represented by the Secretary of the Army**, Washington, DC (US)

\* cited by examiner

(\*) Notice: Subject to any disclaimer, the term of this patent is extended or adjusted under 35 U.S.C. 154(b) by 0 days.

*Primary Examiner*—Joseph Man-Fu Moy

(74) *Attorney, Agent, or Firm*—David L. Kuhn; Gail S. Soderling; Clifford C. Carter

(21) Appl. No.: **10/392,483**

(57) **ABSTRACT**

(22) Filed: **Mar. 19, 2003**

(51) **Int. Cl.**<sup>7</sup> ..... **B68D 88/12**

A flexible container for the transportation of fluids having means to keep the container in a sufficiently rigid shape that it can be moved and handled using conventional techniques until empty at which time the container can be collapsed for ease of shipment and storage.

(52) **U.S. Cl.** ..... **220/666; 220/723**

(58) **Field of Search** ..... **220/666, 723, 220/720**

(56) **References Cited**

U.S. PATENT DOCUMENTS

**2 Claims, 1 Drawing Sheet**

3,802,464 A \* 4/1974 Frank et al. .... 138/30

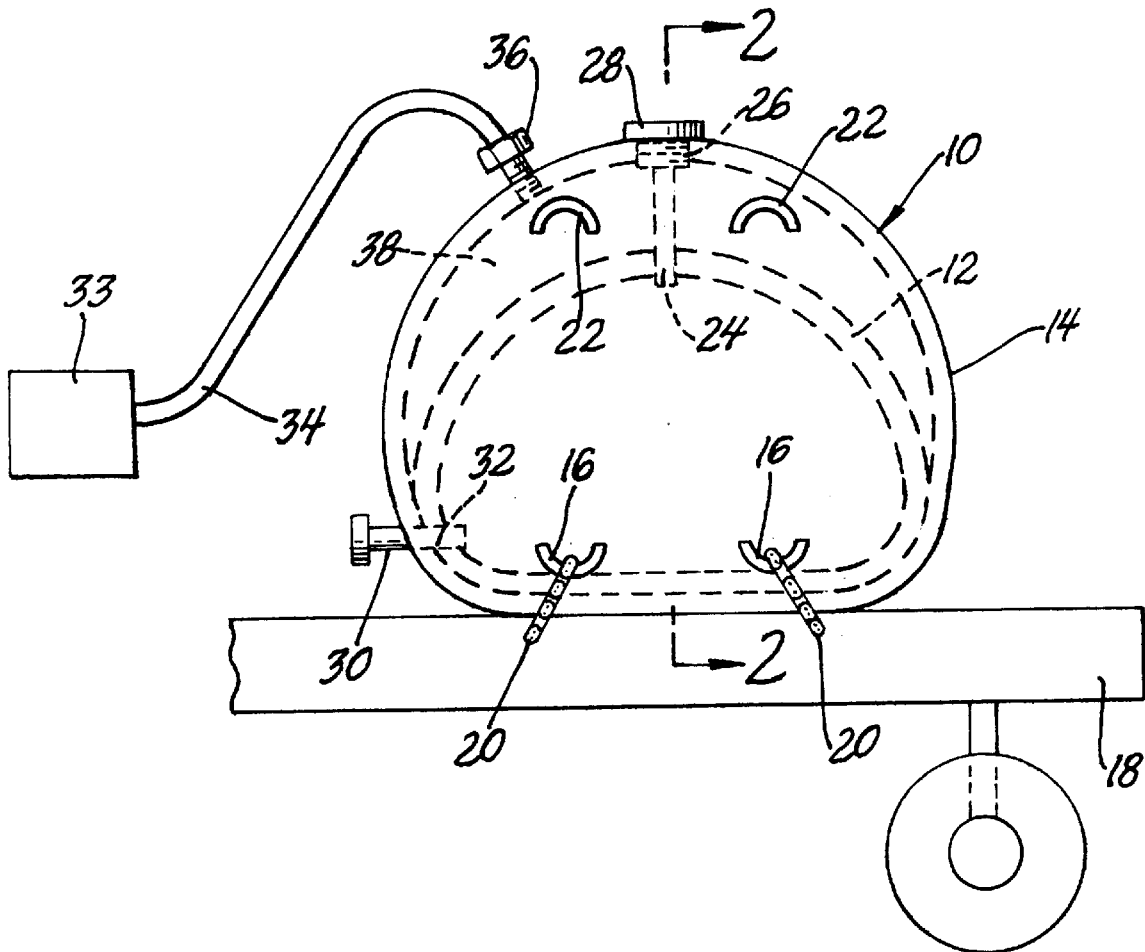

## Report Documentation Page

*Form Approved*  
*OMB No. 0704-0188*

Public reporting burden for the collection of information is estimated to average 1 hour per response, including the time for reviewing instructions, searching existing data sources, gathering and maintaining the data needed, and completing and reviewing the collection of information. Send comments regarding this burden estimate or any other aspect of this collection of information, including suggestions for reducing this burden, to Washington Headquarters Services, Directorate for Information Operations and Reports, 1215 Jefferson Davis Highway, Suite 1204, Arlington VA 22202-4302. Respondents should be aware that notwithstanding any other provision of law, no person shall be subject to a penalty for failing to comply with a collection of information if it does not display a currently valid OMB control number.

1. REPORT DATE <b>27 APR 2004</b>	2. REPORT TYPE <b>N/A</b>	3. DATES COVERED <b>-</b>			
4. TITLE AND SUBTITLE <b>Collapsible Fluid Transport Tank</b>		5a. CONTRACT NUMBER			
		5b. GRANT NUMBER			
		5c. PROGRAM ELEMENT NUMBER			
6. AUTHOR(S) <b>Leo P. Miller</b>		5d. PROJECT NUMBER			
		5e. TASK NUMBER			
		5f. WORK UNIT NUMBER			
7. PERFORMING ORGANIZATION NAME(S) AND ADDRESS(ES) <b>US Army RDECOM-TARDEC 6501 E 11 Mile Rd Warren, MI 48397-5000</b>		8. PERFORMING ORGANIZATION REPORT NUMBER <b>18727</b>			
9. SPONSORING/MONITORING AGENCY NAME(S) AND ADDRESS(ES)		10. SPONSOR/MONITOR'S ACRONYM(S) <b>TACOM/TARDEC</b>			
		11. SPONSOR/MONITOR'S REPORT NUMBER(S) <b>18727</b>			
12. DISTRIBUTION/AVAILABILITY STATEMENT <b>Approved for public release, distribution unlimited</b>					
13. SUPPLEMENTARY NOTES <b>United States Patent No.: 6,726,052 B1</b>					
14. ABSTRACT					
15. SUBJECT TERMS					
16. SECURITY CLASSIFICATION OF:			17. LIMITATION OF ABSTRACT <b>SAR</b>	18. NUMBER OF PAGES <b>4</b>	19a. NAME OF RESPONSIBLE PERSON
a. REPORT <b>unclassified</b>	b. ABSTRACT <b>unclassified</b>	c. THIS PAGE <b>unclassified</b>			

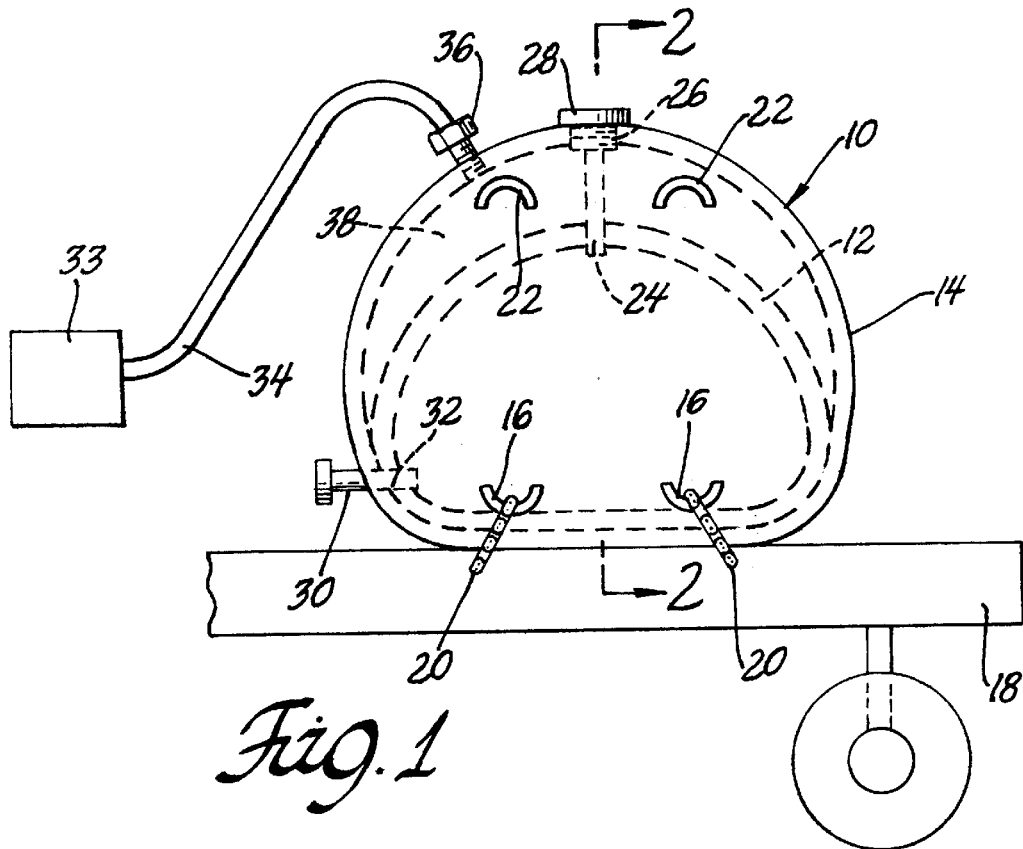

Fig. 1

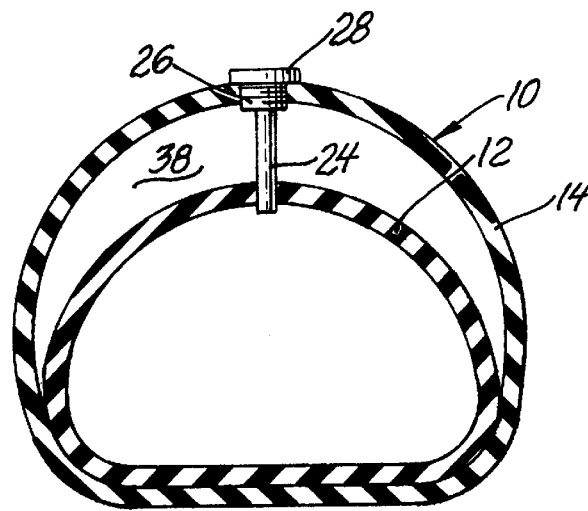

Fig. 2

**COLLAPSIBLE FLUID TRANSPORT TANK****GOVERNMENT INTEREST**

The invention described here may be made, used and licensed by The United States Government for governmental purposes without paying me any royalty.

**BACKGROUND OF THE INVENTION**

In one aspect this invention relates to collapsible containers. In yet a further aspect this invention relates to fuel transport means.

Modern military operations require the use of substantial amounts of fuel. Even though the fuel capacity of most military vehicles is substantial, the vehicles high rate of fuel consumption limits the distance they can travel without refueling. In order to extend the military range it is necessary to carry additional fuel to the vehicles.

The military has adopted the use of various sized collapsible containers such as flexible bladders which can be collapsed in order to return them to a refueling port once they've been emptied. However, under current operating conditions use of bladders is restricted to either fully loaded or fully collapsed because the present bladder structure loses its form and stability whenever the bladder is partially emptied. Thus, a bladder which has had any quantity of fuel removed cannot be moved, transported or stored. Because of this problem, the convenient and useful collapsible vessels have been relegated to a secondary role in favor of various rigid walled vessels. The non collapsible storage containers require substantially more space for shipment and storage when empty and increase the logistics requirements when compared to collapsible bladders or containers.

It would be desirable to have a collapsible fluid handling system which can be transported, stored, and moved in a partially filled condition. Such vessels could increase the mission effectiveness by allowing use of standard equipment handling procedures of the type normally provided for the use of a rigid type containers. This would significantly reduce liquid transport cost and minimize the empty weight of the containers that must be handled.

**SUMMARY OF THE INVENTION**

The present invention provides a fluid transport container that solves the problems of the prior art structures to form a collapsible fluid transport mechanism. The structure of this invention has a flexible, inner containment bladder suitable for holding the fluid to be transported. Associated with this containment bladder will be means for filling and withdrawing the fluid in the containment bladder. An outer transport bladder surrounds and encloses the inner containment bladder. There are means associated with the transport bladder to insert a pressurized gas, such as air, within any space between the inner surface of the transport bladder and the outer surface of the containment bladder. The pressurized gas is maintained at a pressure sufficient to keep the transport bladder's shape and rigidity at a level that allows movement and transportation using conventional transportation techniques. The transport bladder has handling means attached to its outer surface which can be used for attaching cargo hold downs to hold the container in position or can be used to lift and move the container.

A major advantage of this system is the ability to ship the empty containers in a collapsed condition. When collapsed, the containers will consume less volume making for a decreased logistics burden. When a collapsed container

reaches a fuel transportation point it can be filled with the fluid to be transported and then placed on a vehicle to be transported to the final destination. The gas pressure maintenance feature will replace the volume of fluid removed from the containment bladder with the required volume of gas at a pressure that keeps the container transportable until the containment bladder is substantially completely emptied at which time the whole container can be collapsed for shipment to its desired location.

The advantages of the inventive transport container will allow it to accompany combat vehicles extending their range well beyond that of their on board fuel supplies. As fuel is consumed the present container will become lighter and consume less energy to transport when compared to tankers where the container has a substantial unloaded weight. This further increases the efficiency and range. Once the transport container is empty it will have only modest weight compared to other rigid containers so it can be cheaply returned for refilling.

**BRIEF DESCRIPTION OF THE DRAWINGS**

In the accompanying drawing:

FIG. 1 is a side view of one embodiment of a container according to this invention on a truck; and

FIG. 2 is a sectional view of the structure of FIG. 1 taken along the line 2—2.

**DETAILED DESCRIPTION**

Referring to the accompanying drawing wherein like numerals refer to like parts, The fluid transport container according to this invention is designated generally **10**. In the interior of transport container **10** is a flexible, inner containment bladder **12** suitable for holding a fluid to be transported. The inner containment bladder **12** can be formed of well known materials one example being neoprene synthetic rubber which can hold most types of fluids carried by the military. The inner, containment bladder **12** can also be made from a fluid tight, coated fabric. An outer transport bladder **14** surrounds and encloses the inner containment bladder **12**. The outer transport bladder **14** provides additional support for the transport container **10** when loaded and will generally be formed of gas and liquid impermeable material suitable for the fluid being transported. Like the inner containment bladder **12**, the transport bladder **14** can be made of fluid impermeable coated fabric or a synthetic rubber such as neoprene. The transport bladder **14** may also be formed as a multi-layer flexible laminated structure with a wear resistant outermost surface and a gas impermeable inner surface. A laminated transport bladder **14** would allow the vessel to have a strong wear resistant fabric on the outer surface to protect the bladder from puncture and abrasion while the inner lamella can be made from a material for the gas containment aspect of protection. The transport bladder **14** will have handling devices **16** attached to its outer surface. As shown in FIG. 1 there are two devices located on the lower portion of the transportation bladder **14** that are connected to a flat bed **18** of a truck by means of chains **20**. The chains **20** or other well known hold down devices are used during transport to hold the transport container **10** firmly on the flat bed **18**. Upper lifting devices **22** can be used with slings, hooks or other crane mounted lifting means to move the transport container **10** onto and off of the flat bed **18**. The upper lifting devices **22** can also be used to load and unload transport containers **10** from ship's holds and the like.

The containment bladder **12** has a filler tube **24** with an inlet **26** mounted in the transportation bladder **14** and closed

by means of a cap **28**. The filler tube **24** is sized and flexible so that as the fluid level in the containment bladder **12** changes causing the containment bladder to expand and contract the filler tube remains connected. The containment bladder **12** has fluid outlet **30** mounted in the transportation bladder **14** with a flexible connector tube **32** providing fluid connection between the outlet and the containment bladder **12**. The outlet **30** shown is of a simple tube and nozzle design other fluid extraction means be known in the art and easily incorporated, one example being a siphon structure. Pumping structures are also contemplated as being within the scope of this invention.

When the containment bladder **12** is completely filled, the pressure of the fluid, particularly if it is a liquid, will provide a degree of rigidity to the over all structure. However as fluid is withdrawn from the containment bladder **12**, this rigidity is compromised since both the transportation bladder **14** and containment bladder **12** are collapsible. The transportation container **10** of this invention has means associated with the transportation bladder **14** to supply pressurized gas to the interior of the transportation bladder **14** to maintain a predetermined internal pressure in the space between the inner surface of the transport bladder and the outer surface of the containment bladder **12**. The pressure supplied will be at a level sufficient to maintain the transportation bladder's **14** shape and rigidity that allows movement and transportation using the same conventional transportation techniques used when the bladder is full of fluid.

As shown, the transportation bladder **14** is attached to a compressor **33** by means of a line **34** at a valve **36** located on the upper surface of the transportation bladder. In its simplest configuration, the valve **36** will be a check valve that is responsive to a lowered pressure in the space **38** between the transportation bladder **14** and the containment bladder **12** to allow high pressure air from the compressor **33** into the space and maintain the pressure at the predetermined level that keeps the transportation bladder **14** properly inflated. Once the fluid in the containment bladder **12** has been exhausted, the check valve **36** can be vented to the ambient atmosphere allowing the transportation bladder to

collapse and the resulting collapsed structure stacked with other exhausted items for shipment to a refilling center.

The compressors commonly found on trucks with air brakes and those which are part of the military fleet, have a normal operating pressure of about 65 to 130 psi. As fluid is removed from the inner containment bladder **12** the compressor **33** will begin to fill the resulting space **38** with compressed air to maintain the transport bladder's configuration. The compressor continues until the transport bladder **14** is pressurized to the point where the transport container **10** can be safely moved. In general a 65 to 85 psi should be sufficient. However if the transport container **10** is not sufficiently rigid, at these pressures additional air can be inserted until the transport container has sufficient rigidity to be safely moved.

Various alterations and modifications will become apparent to those skilled in the art without departing from the scope and spirit of this invention and it is understood this invention is limited only by the following claims.

What is claimed is:

1. A collapsible fluid transport container comprising:

a flexible containment bladder holding a quantity of fluid to be transported;

means for controlling the fluid level in the containment bladder;

a transport bladder surrounding the containment bladder; means for supplying compressed air to the transport bladder in response to the withdrawal of fluid from the containment bladder to maintain sufficient pressure in the transport bladder to retain its shape and rigidity when there is a fluid in the fluid bladder; and

securing means attached to an outer surface of the transport bladder for use in moving and securing the container to a transport mechanism.

2. The transport container of claim 1 further comprising means for transferring fluid from the flexible containment bladder to a vehicle.

\* \* \* \* \*