



**DEPARTMENT OF THE NAVY**

OFFICE OF COUNSEL  
NAVAL UNDERSEA WARFARE CENTER DIVISION  
1176 HOWELL STREET  
NEWPORT RI 02841-1708

IN REPLY REFER TO:

Attorney Docket No. 84124  
Date: 23 September 2004

The below identified patent application is available for licensing. Requests for information should be addressed to:

PATENT COUNSEL  
NAVAL UNDERSEA WARFARE CENTER  
1176 HOWELL ST.  
CODE 000C, BLDG. 112T  
NEWPORT, RI 02841

Serial Number      10/748916  
Filing Date        12/24/03  
Inventor            Kim C. Benjamin

If you have any questions please contact James M. Kasischke, Deputy Counsel, at 401-832-4736.

**DISTRIBUTION STATEMENT A**  
Approved for Public Release  
Distribution Unlimited

20041021 131

BROADBAND AND WIDE FIELD OF VIEW COMPOSITE TRANSDUCER ARRAY

TO ALL WHOM IT MAY CONCERN:

BE IT KNOWN THAT (1) KIM C. BENJAMIN, (2) STEPHEN E. FORSYTHE, employees of the United States Government and (3) KENNETH M. WALSH, citizens of the United States of America, and residents of (1) Portsmouth, County of Newport, State of Rhode Island, (2) Portsmouth, County of Newport, State of Rhode Island and (3) Middletown, County of Newport, State of Rhode Island have invented certain new and useful improvements entitled as set forth above of which the following is a specification:

JAMES M. KASISCHKE, ESQ.  
Reg. No. 36562  
Naval Undersea Warfare Center  
Division, Newport  
Newport, Rhode Island 02841-1708  
TEL: 401-832-4736  
FAX: 401-832-1231

1 Attorney Docket No. 84124

2

3 BROADBAND AND WIDE FIELD OF VIEW COMPOSITE TRANSDUCER ARRAY

4

5

STATEMENT OF GOVERNMENT INTEREST

6

7

8

9

The invention described herein may be manufactured and used by or for the Government of the United States of America for Governmental purposes without the payment of any royalties thereon or therefor.

10

11

BACKGROUND OF THE INVENTION

12

(1) Field of the Invention

13

14

15

16

The present invention relates generally to transducer arrays, and more particularly to a composite transducer array that provides a broadband frequency response over a wide field of view.

17

(2) Description of the Prior Art

18

19

A variety of sonar applications such as vehicle homing require the steering of acoustic beams over a wide field-of-view.

20

21

22

23

24

25

Existing homing array technology uses numerous narrowband and high-power longitudinal tonpilz resonators to form the aperture of an active transducer. Each tonpilz resonator consists of several active and inactive mechanical components that work together as a spring-mass, single degree-of-freedom system. Unfortunately, tonpilz resonators are expensive to fabricate and

1 offer only a limited operational bandwidth above their first  
2 length mode resonance.

3 To address operational bandwidth limitations of tonpilz  
4 resonators, recent work has focused on constructing multi-  
5 resonance tonpilz elements that have significantly greater  
6 bandwidth than that of the original single-mode tonpilz  
7 resonators. However, the fixed-size radiation head inherent to  
8 tonpilz resonators prevent their use in a "frequency agile"  
9 design in which array apertures can be varied in size.

10

11

#### SUMMARY OF THE INVENTION

12

Accordingly, it is an object of the present invention to  
13 provide a transducer array that can operate in a broadband  
14 frequency range over a wide field-of-view.

15

Another object of the present invention is to provide a  
16 broadband, wide field-of-view transducer array that is  
17 inexpensive to fabricate.

18

Other objects and advantages of the present invention will  
19 become more obvious hereinafter in the specification and  
20 drawings.

21

In accordance with the present invention, a composite  
22 transducer array has a central portion thereof formed by a  
23 piezoelectric polymer composite panel with opposing first and  
24 second surfaces. A continuous electrode is coupled to the first  
25 surface and a plurality of electrode segments electrically  
26 isolated from one another are coupled to the second surface.

1 Each electrode segment is shaped as an angular segment of a  
2 circular ring, while the plurality of electrode segments are  
3 arranged to define an array of concentric circular rings of  
4 electrode segments. Each electrode segment can be independently  
5 addressed so that the array's aperture can be varied in size.

6  
7 BRIEF DESCRIPTION OF THE DRAWINGS

8 Other objects, features and advantages of the present  
9 invention will become apparent upon reference to the following  
10 description of the preferred embodiments and to the drawings,  
11 wherein corresponding reference characters indicate corresponding  
12 parts throughout the several views of the drawings and wherein:

13 FIG. 1 is a plan view of the segmented electrode side of an  
14 embodiment of a broadband and wide field-of-view composite  
15 transducer array in accordance with the present invention;

16 FIG. 2 is a side view of the composite transducer array  
17 taken along 2-2 of FIG. 1;

18 FIG. 3 is a side view of another embodiment in which the  
19 composite transducer array is shaped or curved; and

20 FIG. 4 is a cross-sectional view of an assembly housing the  
21 composite transducer array for use in an underwater environment.

22  
23 DESCRIPTION OF THE PREFERRED EMBODIMENT(S)

24 Referring now to the drawings, simultaneous reference will  
25 be made to FIGS. 1 and 2 where a composite transducer array is  
26 shown and referenced generally by numeral 10. More specifically,

1 FIG. 1 is a plan view depicting the segmented electrode surface  
2 of the array and FIG. 2 is a side view depicting construction  
3 details of the array.

4 In FIG. 1, the segmented electrode surface of array 10 is  
5 defined by concentric circular rings of electrode segments 12.  
6 That is, each of electrode segments 12 is shaped as an angular  
7 segment (e.g., approximately 90° in the illustrated embodiment)  
8 of a circular ring of such electrode segments. Electrode  
9 segments 12 are electrically isolated from one another by means  
10 of spaces or gaps 14 therebetween. The size of spaces 14 between  
11 adjacent ones of electrode segments 12 is determined by  
12 diffraction theory as would be well understood by one of ordinary  
13 skill in the art. By way of illustrative example, four of  
14 electrode segments 12 are used to define an outermost circular  
15 ring of electrode segments. However, more or fewer electrode  
16 segments can be used in a circular ring thereof without departing  
17 from the scope of the present invention.

18 Each electrode segment 12 has a radial width  $W_R$  and an arc  
19 length  $L_A$ . Within a given circular ring of electrode segments,  
20 the radial width  $W_R$  and/or arc length  $L_A$  can be the same (as  
21 shown) or different for each electrode segment in the circular  
22 ring without departing from the scope of the present invention.  
23 For example, in the outermost circular ring illustrated in FIG.  
24 1, the radial width  $W_R$  is the same for each electrode segment 12  
25 and the arc length  $L_A$  is the same for each electrode segment 12.

1 Radial width and arc lengths can be increased or decreased with  
2 interior ones of the circular rings of electrode segments.

3 Construction of array 10 will now be explained with  
4 additional reference to FIG. 2. Electrode segments 12 are  
5 supported on a first major surface of a piezoelectric polymer  
6 composite panel 20. Details of a suitable composite panel 20 are  
7 described in U.S. Patent No. 6,255,761, the contents of which are  
8 hereby incorporated by reference. Briefly, composite panel 20 is  
9 constructed using spaced-apart piezoelectric (e.g., a  
10 ferroelectric material such as piezoceramic materials lead  
11 zirconate titanate or lead titanate) columns or rods 22 that span  
12 the thickness or height H of composite panel 20. Filling the  
13 spaces between rods 22 for the full height thereof is a  
14 viscoelastic material 24 such as a thermoplastic epoxy.

15 Each of electrode segments 12 can have a dedicated  
16 electrical lead coupled thereto. This can be accomplished by  
17 passing conductors (e.g., conductors 31 and 32 are illustrated in  
18 FIG. 2) through a side of composite panel 20. More specifically,  
19 conductors 31 and 32 are routed through viscoelastic material 24  
20 and electrically coupled to one of electrode segments 12. The  
21 second major surface of composite electrode panel 20 has a  
22 continuous electrode 40 coupled thereto. Typically, the height H  
23 of panel 20 is the same throughout so that planes defined by  
24 electrode segments 12 and continuous electrode 40 are parallel to  
25 one another.

1        Array 10 can also be shaped to conform to simple or complex  
2 contours if viscoelastic material 24 comprises a thermoplastic  
3 material such as thermoplastic epoxy. For example, as  
4 illustrated in FIG. 3, composite panel 20 has been shaped during  
5 heating thereof such that the planes defined by electrode  
6 segments 12 and continuous electrode 40 are curved in  
7 correspondence with one another.

8        The composite transducer array described herein can be used  
9 as part of an underwater array assembly such as assembly 100  
10 illustrated in FIG. 4 where like reference numerals are used to  
11 describe elements of array 10 incorporated into assembly 100. A  
12 waterproof housing (e.g., a waterproof encapsulant) 50 has array  
13 10 fitted and sealed therein such that electrode 40 is flush with  
14 and spans an opening 52 in housing 50. That is, the plane  
15 defined by continuous electrode 40 faces out of housing 50 while  
16 the plane defined by electrode segments 12 faces into housing 50.

17        Abutting electrode segments 12 is an acoustic absorbing material  
18 54 such as a particle-filled epoxy. Conductors 31 and 32 pass  
19 through both composite panel 20 (as described above) and acoustic  
20 absorbing material 54 before being coupled to appropriate signal  
21 electronics 56 that can be located within and/or outside of  
22 housing 50 as illustrated.

23        The advantages of the present invention are numerous.  
24 Broadband operation is achieved owing to the inherent broadband  
25 resonance of piezoelectric polymer composite panel 20 used to  
26 construct the transducer array of the present invention. The



1 present invention also provides an improved spatial field-of-view  
2 since numerous elements may be formed by selectively applying  
3 electrodes over the array aperture to form elements having  
4 different (non-uniform) apertures. The invention teaches element  
5 apertures that can be varied in size by simply addressing  
6 electrode segments separately. High frequency responses are  
7 achieved using small sized electrode segments. The electrode  
8 segments can be combined for low frequency responses, or larger  
9 sized electrode segments could be used. The composite transducer  
10 array can be singly or doubly curved to any reasonable radii of  
11 curvature thereby providing a cost-effective means to realize  
12 truly conforming array apertures.

13       It will be understood that many additional changes in the  
14 details, materials, steps and arrangement of parts, which have  
15 been herein described and illustrated in order to explain the  
16 nature of the invention, may be made by those skilled in the art  
17 within the principle and scope of the invention as expressed in  
18 the appended claims.

1 Attorney Docket No. 84124

2

3 BROADBAND AND WIDE FIELD OF VIEW COMPOSITE TRANSDUCER ARRAY

4

5 ABSTRACT OF THE DISCLOSURE

6 A composite transducer array comprises a piezoelectric  
7 polymer composite panel, a continuous electrode coupled to a  
8 first surface of the composite panel, and a plurality of  
9 electrically-isolated electrode segments coupled to a second  
10 surface of the composite panel. Each electrode segment is shaped  
11 as an angular segment of a circular ring. The electrode segments  
12 are arranged to define an array of concentric circular rings of  
13 electrode segments.

FIG. 1

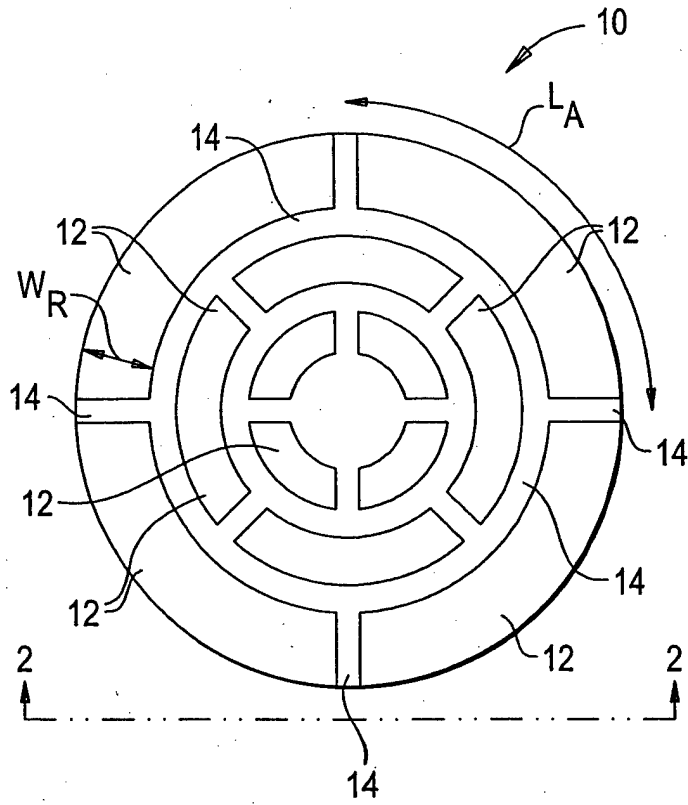

FIG. 2

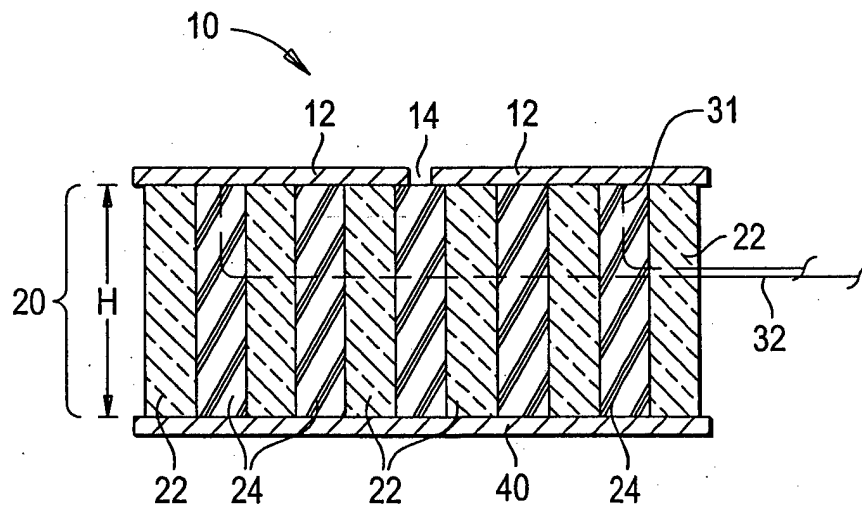

FIG. 3

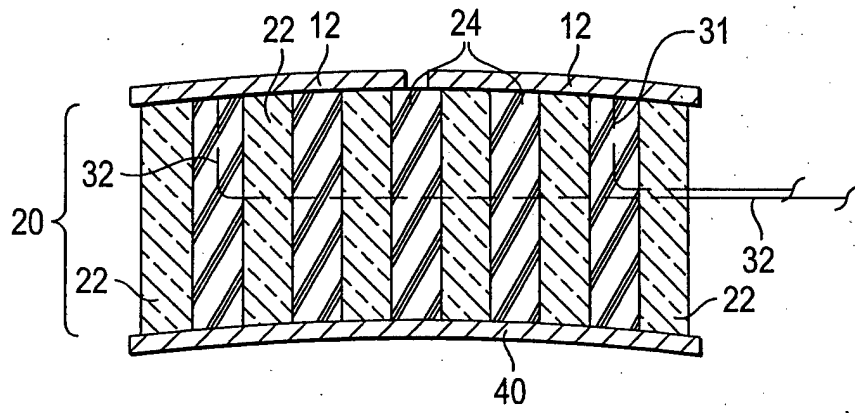

FIG. 4

