

A WINGLET FOR THE TRAILING END OF TOWED FLEXIBLE UNDERWATER LINES

TO ALL WHOM IT MAY CONCERN:

BE IT KNOWN that (1) NEIL J. DUBOIS, and (2) BRUCE E. SANDMAN, citizens of the United States of America, employees of the United States Government, and residents of (1) Cranston, County of Kent, State of Rhode Island, and (2) Tiverton, County of Newport, State of Rhode Island, have invented certain new and useful improvements entitled as set forth above, of which the following is a specification.

JAMES M. KASISCHKE, ESQ.
Reg. No. 36562
Naval Undersea Warfare Center
Division, Newport
Newport, RI 02841-1708
TEL: 401-832-4736
FAX: 401-832-1231

20040917 142



DEPARTMENT OF THE NAVY

OFFICE OF COUNSEL
NAVAL UNDERSEA WARFARE CENTER DIVISION
1176 HOWELL STREET
NEWPORT RI 02841-1708

IN REPLY REFER TO:

Attorney Docket No. 83438

Date: 23 August 2004

The below identified patent application is available for licensing. Requests for information should be addressed to:

PATENT COUNSEL
NAVAL UNDERSEA WARFARE CENTER
1176 HOWELL ST.
CODE 000C, BLDG. 112T
NEWPORT, RI 02841

Serial Number 10/825636
Filing Date 4/16/2004
Inventor Neil J. Dubois

If you have any questions please contact James M. Kasischke, Deputy Counsel, at 401-832-4736.

DISTRIBUTION STATEMENT A
Approved for Public Release
Distribution Unlimited

2

3 A WINGLET FOR THE TRAILING END OF TOWED FLEXIBLE UNDERWATER LINES

4

5 STATEMENT OF GOVERNMENT INTEREST

6 The invention described herein may be manufactured and used
7 by or for the Government of the United States of America for
8 Governmental purposes without the payment of any royalties
9 thereon or therefor.

10

11 BACKGROUND OF THE INVENTION

12 1. Field of the Invention

13 The invention relates to the movement of towed underwater
14 lines and is directed more particularly to a winglet for mounting
15 on a trailing end of such lines and operating to improve
16 stability of the line during towing.

17 2. Description of the Prior Art

18 Underwater vehicles, such as submarines and unmanned
19 underwater vehicles (UUV), may be provided with a somewhat
20 flexible line which can be paid out of the submerged vehicle and
21 towed through the water by the vehicle. Typically, the line
22 extends from a bow portion of the vehicle. The line is often
23 provided with a multiplicity of acoustic sensor elements. While
24 the line is somewhat flexible, it also exhibits some rigidity,
25 such that when the line is being towed through the water, the

1 line tends to bend rearwardly and well outwardly from the
2 vehicle.

3 The vehicle is provided with a stabilizing tether which is
4 paid out from the stern area of the vehicle and at its distal end
5 is fastened to the towed line proximate the distal end thereof.
6 The stabilizing tether is reeled in to bring the trailing end of
7 the towed line in nearer the vehicle. The tether is under
8 tension and provides some measure of stability to the towed line.

9 Nonetheless, the trailing end of the towed line is subject
10 to substantial vibration which is unwanted inasmuch as the
11 acoustic, or other measuring devices or sensors carried in the
12 towed line, may be highly position dependent. That is, to gain
13 the most from the measuring devices or sensors, it is required
14 that the precise positions of the devices be known on a
15 continuing basis. There is thus a need to diminish and limit the
16 vibrational movement of the trailing end of the towed line.

17

18 SUMMARY OF THE INVENTION

19 An object of the invention is, therefore, to steady and
20 stabilize the towed line so as to improve pin-pointing the
21 positions of instruments carried in the line.

22 With the above and other objects in view, a feature of the
23 invention is the provision of a winglet for mounting on a
24 trailing end of a flexible line to be towed by an underwater
25 vehicle. The winglet comprises an internal collar member for

1 connection to an inside surface of the line at the trailing end
2 thereof, and an outer collar member for connection to an outside
3 surface of the line outboard of the internal collar. Connection
4 means are provided for fixing the internal and outer collar
5 members to the line trailing end, and a plurality of fins are
6 mounted on an outside surface of the outer collar member and
7 extend outwardly from the outer collar member.

8 The above and other features of the invention, including
9 various novel details of construction and combinations of parts,
10 will now be more particularly described with reference to the
11 accompanying drawings and pointed out in the claims. It will be
12 understood that the particular device embodying the invention is
13 shown by way of illustration only and not as a limitation of the
14 invention. The principles and features of this invention may be
15 employed in various and numerous embodiments without departing
16 from the scope of the invention.

17

18 BRIEF DESCRIPTION OF THE DRAWINGS

19 Reference is made to the accompanying drawings in which are
20 shown illustrative embodiments of the invention, from which its
21 novel features and advantages will be apparent, wherein
22 corresponding reference characters indicate corresponding parts
23 throughout the several views of the drawings and wherein:

24 FIG. 1 is a diagrammatic representation of an underwater
25 vehicle having a flexible line extending therefrom, with a

1 winglet in accordance with the present invention fixed on a
2 trailing end of the line;

3 FIG. 2 is a sectional enlarged view of the winglet of FIG.
4 1; and

5 FIG. 3 is a sectional view, similar to FIG. 2, but
6 illustrative of an alternative embodiment.

7

8 DESCRIPTION OF THE PREFERRED EMBODIMENTS

9 Referring to FIG. 1, it will be seen that an underwater
10 vehicle 10 is provided with a hollow line 12 extending from a bow
11 area of the vehicle and in which are disposed a series of sensors
12 or measuring devices 14, typically acoustic devices. A tether 16
13 extends from the stern area of the vehicle 10 and is connected to
14 a trailing end 18 of the line 12 to stabilize the end 18, as
15 described hereinabove.

16 To further stabilize the line 12 and the devices 14, and in
17 accordance with the invention, there is provided a winglet device
18 20 for attachment to the trailing end 18 of the line 12.

19 Referring to FIG. 2, it will be seen that the winglet 20
20 includes a cylindrically shaped internal collar member 22 for
21 connection to an inside surface 24 of the line 12 proximate the
22 trailing end 18 thereof. The winglet 20 further includes a
23 cylindrically shaped outer collar member 26 for connection to an
24 outside surface 28 of the line 12 outboard of the internal collar
25 member 22.

1 Connection means 30, usually fasteners, such as bolts, are
2 provided for fixing the internal and outer collar members 22, 26
3 to the line trailing and 18, as shown in FIG. 2. Alternatively,
4 the winglet 20 may be adhesively bound to the line 12, or,
5 depending upon the material from which the winglet is made, may
6 be molded integrally with the line 12.

7 A plurality of fins 32 are mounted on an outside surface 34
8 of the outer collar member 26 and extend outwardly, or outboard,
9 from the outer collar member 26.

10 While the winglet 20 may be molded of the same material as
11 the line 12, it is presently preferred that the winglet be
12 fabricated from a light-weight, corrosion-resistant metal, such
13 as aluminum. Such a winglet, along with mechanical connection
14 means 30, facilitate use of the winglet as an "add-on" to lines
15 12 currently in use.

16 Referring to FIG. 3, it will be seen that an alternative
17 embodiment of the outer collar member 26 includes a first
18 component 36 having threads 38 at an after end thereof, and a
19 second component 40 having threads 42 thereon engageable with the
20 first component threads 38. The fins 32 are fixed to the second
21 component 40, which may be threadedly attached to and removed
22 from the first component 36 which, in turn, is fixed to the line
23 12.

24 The embodiment of FIG. 3 enables the quick and easy
25 replacement of fins, either because of damage or because of the

1 desirability of a particular fin configuration for a particular
2 task.

3 There is thus provided a winglet which may be affixed to the
4 trailing end of a line to be towed by an underwater vehicle to
5 steady and stabilize the trailing end of the towed line, to
6 improve positional accuracy of instruments carried in the line.

7 It will be understood that many additional changes in the
8 details, materials, and arrangement of parts, which have been
9 herein described and illustrated in order to explain the nature
10 of the invention, may be made by those skilled in the art within
11 the principles and scope of the invention as expressed in the
12 appended claims.

1 Attorney Docket No. 83438

2

3 A WINGLET FOR THE TRAILING END OF TOWED FLEXIBLE UNDERWATER LINES

4

5 ABSTRACT OF THE DISCLOSURE

6 A winglet for mounting on a trailing end of a flexible line
7 to be towed by an underwater vehicle includes an internal collar
8 member for connection to an inside surface of the line at the
9 trailing end thereof, an outer collar member for connection to an
10 outside surface of the line outboard of the internal collar, and
11 connection means for fixing the internal and outer collar members
12 to the line trailing end. A plurality of fins are mounted on an
13 outside surface of the outer collar member and extend outwardly
14 from the outer collar member.

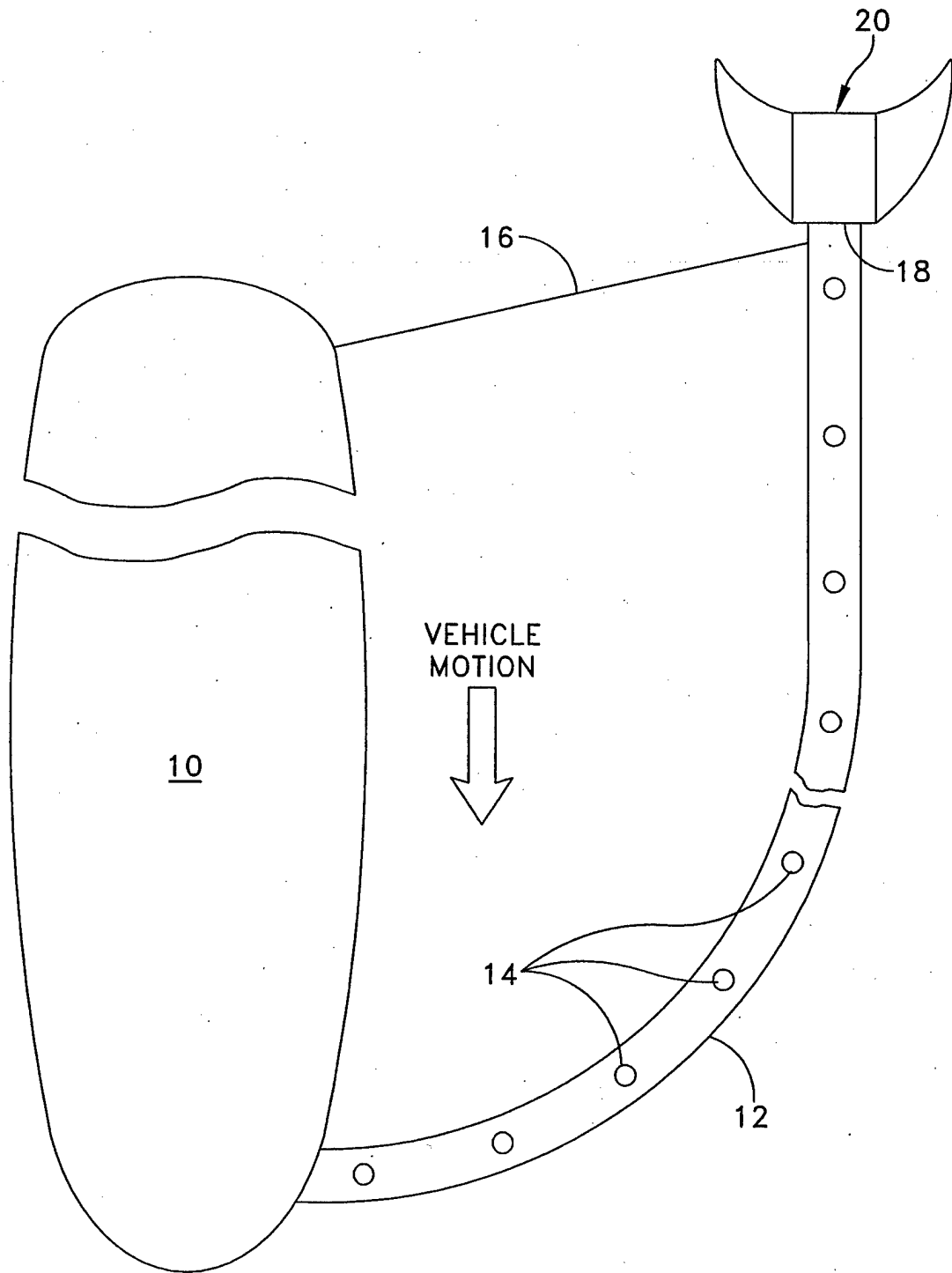

FIG. 1

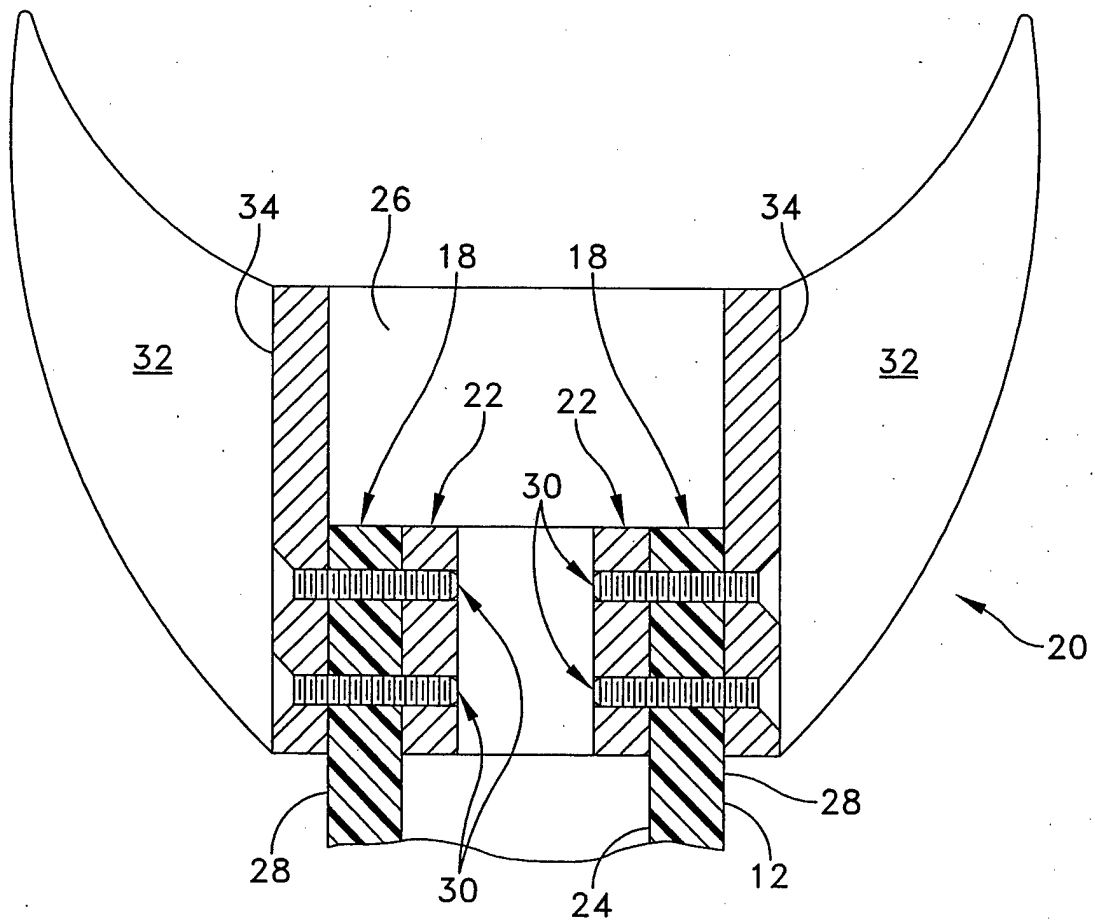

FIG. 2

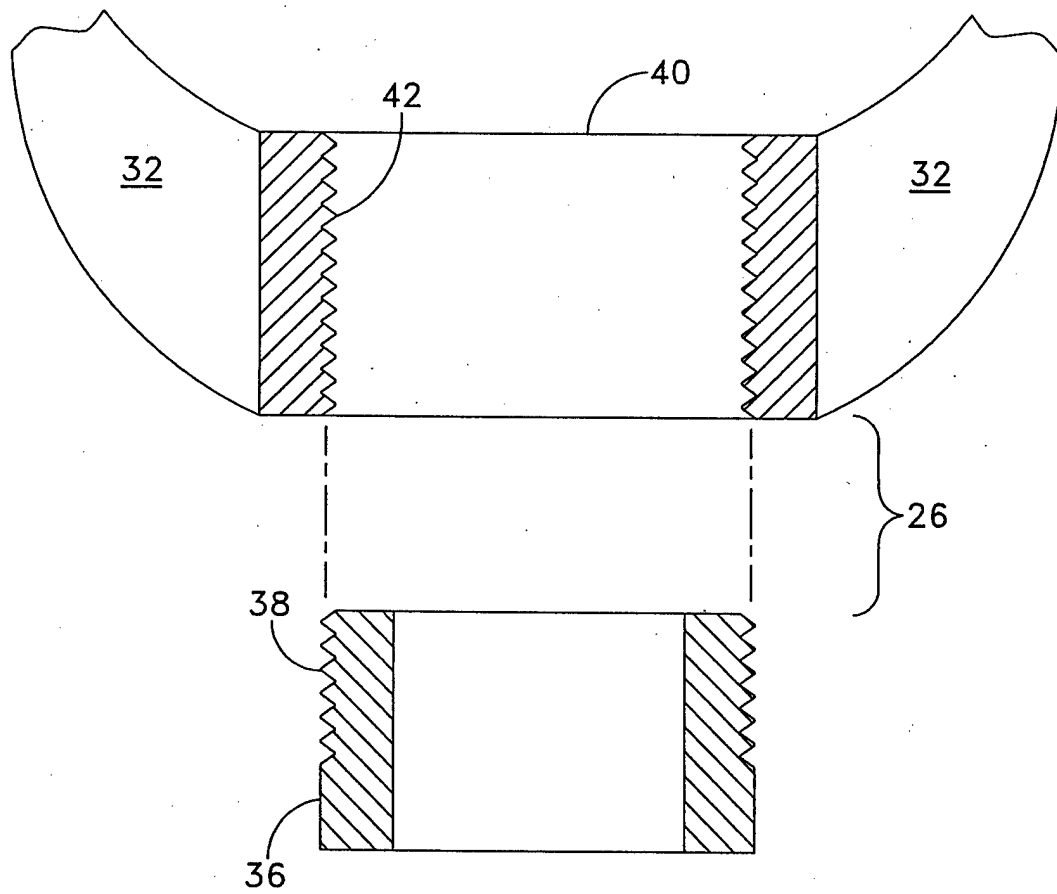

FIG. 3