



DEPARTMENT OF THE NAVY

OFFICE OF COUNSEL
NAVAL UNDERSEA WARFARE CENTER DIVISION
1176 HOWELL STREET
NEWPORT RI 02841-1708

IN REPLY REFER TO:

Attorney Docket No. 80200
Date: 5 January 2004

The below identified patent application is available for licensing. Requests for information should be addressed to:

PATENT COUNSEL
NAVAL UNDERSEA WARFARE CENTER
1176 HOWELL ST.
CODE 000C, BLDG. 112T
NEWPORT, RI 02841

Serial Number 10/663,056
Filing Date 9/15/03
Inventor Thomas S. Ramotowski et al

If you have any questions please contact James M. Kasischke, Deputy Counsel, at 401-832-4736.

DISTRIBUTION STATEMENT A
Approved for Public Release
Distribution Unlimited

A SONAR DOME AND A MOUNTING BRACKET FOR REMOVABLY CONNECTING
AN ACOUSTIC SENSOR ELEMENT TO A SONAR DOME

TO ALL WHOM IT MAY CONCERN:

BE IT KNOWN THAT (1) THOMAS S. RAMOTOWSKI and (2) PATRICK J. MONAHAN, citizens of the United States of America, employees of the United States Government, and residents of (1) Tiverton, County of Newport, State of Rhode Island, and (2) Gales Ferry, County of New London, State of Connecticut, have invented certain new and useful improvements entitled as set forth above, of which the following is a specification.

MICHAEL F. OGLO, ESQ.
Reg. No. 20474
Naval Undersea Warfare Center
Division, Newport
Newport, RI 02841-1708
TEL: 401-832-4736
FAX: 401-832-1231

20040130 174

1 Attorney Docket No. 80200

2

3 A SONAR DOME AND A MOUNTING BRACKET FOR REMOVABLY CONNECTING

4 AN ACOUSTIC SENSOR ELEMENT TO A SONAR DOME

5

6 STATEMENT OF GOVERNMENT INTEREST

7 The invention described herein may be manufactured and used
8 by or for the Government of the United States of America for
9 Governmental purposes without the payment of any royalties
10 thereon or therefor.

11

12

BACKGROUND OF THE INVENTION

13 (1) Field of the Invention

14 This invention relates to marine sonar domes, and is
15 directed more particularly to a mounting bracket for removably
16 connecting an acoustic sensor element to an inside wall of a
17 sonar dome, and to a sonar dome in which the acoustic elements
18 are so mounted.

19 (2) Description of the Prior Art

20 Sonar bow domes are commonly fixed to submarines and
21 military surface vessels beneath the water line and house
22 acoustic sensor elements and electronics which serve to alert the
23 vessel to the presence of an underwater vessel, such as a
24 submarine and/or an approaching torpedo.

1 The domes have been constructed of two steels and rubber,
2 and recently the U.S. Navy has been investigating the advantages
3 of using a fiberglass-rubber-fiberglass composite material to
4 make sonar devices for future classes of surface warships.
5 Disposed within the domes are acoustic elements positioned on
6 fixtures. The fixtures, or mounting brackets, are adhesively
7 bonded to the inside surface of the dome.

8 There is a need for a mounting bracket which securely
9 retains an acoustic element, but in a releasable fashion,
10 facilitating quick and easy replacement of a damaged element.

11 There is further a need for a mounting bracket which
12 releasably retains an acoustic element without an adhesive
13 interconnection, such that the element is free of adhesive and
14 therefore acoustically clear, so as not to interfere
15 significantly with transmissions.

16

17

SUMMARY OF THE INVENTION

18 An object of the invention is, therefore, to provide a
19 mounting bracket for fixing an acoustic element to the inside
20 wall of a sonar dome, which mounting bracket is free from
21 adhesive interconnecting bracket and the acoustic element, and is
22 adapted for quick release of a damaged element, and which
23 acoustic element is free of adhesive and is acoustically
24 transparent.

1 A further object of the invention is to provide a sonar dome
2 featuring the improved acoustic element mounting bracket.

3 With the above and other objects in view, a feature of the
4 present invention is the provision of a mounting bracket for
5 removably connecting an acoustic sensor element to an inside wall
6 of a sonar dome of a marine vessel. The mounting bracket
7 includes a first protrusion bonded at a first end thereof to the
8 inside wall of the sonar dome and extending inwardly therefrom,
9 the first protrusion being provided with a first widthwise
10 extending slot in a side thereof, the first slot being proximate,
11 but spaced from the inside wall, and a second protrusion bonded
12 at a first end thereof to the inside wall of the sonar dome and
13 extending inwardly therefrom and generally parallel to and spaced
14 from the first protrusion, the second protrusion being provided
15 with a widthwise extending second slot in a side thereof, the
16 second slot being opposed to and in alignment with the first
17 slot. The slots are adapted to receive portions of the acoustic
18 sensor element and retain the element in a position proximate to
19 and removed from the inside wall of the sonar dome. At least one
20 of the protrusions is sufficiently flexible to permit bending
21 thereof to facilitate insertion or removal of the acoustic
22 element and sufficiently rigid to snap back into a non-bent
23 configuration.

24 In accordance with a further feature of the invention, there
25 is provided a sonar dome assembly for marine vessels. The

1 assembly includes a shell for attachment to an outboard surface
2 of an underwater portion of a vessel, a plurality of mounting
3 brackets fixed to an inboard surface of the shell, and a
4 plurality of acoustic sensor elements releasably held on the
5 mounting brackets. The mounting brackets each comprise first and
6 second protrusions for retaining sensor elements mounted thereon
7 spaced from the shell inboard surface. At least one of the first
8 and second protrusions is sufficiently flexible to permit bending
9 of the protrusion to facilitate insertion of the acoustic sensor
10 element into the first and second slots, and is sufficiently
11 rigid to snap back into a non-bent configuration to lock the
12 acoustic sensor element in the first and second slots.

13 The above and other features of the invention, including
14 various novel details of construction and combinations of parts,
15 will now be more particularly described with reference to the
16 accompanying drawings and pointed out in the claims. It will be
17 understood that the particular dome and mounting bracket
18 embodying the invention are shown by way of illustration only and
19 not as limitations of the invention. The principles and features
20 of this invention may be employed in various and numerous
21 embodiments without departing from the scope of the invention.

22 23 BRIEF DESCRIPTION OF THE DRAWINGS

24 Reference is made to the accompanying drawings in which are
25 shown illustrative embodiments of the invention, from which its

1 novel features and advantages will be apparent, wherein
2 corresponding reference characters indicate corresponding parts
3 throughout the several views of the drawings and wherein:

4 FIG. 1 is a diagrammatic perspective view of a marine vessel
5 bow dome illustrative of an embodiment of the invention;

6 FIG. 2 is a front elevational view of one form of one
7 portion of a mounting bracket for removably connecting an
8 acoustic sensor element to an inside wall of a bow dome,
9 illustrative of an embodiment of the invention;

10 FIG. 3 is a side elevational view thereof;

11 FIG. 4 is a top plan view thereof;

12 FIG. 5 is a diagrammatic illustration of the connection of
13 an acoustic sensor element to a complete mounting bracket;

14 FIG. 6 is a front elevational view of the complete mounting
15 bracket with the acoustic sensor element in place;

16 FIG. 7 is a front elevational view of an alternative
17 embodiment; and

18 FIG. 8 is a perspective view of the mounting bracket of FIG.
19 6, showing a manner in which the mounting bracket may be used.

20

21 DESCRIPTION OF THE PREFERRED EMBODIMENTS

22 Referring to FIG. 1, it will be seen that a sonar dome 10
23 includes a number of acoustic elements 12, each comprising a
24 piezocomposite panel, fixed to an inside fiberglass surface 14 of
25 a fiberglass/rubber composite shell 16. Shell 16 may be made of

1 other materials which accept a bond, including fiberglass in and
2 of itself, and steel and rubber. Each element 12 is connected to
3 a canister 18 which houses the electronics for the element 12, as
4 by a wire 20 interconnecting the element 12 and the respective
5 canister 18. The canisters 18 are fixed to a supporting pedestal
6 22 in known fashion.

7 Referring to FIGS. 2-5, it will be seen that a mounting
8 bracket 24 includes a first protrusion 26 comprising a block 28
9 of, for example, polyurethane. At a first end 30 thereof, the
10 block 28 is fixed to the shell inside surface 14, as by an epoxy
11 resin or other suitable adhesive system. The block 28 is
12 provided with a widthwise slot 32 and, optionally, a bore 34.

13 As shown in FIGS. 5 and 7, the mounting bracket 24 includes
14 a second protrusion 36 comprising a block 38, typically of the
15 same material as the block 28 (FIG. 3), and provided with a first
16 end 40 fixed to the shell inside surface 14, a widthwise slot 42
17 opposed to the slot 32 of the block 28, and, optionally, a bore
18 44 whose purpose is discussed hereinbelow.

19 In FIGS. 5-7, it will be seen that the two blocks 28, 38 are
20 adapted to receive in their respective slots 32, 42 an acoustic
21 element 12. The blocks, if both of polyurethane, are
22 sufficiently flexible to be manually deformed sufficiently for
23 the element 12 to be wedged into the slots 32, 42. Upon release
24 of the blocks 28, 38, the blocks snap back into parallel
25 positions, holding the element 12 therebetween (FIG. 6).

1 The blocks 28, 38 may be of a harder, firmer material, such
2 as a polycarbonate resin, but it is critical that at least one of
3 the blocks be sufficiently flexible to permit removal of an
4 element 12 and insertion of a replacement element. It is further
5 critical that the material of the blocks be acoustically "clear"
6 material and of a material which can be bonded to fiberglass or
7 other bondable material of which the shell is made.

8 Referring to FIG. 7, it will be seen that the mounting
9 bracket 24 may include a restraining member 46 which may comprise
10 a threaded PVC restraint rod 48 extending through the bores 34,
11 44 and secured by PVC units 50. Depending upon the flexibility
12 of the blocks 28, 38, other restraining members, such as spring
13 clips, nylon tips, rubber bands, and the like (not shown), may be
14 used. The use of restraints and, if so, the selection of
15 restraints, depends in large measure on the flexibility of the
16 protrusions 26, 36 and the dynamic loading expected.

17 As shown in FIG. 8, each block slot 32, 42 can receive
18 corner portions of two elements 12, 12a.

19 As may be seen in FIG. 6, the acoustic element 12 is
20 positioned by the protrusions 26, 36 a selected distance from the
21 inside surface 14 of the shell 16. Inasmuch as the dome 10 is
22 free-flooded, the area between the element and the inside surface
23 of the shell will present a layer of sea water, assuring
24 excellent acoustic coupling between the elements and the nearby
25 dome wall. In a preferred embodiment of the invention, the

1 stand-off distance from the inside surface is of the order of
2 1/8th inch.

3 There is thus provided a sonar dome of improved construction
4 and performance, and mounting brackets therein for the acoustic
5 elements, which mounting brackets are free from adhesive
6 interconnection to the elements, retain the elements securely but
7 in readily releasable fashion, which elements are of acoustically
8 transparent material, and which dome construction provides a
9 layer of sea water between the elements and the proximate dome
10 wall.

11 It will be understood that many additional changes in the
12 details, materials, and arrangement of parts, which have been
13 herein described and illustrated in order to explain the nature
14 of the invention, may be made by those skilled in the art within
15 the principles and scope of the invention as expressed in the
16 appended claims.

2

3 A SONAR DOME AND A MOUNTING BRACKET FOR REMOVABLY CONNECTING
4 AN ACOUSTIC SENSOR ELEMENT TO A SONAR DOME

5

6 ABSTRACT OF THE DISCLOSURE

7 A mounting bracket for removably connecting an acoustic
8 sensor element to an inside wall of a sonar dome of a marine
9 vessel includes a first protrusion bonded at a first end thereof
10 to the inside wall of the sonar dome, extending inwardly
11 therefrom, and provided with a first widthwise extending slot
12 proximate, but spaced from, the inside wall, and a second
13 protrusion bonded at a first end to the sonar dome inside wall
14 and extending generally parallel to and spaced from the first
15 protrusion, the second protrusion being provided with a widthwise
16 extending second slot in a side thereof, the second slot being
17 opposed to and in alignment with the first slot. The slots are
18 adapted to receive portions of the acoustic sensor element and to
19 hold the acoustic sensor element in a position proximate to and
20 removed from the inside wall of the sonar dome.

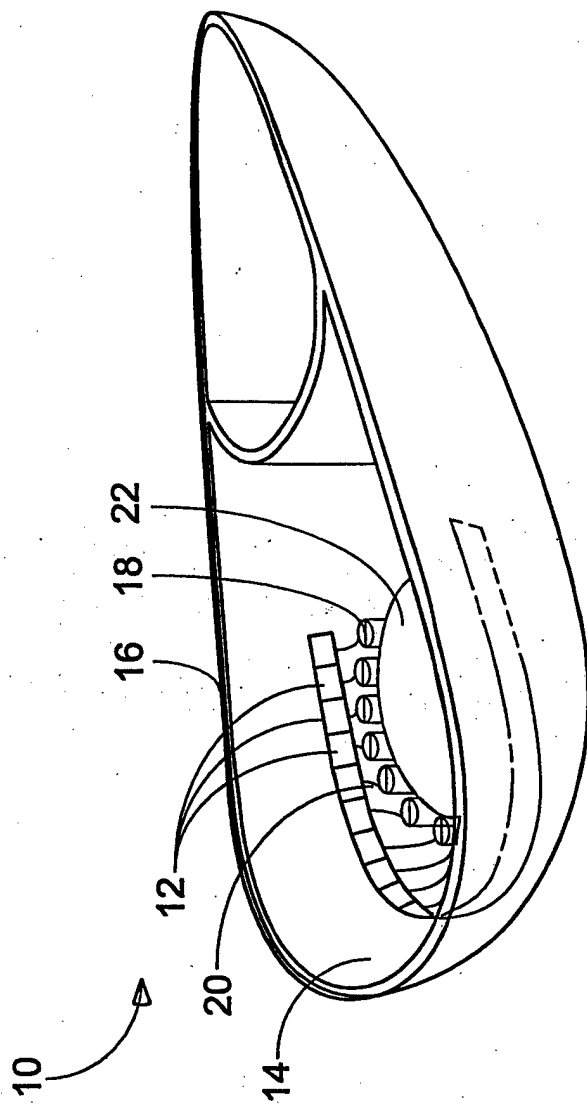

FIG. 1

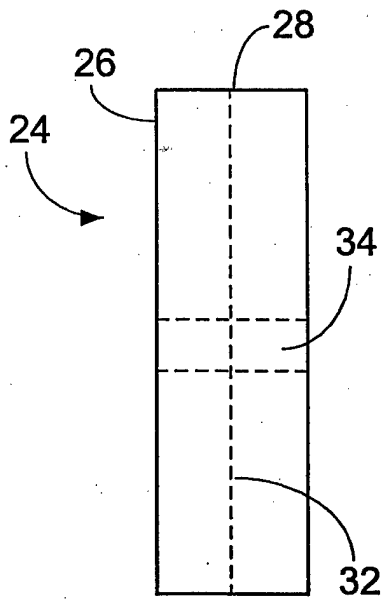

FIG. 4

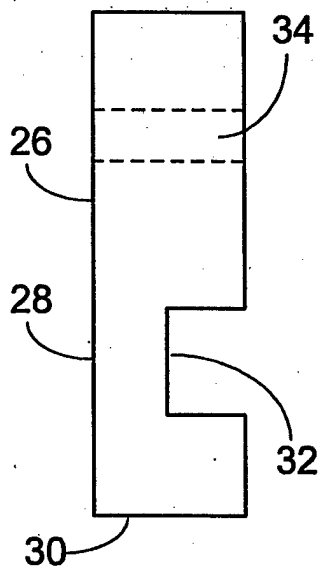

FIG. 2

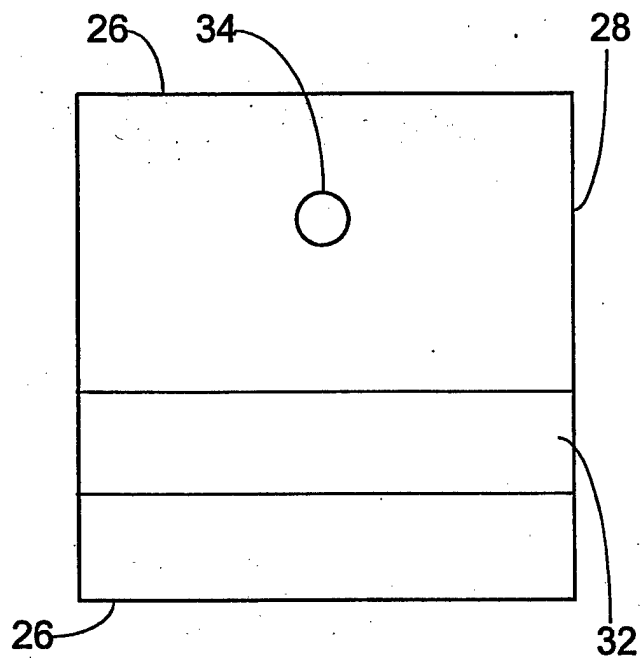

FIG. 3

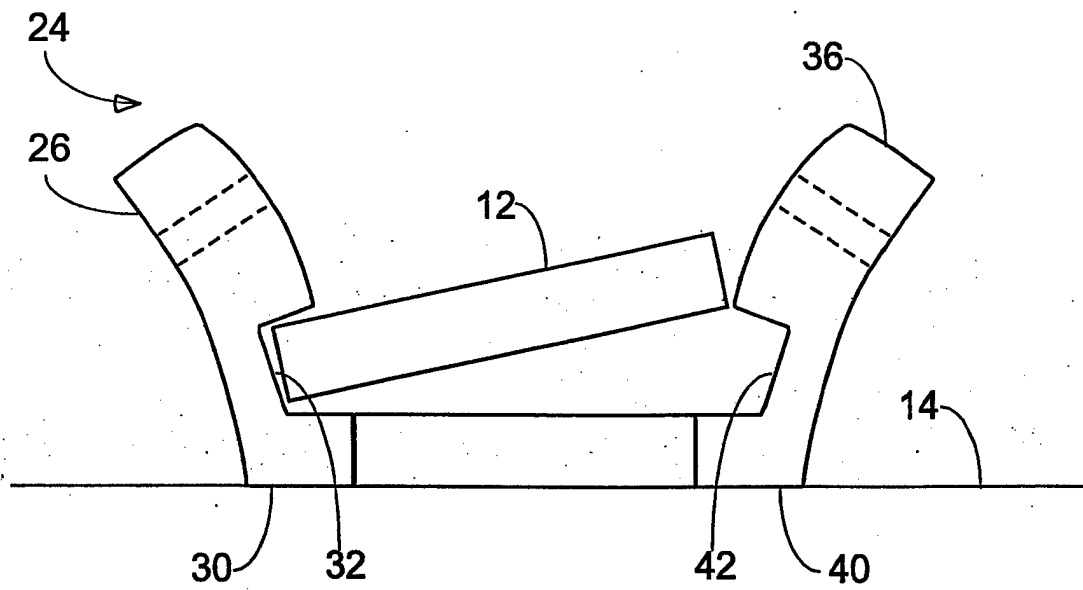

FIG. 5

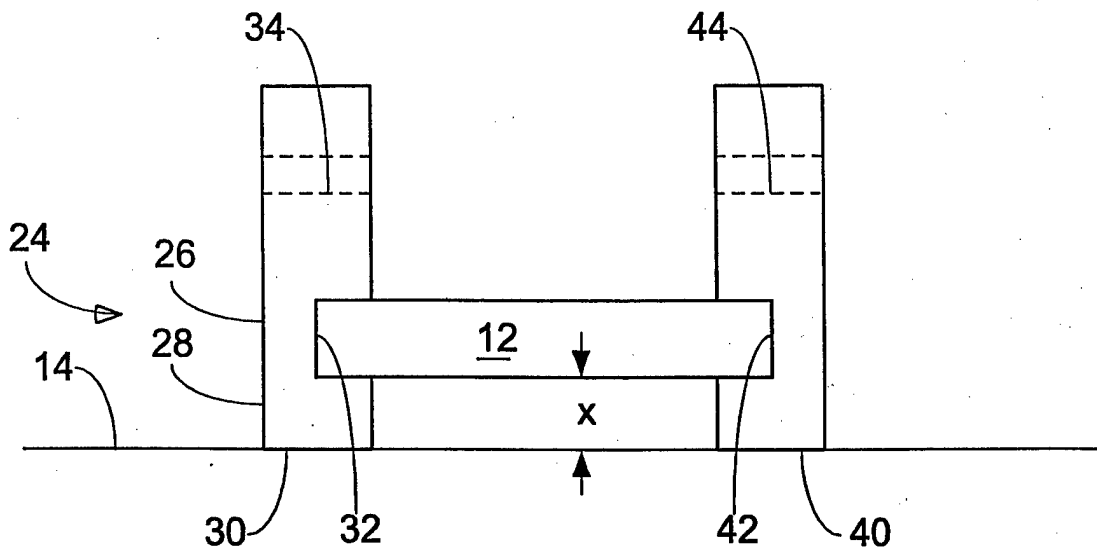

FIG. 6

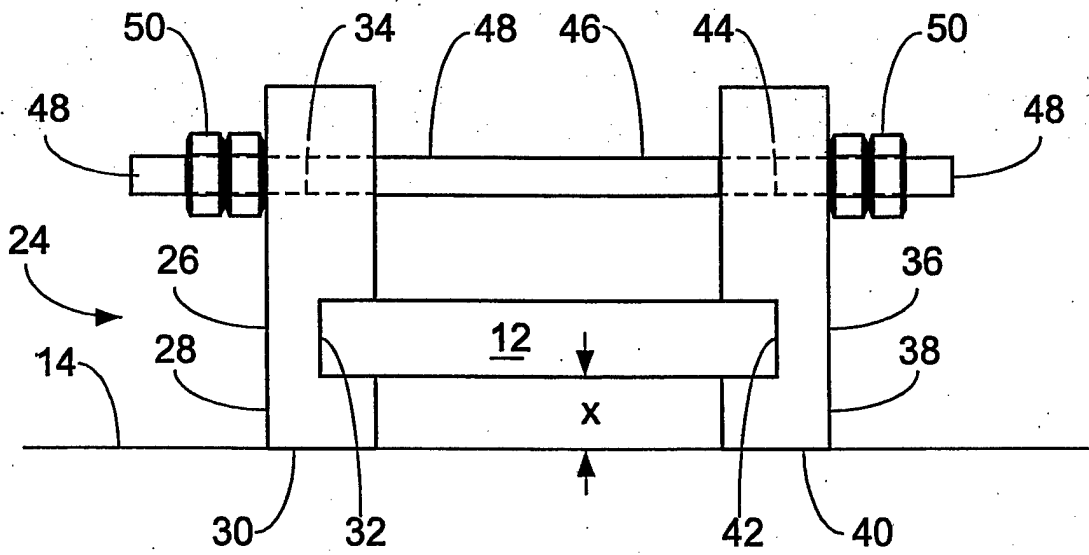

FIG. 7

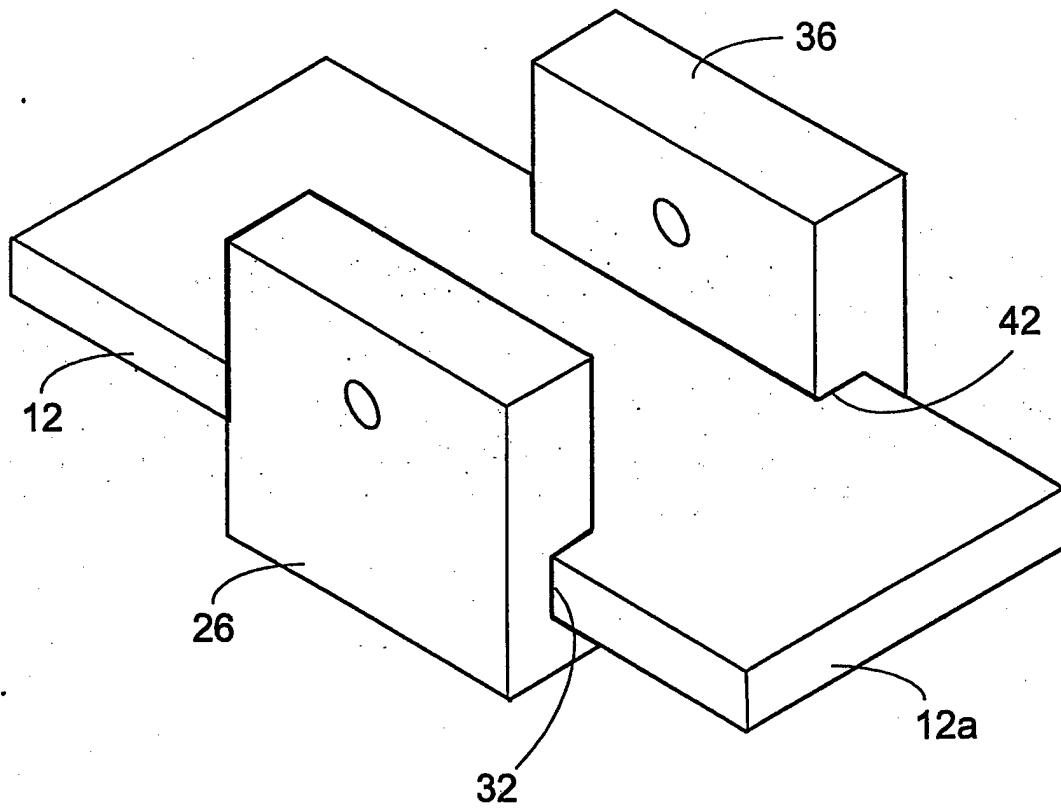

FIG. 8