

DISTRIBUTION STATEMENT A
Approved for Public Release
Distribution Unlimited

10 Oct 2001

SELF ADJUSTING NEUTRAL BUOYANCY COUNTERMEASURE AND SYSTEM

TO ALL WHOM IT MAY CONCERN:

BE IT KNOWN THAT NEIL J. DUBOIS, citizen of the United States of America, employee of the United States Government, resident of Cranston, County of Providence, State of Rhode Island, has invented certain new and useful improvements entitled as set forth above of which the following is a specification:

JAMES M. KASISCHKE, ESQ.
Reg. No. 36562
Naval Undersea Warfare Center
Division, Newport
Newport, RI 02841-1708
TEL: 401-832-4736
FAX: 401-832-1231

20020322 175



23523

PATENT TRADEMARK OFFICE



DEPARTMENT OF THE NAVY
OFFICE OF COUNSEL
NAVAL UNDERSEA WARFARE CENTER DIVISION
1176 HOWELL STREET
NEWPORT RI 02841-1708

IN REPLY REFER TO:

Attorney Docket No. 82723
Date: 8 March 2002

The below identified patent application is available for licensing. Requests for information should be addressed to:

PATENT COUNSEL
NAVAL UNDERSEA WARFARE CENTER
1176 HOWELL ST.
CODE 000C, BLDG. 112T
NEWPORT, RI 02841

Serial Number 09/977,905
Filing Date 10 October 2001
Inventor Neil J. Dubois

If you have any questions please contact Michael J. McGowan, Patent Counsel, at 401-832-4736.

2

3 SELF ADJUSTING NEUTRAL BUOYANCY COUNTERMEASURE AND SYSTEM

4

5 STATEMENT OF GOVERNMENT INTEREST

6 The invention described herein may be manufactured and used
7 by or for the Government of the United States of America for
8 governmental purposes without the payment of any royalties
9 thereon or therefor.

10

11 CROSS REFERENCE TO OTHER PATENT APPLICATIONS

12 Not applicable.

13

14 BACKGROUND OF THE INVENTION

15 (1) Field of the Invention

16 This invention generally relates to a self adjusting
17 neutral buoyancy countermeasure and system for underwater
18 devices.

19 More particularly, the invention relates to a self
20 adjusting neutral buoyancy mechanism which effects slight
21 changes in an overall displacement of an underwater body, and
22 thereby adjusts a buoyancy force of the body.

1 (2) Description of the Prior Art

2 The current art for devices required to maintain certain
3 depths is known. These include military devices such as torpedo
4 countermeasures and oceanographic survey devices. Acoustic
5 countermeasures are particularly utilized to confuse hostile
6 sonar systems and protect existing force assets. Typical
7 countermeasures are launched from a submarine platform and use
8 an active system to traverse to a predetermined depth, maintain
9 a hovering depth, and begin operation. The known military
10 devices utilize a propeller system or a variable pressure gasbag
11 system to maintain a predetermined depth; however, these systems
12 require active manipulation to maintain their position. In
13 general the devices themselves are slightly negatively buoyant,
14 thus requiring a means of providing additional upward force to
15 maintain depth and prevent the device from free-falling to the
16 ocean bottom.

17 A propeller system for an acoustic countermeasure device 10
18 is shown by way of example in FIG. 1. In the case of FIG. 1,
19 constant power is used to maintain the thrust that holds the
20 device 10 at a predetermined depth D. The device 10 is
21 comprised of a body tube 12 which houses power and electronics,
22 a transducer section 14 which produces the acoustic power, and a
23 hovering system 16 which provides thrust and keeps the device at
24 the prescribed depth D in the underwater environment 18. Thus,

1 a problem exists in the art whereby the space and energy
2 requirements for deploying and maintaining depth of one or more
3 underwater devices, such as an acoustic countermeasure device,
4 should be minimized.

5 This invention describes a countermeasure as a single
6 device and as a system which encompasses the traditional
7 acoustic traits of countermeasures along with a novel hovering
8 system and the use of multiple numbers of these countermeasure
9 devices simultaneously. The invention disclosed here is
10 designed to work on a body that is essentially neutrally buoyant
11 by design, and requires only slight changes to effect depth
12 control. Further, the invention herein utilizes a more passive
13 device for maintaining a predetermined depth which takes less
14 volume, weight and power than traditional methods. The savings
15 in weight, volume and power should allow for a device design
16 that is essentially neutrally buoyant on its own, thus requiring
17 only small changes in buoyancy to effect depth change.

18 The following patents, for example, disclose various types
19 of depth adjusting devices, but do not disclose a novel hovering
20 mechanism allowing a submerged device to adjust and to maintain
21 a desired depth as does the present invention.

22 U.S. Patent No. 2,790,186 to Carapellotti;

23 U.S. Patent No. 4,286,539 to Pignone; and

24 U.S. Patent No. 4,364,325 to Bowditch.

1 Specifically, Carapellotti discloses a buoy having an upper
2 enclosed chamber housing a weight therein and a lower chamber
3 joined to the upper chamber. The lower chamber has an open end
4 remote from the upper chamber and a weight therein adapted to
5 pass through the opening. A first removable closure member and
6 a second closure member are provided for the opening, the second
7 closure member being disposed in the lower chamber above the
8 weight. Flexible means connect the weight and the second
9 closure member, and orifices are provided in the lower chamber
10 near the top thereof. When the first closure member is removed
11 from the opening and the buoy is floated, the weight will pass
12 through the opening and be suspended beneath the buoy by the
13 flexible means, the second closure member will lodge on and seal
14 the opening, and the lower chamber will become substantially
15 filled with water.

16 The patent to Pignone discloses a dual buoyancy device
17 having two external dimensions, in the smaller of which, one end
18 is closed by an elastic sheet undistended, and in the greater of
19 which the sheet is distended from its normal position thereby
20 increasing the external dimension of the device. The distention
21 of the sheet is accomplished by a thruster member bearing on the
22 sheet which thruster is impelled by a weight and lever system
23 actuated by gravity, which causes the thruster to distend the
24 sheet. When the sheet is distended, the overall volume

1 increases causing the device to float. When the sheet is
2 undistended, the overall volume decreases causing the device to
3 sink. Distension of the sheet via the thruster only occurs when
4 the device is inverted. Still further, there is no neutral
5 buoyancy capability. The device either sinks or floats.

6 Bowditch discloses a passive near neutral buoyancy platform
7 including a structure housing a series of gas-filled cells,
8 restrained in their maximum volume regardless of the internal
9 charge pressure, and collapsible in character when external
10 pressure exceeds the charge pressure. With this structure, once
11 a cell having a predetermined initial internal charge pressure
12 reaches a depth where the external pressure exceeds this initial
13 value, that cell contracts, resulting in a net buoyancy change
14 for the structure. Where this series of cells is attached
15 integrally to a single structure, the cells form a pre-loaded
16 compressibility compensation device matched to the external
17 environment.

18 It should be understood that the present invention would in
19 fact enhance the functionality of the above patents by providing
20 a displacement mechanism for an underwater body in which the
21 displacement mechanism changes the total displacement of the
22 body and thereby adjusts a buoyancy force of the body. This
23 is done in the present invention on a substantially neutrally

1 buoyant device and without the use of a known propeller system
2 or a variable pressure gas bag system.

3

4

SUMMARY OF THE INVENTION

5 Therefore it is an object of this invention to provide a
6 self adjusting neutral buoyancy device.

7 Another object of this invention is to provide a self
8 adjusting neutral buoyancy device deployed as a system of
9 devices.

10 Still another object of this invention is to provide a self
11 adjusting neutral buoyancy device having a mechanism for
12 changing a sealed volume of the device and thereby adjusting a
13 depth at which neutral buoyancy occurs.

14 A still further object of the invention is to provide a
15 self adjusting neutral buoyancy device which may be incorporated
16 into any underwater neutrally buoyant device.

17 Yet another object of this invention is to provide a self
18 adjusting neutral buoyancy device which is less costly and
19 requires less space than known devices.

20 In accordance with one aspect of this invention, there is
21 provided an underwater self adjusting displacement device
22 including a sealed housing having an exterior wall and an inner
23 component area, the exterior wall having an opening formed
24 therein. A sealing plug is slidably seated in the opening of

1 the exterior wall, and an actuator mechanism selectively adjusts
2 the sealing plug within the opening, thereby adjusting a total
3 displacement of the sealed housing. The displacement device is
4 incorporated into any substantially neutrally buoyant underwater
5 deployable device such as an acoustic countermeasure device or
6 an oceanographic sensor device. Further, the deployable devices
7 may be deployed individually or as a field. The displacement
8 device requires less weight and weight within an overall
9 deployed device, enabling large deployments and performance
10 enhancements.

11
12 BRIEF DESCRIPTION OF THE DRAWINGS

13 The appended claims particularly point out and distinctly
14 claim the subject matter of this invention. The various
15 objects, advantages and novel features of this invention will be
16 more fully apparent from a reading of the following detailed
17 description in conjunction with the accompanying drawings in
18 which like reference numerals refer to like parts, and in which:

19 FIG. 1 is a side view of an underwater acoustic
20 countermeasure device according to the Prior Art;

21 FIG. 2 is a side sectional view of a buoyancy displacement
22 device according to a preferred embodiment of the present
23 invention;

1 FIG. 3 is a side sectional view of a buoyancy displacement
2 device according to a further preferred embodiment of the
3 present invention;

4 FIG. 4 is a side sectional view of a generic underwater
5 device for use with the preferred embodiments of the present
6 invention;

7 FIG. 5 is a side sectional view of an acoustic
8 countermeasure device for use with the preferred embodiments of
9 the present invention; and

10 FIG. 6 is a side view of a field of countermeasure devices
11 deployed simultaneously according to the present invention.

12

13 DESCRIPTION OF THE PREFERRED EMBODIMENT

14 In general, the present invention is directed to a
15 mechanism which allows for a submerged device to adjust and
16 maintain a certain depth. Examples of devices which are
17 required to remain submerged at specific depths include military
18 devices such as torpedo countermeasures and oceanographic
19 devices which float submerged for long periods of time and map
20 ocean currents. This invention accomplishes a volumetric
21 displacement change in a submerged body which can alter and
22 maintain floating at a certain depth.

23 The invention is a mechanism to adjust and maintain depth
24 for a submerged underwater device. It is designed to operate on

1 a device which is essentially neutrally buoyant and requires
2 only slight changes in its displacement/buoyancy to effect depth
3 control. The variable density of seawater due to pressure as
4 depth increases allows for bodies to float at a constant depth
5 beneath the surface. Slight changes in the body's overall
6 displacement can affect its buoyancy, and thereby its depth.
7 This mechanism allows for changing the total displacement of a
8 body and thereby an adjustment in buoyancy force.

9 Turning now to FIG. 2, a first preferred embodiment of a
10 displacement device 20 is shown. It will be understood from the
11 following that the described displacement device 20 is
12 applicable to a number of end uses such as the acoustic
13 countermeasure device or oceanographic devices which float
14 submerged for long periods of time and map ocean currents.
15 These end uses are mentioned by way of example only and are not
16 intended to limit the end uses of the present invention.

17 The displacement device 20 includes a shell or body portion
18 22, the body portion 22 being closed and sealed to provide a
19 displacement of seawater and resulting buoyancy force. The body
20 portion 22 has an outer surface 24 in contact with the sea
21 water, and an inner wall surface 25 defining an inner chamber 26
22 for housing components of the displacement device 20. An
23 opening 28 is formed through the body portion 22, the opening
24 being defined by an inner wall surface 30. A displacement

1 mechanism 32 is provided in connection with and sealed against
2 the opening 28 of the body portion 22. The displacement
3 mechanism 32 is sealed with the opening 28 so as to preserve the
4 watertight integrity of the displacement device 20 as will be
5 further described in the following.

6 The displacement mechanism 32 particularly includes a plug
7 member 34 having an outer peripheral shape corresponding to the
8 shape of the inner wall surface 30. The plug member 34 is
9 sealed against the wall surface 30 with an O-ring seal 36
10 therearound. This seal 36 slides with the plug 34 to create a
11 change in the overall displacement of the underwater device 20.

12 This sliding motion of the plug 34 and seal 36 is created
13 by a linear actuator 38 mounted to the inner surface 25 of the
14 body portion 22 by a bracket 40 and bolts 42. An actuator shaft
15 44 is interconnected between the actuator 38 and the plug 34 and
16 allows for controllable motion to be imparted from the actuator
17 38 to the plug 34. The bracket 40 is shown as having a flange
18 40b extending radially from a central shaft type housing 40a.
19 The flange 40b is flush with the inner surface 25 of the body 22
20 adjacent the opening 28. Although the bracket 40 having the
21 housing 40a and flange 40b is illustrated, it should be
22 appreciated that the bracket 40 may be of any suitable shape and
23 attached in any known manner to the inner surface 25 of the body
24 portion 22 of the device. Further, although the displacement

1 device 20 is shown to utilize cylindrical parts for the plug 34
2 and the opening 28, these shapes are not intended to limit the
3 invention.

4 Turning now to FIG. 3, an alternative displacement
5 mechanism 46 is shown as another preferred embodiment. Like
6 reference numbers refer to like parts throughout this
7 specification. Accordingly, the body portion 22 having an
8 opening 28 with an inner wall surface 30 formed therein remains
9 the same as in FIG. 2. A displacement plug 48 is located
10 concentrically within the opening 28 of the body 22 and includes
11 an O-ring seal 50 formed therearound. The displacement plug 48
12 is formed to include an opening 52 on an inner surface thereof,
13 the opening terminating in a cavity 54 within the plug 48 as
14 shown.

15 The displacement plug 48 along with its seal 50 slides
16 within the wall surface 30 of the body portion 22 to create a
17 change in the overall displacement of the underwater device 20.
18 This sliding motion of the plug 48 and seal 50 is created by a
19 motor 56, a drive gear 58, and a power screw 60 engaged with
20 drive gear 58. The motor 56 is connected to the drive gear 58
21 with an intermediary shaft 62. The power screw 60 includes an
22 elongated shaft portion 60a having gear threads 60b at one end
23 thereof and a plate 60c attached to the other end thereof. The
24 plate portion 60c is seated within the cavity 54 of the

1 displacement plug 48 such that the displacement plug 48 moves in
2 response to movement of the plate portion 60c. Rotation of the
3 drive gear 58 translates to linear movement of the power screw
4 60 by engagement of the drive gear 58 with the threads 60b of
5 the power screw 60. Power screw 60 and plate portion 60c can
6 rotate when moved by drive gear 58 without requiring rotation of
7 plug 48 and seal 50. These incremental linear movements of the
8 power screw 60 generate a corresponding motion of the plug 48
9 and seal 50. Other means of achieving the translation of the
10 seal plug 48, such as by use of a worm gear and rack or the
11 like, may be affected by one of ordinary skill in the art and is
12 intended to be included within the scope of the invention.

13 Similar to the embodiment of FIG. 2, the assembly is fixed
14 to the inner surface of the body 22 with a bracket 64, 66 and
15 bolts 68. The bracket assembly includes a substantially
16 vertical bracket portion 64 and a substantially horizontal
17 bracket portion 66. The vertical bracket portion 64 supports
18 the motor 56 of the displacement mechanism and the horizontal
19 bracket portion 66 is flush with the inner surface 25 of the
20 body for mounting thereto with the bolts 68. At least a portion
21 of the horizontal bracket 66 extends as an inner flange 66a to
22 cover the opening 28 of the body portion 22, such that the power
23 screw 60 fits through an opening 66c thereof as shown. An outer

1 flange portion 66b of the horizontal bracket 66 is used to
2 attach the bracket to the inner surface 25 of the shell 22.

3 Adjustments of the plug 48 position in the opening 28 of
4 the shell 22 changes the overall buoyancy of the device 20 since
5 the displacement changes while the overall weight of the device
6 remains constant.

7 With the invention as described in FIGS. 2 and 3, there is
8 achieved a controllable change in depth for an underwater
9 floating device 20 through a small change in buoyancy. This is
10 done in a manner to only consume very small quantities of energy
11 to effect the change. Also, once the depth is attained, no
12 further changes to the system are required to maintain near term
13 depth and the system becomes truly passive. For extended time
14 durations, movement of the device to water of different
15 temperature or salinity may require further active adjustments.

16 Referring now to FIG. 4, there is shown a generic
17 underwater device 70 having a shell type body portion 72 as
18 described in connection with FIGS. 2 and 3. The body portion 72
19 is assumed to be closed and sealed, providing a displacement of
20 seawater and resulting buoyancy force. Positioned within the
21 device 70 is a displacement mechanism 74 such as that described
22 in connection with either of FIGS. 2 or 3. The displacement
23 mechanism 74 is sealed against the shell 72 to preserve
24 watertight integrity. Also located within the shell body 72 are

1 a pressure sensor 76, a salinity meter 78, and a controller 80.
2 Other instrumentation such as accelerometers or motion detectors
3 can also be provided and joined to controller 80. By using the
4 inputs of the pressure sensor 76 as a measure of depth and the
5 salinity meter 78 as a measure of salt content (which affects
6 buoyancy) the controller 80 can monitor the environmental
7 variables and adjust the system through a commanded position for
8 the displacement mechanism 74.

9 The displacement mechanism 74 functions in the same manner
10 as described in either of FIGS. 2 or 3. The system 70 utilizes
11 commercial components for depth pressure sensing and salinity
12 measurements. A control algorithm developed to relate pressure,
13 salinity, and position control of the displacement mechanism in
14 order to achieve and maintain a prescribed depth can be
15 implemented using a relatively simple control circuit. Power
16 can be supplied through a battery, and likely would be supplied
17 by whatever power source is energizing the device's other
18 functions.

19 Referring next to FIG. 5, there is illustrated an acoustic
20 countermeasure device 82 utilizing a displacement mechanism 84
21 according to the present invention as described in either of
22 FIGS. 2 or 3.

23 The acoustic countermeasure 82 is utilized as a decoy and
24 jammer in undersea warfare. Acoustic signals are transmitted

1 which can confuse the sonar systems of hostile torpedoes and
2 submarines. Similar to the previous figures, the acoustic
3 countermeasure device 82 includes a shell type body 86 having an
4 opening 88 therein for receiving the displacement mechanism 84.
5 The shell body 86 includes an interior chamber 90 for
6 accommodating operating elements of the device 82. As shown in
7 the FIG. 5, transducers 92 are mounted on or in the walls of the
8 shell body 86 and produce the acoustic signals. A battery power
9 source 94 and signal electronics 96 are located within the
10 chamber 90 and provide the power and signals for driving the
11 transducers 92. These systems are similar to current acoustic
12 systems used in countermeasure devices.

13 Similar to that of FIG. 4, the acoustic countermeasure
14 device 82 includes a salinity meter 98 and a pressure sensor
15 100. A controller 102 coordinates the information gathered from
16 the salinity meter 98 and pressure sensor 100 in a manner
17 identical to that described above for FIG. 4. This system
18 incorporates the traditional acoustic transducers and
19 electronics which supply the sound into the water which is the
20 product of an acoustic countermeasure. The details will be
21 eliminated herein for brevity.

22 Referring now to FIG. 6, a field of acoustic countermeasure
23 devices 82 is shown to be deployed as a substantially
24 simultaneous event. Due to the volume saved by the novel

1 buoyancy system, it is anticipated that multiple countermeasure
2 devices can be launched using the volume previously required for
3 a single device. As such, the application of simultaneously
4 dispersed fields of countermeasures becomes an available option.
5 These countermeasures can all be set to hover at different
6 depths (D1, D2, D3). Additionally, delays in launching while
7 the launch platform is in motion will provide spatial
8 separations (S1, S2). The net effect is a series of acoustic
9 sources at different depths and locations. This can cause a
10 threat weapon or platform to rule out multiple sources as decoys
11 rather than one. If the countermeasures 82 are employing
12 different frequency bands in their transmissions, additional
13 processing problems for the threat assets arise.

14 Incorporated into each of the countermeasures 82 of FIG. 6
15 is the novel displacement mechanism of FIG. 2 or 3 to achieve
16 and maintain a prescribed depth of the individual
17 countermeasures which together make up the system. The variable
18 density of seawater due to pressure as depth increases and
19 changes in temperature allows for bodies to float at a constant
20 depth beneath the surface. Slight changes in the body's overall
21 displacement can affect its buoyancy, and thereby its depth.
22 This system allows for changing the total displacement of a body
23 and thereby an adjustment in buoyancy force to achieve and
24 maintain a desired depth by an underwater device.

1 The arrangement of FIG. 6 is advantageous in that it
2 provides a multiple acoustic countermeasure system which
3 presents multiple acoustic sources/frequencies to confuse
4 incoming threats.

5 Through an acoustic countermeasure system as described, the
6 overall device may be made smaller than traditional devices due
7 to the weight, volume, and power savings afforded by the novel
8 depth control system. This may make available the option to
9 package two devices into the launch apparatus currently used to
10 deploy one device.

11 The exact number of countermeasures used in the multiple
12 countermeasure system can vary. The number available and
13 mission specifics will affect launch numbers and individual
14 depth/frequency assignments.

15 The tolerance for depth accuracy and the time duration of
16 the device mission can alter the control system components. If
17 a short duration mission is required, and the area of the ocean
18 known, then the need to measure and monitor salinity is reduced
19 and this aspect of the control system could be omitted.
20 Further, the specific mission of the countermeasure will
21 influence the choice of transducers and the requisite power
22 levels.

23 In view of the above detailed description, it is
24 anticipated that the invention herein will have far reaching

1 applications other than those of underwater systems such as
2 acoustic countermeasures and oceanographic devices.

3 This invention has been disclosed in terms of certain
4 embodiments. It will be apparent that many modifications can be
5 made to the disclosed apparatus without departing from the
6 invention.

1 Attorney Docket No. 82723

2

3 SELF ADJUSTING NEUTRAL BUOYANCY COUNTERMEASURE AND SYSTEM

4

5 ABSTRACT OF THE DISCLOSURE

6 An underwater self adjusting displacement device includes
7 a sealed housing having an exterior wall and an inner component
8 area, the exterior wall having an opening formed therein. A
9 sealing plug is slidably seated in the opening of the exterior
10 wall, and an actuator mechanism selectively adjusts the sealing
11 plug within the opening, thereby adjusting a total displacement
12 of the sealed housing. The displacement device is incorporated
13 into any substantially neutrally buoyant underwater deployable
14 device such as an acoustic countermeasure device or an
15 oceanographic sensor device. Further, the deployable devices
16 may be deployed individually or as a field due. The
17 displacement device requires less weight and weight within an
18 overall deployed device, enabling large deployments and
19 performance enhancements.

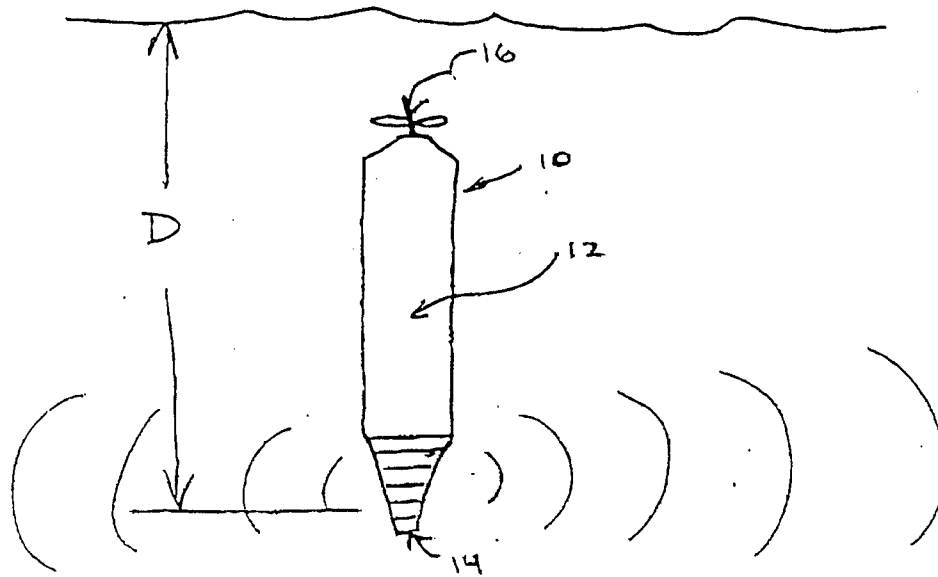

FIG. 1 (PRIOR ART)

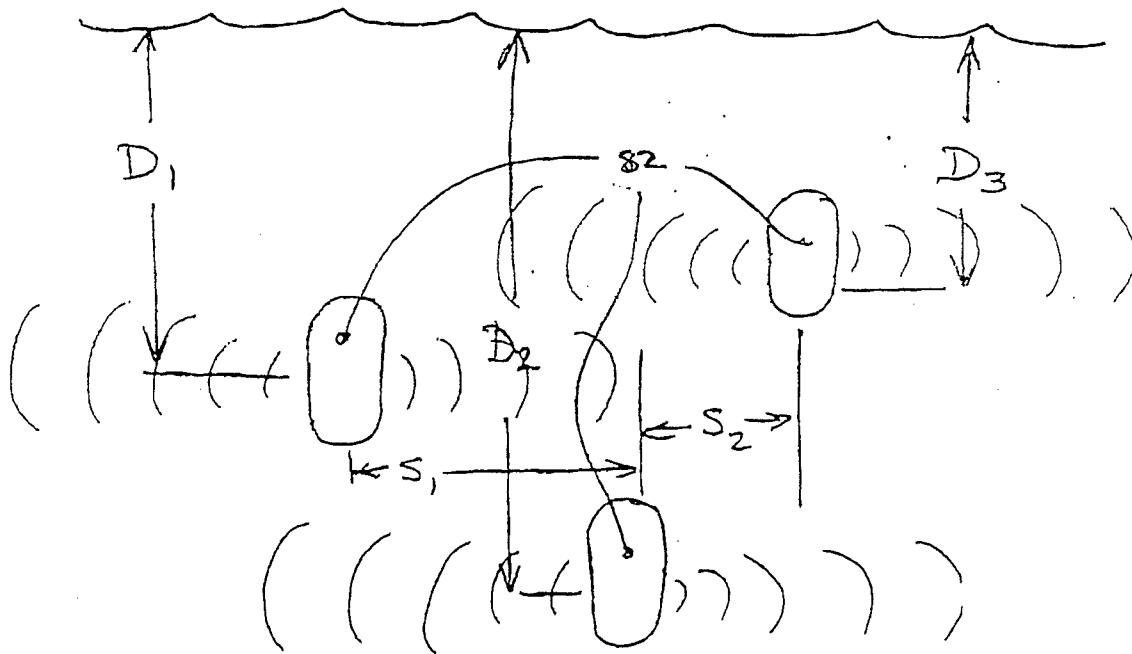

FIG. 6

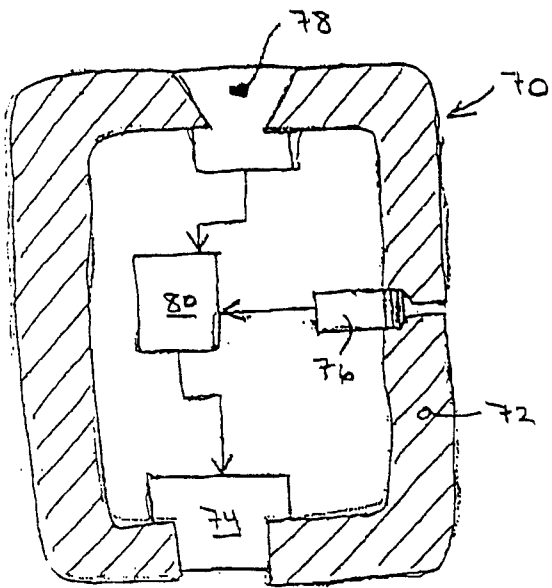

FIG. 4

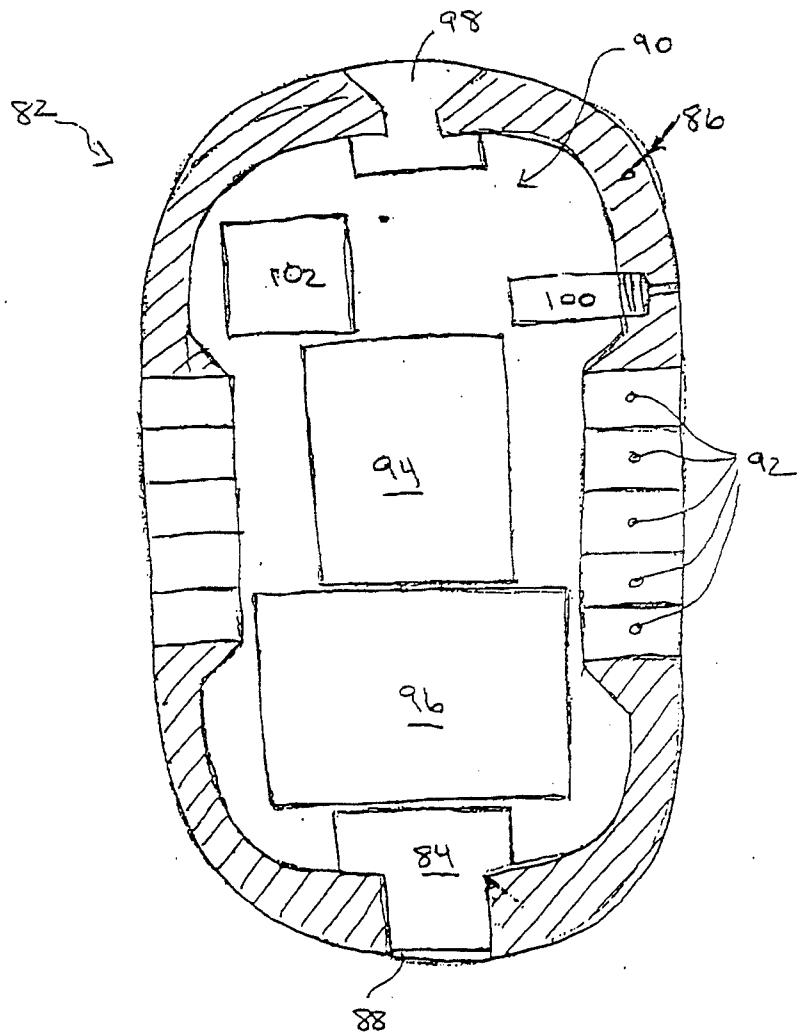

FIG. 5

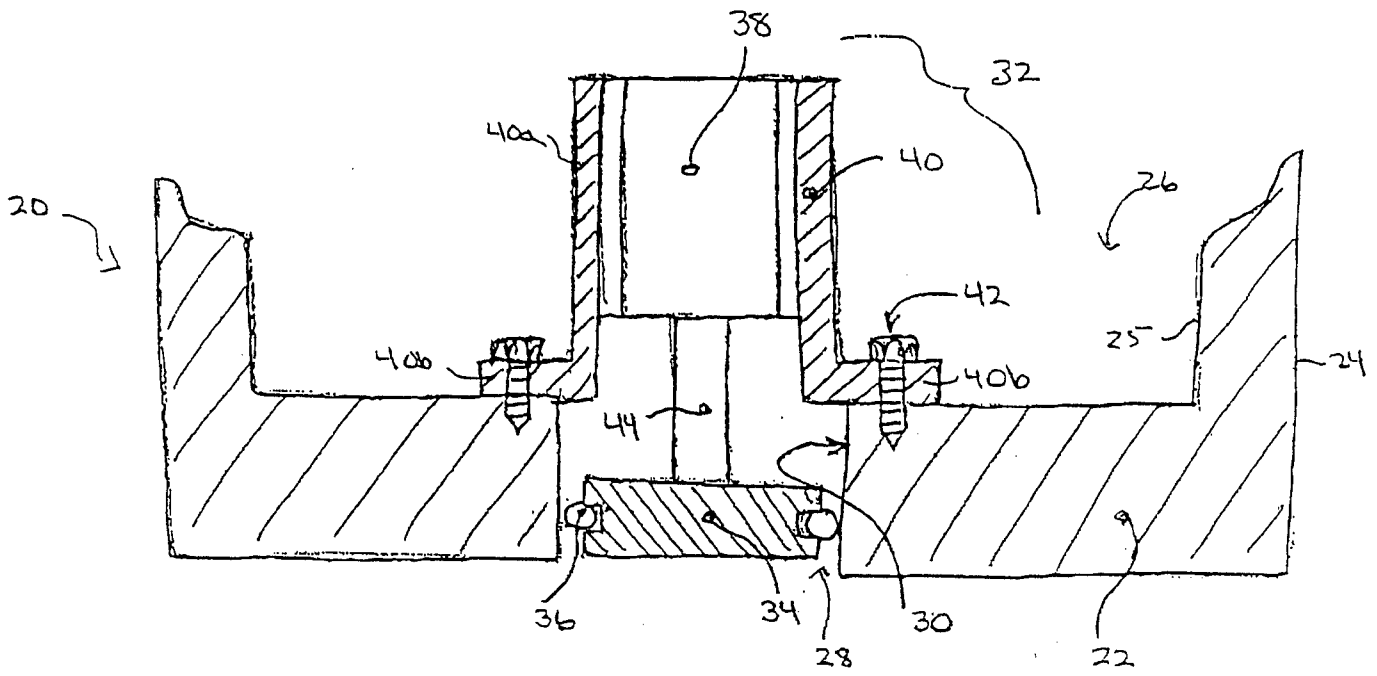

FIG. 2

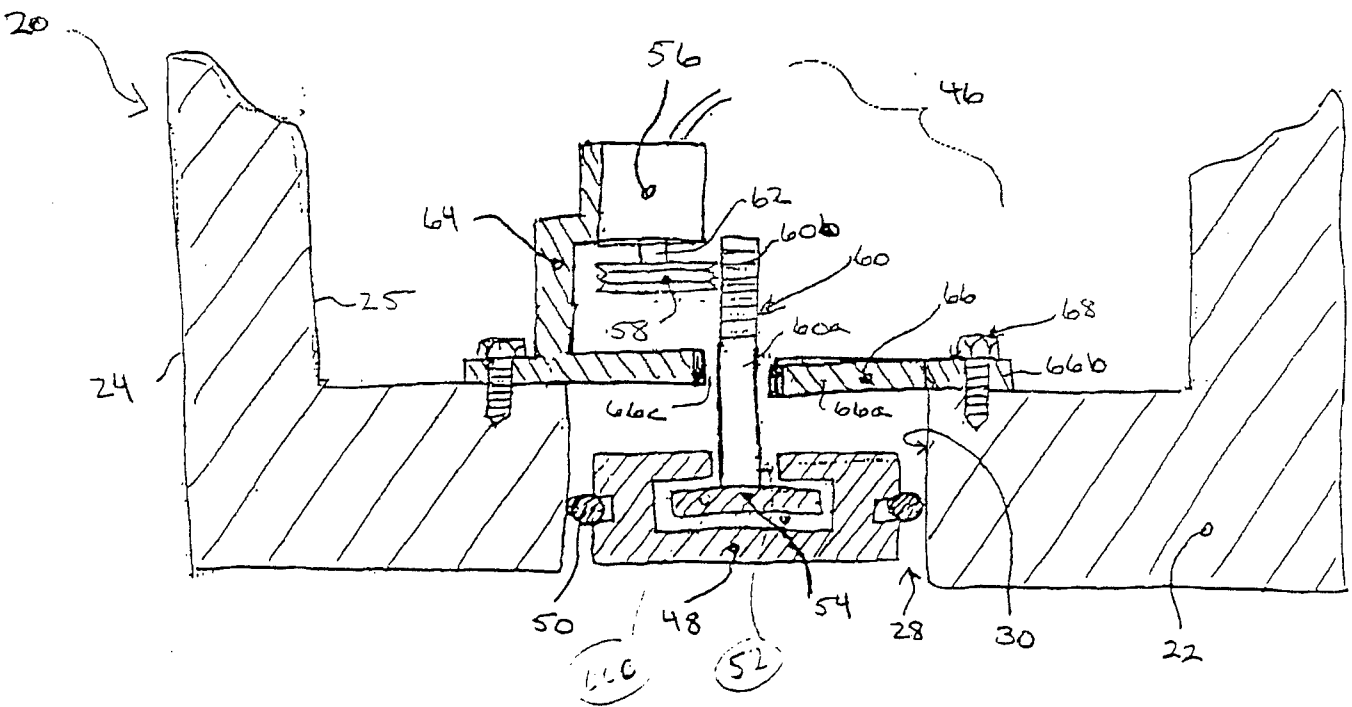

FIG. 3