

Serial Number 09/922,307
Filing Date 1 August 2001
Inventor Eugene P. Rivers, Jr.

NOTICE

The above identified patent application is available for licensing. Requests for information should be addressed to:

OFFICE OF NAVAL RESEARCH
DEPARTMENT OF THE NAVY
CODE 00CC
ARLINGTON VA 22217-5660

DISTRIBUTION STATEMENT A
Approved for Public Release
Distribution Unlimited

20010921 113

5 PAYLOAD DISPENSING SYSTEM PARTICULARLY SUITED FOR
UNMANNED AERIAL VEHICLES

STATEMENT OF GOVERNMENT INTEREST

10 The invention described herein may be manufactured and
used by or for the Government of the United States of
America for governmental purposes without any payment of
any royalty thereon or therefor.

15 BACKGROUND OF THE INVENTION

1.0 Field of the Invention

The present invention relates to dispensing systems
and, more particularly, to payload dispensing systems
20 particularly suited for use on unmanned aerial vehicles.

2.0 Description of the Related Art

Unmanned aerial vehicles, which includes drones, are
pilot-less airplanes controlled from a ground station by
25 the use of RF signals. Unmanned aerial vehicles (UAVs)
have many usage's, one of which may be the accurate
delivery of a payload to a designated site, such as a
target of interest.

The accuracy of the delivery of the payload is dependent upon the accuracy at which the payload is dispensed from the UAVs to the target of interest. It is
5 desired that a payload dispensing system be provided that is particularly suited to the mounted on an unmanned aerial vehicle and that allows the payload to be accurately dispensed from the unmanned aerial vehicle.

10

OBJECTS OF THE INVENTION

It is a primary object of the present invention to provide a payload dispensing system that accurately dispenses the contents of its payload and that is
15 particularly suited to be mounted on an unmanned aerial vehicle.

It is another object of the present invention to provide for a payload dispensing system that accepts
20 atmospheric data so as to further improve the accuracy at which the payload dispensing system dispenses the contents of its payload.

Another object of the present invention is to provide a payload dispensing system and a method of operation thereof is easily integrated into unmanned vehicles.

5

SUMMARY OF THE INVENTION

This invention is directed to a payload dispensing system particularly suited for being mounted on an unmanned aerial vehicle that communicates with a ground control system. The payload dispensing system comprises a receiver, a transmitter, an autopilot, and a payload dispenser. The receiver receives information from the ground station and provides corresponding output signals. The transmitter transmits information to the ground station and to the autopilot. The autopilot responds to the output signals of the receiver and provides corresponding output signals to the transmitter. The payload dispenser comprises a computer, a magazine, and a controller. The computer at least one input port for receiving the output signals from the receiver and at least one output port. The magazine holds the payload comprising a plurality of tubes, each containing a capsule and each having a cartridge actuating device responsive to an electrical signal. The controller is connected to the at least one

10

15

20

output port so as to receive information from the computer and generates corresponding output signals therefrom. The controller has electrical means for being connected to each of the cartridge actuating devices. The controller
5 responds to the information from the computer and generates respective electrical signals to the cartridge actuating devices causing respective capsules to be ejected from the respective tube.

10

BRIEF DESCRIPTION OF THE DRAWINGS

A better understanding of the present invention may be realized when considered in view of the following detailed description, taken in conjunction with the accompanying
15 drawings.

Fig. 1 is a simplified drawing of an unmanned aerial vehicle that houses the payload dispensing system of the present invention.

20

Fig. 2 is a block diagram of one embodiment of the payload dispensing system of the present invention.

Fig. 3 illustrates one embodiment of a payload dispenser of the present invention.

Fig. 4 illustrates another embodiment of the payload dispenser of the present invention.

Fig. 5 illustrates a magazine section that is part of the payload dispenser of the present invention.

Fig. 6 illustrates one tube of the payload dispenser of the present invention.

Fig. 7 illustrates another embodiment of the payload dispensing system of the present invention.

Fig. 8 illustrates a further embodiment of the payload dispensing system of the present invention.

DETAILED DESCRIPTION OF THE PREFERRED EMBODIMENTS

Referring to the drawings, wherein the same reference number indicates the same element throughout, there is shown in Fig. 1 a payload dispensing system 10 that is mounted in a unmanned aerial vehicle 12 shown in a

simplified manner. The unmanned aerial vehicle 12 comprises a payload bay 14, a spar box 16, an avionics bay 18, a bomb bay 20, having an opening 22.

5 In general, the unmanned aerial vehicle 12 conveys the payload dispensing system 10 to a designated site, such as a target of interest, wherein the payload of the payload dispensing system is released upon command from a ground control station so that the contents of the payload fall
10 from the unmanned aerial vehicle 12 under the influence of gravity. The payload dispensing system 10 provides for the accurate release of the contents of the payload from the unmanned aerial vehicle 12 all of which may be further described with reference to Fig. 2.

15

The unmanned aerial vehicle 12, which carries the payload dispensing system 10 is controlled by a ground station 24 having transmitting and receiving elements 24A and 24B respectively. In some embodiments, the unmanned
20 aerial vehicle 12 is also controlled from inputs from a forward spotter 26 that routes the related information to the ground control station 24. The ground control station 24 may also receive, via the signal path 24C, information from an associated external transmitter 28.

The payload dispensing system 10 comprises a receiver 30, having a receiving element 32, that receives a RF signal from the ground control station 24 by way of RF link 34. The payload dispensing system 10 further comprises a transmitter 36 that transmits information, via its transmitting element 38, to the ground control station 24, via element 24B and RF link 40. The payload dispensing system 10 still further comprises an autopilot 42 which receives information from the receiver 30, by way of signal path 44A, and transmits corresponding output signals to transmitter 36, by way of signal path 44B.

The payload dispensing system 10 preferably further comprises first and second video cameras 46 and 48 that respectively provides their output signals, via signal paths 50 and 52, to a video switcher 54. The video switcher 54 transmits information on signal path 56 to transmitter 36 and receives information on signal path 58 from receiver 30.

20

The first camera 46 is preferably mounted on the front end of the unmanned aerial vehicle 12 and serves as a forward video camera, whereas the second video camera 48 is preferably mounted on the unmanned aerial vehicle 12 so as

to view downward therefrom and serves as a down-look video camera. The second video camera 48 is used by a system operator utilizing the ground control station 24, as a visual cue for determining when to release the payload
5 contained in a payload dispensing system 10. The video switcher 54 allows the system operator to switch between the forward camera 46, the down-look video camera 48, or a picture-in-a-picture view of both cameras 46 and 48. The payload dispensing system 10 further comprises a payload
10 dispenser 60 that receives information, via signal path 62, from the receiver 30 and may be further described with reference to Fig. 3.

Fig. 3 illustrates the payload dispenser 60 as
15 comprising a computer 64, a controller 66, and a magazine 68. The computer may be a PC104 computer which is known in the art and comprises modular computer components based on Intel processors. The computer 64 has a plurality of input ports, one of which receives output signals from the
20 receiver 30, via signal path 62. The computer 64 further comprises a plurality of output ports one of which is routed to controller 66, via signal path 70.

The controller 66 receives information from the computer and generates corresponding output signals therefrom.

5 The logic controller 66, in response to the information on signal path 70, operates to send firing pulses to the magazine 68 by way of signal path 72. A further embodiment of a payload dispensing system 60A may be further described with reference to Fig. 4.

10

The payload dispensing system 60A, in addition to elements of the payload dispensing system 60 of Fig. 3, further comprises the differential GPS receiver 74 having an element 74A that receives information from an external
15 source by way of RF link 76. The payload dispensing system 60A further comprises a first data link 78 that receives, via element 78A, atmospheric data 88 derived from a sensor 82. The data link 78 routes its output signals to the computer 64 by way of signal path 84.

20

The payload dispensing system 68 further preferably comprises a data link 86 that receives information from the receiver 30 by way of signal path 62 and routes the

received information to the computer 64 by way of bilateral data path 88.

The GPS receiver 74 is made available by Omni Star and provides precise air vehicle latitude, longitude, altitude, and velocity information to the computer. The computer 64 provides on-board processing to control the differential GPS receiver 74. The data link 78 receives atmospheric data that is provided by sensor 82 which is commonly referred to as a T-drop dispenser and which is routed to computer 64. The T-drop data is also routed back to the ground station 24, by way of computer 64, data link 86, receiver 30, and transmitter 36. The ground station 24 utilizes the T-drop data to compute atmospheric conditions, including wind speed and direction from the drop altitude of the unmanned aerial vehicle 12 to the ground.

The data link 86 serves as an interface for the computer 64 to communicate to the ground station 24 and allows the ground station 24 to enter target coordinates, and the payload ballistic trajectory model to predict down-range and cross-range travel for the payload contents. The target coordinates and the predicted down-range and cross-range data are sent to the computer 64.

The computer 64 calculates steering commands and time-to-go until the payload release using the information from the on-board differential GPS receiver 74 and sends this data to the ground station 24. The ground station 24, via
5 computer 64, provides a consent-to-fire command when ready and the computer 64, via the controller 66 causes the payload to be dispensed when the on unmanned aerial vehicle 12 reaches the predetermined release coordinates. The controller 66 provides the command signals to a magazine
10 68, shown in Figs. 3 and 4, and which may be further described with reference to Figs. 5 and 6.

The magazine 68 comprises a rack 90 in which is logged a plurality of tubes $92_1 \dots 92_N$ as shown in Fig. 5. Fig. 5
15 also illustrates two of the tubes $92_1 \dots 92_N$ as being removed, so as to expose the housing of a cartridge actuating device 94. Each of the tubes $92_1 \dots 92_N$ has a cartridge actuating device 94. Each of the cartridge actuating devices 94 is responsive to a respective electrical signal which causes
20 the capsules contained in the tubes $92_1 \dots 92_N$ to be ejected from the respective tube $92_1 \dots 92_N$. The interconnection between the cartridge actuating devices 94 and the controller 66 is provided by a breech plate 98 having an

appropriate wiring harness 100 comprised of multiple paths
102₁, 102₂,... 102_N.

Fig. 5 does not illustrate the capsules that are
5 lodged within the tubes 92₁...92_N, but are shown Fig. 6.

Fig. 6 illustrates a capsule 104 comprised of cylinder
106 having opposite ends, with a cartridge actuating device
94 at one end and a releasable cap 108, preferably
10 comprised of plastic at the other end. The capsules 104
are placed in the tubes 92₁...92_N, in the magazine section 68.
The magazine section 68 is preferably mounted in the bomb
bay 20 of the unmanned aerial vehicle 12 so that the tubes
92₁...92_N are exposed in the opening 22 of the bomb bay 20 and
15 so that the capsules 104 are ejected from the unmanned
aerial vehicle 12 when the controller 66 delivers the
electrical signals to the respective cartridge actuating
device 94.

20 It should now be appreciated that the practice of
the present invention provides for a payload dispensing
system 10 that releases the contents of the payload in
response to commands initiated from a ground control system

that are accurately delivered to the controller 66 by the computer 64.

A further embodiment of the present invention may be further described with reference to Fig. 7. The embodiment of the Fig. 7 illustrates the utilization of wind data 110 that is routed to a ballistic trajectory model 112, via signal path 114, whereas operating parameters of the ballistic trajectory model 112 are routed to the ground control station 24, via signal path 116. The wind data 110 and the ballistic trajectory model 112 are utilized by the operating program within the ground station 24 to develop the prediction of coordinates for dispensing the payload in order to more accurately designate a point on the ground for the delivery of the payload by the payload dispensing system 10. The operating program includes a simple three (3)-degree of freedom model, utilizing the ballistic trajectory model 112 to predict the coordinates at which to dispense the payload based upon atmospheric conditions, and unmanned aerial vehicle 12 velocity, heading, and altitude. The operating program within the ground control station 24 also calculates the depression angle for a video camera, such as the second video camera 48 of Fig. 1 which is included as part of the

video reconnaissance payload 118 shown in Fig. 7. The depression angle information is routed to the video reconnaissance payload 118 by way of transmitter element 24D, RF link 24E, and receiver element 120A of video data link 120. The video data link 120 communicates with the video reconnaissance payload 118 by way of bilateral signal path 122. The video data link 120 also communicates with the computer 64 by way of bilateral signal path 126.

10 A further embodiment of the present invention may be further described with reference to Fig. 8.

Fig. 8 illustrates an embodiment 128 that includes the elements 118 and 120 of Fig. 7, as well as the autopilot 42 of Fig. 1. The embodiment 128 further includes a GPS receiver 130 that supplies location information, via signal path 132 to the autopilot 42. The embodiment 128 further includes the data link 134 that supplies information to the autopilot 42 by way of signal path 136. The data link 134 operatively cooperates with a receiver element 134A that receives information from the transmitting element 24A of the ground control system 24 by way of RF link 136.

The embodiment 128 further comprises the utilization of payload control information 138 which is routed to the ground control station 24 by way of signal path 140. The ground control station 24, in a manner similar to that described with reference to Fig. 7, has an operating program that provides for payload ballistic trajectory model, but having a more accurate 6-degree-of-freedom payload ballistic trajectory model which, in turn, improves the accuracy of the payload dispensing system 10 which, in turn, allows for the payload carried by the unmanned aerial vehicle 12 to be more accurately delivered to its target of interest.

It should now be appreciated that the practice of the present invention provides for various embodiments each allowing for the accurate release of the contents of the payload being carried by the unmanned aerial vehicle 12.

While the invention has been described with reference to the specific embodiments, this description is illustrative and is not to be construed as limited in scope of the invention. Various modifications will occur to those skilled in the art without departing from the spirit and scope of the invention.

ABSTRACT OF DISCLOSURE

A payload dispensing system and a method of operation thereof are disclosed that comprises an on-board computer, a magazine, and a controller all of which operatively cooperate so that cartridge actuating devices may be selectively activated so that the contents of the payload being carried by an unmanned aerial vehicle can be accurately delivered to a target of interest.

10

DOCKET: NAVY CASE 82210

INVENTOR: EUGENE P. RIVKIN, JR

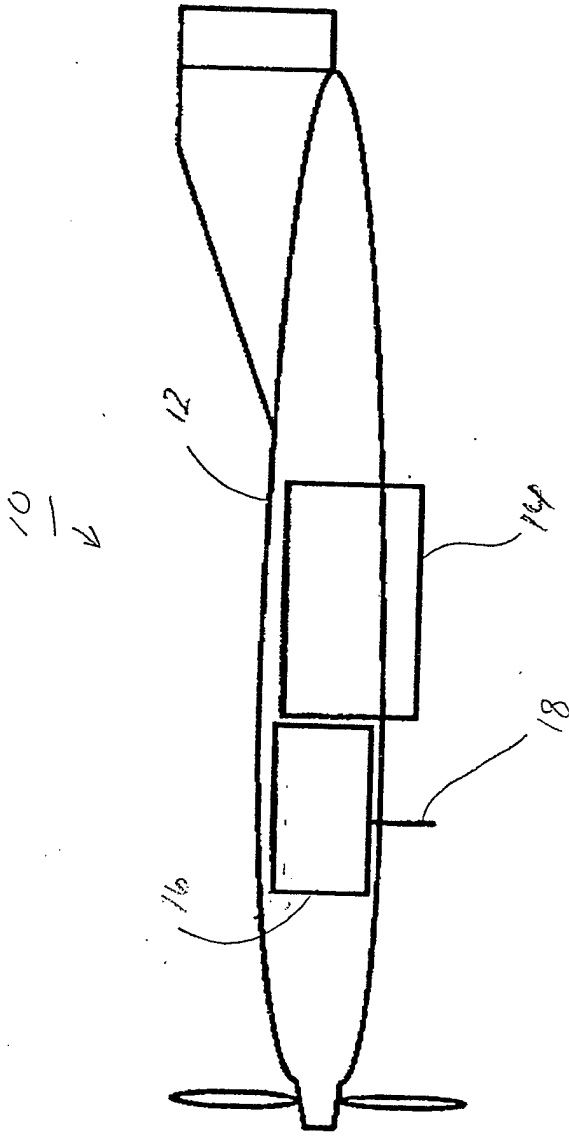

FIG. 1

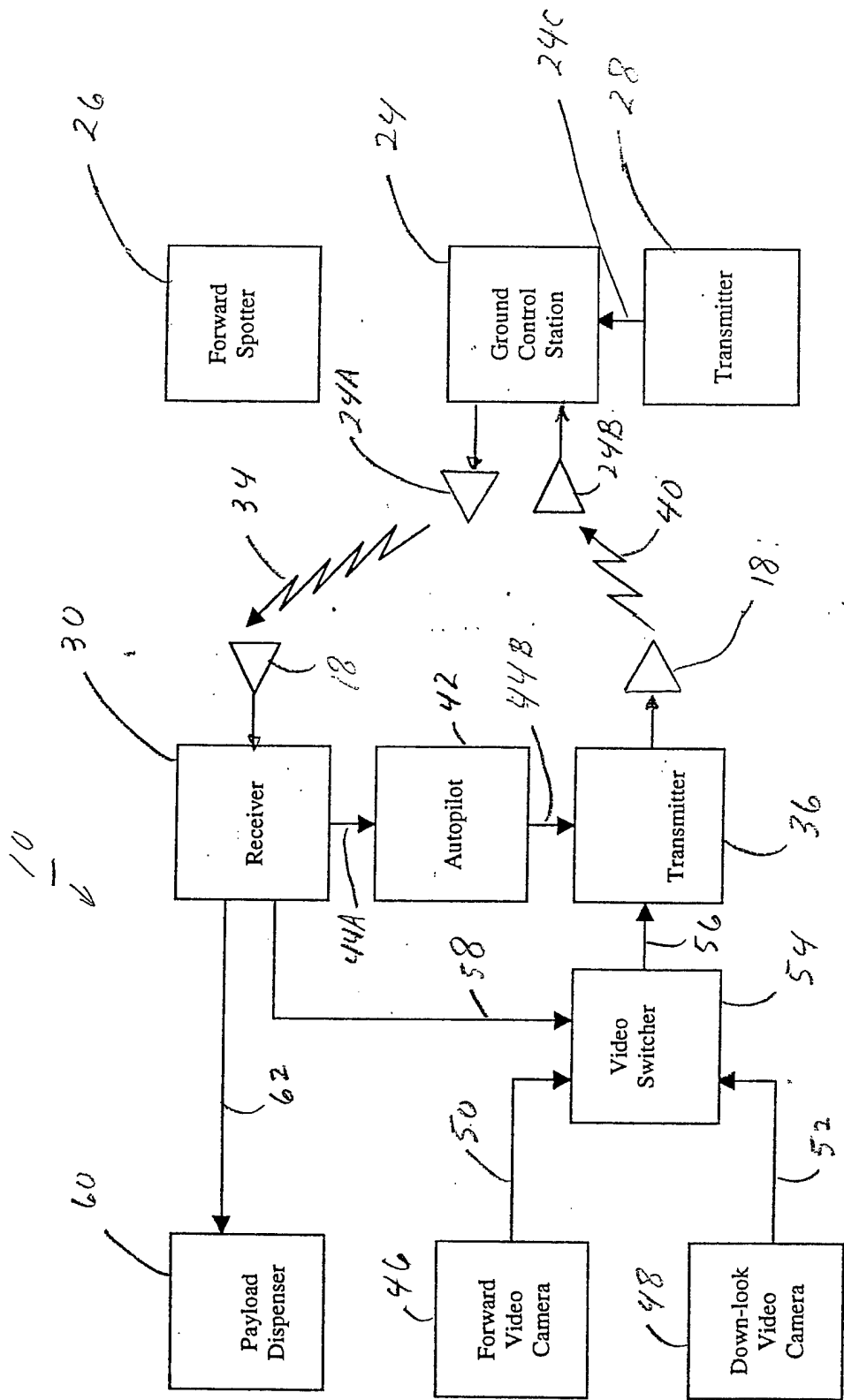
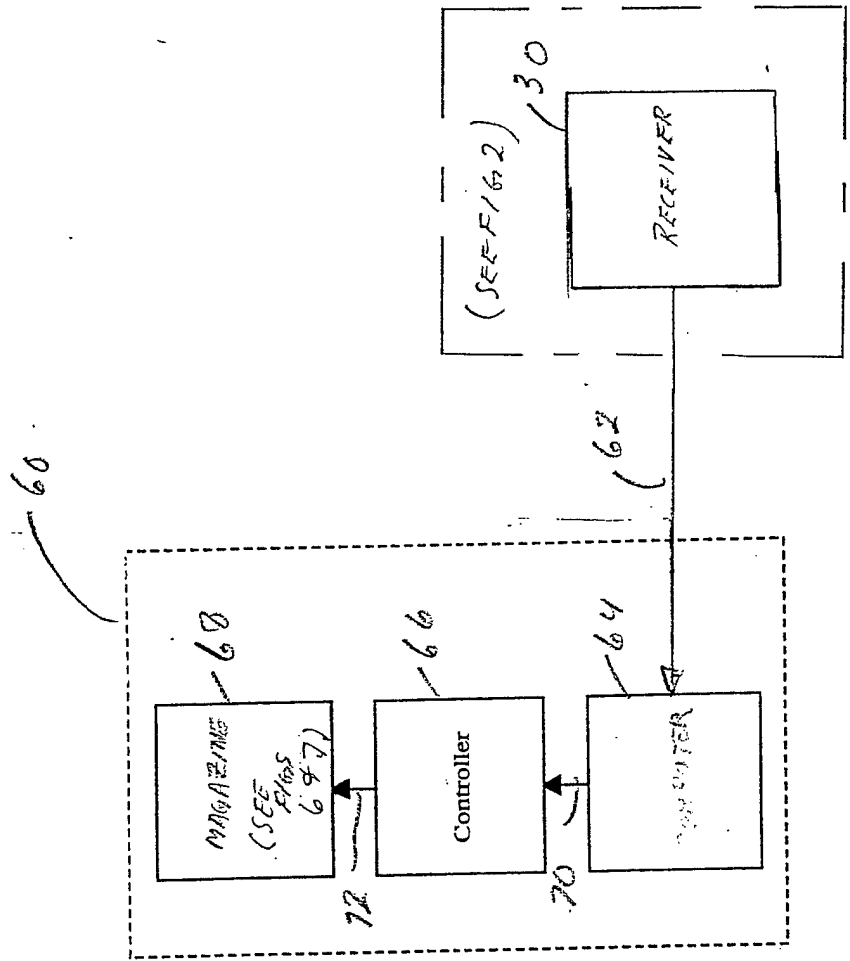

FIG. 2

Docket # 100-100000



F1693

82210

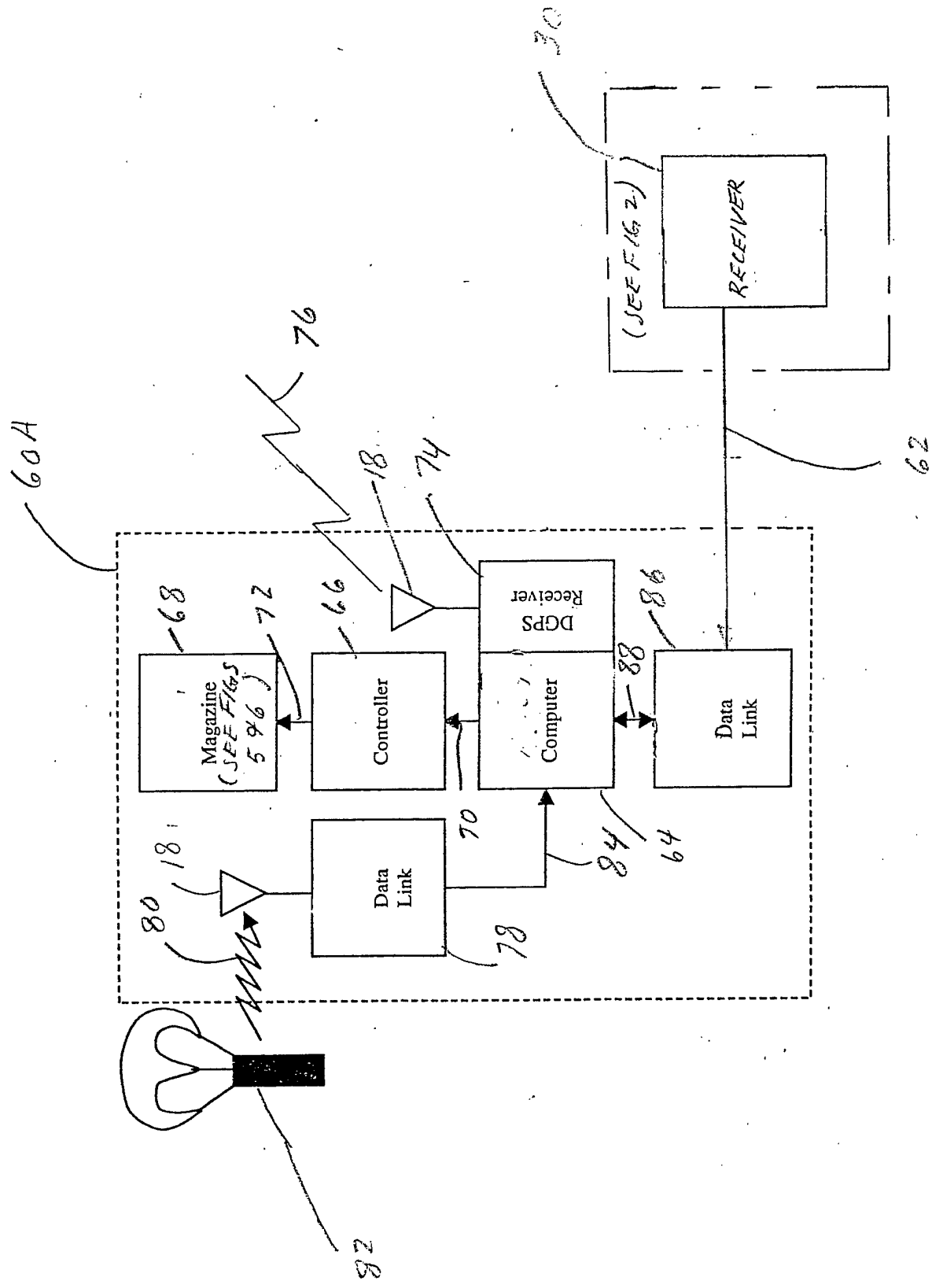

FIG 4

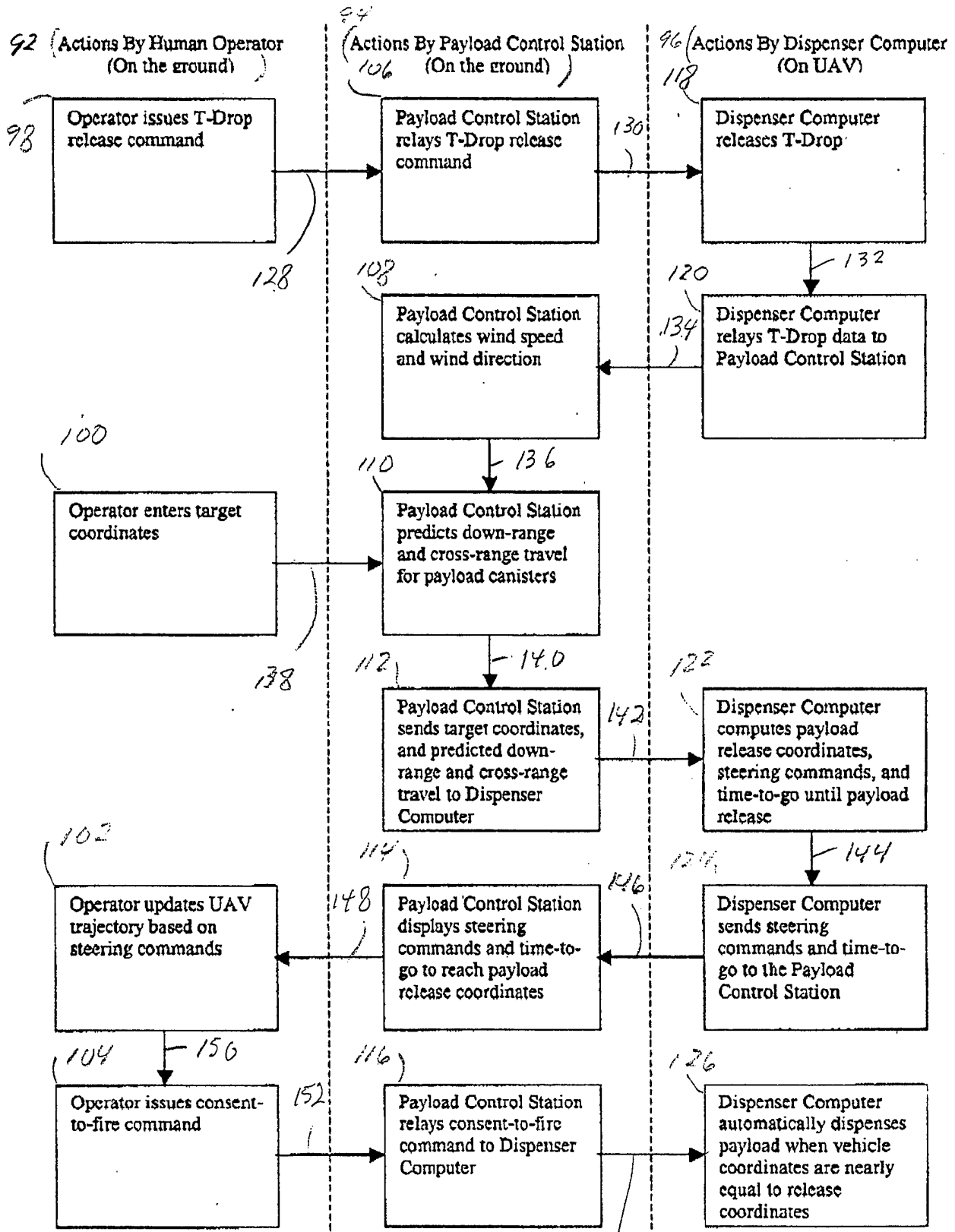

Fig 5

BUCKET; NAVY CASE 82210

68
↓

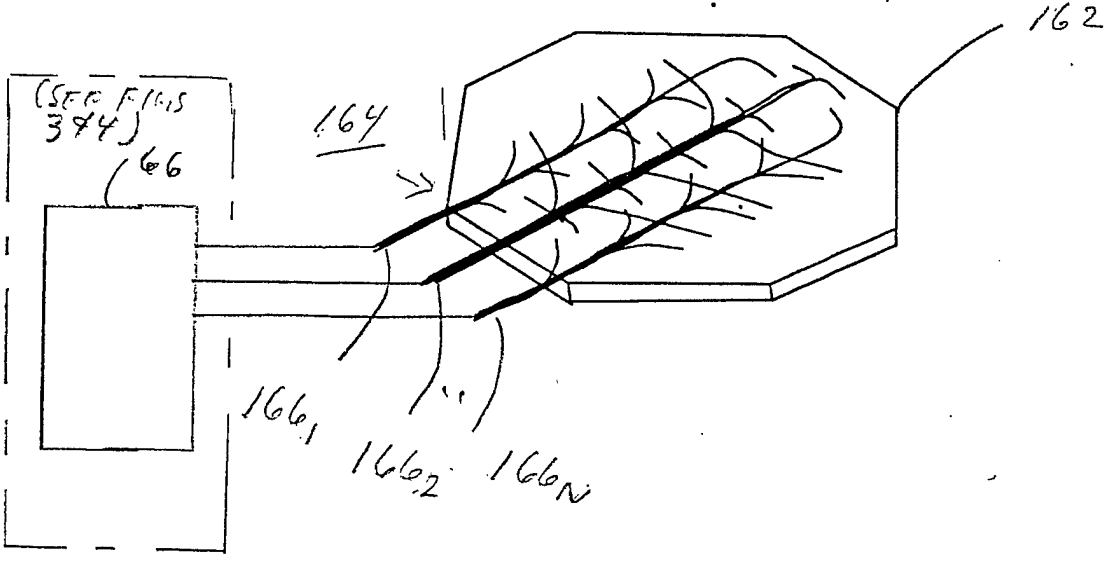
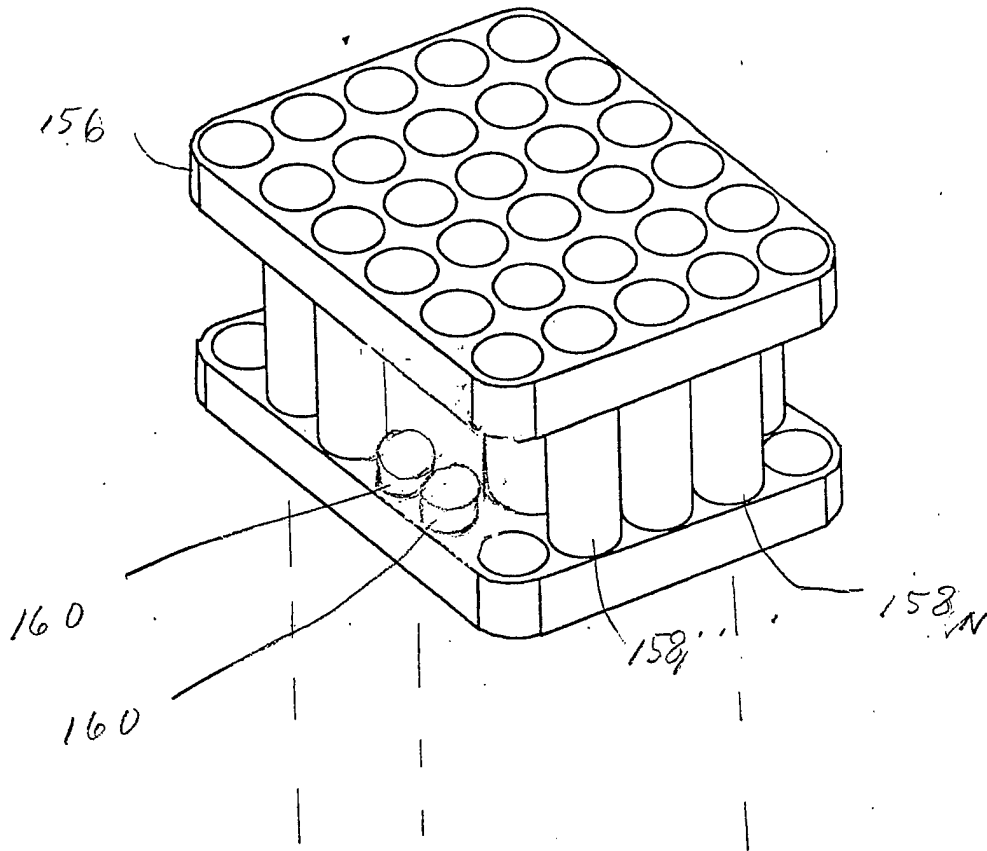

FIG 6

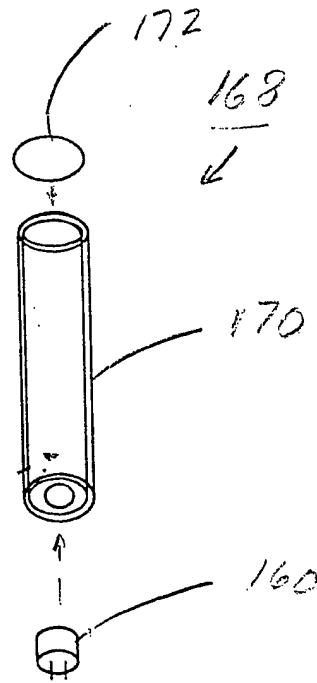

FIG 7

DAVIDSON AVIATION CORP 52210

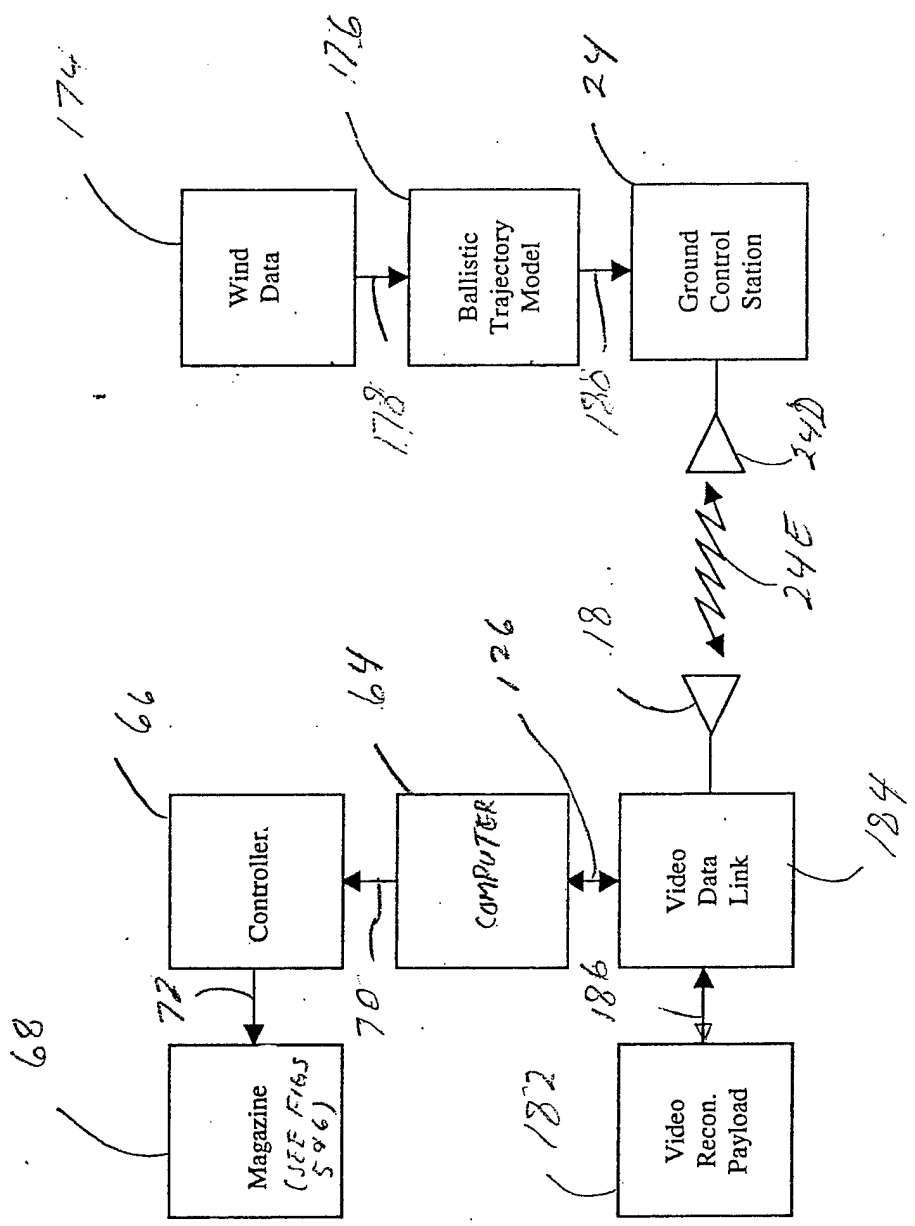

FIG 8

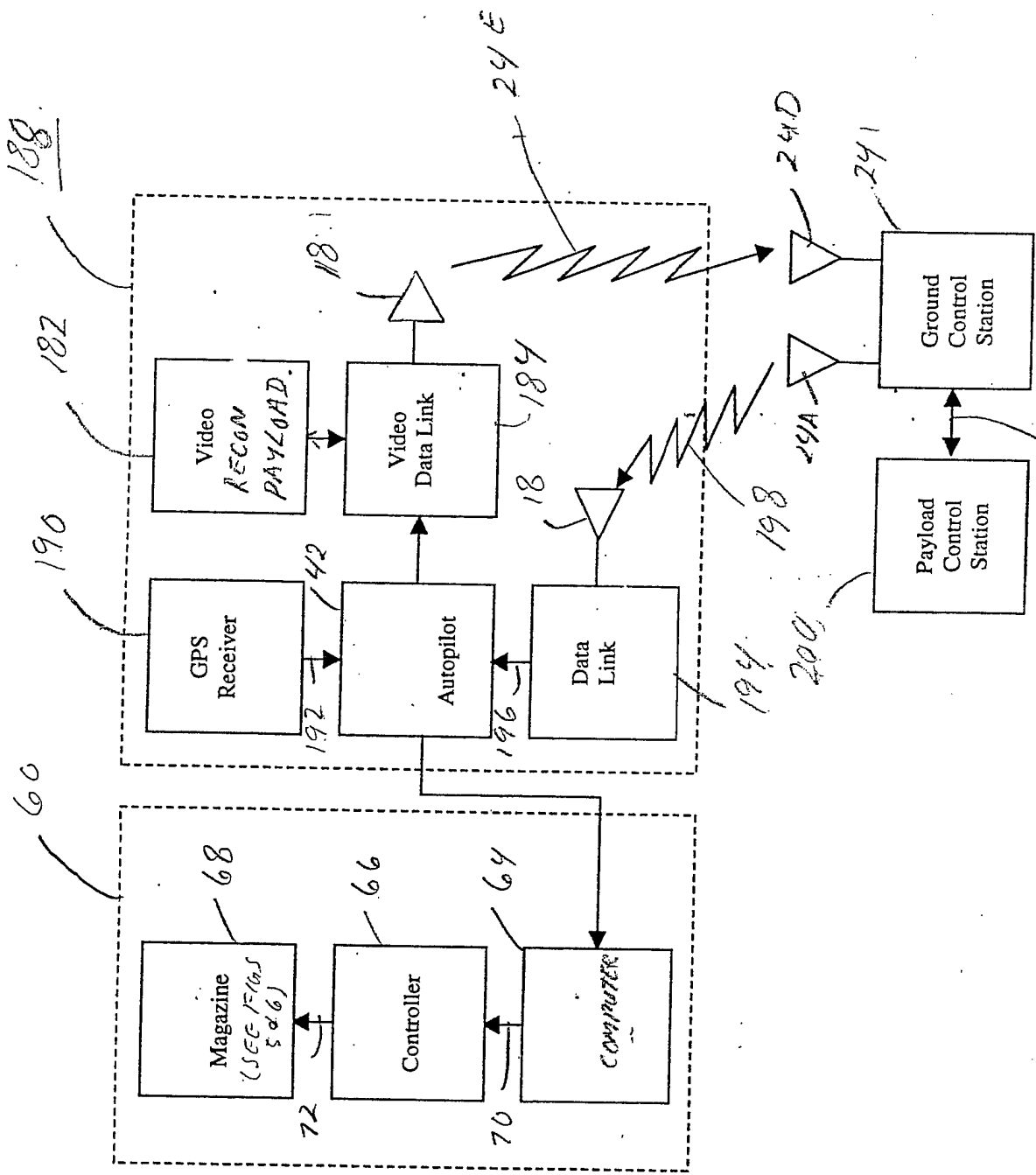

FIG 9