

Serial No.: 09/876,137

Filing Date: 08 June 2001

Inventor: John A. Pavco

NOTICE

The above identified patent application is available for licensing.
Requests for information should be addressed to:

ASSOCIATE COUNSEL (PATENTS)
CODE 1008.2
NAVAL RESEARCH LABORATORY
WASHINGTON DC 20375

20010730 112

PATENT APPLICATION/TECHNICAL DIGEST PUBLICATION RELEASE REQUEST

FROM: Associate Counsel (Patents) (1008.2)
TO: Associate Counsel (Patents) (1008.2)

Via: (1) John A. Pavco (Code 5305)
(2) Division Superintendent (Code 5300)
(3) Head, Classification Management & Control (Code 1221)

SUBJ: Patent Application/Technical Digest entitled: **"THREE-DIMENSIONAL SYNTHETIC APERTURE RADAR FOR MINE DETECTION AND OTHER USES"** request for release for publication.

REF: (a) NRL Instruction 5510.40C
(b) Chapter 6, ONRINST 5870.1C

ENCL: (1) Copy of patent Application/Technical Digest

1. In accordance with the provision of references (a) and (b), it is hereby requested that the subject Patent Application/Technical Digest be released for publication.

2. It is intended to offer this Patent Application/Technical Digest to the National Technical Information Service, for publication.

3. This request is in connection with Navy Case No. 77,119

6/14/01
(date)



JOHN J. KARASEK
Associate Counsel (Patents)

FIRST ENDORSEMENT

Date: June 29, 2001

FROM: John A. Pavco (Code 5305)
TO: Division Superintendent (Code 5300)

1. It is the opinion of the Inventor(s) that the subject Patent Application/Technical Digest ~~(is)~~ (is not) classified and there is no objection to public release.



Inventor's Signature

SECOND ENDORSEMENT

Date: 6/29/01

FROM: Division Superintendent (Code 5300)
TO: Classification Management & Control (Code 1221)

1. Release of Patent Application/Technical Digest (is) (~~is not~~) approved.
2. To the best knowledge of this Division, the subject matter of this Patent Application/Technical Digest (~~has~~) (has not) been classified.
3. This recommendation takes into account military security, sponsor requirements and other administration considerations and there in no objection to public release.



Division Superintendent

THIRD ENDORSEMENT

Date:

FROM: Head, Classification & Control (Code 1221)
TO: Associate Counsel (Patents) (1008.2)

1. This Patent Application/Technical Digest is authorized for public release.

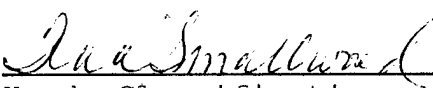

Head, Classification, Management & Control

THREE-DIMENSIONAL SYNTHETIC APERTURE RADAR
FOR MINE DETECTION AND OTHER USES

BACKGROUND OF THE INVENTION

1. Field of the Invention

[0001] The present invention relates to a system and method for detecting objects under the surface of the ground, and in particular, to three-dimensional imaging to detect an underground target item such as a mine.

2. Background of the Invention

[0002] Buried mines on, e.g., a beachhead, are a major threat to amphibious landing forces and a severe obstacle to a rapid amphibious landing. Clearing mines prior to a full-scale landing is a slow and tedious process that requires manual location and neutralization of the individual mines. This process includes the use of heavy machinery to detonate anti-personnel mines while, at the same time, facing the threat of larger anti-tank mines.

[0003] Ground penetration radar systems using transistor generated short pulses have been in use for decades for geophysical applications. These systems can be relatively compact, approximately the size of a lawn mower, and are generally pulled along the ground with the radar signal directed downwardly into the ground.

[0004] Recently, airborne (e.g., from an aircraft) synthetic aperture radar (SAR) has also been used in mine detection. SARs typically are side-looking radar which produce a two-dimensional image of the earth's surface. In the past, SARs operated with bandwidth up to 500 MHz 1 GHz resulting in range resolution of 6 inches.

[0005] In addition to aircraft-based radar systems, ground-based two-dimensional SAR imaging systems have been used to locate buried mines. These ground-based SAR systems use an impulse radar disposed on an elevated platform and operated in a side-looking mode.

[0006] One disadvantage with current radar-based mine detecting systems is that these systems tend to be limited to generating only a two-dimensional image rather than a three-dimensional image. A two-dimensional imaging system has limited capabilities with respect to the accuracy and precision by which the mine detection system operates when compared with that potentially available with three-dimensional imaging system.

[0007] An additional disadvantage with current SAR systems is that these systems produce an image of limited resolution. Since SARs have operated at bandwidths up to 16 Hz, SAR range resolution is limited to about six inches, as indicated above. Consequently, the six-inch imaging resolution reduces the applicability of SARs in buried mine imaging, detection and classification because mines tend to be 3 inches to a foot in diameter.

BRIEF SUMMARY OF THE INVENTION

[0008] In accordance with the present invention, an aerielly disposed three-dimensional SAR system is provided which enables subsurface (i.e., underground) object detection. Such objects include, but are not limited to, mines. The three-dimensional SAR includes a radar transmitter and an array of receiving antennas which are aerielly translatabe, i.e., which are mounted on an aircraft so as to be transported

with the aircraft. Three-dimensional SAR imaging is obtained from a reflected radar signal detected by the antenna array as the array traverses over a target area.

[0009] According to one aspect of the invention, a radar system includes an aircraft for detecting buried objects from the air, for overflying a target area of interest, a radar transmitter, carried by the aircraft, for producing a radar signal of a frequency or at least three gigahertz, a plurality of radar receiving antennas, carried by the aircraft and forming an antenna array, for receiving a reflected signal produced by reflection of said radar signal, and a processor for generating a three-dimensional image of said object from the reflected signal.

[0010] According to another aspect of the invention, a method is provided for detecting a subsurface object in a target area from an aircraft. The method includes transmitting a pulsed radar signal having a frequency of at least three gigahertz using a radar transmitter dispersed on the aircraft, receiving a return of the transmitted signal reflected by the subsurface object with a plurality of radar receiving antennas disposed on the aircraft and forming a receiving antenna array, and generating a three-dimensional image based on the received return of the transmitted signal.

[0011] An advantage of the present invention concerns the use of an aerial translatable three-dimensional synthetic aperture radar for the detection of buried objects such as mines.

[0012] An additional advantage of the present invention concerns enhanced image resolution compared with conventional SAR systems by implementing SAR using a radar signal having a frequency of at least three gigahertz.

[0013] Yet another advantage of the present invention concerns the use of various types of wide band radar signals such as impulse radar signals and frequency-stepped pulse compression radar signals.

[0014] Further features and advantages of the present invention will be set forth in, or apparent from, the detailed description of preferred embodiments thereof which follows.

BRIEF DESCRIPTION OF THE DRAWING

[0015] Figure 1(a) is an elevational view of an aircraft-mounted radar system according to a preferred embodiment of the present invention, with the aircraft shown in a tilted position for illustrative purposes;

[0016] Figure 1(b) is a perspective view of the radar system of Figure 1(a); and

[0017] Figure 2 is a schematic diagram, partially in block form, of the basic operation of the system of the invention.

DETAILED DESCRIPTION OF THE INVENTION

[0018] Referring now to the drawings, and in particular to Figures 1(a) and 1(b), illustratively depicted therein is radar system 10 according to the present invention. Radar system 10 includes radar transmitter 12 which generates radar signal 14 of at least three gigahertz, corresponding to the S-band and X-band carrier frequencies. Preferably, the frequency is within the range of three to ten gigahertz to provide good resolution with acceptable signal attenuation. However, higher frequencies can be used to provide enhanced resolution where signal attenuation is accommodated.

[0019] The radar signal 14 is directed towards the surface 16 of the underlying ground 18 of a target area denoted 19. Radar signal 14 penetrates surface 16 and reflected signals 22 are produced by the radar signal 14 reflecting off of the surface of buried objects indicated at 20.

[0020] An antenna array 24 is formed of a plurality of receiving antennas 26 which receive reflected signal 22. Receiving antennas 26 are disposed along wings 28 of an aircraft 30. The real aperture, a_r of antenna array 24 is defined by the diameter of the individual receiving antennas 26. A horizontal aperture for the radar system 10 is defined by the width D of the antenna array 24. The height of the aircraft 30 is indicated as h .

[0021] To enhance the horizontal aperture of the radar system, some of the receiving antenna 26 are located on extendible booms 32 located at the opposite ends of wings 28. As will be obvious to one of ordinary skill in the art, the lengths of the booms 32 may be extended or varied in order to produce larger or variable horizontal apertures as necessary.

[0022] To further aid in an understanding of the implementation of radar system 10, Figure 2 provides a block diagram which schematically depicts the operation of radar system 10. As described above, during the operation thereof, radar transmitter 12 generates and directs radar signal 14 toward the surface 16 of ground area 18. The radar signal 14 is reflected off of the surface of a buried object 20 thereby forming reflected signal 22. A portion of reflected signal 22 is received by the antenna array 24.

[0023] When radar system 10 is deployed in mine detection, carrier frequencies above L-band yield depth penetration beneath the surface 16 while also providing

attenuation of backscattering from material at depths greater than typical, standard mine deployment. Three-dimensional SAR imaging is achieved from radar system 10 by aerially traversing target area 19 while transmitting a radar signal 14 thereto and receiving a reflected signal 22 therefrom by means of receiving array 24.

[0024] Three-dimensional images may be generated from radar system 10 of varying resolution based on radar frequency, along track real receiver aperture dimension (a) cross track array aperture, and altitude h of aircraft 30. More specifically, three-dimensional imaging is obtained from reflected signal 22 from range resolution, along-track resolution, and cross-track resolution. The range resolution is obtained from reflected signal 22, independently of the height h of aircraft 30. The along-track resolution is obtained through standard SAR processing known in the art. The along-track resolution obtained by synthetic aperture processing is also independent of the height h of aircraft 30, but limited by the along-track real aperture size a_r . Table 1 shows various along-track resolutions obtainable at different radar frequencies.

Table 1
 Achievable Resolutions

Freq. (GHz)	Alt. (FT)	Range Res. (IN)	Along Track Res. (IN)	Cross Track Res. (IN)
1	40	4.5	3	4.5
1	80	4.5	3	9.0
3	40	1.5	1.5	1.5
3	80	1.5	1.5	3.0
9	80	1	1	1
9	240	1	1	3

*Cross track resolution is given in Table 1 for D = 40 ft.

[0025] Cross-track resolution is determined by the array aperture size, i.e., based on width D of antenna array 24 and is given by:

$$\Delta y = h\lambda/2D \text{ where}$$

Δy = Cross-track resolution,
h = Height of aircraft,
D = Width of antenna array, and
 λ = Wavelength.

[0026] Table 1 above shows cross-track resolutions for a 40 foot wide antenna array at various altitudes and radar frequencies. During three-dimensional image processing, a processor 32 on board aircraft 30 receives a signal over connection 34 from receiving array 24. Processor 32 then generates a three-dimensional image which may be stored in a memory 36 also located aboard aircraft 30. Further, processor 32 may also be used to determine the identity of an object corresponding to the image. For example, the three-dimensional image generated by processor 32 may be compared to a previously stored image of a mine in an attempt to determine whether the received image is that of the mine.

[0027] Alternatively, an off-board processor 40 can be used to produce the three-dimensional image and may be able to identify objects corresponding to the received images thereof. Processor 32 transmits data via data link formed by antennas 42 to off-board processor 40. Further, off-board processor 40 can generate the image for viewing on an associated display 44.

[0028] Radar system 10 allows for the mapping of a subsurface minefield by detecting a three-dimensional section of the minefield layout. Such three-dimensional

resolution imaging provides advantages not possible with conventional two-dimensional surface SAR, including the ability to obtain depth information and to provide classification of mines according to shape. In addition, radar system 10 provides radar cross-section (RCS) detection and identification of the interior metal components of plastic mines. Further, the radar system 10 enables the rejection of ground surface reflections, a.c. polarization diversity can be used for image enhancement and the rejection of ground surface reflections.

[0029] An example of a preferred implementation of radar system 10 will now be considered. It will be understood to that this example is provided to enhance understanding of the present Invention and not to limit the scope or adaptability thereof.

[0030] The necessary calculation to determine power requirements for a three-dimensional SAR in a ground penetrating mode of the present invention is provided by the formula:

$$P_T = \frac{SNR(4\pi)^3 h^4 kTLN_F L_{ref} A}{\tau G_T G_R \sigma \lambda^2} \text{ where}$$

SNR	=	signal to noise ratio per pulse (frequency) from receive array = 10 dB
h	=	height = 80 ft
k	=	Boltzmann Constant = 1.38×10^{-23} J/K
T	=	antenna noise temperature = 400K
L	=	system losses = 10 dB
N_f	=	receive noise figure = 7 dB
L_{ref}	=	reflection at earth's surface = 10 dB
A	=	earth attenuation = 10 dB
τ	=	pulse width = .5 μ s
G_T	=	transmit gain = 15.8 dB
G_R	=	receive gain = 32.2 dB
σ	=	Radar cross section = 0.01 m ²
λ	=	0.1 m (Frequency = 3 GHz)
P_{peak}	=	61.0 mW
P_{av}	=	9.5 mW for duty factor 0.155

[0031] In this example, the radar transmitter 12 operates at S-band. Ground attenuation and reflection from surface 16 are factored in when considering the necessary power requirement. The typical peak and average transmit power requirements are in the milliwatt range.

[0032] In this example, the target volume, i.e., the three-dimensional target swath, is 1 nautical mile x 320 feet x 1 foot deep. The on-board processor 32 comprises a 1 gigahertz Pentium PC with a 20 gigabyte storage memory device 38. If all data collected from the three-dimensional swath is transmitted in real-time to an off-board processor, a data link of 5.4 MBPS is provided. One example of an applicable datalink is the high bandwidth data link (CHBDL) which is used by the U.S. Navy and

which has a capacity of 274 MBPS. If all the data is stored on-board aircraft 30, and then transferred off-board for processing after the aircraft lands, the on-board storage memory requirement is about 0.4 gigabytes.

[0033] In order to effectively discriminate between mines and other debris such as rocks and roots, the present radar system operates at high frequencies. However, at such high frequencies, ground attenuation increases dramatically as the radar frequency increases. Therefore, it is preferable to select a desired frequency by factoring in ground attenuation when maximizing image resolution.

[0034] A second area of concern is that the reflection from the surface 16 will disrupt three-dimensional imaging. The reflection produces a large return which must be range-gated out in order for the smaller return radar signal from the buried mine or other target to be discernable. Therefore, it is advantageous for processor 32 to provide range gating.

[0035] In a test of the range gateout functions of the present radar system, a small metal plate was buried in a bucket of moist sand which was illuminated with an impulse-modulated X-band radar. It was determined that the surface of reflection could be ranged out by an on-board processor 32 and/or off-board processor 40. The soil attenuation at X-band was measured and found to be 114 dB/m. A 114 dB/m attenuation is within an acceptable range for a three-dimensional SAR imaging system. Therefore, land mines buried up to one foot in depth may be readily detected from an aircraft flown above a target area using the present system's three-dimensional SAR.

[0036] As discussed above, prior to the present invention, no other SAR system operated in high frequencies such as S-band and X-band as it was believed that ground

attenuation would be too severe. However, the inventors have determined that attenuation effects at S-band and X-band were acceptable when using the present system for mines buried at shallow depths. Further, the high frequencies used by the present invention permit the fine resolution necessary for mine classification.

[0037] In addition to detecting mines, the present system may be adapted for use in detecting other objects buried near the surface of the ground. Further, the present system can be used to detect objects beneath the surface of fresh water. Other uses of the present invention include archeological exploration at the surface, detection of buried bunkers, and walls and the detection of buried persons.

[0038] Although the invention has been described above in relation to preferred embodiments thereof, it will be understood by those skilled in the art that variations and modifications can be effected in these preferred embodiments without departing from the scope and spirit of the invention.

ABSTRACT OF THE DISCLOSURE

A radar system for generating a three-dimensional image includes a radar transmitter which is operable to produce a radar signal of a frequency of at least three gigahertz. A plurality of radar receiving antennas from an antenna array. The antenna array is aurally translatable. For example, in one embodiment, the antenna array is disposed along the wings of an aircraft which, in operation, flies over the intended target area. A three-dimensional image is generated from a reflected radar signal returned from the surface of an object in response to the transmitted radar signal. The radar system may be incorporated into an aircraft and adapted to detect subsurface objects such as mines buried beneath the surface of the ground as the aircraft traverses over a target area.

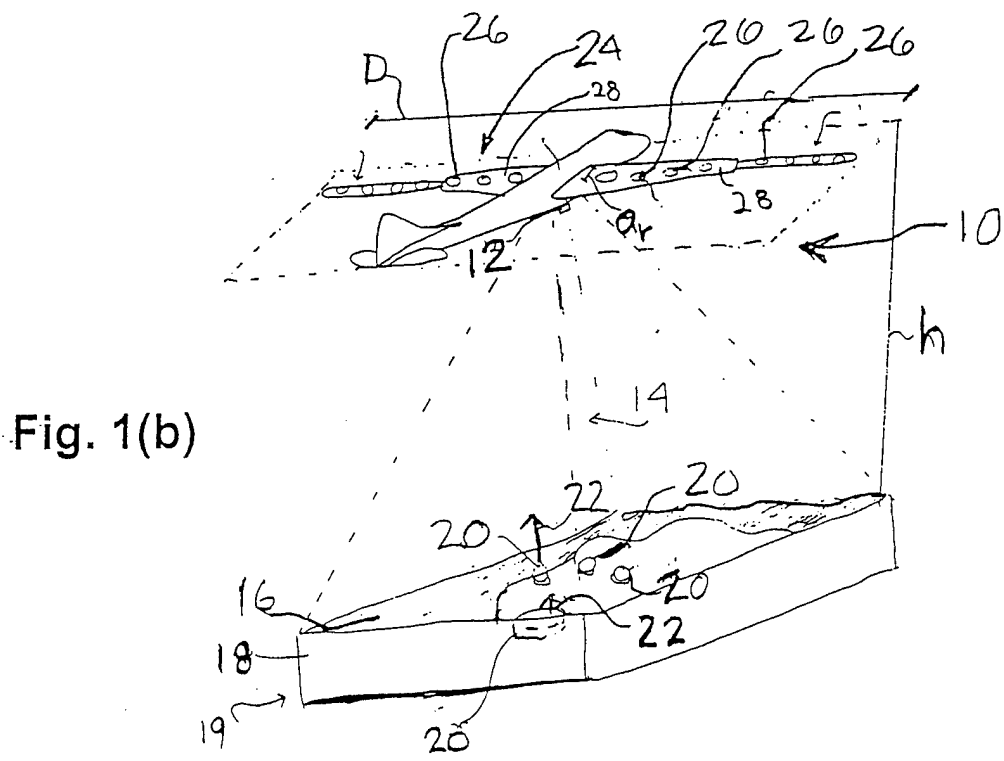
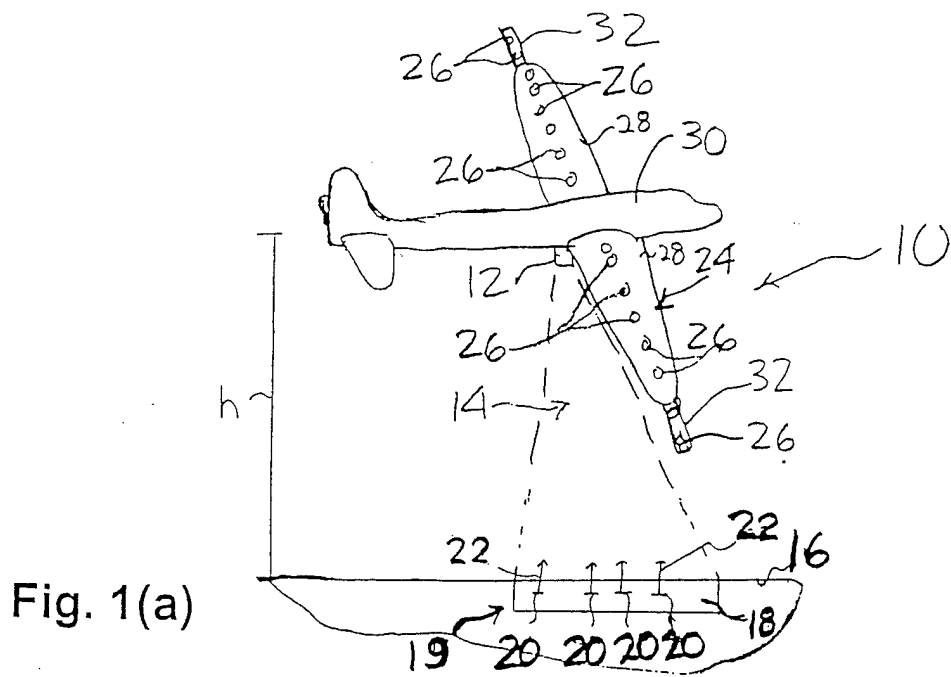

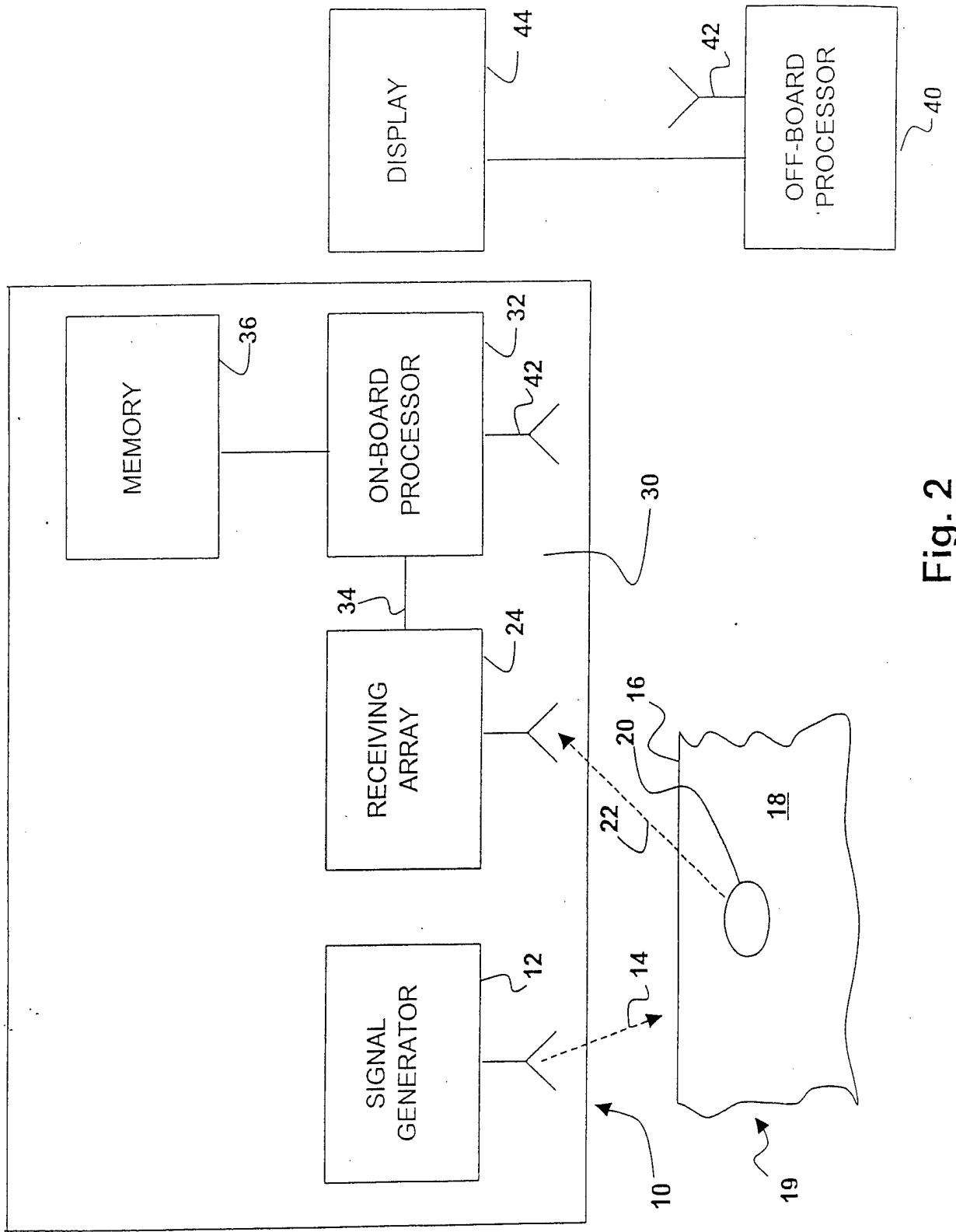

Fig. 2