

Serial Number 09/864,820
Filing Date 24 May 2001
Inventor Vincent J. Vendetti
 Michael J. Canaday
 Charles F. Stevens

NOTICE

The above identified patent application is available for licensing. Requests for information should be addressed to:

OFFICE OF NAVAL RESEARCH
DEPARTMENT OF THE NAVY
CODE 00CC
ARLINGTON VA 22217-5660

20010713 034

RESETTABLE APPARATUS FOR USE WITH TRIGGER MECHANISM

Origin of the Invention

5 The invention described herein was made in the performance of official duties by an employee of the Department of the Navy and may be manufactured, used, licensed by or for the Government for any governmental purpose without payment of any royalties thereon.

Field of the Invention

10 The invention relates generally to resettable mechanisms, and more particularly to a resettable apparatus for use with a trigger that is to be reset after firing.

Background of the Invention

15 In some weapon systems, trigger mechanisms are designed to be fired one time only, at which point they are rendered useless. While such "one time" trigger-mechanisms serve their purpose in actual use, the training of personnel to use the accompanying weapon system is time consuming and expensive as new trigger mechanisms must be installed/used for each training shot. Thus, in a training scenario, it would be preferable to reset the trigger without compromising the feel of a "one time" trigger.

Summary of the Invention

20 Accordingly, it is an object of the present invention to provide a resettable trigger mechanism.

30 Another object of the present invention is to provide a resettable trigger mechanism that requires minimal effort in terms of resetting a trigger to a ready-to-fire position.

Other objects and advantages of the present invention will become more obvious hereinafter in the specification and drawings.

5 In accordance with the present invention, a resettable mechanism for use with a trigger that is to be reset to a ready-to-fire position. An activating rod has a first portion slidably mounted in a housing and a second portion extending from the housing. The activating rod has a notch formed in its first portion. A trigger coupled to the second portion is 10 capable of movement between a ready-to-fire position and a fired position. A first spring is coupled between the activating rod and housing for biasing the second portion towards the housing. A reset rod has a first section slidably mounted in the housing and a second section extending from the 15 housing. The reset rod has a cutout portion formed in its first section for slidably receiving therethrough the first portion of the activating rod. A second spring is coupled between the reset rod and housing for biasing the second section away from the housing. When the trigger is moved from 20 its ready-to-fire position to the fired position, the activating rod is pulled from the housing to align its notch with the cutout portion of the reset rod. At this point, the reset rod moves under the force of the second spring until the reset rod's cutout portion engages the notch. When the 25 trigger is to be moved from its fired position to the ready-to-fire position, the reset rod is pushed towards the housing to disengage the cutout portion from the notch. At this point, the activating rod is free to move under the force of the first spring such that the trigger returns to its ready- 30 to-fire position.

Brief Description of the Drawings

FIG. 1 is a cross-sectional view of a resettable trigger mechanism according to the present invention in its ready-to-fire position;

5 FIG. 2 is a cross-sectional view of a resettable trigger mechanism in its fired position;

FIG. 3 is a cross-sectional view taken along line 3-3 in FIG. 2 illustrating an embodiment of the trigger mechanism's reset rod formed with a groove as its cutout portion; and

10 FIG. 4 is a cross-sectional view of another embodiment of the trigger mechanism's reset rod formed with a through hole as its cutout portion.

Detailed Description of the Invention

15 Referring now to the drawings, and more particularly to FIGS. 1 and 2, an embodiment of a resettable trigger mechanism
10 according to the present invention is shown in its ready-to-fire position (FIG. 1) and in its fired position (FIG. 2).

20 Accordingly, like reference numerals will be used in both views for elements that are common therebetween.

A housing 12 is bored out at 14 to slidably receive a rod 16. More specifically, rod 16 includes a portion 16A maintained within bore 14 and a portion 16B that extends from housing 12 through a reduced diameter portion 14A of bore 14.

25 A corresponding reduced diameter of portion 16B allows an annular sleeve 18 to be defined within housing 12 such that a spring 20 can be captured between housing 12 and rod 16. Spring 20 biases rod 16 into housing 12 as indicated by direction arrow 21. Portion 16A of rod 16 is further notched
30 at 16C for reasons that will become clearer later in the description. To prevent axial rotation of rod 16, portion 16A includes a flat portion 16D that slides on a pin 22 mounted

transverse to rod 16 in housing 12. A trigger 30 is coupled to portion 16B of rod 16.

5 Housing 12 is further bored out at 24 to slidably receive another rod 26 that, in the illustrated embodiment, is perpendicular to rod 16 as shown. More specifically, rod 26 includes a section 26A maintained within bore 24 and a section 26B that extends from housing 12. An annular flange 26C is formed on the outboard end of section 26B. A spring 28 is captured between flange 26C and housing 12 for biasing rod 26 away from housing 12. Part of section 26A is cutout at 26D to allow portion 16B of rod 16 to slidably pass therethrough. Cutout 26D could be an open groove as illustrated in FIG. 3 or could be formed as a through hole 26E as illustrated in FIG. 4.

15 In use, resettable trigger mechanism 10 starts out at its ready-to-fire position illustrated in FIG. 1 where spring 20 is extended and spring 28 is compressed. When trigger 30 is squeezed (i.e., moved in the direction of arrow 40), rod 16 moves axially out of housing 12 until notch 16C is aligned with cutout 26D. At this point, rod 26 is free to move axially away from housing 12 under the force of spring 28 until cutout 26D engages notch 16C as shown in FIG. 2 thereby locking mechanism 10 in its fired position. When it is desired to reset mechanism 10, rod 26 is pushed towards housing 12 as indicated by arrow 42 in FIG. 2. Once this axial movement causes cutout 26D to disengage from notch 16C, rod 16 is again free to move axially into housing 12 under the force of spring 20 so that trigger 30 returns to its ready-to-fire position shown in FIG. 1.

25 The advantages of the present invention are numerous. The resettable trigger mechanism allows a "one time" trigger type of weapon to be used over and over again in a training

scenario. The trigger reset is accomplished by simply pushing a button, i.e., the end of rod 26. In this way, training efficiency is greatly increased as an operator can quickly reset the trigger to prepare for another practice shot.

5 Although the invention has been described relative to a specific embodiment thereof, there are numerous variations and modifications that will be readily apparent to those skilled in the art in light of the above teachings. For example, while each of rods 16 and 26 is illustrated as being of one-
10 piece construction, it is to be understood that these rods can be made in multiple sections to facilitate fabrication and/or assembly for a particular application. Further, the various elements can be solid as shown or hollow in applications where weight is a consideration. Still further, rods 16 and 26 need
15 not be perpendicular to one another as illustrated, but could be positioned at other angles provided the notch (in rod 16) and cutout (in rod 26) were properly formed to allow sliding movement between the rods and positive engagement between the notch and cutout. It is therefore to be understood that
20 _____ the invention may be practiced other than as specifically described.

Abstract

5 A resettable trigger mechanism has an activating rod with a first portion slidably mounted in a housing and a second portion extending from the housing. The activating rod has a notch formed in its first portion. A trigger is coupled to the activating rod's second portion. A first spring coupled between the activating rod and housing biases the second portion towards the housing. A reset rod has a first section slidably mounted in the housing and a second section extending from the housing. The reset rod has a cutout portion formed in its first section for slidably receiving therethrough the first portion of the activating rod. A second spring is coupled between the reset rod and housing for biasing the second section away from the housing. When the trigger is activated, the activating rod is pulled from the housing to align its notch with the cutout portion of the reset rod so that the reset rod can move under the force of the second spring until the reset rod's cutout portion engages the notch. When the trigger is to be reset, the reset rod is pushed towards the housing to disengage the cutout portion from the notch so that the activating rod is free to move under the force of the first spring thereby allowing the trigger to return to its ready-to-fire position.

10

15

20

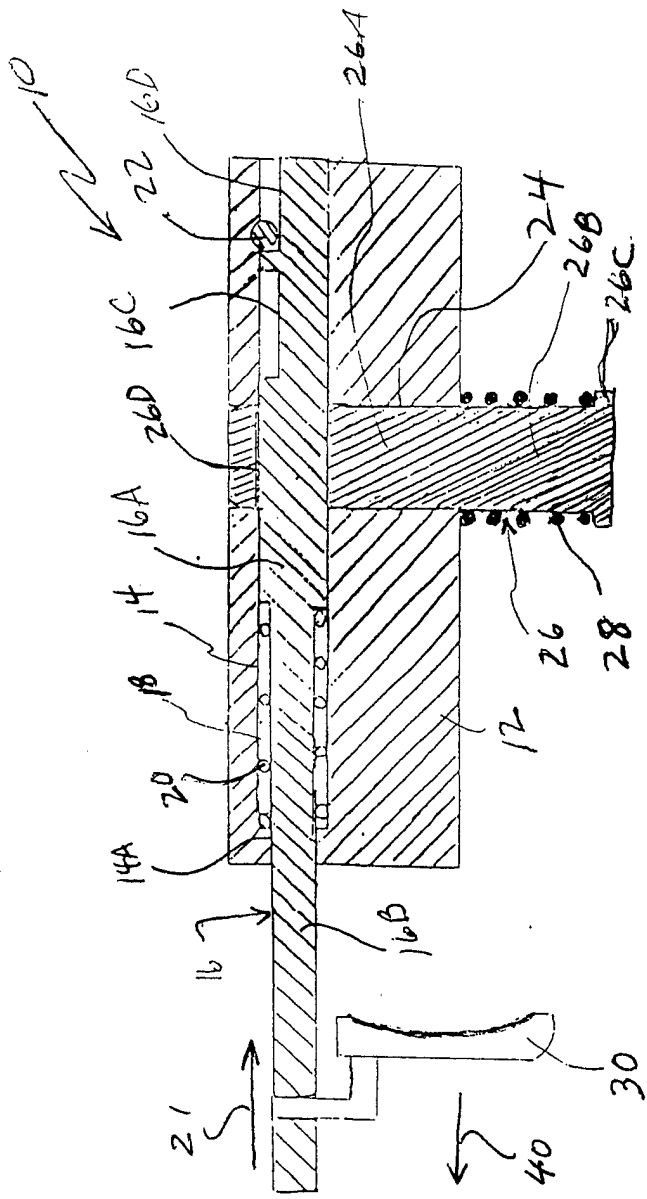

FIG. 1

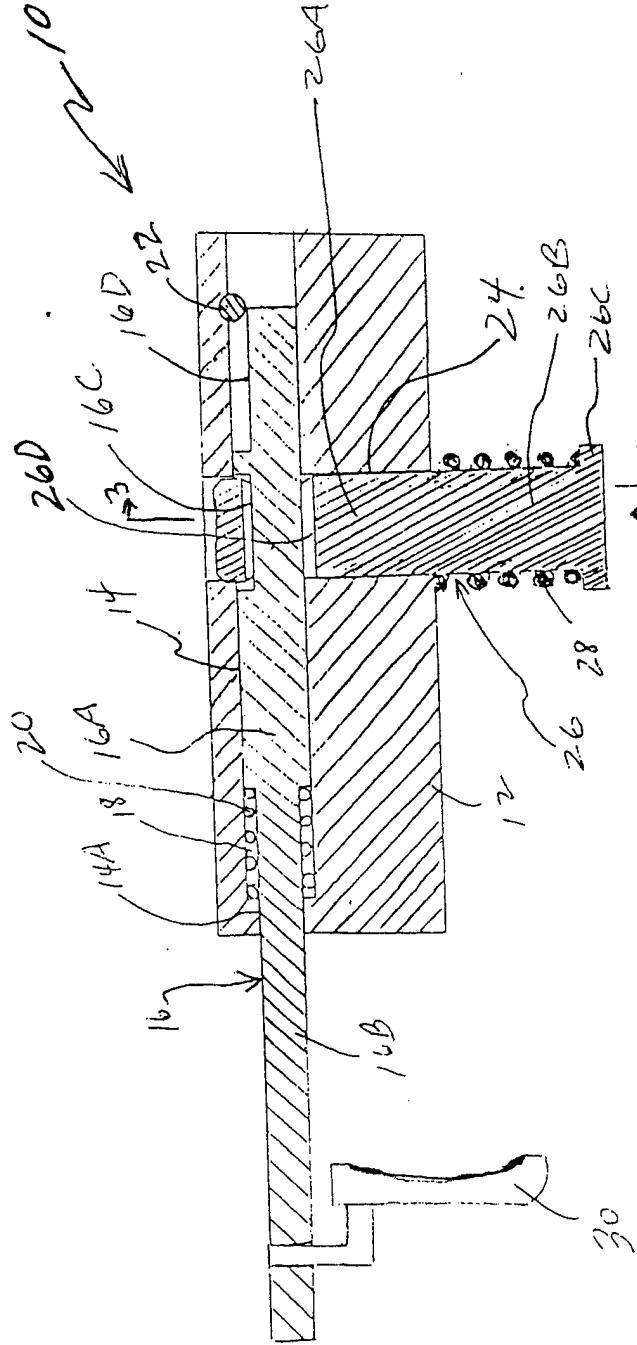

FIG. 2

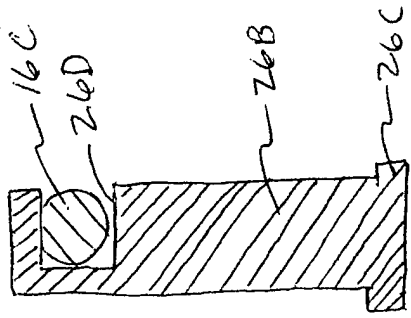

FIG. 3

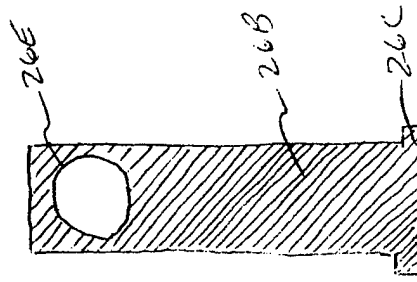

FIG. 4