

Serial No.: 09/725,308

Filing Date: 29 NOVEMBER 2000

Inventor: BELA MOLNAR

NOTICE

The above identified patent application is available for licensing.
Requests for information should be addressed to:

ASSOCIATE COUNSEL (PATENTS)
CODE 1008.2
NAVAL RESEARCH LABORATORY
WASHINGTON DC 20375

DISTRIBUTION STATEMENT A
Approved for Public Release
Distribution Unlimited

20010426 DDL

PATENT APPLICATION/TECHNICAL DIGEST PUBLICATION RELEASE REQUEST

FROM: Associate Counsel (Patents) (1008.2)

TO: Associate Counsel (Patents) (1008.2)

Via: (1) Carmine Carosella (Code 6373)
(2) Division Superintendent (Code 6300)
(3) Head, Classification Management & Control (Code 1221)

SUBJ: Patent Application/Technical Digest entitled: **"PATTERNING OF GaN CRYSTAL FILMS WITH ION BEAMS AND SUBSEQUENT WET ETCHING"**
Request for release for publication.

REF: (a) NRL Instruction 5510.40C
(b) Chapter 6, ONRINST 5870.1C

ENCL: (1) Copy of Patent Application/Technical Digest

1. In accordance with the provision of references (a) and (b), it is hereby requested that the subject Patent Application/Technical Digest be released for publication.

2. It is intended to offer this Patent Application/Technical Digest to the National Technical Information Service, for publication.

3. This request is in connection with Navy Case No. 80,243

12/9/00
(date)



JOHN J. KARASEK
Acting Associate Counsel (Patents)

FIRST ENDORSEMENT

Date:

FROM: Carmine Carosella (Code 6373)
TO: Division Superintendent (Code 6300)

1. It is the opinion of the Inventor(s) that the subject Patent Application/Technical Digest (is) (is not) classified and there is no objection to public release.



Inventor's Signature

SECOND ENDORSEMENT

Date:

FROM: Division Superintendent (Code 6300)

TO: Classification Management & Control (Code 1221)

1. Release of Patent Application/Technical Digest (is) (is not) approved.
2. To the best knowledge of this Division, the subject matter of this Patent Application/Technical Digest (has) (has not) been classified.
3. This recommendation takes into account military security, sponsor requirements and other administration considerations and there in no objection to public release.

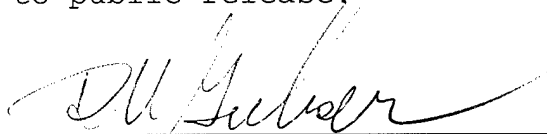

Division Superintendent

THIRD ENDORSEMENT

Date: 4/3/01

FROM: Head, Classification & Control (Code 1221)

TO: Associate Counsel (Patents) (1008.2)

1. This Patent Application/Technical Digest is authorized for public release.

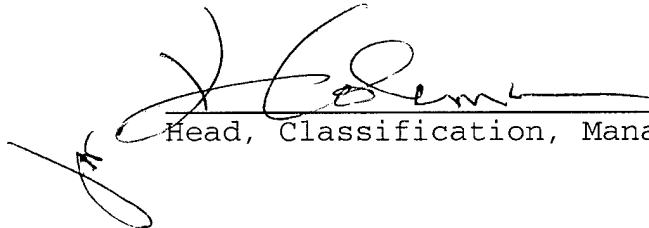

Head, Classification, Management & Control

**PATTERNING OF GaN CRYSTAL FILMS WITH ION BEAMS
AND SUBSEQUENT WET ETCHING**

5

Field of the Invention

The present invention relates to a method for etching nitride and, more particularly, to a wet-etching method for gallium nitride (GaN) enhanced by an imagewise amorphizing step.

10

Description of Related Art

The semiconductor GaN is currently the subject of interest in optoelectronics and in high-power, high-temperature device operations circuits. Specific GaN-based device technologies include light emitting diodes (LEDs), laser diodes, and UV detectors on the photonic side and, on the electronics side, microwave power and ultrahigh power switches. With respect to electronic devices for microwave power applications particularly, one of the main improvements needed is low damage etching that maintains surface stoichiometry.

AlN and Al-rich alloys can be wet etched in KOH at temperatures of 50-100°C. However, under normal conditions, only molten salts such as KOH or NaOH at temperatures above about 250°C have been found to etch GaN at practical rates and, even then, only in certain crystallographic planes. Table I below shows a comparison of etching results for GaN with that obtained with other substrates in a number of acid and basic solutions, performed at room temperature (25°C) unless otherwise noted.

20

20010426 006

TABLE I

Solution	GaN	InN	AlN	InAlN	InGaN
Oxalic acid (75°C)	O	Lifts off	Lifts off	Lifts off	Lifts off
Nitric acid (75°C)	O	Lifts off	Lifts off	Lifts off	Lifts off
Phosphoric acid (75°C)	O	O	Oxide removed	Oxide removed	O
Hydrofluoric acid	O	Lifts off	O	O	Lifts off
Sulfuric acid (75°C)	O	Lifts off	O	O	O
Sodium hydroxide	O	Lifts off	Lifts off	Lifts off	Lifts off
Potassium hydroxide	O	Lifts off	22,650 Angstrom/min	O	O
AZ400K Photoresist developer (75°C)	O	Lifts off	60-10,000 Angstrom/min	Composition dependent	O
Nitric acid/potassium triphosphate (75°C)	O	Lifts off	O	O	O
Nitric/boric acid (75°C)	O	Lifts off	O	O	Lifts off
Nitric/boric/hydrogen peroxide	O	Lifts off	O	O	Removes oxide
HCl/H ₂ O ₂ /HNO ₃	O	Lifts off	O	Lifts off	Lifts off
Potassium tetraborate (75°C)	O	Oxide removal	Oxide removal	Oxide removal	Oxide removal

The difficulty of handling the very strong etching solutions that are required to etch GaN and the inability to find masks that will hold up to them has limited the application of wet etching in GaN device technology. Pearton et al., "GaN: Processing, Defects, and Devices", **Journal of Applied Physics**, 86 (1) at 1, 25-26 (1999).

5 Photochemical etching of n-GaN using 365 nm illumination of KOH solutions near room temperature has been reported, and rates of 3000 Angstroms/min have been obtained for light intensities of 50 mW/cm². Minsky et al., **Appl. Phys. Lett.**, 68(11) at 1531 (1996); and C. Youtsey et al., **Appl. Phys. Lett.** 72(5), 560 (1998). However, intrinsic and p-GaN do not etch even under these conditions. And, when etching does occur, it is generally diffusion limited and
10 produces undesirably rough surfaces. Further, undercut encroachment occurs in some small-scale features due to light scattering and hole diffusion in the GaN itself. Pearton et al. at 25.

Due to the limited wet chemical etch results for the group-III nitrides, such as GaN, a significant amount of effort has been devoted to the development of dry etch processing. Dry etch development was initially focused on mesa structures where high etch rates, anisotropic
15 profiles, smooth sidewalls, and equirate etching of dissimilar materials were required. For example, commercially available LEDs and laser facets for GaN-based laser diodes have been patterned using reactive ion etch (RIE). However, as interest in high power, high temperature electronics has increased, etch requirements have expanded to include smooth surface morphology, low plasma-induced damage, and selective etching of one layer over another. Dry
20 etch development has been further complicated by the inert chemical nature and strong bond energies of the group-III nitrides, as compared to other compound semiconductors. GaN has a bond energy of 8.92 eV/atom, InN 7.72 eV/atom, and AlN 11.52 eV/atom, as compared to

GaAs, for example, which has a bond energy of 6.52 eV/atom. Pearton et al. at 28.

Dry plasma etching has become the dominant patterning technique for the group-III nitrides due to the shortcomings of wet chemical etching. Plasma etching proceeds by either physical sputtering, chemical reaction, or a combination of the two that is often referred to as "ion-assisted plasma etching." Physical sputtering involves the acceleration of energetic ions formed in the plasma to the substrate surface at relatively high energies, typically >200 eV. Due to the transfer of energy and momentum to the substrate, substrate material is then ejected from the surface. However, sputter mechanisms can result in significant damage, rough surface morphology, trenching, poor selectivity and nonstoichiometric surfaces, thus minimizing device performance. Pearton et al. at 28-29.

Chemically dominated etch mechanisms rely on the formation of reactive species in the plasma, which adsorb to the surface, form volatile etch products, and then desorb from the surfaces. While plasma-induced damage is minimized due to the lower ion energies used, etch rates in the vertical and lateral direction are often similar, resulting in the loss of critical dimensions. Alternatively, ion-assisted plasma etching relies on both chemical reactions and physical sputtering to yield acceptable anisotropic profiles at reasonably high etch rates. By balancing the chemical and physical components, high resolution features with minimal damage can be realized. Pearton et al. at 29.

Reactive ion etching (RIE) uses both the chemical and physical mechanisms to achieve fast etch rates and dimensional control. RIE plasmas are typically generated by applying a radio frequency (rf) power of 13.56 MHz between two parallel electrodes in a reactive gas. RIE results have been obtained for SiCl_4 -, HBr -, CHF_3 - and CCl_2F_2 -based plasmas with etch rates typically

<600 Angstroms/min. Plasma damage can occur and degrade both electrical and optical device performance, and the amount of this damage can only be reduced by slowing etch rates, which significantly limits critical dimensions. Related processes include the use of high-density plasma etch systems, such as electron cyclotron resonance (ECR), inductively coupled plasma (ICP) and magnetron RIE (MRIE); chemically assisted ion beam etching (CAIBE) and reactive ion beam etching (RIBE); and low energy electron enhanced etching (LE4). Pearton et al. at 29-30.

In all of these, dry etch characteristics are dependent upon plasma parameters, including pressure, ion energy, and plasma density. Other factors include the substrate temperature and the volatility of the etch products formed. Due to the complexity of dry etch processes, redeposition, polymer formation, and gas-phase kinetics can also influence the results. Pearton et al. at 31-33.

Etch profile and etched surface morphology can be critical to post-etch processing steps, including the formation of metal contacts, the deposition of interlevel dielectric and passivation films, or epitaxial regrowth. Sidewall morphology is especially critical in the formation of laser mesas for ridge waveguide emitters or for buried planar devices. The vertical striations often observed in the GaN sidewalls are often due to striations in the photoresist mask that are transferred to the GaN feature during the etch. While GaN sidewall morphology etched in an ECR using a SiO₂ mask can be improved, this involves optimizing the lithography process used to pattern the SiO₂ and often requires a low temperature dielectric overcoat to protect the resist sidewall during the etch. Rough etch morphology often indicates a nonstoichiometric surface due to preferential removal of either the group III or group-V species. Pearton et al. at 36-37.

Plasma-induced damage also often degrades the electrical and optical properties of compound semiconductor devices. Nonstoichiometric surfaces, created by preferential loss of

the one of the lattice constituents, may be attributed to higher volatility of the respective etch products, leading to enrichment of the less volatile species or preferential sputtering of the lighter element. Thus, reliable and well-controlled patterning of group-III nitrides can be achieved by a variety of dry etch platforms but, to obtain very smooth, anisotropic pattern transfer, a wide range of factors for different plasma etch platforms, chemistries and conditions must be carefully balanced to produce a fast etch rate, high resolution features, and low damage. Pearton et al. at 37-39. Further, the dry etching process is also equipment intensive and relatively expensive. In view of the foregoing, it is an object of the invention to provide a method for etching a GaN substrate that takes advantage of the relative simplicity and the dimensional accuracy of wet etching equipment and methods.

Ion implantation has been an accepted method for integrating certain devices into circuits. Specifically, implant isolation has been widely used in compound semiconductor devices for interdevice isolation, such as in transistor circuits or to produce current channeling, such as in lasers. The implantation process can compensate the semiconductor layer either by damage or chemical mechanism.

Typically, there is a minimum dose (dependent on the doping level of the sample) required for the chemically active isolation species to achieve thermally stable compensation. Sometimes, however, doping of GaN by ion implantation requires an encapsulant layer, such as AlN, to minimize GaN decomposition during high temperature activation annealing. The use of an encapsulant layer then necessitates the selective removal of this layer after the annealing treatment. The photoresist developer, AZ-400 K, has acted as such a selective wet etching agent for AlN over GaN.

N implantation (at doses of about 10^{12} - 10^{13} cm⁻³) effectively compensates both p- and n-type GaN. For example, Zolper et al., U.S. Patent No. 5,866,925 issued February 2, 1999, discloses the implantation of GaN films to produce – and p-type regions using Si⁺ and Mg⁺/P⁺ ions and subsequent annealing to activate the implanted ions. For both – and p-type doping, the resistance typically first increases with annealing temperature, then reaches a maximum before demonstrating a significant reduction in resistance after a 850°C anneal for n-type and a 950°C anneal for p-type GaN. This behavior is typical of implant-damage compensation. The implantation-induced defects in GaN appear to be more thermally stable than other III-V semiconductor materials, such as GaAs or InP, where the damage levels begin to anneal out below 700°C. Further work is still being done to understand more precisely the nature of implantation damage in GaN. Pearton et al. at 39.

The inventors have now discovered that GaN can, in fact, be selectively etched with conventional wet etching solutions directly after ion implantation, allowing for the use of etchant materials that are compatible within the semiconductor device manufacturing industry. Further, if ion implantation can itself be performed in an imagewise manner, such as with a focused ion beam, no masking or additional patterning steps may be required. Imagewise, as used herein, is meant to describe a process commonly known and used in semiconductor technology in which ion implantation is controlled and directed to a predetermined location on the GaN film.

Summary of the Invention

According to a first aspect of the present invention, there is provided a method for etching gallium nitride (GaN) comprising the steps of: providing a GaN film; imagewise amorphizing a

portion of the GaN film by ion implantation to form an amorphized portion; and wet etching of the said GaN film having an amorphized portion to remove the amorphized portion.

The GaN film is preferably a wurzite GaN single crystal film, grown either by chemical vapor deposition (CVD) or molecular beam epitaxy (MBE) on a c-plane oriented sapphire substrate, having a thickness of between 1 and 15 micrometers. The GaN film is also preferably semi-insulating.

The imagewise amorphizing preferably includes implanting the GaN film with either B⁺ or Ar⁺ ions utilizing a focused ion beam to form an image. In a preferred embodiment, the ion implantation is carried out at an ion energy between about 30 and 180 keV with a ion dose from about 1 X 10¹⁴ to 5 X 10¹⁶ ions/cm². The amorphized portion may be thermally annealed after said imagewise amorphizing, and may also be covered by an encapsulant layer, for example an AlN film, before being thermally annealed.

The wet etching includes the use of the photoresist developer that comprises an aqueous solution of KOH or NaOH. A preferred commercially available photoresist developer is AZ-400K. The wet etching is preferably carried out at a temperature between about room temperature and 80°C, with an etching rate of from about 5 to about 700 Angstroms/min and a most preferred rate of about 500 to about 700 Angstroms/min is achieved. The etching depth substantially corresponds to the amorphized portion of said GaN film.

According to a second aspect of the invention, there is provided a GaN device made by the method of the invention.

Brief Description of the Drawings

The invention will be described in greater detail with reference to the following figures, wherein:

Fig. 1 is a micrograph of a GaN substrate treated with the method of the invention;

Fig. 2 is a profilometer of a GaN substrate treated with the method of the invention;

Fig. 3A shows the etching profiles of GaN, implanted with 100 keV Ar, in AZ-400K and KOH, at room temperature and 80°C; Fig. 3B shows the etching profiles of GaN implanted with 40 keV Ar and at different ion doses in KOH at 80°C;

Fig. 4 shows the dependence of etching depth on etching time for the implantation of 100 keV Ar ions at different ion doses;

Fig. 5 shows damage calculations for the implantation of 100 keV Ar ions at different ion doses;

Fig. 6 is a graphic representation of the dependence of etching depth on etching time for different Ar ion energies;

Fig 7 is a cross-sectional view illustrating the formation of a buried etchable region; and

Fig. 8 is a cross-sectional view of a waveguide made from the process of Fig. 7.

Detailed Description of the Preferred Embodiments

The GaN film useful in the method of the invention comprises GaN film crystalline material. Preferably, the GaN film is a wurzite GaN single crystal film grown either by chemical vapor deposition (CVD) or molecular beam epitaxy (MBE) on a c-plane oriented sapphire substrate. Typically, the GaN used in the invention is semi-insulating, MOCVD-grown material available from a number of commercial suppliers.

The GaN film may be undoped, and thus highly resistive semi-insulating or doped with various dopants, such as Si and Mg to produce a conductive – or p-type area.

The thickness of the GaN film can vary widely, but typically varies between about 1 and 15 micrometers. Preferably, the GaN film is about 1-3 micrometers in thickness and is formed on a c-plane sapphire substrate. However, any substrate that matches the desired lattice parameters such as a thin interlayer of AlN may be utilized. The surface roughness is preferably about 100 Angstroms.

Imagewise Amorphizing Step

The GaN film of the invention is then subjected to ion implantation. Ion implantation induces damage in GaN proportional to ion energy and ion dose, and the inventors have discovered that the damaged area can be removed in a subsequent wet etching process. The etching depth depends on the ion energy used, as well as on the ion dose, and can be easily controlled. However, a certain level of damage (about 5 displacements per atom) is necessary to initiate the etching.

Useful types of implantation ions for this amorphizing step include B⁺, Ar⁺, Si⁺, Ga⁺, Mg⁺ and He⁺. However, the preferred ions for implantation are Si⁺ or Ar⁺ ions, or Ga⁺ for focused ion beam (FIB) systems. The process of ion implantation and the use of a focused ion beam system for this purpose are commonly available. Argon ion energies, for example, vary widely but typically range from about 30 to about 400 keV, preferably from about 40 to about 180 keV. A particularly preferred ion energy is from about 50 to about 100 keV. High energy implantation of Si ions will be significantly higher, for example, in the range of about 2-4 MeV.

The ion dose also varies widely but typically ranges from about 1×10^{14} to about 5×10^{16} ions/cm² for Ar ions, preferably ranging from about 2×10^{15} to about 5×10^{16} ions/cm².

Ion dosages for Si ions are about the same as for Ar ions.

The process of the invention is independent of crystallographic directions in GaN, because the GaN is amorphized by the ion beam. Further, although patterning of the GaN film is almost always possible by ion implantation through a mask (followed by etching), maskless
5 patterning can also be achieved with a focused ion beam, such as that provided by Micrion 2500. Further still, implantation through masks offers the potential of three-dimensional patterning of GaN.

Ion-implanted GaN films can be annealed after implantation in a conventional tube furnace up to about 1000-1400°C for about one minute in a N₂/H₂ gas mixture for ion activation.
10 However, any temperature that achieves activation, which may be higher for p-type ions, can be utilized as long as the ion is incorporated within the lattice structure.

Upon implantation, the implanted areas may show an elevation without any etching step taking place. For example, such an elevation may vary from about 500 to 1000 Angstroms, preferably from about 800 to about 900 Angstroms.

Wet Etching Step

The wet etchant can be any one of a number of agents that do not ordinarily etch GaN materials, for example, as shown above in Table I. In a preferred embodiment, the wet etchant is either approximately a 1M KOH solution or the photoresist developer AZ-400K, which is a
20 commercially available buffered KOH solution commonly used in the semiconductor photolithographic process and to remove AlN encapsulant layers on GaN crystalline films. However, most preferably, ion-implanted GaN is selectively etched by AZ-400K.

If ion implantation has resulted in a slight elevation, the etching process first removes these elevated areas and then etches down to a deeper depth. Observations of etching depth under various ion-implanted conditions can be correlated with the number of displacements per atoms (dpa) required for amorphization. A number of about 4 dpa at the surface is typically necessary to initiate the etching process. Therefore, etching behavior can be predicted from calculations.

Etch rates as high as 5-700, preferably 500-700, Angstroms/min. can be observed.

Etching tends to take place in two steps:

- a. a rapid, linear removal of the damaged GaN to a depth corresponding to the depth of the amorphous region, and then
- b. a saturation of the etching depth.

Both the first linear etching as well as the final etching depth depend on etching bath temperature, ion energy and ion dose. Studies of etching solutions and etching bath temperatures show that increasing etching bath temperatures also increases the initial etch rate, as well as the final etching depth. For example, while etching at 80°C may etch down to a depth of several hundred Angstroms in the first minute, etching at room temperature is customarily slower, for example, with the final etching depth being reached in about ten minutes. Although temperatures can vary widely, a range of from about room temperature to about 80°C is preferred.

The thickness of the material that easily etches away increases with ion energy and ion dose, and decreases with the ion mass. Etching behavior is predictable from TRIM calculations and measurement of the dpa needed to amorphize GaN. The depth of etching depends primarily on the implantation parameters and increases with increasing ion dose and ion energy.

Accordingly, the final etching depth can be correlated with the depth and degree of damage

induced by ion implantation. Typically, however, ion-implanted regions etch to a depth of about 150 nm, while unimplanted regions normally show no significant etching. Deep etches can be achieved by multiple implants. For example, multiple implants at varying energies produce etching to a total depth of about 1.5 microns.

5 Annealing of highly amorphized samples up to 1000°C for about one minute in a N₂/H₂ gas mixture does not reduce the etch rate, but the etch rate is often reduced by annealing at lower ion doses.

Feature sizes down to about 2.5-10.0 nm are observed when using a focused ion beam. Further, the roughness of the etched surface is typically at least as good as the original surface.

10 EXAMPLES

Example 1

A semi-insulating, MOCVD-grown GaN film was obtained from a commercial supplier. The GaN film was about 3 micrometers thick and formed on a c-plane sapphire substrate. The GaN was implanted with argon ions at 100 keV, 5 X 10¹⁶ ions/cm², through a mask having 15 square holes, 20 micrometers on a side. The GaN was then exposed to the photoresist etchant AZ-400K, a commercially available buffered KOH solution, at 80°C. The ion-implanted squares (A) etched rapidly (45 nm/min.) to a depth of about 150 nm and are shown in Fig. 1. The unimplanted region (B) in Fig. 1 showed no etching. The line (C) in Fig. 1 describes the path of a profilometer tip that was pulled across the same to measure the surface profile.

20 The profilometer results of the etching process are shown in Fig. 2. The etching created a very abrupt step (E). Further, the unetched regions F1 and the etched regions F2 showed similar surface roughness, indicating little change from the original GaN surface roughness.

Example 2

Undoped GaN films on a c-plane sapphire substrate were obtained from Emcore Corporation. The film thickness was about 2 micrometers, and the surface roughness about 100 Angstroms. These GaN films were implanted with Ar ion with ion energies varying from about 40 to 4000 keV and at ion doses ranging from about 2×10^{15} to about 5×10^{16} ions/cm². High energy implantation of Si ions (2 MeV and 2×10^{16} ions/cm²) was also done. All samples were covered with a transmission electron microscope (TEM) grid to create convenient implanted versus unimplanted areas. The implantation with a focused ion beam was performed with a Micrion 2500, using Ga ions of 50 keV and ion doses ranging from about 2×10^{15} to 10^{16} ions/cm². After implantation, the samples were immersed either in the photoresist developer AZ-400K or 1M KOH, both at room temperature and at 80°C. The surface profiles were taken with a KLA TENCOR Profilometer P10.

The unimplanted GaN areas did not show any etching from either AZ-400K or KOH at 80°C. In Fig 3A, the etching behavior for both etchants are shown for an ion energy of 100 keV and an ion dose of 5×10^{16} ions/cm². At both room temperature and 80°C, no significant difference between the two etchants was observed. The etched surface showed about the same surface roughness of about 100 Angstroms as the unimplanted GaN. The implanted areas of these samples showed an elevation of about 850 Angstroms. Etching at 80°C removed these elevated areas and etched down to a depth of about 700 Angstroms in the first minute, which produced a removal of 1550 Angstroms in total. Etching at room temperature was slower, with the removal of the elevated areas requiring about 2.5 minutes and the final etching depth being reached about 10 minutes. Fig. 3B shows GaN implanted with 40 keV Ar and different ion doses in KOH at 80°C.

The etch profile at 80°C seemed to saturate after 10 minutes and then slightly increased. This increase in etching depth after 30 minutes of etch time was accompanied by the formation of pores with a depth of about 800 Angstroms. The final etching depth amounted to about 1600-1700 Angstroms, which is about 500 Angstroms larger than the damage range (1100 Angstroms) calculated with SRIM 2000 for these implantation conditions. To better understand this phenomenon, a cross section TEM image of a sample implanted with a 100 keV Ar ions and an ion dose of 5×10^{16} ions/cm² was taken. These TEM results showed four different regions could be observed:

Region (a) is Pt layer, which is provided as part of the sample preparation process;

Layer (b) with a depth between 100 and 130 nm represents the implanted regions, where Ar bubbles or voids can be observed; and

Region (c), a deeper damage band of about 100 nm shows the same crystalline structure as the underlying GaN, region (d), but with a higher defect density.

For long exposure times (≥ 30 minutes), etching extends into the deeper damage band (c).

For samples implanted with 100 keV Ar and $\geq 10^{16}$ ions/cm², only the formation of pores up to 1500 Angstroms could be observed. For this lower ion dose, the degree of amorphization of the GaN was not sufficient to remove the damaged layer in the subsequent process. Liu et al., *Phys. Rev. B*, 57(4) at 2530 (1998), has reported a threshold ion dose of 6×10^{15} Ar ions/cm² of 180 keV for the amorphization of GaN, which corresponds to about 4-6 dpa. SRIM calculations for 100 keV Ar ions revealed an ion dose of about 10^{16} ions/cm² as sufficient, regarding the magnitude of damage (18 dpa), but located at about 300 Angstroms below the surface. At the surface (50 Angstroms), the calculated number of dpa amounts to only 3, not sufficient to start

etching of the whole implanted area. To keep damage close to the surface, implantations were performed with 40 keV Ar ions at ion doses ranging from about 2×10^{15} to about 2×10^{16} ions/cm² (2-20 dpa). The etching profiles of these samples are shown in Figure 3B. For this ion energy, etching was also observed for an ion dose of 5×10^{15} ions/cm² (5 dpa), but not for an ion dose of 2×10^{15} ions/cm², as expected from SRIM.

GaN implanted with a higher ion energies, where damage is buried more deeply, is not expected to be etched unless the region of implantation is connected by channels to the surface in contact with the etchant. For an ion energy of 400 keV, the formation of pores could still be observed but, for an ion energy of 2 MeV, no etching at all took place. Thus, for practical applications, multiple implants with different ion energies are needed if etching depths of 1-2 microns are desired. In another sample, an etching depth of 1.5 microns was obtained after implantation of 100 keV and 400 keV Ar ions and 2 MeV Si ions.

The above-described process can be utilized to form well defined device structures. As shown in Fig. 7, for example, 2MeV Si ions can be used to produce a buried etchable regions in a GaN substrate. The regions 12 ranges in thickness from 0.5 to 1.5 microns beneath the surface of the GaN substrate. Using multiple implant methods described above, channels 14 are provided from the regions 12 to the surface of the GaN substrate. When etching occurs, the material in the regions 12 and the material in channels 14 are removed to leave a well defined device structure. For example, as shown in Fig. 8, the well defined free-standing device structure 16 remaining after the process is completed functions as a waveguide.

Example 3

An implantation with a FIB was performed to determine whether implantation followed

by wet etching would hold for smaller feature sizes and could be done maskless. Lines of 25 to 200 nm beam diameter (FWHM) were implanted with doses ranging from about 2×10^{15} ions/cm² to 10^{16} ions/cm². For the heavier Ga ions, the amorphization level was reached at lower ion doses and, therefore, etching took place for an implantation dose of about 2×10^{15} ions/cm². This process of FIB implantation followed by wet etching was significantly more rapid than ion milling would have been.

Example 4

A variety of GaN films were used to study the influence of growth method, thickness, carrier concentration and mobility on etching properties. In the first step, the as-grown GaN films were immersed in AZ-400K at room temperature and at 80°C. Some of the GaN films could be etched as grown without any further treatment. Table 2 summarizes the etching results for the different, as-grown GaN films.

TABLE 2

Growth Type	Carrier Conc. (1/cm ³) X 10 ¹⁷	Thickness (micro-meters)	Mobility (cm ² /Vs)	1 Hour 25°C	1 Hour 80°C
MOCVD	1.5	2	-15	No	No
MOCVD	2.5	1.6	+9	No	No
HVPE	0.7	16.0	-630	No	No
MOCVD	3.0	3.1	-300	No	No
MOCVD	S.I.	3.0		No	No
MBE	20.0	2.0	-230	Yes	Yes
MBE	0.1	2.8		Yes	Yes
MBE	1.0	1.0		No	No
MBE	10.0	0.3	+5	Yes	Yes

Table 2 shows that none of the MOCVD GaN films could be etched. In contrast, 3 out of 4 MBE-grown GaN films studied showed an etching in AZ-400K. There did not appear to be any influence of film thickness, carrier concentration or mobility on etching behavior.

However, damaging by ion implantation clearly promoted etching. Some of the MOCVD GaN films were implanted with B and Ar ions of different energies and at various ion doses. The first implantation experiments were performed with Ar ions with a constant ion energy of 100 keV, while the ion dose was varied between 10^{15} and 5×10^{16} ions/cm². The implanted GaN layers turned brown with increasing ion dose and, for the highest ion dose of 5×10^{16} ions/cm², a dark brown, metallic shiny layer was obtain. Four-point probe resistivity measurements on a semi-insulating GaN film implanted with 5×10^{16} Ar ions/cm² showed a conductance of about 100 (ohm-cm)⁻¹.

After ion implantation, the GaN films were immersed in AZ-400K at 80°C. Fig. 4 shows the etching depth for different Ar ion doses and etching times. A linear etching was observed during the first five minutes for the highest ion dose (5×10^{16} ions/cm², circles). The surface roughness of the etched area was comparable to the one of the untreated surface and amounts to ± 100 Angstroms. After five minutes, the etching profile seemed to saturate at about 1400 Angstroms, which roughly corresponded to the damage region induced by ion implantation, which was calculated/estimated by TRM. After about 60 minutes, pores started to develop at the etched surface, up to about 1500 Angstroms in depth. Simultaneously with the development of pores at the etched surface, the etching depth increased slightly more. The etching behavior for the highest implantation dose of 5×10^{16} ions/cm² differed from the ones implanted at lower doses. For all samples implanted with an ion dose of $\leq 10^{16}$ ions/cm², the etching of the

implanted area was accompanied by the presence of deep pores (about 500-1500 Angstroms).

The etching depth (saturation) decreased with decreasing ion dose and was about 1200

Angstroms for 10^{16} ions/cm² and about 500 Angstroms for 5×10^{15} ions/cm². No etching, except

for pore formation, occurred for an ion dose of about 10^{15} ions/cm². Pores with a depth up to

about 1000 Angstroms were present after one hour; they increased to about 1500 Angstroms after
another hour in AZ-400K at 80°C.

Tan et al., **Appl. Phy. Lett.** 69(16), 2364 (1996), has reported amorphization of GaN
after implantation of 90 keV Si ions at ion doses $>10^{16}$ ions/cm² even at the temperature of liquid
nitrogen. At room temperature, the amorphization dose is expected to be higher. For example,
Liu et al., **Nucl. Instr. Meth. B** 148, 396 (1999), have reported that 3×10^{14} Ca⁺ ions/cm² at 180
keV are necessary to initiate amorphization of GaN at 77°K, but 8×10^{14} ions/cm² are needed at
room temperature.

It has also been reported that GaN is amorphized at 77°K with 180 keV Ar ions at about
5-6 dpa. Liu et al., **Phys. Rev. B** 57(4), 2530 (1998). The number of dpa for the ion energies
and ion doses of these experiments were calculated using TRIM. The results of these
calculations for 100 keV Ar ions and ion doses from 10^{15} to about 5×10^{16} ions/cm² are shown in
Fig. 5. For the lowest ion dose, the number of dpa was less than one. Therefore, for this ion
dose, no etching of the implanted GaN was observed. For the higher ion doses, the depth of the
damage region roughly corresponded to the saturation level of the etching depth.

TRIM calculations for the implantation of 1×10^{16} B⁺ ions/cm² with ion energies of 30
and 100 keV revealed a number of dpa at the damage peak of less than 3, too small to amorphize
GaN. Experimental results for GaN implanted with B ions at these doses and energies revealed
no etching.

Example 5

In another set of experiments, the annealing influence at 900°C and 1000°C in N₂/H₂ gas on implanted GaN films (100 keV Ar ions, 10¹⁵ to 5 X 10¹⁶ ions/cm²) was examined. The etch rate for the sample implanted at 5 X 10¹⁶ ions/cm² before and after annealing was the same, and almost all of the etching was completed in the first five minutes. In contrast, the annealing slowed the etch rates for the lower implantation doses (<10¹⁶ ions/cm²), and no saturation was observed. There was also a delayed onset of etching in these samples. At 10¹⁶ ions/cm², etching commenced at 30 minutes; at 5 X 10¹⁵ ions/cm², etching only began after one hour in AZ-400K at 80°C. Again, no etching at all was observed for the lowest implantation dose of 10¹⁵ ions/cm². From these data, it was concluded that some of the amorphizing damage was recoverable at the lower doses, but no recovery was possible at the highest dose.

Example 6

To investigate the effect of ion energy on etching depth, Ar ions of 30 or 180 keV were implanted. The predicted damage range for 30 keV is 400 Angstroms and, for 180 keV, 2000 Angstroms. The ion doses were chosen to result in a comparable dpa. They were 1.6 X 10¹⁶ ions/cm² for 30 keV and 5.5 X 10¹⁶ ions/cm² for 180 keV. In Fig. 6, the results of these etching experiments are presented. The saturation etching depth for 30 keV was 600 Angstroms and, for 180 keV, 2000 Angstroms. For 30 keV, etching of the implanted layer was observed after two minutes, with complete removal after five minutes. At 180 keV, the implanted layer started to etch after five minutes and was completely removed after ten minutes.

Additional advantages and modifications will readily occur to those skilled in the art. Therefore, the invention in its broader aspects is not limited to the specific details and representative embodiments shown and described herein. Accordingly, various modifications

may be made without departing from the spirit or scope of the general inventive concept as defined by the appended claims and their equivalents.

ABSTRACT OF THE INVENTION

The invention provides a method for etching gallium nitride (GaN) comprising the steps of: providing a GaN film; imagewise amorphizing a portion of the GaN film by ion implantation to form an amorphized portion; and wet etching of the GaN film having an amorphized portion to
5 remove the amorphized portion. When the imagewise amorphizing process can be done without a mask, such as with a focused implantation ion beam, the process itself becomes maskless.

Fig. 1: GaN, implanted Ar 100 keV , $5 \cdot 10^{16}\text{ ions/cm}^2$,
etched in AZ-400K for 5 minutes at 80°C

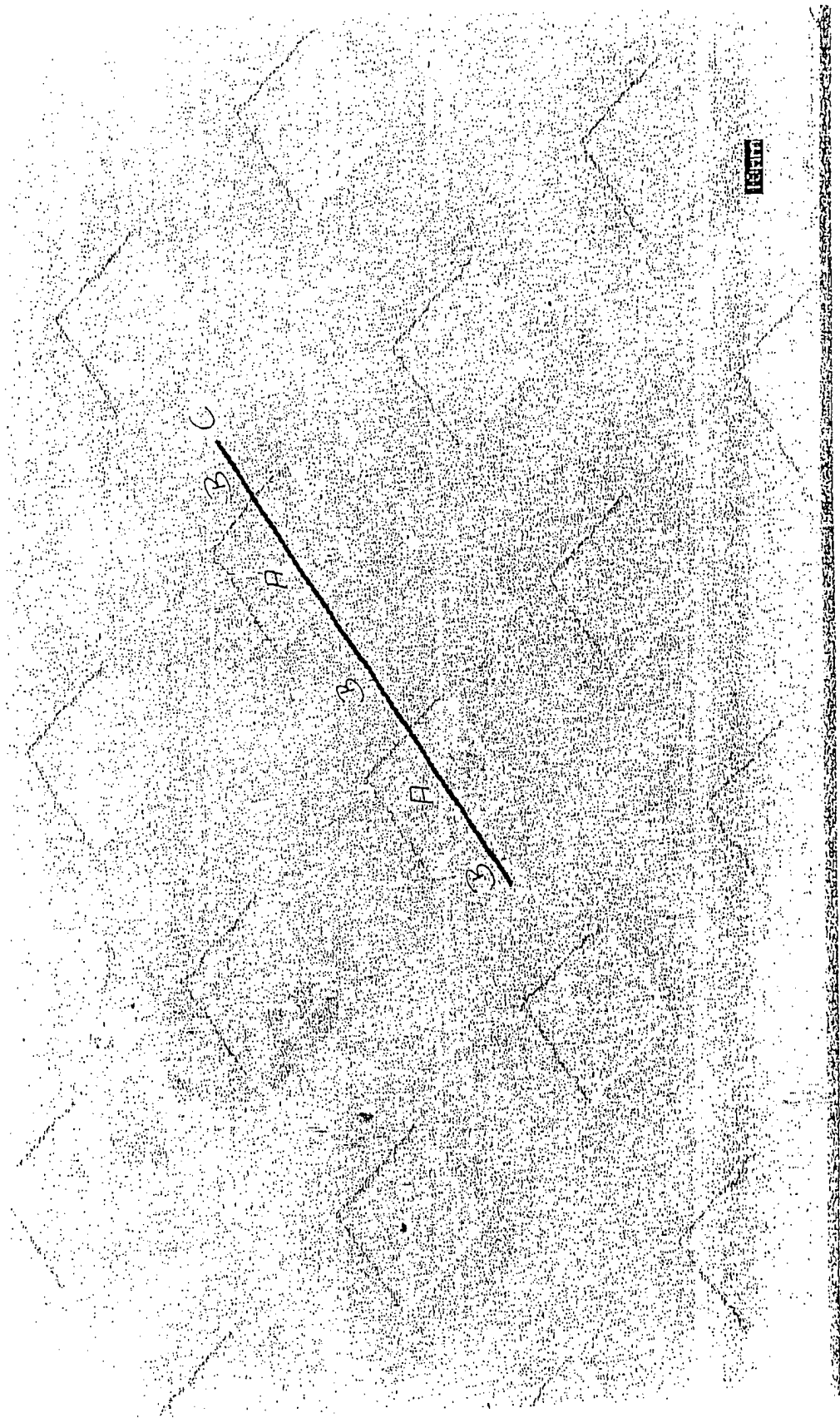

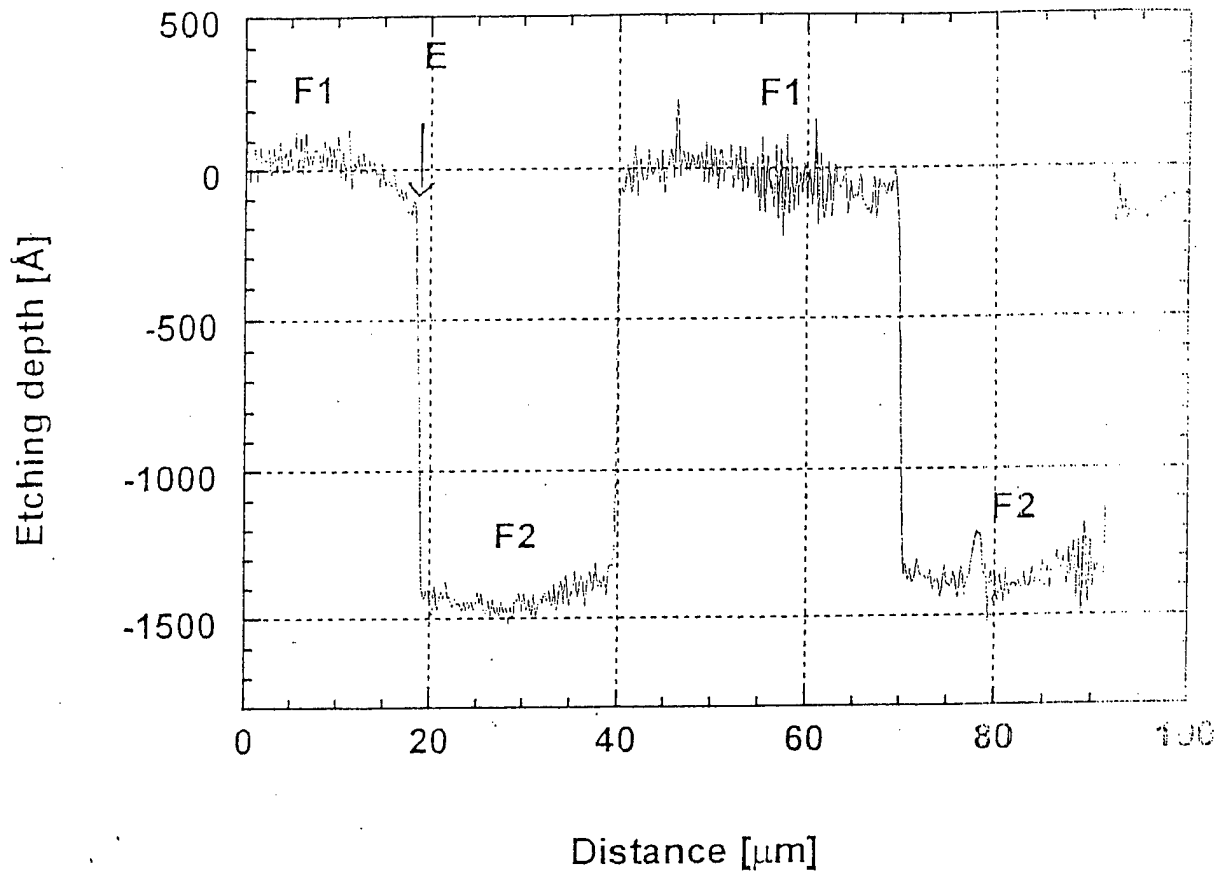

FIG. 2: Profilometer Graph of Etched Squares
in Implanted GaN

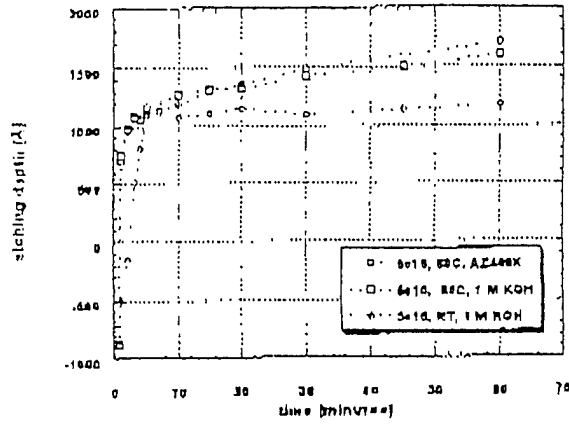

FIG. 3A

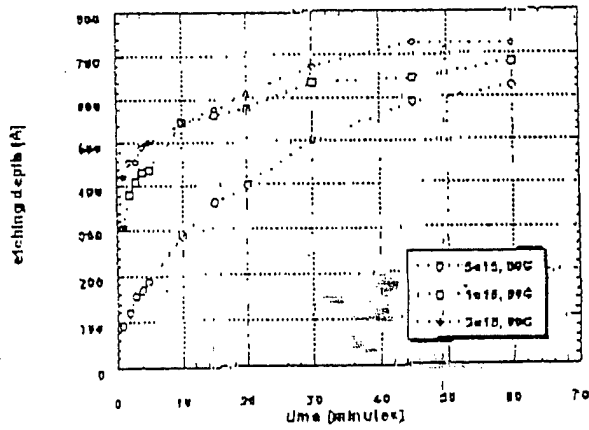
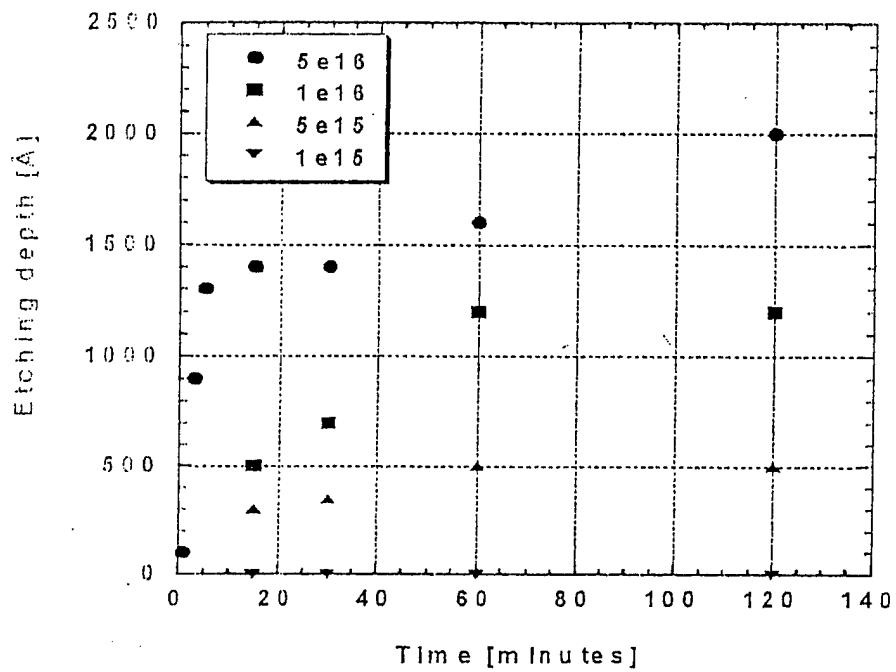
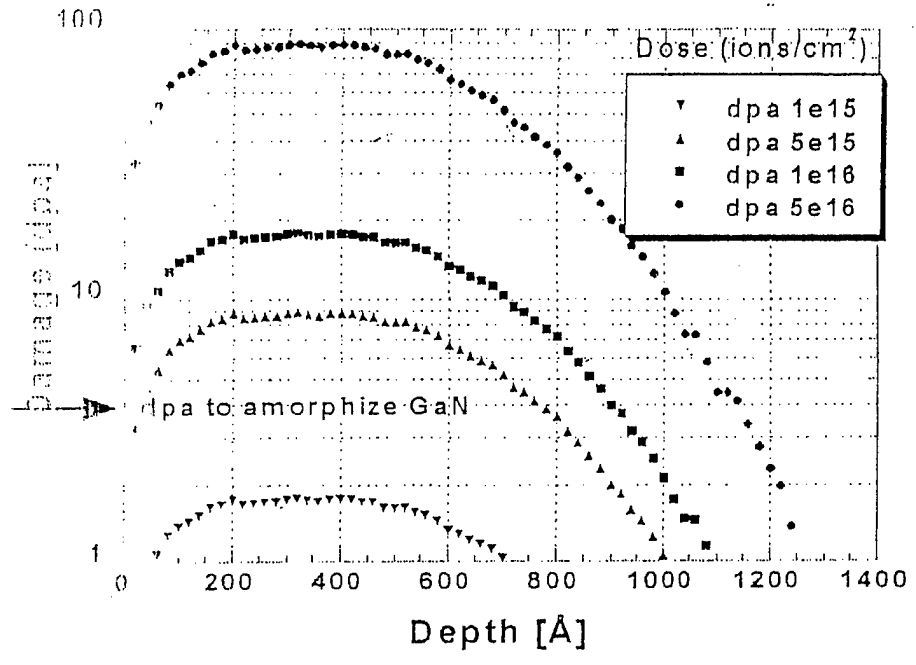

FIG. 3B



Dependence of etching depth on etching time for the implantation of 100 keV Ar ions at different ion doses.

FIG. 4



Damage calculations for the implantation of 100 keV Ar ions at different ion doses.

FIG. 5

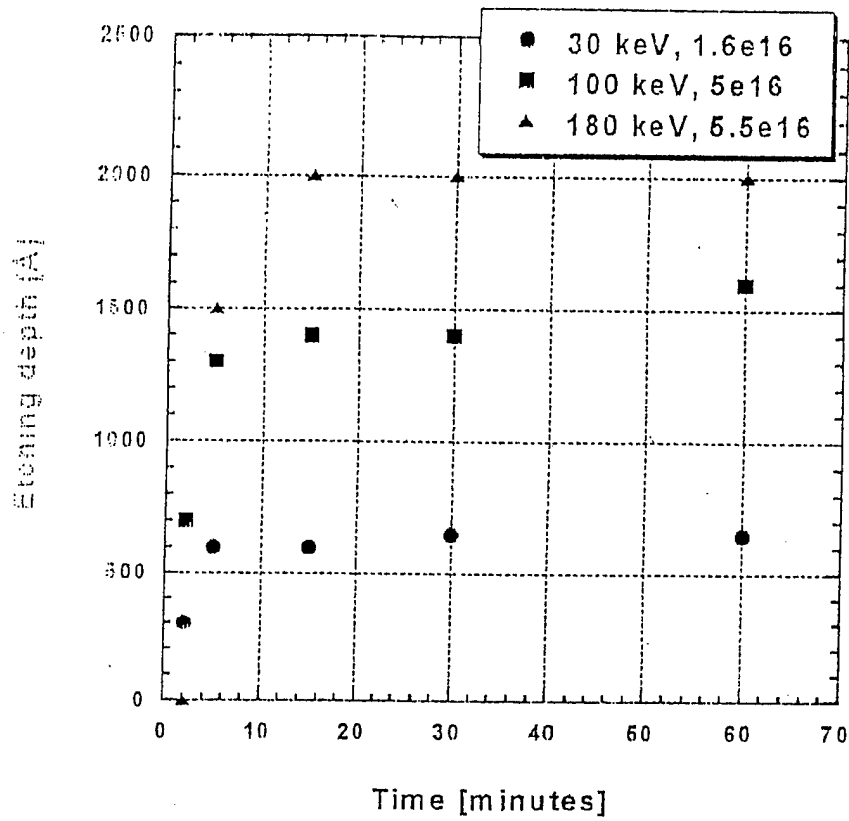

Dependence of etching depth on etching time for different Ar ion energies.

FIG. 2.7b

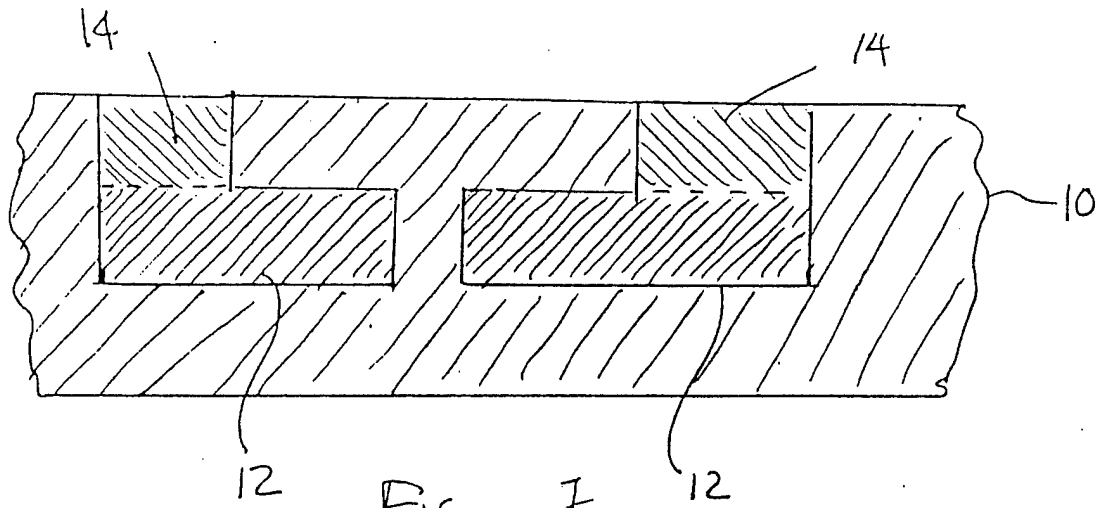

FIG. 7

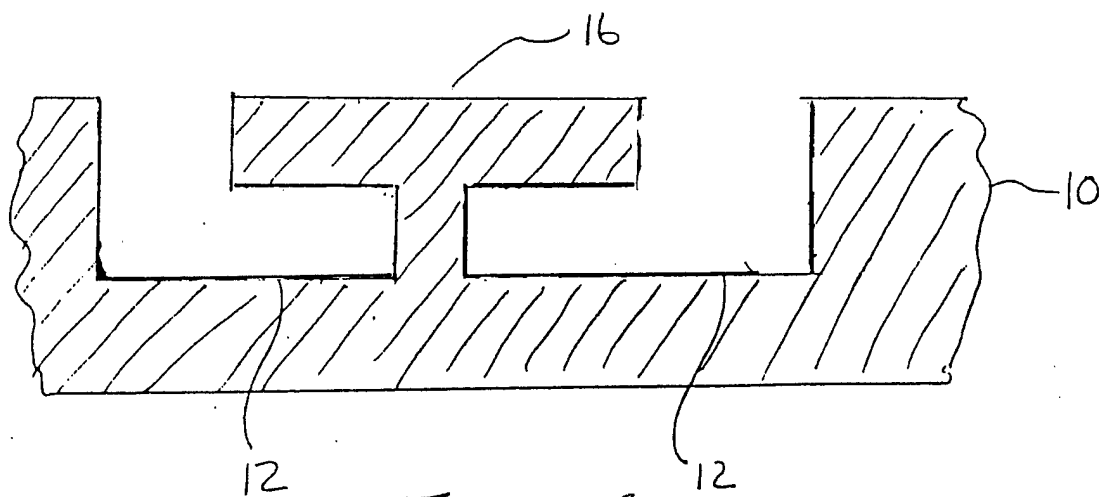

FIG. 8