

Serial Number 09/356,803
Filing Date 19 July 1999
Inventor Michael J. Josypenko

NOTICE

The above identified patent application is available for licensing. Requests for information should be addressed to:

OFFICE OF NAVAL RESEARCH
DEPARTMENT OF THE NAVY
CODE 00CC
ARLINGTON VA 22217-5660

DISTRIBUTION STATEMENT A
Approved for Public Release
Distribution Unlimited

20000508 067

1 Attorney Docket No. 78738

2

3

HELIX ANTENNA

4

5

STATEMENT OF GOVERNMENT INTEREST

6

7

8

9

The invention described herein may be manufactured and used by or for the Government of the United States of America for Governmental purposes without the payment of any royalties thereon or therefor.

10

11

BACKGROUND OF THE INVENTION

12

(1) Field of the Invention

13

14

15

16

The invention relates to a quadrifilar helix antenna and is directed more particularly to such an antenna for use in satellite communications and for disposition on seagoing surface vessels.

17

(2) Description of the Prior Art

18

19

20

21

The antenna currently used onboard ship in satellite communications bands (about 240 MHz to 410 MHz) is a mechanically steered reflector backed dipole assembly which, because of its weight, must be mounted on deck.

1 There exists a need for a simple, rugged, relatively small
2 and lightweight antenna which can be mounted on the mast of a
3 surface vessel and be proficient in wideband satellite
4 communications, including Demand Assigned Multiple Access (DAMA)
5 UHF satellite communications functions in the range of 240 - 320
6 MHz, and for other satellite communications functions in the
7 range of 320 - 410 MHz.

8

9

SUMMARY OF THE INVENTION

10 It is, therefore, an object of the invention to provide a
11 relatively small, lightweight, antenna assembly capable of
12 operation in the satellite communications band range of 240-410
13 MHz, and suitable for mounting on a ship's mast.

14 A further object of the invention is to provide such an
15 antenna assembly as is strong, rugged, and relatively simple to
16 construct.

17 A still further object of the invention is to provide such
18 an antenna requiring no external components, such as matching
19 networks, that require placement at critical locations on the
20 antenna and that have to be protected.

21 With the above and other objects in view, as will
22 hereinafter appear, a feature of the present invention is the

1 provision of a helix antenna comprising a base portion for
2 containing a phase quadrature feed network including a power
3 input, a 90 degree power splitter in communication with the
4 power input, and first and second 180 degree power splitters in
5 communication with the 90 degree power splitter. A support tube
6 is mounted on the base portion, and a plurality of disk
7 separators are mounted on the tube and are spaced from each
8 other and extend radially outwardly from the tube. Four
9 elongated elements are wound around the support tube and are
10 spaced therefrom by the disk separators, the elements being
11 connected to end-most lower and upper ones of the disk
12 separators, the elements extending toward a center feed point of
13 the upper disk separator and comprising radial feed arm portions
14 of the four elements. First and second radially opposite pairs
15 of feed cables are wound about the support tube, attached to the
16 inside middles of the elements and extending from the lower disk
17 separator to the upper disk separator, and are in communication,
18 respectively, with the first and second 180 degree power
19 splitters.

20 The above and other features of the invention, including
21 various novel details of construction and combinations of parts,
22 will now be more particularly described with reference to the

1 accompanying drawings and pointed out in the claims. It will be
2 understood that the particular device embodying the invention is
3 shown by way of illustration only and not as a limitation of the
4 invention. The principles and features of the invention may be
5 employed in various and numerous embodiments without departing
6 from the scope of the invention.

7

8 BRIEF DESCRIPTION OF THE DRAWINGS

9 Reference is made to the accompanying drawings in which is
10 shown an illustrative embodiment of the invention, from which
11 its novel features and advantages will be apparent, wherein
12 corresponding reference characters refer to corresponding parts
13 throughout the several views of the drawings and wherein:

14 FIG. 1 is a side elevational view, in part broken away, of
15 housing, base portion, support tube, and disk separator
16 components of an antenna assembly illustrative of an embodiment
17 of the invention;

18 FIG. 2 is a perspective view of four elongated elements for
19 disposition in combination with the components of FIG. 1;

20 FIG. 3 is a side elevational view, in part broken away, of
21 the components of FIG. 1 in combination with the components of
22 FIG. 2, and further in combination with feed cables;

1 FIG. 4 is a perspective view of the antenna assembly of
2 FIG. 3;

3 FIG. 5 is a schematic diagram of the feed network and feed
4 cables of the antenna assembly;

5 FIG. 6 is a diagrammatic top plan view of the antenna
6 assembly;

7 FIG. 7 is a VSWR vs. frequency plot for the antenna; and

8 FIG. 8 is a representative pattern of the antenna at 280
9 MHz.

10

11

DESCRIPTION OF THE PREFERRED EMBODIMENT

12

Referring to FIG. 1 and also to FIG. 5, it will be seen
13 that an illustrative embodiment of the invention includes a base
14 portion 20 for containing a phase quadrature feed network 22,
15 including a power input 24 (FIG. 5), a 90 degree power splitter
16 26 in electrical communication with the power input 24, and
17 first and second 180 degree power splitters 28, 30 (FIG. 5).

18

Input ports 32, 34 (FIG. 5) of the 180 degree power
19 splitters 28, 30, respectively, are connected to 0 and 90 degree
20 output ports 36, 38 of the 90 degree power splitter 26. A dump
21 port 40 of 90 degree power splitter 26 is terminated in a 50 ohm

1 termination 42 which is adapted to handle any mismatch of the
2 antenna.

3 A support tube 44 is mounted on base portion 20 and extends
4 therefrom. The support tube 44 preferably is of fiberglass with
5 a wall thickness of about 1/4 inch.

6 A plurality of disk separators 46, 48, 50 and 52 are
7 mounted on support tube 44 and are spaced from each other by
8 substantially equal intervals. The disk separators 46, 48, 50,
9 52 extend radially outwardly from support tube 44. Disk
10 separators 46, 48, 50, 52 preferably are about 9 inches in
11 diameter. The disk separators 48, 50, 52 are of fiberglass, or
12 the like. The disk separator 46 is of metal, provided for
13 purposes of shorting elements, to be described hereinbelow.

14 Referring now to FIGS. 2-4, four elongated elements 54, 56,
15 58, 60 (FIGS. 2-4) are wound around support tube 44 and are
16 spaced therefrom by disk separators 46, 48, 50, 52. (In FIG. 3,
17 the span of the elements 54-60 are shown as 54a-60a,
18 respectively) The elements 54, 56, 58, 60 are connected to the
19 lower and upper end-most disks 46, 52. The elements 54, 56, 58
20 and 60 extend radially inwardly toward a center feed point 62 on
21 a top surface 64 of the upper end disk 52 (FIGS. 2 and 6). The
22 physical and r.f. separation between adjacent elements is 90

1 degrees. The angle at which an element starts a wrap around
2 tube 44 is the pitch angle 66 (FIGS. 3 and 4). The elements 54,
3 56, 58, 60 are fed from the center feed point 62 at the upper
4 end of the antenna. The upper ends of the elements 54, 56, 58,
5 60 are extended radially inwardly (FIGS. 2, 4, 6). By feeding
6 the four elements 54, 56, 58, 60 at center feed point 62 in
7 phase quadrature, a cardoid shaped pattern can be radiated
8 either from the feed end 52 of the antenna (backfire mode) or
9 from the opposite end 46 of the antenna (forward fire mode).
10 Less backside radiation occurs when the antenna is fed in
11 "backfire" mode, as opposed to "forward fire" mode. Thus, it is
12 preferable that the antenna be fed at its top 52. At the lower
13 end of the antenna, the elements 54, 56, 58, 60 are continued by
14 extending radially towards the center of the lower end disk 46.
15 The elements can be connected by shorts 68, 70 (FIG. 2). If so
16 connected, the antenna is referred to as being "shorted".
17 Without the shorts 68, 70, the antenna is referred to as being
18 "open". Alternatively, the elements at the lower end may be
19 connected together by being bolted to separator disk 46, which
20 is of metal, and which serves as a radial short. The effect of
21 the shorts appears to be minimal.

1 The elements 54, 56, 58, 60 may be of metal wire, metal
2 tube, or metal strip. The diameter or width of the element and
3 its pitch angle 66 determine the characteristic impedance Z_0 of
4 the antenna. With a long enough element, the diameter also
5 determines the "cut in" frequency of the antenna, i.e., the
6 frequency above which the antenna has a low VSWR, broadband
7 impedance match. In this case, one turn of an element must be
8 roughly $1/2$ wavelength in length at "cut in". The minimum
9 length of an element is about $3/4$ wavelength to provide a "cut
10 in" frequency at 200 Mhz (FIG. 7 where opposite pairs of feed
11 cables are shown by lines 200 and 202). Shown in the drawings
12 are metal strip type elements 54, 56, 58, 60, shown as
13 transparent (FIG. 3) and partially (FIG.4) for illustrative
14 purposes, so as to show the interior of the antenna which, in
15 reality, is obscured by the metal strip elements. A preferred
16 width of each metal strip element and its pitch angle preferably
17 is selected for an antenna characteristic impedance of 100 ohms,
18 so as to match the 100 ohm input impedance of the feed of 180°
19 degree power splitters 28, 30 and thus require no matching
20 circuits.

21 The cylinder formed by the end disks 46, 52 and elements
22 54, 56, 58, 60 preferably is about 39.25 inches long and about 9

1 inches in diameter. The metal strip elements preferably are of
2 copper and are of a width of about 4.5 inches and a thickness of
3 $1/16 - 1/8$ inch. The preferred pitch angle 66 is 42.5° . A gap
4 71 (FIGS. 2-4) between metal strip elements is about .2388 inch
5 for $1/8$ inch thick elements and less for $1/16$ inch elements,
6 maintaining the 100 ohm impedance of the antenna.

7 The antenna further includes first and second radially
8 opposite pairs of feed cables 72, 76; 74, 78 (FIGS. 3 and 4).
9 The feed cables are in electrical communication with the 180°
10 power splitters 28, 30 (FIG. 5). The cables preferably are
11 simirigid 50 ohm cables and are of .141 inch diameter. The
12 cables are introduced at points 80, 82, 84, 86 (FIGS. 3 and 4;
13 point 84 is hidden in these views but is opposite point 80
14 between points 82 and 86), pass through the lower end disk
15 separator 46, mounted on the inside centers of elements 54, 56,
16 58, 60, and spiral around the support tube 44. The feed cables
17 72, 74, 76, 78 are thus protected physically by the metal strip
18 elements 54, 56, 58, 60.

19 The disk separators 46, 48, 50, 52 keep tube 44 a
20 reasonable distance from elements 54, 56, 58, 60 to prevent tube
21 44 from dielectrically loading the elements. Loading the

1 elements is undesirable as it produces more backside radiation.
2 Notches 88 (FIG. 4) are provided on the perimeters of disk
3 separators 46, 48, 50, 52 where the gaps 71 between elements 54,
4 56, 58, 60 cross the disks, to prevent the disks from
5 dielectrically loading the gap regions of the elements, where
6 the fields are dense.

7 The elements 54, 56, 58, 60 are fed from the center feed
8 point 62 at the top end. The upper ends of the elements are
9 truncated (FIGS. 2-4, 6) and extend inwardly toward the center
10 feed point 62 to serve as radial feed arms 90, 92, 94, 96. The
11 feed cables 72, 74, 76, 78 are directed radially inwardly by the
12 feed arms 90, 92, 94, 96. Feed cables 72, 76 at their upper
13 ends are interconnected by a center conductor 98, and feed
14 cables 74, 78 are connected together by a center conductor 100
15 (FIG. 6). The center conductors 98, 100 are insulated. The
16 ends of the feed cables 72, 74, 76, 78 outer conductors 102
17 (FIG. 6), are connected to their respective elements 90, 92, 94,
18 96 to serve as the feed points for the elements. The ends of
19 feed cables 72, 74, 76, 78 and the center conductor 98, 100 are
20 covered with a plastic material (not shown) to protect the
21 cables and conductors from the environment. In addition, a
22 topcap (not shown) of fiberglass, or the like, may be placed on

1 the upper end of the antenna to prevent foreign material from
2 contaminating the feed region. The feed cables 72, 74, 76, 78
3 being introduced at the shorted bottom end 46 of the antenna,
4 spiraling up elements 54, 56, 58, 60 and across the upper end
5 arrangement facilitates the use of the entire antenna as an
6 infinite balun.

7 In operation, the 180 degree power splitters 28, 30 provide
8 180 degree phase difference between two radial opposite elements
9 (72, 74; 76, 78), and also match the 100 ohm impedance between
10 the feed arms to the 50 ohm input impedance of the splitters.
11 The two inputs of the splitters are fed with the 0° and 90°
12 output ports 36, 38 of 90° splitter 26, resulting in a
13 quadrature feed phase for elements 54, 56, 58, 60, i.e.,
14 adjacent elements are 90° out of phase with each other.

15 The RF height of the antenna can be reduced by introducing,
16 physical shorts (not shown) across the gaps 71 between the
17 elements at the base of the helix and moving them up along the
18 gaps for 2-8 inches. By adjusting the RF height the sharpness
19 of the patterns can be adjusted so as to favor either the DAMA
20 transmit or receive bands. For example, reducing the height
21 sharpens the patterns, that is, makes the patterns more pointed
22 overhead, thus reducing pattern flattening at higher

1 frequencies. This helps reduce loss of gain in overhead
2 flattening in the transmit band and reduces gain near the
3 horizon in the receive band.

4 There is thus provided a small, lightweight antenna that is
5 rugged and simple to construct, and suitable for mounting on a
6 surface ship mast. There are no external RF components, such as
7 matching networks, required to be placed at critical locations
8 on the antenna.

9 There is further provided such an antenna exhibiting
10 patterns and impedances (VSWR of about 2:1) suitable for DAMA
11 and other satellite communications, in a band range of 240-410
12 Mhz. FIG. 8 shows a representative pattern (line 210) of the
13 antenna at 280 MHz.

14 It will be understood that many additional changes in the
15 details, materials, and arrangements of parts, which have been
16 herein described and illustrated in order to explain the nature
17 of the invention, may be made by those skilled in the art within
18 the principles and scope of the invention.

19

1 Attorney Docket No. 78738

2

3

HELIX ANTENNA

4

5

ABSTRACT OF THE DISCLOSURE

6 A helix antenna includes a base portion for containing a
7 feed network including a power input, a 90 degree power splitter
8 in communication with the power inlet, and first and second 180
9 degree power splitters in communication with the 90 degree power
10 splitter. A support tube is mounted on the base portion, and a
11 plurality of disk separators are mounted on the tube. Four
12 elongated elements are wound around the tube and are spaced
13 therefrom by the disk separators. The elements are connected to
14 end-most lower and upper ones of the disk separators, the
15 elements extending toward a center feed point of the upper disk
16 separator. First and second radially opposite pairs of feed
17 cables are wound around the support tube, extending from the
18 lower disk separator to the upper disk separator, and are in
19 communication, respectively, with the first and second 180
20 degree power splitters.

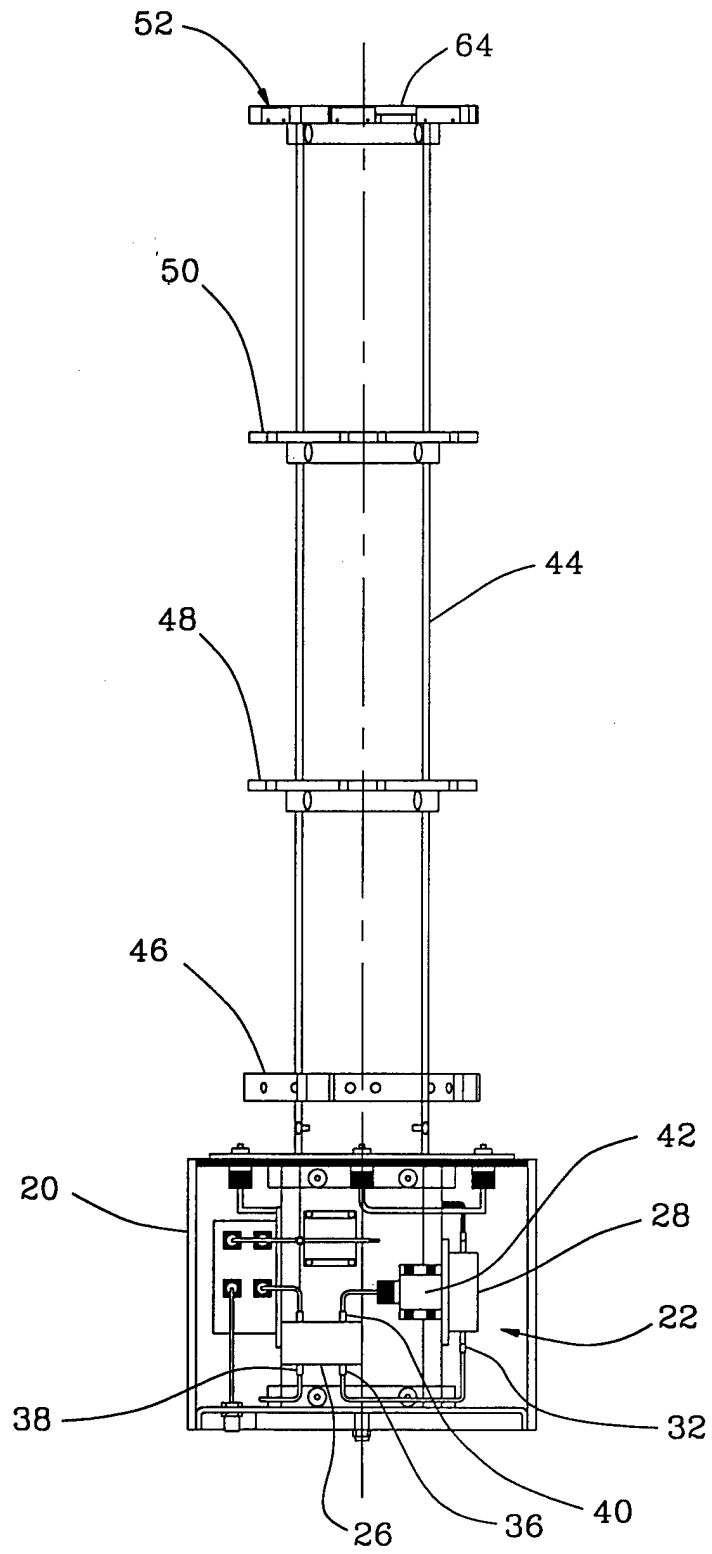

FIG. 1

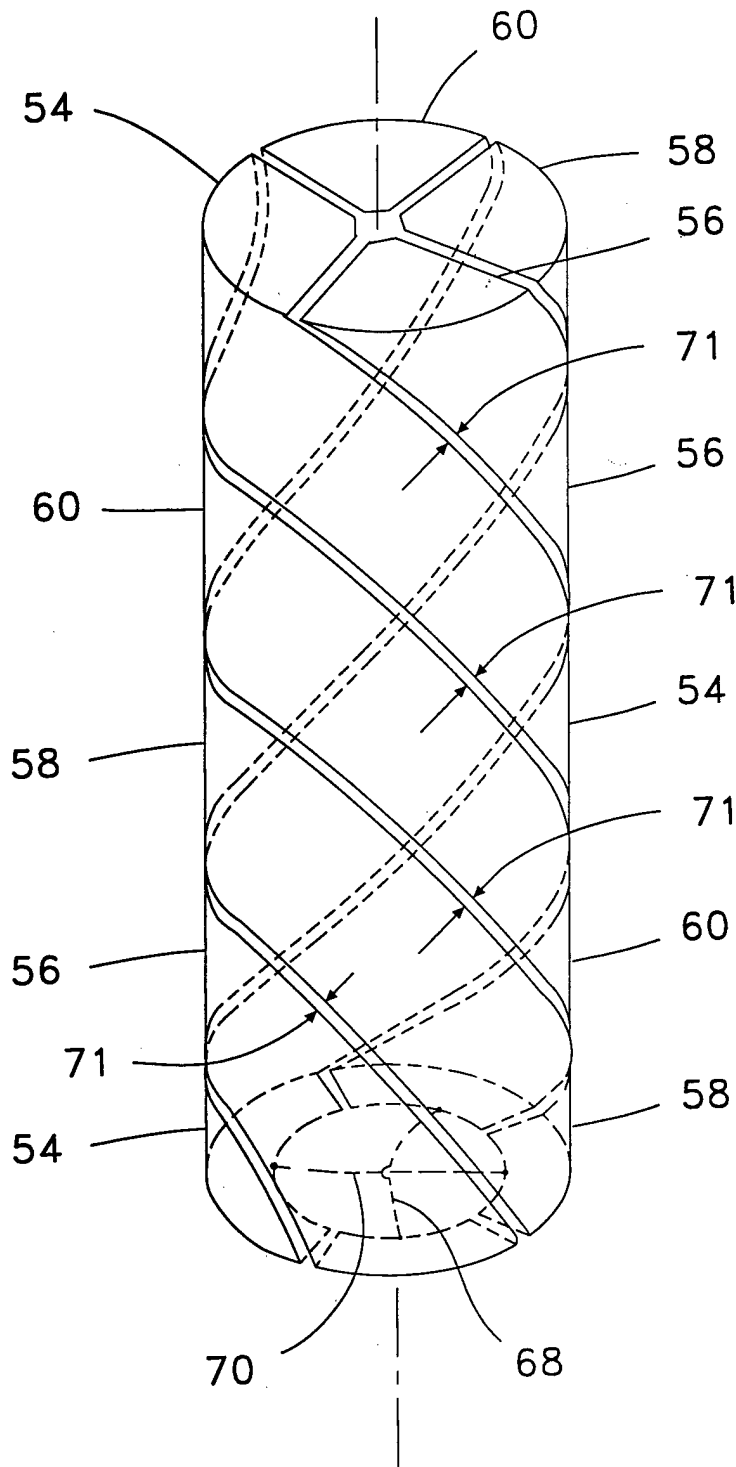

FIG. 2

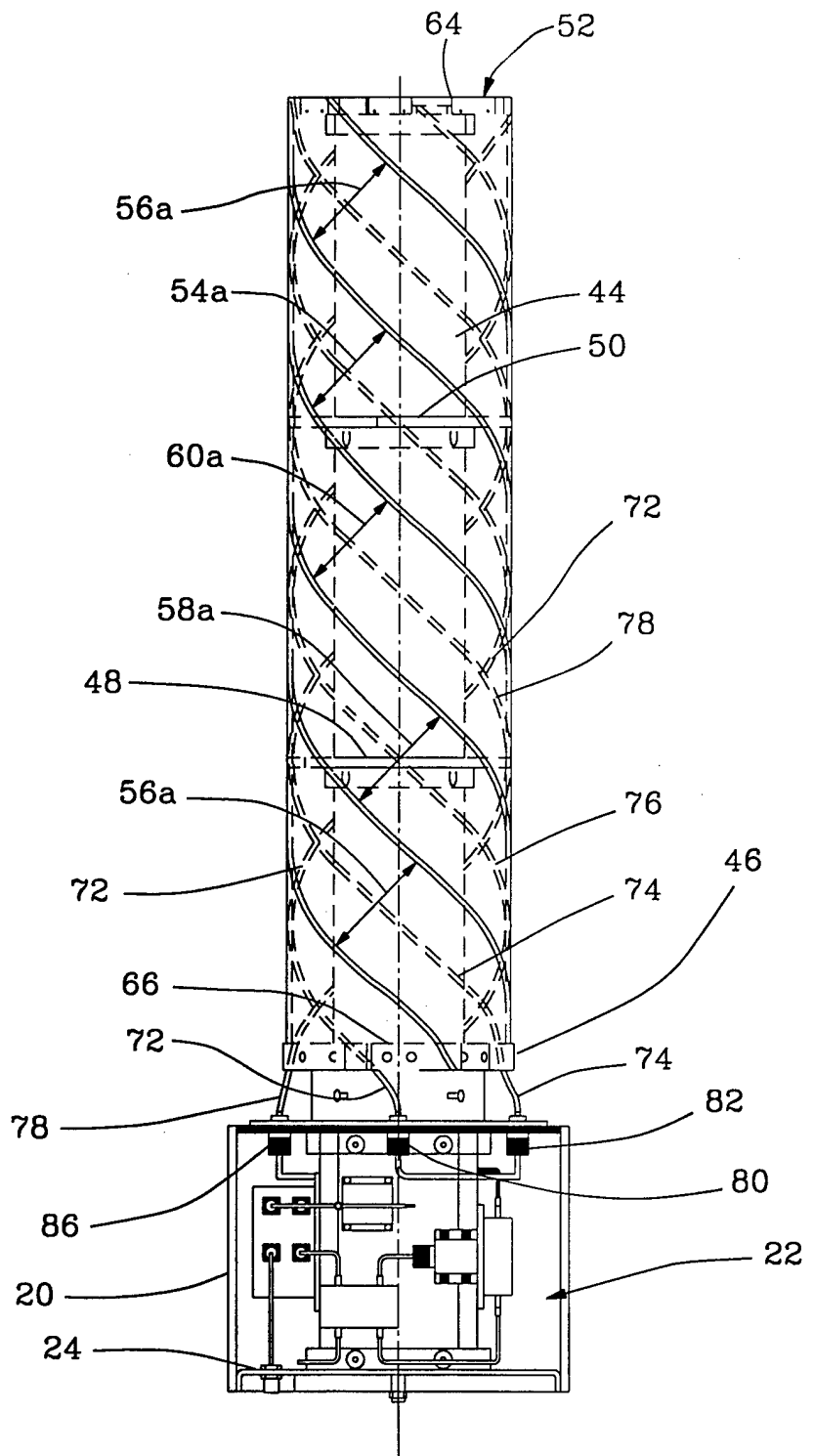

FIG. 3

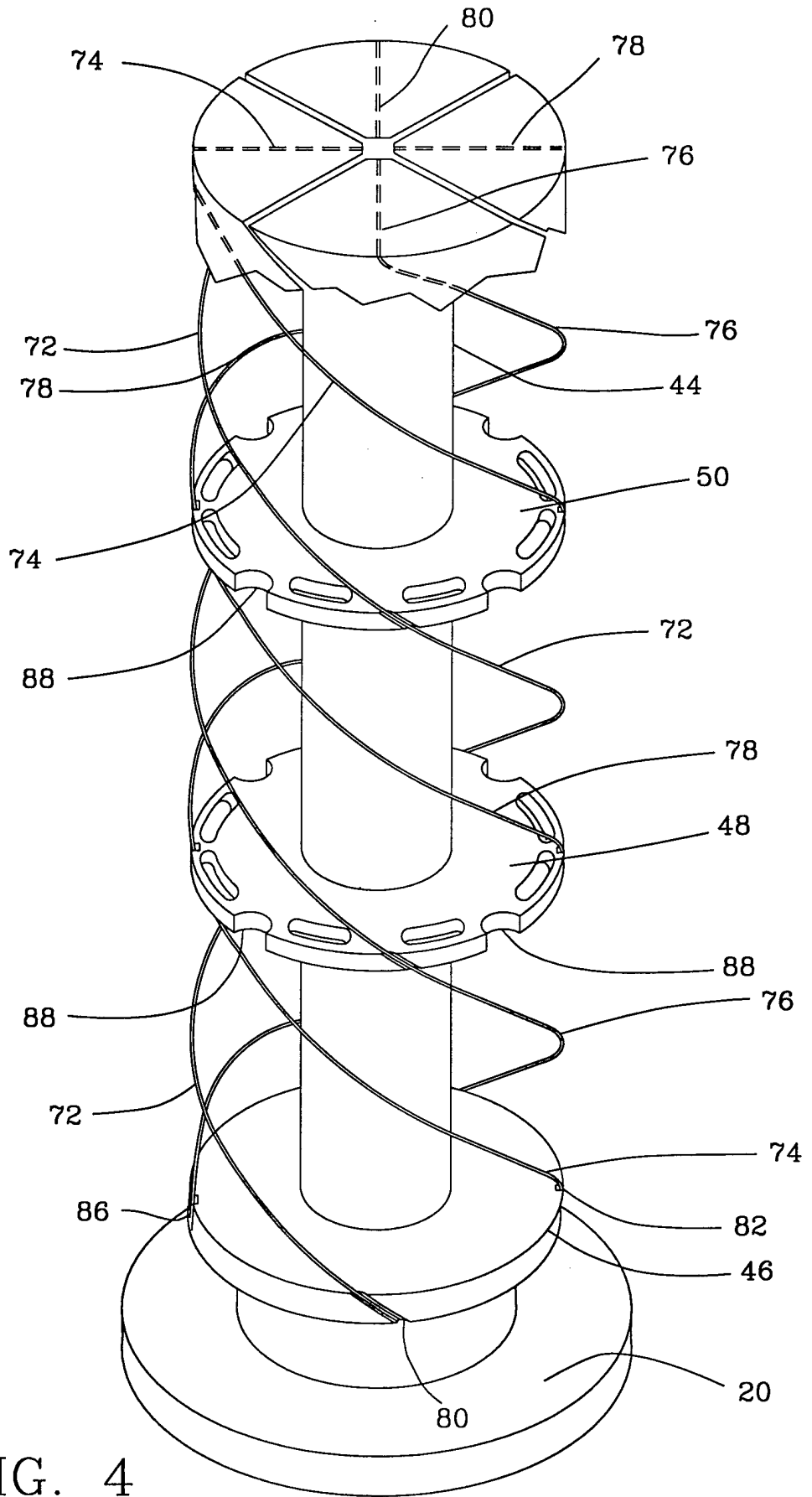

FIG. 4

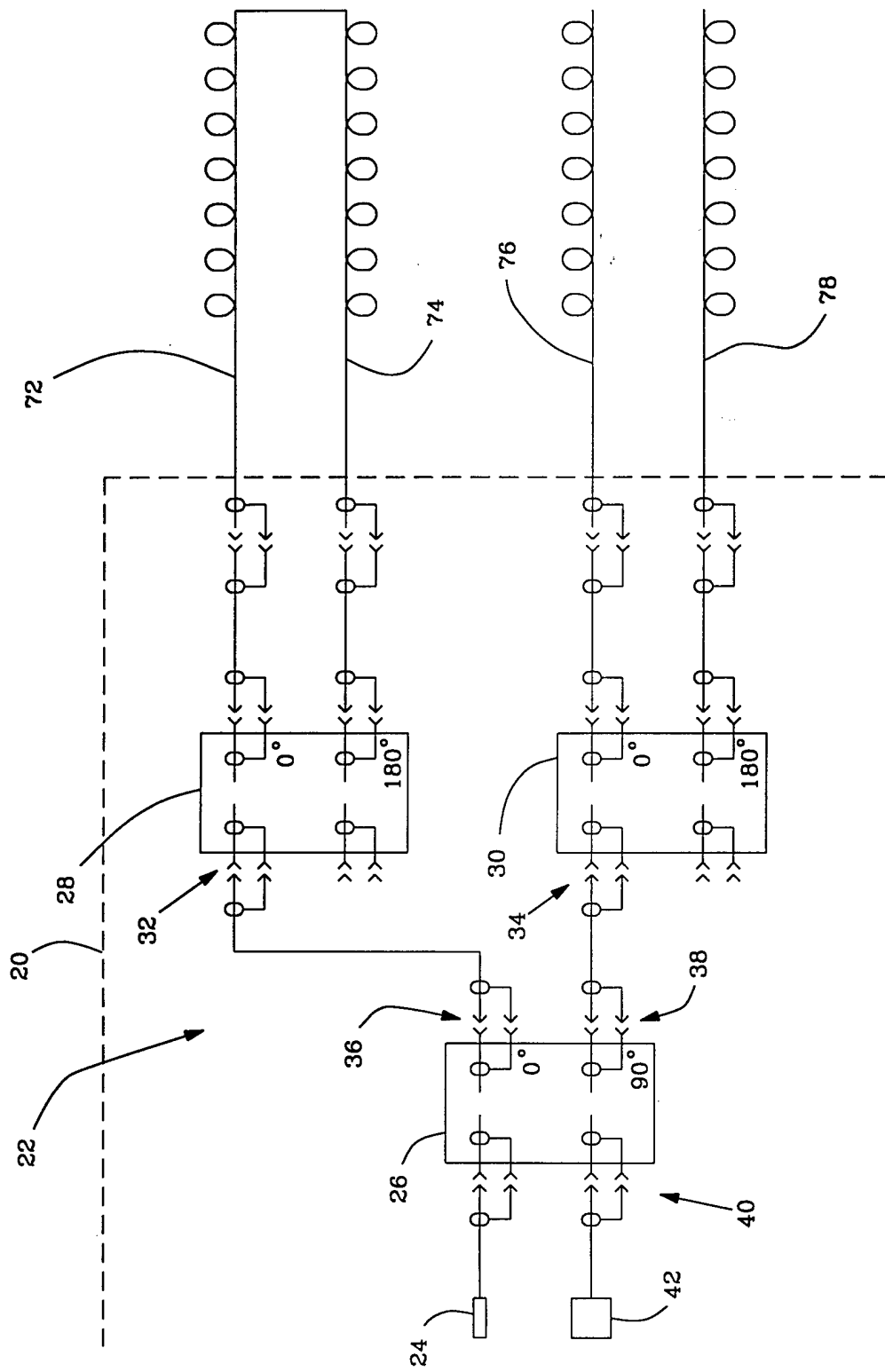

FIG. 5

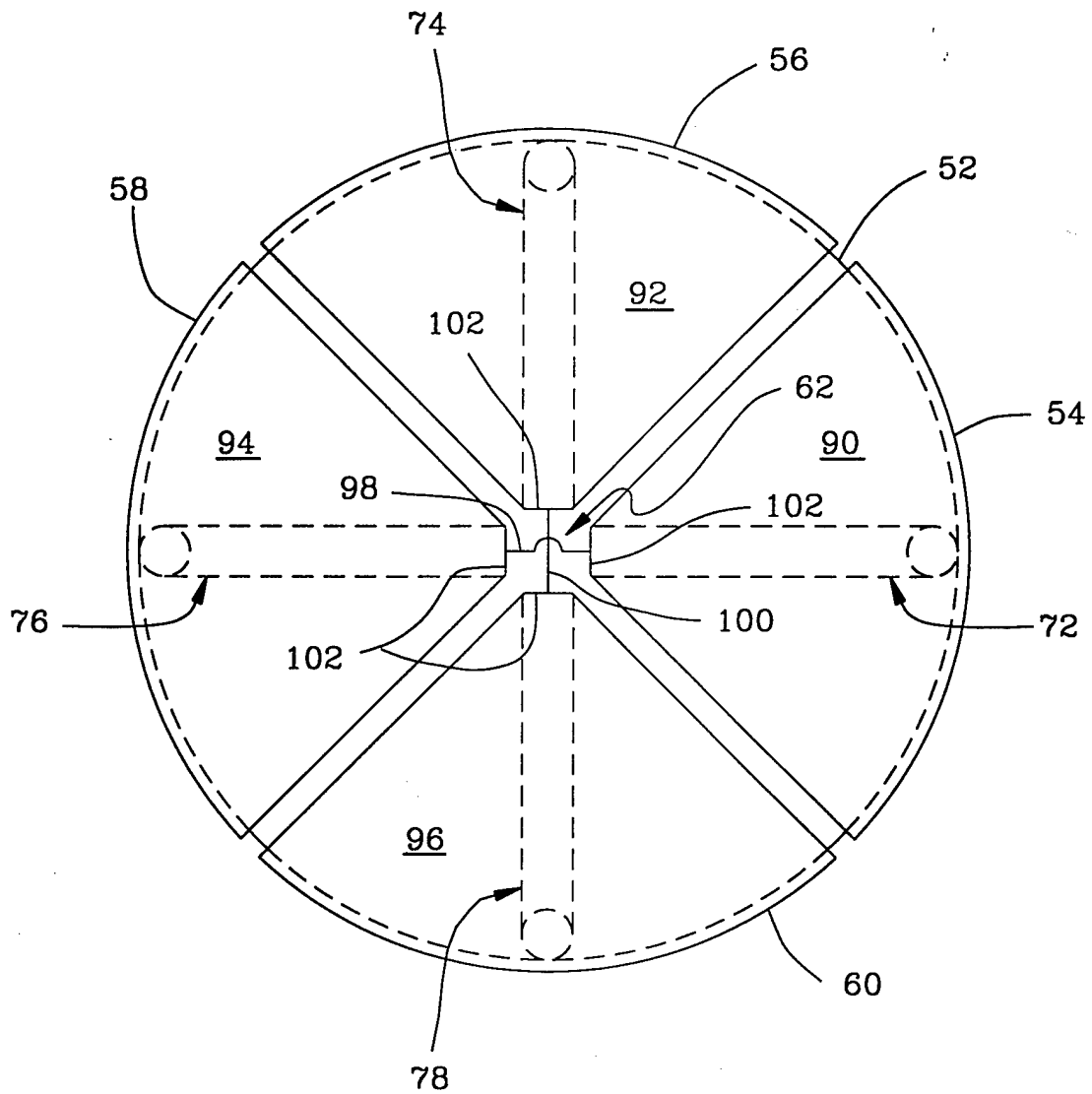

FIG. 6

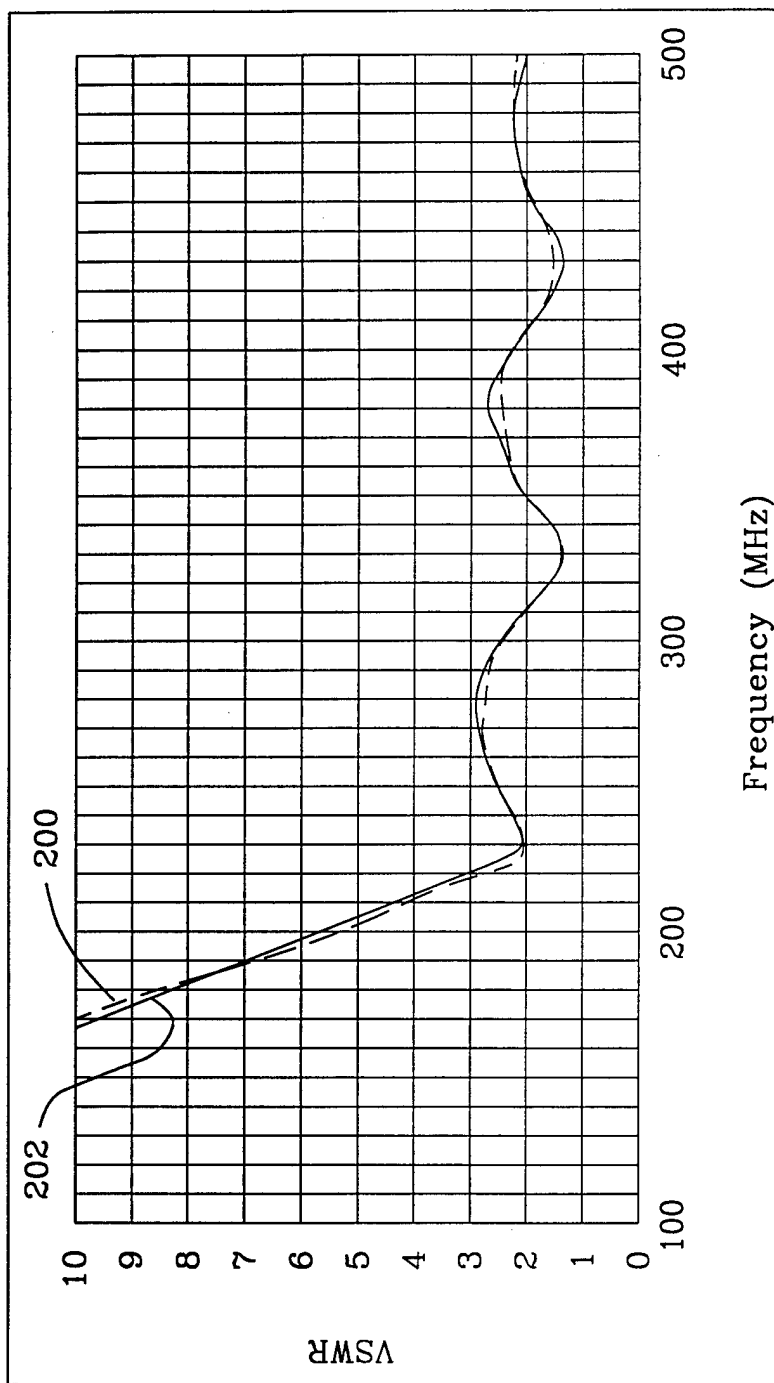
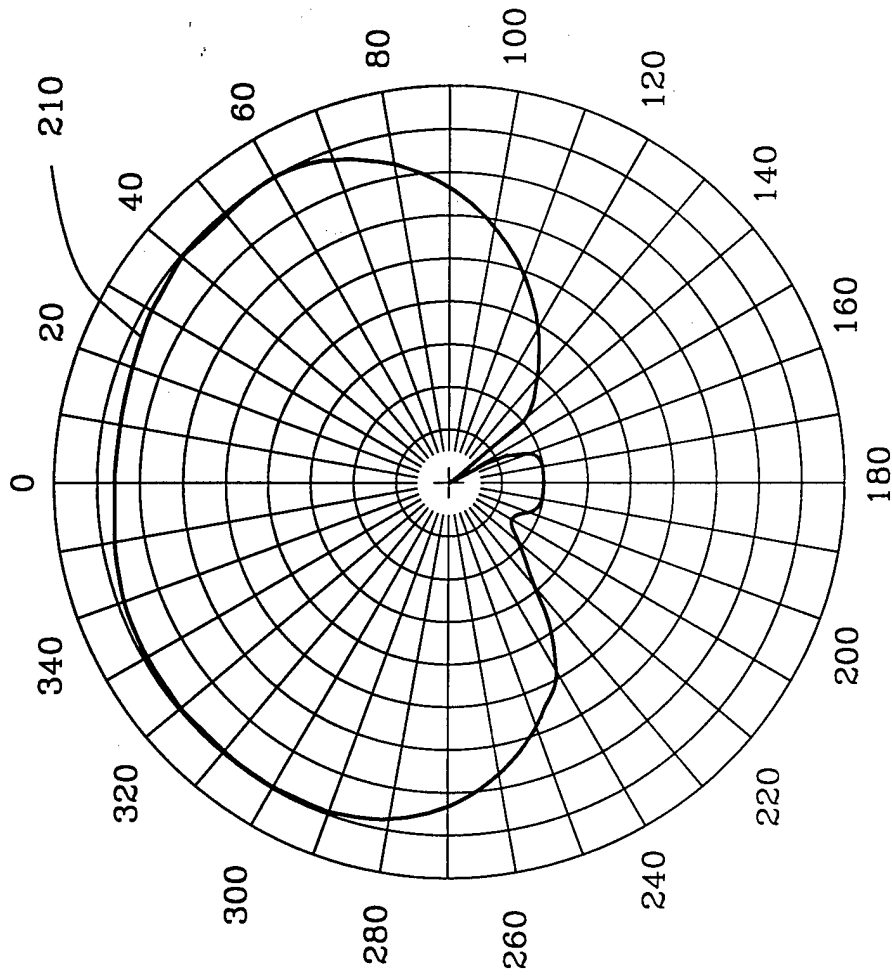

FIG. 7



Frequency (MHz): 280

FIG. 8