

Serial Number 09/477,149
Filing Date 4 January 2000
Inventor John F. Kunstmann

NOTICE

The above identified patent application is available for licensing. Requests for information should be addressed to:

OFFICE OF NAVAL RESEARCH
DEPARTMENT OF THE NAVY
CODE 00CC
ARLINGTON VA 22217-5660

DISTRIBUTION STATEMENT A
Approved for Public Release
Distribution Unlimited

20000223 073

ROCKET MOTOR WITH DESENSITIZER INJECTOROrigin of the Invention

The invention described herein was made in the performance of official duties by an employee of the Department of the Navy and may be manufactured, used, licensed by or for the Government for any governmental purpose without payment of any royalties thereon.

Field of the Invention

The invention described herein relates to solid fuel rocket motors and in particular to rocket motors having desensitizing safety features.

Background of the Invention

According to Military Standard 2105B, HAZARD ASSESSMENT TESTS FOR NON-NUCLEAR MUNITIONS, no munition which is subjected to a slow heating, referred to in the standard as "slow cook-off", may have a reaction greater than a Type V reaction. This reaction is described in the standard as follows: *"The energetic material ignites and burns non-propulsively. The case may open, melt or weaken sufficiently to rupture nonviolently, allowing mild release of combustion*

gases. Debris stays mainly within the area of the fire. This debris is not expected to cause fatal wounds to personnel or be hazardous fragment beyond 15 m (49 ft)." In the prior art, venting of various munitions has been accomplished by sealing the munition with a meltable material, such as nylon. Other mechanical venting methods are also known. For example, U.S. Patent 5,035,181, Tacks et al. describes a pop off for the fuze to lessen the cook-off hazard. Other types of munitions have used desensitizing fluids to inert a munition until a short time prior to arming. An example of such a munition is the small bagged packets of anti-personnel munitions which are carried in an aircraft canister filled with freon. Upon discharge from an aircraft, the small bags scatter around the target rapidly drying. Once dry, the munition is highly sensitive and will detonate upon any disturbance. Various venting, both mechanical and melting types have been applied to rocket motors. Likewise, various desensitizing means have been applied. However, no prior art method meets the Type V burning standard for slow cook-off of rocket motors. A need exists for a means of desensitizing a rocket motor fuel at the time of an inadvertent slow cook-off.

Summary of the Invention

Accordingly, it is an object of the invention to provide a solid fuel rocket motor having non-energetic burning characteristics when subjected to slow cook-off.

It is a further object of the invention to provide a solid fuel rocket motor that is ready to operate, but retains the insensitivity characteristics.

It is another object of the invention to provide a solid fuel rocket motor that is de-energized by a desensitizing fluid in the event of slow cook-off.

The invention is an enclosure that is connected via a tube to the interior of a solid fuel rocket motor. A plug made from a material having a low melting point seals the connecting tube between the enclosure and the interior of the solid fuel rocket motor. The melting point of the plug material is chosen so that it is below the expected cook-off temperature of the particular rocket. The enclosure has a fill port that is sealed by a cap. The enclosure contains a fluid that will desensitize the solid rocket fuel when the two materials come into contact. In normal storage, or in ready deployment, the desensitizing fluid within the enclosure is separated from the propellant charge and has no effect on the rocket motor. If, however, the rocket motor is subjected to

slow cook-off, the meltable plug melts, turning into a liquid. The liquefied plug, along with the desensitizing fluid is forced down the connecting tube and into the interior of the solid fuel rocket motor by pressure generated in the enclosure. The pressure in the enclosure is generated by the increased vapor pressure of the fluid at the elevated temperature of the slow cook-off. Alternately, compressed gas, a stretched elastic membrane or a spring driven piston may pressurize the desensitizing fluid. The desensitizing fluid contacts the solid rocket fuel, degrading its energetic qualities. When the cook-off temperature of the rocket is reached, the degraded propellant burns much more slowly, meeting the Type V burning requirement. During normal operation of the rocket motor the desensitizing fluid will not come into contact with the solid fuel. This is because there will not be enough time for the plug to melt during the function time of the rocket, and the pressure generated in the rocket motor will prevent any fluid flowing from the enclosure into the interior of the rocket motor.

Brief Description of the Drawings

The foregoing objects and other advantages of the present invention will be more fully understood from the following

detailed description and reference to the appended drawings wherein:

FIG. 1 is a side view of the rocket motor with the desensitizer showing a partial cross-section.

Detailed Description of the Invention

Referring now to FIG. 1, the rocket motor, designated generally by the reference numeral 10, is shown with its major components. The rocket motor comprises a case 12 containing a propellant 14. A bulkhead 16 is threaded to the case 12 forward of the propellant charge 14. The rearward or exhaust end of the rocket motor is to the right in the figure. An enclosure 18 is connected to the rocket motor 10 by a tube 20. Male threads on the end of the tube 20 mate with female threads in a port in the bulkhead 16. The end of the tube 20 passes through the bulkhead 16 and into the interior of the case 12. The tube 20 is sealed between the enclosure 18 and the interior of the case 12 by a plug 22. The plug 22 is made from a material having a melting point below the expected cook-off temperature of the propellant 14. The enclosure has a fill port 24 that is sealed by a cap 26. The enclosure contains a fluid 28 that is known to desensitize the propellant 14.

Operation of the invention occurs when the rocket motor is subjected to slow cook-off. The increased temperature causes an increase in the vapor pressure of the fluid 28, increasing the pressure inside the enclosure 18. At a temperature slightly below the cook-off temperature of the propellant 14, the heat sensitive plug 22 melts. Once the plug 22 has melted, the pressure inside the enclosure forces the liquefied plug 22 and the fluid 28 down the tube 20 and into the interior of the case 12. Once inside the case the fluid 28 contacts the propellant 14, desensitizing its energetic properties. Shortly thereafter (in a typical slow cook-off circumstance) the propellant 14 reaches cook-off temperature, but by that time the propellant has already been desensitized and the ignition and burning is greatly attenuated. No explosion can occur and the ensuing burning is non-energetic, not exceeding the specified Type V fire.

The features and advantages of the present invention are numerous. The rocket motor is fully active and ready for launch with the desensitizing assembly in place. Only in the event of a high temperature is the desensitizing fluid released. As a result, the safety feature is in place at all times and does not interfere with the normal function of the rocket. In the event of a slow cook-off environment, however,

the rocket propellant is desensitized immediately prior to cook-off temperature. The rocket motor, by this means safes itself only in the event of and just prior to a slow cook-off.

Numerous variations can be made within the scope of the invention. A bladder of elastomeric material or a spring driven piston may be used in the enclosure to provide increased evacuation of the desensitizing fluid. Additionally, variation may be made in the configuration and location of the tube. A valve activated by a heat sensitive element such as a bimetallic strip or a material such as Nitinol may replace the low melting point plug. Although the invention has been described relative to a specific embodiment thereof, there are numerous variations and modifications that will be readily apparent to those skilled in the art in the light of the above teachings. It is therefore to be understood that the invention may be practiced other than as specifically described.

ABSTRACT

A rocket motor having a desensitizing mechanism for preventing explosion or energetic burning during slowcook-off is provided. The rocket motor includes a case contained rocket propellant with a desensitizing assembly attached forward of the propellant charge. The desensitizing assembly is formed with an enclosure containing a desensitizing fluid, connected to the interior of the rocket motor by a tube which is sealed by a heat activated plug. The heat activated plug melts at a temperature below the slow cook-off temperature of the rocket propellant. The melting of the plug allows the desensitizing fluid to be injected into the core of the propellant thereby desensitizing the propellant.

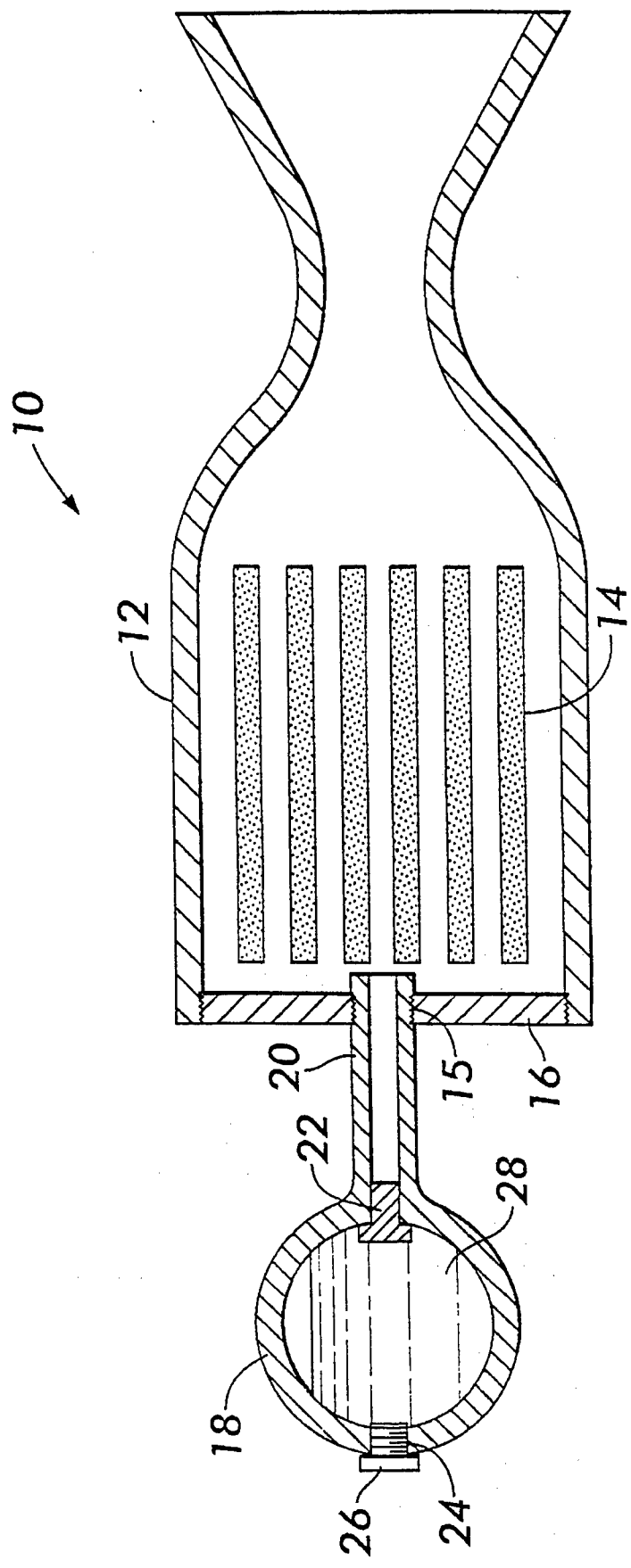

FIG. 1