

Serial Number 09/252,243
Filing Date 14 January 1999
Inventor David R. Costa
 Seth B. Suppappola

NOTICE

The above identified patent application is available for licensing. Requests for information should be addressed to:

OFFICE OF NAVAL RESEARCH
DEPARTMENT OF THE NAVY
CODE 00CC
ARLINGTON VA 22217-5660

19990708 053

DISTRIBUTION STATEMENT A
Approved for Public Release
Distribution Unlimited

2

3

POWER ENVELOPE SHAPER

4

5

STATEMENT OF GOVERNMENT INTEREST

6

7

8

9

The invention described herein may be manufactured and used by or for the Government of the United States of America for Governmental purposes without the payment of any royalties thereon or therefor.

10

11

BACKGROUND OF THE INVENTION

12

(1) Field of the Invention

13

14

15

The invention described herein relates to electronic circuits and their use in shaping power envelopes, and sonar systems making use of a shaped power envelope.

16

(2) Description of the Prior Art

17

18

19

20

21

22

23

24

25

It is known in the art to use pulsed (or gated) waveform in active sonar systems. These pulsed sonar systems may use signals that are continuous wave (CW), linear frequency modulated (LFM), stepped FM, etc. Often, two power levels are used: high power for long-range targets and low power for short-range targets. These predetermined power levels are used as the supply for the transmitter amplifier, which amplifies the gated signal and applies it to the transducer. Gating the transmit signal is equivalent to transmitting a signal with a square pulse envelope.

1 There are certain advantages, however, to transmitting a
2 signal with a nonsquare-shaped envelope. For example, in the case
3 of a gated sinusoid, the bandwidth of the transmitted signal is
4 actually the bandwidth of the square pulse (a sinc function, in
5 the frequency domain) centered about the frequency of the
6 sinusoid. This gating results in sidelobes in the spectrum that
7 are 13 dB down from the mainlobe. To reduce the sidelobes, it is
8 necessary to shape the envelope of the transmitted sinusoid. In
9 fact, sidelobes can be practically eliminated if a Gaussian-shaped
10 envelope is used, but only at the expense of a wider mainlobe.
11 Nevertheless, this condition may be desirable in certain
12 applications.

13 When using a nontrivial shape for the envelope of a
14 transmitted signal, signal generation becomes a more complex
15 process than simple gating. One approach uses a low-level digital
16 or analog electronics to generate the desired signal and its
17 envelope, which is then applied to a linear power amplifier for
18 application to the transducer. However, linear amplifiers are
19 large, expensive, and inefficient. This inefficiency results in
20 the internal dissipation of a considerable amount of power, which
21 leads to massive heat transfer issues.

22 A need exists for a device which can efficiently provide
23 control of a power envelope. Rapid switching, as well as low
24 power loss, is required in order to generate a shaped power
25 envelope efficiently.

1 SUMMARY OF THE INVENTION

2 It is an object of the invention to provide a power supply
3 system having a shaped power curve.

4 It is a further object of the invention to provide a low
5 power loss shaper for generating a signal.

6 It is a further object of the invention to provide a power
7 envelope-shaping module, which may be adapted to existing sonar
8 systems.

9 It is another object of the invention to provide a sonar
10 system having a power envelope shaper using output transistors in
11 two discrete states, either saturated or cut off.

12 Accordingly, the invention is a power envelope shaping device
13 for joining to a serial control output. The device includes a
14 power select circuitry module joined to the serial output.
15 Multiple power switcher modules are joined to a plurality of
16 incremental power sources and controlled by the power select
17 circuitry module. In this way, each power switcher module can
18 provide power from at least one of the incremental power sources
19 on command from said power select circuitry module. The power
20 switcher module outputs are joined together in order for
21 providing varying power levels in accordance with a preprogrammed
22 power envelope shape.

23 In a further embodiment, there is provided a sonar system
24 comprising a computer for system control, a power envelope shaper,
25 a transmitter module, and a transducer array. The power envelope
26 shaper is comprised of three components, the power select

1 . circuitry module, the power switcher module, and the battery pack.
2 The power envelope shaper receives control signals from the system
3 computer. These control signals, serial data and data clock, are
4 processed by a power level decoder, which enables a selected
5 output channel at the appropriate time. Each power switcher
6 channel controls a single tap of the battery pack by enabling and
7 disabling its output. If two or more taps are enabled at the same
8 time, the highest voltage will prevail. The output power from the
9 power switcher is fed directly to a sonar transmitter and controls
10 the amplitude of the acoustic sonar signal. The topside computer
11 provides the serial data control signals to the power switcher,
12 using fast switching speeds throughout a plurality of channels,
13 thereby allowing for the production of different sonar envelope
14 shapes. The device as configured produces a Gaussian-shape with
15 reduced side lobes.

16
17 BRIEF DESCRIPTION OF THE DRAWINGS

18 The foregoing objects and other advantages of the present
19 invention will be more fully understood from the following
20 detailed description and reference to the appended drawings
21 wherein:

22 FIG. 1 is a block diagram of the sonar system with a power
23 envelope shaper.

24 FIG. 2 is a block diagram depicting a single output channel
25 of the power switcher.

1 FIG. 3 is a block diagram of the complete power switcher
2 circuit.

3 FIG. 4 is a graph depicting a Gaussian-shaped sonar pulse
4 produced by the system.

5
6 DESCRIPTION OF THE PREFERRED EMBODIMENTS

7 Referring now to FIG. 1, the sonar system, designated
8 generally by the reference numeral 10, is depicted in a block
9 diagram showing its major components. A topside computer 12
10 controls the system by underwater cable 14 that is connected to
11 the power envelope shaper module 16, the shaped power envelope 18
12 is outputted to the sonar transmitter 20 which, in turn, powers
13 the transducer array 22. The result is a shaped sonar signal 24
14 having particular characteristics, such as reduced sidelobes,
15 depending on the transmitted shape. The transmitted shape is
16 determined by the power select circuitry 26 and the power
17 switcher 28 located within the power envelope shaper 18. A
18 multi-tap battery pack 30 provides power to the power switcher 28
19 to form the power envelope shape. The power envelope shaper 16
20 may be used with an existing sonar transmitter and transducer
21 array to form a sonar signal envelope shaper. The power envelope
22 shaper 16 is a self-contained, high speed, high power, efficient,
23 power amplitude shaping device. The topside computer 12
24 digitally controls the power envelope shaper which outputs a
25 preprogrammed arbitrary power envelope. This computer is
26 preferably built on a VersaModule Eurocard (VME) chassis having a

1 . serial output port; however, other commonly available computers
2 can be used.

3 The power envelope shaper can be used by existing sonar
4 transmitters and arrays to produce a shaped sonar waveform. The
5 transmitter and transducer package in the preferred embodiment
6 has a common ground wired to the case in several locations,
7 thereby requiring the use of a high-side driver for the power
8 switcher. A high-side driver is one in which the supply power is
9 switched before reaching the load, whereas, a low-side driver is
10 one in which the supply power is switched between the load and
11 the supply ground.

12 A more detailed view of the power envelope shaper 16 may be
13 seen in FIG. 2, which shows a single channel 80 of the multiple
14 channel power envelope shaper 16. A TTL and Complimentary Metal
15 Oxide Semiconductor (CMOS)-compatible MOS gate driver 32 used to
16 switch the power-gating device 34. As discussed previously, MOS
17 gate driver 32 must be a high side driver. Accordingly, gate
18 driver 32 provides a differential output voltage. Gate driver 32
19 must also provide high input and output currents in order to turn
20 power-gating device 34 on and off because of the high capacitance
21 of the power-gating device 34. MOS gate driver 32 is preferably
22 an International Rectifier IR2125™. Gate driver 32 uses a
23 bootstrap or floating supply technique in which capacitor 36 is
24 charged through diode 38 and keeps the power gating device 34 gate
25 fifteen volts above the emitter voltage when the power gating
26 device 34 is on. This floating supply technique is well known and

1 . widely used and is very effective in high-side switching designs.
2 Diode 38 is a fast recovery diode, so that capacitor 36 does not
3 discharge. Capacitors 40 and 42 are bypass capacitors required to
4 supply the transient current needed for refreshing the bootstrap
5 supply. Capacitor 44 is a despiking capacitor used to suppress
6 switching transients when the error output of gate driver 32 is
7 not used. Diode 72 and diode 48 are fast turn-on diodes that
8 protect the gate driver 32 by suppressing negative voltage
9 transients. These voltage transients are caused by flyback
10 current that is produced when switching an inductive load. The
11 voltage V across an inductor L follows the relation:

$$12 \quad V = L \frac{di}{dt} \quad (1)$$

13 where di/dt is the time derivative of current flow through the
14 inductor.

15 In this circuit, flyback current flows from ground 50 back to
16 the high power supply, VIN 52, when the power gating device 34
17 turns off. This negative traveling current causes large negative
18 voltage spikes. The metal oxide varistor (MOV) 54 and diode 56
19 protect the power gating device 34 collector-emitter junction from
20 inductive flyback, in the same way that varistor 58 protects the
21 gate-emitter junction. Zener diode 60 clamps positive transients
22 above the Zener breakdown voltage of 5.1 V. Resistor 62 and
23 resistor 64 limit the switching speed of the power gating device
24 34, resulting in slower turn-on and turn-off. This also results
25 in a decrease in unwanted flyback, because di/dt in equation (1)

1 is reduced. Resistance of resistors 62 and 64 can be decreased if
2 faster switching is required, but only at the expense of larger
3 flyback transients. The fast turn-on diode 66 helps clamp
4 negative voltage transients at the power gating device's emitter.
5 Capacitor 68 is the bypass capacitor for the high-power supply.
6 Diode 70 isolates each battery output from the others, while a
7 fast turn-on diode 73, isolates each switching block from the
8 others. The diode 73 is necessary so that the outputs of each
9 switching block can be hard-wired together. In this
10 configuration, the highest enabled output 74 will prevail.
11 Power-gating device 34 must have a rise time of at most 49 ns and
12 a fall time of at most 410 ns. An insulated gate bipolar
13 transistor (IGBT) with high-power capabilities and a typical turn-
14 on time of 43 nanoseconds was selected to fulfill these
15 requirements for the power-gating device 34. MOSFET circuitry
16 was initially tried for the power gating device 34, but the
17 circuitry was unable to handle the high current requirements.
18 The insulated gate bipolar transistor is preferably an
19 International Rectifier IRGPC50F™. Each power switcher channel
20 is capable of 70 Amperes of continuous current, a 600V breakdown
21 voltage, and a maximum internal power dissipation of 200 Watts.
22 High efficiency and a small package size are made possible because
23 the IGBTs are operated in either the saturation or cutoff region.
24 The operation allows for a minimal internal power dissipation and
25 necessitates only small heat sinks. In the preferred embodiment,

1 a TO-247 heat sink with one-inch fins was used to dissipate heat
2 from the power-gating device 34.

3 The complete power envelope shaper is shown in FIG. 3
4 including the field programmable gate array (FPGA)-based power
5 level decoder (power select circuit 26), multi-tap battery pack
6 30, and each power-switcher channel 80. (For clarity only part of
7 the channels and battery numerals are shown, each repeating in the
8 array.) The control signals, serial data 82 and data clock 84 are
9 processed by the power level decoder 26 which enables each power
10 switcher channel 80 at the appropriate time. Each power switcher
11 channel 80 controls a single tap of the battery pack 30 by
12 enabling and disabling its output. A power envelope is produced
13 by switching each battery tap at the appropriate time to generate
14 the desired power waveform. The output power 86 from the power
15 switcher 80 is fed directly to a sonar transmitter and controls
16 the amplitude of the acoustic sonar signal. The desired sonar
17 signal shape for this application was a Gaussian envelope,
18 although the envelope shaper is versatile enough to produce an
19 envelope of arbitrary shape.

20 FIG. 4 shows the Gaussian acoustic sonar signal that was
21 produced. The shape and duration of the pulsed signal is
22 digitally controlled by topside computer 12, which transmits a
23 serial digital word via an underwater cable to a wet-side power
24 level decoder 26. The serial word is decoded by an FPGA-based
25 power level decoder, which generates the eleven enable signals
26 that control each power switcher 80. To produce a Gaussian

1 envelope, the eleven discrete power levels were enabled
2 sequentially and then disabled in a descending order. The
3 transmitter uses this power to produce a pulsed sonar signal
4 resulting in the Gaussian envelope 88.

5 The features and advantages of the invention are numerous.
6 The computer control allows for fast switching speeds and the
7 generation of virtually any power envelope shape. The power
8 envelope shaper described above was developed as a separate
9 underwater module, which may be used with an existing sonar
10 transmitter in order to shape the envelope of a pulsed sonar
11 signal. The use of discrete states wherein transistors operate
12 only in the saturated or cut-off modes provide high efficiencies
13 and minimum internal heat generation.

14 It will be understood that many additional changes in the
15 details, materials, steps and arrangement of parts, which have
16 been herein described and illustrated in order to explain the
17 nature of the invention, may be made by those skilled in the art
18 within the principle and scope of the invention.

19

2

3

POWER ENVELOPE SHAPER

4

5

ABSTRACT OF THE DISCLOSURE

6 A power envelope shaping device for joining to a serial
7 control output is disclosed. Multiple power switcher modules are
8 joined to a plurality of incremental power sources and controlled
9 by the power select circuitry module. In this way, each power
10 switcher module can provide power from at least one of the
11 incremental power sources on command from said power select
12 circuitry module. The power switcher module outputs are joined
13 together in order for providing varying power levels in
14 accordance with a preprogrammed power envelope shape.

15 In a further embodiment, there is provided a sonar system
16 comprising a computer for system control, a power envelope shaper,
17 a transmitter module, and a transducer array. The power envelope
18 shaper receives control signals from the system computer. These
19 control signals, serial data and data clock, are processed by a
20 power level decoder, which enables a selected output channel at
21 the appropriate time. Each power switcher channel controls a
22 single tap of the battery pack by enabling and disabling its
23 output. The output power from the power switcher is fed directly
24 to a sonar transmitter and controls the amplitude of the acoustic
25 sonar signal. The computer provides the serial data control
26 signals to the power switcher, using fast switching speeds thereby

- 1 . allowing for the production of different sonar envelope shapes.
- 2 The particular envelope shape may be immediately modified by
- 3 software to produce Gaussian or other power envelope shapes.

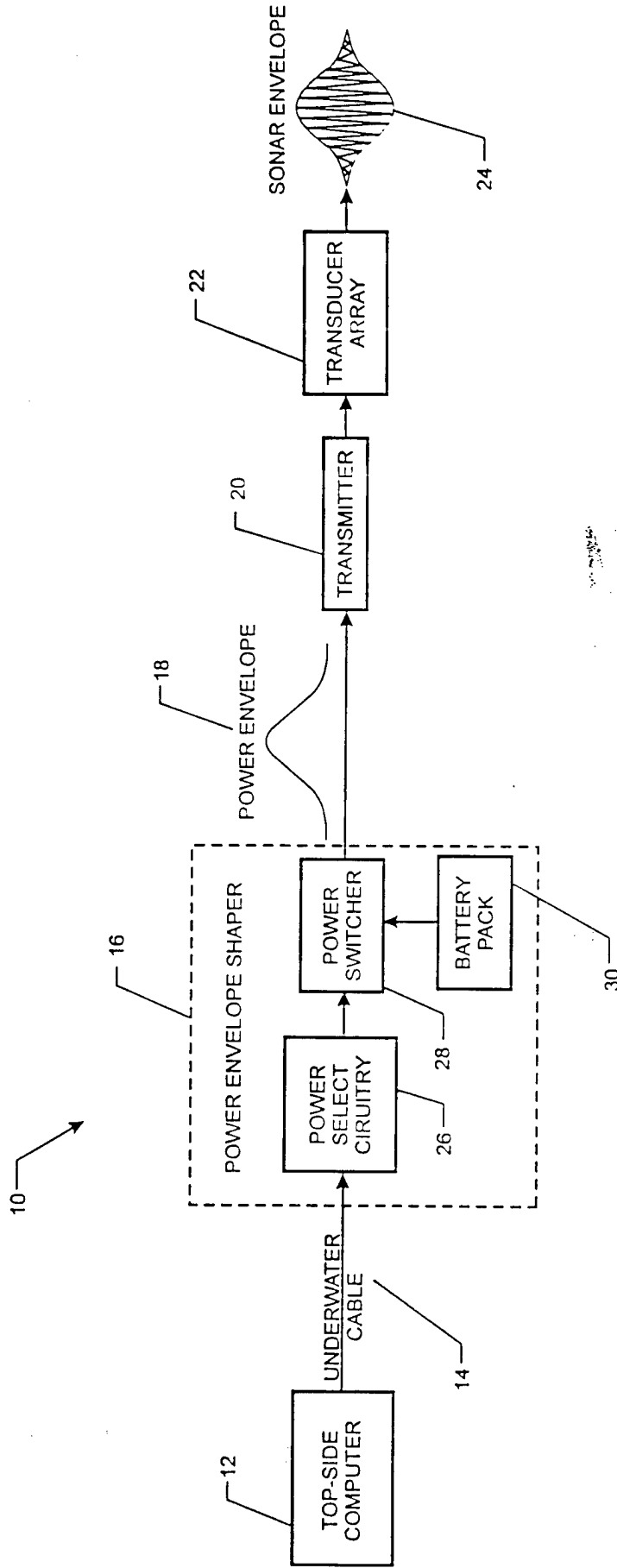

FIG. 1

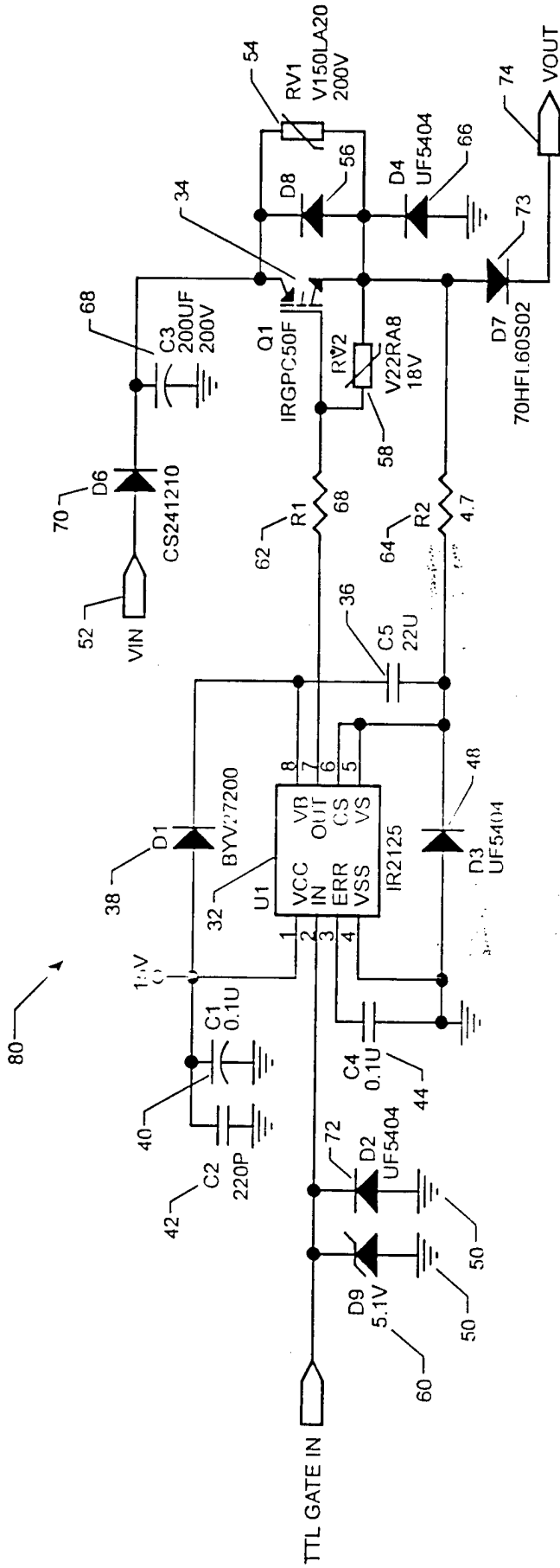

FIG. 2

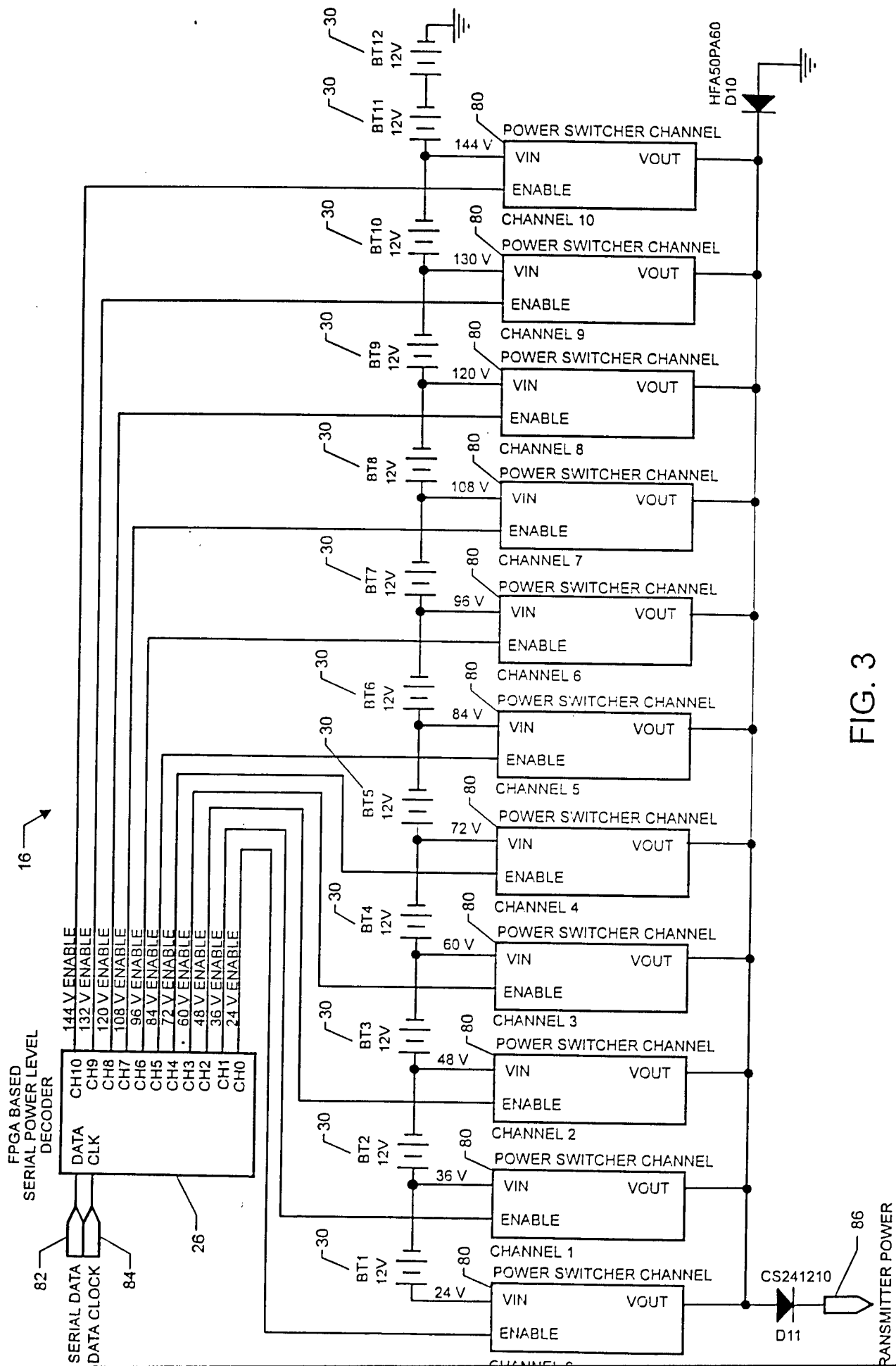

FIG. 3

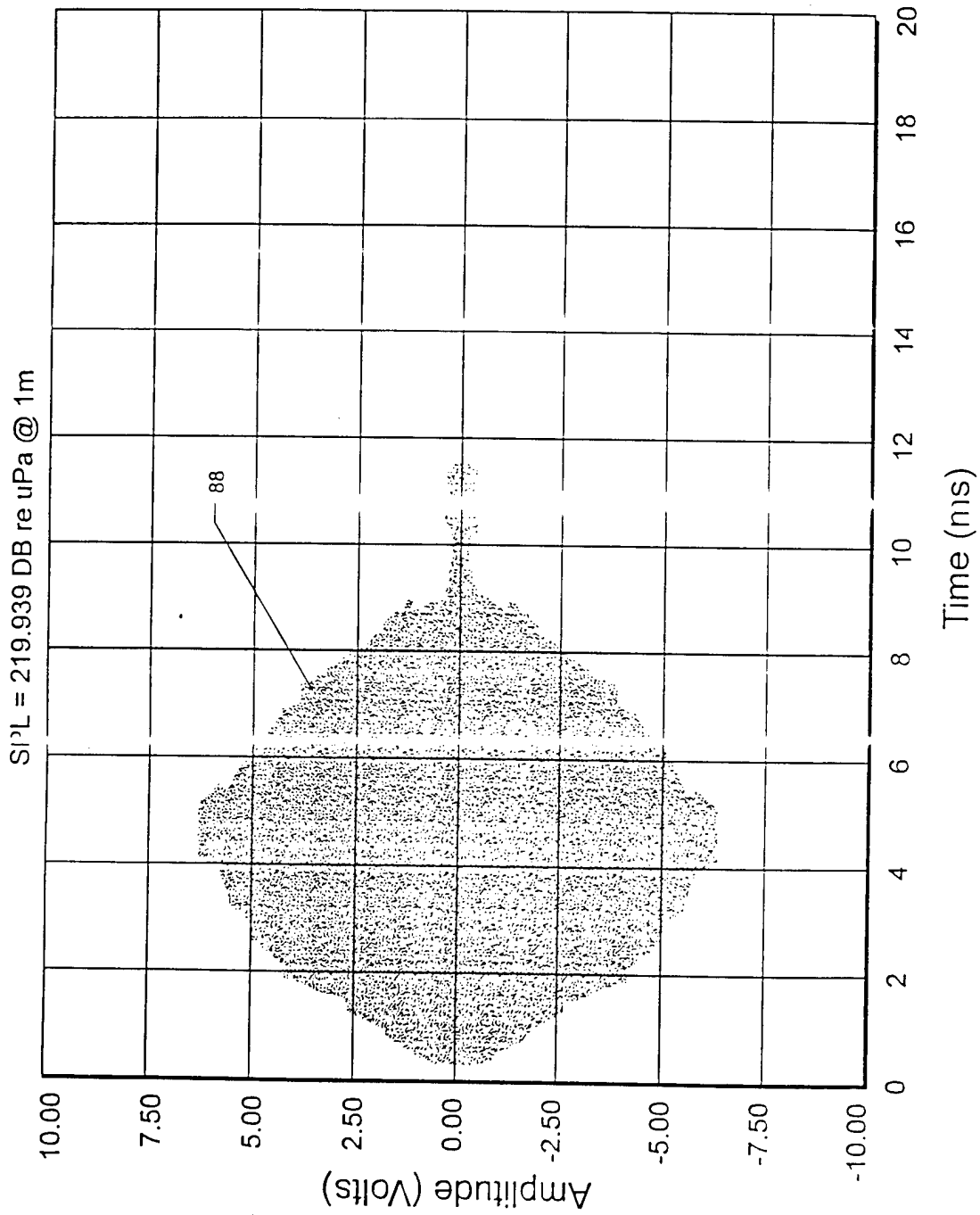

FIG. 1