

Serial Number 877,880
Filing Date 18 June 1997
Inventor Donald U. Gubser
 M. S. Imam

NOTICE

The above identified patent application is available for licensing. Requests for information should be addressed to:

OFFICE OF NAVAL RESEARCH
DEPARTMENT OF THE NAVY
CODE OCCC
ARLINGTON VA 22217-5660

DISTRIBUTION STATEMENT A
Approved for public release;
Distribution Unlimited

19980120 119

DTIC QUALITY INSPECTED 3

1
2
3 HIGH TEMPERATURE SUPERCONDUCTING CERAMIC OXIDE COMPOSITE WITH
4 RETICULATED METAL FOAM
5

6 **Background of the Invention**

7 **1. Field of the Invention**

8 The invention relates to high temperature superconducting composite materials, and more
9 particularly to a high temperature superconducting composite material made by filling the open
10 cells of a silver, silver alloy, gold or gold alloy foam with a high temperature superconducting
11 ceramic oxide.

12 **2. Description of the Related Art.**

13 Superconducting ceramic oxides with critical temperatures that exceed the temperature of
14 liquid nitrogen have been developed in recent years. However, the full potential of these materials
15 for transporting power or generating magnetic fields has not been realized because the ceramic
16 oxides are hard, brittle and difficult to form in proper geometries (wires, rods or tapes) with the
17 requisite composition and structural orientation.

18 Superconducting rods, wires or tapes may be fabricated by packing the ceramic oxide
19 powder into a metal tube and then drawing the tube into a wire or rod or flattening it into a tape.
20 Methods of making single strand conductors are disclosed in U.S. Patent No. 4,980,964 to Boeke
21 and U.S. Patent No. 5,206,211 to Meyer. To create a multifilamentary conductor for use in

1 magnets, the wire can be rebundled and then redrawn or rolled into a tape. A method of
2 fabricating superconducting ceramic tape is to coat the ceramic onto one or both sides of a metal
3 tape. Various other geometric configurations for superconducting wire with multiple filaments
4 are disclosed in U.S. Patent No. 4,929,596 to Meyer et al, U. S. Patent No. 4,849,288 to
5 Schmaderer et al, U.S. Patent No. 5,374,612 to Ito et al, U.S. Patent No. 5,017,553 to Whitlow
6 et al and U.S. Patent No. 5,347,085 to Kikuchi et al. Conductors as described above are limited
7 in their current carrying capacity because individual superconducting filaments are subject to
8 material inhomogeneities.

9 Other approaches to reinforcing superconducting ceramics, making them stronger and
10 easier to fabricate, are to disperse metal particles throughout a superconducting matrix or to
11 disperse superconducting ceramic particles throughout a metal matrix. U.S. Patent No. 5,082,826
12 to Ferrando discloses a superconducting ceramic powder in which powder particles are coated
13 with silver. U.S. Patent No. 4,983,574 to Meyer describes a conductor having particles of ceramic
14 sintered high-temperature superconductor embedded in a metal matrix. U.S. Patent No. 5,306,704
15 to Gleixner et al discloses a method of dispersing a metal homogeneously throughout a
16 superconducting material by blending the metal and a superconducting oxide, melting the blend
17 and blowing the blend to form glassy filaments. Superconducting materials as described above
18 contain either discontinuous ceramic oxide particles or discontinuous metal particles. The
19 dispersion of metal throughout a ceramic matrix or the dispersion of ceramic throughout a metal
20 matrix provides improved strength and flexibility, but results in poorer superconducting properties
21 and thermal stability. U.S. Patent No. 5,470,821 to Wong et al describes a bulk composite

1 superconducting material made by combining ceramic oxide and metallic particulates. The
2 composite is compressed so that the metallic material fills the interstices between the ceramic
3 oxide particles.

4

5

Summary of the Invention

6

It is an object of the invention to provide a high temperature superconducting ceramic
7 oxide composite with a high current carrying capacity.

8

It is a further object of the invention to provide a high temperature superconducting
9 ceramic oxide composite that is mechanically strong.

10

It is a further object of the invention to provide a high temperature superconducting
11 ceramic oxide composite that has a large interface area with silver, silver alloy, gold or gold alloy
12 uniformly spaced throughout the composite.

13

It is a further object of the invention to provide a high temperature superconducting
14 ceramic oxide composite that allows for rapid and uniform oxygenation of the superconducting
15 ceramic oxide.

16

It is a further object of the invention to provide a high temperature superconducting
17 ceramic oxide composite that provides high thermal conductivity to minimize the development
18 of hot spots during operation as a superconductor.

19

It is a further object of the invention to provide a high temperature superconducting
20 ceramic oxide composite that is easy and inexpensive to fabricate.

21

These and other objects are accomplished by a method of making a high temperature

Inventor's Name: Donald U. Gubser and M. Ashraf Imam

1 superconducting composite comprising the steps of providing a reticulated foam structure made
2 of a metal selected from the group consisting of silver, silver alloy, gold and gold alloy, the
3 reticulated foam structure having continuous ligaments defining a plurality of continuous open
4 cells, filling the continuous open cells of the reticulated foam structure with a high temperature
5 superconducting ceramic oxide or precursor, compacting the filled structure, and heating the
6 compacted structure to melt and/or texture the high temperature superconducting ceramic oxide
7 or precursor to form a continuous region of high temperature superconducting ceramic oxide
8 throughout the compacted reticulated foam structure. Making a composite by the method outlined
9 above results in a composite that is mechanically strong, and has a large interface area between
10 the superconducting ceramic oxide and the metal, which allows a uniform current flow and a high
11 current density. Since oxygen diffuses more rapidly through the metals listed above than it does
12 through a ceramic oxide, the large interface area allows for more rapid and more homogeneous
13 oxygenation. Because the metals are more thermally conductive than ceramic oxide, the thermal
14 stability of the superconducting ceramic oxide is enhanced.

15 **Brief Description of the Drawings**

16 Figure 1 is a diagrammatic, perspective view partly in section of a superconducting wire
17 of the present invention.

18 Figure 2 is a diagrammatic, perspective view partly in section of a second embodiment
19 of a superconducting wire of the present invention.

20 Figure 3 is a plot of voltage, V vs. current, I , of a high temperature superconducting rod
21 with a cross-sectional area of 0.0616 cm^2 .

Detailed Description of the Preferred Embodiments

1
2 The present invention is a method of making a high temperature superconducting ceramic
3 oxide composite by filling the open cells of a reticulated silver, silver alloy, gold or gold alloy
4 foam structure with a superconducting ceramic oxide or precursor and then compacting and
5 heating the structure to make a composite that has a continuous region of high temperature
6 superconducting ceramic oxide interlaced throughout the compacted reticulated metal foam.

7 The reticulated foam structure can be any structure that has a plurality of continuous
8 cross-linked ligaments or filaments that define a plurality of continuously connected open cells
9 that can be filled with a superconducting ceramic oxide. As used herein, the term "open cells"
10 refers to the open spaces between or among cross-linked ligaments or filaments. The criterion for
11 selecting a preferred reticulated foam structure for the invention is to provide a structure that,
12 when the open spaces are filled with a superconducting material, will have a large interface area
13 between the structural material (the metal foam) and the superconducting material (the ceramic
14 oxide) while providing both continuous ligaments of the structural material and a continuous
15 region of superconducting material. While the invention is not limited to these embodiments,
16 examples of reticulated foam structures having suitable geometry for the practice of the invention
17 are described in U.S. Patent No. 3,616,841 to Walz and U.S. Patent No. 3,946,039 to Walz, and
18 U.S. Patent No. 4,235,277 to Aizawa, the disclosures of which are hereby incorporated by
19 reference. Also, reticulated foam materials are fabricated by Energy Research and Generation, Inc.
20 of Oakland, Ca. under the trademark Duocel[®].

21 Reticulated foam structures are typically defined in terms of the relative density of the

1 foam structure as compared to the density of the bulk material of the same composition.
2 Preferably, the reticulated foam structure of the present invention (before filling with the
3 superconducting ceramic oxide) will have a relative density of from about 5 % to about 55 % of
4 that of the bulk material. Most preferably, the reticulated foam structure will have a relative
5 density of from about 10 % to about 30 % of that of the bulk material. Another typical way of
6 defining the geometry of a foam structure is in terms of pores per inch. Preferably, the reticulated
7 foam structure of the present invention will have from about 5 to about 80 pores per inch.

8 The reticulated foam structure is preferably made of silver, silver alloy, gold or gold alloy.
9 Because the preparation of the superconducting composite requires a heating step to melt and/or
10 texture the superconducting ceramic or precursor at a temperature, which, for particular ceramic
11 oxides, may be above the melting temperature of pure silver, it is preferred that a silver alloy
12 selected to have a melting temperature above the melting and/or texturing temperature of the
13 particular ceramic oxide be used in the practice of the invention. Preferably, the silver alloy is
14 a silver-palladium alloy that is at least 80 % silver, more preferably at least 90 % silver by
15 weight.

16 Any high temperature superconducting ceramic oxide may be used in the practice of the
17 invention. A high temperature superconducting ceramic oxide is typically defined as a ceramic
18 oxide superconductor that has an onset or critical temperature (T_c) above the temperature of liquid
19 nitrogen. Preferably, the high temperature superconducting ceramic oxide is selected from the
20 group consisting of bismuth - based superconducting ceramic oxides, thallium - based
21 superconducting ceramic oxides, yttrium - based superconducting ceramic oxides, and mercury -

Inventor's Name: Donald U. Gubser and M. Ashraf Imam

1 based superconducting ceramic oxides. Most preferably, the high temperature superconducting
2 ceramic oxide is selected from the group consisting of $\text{Bi}_2\text{Sr}_2\text{Ca}_1\text{Cu}_2\text{O}_y$ (BSCCO), $\text{Bi}_2\text{Sr}_2\text{Ca}_2\text{Cu}_3\text{O}_y$,
3 $\text{Y}_1\text{Ba}_2\text{Cu}_3\text{O}_y$ (YBCO), $\text{Tl}_2\text{Ba}_2\text{Ca}_2\text{Cu}_3\text{O}_y$, $\text{Tl}_1\text{Ba}_2\text{Ca}_2\text{Cu}_3\text{O}_y$, $\text{Hg}_1\text{Ba}_2\text{Ca}_2\text{Cu}_3\text{O}_y$ and $\text{Hg}_1\text{Ba}_2\text{Ca}_1\text{Cu}_2\text{O}_y$.
4 In each of the above formulas, y represents the relative oxygen content in the range appropriate
5 for the particular superconducting ceramic oxide. Alternatively, precursors of superconducting
6 ceramic oxides can be used. Precursors are mixtures of oxides that collectively have the same
7 nominal composition as a superconducting ceramic oxide and which form a superconducting
8 ceramic oxide upon heating. The superconducting ceramic oxide or precursor used in the method
9 of the invention is initially in the form of a powder or slurry so that it can fill the open spaces
10 in the reticulated foam structure. The superconducting ceramic oxide or precursor is formed into
11 a powder or slurry by any conventional means.

12 The high temperature superconducting ceramic oxide composite of the present invention
13 is formed by filling the open spaces of the reticulated foam structure with a superconducting
14 ceramic oxide or precursor, compacting the filled structure and then heating the compacted
15 structure to melt and/or texture the ceramic oxide or precursor. These steps can be conducted in
16 any manner.

17 The temperature for the heating step depends on the melting and/or texturing temperature
18 of the particular ceramic oxide. When a superconducting ceramic oxide is used in the method of
19 the invention, the heating step serves to solidify and texture the superconducting ceramic oxide
20 to form a continuous region of the superconducting ceramic oxide throughout the structure and
21 to optimize the superconducting properties. Texturing is enhanced at the metal/superconductor

1 interface; therefore, the extensive interfaces provided by this invention will promote texturing.
2 Texturing occurs during the solidification process if the ceramic oxide material is melted. When
3 a precursor is used, the heating step also serves to effect the conversion of the precursor to the
4 superconducting ceramic oxide and then to solidify and texture the newly formed superconducting
5 ceramic oxide. Temperatures used in the melting and texturing of superconducting ceramic oxides
6 are typically in the range of 800° C to 1100° C.

7 The reticulated foam structure should be enclosed in a sheath before the step of filling the
8 continuous open cells of the reticulated foam structure with the high temperature superconducting
9 ceramic oxide or precursor to avoid the leakage and spillage of the material during the filling and
10 compacting steps. The sheath may be of any form and made of any material suitable for enclosing
11 the reticulated foam structure to prevent leakage and spillage and for being compacted.
12 Preferably, the sheath is a tubular material having the same chemical composition as the
13 reticulated foam structure.

14 The method of the present invention is particularly well-suited for forming
15 superconducting composite conductors, particularly wires, rods, or tapes. To form a
16 superconducting wire, rod or tape, the reticulated foam structure is placed inside a sheath, which
17 is preferably a hollow cylinder such as a tube or pipe of a suitable size to fit around the
18 reticulated foam structure. Preferably, the reticulated foam structure is in the shape of a cylinder
19 that has an outer diameter that is approximately equal to the inner diameter of the sheath so that
20 the reticulated foam structure fits snugly into the sheath. The sheath should be closed on one end
21 to prevent leakage of the superconducting ceramic oxide or precursor during the filling step and

Inventor's Name: Donald U. Gubser and M. Ashraf Imam

1 should have an open end through which the reticulated foam structure is filled with the
2 superconducting ceramic oxide or precursor. After the open cells of the reticulated foam structure
3 are filled, the sheath is closed or sealed. The sheath may then be formed into a rod or wire by
4 reducing the outer diameter of the sheath by any conventional means such as by drawing,
5 swaging or extruding. The sheath may be formed into a tape by any conventional means of
6 flattening. Forming the sheath into a wire, rod or tape also serves to compact the enclosed
7 reticulated foam structure and the superconducting ceramic oxide or precursor contained therein.
8 The wire, rod or tape is then heated to texture the superconducting ceramic oxide or, when
9 ceramic oxide precursors are used, to synthesize, melt and texture the corresponding
10 superconducting ceramic oxide so that a continuous region of high temperature superconducting
11 ceramic oxide is formed throughout the compacted reticulated foam structure. Shown
12 diagrammatically in Figure 1 is a cross section of a superconducting wire made according to the
13 process of the present invention, including the compacted reticulated foam structure 1, the high
14 temperature superconducting ceramic oxide 2, and the surrounding sheath 3.

15 In instances where it is desired to minimize thermal conduction along the composite, the
16 sheath may be removed by any conventional means. Shown diagrammatically in Figure 2 is a
17 cross section of a superconducting wire wherein the sheath has been removed, including the
18 compacted reticulated foam structure 4 and the high temperature superconducting ceramic oxide 5.

19 The preparation of a superconducting ceramic oxide composite may also include a step
20 of oxygenating the superconducting ceramic oxide to improve its superconducting properties.

21 The superconducting ceramic oxide composite or conductor of the present invention can

1 be used in any application where transporting electricity or generating a magnetic field with
2 minimal power loss is desired. The composite may be cooled below the temperature at which the
3 material becomes superconducting by any conventional means, including by immersing it in liquid
4 nitrogen, neon or helium, by convection cooling with a gas or by conductive cooling by attaching
5 the composite to a cryocooler.

6 Having described the invention, the following examples are given to illustrate specific
7 applications of the invention, including the best mode now known to perform the invention. The
8 specific examples are not intended to limit the scope of the invention described in this
9 application.

10 Examples

11 Example 1

12 Reticulated foam material of a silver-palladium alloy having about 90 % silver and a pore
13 size of 10 pores per inch was obtained from Energy Research and Generation, Inc., Oakland Ca.
14 The material was cut into the shape of a cylinder having a diameter of 1.5 cm and placed tightly
15 inside a copper tube that was sealed on one end. (Copper tubing was chosen only because of its
16 low cost and availability for quickly constructing an experimental prototype; the preferred
17 material for the practice of the invention is a silver-palladium alloy as described in Example 2
18 below.) The tube was then filled with YBCO powder so that the YBCO powder filled the open
19 cells of the reticulated foam material. The open end of the tube was capped shut and the tube was
20
21

Inventor's Name: Donald U. Gubser and M. Ashraf Imam

1 then swaged to form a wire. The copper sheath was then dissolved away by immersing the wire
2 in nitric acid. The wire was then melt-textured by slowly passing it through a furnace with a peak
3 temperature of 1050° C.

4 Fig. 3 shows a plot of voltage, V, vs. current, I, for a wire made as described above with
5 a cross-sectional area of 0.0616 cm². The measurements were made at 77°K with a zero magnetic
6 field. The plot shows a critical current, I_c of 21.5A., which gives a current density, J_c of 349
7 A/cm².

8 Example 2

9 Reticulated foam material of a silver-palladium alloy having about 90 % silver and a pore
10 size of 10 pores per inch is cut into the shape of a cylinder having a diameter of 1.5 cm and
11 placed tightly inside a tube of silver-palladium alloy of the same composition. The tube is sealed
12 on one end. The tube is then filled with YBCO powder. The open end of the tube is sealed. The
13 tube is then swaged to form a wire. The wire is then melt-textured by slowly passing it through
14 a furnace with a peak temperature of 1050° C.

15 Obviously, many modifications and variations of the present invention are possible in light
16 of the above teachings. It is therefore to be understood that,

17 the invention may be practiced otherwise than as specifically described.
18
19

Docket No.: N.C. 78,130

Inventor's Name: Donald U. Gubser and M. Ashraf Imam

PATENT APPLICATION

ABSTRACT

A high temperature superconducting composite rod, wire or tape is formed by filling the open cells of a reticulated foam structure made of silver, silver alloy, gold or gold alloy with a superconducting ceramic oxide or precursor, compacting the filled structure and forming it into a rod, wire or tape and heating it to melt and/or texture the superconducting ceramic oxide. The resulting composite has continuous ligaments of metal throughout a continuous region of superconducting ceramic oxide.

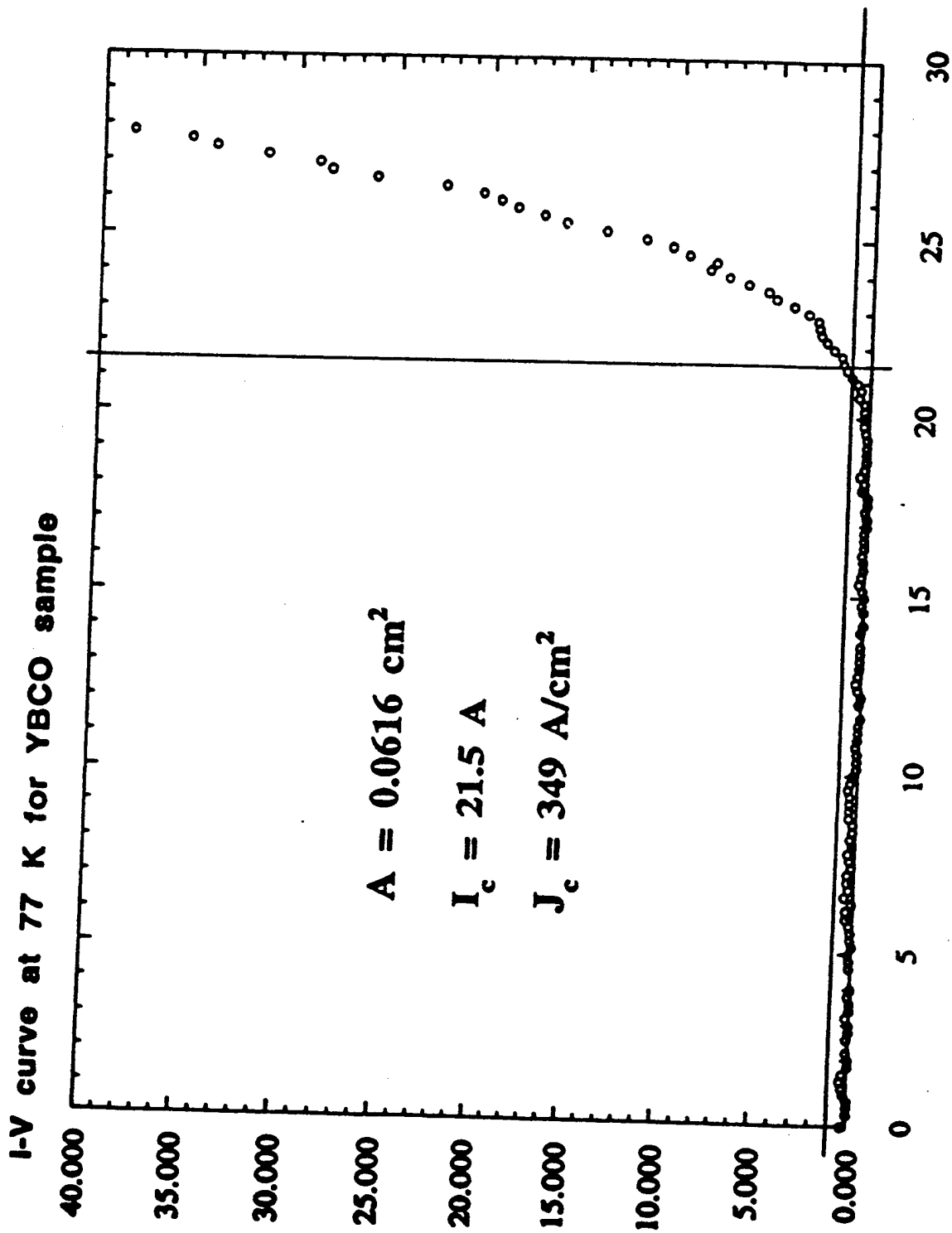

Fig. 3 S-I(A)

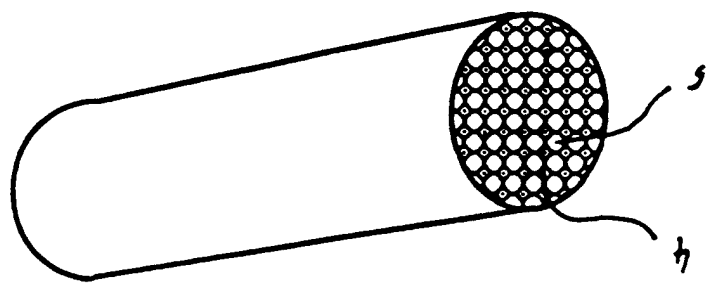

Fig. 2

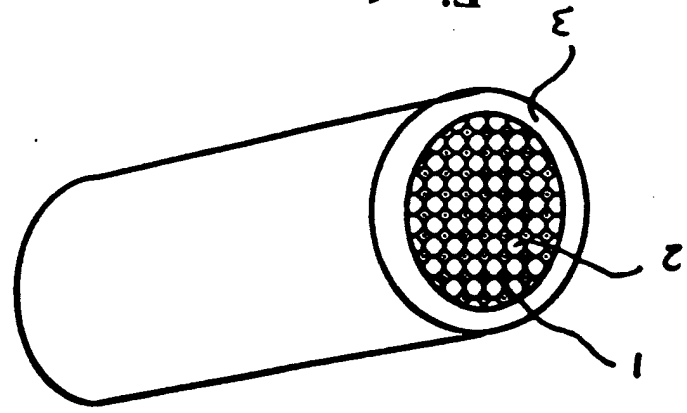

Fig. 1