

Serial No. 684,837
Filing Date 24 June 1996
Inventor Anthony W. Duva

NOTICE

The above identified patent application is available for licensing. Requests for information should be addressed to:

OFFICE OF NAVAL RESEARCH
DEPARTMENT OF THE NAVY
CODE OCCC3
ARLINGTON VA 22217-5660

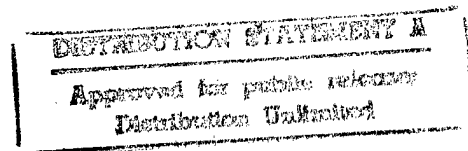

DTIC QUALITY INSPECTION

19970219 011

1 Navy Case No. 77690

2
3 FUEL OXIDIZER EMULSION INJECTION SYSTEM

4
5 STATEMENT OF GOVERNMENT INTEREST

6 The invention described herein may be manufactured and used
7 by or for the Government of the United States of America for
8 governmental purposes without the payment of any royalties
9 thereon or therefor.

10
11 CROSS-REFERENCE TO RELATED PATENT APPLICATION

12 This patent application is co-pending with related patent
13 application entitled Exhaust Control Through a Hydrogen Peroxide
14 Fuel Augmentation System (Navy Case No. 76760) by the same
15 inventor as this application.

16
17 BACKGROUND OF THE INVENTION

18 (1) Field of the Invention

19 The present invention relates to internal combustion engine
20 systems and more particularly to a system for reducing the
21 exhaust emissions of an internal combustion engine and for
22 allowing operation of an internal combustion engine in an oxygen
23 poor environment. The system utilizes a mixture of oxidant and
24 water which is emulsified with the fuel. The emulsion is
25 injected into the piston chamber of the engine. The oxidant

1 provides for near stoichiometric combustion to reduce combustion
2 products and reduce the engine's air requirements. The water
3 serves to cool the stoichiometric combustion temperature to
4 prevent excessive engine wear and to block the formation of
5 oxides of nitrogen.

6 (2) Description of the Prior Art

7 It is known to utilize fossil fuel distillates, such as
8 diesel fuel or gasoline, or organic fuels, such as alcohol, for
9 combustion in internal combustion engines. Typically, a piston
10 or rotary engine operates on a two or four cycle process to
11 compress air and inject fuel or a fuel/air mixture to initiate
12 combustion in a cylinder or chamber for the purpose of releasing
13 the thermal potential energy of the mixture to form a high
14 pressure, high temperature working fluid. In a piston engine,
15 the thermal energy is transferred to axial motion of the piston
16 which in turn rotates the main engine shaft to generate
17 mechanical work. In a rotary engine, the thermal energy is
18 transferred directly to the output shaft through rotation of the
19 rotor. For clarity, the remainder of the description will focus
20 on piston engines. However, it is to be understood that the
21 discussion applies to any power system in which thermal energy is
22 converted to mechanical energy.

23 The typical two or four cycle process uses available air as
24 a means to deliver the oxygenated working fluid necessary to burn
25 with the fossil or organic fuels. During the induction phase of

1 a diesel cycle, the piston displacement in a cylinder causes air
2 to be drawn into the cylinder. The air intake valve or port is
3 then closed as the piston begins traveling to the minimum volume
4 position of the cycle. As the air in the cylinder is compressed,
5 temperature and pressure of the air increase. Just prior to
6 reaching the minimum volume, maximum temperature and pressure
7 position, fuel is injected into the cylinder or pre-combustion
8 chamber. The fuel ignites in the presence of the high
9 temperature, high pressure air in a fuel rich central zone and
10 oxygen rich perimeter. In an internal spark ignition engine,
11 fuel is mixed with the air prior to compression. When
12 compressed, the fuel/air mixture is ignited with an electrical
13 stimulus from a spark plug. The combustion process initiates
14 from a point adjacent the spark and propagates outward to consume
15 the majority of the fuel/air mixture. In both engine types, the
16 combustion process is not steady and can be quenched by
17 relatively cold engine components.

18 These prior art engines generate several combustion
19 products, such as unburned hydrocarbons (HC), carbon monoxide
20 (CO) and oxides of nitrogen (NOx), which present environmental
21 hazards. Numerous studies, e.g., Jiang, Q., Ottikkutti, P.,
22 VanGerpen, J., VanMeter, D.,: "The Effect of Alcohol Fumigation
23 on Diesel Flame Temperature and Emissions," Society of Automotive
24 Engineers Transactions Volume 99, Section 3, 1990 paper number
25 900386, have shown a direct correlation of NOx formation to

1 combustion temperature. However, lowering the combustion
2 temperature also results in incomplete combustion with a
3 corresponding increase in HC and CO emissions. Also, these
4 engines are dependent on receiving adequate oxygen for combustion
5 from the ambient air, making them unsuitable for operation in
6 oxygen poor environments, such as in ultra high altitude
7 environments or in underwater environments. To provide the
8 necessary oxygen to systems operating in these environments,
9 extraordinary measures must be taken, such as carrying liquid
10 oxygen or providing multiple stages of turbo charging. The
11 resulting systems are heavy, inefficient and quite large in size.
12 Further, controllers within these engines attempt to improve
13 efficiency and reduce emissions by controlling the flow of
14 ambient air into the engine and thus the fuel/air mixture being
15 combusted in the cylinder compartment. Such control systems do
16 provide improved efficiency and reduced emissions, but may not
17 result in the most efficient combustion or lowest emissions. The
18 oxygen content of the ambient air may vary significantly such
19 that it may be impossible for the controller to provide adequate
20 oxygen, regardless of air flow. In the case of underwater
21 operation, no air is available to provide the necessary oxygen.

22 23 SUMMARY OF THE INVENTION

24 Accordingly, it is a general purpose and object of the
25 present invention to provide a system for an internal combustion

1 engine to control and reduce environmentally hazardous exhaust
2 emissions such as hydrocarbons, carbon monoxide and oxides of
3 nitrogen.

4 It is a further object that the system provide a means for
5 operating internal combustion engines in standard, low and oxygen
6 depleted environments.

7 These objects are accomplished with the present invention by
8 providing an injection system for an internal combustion engine
9 which utilizes an oxidant and water mixture emulsified within the
10 fuel. The emulsion is injected into the piston chamber in a
11 manner similar to current fuel injection methods. The emulsion
12 serves to lower the combustion temperature which in turn lowers
13 the formation of oxides of nitrogen. The oxidant within the fuel
14 provides sufficient oxygen for complete combustion of the fuel
15 which reduces environmentally harmful combustion products such as
16 unburned hydrocarbons and carbon monoxide. Complete combustion
17 may lead to excessive engine temperatures and wear. The water
18 added to the oxidant quenches the stoichiometric combustion
19 temperature, preventing excessive engine wear and also
20 contributing to the reduction of oxides of nitrogen. The oxidant
21 further provides the necessary oxygen for combustion and reduces
22 the need to obtain oxygen from the ambient air, thus allowing
23 operation of the engine in oxygen poor environments.

1 BRIEF DESCRIPTION OF THE DRAWINGS

2 A more complete understanding of the invention and many of
3 the attendant advantages thereto will be readily appreciated as
4 the same becomes better understood by reference to the following
5 detailed description when considered in conjunction with the
6 accompanying drawings wherein corresponding reference characters
7 indicate corresponding parts throughout the several views of the
8 drawings and wherein:

9 FIG. 1 shows a cross sectional view of an engine with the
10 emulsion injection system of the present invention; and

11 FIG. 2 shows a schematic representation of the injection
12 system of the present invention.

13
14 DESCRIPTION OF THE PREFERRED EMBODIMENT

15 Referring now to FIG. 1, there is shown a cross sectional
16 view of an engine 10 taken through piston chamber 12 of engine
17 10. As piston 14 moves away from top surface 16 of chamber 12,
18 air intake valve 18 opens to allow air into piston chamber 12, as
19 shown by arrows 20. As piston 14 moves back toward surface 16,
20 valve 18 closes stopping the flow of air. Just prior to maximum
21 compression, injector 22 injects fuel oxidant emulsion, indicated
22 by lines 24, into chamber 12. The fuel oxidant emulsion ignites
23 in the presence of the high temperature, high pressure air. The
24 ignition forces piston 14 away from surface 16, and this power
25 stroke movement is converted to useful work. In a typical four

1 stroke engine, piston 14 again moves towards surface 16 and
2 expels combustion gases through an exhaust port (not shown in
3 FIG. 1). The four stroke cycle of air intake, compression,
4 power stroke and exhaust begins again.

5 Referring now additionally to FIG. 2, there is shown a
6 schematic representation of a fuel oxidizer emulsion system 26
7 for use on engine 10. Standard fossil or organic fuel is stored
8 in fuel tank 28 and an oxidant is stored in oxidant tank 30. The
9 oxidant used may be hydrogen peroxide, hydroxyl ammonium nitrate,
10 or any such liquid oxidant whose chemical decomposition readily
11 liberates free oxygen upon heating or increased pressure. Tanks
12 28 and 30 are connected to mixing control valve 32 where the fuel
13 and oxidant fed to and combined in fuel pump 34 to form emulsion
14 24. Emulsion 24 is fed through injector 22 into piston chamber
15 12. Exhaust outlet 36 is connected to chamber 12 via exhaust
16 port 38. Sensor 40 in exhaust outlet 36 provides temperature and
17 oxygen level readings to controller 42 which operates mixing
18 control valve 32 to control the amount of oxidant used to form
19 emulsion 24 entering chamber 12. Sensor 40 monitors the
20 temperature and oxygen level of the combustion byproducts and may
21 also monitor ambient air oxygen levels. Depending on the
22 internal parameters chosen, controller 42 may also vary the
23 amount of ambient air introduced into chamber 12 by controlling
24 air intake valve 18 opening and may also control the flow of fuel
25 oxidant emulsion 24 through injector 22. In oxygen poor

1 environments, such as high altitude operation, controller 42 may
2 allow additional oxidant to enter through control valve 32 to
3 satisfy oxygen requirements for combustion, or the air to fuel
4 ratio may be increased by controller 42 allowing additional
5 ambient air through intake valve 18, or a combination of both
6 additional oxidant and air may be required depending on the
7 parameters set and the readings obtained from sensor 40. In
8 oxygen depleted environments, such as underwater, air intake
9 valve 18 would remain closed and the total oxygen requirements
10 would be provided by the fuel oxidant emulsion.

11 The fuel oxidant emulsion injection system of the present
12 invention has many advantages over the prior art. Controller 42
13 acts in a manner similar to fuel/air mixture controllers in
14 existing engine systems. However, more precise control of the
15 oxygen level can be obtained by having the controller govern the
16 amount of oxidant combining with the fuel since, unlike ambient
17 air, the fuel oxidant emulsion is a determinable oxygen source.
18 The greater control afforded by the use of the present system
19 provides for more efficient combustion and reduced emissions.
20 Further, depending on the emulsion used, the engine is provided
21 with an essentially unlimited source of oxygen allowing operation
22 in oxygen poor and oxygen depleted environments.

23 What has thus been described is a system for injecting a
24 fuel oxidant emulsion into the combustion chamber of an internal
25 combustion engine to improve efficiency and reduce harmful

1 emissions. The emulsion also provides the necessary oxygen to
2 run the engine in oxygen poor or oxygen depleted environments,
3 such as high altitude operation or underwater operation. The
4 system has a fuel tank and an oxidant tank. A controlled amount
5 of oxidant is added to the fuel by a mixing valve just prior to
6 the fuel pump. The fuel and oxidant mix or emulsion are pumped
7 to the combustion chamber of the engine. The flow of emulsion
8 into the chamber is governed by an injector and the air intake
9 into the chamber is governed by an air intake valve. A
10 controller governs the fuel/oxidant mixing valve, the injector
11 and the air intake into the chamber. The controller senses the
12 temperature and level of oxygen in the engine exhaust as well as
13 the ambient fluid oxygen level and controls the air intake flow,
14 the fuel/oxidant mixture and the emulsion flow to maintain
15 maximum efficiency and minimum emissions in accordance with
16 predetermined parameter settings.

17 Obviously many modifications and variations of the present
18 invention may become apparent in light of the above teachings.
19 For example, the system can be used on any type of engine burning
20 fossil or organic fuels. Also, the oxidant can be any one of a
21 number of substances which provide free oxygen for combustion,
22 such as hydrogen peroxide or hydroxyl ammonium nitrate.

23 In light of the above, it is therefore understood that
24 the invention may be
25 practiced otherwise than as specifically described.

2 FUEL OXIDIZER EMULSION INJECTION SYSTEM

3
4 ABSTRACT OF THE DISCLOSURE

5 A system for improving efficiency and reducing harmful
6 emissions in an internal combustion engine and for allowing the
7 engine to run in oxygen poor and oxygen depleted environments.
8 An oxidant, such as hydrogen peroxide, is emulsified with engine
9 fuel. The emulsion is injected into the combustion chamber of
10 the engine. A controller senses the temperature and oxygen level
11 in the exhaust stream of the engine as well as the oxygen level
12 in the ambient fluid. The controller operates a valve to vary
13 the amount of oxidant added to the fuel as well as controlling
14 the amount of ambient air introduced into the chamber and the
15 injection of the fuel oxidant emulsion into the chamber. The
16 controller parameters are set to maintain maximum efficiency and
17 minimum emissions. The oxidant in the emulsion provides for near
18 stoichiometric combustion to reduce combustion products and
19 reduce the engine's air requirements. The reduced air
20 requirements allow for operation of the engine in oxygen poor
21 environments and in oxygen depleted environments, such as
22 operation at high altitudes or operation underwater. Water is
23 added to the emulsion oxidant to cool the stoichiometric
24 combustion temperature to prevent excessive engine wear and to
25 further block the formation of oxides of nitrogen.

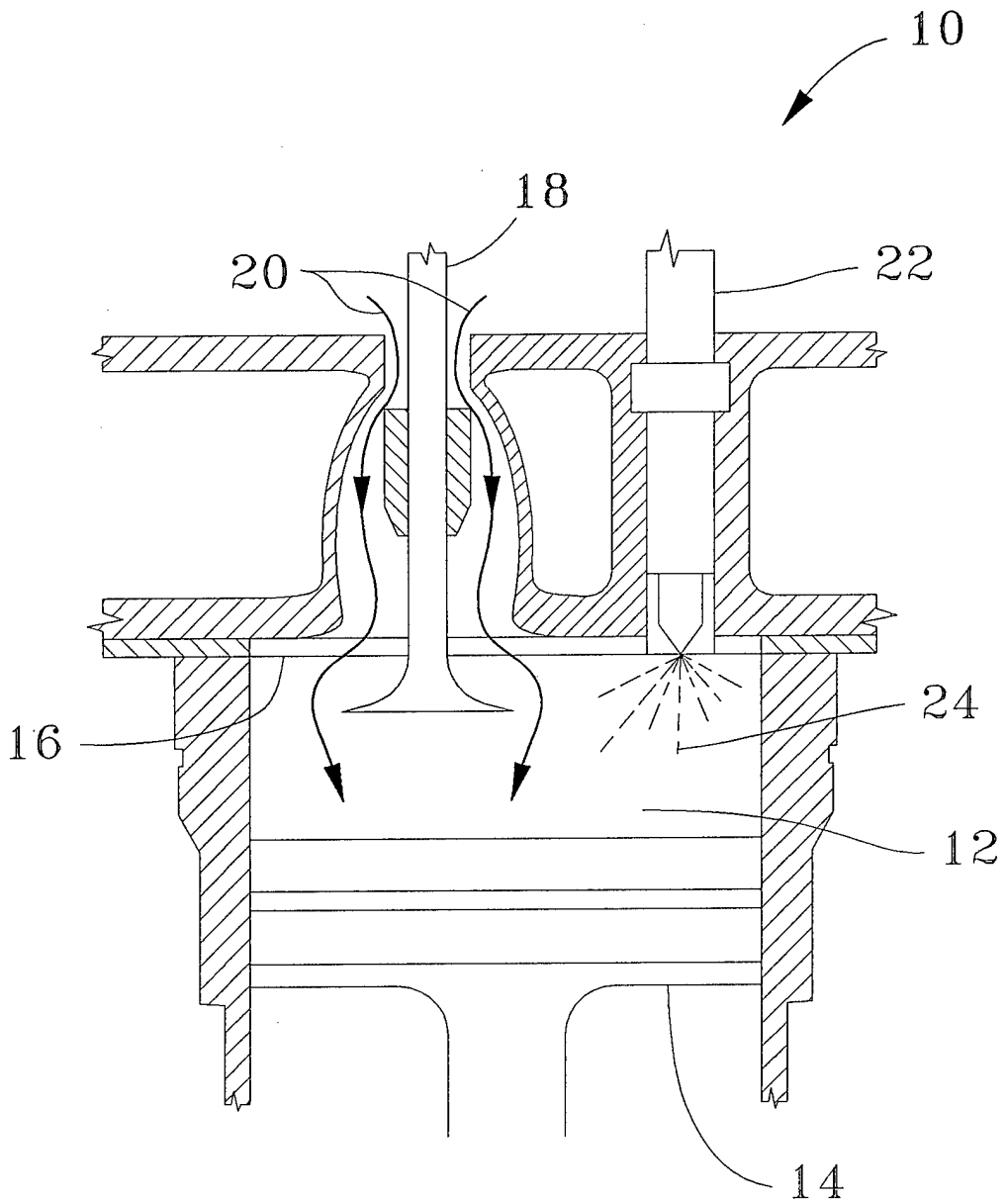

FIG. 1

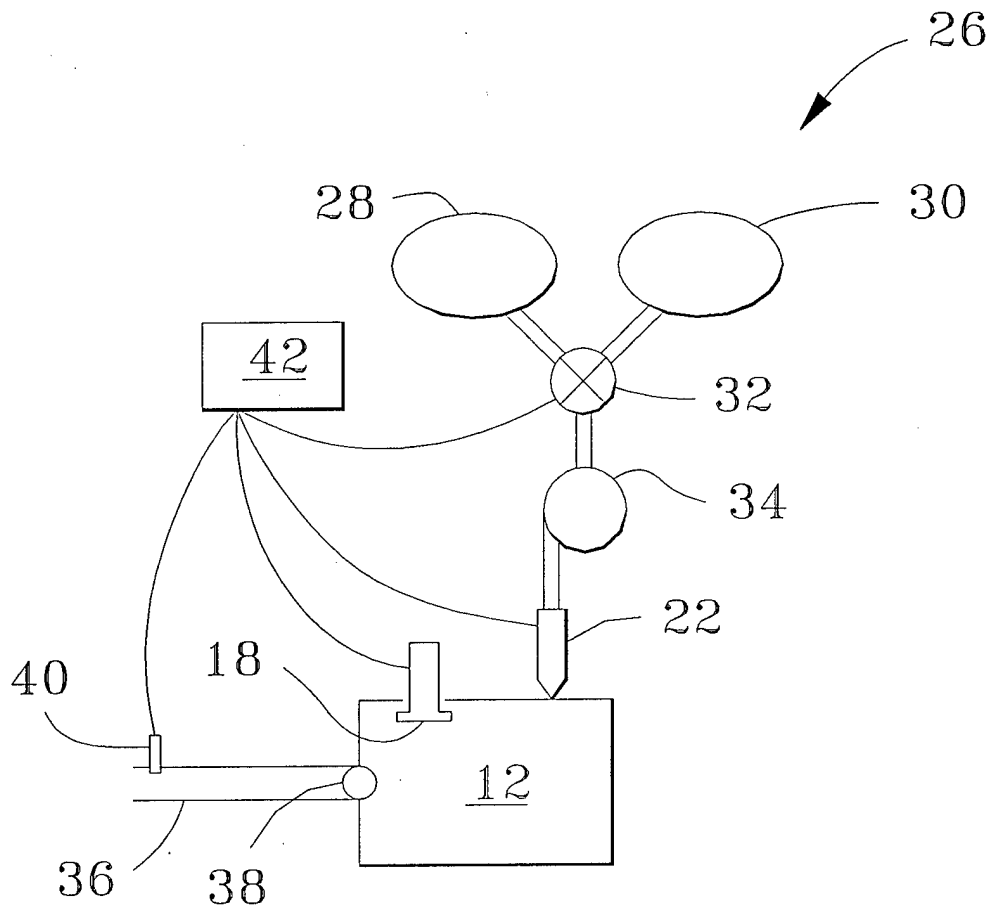

FIG. 2