

UNCLASSIFIED

AD NUMBER

ADB951672

LIMITATION CHANGES

TO:

Approved for public release; distribution is unlimited.

FROM:

Distribution authorized to U.S. Gov't. agencies only; Administrative/Operational Use; JAN 1954. Other requests shall be referred to Defense Nuclear Energy, Washington, DC.

AUTHORITY

DNA ltr 25 Apr 1980

THIS PAGE IS UNCLASSIFIED

**UNCLASSIFIED**

**WT-779**

This document consists of 142 pages  
No. 121 of 180 copies, Series A

**OPERATION UPSHOT-KNOTHOLE**

Project 9.1

**TECHNICAL PHOTOGRAPHY**

*REPORT TO THE TEST DIRECTOR*

by

**William R. Greer, Jr., Maj., USA**  
**Ernest F. Dukes, Jr., Capt., USAF**

January 1954



Armed Forces Special Weapons Project  
Washington, D. C.



**UNCLASSIFIED**

SHO 00640 / 121

**Reproduced Direct from Manuscript Copy by  
AEC Technical Information Service  
Oak Ridge, Tennessee**

**Inquiries relative to this report may be made to  
Chief, Armed Forces Special Weapons Project  
P. O. Box 2610  
Washington, D. C.**

**If this report is no longer needed, return to  
AEC Technical Information Service  
P. O. Box 401  
Oak Ridge, Tennessee**

### ABSTRACT

Project 9.1 provided a centralized organization responsible for all technical motion picture and still photography required by the various military effects projects in Operation UPSHOT-KNOTHOLE.

Technical motion picture photography was employed to record on film the effects of blast and thermal radiation from Shots 9 and 10 on various test objects. In addition, the shock front itself was photographed on Shots 1, 4, 9, 10, and 11.

All zero time technical photography was done from individual photo stations, generally steel towers, which were located at distances between 1150 and 15,000 feet from intended ground zero. Shot 9 was covered by 193 cameras of various types ranging in speed from two frames per minute to 2500 frames per second. To support these cameras, 100 towers between 6 and 25 feet high were used. Shot 10, although covered on a smaller scale, utilized 94 cameras on 50 towers. Shots 1, 4 and 11 were covered by four cameras mounted in photo trailers.

Results of the photography were quite successful. The photographic hazards accompanying a nuclear detonation; namely dust, thermal and nuclear radiation, blast, and rapidly changing illumination were all satisfactorily overcome at distances from ground zero greater than about 2500 feet. At closer distances results were quite unsatisfactory as had been predicted. In general, it is possible to conclude that photographic instrumentation is feasible within certain limitations.

It is recommended that in any future tests of this nature a "camera line" be established and stabilization provided in one continuous strip. In planning for a future test it would be advisable to consider using the methods and equipment developed for this test.

## FOREWORD

This report is one of the reports presenting the results of the 78 projects participating in the Military Effects Tests Program of Operation UPHOT-KNOTHOLE, which included 11 test detonations. For readers interested in other pertinent test information, reference is made to WT-782, Summary Report of the Technical Director, Military Effects Program. This summary report includes the following information of possible general interest.

- a. An over-all description of each detonation, including yield, height of burst, ground zero location, time of detonation, ambient atmospheric conditions at detonation, etc., for the 11 shots.
- b. Compilation and correlation of all project results on the basic measurements of blast and shock, thermal radiation, and nuclear radiation.
- c. Compilation and correlation of the various project results on weapons effects.
- d. A summary of each project, including objectives and results.
- e. A complete listing of all reports covering the Military Effects Tests Program.

PRECEDING PAGE BLANK - NOT FILMED

**UNCLASSIFIED**

#### ACKNOWLEDGMENTS

The satisfactory completion of the technical photographic program for Operation UPSHOT-KNOTHOLE was made possible only by the wholehearted cooperation and support of a number of agencies, both military and civilian, and individuals. It is the desire of the authors to acknowledge the efforts of all contributing to the success of this project.

The authors specifically wish to acknowledge the direct support of Edgerton, Germeshausen and Grier, Inc. who contracted to perform the technical photography on top of an already heavy photographic commitment to the Atomic Energy Commission. In particular the services of Mr. Frederick E. Barstow and Mr. Benjamin Brettler are gratefully acknowledged.

In addition, acknowledgment is extended the U. S. Army Signal Corps and the U. S. Air Force who furnished skilled photo personnel to augment EG&G's own small force. The officers and enlisted men from these two services performed their duties in a commendable manner and thanks are extended for a job well done. The untiring efforts and services of YN2 Charles L. Miller, U. S. Navy, who typed the manuscript are appreciated.

Finally, the authors wish to render their sincere thanks to Mr. Herbert E. Grier of Edgerton, Germeshausen and Grier, Inc. for his appreciation of the magnitude of the photographic plan for this project and his continued guidance, encouragement and patience.

**UNCLASSIFIED**

CONTENTS

ABSTRACT . . . . . 3

FOREWORD . . . . . 5

ACKNOWLEDGMENTS . . . . . 6

ILLUSTRATIONS . . . . . 10

TABLES . . . . . 10

CHAPTER 1 INTRODUCTION . . . . . 11

    1.1 General . . . . . 11

    1.2 Objective . . . . . 11

    1.3 Background . . . . . 11

    1.4 Organization . . . . . 12

CHAPTER 2 TECHNICAL PREPARATION . . . . . 13

    2.1 General . . . . . 13

    2.2 Project Objectives . . . . . 13

        2.2.1 Effects Photography . . . . . 13

        2.2.2 Blast and Shock Photography . . . . . 13

    2.3 Basic Technical Considerations . . . . . 13

        2.3.1 Dust . . . . . 14

        2.3.2 Thermal Radiation . . . . . 15

        2.3.3 Nuclear Radiation . . . . . 16

        2.3.4 Blast . . . . . 19

        2.3.5 Illumination . . . . . 19

    2.4 Choice of Cameras . . . . . 19

    2.5 Choice of Films . . . . . 20

**UNCLASSIFIED**

CHAPTER 3	INSTRUMENTATION . . . . .	21
3.1	General . . . . .	21
3.2	Mechanical . . . . .	21
3.3	Electrical . . . . .	23
3.4	Photographic . . . . .	23
3.4.1	GSAP Cameras . . . . .	23
3.4.2	High Speed Mitchell Cameras . . . . .	24
3.4.3	High Speed Eastman Cameras . . . . .	25
3.4.4	Fastax Cameras . . . . .	25
3.4.5	A-5 Cameras . . . . .	25
3.4.6	Robot Cameras . . . . .	25
3.4.7	Summary . . . . .	26
CHAPTER 4	OPERATIONS . . . . .	27
4.1	General . . . . .	27
4.2	Preparations . . . . .	27
4.3	Installation of Equipment . . . . .	27
4.4	Pre-Shot Operations . . . . .	28
4.5	Reference Markers . . . . .	30
4.6	Film Recovery . . . . .	31
4.7	Processing and Printing . . . . .	31
CHAPTER 5	RESULTS . . . . .	32
5.1	General . . . . .	32
5.2	Camera Operation . . . . .	32
5.3	Photographic Hazards . . . . .	32
5.3.1	Dust . . . . .	32
5.3.2	Thermal Radiation . . . . .	34
5.3.3	Nuclear Radiation . . . . .	34
5.3.4	Blast . . . . .	34
5.3.5	Illumination . . . . .	35
5.4	Picture Quality . . . . .	35
CHAPTER 6	CONCLUSIONS AND RECOMMENDATIONS . . . . .	36
6.1	Conclusions . . . . .	36
6.2	Recommendations . . . . .	36





APPENDIX A	FILM DATA SHEETS . . . . .	37
A.1	General . . . . .	37
A.2	Cameras . . . . .	37
A.2.1	Types Used . . . . .	37
A.2.2	Vertical Angle . . . . .	37
A.2.3	Frames/Second . . . . .	37
A.3	Timing Markers . . . . .	38
A.3.1	100 and 200 Cycles/sec Markers . . . . .	38
A.3.2	2 and 12 Cycles/sec Markers . . . . .	38
A.4	Film . . . . .	39
A.4.1	Type Used . . . . .	39
A.4.2	Numbers . . . . .	39
A.5	Filters . . . . .	39
A.6	Towers . . . . .	39
A.7	Prints . . . . .	39
A.7.1	Distribution . . . . .	39
A.7.2	Identification . . . . .	40
A.8	Photographic Station Designation . . . . .	40
APPENDIX B	SHOT 9 CAMERA STATIONS . . . . .	42
B.1	General . . . . .	42
B.2	Form . . . . .	42
APPENDIX C	SHOT 10 CAMERA STATIONS . . . . .	99
C.1	General . . . . .	99
C.2	Form . . . . .	99
APPENDIX D	STILL PHOTOGRAPHY . . . . .	135
D.1	General . . . . .	135
D.2	Objective . . . . .	135
D.3	Organization . . . . .	135
D.4	Determination of Requirements . . . . .	135
D.5	Summary of Still Photographic Coverage . . . . .	136
D.6	Recommendations . . . . .	136

**UNCLASSIFIED**

ILLUSTRATIONS

2.1 A 17 Ft Camera Tower Installed on a Stabilized Area . . . . . 15  
2.2 Typical Camera Station with Stabilization . . . . . 17  
2.3 Typical Shielding Curves for Several Films . . . . . 18  
3.1 Sketch of an Unguyed 6 Ft Tower . . . . . 22  
3.2 GSAP Camera and Associated Mounting Hardware . . . . . 24  
4.1 Camera Station Covered with Plastic Bag . . . . . 29  
4.2 Unshielded Camera Installation . . . . . 30

TABLES

3.1 Summary of Camera Characteristics . . . . . 26  
4.1 Summary of Cameras Employed . . . . . 28  
5.1 Breakdown of Equipment Failures - Shot 9 . . . . . 33  
5.2 Breakdown of Equipment Failures - Shot 10 . . . . . 33  
A.1 Designation of Photographic Station . . . . . 41  
B.1 Shot 9 Camera Data . . . . . 43  
C.1 Shot 10 Camera Data . . . . . 100

~~UNCLASSIFIED~~

# CONFIDENTIAL

## CHAPTER 1

### INTRODUCTION

#### 1.1 GENERAL

The purpose of this report is to present in detail the technical photographic phase of Project 9.1 for Operation UPSHOT-KNOTHOLE. The still photography phase, showing construction progress and targets before and after the blasts, is included in this report as Appendix D. Documentary photography for historical and record purposes this operation was performed by the Lookout Mountain Laboratory and is not included in this report.

#### 1.2 OBJECTIVE

The object of Project 9.1 was to provide centralized zero time (films exposed 1/2 hr before or after zero time) technical photography as requested by the various military effects projects participating in UPSHOT-KNOTHOLE under the direction of Programs 1 through 9. This was accomplished by employing a large number of photo stations which in turn exposed films shortly before zero time and for various lengths of time thereafter. Each photo station was an independent entity. These stations were located at a distance between 1150 ft and 15,000 ft from intended ground zero. It was also the objective of Project 9.1 to perform technical still photography required to record the construction sequence and to give pre-test and post-test records to show clearly the test results.

#### 1.3 BACKGROUND

Motion picture photography is in some respects the most satisfactory means of scientific instrumentation for typical projects on a weapons effects test. The many advantages of photography are obvious and need no elaboration. It can and does provide both quantitative and qualitative information in volume from one small strip of film. This was realized before the very earliest tests and as a result, all nuclear detonations have had heavy photographic coverage.

However, photographic coverage at zero time of the effects of nuclear detonations requires exposing the cameras to these detonations and some of the resulting effects make photography exceedingly difficult. Consequently, results have been spotty on past tests.

~~CONFIDENTIAL~~  
**UNCLASSIFIED**

Enough information has been obtained on Operations GREENHOUSE, BUSTER-JANGLE and TUMBLER-SNAPPER to arouse a great deal of enthusiasm for this type of instrumentation.

When UPSHOT-KNOTHOLE was conceived, it was determined to put the photographic instrumentation on a systematic basis. Rather than have each project perform its own photography, the entire photographic effort was given program status and technical action picture and still photography was assigned to Project 9.1.

The agencies selected to perform this job were Edgerton, Germeshausen and Grier, Inc. of Boston, and the U. S. Army Signal Corps. Edgerton, Germeshausen and Grier, Inc. did this type of photography on all previous nuclear tests.

#### 1.4 ORGANIZATION

Project 9.1 consisted of the Project Officer, Captain Ernest F. Dukes, Jr., USAF; the contractor, EG&G; and officers and enlisted men from the U. S. Army Signal Corps and the USAF. In addition, the Program Director, Major William R. Greer, Jr., devoted the principal part of his time to this project.

The Program Director and the Project Officer determined the photographic requirements of the various project agencies. They then worked with the contractor in formulating the exact details of the AFSWP photographic plan and its implementation.<sup>1/</sup>

The personnel from the Signal Corps and USAF were assigned to and worked directly with the civilian contractor under the same conditions as his own employees. This arrangement was in accordance with past practices and worked satisfactorily in all respects.

<sup>1/</sup>"Preliminary Report, EG&G Photography for Weapons Effects Program, Operation KNOTHOLE," Report No. 1084, dated 27 February 1953, classified SECRET Security Information RESTRICTED DATA.

~~CONFIDENTIAL~~  
**UNCLASSIFIED**

## CHAPTER 2

### TECHNICAL PREPARATION

#### 2.1 GENERAL

The difficulty and expense of zero time motion picture photography increases as the camera station approaches ground zero. As a result, it was decided not to attempt photography within 2000 ft of ground zero on Shots 9 and 10, as the results would hardly justify the effort. This decision was relaxed in several cases, with very poor results, as the importance of some projects justified a decision to attempt the close-in photography. Camera stations closer than 1700 ft to ground zero were operated without the benefit of stabilization, except for the experimental stabilization plots of Project 9.7.

In planning, an effort was made to locate camera stations so that the cameras could be leveled while still covering the full field of view required. This was done to simplify the photogrammetric problem since tilting a camera introduces distortion of the image in the film plane and greatly complicates the making of accurate measurements. The cameras were mounted in a tilt position in many cases, overriding photogrammetric considerations, to bring the camera closer to the subject.

#### 2.2 PROJECT OBJECTIVES

A breakdown of the photographic requirements obtained from the project officers revealed that the project effort could be divided into two basic categories.

##### 2.2.1 Effects Photography

Normal (24 frames/sec), medium (24-100 frames/sec), or high speed (500-2500 frames/sec) motion pictures of the effects of blast and/or thermal radiation upon test objects placed within a distance of 15,000 ft from the point of detonation of the weapon.

##### 2.2.2 Blast and Shock Photography

Medium and high speed motion pictures of the shock front itself.

A further breakdown within these categories would divide all projects into those desiring qualitative information and those who wished to make measurements from their films, either linear or time.

#### 2.3 BASIC TECHNICAL CONSIDERATIONS

Obstacles to good zero time photography are: the tremendous quantities of dust raised by the shock front and accompanying blast wind; the effects of blast on the camera; the photo-chemical effect of

nuclear radiation on film; smoke caused by the intense thermal radiation on combustibles (including "popcorning" of the ground); and the rapidly changing illumination from the fireball.

From its inception, the whole program was guided so as to diminish the effects of these hazards upon the final films. This was accomplished insofar as practicable as discussed in the following sections.

### 2.3.1 Dust

The greatest difficulty encountered in photographing the results of an atomic detonation over land is dust. Dense clouds of it raised by the blast wind can blanket out the entire field of view of the camera in an extremely short period of time. A quantitative estimate of this hazard was difficult to obtain. Films of BUSTER-JANGLE and TUMBLER-SNAPPER, taken along the blast line were analyzed, and estimates of the dust hazard made from these. It was observed that the dust cloud followed the shock wave almost simultaneously (when observed at about 30 frames/sec), but that for distances beyond about 2000 ft, it took several seconds for the dust to rise far enough above the ground to completely obscure the field of view of the cameras mounted on towers 25 ft high. Realizing that there was some correspondence between TUMBLER 4 and Shot 9 (8 May 1953) and Shot 10 (25 May 1953), in yield, height of burst, and type of ground surface, it was decided to base estimates of dust on these data and act accordingly.

The decision was made to place cameras on towers high enough to get above the dust. The heights of the camera towers were standardized at 18, 11, and 6 ft in all but a few special cases. The 18 ft towers were generally used within a radius of 4000 ft from ground zero where dust was determined to be the thickest. In many cases they were used beyond this point for various reasons. Also some shorter towers were used within this radius where special considerations overrode the desirability of getting well above the dust. A typical camera station is shown in Fig 2.1. A second step was taken to defeat the dust by using a wide angle lens and placing the tower as close to the object being photographed as was possible.

By far the most elaborate precaution taken to preclude dust was a vast soil stabilization program.<sup>2/</sup> In general, the stabilization consisted of covering the area around the camera station-object station with a low grade sand cement mix approximately 2 in. thick. The area to be stabilized was computed from particle displacement versus distances from ground zero curves obtained from information submitted by the Sandia Corporation. The maximum particle displacement at a camera station was determined, and this distance plus 15 per cent

<sup>2/</sup> Operation UNSHOT-KNOTHOLE, Project 9.6, Production Stabilization, WT-780 classified CONFIDENTIAL RESTRICTED DATA.

**UNCLASSIFIED**

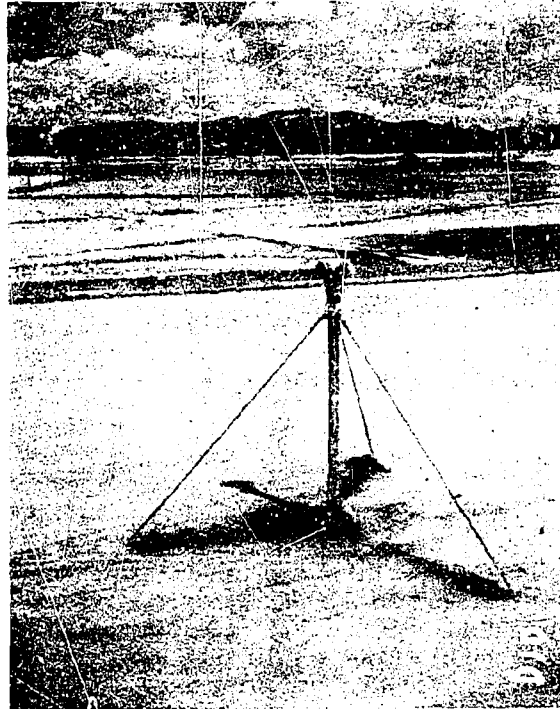

Fig. 2.1 A 17 Ft Camera Tower Installed on a Stabilized Area

laid out on the ground zero side of the camera tower or camera target, whichever was closer to ground zero. This was repeated on the other side of the object being photographed, using particle displacement during the negative phase of the shock wave. The negative phase distance of particle transport was assumed to be 75 per cent of the positive phase displacement. This area and 50 ft on either side of the camera station-object station area was stabilized. Figure 2.2 shows a typical stabilized camera station area. To keep the collection of dust upon the stabilized areas at a minimum, they were vacuum-cleaned intermittently by several power cleaners. In addition, vehicular traffic was held to a minimum over the stabilized areas.

Thus, three methods were used to assist in the control of the dust problem; elevating the cameras, and where possible, the objects being photographed; bringing the targets closer to the camera; and stabilizing the camera station-object station area.

#### 2.3.2 Thermal Radiation

Second only to dust as a photographic problem are the effects of

thermal radiation. Like dust, the smokes caused by the action of the thermal radiation on various combustibles can rapidly obscure the entire field of view of the camera. This is particularly true when the smoke is near the camera lens. Consequently, great pains were taken to avoid having any combustible material used in construction of the camera towers. The camera housings were left unpainted, for example, and all cables were run inside the tower or in conduit, and the guy wires of the camera towers were wrapped with aluminum foil. In addition, the upper third of the towers facing toward ground zero were sand blasted. The various projects were warned, where applicable, either to paint their equipment with a heat reflectant paint or to remove the paint.

The soil stabilization was chosen primarily because of its protection against the dust due to the shock winds and secondly for its resistance to the raising of dust and smoke clouds due to thermal radiation.

### 2.3.3 Nuclear Radiation

Since most of the photography was to be done within a mile of ground zero, the effects of nuclear radiation on film had to be avoided. Gamma radiation produces the same photo-chemical effect on film as visible radiation. It was necessary, therefore, to take precautions to guard against this nuclear film fogging. This was accomplished in two ways; by choosing a film that was relatively insensitive to gamma radiation, and by furnishing lead shielding where necessary.

Fortunately, EG&G had developed in conjunction with the Eastman Kodak Co., a special emulsion called "Type 918" or special order microfilm (MF) for use in fireball photography. In addition to the properties which made it useful for that purpose, it was found that it could be exposed to a very large dose of gamma radiation without producing an appreciable background density. To produce background density of 0.6, on a weapon such as was used for Shot 9, for example, would require an exposure of about 600 roentgens (r) for Type 918, 25 r for Background X (BK) and only 1 r for Super XX (SIX). This reduced the shielding requirements tremendously. As a result, this emulsion was used at all locations where nuclear radiation was a problem, except for those few projects which required other emulsions.

Despite the relative insensitivity of this emulsion to nuclear radiation, the magnitude of the expected radiation was such that shielding would still be necessary at many stations. At a distance of about 2000 ft from ground zero, 2½ in. of lead would give satisfactory shielding for Type 918 emulsion for both Shots 9 and 10, so this thickness of lead was standardized for all camera shields. In some cases, a greater thickness would have allowed the use of a more desirable emulsion, but this was not done both in the interest of standardization and because it would have required heavier and more expensive camera towers. Figure 2.3 illustrates typical shielding

~~CONFIDENTIAL~~  
**UNCLASSIFIED**



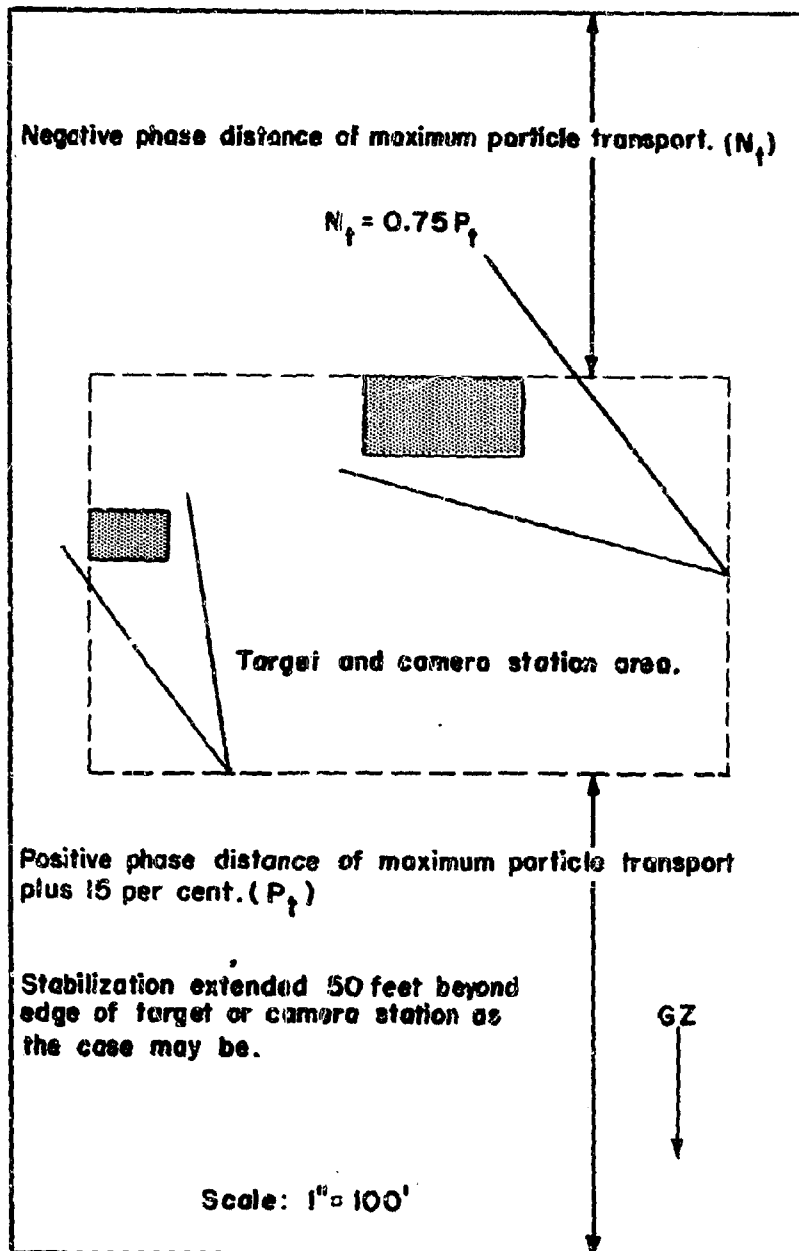

Fig. 2.2 Typical Camera Station with Stabilization

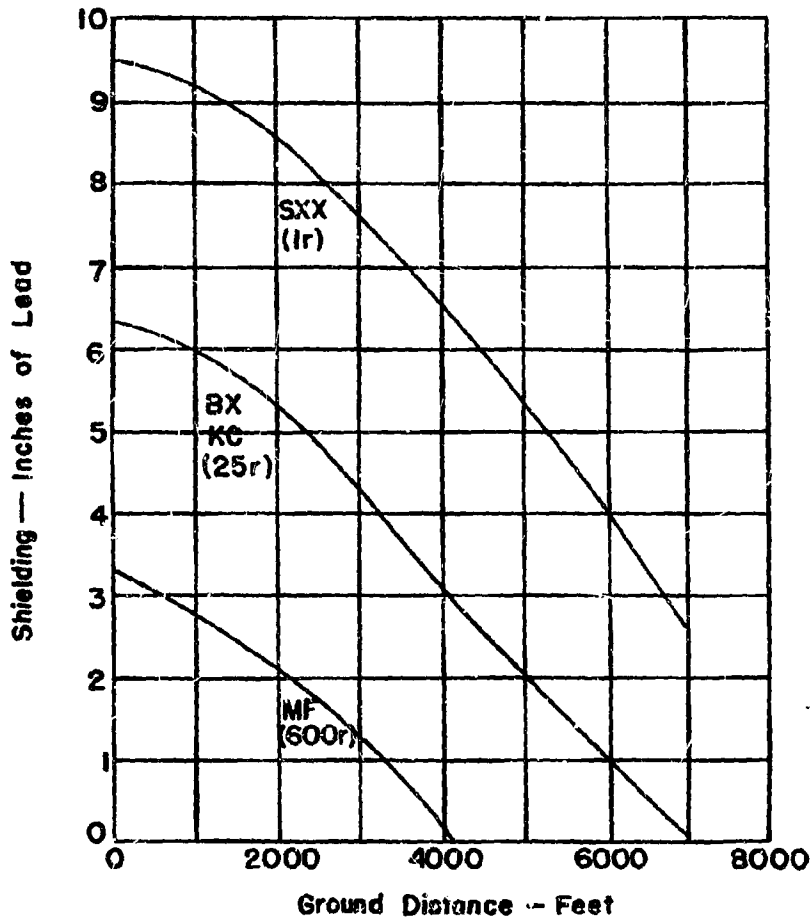

Fig. 2.3 Typical Shielding Curves for Several Films - The above curves are typical and are based on an allowable dosage of prompt gammas of 600 r for Type 918 emulsion (Microfile), 25 r for Background X and Kodachrome and 1 r for Super XX. The allowable dosages are based on tests made by EG&G during Operations TUMBLER-SNAPPER and IVY and represent background fogging equivalent to a density of approximately 0.6. It is to be noted that for any given nuclear detonation particular curves must be plotted using given parameters.

**UNCLASSIFIED**

versus distances to ground zero curves for the several film types used on this operation.

When the shielding requirements were computed, it was decided to shield only against the initial nuclear radiation, and, to simplify the design of the lead shields, no protection was placed in front of the lens. Most camera stations were located so that this lens opening was pointed away from the detonation. In the one exception, those cameras looking at the rear of stations 3.29c and d, a 45 degree mirror was used so that the lens opening would not have to point toward ground zero.

#### 2.3.4 Blast

Aside from the dust which has already been discussed, the principal effect of blast on photography is its effect on the camera itself. Obviously a sturdy camera mount is needed to protect the camera from destruction by the blast and a rigid mount to prevent camera movement, which would occur in most cases at the time of principal interest. A guyed monopole tower was designed to fulfill these requirements, carry the weight of the lead shielding, and elevate the cameras above the dust cloud. For the cameras where the films were to be used for a quantitative analysis of target motion, fixed reference markers were placed in the field of view to determine the camera motion and how to permit its correction.

#### 2.3.5 Illumination

Obtaining proper exposure in zero time photography is complicated by the intense and rapidly varying illumination from the nuclear detonation. Because this illumination varies so greatly in the first few seconds after zero time, film exposed properly at one moment will be overexposed at earlier times and underexposed later, the latitude of most emulsions being too narrow to get proper exposures over the entire range of illumination produced by the atomic detonation. Color film is particularly poor in this respect and for this reason, its use was discouraged as much as possible. ✓

To minimize the effects of the varying illumination, three steps were taken. Type 918 emulsion was selected because of its resistance to nuclear radiation fogging, and was further characterized by exhibiting a wide exposure latitude. Secondly, in almost every case, a backup camera was provided with a different aperture setting. And lastly, most projects were interested only in a definite time of interest, either the thermal or blast arrival. Cameras generally were set for the proper exposure at this interest time and the poor exposures at other times tolerated.

#### 2.4 CHOICE OF CAMERAS

Choice of cameras was tied intimately to choice of picture

frequency or frame rate. A general truism is that resolution goes down as camera frame rate goes up, other parameters being equal. Consequently, in preliminary planning, the frame rates requested by the projects were carefully reviewed and decreased wherever possible. Also, projects were queried as to their need for timing marks along the film, and where the accuracy required was 2 per cent or less, the timing marks requirement was omitted and another method of determining actual frame rate substituted. This method will be described later.

Once the frame rate and timing marks requirements were determined, the choice of most cameras was dictated. For the high speed work, the 16 mm high speed Eastman (E) and the 16 mm Fastax (F) were available in sufficient quantities and were used. Timing marks were available on both of these cameras. For medium speeds, where timing marks were required, the so-called 35 mm high speed Mitchell (MH) was available, and for low and medium speeds where no timing marks were necessary, the choice was the Bell and Howell Gun Sight Aiming Point Camera (GSAP). This latter camera was small and compact and thus easily shielded. It operated from a 24 volt DC governed motor, and new cameras were readily available in quantity at reasonable prices. It was felt that the resolution of the GSAP could be improved with proper collimating and focusing techniques. This was done with a marked degree of success.

For special purposes, the A-5 (A), 35 mm motion picture and the Robot (R), 35 mm still cameras were employed in very small quantities. A complete description of the above cameras is given in Chapter 3.

## 2.5 CHOICE OF FILMS

Project officers, in their photographic requests, specified the type of film they desired as either black and white or color. For reasons stated in sections 2.2.3 and 2.2.5, Eastman Type 918 emulsion was used for the majority of the black and white work. Where light was insufficient either by reason of a high frame rate or poor lighting conditions, a faster emulsion, Eastman Background X was utilized. This had a Weston Index of 24 compared to an index of about 2 for Type 918.

✓ The use of color film was discouraged because of its greater sensitivity to fogging by gamma radiation and its extremely narrow exposure latitude. Many projects required its use nevertheless, particularly where it was desired to observe ignition of fires on objects under test. Consequently, Kodachrome was used only beyond 4000 ft from ground zero where both nuclear radiation and changing illumination constituted less of a hazard than at closer distances.

## CHAPTER 3

### INSTRUMENTATION

#### 3.1 GENERAL

In order that the maximum resolution might be obtained on the films, all of the cameras were collimated on the lens bench before installation in the field. This method of focusing the cameras, rather than using the focusing viewer or index mark on the lens, proved to be worth the extra time involved. After the cameras were collimated the resolution of some individual cameras was increased by as much as 100 per cent.

#### 3.2 MECHANICAL

In order to get above the dust raised by the blasts it was decided to place all cameras on towers. A guyed monopole tower with a small camera platform on top was designed to withstand the expected blast pressures at 2000 ft from ground zero and to support a weight of at least 800 lb. The towers were standardized at three different heights, 6, 11, and 18 ft. Each tower consisted of an 8 in. steel pipe set in a reinforced concrete base. All camera towers over 6 ft high were stabilized by three steel guy wires. A cavity in each concrete base housed the electrical circuitry. All wiring was run inside the concrete box and tower pipe to protect it from the thermal radiation. The concrete base had its top cover set 8 in. above the lake bed to protect it from water in the event of flooding of the lake by rains. All camera mounts for the various types of cameras were designed to fit on the platform on top of this tower. A diagrammatic sketch of a 6 ft camera tower is shown in Fig 3.1.

In general, for distances less than 4000 ft from ground zero only 18 ft towers were installed. This was done in order to get the cameras above the thickest portion of the dust cloud. At distances beyond 4000 ft, lower towers were used, the exact choice depending on the height or size of the object being photographed. The lower tower heights employed closer than 4000 ft to ground zero were selected for the same reason.

Four 25 ft steel frame towers used on previous operations at the Nevada Proving Grounds were also used for special applications. In addition, there were three concrete piers supporting special lead-lined steel boxes. These were used for shielding the high speed Eastman cameras.

Where it was required, lead shields were mounted on the tower platforms to protect the films from nuclear radiation. Because of the difficulty of shielding the larger cameras, generally only GSAP's were used at distances where shielding was needed. Exceptions to this were the three high speed Eastmans mentioned above.

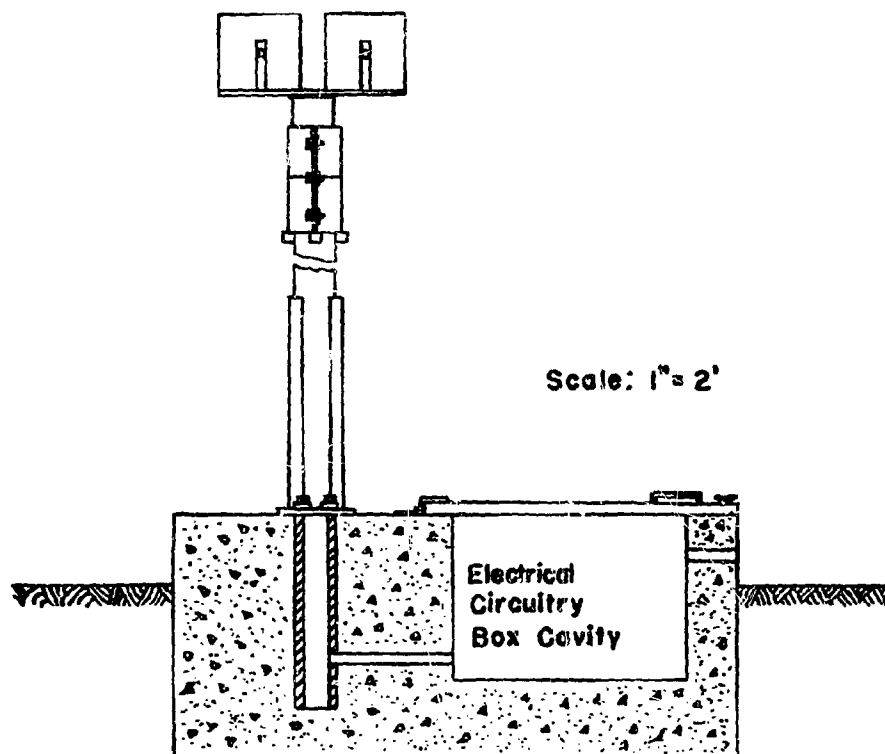

Fig. 3.1 Sketch of an Unguyed 6 Ft Tower - Also shows the sunken reinforced concrete base housing the electrical circuitry equipments used to control the cameras. The design of the towers was standardized and different tower heights were obtained by varying the length of the steel pipe used to support the cameras and associated equipments. All towers over 6 ft high were guyed with three flexible steel wires emanating from a triangular ring welded just below the adjustable sleeve, and terminating in a "never-creep" anchor. The adjustable sleeves were tack welded to prevent rotation of the top plate after the cameras were sighted on the targets.

### 3.3 ELECTRICAL

Electrical circuitry was relatively standard with minor deviations for special purposes. All GSAP cameras were started on a minus 5 sec timing signal. This signal started the cameras and a cam timer which locked itself in after receiving the timing signal. The cam switch applied power to the cameras for the full period of their run. The cam timer then stopped the cameras and, after completing its cycle, stopped itself in position to begin another run. A separate cam turned any auxiliary circuits on and off as was desired. This arrangement, with slight variations, was the pattern for all the various camera stations. Power was supplied to each GSAP-camera station from a 24 volt system of dry cells. Camera stations which required greater power and, in some cases, higher voltages, were operated from small storage batteries.

Timing marks on the films were supplied by a 24 volt, 12 cycle marker generator. This consisted of a 24 volt DC governed motor driving a six-sided cam, the cam breaking an automobile spark coil circuit. Thus a spark or gaseous discharge was furnished in a gap or argon bulb located within the camera, which in turn placed a timing mark on the moving film.

Where AC power was available, crystal controlled 100 cycle or 200 cycle markers were used to provide timing marks. These timing marks provided the accuracy desired by the various projects making quantitative measurements from the films.

### 3.4 PHOTOGRAPHIC

#### 3.4.1 GSAP Cameras

As stated previously, GSAP cameras were chosen because their small size facilitated shielding, they operated on 24 volts DC, they had a governed motor, they were relatively inexpensive, and new cameras were available in the numbers needed. In addition, they were magazine loaded cameras and this facilitated loading.

The stock GSAP camera was furnished with a so-called universal focus lens which was not satisfactory for the type of photographic results desired for this program. These were replaced by the manufacturer with a focusing lens and the camera modified to provide a "C" type lens mount. This change was made because the photography was not all at the effective infinity of the standard lens and also as the quality of the replacement lenses was much better than that of the original equipment.

The cameras as received from the manufacturers were placed on a collimator and the lenses shimmed to give the sharpest focus possible. New fiducial marks were then etched on the lens mounts. The results were most gratifying. Cameras which had given a resolution of approximately 15 lines per millimeter and less before collimating started to give a consistent resolution of from 30 to 50 lines per

millimeter. All cameras were then checked mechanically and electrically and minor adjustments made. As a result of the care given them, the GSAP cameras operated extremely well mechanically on both shots and gave excellent resolution in the field. The GSAP camera and its associated mounting hardware is shown in Fig 3.2.



Fig. 3.2 GSAP Camera and Associated Mounting Hardware

When the camera plan was first conceived, it was decided to place an additional GSAP camera on every tower to furnish a mechanical or electrical backup and to compensate for incorrect exposure calculations. This decision was not carried out completely since it was desirable in many cases for reasons of economy to have each camera of the camera station pair looking at a different object.

#### 3.4.2 High Speed Mitchell

The 35 mm High Speed Mitchell camera is a professional type precision unit capable of frame rates up to 128 frames/sec while retaining the high resolution characteristic of professional motion picture equipment. Optically, it was the ideal camera for all work between



24 and 100 frames/sec on these tests. Its large frame and fine resolution give the maximum amount of information per frame of film, and it is a simple matter to mount a timing light on the housing door in order to obtain timing marks on the side of the film.

Unfortunately, it is a large and expensive piece of equipment and new units are obtainable only in very small quantities. Its larger size also makes lead shielding a more difficult problem. Consequently, no new units were procured for this test and those which were already available were used beyond the distances where shielding was considered to be necessary. The use of this camera was further restricted to stations where quantitative information was desired from the film.

Normally the Mitchell camera is driven by a 115 volt AC-DC motor, but in order to conserve space in the battery box, a 24 volt DC motor was adapted to the camera for this test.

#### 3.4.3 High Speed Eastman

The 16 mm High Speed Eastman camera is of the continuous motion type with a maximum speed of approximately 3000 frames/sec. Image motion compensation is accomplished with a rotating plane prism. The image quality, which is somewhat inferior to that of intermittent motion cameras, is considered very good for a camera of this type. For this operation, cameras were operated at a nominal speed of 500 frames/sec. Timing marks were provided on this camera by the 12 cycle marker circuit.

#### 3.4.4 Fastax

The 16 mm Fastax camera is a continuous motion rotating prism camera similar to the High Speed Eastman camera. For a given frame rate it gives an exposure roughly three times greater than the High Speed Eastman camera, but only at the expense of image quality. These cameras were used where a high frame rate was desired and a low level of illumination available. Timing marks were provided by a 200 cycle crystal controlled marker.

#### 3.4.5 A-5

The A-5 is a 35 mm intermittent motion camera which operates satisfactorily at speeds up to 32 frames/sec. It is fitted with a built-in timing marker and was used in place of the GSAP camera where timing marks were essential. It was also employed in one case where purely pictorial coverage was desired.

#### 3.4.6 Robot

The Robot camera is a 35 mm still camera which can take up to 50 exposures, each 1 in. by 1 in., on a standard cassette loaded with

35 mm film. It is equipped with an automatic film winding-shutter cocking device, which permits, with the aid of a solenoid operated shutter, exposures up to the rate of 5/sec.

3.4.7 Summary

Table 3.1 is a tabulated summary of the characteristics of all cameras employed on this operation.

TABLE 3.1 - Summary of Camera Characteristics

Camera	Shutter Opening	Maximum Speed (Frames/Sec.)	Power Requirements	Timing Markers Used
High Speed Mitchell 35 mm	15° - 170° Sector	128	115 V AC-DC 24 V DC (Special)	100 cps 12 cps
A-5 35 mm	120° Sector	32	24 V DC	2 cps
GSAP 16 mm	133° Sector	64	24 V DC	None
High Speed Eastman 16 mm	20% Prism	3,000	115 V DC	12 cps
Fastax 16 mm	60% Prism	10,000	115 V AC-DC	200 cps
Robot-35 mm (Still)	-	-	24 V DC	Clock

## CHAPTER 4

### OPERATIONS

#### 4.1 GENERAL

The magnitude of this project from the drawing board to the operation of the cameras in the field can best be realized by bare statistics. On Shot 9 a total of 193 cameras of various types were operated, ranging in frame rates from 2 frames/min to 2500 frames/sec. A total of 100 separate camera towers were erected to mount these cameras, and two full days were required merely to load the film. On Shot 10 a total of 94 cameras were operated from 50 camera towers. A summary of the cameras employed is tabulated in Table 4.1.

#### 4.2 PREPARATION

The mechanical and electrical equipments were so designed and constructed that their installation and testing in the field required a minimum amount of time, tools, and equipment. The actual construction of the equipment, and the final testing, was done before moving the components from Las Vegas to the field. This action proved to be the best procedure because of the frequent dust storms in the field, which on several occasions necessitated the complete shutdown of field operations. A Butler building erected by a project for study at 20,000 ft from ground zero was used by this project as a workshop. Without this the field work would have been most difficult.

#### 4.3 INSTALLATION OF EQUIPMENT

The equipment components, namely, circuit box, shielding and camera, were installed by specialized electrical, mechanical, and photographic teams. Check sheets were made for each operation and the teams were required to follow them implicitly. These procedures were necessary, and worked well, considering the number of individual operations required to operate such a large number of cameras.

In order to work on the higher towers efficiently, special equipments were designed and built or procured commercially. These consisted of pick-up trucks upon which were fabricated special platforms 10 ft above the ground. Three of these "platform-loaders" were used to service the 10 ft towers. Two airplane loaders were procured and modified to service the 17 ft towers. These plane loaders were essentially fork lifts with a platform built over the forks. An electrically driven chain hoist, which was used for installing and removing 300 lb lead shields, was mounted on a channel beam above the platform.

TABLE 4.1 - Summary of Cameras Employed

Camera	Shot 1	Shot 4	Shot 9	Shot 10	Shot 11
High Speed Mitchell 35 mm	4	2	15	12	4
A-5 35 mm	0	0	4	0	0
GSAP 16 mm	0	0	162	71	0
High Speed Eastman 16 mm	0	0	8	7	0
Fastax 16 mm	0	0	2	2	0
Robot 35 mm	0	0	2	2	0
Total	4	2	193	94	4

The majority of the vehicles were radio equipped which helped to speed up operations and also permitted fewer specialized teams. Each tower was assigned an EG&G station number for identification purposes and in all field work these numbers were used as references. (See Table B.1.)

#### 4.4 PRE-SHOT OPERATIONS

On completion of the installation of the camera stations all cameras were loaded, and a complete dry run was held. A camera dry run was not held on the day of the formal dry run inasmuch as there would not have been time to process the films and make any necessary repairs or adjustments. The camera dry run gave a check on the mechanical and electrical operations, the camera alignments, and some information on exposures. Two days were allowed following this dry run to make the necessary repairs and adjustments before the cameras were loaded for the live run.

Throughout the entire operation all cameras were covered by plastic bags once they were installed. It was necessary to remove these plastic bags each time a camera was worked on, loaded or run, but in view of the terrific dust storms these bags proved well worth

**UNCLASSIFIED**

the extra effort. Figure 4.1 shows a camera station covered with a plastic bag.



Fig. 4.1 Camera Station Covered with Plastic Bag

It required two full days to load all the cameras and install the lead shields for Shot 9. When Shot 9 was postponed for one day it was believed that all the films might have to be replaced inasmuch as the ambient temperatures within the cameras rose to a measured 118°F. However, no noticeable effects were discovered upon processing.

For Shot 10 only one day was required for the camera loading operation. As the high temperatures did not have any noticeable adverse effects on the films from Shot 9, it was decided that unless there was a delay of 5 days or more, new films would not be placed in

the cameras. Thus reloading was not required as Shot 10 was detonated as scheduled. Figure 4.2 shows an unshielded camera installation. The aluminum covers are for thermal protection as are the goose neck connectors.



Fig. 4.2 Unshielded Camera Installation

#### 4.5 REFERENCE MARKERS

At those camera stations where a quantitative analysis of the films would be made, a reference marker was erected in front of the camera. These markers were of varying lengths of 6 in. steel pipes, available from salvage, mounted in a concrete base. The markers were placed within the field of view of the camera and generally to one side of the target. The markers were left unpainted to prevent the

smoke caused by the thermal radiation from obscuring the target. The makers may seem to be overdesigned insofar as blast pressures are concerned.

#### 4.6 FILM RECOVERY

Recovery of the films was done on shot day following R-hour by the same teams and equipment used for loading. All films exposed during Shot 9 were free from nuclear radiation fogging, thus proving the adequacy of the lead shields. On Shot 10 some 14 films were fogged from the nuclear radiation, and in each case these films were in cameras which were blown away from the camera towers by the blast wave. In several cases the cameras were blown over 1500 ft from their original location without apparent damage except for the fogging of the films.

#### 4.7 PROCESSING AND PRINTING

Processing of all films except Kodachrome was done by EG&G at Las Vegas. Kodachrome was processed by the Eastman Kodak Co. at Los Angeles. Prints for original distribution were made at the Consolidated Film Industries Laboratories and Cinema Research Corporation, both of Hollywood, Calif. Where necessary, controlled prints were made; that is, changes in the density of the film as the illumination from the bomb changed were compensated for in the printing in an effort to bring out the maximum amount of information possible on the print. Consequently, these prints should not be used for photometric purposes. Each film was inspected before being printed and all footage containing dust was removed. No frames were removed where any intelligence was visible through the dust, no matter how great the intensity of the dust.

## CHAPTER 5

### RESULTS

#### 5.1 GENERAL

Considering this project from a photographic standpoint only, the results were highly gratifying to all who contributed to the implementation of the photographic plan. The final judgment of the success or failure, to whatever degree, of this project as a whole must be made at a later date by the various projects for whom the photography was performed. This judgment will come when the films have been analyzed and compared with other methods of scientific instrumentation.

#### 5.2 CAMERA OPERATION

The breakdown of the equipment failures for various causes is tabulated by shots in Tables 5.1 and 5.2. It should be noted that failures attributed to film jamming cannot be resolved into any particular causes. However, in every case where a film jam occurred the cameras were operated immediately on unloading and operated normally. All cameras operated normally before they were loaded.

From an electrical and mechanical standpoint, the successful operation of the cameras on Shot 9 was 99 per cent while on Shot 10 it was 96 per cent. If the towers which were destroyed on Shot 10 were counted as camera failures then this latter figure would be reduced to 76 per cent. From the author's viewpoint these figures are most gratifying, and justify all the extra effort by all concerned to insure the success of this project.

Camera towers installed close-in on Shot 10 were blown down and in many cases the cameras were blown considerable distances. These cameras were subjected to high gamma radiation when they were blown free of their lead shields and all films exposed in this area were so badly fogged by this radiation that they were considered worthless and were not printed. In addition even without the radiation these films would have been useless because of the early tower destruction.

#### 5.3 PHOTOGRAPHIC HAZARDS

##### 5.3.1 Dust

The dust problem on this project proved to be even worse than was originally anticipated since the normally hard surface of the dry

**UNCLASSIFIED** **CONFIDENTIAL**  
**UNCLASSIFIED**



TABLE 5.1 - Breakdown of Equipment Failures - Shot 9

Camera Data		Camera Failures				Towers Damaged	Rad <sup>3</sup>	Total Failure
Type	No	Mech <sup>1</sup>	Elec <sup>2</sup>	Film	Markers			
Mitchell	15	0	0	0	0	0	0	0
Kastman	8	0	0	0	0	0	0	0
Fastax	2	0	0	0	2	0	0	2
A-5	4	0	0	0	0	0	0	0
GSAP	162	0	0	2	0	0	0	2
Robot	2	0	0	0	0	0	0	0
Total	193	0	0	2	2	0	0	4

- 1 Mech - Mechanical Failure of camera.
- 2 Elec - Failure of station electrical circuit.
- 3 Rad - Film not usable because of radiation fogging.

TABLE 5.2 - Breakdown of Equipment Failure - Shot 10

Camera Data		Camera Failures				Towers Damaged	Rad <sup>3</sup>	Total Failure
Type	No	Mech <sup>1</sup>	Elec <sup>2</sup>	Film	Markers			
Mitchell	12	0	0	2	1	0	0	3
Kastman	7	0	0	0	0	0	0	0
Fastax	2	0	0	0	0	0	0	0
A-5	-	-	-	-	-	-	-	-
GSAP	71	0	0	0	0	10	14	14
Robot	2	1	0	0	0	0	0	1
Total	94	1	0	2	1	10	14	18

- 1 Mech - Mechanical Failure of camera.
- 2 Elec - Failure of station electrical circuit.
- 3 Rad - Film not usable because of radiation fogging.

lake bed was churned to an extremely fine powder by so many vehicles and so much heavy equipment. In addition the area was drier at the time of the test than would normally be expected, because there was practically no rainfall for the two and a half month period prior to the tests. In those areas where the lake bed was not so badly cut up the best photography was obtained as far as the dust hazard was concerned. The Project 8.1 aircraft areas are good examples. In most other cases the measures taken to combat dust proved very satisfactory. The stabilization program contributed immeasurably to the success of the photographic program. Those projects which were interested in the thermal effects only, obtained most satisfactory results, while those projects whose primary interest was during the blast phase obtained, in most cases, quite good results before the dust obscured the entire field of view of the camera. In addition, there is no question but that the concept of elevated cameras on stabilized areas was proven.

#### 5.3.2 Thermal Radiation

The effects of thermal radiation were anticipated and generally forestalled insofar as the camera towers were concerned. Not enough emphasis was placed by the projects on preventing the object being photographed from smoking on exposure to the thermal radiation. Much information was lost from this hazard. This obscured targets in some cases to a greater degree than the dust.

#### ✓ 5.3.3 Nuclear Radiation

Nuclear radiation caused no loss of data on the films exposed during Shot 9. In isolated cases there was insignificant fogging of the film. However, the protective measures taken were entirely satisfactory and completely adequate.

On Shot 10 there were 14 films ruined from nuclear radiation. In each case the lead shields were separated from the camera when the towers were blown over by the blast wave. These films were so badly fogged that they were destroyed and not printed. In addition even without the radiation, these films would have been useless because of the early tower destruction.

#### 5.3.4 Blast

On Shot 9 there were no difficulties encountered attributable to the blast wave. The camera towers proved exceedingly rigid and in cases where there was a small amount of tower movement, only a barely perceptible blurring of the image at 64 frames/sec is noticeable, and then only for two or three frames.

The blast wave from Shot 10 destroyed all camera towers within about a half mile of ground zero despite the fact that towers had been tested previously at the pressures encountered on Shot 10. The

UNCLASSIFIED

~~CONFIDENTIAL~~

exact peak overpressures expressed in psi are meaningless in the case of Shot 10, apparently because of the nature of the blast wave phenomenon. This information is offered without comment and the reader is referred to the reports of the Technical Director and Program 1 for an analysis of the blast wave from this shot.

#### 5.3.5 Illumination

Exposures in general were quite good. However, the Kodachrome film, as was expected, did not have sufficient latitude to allow for normal errors in computing exposures and the rapidly changing illumination. Thus, some of the films were rather poorly exposed for correct color balance though perfectly usable.

#### 5.4 PICTURE QUALITY

The quality of the pictures obtained was generally excellent, and in the cases of the GSAP and High Speed Eastman cameras, outstanding for those types of cameras. It was feared that severe scratching might be encountered due to the exceedingly dusty working conditions, but scratching was not excessive even for those cameras running at relatively high speeds. The quality of the pictures taken with GSAP cameras was actually outstanding and justified the tedious work which was expended on the lens bench with these cameras.

## CHAPTER 6

### CONCLUSIONS AND RECOMMENDATIONS

#### 6.1 CONCLUSIONS

Support for the general conclusions relating to the technical photography for this operation is contained in the main body of this report, and on the films which have been delivered to the various agencies associated with UPSHOT-KNOTHOLE.

It is concluded that:

1. Zero time technical photography of the effects of the blast phenomenon and the thermal radiation on test objects is feasible.
2. Zero time technical photography of the blast wave and shock front is an excellent form of scientific instrumentation, particularly in the case of a larger than nominal sized nuclear weapon.
3. The methods, equipments and circuitry developed for this project operated very satisfactorily, and the mechanical and electrical failures were a minimum.

#### 6.2 RECOMMENDATIONS

It is recommended that on future operations of this nature:

1. The photographic planning be started at an early date, and that the project requirements be screened thoroughly to eliminate photography purely of a non-technical documentary nature in a technical photography project.
2. The use of methods, equipments and circuitry developed for this operation be considered.
3. A "camera line" be established, that stabilization be provided in a continuous strip along this line, and that all photography be accomplished on this stabilized "camera line."
- ✓ 4. Both camera and camera target be elevated wherever possible to get above the inherent dust.
5. Wherever possible all camera targets, guy wires and other combustible materials have all the paint, dirt, and grease removed to prevent thermal smoking. If targets must be painted, a fire-resistant paint should be used.
- ✓ 6. Photography should not be attempted at a distance closer than approximately 2500 ft from ground zero for a nominal nuclear detonation unless the information required is so important as to warrant the tremendously increased effort and expense necessary.
- ✓ 7. Color film be used with caution because of its very poor latitude to varying illumination.

## APPENDIX A

### FILM DATA SHEETS

#### A.1 GENERAL

The intention of Appendix A is to list and explain the symbols, numbering system and abbreviations contained in the film data sheets and sketches which are inserted throughout this report.

#### A.2 CAMERAS

##### A.2.1 Types Used

The cameras which were used on this project are identified as follows:

- E - 16 mm High-Speed Eastman Camera.
- MH - 35 mm High-Speed Mitchell Camera.
- A-5 - 35 mm Standard U. S. Air Force A-5 Camera.
- F - 16 mm High-Speed Fastax Camera.
- R - 35 mm Robot Camera.
- G - 16 mm Gun Sight Aiming Point Camera.

The EG&G serial number of a particular camera follows the camera symbol given above. Thus MH-16 signifies a 35 mm High Speed Mitchell camera whose serial number is 16.

##### A.2.2 Vertical Angle

The vertical angle is the angle of depression (or elevation) of the optical axis of the camera with reference to the horizontal. This angle is accurate to within plus or minus 0.5 degrees.

##### A.2.3 Frames/Second

The frame rate was determined from the shock arrival time at each project station (or in some instances the camera station). It is suggested that where any unusual speeds are given the project check these results as in some cases the exact project location was not known.

**UNCLASSIFIED**

### A.3 TIMING MARKERS

Two types of timing mark generators were used on this test to place timing marks on film.

#### A.3.1 100 and 200 Cycles/Sec Markers

These are crystal controlled markers furnishing an electronically amplified signal. They place a sharp mark on a strip of film with an accuracy limited only by the flutter of the film as it rides past the marker head in the camera. In general, this accuracy is greater than that to which the film can be read dimensionally.

These markers would have been used in every case except that their size, cost, and requirement for AC power precluded their use at most camera stations.

#### A.3.2 2 and 12 Cycles/Sec Markers

These are 24 volt DC markers consisting of a small governed motor driving a cam which breaks a circuit containing an automobile spark coil. These markers generate a marker frequency that is approximately 12 cycles/sec but is slightly different for each one. Therefore, each marker was individually calibrated and its average frequency marked on it. These frequencies were found to range from 11.50 to 11.95 cycles/sec. The calibrations are shown on the film data sheets and are accurate to  $\pm 0.25$  per cent.

It has been found that short time intervals are recorded with less accuracy than longer periods. Time measurements made from the timing marks have been found to have the following accuracies:

No. of Successive Periods	Accuracy
1	$\pm 2.5\%$
2	$\pm 1.5\%$
3	$\pm 0.8\%$
6	$\pm 0.4\%$
9	$\pm 0.3\%$
12 or more	$\pm 0.25\%$

For example, marker Serial No. 8 has a nominal frequency of 11.73 cycles/sec. Therefore:

$$\text{One period} \pm \frac{1}{11.73} (1 = 0.025) = 0.0853 \pm 0.00213 \text{ sec.}$$

In some cases these markers make a series of marks, closely spaced, on the film. This is a normal phenomenon due to the unsurpassed spark discharge and introduces no additional error. Care must be taken though to read from the first mark in one series to the first mark in the next.

#### A.4 FILM

##### A.4.1 Types Used

The various emulsions referred to throughout this report are as follows:

MF - Special Order Eastman Kodak film (Type 916 Emulsion).  
Also sometimes erroneously referred to as "Microfile."

KC - Eastman Kodachrome - Daylight Type.

BU - Eastman Background X.

##### A.4.2 Numbers

The film number refers to the particular film for each camera and must be used whenever additional prints are desired.

#### A.5 FILTERS

ND-1 refers to a neutral density filter (flat spectral response) having an optical density of 1 or a transmission of 0.1. The symbol W-12 refers to a Wratten 12 or minus blue filter, and K-2 refers to a Kodak yellow filter.

#### A.6 TOWERS

The nominal height which the cameras were mounted above the ground is shown in this report as tower height. This distance is accurate to within plus or minus 6 in.

#### A.7 PRINTS

##### A.7.1 Distribution

Nine prints were made from each original negative and these prints were distributed as follows:

2 Prints - Chief, AFSWP, Washington, D. C.

2 Prints - DWET, Albuquerque, New Mexico

- 1 Print - Interested Project
- 1 Print - LASL, Los Alamos, New Mexico
- 1 Print - EG&G, Boston, Massachusetts
- 2 Prints - EG&G, Las Vegas, Nevada

One of the two prints retained by EG&G in Las Vegas is the fine grain positive of the original negative from which additional prints may be made if necessary. The original negative will eventually be filed at Lookout Mountain Laboratory.

A.7.2 Identification

The leader of all release prints identifies the various films according to the classified code name of the particular shot. The correlation of this code name with the shot number is given below:

<u>Shot No</u>	<u>Code Name</u>
1	ANNIE
4	DIXIE
9	ENCORE
10	GRABLE
11	CLIMAX

A.8 PHOTOGRAPHIC STATION DESIGNATION

The relationship between the various project numbers and the EG&G camera station designations is shown in Table A.1.

**UNCLASSIFIED**



TABLE A.1 - Designation of Photographic Station

Project No.	Photographic Designation		EG&G No.
	Agency	Short Title	
1.2	NOL	"Blast"	9.1
3.5	WADC	"Panels"	9.2
3.6	TC, WADC	"Railroad"	9.3
3.16	BuDocks	"Glazing"	9.4
3.19	USDA	"Forest"	9.5
3.21	BRL	"Vehicles"	9.6
3.22	EROL	"Bridge"	9.7
3.26.1	AMC	"POL"	9.8
3.26.2	QMC	"POL"	9.9
3.27	MC	"Tents"	9.16
3.29	FCDA	"Structures"	9.10
8.1	WADC	"Structures"	9.11
8.4	GWS	"Smoke"	9.12
8.5	QMC	"Pigs"	9.13
8.11	USDA	"Houses"	9.14
9.1	AFSWP	"Training Film"	9.15
9.7	AFSWP	"Stabilization"	9.17

The above table illustrates the basis of the EG&G photo station designation system. All photo stations are indicated by the number 9, followed by a period. The number following the period identifies the project. The individual stations for a project are identified by lower case letters, with the station closest to ground zero generally being station "a" and so forth.

## APPENDIX B

### SHOT 9 CAMERA STATIONS

#### B.1 GENERAL

The photographic plan as implemented on Shot 9 is set forth in this appendix. Preceding this plan is a summary of the cameras giving in detail the various camera parameters which may be useful to individual project personnel for a detailed analysis of their film.

#### B.2 FORM

Preceding the camera layout sketches is a short resume of the photographic coverage of the project.

The project resume is divided into four sections, namely, purpose, scope, treatment, and comment. This resume should be digested by the reader before making any analysis of the project photography. In addition, any unusual events which were noticed by the authors are recorded as comments.

TABLE B.1 - Shot 9 Camera Data

Project No	EG&G Sta.	Camera Data						
		Type & No	Focus (Ft)	Aperture (f-Stop)	Frames/Second	Filter		Marker (cps)
						ED	W	
1.2	9.1a	E-7	Inf	11.0	537	-	-	11.94
1.2	9.1a	E-17	Inf	4.0	441	-	-	11.93
1.2	9.1b	MH-15	Inf	11.0	102	-	12	100
1.2	9.1b	MH-16	Inf	5.6	98	-	-	100
1.2	9.1b	MH-4	Inf	5.6	97	-	12	100
1.2	9.1c	MH-11	Inf	2.7	100	-	12	11.60
1.2	9.1c	MH-17	Inf	2.7	96	-	12	11.65
1.2	9.1d	MH-8	Inf	2.3	103	-	12	11.52
1.2	9.1e	MH-14	Inf	2.7	108	-	12	100
1.2	9.1f	MH-19	Inf	2.8	102	-	12	100
1.2	9.1f	MH-15	Inf	8.0	98	-	12	100
1.2	9.1f	MH-24	Inf	8.0	97	1	12	100
3.5a	9.2i	G-12	Inf	2.5	60	-	-	-
3.5a	9.2i	G-16	Inf	2.5	64	-	-	-
3.5b	9.2h	G-178	Inf	2.5	65	-	-	-
3.5b	9.2h	G-15	Inf	2.5	62	-	-	-
3.5aa	9.2f	G-170	Inf	2.5	67	-	-	-
3.5aa	9.2f	G-185	Inf	2.5	64	-	-	-
3.5ba	9.2c	G-159	Inf	2.5	65	-	-	-
3.5ba	9.2c	G-160	Inf	2.5	59	-	-	-
3.5bc	9.2e	G-162	Inf	2.5	63	-	-	-
3.5bc	9.2e	G-164	Inf	2.5	67	-	-	-
3.16a	9.4a	F-5	18	2.0	2500	-	-	200
3.16a	9.4a	G-1	18	2.5	61	-	-	-
3.16a	9.4b	F-15	18	2.0	2500	-	-	200
3.16a	9.4b	G-2	18	2.5	59	-	-	-
3.16b	9.4c	G-4	10	5.6	65	-	-	-
3.16b	9.4c	G-26	10	8.0	65	-	-	-
3.19	9.5b	MH-7	Inf	2.3	87	-	-	11.40
3.19	9.5c	MH-3	Inf	2.3	94	-	-	11.75
3.19	9.5d	MH-13	Inf	2.3	27	-	-	11.68
3.19	9.5e	MH-21	Inf	2.3	83	-	-	11.75
3.19	9.5e	MH-22	Inf	2.3	96	-	-	11.73
3.19	9.15a	A-3	75	4.0	33	-	-	-
3.19	9.15a	A-10	75	2.3	30	-	-	-

~~CONFIDENTIAL~~  
UNCLASSIFIED

TABLE B.1 (Continued)

Project No	EG&G Sta.	Camera Data						
		Type & No	Focus (Ft)	Aperture (f-Stop)	Frames/Second	Filter		Marker (cps)
						ND	W	
3.20	9.3d	G-18	Inf	3.5	65	-	-	-
3.20	9.3d	G-22	Inf	3.5	64	-	-	-
3.21e	9.6a	G-29	Inf	11.0	63	-	-	-
3.21e	9.6a	G-13	Inf	5.6	62	-	-	-
3.21i	9.6b	G-31	Inf	8.0	61	-	-	-
3.21i	9.6b	G-14	Inf	4.0	63	-	-	-
3.21k	9.6c	G-33	Inf	2.5	65	-	-	-
3.21k	9.6c	G-17	Inf	2.5	67	-	-	-
3.21m	9.6d	G-34	Inf	2.5	62	-	-	-
3.21m	9.6d	G-75	Inf	2.5	62	-	-	-
3.22b	9.7a	G-122	Inf	2.8	33	-	-	-
3.22b	9.7a	G-101	Inf	2.5	32	-	-	-
3.22b	9.7b	A-26	75	4.0	24	-	-	1.94
3.22b	9.7b	A-16	75	2.3	24	-	-	1.96
3.24d	9.15c	G-121	45	5.6	65	-	-	-
3.26.1aa	9.15c	G-124	45	2.5	65	-	-	-
3.26.1aa	9.8h	G-171	48	8.0	60	-	-	-
3.26.1aa	9.8h	G-46	Inf	4.0	63	-	-	-
3.26.1ac	9.8e	G-152	50	5.6	65	-	-	-
3.26.1ac	9.8e	G-30	Inf	2.5	63	-	-	-
3.26.1af	9.8b	G-116	54	11.0	64	-	-	-
3.26.1af	9.8b	G-183	Inf	2.5	63	-	-	-
3.26.1aj	9.8i	G-176	Inf	8.0	63	-	-	-
3.26.1aj	9.8i	G-68	Inf	4.0	52	-	-	-
3.26.1al	9.8f	G-98	50	5.6	63	-	-	-
3.26.1al	9.8f	G-25	Inf	2.5	61	-	-	-
3.26.1au	9.8a	G-78	52	11.0	60	-	-	-
3.26.1au	9.8a	G-27	Inf	2.5	64	-	-	-
3.26.1au	9.8j	G-49	Inf	2.5	64	-	-	-
3.26.1au	9.8j	G-50	Inf	2.5	65	-	-	-
3.26.1av	9.8k	G-52	Inf	2.5	65	-	-	-
3.26.1av	9.8k	G-55	Inf	2.5	100	-	-	-
3.26.1ax	9.8g	G-45	Inf	3.5	58	-	-	-
3.26.1ax	9.8g	G-45	Inf	2.5	63	-	-	-
3.26.1ay	9.8d	G-39	Inf	11.0	66	-	-	-

TABLE B.1 (Continued)

Project No	KG&G Sta.	Camera Data						
		Type & No	Focus (Ft)	Aperture (f-Stop)	Frames/Second	Filter		Marker (cps)
						ND	W	
3.26.1ay	9.8d	G-39	Inf	2.5	65	-	-	-
3.26.1ass	9.8c	G-182	Inf	11.0	67	-	-	-
3.26.1asz	9.8c	G-36	Inf	2.5	66	-	-	-
3.26.1bb	9.8n	G-61	33	8.0	61	-	-	-
3.26.1bb	9.8n	G-62	33	5.6	63	-	-	-
3.26.1bc	9.8o	G-89	52	8.0	M*	-	-	-
3.26.1bc	9.8o	G-77	52	5.6	65	-	-	-
3.26.1bd	9.8m	G-54	60	2.5	60	-	-	-
3.26.1bd	9.8m	G-57	58	2.5	58	-	-	-
3.26.1be	9.8l	G-47	36	2.5	61	-	-	-
3.26.1be	9.8l	G-53	36	2.5	65	-	-	-
3.26.2da-2	9.9a	G-64	35	5.6	32	-	-	-
3.26.2da-2	9.9a	G-66	35	2.5	34	-	-	-
3.26.2db-2	9.9e	G-84	35	11.0	31	-	-	-
3.26.2db-2	9.9e	G-85	35	8.0	32	-	-	-
3.26.2dc-2	9.9i	G-95	35	8.0	32	-	-	-
3.26.2dc-2	9.9i	G-96	35	5.6	32	-	-	-
3.26.2da-3	9.9b	G-72	40	5.6	31	-	-	-
3.26.2da-3	9.9b	G-73	40	2.5	31	-	-	-
3.26.2db-3	9.9f	G-86	40	11.0	32	-	-	-
3.26.2db-3	9.9f	G-87	40	5.6	31	-	-	-
3.26.2dc-3	9.9j	G-99	40	8.0	31	-	-	-
3.26.2dc-3	9.9j	G-108	40	4.0	31	-	-	-
3.26.2da-7	9.9c	G-74	32	5.6	33	-	-	-
3.26.2da-7	9.9c	G-76	32	2.5	33	-	-	-
3.26.2db-7	9.9g	G-88	32	11.0	32	-	-	-
3.26.2db-7	9.9g	G-91	32	8.0	31	-	-	-
3.26.2dc-7	9.9k	G-103	32	8.0	33	-	-	-
3.26.2dc-7	9.9k	G-104	32	5.6	31	-	-	-
3.26.2da-9	9.9d	G-81	23	5.6	32	-	-	-
3.26.2da-9	9.9d	G-83	23	2.5	32	-	-	-
3.26.2db-9	9.9h	G-92	23	11.0	32	-	-	-
3.26.2db-9	9.9h	G-93	23	5.6	32	-	-	-
3.26.2dc-9	9.9l	G-105	23	8.0	33	-	-	-
3.26.2dc-9	9.9l	G-106	23	4.0	31	-	-	-

~~TOP SECRET~~  
UNCLASSIFIED

TABLE B.1 (Continued)

Project No	EG&G Sta.	Type & No	Camera Data					
			Focus (Ft)	Aperture (f-Stop)	Frames/Second	Filter		Marker (cps)
						ND	W	
3.26.3	9.31	G-21	Inf	4.0	64	-	-	-
3.26.3	9.31	G-24	Inf	2.5	64	-	-	-
3.27a	9.16a	G-125	Inf	5.6	68	-	-	-
3.27a	9.16a	G-187	Inf	4.0	67	-	-	-
3.27b	9.16b	G-161	Inf	4.0	63	-	-	-
3.27b	9.16b	G-165	Inf	4.0	61	-	-	-
3.27c	9.16c	G-179	Inf	4.0	65	-	-	-
3.27c	9.16c	G-180	Inf	4.0	65	-	-	-
3.29a	9.10k	G-128	Inf	2.5	66	-	-	-
3.29a	9.10k	G-129	Inf	2.5	64	-	-	-
3.29a	9.10l	G-131	Inf	2.5	63	-	-	-
3.29a	9.10l	G-134	Inf	2.5	58	-	-	-
3.29a	9.10m	G-135	Inf	2.5	-	-	-	-
3.29a	9.10m	G-136	Inf	2.5	60	-	-	-
3.29a	9.10n	G-137	Inf	2.5	58	-	-	-
3.29a	9.10n	G-139	Inf	2.5	62	-	-	-
3.29a	9.10o	G-141	Inf	4.0	67	-	-	-
3.29a	9.10o	G-143	Inf	4.0	69	-	-	-
3.29a	9.10p	G-145	Inf	4.0	64	-	-	-
3.29a	9.10p	G-147	Inf	4.0	61	-	-	-
3.29a	9.10q	G-148	Inf	4.0	62	-	-	-
3.29a	9.10q	G-149	Inf	4.0	64	-	-	-
3.29a	9.10r	G-151	Inf	4.0	65	-	-	-
3.29b	9.10s	G-154	Inf	2.5	57	-	-	-
3.29b	9.10s	G-155	Inf	2.5	64	-	-	-
3.29b	9.10t	G-156	Inf	2.5	63	-	-	-
3.29b	9.10t	G-140	Inf	2.5	62	-	-	-
3.29c	9.10a	G-51	Inf	2.5	62	-	-	-
3.29c	9.10a	G-56	Inf	2.5	60	-	-	-
3.29c	9.10b	G-59	Inf	2.5	61	-	-	-
3.29c	9.10b	G-60	Inf	2.5	61	-	-	-
3.29c	9.10c	G-63	Inf	2.5	62	-	-	-
3.29c	9.10c	G-65	Inf	2.5	62	-	-	-
3.29c	9.10d	G-102	Inf	2.5	58	-	-	-
3.29c	9.10d	G-97	Inf	2.5	59	-	-	-

**UNCLASSIFIED**

TABLE B.1 (Continued)

Project No	EG&G Sta.	Camera Data						
		Type & No	Focus (Ft)	Aperture (f-Stop)	Frames/Second	Filter		Marker (eps)
						ND	W	
3.29c	9.10e	G-82	Inf	4.0	66	-	-	-
3.29c	9.10e	G-94	Inf	4.0	67	-	-	-
3.29c	9.10f	G-110	Inf	4.0	65	-	-	-
3.29c	9.10f	G-111	Inf	4.0	65	-	-	-
3.29c	9.10g	G-112	Inf	4.0	58	-	-	-
3.29c	9.10g	G-114	Inf	4.0	61	-	-	-
3.29c	9.10h	G-115	Inf	4.0	64	-	-	-
3.29c	9.10h	G-117	Inf	4.0	64	-	-	-
3.29d	9.10i	G-118	Inf	2.5	65	-	-	-
3.29d	9.10i	G-119	Inf	2.5	64	-	-	-
3.29d	9.10j	G-123	Inf	2.5	63	-	-	-
3.29d	9.10j	G-126	Inf	2.5	62	-	-	-
8.1B	9.11f	E-2	17	2.8	606	-	-	11.80
8.1B	9.11f	G-130	17	5.6	64	-	-	-
8.1B	9.11g	E-14	12	5.6	531	-	-	11.80
8.1B	9.11g	G-138	12	5.6	63	-	-	-
8.1B	9.11h	E-19	17	2.8	563	-	-	11.66
8.1B	9.11h	G-146	17	8.0	62	-	-	-
8.1L	9.11a	G-67	Inf	5.6	65	-	-	-
8.1L	9.11a	G-70	Inf	5.6	49	-	-	-
8.1L	9.11b	E-4	25	1.9	444	-	-	11.85
8.1M	9.11c	G-181	45	5.6	64	-	-	-
8.1M	9.11c	G-120	45	5.6	61	-	-	-
8.1M	9.11d	E-21	25	2.8	578	-	-	11.68
8.1M	9.11e	E-15	25	2.8	478	-	-	11.54
8.5a	9.13a	G-42	32	8.0	69	-	-	-
8.5a	9.13a	G-58	32	4.0	62	-	-	-
8.5c	9.13c	G-71	32	8.0	56	-	-	-
8.5c	9.13c	G-100	32	4.0	55	-	-	-
8.5d	9.13d	G-142	32	5.6	66	-	-	-
8.5d	9.13d	G-144	32	2.5	69	-	-	-
8.11a	9.14a	G-157	Inf	16.0	17	-	-	-
8.11a	9.14a	G-5	Inf	11.0	17	-	-	-
8.11a	9.14b	G-127	Inf	11.0	16	-	-	-
8.11a	9.14b	G-6	Inf	11.0	16	-	-	-

~~CONFIDENTIAL~~  
**UNCLASSIFIED**

TABLE B.1 (Continued)

Project No	EC&F Sta.	Camera Data						
		Type & No	Focus (Ft)	Aperture (f-Stop)	Frames/Second	Filter		Marker (cps)
						MD	W	
8.11a	9.14e	G-174	23	4.0	64	-	-	-
8.11a	9.14e	G-10	23	4.0	64	-	-	-
8.11b	9.14c	G-7	Inf	11.0	16	-	-	-
8.11b	9.14c	G-11	Inf	11.0	16	-	-	-
8.11b	9.14d	G-166	Inf	11.0	17	-	-	-
8.11b	9.14d	G-9	Inf	11.0	16	-	-	-
9.1G	9.15a	G-107	43	8.0	64	-	-	-
9.1G	9.15a	G-133	43	4.0	66	-	-	-
9.7a	9.17a	G-167	32	5.6	64	1	-	-
9.7a	9.17a	G-168	32	5.6	71	-	-	-
9.7b	9.17b	G-169	32	5.6	64	1	-	-
9.7b	9.17b	G-172	32	5.6	66	-	-	-
9.7c	9.17c	G-173	32	11.0	65	-	-	-
9.7c	9.17c	G-175	32	2.5	67	-	-	-
9.7d	9.17d	G-177	32	11.0	64	-	-	-
9.7d	9.17d	G-184	32	2.5	67	-	-	-

\* M - Film magazine jam.

**UNCLASSIFIED**

**UNCLASSIFIED**



### Project 1.2

**Purpose:** To determine the time of arrival of the shock front by photographing it against a background of vertical rocket (smoke) trails. To photograph the shock front as it moves along the blast line, showing the path of the triple point and other blast effects phenomenon. To photograph the shock front over the smoke layer.

**Scope:** Quantitative information was requested by this project. Consequently, large frame, high resolution cameras were used in all cases except where higher frame rates were desired.

**Treatment:** Cameras were set a considerable distance from the area being photographed, and, where detail was desired, long focal length lenses were used. This was to avoid the expense and difficulty of constructing camera stations nearer to ground zero. Timing marks were put on all films. The rocket photography was attempted on Shots 1, 4, 9, 10, and 11. The shock front photography was attempted on Shots 9 and 10.

**Comments:** A shock front may be seen only by the effect it produces. That effect which enables one to photograph a shock front in air is the refraction of light passing through the front. This refraction is caused by the greater density of the air at the front than the air around it. Rocket trails, by providing a continuous vertical discontinuity, served to increase the visibility of this effect. Where the shock front is exceedingly strong, it can be photographed without this background, and in fact, the success of the photography was roughly proportional to the yield of the shots. The lenses on some cameras were vignetted by the filters and on one camera the lens was damaged by the thermal, causing the film to become blurred. In general the photography for this project was excellent. Marks caused by the Clayden effect may be noticed on one film.

### Project 3.5

**Purpose:** To observe the modes of failures of various types of roof and wall panels under shock.

**Scope:** Although some measurements were to be made from these films, the analysis was to be primarily qualitative.

**Treatment:** The cameras were installed as shown on the project layout sketches.

**Comments:** Results in general were excellent although there was some

thermal smoke from roof and panel surface or the dust thereon.

#### Project 3.16

**Purpose:** To observe photographically the failure of individual glass panes as well as failure of the window as a whole.

**Scope:** The opening of the window as a whole was to be measured from the film. Otherwise, analysis was to be primarily qualitative.

**Treatment:** This station was somewhat complicated from an electrical standpoint. Eleven kilowatts of incandescent lighting was provided for each window, and a blast switch was used to start the Fastax cameras. A 200 cycle timing marker generator was required to furnish timing marks for the cameras. This required 115 volts AC which was furnished by a battery driven inverter.

**Comments:** The photography for this project was excellent. The timing marks were not recorded on the films because of a power failure.

#### Project 3.19

**Purpose:** To record the particle displacement by the blast wind above the forest stand and to observe the movement of the tree stems caused by the positive and negative phases of the blast wave.

**Scope:** Quantitative results were desired for particle displacement versus time and tree stem displacement versus time measurements. Timing marks were put on all films.

**Treatment:** Large frame cameras giving high resolution were used for this project.

**Comments:** The photographic results were excellent. However, one film showed evidence of the Claydon effect, probably caused by contact of the emulsion with the camera.

#### Project 3.20

**Purpose:** To observe the thermal and blast effects upon a pole line and newly designed microwave towers.

**Scope:** Analysis of the photography was to be qualitative.

**Treatment:** Two cameras were used at this station. One camera covering the end of the pole line and the second camera

**UNCLASSIFIED**

covering the microwave radio relay tower. No back-up cameras were employed on this project so as to obtain greater coverage.

Comments: The photography for this station was excellent and the effects of the thermal and blast were shown in detail.

#### Project 3.21

Purpose: To record gross movement of ordnance equipment by the blast wave.

Scope: Quantitative measurements were desired for stations 3.21e and 3.21k while qualitative data were desired for the remainder of the stations.

Treatment: No stabilization was used at station 3.21e because of its close proximity to ground zero.

Comments: In general, the results were fair; the dust from the blast wave enveloping the targets and the cameras all too quickly. The films of the targets farthest from ground zero were best. Targets in general were too close to the ground.

#### Project 3.22

Purpose: To record movement of a Bailey Bridge by the blast wave.

Scope: It was desired to make displacement versus time measurements from the film.

Treatment: A 25 ft tower was used to bring one pair of cameras up to the level of the bridge. A second 17 ft tower was used to cover the bridge from a different point of view. Primary coverage was provided by A-5 cameras rather than GSAP cameras because timing marks were required.

Comments: The photography for this station was excellent. The 25 ft tower suffered some movement by the shock wave, but not enough to effect the results. The bridge smoked badly from the thermal phase, yet gross movement was quite noticeable.

#### Project 3.24

Purpose: To record movement of a LVT by the blast wave.

Scope: It was desired to make displacement versus time measurements from the film.

**Treatment:** Normal.  
**Comments:** The results of this photography were only fair.

#### Project 3.26.1

**Purpose:** To observe in several types of POL installations when and how fire damage occurs, initial motion and mode of dispersion of POL drums and mode of failure and gross motion of large storage tanks.  
**Scope:** Quantitative information was desired.  
**Treatment:** Normal. Color film was used at distances where radiation was no problem in order to be able to observe ignition and burning of fires.  
**Comments:** The results of this photography were only fair. The targets were too close to the ground and thus generally obscured in dust. The dust problem was worse than expected, partially because of the bombing error in the direction of this project's stations.

#### Project 3.26.2

**Purpose:** To observe mode of ignition of fire in POL installations and mode of dispersion of POL drums by blast.  
**Scope:** Qualitative information only was desired.  
**Treatment:** Normal. Color film was used at distances where radiation was no problem in order to be able to observe ignition and burning of fires.  
**Comments:** The results of this photography were only fair. The targets were too close to the ground and thus generally obscured in dust. The dust problem was worse than expected, partially because of the bombing error in the direction of this project's stations.

#### Project 3.26.3

**Purpose:** To observe the effects of thermal and blast on pliable POL Storage Tanks.  
**Scope:** Analysis of film was to be qualitative only.  
**Treatment:** As this project was an after-thought, the targets were placed on the edge of a stabilized area, using a camera already erected for a Shot 10 target.  
**Comments:** The results of this photography were good and the desired information was recorded on the film.

Project 3.27

**Purpose:** To observe thermal and blast damage to field medical installations.

**Scope:** Analysis of the photography was to be qualitative.

**Treatment:** Normal.

**Comments:** Color film was used at these stations and was not too satisfactory at the closest station because of its poor latitude. The films in general were good and show much detail.

Project 3.29

**Purpose:** To observe the mode of failure of wall panels and in addition the relation times of these failures.

**Scope:** Analysis was to be quantitative, particularly in regard to the time of failure of the different panels.

**Treatment:** The cameras looking at the rear of the building presented a problem inasmuch as these were looking at a shaded object and thus required a faster emulsion than the radiation resistant Type 918. In addition, they were pointed directly toward ground level and thus were in such a position as to receive direct nuclear radiation through the lens opening in the lead shields. To reconcile this latter problem, 45 degree angle mirrors were used.

**Comments:** Photography for this station was good. However, the panels themselves popcorned considerably and much data were obscured by the thermal smoke. The rear panels were almost completely obscured. Care must be exercised when printing from these negatives showing the rear panels since the mirror produced left-right reversal. This was compensated for on the prints originally distributed.

Project 8.1

**Purpose:** To observe the effects of blast and thermal radiation on parked aircraft and aircraft components.

**Scope:** Some displacement versus time measurements were desired. The principal part of the photographic analysis was to be qualitative.

**Treatment:** Cameras were placed extremely close to the objects because of the small disturbances it was desired to observe (wrinkling of the aircraft skin). High speed Eastman cameras in lead shielded boxes were used in this

project. These were mounted vertically and observed their targets by means of a 45 degree angle mirror.

Comments: The results of this photography were excellent showing the desired information in detail. Color was used very successfully at the most distant station. Care must be exercised when printing from the negatives exposed through the 45 degree mirrors since these produced left-right reversal. This was compensated for on the prints originally distributed.

#### Project 8.5

Purpose: To observe the effects of thermal radiation on animals in uniform and, in addition, to observe the effects of blast on any fires which may have been started in the uniforms.

Scope: The analysis of the photography was to be qualitative.

Treatment: Normal. Color film was used at the two most distant stations in order to be able to observe fires in clothing.

Comments: Because of the narrow latitude of the color film, the early thermal phase was almost blanked out. However, the thermal phase just prior to the blast wave showed the desired information. The targets were located too near the ground and were too small, which impaired the photography in general for this project. The results of the photography were only fair.

#### Project 8.11a

Purpose: To record the ignition behavior and duration of any fires started in the test objects.

Scope: Analysis of the photography was to be qualitative and in a sense pictorial.

Treatment: Due to the short running time of the film and the long coverage desired, it was necessary to use time sequence photography on some of these cameras. The time sequence cameras ran for approximately 30 sec, then 5 sec operation out of every 60 sec for approximately 20 min.

Comments: Some photography was excellent, some fair. Color film was used so the effects of fires could be determined, and at the station approximately 8000 ft from ground zero the critical latitude of the color film was not too badly affected by the bomb light. In addition the blast wave knocked out some electrical circuits.

**UNCLASSIFIED**

Project 8.11b

**Purpose:** To record ignition behavior and duration of any fires started around the test objects.

**Scope:** Analysis of the photography was to be qualitative.

**Treatment:** Due to the short running time of the film and the long coverage desired, it was necessary to use time sequence photography on some of these cameras. The time sequence cameras ran for approximately 30 sec, then 5 sec operation out of every 60 sec for approximately 20 min.

**Comments:** The photography at this station was excellent. Color film was used so the effects of the fires could be determined, and as this station was approximately 8000 ft from ground zero the critical latitude of the color film was not too badly affected by the bomb light.

Project 9.1G

**Purpose:** To provide a photographic record of the effects from an atomic blast on various pieces of government issued equipment in a foxhole.

**Scope:** Analysis will be qualitative and pictorial.

**Treatment:** Normal.

**Comments:** In general, the photography was good, although the short transit time between thermal and the arrival of the shock wave precludes detailed prolonged information.

Project 9.7

**Purpose:** To provide evidence of the values of various types of soil stabilization for photographic purposes.

**Scope:** Film analysis will attempt to determine the amount of dust and thermal smoke emanating from each test surface by measuring height of reference markers obscured.

**Treatment:** The cameras were pointed at a reference marker which was set in the middle of the stabilized plot.

**Comments:** In general, the photography was fair, although the short transit time between the thermal and the arrival of the shock wave precludes accurate and prolonged information.

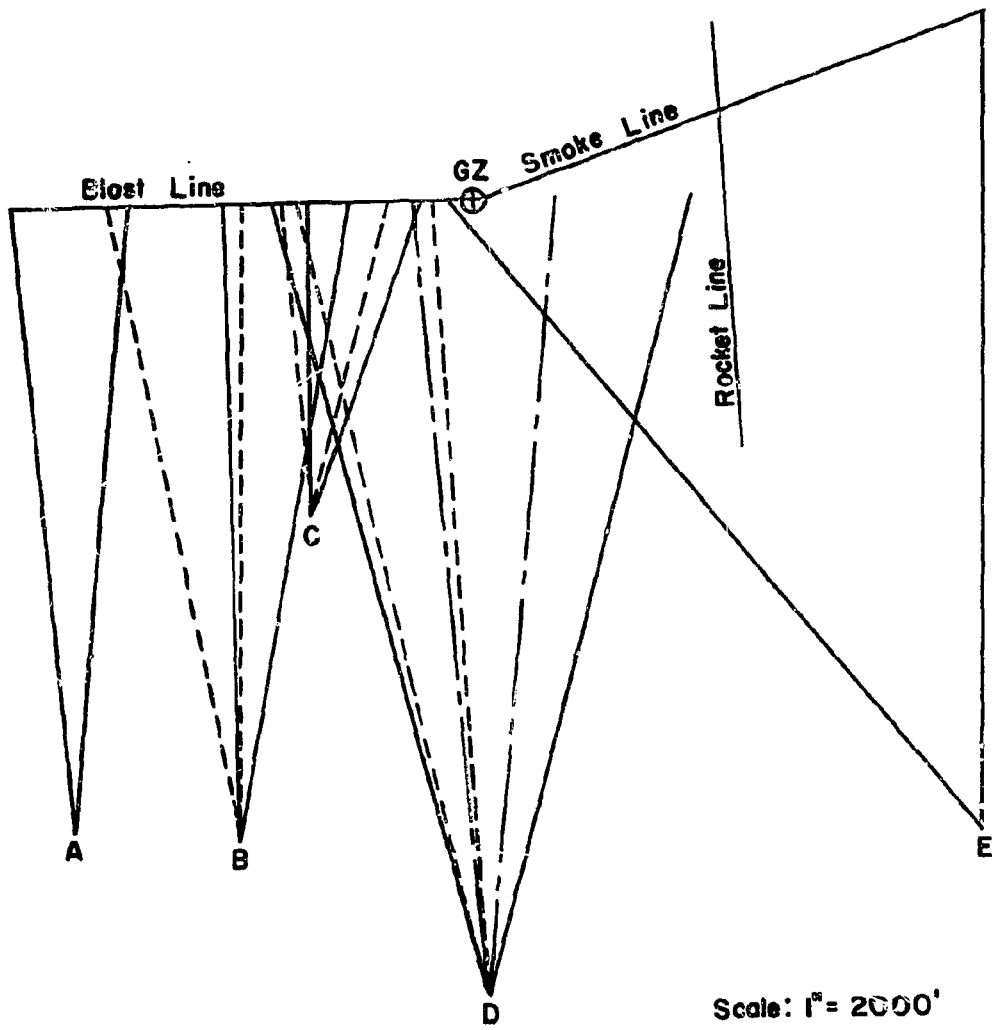

Scale: 1" = 2000'

Project 1.2 (Diagram A)

Camera:	Mitchell	Distance to GZ:	9400'
Fr/Sec:	108	Vertical Angle:	0°
Lens:	152mm	EG&G Station No:	9.1e
Film:	MF	Film Number:	16509
Tower:	Trailer		

Fig. B.1 NOL Blast and Shock Studies

**UNCLASSIFIED**

**CONFIDENTIAL**



Project 1.2 (Diagram B)

Camera:	Mitchell	Distance to GZ:	8500'
Fr/Sec:	100/96	Vertical Angle:	0°
Lens:	152mm/152mm	EG&G Station No:	9.1c
Film:	MF	Film Number:	16506
Tower:	28'		16507

Project 1.2 (Diagram C)

Camera:	Eastman	Distance to GZ:	4600'
Fr/Sec:	537/441	Vertical Angle:	0°
Lens:	102mm/152mm	EG&G Station No:	9.1a
Film:	MF	Film Number:	16501
Tower:	18' 9"		16502

Project 1.2 (Diagram D)

Camera:	Mitchell	Distance to GZ:	10000'
Fr/Sec:	102/98/97	Vertical Angle:	0°
Lens:	152mm/152mm/50mm	EG&G Station No:	9.1b
Film:	MF	Film Number:	16503
Tower:	28'		16504
			16505

Project 1.2 (Diagram E)

Camera:	Mitchell	Distance to GZ:	9200'
Fr/Sec:	103	Vertical Angle:	30.0'
Lens:	35mm	EG&G Station No:	9.1d
Film:	MF	Film Number:	16508
Tower:	28'		

⊕  
GZ

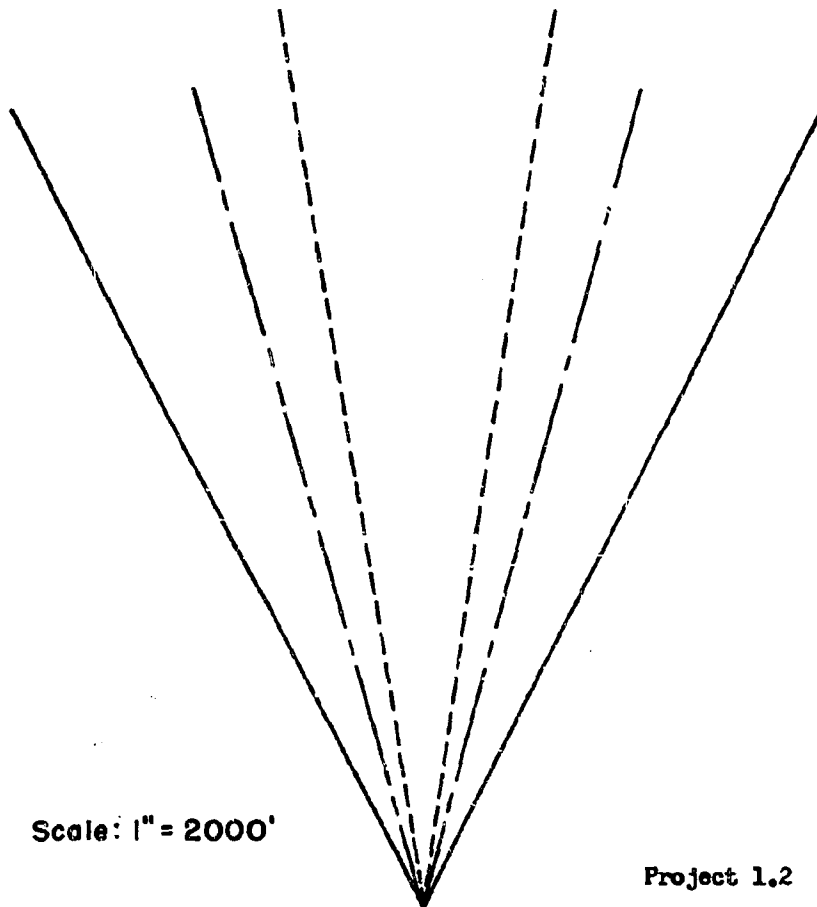

Scale: 1" = 2000'

Project 1.2

<u>Fr/Sec</u>	<u>Lens</u>	<u>Vertical Angle</u>	Camera:	Mitchell
102	25mm	0°	Film:	MF
98	50mm	11.3°	Distance to GZ:	12000'
97	100mm	0°	EG&G Station No:	9.1f
			Film Number:	16510
				16511
				16512

Note: Cameras at this station were mounted in an EG&G photo trailer.

Fig. B.2 NOL Elast and Shock Studies

**UNCLASSIFIED**

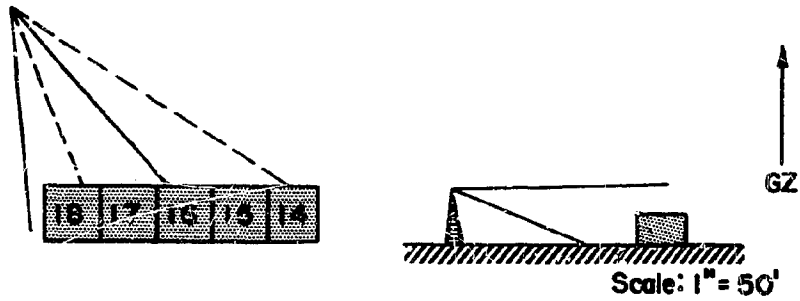

Project 3.5a

Camera: GSAP  
 Fr/Sec: 62  
 Lens: 18mm  
 Film: MF  
 Tower: 18' 9"

Distance to GZ: 6673'  
 Vertical Angle: 12.0°  
 EG&G Station No: 9.21  
 Film Number: 16521  
 16522

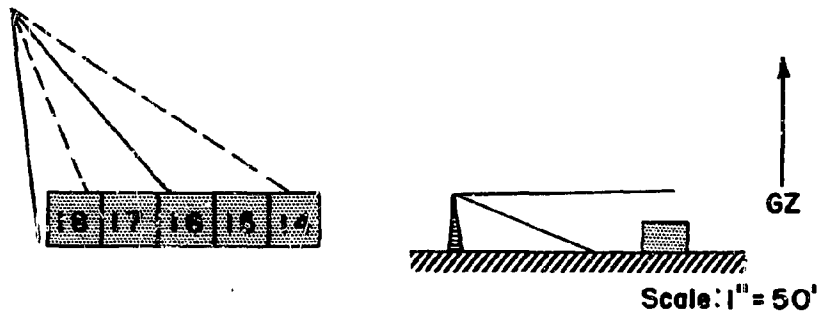

Project 3.5b

Camera: GSAP  
 Fr/Sec: 63  
 Lens: 18mm  
 Film: MF  
 Tower: 18' 9"

Distance to GZ: 4469'  
 Vertical Angle: 7.0°  
 EG&G Station No: 9.2h  
 Film Number: 16519  
 16520

Fig. B.3 USAF Panel Studies

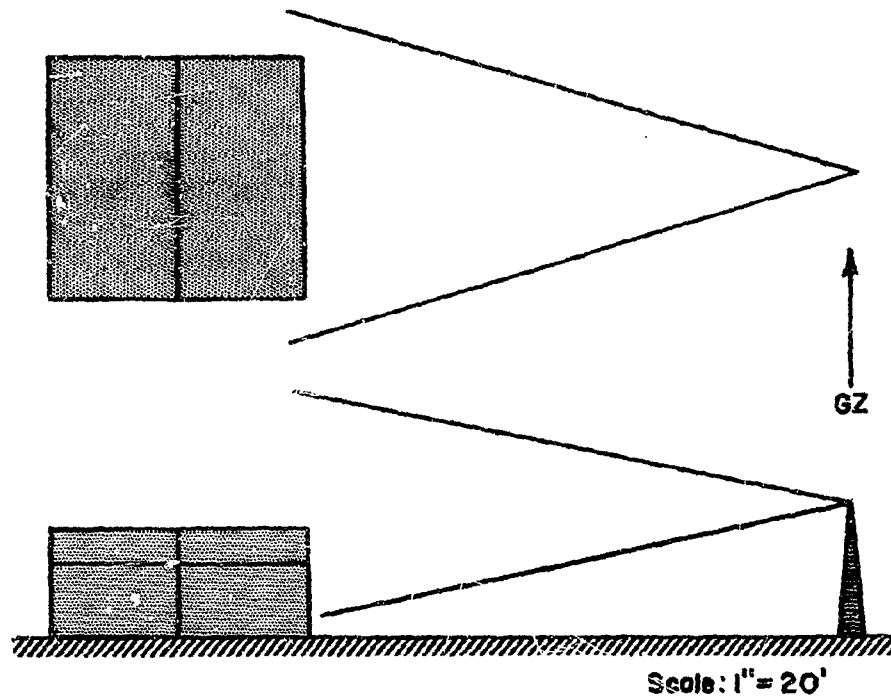

Project 3.5aa

Camera:	GSAP	Distance to GZ:	6686'
Fx/Sec:	65	Vertical Angle:	0°
Lens:	18mm	EG&G Station No:	9.2f
Film:	MF	Film Number:	16517
Tower:	18' 9"		16518

Fig. B.4 USAF Roof Studies

**UNCLASSIFIED**

~~CONFIDENTIAL~~

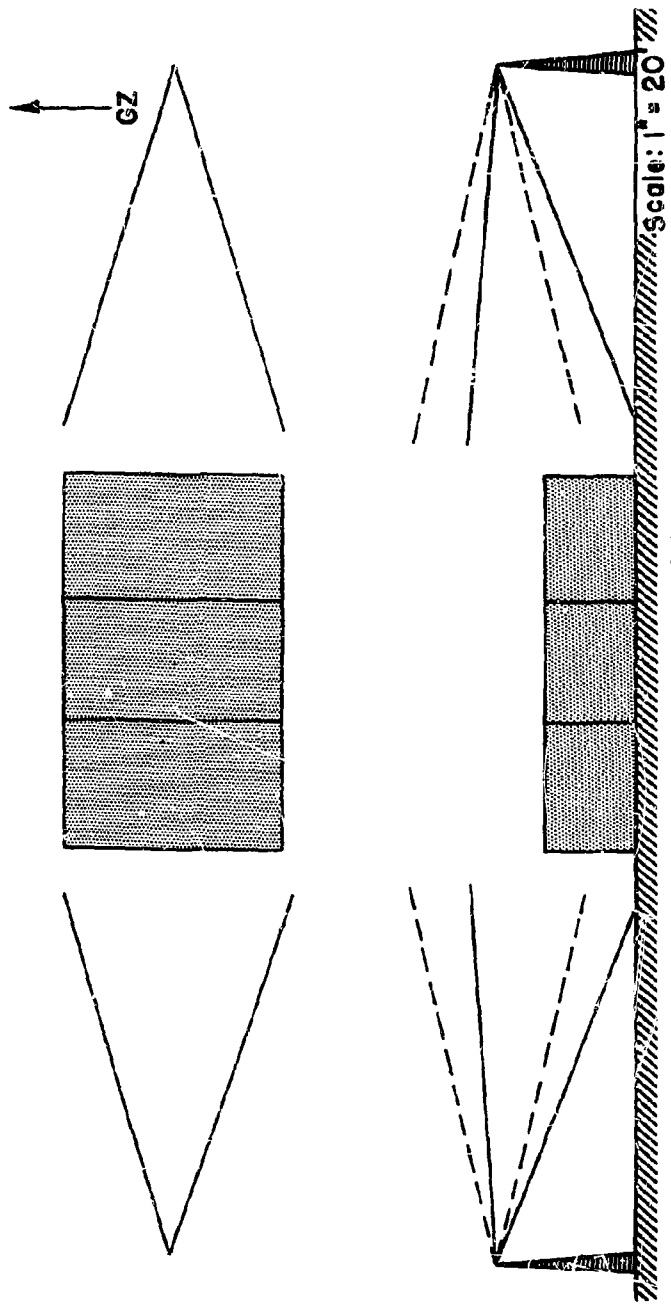

Project 3.5ba & bc

Distance to GZ: 4490'  
 Vertical Angle: 0°-8°  
 T&G Station No: 9.20/c  
 Film Number: 16513, 16514, 16515, 16516

Camera: GSAP  
 Fr/Soc: 64  
 Lens: 18mm MF  
 Tower: 18' 9"

Fig. B.5 USAP Roof Studies

**UNCLASSIFIED**

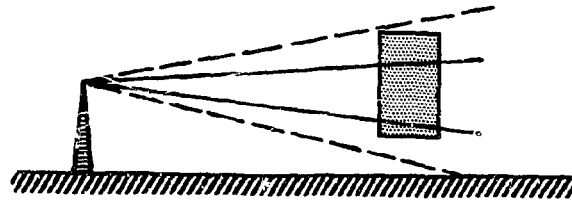
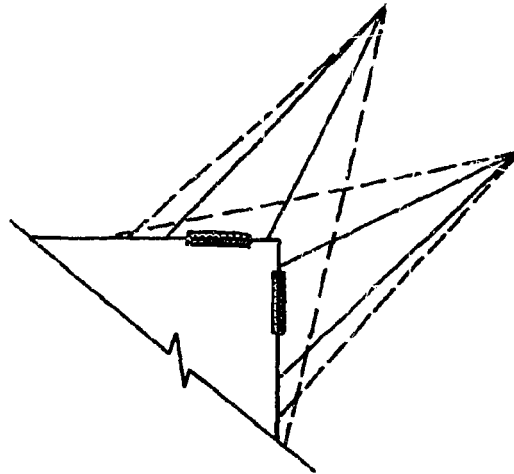

Scale: 1" = 10'

----- GSAP  
 \_\_\_\_\_ Fastax

Project 3.16a

Camera:	GSAP	Fastax	Distance to GZ:	7651'
Fr/Sec:	60	2500	Vertical Angle:	0°
Lens:	18mm	35mm	EG&G Station No:	9.4a/b
Film:	MF	BK	Film Number:	16527
Tower:	6' 3"	6' 3"		16528
				16529
				16530

Fig. B.6 USN Glazing Studies

**UNCLASSIFIED**

~~CONFIDENTIAL~~

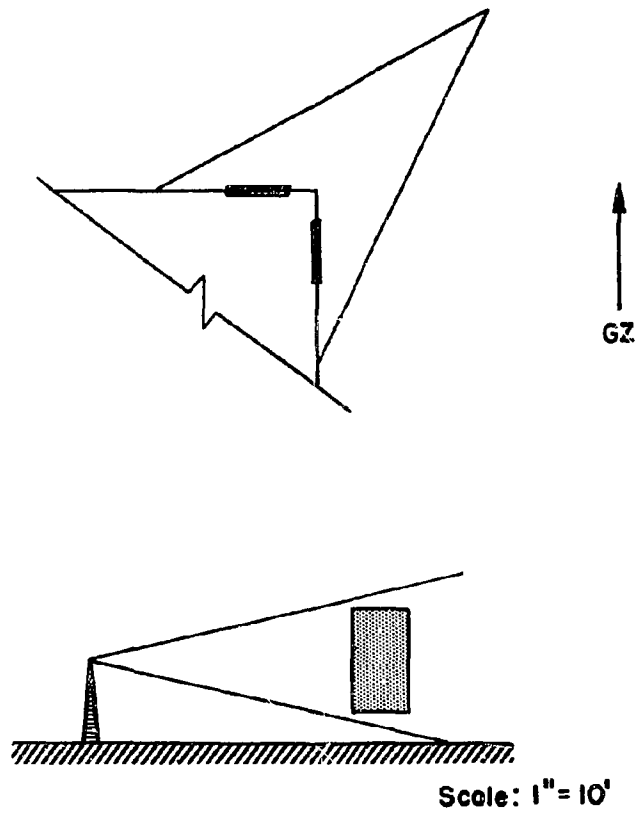

Project 3.16b

Camera:	GSAP	Distance to GZ:	12555'
Fr/Sec:	65	Vertical Angle:	0°
Lens:	18mm	EG&G Station No:	9.4c
Film:	EX	Film Number:	16531
Tower:	6' 3"		16532

Fig. B.7 USN Glazing Studies

**UNCLASSIFIED**

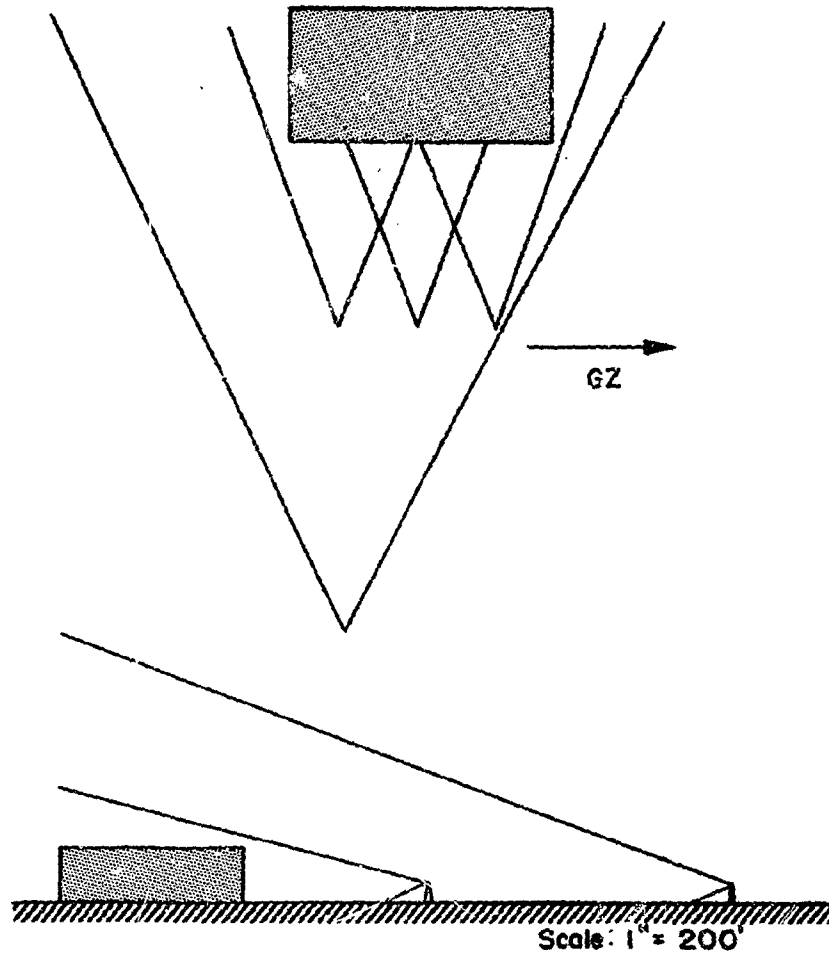

Project 3.19

Camera: Mitchell  
 Fr/Sec: 90  
 Lens: 35mm/25mm  
 Film: MF  
 Tower: 18' 9"

Distance to GZ: 6396'  
 Vertical Angle: 0  
 EC&G Station No: 9.5b-e  
 Film Number: 16533  
 16534  
 16535  
 16536  
 16537

Fig. B.8 AFSWP USFS Forest Studies

**UNCLASSIFIED**

~~CONFIDENTIAL~~



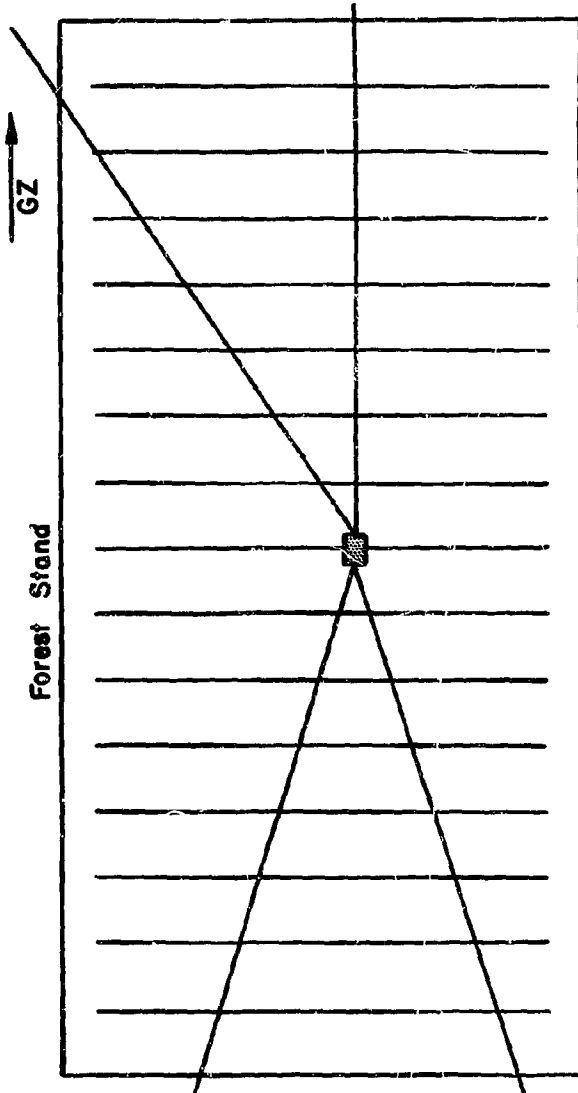

Scale: 1" = 50'

Project 3.19 - Foxhole

Distance to GZ: 6396'  
 Vertical angle: 30.0°  
 EMG Station No: 9.154  
 Film Number: 16681  
 16682

Camera: A-5  
 Fr/Sec: 32  
 Lens: 35mm  
 Film: MF  
 Tower: -1.0'

Fig. B.9 AFSMP Foxhole Studies

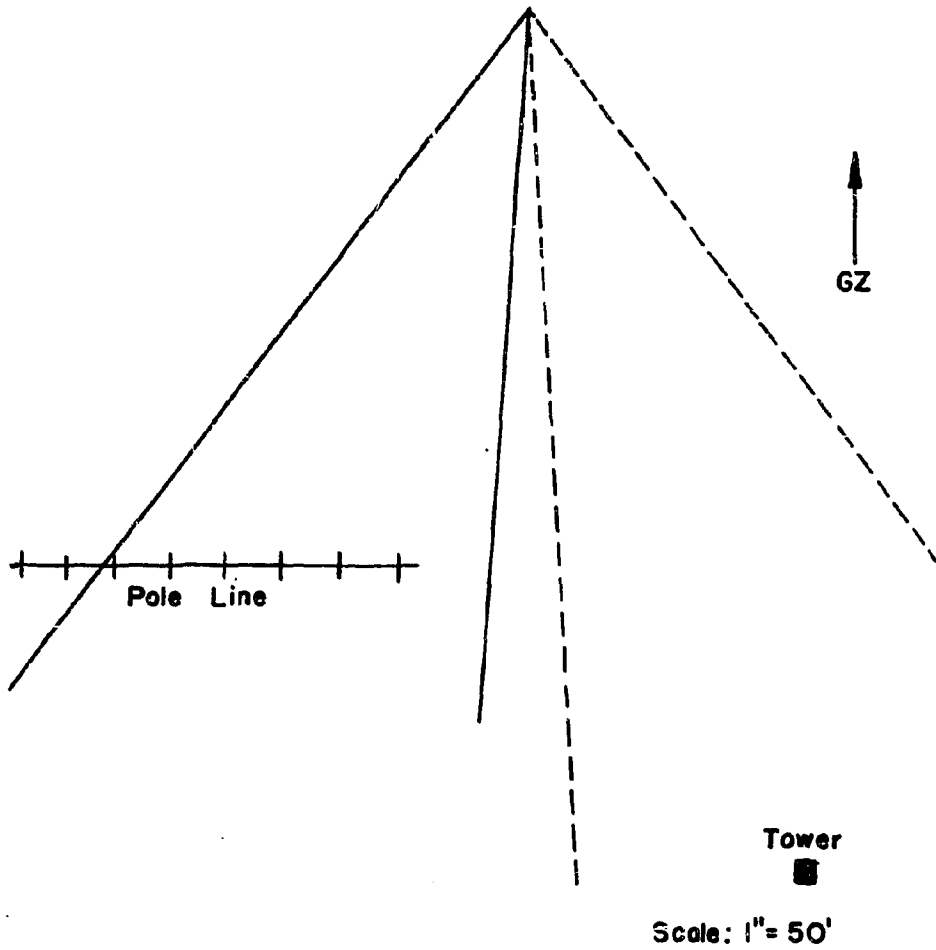

Project 3.20

Camera: GSAP  
 Fr/Sec: 64  
 Lens: 18mm  
 Film: MF  
 Tower: 18' 9"

Distance to GZ: 3239'  
 Vertical Angle: 0°  
 EG&G Station No: 9.3d  
 Film Number: 16523  
 16524

Fig. B.10 U. S. Army Signal Corps Studies

**UNCLASSIFIED**

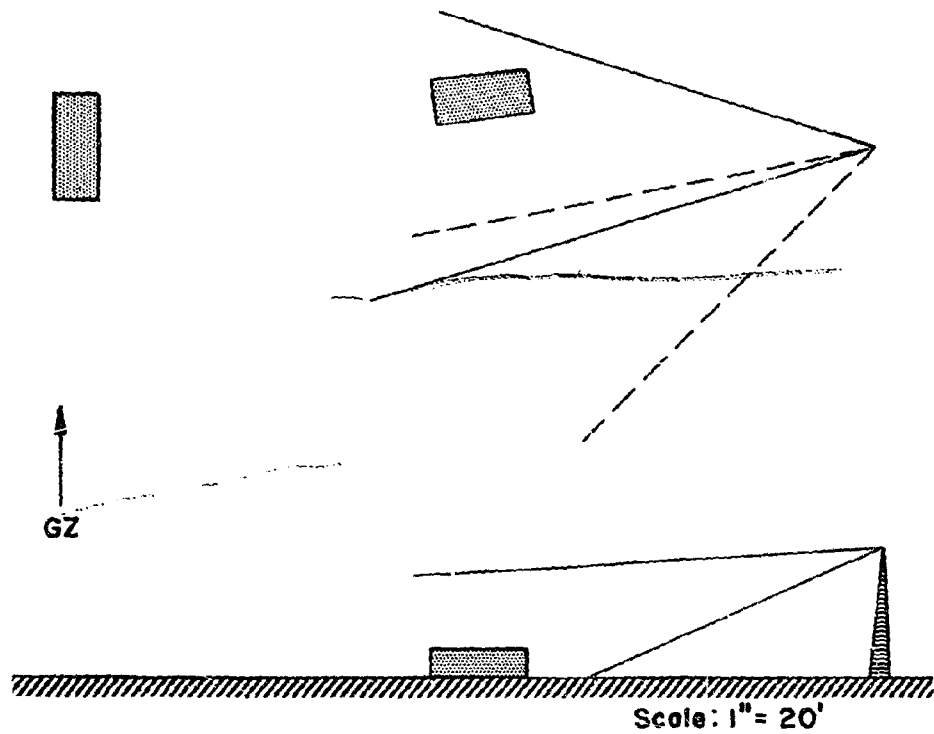

Project 3.21e

Camera:	GSAP	Distance to GZ:	1640'
Fr/Sec:	63	Vertical Angle:	-10.5°
Lens:	18mm	EG&G Station No:	9.6a
Film:	MF	Film Number:	16538
Tower:	18' 9"		16539

Project 3.211

Camera:	GSAP	Distance to GZ:	2174'
Fr/Sec:	63	Vertical Angle:	-9.0°
Lens:	18mm	EG&G Station No:	9.6b
Film:	MF	Film Number:	16540
Tower:	18' 9"		16541

Fig. B.11 BRL: Vehicle Studies

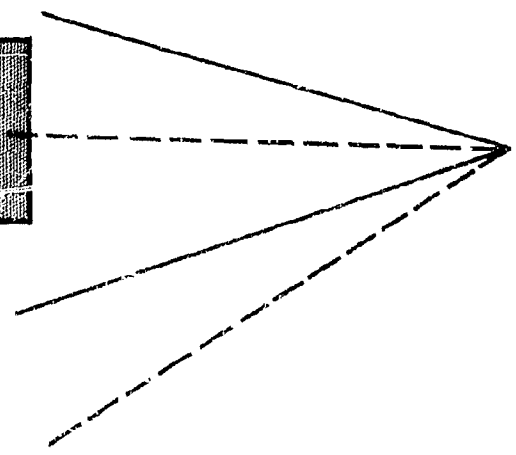
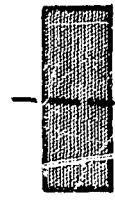

Scale: 1" = 20'

Project 3.21k

Camera: GSAP  
 Fr/Sec: 64  
 Lens: 18mm  
 Film: MF  
 Tower: 11' 3"

Distance to GZ: 4945'  
 Vertical Angle: 0°  
 EGG Station No: 9.6c  
 Film Number: 16542  
 16543

Project 3.21m

Camera: GSAP  
 Fr/Sec: 64  
 Lens: 18mm  
 Film: MF  
 Tower: 11' 3"

Distance to GZ: 6927'  
 Vertical Angle: -2.0°  
 EGG Station No: 9.6d  
 Film Number: 16544  
 16545

Fig. B.12 ERL Vehicle Studies

**UNCLASSIFIED**

~~CONFIDENTIAL~~

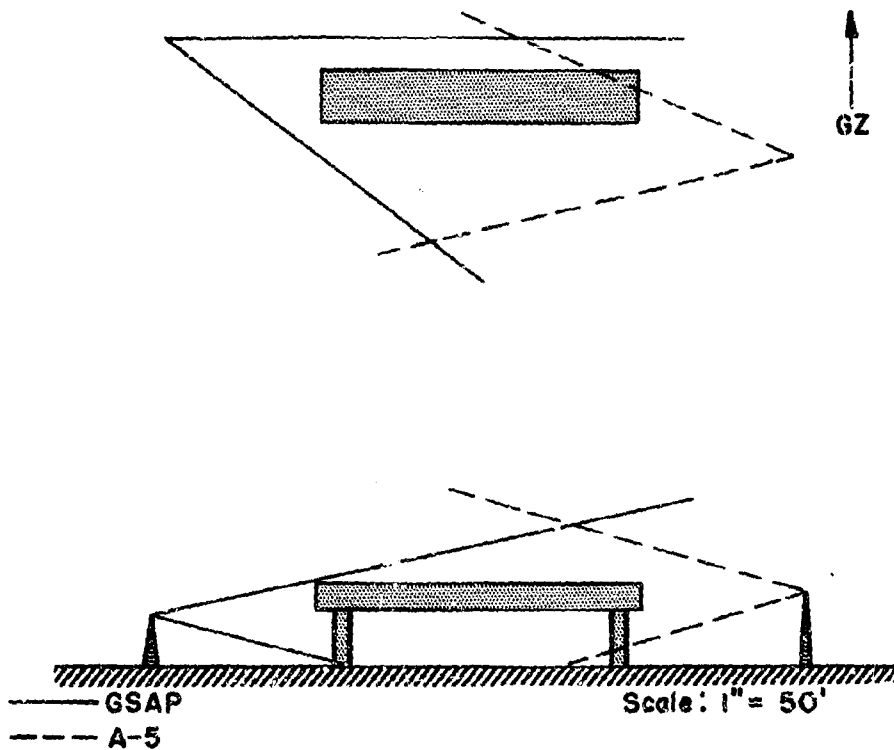

Project 3.22b

Camera:	GSAP	A-5	Distance to GZ:	4214'
Fr/Sec:	33	24	Vertical Angle:	0°
Lens:	18mm	35mm	EG&G Station No:	9.7a/b
Film:	MF	MF	Film Number:	16546
Tower:	18' 9"	28'		16547
				16548
				16549

Fig. B.13 Corps of Engineers Bailey Bridge Studies

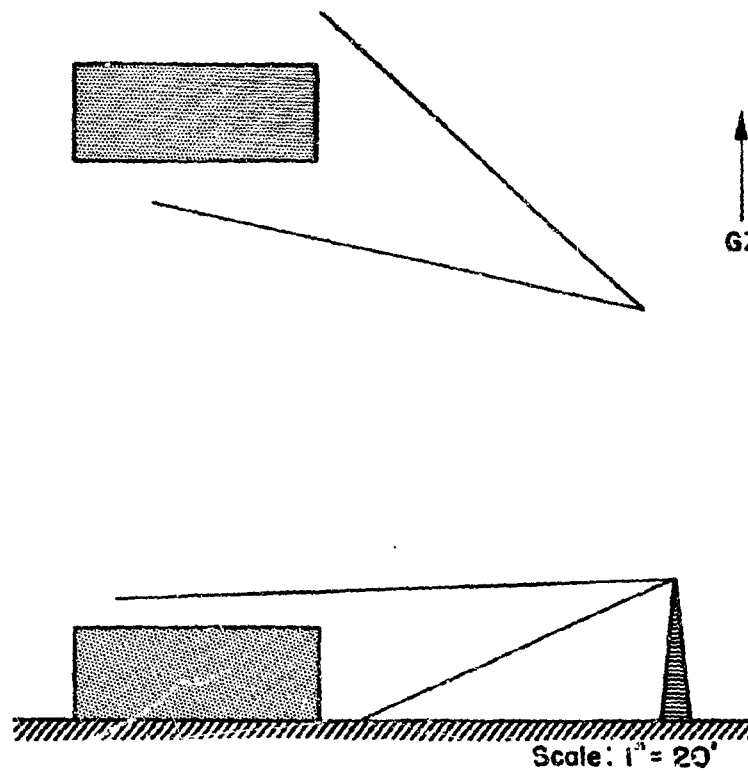

Project 3.24d

Camera:	GSAP	Distance to GZ:	2440'
Fr/Sec:	65	Vertical Angle:	-16.5°
Lens:	18mm	EG&G Station No:	9.15c
Film:	MF	Film Number:	16679
Tower:	18' 9"		16680

Fig. B.14 AFSWP - U. S. Navy LVT Studies

**UNCLASSIFIED**

**CONFIDENTIAL**

Camera: GSAP  
 Fr/Sec: 64  
 L/Ans: 40mm/18mm

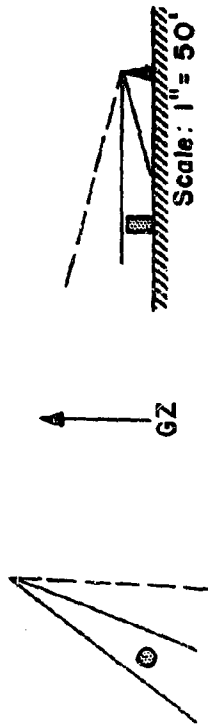

Project	Film	Tower	Distance to GZ	Vertical Angle	ESAG Sta No	Film No
3.26.1aa	KC	11' 13"	4676'	-7°/-5°	9.8h	16564 16565
3.26.1ac	MF	18' 9"	2400'	-19°/-13°	9.8e	16558 16559
3.26.1af	MF	18' 9"	1246'	-17°/-12°	9.8b	16552 16553
3.26.1aj	KC	11' 3"	4615'	-8°/-5°	9.8i	16566 16567
3.26.1al	MF	18' 9"	2334'	-19°/-13°	9.8f	16560 16561
3.26.1am	MF	18' 9"	1318'	-17°/-12°	9.8a	16550 16551

Fig. B.15 USAF POL Stud. 98

UNCLASSIFIED

**UNCLASSIFIED**

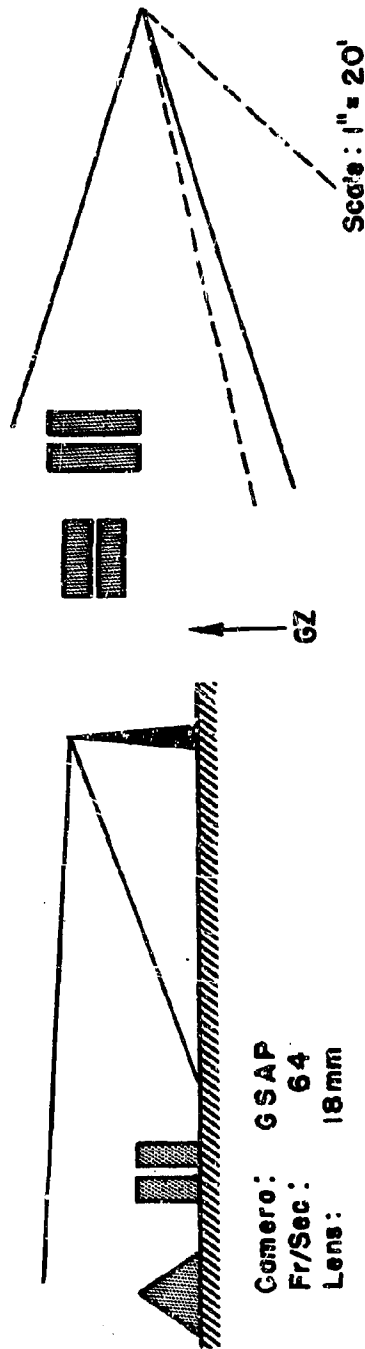

Project	Film	Tower	Distance to GZ	Vertical Angle	EC&G Sta No	Film No
3.26.1au	MF	18' 9"	4580'	-7.0°	9.8j	16568 16569
3.26.1ay	MF	18' 9"	4600'	-7.0°	9.8k	16570 16571
3.26.1az	MF	18' 9"	1660'	-11.0°	9.8l	16536 16537
3.26.1ax	MF	18' 9"	3405'	-16.0°	9.8g	16562 16563
3.26.1ass	MF	18' 9"	1104'	-14.0°	9.8o	16534 16535

Fig. B.16 USAF POL Studies

**CONFIDENTIAL**



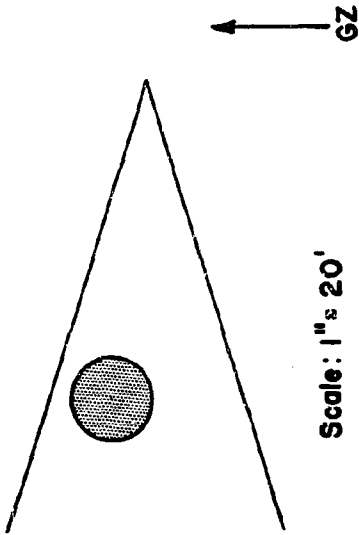

Camera: GSAP  
 Ft/Sac: 64  
 Lens: 18 mm

Project	File	Tower	Distance to GZ	Vertical Angle	EDG Sta No	Film No
3.26.1bb	BK	18' 9"	9260'	-19.0°	9.8n	16576 16577
3.26.1bc	BK	18' 9"	9242'	-19.0°	9.8o	16578 16579
3.26.1be	MF	18' 9"	3602'	-19.0°	9.8l	16572 16573
3.26.1bd	MF	18' 9"	6851'	-19.0°	9.8m	16574 16575

Fig. B.17 USAF POL Studies

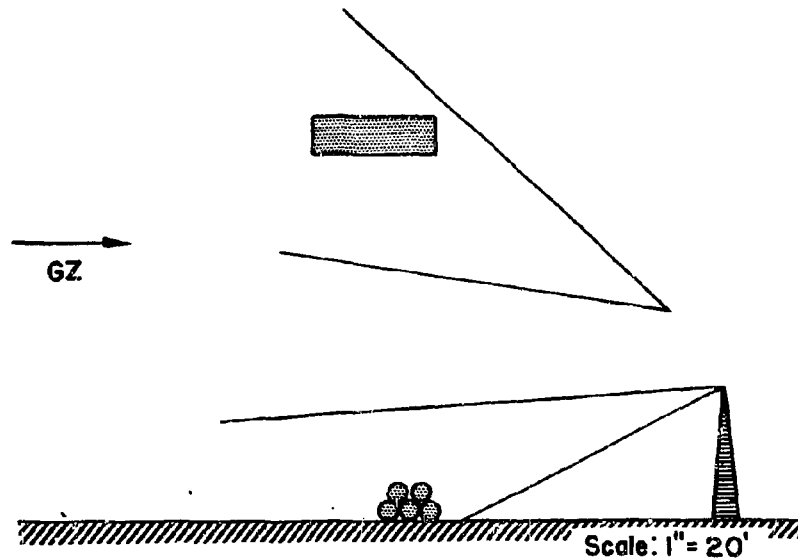

Project 3.26.2da-2

Camera:	GSAP	Distance to GZ:	2467'
F <sub>r</sub> /Sec:	32	Vertical Angle:	-22.0°
Lens:	18mm	EG&G Station No:	9.9a
Film:	NF	Film Number:	16580
Tower:	18' 9"		16581

Project 3.26.2db-2

Camera:	GSAP	Distance to GZ:	4056'
F <sub>r</sub> /Sec:	32	Vertical Angle:	-22.0°
Lens:	18mm	EG&G Station No:	9.9e
Film:	KC	Film Number:	16588
Tower:	18' 9"		16589

Project 3.26.2dc-2

Camera:	GSAP	Distance to GZ:	6735'
F <sub>r</sub> /Sec:	32	Vertical Angle:	-22.0°
Lens:	18mm	EG&G Station No:	9.9i
Film:	KC	Film Number:	16596
Tower:	18' 9"		16597

Fig. B.16 U. S. Army QMC POL Studies

**UNCLASSIFIED**

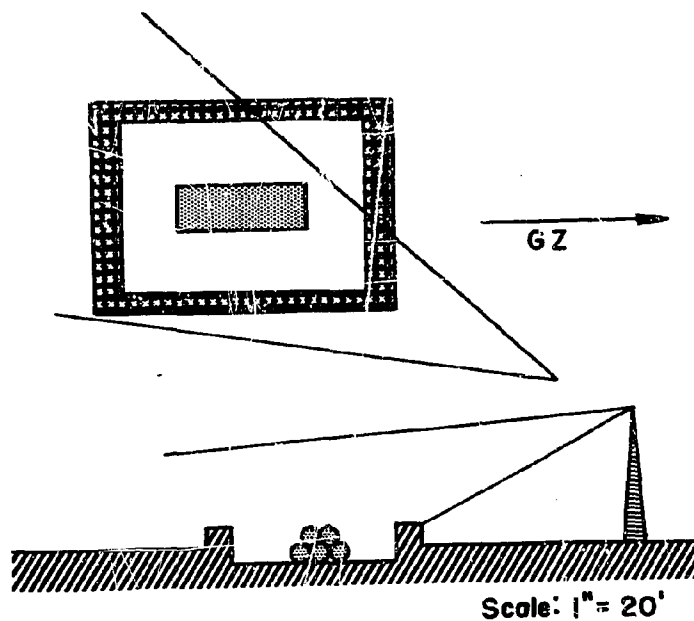

Project 3.26.2da-3

Camera:	GSAP	Distance to GZ:	2488'
Fr/Sec:	32	Vertical Angle:	-23.0°
Lens:	18mm	EG&G Station No:	9.9b
Film:	MF	Film Number:	16582
Tower:	18' 9"		16583

Project 3.26.2db-3

Camera:	GSAP	Distance to GZ:	4071'
Fr/Sec:	32	Vertical Angle:	-23.0°
Lens:	18mm	EG&G Station No:	9.9f
Film:	MF	Film Number:	16590
Tower:	18' 9"		16591

Project 3.26.2dc-3

Camera:	GSAP	Distance to GZ:	6746'
Fr/Sec:	32	Vertical Angle:	-23.0°
Lens:	18mm	EG&G Station No:	9.9j
Film:	MF	Film Number:	16598
Tower:	18' 9"		16599

Fig. B.19 U. S. Army (MC POL Studies

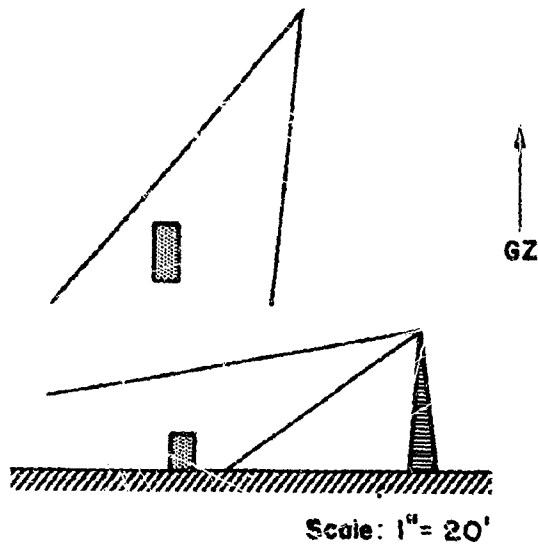

Project 3.26.2da-7

Camera:	GSAP	Distance to GZ:	2447'
F <sub>r</sub> /Sec:	32	Vertical Angle:	-23.0°
Lens:	18mm	EG&G Station No:	9.9c
Film:	MF	Film Number:	16584
Tower:	18' 9"		16585

Project 3.26.2db-7

Camera:	GSAP	Distance to GZ:	4040'
F <sub>r</sub> /Sec:	32	Vertical Angle:	-22.5°
Lens:	18mm	EG&G Station No:	9.9g
Film:	MF	Film Number:	16592
Tower:	18' 9"		16593

Project 3.26.2dc-7

Camera:	GSAP	Distance to GZ:	6725'
F <sub>r</sub> /Sec:	32	Vertical Angle:	-22.5°
Lens:	18mm	EG&G Station No:	9.9k
Film:	MF	Film Number:	16600
Tower:	18' 9"		16601

Fig. B.20 U. S. Army QMC POL Studies

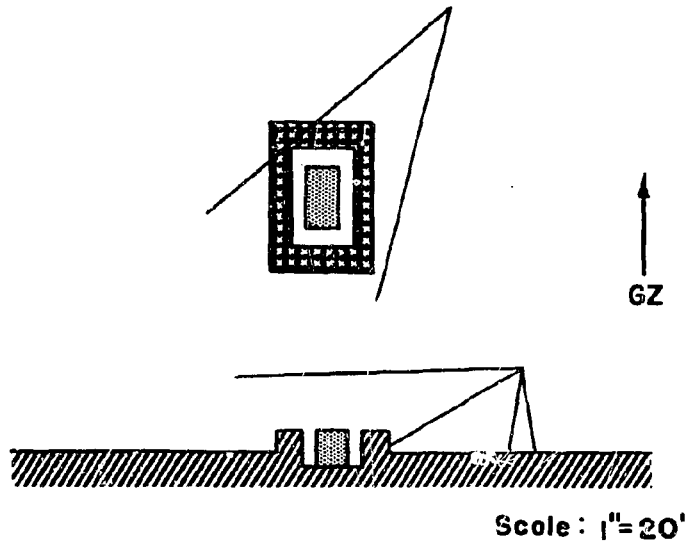

Project 3.26.2da-9

Camera:	GSAP	Distance to GZ:	2510'
Fr/Sec:	32	Vertical Angle:	-21.0°
Lens:	18mm	EG&G Station No:	9.9d
Film:	MF	Film Number:	16586
Tower:	11' 3"		16587

Project 3.26.2db-9

Camera:	GSAP	Distance to GZ:	6756'
Fr/Sec:	32	Vertical Angle:	-16.5°
Lens:	18mm	EG&G Station No:	9.9h
Film:	MF	Film Number:	16602
Tower:	11' 3"		16603

Project 3.26.2dc-9

Camera:	GSAP	Distance to GZ:	4087'
Fr/Sec:	32	Vertical Angle:	-22.5°
Lens:	18mm	EG&G Station No:	9.9i
Film:	MF	Film Number:	16594
Tower:	11' 3"		16595

Fig. B.21 U. S. Army QMC POL Studies

~~CONFIDENTIAL~~  
UNCLASSIFIED

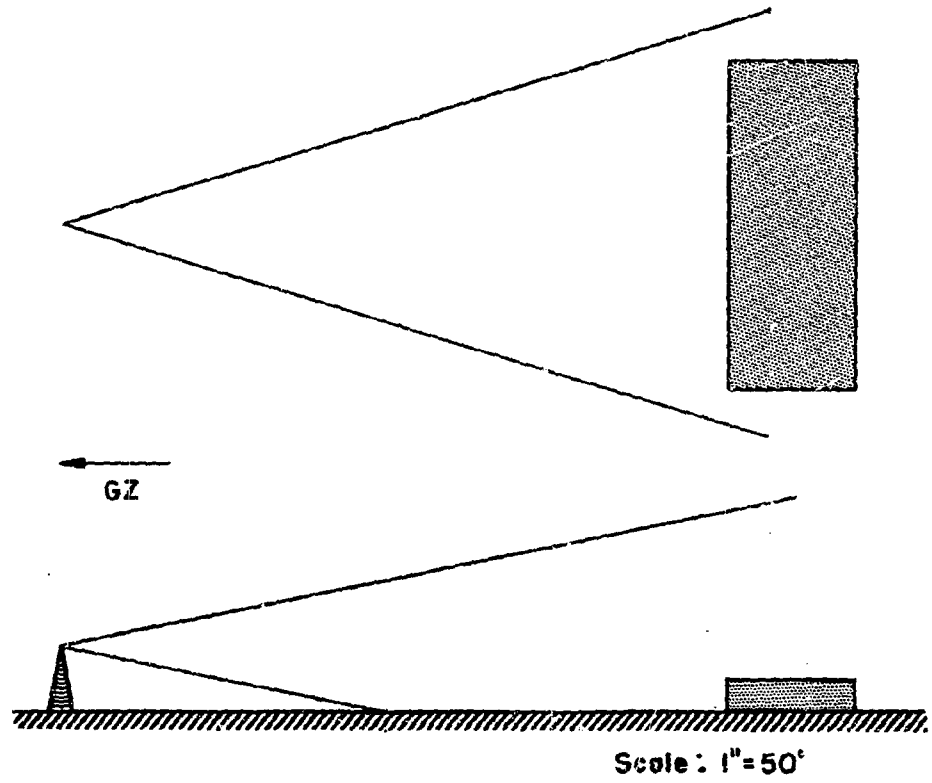

Project 3.26.3

Camera:	GSAP	Distance to GZ:	3740'
Fr/Sec:	64	Vertical Angle:	0°
Lens:	18mm	EG&G Station No:	9.31
Film:	MF	Film Number:	16525
Tower:	18' 9"		16526

Fig. B.22 USMC POL Studies

**UNCLASSIFIED**

~~CONFIDENTIAL~~  
**UNCLASSIFIED**

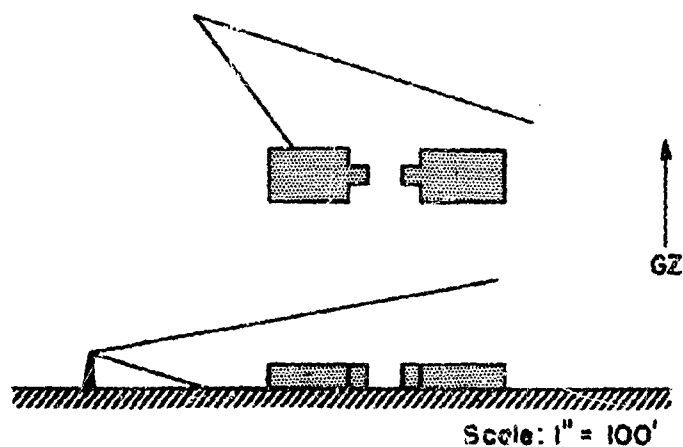

Project 3.27a

Camera:	GSAP	Distance to GZ:	4300'
Fx/Sec:	67	Vertical Angle:	-2.0°
Lens:	18mm	EG&G Station No:	9.16a
Film:	KC	Film Number:	16683
Tower:	18' 9"		16684

Project 3.27b

Camera:	GSAP	Distance to GZ:	9092'
Fx/Sec:	62	Vertical Angle:	-2.0°
Lens:	18mm	EG&G Station No:	9.16b
Film:	KC	Film Number:	16685
Tower:	18' 9"		16686

Project 3.27c

Camera:	GSAP	Distance to GZ:	15105'
Fx/Sec:	65	Vertical Angle:	-2.0°
Lens:	18mm	EG&G Station No:	9.16c
Film:	KC	Film Number:	16687
Tower:	18' 9"		16688

Fig. B.23 U. S. Army Medical Corps Hospital Studies

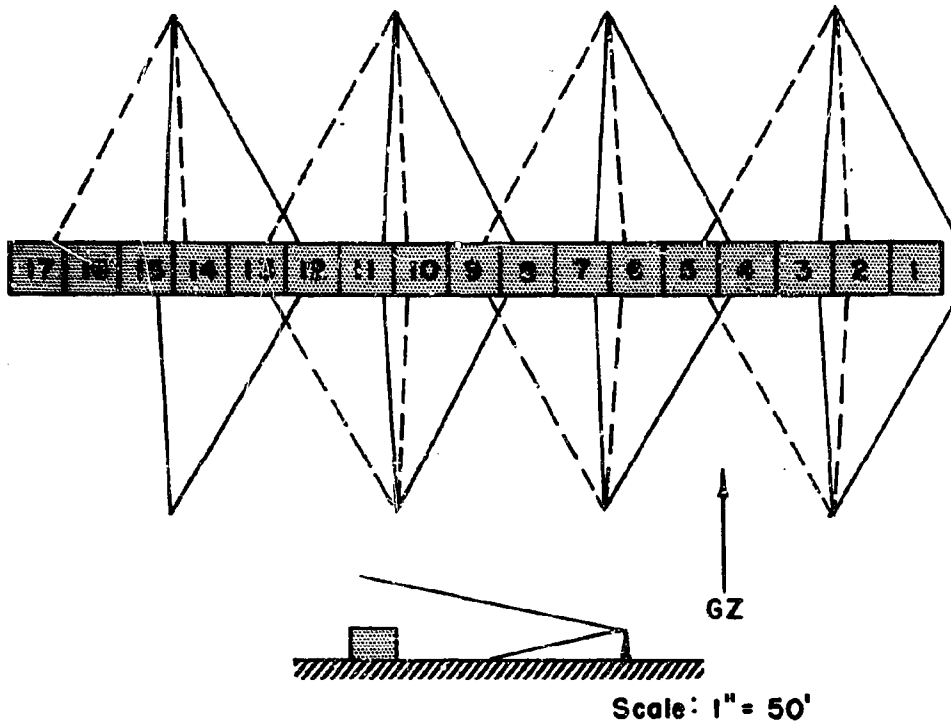

Project 3.29a (Front Panels 1-4)

Camera:	GSAP	Distance to GZ:	6642'
Fr/Sec:	65	Vertical Angle:	0°
Lens:	18mm	EG&G Station No:	9.10k
Film:	MF	Film Number:	16624
Tower:	11' 3"		16625

Fig. B.24. CETG Panel Studies

**UNCLASSIFIED**

~~CONFIDENTIAL~~



Project 3.29a (Front Panels 5-8)

Camera:	GSAP	Distance to GZ:	6649'
Fr/Sec:	61	Vertical Angle:	0°
Lens:	18mm	EG&G Station No:	9.101
Film:	MF	Film Number:	16626
Tower:	11' 3"		16627

Project 3.29a (Front Panels 9-12)

Camera:	GSAP	Distance to GZ:	6657'
Fr/Sec:	60	Vertical Angle:	0°
Lens:	18mm	EG&G Station No:	9.10m
Film:	MF	Film Number:	16628
Tower:	11' 3"		16629

Project 3.29a (Front Panels 13-16)

Camera:	GSAP	Distance to GZ:	6660'
Fr/Sec:	60	Vertical Angle:	0°
Lens:	18mm	EG&G Station No:	9.10m
Film:	MF	Film Number:	16630
Tower:	11' 3"		16631

Project 3.29a (Rear Panels 1-4)

Camera:	GSAP	Distance to GZ:	6642'
Fr/Sec:	68	Vertical Angle:	0°
Lens:	18mm	EG&G Station No:	9.10m
Film:	MF	Film Number:	16632
Tower:	11' 3"		16633

Project 3.29a (Rear Panels 5-8)

Camera:	GSAP	Distance to GZ:	6649'
Fr/Sec:	63	Vertical Angle:	0°
Lens:	18mm	EG&G Station No:	9.10p
Film:	MF	Film Numbers:	16634
Tower:	11' 3"		16635

Project 3.29a (Rear Panels 9-12)

Camera:	GSAP	Distance to GZ:	6657'
Fr/Sec:	63	Vertical Angle:	0°
Lens:	18mm	EG&G Station No:	9.10q
Film:	MF	Film Number:	16636
Tower:	11' 3"		16637

Project 3.29a (Rear Panels 13-16)

Camera:	GSAP	Distance to GZ:	6667'
Fr/Sec:	65	Vertical Angle:	0°
Lens:	18mm	EG&G Station No:	9.10r
Film:	MF	Film Number:	16638
Tower:	11' 3"		

**UNCLASSIFIED**

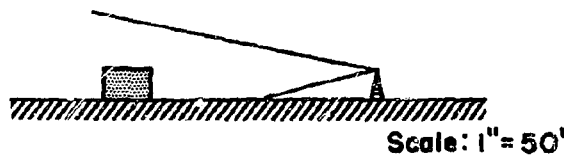
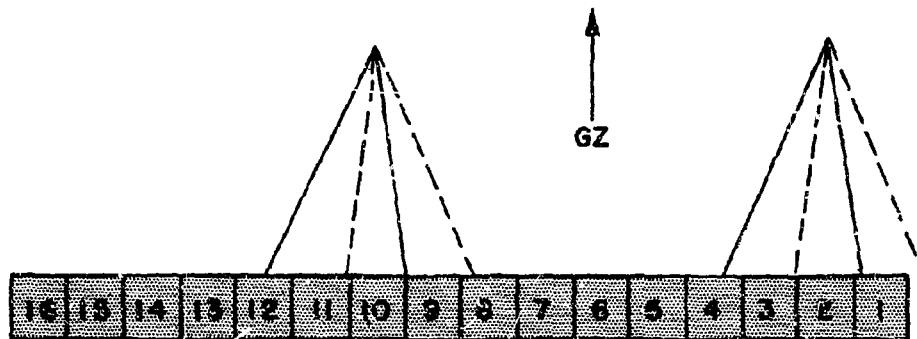

Project 3.29b (Panels 1-3)

Camera:	GSAP	Distance to GZ:	6590'
Fr/Sec:	61	Vertical Angle:	0°
Lens:	18mm	EG&G Station No:	9.10s
Film:	MF	Film Number:	16640
Tower:	11' 3"		16641

Project 3.29b (Panels 9-11)

Camera:	GSAP	Distance to GZ:	6604'
Fr/Sec:	63	Vertical Angle:	0°
Lens:	18mm	EG&G Station No:	9.10t
Film:	MF	Film Number:	16642
Tower:	11' 3"		16643

Fig. B.25 CETG Panel Studies

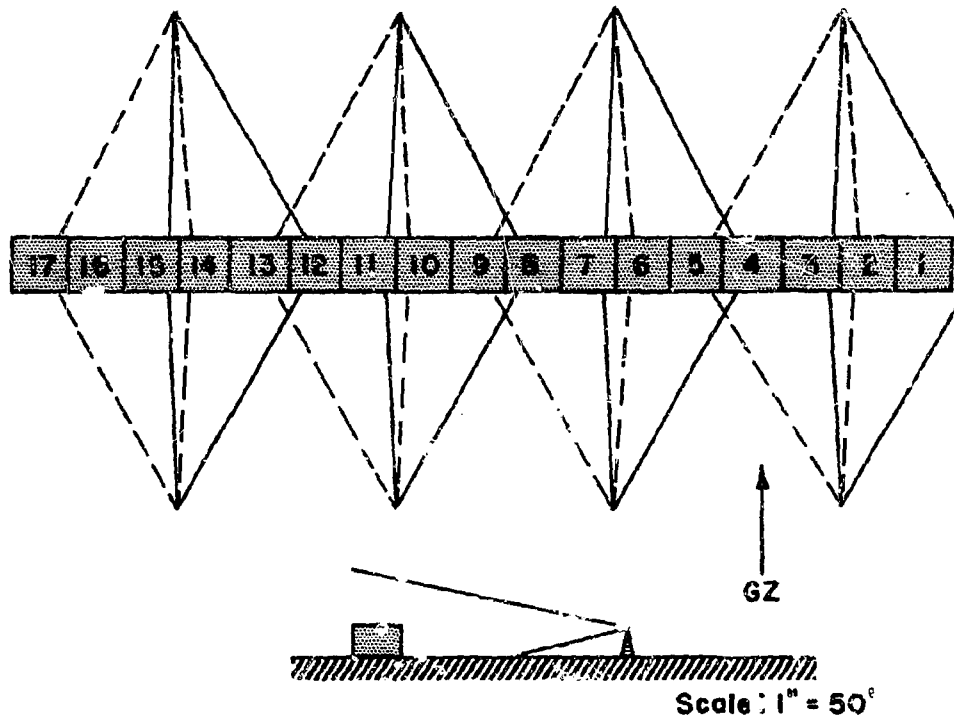

Project 3.29c (Front Panels 1-4)

Camera:	GSAP	Distance to GZ:	1423'
Fr/Sec:	61	Vertical Angle:	0°
Lens:	18mm	EG&G Station No:	9.10a
Film:	MF	Film Number:	16604
Tower:	11' 3"		16505

Fig. B.26 GETG Panel Studies

**UNCLASSIFIED**  
**UNCLASSIFIED**

Project 3.29c (Front Panels 5-8)

Camera:	GSAP	Distance to GZ:	4434'
Fr/Sec:	61	Vertical Angle:	0°
Lens:	18mm	EG&G Station No:	9.10b
Film:	MF	Film Number:	16606
Tower:	11' 3"		16607

Project 3.29c (Front Panels 9-12)

Camera:	GSAP	Distance to GZ:	4446'
Fr/Sec:	62	Vertical Angle:	0°
Lens:	18mm	EG&G Station No:	9.10c
Film:	MF	Film Number:	16608
Tower:	11' 3"		16609

Project 3.29c (Front Panels 13-16)

Camera:	GSAP	Distance to GZ:	4460'
Fr/Sec:	59	Vertical Angle:	0°
Lens:	18mm	EG&G Station No:	9.10d
Film:	MF	Film Number:	16610
Tower:	11' 3"		16611

Project 3.29c (Rear Panels 1-4)

Camera:	GSAP	Distance to GZ:	4423'
Fr/Sec:	66	Vertical Angle:	0°
Lens:	18mm	EG&G Station No:	9.10e
Film:	MF	Film Number:	16612
Tower:	11' 3"		16613

UNCLASSIFIED

85

UNCLASSIFIED

Project 3.29c (Rear Panels 5-8)

Camera:	GSAP	Distance to GZ:	4434'
Fr/Sec:	65	Vertical Angle:	0°
Lens:	18mm	EG&G Station No:	9.10f
Film:	MF	Film Number:	16614
Tower:	11' 3"		16615

Project 3.29c (Rear Panels 9-12)

Camera:	GSAP	Distance to GZ:	4446'
Fr/Sec:	60	Vertical Angle:	0°
Lens:	18mm	EG&G Station No:	9.10g
Film:	MF	Film Number:	16616
Tower:	11' 3"		16617

Project 3.29c (Rear Panels 13-16)

Camera:	GSAP	Distance to GZ:	4460'
Fr/Sec:	64	Vertical Angle:	0°
Lens:	18mm	EG&G Station No:	9.10h
Film:	MF	Film Number:	16618
Tower:	11' 3"		16619

UNCLASSIFIED

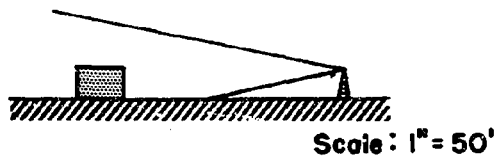
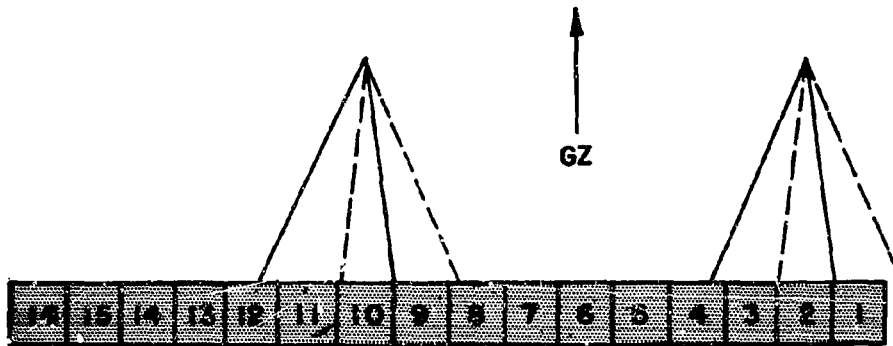

Project 3.29d (Panels 1-3)

Camera:	GSAP	Distance to GZ:	4345'
Fr/Sec:	63	Vertical Angle:	0°
Lens:	18mm	EG&G Station No:	9.10j
Film:	MF	Film Number:	16622
Tower:	11' 3"		16623

Project 3.29d (Panels 9-11)

Camera:	GSAP	Distance to GZ:	4360'
Fr/Sec:	64	Vertical Angle:	0°
Lens:	18mm	EG&G Station No:	9.10i
Film:	MF	Film Number:	16620
Tower:	11' 3"		16621

Fig. B.27 GETG Panel Studies

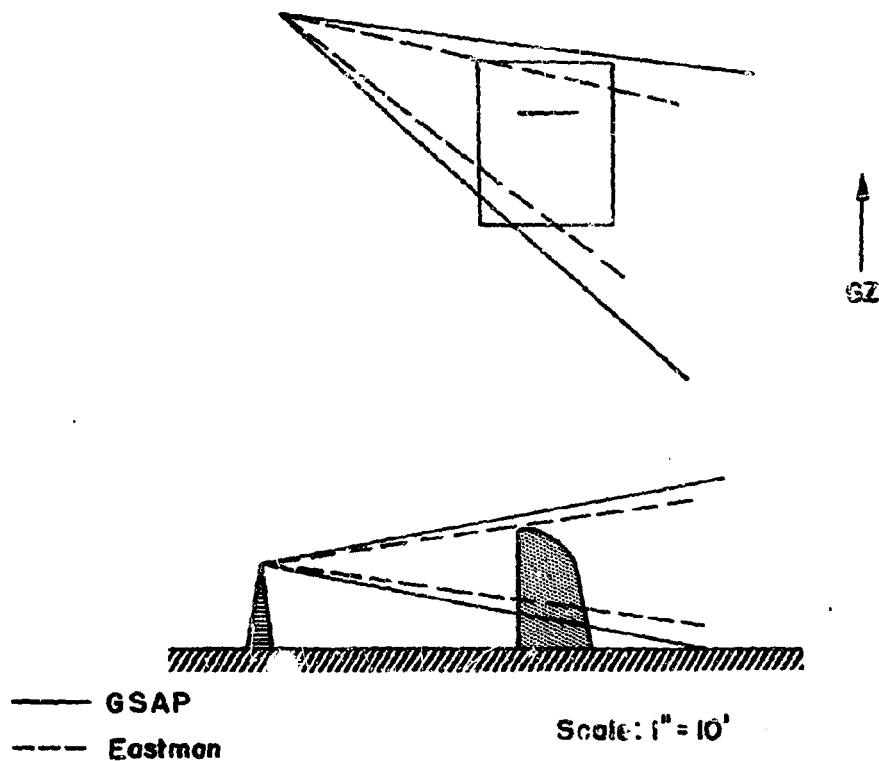

Project 8.1B-1

Camera:	GSAP	Eastman	Distance to GZ:	7106'
F <sub>r</sub> /Sec:	64	606	Vertical Angle:	0°/0°
Lens:	18mm	25mm	EG&G Station No:	9.11f
Film:	KC	BK	Film Number:	16651
Tower:	6' 3"	6' 3"		16652

Project 8.1B-3

Camera:	GSAP	Eastman	Distance to GZ:	7099'
F <sub>r</sub> /Sec:	62	563	Vertical Angle:	0°/0°
Lens:	18mm	25mm	EG&G Station No:	9.11h
Film:	KC	BK	Film Number:	16655
Tower:	6' 3"	6' 3"		16656

Fig. B.28 USAF Aircraft Component Studies

UNCLASSIFIED



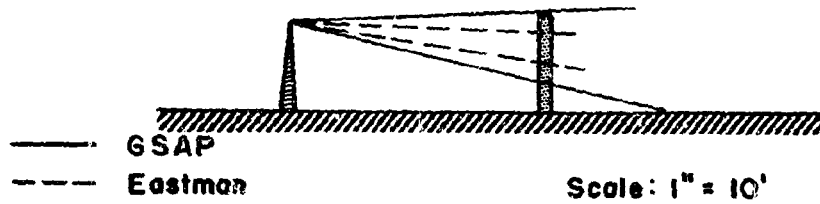
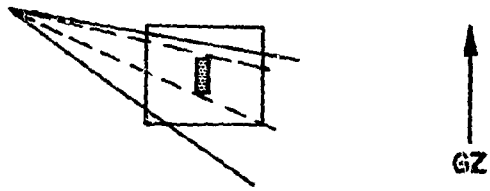

Project 8.1B-2

Camera:	GSAP	Eastman	Distance to GZ:	7701'
F <sub>r</sub> /Sec:	63	531	Vertical Angle:	-11°/-12°
Lens:	18mm	25cm	EG&G Station No:	9.11g
Film:	KC	EX	Film Number:	16653
Tower:	6' 3"	6' 3"		16654

Fig. B.29 USAF Aircraft Component Studies

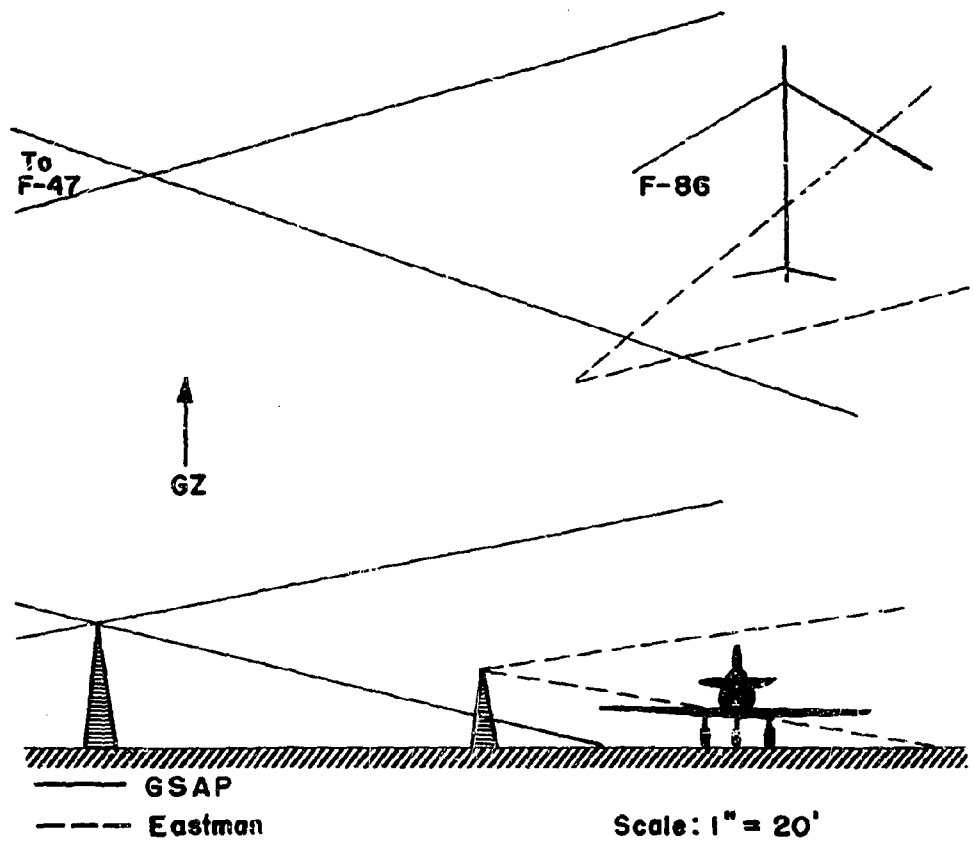

Project 8.11

Camera:	GSAP	Eastman	Distance to GZ:	2986'
Fr/Sec:	65	44.4	Vertical Angle:	-8°/0°
Lens:	18mm	25mm	EG&G Station No:	9.11a/b
Film:	MF	MF	Film Number:	16644
Tower:	18' 9"	11' Pier		16645
				16646

Fig. B.30 USAF Aircraft Studies

UNCLASSIFIED

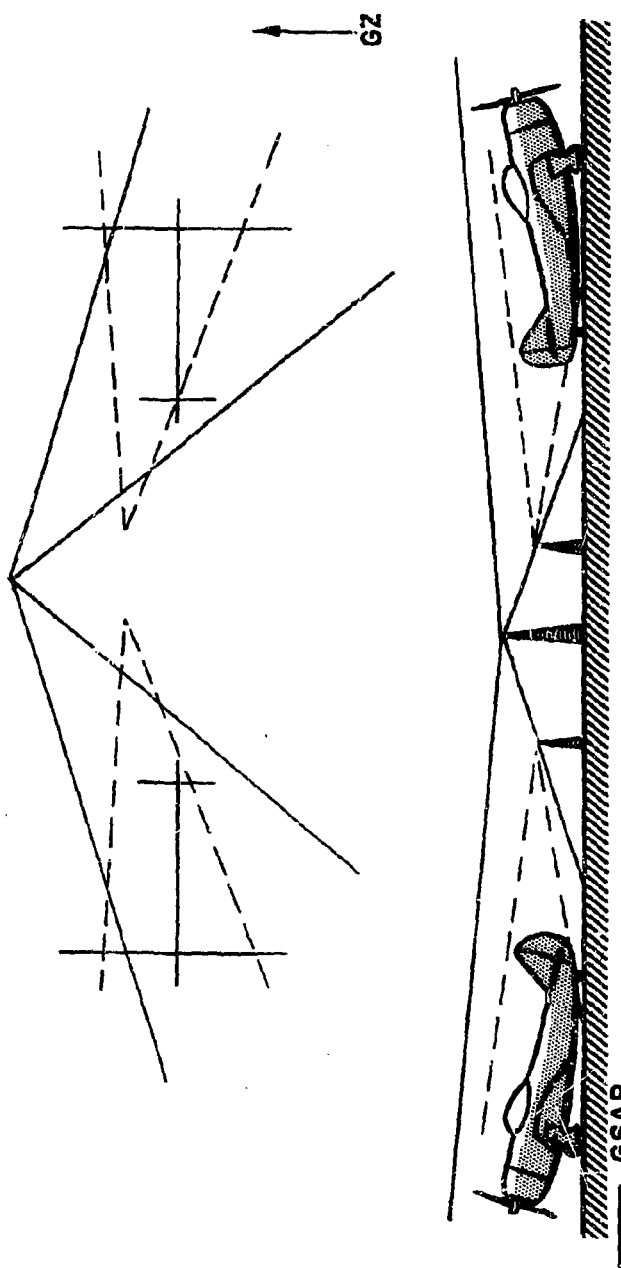

Scale: 1" = 20'

Project 8.1M (a)	Project 8.1X (b)
Camera: GSAP	Camera: Eastman Eastman
Fr/Sec: 63	Fr/Sec: 578
Distance to GZ: 594.7'	Distance to GZ: 594.7'
Vertical Angle: -6.0°	Vertical Angle: 478
EG&G Station No: 9.11c	EG&G Station No: 9.11d/e
16647	16649
Film: KG	Film: FZ
Film Number: 16648	Film Number: 16650
Tower: 18' 9"	Tower: 6' Pier 6' Pier

Fig. B.31 USAF Aircraft Studies

CONFIDENTIAL

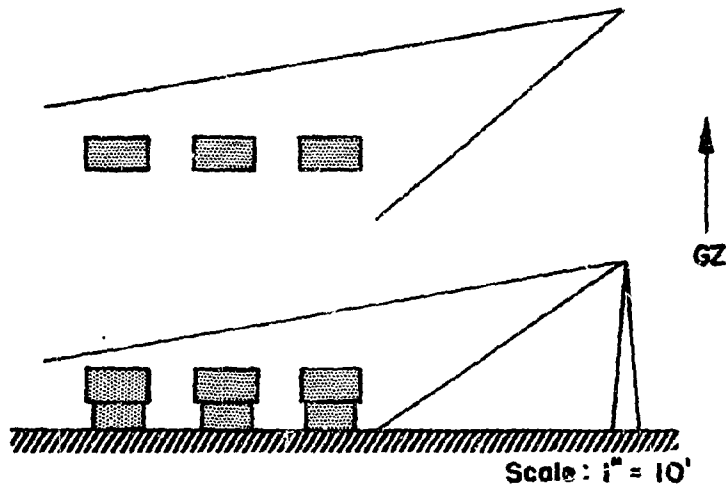

Project 8.5a

Camera:	GSAP	Distance to GZ:	5717'
Fr/Sec:	64	Vertical Angle:	-15.0°
Lens:	18mm	EG&G Station No:	9.13a
Film:	KC	Film Number:	16659
Tower:	11' 3"		16660

Project 8.5c

Camera:	GSAP	Distance to GZ:	4725'
Fr/Sec:	64	Vertical Angle:	-15.0°
Lens:	18mm	EG&G Station No:	9.13c
Film:	KC	Film Number:	16661
Tower:	11' 3"		16662

Project 8.5d

Camera:	GSAP	Distance to GZ:	3054'
Fr/Sec:	64	Vertical Angle:	-15.0°
Lens:	18mm	EG&G Station No:	9.13d
Film:	MF	Film Number:	16663
Tower:	11' 3"		16664

Fig. B.32 USA QMC Thermal Studies

**UNCLASSIFIED**

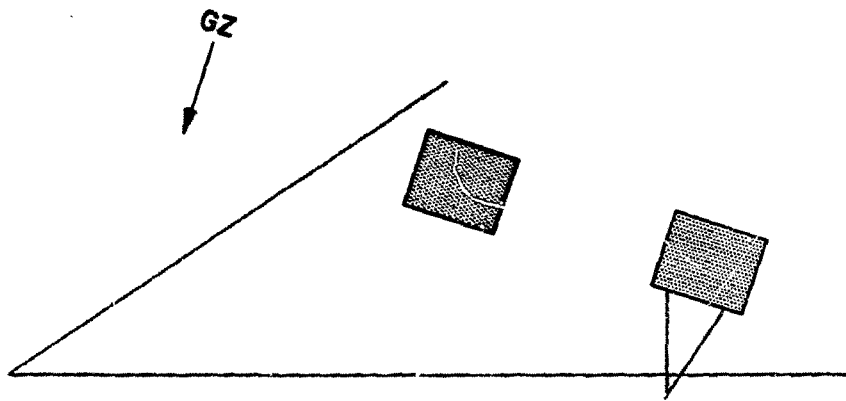

Scale: 1" = 2'

Camera:	Project 8.11a (Left Station)	Distance to GZ:	5706'
Fr/Sec:	GSAP	Vertical Angle:	-5.00
Lens:	16"	EG&G Station No:	9.14a
Film:	18mm	Film Number:	16665
Tower:	KC		16666
	11' 3"		
Camera:	Project 8.11a (Right Station)	Distance to GZ:	5706'
Fr/Sec:	GSAP	Vertical Angle:	-8.50
Lens:	16"	EG&G Station No:	9.14a
Film:	18mm	Film Number:	16673
Tower:	KC		16674
	11' 3"		

\*Time sequence photography used on one camera at each station.

Fig. B.33 AFSWP Thermal Studies

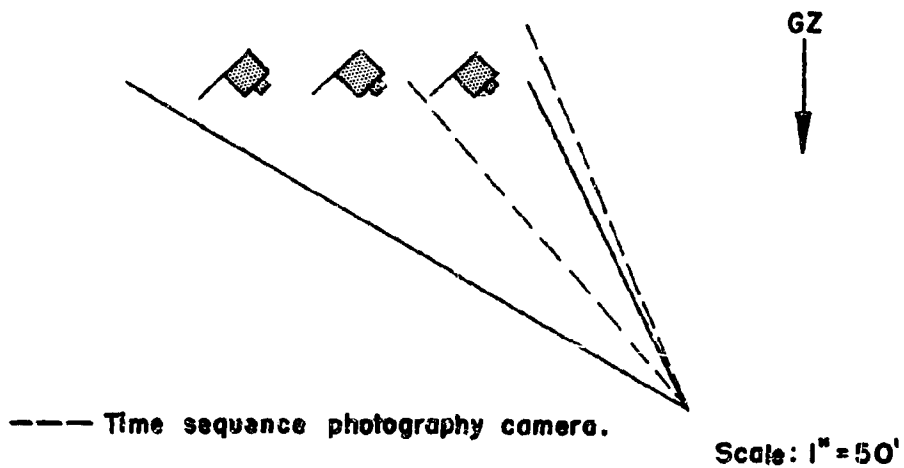

Project 8.11a

Camera:	GSAP	Distance to GZ:	7690'
Fr/Sec:	16	Vertical Angle:	-1.0°
Lens:	50mm/18mm	EG&G Station No:	9.14b
Film:	KC	Film Number:	16667
Tower:	11' 3"		16668

Fig. B.34 AFSNP Thermal Studies

**UNCLASSIFIED**

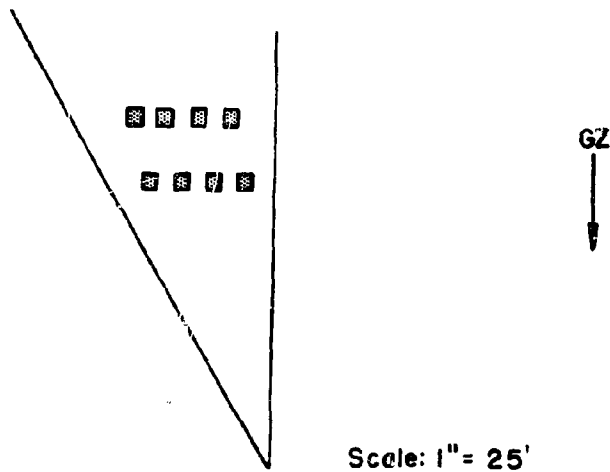

Project 8.11b

Camera:	GSAP	Distance to GZ:	7690'
Fr/Sec:	16*	Vertical Angle:	-7.0°
Lens:	18mm	EG&G Station No:	9.14d
Film:	KC	Film Number:	16871
Tower:	11' 3"		16872

\*Time sequence photography used on one camera.

Fig. B.35 AFSWP - USFS Thermal Studies

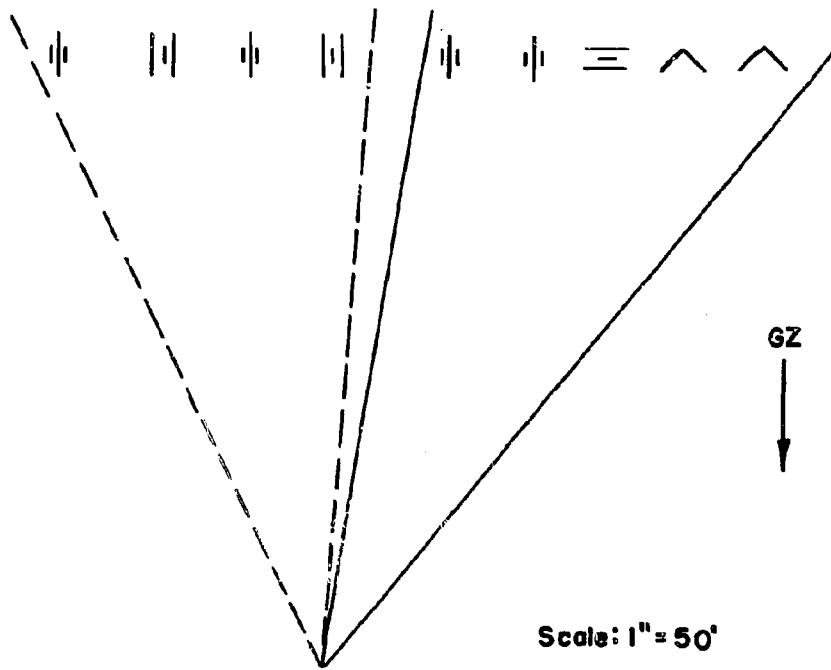

Project 8.11b

Camera:	GSAP	Distance to GZ:	7690'
Fr/Sec:	16*	Vertical Angle:	0°
Lens:	18mm	EG&G Station No:	9.14c
Film:	KC	Film Number:	16669
Tower:	11' 3"		16670

\*Time sequence photography used on both cameras.

Fig. B.36 AFSWP - USFS Thomas' Studies

**UNCLASSIFIED**



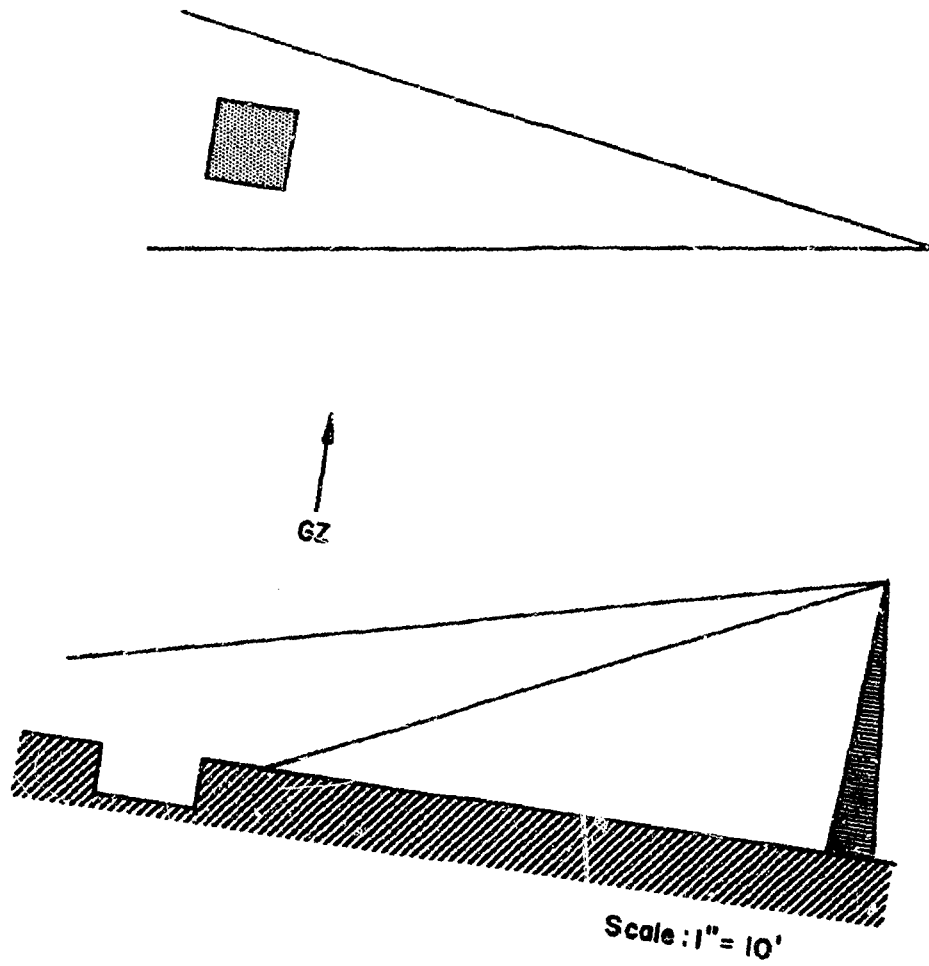

Camera:  
Fr/Sec:  
Lens:  
Film:  
Tower:

GSAP  
64  
40mm  
MF  
18' 9"

Project 9.1G

Distance to GZ: 1697'  
Vertical Angle: -22.0°  
EG&G Station No: 9.15a  
Film Number: 16675  
16676

Fig. B.37 AFSWP Foxhole Studies

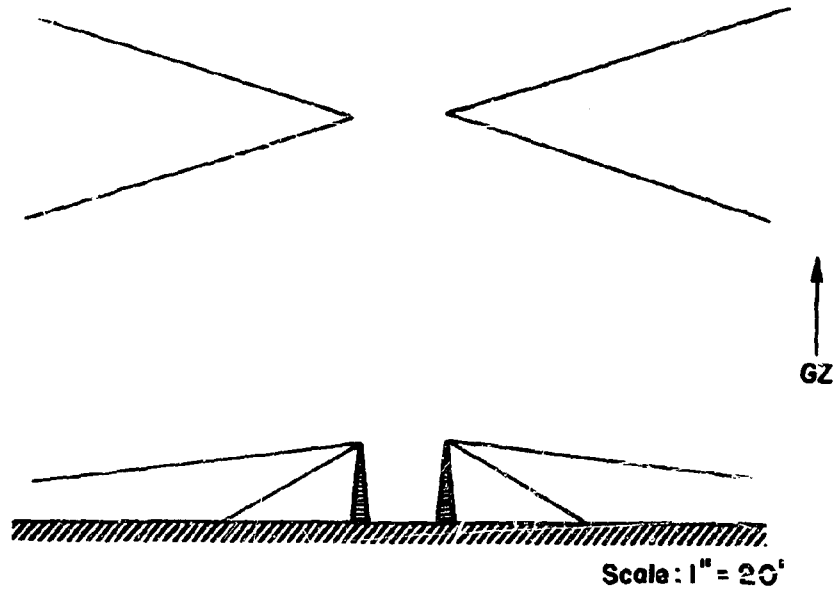

Project 9.7a & b

Camera:	GSAP	Distance to GZ:	840'
Fr/Sec:	64	Vertical Angle:	-22.0°
Lens:	18mm	EG&G Station No:	9.17a/b
Film:	MF	Film Number:	16689
Tower:	11' 3"		16690
			16691
			16692

Project 9.7c & d

Camera:	GSAP	Distance to GZ:	2610'
Fr/Sec:	64	Vertical Angle:	-22.0°
Lens:	18mm	EG&G Station No:	9.17c/d
Film:	MF	Film Number:	16693
Tower:	11' 3"		16694
			16695
			16696

Fig. B.38 AFSWP Stabilization Studies

**UNCLASSIFIED**

## APPENDIX C

### SHOT 10 CAMERA STATIONS

#### C.1 GENERAL

The photographic plan as implemented on Shot 10 is set forth in this appendix. Preceding this plan is a summary of the cameras giving in detail the various camera parameters which may be useful to individual project personnel for a detailed analysis of their film.

#### C.2 FORM

Preceding the camera layout sketches is a short resume of the photographic coverage of the project.

The project resume is divided into four sections, namely, purpose, scope, treatment, and comment. This resume should be digested by the reader before making any analysis of the project photography. In addition, any unusual events which were noticed by the authors are recorded as comments.

TABLE C.1 - Shot 10 Camera Data

Project No	EC&G Sta.	Camera Data						
		Type & No	Focus (Ft)	Aperture (f-Stop)	Frames/Second	Filter		Marker (cps)
						MD	W	
1.2	9.1a	E-7	Inf	5.6	523	1	-	11.94
1.2	9.1a	E-17	Inf	4.0	457	-	-	11.93
1.2	9.1b	MH-15	Inf	11.0	102	-	12	100
1.2	9.1b	MH-16	Inf	11.0	99	-	12	100
1.2	9.1b	MH-4	Inf	5.6	100	-	12	100
1.2	9.1c	MH-11	Inf	4.0	100	-	12	11.65
1.2	9.1c	MH-17	Inf	2.7	91	-	12	11.40
1.2	9.1d	MH-8	Inf	2.3	108	-	-	11.52
1.2	9.1e	MH-14	Inf	2.7	100	-	12	100
1.2	9.1f	MH-6	Inf	11.0	1*	-	12	100
1.2	9.1f	MH-5	Inf	4.0	99	-	12	100
1.2	9.1f	MH-24	Inf	11.0	100	1	12	100
3.6a	9.3g	G-48	Inf	2.5	62	-	-	-
3.6a	9.3g	G-50	Inf	2.5	63	-	-	-
3.6c	9.3e	G-178	Inf	2.5	65	-	-	-
3.6c	9.3e	G-15	Inf	2.5	62	-	-	-
3.6d	9.3f	G-12	Inf	2.5	58	-	-	-
3.6d	9.3f	G-16	Inf	2.5	69	-	-	-
3.6f	9.3d	G-18	Inf	2.5	64	-	-	-
3.6f	9.3d	G-22	Inf	4.0	65	-	-	-
3.6g	9.3e	G-170	Inf	4.0	68	-	-	-
3.6g	9.3e	G-185	Inf	2.5	66	-	-	-
3.6i	9.3a	G-159	Inf	11.0	1*	-	-	-
3.6i	9.3a	G-160	Inf	5.6	63	-	-	-
3.6j	9.3b	G-162	Inf	5.6	62	-	-	-
3.6j	9.3b	G-164	Inf	11.0	1*	-	-	-
3.6l	9.3i	G-21	Inf	2.5	63	-	-	-
3.6l	9.3i	G-24	Inf	2.5	64	-	-	-
3.6p	9.3h	G-39	Inf	2.5	64	-	-	-
3.6p	9.3h	G-37	Inf	2.5	64	-	-	-
3.16a	9.4a	F-5	18	2.0	1720	-	-	200
3.16a	9.4a	G-1	18	2.5	60	-	-	-
3.16a	9.4b	F-15	18	2.0	1627	-	-	200
3.16a	9.4b	G-2	18	2.5	60	-	-	-
3.18	9.15b	G-44	Inf	8.0	64	-	-	-

UNCLASSIFIED

TABLE C.1 (Continued)

Project No	EG&G Sta.	Camera Data						
		Type & No	Focus (Ft)	Aperture (f-Stop)	Frames/Second	Filter ND	W	Marker (cps)
3.18	9.15b	G-45	Inf	5.6	64	-	-	-
3.19	9.5e	MH-21	Inf	2.3	F*	-	-	-
3.19	9.5e	MH-22	Inf	2.3	94	-	-	11.73
3.21e	9.6a	G-29	Inf	16.0	D*	-	-	-
3.21e	9.6a	G-13	Inf	16.0	D*	-	-	-
3.21i	9.6b	G-31	Inf	11.0	59	-	-	-
3.21i	9.6b	G-14	Inf	5.6	61	-	-	-
3.21k	9.6c	G-33	Inf	2.5	64	-	-	-
3.21k	9.6c	G-17	Inf	2.5	66	-	-	-
3.21y	9.6h	G-52	Inf	5.6	63	-	-	-
3.21y	9.6h	G-19	Inf	2.5	65	-	-	-
3.21bb	9.6g	G-47	Inf	5.6	60	-	-	-
3.21bb	9.6g	G-53	Inf	2.5	65	-	-	-
3.22a	9.7c	G-122	Inf	11.0	59	-	-	-
3.22a	9.7c	G-101	Inf	5.6	64	-	-	-
3.24d	9.15c	G-121	Inf	8.0	60	-	-	-
3.24d	9.15c	G-124	Inf	4.0	66	-	-	-
CDR-1	9.8a	G-153	40	11.0	D*	-	-	-
CDR-1	9.8a	G-37	40	5.6	D*	-	-	-
CDR-2	9.8b	G-38	Inf	11.0	D*	-	-	-
CDR-2	9.8b	G-183	Inf	5.6	D*	-	-	-
CDR-3	9.8c	G-182	45	11.0	D*	-	-	-
CDR-3	9.8c	G-36	45	5.6	D*	-	-	-
CDR-4	9.9g	G-83	35	4.0	62	-	-	-
CDR-4	9.9g	G-91	35	2.5	58	-	-	-
CETG-1	9.9d	G-113	36	5.6	60	-	-	-
CETG-1	9.9d	G-89	36	2.5	62	-	-	-
CETG-2	9.9b	G-22	52	5.6	59	-	-	-
CETG-2	9.9b	G-35	52	2.5	62	-	-	-
CETG-3	9.9a	G-64	Inf	5.6	59	-	-	-
CETG-3	9.9a	G-66	Inf	2.5	64	-	-	-
CETG-4	9.9c	G-74	Inf	5.6	62	-	-	-
CETG-4	9.9c	G-76	Inf	2.5	62	-	-	-
8.1B	9.11f	E-2	17	2.8	519	-	-	11.80
8.1B	9.11f	G-42	17	5.6	62	-	-	-

UNCLASSIFIED

TABLE C.1 (Continued)

Project No	EG&G Sta.	Camera Data						
		Type & No	Focus (Ft)	Aperture (f-Stop)	Frames/Second	Filter		Marker (cps)
						ND	W	
8.1B	9.11g	E-14	12	5.6	602	-	-	11.80
8.1B	9.11g	G-138	12	8.0	63	-	-	-
8.1B	9.11h	E-19	17	2.8	595	-	-	11.66
8.1B	9.11h	G-146	17	8.0	61	-	-	-
8.1L	9.11a	G-70	Inf	5.6	60	-	-	-
8.1L	9.11b	E-4	27	1.9	448	-	-	11.85
8.1M	9.11c	G-120	45	5.6	61	-	-	-
8.1M	9.11c	E-15	30	2.8	519	-	-	11.54
8.4a	9.12a	R-4	Sphere	1.9	F*	-	K2	Clack
8.4b	9.12c	R-3	Sphere	1.9	2/Min	-	K2	Clack
8.5a	9.13a	G-116	32	5.6	63	-	-	-
8.5a	9.13a	G-98	36	5.6	63	-	-	-
8.5c	9.13c	G-171	36	8.0	58	-	-	-
8.5c	9.13c	G-176	30	8.0	60	-	-	-
8.5d	9.13d	G-78	35	2.8	61	-	-	-
8.5d	9.13d	G-152	30	2.8	66	-	-	-
9.7a	9.17a	G-26	32	16.0	D*	1	-	-
9.7a	9.17a	G-168	32	16.0	D*	-	-	-
9.7b	9.17b	G-169	32	16.0	D*	1	-	-
9.7b	9.17b	G-172	32	16.0	D*	-	-	-
9.7c	9.17c	G-173	32	8.0	63	-	-	-
9.7c	9.17c	G-175	32	2.5	64	-	-	-
9.7d	9.17d	G-177	32	8.0	65	-	-	-
9.7d	9.17d	G-184	32	2.5	65	-	-	-

\* L - Lens cap not removed.

D - Camera installation destroyed by blast.

F - Camera electrical system failure.

UNCLASSIFIED

### Project 1.2

**Purpose:** To determine the time of arrival of the shock front by photographing it against a background of vertical rocket (smoke) trails. To photograph the shock front as it moves along the blast line, showing the path of the triple point and other blast effects phenomenon. To photograph the shock front over the smoke layer.

**Scope:** Quantitative information was requested by this project. Consequently, large frame, high resolution cameras were used in all cases except where higher frame rates were desired.

**Treatment:** Cameras were set a considerable distance from the area being photographed, and, where detail was desired, long focal length lenses were used. This was to avoid the expense and difficulty of constructing camera stations nearer to ground zero. Timing marks were put on all films. The rocket photography was attempted on Shots 1, 4, 9, 10, and 11. The shock front photography was attempted on Shots 9 and 10.

**Comments:** A shock front may be seen only by the effect it produces. That effect which enables one to photograph a shock front in air is the refraction of light passing through the front. This refraction is caused by the greater density of the air at the front than the air around it. Rocket trails, by providing a continuous vertical discontinuity, served to increase the visibility of this effect. Where the shock front is exceedingly strong, it can be photographed without this background, and in fact, the success of the photography was roughly proportional to the yield of the shots.

### Project 3.6

**Purpose:** To observe the gross mode of response of railroad rolling stock to shock.

**Scope:** Quantitative information was desired as object displacement versus time measurements were to be made from these films.

**Treatment:** As only gross motion of equipment, not damage to individual parts of an item was desired, the layout of the cameras was such as to provide one camera relatively close to the object and another farther away covering a wider field of view.

**Comments:** In order to reduce the thermal smoke from the railroad cars, they were sprayed with sodium silicate several days before shot day. The photography for this project was,

in general, excellent and the films show such detailed information.

#### Project 3.16

**Purpose:** To observe photographically the failure of individual glass panes as well as failure of the window as a whole.  
**Scope:** The opening of the window as a whole was to be measured from the film. Otherwise, analysis was to be primarily qualitative.  
**Treatment:** This station was somewhat complicated from an electrical standpoint. Eleven kilowatts of incandescent lighting was provided for each window, and a blast switch was used to start the Fastax cameras. A 200 cycle timing marker generator was required to furnish timing marks for the Fastax cameras. This needed 115 volts AC which was furnished by a battery driven inverter.  
**Comments:** The photography for this project was excellent.

#### Project 3.18

**Purpose:** To record the effects of blast on a typical minefield.  
**Scope:** Analysis of the photography was to be qualitative.  
**Treatment:** Normal.  
**Comments:** All films for the project were ruined from radiation.

#### Project 3.19

**Purpose:** To record the particle displacement by the blast wind above the forest stand.  
**Scope:** Quantitative results were desired for particle displacement versus time. Timing marks were put on all films.  
**Treatment:** Large frame cameras giving high resolution were used for this project.  
**Comments:** The photographic results were excellent.

#### Project 3.21

**Purpose:** To record gross movement of ordnance equipment by the blast wave.

**UNCLASSIFIED**



**Scope:** Quantitative measurements were desired for stations 3.2le and 3.2lk while qualitative data were desired for the remainder of the stations.

**Treatment:** No stabilization was used at station 3.2le because of its close proximity to ground zero.

**Comments:** In general, the results were fair; the dust from the blast wave enveloping the targets and the cameras all too quickly. The films of the targets farthest from ground zero were best.

#### Project 3.22

**Purpose:** To record movement of a Bailey Bridge by the blast wave.

**Scope:** It was desired to make displacement versus time measurements from the film.

**Treatment:** A 17 ft tower was used to cover the bridge.

**Comments:** The photography for this station was poor as the object was too close to ground zero.

#### Project 3.24

**Purpose:** To record movement of a LVT by the blast wave.

**Scope:** It was desired to make displacement versus time measurements from the film.

**Treatment:** Normal.

**Comments:** The results of this photography were poor as the target was too close to ground zero.

#### Project CDR (Camp Desert Rock)

**Purpose:** To record the effects of blast and thermal radiation on several items of military equipment.

**Scope:** Coverage was primarily pictorial.

**Treatment:** Normal.

**Comments:** The results were very poor because of the loss of the photographic equipment and the target from the blast.

#### Project AEC (Program 26)

**Purpose:** To observe the effects of blast and thermal radiation on typical civilian vehicles.

**Scope:** Coverage was primarily pictorial.  
**Treatment:** Normal.  
**Comments:** This effort was conducted for the AEC.

#### Project 8.1

**Purpose:** To observe the effects of blast and thermal radiation on parked aircraft and aircraft components.  
**Scope:** Some displacement versus time measurements were desired. The principal part of the photographic analysis was to be qualitative.  
**Treatment:** Cameras were placed extremely close to the objects because of the small disturbances it was desired to observe (wrinkling of the aircraft skin). High speed Eastman cameras in lead shielded boxes were used in this program. These were mounted vertically and observed their targets by means of a 45 degree angle mirror.  
**Comments:** The results of this photography were excellent showing the desired information in detail. Color was used very successfully at the most distant station. Care must be exercised when printing from the negatives exposed through the 45 degree mirrors since these produced left-right reversal. This was compensated for on the prints originally distributed.

#### Project 8.4

**Purpose:** To determine the dimensions and uniformity of a smoke screen.  
**Scope:** Analysis of the photography was to be quantitative.  
**Treatment:** Plan dimensions of the screen were to be obtained from aerial still photos exposed within seconds of zero time from aircraft flying over ground zero. Height of the smoke was to be obtained from 35 mm motion picture cameras used for Project 1.2. These were looking down the blast line and covered the smoke screen in their field of view. At the stations where it was desired to determine the uniformity of the smoke screen, a 35 mm Robot camera was employed looking vertically down into a silvered spherical globe. This took two exposures/min starting 15 min. before zero time, and gave complete hemispherical coverage.  
**Comments:** The direction of ground zero was defined by the vertical pole in the field of view. The bright object in the first few pictures was the sun.

**UNCLASSIFIED**

#### Project 8.5

**Purpose:** To observe the effects of thermal radiation on animals in uniform and, in addition, to observe the effects of blast on any fires which may have been started in the uniforms.

**Scope:** The analysis of the photography was to be qualitative.

**Treatment:** Normal. Color film was used at the two most distant stations in order to be able to observe fires in clothing. Long focal length lenses were used on this shot to increase the image size.

**Comments:** Because of the narrow latitude of the color film, the early thermal phase was almost blanked out. However, the thermal phase just prior to the blast wave showed the desired information.

#### Project 9.7

**Purpose:** To provide evidence of the values of various types of soil stabilization for photographic purposes.

**Scope:** Film analysis will attempt to determine the amount of dust and thermal smoke emanating from each test surface by measuring height of reference markers obscured.

**Treatment:** The cameras were pointed at a reference marker which was set in the middle of the stabilized plot.

**Comments:** In general, the photography is fair, although the short transit time between the thermal and the arrival of the shock wave precludes accurate and prolonged information.

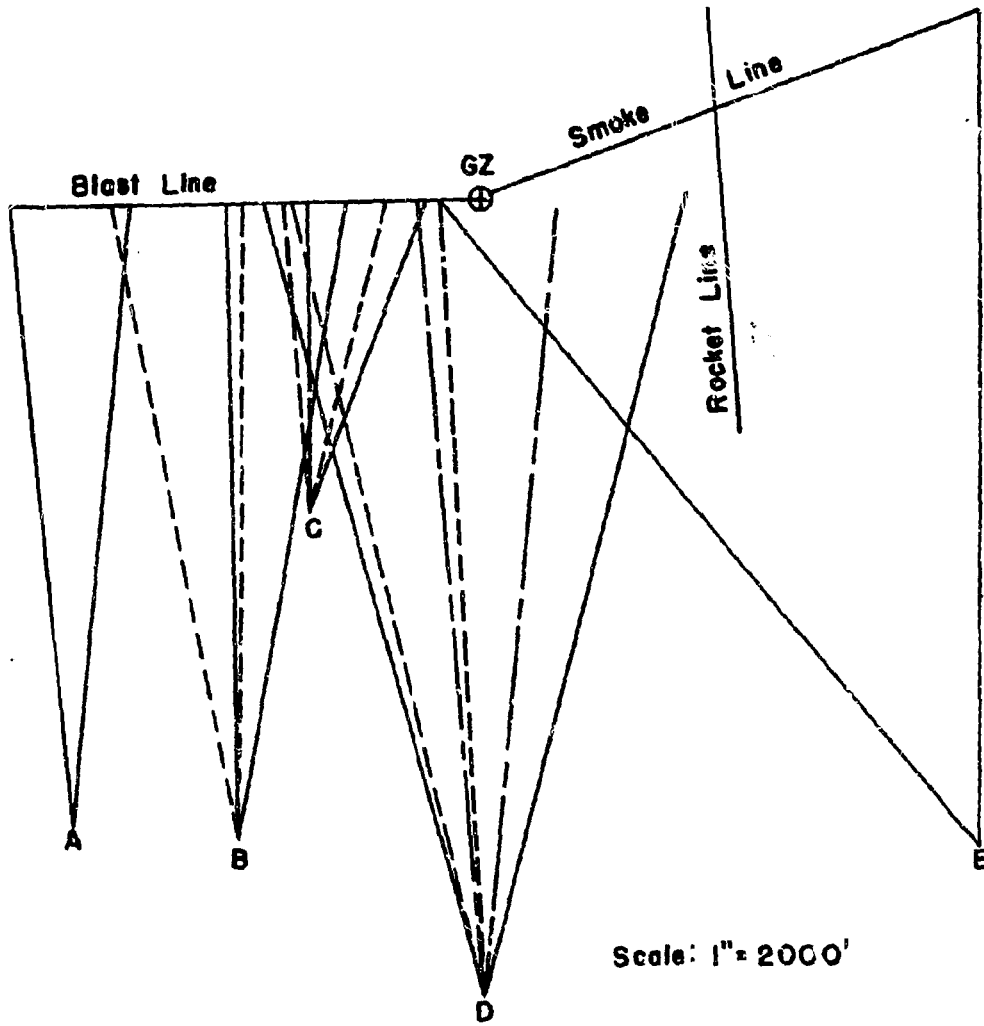

Scale: 1" = 2000'

Project 1.2 (Diagram A)

Camera:	Mitchell	Distance to GZ:	9400'
Fr/Sec:	100	Vertical Angle:	0°
Lens:	152mm	EG&G Station No:	9.1e
Film:	MF	Film Number:	16709
Tower:	Trailer		

Fig. C.1 NOL Blast & Shock Studies

**UNCLASSIFIED**



CLASSIFIED BY: [illegible]  
 DATE: [illegible]

Project 1.2 (Diagram B)

Camera:	Mitchell	Distance to GZ:	8500'
Fr/Sec:	100/91	Vertical Angle:	0°
Lens:	152mm/152mm	EG&G Station No:	9.1c
Film:	MF	Film Number:	16706
Tower:	28'		16707

Project 1.2 (Diagram C)

Camera:	Eastman	Distance to GZ:	4600'
Fr/Sec:	523/467	Vertical Angle:	0°
Lens:	102mm/152mm	EG&G Station No:	9.1a
Film:	MF	Film Number:	16701
Tower:	18' 9"		16702

Project 1.2 (Diagram D)

Camera:	Mitchell	Distance to GZ:	10000'
Fr/Sec:	102/99/100	Vertical Angle:	0°
Lens:	152mm/152mm/50mm	EG&G Station No:	9.1b
Film:	MF	Film Number:	16703
Tower:	28'		16704
			16705

Project 1.2 (Diagram E)

Camera:	Mitchell	Distance to GZ:	9200'
Fr/Sec:	108	Vertical Angle:	0°
Lens:	35mm	EG&G Station No:	9.1d
Film:	MF	Film Number:	16708
Tower:	28'		

**UNCLASSIFIED**

~~CONFIDENTIAL~~

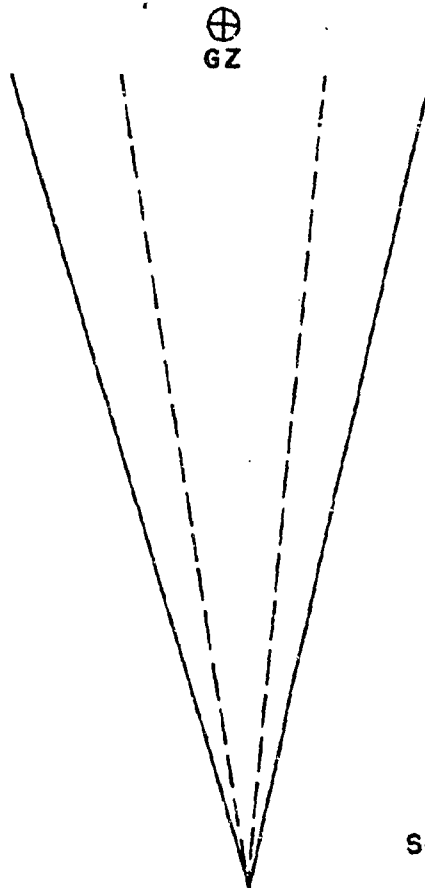

Scale: 1" = 2000'

Project 1.2

<u>Fr/Sec</u>	<u>Lens</u>	<u>Vertical Angle</u>	Camera:	Mitchell
-/99	50mm/50mm	0°	Film:	MF
100		0°	Distance to GZ:	12000'
			EG&G Station No:	9.1f
			Film Number:	16710
				16711
				16712

Note: Cameras at this station were mounted in an EG&G photo trailer.

Fig. C.2 NGL Blast and Shock Studies

**UNCLASSIFIED**

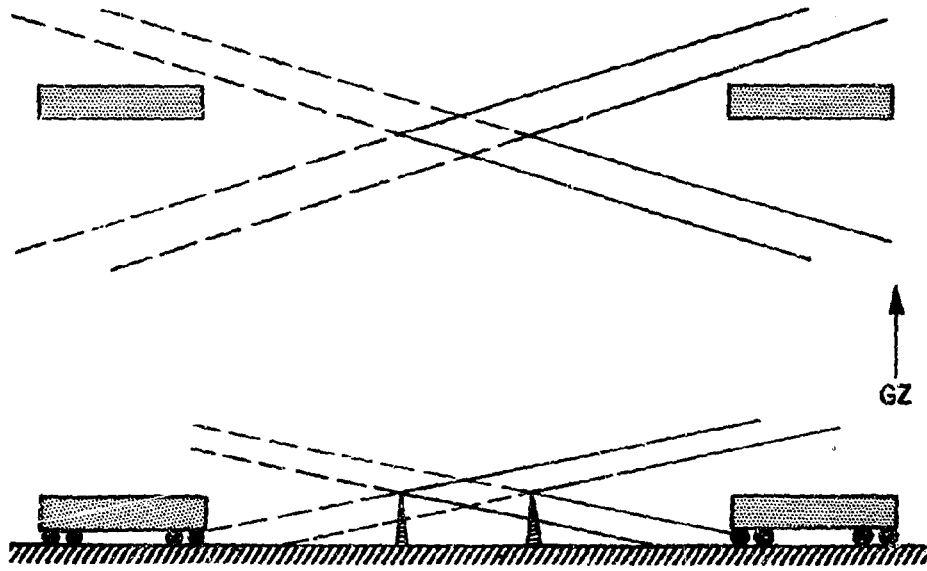

Scale: 1" = 100'

Project 3.6a

Camera:	GSAP	Distance to GZ:	6608'
Fr/Sec:	63	Vertical Angle:	-7.0°
Lens:	12mm	EG&G Station No:	9.3g
Film:	MF	Film Number:	16729
Tower:	18' 9"		16730

Fig. C.3 USAF and U. S. Army QMC Railroad Studies

**UNCLASSIFIED**



Project 3.6c & d

Camera:	GSAP	Distance to GZ:	3400'
Fr/Sec:	64	Vertical Angle:	-7°/0°
Lens:	18mm	EG&G Station No:	9.3e/f
Film:	MF	Film Number:	16722
Tower:	18' 9"		16723
			16724
			16726

Project 3.6f & g

Camera:	GSAP	Distance to GZ:	2785'
Fr/Sec:	64	Vertical Angle:	-7°/0°
Lens:	18mm	EG&G Station No:	9.3e/d
Film:	MF	Film Number:	16717
Tower:	18' 9"		16718
			16719
			16720

Project 3.6i & j

Camera:	GSAP	Distance to GZ:	1840'
Fr/Sec:	63	Vertical Angle:	-7°/0°
Lens:	18mm	EG&G Station No:	9.3a/b
Film:	MF	Film Number:	16713
Tower:	18' 9"		16714
			16715
			16716

Project 3.6l & p

Camera:	GSAP	Distance to GZ:	4380'
Fr/Sec:	64	Vertical Angle:	-7°/0°
Lens:	18mm	EG&G Station No:	9.3h/i
Film:	MF	Film Number:	16725
Tower:	18' 9"		16726
			16727
			16728

**UNCLASSIFIED**

~~CONFIDENTIAL~~



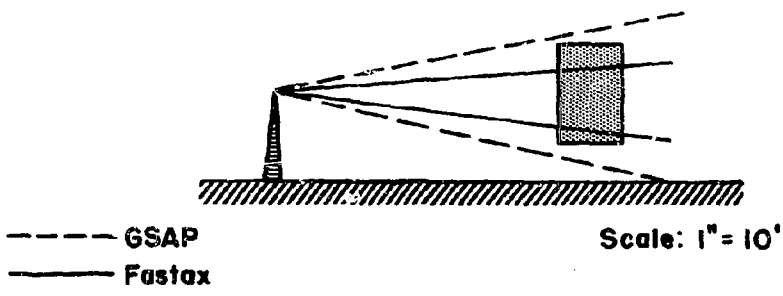
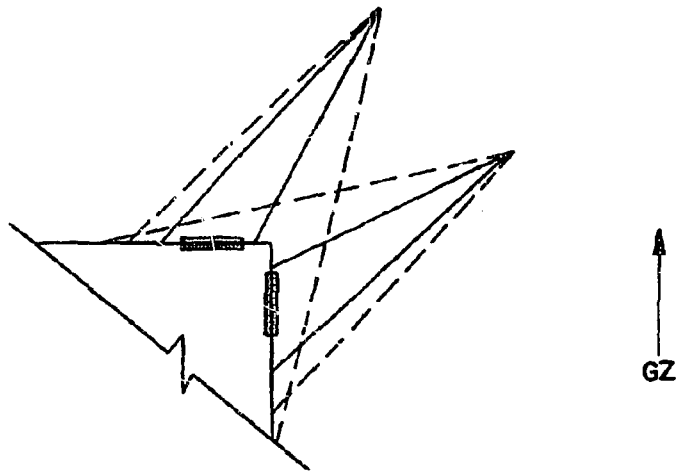

Project 3.16a

Camera:	GSAP	Fastax	Distance to GZ:	7517'
Fr/Sec:	60	1700	Vertical Angle:	0°
Lens:	18mm	35mm	EG&G Station No:	9.4a/b
Film:	MF	BK	Film Number:	16731
Tower:	6' 3"	6' 3"		16732
				16733
				16734

Fig. C.4 USN Glazing Studies

**UNCLASSIFIED**

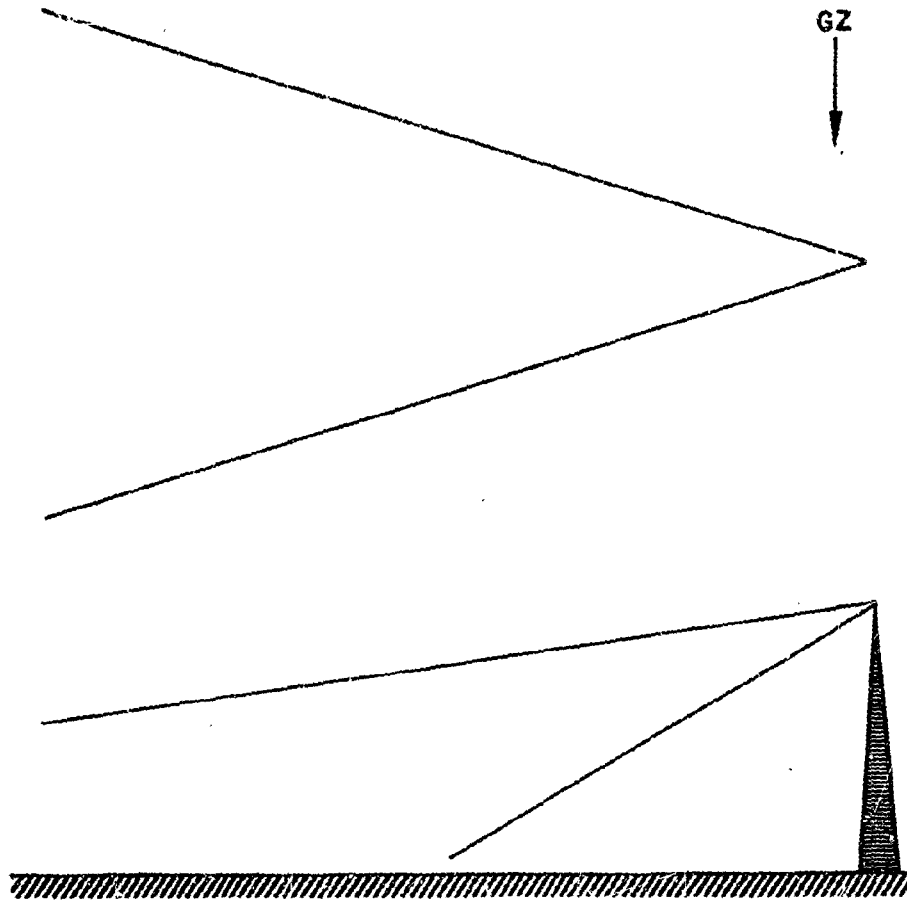

Scale: 1" = 10'

Project 3.18

Camera:	GSAP	Distance to GZ:	2275'
F <sub>r</sub> /Sec:	62	Vertical Angle:	-8.0°
Lens:	18mm	EG&G Station No:	9.15b
Film:	MF	Film Number:	16785
Tower:	18' 9"		16786

Fig. C.5 Corps of Engineers Minefield Studies

**UNCLASSIFIED**

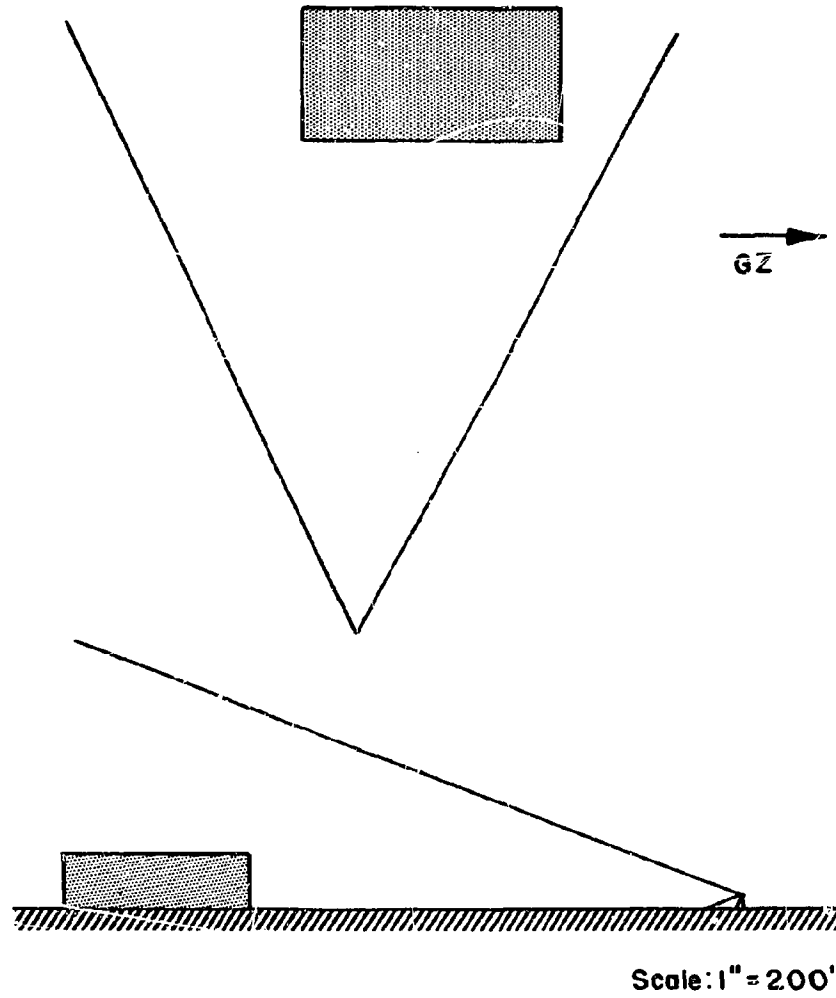

Project 3.19

Camera:	Mitchell	Distance to GZ:	6391'
Fr/Sec:	-/94	Vertical Angle:	0°
Lens:	25mm/25mm	EGG Station No:	9.5e
Film:	MF	Film Number:	16735
Tower:	18' 9"		16736

Fig. C.6 AFSWP - USFS Forest Studies

**UNCLASSIFIED**

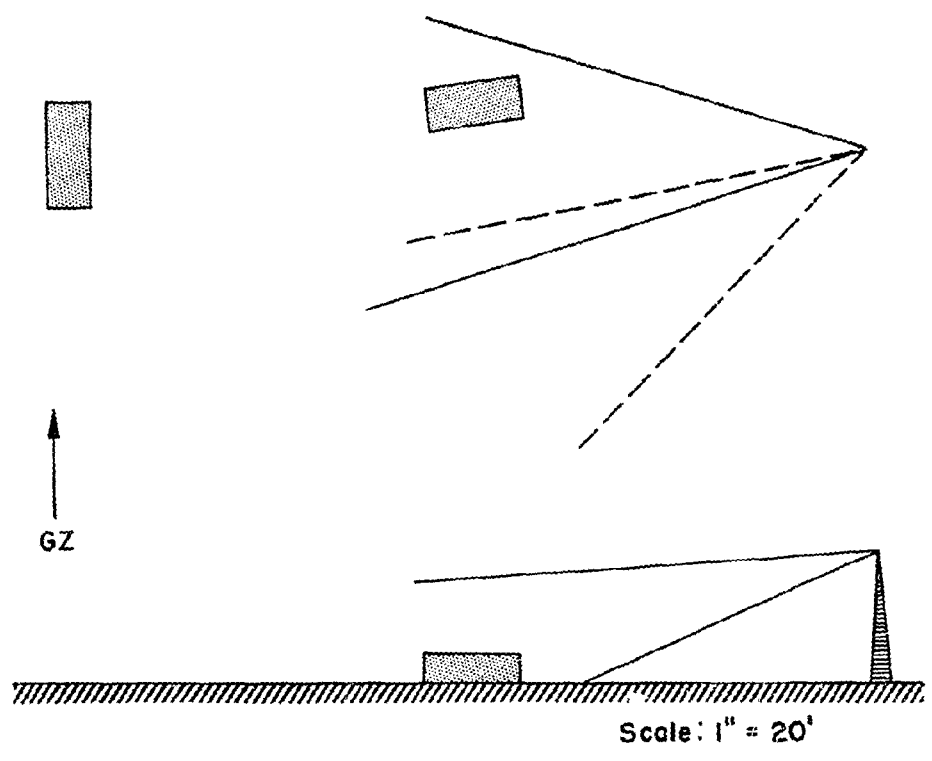

Project 3.21a

Camera:	GSAP	Distance to GZ:	1131'
Fr/Sec:	-	Vertical Angle:	-11.0°
Lens:	18mm	EG&G Station No:	9.6a
Film:	MF	Film Number:	16737
Tower:	18' 9"		16738

Project 3.21i

Camera:	GSAP	Distance to GZ:	1918'
Fr/Sec:	60	Vertical Angle:	-10.0°
Lens:	18mm	EG&G Station No:	9.6b
Film:	MF	Film Number:	16739
Tower:	18' 9"		16740

Fig. C.7. SFL V. 1. Studies

**UNCLASSIFIED**  
110

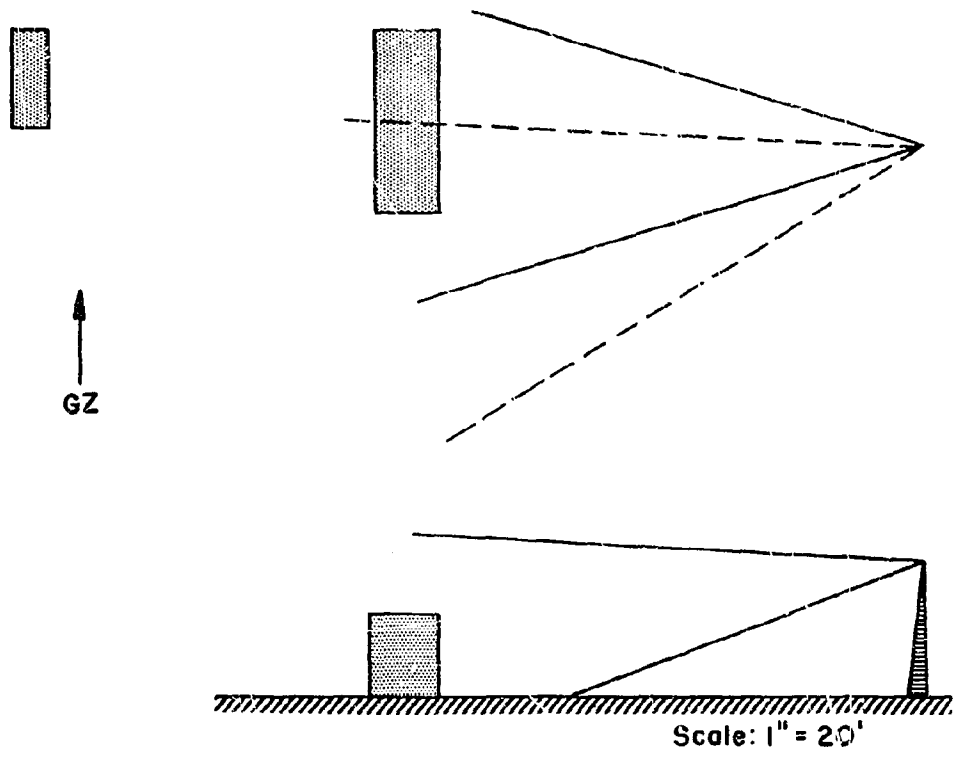

Project 3.21k

Camera:	GSAP	Distance to GZ:	4381'
Fr/Sec:	65	Vertical Angle:	0°
Lens:	18mm	EMG Station No:	9.6c
Film:	MF	Film Number:	16745
Tower:	11' 3"		16746

Fig. C.8 BRL Vehicle Studies

**UNCLASSIFIED**

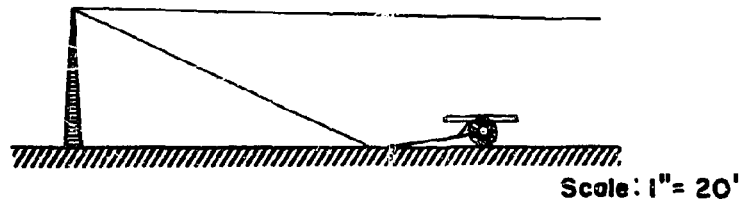
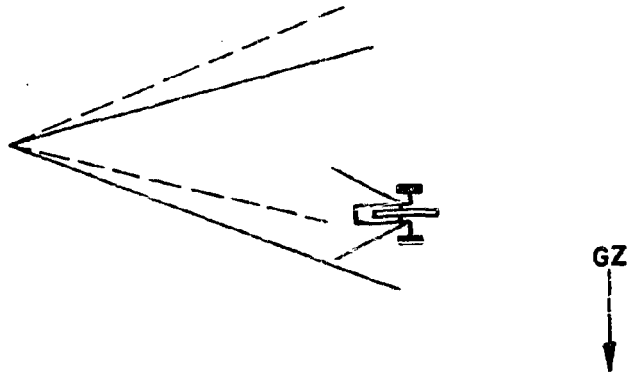

Project 3.21y

Camera:	GSAP	Distance to GZ:	2138'
Fr/Sec:	64	Vertical Angle:	-15.0°
Lens:	12mm	EG&G Station No:	9.6h
Film:	MF	Film Number:	16741
Tower:	18' 9"		16742

Fig. C.9 BRL Vehicle Studies

**UNCLASSIFIED**

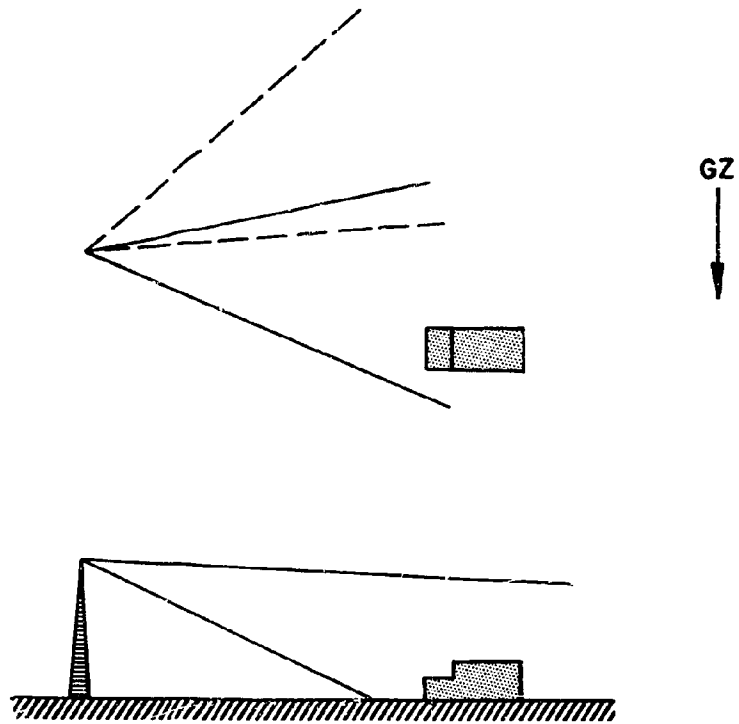

Project 3.21bb

Camera:	GSAP	Distance to GZ:	2364'
Fr/Sec:	64	Vertical Angle:	-13.0°
Lens:	18mm	EG&G Station No:	9.6g
Film:	MF	Film Number:	16743
Tower:	18' 9"		16744

Fig. C.10 BRL Vehicle Studies

**UNCLASSIFIED**



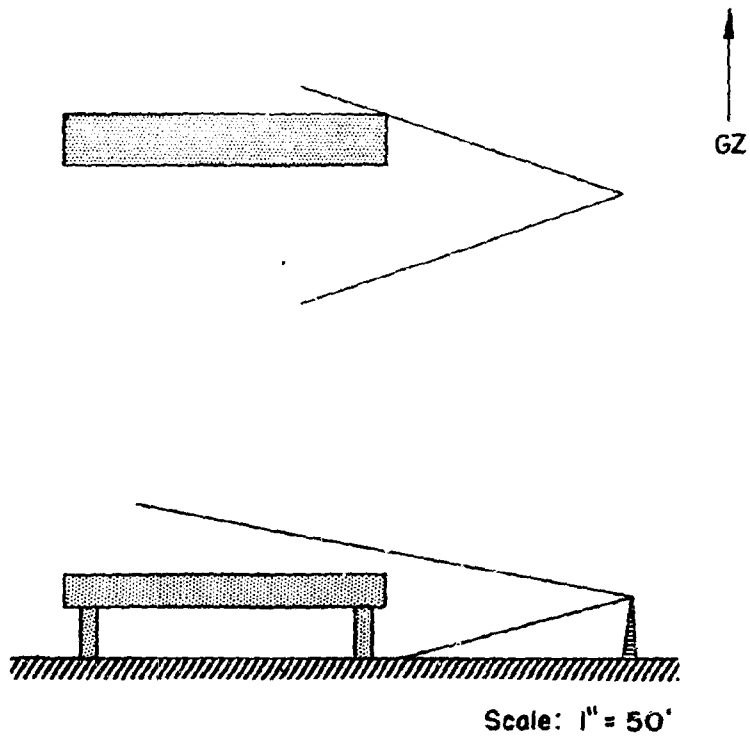

Project 3.22a

Camera:	GSAP	Distance to GZ:	1988'
Fr/Sec:	64	Vertical Angle:	0°
Lens:	18mm	EG&G Station No:	9.7c
Film:	MF	Film Number:	16747
Tower:	18' 9"		16748

Fig. C.11 Corps of Engineers Bailey Bridge Studies

**UNCLASSIFIED**



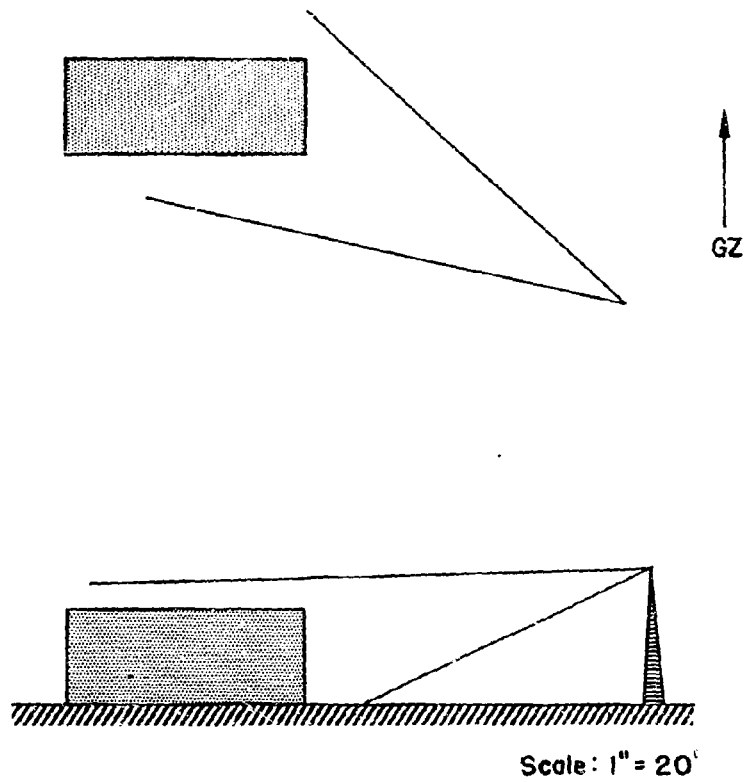

Project 3.24d

Camera:	GSAP	Distance to GZ:	1908'
Fr/Sec:	64	Vertical Angle:	-16.0°
Lens:	18mm	EG&G Station No:	2.15c
Film:	MF	Film Number:	16787
Tower:	18' 9"		16788

Fig. C.12 AFSWP - USN LVT Studies

**UNCLASSIFIED**

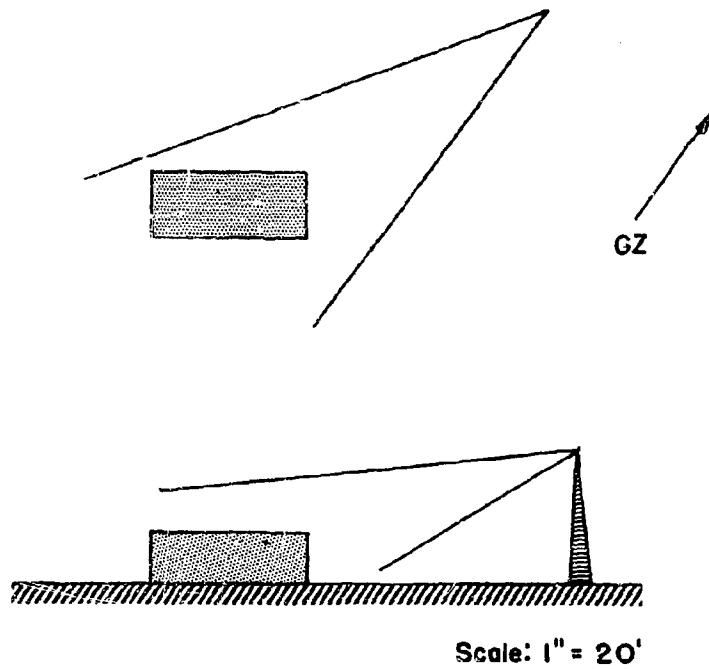

Project CDR-1

Camera: GSAP  
 Fr/Sec: -  
 Lens: 18mm  
 Film: MF  
 Tower: 18' 9"

Distance to GZ: 1541'  
 Vertical Angle: -18.0°  
 EG&G Station No: 9.8a  
 Film Number: 16749  
 16750

Fig. C.12 - Camp Desert Rock Howitzer Studies

**UNCLASSIFIED**

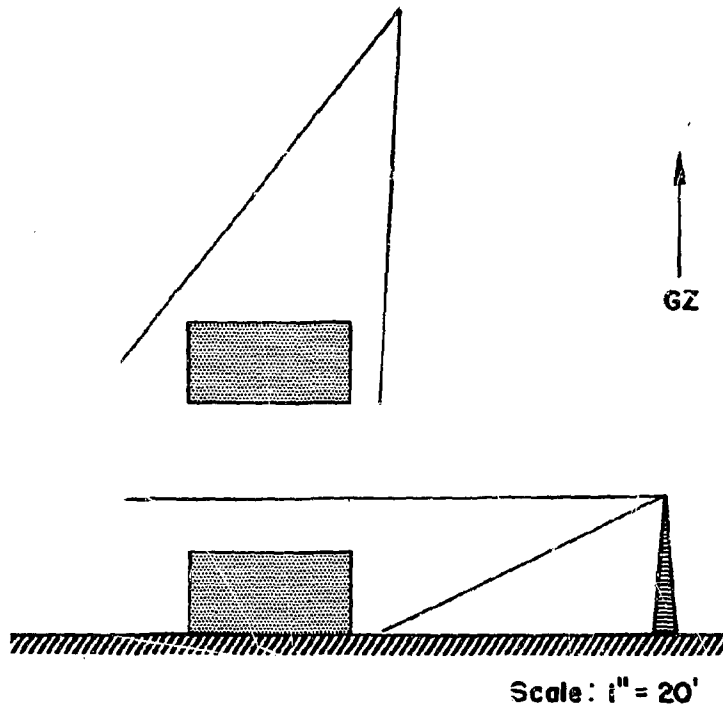

Project CDR-2

Camera: GSAP  
 Fr/Sec: -  
 Lens: 18mm  
 Film: MF  
 Tower: 18' 9"

Distance to GZ: 1546'  
 Vertical Angle:  $-16.0^{\circ}$   
 BG&G Station No: 9.8b  
 Film Number: 16751  
 16752

Fig. C.14 Camp Desert Rock Self Propelled Howitzer Studies

**UNCLASSIFIED**

123



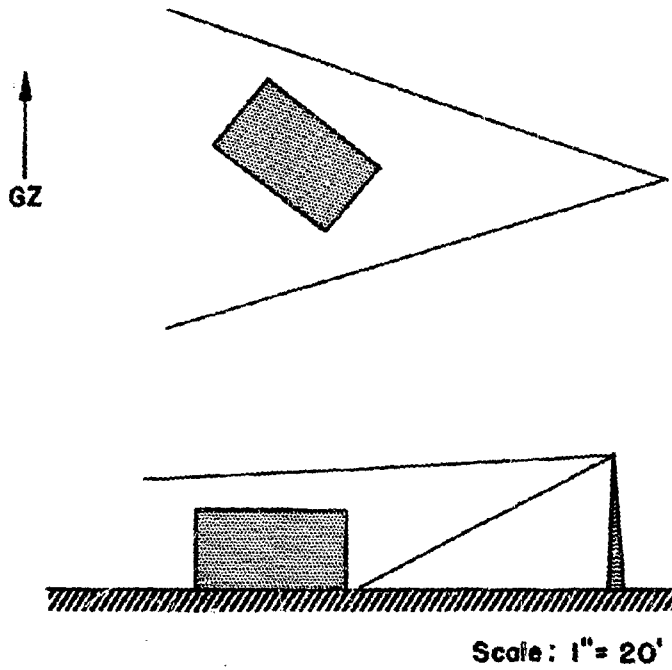

Project CDR-3

Camera:	GSAP	Distance to GZ:	1537'
F <sub>r</sub> /Sec:	-	Vertical Angle:	-16.0°
Lens:	18mm	EMG Station No:	9.8c
Film:	MF	File Number:	16753
Tower:	18' 9"		16754

Fig. C.15 Camp Desert Rock M-24 Tank Studies

**UNCLASSIFIED**  
~~CONFIDENTIAL~~

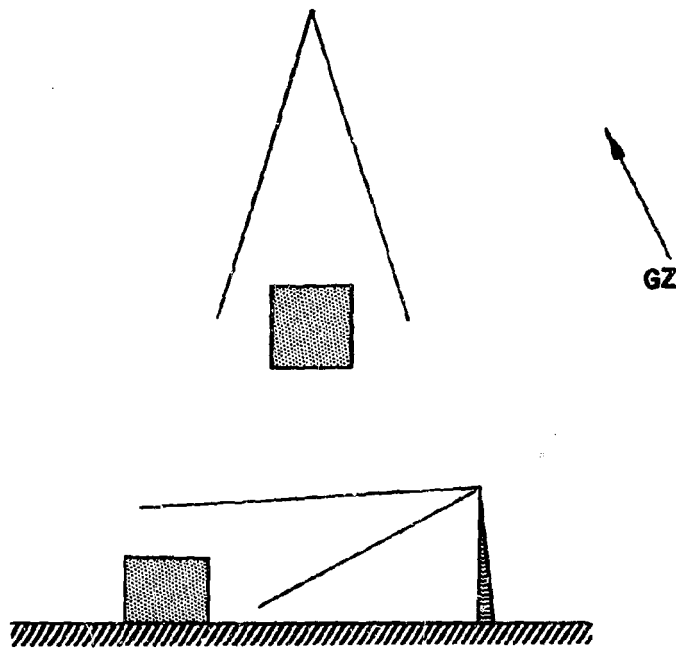

Scale: 1" = 20'

Project CDR-4

Camera:	GSAP	Distance to GZ:	4441'
F <sub>r</sub> /Sec:	60	Vertical Angle:	-23.0°
Lens:	18mm	EG&G Station No:	9.9g
Film:	MF	Film Number:	16755
Tower:	18' 9"		16756

Fig. C.16 Camp Desert Rock Wall Tent Studies

**UNCLASSIFIED**  
~~CONFIDENTIAL~~

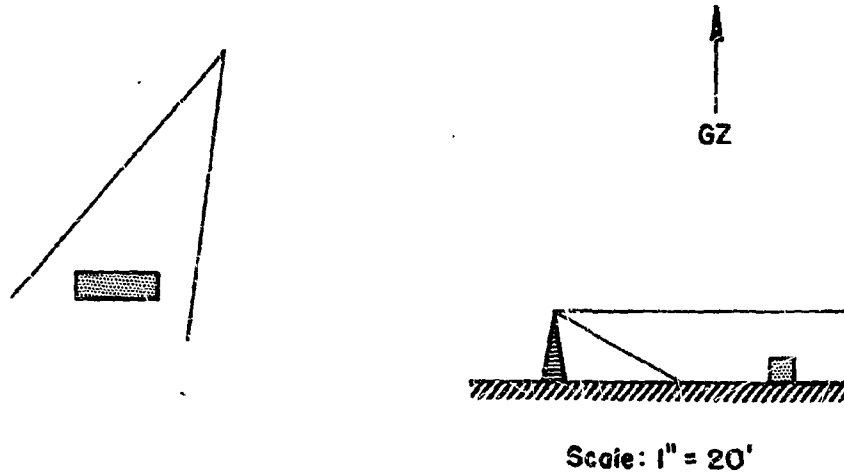

Project CETG-1

Camera:	GSAP	Distance to GZ:	2938'
F <sub>r</sub> /Sec:	60	Vertical Angle:	-10.0°
Lens:	18mm	EG&G Station No:	9.9d
Film:	MF	Film Number:	16757
Tower:	11' 3"		16758

Project CETG-2

Camera:	GSAP	Distance to GZ:	2938'
F <sub>r</sub> /Sec:	61	Vertical Angle:	-15.0°
Lens:	18mm	EG&G Station No:	9.9b
Film:	MF	Film Number:	16759
Tower:	18' 9"		16760

Fig. C.17 CETG Passenger Vehicle Studies

**UNCLASSIFIED**

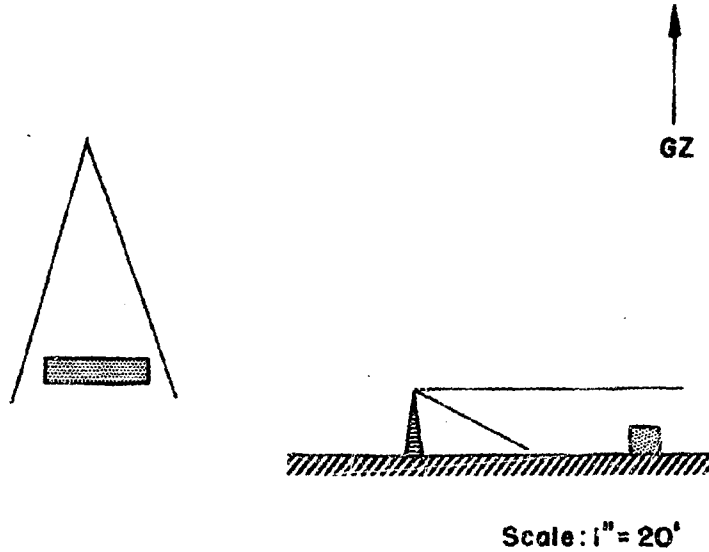

Project GETG-3

Camera: GSAP  
 Fr/Sec: 64  
 Lens: 18mm  
 Film: MF  
 Tower: 18' 9"

Distance to GZ: 2937'  
 Vertical Angle: -13.0°  
 EG&G Station No: 9.9a  
 Film Number: 16761  
 16762

Project GETG-4

Camera: GSAP  
 Fr/Sec: 62  
 Lens: 18mm  
 Film: MF  
 Tower: 18' 9"

Distance to GZ: 2937'  
 Vertical Angle: -13.0°  
 EG&G Station No: 9.9c  
 Film Number: 16763  
 16764

Fig. C.18 GETG Commercial Vehicle Studies

**UNCLASSIFIED**

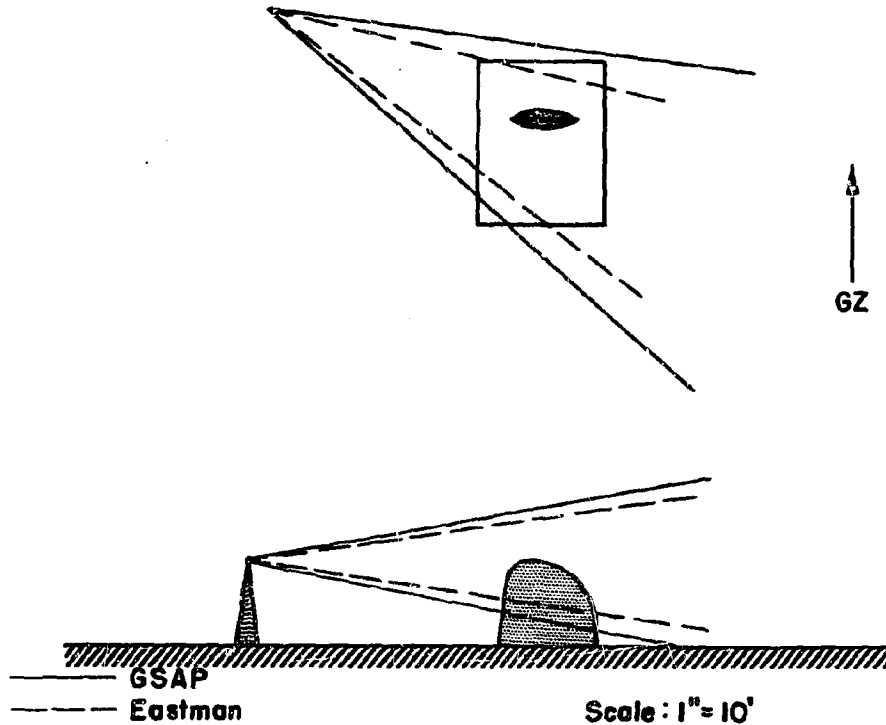

Project 8.1B-1

Camera:	GSAP	Eastman	Distance to GZ:	6540'
F <sub>r</sub> /Sec:	62	519	Vertical Angle:	0°
Lens:	18mm	25mm	EC&G Station No:	9.11f
Film:	KC	EX	Film Number:	16771
Tower:	6' 3"	6' 3"		16772

Project 8.1B-3

Camera:	GSAP	Eastman	Distance to GZ:	6540'
F <sub>r</sub> /Sec:	61	595	Vertical Angle:	0°
Lens:	18mm	25mm	EC&G Station No:	9.11h
Film:	KC	EX	Film Number:	16773
Tower:	6' 3"	6' 3"		16774

Fig. C.19 USAF Aircraft Component Studies

**UNCLASSIFIED**



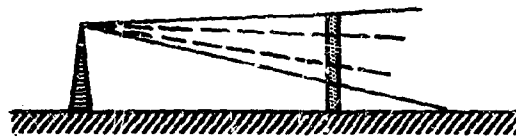
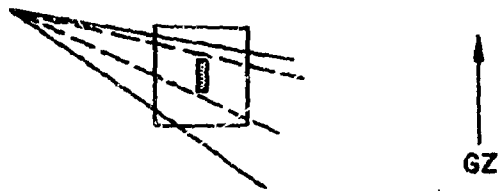

——— GSAP  
 - - - Eastman

Scale: 1" = 10'

Project 8.1B-2

Camera:	GSAP	Eastman	Distance to GZ:	6540'
Fx/Sec:	63	602	Vertical Angle:	-11.0°
Lens:	18mm	25mm	EG&G Station No:	9.11g
Film:	KC	BX	Film Number:	16771
Tower:	6' 3"	6' 3"		16772

Fig. C.20 USAF Aircraft Component Studies

**UNCLASSIFIED**

~~CONFIDENTIAL~~

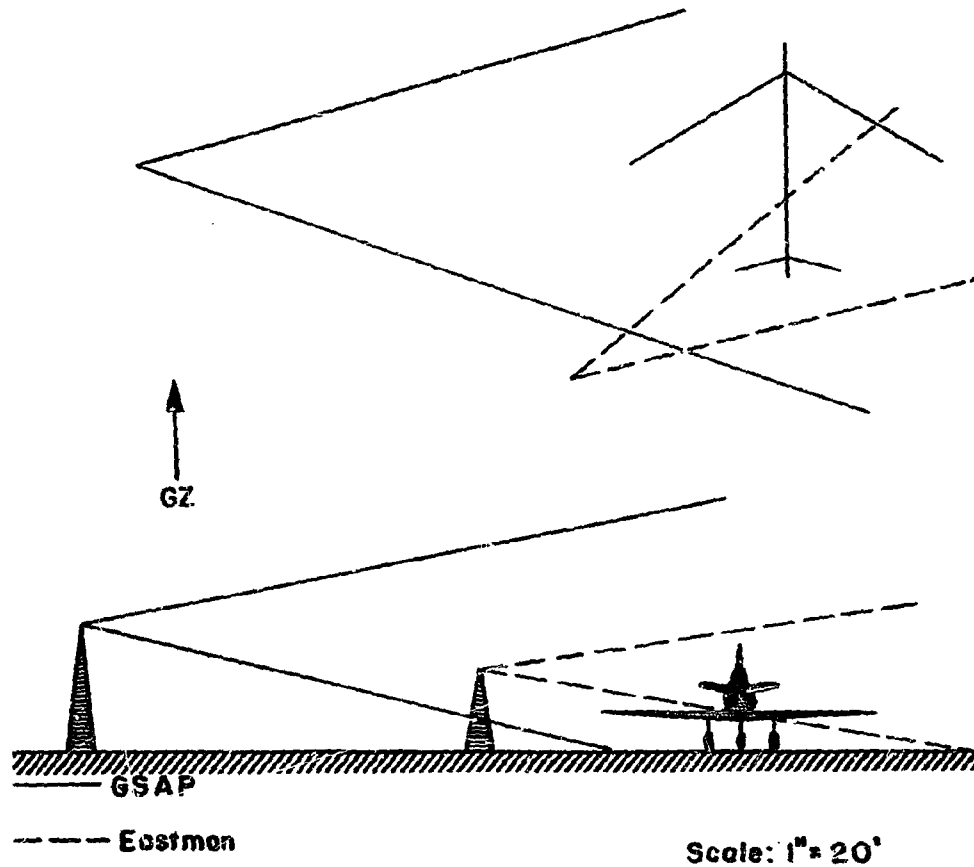

Project 8.11

Camera:	GSAP	Eastman	Distance to GZ:	6540'
Fr/Sec:	64	448	Vertical Angle:	-8°/-9°
Lens:	18mm	25mm	EG&G Station No:	9.11a/b
Film:	MF	MF	Film Number:	16765
Tower:	18' 9"	11' Pier		16797
				16766

Fig. C.21 USAF Aircraft Studies

**UNCLASSIFIED**

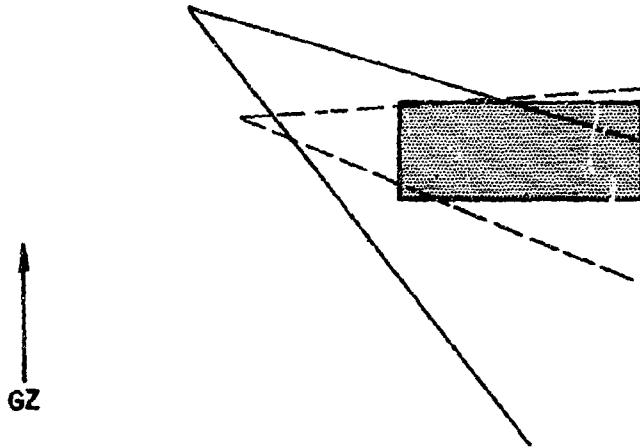

—— GSAP  
 - - - Eastman

Scale: 1" = 20'

Project 8.1M

Camera:	GSAP	Eastman	Distance to GZ:	5358'
Fr/Sec:	61	519	Vertical Angle:	-15°/0°
Lens:	12mm	25mm	EC&G Station No:	9.110/e
Film:	KC	HX	Film Number:	16798
Tower:	18' 9"	6' Pier		16767
				16768

Fig. C.22 USAF Aircraft Studies

UNCLASSIFIED

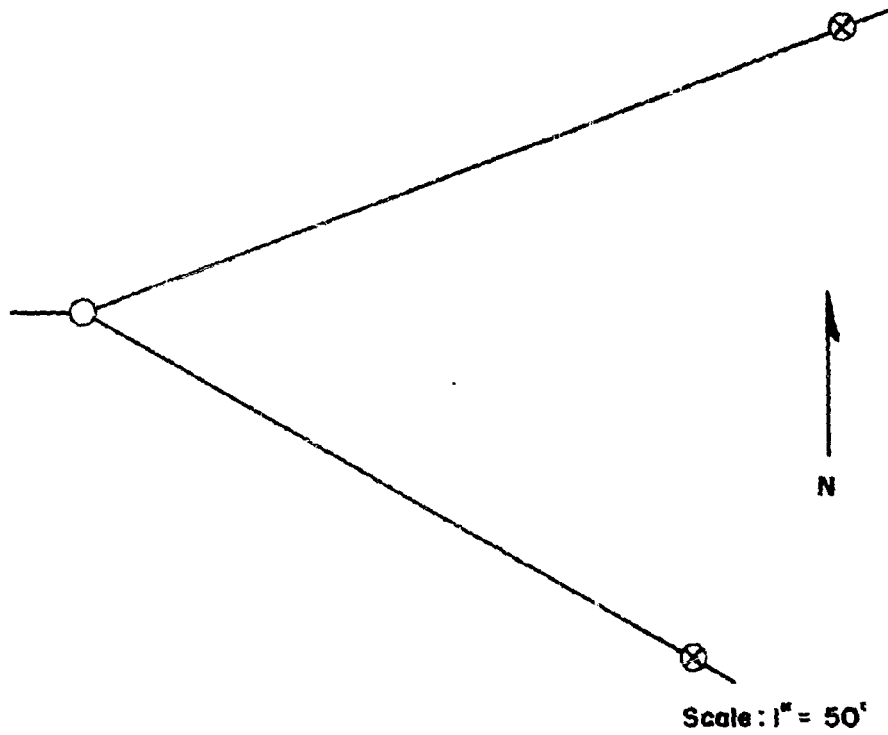

Project 8.4a

Camera:	Robot	Distance to GZ:	2568'
Fr/Min:	2	Vertical Angle:	Vertical
Lens:	40mm	EMG Station No:	9.12a
Film:	MF	Film Number:	16775
Tower:	Special		

Project 8.4b

Camera:	Robot	Distance to GZ:	2166'
Fr/Min:	2	Vertical Angle:	Vertical
Lens:	40mm	EMG Station No:	9.12c
Film:	MF	Film Number:	16776
Tower:	Special		

Fig. C.23 Chemical Corps Smokes Studies

**UNCLASSIFIED**

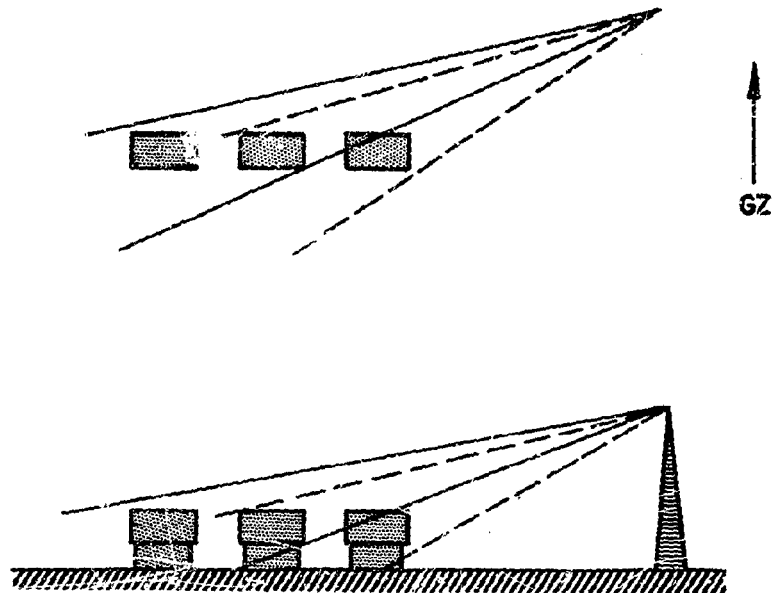

Project 8.5a

Scale: 1" = 10'

Camera: GSAP  
 Fr/Soc: 63  
 Lens: 4.0mm/4.0mm  
 Film: KC  
 Tower: 11' 3"

Distance to GZ: 5870'  
 Vertical Angle: -15.0°  
 EG&G Station No: 9.13a  
 Film Number: 16781  
 16782

Project 8.5c

Camera: GSAP  
 Fr/Soc: 60  
 Lens: 4.0mm/4.0mm  
 Film: KC  
 Tower: 11' 3"

Distance to GZ: 4870'  
 Vertical Angle: -13.0°  
 EG&G Station No: 9.13c  
 Film Number: 16779  
 16780

Project 8.5d

Camera: GSAP  
 Fr/Soc: 64  
 Lens: 4.0mm/4.0mm  
 Film: MF  
 Tower: 11' 3"

Distance to GZ: 3170'  
 Vertical Angle: -13.0°  
 EG&G Station No: 9.13d  
 Film Number: 16777  
 16778

Fig. C.24 U. S. Army QMC Thermal Studies

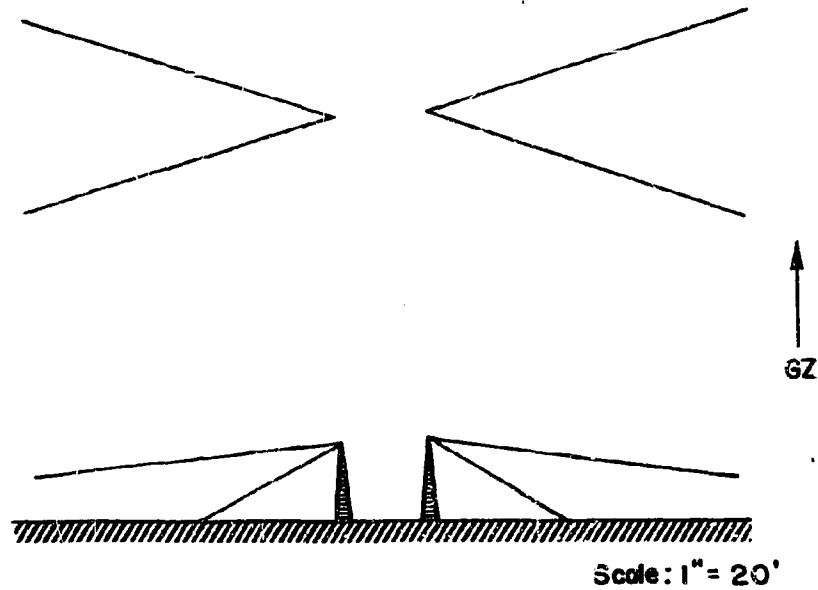

Project 9.7a & b

Camera:	GSAP	Distance to GZ:	1337'
F <sub>r</sub> /Sec:	-	Vertical Angle:	-22.0°
Lens:	18mm	EG&G Station No:	9.17a/b
Film:	MF	Film Number:	16789
Tower:	11' 3"		16790
			16791
			16792

Project 9.7c & d

Camera:	GSAP	Distance to GZ:	2850'
F <sub>r</sub> /Sec:	64	Vertical Angle:	-22.0°
Lens:	18mm	EG&G Station No:	9.17c/d
Film:	MF	Film Number:	16793
Tower:	11' 3"		16794
			16795
			16796

Fig. C.25 AFSWP Stabilization Studies

## APPENDIX D

### STILL PHOTOGRAPHY

#### D.1 GENERAL

The still photography portion of Project 9.1 is set forth in this appendix as it is believed this information will be useful for planning future operations of this type. The still photography for this operation was performed to provide technical data to the various projects, and photography of a non-technical nature. Included in this appendix is motion picture photography taken other than at zero time. Photography of purely historical interest was performed by the Lookout Mountain Laboratory and is not included in this appendix.

#### D.2 OBJECTIVE

The objective of the still photographic group was to provide before and after shots of the various weapons effects tests experiments in order that certain technical data might be recorded for later use in analyzing damage effects. In addition this photography furnished the various projects with documentary records for their reports. This group exposed motion picture footage for the projects where still photography would not suffice.

#### D.3 ORGANIZATION

The U. S. Army Signal Corps, Signal Corps Pictorial Center (SCPC) and the U. S. Air Force furnished trained personnel to conduct this phase of Project 9.1. All of the photographic equipment was furnished by the SCPC. This group was organized into several sections, namely, administration, still photography, motion picture photography and processing; however, most of the personnel were so trained that anyone could work equally well in any of the various sections. The SCPC furnished 23 officers and enlisted men and the USAF furnished five enlisted men to implement this project.

#### D.4 DETERMINATION OF REQUIREMENTS

The various project officers submitted their photographic requirements directly to the program director approximately 12

months in advance of the target date, and by the monthly status reports these requirements were kept current. The program director went over these requirements with the project officers and then in turn submitted the requirements to the SCPC for the determination of the number of personnel and equipments needed to conduct this phase of the operation. From past experience the project requirements were increased by the program director by a factor of 2 and this figure was quite realistic once operations in the field had begun.

#### D.5 SUMMARY OF STILL PHOTOGRAPHIC COVERAGE

A total of 86,500 4 x 5 still prints were made from approximately 11,000 negatives exposed for the various projects. All of these negatives and prints were processed at the test site in two transportable field processing laboratories (AN/TFG) designed by the U. S. Army Signal Corps. When it is considered that the AN/TFG was designed for field use to support an army unit in the field and not for an operation of this magnitude, only then can the efforts of the photographic personnel be fully realized and appreciated.

Throughout the entire operation approximately 15,000 feet of non-technical documentary motion picture film were exposed for the projects. Of this footage approximately 10,000 feet were color and 5,000 feet were black and white. These films were processed by the SCPC in New York City and/or the Eastman Kodak Co. in Hollywood, Calif. Six duplicate prints were made from all films, the original negative (or positive) being retained by the AFSWP and the prints distributed to the interested agencies.

In addition to the above coverage, approximately 3500 35 mm Kodachrome transparencies were exposed for the projects and these in turn were processed by the Eastman Kodak Co.

The entire project operated under the AEG photographic plan which outlines in detail the procedures for the control of light sensitive materials, classification of exposed light sensitive materials, the clearance of personnel and the internal security required for a photographic group.

#### D.6 RECOMMENDATIONS

It is recommended that on future operations of this nature:

1. One single service agency be responsible for all photography and that projects not be granted permission to have their own individual photographic units.

2. All photographers have a valid "Q" clearance before arriving at the Nevada Proving Grounds to preclude their idleness while awaiting the processing of a "Q" clearance.

3. A permanent photographic processing laboratory and film storage vault be constructed at the Nevada Proving Grounds. The cost incurred in moving the TFG's back and forth across the United States for several operations would more than justify the expenditure, and

**UNCLASSIFIED**



in addition a larger volume of work could be turned out with fewer personnel.

4. The Signal Corps Engineering Laboratories in conjunction with the PCPC and the Air Force, be asked to implement recommendation 4 above.

DISTRIBUTION

Copy

ARMY ACTIVITIES

Ast. Chief of Staff, G-3, D/A, Washington 25, D. C. ATTN: Dep. CofS, G-3 (RR&SW)	1
Ast. Chief of Staff, G-4, D/A, Washington 25, D. C.	2
Chief of Ordnance, D/A, Washington 25, D. C. ATTN: ORDTX-AR	3
Chief Signal Officer, D/A, P&O Division, Washington 25, D. C. ATTN: SIGOP	4 - 6
The Surgeon General, D/A, Washington 25, D. C. ATTN: Chairman, Medical R&D Board	7
Chief Chemical Officer, D/A, Washington 25, D. C.	8 - 9
The Quartermaster General, CBR, Liaison Officer, Research and Development Division, D/A, Washington 25, D. C.	10
Chief of Engineers, D/A, Washington 25, D. C. ATTN: ENGNB	11 - 14
Chief of Transportation, Military Planning and Intelligence Division, Washington 25, D. C.	15
Chief, Army Field Forces, Ft. Monroe, Va.	16 - 17
President, Board #1, OCAFF, Ft. Bragg, N. C.	18
President, Board #4, OCAFF, Ft. Bliss, Tex.	19
Commanding General, U. S. Army Caribbean, Ft. Amador, C. Z. ATTN: Cml. Off.	20
Commander-in-Chief, Far East Command, APO 500, c/o FM, San Francisco, Calif. ATTN: ACofS, J-3	21 - 22
Commanding General, U. S. Army Europe, APO 103, c/o FM, New York, N. Y. ATTN: OPOT Division, Combat Dev. Br.	23 - 24
Commandant, Command and General Staff College, Ft. Leavenworth, Kan. ATTN: ALLS(AS)	25
Commandant, The Artillery School, Ft. Sill, Okla.	26
Commanding General, Medical Field Service School, Brooke Army Medical Center, Ft. Sam Houston, Tex.	27
Director, Special Weapons Development Office, Ft. Bliss, Tex. ATTN: Lt. Arthur Jaskierny	28
Superintendent, U. S. Military Academy, West Point, N. Y. ATTN: Professor of Ordnance	29
Commanding General, Research and Engineering Command, Army Chemical Center, Md. ATTN: Deputy for RW and Non-Toxic Material	30
RD Control Officer, Aberdeen Proving Grounds, Md. ATTN: Dir., Ballistics Research Laboratory	31 - 32
Commanding General, The Engineer Center, Ft. Belvoir, Va. ATTN: Asst. Commandant, Engineer School	33 - 35
Commanding Officer, Engineer Research and Development Laboratory, Ft. Belvoir, Va. ATTN: Chief, Technical Intelligence Branch	36

**UNCLASSIFIED**

	Copy
Commanding Officer, Picatinny Arsenal, Dover, N. J. ATTN: GROBB-TK	37
Commanding Officer, Frankford Arsenal, Philadelphia 37, Pa. ATTN: RD Control Off.	38
Commanding Officer, Army Medical Research Laboratory, Ft. Knox, Ky.	39
Commanding Officer, Chemical Corps Chemical and Radiological Laboratory, Army Chemical Center, Md. ATTN: Tech. Library	40 - 41
Commanding Officer, Transportation R&D Station, Ft. Eustis, Va.	42
Director, Technical Documents Center, Evans Signal Laboratory, Belmar, N. J.	43
Director, Operations Research Office, Johns Hopkins University, 6410 Connecticut Ave., Chevy Chase, Md. ATTN: Library	44
 <b>NAVY ACTIVITIES</b>	
Chief of Naval Operations, D/N, Washington 25, D. C. ATTN: OP-36	45 - 46
Chief, Bureau of Medicine and Surgery, D/N, Washington 25, D. C. ATTN: Special Weapons Defense Division	47
Chief, Bureau of Ships, D/N, Washington 25, D. C. ATTN: Code 348	48
Chief, Bureau of Supplies and Accounts, D/N, Washington 25, D. C.	49
Chief, Bureau of Aeronautics, D/N, Washington 25, D. C.	50 - 51
Commander-in-Chief, U. S. Pacific Fleet, Fleet Post Office, San Francisco, Calif.	52
Commander-in-Chief, U. S. Atlantic Fleet, U. S. Naval Base, Norfolk 11, Va.	53
Commandant, U. S. Marine Corps, Washington 25, D. C. ATTN: AO3H	54
Superintendent, U. S. Naval Postgraduate School, Monterey, Calif.	55
Commanding Officer, U. S. Naval Schools Command, U. S. Naval Station, Treasure Island, San Francisco, Calif.	56
Commanding Officer, U. S. Fleet Training Center, Naval Base, Norfolk 11, Va. ATTN: Special Weapons School	57
Commanding Officer, U. S. Fleet Training Center, Naval Station, San Diego 36, Calif. ATTN: (SPWP School)	58
Commanding Officer, U. S. Naval Damage Control Training Center, Naval Base, Philadelphia 12, Pa. ATTN: ABC Defense Course	59
Commanding Officer, U. S. Naval Unit, Chemical Corps School, Army Chemical Training Center, Ft. McClellan, Ala.	60
Commander, U. S. Naval Ordnance Laboratory, Silver Spring 19, Md. ATTN: EH	61
Officer-in-Charge, U. S. Naval Civil Engineering Research and Evaluation Laboratory, U. S. Naval Construction Battalion Center, Port Hueneme, Calif. ATTN: Code 753	62
Director, U. S. Naval Research Laboratory, Washington 25, D. C.	63

**UNCLASSIFIED**

	Copy
Commanding Officer and Director, U. S. Navy Electronics Laboratory, San Diego 52, Calif. ATTN: Code 4223	64
Commanding Officer, U. S. Naval Radiological Defense Laboratory, San Francisco 24, Calif. ATTN: Technical Information Division	65 - 66
Commanding Officer and Director, David W. Taylor Model Basin, Washington 7, D. C. ATTN: Library	67
Commanding Officer, U. S. Naval Photographic Center, Anacostia, D. C.	68 - 69
Commander, U. S. Naval Air Development Center, Johnsville, Pa.	70
Director, Office of Naval Research Branch Office, 1000 Geary Street, San Francisco, Calif.	71 - 72

#### AIR FORCE ACTIVITIES

Asst. for Atomic Energy, Headquarters, USAF, Washington 25, D. C. ATTN: DCS/O	73
Director of Operations, Headquarters, USAF, Washington 25, D. C. ATTN: Operations Analysis	74
Director of Research and Development, Headquarters, USAF, Washington 25, D. C. ATTN: Combat Components Div.	75
Director of Intelligence, Headquarters, USAF, Washington 25, D. C. ATTN: AFOIN 1B2	76 - 77
The Surgeon General, Headquarters, USAF, Washington 25, D. C. ATTN: Bio. Def. Br., Pre. Med. Div.	78
Commander, Strategic Air Command, Offutt AFB, Omaha, Neb. ATTN: Operations Analysis	79
Commander, Tactical Air Command, Langley AFB, Va. ATTN: Documents Security Branch	80
Commander, Air Defense Command, Ent AFB, Colo.	81
Commander, Air Training Command, Scott AFB, Belleville, Ill. ATTN: DCS/O GTP	82
Commander, Air Research and Development Command, PO Box 1395, Baltimore, Md. ATTN: RDDN	83
Commander, Air Proving Ground Command, Eglin AFB, Fla. ATTN: AG/TRB	84
Commander, Air University, Maxwell AFB, Ala.	85 - 86
Commander, Flying Training Air Force, Waco, Tex. ATTN: Director of Observer Training	87 - 94
Commander, Crew Training Air Force, Randolph Field, Tex. ATTN: 2GTS, DCS/O	95
Commander, Headquarters, Technical Training Air Force, Gulfport, Miss. ATTN: TA&D	96
Commandant, Air Force School of Aviation Medicine, Randolph AFB, Tex.	97 - 98
Commander, Wright Air Development Center, Wright-Patterson AFB, Dayton, O. ATTN: WCOESP	99 - 100
Commander, Air Force Cambridge Research Center, 230 Albany Street, Cambridge 39, Mass. ATTN: Atomic Warfare Directorate	101

~~CONFIDENTIAL~~  
**UNCLASSIFIED**

**UNCLASSIFIED**

**UNCLASSIFIED**



Commander, Air Force Cambridge Research Center, 250 Albany Street, Cambridge 39, Mass. ATTN: CRHK, Geophysics Research Directorate	Copy 102
Commander, Air Force Special Weapons Center, Kirtland AFB, N. Mex. ATTN: Library	103 - 105
Commandant, USAF Institute of Technology, Wright-Patterson AFB, Dayton, O. ATTN: Resident College	106
Commander, Lowry AFB, Denver, Colo. ATTN: Department of Armament Training	107
Commander, 1009th Special Weapons Squadron, Headquarters, USAF, Washington 25, D. C.	108
The RAND Corporation, 1700 Main Street, Santa Monica, Calif. ATTN: Nuclear Energy Division	109 - 110

**OTHER DEPARTMENT OF DEFENSE ACTIVITIES**

Asst. Secretary of Defense, Research and Development, D/D, Washington 25, D. C.	111
U. S. National Military Representative, Headquarters, SHAPE, APO 55, c/o PM, New York, N. Y. ATTN: Col. J. P. Healy	112
Commandant, Armed Forces Staff College, Norfolk 11, Va. ATTN: Secretary	113
Commanding General, Field Command, Armed Forces Special Weapons Project, PO Box 5100, Albuquerque, N. Mex.	114 - 119
Chief, Armed Forces Special Weapons Project, PO Box 2610, Washington 13, D. C.	120 - 128
Office of The Technical Director, Directorate of Effects Tests, Field Command, AFSWP, PO Box 577, Menlo Park, Calif. ATTN: Dr. E. B. Doll	129

**ATOMIC ENERGY COMMISSION ACTIVITIES**

Edgerton, Germeshausen and Grier, 160 Brookline Ave., Boston 15, Mass. ATTN: Mr. Herbert B. Grier	130 - 131
Edgerton, Germeshausen and Grier, 1622 South A Street, Las Vegas, Nev. ATTN: Mr. Robert B. Patten	132 - 133
U. S. Atomic Energy Commission, Classified Technical Library, 1901 Constitution Ave., Washington 25, D. C. ATTN: Mrs. J. M. O'Leary (For DMA)	134 - 136
Los Alamos Scientific Laboratory, Report Library, PO Box 1663, Los Alamos, N. Mex. ATTN: Helen Rodman	137 - 139
Sandia Corporation, Classified Document Division, Sandia Base, Albuquerque, N. Mex. ATTN: Martin Lucero	140 - 141
University of California Radiation Laboratory, PO Box 808, Livermore, Calif. ATTN: Margaret Folden	142 - 143
Weapon Data Section, Technical Information Service, Oak Ridge, Tenn.	144
Technical Information Service, Oak Ridge, Tenn. (Surplus)	145 - 180



**UNCLASSIFIED**