

UNCLASSIFIED

AD NUMBER
ADB264750
NEW LIMITATION CHANGE
TO Approved for public release, distribution unlimited
FROM Distribution authorized to U.S. Gov't. agencies only; Proprietary Information; Sep 2000. Other requests shall be referred to U.S. Army Medical Research and Materiel Command, 504 Scott Street, Fort Detrick, MD 21702-5012.
AUTHORITY
USAMRMC ltr, dtd 28 July 2003

THIS PAGE IS UNCLASSIFIED

AD _____

Award Number: DAMD17-99-1-9460

TITLE: Mechanisms and Components of the DNA Damage Checkpoint

PRINCIPAL INVESTIGATOR: Marc F. Schwartz
Dr. David Stern

CONTRACTING ORGANIZATION: Yale University
New Haven, Connecticut 06510

REPORT DATE: September 2000

TYPE OF REPORT: Annual Summary

PREPARED FOR: U.S. Army Medical Research and Materiel Command
Fort Detrick, Maryland 21702-5012

DISTRIBUTION STATEMENT:

DISTRIBUTION STATEMENT B
Distribution authorized to
U. S. Govt. Agencies Only
Other requests shall be referred to:

PROPRIETARY
INFORMATION;
Sep 2000,

The views, opinions and/or findings contained in this report are those of the author(s) and should not be construed as an official Department of the Army position, policy or decision unless so designated by other documentation.

20010330 084

REPORT DOCUMENTATION PAGE

Form Approved
OMB No. 074-0188

Public reporting burden for this collection of information is estimated to average 1 hour per response, including the time for reviewing instructions, searching existing data sources, gathering and maintaining the data needed, and completing and reviewing this collection of information. Send comments regarding this burden estimate or any other aspect of this collection of information, including suggestions for reducing this burden to Washington Headquarters Services, Directorate for Information Operations and Reports, 1215 Jefferson Davis Highway, Suite 1204, Arlington, VA 22202-4302, and to the Office of Management and Budget, Paperwork Reduction Project (0704-0188), Washington, DC 20503

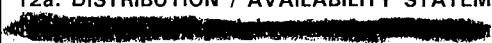
1. AGENCY USE ONLY (Leave blank)		2. REPORT DATE September 2000	3. REPORT TYPE AND DATES COVERED Annual Summary (1 Sep 99 - 31 Aug 00)	
4. TITLE AND SUBTITLE Mechanisms and Components of the DNA Damage Checkpoint			5. FUNDING NUMBERS DAMD17-99-1-9460	
6. AUTHOR(S) Marc F. Schwartz Dr. David Stern				
7. PERFORMING ORGANIZATION NAME(S) AND ADDRESS(ES) Yale University New Haven, Connecticut 06510 E-MAIL: marc.f.schwartz@yale.edu			8. PERFORMING ORGANIZATION REPORT NUMBER	
9. SPONSORING / MONITORING AGENCY NAME(S) AND ADDRESS(ES) U.S. Army Medical Research and Materiel Command Fort Detrick, Maryland 21702-5012			10. SPONSORING / MONITORING AGENCY REPORT NUMBER	
11. SUPPLEMENTARY NOTES				
12a. DISTRIBUTION / AVAILABILITY STATEMENT  DISTRIBUTION STATEMENT B Distribution authorized to U. S. Govt. Agencies Only Other requests shall be referred to:			12b. DISTRIBUTION CODE	
13. ABSTRACT (Maximum 200 Words) The DNA damage checkpoint (DDC), controls the cellular response to DNA damage. Loss of function of components of the mammalian DDC, such as ATM, hChk2, p53, and BRCA1, correlates with increased cancer risk. Eukaryotic DDC mechanisms are conserved; in <i>Saccharomyces cerevisiae</i> , ATM-family kinase Mec1 is required for the DDC, as are Rad53 and Rad9. Rad53 is the founding member of a kinase family implicated in DDCs, including mammalian homolog hChk2. Rad9 shares homology with the BRCA1 C-terminus. <i>S. cerevisiae</i> thus provides a powerful genetic system in which to study the conserved DDC mechanisms. The Mec1-dependent phosphorylation of Rad53 correlates with the propagation of the DDC signal. Mec1 is also required for the DDC-dependent phosphorylation of Rad9, leading to the binding of Rad53 to phospho-Rad9 via the second FHA domain within Rad53. A goal of this work is to characterize physical and catalytic interactions between Mec1, Rad53, and Rad9. As reported herein, we identified sites within Rad9 required for both the phosphorylation of Rad9 and for interaction with Rad53. These sites are putative Mec1 substrates. We cloned, tagged, and expressed Mec1, and demonstrated that it phosphorylates Rad9 <i>in vitro</i> . Further, <i>in vitro</i> Rad53 FHA2 binds this Rad9 phosphopeptide.				
14. SUBJECT TERMS DNA Damage Checkpoint, <i>MEC1</i> , <i>RAD53</i> , <i>RAD9</i> , FHA domain			15. NUMBER OF PAGES 15	
			16. PRICE CODE	
17. SECURITY CLASSIFICATION OF REPORT Unclassified	18. SECURITY CLASSIFICATION OF THIS PAGE Unclassified	19. SECURITY CLASSIFICATION OF ABSTRACT Unclassified	20. LIMITATION OF ABSTRACT Unlimited	

PROPRIETARY INFORMATION; Sep 2000.

Table of Contents

Cover.....	1
SF 298.....	2
Table of Contents.....	3
Introduction.....	4
Body.....	4
Key Research Accomplishments.....	7
Reportable Outcomes.....	7
Conclusions.....	8
References.....	8
Appendices (Figures).....	10
Appendices (Reportable Outcomes – Abstracts).....	14

Introduction

Survival of genotoxic shock is essential to the survival of any organism. The DNA damage checkpoint (DDC) controls the cellular response to DNA damage (10, 19, 23, 24). Dysfunction of components of the mammalian DDC, such as ATM, hChk2, p53, and BRCA1, correlates with accelerated tumorigenesis, increased cancer risk, and tumor chemotherapeutic resistance (2, 8, 11, 18, 20, 21). Eukaryotic DDC mechanisms are conserved; in *Saccharomyces cerevisiae*, ATM-family kinase *MEC1* is required for the DDC, as are Rad53 and Rad9 (1, 5, 12, 14, 16, 19, 22, 25, 29, 30, 31). Rad53 is the founding member of a kinase family implicated in DDCs, including mammalian homolog hChk2 (3, 4, 12, 13, 15, 30). Rad9 shares homology with the BRCA1 C-terminus (32). *S. cerevisiae* thus provides a powerful genetic system in which to study the conserved DDC mechanisms.

The Mec1-dependent phosphorylation of Rad53 correlates with the propagation of the DDC signal (17, 26, 27). Mec1 is also required for the DDC-dependent phosphorylation of Rad9 (26, 7, 28), leading to the binding of Rad53 to phospho-Rad9 via the second FHA domain within Rad53 (26). The two objectives of this project are: to define the molecular and catalytic interaction between Mec1, Rad53, and Rad9 that lead to the activation of Rad53 by the DDC; and to identify and begin characterization of mammalian homologs of *RAD53*. The first objective is the larger of the two, and was scheduled to occupy most of my time for the first year of my funding.

Progress on Objective 1: Characterization of physical and catalytic interactions of Mec1

Task 1: identification and characterization of Mec1

To determine if Mec1 phosphorylates Rad9 or Rad53, the first goal was to obtain catalytically active Mec1. The first route to study of Mec1 activity was to generate bacterially expressed Mec1 kinase domain fusion proteins. A similar approach was previously employed for the study of the catalytic activity of ATM (2). The first step in generating Mec1 constructs was to clone *MEC1* from a wildtype yeast strain. I cloned *MEC1* from diploid yeast strain NY882 by recombination repair. The clone fully rescues the checkpoint deficiencies of a *mec1Δ* strain, suggesting that the clone is fully functional. A bacterial GST-kinase domain fusion was constructed and expressed in protease deficient bacteria. While the fusion protein expressed well, and was easily purified (Fig. 1), the construct lacked detectable kinase activity as measured by either autophosphorylation or phosphorylation of a test substrate. Similar truncated fusion proteins expressed in mammalian tissue culture cells also lacked activity, suggesting that the lack of activity is inherent to the construct and not the expression system.

Turning to *S. cerevisiae* as an expression system, I generated a full-length galactose-induced expression construct of Mec1 with an N-terminal V5 epitope tag. This construct also rescues the checkpoint defects of a *mec1Δ* strain, confirming that the epitope tag does not disrupt the function of the protein. Mec1 proved to be an unstable protein; Mec1 rapidly degrades when stored in the freezer. After repeated attempts, I succeeded in observing V5Mec1 in both cell lysates and immunoprecipitations (Fig. 2). V5Mec1 is also catalytically active, as measured by autophosphorylation and test substrate phosphorylation in an *in vitro* kinase assay (Fig. 2). Phosphorylation of test substrates revealed that in the proper context, Mec1 phosphorylates threonine. Other residues, such as serine or tyrosine, have not been ruled out. My studies of the catalytic activity of Mec1 are ongoing.

Task 2: determination of the physiological relevance of Mec1 activity

To confirm that Mec1 is the kinase that phosphorylates Rad53 and Rad9 in response to DNA damage, I plan to identify sites of *in vivo* phosphorylation and determine if Mec1 phosphorylates these residues *in vitro*. Using a Rad9 test substrate identified as described in the next section, I performed *in vitro* immune complex kinase assays with V5Mec1. V5Mec1 specifically phosphorylated a threonine residue in this construct, demonstrating that Mec1 indeed phosphorylates Rad9 *in vitro* (Fig. 2). As subsequent experiments on this site within Rad9 demonstrates that it is likely not *in vivo* a major site of Mec1 phosphorylation, my experiments on the *in vitro* specificity of Mec1 for Rad9 are ongoing.

To identify sites of *in vivo* phosphorylation on Rad9, I plan to use tryptic phosphopeptide mapping. This experiment requires the ability to obtain a significant amount of *in vivo* ^{32}P -labeled Rad9. Previously in our laboratory, Rad9 was detected and purified via a C-terminal FLAG epitope tag. Unfortunately, shortly before the initiation of these studies, the anti-FLAG antibody we used was discontinued. Altering our protocols to incorporate other anti-FLAG reagents proved intractable. Hence, I replaced the C-terminal FLAG tag on Rad9 with a triple HA epitope (3xHA). This epitope, like the FLAG epitope, does not compromise the function of Rad9.

I initiated pilot experiments to obtain *in vivo* labeled Rad9. Rad9-3xHA was successfully labeled and purified in amounts that will most likely prove sufficient for tryptic phosphopeptide mapping. However, this approach is technically daunting due to both the high (millicurie) amounts of radioactive orthophosphate utilized, and the potential technical difficulties. Therefore, this approach is currently delayed in favor of the more rapid and approachable method described below.

Task 3: identification of physical interactions between Mec1, Rad53, and Rad9

To characterize the formation of a complex including Mec1, Rad53, and Rad9, I am expanding our understanding of the Rad53-Rad9 interaction first discovered in our laboratory. As *MEC1* is required for the phosphorylation in response to DNA damage, and Rad53 FHA2 specifically binds the phosphorylated form of Rad9, it is likely that Mec1 creates a phospho-binding site for Rad53 FHA2 within Rad9. Two-hybrid analysis of Rad9 deletion constructs identified a 78 amino acid sequence within Rad9 (Rad9 MID – minimal interaction domain) sufficient for interaction with Rad53 FHA2. Supporting the hypothesis that Mec1 creates the binding site for Rad53, a putative ATM-family phosphorylation site (TQ#8) was observed within this sequence. Mutation of the threonine to alanine largely abrogated the two-hybrid interaction, and mutation to a positively charged arginine abolished the interaction. However, substitution of a negatively charged glutamate for the threonine, mimicking the negative charge of a phosphorylated threonine, largely rescued the two-hybrid interaction.

To confirm the identification of a Rad53 phospho-binding site within Rad9 *in vivo*, I generated Rad9-3xHA expression constructs containing both a threonine-to-alanine substitution at TQ#8, as well as a 28 amino acid deletion encompassing TQ#8. Surprisingly, these mutations failed to impair the Rad9 phosphorylation observed in response to DNA damage (Fig. 3). This suggests TQ#8 either is not a major phosphorylation site within Rad9, or phosphorylation of TQ#8 does not have a major effect on the electrophoretic mobility shift of Rad9. If Rad53 FHA2 binds Rad9 primarily at TQ#8, these mutations should prevent this interaction, detaching Rad53 from DDC regulation. However, these mutations fail to both alter the activation of Rad53 (Fig. 3), and disrupt the normal action of the G_2 DDC to prevent mitosis after DNA damage. These data suggest TQ#8 is either redundant with other Rad53 binding sites, or was a false positive identified in the potentially artificial environment of the two-hybrid system.

To identify other putative Mec1 phosphorylation sites that contribute to the interaction of Rad53 with Rad9, I constructed a set of strains containing combinations of mutations these residues. To eliminate the possibility of redundant contribution of TQ#8, these mutations were generated in Rad9 already containing the 28 amino acid deletion surrounding TQ#8. Of the 13 putative Mec1 phosphorylation sites within Rad9 additional to TQ#8, I screened through mutations in 9 of these (Fig. 4). While most had no effect, deletion of 69 amino acids containing a cluster of six of these sites both abrogated the DNA damage induced phosphorylation of Rad9, and impaired the interaction of Rad53 with Rad9 (Fig. 5).

To confirm that the disruptions in Rad53/Rad9 behavior observed are due to the loss of the phosphorylation sites, and not due to a nonspecific disruption of Rad9 from the deletion, I generated a mutant with alanine substitutions at the six putative phosphorylated residues ($\text{rad9}^{6\text{xA}}$). Like the cluster deletion, this six-alanine mutation (6xA) impairs both the DNA damage dependent phosphorylation of Rad9, and its subsequent interaction with Rad53 (Fig. 6). These data suggest that this cluster represents a *bona fide* binding site for Rad53. Building on the 6xA mutation, I alanine-substituted TQ#8 ($\text{rad9}^{7\text{xA}}$). $\text{rad9}^{7\text{xA}}$ biochemically appears

similar to the $rad9^{6xA}$, suggesting that TQ#8 does not significantly contribute to the interaction of Rad53 with Rad9.

To determine if the 6xA mutation within Rad9 impairs the function of the DDC, I analyzed the ability of these mutants cells to prevent mitosis in the face of a strong DNA damage signal. In this assay, $rad53$ cells initiate arrest, but fail to maintain the G₂ arrest as single nucleated cells, instead proceeding with nuclear division to yield cells with two nuclei (26, 9). $rad9\Delta$ cells demonstrate a complete failure of the G₂ DDC, proceeding through nuclear division without pause (9). If the $rad9^{6xA}$ mutant fails to activate Rad53 due to a general defect in Rad9 function, then $rad9^{6xA}$ cells will behave similar to $rad9\Delta$. Alternatively, if $rad9^{6xA}$ is functionally deficient for Rad53 activation, as it is biochemically, then $rad9^{6xA}$ cells will behave similar to $rad53$ cells. My analysis of the G₂ DDC in wildtype, $rad9^{6xA}$, $rad9\Delta$, and $rad53^{FHA2-NVS}$ demonstrated that $rad9^{6xA}$ has defects similar to those of the $rad53$ cells (Fig. 7). I have generated an array of mutations in the six putative phosphorylation sites within the Rad9 cluster, and am currently evaluating their individual contribution to the Rad9/Rad53 interaction, and to the function of the G₂ DDC.

To identify interactions between checkpoint components via two-hybrid analysis, we generated several more constructs. Working with Damon Banks, a rotation student in the lab, we constructed three overlapping Mec1 constructs to screen for Mec1-interacting proteins. However, due to the potential for false interactions suggested by the two-hybrid deletion mapping of the Rad53-Rad9 interaction, we are delaying initiating a two-hybrid screen in favor of our current biochemical experiments.

Task 4: *in vitro* reconstruction of the Rad53-Rad9 interaction

One of the outstanding questions about the Rad53-Rad9 interaction is whether the interaction is direct, or via another polypeptide or other intermediary. To distinguish these possibilities, I seek to demonstrate Rad53 binding to Rad9 *in vitro* using components generated independently of *S. cerevisiae*. After identification of TQ#8 as a putative phospho-specific binding site for Rad53 FHA2, I had synthesized two versions of the 28 mer tryptic peptide containing TQ#8: a normal version, and a version with phosphothreonine at TQ#8. To demonstrate binding of Rad53 to this peptide, I developed the following assay: the synthetic Rad9 peptides were dot blotted to a membrane, and a soluble, bacterially expressed Rad53 FHA2 fusion protein was floated in. GST-Rad53 FHA2 binding was detected via chemiluminescence with antibodies to GST (Fig. 8). This experiment demonstrated that Rad53 FHA2 specifically binds the phosphorylated version of a Rad9 peptide. With my more recent identification of the Rad9 cluster as a binding site for Rad53 FHA2, I am currently repeating these experiments with peptides derived from the cluster. In the course of this work, Durocher *et al* (6) demonstrated *in vitro* phospho-specific binding of FHA domains to artificial substrates. Surprisingly, were also able to use a GST-Rad53 FHA1 fusion protein to precipitate Rad9-containing complexes from cell lysates. This was unexpected given our two-hybrid analysis that suggested that Rad53 FHA1 is not able to substitute for Rad53 FHA2 (26, unpub. data). This data suggest that Rad53 FHA1 may participate in the Rad53/Rad9 interaction; alternatively, Rad53 FHA1 may also be capable of interacting with other components of a Rad9-containing complex. I am currently also investigating the possibility of direct binding of Rad53 FHA1 to Rad9.

Progress on Objective 2: Identification of mammalian Rad53 homologs

Task 1: *initiation of screens for mammalian checkpoint homologs*

At the outset of this project, there were no known mammalian homologs of Rad53. To identify these genes, I planned a degenerate-PCR strategy to isolate homologs based on their sequence similarity in FHA and kinase domains. Working with Damon Banks, we designed and had synthesized a set of highly degenerate primers for both the FHA and kinase domains. We selected a λ -gt11 library constructed from growing Jurkat cells, lymphocytes we reasoned were likely to express DDC genes. We tested a range of PCR amplification parameters, including annealing and extension temperatures, primer and template concentration, and divalent cation content. In a pilot experiment, we amplified and cloned several products. Of eight isolates, in two the primers had amplified a genuine target sequence; one of the kinase domain primers successfully amplified a kinase. Surprisingly, both independently amplified kinase clones were Chk1, a known DDC component. While

the pilot experiment did not identify a novel checkpoint gene, this result suggested that this was a viable approach.

Unfortunately, shortly after the pilot experiments in developing the screen for mammalian homologs for Rad53, several laboratories published their independent isolation and characterization of Rad53 homologs (3, 4, 15). The identified gene, named Chk2, is a component of the mammalian ATM/ATR DDCs, validating the concept for this objective. However, between these and subsequent publications, much of the remaining experiments proposed for Objective 2 were reported. Therefore, based on the advice of my mentor, Dr. David Stern, and my thesis advisory committee, I am focusing my efforts on the development and expansion of the goals within the first objective. The work required to develop, as well as the results derived from my goals in Objective 1 are much more expansive than I originally anticipated. Indeed, the “overly ambitious” nature of my proposal was one of the few negative comments given by the proposal’s reviewers.

Key Research Accomplishments

- Cloned, expressed, and purified ATM-homolog Mec1
- Developed *in vitro* Mec1 kinase assay
- Identified Rad9 as a Mec1 substrate *in vitro*
- Identified putative Mec1 phosphorylation sites within Rad9 *in vivo* required for Rad53 interaction and function of the DNA damage checkpoint
- Reconstructed *in vitro* the binding of Rad53 FHA2 to a phosphorylated Rad9 peptide
- Initiated a degenerate-PCR screen for Rad53 homologs

Reportable Outcomes

1. Manuscripts, abstracts, and presentations

Schwartz, M.F., Sun, Z., Hsiao, J., and Stern, D.F. (2000) Phosphorylation-dependent Interaction of Rad53 with Rad9 in the DNA Damage Checkpoint of *S. cerevisiae*. 65th Cold Spring Harbor Laboratory Symposium, Biological Responses to DNA Damage.

Schwartz, M.F., Sun, Z., Hsiao, J., and Stern, D.F. (2000) Interaction of Rad53 with Rad9 in the DNA Damage Checkpoint of *S. cerevisiae*. Department of Defense Breast Cancer Research Program Era of Hope Meeting.

2. Patents and licenses applied for and/or issued
3. Degrees obtained
4. Development of cell lines, tissue or serum repositories
5. Informatics
6. Funding applied for
7. Employment or research opportunities applied for

Summary

Significant progress has been made in meeting the goals of the first objective of this proposal. I successfully developed Mec1 as a biochemical reagent, and am currently investigating the specificity and relevance of its *in vitro* activity. I identified putative Mec1 phosphorylation sites within Rad9 that are required for both the phosphorylation of Rad9 and the interaction of Rad53 FHA2 with Rad9 in response to DNA damage. I demonstrated that Mec1 can phosphorylate Rad9 *in vitro*, and that Rad53 FHA2 binds this site *in vitro* when phosphorylated. I will shortly be completing this series of experiments, and will prepare my first manuscript for submission before the end of the year.

References

1. Allen, J. B., Zhou, Z., Siede, W., Friedberg, E. C., and Elledge, S. J. (1994). The SAD1/RAD53 protein kinase controls multiple checkpoints and DNA damage-induced transcription in yeast. *Genes Dev.* 8, 2416-2428.
2. Baskaran, R., Wood, L. D., Whitaker, L. L., Canman, C. E., Morgan, S. E., Xu, Y., Barlow, C., Baltimore, D., Wynshaw-Boris, A., Kastan, M. B., and Wang, J. Y. J. (1997). Ataxia telangiectasia mutant protein activates c-Abl tyrosine kinase in response to ionizing radiation. *Nature* 387, 516-519.
3. Blasina, A., Weyer, de I. V., Laus, M. C., Luyten, W. H., Parker, A. E., and McGowan, C. H. (1999) A human homologue of the checkpoint kinase Cds1 directly inhibits Cdc25 phosphatase. *Curr. Biol.* 9, 1-10.
4. Brown, A. L., Lee, C. H., Schwarz, J. K., Mitiku, N., Piwnica-Worms, H., and Chung, J.H. (1999) A human Cds1-related kinase that functions downstream of ATM protein in the cellular response to DNA damage. *Proc. Natl. Acad. Sci.* 96, 3745-3750.
5. de la Torre-Ruiz, M. A., Green, C. M., and Lowndes, N. F. (1998). Rad9 and Rad24 define two additive, interacting branches of the DNA damage checkpoint pathway in budding yeast normally required for Rad53 modification and activation. *EMBO J.* 17, 2687-2698.
6. Durocher, D., Henckel, J., Fersht, A. R., and Jackson, S. P. (1999) The FHA domain is a modular phosphopeptide recognition motif. *Mol. Cell* 4, 387-394.
7. Emili, A., and Hartwell, L. H. (1998). MEC1-dependent phosphorylation of Rad9p in response to DNA damage. *Mol Cell* 2, 183-189.
8. Ford, D., Easton, D. F., Stratton, M., Narod, S., Goldgar, D., Devilee, P., Bishop, D. T., Weber, B., Lenoir, G., Changclaude, J., Sobol, H., Teare, M. D., Struewing, J., Arason, A., Scherneck, S., Peto, J., Rebbeck, T. R., Tonin, P., Neuhausen, S., Barkardottir, R., Eyfjord, J., Lynch, H., Ponder, B. A. J., Gayther, S. A., Birch, J. M., Lindblom, A., *et al.* (1998). Genetic heterogeneity and penetrance analysis of the *BRCA1* and *BRCA2* genes in breast cancer families. *Am. J. Hum. Genet.* 62, 676-689.
9. Gardner, R., Putnam, C.W., and Weinert, T. (1999) RAD53, DUN1 and PDS1 define two parallel G2/M checkpoint pathways in budding yeast. *EMBO J* 18, 3173-85.
10. Hartwell, L. H., and Weinert, T. A. (1989). Checkpoints: controls that ensure the order of cell cycle events. *Science* 246, 629-634.
11. Hawn, M. T., Umar, A., Carethers, J. M., Marra, G., Kunkel, T. A., Boland, C. R., and Koi, M. (1995). Evidence for a connection between the mismatch repair system and the G2 cell cycle checkpoint. *Cancer Res.* 55, 3721-3725.
12. Kato, R., and Ogawa, H. (1994). An essential gene, *ESR1*, is required for mitotic cell growth, DNA repair, and meiotic recombination in *Saccharomyces cerevisiae*. *Nucleic Acids Res.* 22, 3104-3112.
13. Kiser, G. L., and Weinert, T. A. (1996). Distinct roles of yeast *MEC* and *RAD* checkpoint genes in transcriptional induction after DNA damage and implications for function. *Mol. Biol. Cell* 7, 703-718.

14. Lydall, D., and Weinert, T. (1995). Yeast checkpoint genes in DNA damage processing: implications for repair and arrest. *Science* 270, 1488-1491.
15. Matsuoka, S., Huang, M., and Elledge, S. J. (1998) Linkage of ATM to cell cycle regulation by the Chk2 protein kinase. *Science* 282, 1893-1897.
16. Paulovich, A. G., Margulies, R. U., Garvik, B. M., and Hartwell, L. H. (1997). *RAD9*, *RAD17*, and *RAD24* are required for S phase regulation in *Saccharomyces cerevisiae* in response to DNA damage. *Genetics* 145, 45-62.
17. Sanchez, Y., Desany, B. A., Jones, W. J., Liu, Q., Wang, B., and Elledge, S. J. (1996). Regulation of *RAD53* by the *ATM*-like kinases *MEC1* and *TEL1* in yeast cell cycle checkpoint pathways. *Science* 271, 357-359.
18. Savitsky, K., Bar-Shira, A., Gilad, S., Rotman, G., Ziv, Y., Vanagaite, L., Tagle, D. A., Smith, S., Uziel, T., Sfez, S., Ashkenazi, M., Pecker, I., Frydman, M., Harnik, R., Patanjali, S. R., Simmons, A., Clines, G. A., Sartiel, A., Gatti, R. A., Chessa, L., Sanal, O., Lavin, M. F., Jaspers, N. G. J., Malcolm, A., Taylor, R., Arlett, C. F., Miki, T., Weissman, S. M., Lovett, M., Collins, F. S., and Shiloh, Y. (1995). A single ataxia telangiectasia gene with a product similar to PI-3 kinase. *Science* 268, 1749-1753.
19. Schiestl, R. H., Reynolds, P., Prakash, S., and Prakash, L. (1989). Cloning and sequence analysis of the *Saccharomyces cerevisiae* *RAD9* gene and further evidence that its product is required for cell cycle arrest induced by DNA damage. *Mol. Cell. Biol.* 9, 1882-1896.
20. Scully, R., Chen, J., Ochs, R. L., Keegan, K., Hoekstra, M., Feunteun, J., and Livingston, D. M. (1997). Dynamic changes of BRCA1 subnuclear location and phosphorylation state are initiated by DNA damage. *Cell* 90, 425-435.
21. Sherr, C. J. (1996). Cancer cell cycles. *Science* 274, 1672-1677.
22. Siede, W., Friedberg, A. S., Dianova, I., and Friedberg, E. C. (1994). Characterization of the G₁ checkpoint control in yeast *Saccharomyces cerevisiae* following exposure to DNA-damaging agents. *Genetics* 138, 271-281.
23. Siede, W., Friedberg, A. S., and Friedberg, E. C. (1993). *RAD9* dependent G₁ arrest defines a second checkpoint for damaged DNA in the cell cycle of *Saccharomyces cerevisiae*. *Proc.Natl.Acad.Sci.* 90, 7985-7989.
24. Slater, M. L. (1973). Effect of reversible inhibition of deoxyribonucleic acid synthesis on the yeast cell cycle. *J. Bacteriol.* 113, 263-270.
25. Stern, D. F., Zheng, P., Beidler, D. R., and Zerillo, C. (1991). Spk1, a new kinase from *S. cerevisiae*, phosphorylates proteins on serine, threonine, and tyrosine. *Mol. Cell. Biol.* 11, 987-1001.
26. Sun, Z., Hsiao, J., Fay, D. S., and Stern, D. F. (1998). Rad53 FHA domain associated with phosphorylated Rad9 in the DNA damage checkpoint. *Science* 281, 272-274.
27. Sun, Z., Fay, D. S., Marini, F., Foiani, M., and Stern, D. F. (1996). Spk1/Rad53 is regulated by Mec1-dependent protein phosphorylation in DNA replication and damage checkpoint pathways. *Genes & Dev.* 10, 395-406.
28. Vialard, J. E., Gilbert, C. S., Green, C. M., and Lowndes, N. F. (1998) The budding yeast Rad9 checkpoint protein is subjected to Mec1/Tel1-dependent hyperphosphorylation and interacts with Rad53 after DNA damage. *EMBO J.* 17, 5679-5688.
29. Weinert, T. A., and Hartwell, L. H. (1988). The *RAD9* gene controls the cell cycle response to DNA damage in *Saccharomyces cerevisiae*. *Science* 241, 317-322.
30. Weinert, T. A., Kiser, F. L., and Hartwell, L. H. (1994). Mitotic checkpoint genes in budding yeast and the dependence of mitosis on DNA replication and repair. *Genes Dev.* 8, 652-665.
31. Zhou, Z., and Elledge, S. J. (1993). *DUN1* encodes a protein kinase that controls the DNA damage response in yeast. *Cell* 75, 1119-1127.
32. Koonin, E. V., Altschul, S. F., and Bork, P. (1996). BRCA1 protein products: functional motifs. *Nature Genetics* 13, 266-268.

Figures

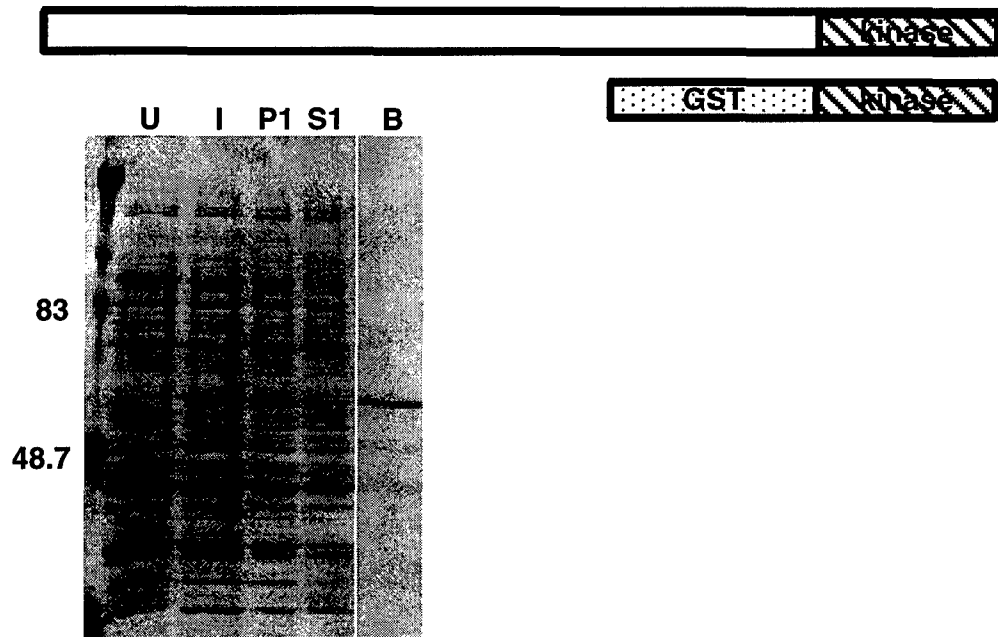

Figure 1: GST-Mec1 purification. Top: schematic of GST-Mec1 fusion construct, relative to full length Mec1. Bottom: coomassie stained gel showing purification of Mec1 GST fusion. U, uninduced whole cell extract; I, induced whole cell extract; P1, low speed pellet; S1, low speed supernatant; B, glutathione-agarose beads.

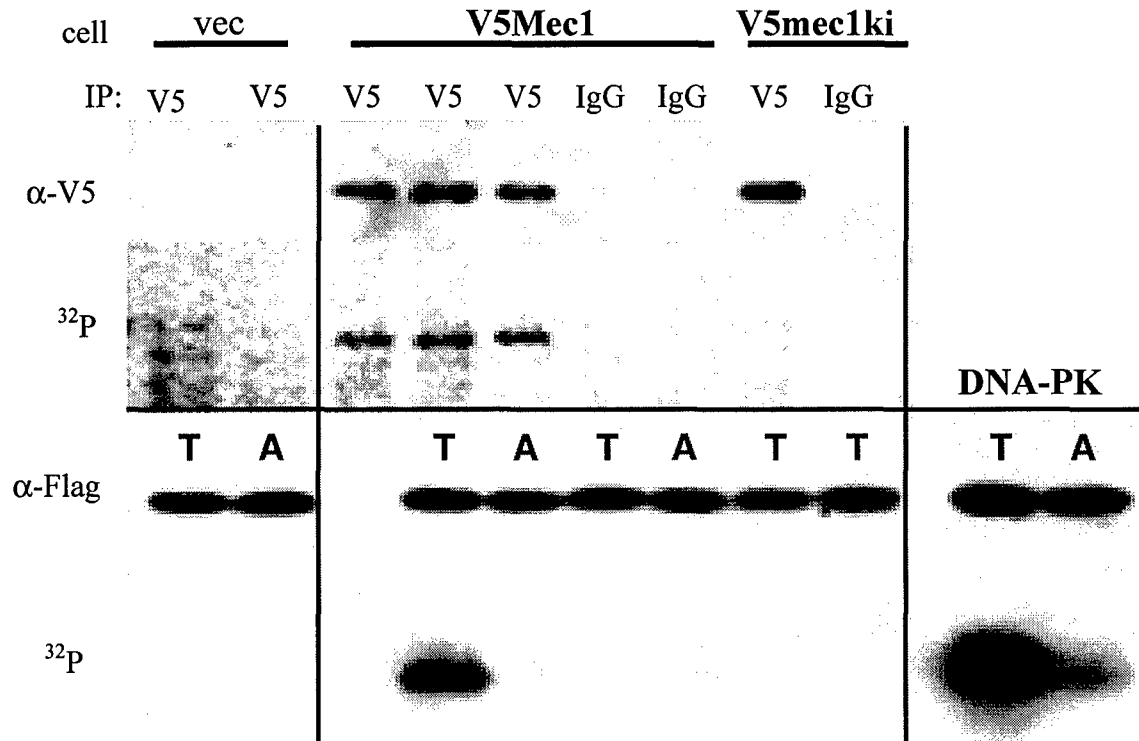

Figure 2: V5Mec1 immune complex kinase assay on Rad9 MID. Immunoprecipitated V5Mec1 demonstrates autocatalytic activity, and phosphorylates only wildtype Rad9 MID (lane 4). Immunoprecipitated kinase dead V5mec1 lacks both activities (lane 8). vec, lysates lacking Mec1; V5Mec1, lysates with V5Mec1; V5mec1ki, lysates with kinase dead V5mec1; T, wildtype Rad9 MID substrate; A, alanine substitution at TQ#8.

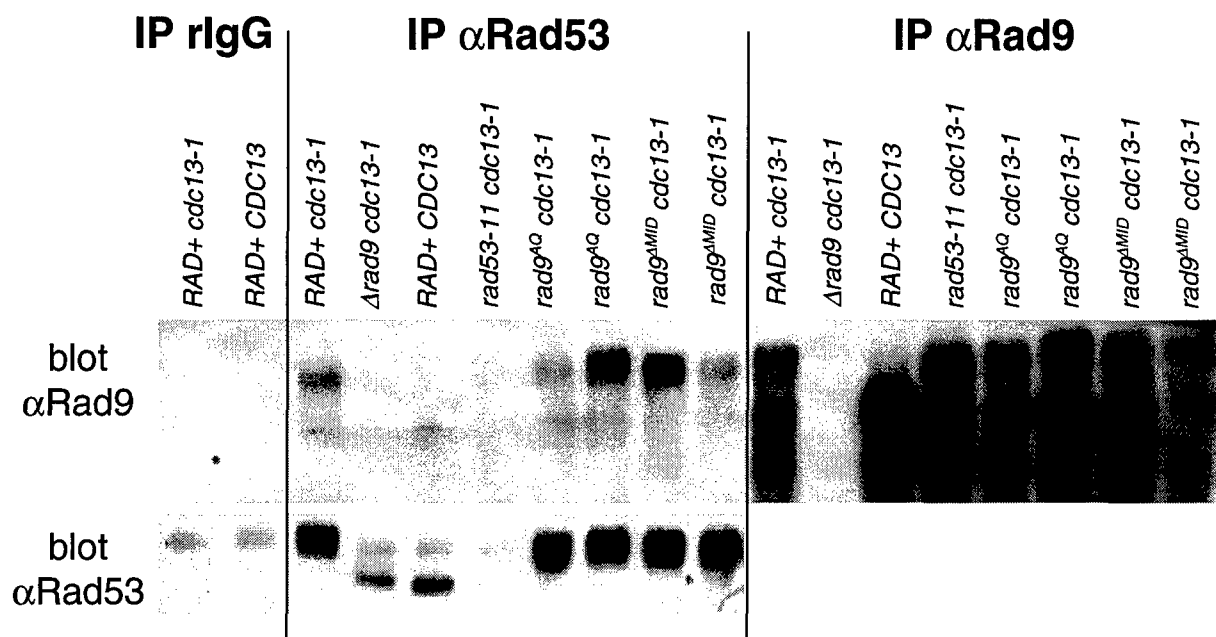

Figure 3: Mutation of Rad9 TQ#8 fails to alter either the electrophoretic profile of Rad53 (lanes 7-10, bottom panel) and Rad9 (lanes 15-18, top panel), or the interaction of Rad9 with Rad53 (lanes 7-10, top panel).

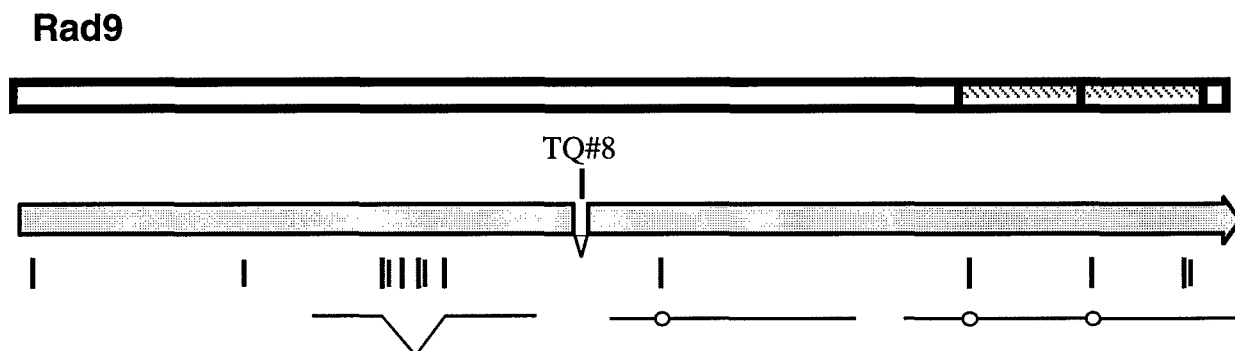

Figure 4: Upper sketch represents Rad9 with the C-terminal BRCT domains marked. Lower sketch indicates the 14 putative Mec1 phosphorylation sites within Rad9 (vertical hash marks), as well as the TQ#8 deletion utilized. Markings at bottom indicate the phosphorylation site mutants tested.

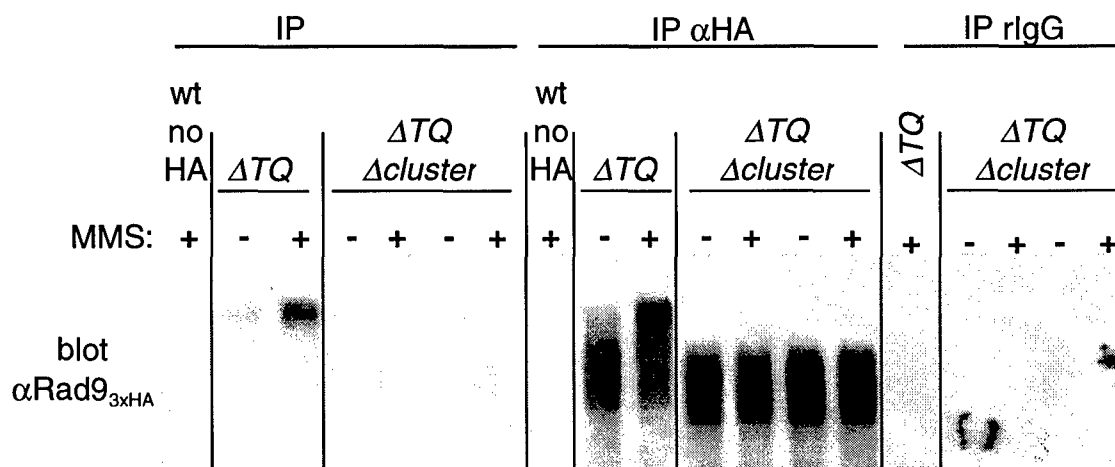

Figure 5: Deletion of a cluster of putative Mec1 phosphorylation sites in Rad9 both removes DNA damage (MMS) dependent Rad9 phosphorylation (lanes 11-14, compared to 9-10), and the interaction of Rad9 with Rad53 (lanes 4-7, compared to 2-3).

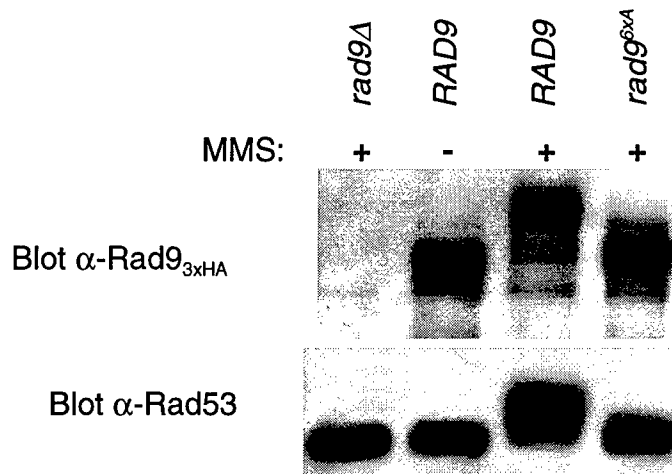

Figure 6: Alanine-substitution of the six putative Mec1 phosphorylation sites within the Rad9 cluster (lane 4) prevents DNA damage dependent phosphorylation of Rad9 (top panel, cell lysates) and Rad53 (bottom panel, cell lysates).

Assay for the G₂ DNA Damage Checkpoint

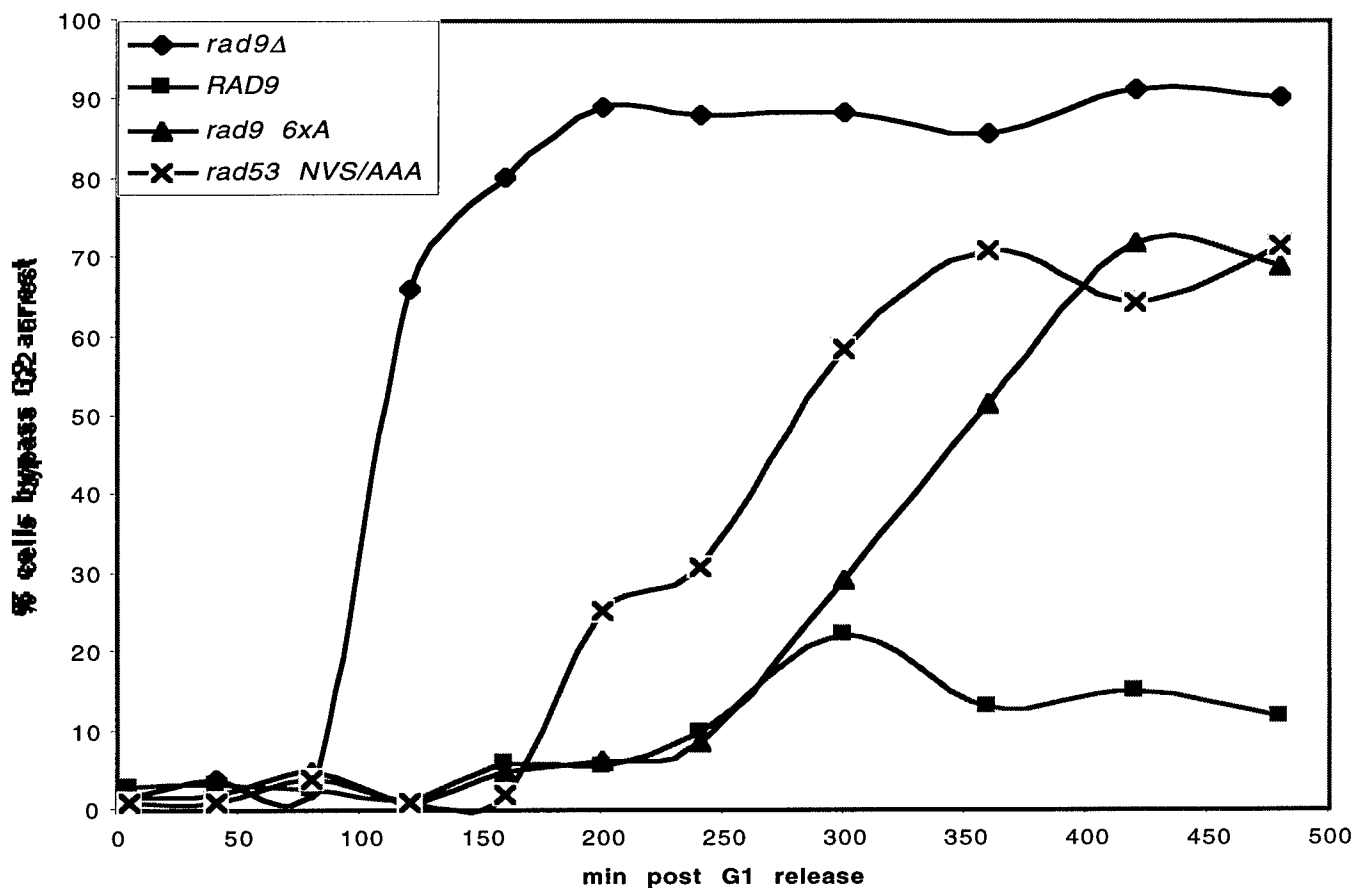

Figure 7: *rad9^{6xA}* mutants fail to maintain the G₂ cell cycle arrest after rDNA damage. Cells are synchronized in G₁ and released at 37°C. DNA damage accumulates in S phase due to the temperature sensitive *cdc13-1* allele in these strains. Cells with a deficient DDC fail to maintain the G₂ arrest, proceeding with mitosis. *rad9^{6xA}* cells escape G₂ arrest with kinetics similar to the *rad53^{NVS/AAA}* FHA2 mutant cells.

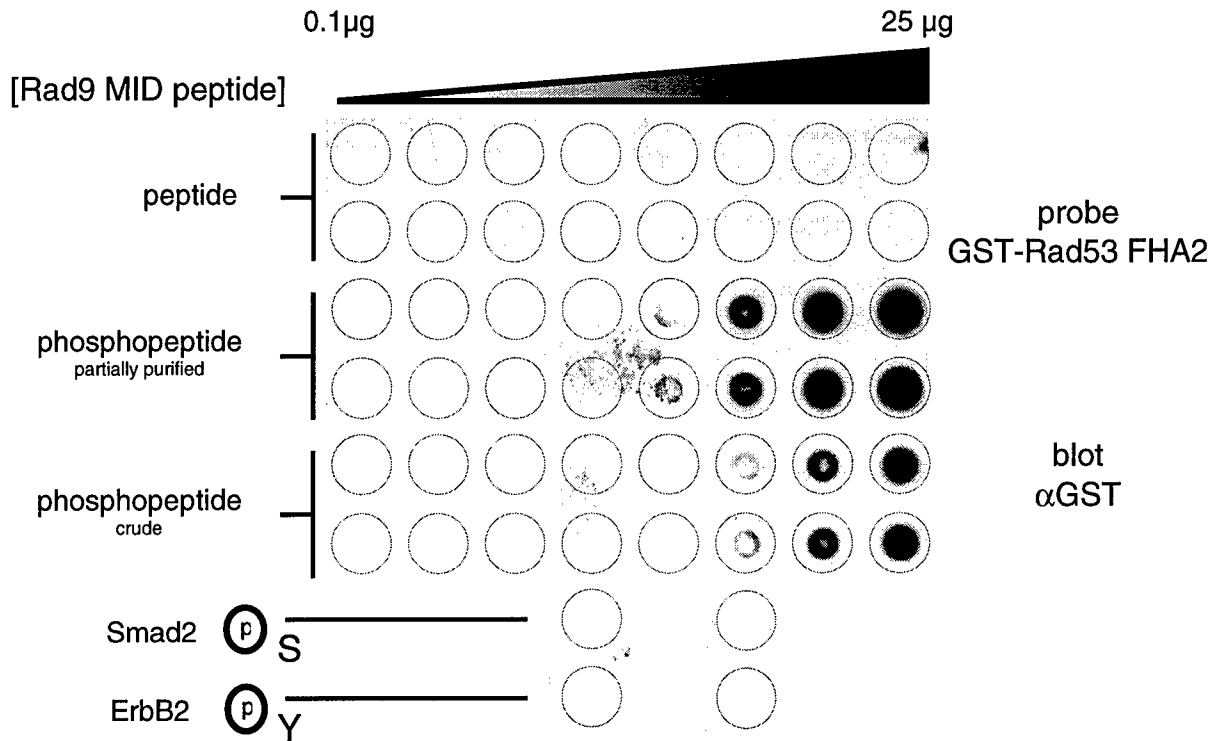

Figure 8: Rad53 FHA2 binds Rad9 phosphopeptides *in vitro*. Rad9 MID peptides were dot-blotted to PVDF at increasing concentrations. GST-Rad53 FHA2 was purified from bacteria and hybridized with the dot blot membrane. Binding of GST-Rad53 FHA2 was detected via chemiluminescence after blotting for GST. GST-Rad53 FHA2 did not bind the nonphosphorylated Rad9 peptide, nor did it bind nonspecifically to a dual phosphoserine peptide (Smad2) or a phosphotyrosine peptide (ErbB2). GST alone, and GST-rad53 FHA2 NVS/AAA mutant showed only general background staining.

Appendices

Reportable Outcomes – Abstracts

65th Symposium: Biological Responses to DNA damage
Poster

Schwartz

PHOSPHORYLATION-DEPENDENT INTERACTION OF Rad53 WITH Rad9 IN THE DNA DAMAGE CHECKPOINT OF *S. cerevisiae*.

Marc F. Schwartz¹, Zhaoxia Sun², James Hsiao² and David F. Stern³.

Departments of Cell Biology¹, Molecular, Cellular and Developmental Biology², and Pathology³, Yale University School of Medicine, New Haven, CT 06510.

The DNA damage checkpoint insures genomic integrity. When activated by DNA damage, the checkpoint acts to both delay progression of the cell cycle and enhance DNA repair. Known components of the DNA damage checkpoint of *Saccharomyces cerevisiae* include the BRCT-domain containing Rad9, the ATM-family member Mec1, and the Rad53/Chk2-family founding member Rad53. In conjunction with other checkpoint genes, Rad9 is hypothesized to act in an afferent sensor pathway in the DNA damage checkpoint, leading to the checkpoint-dependent activation of Mec1 and Rad53. Mec1 and Rad53 are protein kinases thought to form a signal transducing kinase cascade central to the DNA damage checkpoint pathway that is responsible for the propagation of the DNA damage signal.

Recent work in our laboratory determined that Rad53 physically interacts with Rad9. In addition, Rad9, like Rad53, is phosphorylated in response to DNA damage in a *MEC1*-dependent manner, and Rad53 specifically interacts with this hyperphosphorylated form of Rad9. These data suggest the following model for the Rad53/Rad9 interaction: in response to DNA damage, Mec1 phosphorylates Rad9, leading to the recruitment of Rad53 to phospho-Rad9. Rad53 is subsequently phosphorylated and activated by Mec1, propagating the DNA damage signal. The identification and analysis of regions of Rad53 and Rad9 required for their interaction will be discussed.

Department of Defense Breast Cancer Research Program Era of Hope Meeting, 2000

Poster

INTERACTION OF RAD53 WITH RAD9 IN THE DNA DAMAGE CHECKPOINT OF *S.CEREVISIAE*

Marc F. Schwartz¹, Dr. Zhaoxia Sun², James Hsiao², and Dr. David F. Stern²

Dept. of Cell Biology¹ and Pathology², Yale University School of Medicine New Haven, CT 06510
Stern@biomed.med.yale.edu

DNA damage checkpoint control systems are important for protection of the genome from genotoxic agents. These systems function as signal transduction cascades, in which signals generated by DNA damage ultimately induce transient cell cycle arrest and expression of DNA damage response enzymes. Constituents of these pathways are highly conserved among all eukaryotes. Major components in *Saccharomyces cerevisiae* include the BRCT domain-containing protein Rad9, the protein kinase Mec1, and the efferent protein kinase Rad53.

Mammalian homologs of these proteins have important roles in breast cancer. Although no clear Rad9 ortholog has been identified, it does share a protein homology domain and, possibly, functionality, with the breast cancer

tumor suppressor gene *BRCA1*. Mutations in the *MEC1* ortholog *ATM* are apparently responsible for a significant fraction of hereditary breast cancers. The *RAD53* ortholog *CHK2/CDS1* regulates breast cancer tumor suppressor proteins p53 and Brca1. Also, mutations in *CHK2* are responsible for a variant form of the breast cancer predisposing Li-Fraumeni syndrome, in which *TP53* is not mutated.

Budding yeast Rad9 is hypothesized to act in an afferent pathway that senses DNA damage, leading to activation of Mec1 and Rad53 in a protein kinase cascade. Rad53 activation in turn leads to some of the major transcriptional and cell cycle regulatory outputs. Recent work in our laboratory showed that DNA damage induces phosphorylation of Rad9, which in turn enables Rad9 to bind Rad53 tightly through a FHA protein homology domain. This probably occurs through direct recognition of a Rad9 phosphopeptide by the Rad53 FHA domain. The working model is that DNA damage enables Mec1 to phosphorylate Rad9, which in turn recruits Rad53 into a complex in which Rad53 can be phosphorylated and activated by Mec1. We view these interactions as a prototype for activation of homologous proteins in other systems, including activation of Chk2 by Atm.

Through a combination of mutational and functional analyses, we have now identified phosphorylation sites on Rad9 responsible for the interaction with Rad53, and shown that the FHA2 domain interaction with Rad9 is indeed a direct phosphopeptide recognition event. The identification of these sites will facilitate identification and characterization of mammalian Rad9 orthologs, which is now underway.



DEPARTMENT OF THE ARMY
US ARMY MEDICAL RESEARCH AND MATERIEL COMMAND
534 SCOTT STREET
FORT DETRICK, MARYLAND 21702-5012

REPLY TO
ATTENTION OF:

MCMR-RMI-S (70-1y)

28 July 03

MEMORANDUM FOR Administrator, Defense Technical Information
Center (DTIC-OCA), 8725 John J. Kingman Road, Fort Belvoir,
VA 22060-6218

SUBJECT: Request Change in Distribution Statement

1. The U.S. Army Medical Research and Materiel Command has reexamined the need for the limitation assigned to technical reports written for this Command. Request the limited distribution statement for the enclosed accession numbers be changed to "Approved for public release; distribution unlimited." These reports should be released to the National Technical Information Service.

2. Point of contact for this request is Ms. Kristin Morrow at DSN 343-7327 or by e-mail at Kristin.Morrow@det.amedd.army.mil.

FOR THE COMMANDER:

Encl

PHYLIS M. RINEHART
Deputy Chief of Staff for
Information Management

ADB233865	ADB264750
ADB265530	ADB282776
ADB244706	ADB286264
ADB285843	ADB260563
ADB240902	ADB277918
ADB264038	ADB286365
ADB285885	ADB275327
ADB274458	ADB286736
ADB285735	ADB286137
ADB286597	ADB286146
ADB285707	ADB286100
ADB274521	ADB286266
ADB259955	ADB286308
ADB274793	ADB285832
ADB285914	
ADB260288	
ADB254419	
ADB282347	
ADB286860	
ADB262052	
ADB286348	
ADB264839	
ADB275123	
ADB286590	
ADB264002	
ADB281670	
ADB281622	
ADB263720	
ADB285876	
ADB262660	
ADB282191	
ADB283518	
ADB285797	
ADB269339	
ADB264584	
ADB282777	
ADB286185	
ADB262261	
ADB282896	
ADB286247	
ADB286127	
ADB274629	
ADB284370	
ADB264652	
ADB281790	
ADB286578	