

U.S. MARINE CORPS TECHNICAL MANUAL

INSTALLATION, OPERATION
AND MAINTENANCE

FOR

REVERSE OSMOSIS
ELEMENT CLEANING AND
PRESERVATION SYSTEM
(ROECPS)

DETC QUALITY 1



THIS PUBLICATION IS REQUIRED FOR OFFICIAL USE OR FOR ADMINISTRATIVE OR OPERATIONAL PURPOSES. DISTRIBUTION IS LIMITED TO U.S. GOVERNMENT AGENCIES ONLY. OTHER REQUESTS FOR THIS DOCUMENT MUST BE REFERRED TO: COMMANDANT OF THE MARINE CORPS (HQSP-2), WASHINGTON, D.C. 20380-0001. DESTRUCTION NOTICE: FOR UNCLASSIFIED, LIMITED DOCUMENTS, DESTROY BY ANY METHOD THAT WILL PREVENT DISCLOSURE OF CONTENTS OR RECONSTRUCTION OF THE DOCUMENTS.

FOR OFFICIAL USE ONLY

19970530 014



UNCLASSIFIED



AD NUMBER

AD-B224 310

NEW LIMITATION CHANGE

TO

DISTRIBUTION STATEMENT A -
Approved for public release; Distri-
bution unlimited.

Limitation Code: 1

FROM

DISTRIBUTION STATEMENT - B

Limitation Code: 3

AUTHORITY

E. A. Downing, AMSTA-RBW, Ft Belvoir, VA

THIS PAGE IS UNCLASSIFIED

Please update
OER 5/30/97

PLEASE CHECK THE APPROPRIATE BLOCK BELOW:

-AO# M97-08-5432

- _____ copies are being forwarded. Indicate whether Statement A, B, C, D, E, F, or X applies.

- DISTRIBUTION STATEMENT A:
APPROVED FOR PUBLIC RELEASE: DISTRIBUTION IS UNLIMITED

- DISTRIBUTION STATEMENT B:
DISTRIBUTION AUTHORIZED TO U.S. GOVERNMENT AGENCIES ONLY; (Indicate Reason and Date). OTHER REQUESTS FOR THIS DOCUMENT SHALL BE REFERRED TO (Indicate Controlling DoD Office).

- DISTRIBUTION STATEMENT C:
DISTRIBUTION AUTHORIZED TO U.S. GOVERNMENT AGENCIES AND THEIR CONTRACTORS; (Indicate Reason and Date). OTHER REQUESTS FOR THIS DOCUMENT SHALL BE REFERRED TO (Indicate Controlling DoD Office).

- DISTRIBUTION STATEMENT D:
DISTRIBUTION AUTHORIZED TO DoD AND U.S. DoD CONTRACTORS ONLY; (Indicate Reason and Date). OTHER REQUESTS SHALL BE REFERRED TO (Indicate Controlling DoD Office).

- DISTRIBUTION STATEMENT E:
DISTRIBUTION AUTHORIZED TO DoD COMPONENTS ONLY; (Indicate Reason and Date). OTHER REQUESTS SHALL BE REFERRED TO (Indicate Controlling DoD Office).

- DISTRIBUTION STATEMENT F:
FURTHER DISSEMINATION ONLY AS DIRECTED BY (Indicate Controlling DoD Office and Date) or HIGHER DoD AUTHORITY.

- DISTRIBUTION STATEMENT X:
DISTRIBUTION AUTHORIZED TO U.S. GOVERNMENT AGENCIES AND PRIVATE INDIVIDUALS OR ENTERPRISES ELIGIBLE TO OBTAIN EXPORT-CONTROLLED TECHNICAL DATA IN ACCORDANCE WITH DoD DIRECTIVE 5230.25, WITHHOLDING OF UNCLASSIFIED TECHNICAL DATA FROM PUBLIC DISCLOSURE, 6 Nov 1984 (Indicate date of determination). CONTROLLING DoD OFFICE IS (Indicate Controlling DoD Office).

- This document was previously forwarded to DTIC on _____ (date) and the AD number is _____.

- In accordance with provisions of DoD instructions, the document requested is not supplied because:

- It will be published at a later date. (Enter approximate date, if known).

- Other. (Give Reason)

DoD Directive 5230.24, "Distribution Statements on Technical Documents," 18 Mar 87, contains seven distribution statements, as described briefly above. Technical Documents must be assigned distribution statements.

Print or Type Name

Authorized Signature/Date

Telephone Number

REPORT DOCUMENTATION PAGE

Form Approved
OMB No. 0704-0188

Public reporting burden for this collection of information is estimated to average 1 hour per response, including the time for reviewing instructions, searching existing data sources, gathering and maintaining the data needed, and completing and reviewing the collection of information. Send comments regarding this burden estimate or any other aspect of this collection of information, including suggestions for reducing this burden, to Washington Headquarters Services, Directorate for Information Operations and Reports, 1215 Jefferson Davis Highway, Suite 1204, Arlington, VA 22202-4302, and to the Office of Management and Budget, Paperwork Reduction Project (0704-0188), Washington, DC 20503.

1. AGENCY USE ONLY (Leave blank)		2. REPORT DATE	3. REPORT TYPE AND DATES COVERED	
4. TITLE AND SUBTITLE <i>Installation, Operation and Maintenance for Reverse Osmosis Element Cleaning and Preservation System (ROECPS)</i>			5. FUNDING NUMBERS	
6. AUTHOR(S)				
7. PERFORMING ORGANIZATION NAME(S) AND ADDRESS(ES)			8. PERFORMING ORGANIZATION REPORT NUMBER	
9. SPONSORING/MONITORING AGENCY NAME(S) AND ADDRESS(ES)			10. SPONSORING/MONITORING AGENCY REPORT NUMBER	
11. SUPPLEMENTARY NOTES				
12a. DISTRIBUTION/AVAILABILITY STATEMENT CONTAINS PERFORMANCE DATA ON COMMERCIAL PRODUCTS AND MAY BE MISCONSTRUED AS ENDORSEMENT (28 May 97). Other requests for this document shall be referred to the sponsoring agency. <i>ATN: AMSTA-TR-R/210. Warren, MI</i>			12b. DISTRIBUTION CODE <i>Eng. Gtr. (TARDEC) 48398-5000</i>	
13. ABSTRACT (Maximum 200 words)				
14. SUBJECT TERMS			15. NUMBER OF PAGES	
			16. PRICE CODE	
17. SECURITY CLASSIFICATION OF REPORT	18. SECURITY CLASSIFICATION OF THIS PAGE	19. SECURITY CLASSIFICATION OF ABSTRACT	20. LIMITATION OF ABSTRACT	

GENERAL INSTRUCTIONS FOR COMPLETING SF 298

The Report Documentation Page (RDP) is used in announcing and cataloging reports. It is important that this information be consistent with the rest of the report, particularly the cover and title page. Instructions for filling in each block of the form follow. It is important to *stay within the lines* to meet *optical scanning requirements*.

Block 1. Agency Use Only (Leave blank).

Block 2. Report Date. Full publication date including day, month, and year, if available (e.g. 1 Jan 88). Must cite at least the year.

Block 3. Type of Report and Dates Covered. State whether report is interim, final, etc. If applicable, enter inclusive report dates (e.g. 10 Jun 87 - 30 Jun 88).

Block 4. Title and Subtitle. A title is taken from the part of the report that provides the most meaningful and complete information. When a report is prepared in more than one volume, repeat the primary title, add volume number, and include subtitle for the specific volume. On classified documents enter the title classification in parentheses.

Block 5. Funding Numbers. To include contract and grant numbers; may include program element number(s), project number(s), task number(s), and work unit number(s). Use the following labels:

C - Contract	PR - Project
G - Grant	TA - Task
PE - Program Element	WU - Work Unit Accession No.

Block 6. Author(s). Name(s) of person(s) responsible for writing the report, performing the research, or credited with the content of the report. If editor or compiler, this should follow the name(s).

Block 7. Performing Organization Name(s) and Address(es). Self-explanatory.

Block 8. Performing Organization Report Number. Enter the unique alphanumeric report number(s) assigned by the organization performing the report.

Block 9. Sponsoring/Monitoring Agency Name(s) and Address(es). Self-explanatory.

Block 10. Sponsoring/Monitoring Agency Report Number. (If known)

Block 11. Supplementary Notes. Enter information not included elsewhere such as: Prepared in cooperation with...; Trans. of...; To be published in.... When a report is revised, include a statement whether the new report supersedes or supplements the older report.

Block 12a. Distribution/Availability Statement.

Denotes public availability or limitations. Cite any availability to the public. Enter additional limitations or special markings in all capitals (e.g. NOFORN, REL, ITAR).

DOD - See DoDD 5230.24, "Distribution Statements on Technical Documents."

DOE - See authorities.

NASA - See Handbook NHB 2200.2.

NTIS - Leave blank.

Block 12b. Distribution Code.

DOD - Leave blank.

DOE - Enter DOE distribution categories from the Standard Distribution for Unclassified Scientific and Technical Reports.

NASA - Leave blank.

NTIS - Leave blank.

Block 13. Abstract. Include a brief (*Maximum 200 words*) factual summary of the most significant information contained in the report.

Block 14. Subject Terms. Keywords or phrases identifying major subjects in the report.

Block 15. Number of Pages. Enter the total number of pages.

Block 16. Price Code. Enter appropriate price code (*NTIS only*).

Blocks 17. - 19. Security Classifications. Self-explanatory. Enter U.S. Security Classification in accordance with U.S. Security Regulations (i.e., UNCLASSIFIED). If form contains classified information, stamp classification on the top and bottom of the page.

Block 20. Limitation of Abstract. This block must be completed to assign a limitation to the abstract. Enter either UL (unlimited) or SAR (same as report). An entry in this block is necessary if the abstract is to be limited. If blank, the abstract is assumed to be unlimited.

U.S. MARINE CORPS TECHNICAL MANUAL

INSTALLATION, OPERATION
AND MAINTENANCE

FOR

REVERSE OSMOSIS
ELEMENT CLEANING AND
PRESERVATION SYSTEM
(ROECPS)



THIS PUBLICATION IS REQUIRED FOR OFFICIAL USE OR FOR ADMINISTRATIVE OR OPERATIONAL PURPOSES. DISTRIBUTION IS LIMITED TO U.S. GOVERNMENT AGENCIES ONLY. OTHER REQUESTS FOR THIS DOCUMENT MUST BE REFERRED TO: COMMANDANT OF THE MARINE CORPS (HQSP-2), WASHINGTON, D.C. 20380-0001. DESTRUCTION NOTICE: FOR UNCLASSIFIED, LIMITED DOCUMENTS, DESTROY BY ANY METHOD THAT WILL PREVENT DISCLOSURE OF CONTENTS OR RECONSTRUCTION OF THE DOCUMENTS.

FOR OFFICIAL USE ONLY

31 JULY 1990



LIST OF EFFECTIVE PAGES

NOTE: On a changed page, the portion of the text affected by the latest change is indicated by a vertical line, or other change symbol, in the outer margin of the page. Changes to illustrations are indicated by miniature pointing hands. Changes to wiring diagrams are indicated by shaded areas.

TOTAL NUMBER OF PAGES IN THIS PUBLICATION IS

CONSISTING OF THE FOLLOWING:

Page No.	Change No.	Page No.	Change No.
Title.....			

* Zero in this column indicates an original page.

A/(B Blank)



TABLE OF CONTENTS

		LIST OF ILLUSTRATIONS.....	ii
		LIST OF TABLES.....	iii
		SAFETY SUMMARY.....	iv
CHAPTER	1	GENERAL INSTRUCTIONS	
	1-0.	SAFETY PRECAUTIONS.....	1-1
	1-1.	INTRODUCTION.....	1-1
	1-1.1	Scope.....	1-2
	1-1.2	Purpose.....	1-2
	1-1.3	Supersedure Data.....	1-2
	1-1.4	Applicability.....	1-2
	1-2.	DESCRIPTIONS, PHYSICAL AND FUNCTIONAL.....	1-2
	1-2.1	Physical Description.....	1-2
	1-2.2	Functional Description.....	1-4
	1-2.3	Data Tables.....	1-5
CHAPTER	2	OPERATING INSTRUCTIONS	
	2-0.	CLEANING PROCEDURE.....	2-1
	2-0.1	Procedures Prior to ROWPU Shutdown.....	2-1
	2-0.1.1	Unpacking.....	2-1
	2-0.1.2	Positioning the ROECPS.....	2-2
	2-0.1.3	Installing the 3-Way Valve.....	2-2
	2-0.1.4	Filling the Solution Tank.....	2-5
	2-0.1.5	Preparation of Cleaning Solution.....	2-6
	2-0.2	Preparation of ROWPU for Cleaning.....	2-13
	2-0.3	Cleaning of RO Elements.....	2-18
	2-0.4	Disposal of Cleaning Solution.....	2-21
	2-1.	PRESERVATION PROCEDURE.....	2-23
	2-1.1	Preservation Configuration.....	2-23
	2-1.2	Mixing of Solution.....	2-25
	2-1.3	Circulation of Preservative Solution.....	2-25
	2-1.4	Extended Storage of Reverse Osmosis Elements.....	2-26
	2-2.	USE OF RO VESSEL BYPASS LINE.....	2-26
	2-2.1	Installation of Bypass Line.....	2-26
CHAPTER	3	MAINTENANCE INSTRUCTIONS	
	3-0.	MAINTENANCE DEFINITIONS.....	3-1
	3-0.1	Service.....	3-1
	3-0.2	Adjust.....	3-1
	3-0.3	Inspect.....	3-1
	3-0.4	Test.....	3-1
	3-0.5	Replace.....	3-1
	3-0.6	IROAN.....	3-1
	3-0.7	Repair.....	3-2
	3-1.	FORMS, RECORDS, AND REPORTS.....	3-2
	3-2.	GENERAL.....	3-2



TABLE OF CONTENTS (Continued)

		3-3. TOOLS AND MATERIAL CARRIED WITH THE EQUIPMENT.....	3-2
		3-4. PREVENTIVE MAINTENANCE.....	3-2
		3-4.1 Hose Sections.....	3-2
		3-4.2 Threaded Pipe and Hose Fittings.....	3-2
		3-4.3 Valves.....	3-2
		3-4.4 Victaulic Couplings and Grooved Fittings.....	3-3
		3-4.5 Cleaning Tank Assembly.....	3-3
		3-4.6 Heater Assembly.....	3-3
		3-4.7 Thermometer.....	3-3
		3-4.8 Y-Strainer.....	3-4
CHAPTER	4	TRUBLESHOOTING	
		4-0. INTRODUCTION.....	4-1
		4-1. TROUBLESHOOTING PROCEDURES.....	4-1
APPENDIX	A	GLOSSARY OF ABBREVIATIONS AND ACRONYMS.....	A-1

LIST OF ILLUSTRATIONS

Figure	Title	Page
1-1	Reverse Osmosis Element Cleaning and Preservation System.....	1-3
2-1	3-Way Valve.....	2-3
2-2	Installation of 3-Way Valve.....	2-4
2-3	Solution Tank and Raw Water Pump Installation.....	2-7
2-4	Heater and Strainer Installation.....	2-8
2-5	Mixing Cleaning Solution, Pump and Tank Configuration.....	2-10
2-6	Element Cleaning Switch.....	2-11
2-7	Element Vessel, Product Water Drain and Vent Valves.....	2-14
2-8	Product Water Outlet.....	2-15
2-9	Valve and Victaulic Coupling, Top RO Vessel.....	2-16
2-10	Valve Adapter Assembly Attached to Bottom RO Vessel..	2-17
2-11	Connection of Bottom RO Vessel, Tee, 3-Way Valve and Solution Tank.....	2-19
2-12	On/Off Switch, Raw Water Pump No. 2.....	2-20
2-13	Preservation/Cleaning Configuration.....	2-24
2-14	Installation of Bypass Line.....	2-27
2-15	Victaulic Connection to Quick Disconnect, Top RO Vessel.....	2-28
2-16	Victaulic Connection to Quick Disconnect, Bottom RO Vessel.....	2-29



LIST OF TABLES

Table	Title	Page
1-1	ROECPS Components.....	1-5
4-1	ROECPS Troubleshooting.....	4-2



SAFETY SUMMARY

GENERAL SAFETY NOTICES.

The following general safety notices supplement the specific warnings and cautions appearing elsewhere in this manual. They are recommended precautions that must be understood and applied during operation and maintenance of the equipment covered herein. Should situations arise that are not covered in the general or specific safety precautions, the Commanding Officer or other authority will issue orders as deemed necessary to cover the situation.

DO NOT REPAIR OR ADJUST ALONE.

Under no circumstances shall operation of the Reverse Osmosis Element Cleaning and Preservation System (ROECPS) be attempted alone, without immediate presence of someone capable of rendering aid.

FIRST AID AND RESUSCITATION.

An injury, no matter how slight, should never go unattended. Always get first aid or medical attention immediately. A delay could cost the victim his life.

GENERAL PRECAUTIONS.

1. All signs and markings that pertain to safety measures shall be displayed.
2. Do not make any unauthorized alterations to the ROECPS.

WARNINGS AND CAUTIONS.

Warnings and cautions applying to the ROECPS covered in this manual are summarized below. These warnings and cautions are repeated throughout the manual following paragraph headings and preceding text to which they apply.

GENERAL WARNINGS

Electrical high voltage can kill you. Electrical high voltage cannot be seen, but it can kill you. Electricity is unlike most other dangerous things you come in contact with because it gives no warning and symptoms to be wary of. Its



effect is immediate. It can kill you, render you unconscious, or severely burn you. To ensure your safety and that of other personnel, always observe the following precautions.

Do not perform any maintenance on electrical equipment unless all power is secured.

Do not perform any maintenance on electrical equipment that must have power applied during maintenance without proper insulation between you and the equipment at all times.

Be certain that there is someone assisting you who can secure power immediately.

Always place power off warning tags on power supply switches so that no one will apply power while you are performing maintenance. Always make sure the unit is properly grounded.

WARNING

High voltages are used in the operation of this equipment. Death on contact may result if personnel fail to observe safety precautions. (Page 2-6)

WARNING

Avoid contact with chemicals either in dry form or when mixed with water. If chemicals should come in contact with exposed skin or enter the eye(s), immediately wash with fresh water and seek medical attention. (Page 2-9)

WARNING

During training exercises, the cleaning solution should be transferred to a 55 gallon waste drum and disposed of in accordance with local, state, and federal regulations. During combat operations, the cleaning solution should be disposed of as far from the ROWPU site as possible to reduce the risk of contaminating the feedwater supply for the ROWPU's. (Page 2-21)

WARNING

Contact with cleaning solution may cause skin irritation or blistering. Avoid contact by using rubber gloves, and plastic face mask with goggles. Wash any exposed areas immediately with fresh clean water. (Page 2-22)

WARNING

Product water produced by the ROWPU for the first 30 minutes of operation following cleaning should be dumped to a waste location. (Page 2-22)

WARNING

Equipment circuits contain high voltage when in operation. Do not attempt inspection or maintenance while equipment is connected to power source. Failure to do so may result in injury or death to personnel. (Page 3-1)

CAUTION

Use of CHLORINATED water during operation, cleaning or preservation procedures will cause permanent damage to the reverse osmosis elements. (Pages 2-1, 2-5)

CAUTION

Do not add more cleaning solution than the premeasured amount. Permanent damage to the reverse osmosis elements will occur if excessive cleaner is used. (Page 2-9)

CAUTION

Do not operate heater without solution circulating through the heater assembly. (Page 2-12)

CAUTION

Do not pressurize the ROWPU with product water outlet capped. This could cause permanent damage to the ROWPU. (Page 2-13)

CAUTION

Do not allow chemical solution to exceed 80° F. If the chemical solution exceeds this temperature, permanent damage to the reverse osmosis elements will occur.
(Page 2-21)

CAUTION

Ensure that the cap previously installed on the product water outlet located on the front of the ROWPU is removed prior to returning the ROWPU to normal operation. Failure to do this will result in damage to the ROWPU. (Page 2-22)



CHAPTER 1

GENERAL INSTRUCTIONS

- 1-0. **SAFETY PRECAUTIONS.** Warnings and cautions appearing throughout this technical manual are of paramount importance to personnel and equipment safety. Prior to any attempt to operate, maintain, troubleshoot, or repair any part of the Reverse Osmosis Element Cleaning and Preservation System (ROECPS) or its support equipment, all warnings and cautions should be thoroughly reviewed and understood. Refer to the Safety Summary at the front of this manual for a complete list of warnings and cautions. The following paragraphs define warnings, cautions, and notes as they are used in this manual.

WARNING

Identifies an operating or maintenance procedure, practice, condition, or statement which, if not strictly followed could result in death or serious injury to personnel.

CAUTION

Identifies an operating or maintenance procedure, practice, condition, or statement which, if not strictly followed could result in destruction of or damage to equipment or serious impairment of system operation.

Note

Notes are used to highlight certain operating or maintenance statements which are essential but not of known hazardous nature as indicated by warnings and cautions.

- 1-1. **INTRODUCTION.** This section contains the following: scope, purpose, supersedure data, applicability, and leading particulars, for the ROECPS.

- 1-1.1 Scope. This manual describes procedures for the operation, and maintenance of the ROECPS when used with the 600 gallons per hour Reverse Osmosis Water Purification Unit (600 gph ROWPU).
- 1-1.2 Purpose. This manual provides a complete source of information for the ROECPS. A further intent is to provide a basic operation and maintenance manual requiring minimum update for future units of similar design. This manual may also be used in whole or in part as a training document.
- 1-1.3 Supersedure Data. This manual has no superseding publication number.
- 1-1.4 Applicability. This manual applies to the Reverse Osmosis Element Cleaning and Preservation System (ROECPS).
- 1-1.5 Leading Particulars. ROECPS leading particulars are listed in Table 1-1.
- 1-2. DESCRIPTIONS, PHYSICAL AND FUNCTIONAL. The following paragraphs provide physical and functional descriptions of the ROECPS.
- 1-2.1 Physical Description. The basic set-up of the ROECPS and its attachment to the 600 gph ROWPU is shown in figure 1-1. This configuration is used for both the cleaning and preservation of the reverse osmosis elements. It allows the cleaning and preservation chemicals to bypass all pretreatment components and high pressure piping of the ROWPU in order to minimize the quantities of cleaning and preservative solutions used. This also reduces the potential for corrosion of the copper/nickel piping on certain versions of the 600 gph ROWPU. The ROECPS uses one of the ROWPU's raw water pumps to circulate the cleaning and preservative solutions through the elements. Power for the electrical heater that heats the solutions



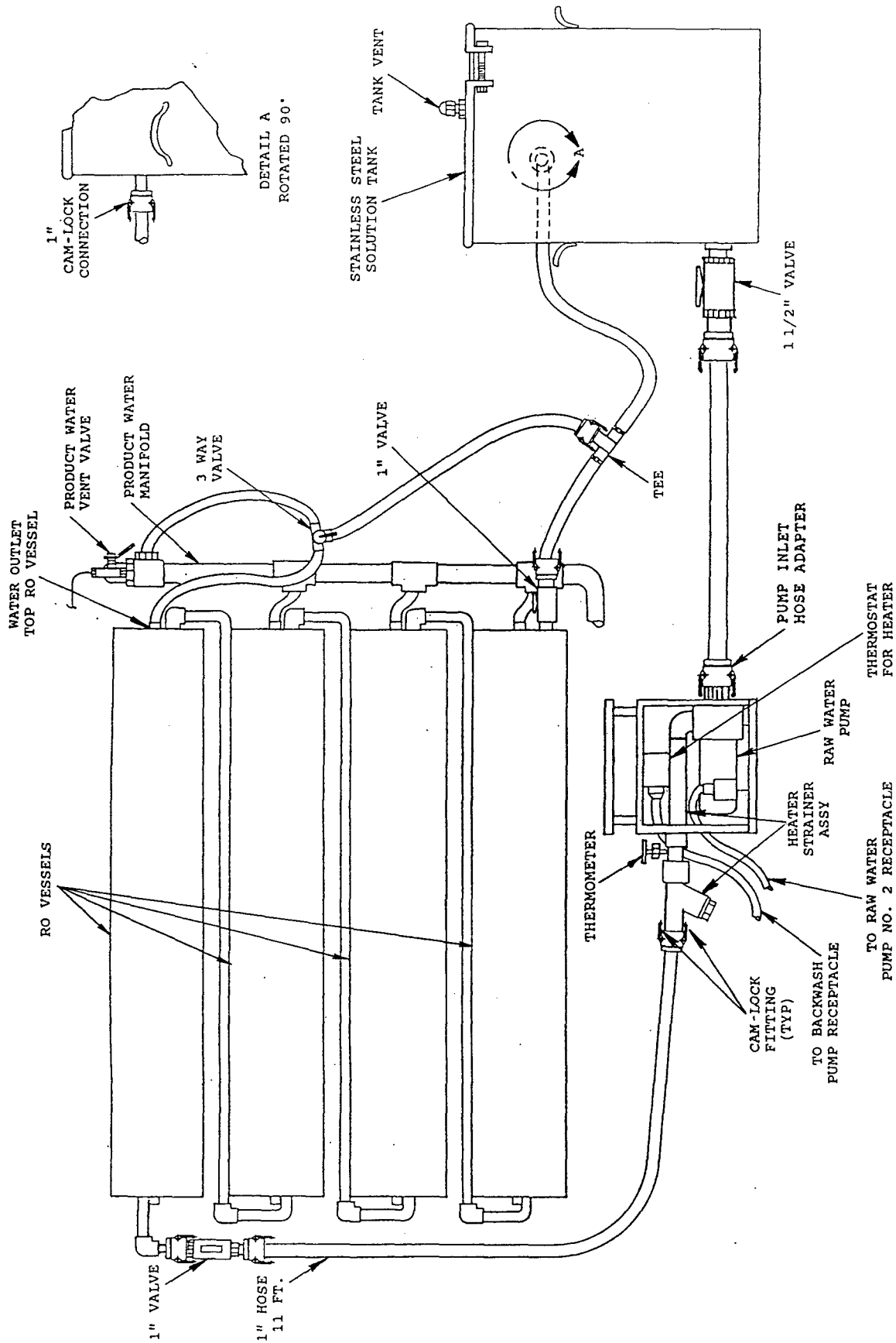

Figure 1-1. Reverse Osmosis Element Cleaning and Preservation System.



is supplied from the backwash pump electrical connector. Cleaning is much more effective when the solution temperature is warmer than the normal ambient water temperature. The electrical heater is designed to maintain the circulating solution at $80^{\circ}\text{F} \pm 2^{\circ}$. Heating of the preservative solution is not required. The ROECPS also includes an RO vessel bypass line to provide the operator a means of flushing the ROWPU with tap water as well as a means of checking ROWPU operation during Quarterly Preventive Maintenance.

1-2.2

Functional Description. The ROECPS is a system designed to allow cleaning and preservation of the reverse osmosis (RO) elements on the 600 gph ROWPU in a field environment. The ROECPS recirculates a cleaning or preservative solution through the RO vessels to improve RO element performance through cleaning, and to extend the useful life of the RO elements through preservation. Cleaning is performed when performance of the ROWPU RO elements has changed in one of three ways:

- a. The product water flow produced by the elements drops one gallon per minute or more with no change in the initial feed temperature or RO feed pressure.
- b. The RO feed pressure must be increased to greater than 960 psig for seawater operation in order to maintain a constant product flow of 10 gpm of seawater or 16 gpm of fresh or brackish waters. Note that at seawater temperatures less than 60°F it will not be possible to produce 10 gpm of product water at 960 psig.
- c. The RO vessel's differential pressure increases by 20% over its initial value with no other changes in feed or brine flow, RO feed pressure, or temperature.

Preservation is performed at the conclusion of an operation following cleaning and when the ROWPU is not to be operated for



periods of two weeks or longer. The preservative solution prevents the growth of organisms, molds, and fungi which can degrade the performance of the RO elements. Preservation should be repeated every six months to restore any preservative that may have been lost from the system during storage.

1-2.3 Data Tables. Table 1-1 summarizes the components of the ROECPS and their function.

Table 1-1. ROECPS Components

Item	Characteristics
Tank for cleaning and preservative solution.	55 gallon capacity, 304 stainless steel construction. Provides storage area for all ROECPS components.
Valve with male quick disconnect adapter.	1-1/2 inch NPT ball valve. Connects to bottom of 55 gallon tank.
Raw water pump inlet hose adapter.	1-1/2 inch female NPSH by 1-1/2 inch female quick disconnect. Attaches to raw water pump suction port.
Hose section.	1-1/2 inch suction hose, 3 feet long with male and female quick disconnect fittings. Connects between raw water pump and tank.
Heater/strainer piping assembly with temperature gauge.	3.5 KW single phase electric heater with -40° to 160°F temperature gauge and fine mesh strainer. Attaches to outlet of raw water pump.



Table 1-1. ROECPS Components (Continued)

Item	Characteristics
Raw water pump outlet, top vessel feed tubing.	1 inch reinforced plastic tubing, 11 feet long, with quick disconnect fittings. Connects outlet of heater piping assembly and the valve installed at the inlet to the top RO vessel.
Valve with quick disconnects.	1 inch ball valve with quick disconnects. Attaches between vessel feed tubing and vessel inlet valve adapter assembly.
Vessel inlet valve adapter assembly.	1 inch victaulic connector by quick disconnect with elbow. Attaches to the inlet of the top reverse osmosis vessel on the ROWPU.
Vessel outlet valve adapter assembly.	Victaulic connector with 1 inch ball valve and quick disconnect. Connects to the brine outlet on the bottom RO vessel.
Tank return tubing with tee.	1 inch reinforced plastic tubing section approximately 4 feet long with quick disconnects and tee. Connects between vessel outlet valve adapter assembly and tank.
Valve for product water and water collection tubing.	3-way valve, attaches to top RO vessel product water outlet and inlet to product water manifold.



Table 1-1. ROECPS Components (Continued)

Item	Characteristics
<p>RO vessel bypass assembly (not shown in figure 1-1).</p>	<p>Two 1 inch victaulic by quick disconnect fittings and 12 ft. section of 1 inch tubing with quick disconnect fittings. Connects between elbowed victaulics at inlet and outlet of top and bottom RO vessels. Allows flushing of complete ROWPU with freshwater without entering RO vessels.</p>



CHAPTER 2

OPERATING INSTRUCTIONS

- 2-0. **CLEANING PROCEDURE.** During operation of the 600 gph ROWPU, the RO elements will gradually become fouled with contaminants that are not completely removed by the pretreatment systems. These contaminants consist of fine silt, organic matter, iron, and biological growth which will adhere tightly to the membrane and cause losses in product flow and increases in product water total dissolved solids (TDS). The contaminants can only be removed by cleaning with a heated chemical solution. The ROECPS was designed to provide a simple means of cleaning the RO elements using only 40 gallons of heated cleaning solution. The ROECPS uses the ROWPU raw water pump to circulate the cleaning solution through ONLY the RO vessels. This feature reduces the quantity of solution required and the potential for corrosion of the ROWPU high pressure piping.

CAUTION

Use of **CHLORINATED** water during operation, cleaning or preservation procedures will cause permanent damage to the reverse osmosis elements.

- 2-0.1 Procedures Prior to ROWPU Shutdown. Before cleaning of the reverse osmosis elements, the cleaning solution tank, raw water pump, hoses, and valves can be positioned and connected.
- 2-0.1.1 Unpacking.
- a. Unpack the components from the stainless steel solution tank.



- b. Inventory all components and accessories to ensure that no parts have been damaged or are missing.
- c. Check to see that all parts are in working condition and that gaskets for the quick disconnect and hose fittings are in place and not damaged.

2-0.1.2 Positioning the ROECPS.

- a. Position the solution tank at the left rear corner of the ROWPU approximately 2 to 3 feet from the ROWPU, as depicted in figure 1-1.
- b. Position the raw water pump approximately 3 feet from the solution tank. The suction of the pump should be facing the 1-1/2 inch fitting located at the bottom of the solution tank. Rotate the elbow at the discharge of the pump so it points toward the right side of the ROWPU, see figure 1-1.

2-0.1.3 Installing the 3-Way Valve. A 3-way valve (figure 2-1) must be installed prior to ROWPU operation to enable filling of the solution tank with unchlorinated product water. The 3-way valve has two separate pieces of plastic tubing attached. One piece of tubing is attached to one end of the run of the valve and the second piece is attached to the branch of the valve. This valve is placed between the top reverse osmosis (RO) vessel and the product water manifold as shown in figure 2-2.

- a. Connect the product water tubing from the vessel to the barbed fitting on the unconnected end of the run of the 3-way valve. Connect the end of the tubing attached to the 3-way valve to the barbed fitting at the top of the product water manifold. Tighten hose clamps.



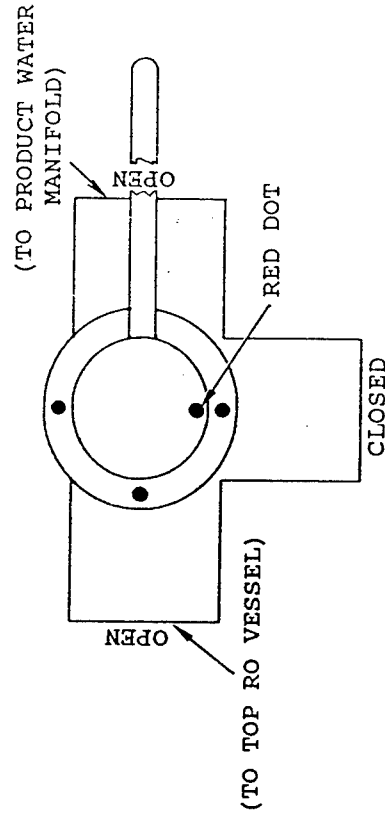
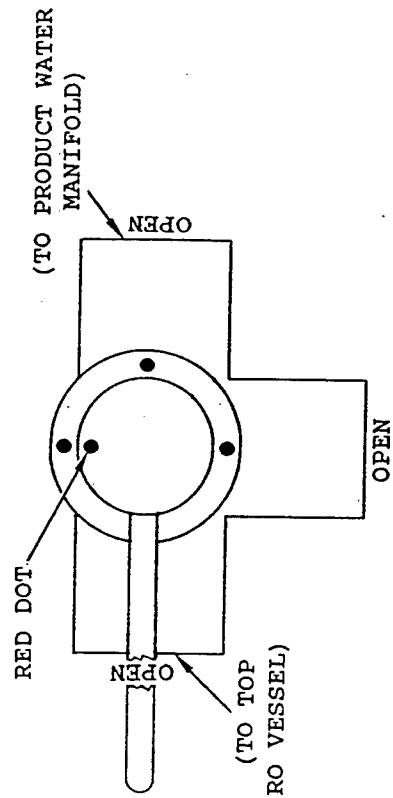
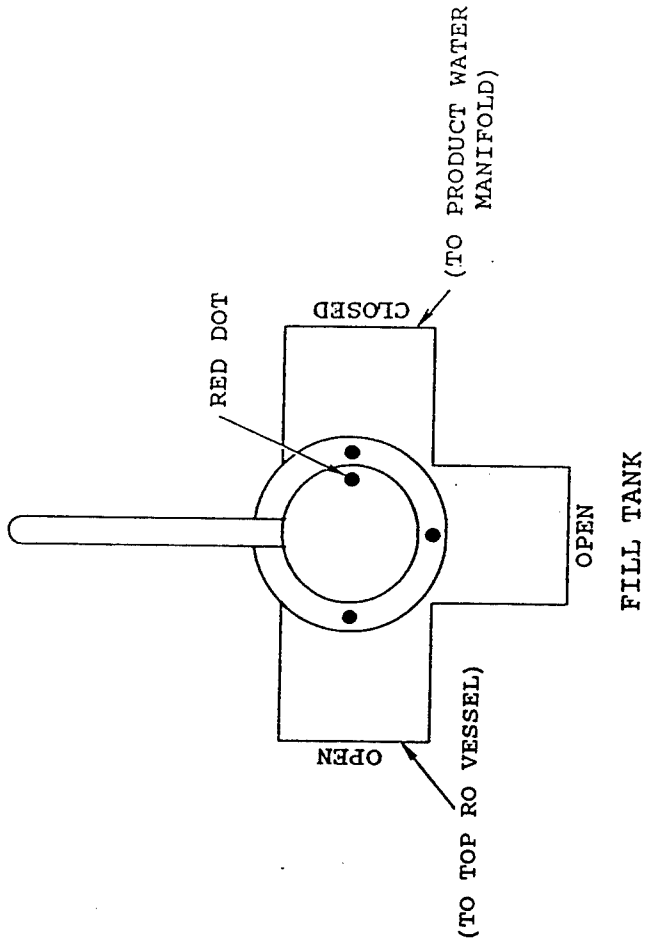

Figure 2-1. 3-Way Valve.



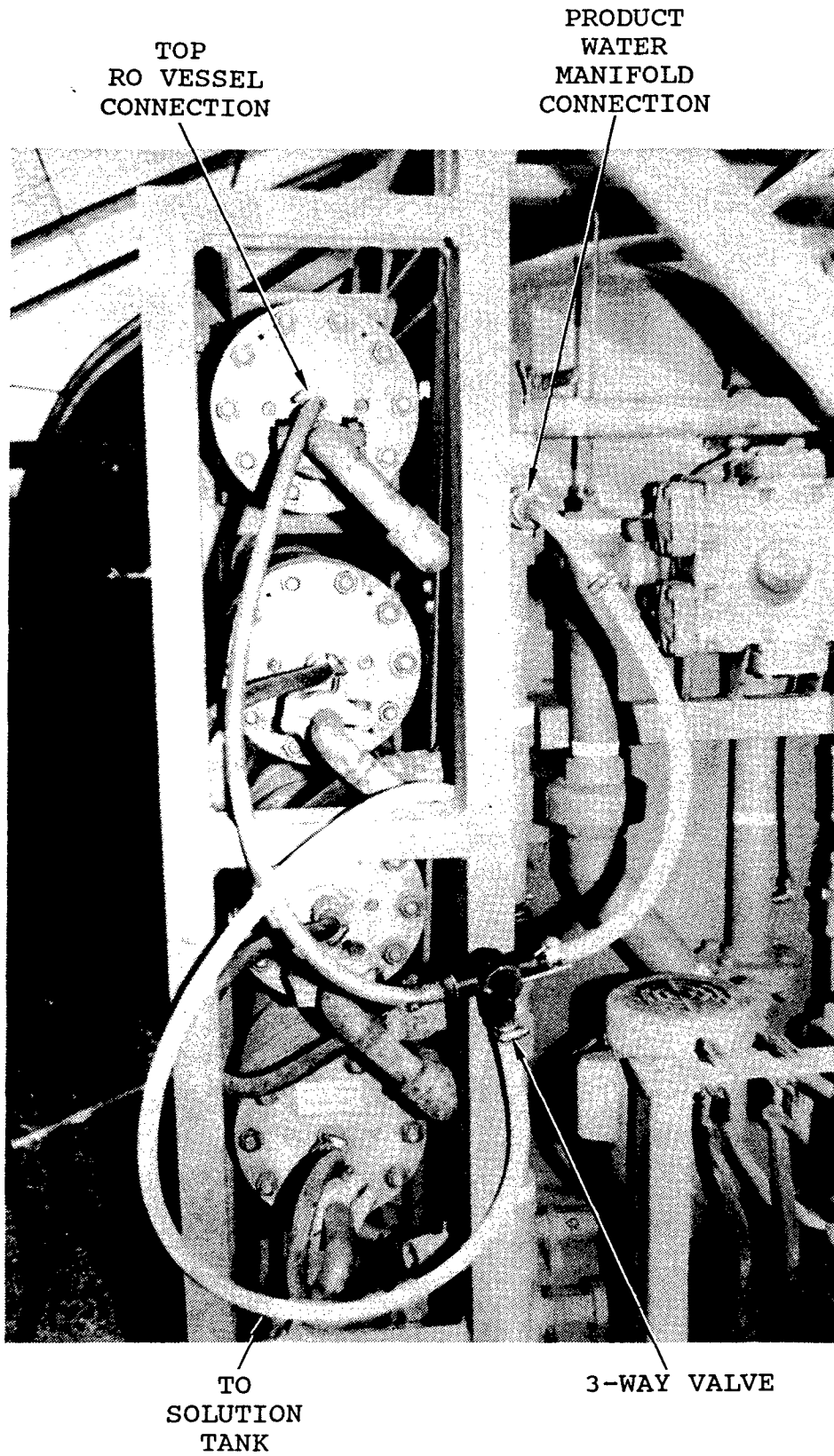

Figure 2-2. Installation of 3-Way Valve.

- b. Position the tubing attached to the 3-way valve branch so that its end is hanging inside the solution tank. This will allow a supply of unchlorinated product water to flow into the tank when the 3-way valve is in the fill tank position. This water is used to batch the cleaning solution.
- c. During normal ROWPU operation keep the 3-way valve positioned so that the red dot is located at the branch of the valve as shown in figure 2-1.

2-0.1.4 Filling the Solution Tank.

CAUTION

Use of CHLORINATED water during operation, cleaning or preservation procedures will cause permanent damage to the reverse osmosis elements.

- a. Connect the 1-1/2 inch valve to the 1-1/2 inch nipple at the bottom of the tank. Use teflon tape to ensure a leak-proof joint. Close the valve.

Note

Before filling the solution tank, ensure that all components have been removed from the stainless steel solution tank.

- b. Prior to the shutdown of the ROWPU, rotate the valve handle so that the red dot is at the outlet of the valve "run" leading to the product water manifold, refer to figure 2-1. This will divert unchlorinated product water to the branch outlet and into the solution tank.
- c. When the water level in the solution tank reaches the bottom of the upper hose connection (approximately 40 gallons),



reposition the 3-way valve to the normal ROWPU location so that the red dot is at the branch outlet of the valve, as shown in figure 2-1. This will allow water produced by the ROWPU to enter the product water manifold.

WARNING

High voltages are used in the operation of this equipment. Death on contact may result if personnel fail to observe safety precautions.

2-0.1.5 Preparation of Cleaning Solution. Before cleaning the RO elements, the equipment must be connected together and the cleaning solution prepared in the stainless steel tank.

- a. Connect ROWPU raw water pump to solution tank, utilizing the pump inlet hose adapter and the 1-1/2 inch by 3 foot long suction hose with quick disconnect fittings as shown in figure 2-3.

Note

Before proceeding with the next step, ensure that raw water pump No. 2 toggle switch is in the "STOP" position.

- b. Connect the power cord from the raw water pump to the receptacle on the front panel of the ROWPU marked "Raw Water Pump No. 2."
- c. Attach the heater/strainer piping assembly to the hose connection at the discharge of the pump as depicted in figure 2-4.



SOLUTION TANK

1" HOSE CONNECTION

1 1/2" VALVE

1 1/2" SUCTION HOSE

PUMP INLET HOSE ADAPTER

RAW WATER PUMP

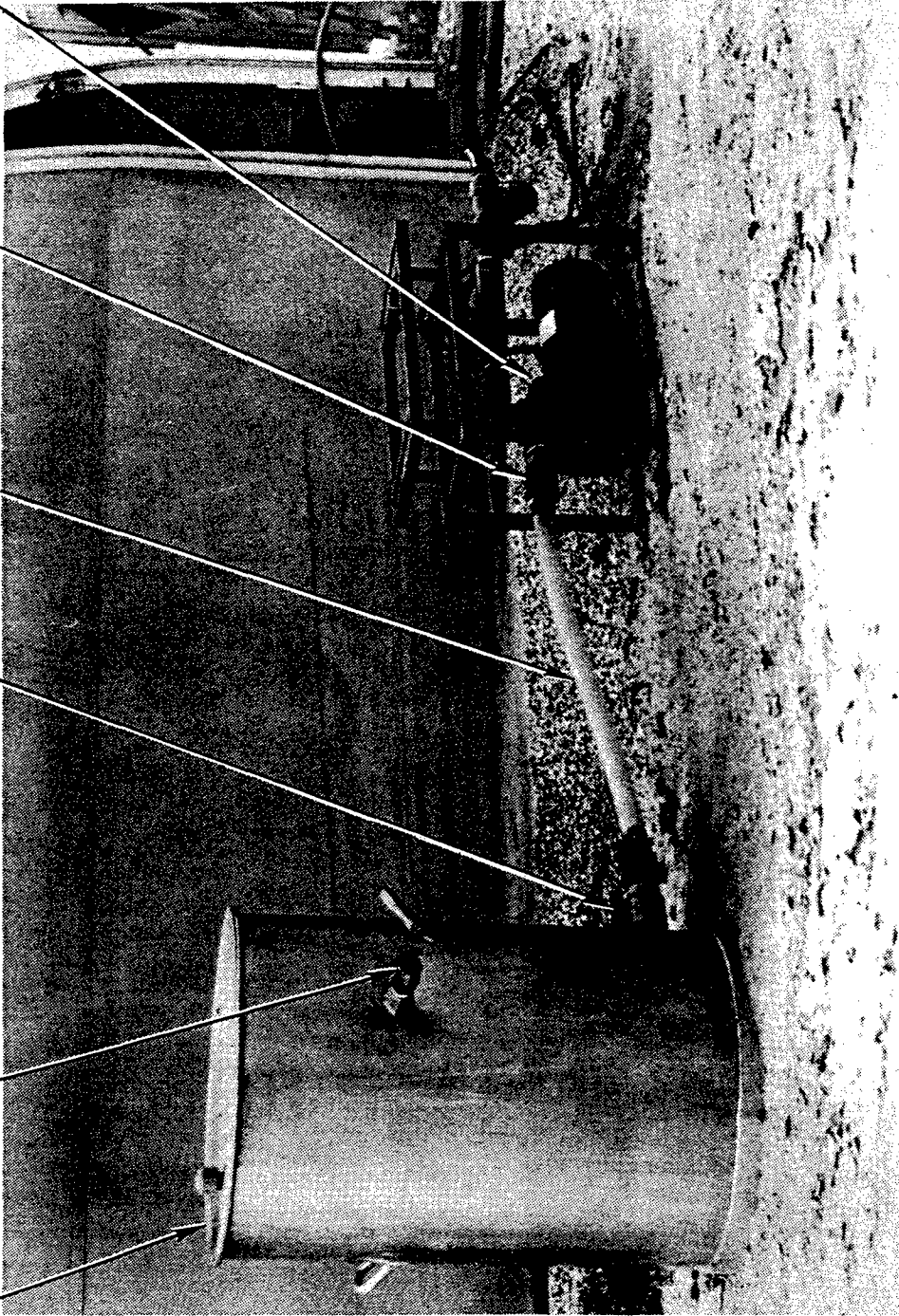

Figure 2-3. Solution Tank and Raw Water Pump Installation.



HEATER AND PUMP
ELECTRICAL
CABLES

HEATER
STRAINER

HEATER

PUMP
DISCHARGE

RAW WATER
PUMP

1 1/2" SUCTION
HOSE

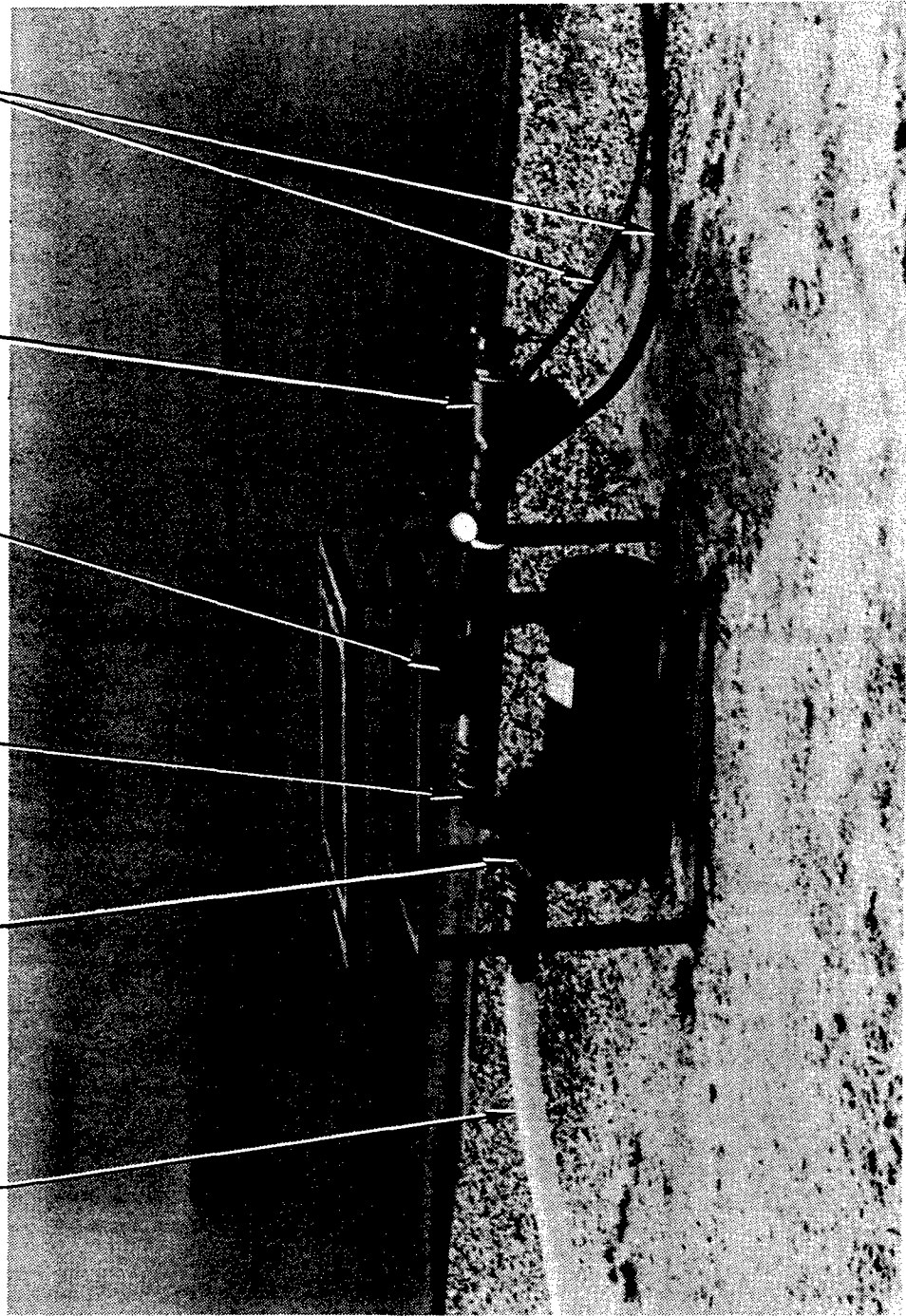

Figure 2-4. Heater and Strainer Installation.



- d. Connect one end of the 1 inch by 11 foot hose to the discharge of the heater/strainer assembly.
- e. Connect the 1 inch valve with quick disconnects on the opposite end of the hose.
- f. Connect the 1 inch valve attached to the hose to the 1 inch connection on the side of the solution tank. Completed hook up is depicted in figure 2-5.
- g. Ensure element cleaning switch located on the left side of the ROWPU is in the "OFF" position as shown in figure 2-6.
- h. Connect the electrical cord from the heater to the backwash pump receptacle at the front panel of the ROWPU.

WARNING

Avoid contact with chemicals either in dry form or when mixed with water. If chemicals should come in contact with exposed skin or enter the eye(s), immediately wash with fresh water and seek medical attention.

CAUTION

Do not add more cleaning solution than the premeasured amount. Permanent damage to the reverse osmosis elements will occur if excessive cleaner is used.

Note

Tank must be filled to the bottom of the one inch connection with clean unchlorinated water before proceeding with the next step.

- i. Add the required amount of cleaning powder to the unchlorinated product water in the tank.



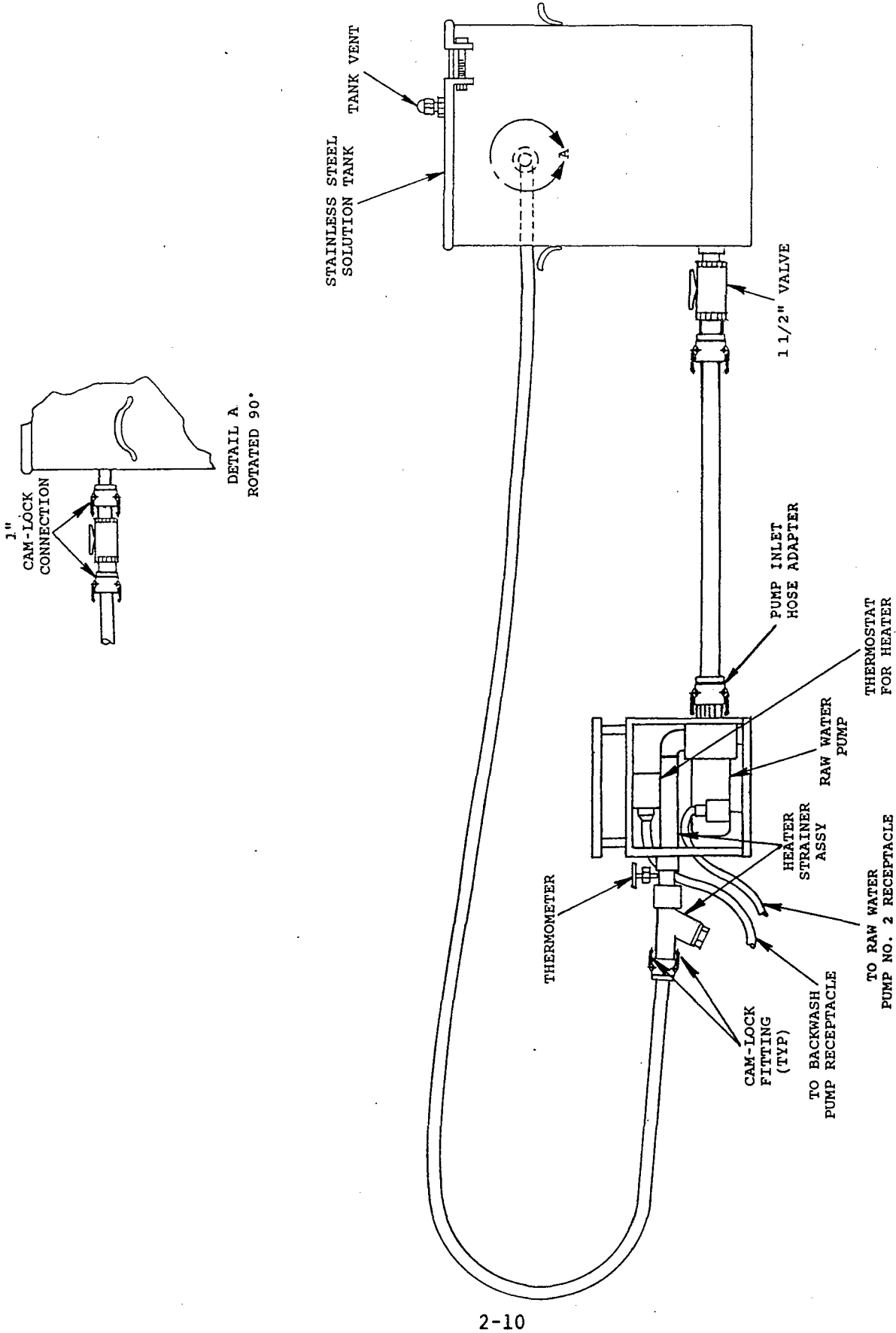

2-10

Figure 2-5. Mixing Cleaning Solution, Pump and Tank Configuration.



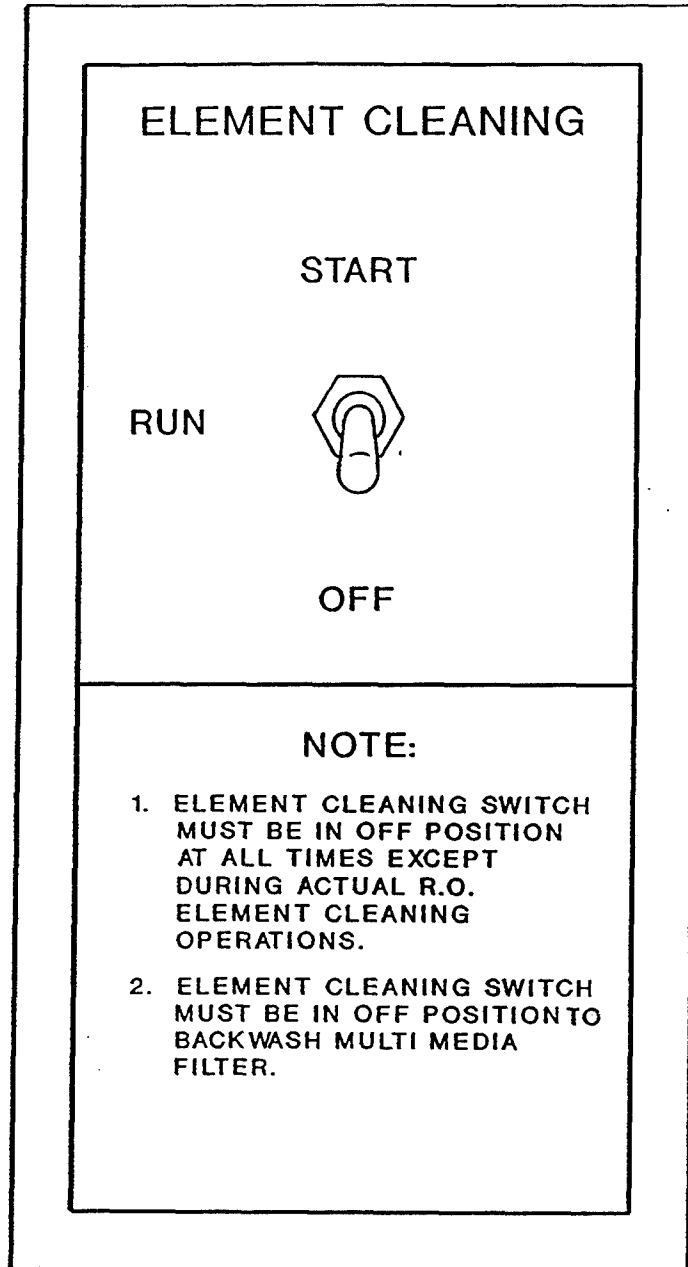

Figure 2-6. Element Cleaning Switch.

- j. Place the cover on the tank so the cleaning solution will not splash out of the tank during mixing.

Note

If the cleaning solution is 60°F at the start of the mixing procedure, it will take approximately 30 minutes for the solution to reach a temperature of 80°F.

- k. Turn raw water pump No. 2 toggle switch to the "START" position. The raw water pump will start. This will circulate the unchlorinated water and cleaning powder within the tank, mixing the cleaning powder and water.

CAUTION

Do not operate heater without solution circulating through the heater assembly.

- l. Place the element cleaning switch to the "START" position, then allow switch to reposition itself to the "RUN" position. This will energize a red light on the thermostat, indicating the heater is on.

Note

Mixing of the cleaning solution may require the use of a paddle to breakup the solids that settle to the bottom of the solution tank.

- m. After the solution has been thoroughly mixed and heated to 80° F, place the element cleaning switch in the "OFF" position and then turn off raw water pump No. 2. The ROWPU can now be shutdown and prepared for cleaning.



2-0.2

Preparation of ROWPU for Cleaning. After the ROWPU has been shutdown, it must be prepared for cleaning.

- a. Drain the element vessels by opening the element vessel drain valve, the drain product water valve and the product water vent valve. These valves are depicted in figure 2-7.
- b. Allow the vessels to drain for a minimum of 10 minutes.
- c. Disconnect the victaulic connectors on the upper vessel inlet connection and lower vessel outlet connection.
- d. Carefully loosen the Swagelok connections on the piping leading to the victaulic connectors and rotate the pipes away from the vessel connectors.

CAUTION

Do not pressurize the ROWPU with product water outlet capped. This could cause permanent damage to the ROWPU.

- e. Cap the product water outlet located at the front panel of the ROWPU as shown in figure 2-8.
- f. Attach the victaulic half of the valve adapter assembly with the elbow, to the top RO vessel as depicted in figure 2-9.
- g. Attach the other valve adapter assembly to the bottom RO vessel as depicted in figure 2-10.
- h. Connect the vessel discharge, tank return tubing to the valve adapter at the bottom RO vessel.



PRODUCT WATER
VENT VALVE

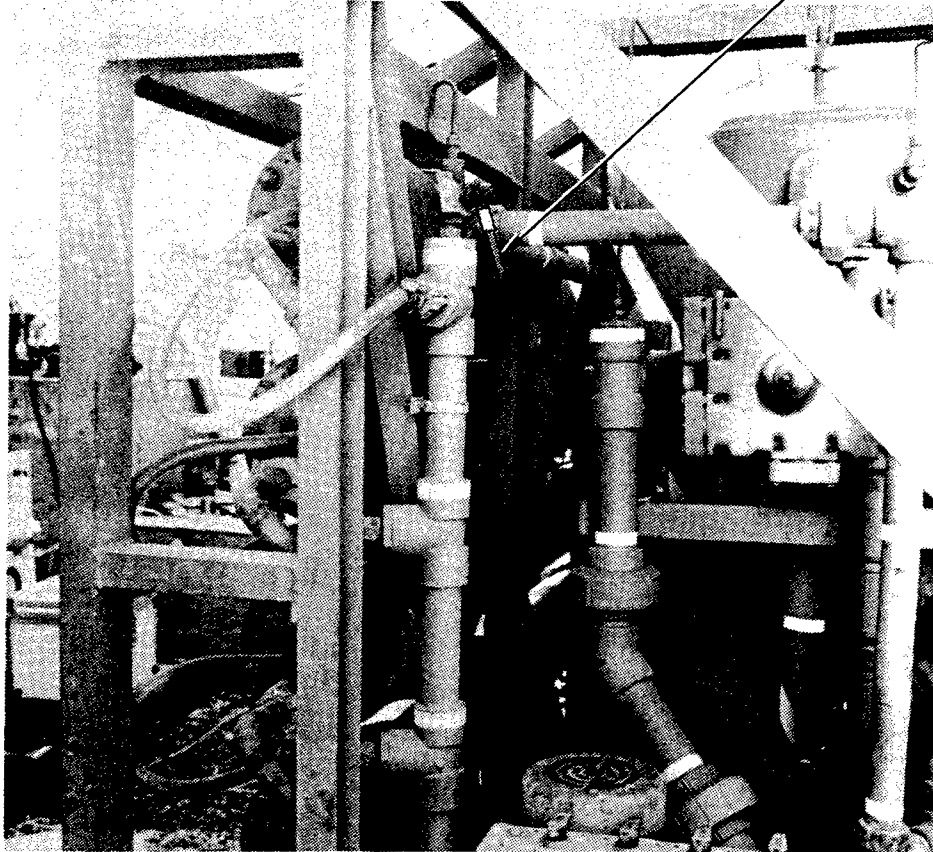

PRODUCT
WATER
DRAIN
VALVE

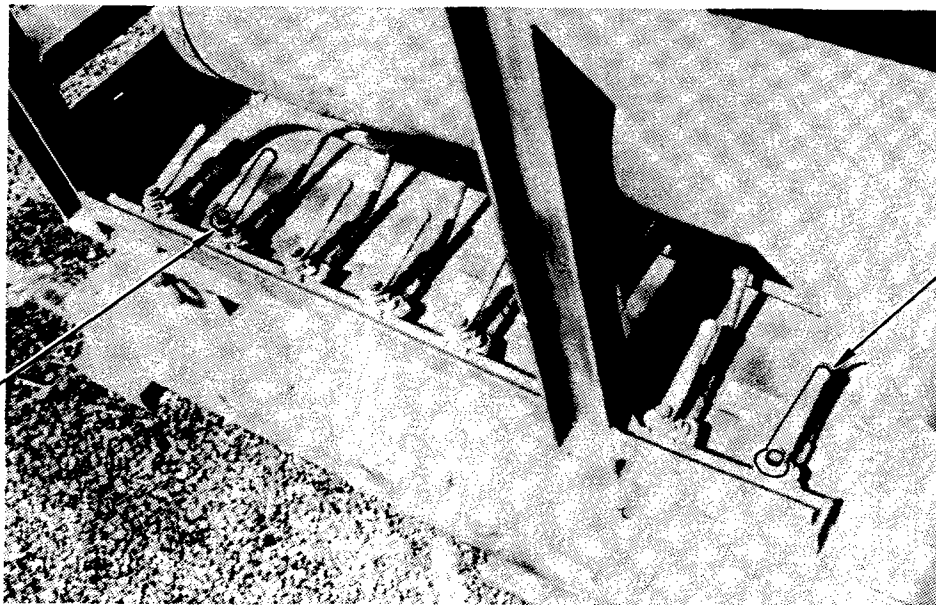

VESSEL
DRAIN
VALVE

Figure 2-7. Element Vessel, Product Water Drain and Vent Valves.

PRODUCT
WATER OUTLET
"CAPPED"

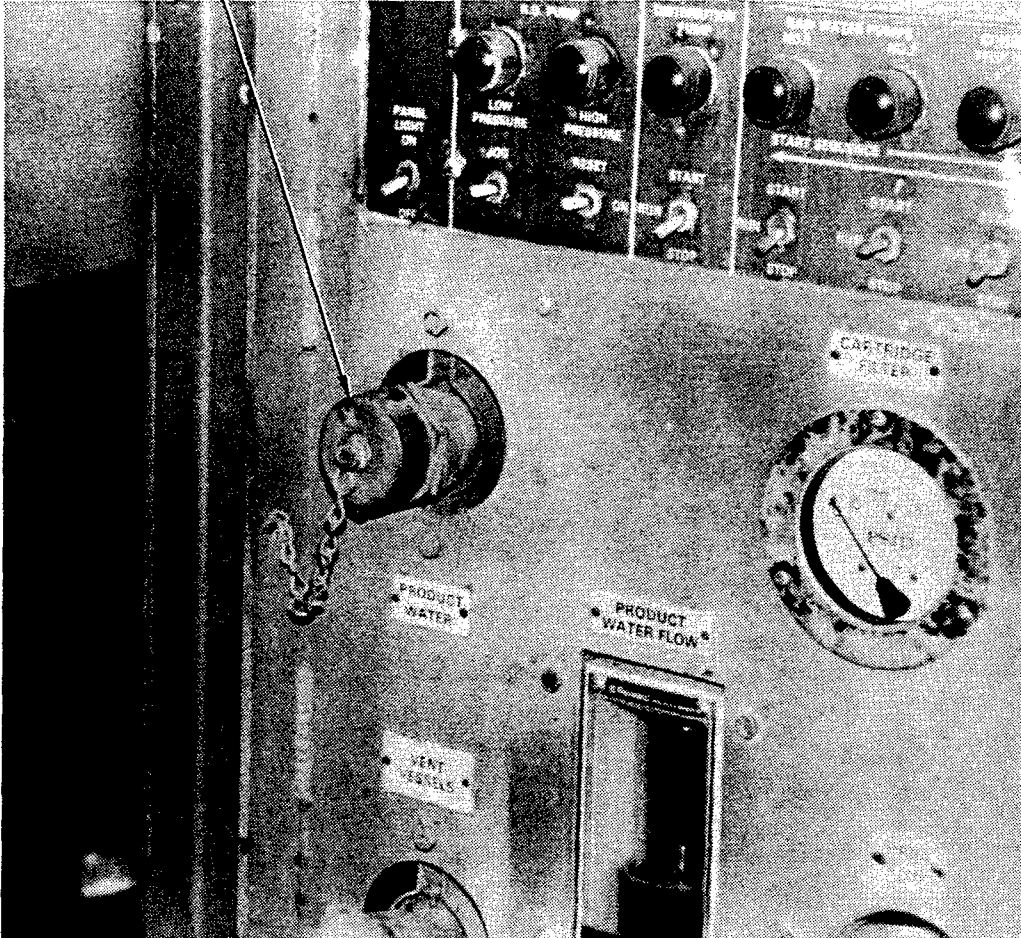
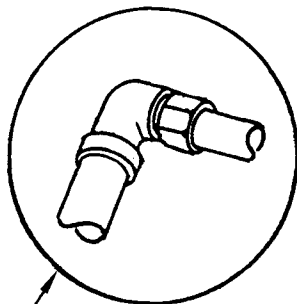
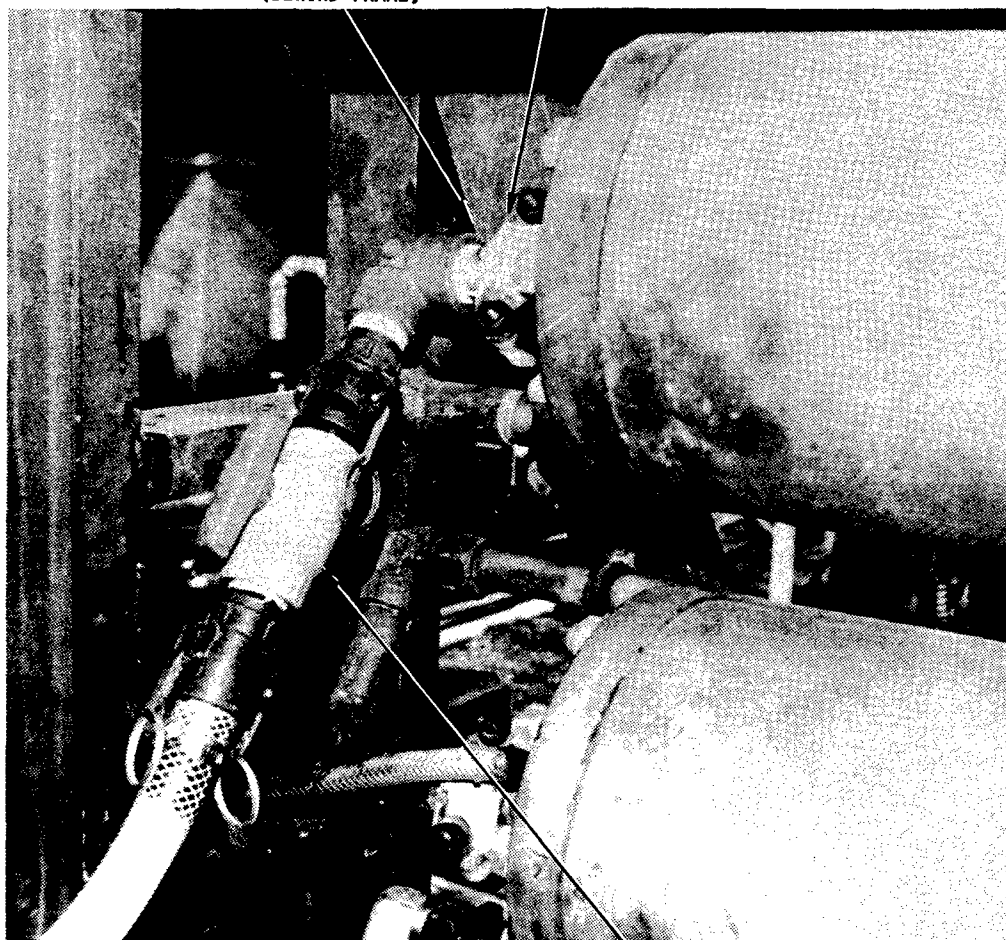

Figure 2-8. Product Water Outlet.



SWAGELOK
CONNECTOR
(BEHIND FRAME)

VICTAULIC
COUPLING



VESSEL INLET
VALVE ADAPTER
ASSEMBLY

Figure 2-9. Valve and Victaulic Coupling, Top RO Vessel.

BOTTOM
RO VESSEL

VICTAULIC
COUPLING

VESSEL OUTLET VALVE
ADAPTER ASSEMBLY

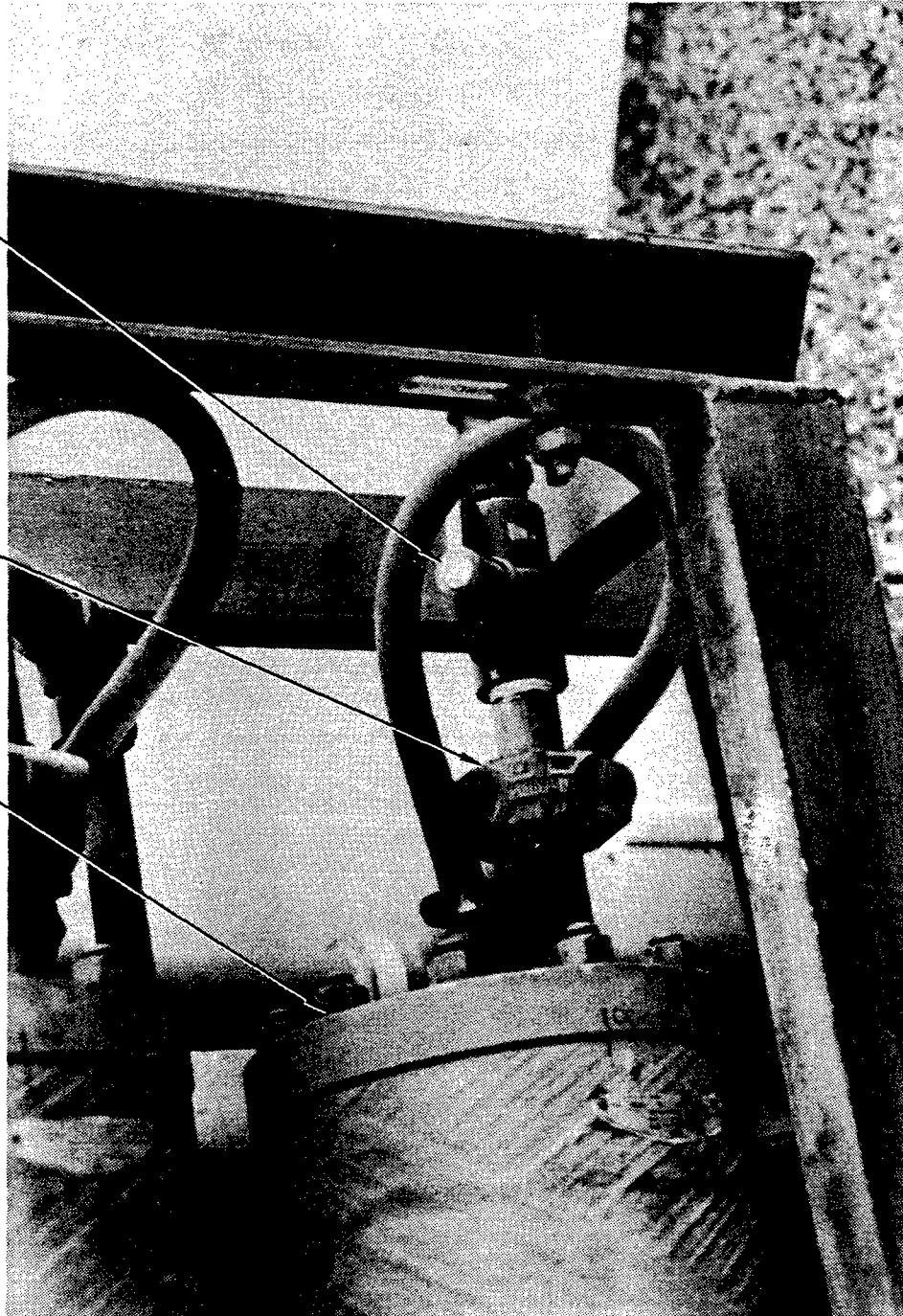

Figure 2-10. Valve Adapter Assembly Attached to Bottom RO Vessel.

- i. Connect the product water collection tubing to the tee connection in the tank return line previously installed.

The completion of steps g through i are depicted in figure 2-11.

2-0.3

Cleaning of RO Elements. Perform the following procedures to clean the RO elements after the cleaning solution is mixed and has been heated to 80°F.

- a. Close the product water drain valve (figure 2-7) on the ROWPU.
- b. Turn the 1 inch valve located at the top of the tank to the closed position.
- c. Disconnect the 1 inch valve at the connection between the valve and the tank, and attach it to the inlet at the top RO vessel as shown in figure 2-9. Open the valve.
- d. Place the valve at the bottom RO vessel to the fully open position.
- e. Rotate the 3-way valve to the element cleaning position as depicted in figure 2-1.
- f. Connect the hose from the bottom RO vessel (discharge) to the 1 inch connection located near the top of the solution tank as shown in figure 2-11.
- g. Turn raw water pump No. 2 switch (figure 2-12) to the "START" position.
- h. Close the vent on the product water manifold (figure 2-7) after all air has been vented from the vessels. At this time, the cleaning solution is circulating through the RO vessels.





Figure 2-11. Connection of Bottom RO Vessel, Tee, 3-Way Valve and Solution Tank.



CAUTION

Do not allow chemical solution to exceed 80°F. If the chemical solution exceeds this temperature, permanent damage to the reverse osmosis elements will occur.

- i. Cleaning should be performed for 45 minutes. After cleaning, de-energize the raw water pump by placing the switch marked "raw water pump No. 2" to the "STOP" position.

WARNING

During training exercises, the cleaning solution should be transferred to a 55 gallon waste drum and disposed of in accordance with local, state, and federal regulations. During combat operations, the cleaning solution should be disposed of as far from the ROWPU site as possible to reduce the risk of contaminating the feedwater supply for the ROWPU's.

2-0.4 Disposal of Cleaning Solution. If the cleaning solution does not appear dirty it can be used to clean additional ROWPU's. However, to dispose of the cleaning solution, the following procedures should be followed:

- a. Close both the 1-1/2 inch valve at the bottom of the solution tank and the 1 inch valve located at the top RO vessel valve adapter.
- b. Disconnect the 1 inch by 11 foot long plastic hose with the valve from the top RO vessel valve adapter and rotate the adapter with the elbow upwards.
- c. By means of gravity flow, allow the cleaning solution to drain from the RO vessels back into the solution tank.



- d. Move the unconnected end of the 11 foot plastic hose section to a 55 gallon waste drum or the disposal location.
- e. Open the 1-1/2 inch valve located at the bottom of the solution tank and the 1 inch valve at the end of the 11 foot plastic hose.
- f. Secure the end of the 11 foot hose before energizing the raw water pump.

WARNING

Contact with cleaning solution may cause skin irritation or blistering. Avoid contact by using rubber gloves, and plastic face mask with goggles. Wash any exposed areas immediately with fresh clean water.

- g. Energize raw water pump No. 2, and run the raw water pump until the solution tank and the RO vessels are drained and empty.
- h. Turn the raw water pump switch No. 2 to the "STOP" position and open the product water drain valve.
- i. Pour any cleaning solution left in the solution tank or vessels into buckets and dispose of it at the designated site.

WARNING

Product water produced by the ROWPU for the first 30 minutes of operation following cleaning should be dumped to a waste location.

CAUTION

Ensure that the cap previously installed on the product water outlet located on the front of the ROWPU is removed prior to returning the ROWPU to normal operation. Failure to do this will result in damage to the ROWPU.

Note

The ROECPS components and the raw water pump should be rinsed thoroughly with product water prior to storage.

- 2-1. PRESERVATION PROCEDURE. Cleaning of the RO elements removes contaminants which have fouled the membrane. Preservation of the RO elements is performed following cleaning and is necessary to prevent microbial growth within the RO elements during storage of the ROWPU. If microbial growth occurs within the RO elements it will drastically reduce product flows and increase product TDS. Therefore, to maintain the ROWPU in an operational state during storage, preservation should be performed if the ROWPU is not operated for periods of two weeks or longer.

- 2-1.1 Preservation Configuration. For preservation, the configuration of the hoses, pump, and solution tank are identical to the cleaning configuration for both the mixing and recirculation procedure. The preservative recirculation configuration is shown in figure 2-13. Orientation from the solution tank 1-1/2 inch outlet located at the bottom of the tank should be the following:

- a. 1-1/2 inch valve.
- b. 3 foot length of 1-1/2 inch suction hose.
- c. Raw water pump with pump inlet adapter.
- d. Heater/strainer piping assembly.
- e. 11 foot by 1 inch hose with valve connected to the top RO vessel.
- f. 1 inch return hose with valve connected from bottom RO vessel to the tee.



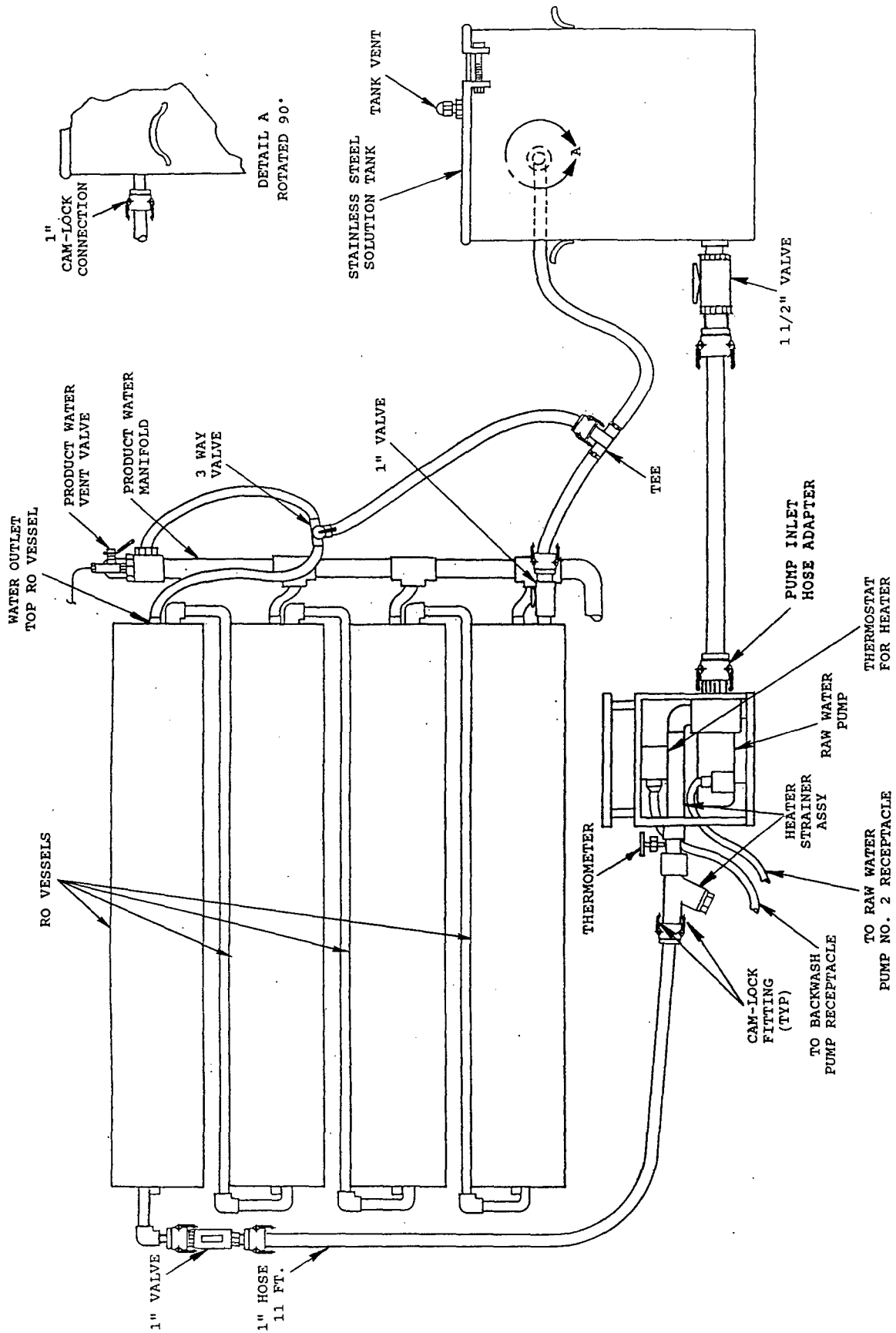

Figure 2-13. Preservation/Cleaning Configuration.



- g. 3-way valve is connected between the product water manifold and product water outlet of top RO vessel. Quick disconnect is connected to tee in tank return hose. 3-way valve is positioned so that all three ports are open as depicted in figure 2-1.

2-1.2 Mixing of Solution. Perform the following procedures to mix the preservative solution.

- a. Fill the solution tank with unchlorinated product water to the bottom of the 1 inch connector (approximately 40 gal.).
- b. Add the required amount of preservative to the solution tank.
- c. Recirculate solution with components connected in the tank mixing configuration (see figure 2-5) to mix preservative.

Note

Do not heat the preservative solution.

2-1.3 Circulation of Preservative Solution. Perform the following procedures to circulate preservative solution.

- a. Connect components as shown in figure 2-13, the preservative recirculation configuration.
- b. Install a cap on the product water outlet port located at the front panel of the ROWPU as shown in figure 2-8.
- c. Open all ROECPS valves and energize raw water pump No. 2 to circulate preservative solution.
- d. Vent air from product water manifold and allow the preservative to circulate through the vessels for 30 minutes.



e. . After 30 minutes, turn off the raw water pump.

2-1.4 Extended Storage of Reverse Osmosis Elements. The preservative solution should remain in the RO vessels to provide protection against microbial growth. If the ROWPU is to be stored in a freezing environment, the solution must be drained from the RO vessels. To retain the preservative in the RO vessels, close the valve on the bottom valve adapter assembly and install a quick disconnect cap. Also, remove the 1 inch valve at the inlet of the top RO vessel and install a quick disconnect cap on the valve adapter assembly.

2.2 USE OF RO VESSEL BYPASS LINE. The RO vessel bypass line provides the ROWPU operator a means of flushing the ROWPU with tap water as well as a means of checking ROWPU operation during Quarterly Preventive Maintenance. The bypass line allows raw water flow through the ROWPU to bypass the RO vessels, yet circulate through all piping components. This will flush residual seawater from the ROWPU components and prevent corrosion during storage of the ROWPU.

2.2.1 Installation of Bypass Line. Perform the following procedures to install the bypass line shown in figure 2-14.

- a. Remove victaulic connection at inlet of top RO vessel and outlet of bottom RO vessel.
- b. Install victaulic by male quick disconnect adapters to the non-vessel side of the victaulic connections previously removed in step a, as shown in figures 2-15 and 2-16.
- c. Install 12 foot by 1 inch tubing with female quick disconnects between the two male quick disconnects installed in step b.



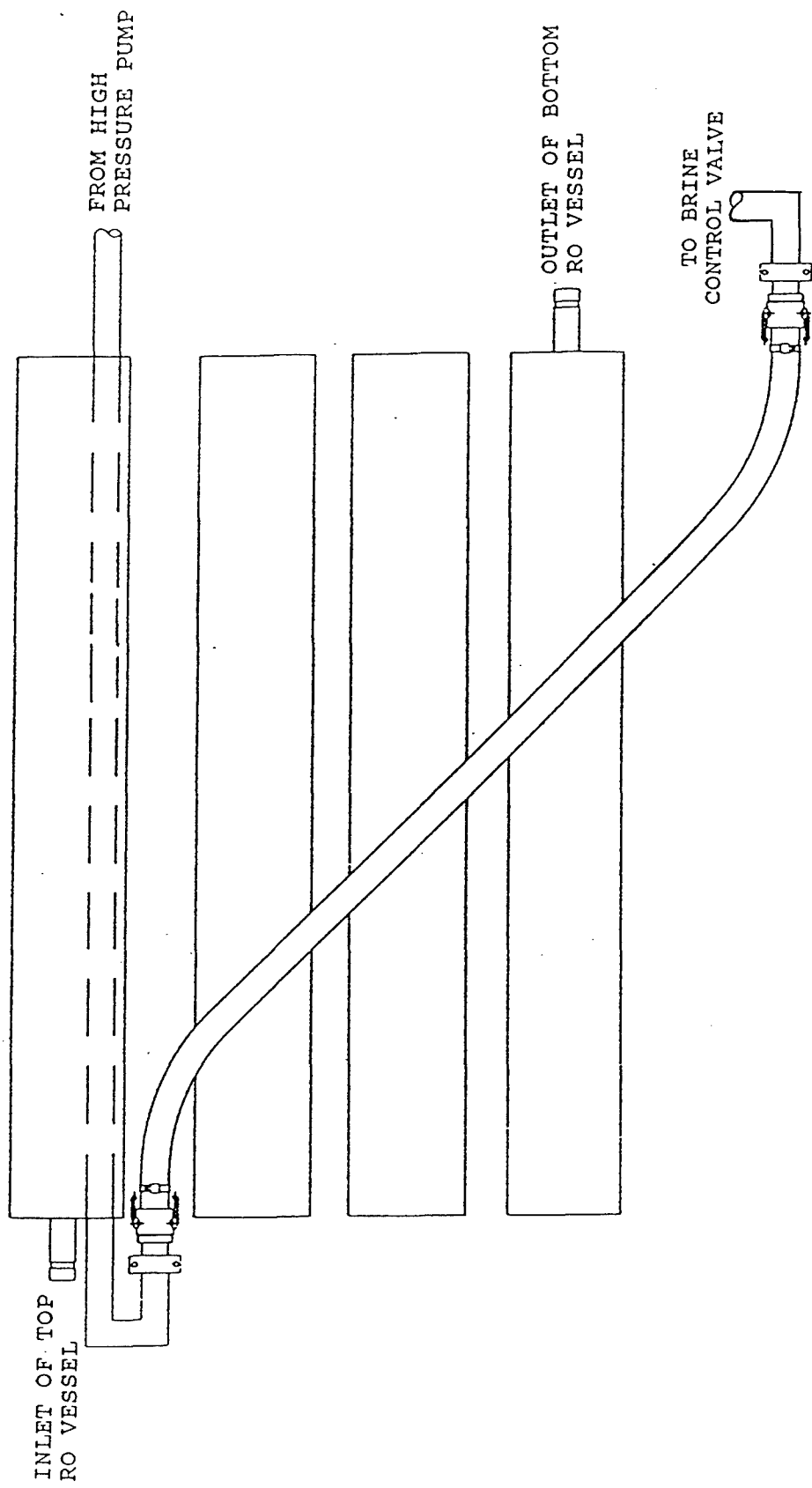
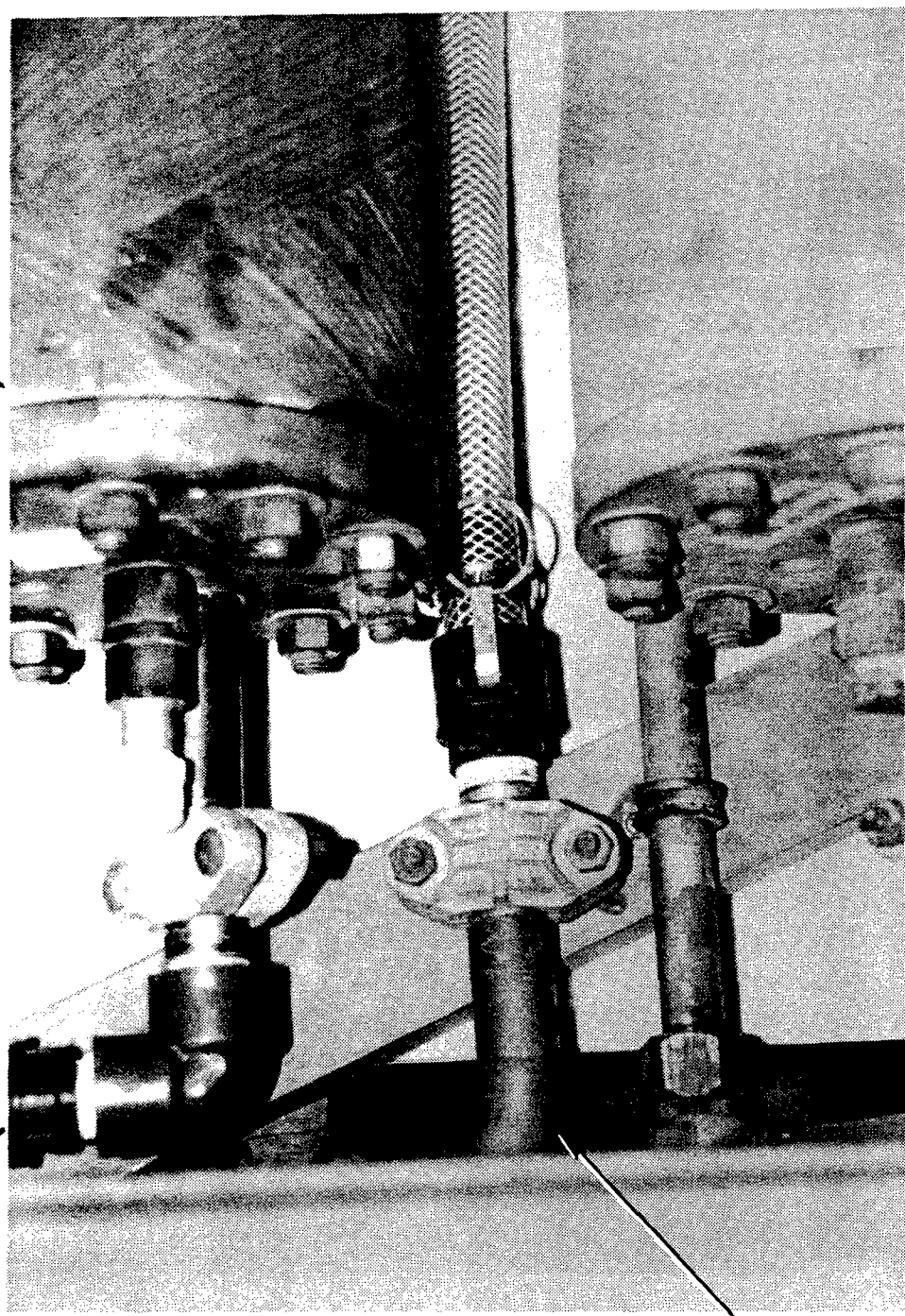

Figure 2-14. Installation of Bypass Line.



INLET OF TOP
RO VESSEL

TOP RO VESSEL



FROM
HIGH
PRESSURE
PUMP

Figure 2-15. Victaulic Connection to Quick Disconnect,
Top RO Vessel.



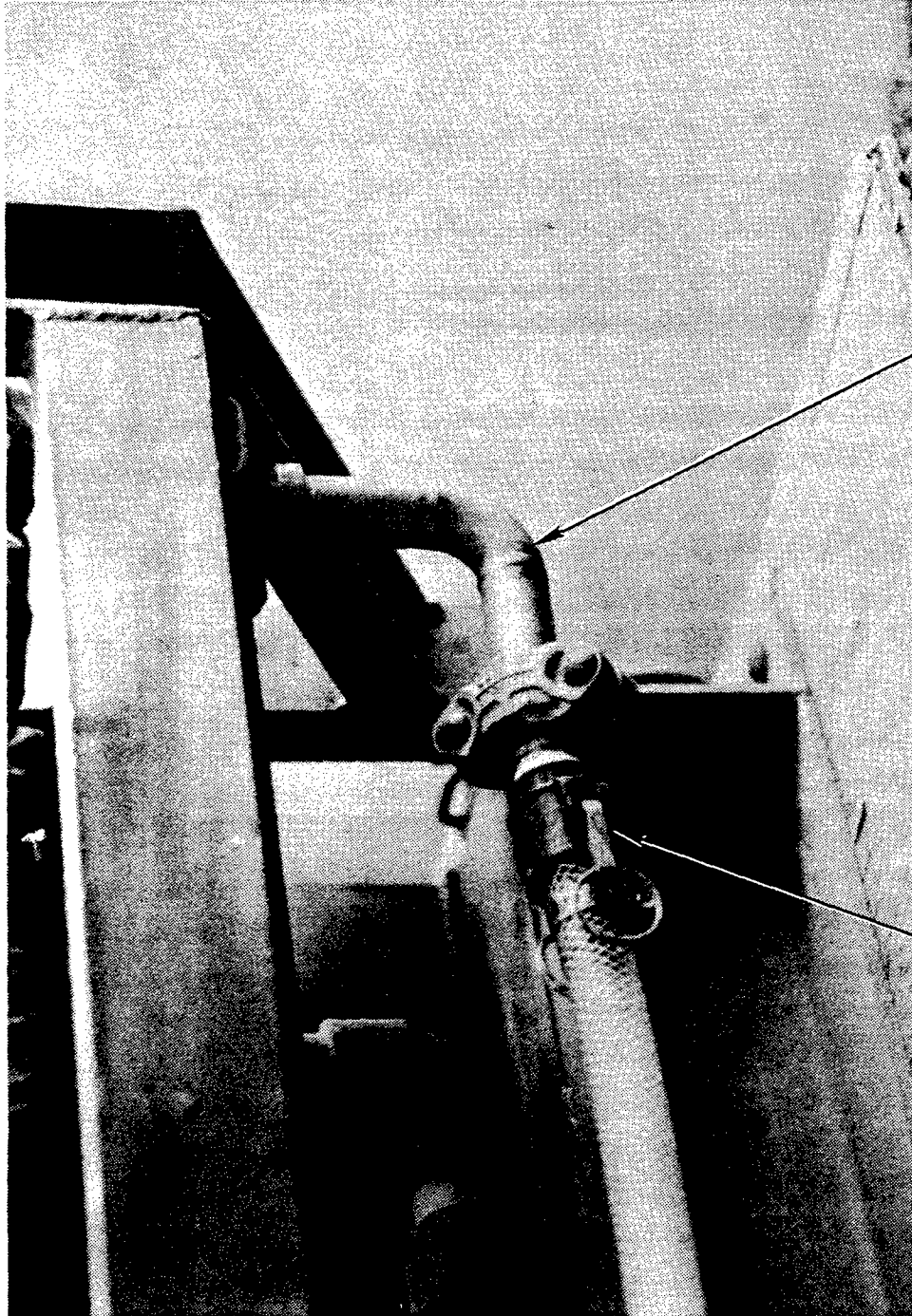

1" HOSE
AND COUPLING

TO BRINE
CONTROL VALVE

Figure 2-16. Victaulic Connection to Quick Disconnect,
Bottom RO Vessel.



CHAPTER 3

MAINTENANCE INSTRUCTIONS

WARNING

Equipment circuits contain high voltage when in operation. Do not attempt inspection or maintenance while equipment is connected to power source. Failure to do so may result in injury or death to personnel.

- 3-0. . MAINTENANCE DEFINITIONS. Maintenance is the action taken to retain material in, or restore material to serviceable condition. Maintenance will include the following areas, as defined.
- 3-0.1 Service. To clean, to preserve, and replenish.
- 3-0.2 Adjust. To regulate periodically in order to prevent malfunction.
- 3-0.3 Inspect. To verify serviceability and to detect imminent mechanical failure by scrutiny.
- 3-0.4 Test. To verify serviceability and to detect imminent electrical failure by use of special equipment.
- 3-0.5 Replace. To substitute serviceable assemblies, subassemblies, and parts for unserviceable components.
- 3-0.6 IROAN. Inspect and Repair Only as Necessary (IROAN) is the maintenance technique that determines the minimum repairs necessary to store equipment, components, or assemblies to prescribed maintenance serviceability standards by using all available



diagnostic equipment and test procedures, and by minimizing disassembly and parts replacement. IROAN is applicable to all categories of maintenance.

3-0.7 Repair. To restore that which is unserviceable condition by adjusting or replacing damaged or unserviceable parts, components, or assemblies.

3-1. FORMS, RECORDS, AND REPORTS. Refer to TM 4700-15/1.

3-2. GENERAL. This section provides information on specific tools and equipment required to perform maintenance.

3-3. TOOLS AND MATERIAL CARRIED WITH THE EQUIPMENT. ROECPS uses standard hand tools. No tools, equipment, or repair parts are provided with the equipment.

3-4. PREVENTIVE MAINTENANCE. Preventive Maintenance is limited to the following components defined below.

3-4.1 Hose Sections. Inspect all hose sections thoroughly. Look for cracks, crushed sections, broken fittings, missing or damaged gaskets, missing hose clamps and hose damage near the fittings. Make sure no gravel or debris is inside hose sections. Rinse with clean, unchlorinated water prior to and following use.

3-4.2 Threaded Pipe and Hose Fittings. Inspect all threaded fittings on the heater assembly, strainer, and the vessel inlet and outlet assemblies to make sure they are tight and have been sealed using teflon antiseize tape. Threaded hose type fittings and quick disconnect fittings should be inspected to make sure they have gaskets installed.



Note

Do not over tighten plastic fittings as they may break.

- 3-4.3 Valves. Inspect all valves to ensure they turn freely from the fully open to the fully closed position.
- 3-4.4 Victaulic Couplings and Grooved Fittings. Inspect victaulic couplings for damaged or missing bolts, nuts or gaskets. Inspect all sealing faces near the groove on the vessel inlet and outlet adapters to make sure the sealing faces are not damaged.
- 3-4.5 Cleaning Tank Assembly. Inspect cleaning tank assembly for punctures and cracks at welded inlet and outlet fittings. Make sure threads for the fittings have not been damaged. Make sure the vent is in the open position prior to use. Check the condition of the tank gasket and band clamp to be sure it functions properly. Make sure the hose assembly which directs the tank return flow downward is installed. Clean inside of tank with unchlorinated product water prior to and following use, to remove any dust or dirt.
- 3-4.6 Heater Assembly. Inspect heater to make sure the electrical cord is firmly attached to the junction box. Make sure that the junction box cover is watertight and that the junction box is firmly attached to the heater. Ensure that the indicator light is not broken. Look inside heater assembly to ensure elements and thermowell sensor are intact and do not wiggle. Check electrical cord and connector for damage.
- 3-4.7 Thermometer. Inspect thermometer to make sure glass is not broken and that the indicated temperature is accurate. Make sure thermometer connection is tight and will not leak.



3-4.8 Y-Strainer. Inspect screen inside Y-strainer and clean if necessary. Make sure O-ring is intact and not damaged.



CHAPTER 4

TROUBLESHOOTING

- 4-0. INTRODUCTION. The purpose of this chapter is to present troubleshooting procedures for the ROECPS. Troubleshooting is the process of locating the cause of trouble so repairs can be made. The operator shall be responsible for an important phase of troubleshooting. The most valuable piece of troubleshooting equipment are the eyes and ears of the operator. The slightest variation in equipment sound or appearance from normal operating conditions should alert the operator to potential problems. Troubleshooting by the operator is preventive in nature since proper action at the first warning will prevent complete failure and extensive damage. A secondary, but equally important aspect of troubleshooting is the accurate reporting of symptoms so that maintenance personnel responsible for the equipment can diagnose, isolate, and correct the trouble with the least possible delay.
- 4-1. TROUBLESHOOTING PROCEDURES. Refer to table 4-1. The table provides maintenance personnel a way to isolate malfunctions to a replaceable/ repairable component. The troubleshooting chart indicates trouble, isolates probable cause, and provides a remedy to malfunctions that might occur during ROECPS equipment operation. Table 4-1 list the most common malfunctions that may occur, probable causes and the corrective actions to be taken. This manual cannot list all malfunctions that may occur, nor all probable causes and corrective actions. If a malfunction, probable cause is not listed or is not corrected by the listed corrective actions, notify the appropriate supervisor.



Table 4-1. ROECPs Troubleshooting

Problem	Probable Cause	Corrective Action
<p>1. Pump does not prime.</p>	<p>1. Check inlet and outlet ball valves.</p> <p>2. Check hoses for kinks and leaks.</p> <p>3. Check pump drains.</p> <p>4. Check inside of tank to make sure nothing is blocking the outlet port at the bottom of the tank.</p> <p>5. Check pump operation (see 600 gph ROWPU Operator's Manual).</p>	<p>1. Open valves.</p> <p>1. Remove kinks and repair leaks.</p> <p>1. Close drains.</p> <p>1. Remove any obstructions.</p> <p>1. Perform corrective actions designated in Operator's Manual.</p>
<p>2. Insufficient flow recirculation, less than 20 gpm.</p>	<p>1. Check all valves.</p> <p>2. Check Y-strainer.</p>	<p>1. Open all valves.</p> <p>1. Clean strainer.</p>



Table 4-1. ROECPS Troubleshooting (Continued)

Problem	Probable Cause	Corrective Action
<p>2. Insufficient flow recirculation, less than 20 gpm. (Continued)</p>	<p>3. Check position of 3-Way valve to make sure all flow is being returned to the tank.</p> <p>4. Check the cleanliness of cleaning solution. If elements are excessively dirty, then 20 gpm flow may not be achieved initially.</p> <p>5. Check pump operation (see 600 gph ROWPU Operator's Manual).</p>	<p>1. Position valve in element cleaning position.</p> <p>2. Make sure product water cap is installed.</p> <p>3. Check first RO element in the series to see if the end is plugged with debris.</p> <p>1. Continue cleaning procedures for 45 minutes to see if flow is restored.</p> <p>1. Perform corrective actions designated in Operator's Manual.</p>
<p>3. Heater does not turn on when temperatures are less than 78°F.</p>	<p>1. Check element cleaning switch to make sure it is in the "Start/Run" position.</p>	<p>1. Place switch in the correct position.</p>



Table 4-1. ROECPS Troubleshooting (Continued)

Problem	Probable Cause	Corrective Action
<p>3. Heater does not turn on when temperatures are less than 78°F. (Continued)</p>	<p>2. Check backwash pump breaker to be sure it is in the "ON" position.</p>	<p>1. Place breaker in the "ON" position.</p>
	<p>3. Check connector from the heater to backwash pump connector.</p>	<p>1. Tighten connector.</p>
	<p>4. Check setting on thermostat in heater junction box by removing the box cover and adjusting the thermostat to a lower temperature. Check to see if heater turns on.</p>	<p>1. Leave thermostat set at the lower setting and close the junction box.</p>
	<p>5. Check wires inside heater junction box to make sure the connections comply with drawing in the SL-3.</p>	<p>1. Make necessary corrections.</p>
	<p>6. Check heating element and thermocouple for noticeable physical damage.</p>	<p>1. Replace heater if necessary.</p>



Table 4-1. ROECPS Troubleshooting (Continued)

Problem	Probable Cause	Corrective Action
<p>3. Heater does not turn on when temperatures are less than 78°F. (Continued)</p>	<p>7. Check temperature using another gauge to verify the accuracy of the gauge on the ROECPS.</p>	<p>1. Replace temperature gauge if accuracy is off by more than two (2) degrees.</p>
<p>4. Heater does not turn off when temperatures are greater than 80° to 82° F.</p>	<p>1. Check setting on thermostat in heater junction box by removing the box cover and adjusting the thermostat to a lower temperature. Check to see if heater is on.</p> <p>2. Check wires inside heater junction box to make sure the connections comply with wiring schematic in the SL-3.</p> <p>3. Check thermocouple for noticeable physical damage.</p> <p>4. Check temperature using another gauge to verify the accuracy of the gauge on the ROECPS.</p>	<p>1. Leave thermostat set at lower setting and close up junction box.</p> <p>1. Make any necessary corrections.</p> <p>1. Replace heater if necessary.</p> <p>1. Replace temperature gauge if accuracy deviates more than 2° F from true reading.</p>



Table 4-1. ROECPS Troubleshooting (Continued)

Problem	Probable Cause	Corrective Action
<p>5. Cleaning or preservative powder does not fully dissolve during the mixing stage.</p>	<p>1. Check to insure that what appears to be not dissolved is in fact cleaner and not air bubbles by turning off pump briefly.</p> <p>2. Check recirculation flow to see if it is 20 gpm or more.</p> <p>3. Check water temperature. Higher temperatures will improve the dissolving of the cleaner and preservative solutions.</p> <p>4. Cleaning and preservative powder may be past the expiration date.</p>	<p>1.No corrective action if bubbles are present. Assist mixing using a paddle if some powder or chunks remain undissolved.</p> <p>1. See problem 2 if flow is less than 20 gpm.</p> <p>1. Set heater thermostat to correct temperature.</p> <p>1. Try a fresher batch of cleaner or preservative.</p>



APPENDIX A
GLOSSARY OF ABBREVIATIONS
AND ACRONYMS

Abbreviations/Acronyms	Definitions
CPVC	Chlorinated Polyvinyl Chloride
F	Fahrenheit
FT	Feet
GAL	Gallon
GPH	Gallons Per Hour
GPM	Gallons Per Minute
IROAN	Inspect & Repair Only as Necessary
KW	Kilowatts
NPSH	National Pipe Standard Hose
NPT	National Pipe Thread
PSI	Pounds Per Square Inch
PSIG	Pounds Per Square Inch Gauge
RO	Reverse Osmosis
ROECPS	Reverse Osmosis Element Cleaning and Preservation System
ROWPU	Reverse Osmosis Water Purification Unit
SL	Stock List
SS	Stainless Steel
TDS	Total Dissolved Solids
TM	Technical Manual
TYP	Typical

