

INNOVATIVE LINEAR RECIPROCATING MOTOR TECHNOLOGY FOR ADVANCED CRYOCOOLER SYSTEMS

Jeffrey C. Holliday

Hollidaylabs
Guysville, OH 45735

February 1994

Final Report

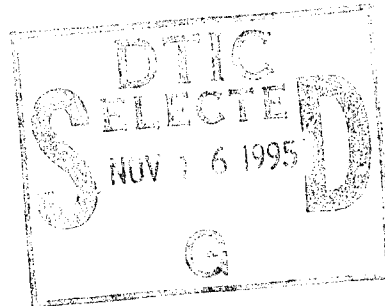

19951113 157

Distribution authorized to DoD components only; Proprietary Information; February 1994. Other requests for this document shall be referred to AFMC/STI.

WARNING - This document contains technical data whose export is restricted by the Arms Export Control Act (Title 22, U.S.C., Sec 2751 et seq.) or The Export Administration Act of 1979, as amended (Title 50, U.S.C., App. 2401, et seq.). Violations of these export laws are subject to severe criminal penalties. Disseminate IAW the provisions of DoD Directive 5230.25 and AFI 61-204.

DESTRUCTION NOTICE - For classified documents, follow the procedures in DoD 5200.22-M, Industrial Security Manual, Section II-19 or DoD 5200.1-R, Information Security Program Regulation, Chapter IX. For unclassified, limited documents, destroy by any method that will prevent disclosure of contents or reconstruction of the document.



PHILLIPS LABORATORY
Space and Missiles Technology Directorate
AIR FORCE MATERIEL COMMAND
KIRTLAND AIR FORCE BASE, NM 87117-5776

UNCLASSIFIED



AD NUMBER

AD- B 205 134

NEW LIMITATION CHANGE

TO

DISTRIBUTION STATEMENT A -
Approved for public release; Distri-
bution unlimited.

Limitation Code: 1

FROM

DISTRIBUTION STATEMENT -

Limitation Code:

AUTHORITY

J. Mosher, Phillips Lab, KAFB, N.M.

THIS PAGE IS UNCLASSIFIED

PL-TR-94-1036

This final report was prepared by Hollidaylabs, Guysville, OH, under Contract F29601-93-C-0086 Job Order, 9991SB1R, with Phillips Laboratory, Kirtland Air Force Base, New Mexico. The Laboratory Project Officer-in-Charge was Capt Jeffrey Wiese, (VTPT).

When Government drawings, specifications, or other data are used for any purpose other than in connection with a definitely Government-related procurement, the United States Government incurs no responsibility or any obligation whatsoever. The fact that the Government may have formulated or in any way supplied the said drawings, specifications, or other data, is not to be regarded by implication, or otherwise in any manner construed, as licensing the holder, or any other person or corporation; or as conveying any rights or permission to manufacture, use, or sell any patented invention that may in any way be related thereto.

This report has been authored by a contractor of the United States Government. Accordingly, the United States Government retains a nonexclusive royalty-free license to publish or reproduce the material contained herein, or allow others to do so, for the United States Government purposes.

This report contains proprietary information and shall not be either released outside the government, or used, duplicated or disclosed in whole or in part for manufacture or procurement, without the written permission of the contractor. This legend shall be marked on any reproduction hereof in whole or in part.

If your address has changed, if you wish to be removed from the mailing list, or if your organization no longer employs the addressee, please notify PL/VTPT, 3550 Aberdeen Ave SE, Kirtland AFB, NM 87117-5776 to help maintain a current mailing list.

This report has been reviewed and is approved for publication.

FOR THE COMMANDER

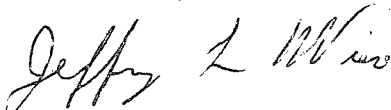

JEFFREY WIESE, Capt, USAF
Project Officer



DAVID KRISTENSEN, Lt Col, USAF
Chief, Space Power and Thermal
Management Division



HENRY L. PUGH, JR., Col, USAF
Director of Space and Missiles Technology

DO NOT RETURN COPIES OF THIS REPORT UNLESS CONTRACTUAL OBLIGATIONS OR NOTICE ON A SPECIFIC DOCUMENT REQUIRES THAT IT BE RETURNED.

DRAFT SF 298

1. Report Date (dd-mm-yy) February 1994	2. Report Type Final	3. Dates covered (from... to) 5-93 to 2-94			
4. Title & subtitle Innovative Linear Reciprocating Motor Technology for Advanced Cryocooler Systems		5a. Contract or Grant # F29601-93-C-0086			
		5b. Program Element # 62601F			
6. Author(s) Jeffrey C. Holliday		5c. Project # 9991			
		5d. Task # SB			
		5e. Work Unit # 1R			
7. Performing Organization Name & Address Hollidaylabs Guysville, OH 45735		8. Performing Organization Report #			
9. Sponsoring/Monitoring Agency Name & Address Phillips Laboratory 3550 Aberdeen Ave SE Kirtland AFB, NM 87117-5776		10. Monitor Acronym			
		11. Monitor Report # PL-TR-94-1036			
12. Distribution/Availability Statement Distribution authorized to DoD components only; Proprietary Information; February 1994. Other requests shall be referred to AFMC/STI.					
13. Supplementary Notes					
14. Abstract The results of the Phase I SBIR effort are described. The program goal is to demonstrate improved flight-class cryocooler system performance through the application of innovative "Vulcan" linear motor technology developed by Hollidaylabs. An existing cryocooler hardware system, the Ball Flight Prototype BFP provided by Ball Aerospace, will be used for demonstration with several watts from around 65 K. Expected benefits of the Vulcan motor include: greater cryocooler heat-lifting capacity per unit input power; improved reliability/life-time through the elimination of flexing power leads, pressure vessel feedthroughs, and some contamination mechanisms; reduced Electro-Magnetic Interaction; and reduced system mass.					
15. Subject Terms cryocooler linear motor compressor Stirling					
Security Classification of			19. Limitation of Abstract Limited	20. # of Pages 40	21. Responsible Person (Name and Telephone #) Capt Jeffrey Wiese (505) 846-2686
16. Report Unclassified	17. Abstract Unclassified	18. This Page Unclassified			

GOVERNMENT PURPOSE LICENSE RIGHTS
(SBIR PROGRAM)

Contract Number: F29601-93-C-0086
Contractor: Hollidaylabs
Guysville, OH 45735

For a period of four (4) years after delivery and acceptance of the last deliverable item under the above contract, this technical data shall be subject to the restrictions contained in the definition of "Limited Rights" in DFARS clause at 252.227-7013. After the four-year period, the data shall be subject to the restrictions contained in the definition of "Government Purpose License Rights" in DFARS clause at 252.227-7013. The Government assumes no liability for unauthorized use or disclosure by others. This legend shall be included on any reproduction thereof and shall be honored only as long as the data continues to meet the definition on Government purpose license rights.

CONTENTS

<u>Section</u>		<u>Page</u>
1.0	SUMMARY	1
2.0	PROJECT BACKGROUND, APPROACH, EXISTING SYSTEMS	4
	2.1 BACKGROUND AND PROGRAM APPROACH	4
	2.2 TARGETED CRYOCOOLER APPLICATION AREA	7
	2.3 SELECTED EXISTING HARDWARE SYSTEMS FOR MOTOR REPLACEMENT	8
	2.4 REPLACEMENT MOTOR NOMINAL SPECIFICATIONS	11
3.0	NEW VULCAN MOTOR HARDWARE DESIGNS	14
	3.1 COMMON CHARACTERISTICS OF THE FVU AND AFU	14
	3.2 THE FUNDAMENTAL VULCAN UNIT	15
	3.3 THE ADVANCED FEATURES UNIT	16
4.0	INTEGRATION OF VULCAN MOTORS INTO THE BFP CRYOCOOLER SYSTEM	25
	LIST OF ABBREVIATIONS AND ACRONYMS	31

Accession For	
NTIS CRA&I	<input type="checkbox"/>
DTIC TAB	<input checked="" type="checkbox"/>
Unannounced Justification	<input type="checkbox"/>
By _____	
Distribution /	
Availability Codes	
Dist	Avail and/or Special
E-4	

FIGURES

<u>Figure</u>		<u>Page</u>
1	Existing BFP Configuration	10
2	Preliminary FVU Design Features	17
3	Alternate FVU Design Features	18
4	Preliminary AFU Design Features	21
5	Alternate AFU Design Features	22
6	Trends of Efficiency verses IPV Thickness	24
7	Integration of FVU into BFP	26
8	Integration of AFU into BFP	27

1.0 SUMMARY

The results of the Phase I SBIR effort are described here. The program goal is the demonstration of improved flight-class cryocooler system performance through the application of innovative "Vulcan" linear motor technology developed by HOLLIDAYLABS. Expected benefits to the cryocooler system application include greater cryocooler heat-lifting capacity per unit input power, as well as improved reliability/life-time through the elimination of flexing power leads, pressure vessel feedthroughs, and some contamination mechanisms. Reduced Electro-Magnetic Interaction (EMI) or reduced system mass are also anticipated benefits to cryocooler applications of the Vulcan linear motor technology.

The Phase I effort has resulted in

- 1) Selection of cryocooler application class and nominal operating point for the demonstration/evaluation.

- 1 to 2 W lift capacity from 65 K,
- single stage Stirling Cycle,
- single driven compressor, no counterbalance.

- 2) Selection of specific Cryocooler hardware system for the demonstration.

- Ball Aerospace Ball Flight Prototype unit provided by Ball Electro-Optics/Cryogenics Division (ECD).

- Back-up alternate selection is Hughes Aircraft SSC.

- 3) Development of system layout configurations for fitting the BFP system with two distinct Vulcan motor units. These motor units emphasize different features and entail various levels of risk. Support structures required to replace existing BFP motor with the two Vulcan units have been identified and roughly designed.
- 4) Completion of the Preliminary Design and an Alternate Design for the Fundamental Vulcan Unit (FVU). The FVU provides a low-risk, early demonstration of basic Vulcan features in the BFP.
- 5) Completion of the Preliminary Design and an Alternate Design for the Advanced Features Unit (AFU). The AFU provides demonstration of advanced construction and design methods and includes the Included Pressure Vessel (IPV) feature.

The anticipated Phase II effort will include

- 1) Design refinements and detailing for both the AFU and FVU, and associated support structures for fitting into the BFP cryocooler hardware.
- 2) Magnetic component development efforts in support of above design detailing. This will involve some test specimen component hardware.
- 3) Fabrication and construction of the FVU and AFU prototypes, and associated support structures.
- 4) Motor subsystem testing at HOLLIDAYLABS using dynamometer and other specialized motor testing

equipment. Testing and comparison of the FVU, AFU, and the previously existing BFP motor will be conducted as isolated subsystems, independent of the full cryocooler system.

- 5) Full cryocooler system testing and demonstration with each of the FVU, AFU, and previously existing BFP motors. This will provide basis for comparison and evaluation of the various features in relation to overall cryocooler performance. These tests to be conducted at Ball ECD in their BFP cryocooler hardware and will focus on performance working at 65 K.

2.0 PROJECT BACKGROUND, APPROACH, EXISTING SYSTEMS

2.1 BACKGROUND AND PROGRAM APPROACH

Many present and future Department of Defense missions utilize, or are enabled by the use of, small flight-class cryocoolers. Missions for these types of cryocoolers include cooling of infrared sensors and other critical electronic components in space and airborne systems. Small flight-class cryocoolers typically lift on the order of several watts of heat from source temperatures below 100 K. Linear electric motors are used to drive and/or control cryocoolers such as those that operate via Stirling and Joule-Thompson thermodynamic cycles. The linear electric motor technologies currently employed in these cryocooler systems leave considerable room for improvements in system performance and in reliability or life-time.

The focus of this SBIR program is on improving small flight-class cryocooler systems of DoD interest through the application of an innovative linear electric motor technology designated "Vulcan". The primary objective of the program is to demonstrate the operation and benefit of Vulcan linear motor hardware, within a specific, representative, existing flight-class cryocooler. This demonstration should provide direct measurement of the impact on system heat-lifting performance and provide empirical information relating to cryocooler/motor system interaction concerns.

The "Vulcan" linear motor technology developed by HOLLIDAYLABS offers significant advantages over other art in many key areas, among these are

- 1) Elimination or reduction of EMI and leaked magnetic fields.

- 2) Potential for high energy conversion efficiencies.
- 3) Potential for compact size and greater motor output power per unit mass.
- 4) Exclusion of heat-generating and contaminant-bearing components from the working fluid.
- 5) Elimination of flexing electric power leads and pressure vessel feedthroughs.
- 6) Magnetically robust design, resistance to overcurrent faults, and thermal demagnetization effects.
- 7) Capable of high ambient temperature operation.
- 8) Reduced rotational inertia of the moving components, which affects bearing life and vibration issues.

In contrast to the widely used moving-coil type motors, the Vulcan linear motor has no moving power conductors. The Vulcan electric power conducting components are static and can be located outside of the working fluid of the cryocooler, separated from the cryocooler gas by a pressure vessel. Also, the permanent magnets of the Vulcan motor are likewise static and can also be located outside of the cryocooler working gas.

The technical conceptual basis for the Vulcan has been successfully proven in previous hardware applications which utilize Vulcan devices as linear motors and as linear alternators. Successful coupling both to Stirling Cycle coolers and to heat engines has been demonstrated. Conversion efficiencies over 90% have been measured in Vulcan units of the approximate size and speed relevant to the flight-class

cryocooler application. Individual prototype Vulcan units have completed life testing accumulating over 10,000 hours of operation without measurable degradation or failure. This previous Vulcan hardware experience provides a good ground work for fundamental demonstration in the cryocooler field and a basis for further improvements, innovation, and development of more advanced features within the Vulcan class of linear motor.

The flight-class cryocooler applications targeted by this program do have some similarities with previous hardware applications of Vulcan technology. However, these cryocooler missions and systems have unique emphasis and requirements which need to be specifically addressed in evaluating the worth of Vulcan devices for these applications. Also, some of the very desirable features possible within Vulcan devices have not been fully proven or tested in previous hardware. The HOLLIDAYLABS Vulcan technology may be adapted or designed to specific performance goals by the incorporation of a variety of design and construction features.

In order to provide a cost-effective and meaningful demonstration of a variety of Vulcan capabilities, two separate Vulcan demonstration units are being developed for testing in the cryocooler hardware system. Each of these units and associated support structures are designed to replace the electric linear motor presently used in the selected cryocooler. The two Vulcan demonstration units have different performance/feature emphasis and associated levels of technical risk and pay-off. Both of these new motor units employ fundamental Vulcan concept basis. They differ in the number and complexity of design features involved and in the divergence from, or adherence to, previously practiced methodology in design and in construction. These two motor units have been designated as

- 1) The FVU - Fundamental Vulcan Unit -
- 2) The AFU - Advanced Features Unit -

Additional description of the FVU and AFU is found in later sections of this report.

In line with the program focus on motor subsystem technology, a previously developed cryocooler system is employed. Changes to the existing cryocooler system associated with the swapping of the existing linear motor for the Vulcan motor units are minimized where possible.

The in-system testing of the Vulcan units will provide relevant information, but the range of motor operating conditions that can be exercised is limited by the cryocooler system tolerances and design. A more complete exploration of the motor performance over a broader range of operating conditions will be accomplished by conducting isolated motor subsystem testing at HOLLIDAYLABS. This will provide information that will be especially useful for future efforts to integrate Vulcan motor technology with flight-class cryocoolers during the earlier system design stages, rather than as a retrofit.

2.2 TARGETED CRYOCOOLER APPLICATION AREA

The cryocooler application area targeted in this study for the demonstration of the Vulcan linear motor is

- order of 1 to 2 W lifted
- 65 K lift temperature
- single-stage Stirling Cycle type
- single compressor, single displacer

- flexural bearing system
- no counterbalance system

The selected Target Cryocooler Application Area is representative of a wide range of technology areas of DoD interest. The selection of a relatively simple configuration for the cryocooler system is desired in this study in order provide a clear view of the motor subsystem impact and to avoid additional cost and technical risk inherent in more complex application systems.

2.3 SELECTED EXISTING HARDWARE SYSTEMS FOR MOTOR REPLACEMENT

Both a Primary and an Alternate Existing Hardware System have been selected for use in this program. Much greater emphasis and level of effort has been placed on the Primary System. These existing cryocooler hardware systems serve as practical guideposts. They will eventually serve as a system benefit test-bed for the Vulcan motor technology. The later phases of this SBIR program will include testing and comparison of the Existing Hardware Systems operated with the original linear motor versus replacement with the Vulcan linear motor units, FVU and AFU.

The unit selected for the Primary Existing Hardware System is the BFP, which presently uses a low frequency, low aspect (L/D) ratio moving coil motor. The Hughes 65K SSC unit is selected as the Alternate Existing Hardware System. It also uses a moving coil motor but with greater frequency and aspect ratio than the Primary System. Both of these hardware systems are considered to be representative of the Targeted Cryocooler Application Area.

Ball ECD has developed the BFP system under internal research and development. Ball has agreed to allow HOLLIDAYLABS to use the system for the study and is providing relevant test and system information. Ball ECD will provide the BFP cryocooler system and facility/personnel for the in-system testing. The DoD sponsor has access to the Alternate Existing Hardware System.

Ball uses components of the BFP system in a variety of cryocooler configurations in order to meet a broad range of mission requirements. These configurations include systems with multiple compressors and additional vibration absorbers for compressors and displacers. The application target for the present study is relatively simple and comprises one compressor, one displacer, and no counterbalance. This is the configuration that is referred to as the BFP or Primary Existing Hardware System.

Figure 1 is a schematic representation of the compressor drive section of the presently existing BFP cryocooler. This figure is drawn somewhat smaller than 1:1 scale. Distances between parts not rigidly connected have been exaggerated, as have some shapes. The components identified in Figure 1 include those that will require some modification to accomplish the Vulcan motor substitution.

Several important aspects of the existing BFP system are evident in Figure 1. The existing motor is seen to have a key function in the mechanical support of the spring stacks. Both the front and rear spring stacks are mechanically grounded (to the stationary base) through the motor stator structure. The existing motor stator is made of a solid block of metal, providing the rigidity needed for this purpose. An earlier variation of the existing BFP had the front spring stack grounded directly to the base.

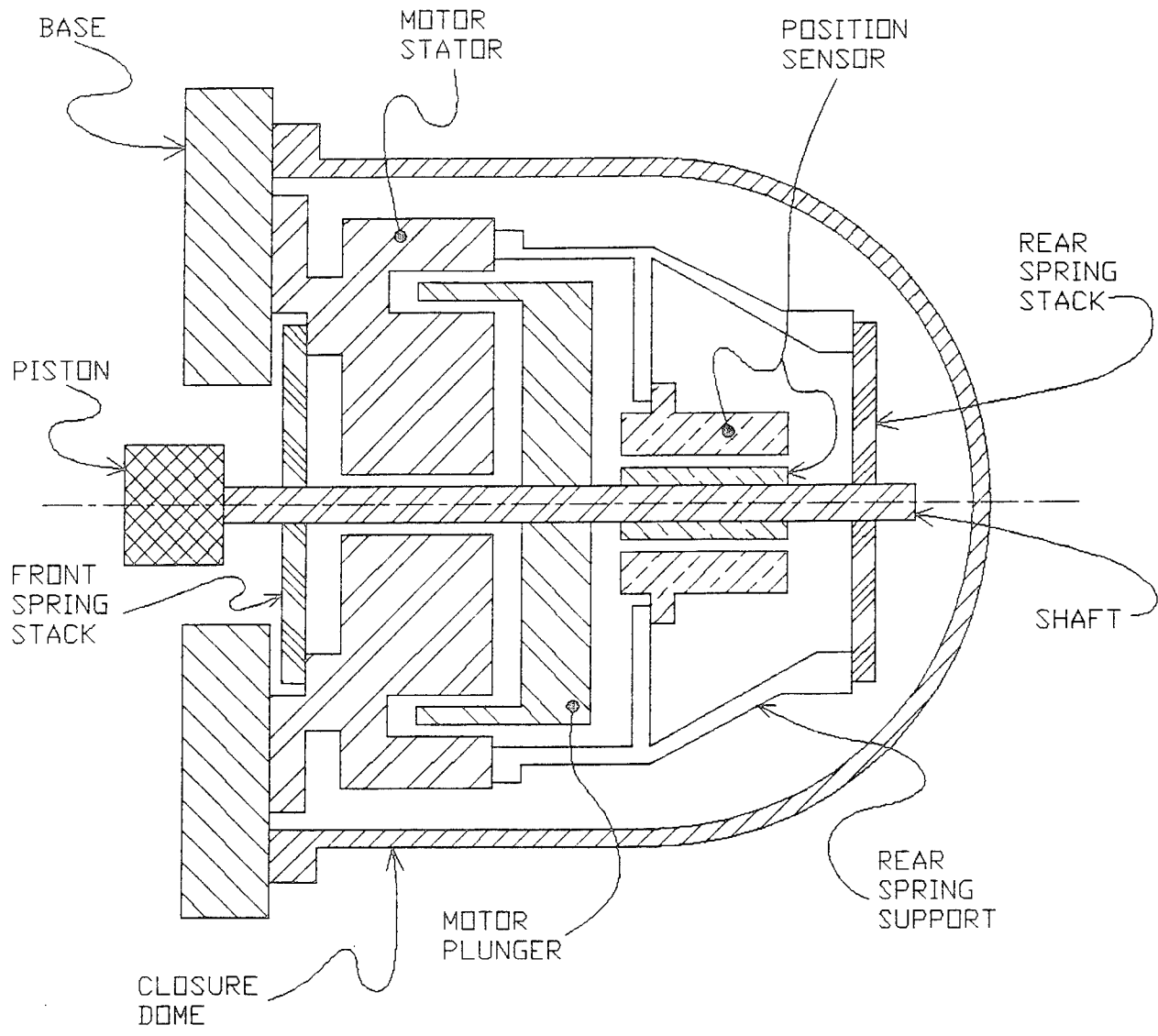

Figure 1. Existing BFP Configuration

The position sensor is a key component and has a critical role in the vibration mitigation system. It has both a stationary and reciprocating part. Its location is in part dictated by an inherent sensitivity of the position sensor to metal structures in its immediate environment. This limits the system configuration options viable for the Vulcan substitution.

The current position sensor operates via a capacitive principle and has a very good track record with regard to reliability. Substitution of this sensor with another sensor type less sensitive to environmental structure (such as commercial position sensors presently used at HOLLIDAYLABS with Vulcan hardware and new sensor technology under development at HOLLIDAYLABS) would be a good follow-on effort, but is not expected to be attempted in the current program. Such a follow-on effort could also continue to pursue a more integrated motor/sensor technology configuration that HOLLIDAYLABS has begun and which could eliminate sensor lead feedthroughs. In this current SBIR program, the working plan is to utilize, and avoid interaction with, the present position sensor.

2.4 REPLACEMENT MOTOR NOMINAL SPECIFICATIONS

The nominal operating specification (target) for the Vulcan motor units for demonstration in the BFP cryocooler system is 40 W mechanical output at 44.625 Hz. The nominal piston amplitude is 4.0 mm with maximum amplitude capability of 4.5 mm.

The nominal operating specification has been made in consideration of the thermodynamic and mechanical configuration that the BFP system hardware is expected to be set in at about the time the Phase II demonstration is to take place. The nominal frequency is expected to be an effective operating point

for the BFP cryocooler working against a 65 K lift temperature. Operation at other frequencies will also be possible.

The 40 W power specification provides a modest overcapacity relative to the expected actual compressor requirement of 36 to 38 Wm. Operation of the AFU or FVU at output power less than nominal will result in greater motor energy conversion efficiency. Both units will be capable of delivering much greater power than the nominal specification.

Available performance test data for the BFP system brackets the 65 K point. The BFP can lift 1.3 W at 80 K with 36 W input. The BFP can also be operated at 60 K to lift 0.75 W with a 47 W input. This input power includes the electronics. The BFP existing motor is believed to deliver approximately 32 to 34 W at <82% efficiency during system performance of 0.75 W lift at 60 K.

Also of practical interest in terms of potential system benefit is the operation of the linear motor during "flat-out" system operation. This is the highest heat lift capacity condition for a particular lift temperature. System efficiency and motor efficiency are reduced at the higher capacity points. The BFP hardware has been operated at several such high lift capacity conditions. Typically, the present BFP motor is thought to be operating with about 45 W output at roughly 75% efficiency, during flat-out system testing.

The integration of the linear motor and the spring stack system is one of the most important aspects of the current application problem and leads to a mass restriction specification for the Vulcan designs. The piston of the target cryocooler application is supported by a pair of "spring stacks", also referred to as "flexural bearings". These spring stacks provide

the radial (bearing) force required to maintain a very close, noncontacting, clearance of the piston and its cylinder. This piston/cylinder clearance is very small (order of 20 μm) and thereby acts as a seal between the working space and the ballast region of the cooler. The bearings also provide most of the axial (spring) force needed for piston mechanical resonance near the system frequency. This limits the allowable mass of the reciprocating components of the system. Specifically, this links the allowable mass of the motor plunger to the detail of the spring stack system.

The plunger mass of the current BFP hardware is about 210 g. It is believed that the BFP system can easily tolerate a plunger mass of up to 350 g, which is the value used for an upper-bound for the Vulcan motor unit specification.

The BFP system testing currently underway at Ball ECD involves the use of a different compressor spring stack configuration, which is expected to be adopted for the Phase II demonstration. This new spring configuration results in a stronger axial spring force than the preceding configuration. This may allow a greater reciprocating mass allowance for the motor units to counteract the higher natural mechanical frequency that the stronger springs cause. The motor unit designs can take advantage of the increased reciprocating mass allowance by increasing motor efficiency, without requiring an increase in total mass.

The tests of this new BFP hardware configuration at Ball ECD are expected to provide definitive information regarding the value of reciprocating mass that can be allowed for the final Phase II motor unit designs. Because these test results are not available at the time of this report, the previous reciprocating mass limit of 350 grams was preserved for the Preliminary and

Alternate Designs of the FVU and AFU. It is anticipated that the testing at Ball will be completed by or within the first few months of the Phase II effort.

3.0 NEW VULCAN MOTOR HARDWARE DESIGNS

3.1 COMMON CHARACTERISTICS OF THE FVU AND AFU

Four different Vulcan motor designs are currently considered for potential application as the FVU and AFU. Two designs have been developed for each of the FVU and AFU. These are referred to as Preliminary and Alternate Designs. The Preliminary Designs utilize relatively lower-risk construction and design methods. The Alternate Designs use more advanced construction and design details which have potential benefits such as increased conversion efficiency and reduced reciprocating mass. A down-selection between the Preliminary and Alternate Designs for each of the Vulcan demonstration units will be made in Phase II, and final designs for the FVU and AFU will be based accordingly.

The four current Vulcan motor designs developed for this project have some common characteristics. In general, the Vulcan linear motor consists of two gross components: a stator and a plunger. The plunger is the part of the motor that undergoes reciprocating motion and includes only yoke (iron) and support components. In the present application, the plunger is integral with the compressor piston of the stirling cryocooler.

The stator is the normally stationary part of the linear motor. In Vulcan class devices the stator includes the permanent magnets, conductors, and most of the yoke components. In this application the Stator is ultimately fixed to the BFP base.

All the Vulcan designs in this program have cylindrical symmetry about the central axis. The plunger is located radially inside of the stator and is made hollow to allow the device centerline to be occupied by the compressor piston shaft. This arrangement is chosen in order to facilitate mechanical integration with the spring-stack/bearing system.

Magnetic materials called for by these designs include laminated 48Co-2V-Fe and sintered Nd-Fe-B. The reciprocating mass of the Vulcan units are presently estimated between 188 to 348 g. The plunger mass of the current BFP hardware is about 210 g. It is believed that the BFP system can tolerate a plunger mass of up to 350 g, which is the value used for an upper-bound for these designs.

3.2 THE FVU, FUNDAMENTAL VULCAN UNIT

The FVU is intended to provide an early and relatively low technical risk demonstration of basic Vulcan advantages including low EMI, high efficiency, and static power leads. The FVU is designed to employ construction and design methods that have largely been successfully applied to other Vulcan hardware systems. A system configuration for fitting the FVU to the BFP cryocooler has been developed, and both a Preliminary FVU motor unit design and an Alternate FVU design have been completed in Phase I. The Preliminary FVU Design is more conservative than the Alternate and holds strictly to previously exercised methodology (i.e., direct hardware experience). The Alternate FVU Design employs a moderate amount of some advanced construction and design improvements which offer reduced reciprocating mass and improved conversion efficiency. A brief effort to verify analysis and construction methods used in the

Alternate FVU Design will be carried out early in Phase II. Results will be used to refine the final FVU design based either on the Preliminary or on the Alternate Design.

Physical features of the Preliminary FVU Design are shown in Figure 2. Power conversion efficiency at rated 40 W output is expected to be about 86%. At somewhat lower power output levels, conversions efficiencies approaching 90% are expected.

In this application, the motor conversion efficiency of this type of Vulcan motor is limited by the allowed reciprocating mass. The allowed reciprocating mass is driven by the system dynamics and the design of the mechanical spring system. An increase of rated efficiency to 88% could be achieved in this type of device if an increase of 90 g were allowed in reciprocating mass. Total motor mass would be essentially unchanged.

Physical features of the Alternate Design for the FVU are shown in Figure 3. The Alternate FVU Design offers reduction of the reciprocating component of motor mass. The Alternate FVU Design shown is rated at 40 W output at 86% efficiency. A design along the lines of the Alternate FVU could also allow greater motor conversion efficiency for a given reciprocating mass allowance.

3.3 THE ADVANCED FEATURES UNIT

The AFU will demonstrate the IPV feature. In this arrangement, the motor stator is separated from the working gas by the pressure vessel, which is located between the motor stator and motor plunger, thus the descriptive name "included". The feature offers some significant advantages to the cryocooler

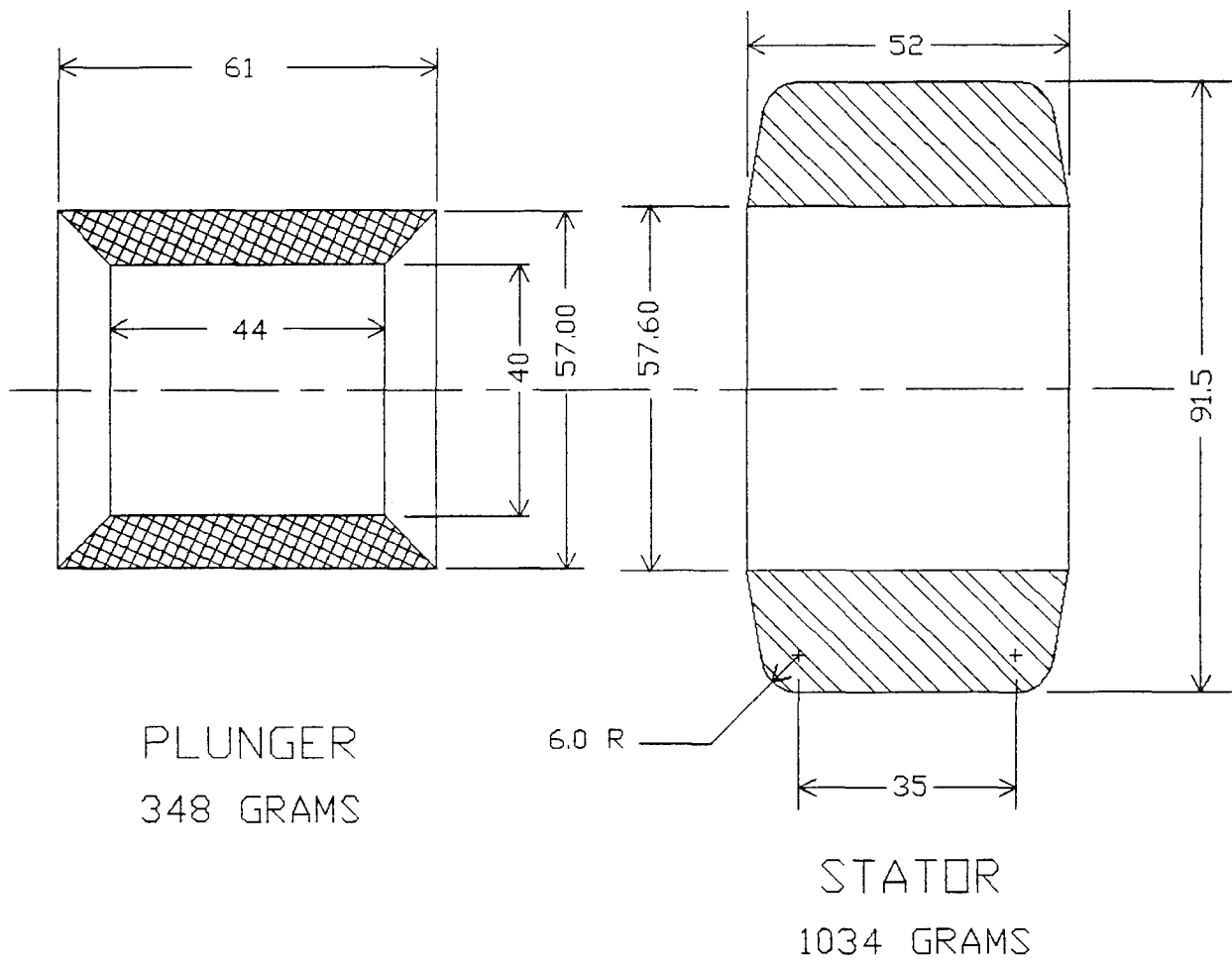

- Static Power Leads
- Low-Risk Construction

Figure 2. Preliminary FVU Design Features

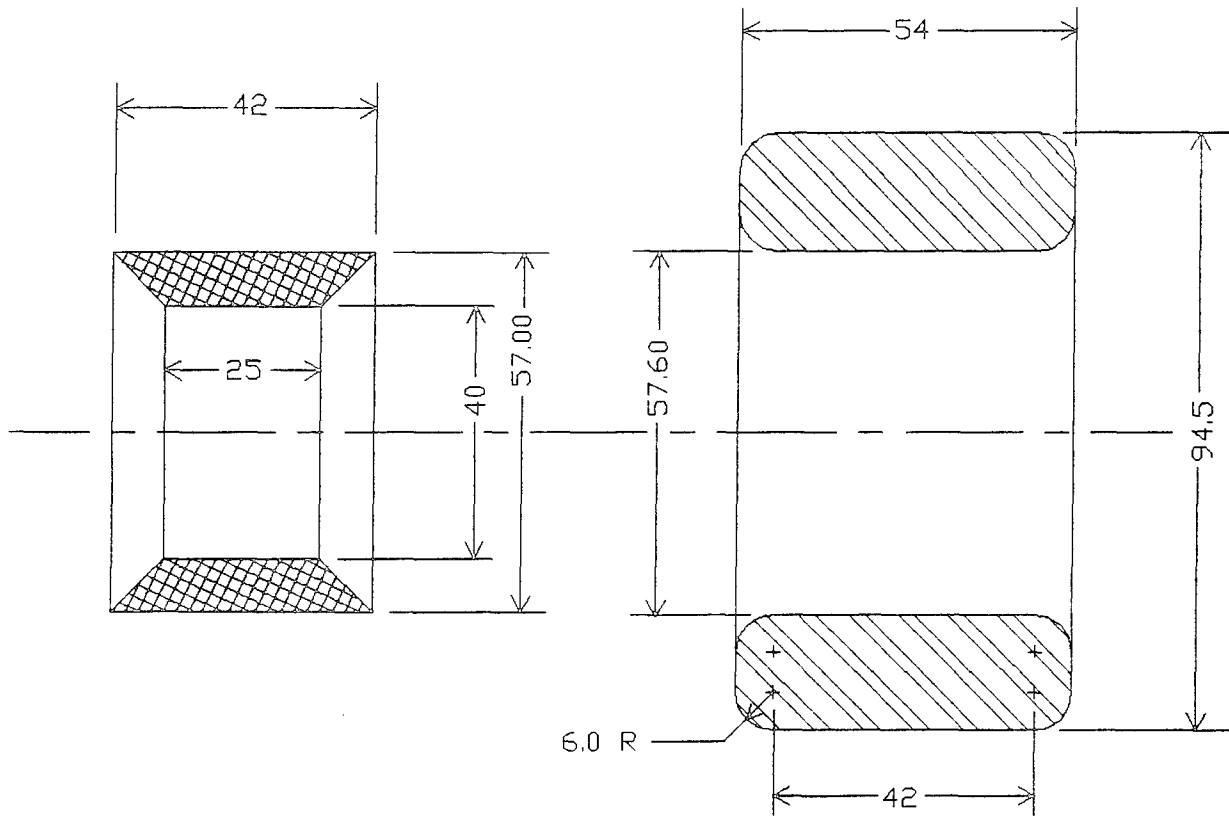

PLUNGER

266 GRAMS

STATOR

1169 GRAMS

- Static Power Leads
- Advanced Construction

Figure 3. Alternate FVU Design Features

system. Among these are that the IPV:

- 1) Allows the elimination of electric power pressure vessel feedthroughs for the motor;
- 2) Eliminates most working gas contamination from motor sources;
- 3) Removes most heat generating components of the motor from the working gas.
- 4) Has the potential for the elimination of the position sensor output lead feedthroughs.

In the current program plan, the existing BFP position sensor is to be used, which requires lead feedthroughs. The sensor lead feedthroughs could be eliminated if the present sensor were to be replaced by position sensing technologies currently under development at HOLLIDAYLABS. Two approaches are now being developed: (1) one which integrates position sensing function with the motor power structure and (2) another independent, or dedicated device which has a character analogous to the IPV in that the sensor leads can be located outside the pressure vessel, and need not involve feedthroughs. Either of these sensing systems could conceivably be retrofitted to the FVU or AFU systems built for this program. This may be a good follow-on to the current effort but is not within the present scope of the program.

Incorporation of the IPV into the cryocooler system and motor design is not without consequence or challenge. Among the disadvantageous trends of the IPV are:

- 1) Potential difficulty in mechanical design with regard to fabrication and to natural structural resonances;
- 2) Introduction of additional power loss mechanisms within the motor, primarily manifested in heat generated within the IPV itself;
- 3) Effects that tend to increase motor radiated EMI and decrease motor specific power ("motor specific power" is the ratio of the rated power output to the total motor mass, Watts per kilogram). This is not to be confused with the thermodynamic system specific power which involves heat lift and power input.
- 4) May necessitate permanent physical integration (attachment) of the IPV structure with the motor stator during initial fabrication, which could effect maintenance considerations. This may allow mechanical structural support of the IPV by the motor stator, which may prove desirable.

The Preliminary Design for the AFU is shown in Figure 4. The Alternate Design is shown in Figure 5. The Preliminary AFU Design is of relatively low technical risk but is not as well adapted to the IPV feature consequences as the Alternate AFU Design is. The Alternate AFU Design involves a number of design and construction features that have not been fully developed (reduced to practice) and, therefore, is of fairly high technical risk. It is anticipated that the issues involved with the Alternate Design will present some development challenge, but all are expected to be ultimately successfully engaged.

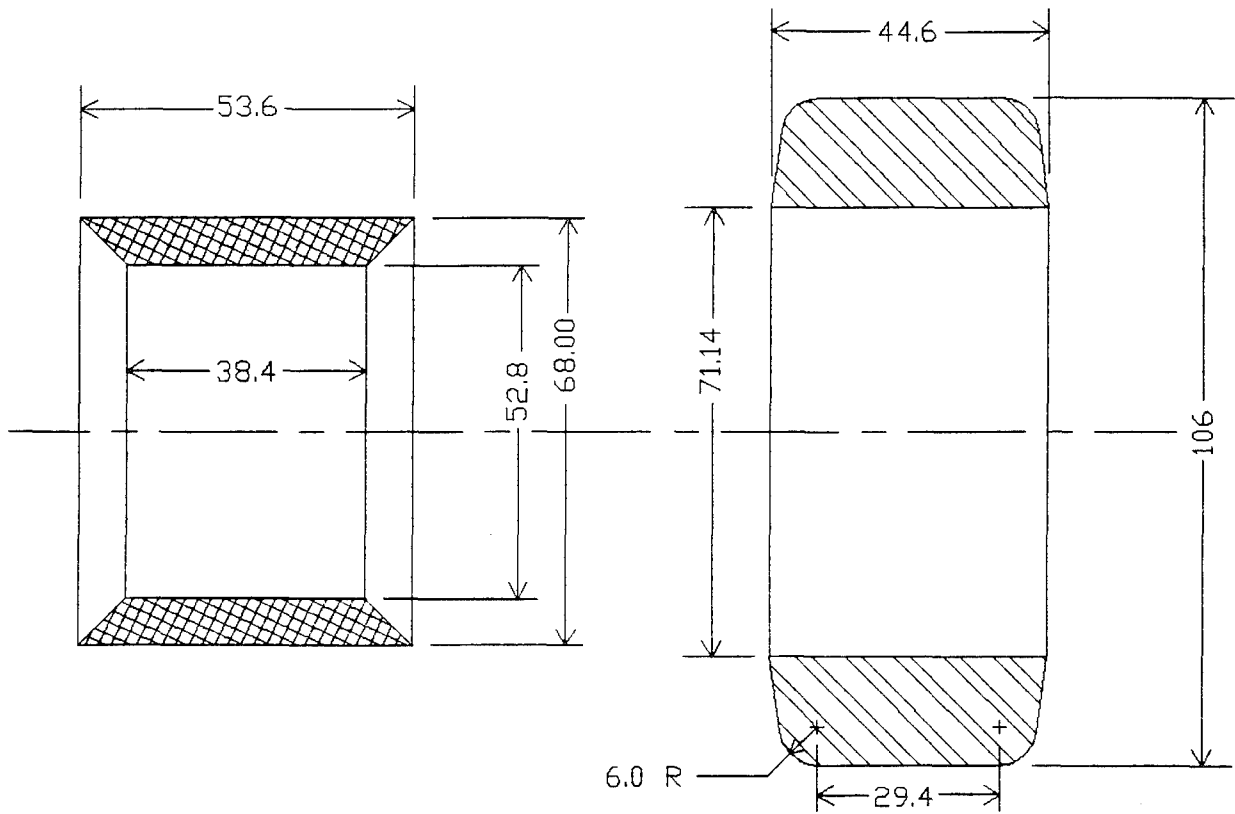

PLUNGER

347 GRAMS

STATOR

1139 GRAMS

- IPV Feature
- External Static Power Leads
- Low-Risk Construction

Figure 4. Preliminary AFU Design Features

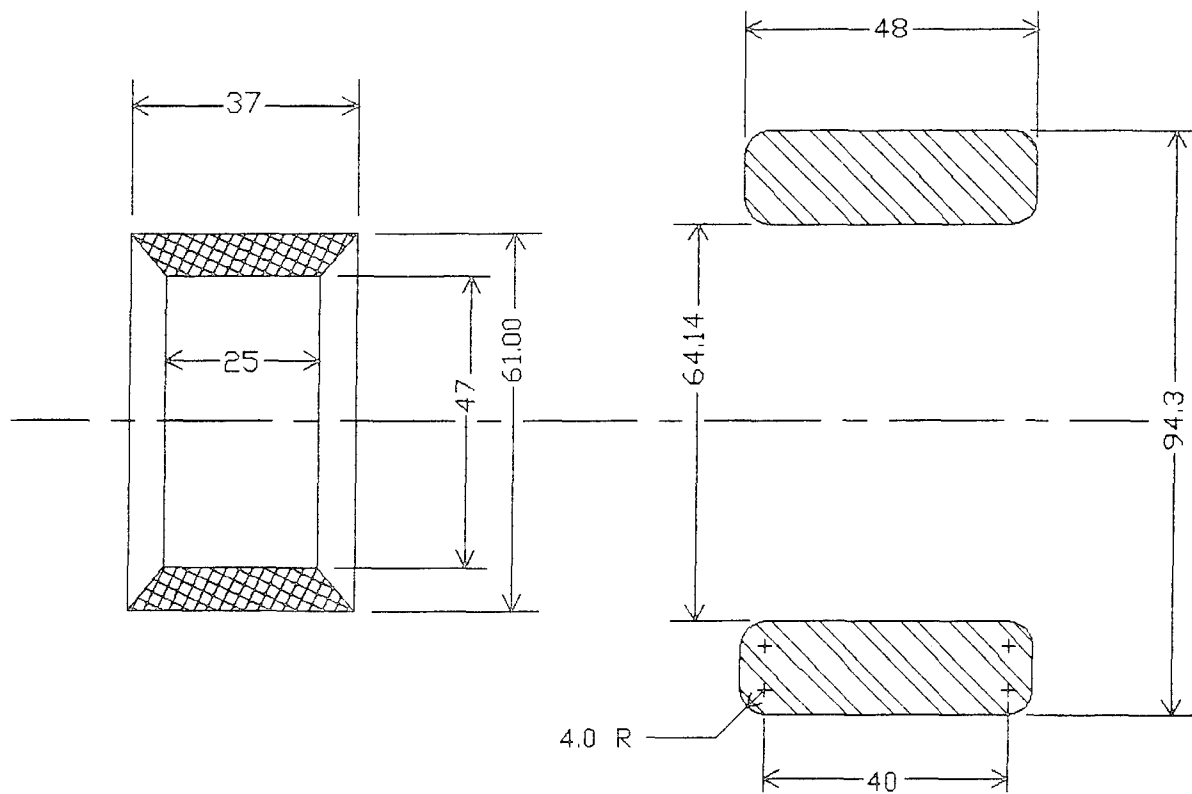

PLUNGER

188 GRAMS

STATOR

1278 GRAMS

- IPV Feature
- External Static Power Leads
- Advanced Construction

Figure 5. Alternate AFU Design Features

Both of these designs involve the IPV composed of 0.050" thick 6Al-4V-Ti. This thickness was chosen for a robust, stiff, easily fabricated component and is probably much thicker than otherwise actually needed. The IPV is lightly loaded by working gas pressure and spring stack grounding support in the BFP. This light loading could be borne by an IPV thickness of less than 0.010" if fabrication and natural resonance issues were accounted for.

Figure 6 shows the trends in motor conversion efficiency as a function of the IPV thickness. The two curves are for the motor design types represented by the Preliminary AFU and the Alternate AFU. It is clear from this graph that further effort in Phase II to develop a satisfactory mechanical IPV design with a reduced wall thickness can have significant payoff in terms of motor conversion efficiency. The electrical conductivity of the IPV material is also a factor in motor efficiency. The titanium alloy currently used has a relatively low electrical conductivity as metals go. Use of a nonconducting or lower electrical conductivity material will also be investigated in Phase II.

At the 0.05" IPV thickness, the Preliminary AFU Design conversion efficiency rating is 72% at 40 W output, the Alternate AFU Design rating is 80% at 40 W output. Design refinement and improvements for the AFU during Phase II are expected to improve rated efficiency for the final AFU design. If Alternate Design is further developed, conversion efficiency of 88% should be achievable. Conversion efficiency around 83% should be attainable upon further development along the line of the less risky Preliminary AFU Design path.

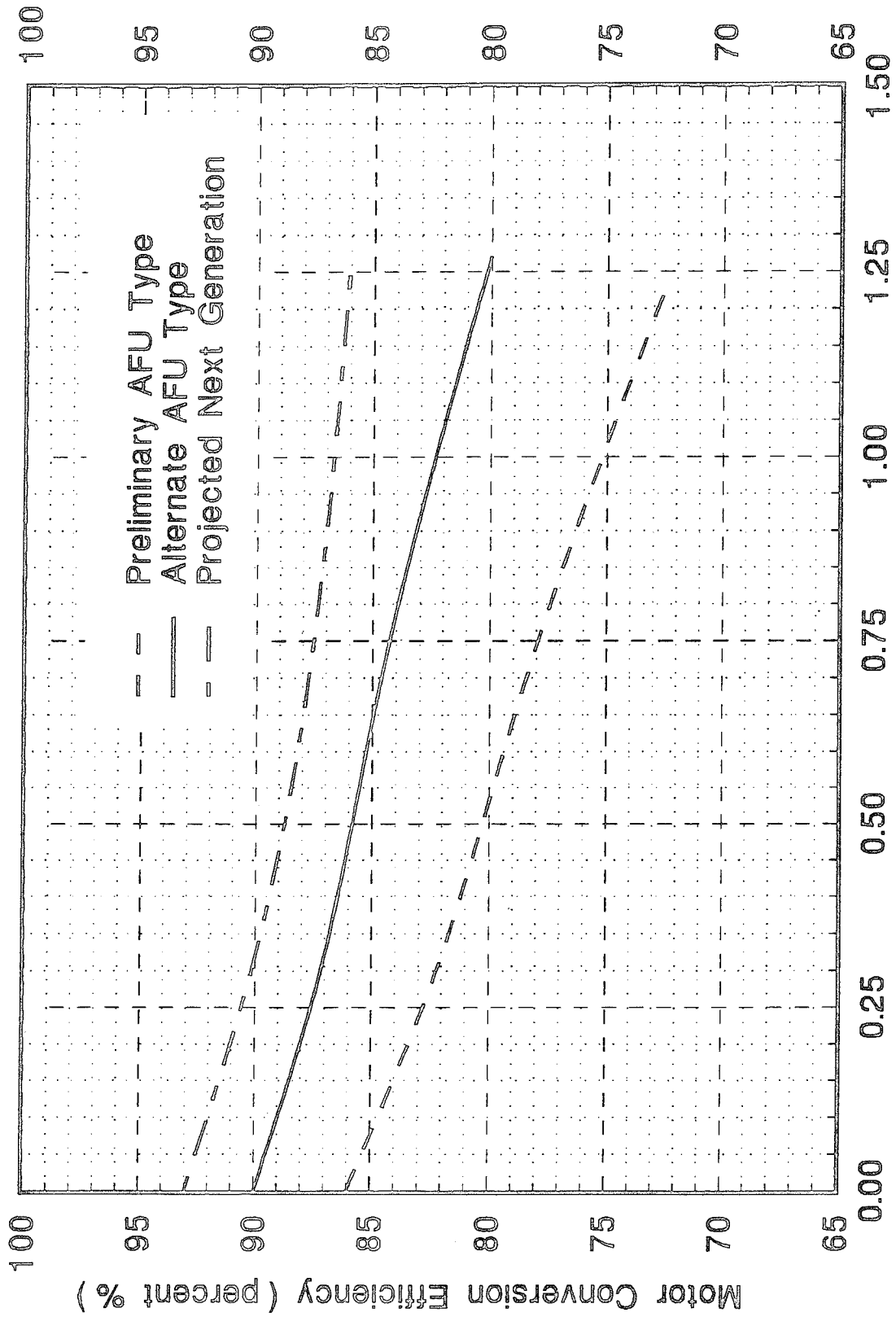

Thickness of IPV (mm of Ti6Al4V)

Figure 6. Trends of Efficiency Versus IPV Thickness

4.0 INTEGRATION OF VULCAN MOTORS INTO THE BFP CRYOCOOLER SYSTEM

Figures 7 and 8 illustrate how the FVU and AFU motors are integrated into the BFP cryocooler for in-system demonstration and testing. These are schematic representations and are at roughly 1:1 scale. Only the compressor drive section of the cryocooler is shown. Components that will be fabricated for this program are indicated by cross-hatching. Refer to Figure 1 for comparison to the pre-existing BFP system.

The in-system configurations for the FVU and AFU demonstrations have some important similarities. This should help to minimize the system shake-out efforts required when swapping the motor units.

Several of the components shown are unchanged from the pre-existing BFP configuration. The compressor piston and the base are not changed. These are the parts of the existing system to which the replacement components for the FVU and AFU demonstrations are ultimately attached. The position sensor is unchanged except for its location relative to the spring stacks.

In both of the Vulcan demonstration systems, a single dedicated spring support structure will provide the mechanical grounding function for both spring stacks in the BFP compressor. This approach will be employed in both the FVU and AFU demonstrations. Both spring stacks will be attached to the support structure at their outer diameters, and the support structure will be attached directly to the base.

The Vulcan motor stator units will be independently mounted onto this spring support structure, and will be located between the spring stacks. The Vulcan motor stator units themselves will

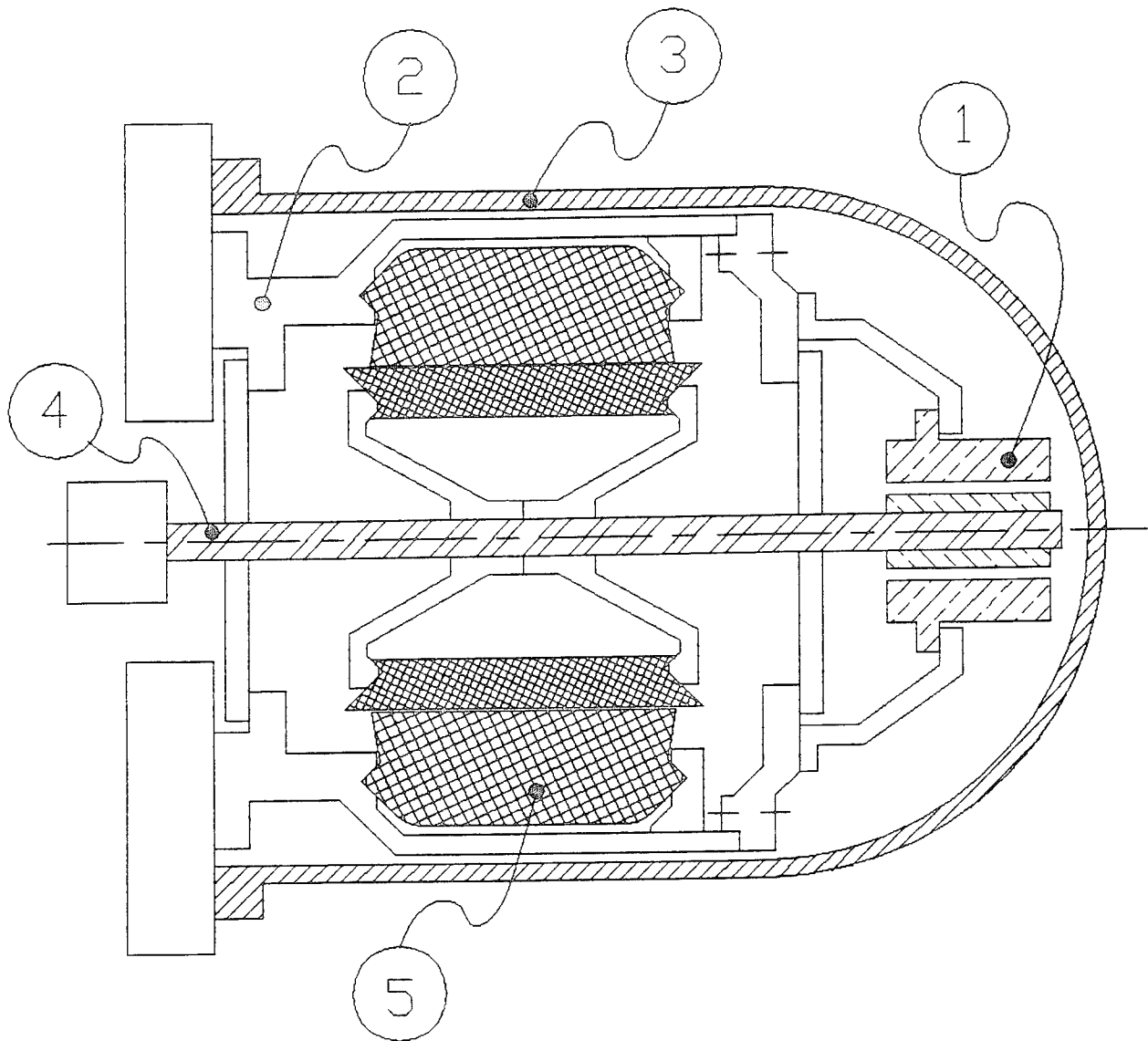

- ① Position Sensor Located Distal to Both Spring Stacks
- ② Spring Support Modified for Motor Mounting and Position Sensor Mounting Changes
- ③ Closure Dome Lengthened on Order of 25mm
- ④ Shaft Lengthened and Modified for Sensor Mount
- ⑤ Shown Fitted with Preliminary FVU Motor

Figure 7. Integration of FVU into BFP

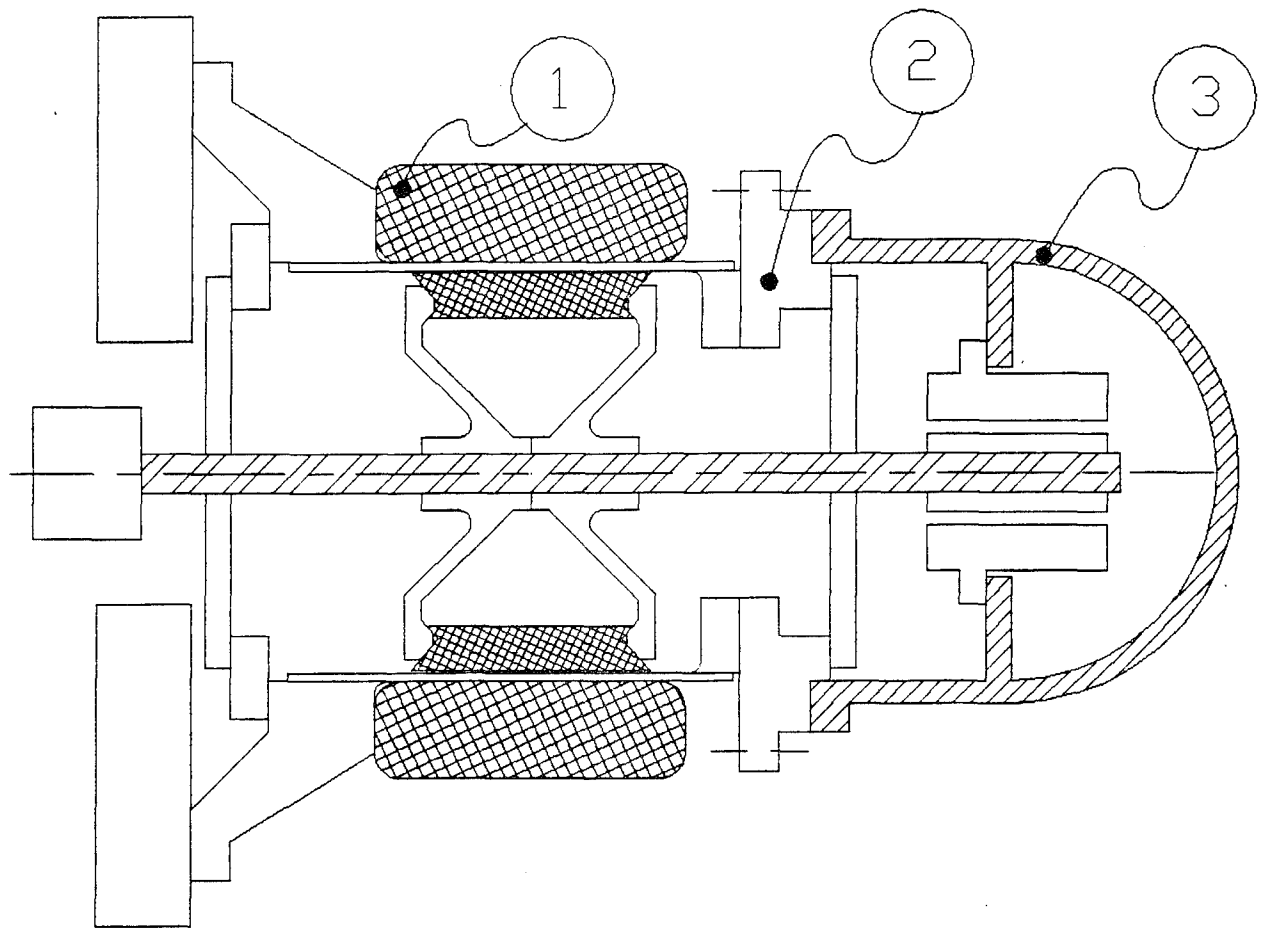

- ① Motor Modified for Included Pressure Vessel
Shown as Alternate AFU
- ② Single Structure Functions As
Pressure Vessel, Spring Stack Support, and Motor Mount
- ③ Closure Dome Reduced to Far-End Area
- Shown with Position Sensor Mount Function

Figure 8. Integration of AFU into BFP

not be directly involved in providing spring stack grounding function. The existing BFP motor stator does have a role in spring stack grounding. The selected approach ensures mechanical integrity for the spring/bearing system and releases construction constraints on the motor stator design.

Another feature common to both the FVU and AFU demonstration configurations is the location of the position sensor distal to the pair of spring stacks. This facilitates the mounting, alignment, and maintenance of the position sensor. The sensor can be accessed by simply removing the closure dome, and does not require disturbance of the spring stacks, motor mountings, or alignments. This feature is in contrast to the current BFP system, which involves the position sensor with the motor between the spring stacks. The distal sensor location eases design restrictions on the design of the Vulcan motor units and their mountings by allowing a larger dedicated area for occupancy by the motor and reducing concerns relating to sensor function in the proximity of the motor and moving conductive materials.

This distal mounting of the position sensor also has the practical benefits of: (1) facilitating replacement of the current sensor with another position sensor technology type, which may become an objective of a future project; and (2) being easily carried out in subsystem tests using the HOLLIDAYLABS dynamometer.

A shaft at the compressor centerline is used to tie the reciprocating components together in both the Vulcan demonstration and the preexisting configurations. The shafts for these configurations have design differences to account for the motor plunger and position sensor mounting differences. This mounting will involve the use of stand-off sleeves and a single compression nut. The spring stacks are attached to the shaft at

their inner diameters and have approximately the same axial separation in all configurations.

The use of only the shaft and spring support structure as alignment references allows easy assembly and relative alignment of the compressor piston, motor, spring stacks, and position sensor. Once these components have been assembled and aligned, this subassembly can be attached to the base, and the final critical alignment with respect to the piston cylinder (part of the base) can be made.

The axial separation distance between the spring stacks of the preexisting BFP system hardware is preserved in the Vulcan demonstration configurations. This is done primarily to minimize perturbation of the bearing/spring system. It also results in some excess space in the motor region and requires an overall lengthening of the shaft and closure dome by about an inch.

As shown in Figure 7, the configuration for the FVU demonstration uses a closure dome of similar concept and diameter as the pre-existing BFP. This closure dome attaches directly to the base as in the preexisting system.

In the configuration for the AFU demonstration (Fig. 8), the simple closure dome is replaced by a two part structure. This is comprised of a much reduced closure dome, which covers only the position sensor region, and of the IPV. The IPV structure must provide support for the spring stacks and motor stator and bear the pressure loads of the ballast area. The IPV tentative design calls for a 0.050" thick wall of 6Al-4V-Ti between the motor plunger and stator.

As shown in Figure 8, the IPV structure involves a flange at the closure dome end to provide a sealing and mounting surface.

This flange prevents the full motor stator from being slipped over the end of the IPV and closure dome. If the motor stator inner diameter were enlarged, an IPV arrangement could be designed to allow the motor stator to be slipped over the IPV end. This might facilitate assembly or maintenance/replacement of the motor stator. This issue will be further investigated in the next phase of the program.

LIST OF ABBREVIATIONS AND ACRONYMS

AFU = Advanced Features Unit

BFP = Ball Flight Prototype

ECD = Electro-optics Cryogenics Division (of Ball Aerospace)

EMI = Electro-Magnetic Interaction

FVU = Fundamental Vulcan Unit

IPV = Included Pressure Vessel

DISTRIBUTION LIST

AUL/LSE
Bldg 1405 - 600 Chennault Circle
Maxwell AFB, AL 36112-6424 1 cy

DTIC/OCC
Cameron Station
Alexandria, VA 22304-6145 2 cys

AFSAA/SAI
1580 Air Force Pentagon
Washington, DC 20330-1580 1 cy

PL/SUL
Kirtland AFB, NM 87117-5776 2 cys

PL/HO
Kirtland AFB, NM 87117-5776 1 cy

Official Record Copy
PL/VTPT
Kirtland AFB, NM 87117-5776 10 cys

PL/VT
Dr. R.V. Wick
Kirtland AFB, NM 87117-5776 1 cy

NASA/GSFC
Attn: Dr Stephen Castles
Mail Code 713.4
Greenbelt, MD 20771 1 cy

Jet Propulsion Laboratory
Attn: Dr Ron Ross
Mail Code 157-102
4800 Oak Grove Dr
Pasadena, CA 91109 1 cy

National Institute for Standards and Technology
Attn: Ray Radebaugh
MS 583.30
Boulder, CO 80303 1 cy

Naval Research Laboratory
Attn: Tom Kawecki
Code 8241
4555 Overlook Rd, SW
Washington, DC 20375-5000 1 cy

Naval Research Laboratory
Attn: Martin Nisenoff
Code 6850.1
4555 Overlook Rd, SW
Washington, DC 20375-5000 1 cy

BMDO/TNC
Attn: Dr Walt Dyer
1E168
The Pentagon
Washington, DC 20301-7100 1 cy

PL/VTP
Attn: Lt Col David H. Kristensen
Kirtland AFB, NM 87117-5776 1 cy

SMC/MGSS
Attn: Lt Eugene Croft
P.O. Box 92960
Los Angeles AFB, CA 90009-2960 1 cy

BMDO/TNS
Attn: Mr Erwin Myrick
1E130
The Pentagon
Washington, DC 20301-7100 1 cy

PL/XPI
Attn: Bob Hancock
Kirtland AFB, NM 87117-5776 1 cy