

UNCLASSIFIED

AD NUMBER
ADB189913
NEW LIMITATION CHANGE
TO Approved for public release, distribution unlimited
FROM Distribution authorized to U.S. Gov't. agencies and their contractors; Administrative/Operational Use; 20 JUL 1960. Other requests shall be referred to National Aeronautics and Space Administration, Lewis Research Center, Cleveland, OH.
AUTHORITY
NASA TR Server Website

THIS PAGE IS UNCLASSIFIED

AD-B189 913



COPY

ELECTRIC POWER GENERATION SYSTEMS FOR USE IN SPACE

By Henry O. Slove and Seymour Lieblein

Lewis Research Center  
Nation Aeronautics and Space Administration  
Cleveland, Ohio

INTRODUCTION

In 1957, with the launching of the first artificial earth satellite by the U.S.S.R., we entered the age of scientific exploration of space. From such exploration, we hope to vastly increase our scientific knowledge of the earth and the universe, provide better world communications, improve weather forecasting, and ultimately pave the way for interplanetary travel.

To date, there have been many successful scientific satellites and space probes launched by the U.S.A. and U.S.S.R. A detailed listing of the various launchings up to May 1960 and a brief description of the experiments associated with them are given in figure 1. Many important discoveries and advances have already resulted from these satellites and space probes [1, 2, 3]: for example, the discovery of the Van Allen radiation belts around the earth, new information about the earth's magnetic field, a revised shape of the earth, and pictures of the back side of the moon and the earth's cloud cover.

This, however, is only the beginning. The next decade will undoubtedly see an acceleration of the number of scientific and technological satellites and exploratory probes. In the U.S.A. the National Aeronautics and Space Administration, the NASA, plans to launch a total of 260 major scientific vehicles at the rate of about two per month for the next decade. Anticipated missions will vary from scientific earth satellites to deep space probes and manned flight around the moon, with a manned lunar landing to come in the 1970's. This 10-year program, of course, will be modified from year to year on the basis of realized experience, development progress, and resource availability.

"DTIC USERS ONLY"

DTIC QUALITY INSPECTED 5

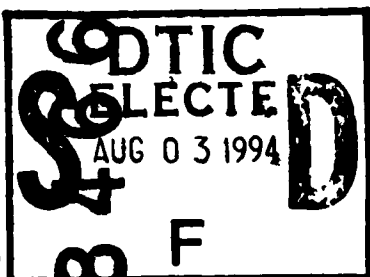

E-924  
CN-84665

94-23990



120

The rate of progress in space exploration will depend on the rate of development of our space technology. Space technology is a rather complex field covering the following major aspects: the development of powerful launch vehicles to carry large payloads; the perfection of accurate control and guidance mechanisms; the design of compact and light-weight instruments to record and transmit space data; the construction of reliable life support systems for manned space flight; and the development of efficient reliable long-life electric power generation systems.

This paper is concerned with the electrical power supply aspect of space technology. Its purpose is to present a survey of the space power production field by indicating current and future power requirements and reviewing major types of available and proposed power conversion systems. It will also discuss the areas of application for these systems along with some of the developmental problems involved.

#### POWER REQUIREMENTS

Electrical power in space is needed for auxiliary power and primary propulsion requirements. By auxiliary power is meant the electrical power needed for scientific and communications equipment, satellite attitude and position control equipment, life support systems, and planetary transportation and power stations. Primary propulsion refers to the electric power required for space vehicles using ion or plasma accelerators for propulsion [4, 5].

For many space missions, especially those involving man, it is desirable to have several electrical power systems: a system to supply the average power demand, a system to meet peak power demands or be available to meet average demands when the main power supply is not operating, and a standby power system for emergency purposes. Although the specific amounts of power required is a complex thing to determine, some rough generalizations about the power levels required in the near future can be made. First, it is clear that as allowable

12

payloads become heavier, more sophisticated and more numerous experiments will be launched, and thus more power will be required. In general, therefore, power level requirements can vary roughly with the payload capabilities of the available boost vehicles. An indication of the expected increase in scientific payload weight in the next decade as planned by the NASA is shown in figure 2. Payload capabilities for a near-earth orbit and a lunar probe mission are shown by the solid lines, and the various boost vehicles expected to give these payloads and their expected availability dates are shown at the bottom of the figure.

The second generalization that can be made is that the type of mission will roughly define the power level required. For example, for the next 5 to 8 years it is anticipated that, for unmanned scientific satellites and probes, power requirements of up to about 5 kilowatts will be adequate in most cases [6]. An average power of about 260 watts and a peak power not to exceed 1000 watts will be required for the first manned flight planned by the NASA. This mission, called Project Mercury, will send one man into a low-altitude orbit for about 4 hours [7]. Following Project Mercury, early manned flight may require up to about 2 kilowatts per man depending on the duration of the flight.

Primary electric propulsion systems for unmanned probes are expected to call for power levels from about 30 kilowatts up to about 2 megawatts for the next decade. These propulsion power requirements were estimated from considerations of the probable ratio of electric-vehicle powerplant weight to gross weight (e.g., [8]), and powerplant specific weight (this will be discussed later) assuming electric-vehicle gross weight is equal to launch-vehicle payload weight (fig. 2).

On the basis of these payload and mission considerations, it was possible to estimate the power requirements over the next decade as shown in figure 3. The lower curve shows the anticipated maximum average powers required for

nonpropulsive purposes, and the upper curve indicates the requirements for primary electric propulsion based on single boost-vehicle payload capacity. The conclusion to be drawn from figure 3 is that in the next decade, total amounts of power ranging anywhere from several hundred watts up to several megawatts will be required.

#### POWER GENERATION SYSTEMS

Now that an estimate of power requirements for the next decade has been presented, the question that arises is what power generation systems are available to best satisfy these power needs? In answering this question, let us first examine the power systems that are in use at present and see if they can meet the expected needs.

##### Current Systems

To date, all the scientific satellites and space probes have received their electrical power from either primary electrochemical batteries or from solar photovoltaic cells in conjunction with an electrochemical battery storage system (see fig. 1). The chemical batteries used have been conventional types like the mercury or zinc-silver cell. The solar cells at present are the well-known silicon p-n junction type that convert solar energy directly into electricity by means of the photovoltaic effect.

Electrochemical batteries have supplied electrical power for a number of the satellites and probes launched by the U.S.A. and U.S.S.R. Their main drawback has been that the energy capacity is limited. For long time, high-power applications, the weight of primary battery systems will be prohibitively large. The solar cell-chemical battery combination, however, first used on Vanguard I, has proven to be a very reliable source of electrical power over long periods of time at current power levels. The ability of solar power to provide intermittent communications from millions of miles out in space was recently demonstrated by the transmitter system of the Pioneer V vehicle launched in March 1960.

Unfortunately, there are some significant limitations involved in the use of solar cells that will preclude their use for many of the advanced power requirements. First, as power level is increased, solar cell systems will require orientation control in order to avoid high specific weights. However, even with oriented structures, the specific weight and surface area associated with the solar cell-chemical battery combination will make that system impractical for the higher end of the power requirement spectrum. Furthermore, there will be special missions or situations that might preclude the use of conventional solar cell systems; e.g., low-altitude orbits (drag effect), hard landings (fragility), long-time erosion effects (micrometeoroids and radiations), long shadow-time operation (lunar powerplants), and opaque high-temperature atmospheres.

Since primary chemical batteries and solar cell-chemical battery combinations are not attractive for supplying large amounts of electrical power for long periods of time, it is necessary to look to other power conversion systems that might satisfy the anticipated power requirements.

#### Advanced Systems

In investigating advanced power conversion systems for use in space, it is necessary to survey the major energy sources and conversion techniques that might be capable of producing electrical power. For use in space, three energy sources, namely, chemical, solar, and nuclear, are of primary interest. Tied in with these energy sources are many possible direct and indirect conversion methods. Figure 4 shows graphically some of the more promising conversion methods that are being used or considered for use with these three energy sources. First, let us consider some of the major characteristics of the energy sources, and then we will briefly describe the conversion techniques.

Energy sources. - (1) Systems based on chemical energy sources utilize the energy released in a chemical reaction to produce useful electrical power.

As such, they are basically stored energy systems, and therefore can provide only a fixed product of power and time. Power level and lifetime are thus inversely related for these systems. However, chemical energy systems can be recharged either through replacement of reactants or regeneration of reactants from the reaction products.

(2) The power density available from solar energy is fixed and varies inversely with the square of the distance from the sun. (At earth distance, the available power is 125 w/sq ft(430 BTU/hr)/sq ft.) Power level and lifetime are therefore basically independent. Solar energy may be utilized directly (solar cell) or it may be converted to thermal energy and then used. When solar energy is used as a heat source, reflectors are necessary to collect and concentrate the solar radiation. The principal characteristics of solar energy are the need for a power storage system when the solar radiation is cut off, as in the case of the shadow of the earth, the need for comparatively large energy-gathering surfaces, and the need for some form of orientation control to keep these surfaces properly aligned.

(3) Nuclear energy is a compact source of power. It is available from two sources, namely, nuclear fission and radioisotope decay. In both cases, the energy is available in particulate, radiative, or thermal forms. Fission reactors have an advantage for advanced systems in that sizable increases in power level can be obtained with only moderate increases in reactor size and weight. The useful life of a nuclear energy source, however, is limited - for the reactor, by the burnup of the fissionable products, and for the radioisotope, by its half-life. Another characteristic of nuclear energy sources is the shielding against emitted radiations that will be required for instruments and personnel.

Conversion methods. - In figure 4, the conversion devices on the left, namely, the conventional electrochemical battery and the solar photovoltaic

cell, are the currently used systems described previously. Advanced methods are indicated by the configurations on the right of the figure. Detailed descriptions and discussion of these power conversion systems may be found in [9 to 16].

(1) the principal electrochemical conversion device under consideration for advanced systems is the fuel cell. The fuel cell is basically a battery based on a steady flow of fuel and oxidant such as hydrogen and oxygen. Fuel cells can be used as either a "one-shot" primary power source or as a regenerative power source utilizing solar- or nuclear-energy regeneration of the fuel cell products. Regeneration can be accomplished either by thermal or particulate dissociation. The principal advantage of the fuel cell is its potentially greater power output per unit weight compared to the conventional chemical battery. Also, like the conventional chemical battery, it has no rotating parts and is essentially free of vibration. Unlike the chemical battery, however, the fuel cell is in a preliminary development stage.

(2) Electromechanical conversion devices utilize a heat engine to drive an electric generator. Currently, the principal type of heat engine under consideration is the steady-flow turbine using a working fluid heated by solar or nuclear energy. These systems, which are referred to as turbine-generator devices, are characterized by large rotating machinery components and the need for a separate radiator component to reject the cycle waste heat. Turbine-generator devices may also be used in conjunction with a chemical energy source for short-time applications. In these systems, the turbine is driven by the combustion of fuel and oxidant such as hydrogen and oxygen, or by the decomposition of a monopropellant such as hydrogen peroxide. Due to existing technology on their components, turbine-generator systems for use in space are in active states of development. Operating units using nuclear and chemical energy have already been built and ground tested.



(3) Thermoelectric devices are basically arrays of couples made of pairs of dissimilar semiconductor materials. One junction between the dissimilar elements is heated while the other is cooled. Electricity is produced directly as a result of the imposed difference in temperature between the hot and cold junctions by means of the Seebeck effect. Heat for these systems may be supplied from either solar- or nuclear-energy sources. The principal advantage of thermoelectric systems is their simplicity, ruggedness, and complete freedom from vibration. Thermoelectric devices have been built and proven and are currently available for space use with an radioisotope energy source. These systems, however, have comparatively low efficiencies and high specific weights.

(4) Systems based on the thermionic emission principle obtain their electrical current directly from the emission of electrons from a heated cathode and their subsequent collection by a cooled anode. Heat to the cathode may be supplied from either solar or nuclear sources. In principle, these systems should be relatively simple and free of rotating components. The thermionic converter is a relatively new concept for space power applications and is currently under intensive research.

#### Comparisons

The effectiveness or the desirability of a given power conversion system for a specific application will depend primarily upon its weight, its surface area, and its reliability for the intended mission lifetime and power level. The importance of low weight for the power supply system is obvious in view of the payload limitations of the available launch vehicles. Low specific weight is especially essential for electric-propulsion vehicles. Consideration of the surface areas associated with collector or radiator components is important, since excessively large area requirements will make a system impractical. The necessity of reliability and continuous trouble-free operation is likewise clear. Other considerations that may enter into a comparison of systems are

such factors as gyroscopic effects, starting and restarting, orientation control, vulnerability to meteoroid damage, and ability to withstand shock and impact.

Let us now roughly compare the major power conversion systems on the basis of the four major factors of reliability, weight, lifetime, and power level.

First, as far as reliability is concerned, it is recognized that, in principle, reliability will be enhanced for systems that are relatively simple or have a large useful background of related technology. However, not very much can be said with assurance about a system's reliability until it has been built and tested.

Second, preliminary estimates of the characteristics of the major power conversion types considered have shown that each system has a best range of application as far as the weight and time requirement are concerned. Figure 5 shows a comparison of a calculated range of specific weights in pounds per kilowatt for each major system as a function of the lifetime available or required. It is clear from figure 5 that primary systems based on chemical energy sources (the battery, the fuel cell, and the chemical turbine-generator) are comparatively high in specific weight except for short-time applications. For long-term application, it is seen that advanced systems based on solar and nuclear energy appear most promising, with the prospects of somewhat better specific weights attainable from the nuclear systems.

General comparisons among the power systems can also be made on the basis of power level. As power level increases, the physical surface areas required to dissipate waste heat or to collect solar energy may be so large as to introduce containment, packaging, and assembly difficulties as well as structural complexity and orientation control problems. Current solar cells of about 10-percent efficiency require about 80 square feet for each kilowatt of power

output. Solar reflectors likewise have comparatively large area requirements. Even for the theoretically ideal case of perfect alignment and no losses in either the reflector or the receiver, solar reflector specific frontal areas of about 40 square feet per kilowatt will be required for systems with a cycle efficiency of 0.20. The area requirements of actual systems, of course, will be somewhat larger. Conversion devices based on solar energy, therefore, will probably be restricted to low (less than 1 kw) or moderate (about 1 to 100 kw) power levels.

The area requirements for radiating waste heat are considerably less severe than for collecting solar heat at high power and temperature levels. For example, for a cycle efficiency of 0.20, specific radiator areas will be around 3 square feet per kilowatt at a radiator temperature of  $1400^{\circ}$  R ( $778^{\circ}$  K) and around 1 square foot per kilowatt at  $1800^{\circ}$  R ( $1000^{\circ}$  K). Thus, nuclear energy sources, which require only radiating areas, should be more practical for the high power levels (100 kw and up). In this respect, reference is made to nuclear fission energy since limitations on inventory size as well as specific weight considerations will restrict radioisotope systems to power levels below about 1 kilowatt.

It is clear, therefore, from all these considerations that, for long-time missions at power levels of the order of a few kilowatts and up, power systems based on nuclear energy (fission reactor) or solar energy (nonphotovoltaic) are most promising. Furthermore, of the many possible conversion devices that can be used with solar and nuclear energy sources for these requirements, currently only the turbine-generator system and the thermionic emitter system appear attractive for low specific weights. Consequently, considerable effort is being expended in the U.S.A. on the research and development of these systems. Logically, then, this paper will discuss in some detail both the turbine-generator and the thermionic emitter systems.

## Turbine-Generator System

Two general types of thermodynamic cycles may be used for nuclear and solar turbine-generator systems: the Brayton gas cycle employing an inert gas such as helium or argon as the working fluid, or the Rankine cycle employing mercury or one of the alkali metals (rubidium, sodium, potassium) as the working fluid. The working fluid picks up its heat from the reactor or from the receiver of a solar collector. For the Brayton cycle, a large multistage gas compressor will be needed, while for the Rankine cycle only a condensate pump is required.

The large powers consumed by the gas compressor result in comparatively low cycle efficiencies. These low cycle efficiencies are evidenced in the considerably larger specific radiator areas required by the gas cycle compared to the vapor cycle. For example, figure 6 shows comparative curves of required specific radiator area against the ratio of radiator-inlet to turbine-inlet temperature. (The curves for the Brayton cycle are optimized for ratio of radiator-inlet to -outlet temperature.) For the given advanced turbine-inlet temperature of  $2500^{\circ}$  R ( $1390^{\circ}$  K), the minimum radiator area for the gas cycle is about six times that of the vapor cycle. If the use of an inert gas such as helium will permit operation at a turbine-inlet temperature of  $3500^{\circ}$  R ( $1945^{\circ}$  K), the required radiator area for the gas cycle is reduced considerably, but it is still about twice that required for the vapor cycle. As a consequence, only the vapor cycle is currently considered as a promising system.

A schematic diagram of a typical current system using a Rankine mercury vapor cycle and a nuclear reactor heat source is illustrated in figure 7. The principle of operation of the turbine-generator system is as follows: liquid sodium-potassium alloy in the primary loop is heated in the reactor and its temperature is raised to about  $1300^{\circ}$  F ( $704^{\circ}$  C). The sodium-potassium alloy then passes through a boiler where it supplies heat to vaporize the mercury in

the secondary loop. The two-loop system shown is used mainly because the high nuclear cross section of mercury prohibits its use in a thermal reactor. The radiation shield required to shield the payload and prevent activation of the mercury in the secondary loop is placed between the reactor and the boiler. The mercury vapor from the boiler enters the turbine at 1200° F (649° C) where it is expanded so that its temperature drops to 560° F (293° C). The vapor from the turbine is condensed in the radiator, and the resulting waste heat is rejected to space by thermal radiation. The liquid mercury is then pumped back to the boiler to complete the cycle.

In general, the turbine-generator system may involve a single loop, a double loop, as in the illustration of figure 7, or a triple loop. A third loop may be introduced if the vapor is condensed in a separate unit and a liquid coolant loop is provided between the condenser and the radiator.

The principle of operation of a solar turbine-generator system is similar except that the reactor and shield are replaced by a solar collector which is used to supply heat to the boiler. In this case, the need for separate heating and working loops arising from the activation problem is no longer present.

The question of radiator area is an important one in the evaluation of turbine generating systems because of the very large weight associated with the radiator component. The radiator areas may be reduced by first making the turbine-inlet temperature as high as possible; second, by keeping the radiator temperature close to its optimum value; and third, by maintaining component efficiencies as high as possible. The optimum ratio of radiator-inlet temperature to turbine-inlet temperature is about 0.75 for high turbine efficiency [16]. As far as turbine-inlet temperatures are concerned, it is recognized that the maximum temperatures will be limited by corrosion due to the working fluids and by material strength properties.

In this connection, it should be pointed out that cycle operating temperatures will also influence the choice of the vapor working fluid. Each range of operating temperatures considered for the vapor cycle has a best working fluid which will be determined from consideration of the vapor pressures of the fluid in this temperature range. For example, mercury cannot be used at a turbine-inlet temperature of  $2500^{\circ}$  R ( $1390^{\circ}$  K) because of its high vapor pressure (5400 lb/sq in.). On the other hand, at a lower turbine-inlet temperature such as  $2000^{\circ}$  R ( $1110^{\circ}$  K), the vapor pressure of sodium is so low as to practically exclude its use as a cycle working fluid. In general, from the vapor pressure point of view, mercury may be most suited at a turbine-inlet temperature around  $1600^{\circ}$  R ( $890^{\circ}$  K), rubidium around  $1900^{\circ}$  R ( $1055^{\circ}$  K), potassium around  $2200^{\circ}$  R ( $1222^{\circ}$  K), and sodium around  $2500^{\circ}$  R ( $1390^{\circ}$  K).

Among the many problems associated with the design of turbine-generator systems for use in space are: reliability (these systems may have to operate unattended or without maintenance for long periods of time); space stabilization problems (gyroscopic moments); the large radiator areas required to reject waste heat; the nuclear radiation problem associated with the nuclear systems; the large solar collector areas and energy storage problems associated with the solar systems; and, perhaps most important of all, the lack of information on meteoroid damage to the fluid-carrying parts of the system, especially the radiator. Most of these problem areas are currently being investigated. In particular, in the near future the NASA plans to send additional experiments into space to explore the meteoroid hazard more fully.

At present, two nuclear reactor turbine-generator systems are being developed in the U.S.A. The first system, initiated in 1956 and designated SNAP 2 (SNAP = Systems for Nuclear Auxiliary Power), is designed to supply 3 kilowatts of auxiliary electrical power and is in an advanced state of development [17]. The second system, SNAP 8, which was illustrated in figure 7, was

initiated jointly by the NASA and AEC early in 1960. SNAP 8, producing 30 kilowatts of electrical power, will be used to supply both auxiliary power and primary propulsion power for the first flight test of an experimental ion engine. In addition to the nuclear systems, two solar-powered turbine-generator systems are being developed. These systems, called SPUD I and SUNFLOWER I, will supply 1 kilowatt and 3 kilowatts of electrical power, respectively. All the turbine-generator systems just mentioned employ a Rankine vapor cycle which uses mercury as the working fluid.

#### Thermionic Converter

The thermionic converter is simply a heat engine which uses electrons as the working fluid. In its simplest form, a thermionic converter is a vacuum or gas-filled device with a hot cathode to emit electrons, a cold anode to collect the electrons, a suitable envelope, and two electrical leads. The operation of the thermionic converter is similar to that of the vacuum-tube diode found in radios except that there is no applied potential between the electrodes.

The simplicity of the thermionic converter for use as a space power generating system can be observed in figure 8(a) where a schematic diagram of a thermionic converter is shown. Either solar or nuclear energy may be used to supply heat to the cathode, and the waste heat from the anode is rejected to space by thermal radiation either directly from the anode surface or indirectly by means of a coolant loop and radiator.

Let us review the operation of the thermionic converter in more detail by referring to figure 8(b), where the energy of the electron at various locations in the diode is illustrated. The abscissa is distance and the ordinate is electron energy.

Imagine that the Fermi level is the energy surface of the electrons in a metal. Heating the cathode causes some of these electrons to be lifted over

the work-function barrier at the surface of the cathode into the vacuum. This process is analogous to the vaporization of liquids, in which the latent heat of vaporization must be supplied to the liquid to boil off molecules of vapor. The lower the work function, the easier it is for electrons in a hot metal to escape. Electrons from the hot cathode travel to the cold anode by virtue of their kinetic energy. From the anode, they then flow back to the cathode through an external load. Because electrons are charged particles, however, they produce a space charge in the region between the cathode and the anode, and this tends to limit the number of electrons that can flow to the anode.

The two most promising methods for reducing the space charge formation are by introducing positive ions between the cathode and anode and thus neutralizing the space charge (cesium is being used for this purpose), or by having the cathode and anode extremely close together. Both of these methods for overcoming the space-charge barrier are being developed in the U.S.A.

The use of thermionic converters with nuclear reactors is extremely attractive for space applications. One possible nuclear reactor application for the thermionic converter is that wherein the converter is placed inside the reactor. In this case the surface of each reactor fuel element would be the electron-emitting surface of the thermionic converter, and the anode would be cooled by the reactor coolant.

To give some idea of the operating characteristics of thermionic converters, some general statements can be made. First, the minimum cathode temperatures that can be used for gas-filled or vacuum converters are about  $1700^{\circ}$  and  $1300^{\circ}$  K, respectively. Second, for minimum specific radiator area, the anode temperature should be about 0.75 times the cathode temperature. Third, the current laboratory power output of the converter is about 1 to 10 watts per square centimeter of cathode area. The efficiency is about 5 to 10 percent.



The principal advantages of the thermionic converter are: the absence of large rotating machinery components; the possibility of rejecting waste heat directly from the anode surfaces; or, if a separate cooling loop and waste-heat radiator are necessary, the required surface areas will be smaller than for the turbine-generator for comparable overall efficiencies. This is due to the higher reject temperatures of the converters (greater than about 1270° K and 975° K, respectively, for the gas-filled and vacuum cases) compared to the turbine-generator. There are some problems, however. Corrosion difficulties may be encountered if it becomes necessary to use a separate heating or cooling loop (min. temperatures of the converter cycle are of the same order as the max. temperature of the turbine-generator cycle.) In addition, the close spacing between the cathode and anode required for the vacuum converter (about 0.0005 in.) and the gas-filled converter (about 0.050 in.) may present serious fabrication problems. Because of the low voltage output of the converter (of order 0.5 v), many converters would have to be placed in series in order to produce a high output. And, of course, the high-temperature requirements will present severe materials, insulation, and sealing problems.

#### ENERGY STORAGE SYSTEMS

In addition to the primary power systems necessary to provide the continuous power requirement, space vehicles may also require some form of energy storage system. Stored energy may be necessary in all cases to provide emergency power in the event of main power failures, or to provide short-time pulse power for peak loads. The principal need for stored energy, however, rests in the conversion systems using solar energy. The need for energy storage to supply power during the shadow time of solar-powered earth satellites is obvious. Power for shadow-time operation may also be required for orbital launched solar electric propulsion vehicles if a nontwilight orbit is used for the escape trajectory.

Emergency power requirements and to some extent pulse-power requirements can best be met by the use of primary batteries such as the conventional chemical cell, the fuel cell, or the chemical turbine-generator, as discussed previously. For main power requirements, however, some regenerative energy storage system will be necessary. There are currently two principal methods for regenerative energy storage: (1) electrochemical storage and (2) thermal (fusion) storage. Electrochemical energy storage can be accomplished by means of conventional secondary chemical batteries or the regenerative fuel cell which are charged during the sun cycle. In a thermal storage system, a heat-absorbing medium such as a metal hydride (like lithium hydride) or a metal (like beryllium) is used to store heat from the solar receiver for later release as the powerplant heat input.

The following points can be made about storage systems: They impose an obvious penalty on electric powerplants because they add additional weight to the system. Electrochemical storage systems impose further penalty on the power generation system since the capacity and consequently the weight of the main powerplant must be increased to supply the charging power as well as the main continuous power demand. Thermal storage does not require an increase in main powerplant capacity, but it does require an increase in the solar collector area. Thermal storage systems can only be used in conjunction with a "heat engine" power generation system. For heat engines, thermal storage can permit continued operation of the main powerplant during the shadow time.

Comparisons of the specific weights of electrochemical and thermal storage systems can best be made by considering an example. Assume that the storage system is required to provide shadow-time electrical power equal to sun-time electrical power for a time period of 1 year. In addition, assume the electrical power is required for a satellite vehicle in a 90-minute orbit with a

shadow time of 36 minutes. For an electrochemical storage system, it will be necessary to use batteries of long-cycle life like the nickel-cadmium cells having a specific power of about 12 watt-hours per pound. (The silver-zinc cell has a specific power of about 60 w-hr/lb, but at present it has a short-cycle life.) Thus, by using a storage efficiency of 1.0 and a drain factor (fractional discharge) of 0.10 of the cell capacity (this is required for long cycle life), the specific weight of the nickel-cadmium storage system is calculated to be 500 pounds per kilowatt of sun-time power.

For the thermal storage system, consider the use of lithium hydride which has an estimated heat of fusion of from 1100 to 2000 Btu per pound and a melting temperature of 1256° F (680° C). Thus, for a thermodynamic cycle efficiency of 0.15, a storage efficiency of 0.80, a 100-percent increase in required material weight to allow for shrinkage and cycling problems and to keep the temperature into the conversion device as high and constant as possible, and a structure weight of 50 percent of the lithium hydride material weight (the structure includes the material container, thermal shield, insulation, and heat-exchange components), the total specific weight of a lithium hydride storage system might be of the order of 7.5 to 13.6 pounds per kilowatt of sun-time power. If beryllium, which has a heat of fusion of 144 Btu per pound and a melting temperature of 2340° F (1280° C) can be used (there may be serious containment problems involved), the total specific weight might be about 92 pounds per kilowatt. Therefore, within the limitations of the assumptions involved, thermal storage systems, in principle, should be capable of producing significantly lower specific weights than the chemical battery system.

As indicated previously, the use of a storage system will require an increase in total powerplant capacity for electrochemical storage or an increase in solar collector area for thermal storage, compared to that necessary to

supply the sun-time power requirement. The increase in total powerplant capacity and the increase in solar collector area will both depend on the ratio of shadow time to total orbit time and on the desired average power level during the shadow time. For the examples considered, the required increase in powerplant or collector area will be about 68 percent. However, the additional weight penalty will be smaller for thermal storage than for electrochemical storage, since the collector weight constitutes only a part (about 25 to 30 percent) of the total powerplant weight.

It is thus seen that, as far as power system total weight is concerned, the thermal storage system has a double advantage over the electrochemical system in that the required increase in powerplant weight will be less, and the weights associated with the energy storage materials will be less. However, it should be pointed out that the thermal storage schemes considered are as yet undeveloped, and no indication of their reliability or operational problems is available.

#### SYSTEM SPECIFIC WEIGHT

Now that some of the general characteristics of the more promising power conversion and energy storage schemes have been described, it might be well to obtain a more detailed indication of the magnitude of the specific weights associated with complete power generation systems. Representative variations of system specific weight with power level are shown in figure 9 for various nuclear and solar energy systems. (Primary chemical energy systems are not included because their relatively short lifetimes render them inapplicable for advanced missions.) The curves presented are based for the most part on analytical studies and system designs available in the literature. They are therefore estimated values indicative of general trends and comparisons. Systems under actual development are identified by symbol points.

First, let us consider the power range from 0.1 to 1.0 kilowatt. The solar system curves are shown both with storage and without storage, and the nuclear system curve is for an unshielded reactor. The solar cell weight of 80 pounds per kilowatt is based on current technology with a conversion efficiency of 0.10 at the temperature of operation, a cell assembly (solar cell, coatings, diodes, glass slides, and supporting structure) weight per square foot of 1.0 pound, and perfect orientation. The addition of storage to the solar cell in the form of nickel-cadmium storage batteries with a 10 percent drain increases the system weight to 633 pounds per kilowatt. In this case, the required increase in power capacity raises the solar cell weight to 133 pounds per kilowatt. If the solar cells are unoriented (as for example in the case of the paddlewheel arrangement on some of the U.S. satellites), the cell weight might be increased by a factor of about five so that the total system weight will be increased to about 1165 pounds per kilowatt. The solar thermionic systems are shown both with nickel-cadmium battery storage and with beryllium thermal storage. The weight increases for storage for the solar systems were based on the assumptions discussed previously for full power during the shadow time of 36 minutes in a 90-minute orbit.

The weights for the nuclear thermoelectric systems are for unshielded configurations. (The symbol on the isotope curve represents the SNAP 1a system and the symbol on the reactor curve is the SNAP 10 system.) With shielding for electronic instruments, the system specific weights will be greater than for the solar cell-chemical battery system. This clearly indicates the marked weight penalty imposed on nuclear systems in this low-power range by the comparatively high specific weights of the nuclear energy source and the radiation shielding. It is also seen in the figure that the solar thermionic system with thermal storage (beryllium was used) has promise for providing a low-weight system. However, the solar cell-chemical battery system might also be

competitive if with further development the efficiency of the solar cell can be raised to 16-percent and the storage battery and the drain factor can be doubled. In this case, the system specific weights will be around 330 pounds per kilowatt for oriented configurations with the same weight per square foot of cell area. Curves for the regenerative fuel cell, which would be applicable in this low-power range, were not presented because of the sparse information available on the variation of weight with power level of these systems. (Specific weights of regenerative fuel cell systems are expected to be in the 500 to 1000 lb/kw range.)

In the power range from about 1 to 10 kilowatts, the turbine-generator and the reactor thermionic systems enter the picture. For the solar turbine-generator curve, the symbol represents the Sunflower I system, and the thermal storage was computed for lithium hydride. The symbols for the reactor turbine-generator represent the SNAP 2 system. In this power range, the systems included are approximately competitive, with the reactor thermionic showing promise of a comparatively low specific weight.

For powers greater than 10 kilowatts, only the reactor turbine-generator and the reactor thermionic systems appear competitive. The shaded band presented for the reactor turbine-generator represents the consensus of values obtained from over two dozen system analyses. (Only a comparatively few studies were available for the other systems.) The symbol points at 30 kilowatts represent the SNAP 8 system. In general, the upper curve is considered characteristic of current technology, while the lower curve might be representative of advanced technology. The single line for the reactor thermionic also indicates an advanced technology since at present the converter is only in a laboratory stage of development. The decreasing trend of specific weight with power level is a reflection of the general reduction in component (primarily reactor) specific weight and increase in component efficiency.

The reactor system curves in figure 9 are for unshielded powerplants. The amount of shielding necessary for a given system will depend on the vehicle mission and configuration. Some indication of the shielding requirements for protection of electronic equipment can be obtained from the circled symbols at 3 and 30 kilowatts. Shielding requirements for personnel protection will be substantially larger. In both cases, however, the relative penalty in system specific weight due to shielding requirement will tend to decrease as power level is increased.

#### CONCLUSIONS

Space power generation systems based on chemical, solar, and nuclear energy sources have been compared on the basis of system specific weight, electrical power level, and mission lifetime. For power levels between about 0.1 and 1.0 kilowatt, solar cells, solar thermionic, and isotope thermoelectric systems are competitive. Between about 1.0 and 10 kilowatts, solar and reactor turbine-generator and reactor thermionic systems are competitive. For power levels greater than about 10 kilowatts, only the reactor turbine-generator and thermionic systems are promising.

## REFERENCES

1. Clark, John F.: Geophysical Research Using Artificial Earth Satellites. Paper No. 60-50, IAS 28th Annual Meeting, Jan. 25-27, 1960.
2. Newell, Homer E., Jr.: NASA Space Science Program. Statement to House Committee on Science and Astronautics. U.S. Congress, Feb. 1960.
3. Newell, Homer E., Jr.: U.S., Russian Space Efforts Compared. Aviation Week, Dec. 1959.
4. Moeckel, Wolfgang E.: Propulsion Methods in Astronautics. First International Congress in the Aeronautical Sciences, Madrid, Spain, September, 1958.
5. Stuhlinger, Ernst: How Useful are Low-Thrust Space Vehicles? Astronautics, Feb. 1960.
6. Hamilton, Robert C.: Spacecraft Secondary Power Requirements During the 60's. Paper presented at AIEE Meeting, Dallas, Texas, April, 1960.
7. Cooley, William C.: A Comparison of Nuclear and Solar Power Systems for Manned Space Stations. IAS-NASA-Rand National Symposium on Manned Space Stations, Los Angeles, California, April 20-22, 1960.
8. Moeckel, Wolfgang E.: Fast Interplanetary Missions with Low-Thrust Propulsion Systems. NASA TN D-295, 1960.
9. Howard, Harris J., and McJones, Robert W.: Available Power Systems for Space Vehicles. ARS 14th Annual Meeting, Washington, D.C., Nov. 16-20, 1959.
10. Zwick, Eugene B., and Zimmerman, Robert L.: Space Vehicle Power Systems. ARS Semi-Annual Meeting, San Diego, California, June 8-11, 1959.
11. Hamilton, Robert C.: Interplanetary Space Probe Auxiliary Power Systems. ARS Semi-Annual Meeting, San Diego, California, June 8-11, 1959.
12. Proceedings of a Seminar on Advanced Energy Sources and Conversion Techniques, Vol. 1. U.S. Dept. of Commerce O.T.S. No. P.B. 151461, Nov. 1958.



13. Rosenblum, Louis.: Small Power Plants for Use in Space. Aero/Space Engineering, vol. 17, no. 7, July 1958.
14. Huth, John H.: Space Vehicle Power Plants. Rand Corp., P-1861, Dec. 22, 1959.
15. Wilson, Volney C.: Electric Energy Sources and Conversion Techniques for Space Vehicles. IAS 28th Annual Meeting, New York, N.Y., Jan. 25-27, 1960.
16. Moffitt, Thomas P., and Klag, Frederick W.: Analytical Investigation of Cycle Characteristics for Advanced Nuclear Turbo-Electric Space Power Systems. Proposed NASA TN.
17. Anderson, Guveren M.: Snap 2 - A Reactor Powered Turboelectric Generator for Space Vehicles. Paper Presented at SAE National Aeronautic Meeting, New York, N.Y., April 1960.

## FIGURE LEGENDS

- Fig. 1. - Successful satellite and space probe launches.
- Fig. 2. - Anticipated growth of NASA's payload launching capability.
- Fig. 3. - Space power requirements.
- Fig. 4. - Electric power systems.
- Fig. 5. - Comparison of energy systems.
- Fig. 6. - Radiator area per kilowatt for turbine generator systems.
- Fig. 7. - Schematic arrangement of nuclear turbine-generator system, SNAP 8.
- Fig. 8. - Thermionic converter.
- (a) Schematic diagram of a thermionic converter.
- (b) Schematic energy diagram of a thermionic converter.
- Fig. 9. - Estimated specific weights of power generation systems.

E-924

FIGURE 1. - SUCCESSFUL SATELLITE AND SPACE PROBE LAUNCHES

NAME	ORIGIN	LAUNCH DATE	LIFETIME OR END	PAYLOAD	POWER REQ.	POWER SUPPLY	REMARKS OR EXPERIMENTS
SPUTNIK I	U.S.S.R.	OCT. 4, 1957	JAN. 4, 1958	184 LB 83.5 KG		CHEM. BATT.	RECORDED INTERNAL TEMPS. AND PRESSURES
SPUTNIK II	U.S.S.R.	NOV. 3, 1957	APR. 13, 1958	1120 LB 508 KG		CHEM. BATT.	COSMIC RAYS; SOLAR ULTRA-VIOLET AND X-RADIATION; TEST ANIMAL (DOG)
EXPLORER I	U.S.A.	JAN. 31, 1958	3 TO 5 YEARS	10.83 LB 4.82 KG	60 mw	Hg BATT.	DISCOVERED VAN ALLEN RADIATION BELT
VANGUARD I	U.S.A.	MAR. 17, 1958	2,000 YEARS	1.06 LB 0.48 KG		Hg BATT. SOLAR CELLS	TESTED SOLAR BATT.; REVEALED PEAF-SHAPED EARTH
EXPLORER III	U.S.A.	MAR. 26, 1958	JUNE 27, 1958	10.83 LB 4.91 KG	55 mw	Hg BATT.	COSMIC RAY INTENSITY; TEMPS.; MICROMETEORITE DATA
SPUTNIK III	U.S.S.R.	MAY 15, 1958	APR. 6, 1960	2134 LB 968 KG		CHEM. BATT. SOLAR CELLS	ANALYZED COSMIC RADIATION, ATMOS. COMP., ETC.
EXPLORER IV	U.S.A.	JULY 26, 1958	1 YEAR	18.26 LB 8.28 KG	30 mw	Hg BATT.	MEAS. CORPUSCULAR RADIATION
PIONEER I	U.S.A.	OCT. 11, 1958	43 HR	85 LB 37.5 KG		CHEM. BATT.	DENSITY OF MICROMETEORITES; MEAS. INTERPLANETARY MAGNETIC FIELD
PIONEER III	U.S.A.	DEC. 6, 1958	36 HR	13 LB 5.5 KG	180 mw	Hg BATT.	DISCOVERED SECOND RADIATION BELT AROUND EARTH
PROJECT SCORE	U.S.A.	DEC. 18, 1958	JAN 21, 1959	150 LB 68 KG		CHEM. BATT.	BEAMED HUMAN VOICE FROM SPACE; MESSAGES TO AND FROM GROUND STATION
MECHTA	U.S.S.R.	JAN. 2, 1959	-----	800 LB 366 KG	30 w	-----	FIRST TO REACH VICINITY OF MOON
VANGUARD II	U.S.A.	FEB. 17, 1959	200 YEARS	21.5 LB 9.76 KG		CHEM. BATT.	CLOUD COVER SATELLITE
PIONEER IV	U.S.A.	MAR. 3, 1959	-----	13.4 LB 6.08 KG	180 mw	Hg BATT.	EARTH-MOON TRAJECTORY
EXPLORER VI	U.S.A.	AUG. 7, 1959	1 YEAR	142 LB 64.4 KG	11 w CONT. 51 w MAX.	Ni-Cd BATT. SOLAR CELLS	RADIATION BELT; MAGNETIC FIELD; MICROMETEORITE; RADIO PROPAGATION
LUNAR PROBE	U.S.S.R.	SEPT. 12, 1959	IMPACT ON MOON, SEPT. 13	556 LB 259 KG		-----	IMPACT ON MOON
VANGUARD III	U.S.A.	SEPT. 18, 1959	30 TO 40 YEARS	50 LB 22.7 KG	80 mw	Ag-Zn BATT.	MEAS. MAGNETIC FIELD; INTENSITY OF SOLAR X-RAYS
LUNAR PROBE	U.S.S.R.	OCT. 4, 1959	-----	614 LB 278 KG		CHEM. BATT. SOLAR CELLS	FIRST PICTURE OF FAR SIDE OF MOON
EXPLORER VII	U.S.A.	OCT. 13, 1959	20 YEARS	92 LB 41.7 KG		Hg, Ni-Cd. SOLAR CELLS	STUDIED DIRECT SOLAR RADIATION
PIONEER V	U.S.A.	MAR. 11, 1960	-----	94.8 LB 43 KG	5 w CONT. 150 w MAX.	Ni-Cd BATT. SOLAR CELLS	RADIO TRANSMISSION TEST; RADIATION BELT; MAGNETIC FIELD; MICROMETEORITES
TIROS	U.S.A.	APR. 1, 1960	90 DAYS	270 LB 122.5 KG	18 w	Ni-Cd BATT. SOLAR CELLS	PHOTOGRAPHS OF CLOUD COVER, METEOROLOGICAL SATELLITE
TRANSIT I	U.S.A.	APR. 13, 1960	16 MONTHS	270 LB 122.5 KG	10 w 20 w MAX.	Ni-Cd, Ag-Zn SOLAR CELLS	NAVIGATION-AID SATELLITE

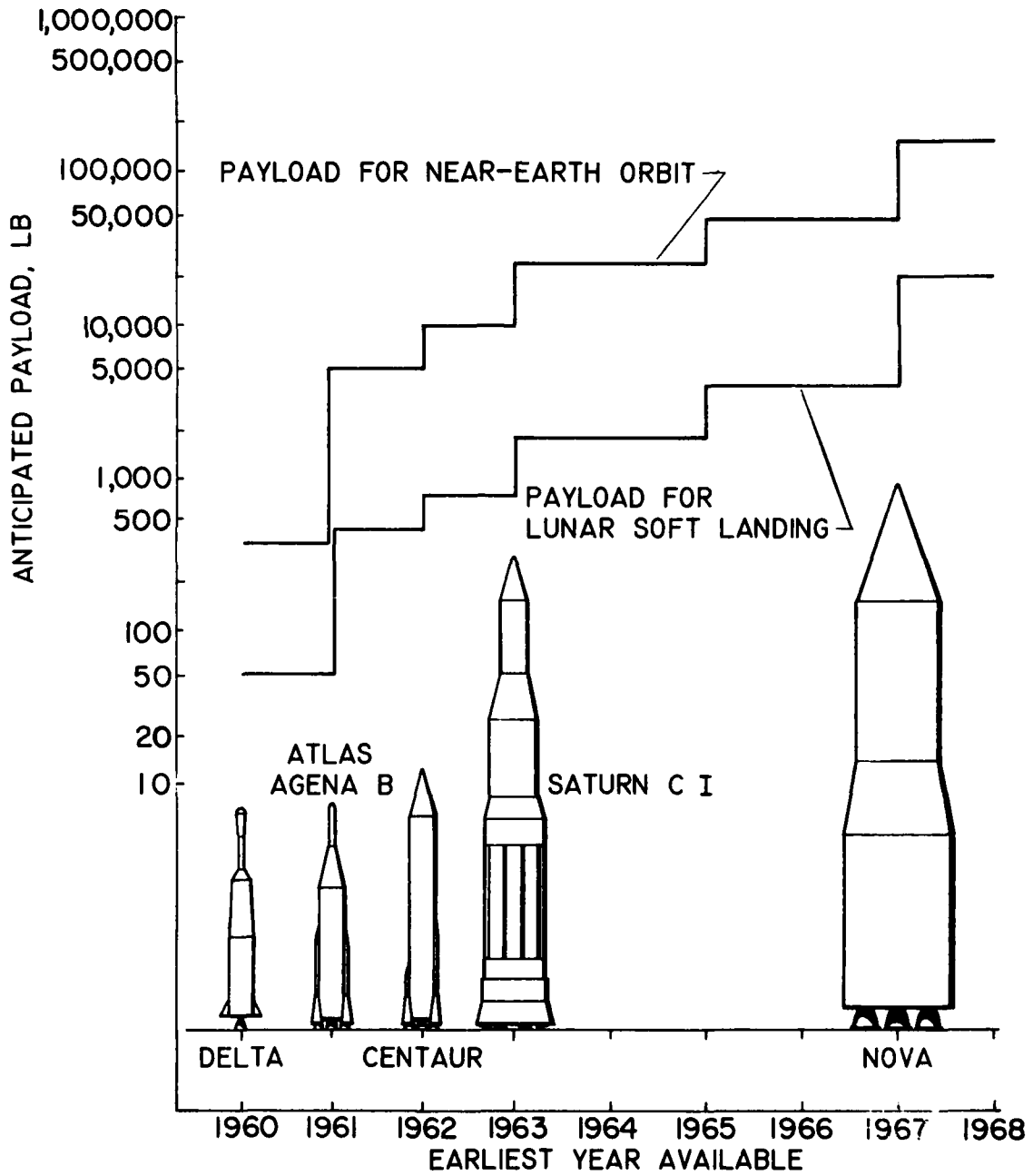

Figure 2. - Anticipated growth of NASA's payload launching capability.

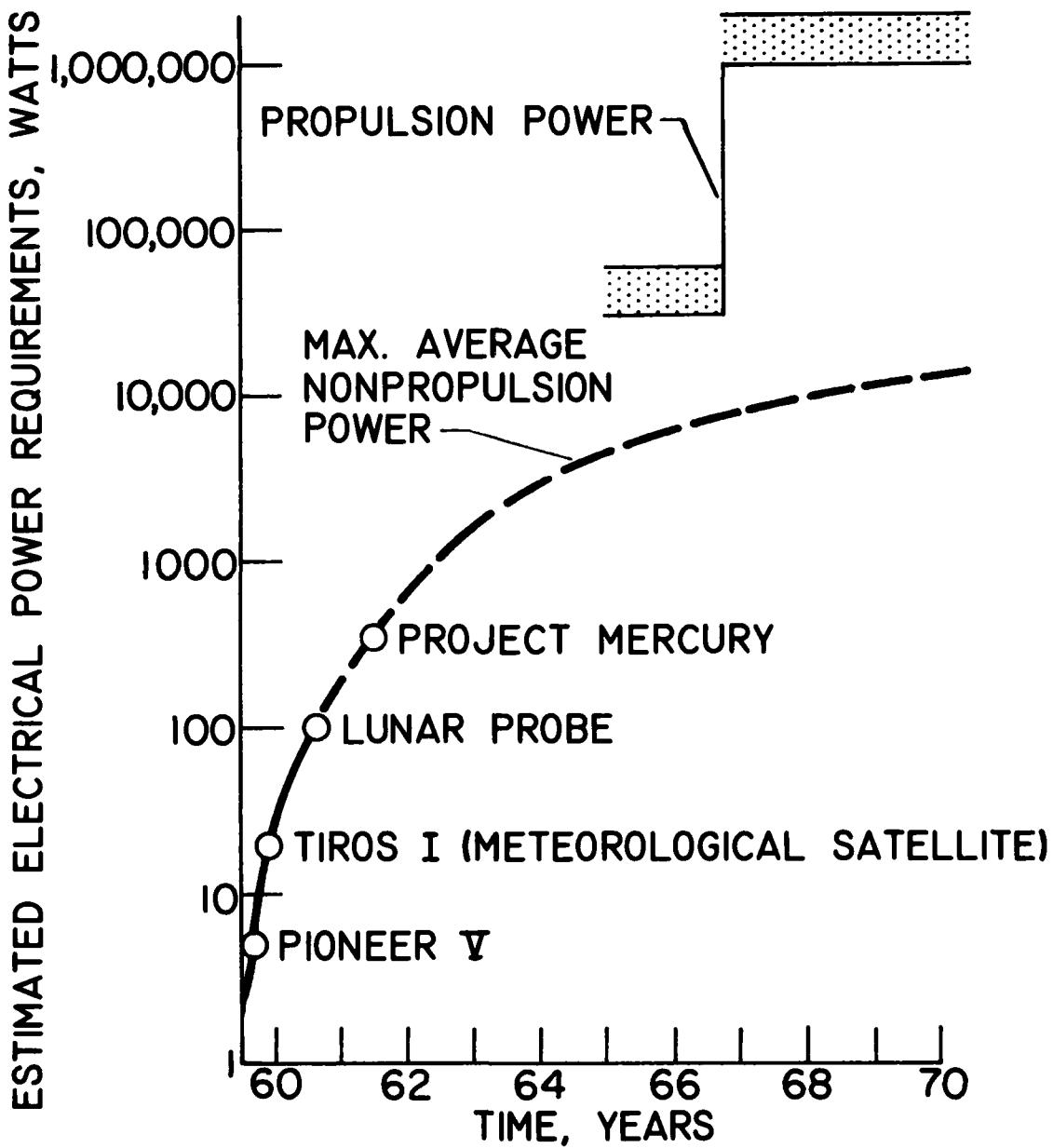

Figure 3. - Space power requirements.

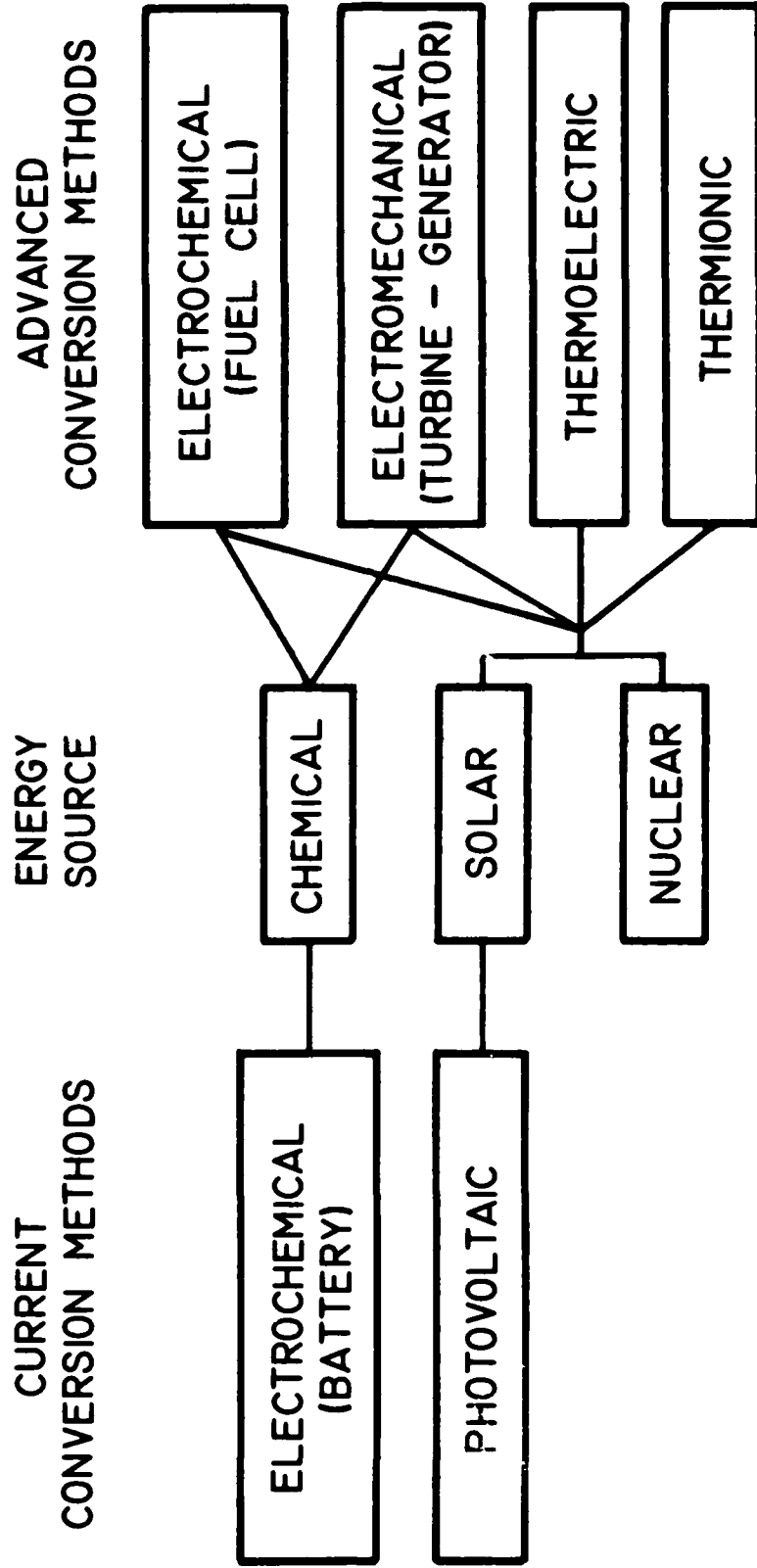

Figure 4. - Electric power systems.

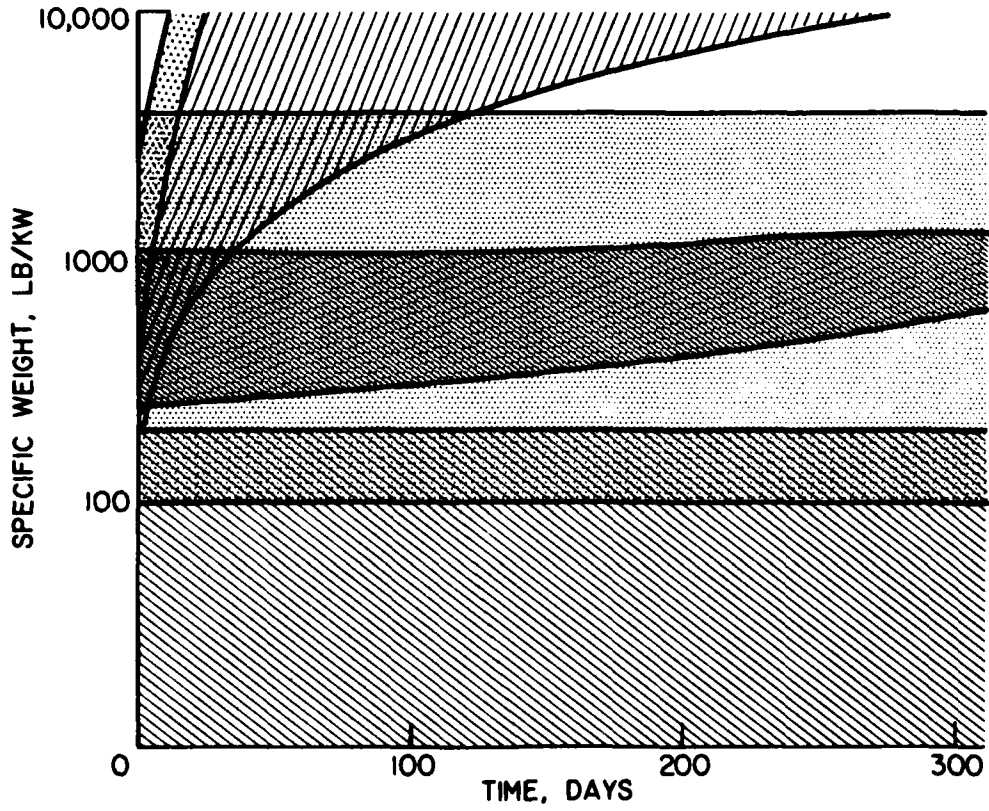
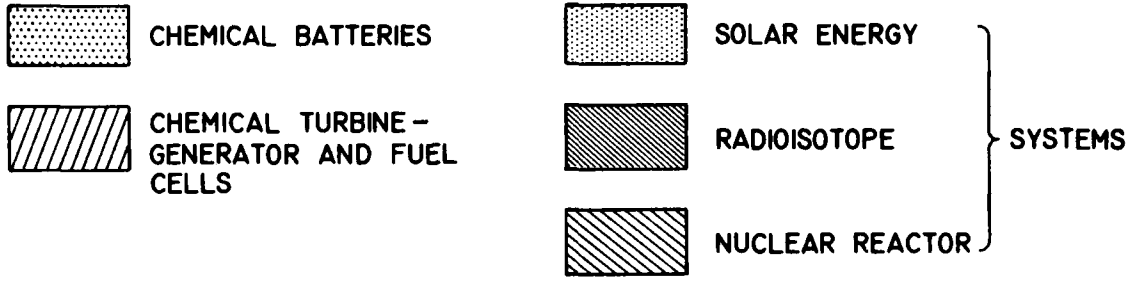

Figure 5. - Comparison of energy systems.

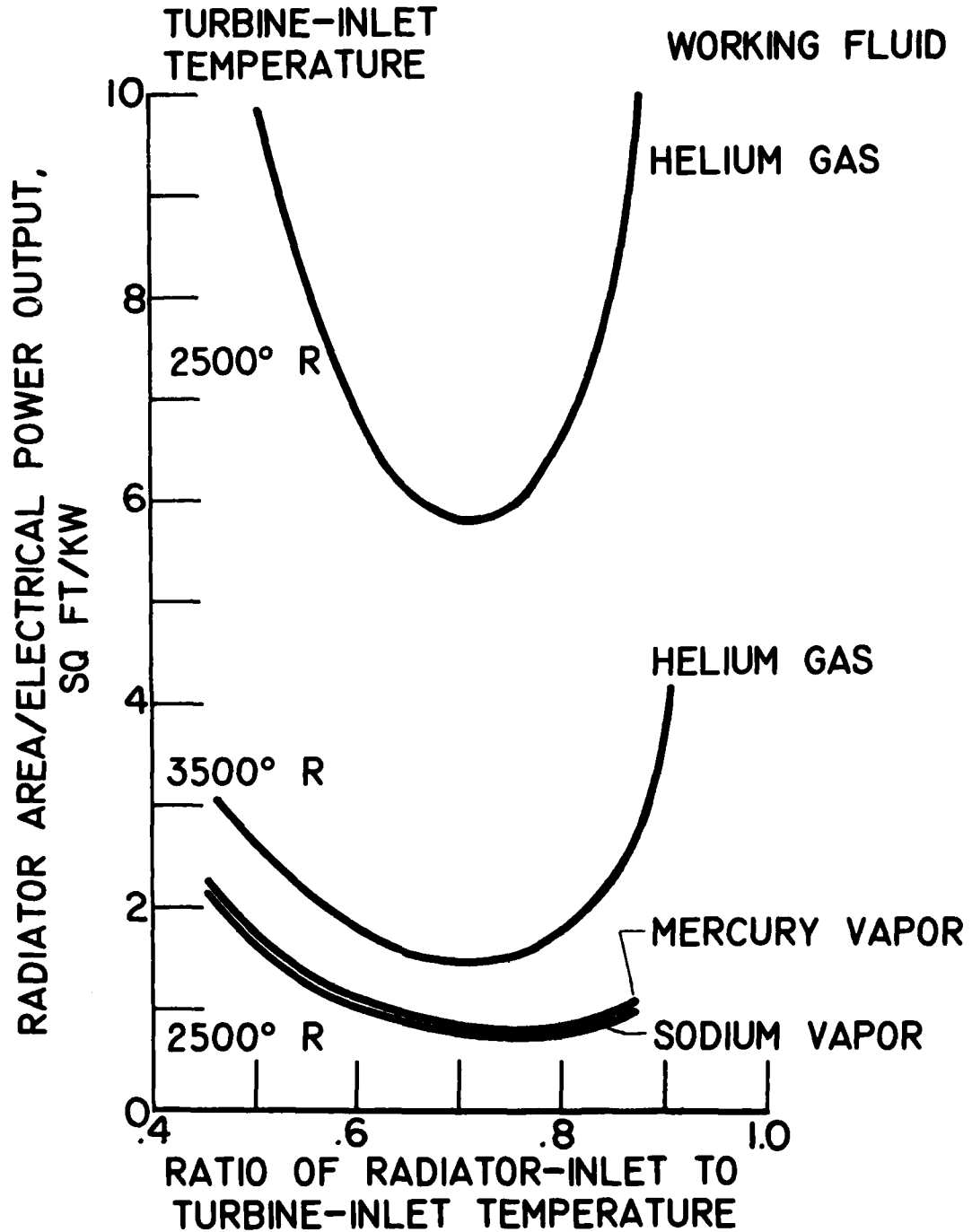

Figure 6. - Radiator area per kilowatt for turbine-generator systems.



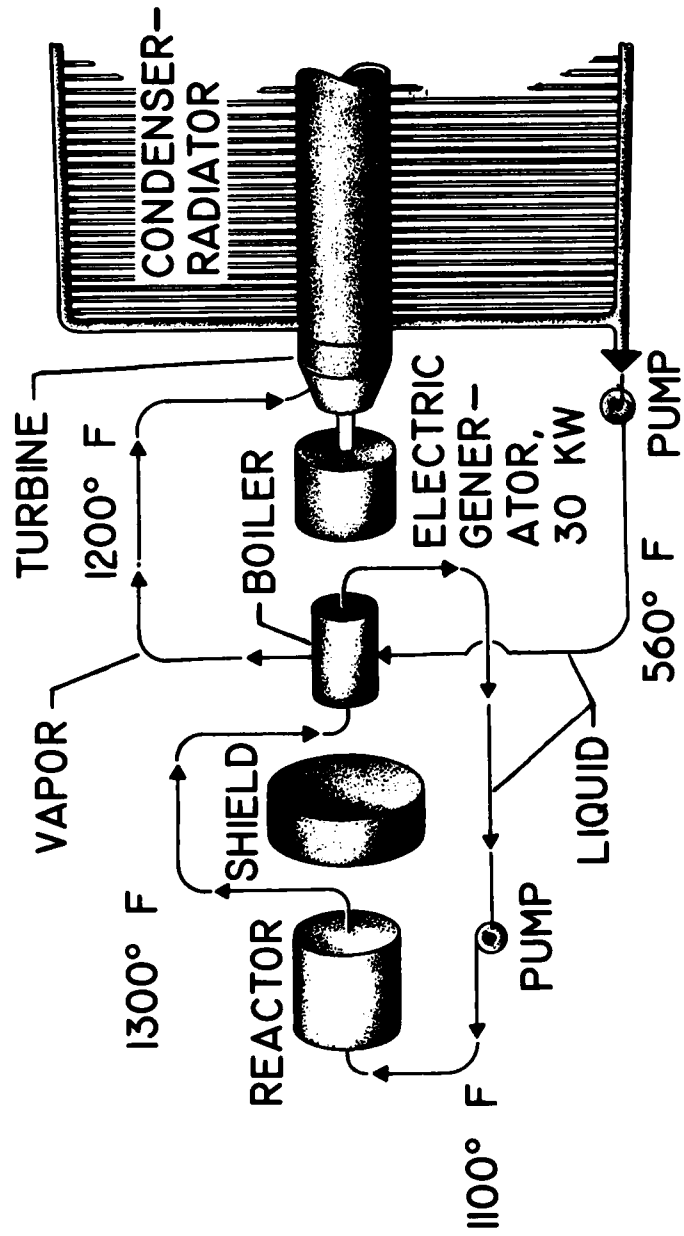

Figure 7. - Schematic arrangement of nuclear turbine-generator system (SNAP 8).

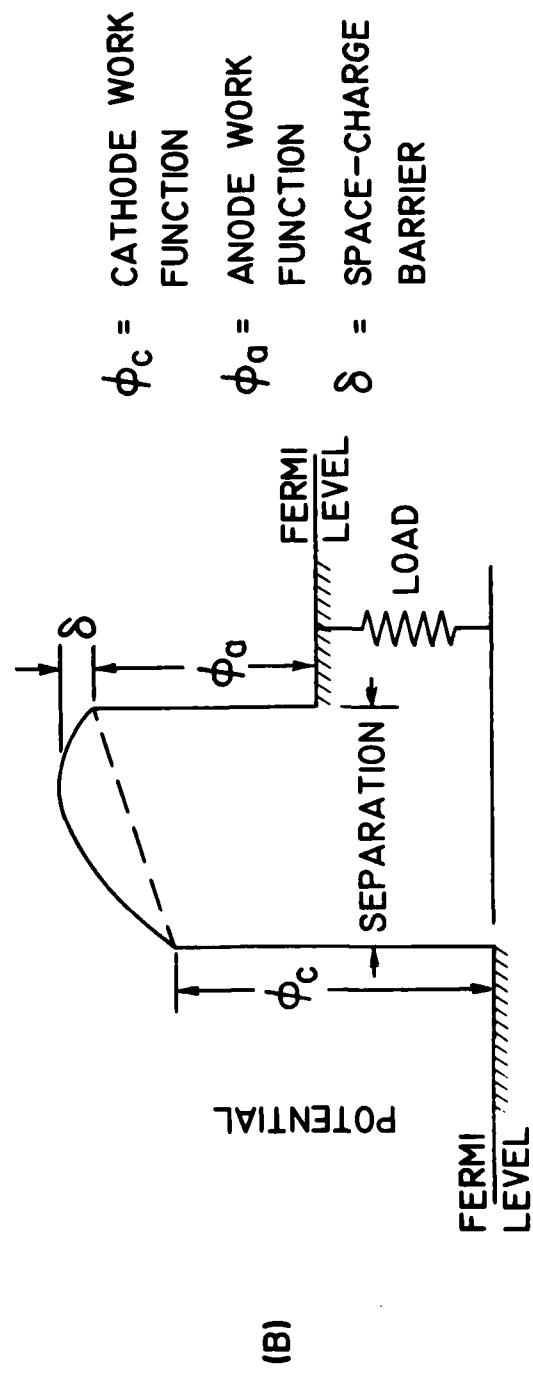
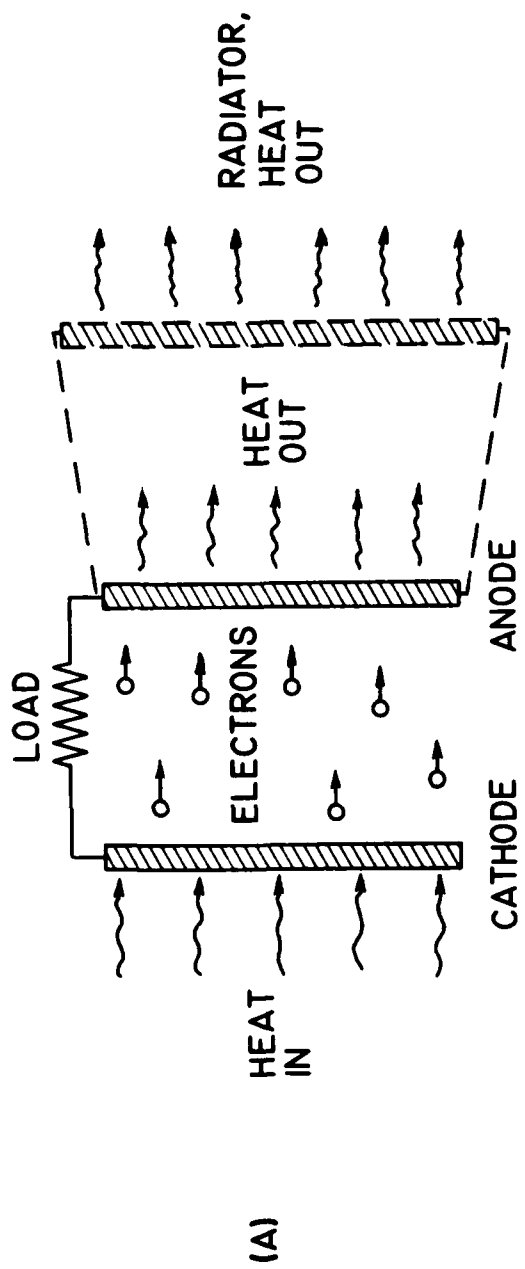

Figure 8. - Thermionic converter.