

UNCLASSIFIED

AD NUMBER

ADB029164

LIMITATION CHANGES

TO:

Approved for public release; distribution is unlimited.

FROM:

Distribution authorized to U.S. Gov't. agencies only; Test and Evaluation; JUL 1977. Other requests shall be referred to Air Force Materials Lab., Wright-Patterson AFB, OH 45433.

AUTHORITY

AFWAL ltr 21 Sep 1982

THIS PAGE IS UNCLASSIFIED

AD BO 29/64

AUTHORITY: AFWAL
1tr, 21 Sep 82



L

②

LEVEL II

AD B029164

AFML-TR-77-100
VOLUME II

RELAXED MANUFACTURING DESIGN TOLERANCE
CONCEPTS
Volume II - Appendices

General Dynamics Corporation
Fort Worth Division
Fort Worth, Texas 76101

Vol 1 30292356

JULY 1977

AD NO. _____
DDC FILE COPY

DDC
RECEIVED
AUG 10 1978
B

Final Report

April 1974 - April 1977

Distribution limited to U.S. Government agencies only;
TEST & EVALUATION; statement applied April 1977.
Other requests for this document must be referred to
Manufacturing Technology Division/LTC, Air Force
Materials Laboratory, Wright-Patterson Air Force Base,
Ohio 45433.

AIR FORCE MATERIALS LABORATORY
AIR FORCE WRIGHT AERONAUTICAL LABORATORIES
AIR FORCE SYSTEMS COMMAND
WRIGHT-PATTERSON AIR FORCE BASE, OHIO

78 07 28 020

NOTICE

When Government drawings, specifications, or other data are used for any purpose other than in connection with a definitely related Government procurement operation, the United States Government thereby incurs no responsibility nor any obligation whatsoever; and the fact that the government may have formulated, furnished, or in any way supplied the said drawings, specifications, or other data, is not to be regarded by implication or otherwise as in any manner licensing the holder or any other person or corporation, or conveying any rights or permission to manufacture, use or sell any patented invention that may in any way be related thereto.

This technical report has been reviewed and is approved for publication.

Dan L. Shunk

Capt. Dan L. Shunk
Project Engineer
Metals Branch
Manufacturing Technology Division

FOR THE DIRECTOR

H. A. Johnson

H. A. Johnson
Chief, Metals Branch
Manufacturing Technology Division

Copies of this report should not be returned unless return is required by security considerations, contractual obligations, or notice on a specific document.

UNCLASSIFIED

SECURITY CLASSIFICATION OF THIS PAGE (When Data Entered)

and cost/weight trade-off data is developed. Guidelines for relaxation of specific detail design requirements are recommended for aluminum and titanium milled parts. Measured surface roughness is shown by component test to have no correlation with fatigue life, and revised surface roughness inspection guidelines are proposed. Hand-finishing of milled parts is shown to have little or no value in extending fatigue life. Geometric stress concentrations such as notches or fastener holes are shown to dictate fatigue life.

NC programming guidelines are developed by conducting stiffener machining tests and NC programming development tests. Two F-16 production parts are re-programmed and machined and eleven pieces and the revised programming are accepted for F-16 production. Cutting time is reduced substantially.

Design guidelines are incorporated into F-16 production airframe drawings from the beginning of production. Cost records show 22% reduced hand-finishing in the factory, and a 14% total cost reduction for milled aluminum parts for 1000 F-16 aircraft is conservatively projected.

UNCLASSIFIED

SECURITY CLASSIFICATION OF THIS PAGE (When Data Entered)

FOREWORD

This final technical report covers work performed under Contract F33615-74-C-5044, "Relaxed Manufacturing Design Tolerance Concepts," from 1 April 1974 to 4 April 1977. The work was performed under the direction of the Metals Branch of the Manufacturing Technology Division of the Air Force Materials Laboratory at Wright-Patterson Air Force Base, Ohio. The original Project Engineer was Mr. John R. Williamson. The latter half of the program was under the direction of Capt. Dan L. Shunk.

The work was performed by the Fort Worth Division of the General Dynamics Corporation with Mr. Fred A. Lindstrom of the Structures and Design Department as Program Manager. Advisors included Mr. E. R. Collinsworth, Manager, Structural Design, Mr. L. M. Smith, Manager, Structures Technology, and Mr. W. D. Buntin, Director, Structures and Design. Participating team members were Mr. L. J. Hawkins, Supervisor, Manufacturing Technology, and Mr. F. P. Blanscet, Quality Control Engineer. Mr. C. E. Doyle and Mr. K. D. Mabry aided in engineering analysis and report preparation. Mr. R. L. Madarasz, Mr. U. H. Livingston and Mr. A. D. Crowe aided in programming and machining guideline development. Component testing was conducted by Mr. A. C. Shafer, and metallurgical examinations were performed by Mr. Z. R. Wolanski. Mr. J. W. Shaffer of Value Engineering advised on cost analysis and conducted implementation cost reduction analyses. Dr. W. P. Koster of Metcut Research Associates, Inc., provided valuable advice on surface integrity.

ADVISORY	
WFO	<input type="checkbox"/>
EOC	<input checked="" type="checkbox"/>
MP	<input type="checkbox"/>
AC	
DISTRIBUTION AND COPIES	
Dis.	2000 2000 of SPECIAL
B	

TABLE OF CONTENTS:
APPENDICES

APPENDIX	PAGE
A "COMPARISON PART" ANALYSIS;	1
B SHOP DIMENSIONAL SURVEY;	55
C FATIGUE TEST SPECIMEN DESIGN AND MANUFACTURING DATA;	85
D TEST SPECTRA AND STRESS LEVELS;	119
E TEST FIXTURES AND SPECIMEN LOADING;	135
F FATIGUE TEST HISTORY AND RESULTS;	165
G FATIGUE ANALYSIS OF I-BEAM SPECIMENS;	205
H STATISTICAL ANALYSIS;	217
I SURFACE ROUGHNESS REQUIREMENTS;	233
J STIFFENER MACHINING TEST DATA;	253
K NC PROGRAMMING DEVELOPMENT TESTS; and	291
L RTC REPROGRAMMING AND MACHINING OF F-16 PRODUCTION PARTS	313

PRECEDING PAGE BLANK

A P P E N D I X A
"COMPARISON PART" ANALYSIS

APPENDIX A

TABLE OF CONTENTS

	<u>Page</u>
1.0 GENERAL APPROACH TO ANALYSIS	5
2.0 MATRIX OF DESIGN COMPARISON PARTS	6
3.0 ALUMINUM NC DATA AND COST ANALYSIS	12
3.1 Matrix of Aluminum Design Comparison Parts	12
3.2 Design Comparison Parts - Data Summary	12
3.3 Cost Analysis Summary of 31 F-111 Production Parts	13
3.4 Analysis of Production Cost Factors	20
3.5 Cost Analysis of Comparison Parts	22
4.0 TITANIUM NC DATA AND COST ANALYSIS	22
4.1 Matrix of Titanium Design Comparison Parts	22
4.2 Design Comparison Parts - Data Summary	27
4.3 Cost Analysis Summary of 13 AMAVS Titanium Parts	27
4.4 Analysis of Production Cost Factors	32
4.5 Cost Analysis of Comparison Parts	32
5.0 GUIDELINES DEVELOPED	35
5.1 Aluminum Guidelines	35
5.2 Titanium Guidelines	35
5.3 Cost Analysis for Machining Two Different Corner Radii in Aluminum	35

APPENDIX A
LIST OF ILLUSTRATIONS

<u>Figure</u>		<u>Page</u>
A-1	Design Comparison Part as a Part of Production Design	7
A-2	Matrix of Aluminum Design Comparison Parts	8
A-3	Matrix of Titanium Design Comparison Parts	9
A-4	Aluminum Baseline Part Design and Alternate Details	10
A-5	Titanium Baseline Part Design and Alternate Details	11
A-6	Example of GD/FW Manufacturing Cost Data Record	19
A-7	Design Analysis Guideline No. 1, Aluminum	36
A-8	Design Analysis Guideline No. 2, Aluminum	37
A-9	Design Analysis Guideline No. 3, Aluminum	38
A-10	Design Analysis Guideline No. 4, Aluminum	39
A-11	Design Analysis Guideline No. 5, Aluminum	40
A-12	Design Analysis Guideline No. 6, Aluminum	41
A-13	Design Analysis Guideline No. 1, Titanium	42
A-14	Design Analysis Guideline No. 2, Titanium	43
A-15	Design Analysis Guideline No. 3, Titanium	44
A-16	Design Analysis Guideline No. 4, Titanium	45
A-17	Design Analysis Guideline No. 5, Titanium	46
A-18	Sample Analytical Part-Cost Analysis for Two Different Corner Radii	49
A-19	Cost of Avoiding a 1-lb. Weight Increase	52

APPENDIX A
LIST OF TABLES

<u>Table</u>		<u>Page</u>
A-I	Aluminum Design Comparison Parts Data Summary	14
A-II	Cost Analysis Summary of 31 Aluminum F-111 Production Parts	21
A-III	Aluminum Production Cost Factors	23
A-IV	Cost Analysis of Aluminum Comparison Parts	24
A-V	Titanium Design Comparison Parts Data Summary	28
A-VI	Cost Analysis of Titanium NC Parts	31
A-VII	Production Cost Factors - Titanium	33
A-VIII	Cost Analysis of Titanium Comparison Parts	34

APPENDIX A

"COMPARISON PART" ANALYSES

The analytical and data basis for the generation of Design Guidelines is provided in this appendix. The guidelines developed are also presented.

1.0 GENERAL APPROACH TO ANALYSIS

The approach taken to illustrate the benefit of relaxing tolerances and surface finish requirements involved three basic steps:

- (1) create a small "unit" part representative of larger pocketed parts such that design features and machining procedures can be easily varied and analyzed,
- (2) use detailed cost data from NC machined parts to segregate and develop cost factors, and
- (3) apply these cost factors to the unit parts to determine the effect on costs of changes in design features and machining procedures.

A "unit" part was created to be representative of a large variety of pocketed aluminum parts. This, then, became a baseline designed with conventional features in terms of details and tolerances. A NC machining program was then generated and processed by a computer to give tape run time.

A number of typical alternate design features were then identified; and new parts, "design comparison parts," were designed, each differing from the baseline in only one feature. NC programs were also generated for each of these, and tape time was determined.

Each NC program was designed with cutter operations and feed rates completely realistic such that an actual comparison part could be machined if it was desired. This is described in Sections 3.2 and 4.2.

In order to be able to estimate cost for each of the aluminum comparison parts, 31 large F-111 NC machined aluminum bulkheads and spars were chosen; cost data for each part for the various basic factory functions was assembled from the GD/FWD

computerized cost data centers. This was analyzed in the manner described in Sections 3.3 and 3.4, and the resulting relationships were used to estimate the man-hour cost for each comparison part, described in Section 3.5.

To estimate cost for each of the titanium comparison parts, 13 large NC machined titanium (6Al-4V beta annealed) parts were chosen from the Advanced Metallic Air Vehicle Structures (AMAVS) program, Contract F33615-73-C-3001; cost data for each part for the various basic factory functions were assembled from the computerized cost data centers. This was analyzed in the manner described in Sections 4.3 and 4.4; and the resulting relationships were used to estimate the man-hour cost for each comparison part, described in Section 4.5.

Finally, the Guidelines of Section 5.0 were created, drawing from the data described. This consisted of summarizing and analyzing the cost and weight differences between the baseline and competing comparison parts or the differences between two other competing comparison parts. Each comparison led to a conclusion or Guideline.

2.0 MATRIX OF DESIGN COMPARISON PARTS

Small unit parts representative of large pocketed aluminum and titanium parts were designed to determine the benefit of relaxed tolerances (See Figure A-1), including changes in machining procedures. The parts were programmed for NC machining using the same procedures as if they were of larger parts. The smaller part is large enough to illustrate the changes and permitted a minimum programming task. Each NC program is complete and can be used to machine a part. The matrix of comparison parts examined is shown in Figures A-2 and A-3.

The baseline part (Figures A-4 and A-5) is typical of a part with pockets machined from one side. Machining procedures are typical for such a part. A rough and finish pass is made to web thickness, a rough cut is made in the corners and then the stiffener walls and corners get a finish cut. Two passes are then made on the outside perimeter of the part.

Each alternate part differs from the baseline by changing only one feature. The NC tape time then gives the change in time from that of the baseline for that one feature. Features examined include lands, flanged stiffeners, twisted contoured flanges, thin stiffeners, finish cuts, increased feed rates and relaxed tolerances.

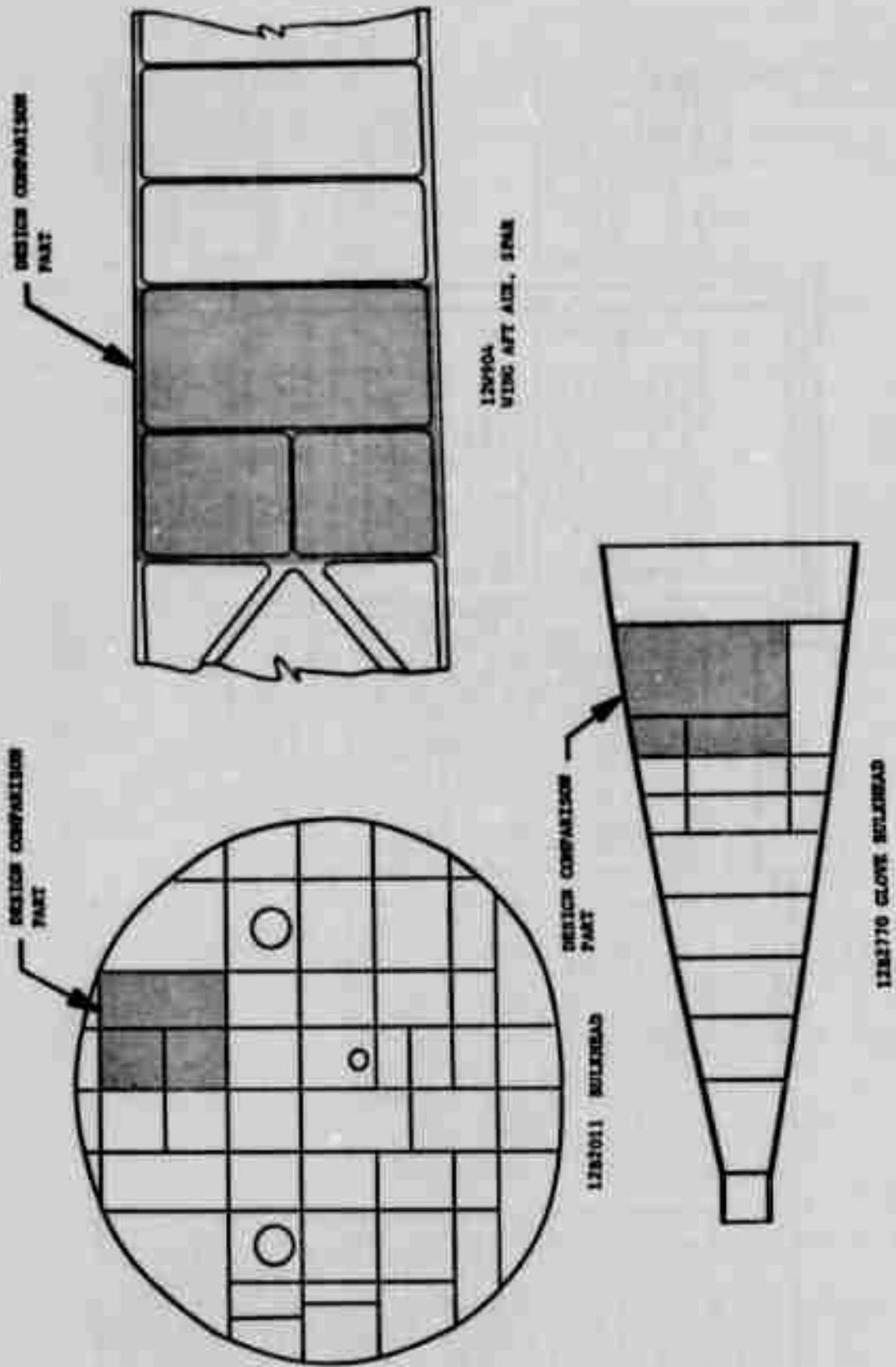

FIGURE A-1 DESIGN COMPARISON PART AS A PART OF PRODUCTION DESIGN

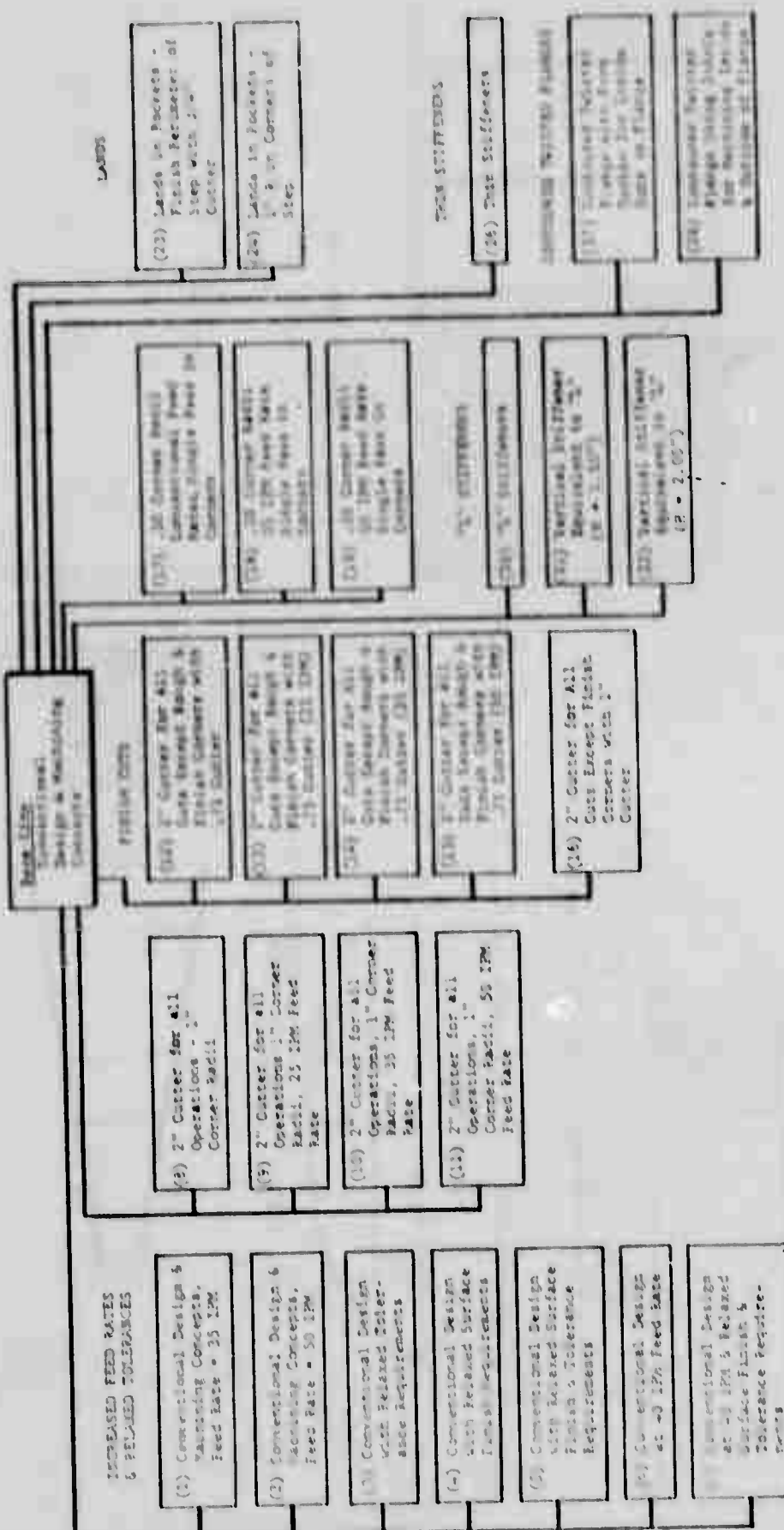

FIGURE A-2 PART II OF ALUMINUM DESIGN COMPANION PARTS

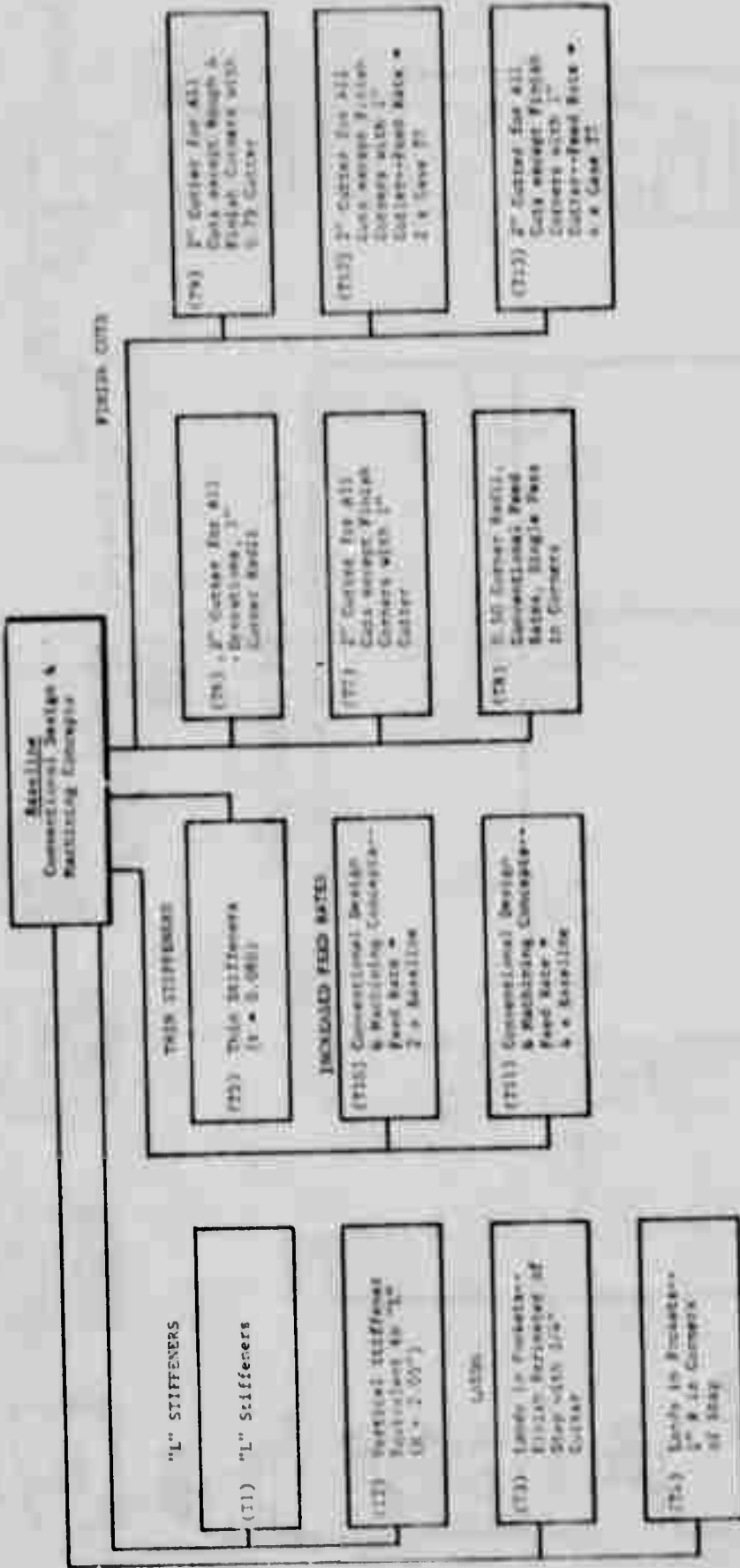

FIGURE A-3 MATRIX OF TITANIUM DESIGN COMPARISON PARTS

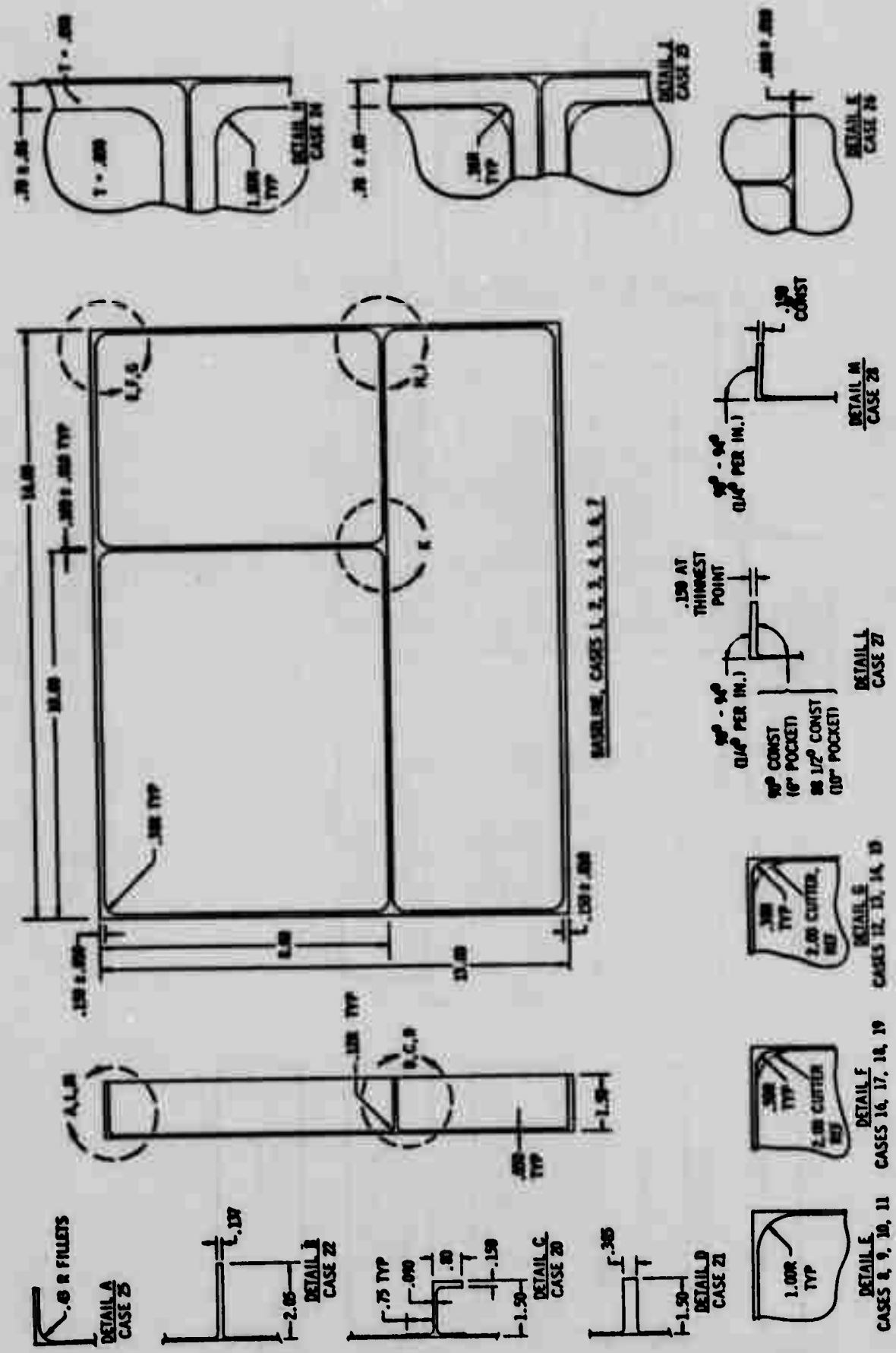

FIGURE A-4 ALUMINUM BASELINE PART DESIGN AND ALTERNATE DETAILS

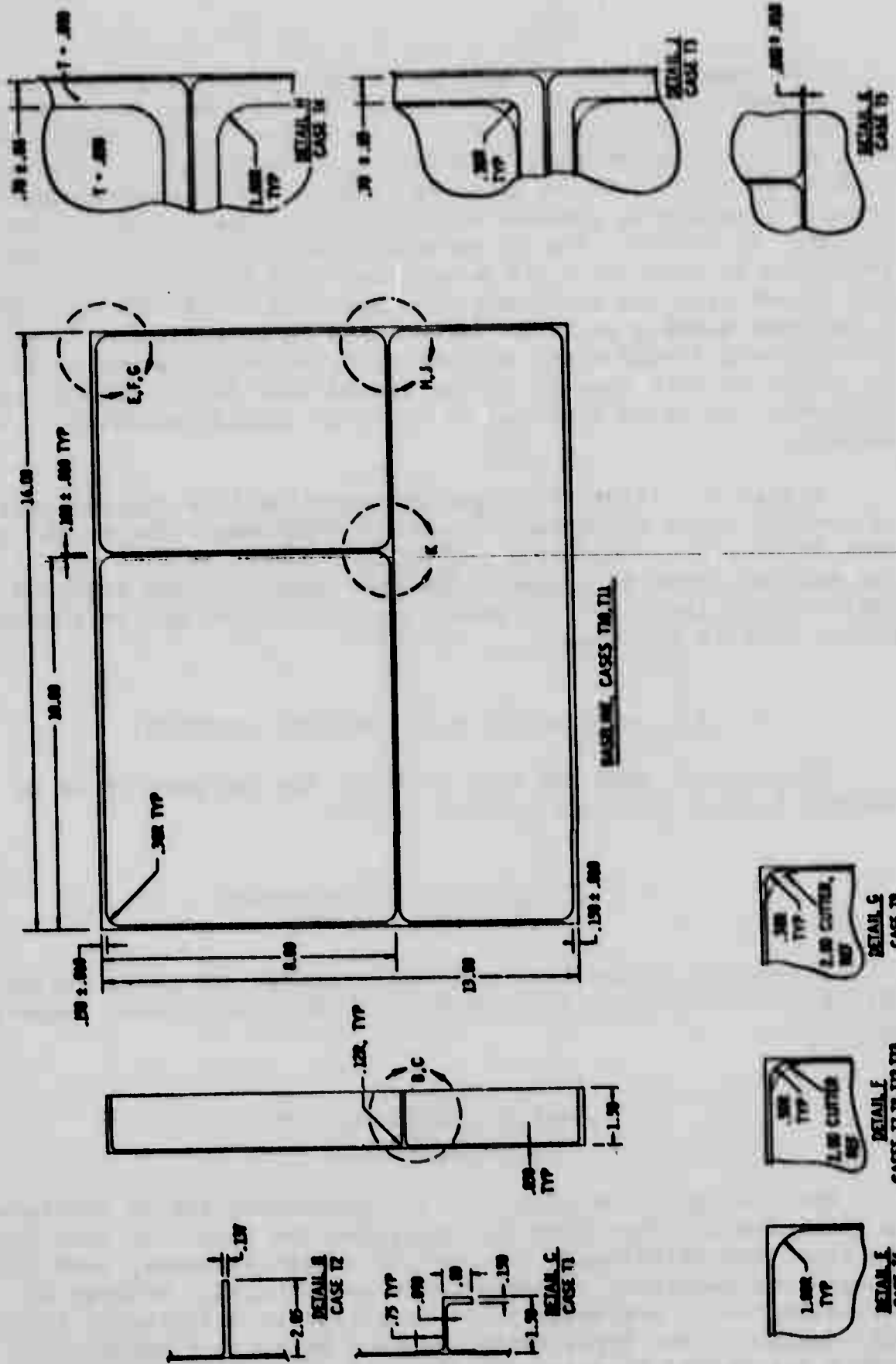

FIGURE A-5 TITANIUM BASELINE PART DESIGN AND ALTERNATE DETAILS

The baseline part with three pockets of varying size is typical of pocketed structure and has all of the features of the areas where 90% + of machining is done. Local load introduction areas were not included because these vary and could not be typified. Pockets were provided on one side only on the comparison parts because programming pockets on the second side is done in the same manner. In reality, the NC machine operator manually reduces the feed rate by overriding the programmed feed rate a little more on the second side due to having less material behind the web; however, a designer usually provides for pockets on both sides only when the required flange width or connecting structure requires it, so an option to omit pockets on the second side seldom exists. Consequently, no value appeared to exist to justify analysis of such options.

Figure A-1 illustrates how the baseline is a typical portion of several types of machined pocketed structure. The weight and cost figures presented will, of course, change to some extent for the various types of larger parts that exist but are believed sufficiently indicative to permit decisions that may be somewhat better than in the past.

3.0 ALUMINUM NC DATA AND COST ANALYSIS

Aluminum NC data and cost analysis for the guidelines in Section 5.1 are provided in this section.

3.1 Matrix of Aluminum Design Comparison Parts

Figure A-2 summarizes each of the comparison parts analyzed. Figure A-4 illustrates the geometrical features of each comparison part.

3.2 Design Comparison Parts-- Data Summary

Each design comparison part was programmed for NC machining to determine the tape time for machining the part. In this way the tape time differences for various design features, feed rate changes and machining concepts could be measured. Methods of estimating costs are usually not sensitive to differences in detail design of the types being examined here, so a better procedure was needed to determine the cost of the design features

being considered. Correlation of NC tape time and NC machine man-hours was then established as explained in the following paragraphs.

The NC programs were processed to give the time for each operation. Each operation was then examined to determine reasons for changes in total machine time. This data along with weights, cutter sizes and feed rates is summarized in Table A-I.

3.3 Cost Analysis Summary of 31 F-111 Production Parts

To establish the total cost of the cost comparison parts, cost data for 31 production parts were analyzed to establish cost factors for estimation purposes. These parts were bulk-heads, wing spars, and longerons, each having features similar to the cost comparison parts.

Manufacturing cost data is collected for each part by cost task center on a computerized system at GD/FWD. Each part in manufacturing has a computer card with a code number which identifies the part, work order and other data. This card is part of the "traveler" package that includes planning for the part. When an employee begins work on a part, he goes to a nearby computer terminal, inserts his employee identification badge, the computer card and a plastic card identifying the task center and indicates that he is starting the job. When he completes one job and starts another, he repeats the procedure closing out the first by starting the second job.

This data is transmitted from the computer terminal to the central data processing system where it is processed to produce data in the form shown in Figure A-6. The data shown is a monthly report which is placed on microfiche.

Data has been collected by task center since January 1972. Basically the report shows the average hours per task center for the number of parts indicated. Total cost data for 1965 and on is also shown. This data was used to develop the cost factors in Section 3.4.

The costs affected by relaxed tolerances are machining cost and hand finishing costs. The other costs such as material preparation, etc., are not affected directly by tolerance relaxations. Costs were placed in three categories: (1) NC machine hours,

TABLE A-1 ALUMINUM DESIGN COMPARISON PARTS DATA SUMMARY

Case No.	Description	Tolerance		Weight (Lbs.)	In ³ Left	In ³ Removed	Operation	Cutter Size	Feed Rate (In. per Min)		Total Time per Operation (Min.)
		Length	Thickness						Rough	Finish	
Base Line	Conventional Design & Machining Concepts	± 0.03	± 0.010	2.53	25.3	297.64	1. Rough & Finish Pockets, Leave 0.03 on Stiffener 2. Rough Corners, Finish Pocket 3. Rough & Finish Perimeter	2.00 x 0.12 R	25	25	27
									15	20	9
									25	20	8
1	Conventional Design & Machining Concepts. Feed Rate = 25 IPM	± 0.03	± 0.010	2.53	25.3	297.64	1. Rough & Finish Pockets, Leave 0.03 on Stiffener 2. Rough Corners, Finish Inside Perimeter 3. Rough & Finish Outside Perimeter	2.00 x 0.12 R	35	35	25
2	Conventional Design & Machining Concepts. Feed Rate = 50 IPM	± 0.03	± 0.010	2.53	25.3	297.64	1. Rough & Finish Pockets, Leave 0.03 on Stiffener 2. Rough Corners, Finish Inside Perimeter 3. Rough & Finish Outside Perimeter	2.00 x 0.12 R	15	50	5
3	Conventional Design with Relaxed Tolerance Requirements (+ 0.015/- 0.010 for stiffener and flanges)	± 0.03	± 0.010 + 0.015 - 0.010	2.54	25.4	297.54	1. Rough & Finish Pockets, Leave 0.03 on Stiffener 2. Rough Corners, Finish Pocket 3. Rough & Finish Perimeter	2.00 x 0.12 R	25	25	27
									15	20	9
									25	20	8
4	Conventional Design with Relaxed Surface Finish Requirements	± 0.03	± 0.010	2.57	25.7	297.25	1. Rough & Finish Pockets, Leave 0.03 on Stiffener 2. Rough Corners, Finish Pockets 3. Rough & Finish Perimeter	2.00 x 0.12 R	25	25	27
5	Conventional Design with Relaxed Surface Finish & Tolerance Requirements (+ 0.015/- 0.010 for stiffener and flanges)	± 0.03	± 0.010 + 0.015 - 0.010	2.59	25.8	297.17	1. Rough & Finish Pockets, Leave 0.03 on Stiffener 2. Rough Corners, Finish Pocket 3. Rough & Finish Perimeter	2.00 x 0.12 R	25	25	27
									15	20	9
									25	20	8
6	Conventional Design at 40 IPM	± 0.03	± 0.010	2.57	25.7	297.25	1. Rough & Finish Pockets, Leave 0.03 on Stiffener 2. Rough Corners, Finish Pocket 3. Rough & Finish Perimeter	2.00 x 0.12 R	40	40	26.4
									15	40	5.6
									40	40	5.6

TABLE A-1. (Continued)

Case No.	Description	Tolerance Length	Tolerance Thickness	Weight (Lb.)	In ³ Removed	Operation	Cutter Size	Feed Rate (ft. per Min.)	Time per Operator (Min.)	Total Tape Time (Min.)
7	Conventional Design at 40 IPM & related surface Finish & Tolerance Requirements.	± 0.03 ± 0.010	± 0.010 ± 0.010	2.57	25.7	1. Rough & Finish Pockets, Leave 0.03 on Edges 2. Rough Corners, Finish 3. Pocket & Finish Perimeter	2.00 x 0.12 R 0.75 x 0.12 R 2.00 x 0.01 R	40 15 40	24.4 3.6 5.6	33.6
8	2" Cutter for all Operations, 1" Corner Radii	± 0.03	± 0.010	2.83	28.3	1. Finish Pockets Net (No Special Finish Cut) 2. Finish Outside Perimeter, Single Pass	2.00 x 0.12 R 2.00 x 0.01 R	-- --	17 5	22
9	2" Cutter for all Operations, 1" Corner Radii, 25 IPM Feed Rate	± 0.03	± 0.010	2.83	28.3	1. Finish Pockets Net 2. Finish Outside Perimeter, One Pass	2.00 x 0.12 R 2.00 x 0.01 R	-- --	16 4	20
10	2" Cutter for all Operations, 1" Corner Radii, 35 IPM Feed Rate	± 0.03	± 0.010	2.83	28.3	1. Finish Pockets Net 2. Finish Outside Perimeter, One Pass	2.00 x 0.12 R 2.00 x 0.01 R	-- --	14 4	18
11	2" Cutter for all Operations, 1" Corner Radii, 50 IPM Feed Rate	± 0.03	± 0.010	2.83	28.3	1. Finish Pockets Net 2. Finish Outside Perimeter, One Pass	2.00 x 0.12 R 2.00 x 0.01 R	-- --	12 3	15
12	2" Cutter for all Cuts except Rough & Finish Corners with 0.75 Cutter (25 IPM)	± 0.03	± 0.010	2.53	25.3	1. Finish Pockets Net 2. Rough & Finish Corners Only 3. Finish Outside Perimeter	2.00 x 0.12 R 0.75 x 0.12 R 2.00 x 0.01 R	-- 15 --	17 5 5	27
13	2" Cutter for all Cuts except Rough & Finish Corners with 0.75 Cutter (35 IPM)	± 0.03	± 0.010	2.53	25.3	1. Finish Pockets Net 2. Rough & Finish Corners Only 3. Finish Outside Perimeter	2.00 x 0.12 R 0.75 x 0.12 R 2.00 x 0.01 R	-- 15 --	16 5 4	25
14	2" Cutter for all Cuts except Rough & Finish Corners with 0.75 Cutter (50 IPM)	± 0.03	± 0.010	2.53	25.3	1. Finish Pockets Net 2. Rough & Finish Corners Only 3. Finish Outside Perimeter	2.00 x 0.12 R 0.75 x 0.12 R 2.00 x 0.01 R	-- 15 --	14 5 4	23
15	2" Cutter for all Cuts except Rough & Finish Corners with 0.75 Cutter (50 IPM)	± 0.03	± 0.010	2.53	25.3	1. Finish Pockets Net 2. Rough & Finish Corners Only 3. Finish Outside Perimeter	2.00 x 0.12 R 0.75 x 0.12 R 2.00 x 0.01 R	-- 15 --	13 4 4	21

TABLE A-1 (Continued)

Case No.	Description	Tolerances		Weight (lbs.)	In ³ (left)	In ³ (right)	Operation	Cutter Size	Feed Rate (ft. per min.)	Tape Time per Operation (min.)	Total Tape Time (min.)
		Length	Thickness								
16	2" Cutter for all cuts except Fin-Cut Corners with 1/2" Cutter	± 0.03	± 0.010	2.57	23.7	297.25	1. Finish Pockets Not 2. Finish Corners Only, One Pass 3. Finish Outside Perimeter	2.00 x 0.12 # 1.00 x 0.12 #	-- 25	17 3	20
17	0.35 Corner Knoll, Corner- stiffed Feed Rate, Single Pass in Corners	± 0.03	± 0.010	2.57	23.7	297.25	1. Rough & Finish Pockets, Leave 0.03 on Stiffener 2. Finish Inside Perimeter, One Pass 3. Rough & Finish Outside Perimeter	2.00 x 0.12 # 1.00 x 0.12 # 2.00 x 0.01 #	25 -- 25	21 6 8	35
18	0.35 Corner Knoll, 35 IPW Feed Rate, Single Pass in Corners	± 0.03	± 0.010	2.57	23.7	297.25	1. Rough & Finish Pockets, Leave 0.03 on Stiffener 2. Finish Inside Perimeter, One Pass 3. Rough & Finish Outside Perimeter	2.00 x 0.12 # 1.00 x 0.12 # 2.00 x 0.01 #	50 -- 50	21 4 5	30
19	1" Stiffeners	± 0.03	± 0.010	3.06	30.4	399.35	1. Rough & Finish Pockets 2. Rough & Finish Inside Perimeter 3. Rough & Finish area under 1/2" Cutter 4. Rough & Finish Outside Perimeter	2.00 x 0.12 # 0.75 x 0.12 # 1/2" Cutter 2.00 x 0.01 #	25 15 15 25	21 10 6 8	45
21	Vertical Stiffener Equivalent 0.75" (H x 1.5)	± 0.03	± 0.010	3.51	35.1	462.88	1. Rough & Finish Pockets, Leave 0.03 on Stiffener 2. Rough Corners, Finish Inside Perimeter 3. Rough & Finish Outside Perimeter	2.00 x 0.12 # 0.75 x 0.12 # 2.00 x 0.01 #	25 15 25	21 8 8	37

TABLE A. 1. (Continued)

Case	Description	Stiffness (lb./in.)	Weight (lb.)	I_{xx} (in. ⁴)	I_{yy} (in. ⁴)	Detail	Case Size	Feed Rate (ft. per Min.)	Setup Time per Operation (min.)	Total Setup Time (min.)
22	Vertical Stiffener Equivalent to 1/2" (H x 2.00")	± 0.03 ± 0.010	2.91	29.7	279.8	1. Rough & Finish Inside & Outside in Three Passes, Leave 0.03 in Stiffener 2. Rough Corners, Finish Inside Perimeter 3. Rough & Finish Outside Perimeter	2.00 x 0.12 x	25	19	50
23	Lands in Profiles...Finish Tooling at top with 1/2" Cutter	± 0.03 ± 0.010	2.99	29.8	280.10	1. Rough to Land, Finish to Land Leaving 0.05 in Perimeter of Top & 0.03 in Stiffener 2. Finish Perimeter of Top & Rough Corners, Finish Inside Perimeter 3. Rough & Finish Outside Perimeter	2.00 x 0.12 x	25	23	53
24	Lands in Profiles...1/2" & 1/4" Corners at Top	± 0.03 ± 0.010	2.91	29.1	273.87	1. Rough to Land, Finish 40%, Leave 0.03 in Stiffener 2. Rough Corners, Finish Inside Perimeter 3. Rough & Finish Outside Perimeter	2.00 x 0.12 x 0.75 x 0.12 x 2.00 x 0.01 x	25 20 20	23 8 8	53
25	Give Flats Radial in Area of Lands (H x 0.45")	± 0.03 ± 0.010	2.95	29.3	272.50	1. Rough & Finish Inside, Leave 0.05 in Stiffener 2. Rough & Finish Inside Perimeter 3. Rough & Finish Outside Perimeter	2.00 x 0.12 x 3.00 x 0.45 x 2.00 x 0.01 x	25 20 20	23 11 8	53
26	Use Stiffeners	± 0.03 ± 0.010	2.39	23.9	239.05	1. Rough & Finish Inside, Leave 0.03 in Stiffener 2. Rough Corners, Finish Inside Perimeter, & Make One Free Pass 3. Rough & Finish Outside Perimeter	2.00 x 0.12 x 0.75 x 0.12 x 2.00 x 0.01 x	25 15 20	27 10 8	69

TABLE A-1 (Continued)

Case No.	Description	Tolerance		Weight (lbs.)	In ³ Left	In ³ Removed	Operation	Cutter Size	Feed Rate (In. per Min) Rough Finish	Tape Time per Operation (min.)	Total Tape Time (min.)
		Length	Thickness								
27	Contoured Twisted Flange with Form Cutters for Inside Cuts on Flange (1/20 per Inch Twist)	± 0.03	± 0.010	2.57	25.7	297.25	1. Rough & Finish Pockets, Leave 0.03 on Stiffener 2. Rough Corners, Finish Pockets Except for Flange 3. Finish Inside of Flange (2 Cutter Changes) 4. Finish Outside of Flange (3-Axis), Two Passes 5. Rough & Finish Balance of Perimeter	2.00 x 0.12 R 0.75 x 0.12 R Form Cutter 2.00 x 0.01 R 2.00 x 0.01 R	25 20 -- 20 20	27 8 2 2.2 5.8	45
28	Contoured Twisted Flange using 3-Axis for Machining Inside & Outside of Flange (1/20 per Inch Twist)	± 0.03	± 0.010	2.53	25.3	297.64	1. Rough & Finish Pockets, Leave 0.03 on Stiffener 2. Rough Corners, Finish Pockets except for Flange 3. Finish Inside of Flange (3-Axis) 4. Rough & Finish Flange (3-Axis) 5. Rough & Finish Balance of Perimeter	2.00 x 0.12 R 0.75 x 0.12 R 0.75 x 0.12 R 2.00 x 0.12 R 2.00 x 0.01 R	25 20 -- 20 20	27 8 2 2.2 5.8	45

FACTORY DEPT NO.		TASK CENTER		HOURS BY TASK CENTER SINCE JAN 1972		NUMBER OF PIECES SINCE JAN 1972	
032010							
PART NUMBER	S E T DEPT T/C	REV	DATE	TARGET MRS/PC	CUM 1972 MRS/PC	AVERAGE MRS/PC	PCS
1252700 10	0300 202	01	74 D	2.650	.321	33	
	0300 203	01	74 D	1.050	.127	33	
	0300 204	06	74 D	.000	.082	33	
	0300 205	01	74 D	.375	.485	33	
	0300 211	01	74 D	6.879	6.061	33	
	0300 212	01	74 D	3.397	3.233	33	
	0300 214	11	71 E	.000	.004	33	
	0300 220	12	71 E	.000	.212	33	
	0300 221	01	74 C	8.679	9.509	33	
	0300 232	08	74 E	.000	.164	33	
	0300 240	06	74 C	.000	.370	33	
	0300 244	01	74 D	16.164	17.945	33	
	0300 249	06	74 D	.000	.094	33	
	0300 250	01	74 C	.206	.867	33	
	0300 257	01	72 E	.000	.152	33	
	0310 133	01	72 E	.000	.503	33	
	0310 140	06	74 D	.000	.036	33	
	0310 141	06	74 D	.000	.003	33	
	0310 420	11	73 D	.317	.133	33	
	0310 551	06	74 D	.000	.030	33	
	0320 432	06	74 D	.000	.006	33	
	0330 702	09	74 E	1.000	1.006	33	
	0330 703	09	74 E	1.000	.064	33	
	0330 704	09	74 E	1.000	.091	33	
	0330 712	09	74 E	1.000	.006	33	
	0330 715	06	74 D	.000	.088	33	
	0330 720	09	74 E	1.000	.024	33	
	0330 722	09	74 E	1.000	.018	33	
	0390 422	01	74 D	.404	.506	33	
	0410 004	01	74 D	1.839	3.033	33	
	0410 124	01	74 C	.638	.600	33	
	0410 258	06	74 C	.000	.452	33	
	0740 747	01	74 C	.607	.524	33	
	2751 130	01	74 C	.425	.274	33	
	2751 133	01	74 C	.650	.482	33	
	2752 130	01	74 C	.577	2.476	33	
1242780 10	2752 139	01	74 C	.224	.181	33	
	2753 139	06	74 C	.000	.036	33	
	2753 140	06	74 C	.000	.082	33	
	2753 141	06	74 C	.000	.006	33	
	2754 148	01	74 C	.329	.173	33	
SUM 1965 ON ORDERS		PCS	HR/PC	CUM 1972			
MFG HOURS		33	46.2	91.105	46.191		
SUPPORT HOURS				3.210	4.214		
GRAND TOTAL				93.315	50.370		

FIGURE A-6 EXAMPLE OF GD/FWD MANUFACTURING COST DATA RECORD

adjusted to single spindle times, (2) hand finish hours, and (3) all other costs. Each of the three cost areas were analyzed to determine to which parameter the cost could best be related. Costs for each part were related to NC tape time, cubic inches removed and cubic inches left. This data is summarized in Table A-II.

3.4 Analysis of Production Cost Factors

The F-111 cost analysis summary (Table A-II) was used to establish the factors for estimating the cost of the comparison parts. Each of the cost parameter relationships was examined statistically to determine which was best for each of the three cost areas. The mean and the standard deviation was computed. The cost parameter relationship where the standard deviation was the smallest percentage of the mean was selected as the one to use for that cost area.

NC machine time (set up time plus run time) was best related to tape run time, as expected. Tape time multiplied by a factor is used at GD/FWD to schedule parts on NC machines thus demonstrating its power as a measure of cost. Included in the NC machine time is part set-up time which includes positioning the material on the machine, changing tapes and cutters, part removal, and other tasks done with the part on the machine, while metal is not being cut. This time is not affected by changes to NC machining. To determine the portion of time on the NC machine identified as "set-up time," twelve aluminum F-16 NC parts were surveyed. These parts are machined on 3, 4 & 5 axis machines and in many cases machined on two of them. Machine shop industrial engineering estimated the set-up time and actual run time for each part on each NC machine for a first article. Set-up time for these parts averaged 32% of the total time on the NC machine.

Hand finish time related best to cubic inches left (or weight) which was to be expected since hand finish time would be a function of part size or surface area. Once having established hand finish time for the baseline by this relationship, however, the differences created on the comparison parts were allowed to affect hand finish time only if there was a significant surface area change or if finish tolerances were relaxed. All other time was related to cubic inches removed, which is a measure of the work done on a part.

TABLE A-II COST ANALYSIS SUMMARY OF 31 ALUMINUM F-111 PRODUCTION PARTS

Part No.	In ³ Removed	In ³ Left	N/C Tape Time (Hrs.)	N/C Time (Hours)	N/C Hours per Tape Hour	N/C Hours per In ³ Removed	Hand Finish Time (Hrs.)	Hand Finish Time per Tape Hour	Hand Finish Time per In ³ Removed	Hand Finish Time per In ³ Left	All Other Mfg. Hours	All Other Mfg. Hours per In ³ Left	All Other Mfg. Hours Removed
1231535-27	6,132.7	669	6.26	43.72	7.75	6.00794	18.064	2.89	0.00391	0.02700	24.327	0.02636	0.00397
1231533-27	6,201.7	710	6.26	54.08	8.53	0.00887	19.951	3.13	0.00329	0.02811	48.725	0.06863	0.00800
1231533-29	6,231.7	710	6.59	59.44	9.02	0.00978	20.511	3.11	0.00336	0.02889	43.543	0.06133	0.00715
1231710-109	4,236	152	4.73	49.564	10.48	0.01170	15.272	3.23	0.00360	0.11569	23.323	0.17669	0.00550
1232103-17	4,384	239	5.12	60.412	11.20	0.01318	22.902	4.47	0.00500	0.09582	29.254	0.12244	0.00638
1232104-21	990.7	91	1.65	13.683	8.29	0.01351	8.432	5.11	0.00851	0.09255	13.863	0.15234	0.01399
1232104-22	990.7	91	1.65	11.319	6.96	0.01142	7.486	4.53	0.00755	0.08219	10.227	0.11235	0.01032
1232104-23	4,430	199.2	9.04	72.803	8.05	0.01644	18.251	2.02	0.00512	0.09162	33.604	0.19378	0.00571
1232104-25	3,079.1	215.0	10.18	111.013	10.90	0.03605	23.479	2.31	0.00762	0.10920	55.575	0.23948	0.01505
1232103-33	6,445.1	309.2	6.58	74.088	11.26	0.01149	33.681	5.12	0.00322	0.10892	29.687	0.05601	0.00461
1232103-34	4,710	343.8	9.56	84.511	9.84	0.01794	30.89	3.23	0.00455	0.08049	26.491	0.06494	0.00562
1232103-27	2,443	778.4	13.12	92.524	7.05	0.03978	32.76	12.50	0.01330	0.04208	29.053	0.03732	0.01179
1232103-19	566.2	106.6	3.27	10.01	3.06	0.01977	6.43	1.97	0.01270	0.06430	3.984	0.03954	0.00355
1232103-17	2,924.9	157.9	5.33	20.53	3.85	0.00678	5.77	1.08	0.00191	0.05566	10.642	0.06407	0.00469
1232103-15	2,267.3	95.8	3.00/3.40	16.39	5.45/4.62	0.00722	5.62	1.87/1.65	0.00258	0.03436	3.613	0.03254	0.00258
1232103-23	1,344	144	5.66	7.41	1.46	0.00530	7.10	1.40	0.00507	0.06396	3.613	0.04174	0.00249
1232103-11	8,965	923	19.47	100.13	5.14	0.00217	43.64	2.24	0.00487	0.04725	32.53	0.04149	0.00458
1232103-12	6,965	923	19.47	97.81	5.02	0.01091	49.31	2.53	0.00548	0.05142	41.07	0.04506	0.00227
1232103-25	1,090	137.3	2.56	15.05	5.87	6.01381	6.74	2.63	0.00618	0.04908	2.48	0.01806	0.00294
1232103-26	5,491	243.5	2.56	28.44	11.12	0.02509	5.80	2.26	0.00532	0.04224	3.20	0.02130	0.00262
1232103-19	5,491	243.5	9.61	80.05	8.33	0.01457	22.88	2.38	0.00416	0.07930	11.135	0.03860	0.00267
1232103-20	10,260	541.2	11.45	71.74	7.47	0.01506	22.35	2.32	0.00407	0.07746	11.37	0.03941	0.00267
1232103-34	10,260	541.2	11.45	70.31	6.14	0.00885	13.55	1.98	0.00132	0.02503	11.59	0.02141	0.00113
1232103-15	6,195	503	11.45	85.6	7.47	0.00834	19.34	1.98	0.00138	0.03573	12.00	0.03217	0.00116
1232103-16	6,195	503	11.45	73.66	6.43	0.01189	21.98	1.45	0.00343	0.04213	17.30	0.03266	0.00249
1232103-31	10,139	1079	15.44	75.91	5.94	0.01079	17.96	1.57	0.00290	0.03556	16.71	0.03309	0.00249
1232103-32	10,139	1079	15.44	55.08	4.92	0.00748	44.05	2.85	0.00434	0.04082	36.68	0.03399	0.00249
1232103-17	56.8	56.8	1.95	20.69	10.71	0.02706	4.79	2.45	0.00620	0.08433	4.54	0.07992	0.00568
1232103-18	772	772	1.95	13.06	9.26	0.02339	4.16	2.13	0.00539	0.07324	5.42	0.05952	0.00702

The F-111 costs were for an average of 51 units. Cost factors were then adjusted to give the first article cost on a 90% learning curve. The 90% learning curve is the policy of GD/FWD Industrial Engineering on NC parts of the type analyzed. Therefore, all costs in terms of man-hours for the cost comparison parts are first article costs. Table A-III summarizes the factors developed.

3.5 Cost Analysis of Comparison Parts

Using the cost factors developed in paragraph 3.4, the man-hours to manufacture the first article were computed for each comparison part. Set-up time for each part was established as a constant of 2.68 hours based on 32% of the NC machine time of 8.38 hours (11.435×0.733) for the baseline part. For the other comparison parts, NC machine run time was computed as 68% of $11.435 \text{ man-hrs} \times \text{tape hours}$. Hand finish time was divided into tape hour types of hand finishing that would be done to the comparison parts. This division was based on a survey of the amount and type of hand finishing done on parts similar to the comparison parts. The time was divided as follows:

Deburr	29%
Surface Finish	42%
Tolerance Control	29%

The total man-hours were expressed also in hours per pound and hours per cubic inch removed, for use in the Guideline development. Table A-IV summarizes the cost data for each comparison part.

4.0 TITANIUM NC DATA AND COST ANALYSIS

Titanium NC data and cost analysis for the guidelines in Section 5.2 are provided in this section.

4.1 Matrix of Titanium Design Comparison Parts

Figure A-3 summarizes each of the comparison parts analyzed. Figure A-5 illustrates the geometrical features of each comparison part.

TABLE A-III ALUMINUM PRODUCTION COST FACTORS

COST ITEM	AVERAGE FOR 51 PARTS			FIRST ARTICLE COST FACTOR
	MEAN	STANDARD DEVIATION	COEFFICIENT OF VARIATION	
<u>NC Machine Time</u> o per hour of tape o per cubic inch removed	7.33	2.58	35.1% *	11.435
	0.01382	0.00856	61.9%	--
<u>Hand Finish Time</u> o per hour of tape o per cubic inch removed o per cubic inch left	2.94	2.06	70.1%	--
	0.00512	0.00275	53.7%	--
	0.06301	0.02698	42.8% *	0.0983
<u>All Other Time</u> o per cubic inch left o per cubic inch removed	0.07337	0.05828	79.4%	--
	0.00566	0.00387	68.3% *	0.00883

NOTES:

1. * indicates cost factors selected to estimate costs for cost comparison parts.
2. The large standard deviations are typical of those encountered in machined parts cost data.
3. A 90% learning curve was used to determine the first article cost factor based on average costs for 51 articles (e.g., 7.33 x 1.56 = 11.435, where 1.56 is the conversion factor to determine the first article cost when the average cost for 51 articles is known).
4. Statistical data was derived from Table A-II.

TABLE A-IV COST ANALYSIS OF ALUMINUM COMPRESSION PARTS

Case No.	Description	Type Time	Weight (Lbs.)	Cubic Inches Removed	Cubic Inches Left	No. of Cutter Chgs.	S/C Machine Run Time (Hours)	Mach Finish Time (Hours)			All Other Costs (Hours)	Total MFB Hours	Man-Hrs Per Lot	Man-Hrs Per Job Per
								Debur	Surf. Finish	Tol.				
Base Line	Conventional Design & Machining Concepts	44 Min (0.733 Hr)	2.53	297.64	25.3	2	5.70	0.29	1.05	0.72	2.63	13.50	5.335	0.04535
1	Conventional Design & Machining Concepts. Feed Rate = 35 IPM	37 Min (0.617 Hr)	2.53	297.64	25.33	2	4.79	0.72	1.05	0.72	2.63	12.59	4.976	0.04230
2	Conventional Design & Machining Concepts. Feed Rate = 50 IPM	33 Min (0.55 Hr)	2.53	297.64	25.33	2	4.27	0.72	1.05	0.72	2.63	12.07	4.771	0.040635
3	Conventional Design with Relaxed Tolerance Requirements	44 Min (0.733 Hr)	2.54	297.54	25.4	2	5.70	0.72	1.05	0.45	2.63	13.23	5.206	0.04446
4	Conventional Design with Relaxed Surface Finish Requirements	44 Min (0.733 Hr)	2.53	297.64	25.3	2	5.70	0.72	0.10	0.72	2.63	12.55	4.960	0.04217
5	Conventional Design with Relaxed Surface Finish & Tolerance Requirements	44 Min (0.733 Hr)	2.58	297.17	25.8	2	5.70	0.72	0.10	0.14	2.61	11.95	4.426	0.04008
6	Conventional Design at 40 IPM	35.6 (0.593 Hr)	2.53	297.64	25.3	2	4.61	0.72	1.05	0.72	2.63	12.41	4.965	0.04264
7	Conventional Design at 40 IPM & Relaxed Surface Finish & Tolerance Requirements	35.6 (0.593 Hr)	2.70	295.97	27.0	2	4.61	0.72	0.11	0.14	2.61	10.87	4.026	0.03573
8	2" Cutter for All Operations, 1" Corner Radii	22 Min (0.367 Hrs)	2.57	294.44	28.5	1	2.85	0.72	1.05	0.72	2.60	10.62	3.726	0.03607
9	2" Cutter for All Operations, 1" Corner Radii, 25 IPM Feed Rate	20 Min (0.333 Hr)	2.85	294.44	28.5	1	2.55	0.72	1.05	0.72	2.60	10.56	3.635	0.03516
10	2" Cutter for All Operations, 1" Corner Radii, 35 IPM Feed Rate	18 Min (0.300 Hr)	2.85	294.44	28.5	1	2.33	0.72	1.05	0.72	2.60	10.12	3.55	0.03437
11	2" Cutter for All Operations, 1" Corner Radii, 50 IPM Feed Rate	16 Min (0.267 Hr)	2.85	294.44	28.5	1	2.07	0.72	1.05	0.72	2.60	9.64	3.453	0.03342
12	2" Cutter for All Cuts except Rough & Finish Corners with 0.75 Cutter (25 IPM)	27 Min (0.450 Hr)	2.53	297.64	25.3	2	3.50	0.72	1.05	0.72	2.63	11.30	4.466	0.05796
13	2" Cutter for All Cuts except Rough & Finish Corners with 0.75 Cutter (25 IPM)	25 Min (0.417 Hr)	2.53	297.64	25.3	2	3.24	0.72	1.05	0.72	2.63	11.04	4.364	0.03709

TABLE A-IV (Continued)

Case No.	Description	Tape Time	Weight (Lbs.)	Cubic Inches Removed	Cubic Inches Left	No. of Cutter Chgs.	N/C Machine Run Time (Hours)	Hand Finish Time (Hours)			All Other Costs (Hours)	Total Mfg. Hours	Man-Hrs Per In. Run		
								Deburr 0.29	Surf. Finish 0.42	Tot. 0.29					
14	2" Cutter for All Cuts except Rough & Finish Corners with 0.75 Cutter (35 IPM)	23 Min (0.383 Hr)	2.53	297.64	25.3	2	2.98	0.72	1.05	0.72	2.49	2.53	10.78	4.261	0.03422
15	2" Cutter for All Cuts except Rough & Finish Corners with 0.75 Cutter (50 IPM)	21 Min (0.350 Hr)	2.53	297.64	25.3	2	2.72	0.72	1.05	0.72	2.49	2.63	10.52	4.158	0.01397
16	2" Cutter for all Cuts except Finish Corners with 1" Cutter	25 Min (0.417 Hr)	2.57	297.25	25.7	2	3.24	0.72	1.05	0.72	2.49	2.62	11.03	4.292	0.03711
17	0.50 Corner Radii, Conventional Feed Rates, Single Pass in Corners	39 Min (0.65 Hr)	2.57	297.25	25.7	2	5.05	0.72	1.05	0.72	2.49	2.62	12.84	4.996	0.0622
18	0.50 Corner Radii, 35 IPM Feed Rate, Single Pass in Corners	35 Min (0.583 Hr)	2.57	297.25	25.7	2	4.53	0.72	1.05	0.72	2.49	2.62	12.32	4.794	0.06145
19	0.50 Corner Radii, 50 IPM Feed Rate, Single Pass in Corners	32 Min (0.533 Hr)	2.57	297.25	25.7	2	4.14	0.72	1.05	0.72	2.49	2.62	11.93	4.662	0.06011
20	"L" Stiffeners	47 Min (0.783 Hr)	3.06	292.38	30.5	3	6.09	0.76	1.11	0.76	2.63	2.58	13.95	4.567	0.06742
21	Vertical Stiffener Equivalent to "L" (H = 1.5)	43 Min (0.717 Hr)	3.51	287.86	35.1	2	5.57	0.72	1.05	0.72	2.49	2.54	13.28	3.783	0.04612
22	Vertical Stiffener Equivalent to "L" (H = 2.05")	56 Min (0.933 Hr)	2.97	279.9	29.7	2	7.25	0.75	1.08	0.75	2.58	2.47	14.98	5.044	0.05314
23	Lands in Pockets--Finish Perimeter of Step with 3/4" Cutter	44 Min (0.733 Hr)	2.88	294.16	28.8	2	5.70	0.72	1.05	0.72	2.49	2.60	13.47	4.677	0.04579
24	Lands in Pockets--1" R in Corners of Step	40 Min (0.667 Hr)	2.89	294.06	28.9	2	5.19	0.72	1.05	0.72	2.49	2.60	12.95	4.447	0.04463
25	Large Fillet Radii in Lieu of Lands (R = 0.43")	44 Min (0.733 Hr)	2.95	293.50	29.5	2	5.70	0.72	1.05	0.72	2.49	2.59	13.46	4.563	0.04584
26	Thin Stiffeners	49 Min (0.817 Hr)	2.35	299.05	23.9	2	6.35	0.72	1.05	0.72	2.49	2.64	14.16	5.923	0.06735

TABLE A-IV (Continued)

Case No.	Description	Tape Time	Weight (Lbs.)	Cubic Inches Removed	Cubic Inches Left	No. of Cutter Chg's	M/C Machine Run Time (Hours)	Hand Finish Time (Hours)			Total Mfg. Hours	Mfg. Hrs per Lb.	Man-Hrs per In. Lb.
								Deburr	Surf. Finish	Tol.			
27	Contoured Twisted Flange with Form Cutters for Inside Cuts on Flange (1/4" per Inch Twist)	45 Min (0.75 Hr)	2.57	297.25	25.7	4	5.83	0.29	1.05	0.72	2.49	5.300	0.04592
28	Contoured Twisted Flange using 5-Axis for Machining Inside & Outside of Flange (1/4" per Inch Twist)	45 Min (0.75 Hr)	2.53	297.64	25.3	3	5.83	0.29	1.05	0.72	2.49	5.387	0.04379

- NOTES:
- 2.65 hours set-up time is constant for each part.
 - NC machine run time is $68\% \times 11.435 \text{ hrs/tape hr} \times \text{tape hours}$. This is actual machine run time which excludes set-up time, cutter change time, etc. Cost factor was developed based on single spindle machine.
 - "Total mfg hours" is the sum of:
 - o 2.68 hours set-up time
 - o NC machine run time
 - o Hand finish total
 - o All other costs
 - Hand finish time is same as baseline part unless the comparison part relaxes finish requirements or there was a significant change in surface area.
 - All costs are for first article.
 - Example for calculating total part cost (baseline part):
 - a. NC machine run time = tape time (0.733 hr.) x cost factor (11.435) x 68%
 - b. Set-up time (constant value for all parts - includes cutter change, etc.)
 - c. Hand finish time = cubic inches left (25.3) x cost factor (0.0983)
 - o deburr = $297 \times 0.29 \times 2.49 = 0.72 \text{ hr.}$
 - o surface finish = $421 \times 0.42 \times 2.49 = 1.05 \text{ hr.}$
 - o dimension control = $297 \times 0.29 \times 2.69 = 0.72 \text{ hr.}$
 - d. All other time = cubic inches removed (297.64) x cost factor (0.00883)
 - = 2.63 hr.
 - = 13.50 hr.
- Total Part Time

4.2 Design Comparison Parts-- Data Summary

Each cost comparison part was programmed for NC machining to determine the tape time for machining the part. In this way the tape time differences for various design features, feed rate changes and machining concepts could be measured. Conventional methods of estimating costs are usually not sensitive to differences in detail design of the types being examined here, so a better procedure was needed to determine the cost of the design features being considered. Correlation of NC tape time and NC machine man-hours was then established as explained in the following paragraphs.

The NC programs were processed to give the time for each operation. Each operation was then examined to determine reasons for changes in total machine time. This data along with weights, cutter sizes and feed rates is summarized in Table A-V.

4.3 Cost Analysis Summary of 13 AMAVS Titanium Parts

To establish the total cost of the cost comparison parts, cost data for 13 AMAVS parts were analyzed to establish cost factors for estimation purposes. These parts were bulkheads, beams, sculptured plates, large pocketed fittings, each having features similar to the cost comparison parts. Data was collected from the GD/FWD computerized cost task center system described in Section 3.3. NC tape time and material removal data was collected for each part.

The costs affected by relaxed tolerances are machining cost and hand finishing costs. The other costs such as material preparation, etc., are not affected directly by tolerance relaxations. Costs were placed in three categories: (1) NC machine hours, (2) hand finish hours, and (3) all other costs. Each of the three cost areas were analyzed to determine to which parameter the cost could best be related. Costs for each part were related to NC tape time, cubic inches removed and cubic inches left. This data is summarized in Table A-VI.

TABLE A-1 TITANIUM DESIGN COMPARISON PARTS DATA SUMMARY

Case No.	Description	Tolerance		Wt. (Lbs)	In ³ Left	In ³ Removed	Operation	Cutter Size	Feed Rate (In. per Min)		RPM	Weight Removed per Op	Time per Oper	Total Time
		Length	Thickness						Rough	Finish				
Base-line	Conventional Design & Machining Concepts	± 0.03	± 0.010	4.053	25.33	297.64	1. Rough & Finish Pockets, Leave 0.03 on Stiffener	2.00 x 0.12 R	3.5	3.5	95	44.635	105	240
							2. Rough Corners, Finish Pocket, 1 free pass	0.75 x 0.12 R	1.5	2.5	250	1.232	94	
							3. Rough & Finish Perimeter	2.00 x 0.01 R	3.5	3.5	95	1.755	41	
T1	"L" Stiffeners			4.396	30.6	292.35	1. Rough & Finish Pockets, Leave .03 on stiffeners	2.00 x 0.12 R	3.5	3.5	95	40.81	90	281
							2. Rough & Finish Inside Perimeter, 1 free pass	0.75 x 0.12 R	1.2	2.5	250	1.20	127	
							3. Rough & Finish area under "L"	--	--	62	3.01	22		
							4. Rough & Finish Outside Perimeter	2.00 x 0.01 R	3.5	3.5	95	1.755	42	
T2	Vertical Stiffener Equivalent to "L" (H = 2.05")			5.516	34.48	306.94	1. Rough & Finish Pockets to Depth in 3 Passes, Leave 0.03 on Stiffener	2.00 x 0.12 R	3.5	3.5	95	61.01	156	291
							2. Rough Corners, Finish Inside Perimeter, 1 free pass	0.75 x 0.12 R	1.5	2.5	250	1.695	93	
							3. Rough & Finish Outside Perimeter	2.00 x 0.01 R	3.5	3.5	95	2.398	42	
T3	Lands in Pockets-- Finish Perimeter of Step with 3/4" Cutter	± 0.03	± 0.010	4.608	28.8	294.16	1. Rough to Land, Finish to Web Leaving 0.05 on Perimeter of Step & 0.03 on Stiffener	2.00 x 0.12 R	3.5	3.5	95	44.06	89	266
							2. Finish Perimeter of Step & Rough Corners, Finish Inside Perimeter, 1 free pass	0.75 x 0.12 R	1.5	2.5	250	1.24	136	
							3. Rough & Finish Outside Perimeter	2.00 x 0.12 R	3.5	3.5	95	1.755	41	

TABLE A-IV (Continued)

Case No.	Description	Inventory		WT (Lbs.)	In-3 Left	In-3 Right	Operation	Cutter Size	Feed Rate (ft./min.)	Weight removed per ft. of cut	Time per ft. of cut	
		Length (Inches)	Thickness (Inches)									
74	Leds in Pockets - 8 in Corners of Step	2.00	0.010	4,634	29.1	297.87	1. Rough to Land, Finish, Wh. Leave 0.03 on Stiffener 2. Rough Corners, Finish Inside Perimeters, 1 Free Pass 3. Rough & Finish Outside Perimeter	2.00 x 0.17 x 0.75 x 0.12 x 2.00 x 0.017	3-5 3-3 1-3 3-3 2-3 3-3	95 230 90	55.06 1.30 1.735	90 34 215 41
75	Thin Stiffeners (8 x 0.045)			3,826	23.81	309.05	1. Rough & Finish Pockets, Leave 0.03 on Stiffener 2. Rough Corners, Finish Inside Perimeter, & Make 1 Free Pass 3. Rough & Finish Outside Perimeter	2.00 x 0.12 x 0.75 x 0.12 x 2.00 x 0.017	3-3 3-3 2-3 3-3	90 230 90	44.860 1.235 1.735	104 133 280 67
76	2" Cutter for All Specs - Blump, 1" Corner Radii			4,940	28.5	294.44	1. Finish Pockets Set / No Special Finish-Cut 2. Finish Outside Perimeter, Single Pass	2.00 x 0.12 x 2.00 x 0.017	-- --	90 90	47.150 1.355	119 21
77	2" Cutter for All Cuts except Finish Corners with 1" Cutter			4,115	25.77	297.25	1. Finish Pockets Set 2. Finish Corners Only, 1 Free Pass 3. Finish Outside Perimeter	2.00 x 0.12 x 2.00 x 0.017	-- --	90 90	45.250 1.448	58 25
78	0.50 Corner Radii, Conventional Feed Rates, Single Pass in Corners			4,335	25.72	297.25	1. Rough & Finish Pockets, Leave 0.03 on Stiffener 2. Finish Inside Perimeter, 1 Pass, 1 Free Pass 3. Rough & Finish Outside Perimeter	2.00 x 0.12 x 2.00 x 0.017	3-3 3-3 3-3	90 90 90	44.835 1.408 1.735	107 74 61
79	2" Cutter for All Cuts except Rough & Finish Corners with 0.75" Cutter			4,053	25.33	297.84	1. Finish Pockets Set 2. Rough & Finish Corners Only 3. Finish Outside Perimeter	2.00 x 0.12 x 0.75 x 0.12 x 2.00 x 0.017	-- 1-3 --	90 230 90	45.354 1.511 1.735	54 55 22
710	Conventional Design & Machining Concept - Feed Rate = 2 x Baseline	2.00	0.010	4,350	25.33	297.84						

TABLE A-V (Continued)

Case No.	Description	Tolerance		Wt (Lbs)	In ³ Left	In ³ Removed	Operation	Cutter Size	Feed Rate (In. per Min)		Weight Removed per Op	Time per Oper	Total Time
		Length	Thickness						Rough	Finish			
T11	Conventional Design & Machining Concepts--Feed Rate = 4 x Baseline	± 0.03	± 0.010	4.053	25.33	297.64	- - - - - Same as T7	-	14.0	14.0	44.635	28	65
T12	2" Cutter for All Cuts except Finish Corners with 1" Cutter-- Feed Rate = 2 x Case T7	↑	↑	4.115	25.72	297.25	- - - - - Same as T7	-	--	7.0	44.635	30	51
T13	2" Cutter for All Cuts except Finish Corners with 1" Cutter-- Feed Rate = 4 x Case T7	± 0.03	± 0.010	4.115	25.72	297.25	- - - - - Same as T7	-	--	14.0	44.635	16	28
									--	12.0	1.232	5	7
									--	14.0	1.755	7	

TABLE A-VI COST ANALYSIS OF TITANIUM MC PARTS

Part No.	In ³ Removed	In ³ Left	Surface Area (In ²)	MC [*] Tape Time (Hrs)	MC Machine Time (Hours)	MC Hours per Tape Hour	MC Hours per In ³ Removed	Hand Finish Time (Hrs)	Hand Finish Time per In ² of Surf Area	Hand Finish Time per In ³ Left	Hand Finish Time per Tape Hour	All Other Mfg Hours	All Other Mfg Hours per In ³ Removed	All Other Mfg Hours per In ³ Left
X7224031-7	500.3	724.2	3509	10.01	45.80	4.58	0.09154	27.80	0.00792	0.03839	2.78	2.30	0.00460	0.00318
X7224031-8	500.3	724.2	3509	10.01	47.80	4.78	0.09354	18.10	0.00316	0.02499	1.81	3.80	0.00760	0.00525
X7274061-7	2361.4	1573.1	16003	43.51	223.40	5.13	0.09460	66.90	0.00418	0.04253	1.54	48.80	0.02067	0.03102
X7224083-8	506.7	611.5	4452	10.81	66.10	6.11	0.13045	12.10	0.00272	0.02388	1.12	12.60	0.02487	0.02060
X7224172-7	779.1	503.9	5205	15.45	75.50	4.89	0.09691	11.40	0.00219	0.02262	0.74	12.60	0.01540	0.02381
X7224172-8	779.1	503.9	5205	15.45	76.10	4.93	0.09768	12.60	0.00231	0.02381	0.78	1.80	0.00231	0.00357
X7224173-7	2024.0	804.8	8901	30.77	174.70	5.68	0.08631	20.50	0.00230	0.02547	0.67	2.00	0.00099	0.00249
X72223901-9	4070.4	474.2	1626	44.87	219.80	4.90	0.05400	18.80	0.01156	0.03965	0.42	147.90	0.03633	0.31189
X72223901-10	4070.4	474.2	1626	44.87	171.95	3.93	0.04274	28.60	0.01759	0.06031	0.63	78.30	0.01924	0.16512
X72223930-7	3244.9	440.6	1075	26.27	216.40	8.24	0.06669	25.80	0.02400	0.05856	0.98	139.50	0.04299	0.31661
X72223930-5	3244.9	440.6	1075	26.27	184.40	7.02	0.05683	54.50	0.05069	0.12369	2.07	179.40	0.05529	0.40717
X72223931-7	2892.8	311.2	1053	13.80	73.40	5.32	0.02537	10.40	0.00988	0.03342	0.75	172.50	0.05963	0.55431
X72223931-8	2892.8	311.2	1053	13.80	57.00	4.13	0.01970	27.30	0.02592	0.08772	1.98	182.60	0.06312	0.58676

* NC tapes for these parts were programmed at feed rates as much as 10 times higher than the feed rate normally used to machine the part. This was done so that the tapes could be proofed as quickly as possible at the higher feed rates. NC tapes for aluminum are programmed at feed rates generally less than 2 times the feed rates used to machine the parts.

Because the "design comparison" parts (Table A-V) were programmed at lower feed rates than these were, the MC tape times for these parts were adjusted for lower feed rates. This permits the cost analysis to correctly reflect the proportion of cost for MC machining. This also permits use of the same procedures on estimating the cost of titanium "design comparison" parts as was used for the aluminum comparison parts.

4.4 Analysis of Production Cost Factors

The cost data summary (Table A-VI) was used to establish the factors for estimating the cost of the comparison parts. Each of the cost parameter relationships was examined statistically to determine which was best for each of the three cost areas. The mean and the standard deviation was computed. The cost parameter relationship where the standard deviation was the smallest percentage of the mean was selected as the one to use for that cost area. This data is summarized in Table A-VII.

NC machine time was best related to tape run time as expected. Tape time multiplied by a factor is used at GD/FWD to schedule parts on NC machines thus demonstrating its power as a measure of cost. Hand finish time related best to cubic inches left (or weight) which was to be expected since hand finish time would be a function of part size or surface area. Once having established hand finish time for the baseline by this relationship, however, the differences created on the comparison parts were allowed to affect hand finish time only if there was a significant surface area change or if finish tolerances were relaxed. All other time was related to cubic inches removed, which is a measure of the work done on a part.

4.5 Cost Analysis of Comparison Parts

Using the cost factors developed in paragraph 4.4, the man-hours to manufacture the article were computed for each comparison part.

Set-up time for the titanium parts is assumed to be the same number of hours as that for aluminum parts. For the baseline titanium part, NC machine time is 21.4 hours (4.0 tape hours x 5.35 man hours per hour of tape) of which 2.68 hours is set-up time, leaving 18.72 hours of NC machine run time. The NC machine run time for the baseline part is 87.5% $(18.72/21.4)$ (100%) of the total time on the machine. NC machine run time for the comparison parts is then computed at $.875 \times 5.35$ hours per tape hour x tape hours. A constant 2.68 hours per part is used for set-up time.

The total man-hours were expressed also in hours per pound and hours per cubic inch removed for use in the Design Analysis Guidelines. Table A-VIII summarizes the cost data for each comparison part.

TABLE A-VII PRODUCTION COST FACTORS--TITANIUM (3)

Cost Item	Mean	Standard Deviation	Coefficient of Variation
<u>NC Machine Time</u>			
o per hour of tape	5.35	1.20	22.4%*
o per in ³ removed	0.06675	0.03758	56.3%
<u>Hand Finish Time</u>			
o per hour of tape	1.25	0.72	57.6%
o per in ³ removed	0.01797	0.01484	82.6%
o per in ³ left	0.04654	0.02999	64.4%*
o per in ² of surface area	0.01280	0.01401	109.4%
<u>All Other Time</u>			
o per in ³ left	0.18706	0.22159	118.5%
o per in ³ removed	0.02715	0.02220	81.8%*

NOTES:

1. * indicates cost factors selected to estimate cost of cost comparison parts.
2. Cost factors listed are first article cost factors.
3. Statistical data was derived from Table A-VI.

TABLE A-VIII COST ANALYSIS OF TITANIUM COMPARISON PARTS

Case No.	Description	Tape Time (Hours)	Weight (Lbs.)	Cubic Inches Removed	Cubic Inches Left	No. of Cutter Chg's	N/C Machine Run Time (Hours)	Hand Finish Time (Hours)	All Other Costs (Hours)	Total Mfg. Hours	Man-Hrs per Lb.	Man-Hrs per In. Rem
Baseline	Conventional Design & Machining Concepts	4.00	4.053	297.64	25.33	2	18.72	1.17	8.08	30.65	7.562	0.10298
T1	"L" Stiffeners	4.68	4.896	292.35	30.60	3	21.91	1.42	7.93	33.94	6.932	0.11609
T2	Vertical Stiffener Equivalent to "L" (H = 2.05)	4.85	5.516	306.94	34.48	2	22.71	1.60	8.33	35.32	6.403	0.11507
T3	Lands in Pockets--Finish Perimeter of Step with 3/4" Cutter	4.35	4.608	294.16	28.80	2	20.36	1.34	7.99	32.37	7.025	0.11004
T4	Lands in Pockets--1" R in Corners of Step	3.75	4.656	293.87	29.10	2	17.55	1.35	7.98	29.56	6.349	0.10059
T5	Thin Stiffeners (t = 0.080)	4.68	3.826	299.05	23.91	2	21.91	1.11	8.12	33.82	8.840	0.11309
T6	2" Cutter for All Operations, 1" Corner Radii	1.33	4.560	294.44	28.50	1	6.22	1.33	7.99	18.22	3.996	0.06188
T7	2" Cutter for All Cuts Except Finish Corners with 1" Cutter	1.60	4.115	297.25	25.72	2	7.49	1.20	8.07	19.44	4.724	0.06540
T8	0.50" Corner Radii, Conventional Feed Rates, Single Pass in Corners	3.67	4.115	297.25	25.72	2	14.80	1.20	8.07	26.75	6.501	0.08999
T9	2" Cutter for all Cuts except Rough & Finish Corners with 0.75" Cutter	1.93	4.053	297.64	25.33	2	9.04	1.18	8.08	20.98	5.176	0.07049
T10	Conventional Design & Machining Concepts--Feed Rate = 2 x Baseline	2.07	4.053	297.64	25.33	2	9.67	1.18	8.08	21.61	5.332	0.07260
T11	Conventional Design & Machining Concepts--Feed Rate = 4 x Baseline	1.08	4.053	297.64	25.33	2	5.06	1.18	8.08	17.00	4.194	0.05712
T12	2" Cutter for All Cuts Except Finish Corners with 1" Cutter--Feed Rate = 2 x Case T7	0.85	4.115	297.25	25.72	2	3.98	1.20	8.07	15.93	3.871	0.05359
T13	2" Cutter for All Cuts Except Finish Corners with 1" Cutter--Feed Rate = 4 x Case T7	0.47	4.115	297.25	25.72	2	2.19	1.20	8.07	14.14	3.436	0.04757

NOTES:

- 2.68 hours set-up time is constant for each part.
- NC machine run time is 87.52 x 5.35 hours/tape hour x tape hours. This is actual machine run time which excludes set-up time, cutter change time, etc.
- "Total Mfg. Hours" is the sum of:
 - o 2.68 hours set-up time
 - o "NC machine run time"
 - o "Hand finish time"
 - o "All other costs"
- All costs are for first article.

5.0 GUIDELINES DEVELOPED

Guidelines were developed for both aluminum and titanium parts to exploit design features and the relaxation of tolerances and surface finish as demonstrated by the cost data analysis presented earlier.

5.1 Aluminum Guidelines

Design Guidelines for aluminum parts are presented in Figures A-7 thru A-12. Guideline No. 5 (Figure A-11) demonstrates the cost reduction and associated weight increase for machining the design comparison part with larger corner radii (1/2" vs. conventional 3/8"). The cost required to remove the additional weight associated with the larger radii will vary depending on the number of corners, the depth of cut, and the number of parts to be produced. In order for this guideline to be useful to the designer, an in-depth study of the factors involved and development of the analytical relationships are required to determine the cost difference for any application. This study is presented in section 5.3.

5.2 Titanium Guidelines

Design Guidelines for titanium parts are presented in Figures A-13 thru A-17. Guideline No. 5 (Figure A-17) addresses the advantage of increasing the corner radii of titanium parts. The cost and weight factors presented, however, are applicable only to the design comparison part. The study presented in Section 5.3 is for aluminum, but substitution of cost ratio, cutter feed rates and material density applicable to titanium will permit the determination of the cost difference for any application.

5.3 Cost Analysis for Machining Two Different Corner Radii in Aluminum

In an effort to make Guideline No. 5 more easily applied to any pocketed part, the following analysis and resulting nomograph is offered.

5.3.1 Introduction

A designer of large machined aircraft parts must make a number of trade-off decisions between cost and weight in detail

DESIGN ANALYSIS GUIDELINE

NO. 1

SUBJECT: FLANGED VS. VERTICAL STIFFENERS

MATERIAL: ALUMINUM

TYPE OF PART: LARGE MULTIPOCKET BULKHEAD OR SPAR

MACHINING PROCESS: END MILLING

GUIDELINE: A vertical stiffener up to a maximum height equal to the plate thickness should be used before considering a flanged stiffener. An "L" shaped stiffener will cost 3-4% more, and a "T" shaped stiffener will cost 9-11% more than a vertical stiffener in plates of equal thickness. Only when more stiffness is needed than the vertical stiffener can provide, should a flange stiffener be used.

ILLUSTRATION:

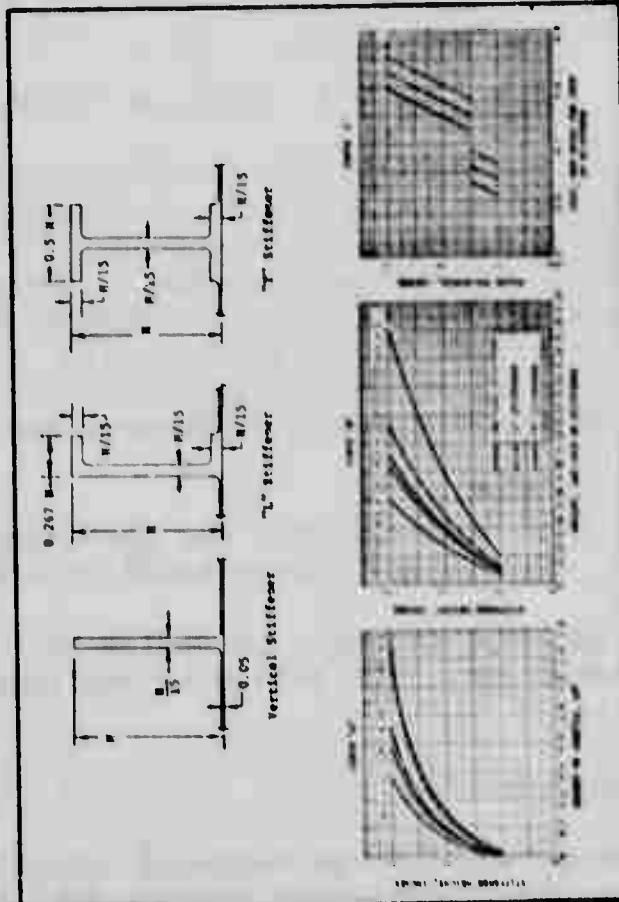

DISCUSSION: (cont'd)
4. Knowing weight and costs of the two stiffeners and program weight/cost guideline, the appropriate stiffener can be selected.

SUPPORTING DATA:

COST ANALYSIS OF COMPARISON PARTS

NC Tape	Case #	Case #	Case #	Δ Cost
Operation (Minimal of Cost Item)	20	B		
1	23	27		+ 4
2	10	9		- 1
3	6	--		- 5
4	8	8		0
	47	44		- 3
Man-Hours	13.98	13.59		- 0.48

Case	Cost	Cost	Cost
	Material	Incl	/Inch
#20 (1.5" L")	13.98	15.69	0.65375
Baseline (1.5" Vert)	13.50	15.21	0.63375
#22 (2.05" Vert)	14.98	17.32	0.72167
1.5" T	14.82	16.53	0.68875

* Cost, in man-hours

Mat'l Cost: 1.14 M-Hrs/Inch of Thickness

DISCUSSION: When the plate thickness exceeds approximately 1.5", an extra pass of the 2.0" D roughing cutter is required and results in a step in the cost curve (Curve "C"). The flanged stiffeners cost more because the material under the flange of the stiffener is removed with an extra operation using a file-cutter at a less efficient material removal rate than when the equivalent material is removed for a vertical stiffener.

Curves "A," "B," and "C" show moment of inertia, weight and cost for the stiffener shapes shown in the illustration. Feed rates were constant for all plate thicknesses. The proportions suggested are considered near optimum for structural efficiency. Vertical stiffeners with $H/t \geq 15$ are more difficult to machine so this upper limit was set. Curves are shown for vertical stiffeners of $H/t = 10$ and 5 also. Material cost, converted to man-hours, is included in the cost curve.

The following steps should be followed when using the curves:

1. Knowing "t" required, enter curve "A" and select (a) the tallest vertical stiffener and (b) the tallest "L" or "T" stiffener to meet the "t" requirement.
2. Read weights from Curve "B"
3. Read Cost from Curve "C"

FIGURE A-7 DESIGN ANALYSIS GUIDELINE NO. 1, ALUMINUM

DESIGN ANALYSIS GUIDELINE

NO. 2

TYPE OF PART: LARGE MULTIPOCKET BULKHEAD OR SPAR

SUBJECT: LANDS VS. NO LANDS ON POCKET WEBS

MATERIAL: ALUMINUM

MACHINING PROCESS: END MILLING

GUIDELINE: Edging a pocket with a land is roughly cost equivalent to a web without a land in aluminum. Design should therefore be based on weight and strength rather than cost. If web loads permit, 10-15% weight can be saved by use of a land, at no cost.

ILLUSTRATION:

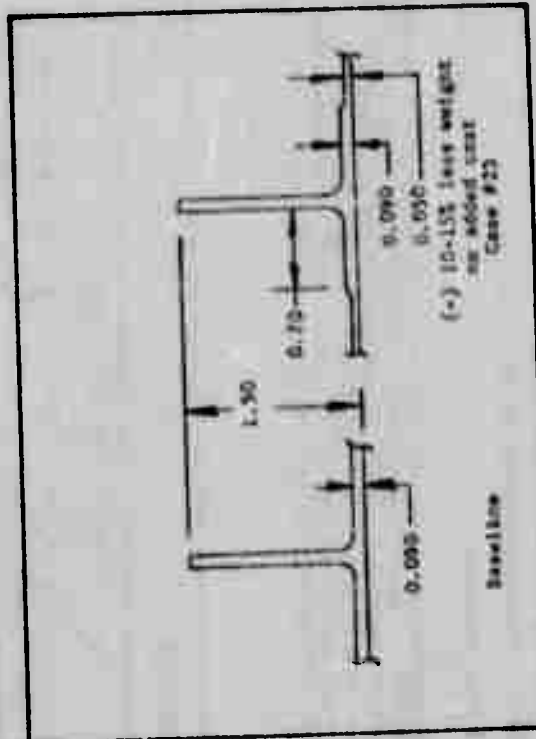

SUPPORTING DATA:

COST ANALYSIS OF COMPARISON PARTS

NC Tape Operation (Minute) or Cost Item	Case #8*	Case #23	ΔCost
#1 (See Table A-I for description)	27	23	-4
2	9	13	+4
3	8	8	0
	44	44	0
Total Cost, Manhours	13.50	13.47	-0.03
Weight of Comparison Part, Lbs.	3.325	2.88	-0.445
Average Manhours per Lb. Removed	0.4661	0.4579	-0.0082
% Change in Total Cost			-0.22%
% Change in Weight of Part			-13.38%

* Baseline in this case is assumed to have a web of 0.090" instead of 0.050" in order to illustrate the designer's options in a typical case.

DISCUSSION: For the feedrates used in rough/finish machining aluminum, the added cost of finish machining the land is roughly compensated by the reduced cost of machining the smaller area of 0.050" web. Consequently, when web loads permit, the "land" design approach can save 10-15% of the part weight compared to using no land, when edge thickness is critical.

Cost reduction can also be achieved. See Guideline #3.

REFERENCES: Tables A-I and A-IV

FIGURE A-8 DESIGN ANALYSIS GUIDELINE NO. 2, ALUMINUM

DESIGN ANALYSIS GUIDELINE

NO. 3

TYPE OF PART: LARGE MULTIPOCKET BULKHEAD OR SPAR

MACHINING PROCESS: END-MILLING

SUBJECT: RELAXED TOLERANCE AND RADII ON "LANDS"

MATERIAL: ALUMINUM

GUIDELINE: "Lands" are provided to reinforce the edge of a 0.640-0.050 web. A designer can save 3-5% of the part cost by permitting a 1" land corner radius and a ± 0.06 tolerance on land width rather than the 0.375" R and ± 0.03 " usually required. Cost of avoiding the small weight increase is extremely high.

ILLUSTRATION:

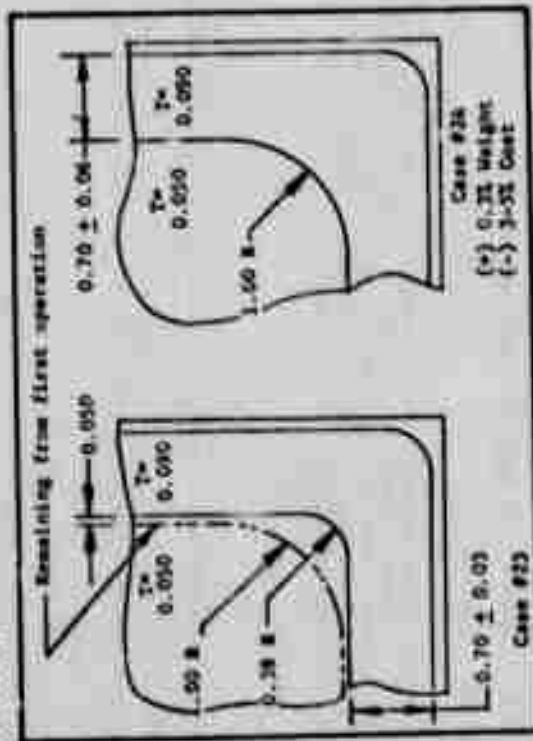

SUPPORTING DATA:

COST ANALYSIS OF COMPARISON PARTS

NC Tape	Operation	Minutes of Cost Item	Case #23	Case #24	Δ Cost
1	(See Table A-I for description)		23	23	0
2			13	9	-4
3			8	8	-0
			44	40	-4

Total Cost, Manhours 13.47 12.95 - 0.52
 Weight of Comparison Part, Lbs. 2.88 2.89 + 0.01
 Average Manhours per Lb. Removed 0.4579 0.4404
 % Change in Total Cost - 3.86%
 % Change in Weight of Part + 0.3%

Cost Rate of Avoiding Added Weight, M-Hrs/Lb = 0.52/0.01 = 52.0

DISCUSSION: A "land" is produced by rough machining to land depth over the area of a pocket, then machined typically 0.04" deeper to web depth leaving the land around the edges. The first operation usually leaves 0.05" extra on the land width and a 1" radius in the pocket corner of the land. A finish operation with a 3/4" D cutter trims this material away.

By not performing the trim operation, 3-5% of the cost is saved at a weight penalty of 0.3% for the part. The designer must then design with a 1" corner land radius and a more generous tolerance on the land width, i.e., ± 0.06 .

The cost of removing the 0.3% added weight is at a rate of 52 man-hours per pound, many times the average rate for the part.

REFERENCES: Tables A-I and A-IV

FIGURE A-9 DESIGN ANALYSIS GUIDELINE NO. 3, ALUMINUM

DESIGN ANALYSIS GUIDELINE

NO. 4

TYPE OF PART: LARGE MULTIPOCKET BULKHEAD ON SPAR

SUBJECT: EXCESSIVE WEIGHT/THICKNESS RATIO ON STIFFENER

MACHINING PROCESS: END-MILLING

MATERIAL: ALUMINUM

GUIDELINE: Designing to save weight by use of stiffer heights/thickness ratio above 15 increases cost 4-6% due to additional required finish passes by the cutter. Weight saved, however, is 5-6%. The cost rate for removing the weight saved is not higher than that for a typical finish cut.

ILLUSTRATION:

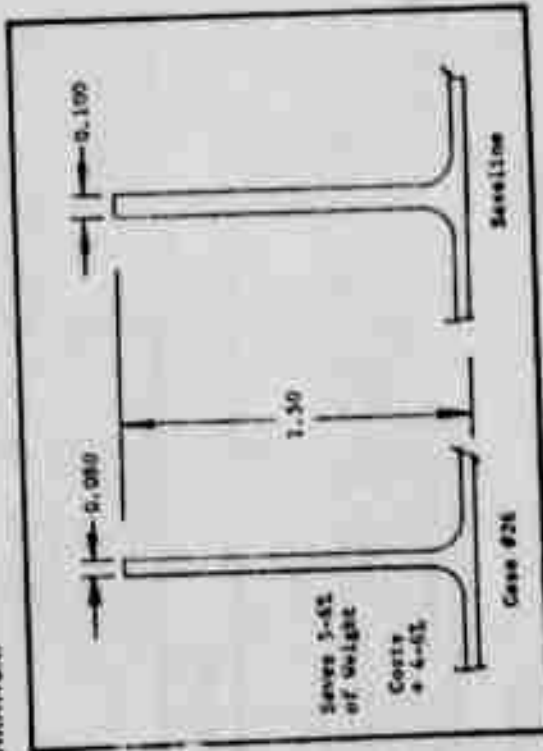

SUPPORTING DATA:

COST ANALYSIS OF COMPARISON PARTS

NC Tap	Case	Case	Case
Operation (Minutes) of Cost Item	Rate	Rate	Rate
#1 M&F pockets, 14 .07" on stiff 2" Ø 25 12M	27	27	27
#2 H corners, 7 pockets, Add 1 pass on .080 stiff. (Case 26) - 15" Ø 15-20 12M	3	14	+ 3
#3 M&F outside parts, 2" Ø 20-25 12M	22	49	+ 3
Total Cost, Machine	12.30	14.16	+ 0.66
Weight of Comparison Part, lbs.	2.33	2.39	- 0.14
Average Machine per Lb. Removed	0.4535	0.6735	
Change in Total Cost			+ 4.89%
Change in Weight of Part			- 5.3%
Cost Rate of Removing Weight Saved, M-Hrs/Lb = 0.66/0.14 = 4.7			

DISCUSSION: The additional cost required to machine a 1.5" x 0.080" stiffener rather than one with the practical minimum of 1.5" x 0.100" is 4-6% due to the need for additional finish cuts (Op. #2). Cost would increase further if stiffener were taller due to increased plate thickness (see Guideline #1). Also, probability of damage by cutter increases as height/thickness increases due to part flexibility. Weight saved, however, is relatively significant, 5-6%. Also, the cost rate of removing the weight saved, 5 m-hrs/lb, is not higher than the cost rate for removing material in a typical finish cut (1-4 m-hrs/lb).

* B - Baseline
REFERENCES: Tables A-I and A-IV

FIGURE A-10 DESIGN ANALYSIS GUIDELINE NO. 4, ALUMINUM

DESIGN ANALYSIS GUIDELINE

NO. 5

SUBJECT: DESIGN PERMITTING LARGER FINISH CUTTERS
MATERIAL: ALUMINUM

TYPE OF PART: LARGE MULTIPOCKET BULKHEAD OR SPAR
MACHINING PROCESS: END MILLING

GUIDELINE: Designing pocket corners with a 0.5-inch radius instead of the usual 0.375 permits using a stiffer cutter capable of higher feed rates and fewer passes on the side and corners. Heavier corners increase part weight 1-2%, but cost reduces 4-6%. Avoiding the weight increase requires 15-20 man-hrs/lb., many times the part average rate.

ILLUSTRATION:

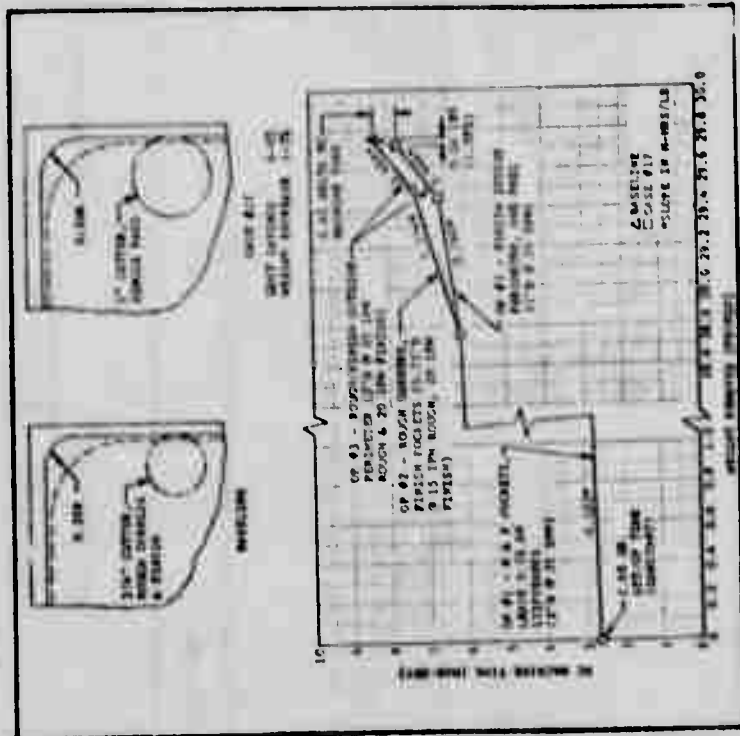

SUPPORTING DATA

COST ANALYSIS OF COMPARISON PARTS

NC Type	Case	Case	Case
Operation (Machined) at Cost Item	Case 1	Case 2	Case 3
#1: 3/16" pocket, 1.5" dia, 1.5" deep, 1.5" dia, 1.5" deep	1.17	1.17	1.17
#2: Baseline 3/16" pocket, 1.5" dia, 1.5" deep	1.17	1.17	1.17
#3: 3/16" pocket, 1.5" dia, 1.5" deep	1.17	1.17	1.17
#4: 3/16" pocket, 1.5" dia, 1.5" deep	1.17	1.17	1.17
#5: 3/16" pocket, 1.5" dia, 1.5" deep	1.17	1.17	1.17
#6: 3/16" pocket, 1.5" dia, 1.5" deep	1.17	1.17	1.17
#7: 3/16" pocket, 1.5" dia, 1.5" deep	1.17	1.17	1.17
#8: 3/16" pocket, 1.5" dia, 1.5" deep	1.17	1.17	1.17
#9: 3/16" pocket, 1.5" dia, 1.5" deep	1.17	1.17	1.17
#10: 3/16" pocket, 1.5" dia, 1.5" deep	1.17	1.17	1.17
#11: 3/16" pocket, 1.5" dia, 1.5" deep	1.17	1.17	1.17
#12: 3/16" pocket, 1.5" dia, 1.5" deep	1.17	1.17	1.17
#13: 3/16" pocket, 1.5" dia, 1.5" deep	1.17	1.17	1.17
#14: 3/16" pocket, 1.5" dia, 1.5" deep	1.17	1.17	1.17
#15: 3/16" pocket, 1.5" dia, 1.5" deep	1.17	1.17	1.17
#16: 3/16" pocket, 1.5" dia, 1.5" deep	1.17	1.17	1.17
#17: 3/16" pocket, 1.5" dia, 1.5" deep	1.17	1.17	1.17
#18: 3/16" pocket, 1.5" dia, 1.5" deep	1.17	1.17	1.17
#19: 3/16" pocket, 1.5" dia, 1.5" deep	1.17	1.17	1.17
#20: 3/16" pocket, 1.5" dia, 1.5" deep	1.17	1.17	1.17
#21: 3/16" pocket, 1.5" dia, 1.5" deep	1.17	1.17	1.17
#22: 3/16" pocket, 1.5" dia, 1.5" deep	1.17	1.17	1.17
#23: 3/16" pocket, 1.5" dia, 1.5" deep	1.17	1.17	1.17
#24: 3/16" pocket, 1.5" dia, 1.5" deep	1.17	1.17	1.17
#25: 3/16" pocket, 1.5" dia, 1.5" deep	1.17	1.17	1.17
#26: 3/16" pocket, 1.5" dia, 1.5" deep	1.17	1.17	1.17
#27: 3/16" pocket, 1.5" dia, 1.5" deep	1.17	1.17	1.17
#28: 3/16" pocket, 1.5" dia, 1.5" deep	1.17	1.17	1.17
#29: 3/16" pocket, 1.5" dia, 1.5" deep	1.17	1.17	1.17
#30: 3/16" pocket, 1.5" dia, 1.5" deep	1.17	1.17	1.17
#31: 3/16" pocket, 1.5" dia, 1.5" deep	1.17	1.17	1.17
#32: 3/16" pocket, 1.5" dia, 1.5" deep	1.17	1.17	1.17
#33: 3/16" pocket, 1.5" dia, 1.5" deep	1.17	1.17	1.17
#34: 3/16" pocket, 1.5" dia, 1.5" deep	1.17	1.17	1.17
#35: 3/16" pocket, 1.5" dia, 1.5" deep	1.17	1.17	1.17
#36: 3/16" pocket, 1.5" dia, 1.5" deep	1.17	1.17	1.17
#37: 3/16" pocket, 1.5" dia, 1.5" deep	1.17	1.17	1.17
#38: 3/16" pocket, 1.5" dia, 1.5" deep	1.17	1.17	1.17
#39: 3/16" pocket, 1.5" dia, 1.5" deep	1.17	1.17	1.17
#40: 3/16" pocket, 1.5" dia, 1.5" deep	1.17	1.17	1.17
#41: 3/16" pocket, 1.5" dia, 1.5" deep	1.17	1.17	1.17
#42: 3/16" pocket, 1.5" dia, 1.5" deep	1.17	1.17	1.17
#43: 3/16" pocket, 1.5" dia, 1.5" deep	1.17	1.17	1.17
#44: 3/16" pocket, 1.5" dia, 1.5" deep	1.17	1.17	1.17
#45: 3/16" pocket, 1.5" dia, 1.5" deep	1.17	1.17	1.17
#46: 3/16" pocket, 1.5" dia, 1.5" deep	1.17	1.17	1.17
#47: 3/16" pocket, 1.5" dia, 1.5" deep	1.17	1.17	1.17
#48: 3/16" pocket, 1.5" dia, 1.5" deep	1.17	1.17	1.17
#49: 3/16" pocket, 1.5" dia, 1.5" deep	1.17	1.17	1.17
#50: 3/16" pocket, 1.5" dia, 1.5" deep	1.17	1.17	1.17
#51: 3/16" pocket, 1.5" dia, 1.5" deep	1.17	1.17	1.17
#52: 3/16" pocket, 1.5" dia, 1.5" deep	1.17	1.17	1.17
#53: 3/16" pocket, 1.5" dia, 1.5" deep	1.17	1.17	1.17
#54: 3/16" pocket, 1.5" dia, 1.5" deep	1.17	1.17	1.17
#55: 3/16" pocket, 1.5" dia, 1.5" deep	1.17	1.17	1.17
#56: 3/16" pocket, 1.5" dia, 1.5" deep	1.17	1.17	1.17
#57: 3/16" pocket, 1.5" dia, 1.5" deep	1.17	1.17	1.17
#58: 3/16" pocket, 1.5" dia, 1.5" deep	1.17	1.17	1.17
#59: 3/16" pocket, 1.5" dia, 1.5" deep	1.17	1.17	1.17
#60: 3/16" pocket, 1.5" dia, 1.5" deep	1.17	1.17	1.17
#61: 3/16" pocket, 1.5" dia, 1.5" deep	1.17	1.17	1.17
#62: 3/16" pocket, 1.5" dia, 1.5" deep	1.17	1.17	1.17
#63: 3/16" pocket, 1.5" dia, 1.5" deep	1.17	1.17	1.17
#64: 3/16" pocket, 1.5" dia, 1.5" deep	1.17	1.17	1.17
#65: 3/16" pocket, 1.5" dia, 1.5" deep	1.17	1.17	1.17
#66: 3/16" pocket, 1.5" dia, 1.5" deep	1.17	1.17	1.17
#67: 3/16" pocket, 1.5" dia, 1.5" deep	1.17	1.17	1.17
#68: 3/16" pocket, 1.5" dia, 1.5" deep	1.17	1.17	1.17
#69: 3/16" pocket, 1.5" dia, 1.5" deep	1.17	1.17	1.17
#70: 3/16" pocket, 1.5" dia, 1.5" deep	1.17	1.17	1.17
#71: 3/16" pocket, 1.5" dia, 1.5" deep	1.17	1.17	1.17
#72: 3/16" pocket, 1.5" dia, 1.5" deep	1.17	1.17	1.17
#73: 3/16" pocket, 1.5" dia, 1.5" deep	1.17	1.17	1.17
#74: 3/16" pocket, 1.5" dia, 1.5" deep	1.17	1.17	1.17
#75: 3/16" pocket, 1.5" dia, 1.5" deep	1.17	1.17	1.17
#76: 3/16" pocket, 1.5" dia, 1.5" deep	1.17	1.17	1.17
#77: 3/16" pocket, 1.5" dia, 1.5" deep	1.17	1.17	1.17
#78: 3/16" pocket, 1.5" dia, 1.5" deep	1.17	1.17	1.17
#79: 3/16" pocket, 1.5" dia, 1.5" deep	1.17	1.17	1.17
#80: 3/16" pocket, 1.5" dia, 1.5" deep	1.17	1.17	1.17
#81: 3/16" pocket, 1.5" dia, 1.5" deep	1.17	1.17	1.17
#82: 3/16" pocket, 1.5" dia, 1.5" deep	1.17	1.17	1.17
#83: 3/16" pocket, 1.5" dia, 1.5" deep	1.17	1.17	1.17
#84: 3/16" pocket, 1.5" dia, 1.5" deep	1.17	1.17	1.17
#85: 3/16" pocket, 1.5" dia, 1.5" deep	1.17	1.17	1.17
#86: 3/16" pocket, 1.5" dia, 1.5" deep	1.17	1.17	1.17
#87: 3/16" pocket, 1.5" dia, 1.5" deep	1.17	1.17	1.17
#88: 3/16" pocket, 1.5" dia, 1.5" deep	1.17	1.17	1.17
#89: 3/16" pocket, 1.5" dia, 1.5" deep	1.17	1.17	1.17
#90: 3/16" pocket, 1.5" dia, 1.5" deep	1.17	1.17	1.17
#91: 3/16" pocket, 1.5" dia, 1.5" deep	1.17	1.17	1.17
#92: 3/16" pocket, 1.5" dia, 1.5" deep	1.17	1.17	1.17
#93: 3/16" pocket, 1.5" dia, 1.5" deep	1.17	1.17	1.17
#94: 3/16" pocket, 1.5" dia, 1.5" deep	1.17	1.17	1.17
#95: 3/16" pocket, 1.5" dia, 1.5" deep	1.17	1.17	1.17
#96: 3/16" pocket, 1.5" dia, 1.5" deep	1.17	1.17	1.17
#97: 3/16" pocket, 1.5" dia, 1.5" deep	1.17	1.17	1.17
#98: 3/16" pocket, 1.5" dia, 1.5" deep	1.17	1.17	1.17
#99: 3/16" pocket, 1.5" dia, 1.5" deep	1.17	1.17	1.17
#100: 3/16" pocket, 1.5" dia, 1.5" deep	1.17	1.17	1.17

Total Cost, Manhours 13.50 12.84 - 0.66
 Weight of Comparison Part, Lbs. 2.53 2.57 + 0.04
 Average Manhours per Pound Removed 0.4535 0.4320

Δ Change in Total Cost - 4.89%
 Δ Change in Weight of Part + 1.58%

Cost of Avoiding Weight Increase = 0.66/0.04 = 16.50 m-hr/lb.

DISCUSSION

Finish cuts on pocket sides and corners are usually done with a 3/16" D cutter. Using a 1" D cutter instead removes 80% as much excess material as a 3/16" D does and permits higher feed rates on the sides and a single pass in the corners. The effectiveness of various cutting operations is demonstrated by the illustration. Operation #1 removes 80% of the material to be removed in 60% of the time. Operation #2 and #3 remove 82, 20, 40% of the time. Finish operations (#2 and #3) are therefore highly cost sensitive. Comparing the conventional 3/16" D cutter with the proposed 1" D cutter for the #2 finish cut in terms of the slope of each line, or removal rate, the 1" D removes 2.76 lbs. in 1.17 hours or 2.36 m-hr/lb., vs. 0.70 lbs. in 0.12 hours or 0.24 m-hr/lb. for the 3/16" D. Thus, the 1" D cutter is 1.23 more efficient than the 3/16" D cutter and not using it is at a rate penalty of 0.45/0.04 = 11.3 man-hours per pound removed, the slope of the line between the two end points illustrated.

REFERENCES:

Table A-1 and A-IV

FIGURE A-11 DESIGN ANALYSIS GUIDELINE NO. 5, ALUMINUM

DESIGN ANALYSIS GUIDELINE

NO. 6

TYPE OF PART: LARGE MULTIPURPOSE WHEELS OR SPARS

SUBJECT: REDUCED HAND FINISHING DUE TO RELAXED DIMENSIONAL TOLERANCE

MACHINING PROCESS: END MILLING

MATERIAL: ALUMINUM

GUIDELINE: It is recommended that dimensional tolerances on aluminum-machined webs be held at the current conventional ± 0.010 , and that tolerances on stiffeners and flanges be relaxed to ± 0.015 , ± 0.010 . This may cause a weight increase of up to 0.7% above current weight, but will reduce part total cost by 2%. The cost of avoiding the weight increase is roughly 30 cents/pound per pound.

ILLUSTRATION:

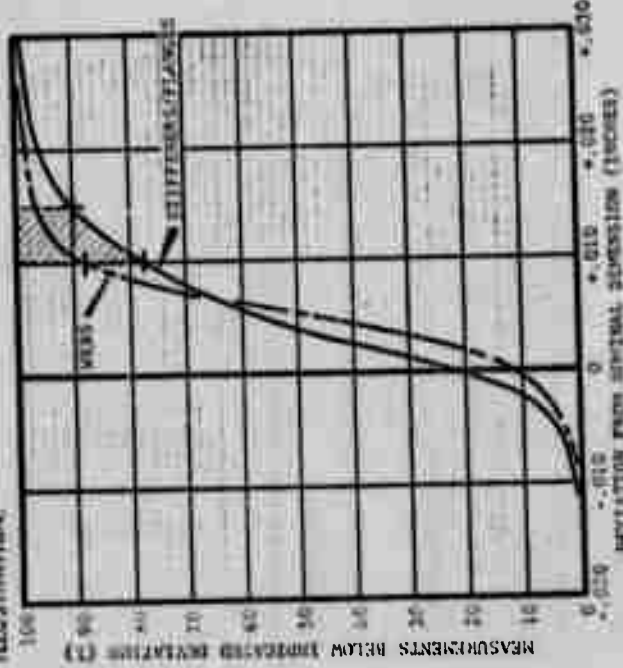

DISCUSSION: (Cont'd)
 For case #1, a 11.0113, .45 or 67% of the baseline, the resulting 37% (100-63) reduced cost of hand finish for dimensional control saves 2% of total part cost. The cost of avoiding the weight increase (28.6 mil/lb) indicates that relaxing dimensional tolerance on stiffeners and flanges is highly cost effective.

SUPPORTING DATA:

COST ANALYSIS OF COMPARISON PARTS

NC Type	Case #1	Case #2	Δ Cost
Operation (Minutes) or Cost Item			
NC set-up time	4.38	4.38	0
NC run time	0.72	0.72	0
Setup	1.05	1.05	0
Surface finish	0.24	0.45	-0.21
R.P. for dimensions (30% done)	2.83	2.83	0
All other costs	13.50	13.23	-0.27
Total Cost, Man-Hours	7.53	7.53	0.00
Weight of Comparison Part, lbs			
% Change in Total Cost			+2.0%
% Change in Weight of Part			+0.3%
Cost of avoiding the weight increase, \$/lb			38.6

$\bar{x} = 0$ Baseline

DISCUSSION: The adjacent illustration was constructed from data gathered from production spars and bulkheads designed generally with dimensional tolerances of ± 0.010 and for NC machining. The data reflects 1000 web thickness measurements and 800 stiffener/flange measurements. The illustration indicates that for the conventional ± 0.010 tolerance (77.2% of all stiffener/flanges and 88% of all webs are acceptable). If the tolerance for stiffener/flanges is relaxed to ± 0.015 , ± 0.010 , the acceptable dimensional deviations increase to 95%. It is recommended, therefore, that new design of webs be held to the current ± 0.010 . On stiffeners and flanges, tolerances should be relaxed to ± 0.015 , ± 0.010 .

The accompanying weight increase that may occur in stiffeners and flanges can be estimated from the adjacent illustration. The net area between the curves and the zero dimensional deviation line represents EXCESS thickness deviation from the nominal dimension. The area under the stiffener/flange curve between ± 0.010 and ± 0.015 deviation lines represents, therefore, the average thickness increase as a result of tolerance relaxation and measures to square were omitted resulting in the 0.00078 thickness increase (29.1 x 0.0002) a survey of P-16 production drawings revealed that stiffener and flanges represent 72% of total part weight and have an average thickness of 0.155 inch. The weight increase on stiffeners is determined as a percentage of total part weight (total part weight being calculated using nominal dimensions):

Weight Increase = $0.00078 / 0.155 \times 100 = 0.50\%$ of total part weight. Actual weight increase for case #1 is 0.001 pounds (0.005 x 2.53). It is to be noted that the baseline weight of 2.53 reflects nominal dimensions, therefore the case #1 weight of 2.537 represents a weight increase of 0.010 to ± 0.015 .

The illustration shows that hand-finishing for dimensional control of ± 0.010 (baseline part) is required on 22% of the webs and 77% of stiffener/flanges, or an average of 17.3% of total part. By relaxing tolerance of stiffeners and flanges, only 10% require hand-finishing and results in an average part weight of 11.0%. The amount of hand-finish required, therefore,

DESIGN ANALYSIS GUIDELINE NO. 6, ALUMINUM

FIGURE A-12

DESIGN ANALYSIS GUIDELINE

NO. 1

TYPE OF PART: LARGE MULTIPOCKET BULKHEAD OR SPAR

SUBJECT: FLANGED VS VERTICAL STIFFENERS

MACHINING PROCESS: END MILLING

MATERIAL: TITANIUM

GUIDELINE: A vertical stiffener up to a maximum height equal to the plate thickness should be used before considering a flanged stiffener. An "L" shaped stiffener will cost 7-8% more, and a "T" shaped stiffener will cost 14-16% more than a vertical stiffener in plates of equal thickness. Only when more stiffness is needed than the vertical stiffener can provide, should a flanged stiffener be used.

ILLUSTRATION:

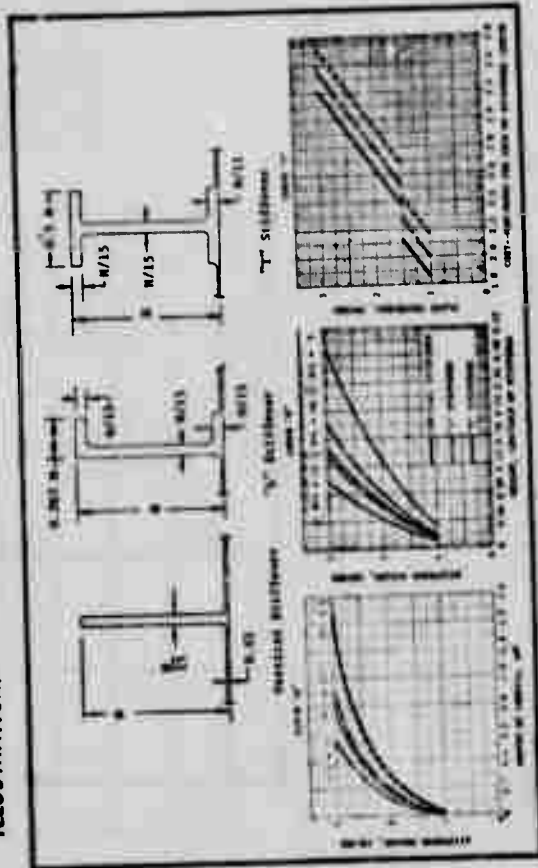

SUPPORTING DATA:

COST ANALYSIS OF COMPARISON PARTS

NC Tape Operation (Minimum of Cost Item)	Case #1	Case #2	Case #3	ΔCost
1	105	90	127	
2	11	22	42	
3 (See Table A-V for description)	41	42	281	
4	30	33	33	

Man-hours	Material	Cost*/Tech
39.83	34.81	2.275
	51.32	2.138
	62.37	2.657
	58.80	2.656

Case	Cost*	Material	Cost*/Tech
T1 (1.5" L)	33.36	34.81	2.275
Baseline (1.5" Vertical)	30.85	51.32	2.138
T2 (2.03" Vertical)	35.23	62.37	2.657
1.5" Tee	38.13	58.80	2.656

* Cost in man-hours
 † Cost = 13.78 m-hrs per inch of thickness of cost comparison part
 ‡ Note: The above data forms the basis for Curve "C."

DISCUSSION: When the plate thickness exceeds approximately 1.5", an extra pass of the 2.0" B roughing cutter is required and results in a step in the cost curve (Curve "C"). The flanged stiffeners cost more because the material under the flange of the stiffener is removed with an extra operation using a re-cutter at a less efficient material removal rate than when the equivalent material is removed for a vertical stiffener.

Curves "A," "B," and "C" show amount of inertia, weight and cost for the stiffener shapes shown in the illustration. Feed rates were constant for all plate thicknesses. The proportions suggested are considered only optimum for structural efficiency. Vertical stiffeners with $H/t = 15$ are more difficult to machine so this upper limit was set. Curves are shown for vertical stiffeners of $H/t = 10$ and 5 also. Material cost, converted to man-hours, is included in the cost curve.

The following steps should be followed when using the curves:

1. Knowing H/t required, enter curve "A" and select (a) the tallest vertical stiffener and (b) the tallest "L" or "T" stiffener to meet the H/t requirement.
2. Read weights from Curve "B"
3. Read Cost from Curve "C"
4. Knowing weight & costs of the two stiffeners and program weight/cost guideline, the appropriate stiffener can be selected.

REFERENCES: Tables A-V and A-VIII

FIGURE A-13 DESIGN ANALYSIS GUIDELINE NO. 1, TITANIUM

DESIGN ANALYSIS GUIDELINE

NO. 2

SUBJECT: LANDS VS. NO LANDS ON POCKET WEBS

MATERIAL: TITANIUM

TYPE OF PART: LARGE MULTIPOCKET BULKHEAD OR SPAR

MACHINING PROCESS: END MILLING

GUIDELINE: Where a titanium pocket web thickness is dictated by fuel pressure strength requirements at web edge, the designer must choose between a complete web of the required thickness and a "land" of that same thickness surrounding a thinner web area. The "land" approach is 10-15% lighter and 6-8% more costly for typical cases. The cost rate of additional weight removal is 2-4 man-hours/pound, considerably lower than typical finish machining costs for titanium. Lands should be used when loads permit.

ILLUSTRATION:

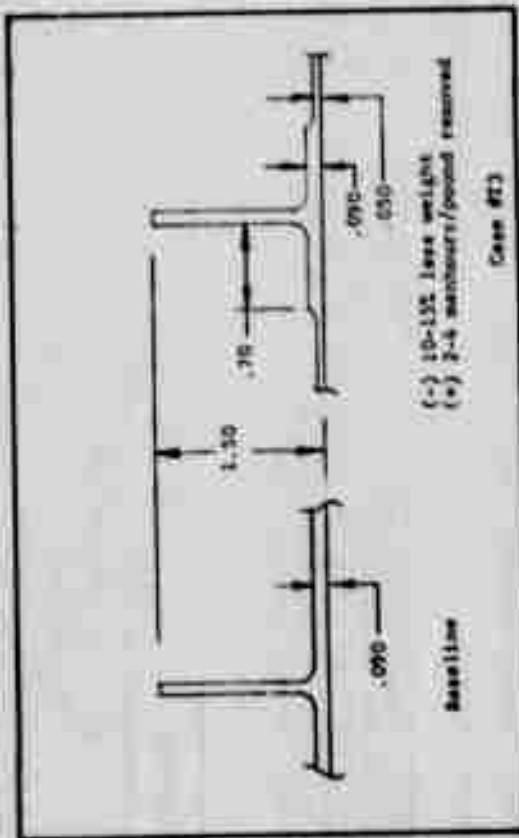

SUPPORTING DATA:

COST ANALYSIS OF COMPARISON PARTS

NC Tape Description	Case # 13	Case # 105	Case # 136	Case # 266	Δ Cost
1. (See Table A-V for description)	89	94	41	266	- 16
2.					+ 42
3.					0
		240			+ 26

Total Cost, Man-Hours 30.65 32.75 + 2.10
 Weight of Comparison Part, lbs 5.320 4.608 - 0.712
 Manhours per Pound Removed (Avg) 0.6511 0.6957 + 0.035

% Change in Total Cost + 6.85%
 Cost of saving weight = 2.10/0.712 = 2.95 m-h/lb.
 % Change in Weight of Part - 13.42%

* Baseline in this case is assumed to have a web of 0.090" equal to the thickness of the land in Case 13, in order to illustrate the Designers options in a typical case.

DISCUSSION: On pocket webs loaded by fuel pressure or other types of varying pressure loads, the edge of web is usually critical in fatigue. A structurally efficient provision commonly employed is a "land" surrounding a thinner web, providing a local increase in thickness and flexing strength. To make the entire web the same thickness is less costly but adds 10-15% to the weight of a typical part. The "land" design is 6-8% more costly because of the additional machining and edge trimming of the thin part of the web bordered by the land; however, finish machining titanium is typically 6-7 man-hours per pound removed whereas avoiding this weight increase is at only 2-4 man-hours/pound. The designer should consider these aspects in his trade-offs.

REFERENCES: Tables A-V and A-VIII

FIGURE A-14 DESIGN ANALYSIS GUIDELINE NO. 2, TITANIUM

DESIGN ANALYSIS GUIDELINE

NO. 3

TYPE OF PART: LARGE MULTIPOCKET BULKHEAD OR SPAR

MACHINING PROCESS: END MILLING

SUBJECT: RELAXED TOLERANCES & RADII ON LANDS

MATERIAL: TITANIUM

GUIDELINE: "Lands" are provided to reinforce the edge of a 0.040-0.050 web. A designer can save 8-12 percent of the part cost by permitting a 1-inch land corner radius and a ± 0.05 tolerance on land width rather than the 0.38 R and ± 0.03 inch usually required. Weight increases 0.3%. Cost of avoiding the weight increase is extremely high.

ILLUSTRATION:

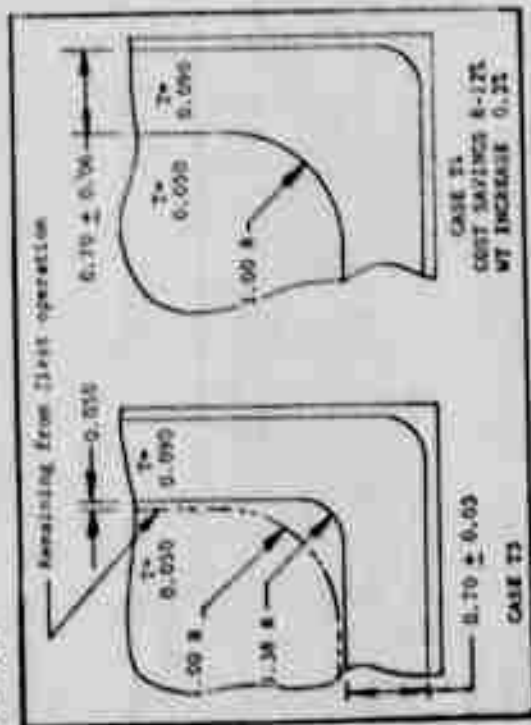

SUPPORTING DATA:

COST ANALYSIS OF COMPARISON PARTS

NC Tape Operation (Minutes of Cost Item)	Case	Case
1	89	90
2	136	94
3	41	41
	265	225

(See Table A-V for description)

Total Cost, Man-Hours: 32.75 29.55 ± 1.20
 Weight of Comparison Part, lbs: 4.508 4.622 ± 0.114
 Man-hours per Pound Removed (Avg.): 0.6557 0.6281

% Change in Total Cost: - 9.8%
 % Change in Weight of Part: + 0.3%

Cost Rate of Avoiding Added Weight:
 Man-hrs/Lb = 3.20/0.014 = 228.5

DISCUSSION: A "land" is produced by rough machining to land depth over the area of a pocket then by machining typically 0.04" deeper to web depth leaving the land around the edges. The first operation usually leaves 0.05" extra on the land width and a 1" radius in the pocket corner of the land. A finish operation with a 3/4" D cutter trims this material away.

By not performing the trim operation, 8-12% of the cost is saved at a weight penalty of 0.3% for the part. The designer must then design with a 1" corner land radius and a more generous tolerance on the land width, i.e., ± 0.06 .
 The cost of removing the 0.3% added weight is at the rate of 229 man-hours per pound, many times the average rate for the part.

REFERENCES: Tables A-V and A-VIII

FIGURE A-15 DESIGN ANALYSIS GUIDELINE NO. 3, TITANIUM

DESIGN ANALYSIS GUIDELINE

NO. 4

TYPE OF PART: LARGE MULTIPOCKET BULKHEAD OR SPAR

MACHINING PROCESS: END MILLING

SUBJECT: EXCESSIVE HEIGHT/THICKNESS RATIO ON STIFFENERS

MATERIAL: TITANIUM

GUIDELINE: Designing to save weight by use of stiffener height/thickness ratio above 15 increases cost 9-14 percent due to additional required finish passes by the cutter. Weight saved, however, is 5-6 percent for a typical case.

Height avoidance costs roughly 14 man-hours/lb, compared with typical finish cost of 6-7 man-hours/lb.

ILLUSTRATION:

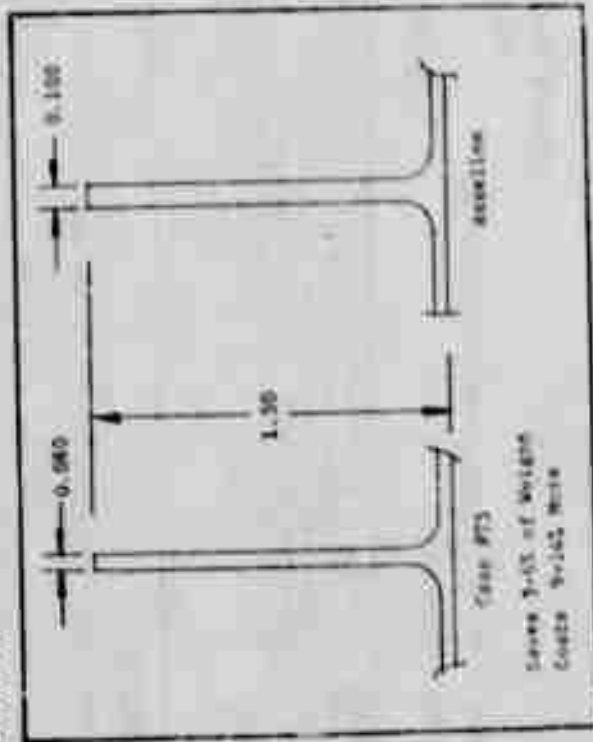

SUPPORTING DATA:

COST ANALYSIS OF COMPARISON PARTS

NC Tape	Material (Man-hours of Cost Used)	Case	ΔCost
1	109	15	+ 1
2	94	106	+ 40
3	312	133	+ 1
	312	42	+ 41

(See Table A-V for Description)

Total Cost, Man-Hours 30.55 33.82 + 3.17
 Weight of Comparison Part, lbs 4.053 3.826 - 0.227
 Manhours per Pound Removed (Avg.) 0.6436 0.7068 + 0.0632

% Change in Total Cost + 10.34%

% Change in Man-Hours/lb - 5.6%

% Change in Weight of Part

Cost Rate of Removing Weight Saved,
 Man-hrs/lb = 3.17/0.227 = 13.96

* B = Baseline

DISCUSSION: The additional cost required to machine a 1.5" x 0.080" stiffener rather than one with the practical minimum of 1.5" x 0.100" is 9-14% due to the need for additional finish cuts (Oper #2). Cost would increase further if stiffener were taller due to increased plate thickness (see Guideline #1). Also, the probability of damage by cutter increases as height/thickness increases due to part flexibility. Weight difference, however, is relatively significant, 5-6%.

Trade-off analysis should consider the 5-6% weight increase against the 14 man-hours/lb cost of removing the weight which is much higher than the typical finish machining cost of 6-7 man-hours/lb

REFERENCES: Tables A-V and A-VIII

FIGURE A-16 DESIGN ANALYSIS GUIDELINE NO. 4, TITANIUM

DESIGN ANALYSIS GUIDELINE
NO. 5

SUBJECT: DESIGN PERMITTING LARGER FINISH CUTTERS
MATERIAL: TITANIUM
TYPE OF PART: LARGE MULTIPOCKET BULKHEAD OR SPAR
MACHINING PROCESS: END MILLING

GUIDELINE: Designing pocket corners with a 0.5 inch radius instead of the usual 0.38 radius permits using a stiffer cutter capable of higher feed rates and fewer passes on the sides and corners. Heavier corners increase part weight 1-2%, but cost reduces 4-6%. Avoiding the weight increase costs 25 man-hours per pound.

ILLUSTRATION:

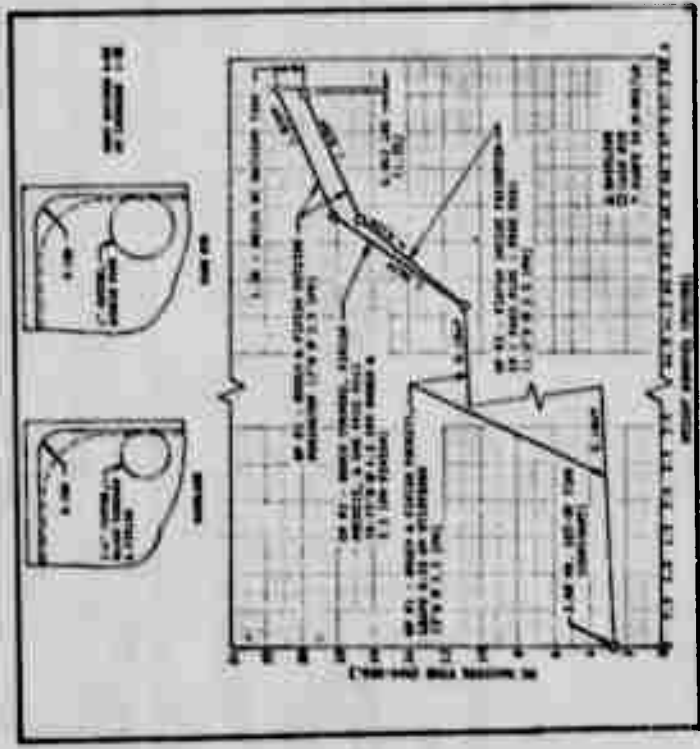

FIGURE A-17 DESIGN ANALYSIS GUIDELINE NO. 5, TITANIUM

SUPPORTING DATA:

COST ANALYSIS OF COMPARISON PARTS			
NC Type	Case	Case	ΔCost
Operational (Number) or Cost Limit	Ø B	Ø 1/8	
1	105	105	0
2	94	74	- 20
3	41	41	0
	240	220	- 20

(See Table A-V for description)

Total Cost, Man-Hours 30.65 29.11 - 1.54
 Weight of Comparison Part, lbs 4.053 4.115 + 0.062
 Manhours per Pound Removed (Avg.) 0.6436 0.6123

% Change in Total Cost - 5.0%

% Change in Weight of Part + 1.5%

Cost of Avoiding Weight Increase = 1.54/0.062 = 24.8 a-hrs/lb.

DISCUSSION: Finish cuts on pocket sides and corners are usually done with a 3/4" D cutter. Using a 1" D cutter instead removes 88% as much corner material as a 3/4" D does and permits higher feed rates on the sides and a single pass in the corners.

The effectiveness of various cutting operations is demonstrated by the illustration. Operation #1 removes 96% of the material to be removed in 48% of the time. Operations #2 and #3 remove 4% in 52% of the time. Finish operations (#2 and #3) are therefore highly cost sensitive. Comparing the conventional 3/4" D cutter with the proposed 1" D cutter for the Ø2 finish cut in terms of the slope of each line, or removal cost rate, the 3/4" D removes 1.23 lbs in 7.33 hours or 5.963 a-hrs/lb, vs 1.17 lbs in 5.27 hours or 5.932 a-hrs/lb for the 1" D. Thus, the 1" D cutter is 23% more efficient than the 3/4" D cutter is; and not using it is at a rate penalty of 1.56/0.062 = 25.2 man-hours per pound removed, the slope of the line between the two end points illustrated.

REFERENCES: Tables A-V and A-VIII

design. One such is the simple one of what the corner radius of pockets should be in integrally stiffened spars and bulkheads. It is common knowledge that the larger radius is less costly to machine, but it does, of course, leave a significant amount of weight in the part, usually up to 1-1½ percent of the part weight. Not knowing how much less costly, and being pressed to achieve minimum weight, the designer usually decides on the smallest radius he believes to be practical.

From analysis of numerical control (NC) programming and factory machining cost data, the following approach was derived to aid in trade-off decisions. An aircraft design program will sometimes establish a weight/cost trade-off value, i.e., how many dollars it is worth spending to save a pound of weight. Comparison of the trade-off value with the cost in man-hours times the factory hourly rate to remove one pound would then permit a decision.

5.3.2 Discussion

Because a 1-inch diameter end mill is over three times as stiff as a ¾-inch cutter, the larger cutter can mill finish cuts alongside stiffeners and flanges 50-100 percent faster and can remove corner material left by a 2-inch diameter rough cutter in one pass where the ¾-inch requires two passes. The 1-inch cutter does, however, leave more corner material. This raises the question as to whether the cost saving per additional pound remaining is cost effective.

The following data offers an estimate of the average cost saving per pound. Machining cost of a part is seldom the same from part to part and variation can be as much as 100 percent. Cost factors used herein are, therefore, statistical with a measured scatter. They are based on some 30 F-111 aluminum part numbers with an average of 51 manufactured pieces per part number.

Numerical control (NC) machine time per part as used herein and as charged in factory accounting includes all productive (actual machining) as well as unproductive time charges such as set-up and tear-down of tooling, cutter changes, machine and tape malfunctions, material problems, rest periods, shift changes, operator tape override, etc.

The real time it takes an NC-programmed tape to run through its entire operation is, of course, much less than machine time due to all of the foregoing unproductive events, but the ratio of NC machine time to NC tape time is constant enough to be a

practical means for scheduling the NC machine shop. Analysis of the 30 part numbers machine time to tape time ratio yields an average of 7.33 with a standard deviation of 2.58 or 35.1 percent of the mean for an average of 51 pieces per part number. From the 7.33 average and a 90 percent learning curve (reflecting NC experience), the first part cost ratio would be 11.435, and a cost ratio representative of an average part for a 1000 aircraft program would be 4.71 which will be used herein. These cost ratios reflect the total NC machine time which includes part set-up, cutter changes, part removal, clean-up, etc. Production planning assumes that these non-productive operations consume 32% of the total machine time. To obtain a true ratio between machine run-time and tape time, the total machine time must be reduced to 68% of the total. The true cost ratio representative of an average part for a 1000 aircraft program would then be 0.68×4.71 or 3.20.

An NC program is created by putting together many standard program segments or computer instructions which are modified for the geometry of the part involved. A cutter making a radial finish cut proceeds along a stiffener removing typically 0.030 inch of material from each side left by the roughing cutter. When it approaches a corner where it must change direction, it decelerates to a complete stop, dwells stationary for a finite interval and accelerates in the new direction to the programmed feed rate again, rotating and cutting at a constant rpm throughout.

In addition, if the cutter is below a certain diameter, it may have to repeat the cutting operation in the corners where a substantial thickness is left by the large roughing cutter.

For the purpose of this program, a sample part with typical features was fully programmed by factory programmers using programming techniques and feed rates typical of production parts. Programming was done using a variety of cutter sizes and radial cuts, both conventional and unconventional. These programs were then printed out by the computer, and each machining step was analyzed in terms of time duration, feed rate, metal removal rate and other characteristics. From this data, the time required by various cutter diameters to machine various features including corners was determined. The values used for the various parameters described below were obtained from this source.

Taking a single pocket, Figure A-18, the following relationships can be established:

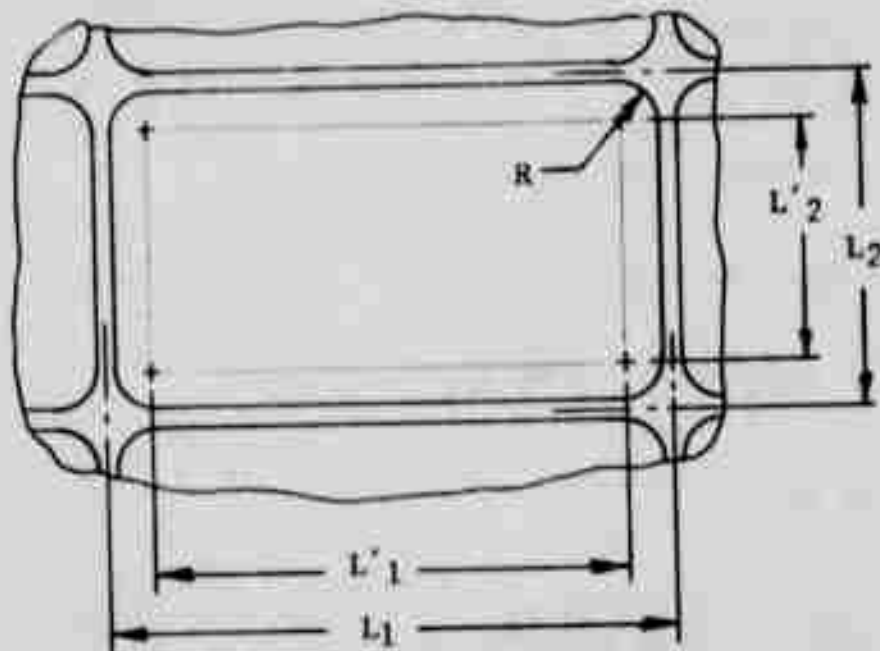

FIGURE A-18 SAMPLE ANALYTICAL PART-COST ANALYSIS FOR TWO DIFFERENT CORNER RADII

$$L_1 = L'_1 + 2R$$

$$L_2 = L'_2 + 2R$$

$$2L_1 + 2L_2 = 2L'_1 + 4R + 2L'_2 + 4R, \text{ or}$$

$$\Sigma L = \Sigma L' + 8R \text{ for one pocket}$$

Let $\Sigma L = L$ be the sum of the length of all sides, N_c be the number of corners to be finish machined on the entire part, and $\Sigma L' = L'$ be the sum of all cutter centerline travel. Then

$$L = L' + 8R \left(\frac{N_c}{4} \right)$$

$$L = L' + 2R N_c$$

$$L' = L - 2R N_c \quad (A1)$$

From the NC program of the sample part, the NC tape time required for a 3/4-inch diameter, 2-inch long, 2-flute HSS cutter to finish machine the pockets was analyzed as follows:

t_1 = total NC tape time = 9.0 minutes

N_c = 12 for 3 pockets

L = 106 inches

R = 0.38 inch

f_1 = 20 inches per minute

$$t_1 = \frac{L'}{f_1} + N_c t_{c1}$$

$$= \frac{L - 2 R_1 N_c}{f_1} + N_c t_{c1} \quad (A2)$$

Solving for t_{c1}

$$\begin{aligned} t_{c1} &= \frac{t_1}{N_c} - \frac{L - 2 R_1 N_c}{f_1 N_c} \\ &= \frac{9.0}{12} - \frac{106 - 2 \times 0.38 \times 12}{20 \times 12} \\ &= 0.3463 \text{ minutes per corner} \end{aligned}$$

In the same manner, for a 1-inch diameter cutter to finish machine the same part, the total time, t_2 , was 4.0 minutes, R_2 = 0.50 inch and f_2 = 30 inches per minute.

$$t_2 = \frac{L - 2 R_2 N_c}{f_2} + N_c t_{c2}$$

$$t_{c2} = 0.0722 \text{ minutes per corner} \quad (A3)$$

These time estimates for corner machining should be typical for aluminum for up to 1.5-inch deep pockets for 2-inch long 3/4-inch and 1-inch diameter cutters. At first glance the difference in time between the two cutters to machine one corner appears excessive; however, the 3/4-inch cutter not only machines corners at a lower feed rate but must also make two passes and requires additional time for "free" travel (no cutting) between corners for the second pass.

The total part difference in weight is:

$$\Delta W = \Delta A N_c h \rho \quad (A4)$$

The cost penalty of avoiding the weight increase associated with the larger corner radius in man-hours per pound is then:

$$\frac{\Delta C}{1b} = \frac{R_{NC}}{60} \times \left(\frac{t_1 - t_2}{\Delta W} \right) \quad (A5)$$

Substituting equations A2, A3 and A4 in A5 yields:

$$\frac{\Delta C}{1b} = \frac{R_{NC}}{60} \left[\frac{\left(\frac{L - 2R_1 N_c}{f_1} + N_c t_{c1} \right) - \left(\frac{L - 2R_2 N_c}{f_2} + N_c t_{c2} \right)}{\Delta A N_c h \rho} \right]$$

$$\frac{\Delta C}{1b} = \frac{R_{NC}}{60 \Delta A h \rho} \left[\frac{L}{N_c} \left(\frac{1}{f_1} - \frac{1}{f_2} \right) + 2 \left(\frac{R_2}{f_2} - \frac{R_1}{f_1} \right) + (t_{c1} - t_{c2}) \right] \quad (A6)$$

Applying equation A6 to an aluminum part with pocket depth h , N_c corners, L total length, and R_{NC} cost ratio:

$$\rho = 0.10$$

$$R_1 = 0.38$$

$$R_2 = 0.50$$

$$\Delta A = 0.0236$$

$$f_1 = 20$$

$$f_2 = 30$$

$$t_{c1} = 0.3463$$

$$t_{c2} = 0.0722$$

$$\frac{\Delta C}{1b} = \frac{R_{NC}}{h} \left(0.1179 \frac{L}{N_c} + 1.9032 \right) \quad (A7)$$

Applying a ratio representing the average for 1000 units so as to measure program impact, $R_{NC} = 3.20$ (set-up time deleted). Equation A7 then becomes:

$$\frac{\Delta C}{1b} = \frac{1}{h} \left(0.3773 \frac{L}{N_c} + 6.0902 \right) \quad (A8)$$

The trade-off cost value is plotted in Figure A-19 for $h = 1.0$ and 1.50 . A designer need only determine the number of inches of pocket wall and the number of pocket corners, calculate L/N_c , enter the curve and read the $\Delta C/1b$. He would then apply his factory total dollar cost per man-hour and obtain the dollar trade-off cost of avoiding a one-pound weight increase.

The cost saving for the entire part using the larger radius would be obtained by the product of equations A4 and A8 .

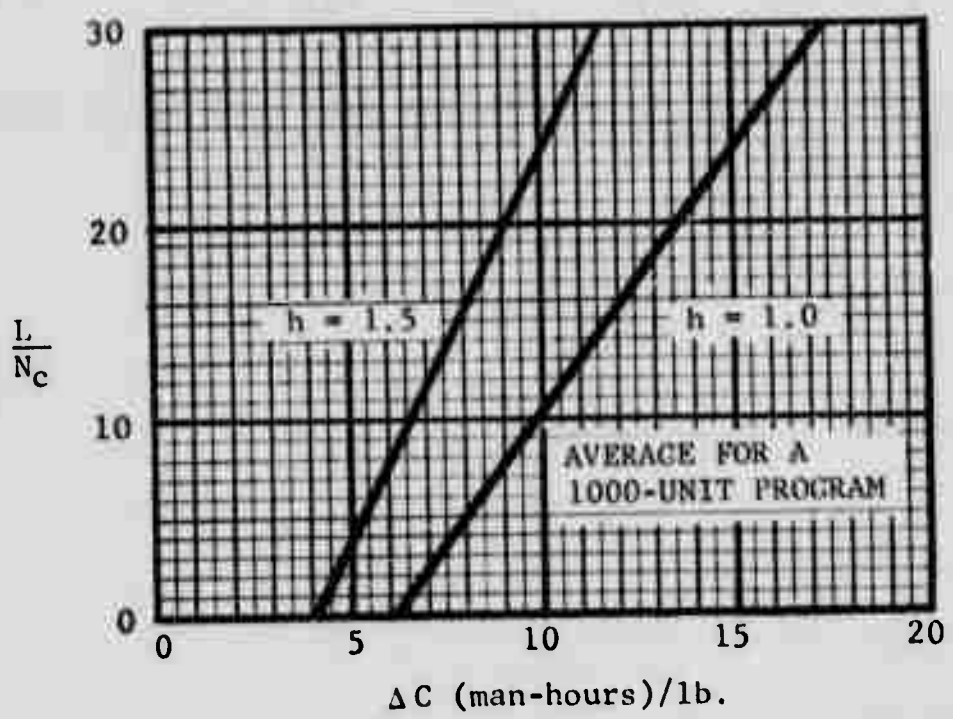

FIGURE A-19 COST OF AVOIDING a 1-LB. WEIGHT INCREASE

5.3.3 Nomenclature

ΔA = difference in plan view area in corner between the two proposed cutters, square inches

f_1 = feed rate of smaller finish cutter, inches per minute

f_2 = feed rate of larger finish cutter, inches per minute

h = height of stiffener or flange, inches

L' = actual distance traveled by centerline of cutter, inches

L = sum of length of pocket walls to be finish machined, measured by the overall pocket dimensions, inches

N_c = number of pocket corners

R_{NC} = cost ratio of NC machine time to NC tape time for a given learning curve and number of units

t_{c1} = time required for smaller cutter to remove material in one corner, minutes

t_{c2} = time required for larger cutter to remove material in one corner, minutes

ρ = density of metal being machined

$\frac{\Delta C}{lb.}$ = cost of avoiding a one-pound weight increase, man-hours per pound

5.3.4 Conclusion

The approach described herein is in use on the F-16 program. Its applicability is, of course, dependent on the NC programming techniques and values used in a given machine shop although those at General Dynamics' Fort Worth Division are typical for a large part of the aerospace industry. Where adaptive control equipment is in use, the cost differences obtained may be low since the one-inch diameter cutter capability is probably not fully exploited by programmers for conventional NC equipment.

A P P E N D I X B

SHOP DIMENSIONAL SURVEY

APPENDIX B
TABLE OF CONTENTS

	<u>Page</u>
1.0 OBTAINING AND RECORDING OF DATA	59
1.1 Type of Part and Manner of Recording	59
1.2 Treatment of Data	59

APPENDIX B
LIST OF ILLUSTRATIONS

<u>Figure</u>		<u>Page</u>
B-1	Typical Survey Data Record	61
B-2	Recommended Relaxation on Drawing Tolerances for Webs and Stiffeners	62
B-3	Web Dimensional Deviation Occurrences vs. Stiffener Spacing for Nominal Web Thickness = 0.040	63
B-4	Web Dimensional Deviation Occurrences vs. Stiffener Spacing for Nominal Web Thickness = 0.045	61
B-5	Web Dimensional Deviation Occurrences vs. Stiffener Spacing for Nominal Web Thickness = 0.055	65
B-6	Web Dimensional Deviation Occurrences vs. Stiffener Spacing for Nominal Web Thickness = 0.064-0.065	66
B-7	Web Dimensional Deviation Occurrences vs. Stiffener Spacing for Nominal Web Thickness = 0.070-0.085	67
B-8	Example of Repeatability in Machining Quality	68

APPENDIX B
LIST OF TABLES

<u>Table</u>		<u>Page</u>
B-I	Work Sheet Tabulation of 12B2703 Survey Results	69
B-II	Work Sheet Tabulation of 12B4192 Survey Results	71
B-III	Work Sheet Tabulation of 12B2740 Survey Results	74
B-IV	Work Sheet Tabulation of 12B4021 Survey Results	75
B-V	Work Sheet Tabulation of 12B4166 Survey Results	78
B-VI	Work Sheet Tabulation of 12B2765 Survey Results	80
B-VII	Factory Survey-Machining Dimensional Accuracy- Milled Aluminum Summary Table for Webs	82
B-VIII	Factory Survey-Machining Dimensional Accuracy- Milled Aluminum Summary Table for Stiffeners/ Webs	83
B-IX	F-111 Machined Parts Surface Roughness	84

APPENDIX B

SHOP DIMENSIONAL SURVEY

Dimensional and surface quality data for various F-111 production parts are presented in the following paragraphs.

1.0 OBTAINING AND RECORDING OF DATA

Over a period of five months, the RTC Quality Assurance team member and F-111 production inspectors surveyed ten major F-111 aluminum NC machined parts. Thirty-six pieces were inspected with up to six pieces for each part number. One thousand seventy thickness measurements were made on webs and 866 measurements on stiffeners and flanges. Five part numbers involving eight pieces were checked for surface roughness early in the survey. With one exception, all measurements were well within current requirements of 125 microinches, AA. Consequently, measurement of roughness was stopped in the interest of economy. Parts were selected that were known not to have unusual features that made machining particularly difficult. It was assumed that design guidelines would reduce the likelihood of unnecessarily difficult designs on future programs. This has generally held true on the F-16 design.

1.1 Type of Part and Manner of Recording

Figure B-1 illustrates one type of part surveyed. Such a sketch was used to record actual and required dimensional and roughness data. Dimensional measurements were usually made on as-machined parts before hand-finishing and on those hand-finished parts known not to have had significant material polished away (which is the usual case). For dimensional measurements, a Parametrics Ultrasonic Gage, Model 5221, was used. A digital readout profilometer with a 0.030 cut-off setting was used for surface roughness measurements.

1.2 Treatment of Data

Data was transferred to data summary work sheets recording date, part and serial number, finish condition, drawing nominal thickness, pocket width, and actual web and stiffener thicknesses. Tables B-I thru B-VI are typical of all data summary work sheets.

The thickness deviation data from the various data summary sheets was then accumulated on Tables B-VII and B-VIII. These tables permitted organization of results in terms of frequency of occurrence versus the magnitude of deviation. These data were accumulated from the highest negative to the highest positive occurrence frequency. Results were plotted in Figure B-2, permitting the recommendation described therein.

Tables B-I thru B-VI present survey data from 6 individual parts (6 drawing numbers), that were used to construct Figures B-4 thru B-7. Figure B-3 was constructed from data obtained from a part (12B2101) with excessive stiffener spacing, invalidating it as a comparison part for normal machining tolerances. These figures are plots of web thickness deviation from nominal dimension vs. pocket width. The figures allow an accurate determination of maximum panel width at any particular web thickness concurrent with dimensional tolerance.

As a measure of the shop's repeatability capability, a large F-111 bulkhead was selected and the envelopes of web thickness deviations for four serialized pieces were superimposed in Figure B-8. These were machined over a four month period with the usual changes in operators and equipment that is common in a large factory.

Surface roughness data is summarized in Table B-IX. It is of interest to note the lack of correlation between roughness and "hand-finished" parts. Labeling a part as having been hand finished often means only that trouble spots are hand finished. Large portions of surface areas may not be touched. A total of 49 measurements were made on as-machined surfaces. The mean roughness was $43.3 \mu\text{AA}$ with a standard deviation of $13.57 \mu\text{AA}$ ($43.3/13.57$) for 47 of these measurements. The other two points reflected a minor cutter malfunction (P/N 12B4166, S/N 2). The combined roughness for all 49 measurements was $50.3/36.9$. On the so-called hand finished surfaces, 22 measurements resulted in roughness of $69.9/19.14$.

DRAWING DIMENSIONAL REQUIREMENTS

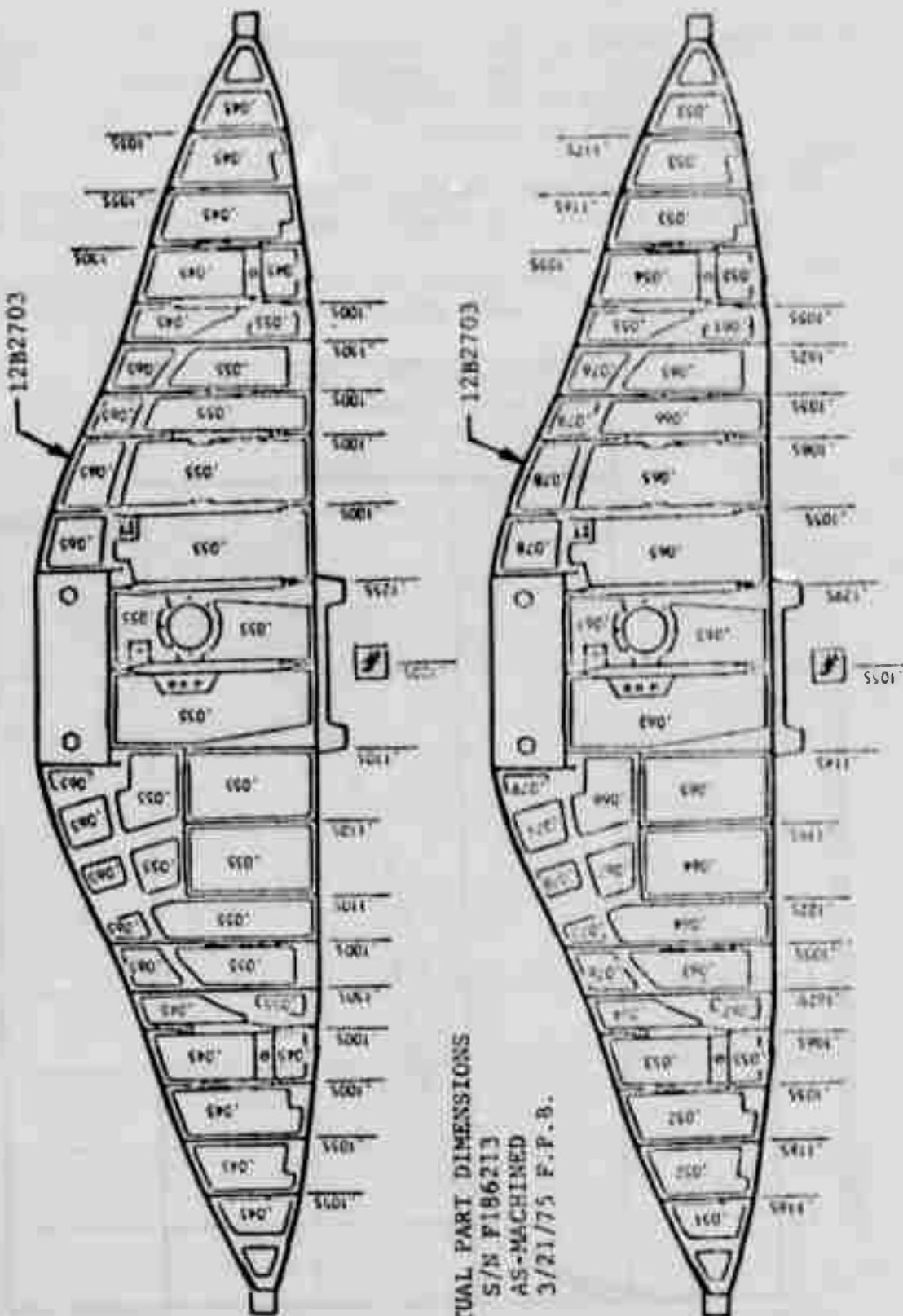

FIGURE B-1 TYPICAL SURVEY DATA RECORD

Data Base:	Number of Measurements - Webs:	1,070
	Number of Measurements - Stiffeners:	866
	Number of Part Numbers:	11
	Number of Pieces:	36

Notes:

- (1) Data was Gathered During November 1974-March 1975 by General Dynamics Inspection on F-111 Production Aluminum Machined Parts
- (2) Analysis was Restricted to Parts with ± 0.010 Tolerance, Excluding Parts with History of Material Warpage or Other Problems

Recommendation: That Standard Drawing Tolerances for Stiffeners and Flanges be Relaxed from ± 0.010 to $+0.015, -0.010$

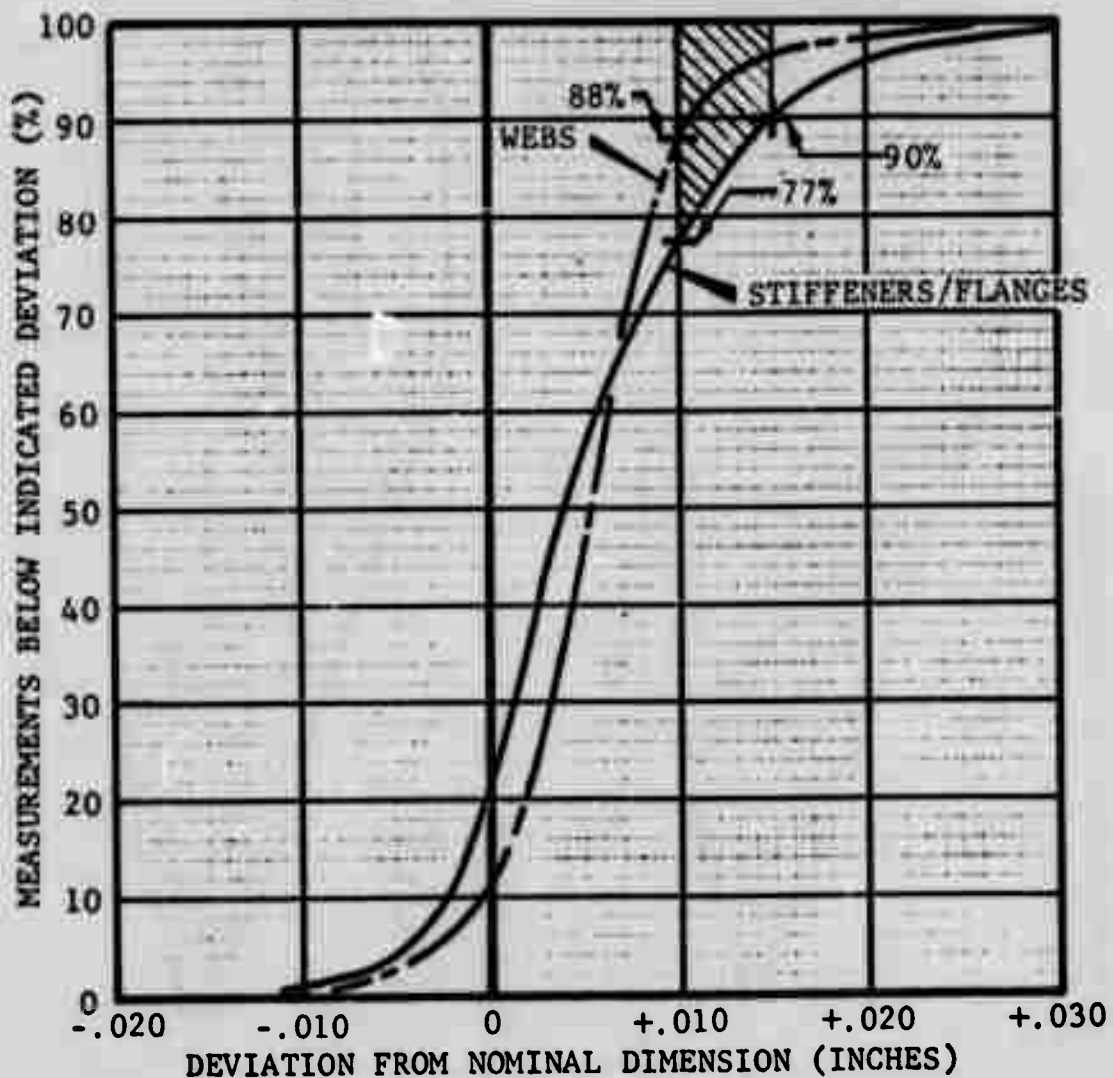

FIGURE B-2 RECOMMENDED RELAXATION ON DRAWING TOLERANCES FOR WEB AND STIFFENERS

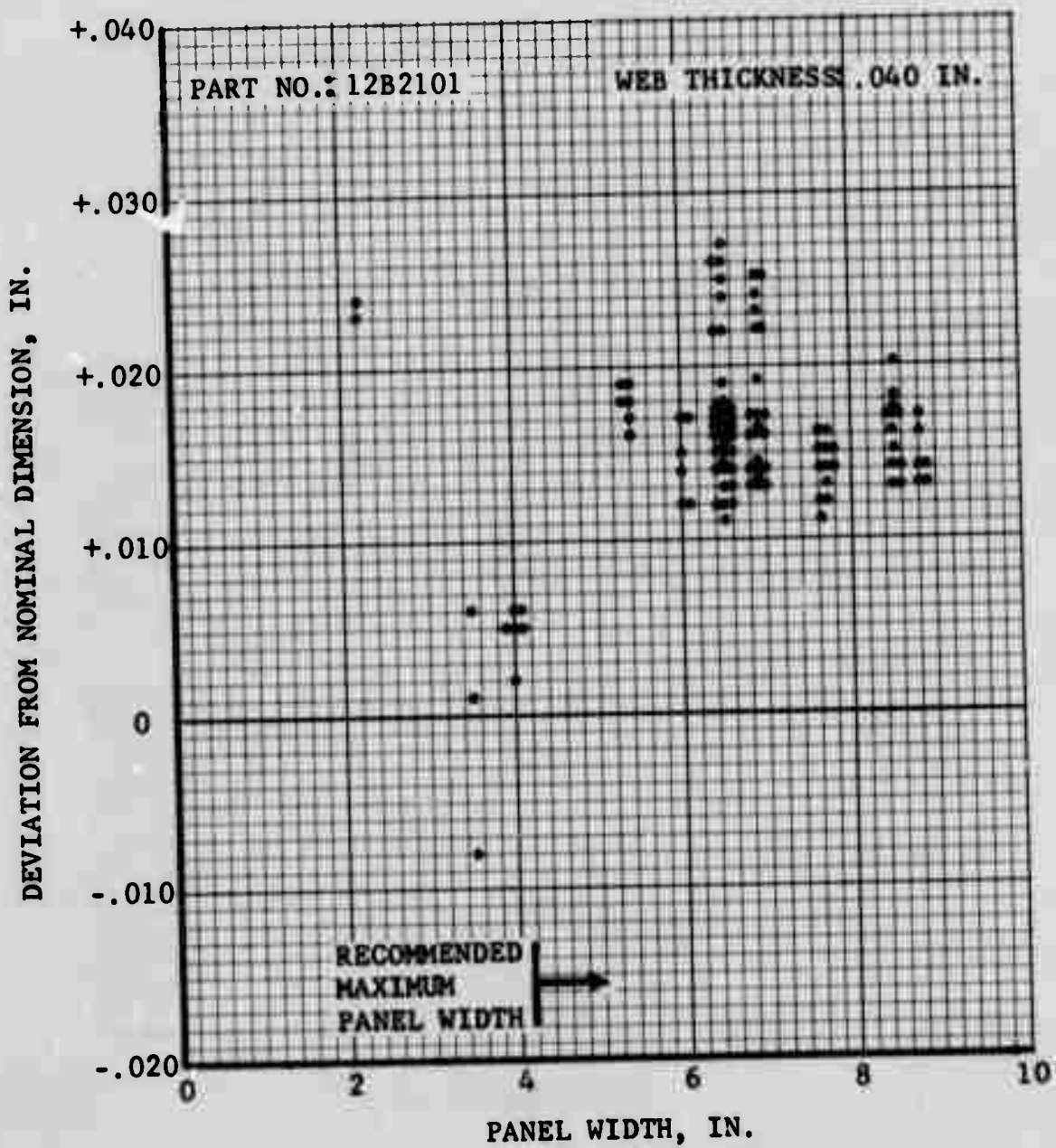

FIGURE B-3 WEB DIMENSIONAL DEVIATION OCCURRENCES VS. STIFFENER SPACING FOR NOMINAL WEB THICKNESS = 0.040

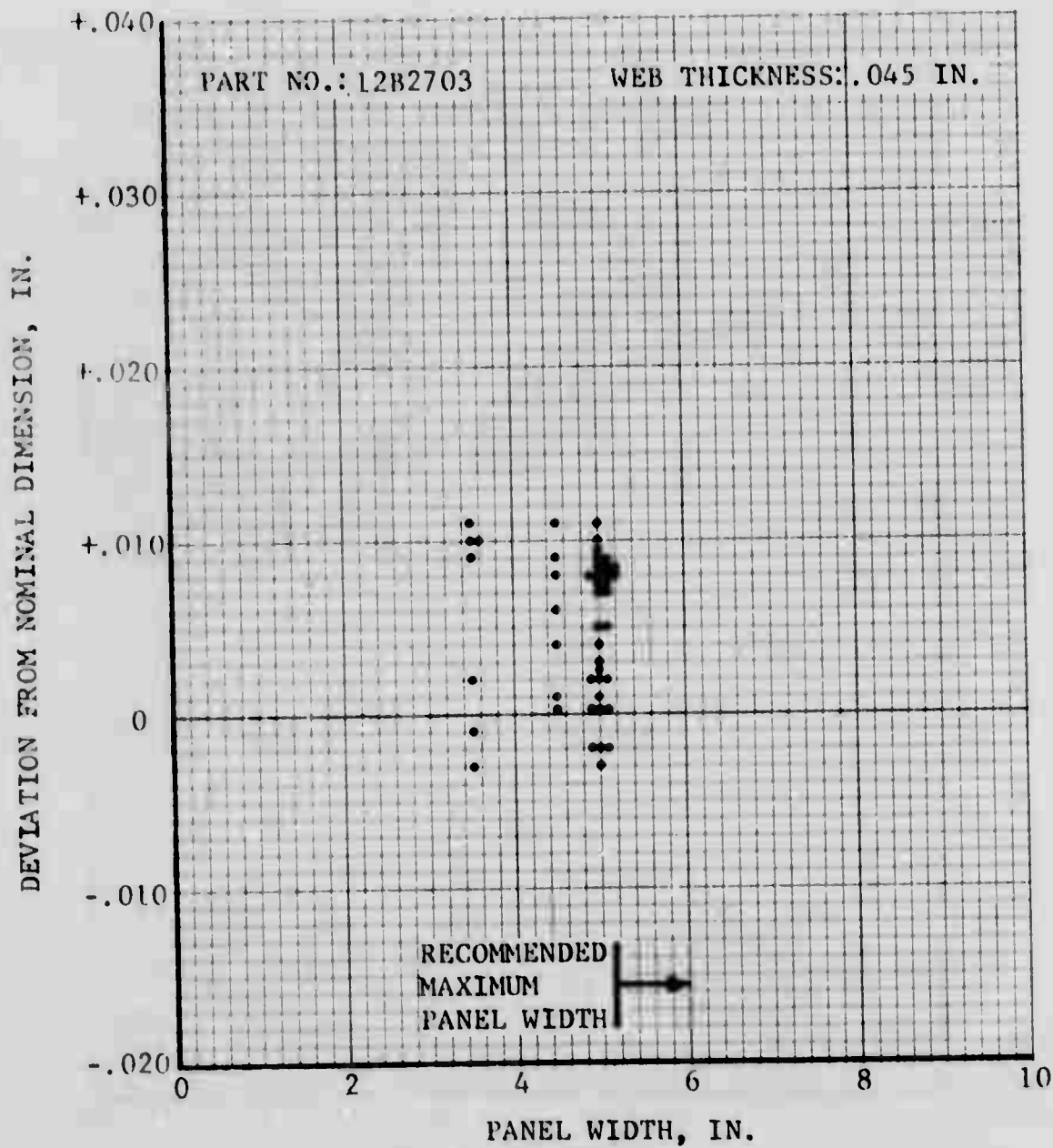

FIGURE B-4 WEB DIMENSIONAL DEVIATION OCCURRENCES VS. STIFFENER SPACING FOR NOMINAL WEB THICKNESS = 0.045

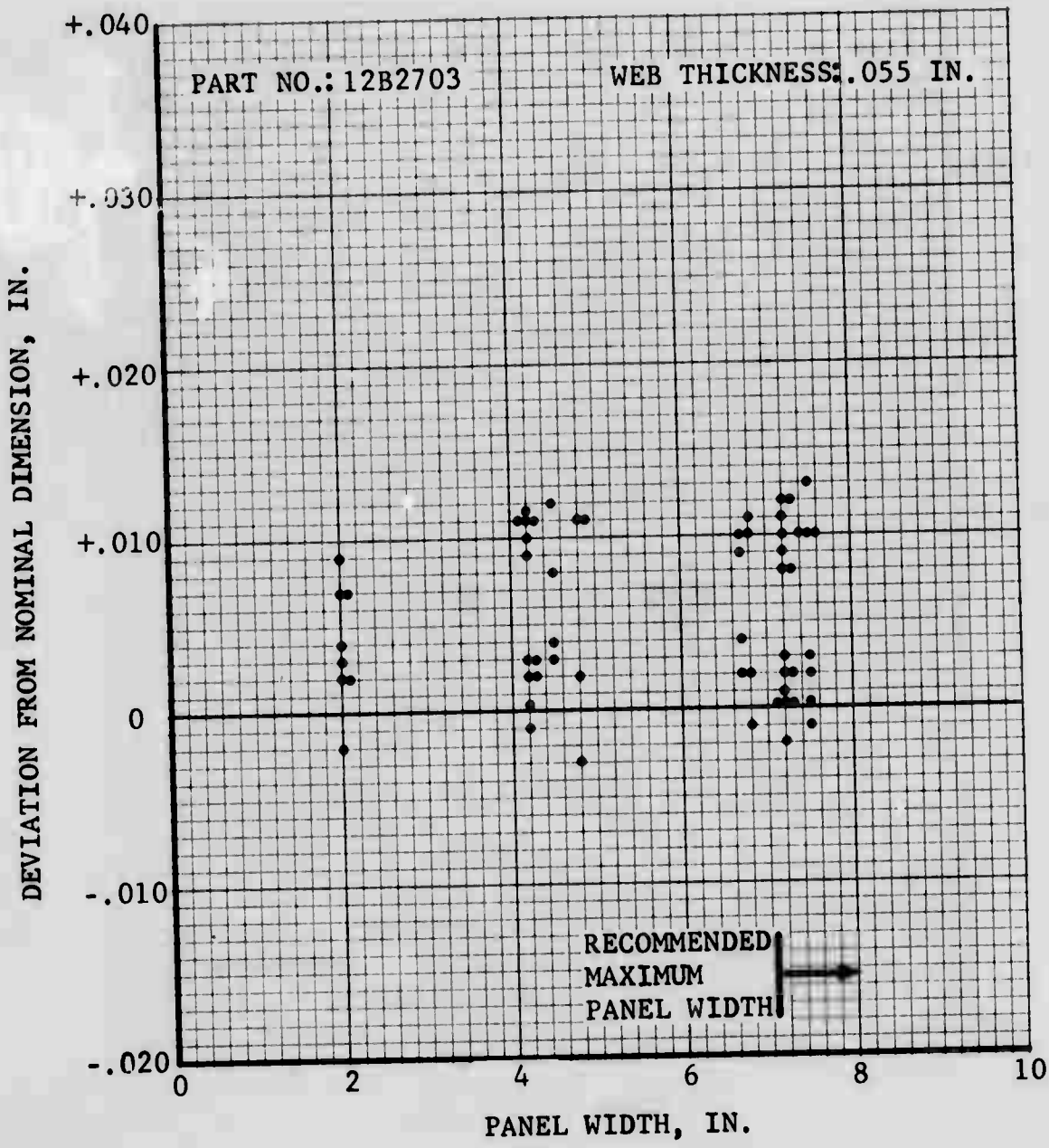

FIGURE B-5 WEB DIMENSIONAL DEVIATION OCCURRENCES VS. STIFFENER SPACING FOR NOMINAL WEB THICKNESS = 0.055

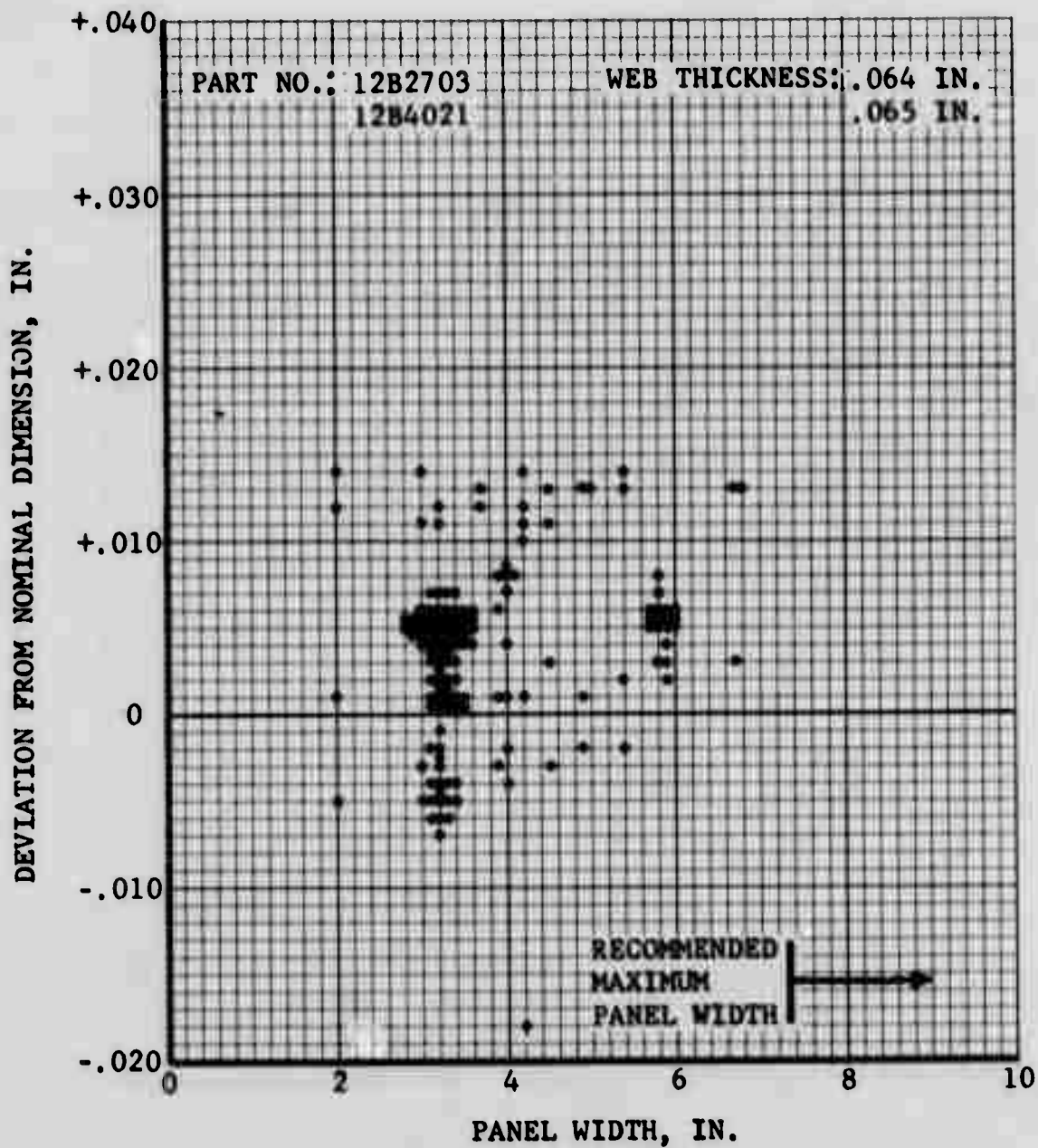

FIGURE B-6 WEB DIMENSIONAL DEVIATION OCCURRENCES VS. STIFFENER SPACING FOR NOMINAL WEB THICKNESS = 0.064 - 0.065

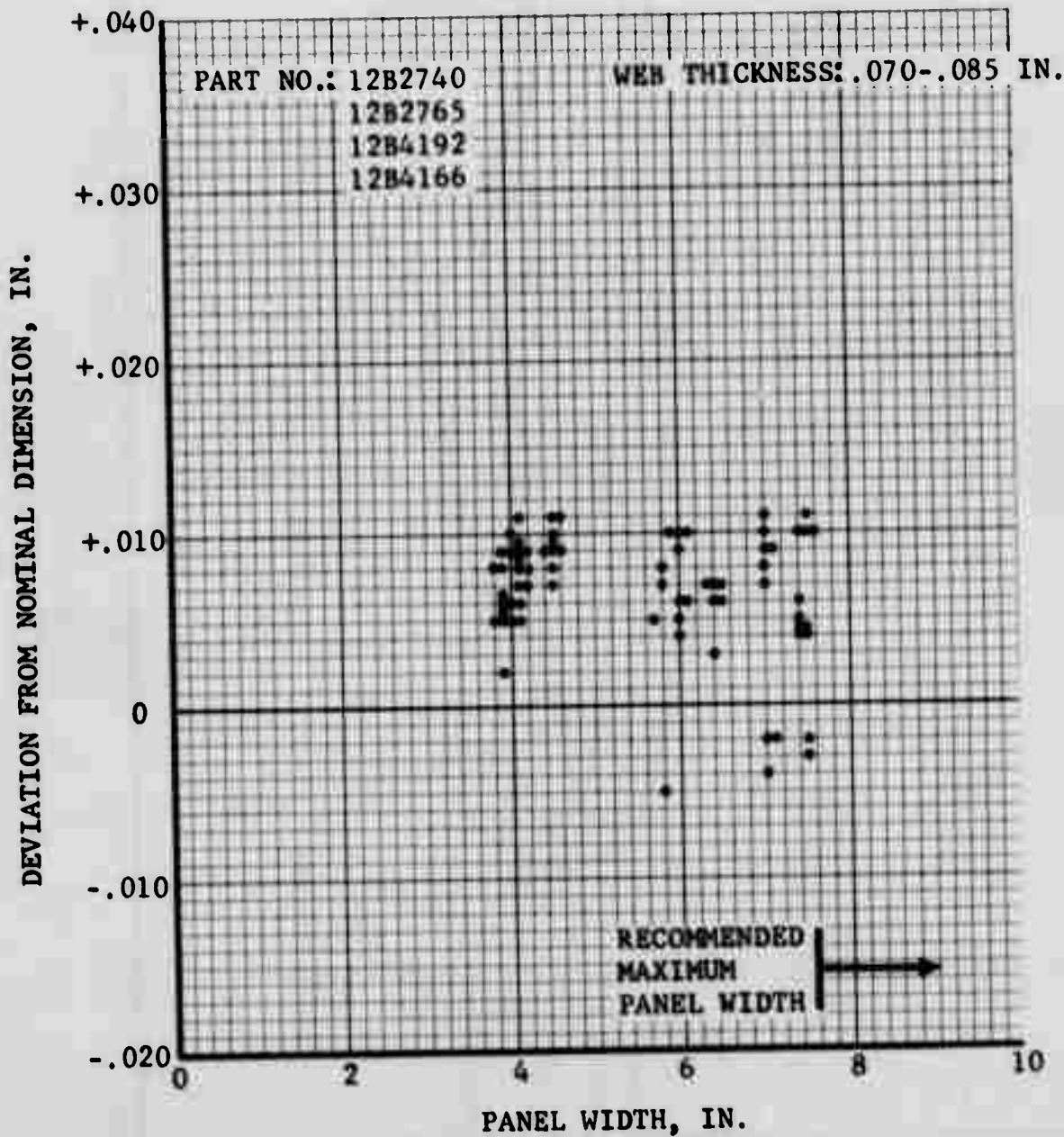

FIGURE B-7 WEB DIMENSIONAL DEVIATION OCCURRENCES VS. STIFFENER SPACING FOR NOMINAL WEB THICKNESS = 0.070 - 0.085

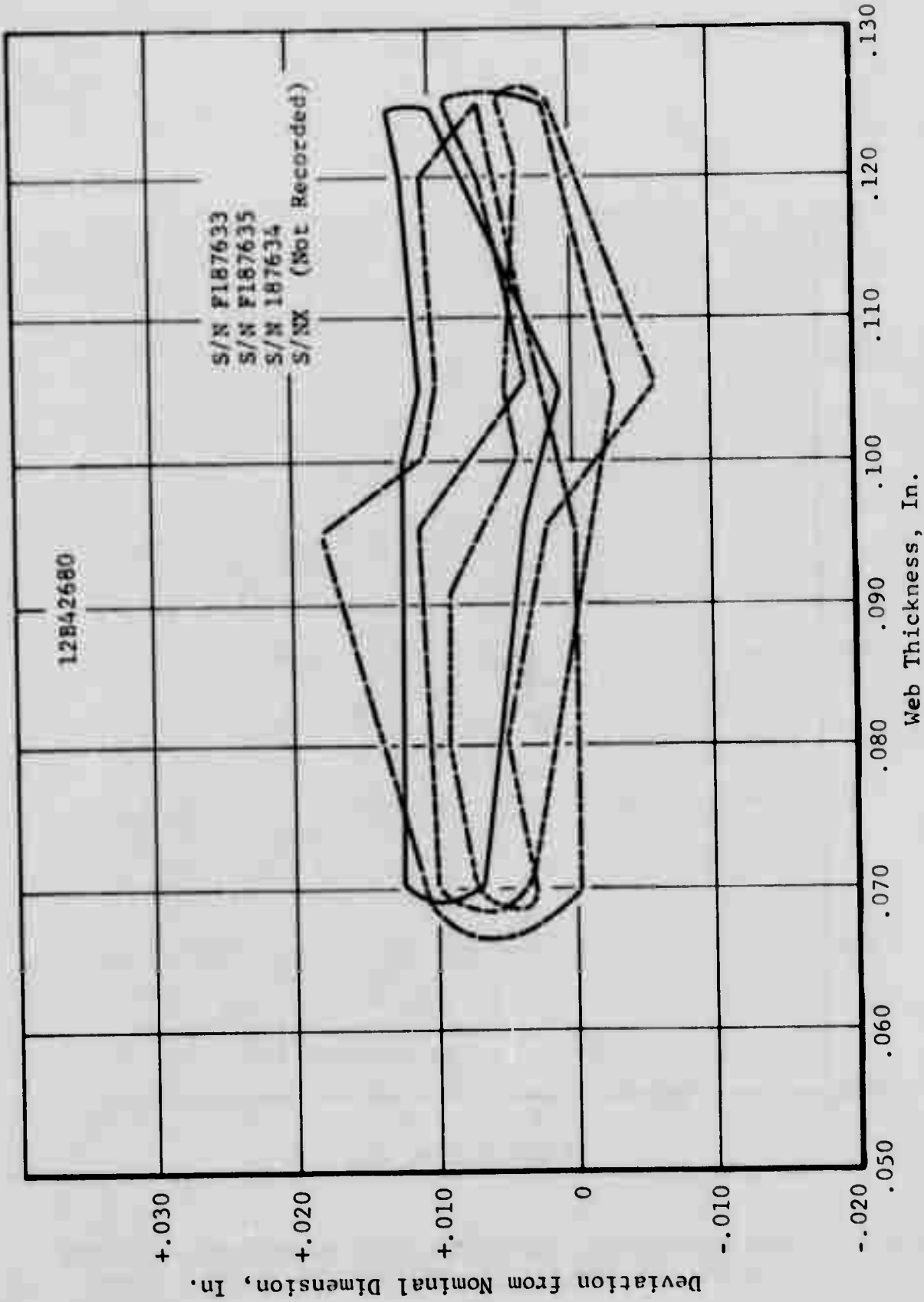

FIGURE B-8 EXAMPLE OF REPEATABILITY IN MACHINING QUALITY

TABLE B-1 WORK SHEET TABULATION OF 12B2703 SURVEY RESULTS

DWG. NO. 12B2703-83

HAND-FINISHED

DATE 4/15/75

AS-MACHINED

#	WERS						STIFFENERS/FLANGES				
	DWG t	POCKET WIDTH	S/N F193900 DATE 3/21/75		S/N F186213 DATE 3/21/75		DWG t	S/N F193900 DATE 3/21/75		S/N F186213 DATE 3/21/75	
			ACTUAL t	Δt	ACTUAL t	Δt		ACTUAL t	Δt	ACTUAL t	Δt
1	.045	4.5	.056	.011	.051	.006	.105	.117	.012	.116	.011
2	.045	5	.054	.009	.052	.007	.105	.117	.012	.116	.011
3	.045	5	.055	.010	.052	.007	.100	.101	.001	.105	.005
4	.045	5	.056	.011	.053	.008	.100	.101	.001	.106	.006
5	.045	5	.053	.008	.053	.008	.150	.163	.013	.162	.012
6	.045	3.5	.056	.011	.054	.009	.100	.102	.002	.105	.005
7	.055	2	.053	.002	.062	.007	.110	.124	.014	.122	.012
8	.065	4.5	.078	.013	.076	.011	.110	.122	.012	.119	.009
9	.055	4.5	.067	.012	.063	.008	.110	.110	0	.114	.004
10	.065	3	.079	.014	.077	.011	.100	.102	.002	.105	.005
11	.055	4.2	.066	.011	.064	.009	.125	.126	.001	.129	.004
12	.065	6.7	.078	.013	.078	.013	.100	.108	.008	.105	.005
13	.055	7.2	.067	.012	.067	.012	.100	.103	.003	.106	.006
14	.055	6.7	.065	.010	.064	.009	.100	.101	.001	.105	.005
15	.065	4.2	.077	.012	.079	.014	.150	.164	.014	.162	.012
16	.055	4.8	.066	.011	.066	.011	.100	.101	.001	.105	.005
17	.055	7.5	.065	.010	.065	.010	.100	.101	.001	.105	.005
18	.065	2.0	.077	.012	.079	.014	.105	.116	.011	.116	.011
19	.055	7.2	.064	.009	.063	.008	.105	.118	.013	.117	.012
20	.055	7.2	.066	.011	.061	.006					
21	.055	7.2	.065	.010	.063	.008					
22	.065	5.4	.079	.014	.078	.013					
23	.055	7.5	.068	.013	.065	.010					
24	.065	4.9	.078	.013	.078	.013					
25	.055	6.8	.066	.011	.065	.010					
26	.065	3.7	.077	.012	.078	.013					
27	.055	4.2	.066	.011	.066	.011					
28	.065	4.2	.076	.011	.076	.010					
29	.055	4.2	.066	.011	.065	.010					
30	.045	3.5	.055	.010	.055	.010					
31	.055	2	.064	.009	.062	.007					
32	.045	5	.053	.008	.054	.009					
33	.045	5	.053	.008	.053	.008					
34	.045	5	.053	.008	.053	.008					
35	.045	5	.054	.009	.053	.008					
36	.045	4.8	.054	.009	.053	.008					

TABLE B-I CONTINUED

DWG NO. 12B2703 -83

HAND-FINISHED

DATE 4/22/75

AS-MACHINED

#	WEBS						STIFFENERS/FIANGES				
	DWG t	POCKET WIDTH	S/N #1 DATE 11/4/74		S/N #2 DATE 11/4/74		DWG t	S/N #1 DATE 11/4/74		S/N #2 DATE 11/4/74	
			ACTUAL t	Δ t	ACTUAL t	Δ t		ACTUAL t	Δ t	ACTUAL t	Δ t
1	.045	4.5	.049	.004	.045	.000	.105	.116	.011	.115	.010
2	.045	5.0	.048	.003	.047	.002	.105	.118	.013	.112	.007
3	.045	5.0	.050	.005	.047	.002	.100	.098	-.002	.097	-.003
4	.045	5.0	.047	.002	.046	.001	.100	.098	-.002	.102	.002
5	.045	5.0	.050	.005	.049	.004	.150	.162	.012	.162	.012
6	.045	3.5	.047	.002	.044	-.001	.100	.102	.002	.099	-.001
7	.055	2.0	.059	.004	.057	.002	.110	.118	.008	.116	.006
8	.055	4.5	.059	.004	.058	.003	.110	.123	.013	.119	.009
9	.055	4.5	.058	.003	.057	.002	.110	.119	.009	.118	.008
10	.065	3.0	.068	.003	.062	-.003	.110	.115	.004	.114	.004
11	.055	4.2	.058	.003	.053	-.002	.100	.099	-.001	.101	.001
12	.055	6.7	.059	.004	.057	.002	.125	.123	-.002	.124	-.001
13	.065	7.2	.068	.003	.062	-.003	.100	.100	.000	.099	-.001
14	.055	6.7	.057	.002	.052	-.003	.100	.100	.000	.100	.000
15	.055	4.2	.058	.003	.055	.000	.100	.098	-.002	.101	.001
16	.055	4.8	.056	.001	.055	.000	.150	.161	.011	.159	.009
17	.055	7.5	.055	.000	.052	-.003	.100	.097	-.003	.099	-.001
18	.055	2.0	.057	.002	.057	.002	.110	.101	-.009	.102	-.008
19	.065	7.2	.066	.001	.060	-.005	.105	.113	.008	.112	.007
20	.055	7.2	.057	.002	.055	.000	.105	.119	.014	.115	.010
21	.065	7.2	.066	.001	.047	-.018					
22	.055	5.4	.057	.002	.054	-.001					
23	.065	7.5	.067	.002	.063	-.002					
24	.055	4.9	.058	.003	.054	-.001					
25	.065	6.8	.066	.001	.063	-.002					
26	.055	3.7	.057	.002	.054	-.001					
27	.055	4.2	.057	.002	.055	.000					
28	.045	4.2	.045	.000	.042	-.003					
29	.045	4.2	.048	.003	.045	.000					
30	.045	3.5	.045	.000	.043	-.002					
31	.045	2.0	.042	-.003	.043	-.002					
32	.045	5.0	.046	.001	.043	-.002					
33											
34											
35											
36											

TABLE B-II WORK SHEET TABULATION OF 12B4192 SURVEY RESULTS

DWG NO. 12B4192-17

HAND-FINISHED

DATE 4/14/75

AS-MACHINED

#	WERS						STIFFENERS/FLANGES					
	DWG t	POCKET WIDTH	S/N #1 DATE 3/26/75		S/N #2 DATE 3/26/75		DWG t	S/N #1 DATE 3/26/75		S/N #2 DATE 3/26/75		
			ACTUAL t	Δt	ACTUAL t	Δt		ACTUAL t	Δt	ACTUAL t	Δt	
1	.150	1.7	.157	.007	.156	.006	S.125	.124	-.001	.130	.005	
2	.150	2.3	--	--	.156	.006	.125	.129	.004	.137	.012	
3	.100	4.7	.108	.008	.108	.008	.110	.115	.005	.123	.013	
4	.100	1.7	.107	.007	.106	.006	.110	.115	.005	.122	.012	
5	.085	4.1	.094	.009	.094	.009	.110	.111	.001	.117	.007	
6	.070	4.5	.080	.010	--	--	.110	.101	-.009	.106	-.104	
7	.050	4.1	.061	.011	.061	.011	.100	.102	.002	.107	.007	
8	.050	4.1	.061	.011	.061	.011	.100	.102	.002	.109	.009	
9	.150		.161	.011	.160	.010	.100	.100	.000	.112	.012	
10	.050	4.1	.061	.011	.060	.010	.100	.099	-.001	.108	.008	
11	.050	4.1	.061	.011	.060	.010	.110	.101	-.009	.108	-.002	
12	.070	4.5	.079	.009	.078	.008	.110	.108	-.002	.115	.005	
13	.085	4.1	.092	.007	.093	.008	.110	.114	.004	.121	.011	
14	.100	1.7	.108	.008	.104	.004	.110	.111	.001	.119	.009	
15	.100	4.7	.108	.008	.107	.007	.125	.130	.005	.143	.018	
16	.150	2.3	--	--	--	--	S.125	.125	.000	.132	.007	
17	.150	1.7	.158	.008	.157	.007	F.160	.166	.006	.172	.012	
18							.160	.167	.007	.169	.009	
19							.150	.152	.002	.153	.003	
20							.150	.154	.004	.158	.008	
21							.135	.138	.003	.146	.011	
22							.135	.134	-.001	.140	.005	
23							.125	.131	.006	.131	.006	
24							.135	.137	.002	.145	.010	
25							.135	.134	-.001	.140	.004	
26							.150	.149	-.001	.154	.004	
27							.150	.149	-.001	.155	.005	
28							.160	.167	.007	.167	.007	
29							.160	.168	.008	.169	.009	
30							F.125	--	--	--	--	
31												
32												
33												
34												
35												
36												

TABLE B-II CONTINUED

DWG NO. 12B4192-17

HAND-FINISHED

DATE 4/15/75

AS-MACHINED

#	WEBS						STIFFENERS/FLANGES				
	DWG t	POCKET WIDTH	S/N #3 DATE 3/26/75		S/N #4 DATE 3/26/75		DWG t	S/N #3 DATE 3/26/75		S/N #4 DATE 3/26/75	
			ACTUAL t	Δt	ACTUAL t	Δt		ACTUAL t	Δt	ACTUAL t	Δt
1	.150	1.7	.157	.007	.155	.005	S.125	.124	-.001	S.131	.006
2	.150	2.3	.158	.008	.159	.009	.125	.129	.004	.139	.014
3	.100	4.7	.108	.008	.110	.010	.110	.111	.001	.125	.015
4	.100	1.7	.109	.009	.111	.011	.110	.111	.001	.123	.013
5	.085	4.1	.094	.009	.096	.011	.110	.111	.001	.117	.007
6	.070	4.5	.081	.011	.081	.011	.110	.101	-.009	.107	-.003
7	.050	4.1	.062	.012	.062	.012	.100	.102	.002	.108	.008
8	.050	4.1	.062	.012	.062	.012	.100	.102	.002	.111	.011
9	.150		.164	.014	.163	.013	.100	.102	.002	.109	.009
10	.050	4.1	.061	.011	.061	.011	.100	.101	.001	.109	.009
11	.050	4.1	.060	.010	.062	.012	.110	.101	-.009	.108	-.002
12	.070	4.5	.079	.009	.079	.009	.110	.108	-.002	.115	.005
13	.085	4.1	.092	.007	.093	.008	.110	.114	.004	.123	.013
14	.100	1.7	.111	.011	.109	.009	.110	.111	.001	.120	.010
15	.100	4.7	.108	.008	.107	.007	.125	.130	.005	.137	.012
16	.150	2.3	.158	.008	.159	.009	S.125	.126	.001	S.133	.008
17	.150	1.7	.158	.008	.158	.008	F.160	.165	.005	F.166	.006
18							.160	.165	.005	.164	.004
19							.150	.148	-.002	.151	.001
20							.150	.148	-.002	.151	.001
21							.135	.134	-.001	.140	.005
22							.135	.134	-.001	.138	.003
23							.125	.129	.004	.126	.001
24							.135	.133	-.002	.139	.004
25							.135	.134	-.001	.139	.004
26							.150	.148	-.002	.154	.004
27							.150	.147	-.003	.153	.003
28							.160	.166	.006	.167	.007
29							.160	.164	.004	.167	.007
30							F.125	--	--	--	--
31											
32											
33											
34											
35											
36											

TABLE B-11 CONTINUED

DWG NO. 12B4192-17

HAND-FINISHED

DATE 4/15/75

AS-MACHINED

#	WEBS				STIFFENERS/FIANGES			
	DWG t	POCKET WIDTH	S/N #5 DATE <u>3/26/75</u> ACTUAL t	Δt	DWG t	S/N #5 DATE <u>3/26/75</u> ACTUAL t	Δt	
1	.150	1.7	.157	.007	S.125	.124	-.001	
2	.150	2.3	.157	.007	.125	.133	.008	
3	.100	4.7	.107	.007	.110	.113	.003	
4	.100	1.7	.110	.010	.110	.114	.004	
5	.085	4.1	.093	.008	.110	.111	.001	
6	.070	4.5	.079	.009	.110	.101	-.009	
7	.050	4.1	.060	.010	.100	.102	.002	
8	.050	4.1	.060	.010	.100	.102	.002	
9	.150		.162	.012	.100	.104	.004	
10	.050	4.1	.059	.009	.100	.101	.001	
11	.050	4.1	.059	.009	.110	.101	-.009	
12	.070	4.5	.077	.007	.110	.108	-.002	
13	.085	4.1	.091	.006	.110	.113	.003	
14	.100	1.7	.106	.006	.110	.110	.000	
15	.100	4.7	.106	.006	.125	.136	.011	
16	.150	2.3	.157	.007	S.125	.126	.001	
17	.150	1.7	.156	.006	F.160	.169	.009	
18					.160	.169	.009	
19					.150	.153	.008	
20					.150	.154	.004	
21					.135	.137	.002	
22					.135	.134	-.001	
23					.125	.138	.013	
24					.135	.137	.002	
25					.135	.134	-.001	
26					.150	.150	.000	
27					.150	.150	.000	
28					.160	.167	.007	
29					.160	.165	.005	
30					F.125	--	--	
31								
32								
33								
34								
35								
36								

TABLE B-III WORK SHEET TABULATION OF 12B2740 SURVEY RESULTS

DWG NO. 12B2740

HAND-FINISHED

DATE 4/22/75

AS-MACHINED

#	WEBS						STIFFENERS/FLANGES					
	DWG t	POCKET WIDTH	S/N #1		S/N #2		DWG t	S/N #1		S/N #2		
			DATE	DATE	DATE	DATE		ACTUAL t	Δt	ACTUAL t	Δt	
			DATE	DATE	DATE	DATE	ACTUAL t <td>Δt</td> <td>ACTUAL t <td>Δt</td> <td>ACTUAL t <td>Δt</td> </td></td>	Δt	ACTUAL t <td>Δt</td> <td>ACTUAL t <td>Δt</td> </td>	Δt	ACTUAL t <td>Δt</td>	Δt
			11/4/74	11/4/74	11/4/74	11/4/74						
1	.040	3.8	.041	.001	--	--	.100	--	--	--	--	--
2	.050	3.1	.055	.005	--	--	--	--	--	--	--	--
3	.160	1.9	.163	.003	--	--	.100	.107	.007	.104	.004	.004
4	.120	5.0	.128	.008	.122	.002	.100	.103	.003	.103	.003	.003
5	.100	5.0	.105	.005	.098	-.002	.100	.108	.008	.103	.003	.003
6	.080	4.2	.090	.010	.085	.005	--	--	--	--	--	--
7	.100	4.2	.107	.007	.100	.000	.130	.134	.004	.137	.007	.007
8	.080	6.5	.090	.010	.085	.005	.130	.134	.004	.137	.007	.007
9	.160	6.5	.108	.008	.100	.000	--	--	--	--	--	--
10	.070	6.3	.080	.010	.074	.004	.110	.104	-.006	.108	-.002	-.002
11	.070	6.3	--	--	.075	.005	.150	.159	.009	.161	.011	.011
12	.050	8.9	.059	.009	.055	.005	.100	.102	.002	.107	.007	.007
13	.100	2.6	.111	.011	.104	.004	.150	.135	-.015	--	--	--
14	.050	6.3	.059	.009	.056	.006	.130	.136	.006	.140	.010	.010
15	--	--	--	--	--	--	.150	.163	.013	--	--	--
16	.050	5.2	.059	.009	.057	.007	--	--	--	--	--	--
17	.050	6.3	.060	.010	.057	.007	.100	.102	.002	.108	.008	.008
18	.100	4.7	.111	.011	.108	.008	.100	.100	.000	.109	.009	.009
19	.100	4.7	--	--	.107	.007	.100	.103	.003	--	--	--
20	--	--	--	--	--	--	--	--	--	--	--	--
21	.050	5.2	.061	.011	.055	.005	--	--	--	--	--	--
22	.050	6.3	.059	.009	.056	.006	.100	--	--	.112	.012	.012
23	--	--	--	--	--	--	.110	.110	.000	.096	-.004	-.004
24	.050	8.9	.060	.010	.055	.005	.150	.160	.010	.152	.002	.002
25	.070	6.3	.079	.009	.076	.006	--	--	--	--	--	--
26	.080	6.5	.090	.010	.086	.006	--	--	--	--	--	--
27	.100	6.5	.105	.005	--	--	--	--	--	--	--	--
28	.080	4.2	.089	.009	.085	.005	--	--	--	--	--	--
29	.100	4.2	.107	.007	--	--	--	--	--	--	--	--
30	.120	5.0	.130	.010	.116	-.004	--	--	--	--	--	--
31	.100	5.0	.101	.001	--	--	--	--	--	--	--	--
32	.160	1.9	.166	.006	--	--	--	--	--	--	--	--
33	.050	3.1	.056	.006	.051	.001	--	--	--	--	--	--
34	.040	3.8	.046	.006	.032	-.008	--	--	--	--	--	--
35												
36												

TABLE B-IV WORK SHEET TABULATION OF 12B4021 SURVEY RESULTS

DWG NO. 12B4021-103

HAND-FINISHED

DATE 6/15/76

AS-MACHINED

#	WEBS						STIFFENERS/FIANGES				
	DWG t	POCKET WIDTH	S/N F190888 DATE 11/21/74		S/N F178237 DATE 11/21/74		DWG t	S/N F190888 DATE 11/21/74		S/N F178237 DATE 11/21/74	
			ACTUAL t	Δ t	ACTUAL t	Δ t		ACTUAL t	Δ t	ACTUAL t	Δ t
1	.064		.069	.005	.073	.009	.150	.146	-.004	.151	.001
2	.064		--	--	--	--	.150	.146	-.004	.152	.002
3	.064		.069	.005	.068	.004	.175	--	--	.175	.000
4	.064		--	--	.070	.006	.175	--	--	.176	.001
5	.064	3.2	.068	.004	.068	.004	.175	.171	-.004	.177	.002
6	.064	3.2	.068	.004	.069	.005	.175	--	--	.177	.002
7	.064	3.2	.068	.004	.068	.004	.175	.177	.002	.176	.001
8	.064	3.2	.067	.003	.069	.005	.175	--	--	.177	.002
9	.064	3.2	.069	.005	.068	.004	.175	.171	-.004	.177	.002
10	.064	3.2	.067	.003	.069	.005	.175	--	--	.178	.003
11	.064	3.2	.067	.003	.068	.004	.175	.176	.001	.176	.001
12	.064	3.2	.068	.004	--	--	.175	--	--	.177	.002
13	.064	3.2	--	--	.069	.005	.175	.169	-.006	.181	.006
14	.064	3.2	.089	.025	.091	.027	.175	--	--	.178	.003
15	.064	3.2	.089	.025	.090	.026	.175	--	--	--	--
16	.064		.090	.026	.090	.026	.175	--	--	--	--
17	.064		--	--	--	--	.175	.172	-.003	.180	.005
18	.064		--	--	.090	.026	.175	.179	.004	.178	.003
19	.064	3.2	.069	.005	.068	.004	.175	.170	-.005	.178	.003
20	.064	3.2	.069	.005	.069	.005	.175	.171	-.004	.179	.004
21	.064	3.2	.068	.004	.069	.005	.175	.171	-.004	.178	.003
22	.064	3.2	.068	.004	.069	.005	.175	.170	-.005	.178	.003
23	.064	3.2	.122	.058	.123	.059	.175	.172	-.003	.179	.004
24	.064	3.2	.068	.004	.069	.005	.175	.172	-.003	.179	.004
25	.064	3.2	.069	.005	.069	.005	.175	.169	-.006	.178	.003
26	.064	3.2	.068	.004	.070	.006	.175	.171	-.004	.178	.003
27	.064	3.2	.069	.005	.070	.006	.175	.171	-.004	.178	.003
28	.064	3.2	.069	.005	.069	.005	.175	.178	.003	.178	.003
29	.064	3.2	.070	.006	.070	.006	.175	.169	-.006	.178	.003
30	.064	3.2	.069	.005	.070	.006	.175	.174	-.001	.178	.003
31	.064	3.2	.071	.007	.071	.007	.175	.175	.000	.178	.003
32	.064	3.2	.070	.006	.071	.007	.175	.177	.002	.178	.003
33	.064	4.0	.072	.008	.072	.008	.175	.179	.004	.173	-.002
34	.064	4.0	.071	.007	.072	.008	.175	.173	-.002	.178	.003
35	.071	3.9	.077	.006	.079	.008					
36	.064	3.9	.072	.006	.072	.008					

TABLE B-IV CONTINUED

DWG NO. 12B4021-103

HAND-FINISHED

DATE 4/15/75

AS-MACHINED

#	WEBS						STIFFENERS/FIANGES				
	DWG t	POCKET WIDTH	S/N F197361 DATE 4/8/75		S/N F190887 DATE 4/8/75		DWG t	S/N F197361 DATE 4/8/75		S/N F190887 DATE 4/8/75	
			ACTUAL t	Δ t	ACTUAL t	Δ t		ACTUAL t	Δ t	ACTUAL t	Δ t
1	.064		.078	.014	.070	.006	.150	.160	.010	.161	.011
2	.064		.071	.007	.067	.003	.150	.158	.008	.160	.010
3	.064		.076	.012	.063	-.001	.175	.195	.020	.192	.018
4	.064		.070	.006	.069	.005	.175	.194	.019	.190	.015
5	.064	3.2	.069	.005	.064	.000	.175	.183	.008	.185	.010
6	.064	3.2	.068	.004	.065	.001	.175	.182	.007	.182	.007
7	.064	3.2	.069	.005	.063	-.001	.175	.181	.006	.178	.003
8	.064	3.2	.067	.003	.064	.000	.175	.179	.004	.178	.003
9	.064	3.2	.068	.004	.067	.003	.175	.181	.006	.182	.007
10	.064	3.2	.067	.003	.065	.001	.175	.177	.002	.177	.002
11	.064	3.2	.075	.011	.060	-.004	.175	.179	.004	.180	.005
12	.064	3.2	.069	.005	.062	-.002	.175	.177	.002	.179	.004
13	.064	3.2	.070	.006	.062	-.002	.175	.179	.004	.174	-.001
14	.064	3.2	.065	.001	.059	-.005	.175	.180	.005	.176	.001
15	.064	3.2	.067	.003	.058	-.006	.175	.177	.002	.177	.002
16	.064		.068	.004	.064	.000	.175	.178	.003	.172	-.003
17	.064		.071	.007	.060	-.004	.175	.180	.005	.180	.005
18	.064		.076	.012	.066	.002	.175	.181	.006	.175	.000
19	.064	3.2	.066	.002	.059	-.005	.175	.179	.004	.179	.004
20	.064	3.2	.066	.002	.059	-.005	.175	.174	-.001	.179	.004
21	.064	3.2	.068	.004	.059	-.005	.175	.178	.003	.179	.004
22	.064	3.2	.065	.001	.058	-.005	.175	.176	.001	.178	.003
23	.064	3.2	.065	.001	.060	-.004	.175	.177	.002	.177	.002
24	.064	3.2	.064	.000	.059	-.005	.175	.176	.001	.175	.000
25	.064	3.2	.065	.001	.059	-.005	.175	.177	.002	.173	-.002
26	.064	3.2	.064	.000	.060	-.004	.175	.173	-.002	.175	.000
27	.064	3.2	.068	.004	.060	-.004	.175	.179	.004	.176	.001
28	.064	3.2	.066	.002	.058	-.006	.175	.187	.012	.184	.009
29	.064	3.2	.071	.007	.057	-.007	.175	.182	.007	.182	.007
30	.064	3.2	.064	.000	.061	-.003	.175	.186	.011	.186	.011
31	.064	3.2	.069	.005	.062	-.002	.175	.183	.008	.179	.004
32	.064	3.2	.065	.001	.062	-.002	.175	.178	.003	.179	.004
33	.064	4.0	.068	.004	.062	-.002	.175	.182	.007	.181	.006
34	.064	4.0	.065	.001	.060	-.004	.175	.178	.003	.179	.004
35	.071	3.9	.077	.006	.076	.005					
36	.064	3.9	.065	.001	.061	-.003					

TABLE B-IV CONTINUED

DWG NO. 1284021-103

HAND-FINISHED

DATE: 4/22/75

AS-MACHINED

#	WEBS				STIFFENERS/FLANGES			
	DWG t	POCKET WIDTH	S/N F178237 DATE 1/7/75		DWG t	S/N F178237 DATE 1/7/75		
			ACTUAL t	Δ t		ACTUAL t	Δ t	
1	.064		.072	.008	.150	.155	.005	
2	.064		.060	.006	.150	.151	.001	
3	.064		.065	.001	.150	.150	.000	
4	.064		.066	.002	.150	.150	.000	
5	.064	3.2	.067	.003	.175	.173	-.002	
6	.064	3.2	.064	.000	.175	.176	.001	
7	.064	3.2	.065	.001	.175	.175	.000	
8	.064	3.2	.066	.002	.175	.175	.000	
9	.064	3.2	.064	.000	.175	.175	.000	
10	.064	3.2	.066	.002	.175	.174	-.001	
11	.064	3.2	.064	.000	.175	.174	-.001	
12	.064	3.2	.065	.001	.175	.175	.000	
13	.085	3.2	.086	.001	.175	.173	-.002	
14	.085	3.2	.087	.002	.175	.175	.000	
15	.085	3.2	.087	.002	.175	.174	-.001	
16	.085		.086	.001	.175	.175	.000	
17	.064		.065	.001	.175	.175	.000	
18	.064		.065	.001	.175	.174	-.001	
19	.064	3.2	.064	.000	.175	.175	.000	
20	.064	3.2	.064	.000	.175	.174	-.001	
21	.064	3.2	.065	.001	.175	.174	-.001	
22	.064	3.2	.065	.001	.175	.174	-.001	
23	.064	3.2	.065	.001	.175	.175	.000	
24	.064	3.2	.066	.002	.175	.175	.000	
25	.064	3.2	.065	.001	.175	.174	-.001	
26	.064	3.2	.065	.001	.175	.176	.001	
27	.064	3.2	.066	.002	.175	.175	.000	
28	.064	3.2	.066	.002	.175	.175	.000	
29	.064	3.2	.068	.004	.175	.175	.000	
30	.064	3.2	.065	.001	.175	.176	.001	
31	.064	3.2	.069	.005	.175	.174	-.001	
32	.064	3.2	.069	.005	.175	.175	.000	
33	.071	4.0	.077	.006	.175	.170	-.005	
34	.064	4.0	.070	.006	.175	.175	.000	
35	.120	3.9	.125	.005				
36	.064	3.9	.066	.002				

TABLE B-V WORK SHEET TABULATION OF 12B4166 SURVEY RESULTS

DWC NO. 12B4166

HAND-FINISHED

DATE 4/16/75

AS-MACHINED

#	WEBS						STIFFENERS/FLANGES				
	DWC t	POCKET WIDTH	S/N #1 DATE 11/25/74		S/N #2 DATE 11/25/74		DWC t	S/N #1 DATE 11/25/74		S/N #2 DATE 11/25/74	
			ACTUAL t	Δt	ACTUAL t	Δt		ACTUAL t	Δt	ACTUAL t	Δt
1	.125		.134	.009	.131	.006	.100	.103	.003	.104	.004
2	.125		.133	.008	.131	.006	.100	.100	.000	.102	.002
3	.070		.078	.008	.077	.007	.125	.125	.000	.125	.000
4	.125		.135	.010	.134	.009	.125	.127	.002	.127	.002
5	.125		.131	.006	.131	.006	.125	.121	-.004	.121	-.004
6	.125		.131	.006	.131	.006	.100	.104	.004	.104	.004
7	.070	7.0	.079	.009	.079	.009	.150	.152	.002	.150	.000
8	.125		.136	.011	.136	.011	.125	.130	.005	.130	.005
9	.125		.138	.013	.160	.035	.125	.131	.006	.130	.005
10	.070	7.5	.080	.010	.080	.010	.125	.130	.005	.131	.006
11	.070	7.0	.081	.011	.080	.010	.100	.098	-.002	.098	-.002
12	.070	7.5	.081	.011	.080	.010	.125	.133	.008	.132	.007
13	.070	7.0	.078	.008	.077	.007	.125	.137	.012	--	--
14	.070	5.8	.078	.008	.077	.007	.100	.098	-.002	.097	-.003
15							.100	.102	.002	.100	.000
16							.125	.140	.015	.137	.012
17											
18											
19											
20											
21											
22											
23											
24											
25											
26											
27											
28											
29											
30											
31											
32											
33											
34											
35											
36											

TABLE B-V CONTINUED

DWG NO. 1284166

HAND-FINISHED

DATE 4/23/75

AS-MACHINED

#	WERS				STIFFENERS/FLANGES			
	DWG t	POCKET WIDTH	S/N F189886 DATE 12/10/74		DWG t	S/N F189886 DATE 12/10/74		
			ACTUAL t	Δt		ACTUAL t	Δt	
1	.125		.124	-.001		.100	.106	.006
2	.125		.123	-.002		.100	.105	.005
3	.070		--	--		.125	.121	-.004
4	.125		.121	-.004		.125	.126	.001
5	.125		.124	-.001		.125	.127	.002
6	.125		.119	-.006		.100	.105	.005
7	.070	7.0	.068	-.002		.150	.154	.004
8	.125		.126	.001		.125	.137	.012
9	.125		.126	.001		.125	--	--
10	.070	7.5	.067	-.003		.125	.133	.008
11	.070	7.0	.068	-.002		.100	.097	-.003
12	.070	7.5	.068	-.002		.125	.132	.007
13	.070	7.0	.066	-.004		.125	.130	.005
14	.070	5.8	.065	-.005		.100	.100	.000
15						.100	.102	.002
16						.125	.126	.001
17								
18								
19								
20								
21								
22								
23								
24								
25								
26								
27								
28								
29								
30								
31								
32								
33								
34								
35								
36								

TABLE B-VI WORK SHEET TABULATION OF 12B2765 SURVEY RESULTS

DWG. NO 12B2765

HAND-FINISHED

DATE 4/16/75

AS-MACHINED

#	WFBS						STIFFENERS/FLANGES				
	DWG t	POCKET WIDTH	S/N F184619 DATE 11/20/74		S/N F184622 DATE 11/20/74		DWG t	S/N F184619 DATE 11/20/74		S/N F184622 DATE 11/20/74	
			ACTUAL t	Δt	ACTUAL t	Δt		ACTUAL t	Δt	ACTUAL t	Δt
1	.175		--	--	--	--	.100	.107	.007	.102	.002
2	.275		--	--	--	--	.100	.103	.003	.108	.008
3	.300		--	--	--	--	.080	.098	.018	.097	.017
4	.085	7.4	.089	.004	.091	.006	.080	.086	.006	.087	.007
5	.065	4.4	.071	.006	.070	.006	.100	.105	.005	.107	.007
6	.125		.132	.007	.130	.005	.100	.120	.020	.120	.020
7	.065	5.9	.070	.005	.070	.005	.150	.177	.027	.173	.023
8	.065	5.9	.070	.005	.069	.005	.150	.166	.016	.167	.017
9	.065	5.8	.070	.005	.071	.004	.080	.084	.004	.085	.005
10	.075	3.9	.081	.006	.080	.006	.150	.145	-.005	.148	-.002
11	.075	6.4	.082	.007	.081	.005	.150	.150	.000	.150	.000
12	.040	4.0	.046	.006	.045	.006	.100	.094	-.006	.096	-.004
13	.050	9.3	.064	.014	.066	.005	--	--	--	--	--
14	.050	8.0	.066	.016	.066	.016	.100	.106	.006	.106	.006
15	.040	8.8	.056	.016	.053	.016	.080	.104	.024	.087	.007
16	.040	8.8	.058	.018	.053	.013	.080	.074	-.006	.078	-.002
17	.050	9.2	.066	.016	.064	.013	.100	.105	.005	.107	.007
18	.050	8.0	.065	.015	.065	.014	.100	.106	.006	.102	.002
19	.040	4.0	.046	.006	.045	.015					
20	.075	6.4	.082	.007	.081	.005					
21	.075	3.9	.084	.009	.083	.006					
22	.065	5.8	.071	.006	.071	.008					
23	.065	5.9	.072	.007	.070	.006					
24	.065		.072	.007	.068	.005					
25	.125		.133	.008	.133	.003					
26	.065	5.9	.071	.006	.070	.008					
27	.085	7.4	.089	.004	.089	.005					
28	.175		--	--	--	.004					
29	.275		--	--	--						
30	.300		--	--	--						

TABLE B-VI CONTINUED

DWG. NO. 12H2765

HAND-FINISHED

DATE: 4/22/75

AS-MACHINED

#	WEBS				STIFFENERS/FLANGES			
	DWG t	POCKET WIDTH	S/N #1 DATE 3/4/75		DWG t	S/N #1 DATE 3/4/75		
			ACTUAL t	Δt		ACTUAL t	Δt	
1	.175		--	--	.100	.107	.007	
2	.275		--	--	.100	.107	.007	
3	.300		--	--	.080	.089	.009	
4	.085	7.4	.089	.004	.080	.084	.004	
5	.065	4.4	--	--	.100	.104	.004	
6	.125		--	--	.100	.111	.011	
7	.065	5.9	.068	.003	.150	.154	.004	
8	.065	5.9	.067	.002	.150	.158	.008	
9	.065	5.8	.068	.003	.080	.086	.006	
10	.075	3.9	.077	.002	.150	.152	.002	
11	.075	6.4	.078	.003	.150	.158	.008	
12	.040	4.0	.042	.002	.100	.104	.004	
13	.050	9.3	.062	.012	--	--	--	
14	.050	8.0	.064	.014	.100	.104	.004	
15	.040	8.8	.054	.014	.080	.082	.002	
16	.040	8.8	.054	.014	.080	.082	.002	
17	.050	9.2	.066	.016	.100	.108	.008	
18	.050	8.0	.066	.016	.100	.105	.005	
19	.040	4.0	.045	.005				
20	.075	6.4	.082	.007				
21	.075	3.9	.080	.005				
22	.065	5.8	.073	.008				
23	.065	5.9	.070	.005				
24	.065		--	--				
25	.125		--	--				
26	.065	5.9	.070	.005				
27	.085	7.4	.090	.005				
28	.175		--	--				
29	.275		--	--				
30	.300		--	--				

TABLE B-IX F-111 MACHINED PARTS SURFACE ROUGHNESS

P/N	S/N *	Dwg. Web. T (in.)	Heightness (AA)	Dwg. Web. T (in.)	Roughness (AA)
12W902-25	#1 (A-M)	.117	33	.100	38
		.117	45	.130	43
		.117	28	.130	41
		.117	47	.130	47
		.117	41	.110	41
		.100	62	.160	19
	#2 (A-M)	.140	67	.125	55
		.117	21	.100	54
		.117	51	.100	40
		.117	56	.130	44
		.117	49	.130	45
		.117	48	.220	59
		.117	46	.160	25
		.125	37		
12W902-19	F190388 (A-M)	.286	44	.055	50
		.077	33	.365	50
		.050	41	.065	45
12B42680	#1 (A-M)	.095	58	.070	22
		.095	49	.120	53
		.095	42	.095	54
		.095	52	.105	61
		.095	67		
	F187633 (H-F)	.095	63	.070	63
		.095	62	.095	58
		-	56	.095	54
12B4196	#1 (A-M)	.125	9		
		.125	25		
		.125	28		
	#2 (A-M)	.125	221	.125	13 (opp. side)
		.125	210		
12B4021-107	F178237 (H-F)	.064	85	.064	48
		.064	101	.064	70
		.064	84	.064	49
		.064	41	.064	51
		.064	99	.064	107
		.064	86	.085	46
		.064	71	.064	76
		.064	77	.064	87

Results: 49 measurements on As-Machined surfaces
 Mean = 50.3 in AA, standard deviation = 36.9
 22 measurements on Hand-Finished surfaces
 Mean = 69.9 in AA, standard deviation = 19.14

* Where parts were not serialized, pieces were given the numbers shown.

A P P E N D I X C

FATIGUE TEST SPECIMEN DESIGN
AND MANUFACTURING DATA

APPENDIX C

TABLE OF CONTENTS

	<u>Page</u>
1.0 TEST SPECIMEN DESIGN	89
1.1 Task I - I-Beams	89
1.2 Task II - Aircraft Component Tests	89
2.0 MANUFACTURING DATA	90
2.1 Machining Procedures	90
2.2 Hand Finishing	91
2.3 Surface Finish Data	91

APPENDIX C

LIST OF ILLUSTRATIONS

<u>Figure</u>		<u>Page</u>
C-1	Aluminum I-Beam Development Test Specimen, P/N 622-001	92
C-2	Titanium I-Beam Development Test Specimen, P/N 622-002	93
C-3	F-111 Wing Rear Spar-Inbd-Verification Test Specimen, P/N 622-003	94
C-4	F-111 Wing Rear Spar-Outbd-Verification Test Specimen, P/N 622-011	95
C-5	YF-16 Bulkhead Verification Test Specimen, P/N 622-005	96
C-6	Cutting Tool Specification-Standard 2 Flute End Mills for Aluminum	97
C-7	Cutting Tool Specification-High Helix Aluminum Cutting End Mills	98
C-8	Cutting Tool Specification-4, 6, & 8 Flute End Mills	100

APPENDIX C

LIST OF TABLES

<u>Table</u>		<u>Page</u>
C-I	Verification Test Program Summary	102
C-II	Giddings & Lewis (8 x 30) 3-Axis Skin Mill Specifications	103
C-III	Onsrud 4-Axis Mill Specifications	104
C-IV	Giddings & Lewis (8 x 30) 4-Axis Mill Specifications	105
C-V	Sizes and Geometry of End Mills Used to Machine Test Parts	106
C-VI	Summary of Parameters Used in Machining Specimens-End Milling	107
C-VII	I-Beam Test Specimens Surface Finish Data-Aluminum, P/N 622-001	110
C-VIII	I-Beam Test Specimens Surface Finish Data-Titanium, P/N 622-002	113
C-IX	F-111 Wing Rear Spar-Inbd-Surface Finish Data, P/N 622-003	115
C-X	F-111 Wing Rear Spar-Outbd-Surface Finish Data, P/N 622-011	116
C-XI	YF-16 Bulkhead Surface Finish Data, P/N 622-005	117

APPENDIX C

FATIGUE TEST SPECIMEN DESIGN AND MANUFACTURING DATA

Design and manufacturing data for the fatigue test articles used in Phase IV are included in the following paragraphs.

1.0 TEST SPECIMEN DESIGN

Testing involved two different task areas. Task I was aluminum and titanium I-beams used to assess various tolerance relaxations in a structure typical of aircraft. Task II specimens were components of F-111 and YF-16 parts. Table C-I summarizes the test program.

1.1 Task I - I-Beams

The beams have a 30 inch test section with a 12 inch load introduction and transition section at each end. There are six pockets machined from both sides in the test specimen. After machining, half of each beam was hand finished and the other end of the beam was left as machined. Figures C-1 and C-2 show the I-beam configurations.

1.2 Task II - Aircraft Component Tests

These tests included specimens of two sections of the F-111 wing rear spar and a segment of a YF-16 bulkhead. These specimens were used to verify tolerance relaxations on actual aircraft component configurations. The F-111 inboard spar specimen is a 30 inch test section outboard of rear spar station 143.40. There is a 15.12 inch load introduction and transition section at each end of the specimen for a total length of 60.25 inches. The specimen of the outboard section of the F-111 wing rear spar has a 28.18 inch test section starting at rear spar station 211.716 with a 15 inch loading and transition section at each end. The upper portion of the station 479.55 bulkhead on the YF-16 is a titanium two piece back-to-back channel. This titanium section bolted into the rest of the bulkhead, which was aluminum. Because of this, no test load introduction or transition area was necessary. This section of the bulkhead was used as the third

component for this series of tests. In the case of the spars, equal numbers of specimens were left either as-machined or hand-finished. For the bulkheads, half of each channel was hand-finished and half was left as-machined. Figures C-3, C-4 and C-5 illustrate each of the Task II specimens.

2.0 MANUFACTURING DATA

Test specimens were machined by NC machines and hand-finished as described below.

2.1 Machining Procedures

Test components were machined using normal production equipment, programming and machine operators. This procedure was deliberately selected to provide test components that were representative of production aerospace parts with respect to machining processes used to fabricate them. Only sharp cutting tools were used to eliminate additional variables that could be introduced by varying degrees of cutter dullness. Production NC milling machines used to fabricate the test components are maintained to established specifications that are suitable for production requirements. It is recognized that even with rigid performance specifications maintained by periodic maintenance inspection and adjustment, that different machines, and even different spindles on the same machine, vary in performance. The machines used for machining these specimens were identified by operators and supervisors as neither the best or worst but as average in condition and performance. Specifications of NC milling machines are given in Tables C-II, C-III and C-IV. Test component 622-005 represents an F-16 bulkhead section and was machined on a conventional profile mill since prototype components were manufactured in this manner and no NC program was available.

Cutters used for NC operations are purchased and maintained to GD/FW specifications. These specifications are required to assure optimum cutter performance and, equally important, provide reliable, consistent performance. Variation in performance of cutters from different manufacturers is unacceptable in efficient NC machining operations. Cutter specifications used to machine these test components are referenced in Figures C-6, C-7 and C-8.

Table C-V is a summary of cutter configurations used to machine test components and Table C-VI is a summary of machining parameters. Key identification elements in this summary are the test specimen drawing number and NC tape number. Insignificant NC operations such as drilling of hold down bolt holes were omitted from this report.

2.2 Hand Finishing

For the specimens and areas of specimens specified, hand finishing was done with hand held air driven disc sanders and by hand with grit paper. Sharp edges were broken with a file rather than the generally used scraper. The sharp edges were broken in this manner to prevent the possibility of the scraper creating burrs which would be a stress riser in the edge of the specimen and possibly cause an early failure. In some of the I beams where the as-machined finish was very good, extra hand finishing was done to increase the contrast between the as-machined and hand finished portions of the beam.

2.3 Surface Finish Data

Surface finish on each of the test specimens was measured in both the as-machined and hand finished areas. Measurements were made at several points on the web of each pocket and both the inner and outer surfaces of each flange. This data is summarized in Tables C-VII, C-VIII, C-IX, C-X and C-XI.

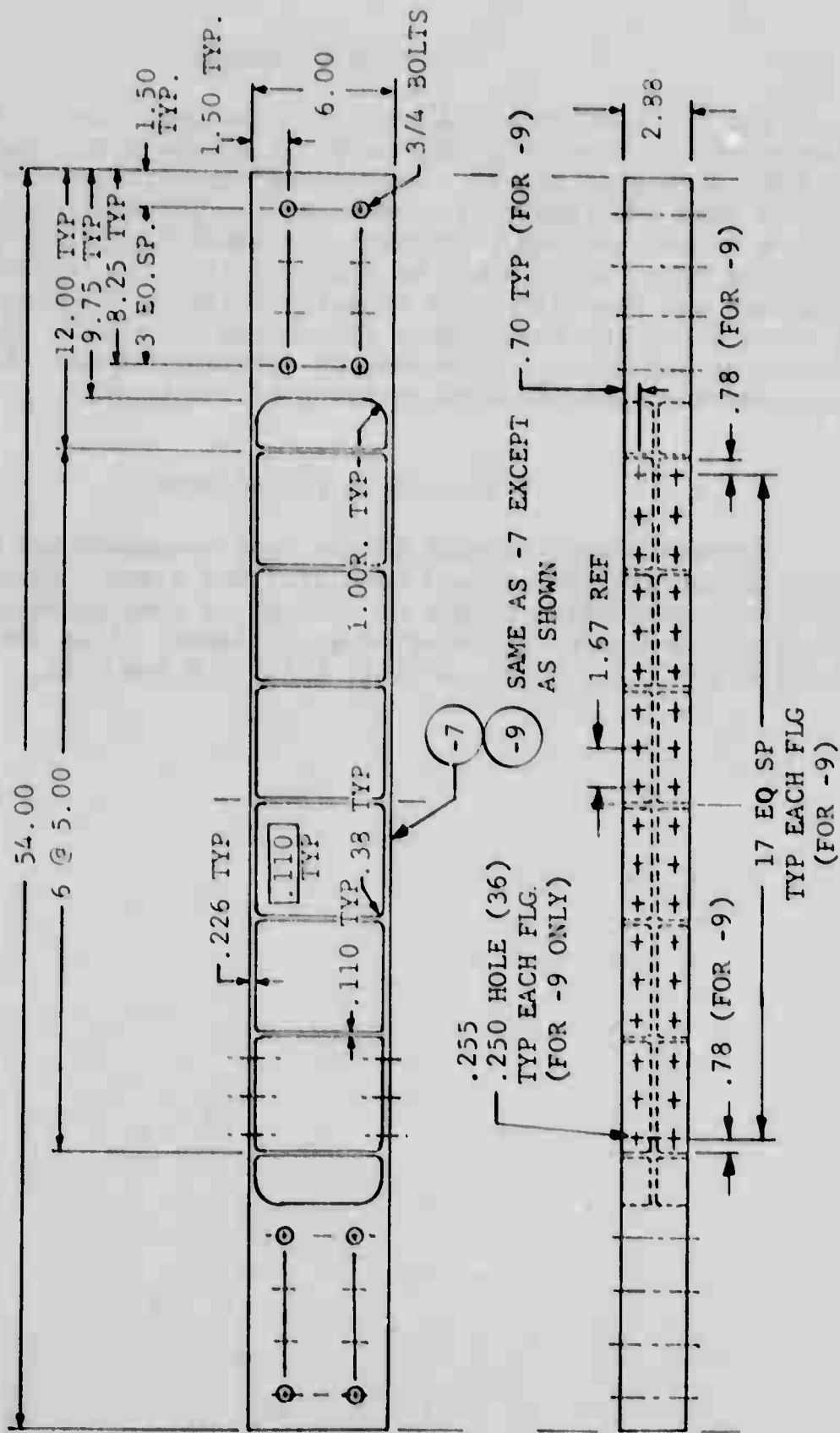

FIGURE C-1 ALUMINUM I-BEAM DEVELOPMENT TEST SPECIMEN, P/N 622-001

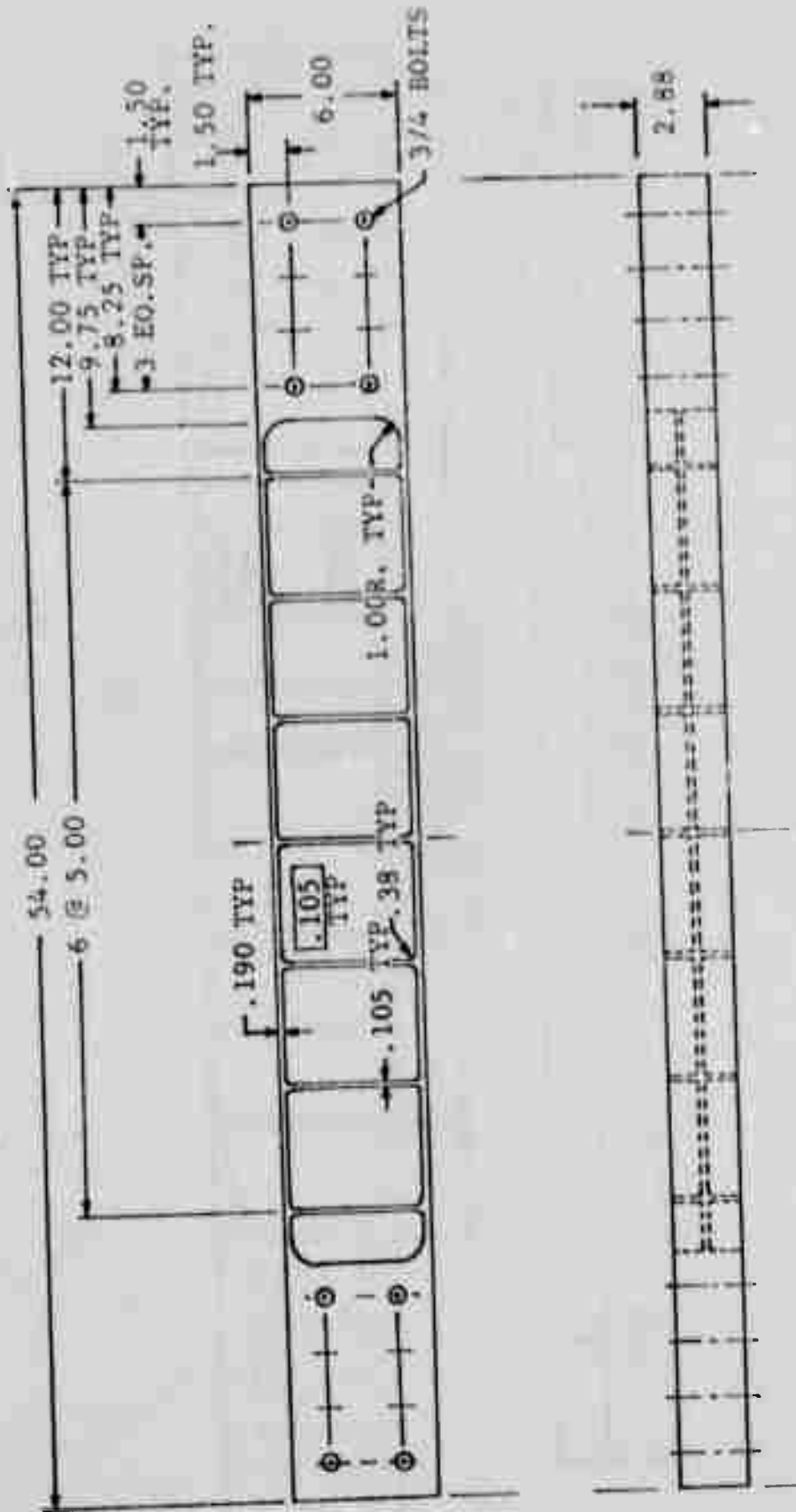

FIGURE C-2 TITANIUM I-BEAM DEVELOPMENT TEST SPECIMEN, P/N 622-002

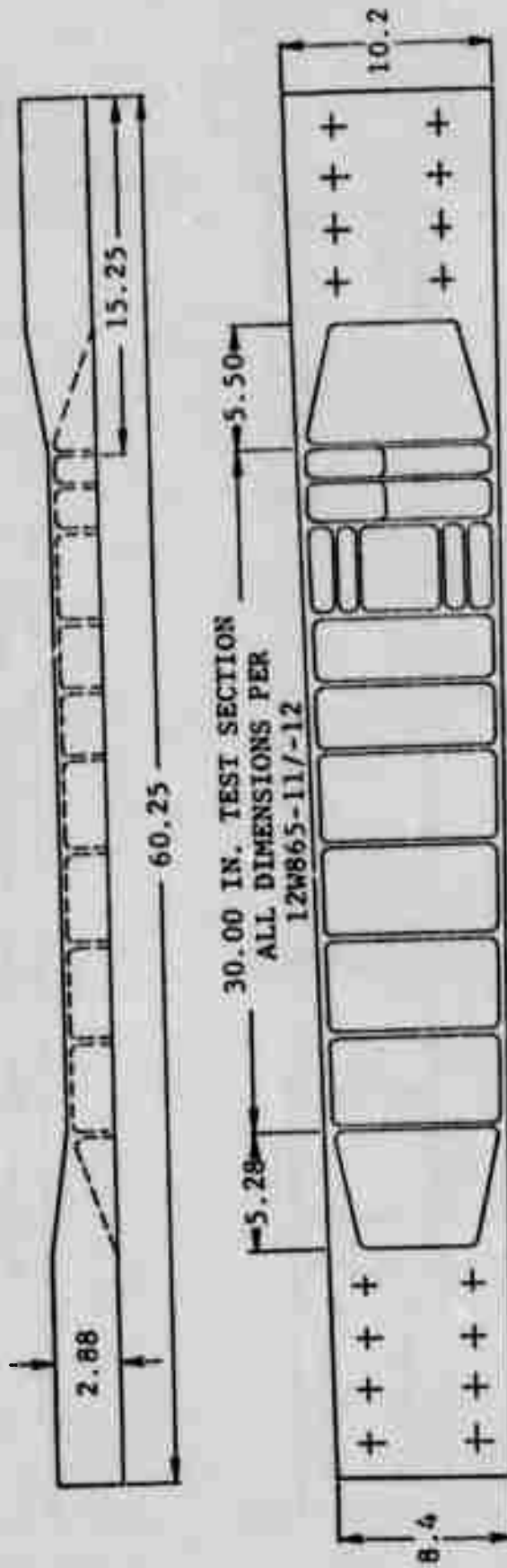

FIGURE C-3 F-111 WING REAR SPAR-INBD-VERIFICATION
 TEST SPECIMEN, P/N 622-003

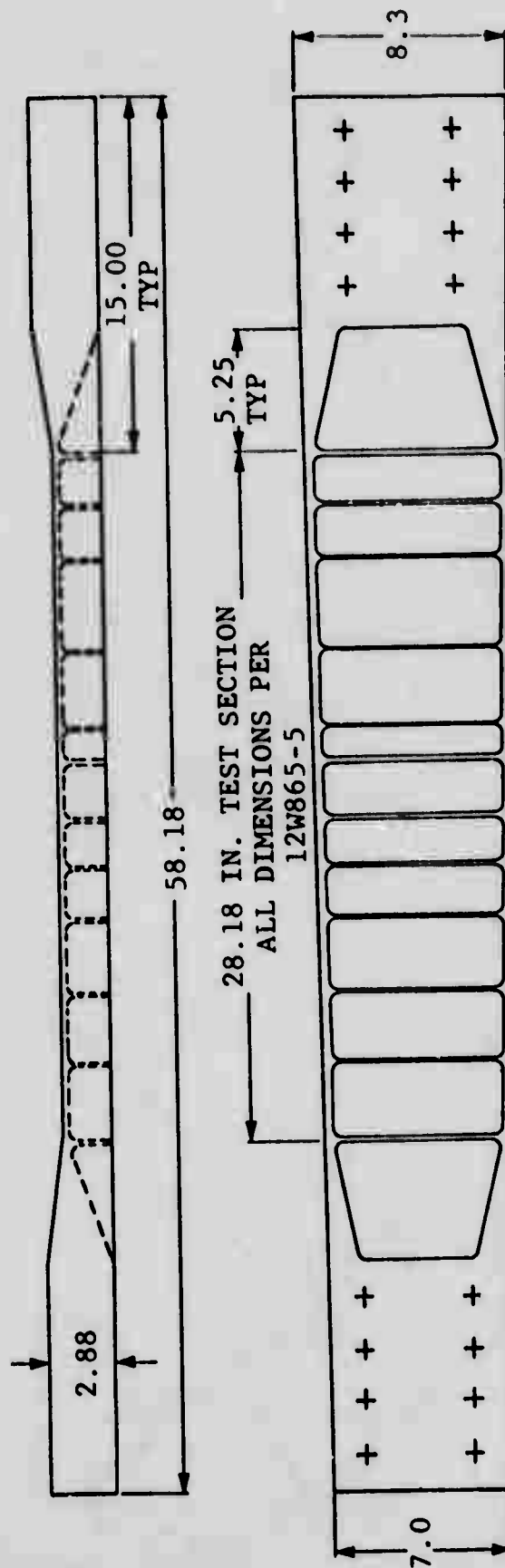

FIGURE C-4 F-111 WING REAR SPAR-OUTBD-VERIFICATION
 TEST SPECIMEN, P/N 622-011

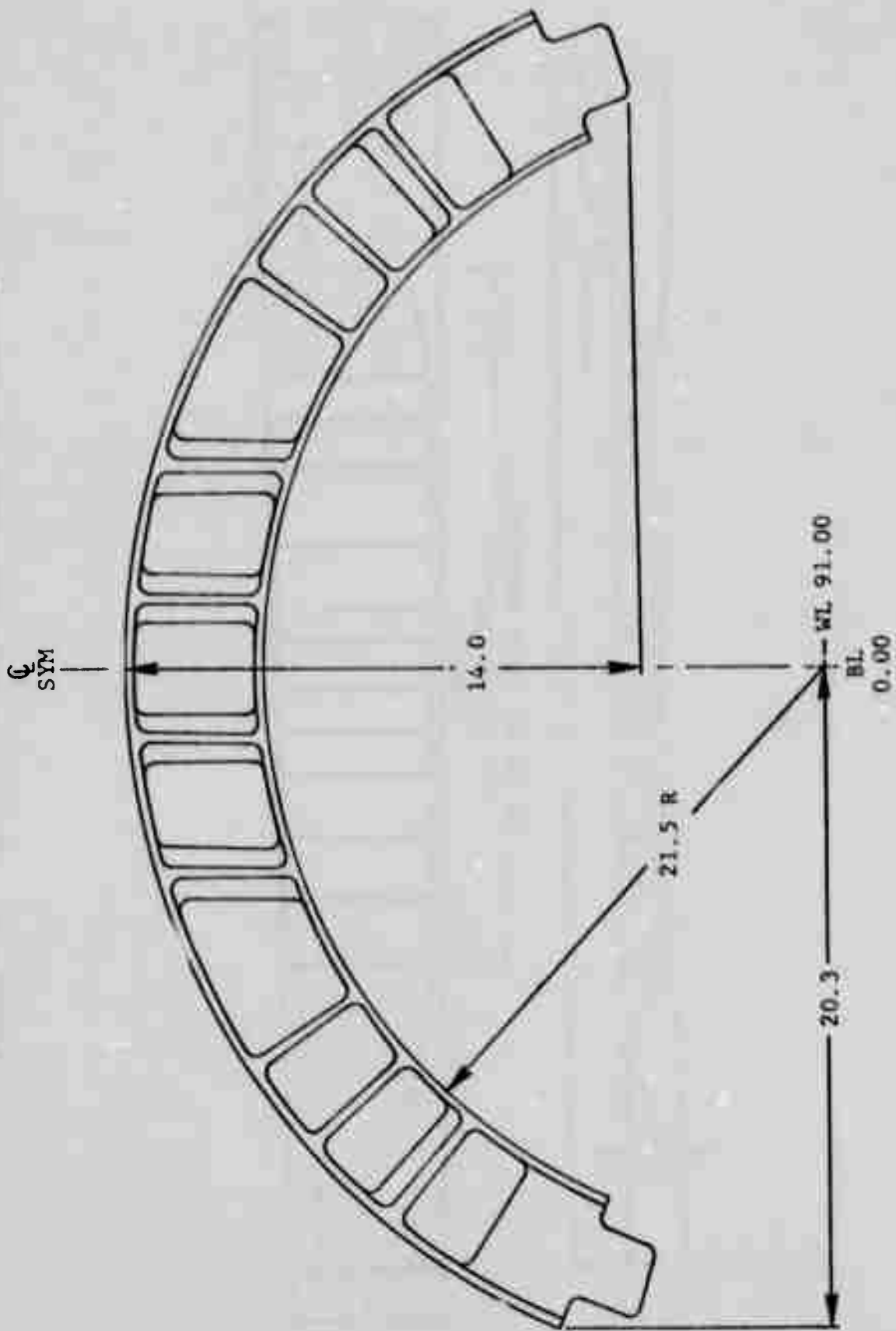

FIGURE C-5 YF-16 BULKHEAD VERIFICATION TEST SPECIMEN, P/N 622-005

CUTTING TOOL SPECIFICATIONS

SEC. 1 PAGE 9
A. REV. 6-22-70

TMS-CU-001
PROCUREMENT AND MAINTENANCE SPECIFICATIONS
standard (27°-30° helix) 2 flute end mills for aluminum

TMS-CU-30.001

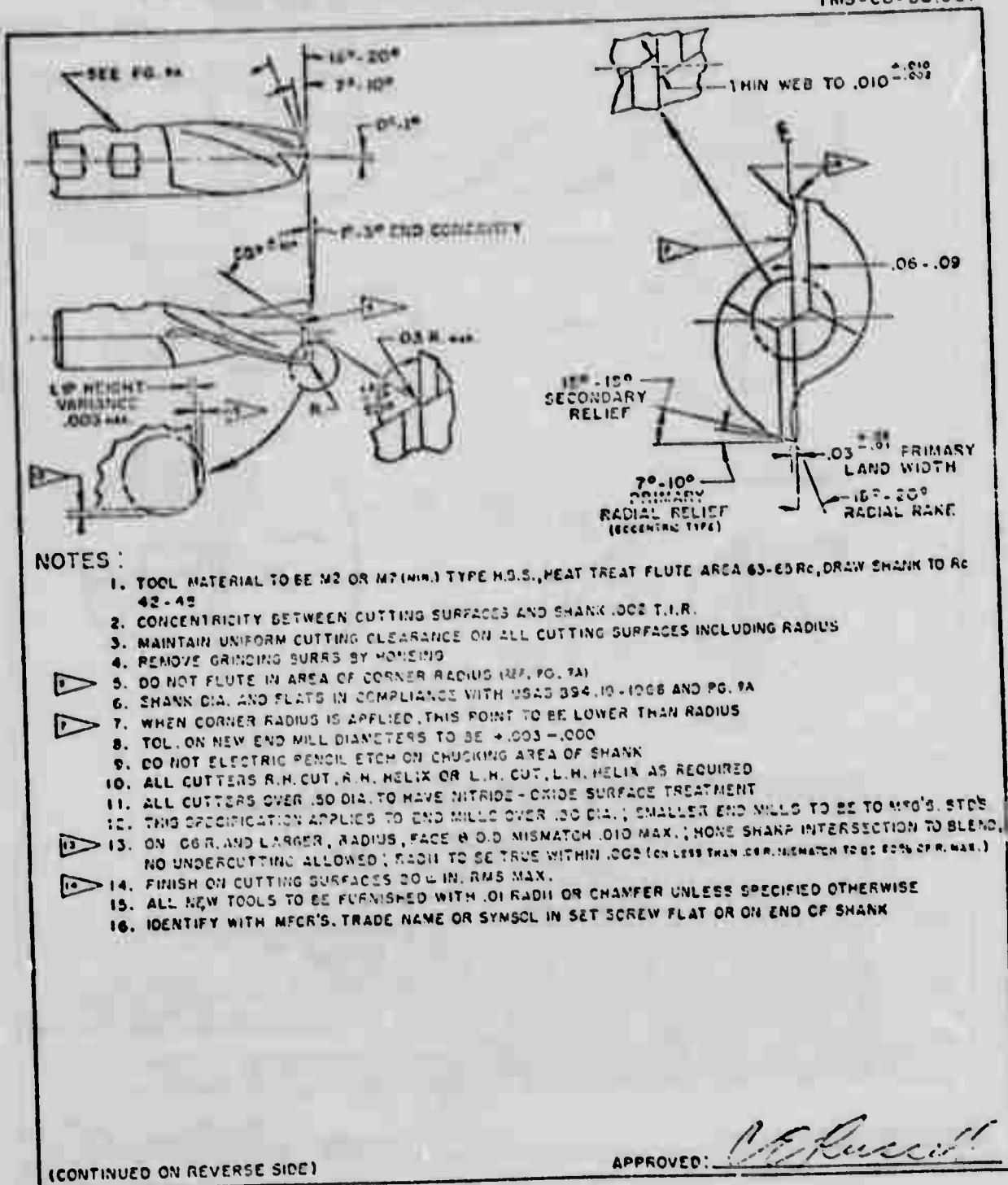

FIGURE C-6

CUTTING TOOL SPECIFICATION - STANDARD
2 FLUTE END MILLS FOR ALUMINUM

CUTTING TOOL SPECIFICATIONS

TMS-CU-001

PROCUREMENT AND MAINTENANCE SPECIFICATIONS

high helix (45°) aluminum cutting end mills

TMS-CU-45.001

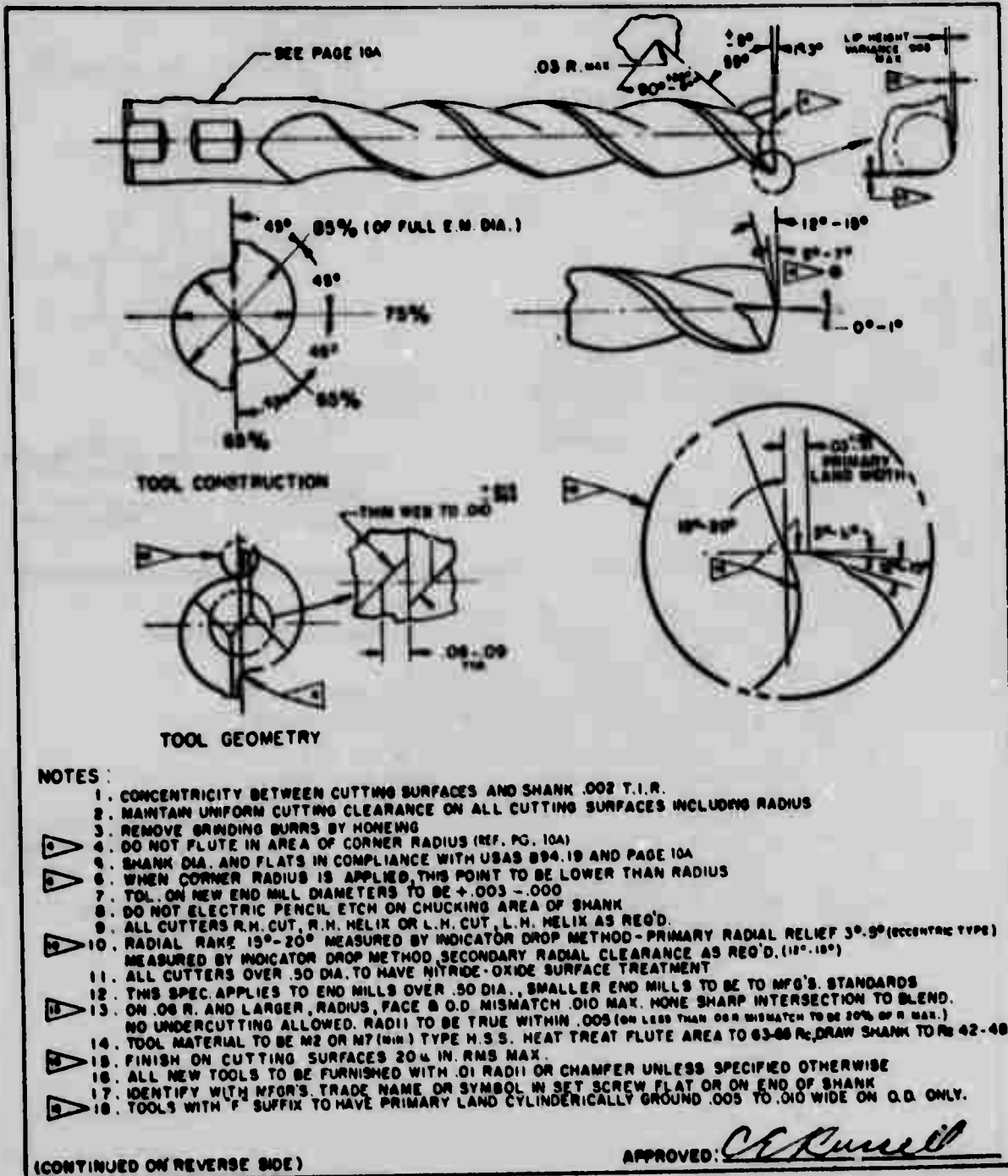

FIGURE C-7 CUTTING TOOL SPECIFICATION - HIGH HELIX ALUMINUM CUTTING END MILLS

CUTTING TOOL SPECIFICATIONS

SEC. 1 PAGE 10A
REV 10-11-7.

TMS - CU - 001 PROCUREMENT AND MAINTENANCE SPECIFICATIONS high helix (45°) aluminum cutting end mills

TMS - CU - 45.001

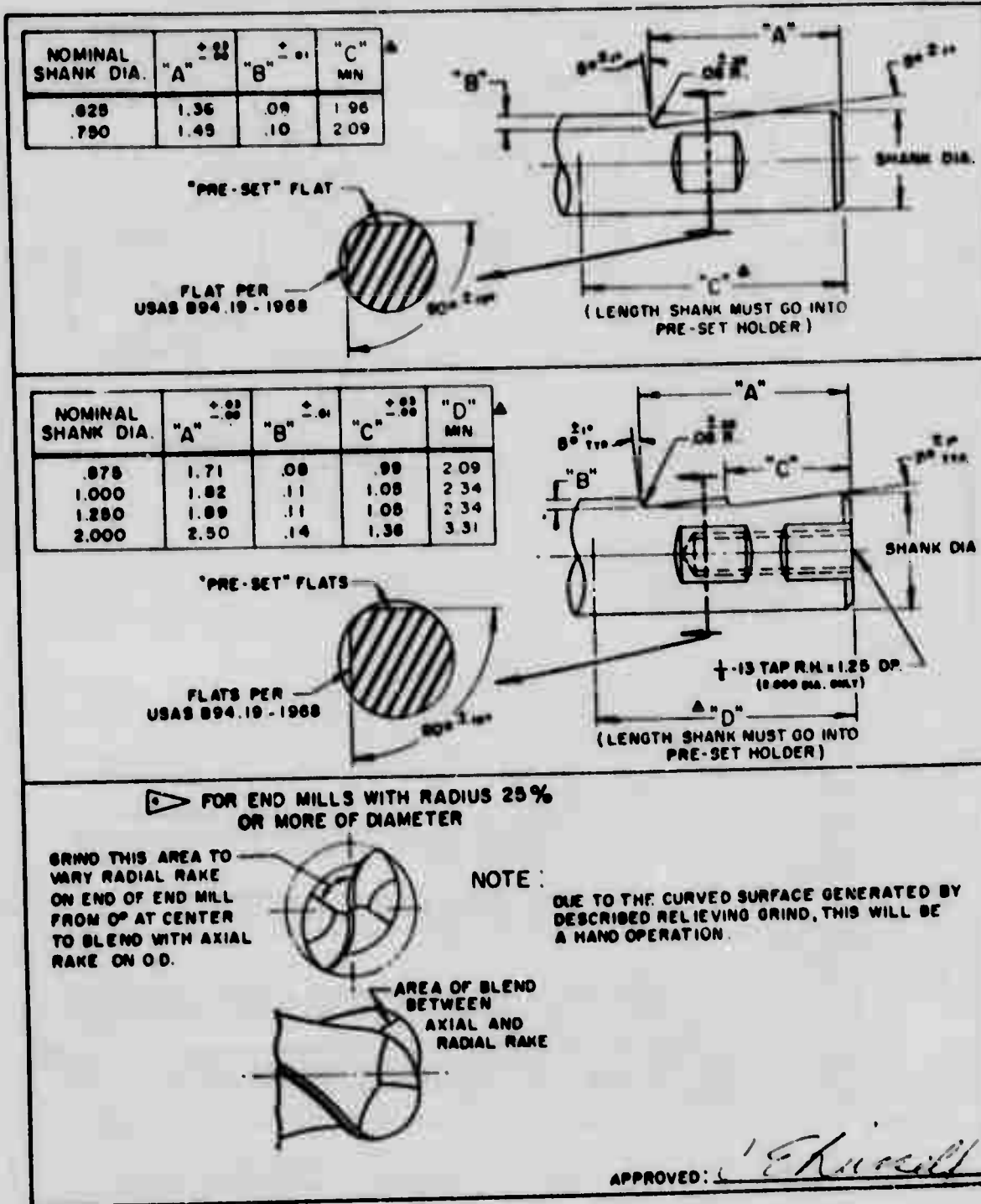

FIGURE C-7 (Cont'd)

CUTTING TOOL SPECIFICATIONS

SEC. 1 PAGE 8
REV. 3-16-70

TMS-CU-001 PROCUREMENT AND MAINTENANCE SPECIFICATIONS 4, 6 AND 8 FLUTE END MILLS FOR MACHINING HIGH STRENGTH AND HIGH TEMPERATURE ALLOYS

TMS-CU-25002

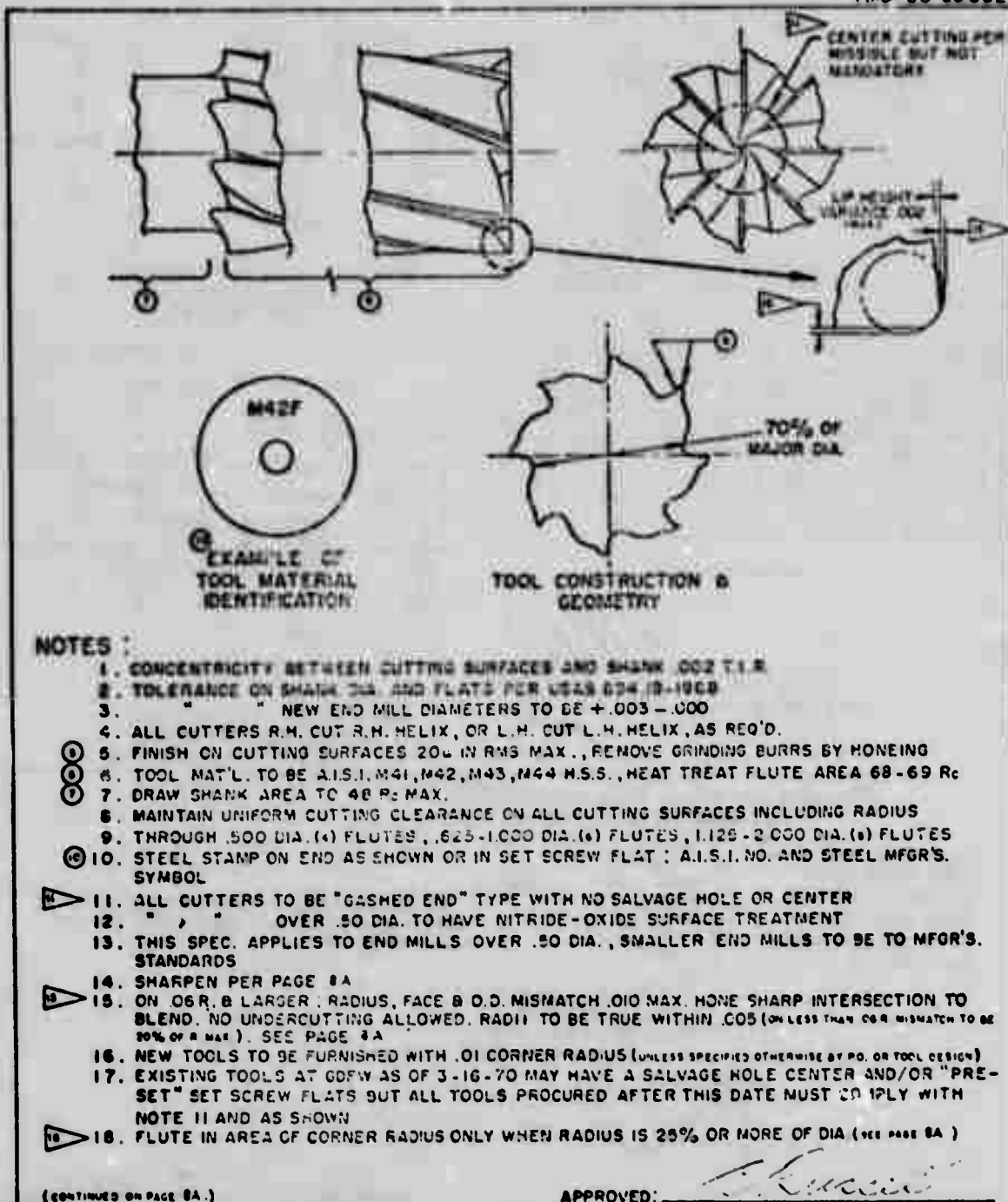

FIGURE C-8 CUTTING TOOL SPECIFICATION -
4, 6 & 8 FLUTE END MILLS

CUTTING TOOL SPECIFICATIONS

SEC. 1 PAGE 3A
3-16-70
(REVISED)

TMS-CU-001

PROCUREMENT AND MAINTENANCE SPECIFICATIONS

4, 6 AND 8 FLUTE END MILLS

(STEEL CUTTING)

TMS-CU-25 002

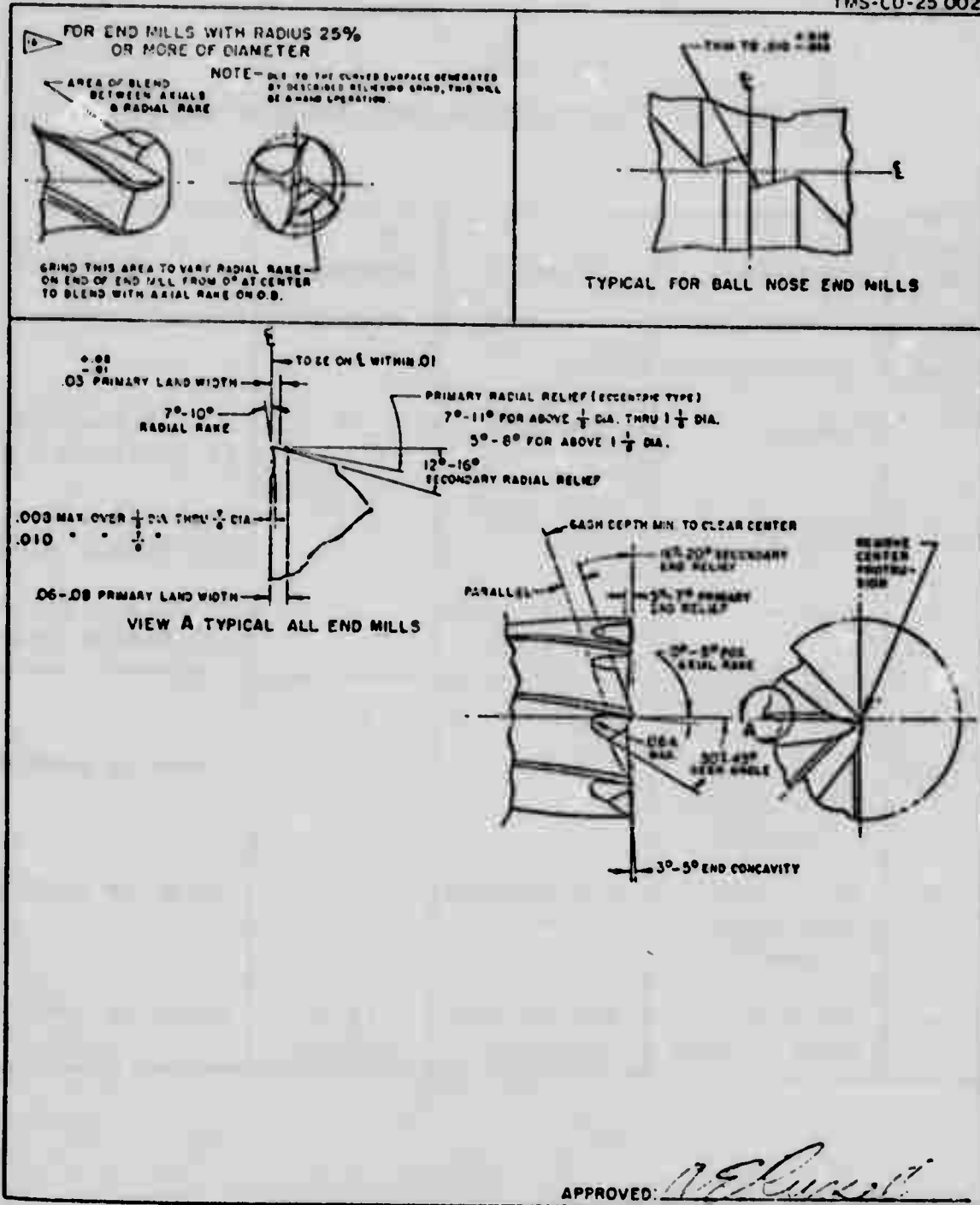

TABLE C-I VERIFICATION TEST PROGRAM SUMMARY

Test No.	Specimen	Material	No. of Specimens	Spectrum
Task I (Development Tests)				
1	I-beam	2124-T851	5	F-111A Phase I and II Training Usage
2	I-beam	2124-T851	7	YF-16 Air Superiority Random Ordered
3	I-beam	6Al-4V beta annealed	6	YF-16 Air Superiority Random Ordered
Task II (Verification Tests)				
4	F-111 Rear Spar Segment - Inboard	2124-T851	4	(Same as test #1)
5	F-111 Rear Spar Segment - Outb'd	7050-T73651	4	(Same as test #1)
6	YF-16 Bulk-head Segment	6Al-4V beta annealed	(two channels)	(Same as test #2)

TABLE C-II GIDDINGS & LEWIS (8 x 30) 3-AXIS
SKIN MILL SPECIFICATIONS

<p>MACHINE SPECIFICATIONS:</p> <p>3-Axis Mill Table Size Horsepower Spindles Spindle Speeds Control System Approximate Location Task Center High Strength Machining</p>	<p>(1) Machine 92" x 360" 50/100 (2) 1800/3600 RPM Bunker-Ramo 3200 Col 72S 231 No</p>
<p>PROGRAMMING SPECIFICATIONS:</p> <p>Postprocessor (1-4 Format) Rapid Traverse</p> <p>Maximum Travel</p> <p>INTCOD Commands Required (Optional)</p> <p>SPINDL Commands COOLNT Commands TOOLNO Commands (Optional) Gerber ADM Format Statement</p>	<p>MACHIN/TRW3GD,4 100 IPM (X & Y-Axis) 55 IPM (Z-Axis) X-Axis: 360 Y-Axis: 92 Z-Axis: 12 INTCOD/8,360 INTCOD/9,92 INTCOD/10,12 Not Required Required Required for Preset Cutters FSTI X14, Y14, Z14</p>

TABLE C-III ONSRUD 4-AXIS MILL SPECIFICATIONS

<p>MACHINE SPECIFICATIONS:</p> <p>4-Axis Mill Table Size Horsepower Spindles Spindle Speeds Control System Approximate Location Task Center High Strength Machining</p>	<p>Machines (4) 96" x 180" 30/100 (2) 9-3600 RPM Bunker-Ramo 3000 Col 62-68S 228 Yes</p>
<p>PROGRAMING SPECIFICATIONS:</p> <p>Postprocessor (1-4 Format) Rapid Traverse</p> <p>Maximum Travel</p> <p>MULTAX & V4AXIS/ON Commands INTCOD Commands SPINDL & COOLNT Commands TOOLNO Commands (Optional) Gerber ADM Format Statement</p>	<p>MACHIN/TRW4GD, 1 100 IPM (X & Y-Axis) 55 IPM (Z-Axis) 55 DPM (Tilt) X-Axis: 180 Y-Axis: 96 Z-Axis: 18 Tilt: +15° Required Noc Required Not Required Required for Preset Cutters FSTI X14, Y14, Z14</p>

TABLE C-IV GIDDINGS & LEWIS (8 x 30) 4-AXIS
MILL SPECIFICATIONS

<p>MACHINE SPECIFICATIONS:</p> <p>4-Axis Mill Table Size Horsepower (2) Spindles Spindle Speeds, (2) Control System Approximate Location Task Center High Strength Machining</p>	<p>Machine (1) 92" x 360" 50/100</p> <p>1900/3600 RPM Bendix Dynapath 24 Col 60S 230 No</p>
<p>PROGRAMING SPECIFICATIONS:</p> <p>Postprocessor (1-4 Format) Rapid Traverse</p> <p>Maximum Travel</p> <p>MULTAX & V4AXIS/ON Commands INTCOD Commands SPINDL Commands COOLNT Commands TOOLNO Commands (Optional) Gerber ADM Format Statement</p>	<p>MACHIN/BENDX4 100 IPM (X & Y-Axis) 55 IPM (Z-Axis) 55 DPM (Tilt) X-Axis: 360 Y-Axis: 92 Z-Axis: 18 Tilt: $+15^{\circ}$ Required Not Required Not Required Required Required for Preset Cutters FSNI X14, Y14, Z14</p>

TABLE C-V

SIZES AND GEOMETRY OF END MILLS USED TO MACHINE TEST PARTS

CD/FW Spec.	Dis.	Flute Length	No. of Flutes	Radial Bake	Helix Angle	Radial Bel. (+2°)	Radial & Axial Clear. (+3°)	Corner Radius	HSS Grade	Hardness (Rc)
TMS-CU-30.001	.50	2.50	2	15°-20°	30°	8°	16°	.12	M2	64-66
	.75	2.25	2	15°-20°	30°	8°	16°	.12		
	1.50	3.00	2	15°-20°	30°	8°	16°	.12		
	1.50	3.00	2	15°-20°	30°	8°	16°	.75		
	2.00	2.00	2	15°-20°	30°	8°	16°	.50		
	2.00	3.00	2	15°-20°	30°	8°	16°	.01		
	2.00	3.00	2	15°-20°	30°	8°	16°	.12		
	TMS-CU-45.001	.75	3.00	2	15°-20°	45°	4°	14°		
.75		3.00	2	15°-20°	45°	4°	14°	.38		
1.00		2.00	2	15°-20°	45°	4°	14°	.12		
TMS-CU-25.002	.75	1.62	6	7°-10°	25°	9°	14°	.12	M42	68-69
	1.50	2.00	8	7°-10°	25°	6°	14°	.12		
	2.00	2.00	8	7°-10°	25°	6°	14°	.12		
	2.00	4.00	8	7°-10°	25°	6°	14°	.01		

TABLE C-VI

SUMMARY OF PARAMETERS USED IN MACHINING SPECIMENS - END MILLING

WORKPIECE MATERIAL	DMC NO.	MACHINE TYPE	TAPE NO.	CUTTER SPEC.	CUTTING SPEED (SPM)	FEED (IPT)	AXIAL DEPTH	RADIAL DEPTH	CUTTING FLUID
2124T851 Alum.	622-001	3-Axis NC 50/100 HP 1800/1600 RPM G&L	2	2.0x3.0x.01R TMS-CU-30.001	942	.012 (42 IPM)	1.0 3.0	.50 (Rough) .06 (Finish)	Spray Mist W.S.O.
			4	2.0x3.0x.12R	942		1.500	1.00	
			5	.75x2.25x.12R	350		1.50	.06	
			20	2.0x4.0x.01R TMS-CU-25.002	38	.0055	3.00	.50	Flood W.S.O.
			30	1.5x2.0x.12R	38	.005	1.50	.75	
			51 52 53	2.0x2.0x.12R	38	.0055	1.50	1.00	
60	.75x1.62x.12R	34	.003	1.50	.06				
*Except corners and final "Free Pass" where cutter path is repeated with "0" in feed.									
2124T851 Alum.	622-003	4-Axis NC 30 HP 36/3500 RPM G&L	8	2.0x3.0x.12R TMS-CU-30.001	942	.011 (40 IPM)	.25	1.00	Spray Mist W.S.O.
			9	2.0x3.0x.12R	942		.25	1.00	
			10	2.0x3.0x.12R TMS-CU-30.001	945	.011	.25	2.00	
			11 12				1.50	1.00	

TABLE C-VI (CONT'D)

WORKPIECE MATERIAL	DWG. NO.	MACHINE TYPE	TAPE NO.	CUTTER SPEC.	CUTTING SPEED(SFM)	FEED (IPT)	AXIAL DEPTH	RADIAL DEPTH	CUTTING FLUID
2124T851 Alum.	622-011	4-Axis N/C 50/100 HP 1800/3600 RPM G&L	20	2.0x2.0x.50R TMS-CU-30.001	942	.011	.25	1.00	Spray Mist W.S.O.
			21	2.0x2.0x.12R	700	.006	1.50	1.00	
			22				0-1.50 (Slope)		
			23	1.5x3.0x.12R	700		1.50	.75 (Rough) .06 (Finish)	
			24	1.0x2.0x.12R TMS-CU-45.001	470		1.00	.50 (Rough) .06 (Finish)	
			25	.75x2.25x.128 TMS-CU-30.001	350		1.50	.06	
			97	.50x2.50x.12R			1.50	.06	

TABLE C-VI (CONT'D)

WORKPIECE MATERIAL	DWG. NO.	MACHINE TYPE	TAPE NO.	CUTTER SPEC.	CUTTING SPEED(SFM)	FEED (IPT)	AXIAL DEPTH	RADIAL DEPTH	CUTTING FLUID
2124T851 Alum.	622-003	4-Axis NC 30 HP 36/3600 RPM G & L	142	SPECIAL CONFIGURATION CUTTER					
			143						
			13	.75x3.0x.12R TMS-CU-45.001	350	.011	1.50	.25 (Rough) .06 (Finish)	
			14					.06	
			15	(4-Axis Cut)					
			16						
			17	1.5x3.0x.75 (Keller Type Cut)	470	.011	Slope 0-150		
			18						
			19						
			20	.75x3.0x.38R (RH End) (LH End)	350	.011	.06 Finish Keller Mill		
			21						
6A14V b.a. Titanium	622-005	Profile Mill							Flood W.S.O.

TABLE C-VII I-BEAM TEST SPECIMENS SURFACE FINISH DATA - ALUMINUM, P/N 622-001

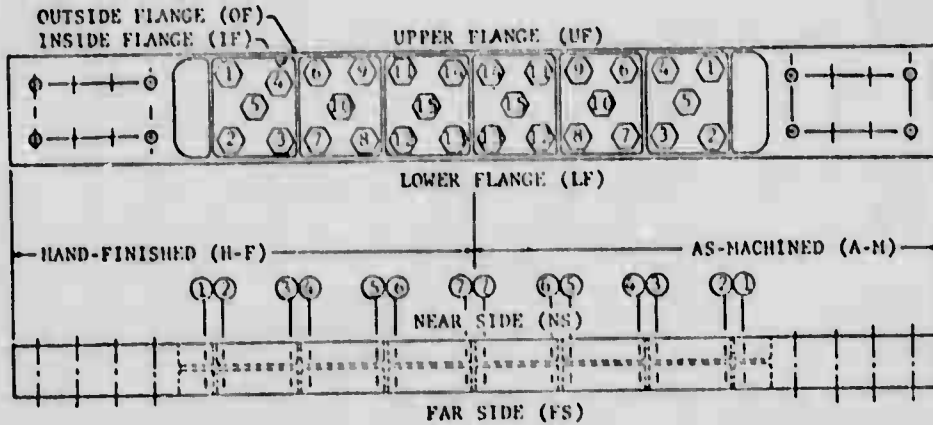

(X) - WEB LOCATION
(X) - FLANGE LOCATION

S/N	MATERIAL	D/L	N/F	HAND-FINISHED							AS-MACHINED								
				1	2	3	4	5	6	7	7	6	5	4	3	2	1		
755	Al	UF	NS	54	58	56	44	32	45	53	104	100	119	112	109	106	117		
			FS	50	27	35	60	43	58	51	113	108	109	116	126	109	109		
		LF	NS	44	54	42	52	56	38	26	42	114	113	110	110	110	107		
			FS	26	57	56	58	55	47	52	103	127	110	114	113	114	110		
		OUTSIDE FLANGE SURFACE, MIN., AA				29		32		23		35		26		31		28	
						17		19		20		34		34		31		34	
757	Al	UF	NS	27	16	30	15	24	20	23	43	62	45	63	49	55	26		
			FS	17	16	19	35	27	29	27	64	45	49	52	55	44	40		
		LF	NS	13	24	24	31	23	33	37	34	33	49	47	36	31	12		
			FS	16	17	19	36	38	32	35	58	63	67	43	51	68	24		
		OUTSIDE FLANGE SURFACE				17		16		10		29		33		30		29	
						9		8		7		9		36		33		34	
758	Al	UF	NS	15	16	13	11	25	27	26	65	64	58	58	78	45	88		
			FS	13	23	24	15	26	10	14	59	78	38	79	53	73	68		
		LF	NS	15	9	11	10	7	16	19	70	64	66	67	73	74	83		
			FS	15	15	14	18	23	13	15	73	55	63	52	56	47	88		
		OUTSIDE FLANGE SURFACE				7		7		6		41		39		36		39	
						17		15		19		18		33		42		33	
759	Al	UF	NS	28	44	45	45	38	37	29	50	52	49	40	52	46	51		
			FS	32	36	38	34	37	32	29	38	35	41	36	44	41	36		
		LF	NS	36	38	35	35	30	34	39	53	63	52	54	50	52	51		
			FS	29	27	33	31	27	28	43	39	38	36	35	41	42	37		
		OUTSIDE FLANGE SURFACE				26		24		27		24		22		23		24	
						22		22		24		27		21		28		22	
764	Al	UF	NS	17	19	28	20	20	33	21	31	36	38	33	40	33	32		
			FS	24	29	27	23	28	20	23	33	39	32	34	36	41	40		
		LF	NS	25	19	21	21	21	17	14	34	33	30	30	34	38	45		
			FS	28	29	25	26	30	32	33	32	33	30	42	43	47	58		
		OUTSIDE FLANGE SURFACE				27		25		28		26		23		23		22	
						30		35		27		21		25		23		21	
766	Al	UF	NS	20	18	19	22	24	23	23	53	68	47	55	60	62	49		
			FS	15	22	21	19	25	26	23	55	83	85	73	71	69	79		
		LF	NS	25	20	23	40	37	35	29	63	52	60	73	55	69	58		
			FS	37	20	24	24	15	16	15	54	53	81	62	74	61	77		
		OUTSIDE FLANGE SURFACE				9		4		5		3		33		40		37	
						13		11		8		7		24		33		29	

TABLE C-VII (CONT'D)

S/P	DATE	D/I	S/E	ROOF-FINISHED							AS-BUILT						
				1	2	3	4	5	6	7	1	2	3	4	5	6	7
760	A1	UP	NS	18	19	21	22	31	20	48	69	60	49	60	43	53	
			FS	10	17	26	12	19	28	33	69	47	61	58	74	48	60
		LF	NS	15	18	30	30	25	21	21	47	80	55	64	58	59	46
			FS	16	17	16	25	20	25	26	43	57	52	64	60	61	40
		UP	NS	25		16		17		10	27	23		19		28	
			FS	6		4		2		8	25	33		25		22	
765	A1	UP	NS	18	16	18	13	19	13	14	71	64	50	73	51	66	51
			FS	12	17	19	15	19	13	17	63	48	52	59	63	44	41
		LF	NS	10	13	17	18	11	16	13	96	102	79	59	69	66	59
			FS	14	18	21	17	14	16	15	54	43	50	36	41	48	60
		UP	NS	4		4		3		2	29	28		23		30	
			FS	9		8		7		8	28	31		23		23	
761	A1	UP	NS	23	12	27	16	18	15	16	48	48	59	40	33	62	54
			FS	20	8	12	18	18	22	20	117	108	68	66	86	60	47
		LF	NS	21	17	20	14	14	14	16	47	32	29	41	52	58	47
			FS	17	25	23	23	26	17	20	45	34	40	68	87	38	85
		UP	NS	17		14		12		8	28	27		72		37	
			FS	3		7		8		7	34	36		36		30	
763	A1	UP	NS	12	14	13	12	14	11	14	43	51	57	37	57	70	69
			FS	12	16	9	16	13	12	13	52	52	57	66	49	63	43
		LF	NS	13	14	17	14	16	18	12	52	44	52	58	64	61	46
			FS	16	12	13	12	10	12	10	54	51	61	57	47	37	68
		UP	NS	9		9		12		6	30	34		33		43	
			FS	6		6		9		11	62	57		50		42	
762	A1	UP	NS	9	12	15	10	13	9	5	77	54	34	60	54	40	107
			FS	15	15	12	16	18	13	12	76	53	58	64	60	63	56
		LF	NS	10	18	18	16	15	18	16	43	50	61	78	48	55	43
			FS	14	14	13	13	14	13	12	51	60	60	45	70	73	59
		UP	NS	7		9		5		2	19	63		20		51	
			FS	8		6		6		5	41	49		43		30	
318	A1	UP	NS	14	13	13	10	12	17	12	41	66	53	34	46	41	60
			FS	9	12	10	12	9	12	12	34	39	54	47	32	37	22
		LF	NS	13	14	16	16	14	12	11	37	35	35	47	40	58	34
			FS	13	14	13	13	13	18	13	70	41	63	33	50	36	52
		UP	NS	5		6		5		3	15	12		17		15	
			FS	4		2		4		4	20	18		25		22	

TABLE C-VIII 1-BEAM TEST SPECIMENS SURFACE FINISH DATA -
TITANIUM, P/N 632-002

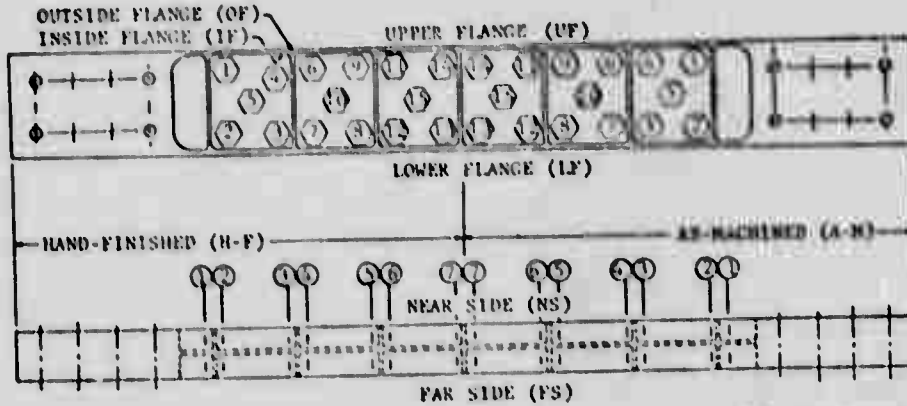

S/N	MATERIAL	D/L	N/F	HAND-FINISHED							AS-MACHINED								
				1	2	3	4	5	6	7	7	6	5	4	3	2	1		
771	T1	UF	NS	23	16	17	16	14	22	20	42	38	45	42	44	45	44		
			FS	48	51	52	26	38	30	20	120	95	95	90	85	80	95		
		LF	NS	43	36	34	42	47	37	30	42	44	40	40	38	35	50		
			FS	23	41	27	27	23	25	20	85	88	94	110	85	100	105		
		UF	NS	20		18		18		20	70	80		100		95			
			FS	21		17		14		14	74	73		68		70			
		776	T1	UF	NS	44	36	42	34	32	23	33	65	70	58	68	55	68	63
					FS	26	22	34	28	27	25	25	33	34	28	28	37	30	26
LF	NS			29	28	38	52	44	48	37	75	74	84	68	64	64	56		
	FS			23	18	30	22	18	20	26	33	31	25	25	23	34	34		
UF	NS			34		30		23		20	58	55		58		55			
	FS			34		34		30		30	52	56		55		60			
769	T1			UF	NS	44	39	28	48	36	35	44	88	52	70	64	57	51	40
					FS	38	33	35	34	39	33	35	35	33	45	43	42	28	39
		LF	NS	45	36	42	41	43	38	35	51	55	61	55	48	47	46		
			FS	39	26	30	28	36	32	30	37	42	52	35	39	35	42		
		UF	NS	24		22		23		21	58	60		55		52			
			FS	11		34		32		25	62	59		57		60			
		768	T1	UF	NS	55	53	47	45	45	51	46	68	64	62	58	75	65	58
					FS	37	38	37	47	37	38	38	38	38	43	32	40	35	28
LF	NS			55	38	48	45	48	43	43	63	70	60	64	53	67	57		
	FS			30	25	25	30	44	37	28	32	28	37	32	40	25	30		
UF	NS			27		30		27		24	75	85		85		80			
	FS			30		35		34		25	105	85		100		85			
767	T1			UF	NS	36	34	37	33	26	38	39	40	28	31	40	42	35	37
					FS	43	47	45	34	38	56	48	80	75	85	65	68	85	73
		LF	NS	52	30	40	35	37	42	47	47	35	30	33	45	28	32		
			FS	50	47	47	50	52	46	42	68	67	38	68	55	60	140		
		UF	NS	28		25		20		25	48	55		57		60			
			FS	25		27		28		37	75	70		64		62			
		772	T1	UF	NS	48	33	47	27	25	38	31	34	28	33	35	36	30	33
					FS	43	28	35	38	55	25	37	55	65	48	62	58	60	58
LF	NS			25	20	37	18	43	45	42	33	30	27	30	28	38	37		
	FS			42	37	37	36	34	23	18	64	55	60	62	65	60	65		
UF	NS			24		28		20		30	75	75		72		70			
	FS			34		27		30		30	100	95		95		85			

TABLE C-IX F-111 WING REAR SPAR - INBD - SURFACE
FINISH DATA, W/N 622-003

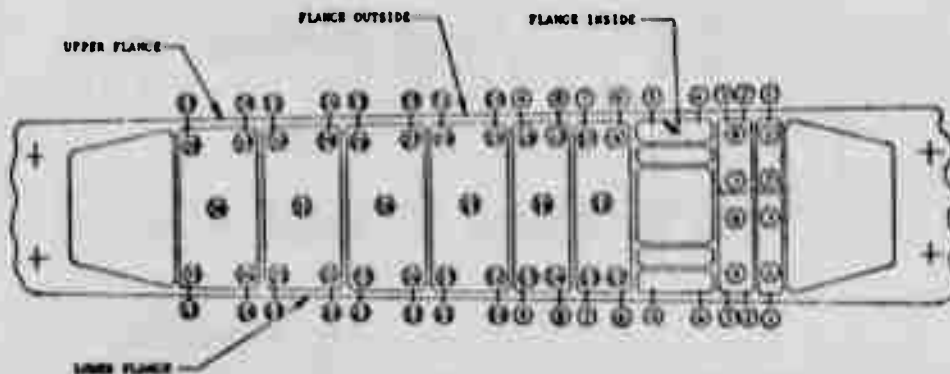

(X) - WEB LOCATION
(X) - FLANGE LOCATION

POINT	WEB			
	HAND FINISHED		AS MACHINED	
	-7	-8	-9	-10
1	30	59	41	82
2	26	47	37	66
3	26	25	40	62
4	24	22	30	60
5	48	25	65	88
6	30	32	28	95
7	33	42	88	100
8	25	30	77	107
9	22	40	40	77
10	40	44	69	72
11	17	37	43	85
12	48	38	64	63
13	41	25	52	56
14	38	25	80	63
15	24	19	56	58
16	48	32	55	88
17	36	37	55	52
18	36	18	53	56
19	37	28	67	73
20	49	44	57	70
21	36	46	56	61
22	31	43	71	105
23	26	20	50	61
24	32	26	129	33
25	25	20	64	68
26	20	28	44	170
27	23	33	98	93
28	27	25	67	46
29	36	20	97	45
30	35	25	48	81
31	35	40	60	135
32	37	36	62	57
33	32	41	139	83
34	37	44	55	71
35	40	30	73	62
36	41	43	48	73
37	59	42	94	71
38	28	31	74	100

POINT	UPPER FLANGE				LOWER FLANGE			
	HAND FINISHED		AS MACHINED		HAND FINISHED		AS MACHINED	
	-7	-8	-9	-10	-7	-8	-9	-10
OUTSIDE								
1	20	30	30	32	18	30	22	25
2	18	35	29	28	29	26	19	34
3	17	34	50	33	22	37	18	32
4	17	31	29	30	25	40	18	24
5	14	27	39	31	23	39	18	34
6	15	43	36	47	27	31	20	41
7	18	44	30	33	22	71	17	27
8	15	31	32	28	24	42	20	29
9	20	30	26	24	24	41	20	38
10	34	37	25	21	23	28	22	22
11	20	37	24	31	30	31	18	22
12	15	41	28	32	25	32	27	21
13	11	32	57	33	16	40	21	26
14	22	28	24	32	17	31	18	26
15	17	33	29	28	28	36	19	20
16	20	29	37	24	20	38	19	23
17	17	28	24	35	30	30	24	49
INSIDE								
1	27	28	27	49	24	18	31	50
2	25	33	19	48	13	28	26	39
3	34	30	26	43	17	30	30	49
4	23	28	23	50	26	17	32	42
5	27	22	27	65	29	34	17	116
6	29	26	25	49	18	32	27	48
7	27	30	26	57	13	18	30	38
8	30	30	37	52	14	31	29	62
9	29	25	36	47	17	34	25	49
10	34	32	31	80	18	33	20	61
11	34	27	30	48	19	15	25	41
12	27	31	32	32	20	31	33	48
13	26	27	35	34	29	21	43	34
14	26	24	19	52	27	14	28	37
15	22	30	26	44	14	39	27	60
16	28	29	23	63	38	18	37	36
17	28	31	20	58	28	16	38	111

TABLE C-X F-111 WING REAR SPAR - OUTRD - SURFACE
FINISH DATA, P/N 622-011

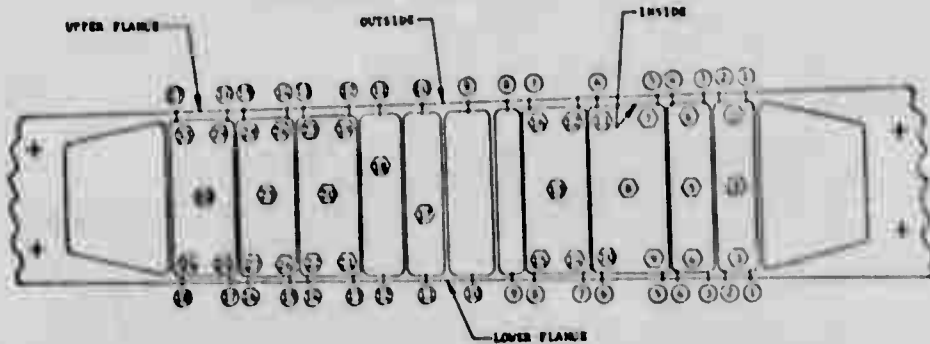

⊗ - FLANGE LOCATION
⊗ - WEB LOCATION

POINT	WEB				POINT	UPPER FLANGE				LOWER FLANGE			
	HAND		AS			HAND		AS		HAND		AS	
	FINISHED	MACHINED	FINISHED	MACHINED		FINISHED	MACHINED	FINISHED	MACHINED	FINISHED	MACHINED	FINISHED	MACHINED
	S/N	S/N	S/N	S/N	S/N	S/N	S/N	S/N	S/N	S/N	S/N	S/N	S/N
	751	752	753	754		751	752	753	754	751	752	753	754
1	31	24	97	172	OUTSIDE								
2	32	34	38	175	1	20	18	27	25	20	23	28	22
3	22	42	86	180	3	19	19	28	33	20	23	33	28
4	24	31	95	175	5	18	20	22	31	19	25	28	37
5	28	30	91	158	7	21	23	28	36	18	26	32	22
6	27	27	68	170	9	24	23	27	33	20	26	27	22
7	29	31	130	74	10	22	21	24	27	21	27	25	23
8	29	35	97	65	11	21	16	27	24	18	26	27	22
9	52	32	98	58	12	24	18	29	26	23	29	34	24
10	25	30	120	100	14	20	20	25	22	22	22	28	18
11	29	42	58	34	16	22	22	32	23	21	24	34	33
12	36	34	98	52	18	24	22	32	32	22	25	26	27
13	27	37	154	141	INSIDE								
14	39	33	70	190	1	27	27	70	74	24	43	148	75
15	42	31	124	83	2	29	31	115	54	28	34	165	95
16	38	33	40	30	3	28	29	120	68	29	38	75	65
17	37	48	74	290	4	32	32	90	60	22	23	100	65
18	32	38	152	165	5	33	40	95	115	27	43	102	38
19	22	46	155	48	6	38	44	96	55	28	42	104	100
20	25	43	86	88	7	28	47	203	90	25	44	75	58
21	26	31	155	134	8	26	48	80	50	22	40	187	90
22	29	38	50	80	9	29	34	110	200	27	31	150	210
23	35	40	38	22	10	27	37	60	115	23	32	146	125
24	29	32	110	120	11	32	40	95	100	26	15	78	30
25	21	44	150	75	12	28	27	70	55	30	41	137	95
26	29	38	124	50	13	39	43	52	50	25	37	99	32
27	22	41	45	72	14	34	37	85	68	24	44	96	30
28	21	35	58	34	15	36	37	138	48	25	45	94	41
29	33	42	60	45	16	35	36	94	97	27	45	149	58
30	24	46	95	106	17	39	39	80	110	26	38	104	25
31	24	34	75	120	18	41	42	80	125	29	39	172	41
32	15	41	123	60									
33	20	38	95	62									

TABLE C-XI YF-16 BULKHEAD SURFACE FINISH DATA,
P/N 622-005

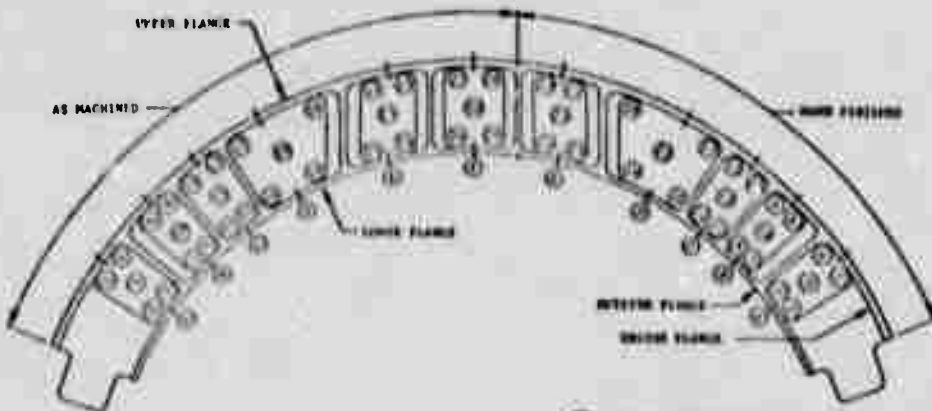

○ - WEB LOCATION
◻ - FLANGE LOCATION

POINT	WEB			
	HAND FINISH		AS MACH.	
	S/N 179	S/N 180	S/N 179	S/N 180
1	22	29	79	43
2	24	29	121	68
3	21	38	78	92
4	14	24	71	108
5	26	37	70	58
6	30	29	59	60
7	21	26	94	52
8	25	33	78	74
9	32	28	58	74
10	47	45	165	173
11	28	25	24	48
12	24	30	40	61
13	28	37	39	50
14	23	32	52	99
15	25	34	58	114
16	54	23	53	57
17	46	12	50	91
18	62	25	69	71
19	57	23	59	50
20	29	26	119	110
21	41	39	70	30
22	33	40	79	52
23	32	40	71	50
24	25	39	82	37
25	-	-	116	78
26	-	-	77	122
27	-	-	108	84
28	-	-	-	112
29	-	-	-	98
30	-	-	77	118

POINT	UPPER FLANGE				LOWER FLANGE			
	HAND FINISH		AS MACHINED		HAND FINISH		AS MACHINED	
	S/N 179	S/N 180	S/N 179	S/N 180	S/N 179	S/N 180	S/N 179	S/N 180
OUTSIDE								
A	49	29	49	19	38	34	32	37
B	42	33	40	29	37	30	39	23
C	47	33	44	42	41	24	59	37
D	41	36	32	33	38	14	38	31
E	47	25	51	34	32	14	38	20
F	-	-	28	37	-	-	48	22
INSIDE								
A	42	15	6	51	59	32	51	50
B	17	15	104	114	18	21	121	50
C	49	27	50	104	16	18	44	69
D	60	15	135	71	50	18	135	61
E	48	35	128	32	57	30	112	72
F	-	-	99	82	-	-	71	108

A P P E N D I X D
T E S T S P E C T R A A N D S T R E S S L E V E L S

PRECEDING PAGE BLANK

APPENDIX D

TABLE OF CONTENTS

	<u>Page</u>
1.0 FATIGUE TEST SPECTRA AND DESIGN STRESS LEVEL	122
2.0 TEST STRESS LEVELS	123
2.1 F-111 I-Beam Stress Levels	123
2.2 F-16 I-Beam Stress Levels	124

APPENDIX D
LIST OF TABLES

<u>Table</u>		<u>Page</u>
D-I	I-Beams - F-111 Test Spectrum	125
D-II	I-Beams - YF-16 Test Spectrum	129
D-III	YF-16 Vertical Tail Root Rolling Moment Test Spectrum	133

APPENDIX D

TEST SPECTRA AND STRESS LEVELS

This appendix describes the approach used in generating the F-111 and YF-16 wing fatigue spectra to be used on I-beams and F-111 rear spar segments as well as the YF-16 vertical tail spectrum used on the titanium fuselage frame segment that provides partial support for the YF-16 vertical tail. The selection of stress levels for these components is also discussed.

1.0 FATIGUE TEST SPECTRA AND DESIGN STRESS LEVEL

Preliminary fatigue test spectra were developed for the aluminum and titanium I-beam test program. The F-111 test spectrum shown in Table D-I was used to test the aluminum I-beam and spar specimens. The F-16 spectrum shown in Table D-II was used on aluminum and titanium I-beams. The spectrum of Table D-III was used on the YF-16 titanium frame segment. Each test spectrum represented aircraft design usage and was applied in randomized block form.

The test spectra development procedure used limited truncation of smaller load factor load level occurrences. Combined load levels (layers) were expressed as a percentage of the maximum spectrum load and randomized using an IBM 360 procedure. The randomization technique is intended to more realistically represent typical service usage for spectrum interaction effects (retardation) on crack initiation and propagation.

The 124-layer F-111 test spectrum was applied as a 200-flight-hour block. Repeating the spectrum 20 times represents one 4000-hour service life. The maximum (100%) stress level of 24 ksi is representative of the F-111 aluminum wing stress level at maximum spectrum load.

The 120-layer YF-16 test spectrum was applied as a 400-flight-hour block. Repeating the spectrum 20 times represents one 8000-hour service life. The maximum (100%) stresses of 30.7 ksi (aluminum) and 61.4 ksi (titanium) are representative of YF-16 wing stresses at maximum spectrum load.

The above stress levels were based on damage tolerance allowables analysis available at the time of spectra development. The allowables reflect the damage tolerance requirements of MIL-A-83444 (USAF Airplane Damage Tolerance requirements) for 2124-T851 aluminum slow crack growth non-inspectable structure.

2.0 TEST STRESS LEVELS

2.1 F-111 I-Beam Stress Levels

Testing of the F-111 aluminum I-beams began using the maximum spectrum stress level (MSSL) of 24 ksi. At the completion of 80 test blocks (16,000 hours) detectable cracking had not occurred. The MSSL was then increased to 45 ksi for subsequent testing in an attempt to accelerate crack initiation and yet retain sufficient inspection intervals. The 45 ksi stress was estimated based on a conventional fatigue analysis using the F-111 test spectrum.

A $K_T = 2.0$ was estimated for the web/stiffener/flange radii. The analysis combination of 45.0 ksi and $K_T = 2$ indicated that crack initiation should occur at approximately 0.5 lifetimes (10 test blocks or 2000 flight hours).

Continuation of testing at a MSSL of 45.0 ksi resulted in an unexpected failure of an I-beam in the flange at the loading fixture-to-test section area. The failure occurred during block 36 at the 45 ksi stress and was catastrophic. While the failure indicated a problem in the beam design for load transition, it was felt this could be corrected. An ultrasonic inspection of the other beams being tested at 45 ksi could find no cracks. It was decided to continue testing the other beams until 40 test blocks were completed and a fix in the problem area could be instituted. At the completion of 40 blocks, a second beam was found to have a crack in the same area that was 0.5 inches in surface length. Since the ultrasonic inspection performed on this beam during block 36 had indicated no cracking, the observation was made that the apparent crack may have formed and propagated to 0.5 inches in less than 5 blocks indicating very rapid crack growth at the 45.0 ksi stress level with very little opportunity for any practical inspection schedule to detect cracking in any area of the specimen. It was, therefore, decided that a smaller MSSL was required that would be sufficient to produce crack initiation and yet propagate crack growth at a rate that would allow detection of reasonably small cracks in less than one lifetime (or 20 test blocks).

A MSSL of 30.0 ksi was consequently selected by performing analytical crack propagation studies to establish the relative crack growth rates for the F-111 test spectrum over a range of MSSLs. The 30-ksi stress level exhibited a computed growth rate approximately 10 times slower than that of the 45-ksi stress level. The assumed crack growth behavior indicated by the second cracked beam mentioned previously (45 ksi, ultrasonically inspected after 35+ blocks, 0.5-inch crack) was approximated, and the number of blocks required to produce a 0.10-inch crack length was established as 1.8 blocks. Using the reduced analytical crack growth rate for the 30-ksi stress level, 18 blocks are estimated to produce a 0.10-inch crack size which is two blocks or 400 hours short of 1 life. The 0.10-inch crack size was judged to be a detectable size that could be polished out.

2.2 YF-16 I-Beam Stress Levels

A MSSL of 30 ksi was recommended as the starting point for the YF-16 aluminum I-beams based on the following:

- a. Analytical crack growth studies were performed for a range of MSSLs using the YF-16 test spectrum. The number of blocks required to grow a crack from 0.05" to 0.10" at 25 ksi was computed to be 38 blocks (15,200 hours). The number of F-111 blocks required to grow a crack from 0.05" to 0.10" at 24 ksi was computed to be 172 blocks (34,400 hours). Therefore, the YF-16 spectrum is about 2.26 times more severe than the F-111 spectrum.
- b. Metallurgical fractographic analysis of the catastrophic failure identified a 0.07-inch crack in the test specimen after 80 blocks (4 lives) of the F-111 spectrum testing at 24 ksi. Therefore, the YF-16 spectrum could be expected to produce an 0.07-inch crack at approximately $4/2.26 = 1.77$ lives with a MSSL of 25 ksi.
- c. The crack growth studies for the YF-16 spectrum also showed that a 30-ksi MSSL would exhibit a growth rate about 3.2 times faster than the 25-ksi MSSL. Applying this additional factor to the 1.77 lives of (b) indicated 0.5 (i.e., 1.77×3.2) lives to produce a 0.07-inch crack. It was, therefore, judged that the 30-ksi MSSL could produce cracking of the size of 0.07 to 0.10 inches in less than one lifetime.

TABLE D-I I-BEAMS - F-111 TEST SPECTRUM

<u>Load Level</u>	<u>Min %</u>	<u>Max %</u>	<u>Cycles per 200-Hr Block</u>
1	0.11	0.31	239
2	0.22	0.37	464
3	0.15	0.49	1
4	- 0.25	- 0.10	1
5	0.01	0.43	114
6	0.11	0.54	138
7	0.10	0.29	1280
8	0.05	0.60	11
9	0.00	0.59	22
10	- 0.15	- 0.07	40
11	0.21	0.93	3
12	0.11	0.77	10
13	0.32	0.77	3
14	0.19	0.79	7
15	- 0.19	0.12	832
16	0.19	0.60	810
17	0.22	0.51	112
18	- 0.02	0.24	67
19	0.19	0.76	26
20	0.10	0.38	301
21	0.18	0.37	235
22	0.05	0.32	1
23	0.01	0.42	1
24	0.32	0.78	1
25	0.15	0.69	3
26	0.26	0.65	1
27	0.29	0.71	1
28	0.18	0.47	51
29	0.06	0.47	168
30	0.15	0.59	13
31	0.21	0.85	10
32	- 0.24	- 0.07	7
33	0.11	0.65	53
34	0.25	0.61	6
35	0.02	0.47	111
36	- 0.25	- 0.15	1
37	*0.21	1.00	1
38	- 0.16	- 0.14	1
39	0.02	0.28	1376
40	0.19	0.50	18

* Maximum load level;
maximum stress = 24.0 ksi

TABLE D-I (CONTINUED)

<u>Load Level</u>	<u>Min %</u>	<u>Max %</u>	<u>Cycles per 200-Hr Block</u>
41	0.27	0.63	1
42	0.27	0.54	10
43	0.18	0.44	20
44	0.02	0.38	362
45	0.10	0.37	178
46	0.10	0.28	1546
47	0.19	0.46	321
48	0.19	0.40	381
49	0.22	0.47	180
50	0.10	0.32	6
51	0.15	0.31	5
52	- 0.21	- 0.13	4
53	0.27	0.59	18
54	0.28	0.64	50
55	0.22	0.46	352
56	- 0.22	- 0.12	1
57	0.19	0.74	97
58	0.01	0.46	102
59	0.13	0.34	291
60	0.19	0.49	278
61	0.15	0.40	3
62	0.32	0.58	11
63	0.08	0.35	477
64	0.10	0.43	35
65	0.01	0.29	1374
66	0.21	0.72	30
67	0.21	0.62	543
68	- 0.21	- 0.05	17
69	0.25	0.56	81
70	0.21	0.42	686
71	- 0.02	0.44	63
72	0.21	0.45	130
73	0.02	0.56	102
74	0.21	0.69	1
75	- 0.21	0.04	476
76	0.19	0.48	989
77	0.19	0.83	1
78	0.19	0.47	416

TABLE D-I (CONTINUED)

<u>Load Level</u>	<u>Min %</u>	<u>Max %</u>	<u>Cycles per 200-Hr Block</u>
79	- 0.24	0.03	15
80	0.32	0.69	8
81	0.28	0.70	4
82	0.19	0.44	505
83	0.19	0.37	763
84	0.21	0.66	104
85	- 0.02	0.53	19
86	0.19	0.72	280
87	0.19	0.52	147
88	0.01	0.37	371
89	- 0.02	- 0.06	128
90	- 0.21	0.07	557
91	0.21	0.66	4
92	- 0.17	0.07	50
93	0.21	0.56	75
94	0.19	0.68	533
95	- 0.17	- 0.12	2
96	- 0.25	- 0.18	2
97	0.21	0.54	682
98	- 0.21	0.04	295
99	0.15	0.49	25
100	0.11	0.42	193
101	0.21	0.70	15
102	0.08	0.35	13
103	0.21	0.64	195
104	0.10	0.46	29
105	- 0.07	0.61	1
106	0.01	0.42	11
107	0.01	0.37	38
108	0.21	0.99	1
109	0.10	0.47	64
110	- 0.26	- 0.19	1
111	- 0.25	0.10	200
112	0.15	0.39	32
113	0.10	0.56	19
114	- 0.08	0.17	238
115	- 0.06	0.48	1
116	0.10	0.44	1
117	0.29	0.62	12
118	0.00	0.32	300
119	0.0	0.04	266

TABLE D-I (CONTINUED)

<u>Load Level</u>	<u>Min %</u>	<u>Max %</u>	<u>Cycles per 200-Hr Block</u>
120	- 0.21	- 0.09	6
121	0.11	0.87	2
122	0.10	0.53	1
123	0.18	0.42	37
124	0.10	0.59	1

Total cycles per block = 22,424

TABLE D-II I-BEAMS - YF-16 TEST SPECTRUM

<u>Load Level</u>	<u>Min. %</u>	<u>Max. %</u>	<u>Cycles per 400-Hr Block</u>
1	0.10	0.42	847
2	0.15	0.55	5
3	0.12	0.44	21
4	0.15	0.95	1
5	0.13	0.51	2
6	- 0.03	0.44	2
7	0.14	0.34	1861
8	0.15	0.83	4
9	0.11	0.30	187
10	0.15	0.65	7
11	0.13	0.49	3
12	0.13	0.44	9
13	- 0.04	0.10	22
14	0.10	0.27	18
15	0.12	0.57	37
16	0.15	0.36	102
17	- 0.03	1.00*	1
18	0.11	0.30	1460
19	0.15	0.79	4
20	0.13	0.27	38
21	- 0.03	0.67	13
22	0.15	0.41	93
23	0.15	0.51	39
24	0.12	0.46	3
25	0.15	0.58	1
26	- 0.06	0.15	36
27	0.11	0.35	24
28	0.15	0.51	318
29	0.15	0.48	43
30	0.10	0.30	1271
31	0.13	0.30	111
32	0.16	0.51	24
33	0.13	0.51	1
34	0.15	0.58	2
35	- 0.03	0.72	16

* Maximum Load Level; Maximum Stress = 30.7 ksi (Aluminum) and 61.4 ksi (Titanium).

TABLE D-II (CONTINUED)

<u>Load Level</u>	<u>Min. %</u>	<u>Max. %</u>	<u>Cycles per 400-hr Block</u>
36	0.13	0.38	1
37	0.12	0.52	1
38	0.10	0.60	68
39	0.07	0.38	51
40	0.15	0.57	15
41	0.13	0.32	164
42	0.15	0.58	3
43	0.13	0.34	72
44	0.15	0.54	26
45	0.11	0.44	3
46	0.15	0.36	65
47	0.12	0.81	1
48	0.12	0.64	10
49	0.12	0.68	8
50	0.15	0.57	10
51	0.12	0.72	4
52	0.11	0.35	1122
53	0.15	0.44	34
54	0.14	0.68	164
55	0.12	0.51	44
56	0.12	0.51	3
57	0.15	0.34	347
58	0.13	0.34	5
59	0.0	0.15	57
60	- 0.23	0.12	4
61	0.12	0.54	1
62	0.11	0.32	65
63	0.12	0.47	30
64	0.12	0.44	43
65	- 0.03	0.59	31
66	0.15	0.48	8
67	0.12	0.51	26
68	0.15	0.38	477
69	0.11	0.30	889
70	0.07	0.62	4
71	0.12	0.33	30
72	0.12	0.78	1
73	0.15	0.48	1
74	0.10	0.49	1
75	0.13	0.41	10

TABLE D-II (CONTINUED)

<u>Load Level</u>	<u>Min. %</u>	<u>Max. %</u>	<u>Cycles per 400-Hr Block</u>
76	0.13	0.49	55
77	0.15	0.41	111
78	- 0.03	0.53	91
79	0.12	0.37	86
80	0.15	0.44	16
81	0.12	0.72	1
82	0.11	0.35	12
83	0.16	0.65	2
84	0.12	0.37	69
85	0.12	0.30	347
86	0.10	0.49	313
87	- 0.03	0.84	7
88	- 0.02	0.13	66
89	0.12	0.64	2
90	0.07	0.50	19
91	0.15	0.38	69
92	- 0.13	0.15	12
93	0.12	0.41	305
94	0.14	0.52	314
95	0.12	0.57	1
96	0.13	0.41	187
97	0.13	0.41	1259
98	0.14	0.54	1
99	0.13	0.32	924
100	0.12	0.30	57
101	- 0.03	0.92	1
102	0.10	0.38	5
103	- 0.03	0.62	13
104	0.15	0.78	30
105	0.11	0.44	463
106	0.14	0.33	1380
107	0.15	0.59	143
108	0.15	0.41	87
109	0.15	0.38	138
110	0.14	0.45	1109
111	0.12	0.72	2
112	- 0.10	0.12	23

TABLE D-II (CONTINUED)

<u>Load Level</u>	<u>Min. %</u>	<u>Max. %</u>	<u>Cycles per 400-Hr Block</u>
113	0.13	0.53	608
114	0.07	0.26	77
115	- 0.16	0.12	8
116	0.12	0.58	9
117	0.12	0.64	4
118	0.15	0.54	33
119	0.15	0.58	281
120	- 0.03	0.76	2

Total cycles per block = 19,305

TABLE D-III
YF-16 VERTICAL TAIL ROOT ROLLING MOMENT TEST SPECTRUM

Load Level	Min. Percent Alt. Load	Max. Percent Alt. Load	Cycles per Block
1	- 25.0	25.0	2900
2	- 83.3	83.3	1
3	- 100.0	100.0	One Cycle Every 5 Blocks
4	- 41.7	41.7	89
5	- 66.7	66.7	4
6	- 58.3	58.3	9
7	- 75.0	75.0	2
8	- 33.3	33.3	470
9	- 16.7	16.7	14500
10	- 91.7	91.7	One Cycle Every 2 Blocks
11	- 50.0	50.0	25

NOTES: (1) The mean load is zero.

(2) 1 Block = 400 flight hours.

(3) 100% root RM @ W.L. 116.5 = 0.600×10^6 in. lbs.

A P P E N D I X E
TEST FIXTURES AND SPECIMEN LOADING

PRECEDING PAGE BLANK

APPENDIX E
TABLE OF CONTENTS

	<u>Page</u>
1.0 TEST FIXTURES	139
1.1 I-Beams	139
1.2 F-111 Rear Spar Segments	139
1.3 YF-16 Fuselage Frame	139
2.0 LOADING SYSTEM	144
3.0 PROCEDURES	144
3.1 Strain Surveys	144
3.2 Inspections	155
4.0 I-BEAM FATIGUE TESTS	155
4.1 Test Procedure Variations	160
4.2 I-Beam Orientation	160
5.0 FATIGUE TEST SPECTRA	164

APPENDIX E

LIST OF ILLUSTRATIONS

<u>Figure</u>		<u>Page</u>
E-1	I-Beam Test Loading Arrangement	140
E-2	F-111 Inboard Rear Spar Segment Loading Arrangement	141
E-3	F-111 Outboard Rear Spar Segment Loading Arrangement	142
E-4	YF-16 Titanium Frame Loading Arrangement	143
E-5	I-Beam - Strain Gauge Locations (622-010)	154
E-6	F-111 Inboard Rear Spar Segment - Strain Gauge Locations (622-012)	156
E-7	F-111 Outboard Rear Spar Segment - Strain Gauge Locations (622-014)	157
E-8	YF-16 Fuselage Frame Strain Gauge Locations (622-013)	158
E-9	Doubler - Aluminum I-Beam (622-015)	161
E-10	1/4 Inch Diameter Holes - Aluminum I-Beams	162
E-11	I-Beam Orientation	163

APPENDIX E
LIST OF TABLES

<u>Table</u>		<u>Page</u>
E-I	Final Strain Survey on First I-Beam Specimen	145
E-II	Final Strain Data on the F-111 Inboard Rear Spar Specimen	148
E-III	Final Strain Data on the F-111 Outboard Rear Spar Specimen	150
E-IV	Final Strain on the YF-16 Frame Segment	151
E-V	Final Strain Readings for I-Beam Load Balance	153
E-VI	Test Inspection Schedule	159

APPENDIX E

TEST FIXTURES AND SPECIMEN LOADING

This appendix describes the test set-up and the operations pertinent to the fatigue spectrum loading on the I-beams, the F-111 rear spar segments and the YF-16 fuselage frame.

1.0 TEST FIXTURES

Each specimen type was installed in a test fixture specially designed to apply its loading requirements.

1.1 I-Beams

The I-beam specimens were installed in fixture 622FTJ21812 as shown in Figure E-1. This fixture applied fixed end moments to the specimen so the stress was constant along the length of the beam test section. Four beams with loading assemblies were suspended from a support frame and were tested simultaneously.

1.2 F-111 Rear Spar Segments

The rear spar specimens were installed in fixture 622FTJ21820 as shown in Figures E-2 and E-3. The rear spars were loaded in pairs consisting of one as-machined and one hand-finished part. The loading assembly applied fixed end moments to each of the two pairs of spars suspended in the fixture.

1.3 YF-16 Fuselage Frame

The YF-16 fuselage frame specimen consisted of two sculptured channels back to back, half of each channel as-machined, the other half hand-finished. The assembly was installed in a loading frame as shown in Figure E-4. The test fixture is specified on drawing 622FTJ21825. The loads were applied through a fitting representing the vertical tail attach fitting and were completely reversible.

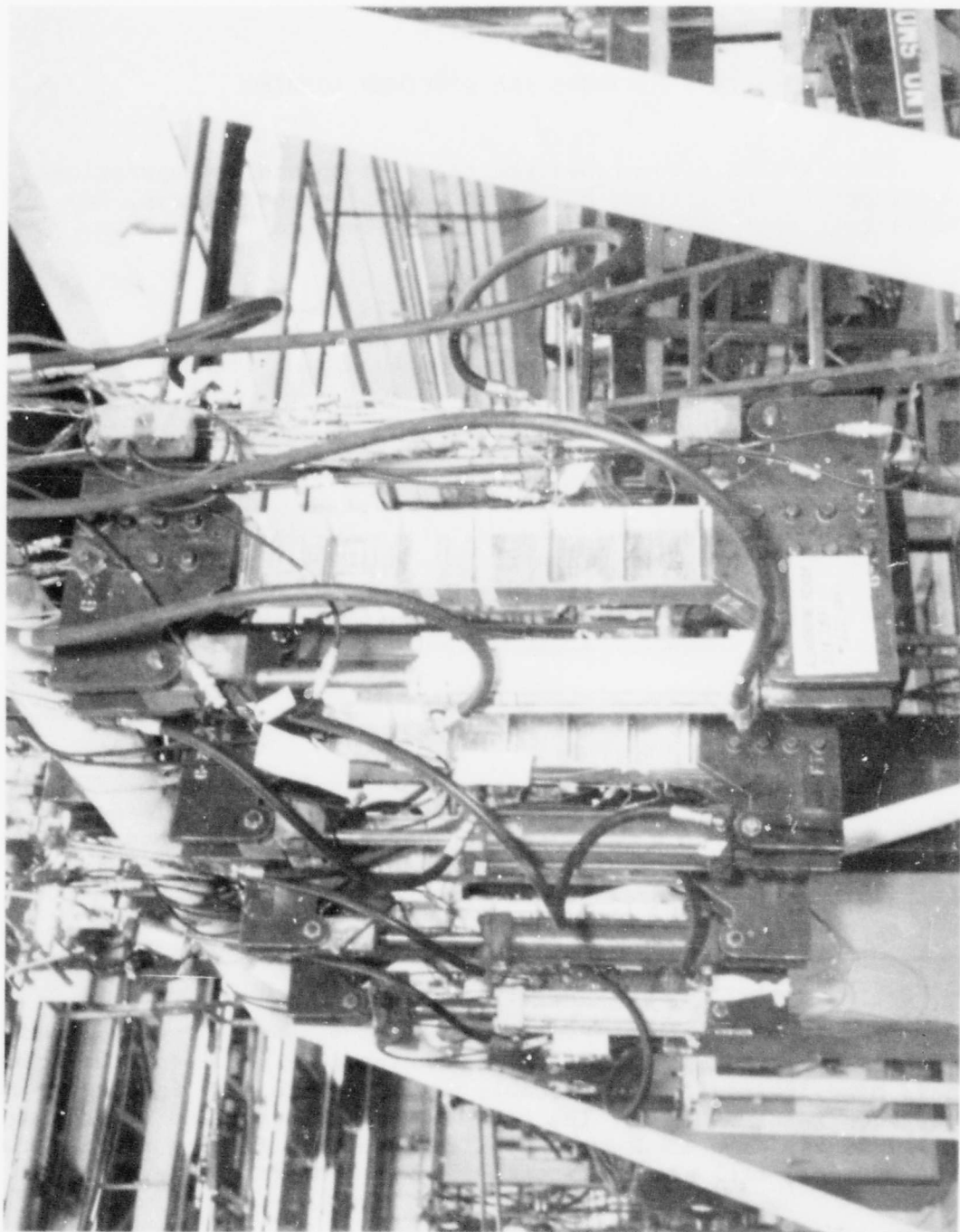

FIGURE E-1 I-BEAM TEST LOADING ARRANGEMENT

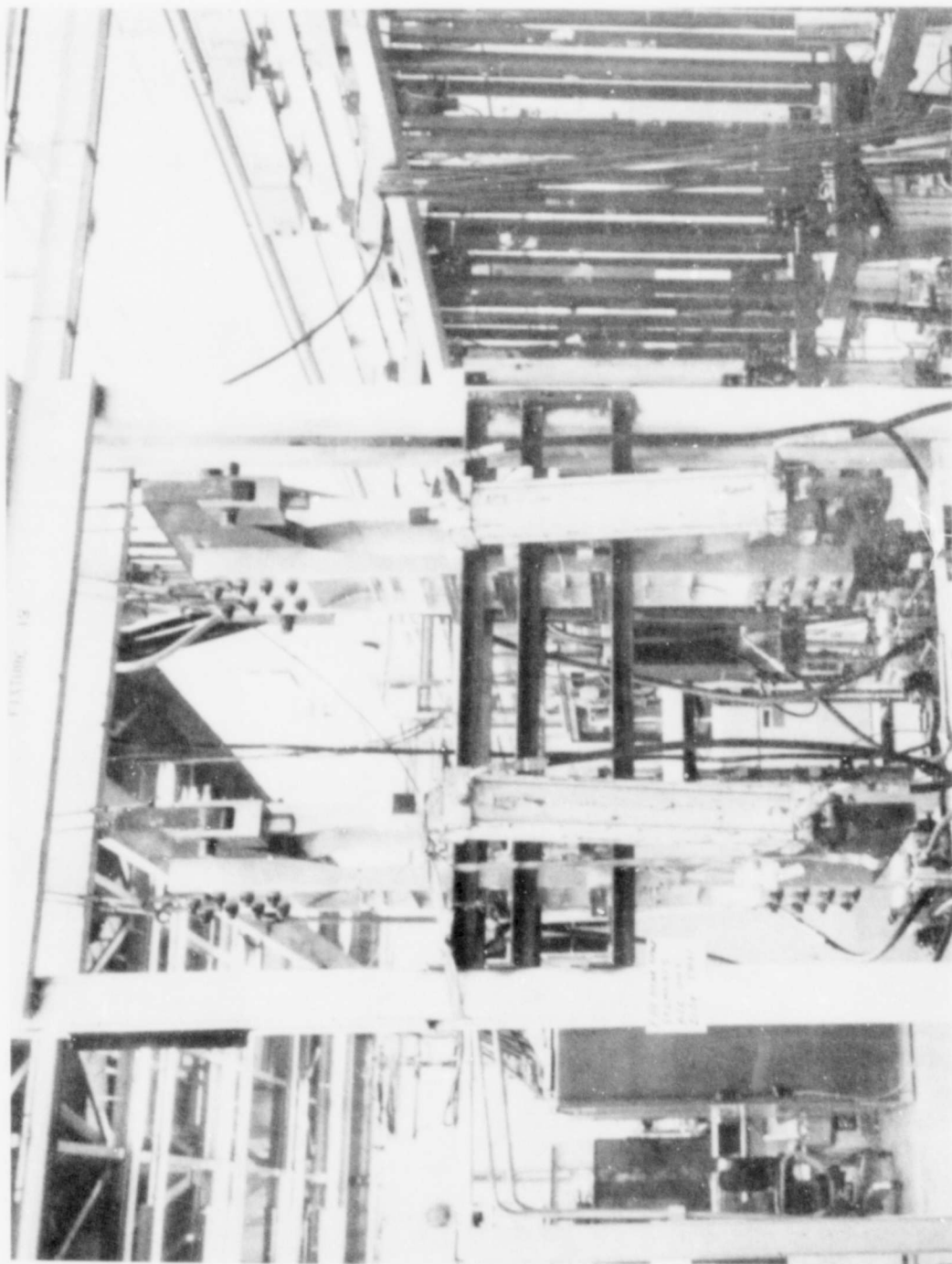

FIGURE E-2

FIGURE E-2 F-111 INBOARD REAR SPAR SEGMENT LOADING ARRANGEMENT

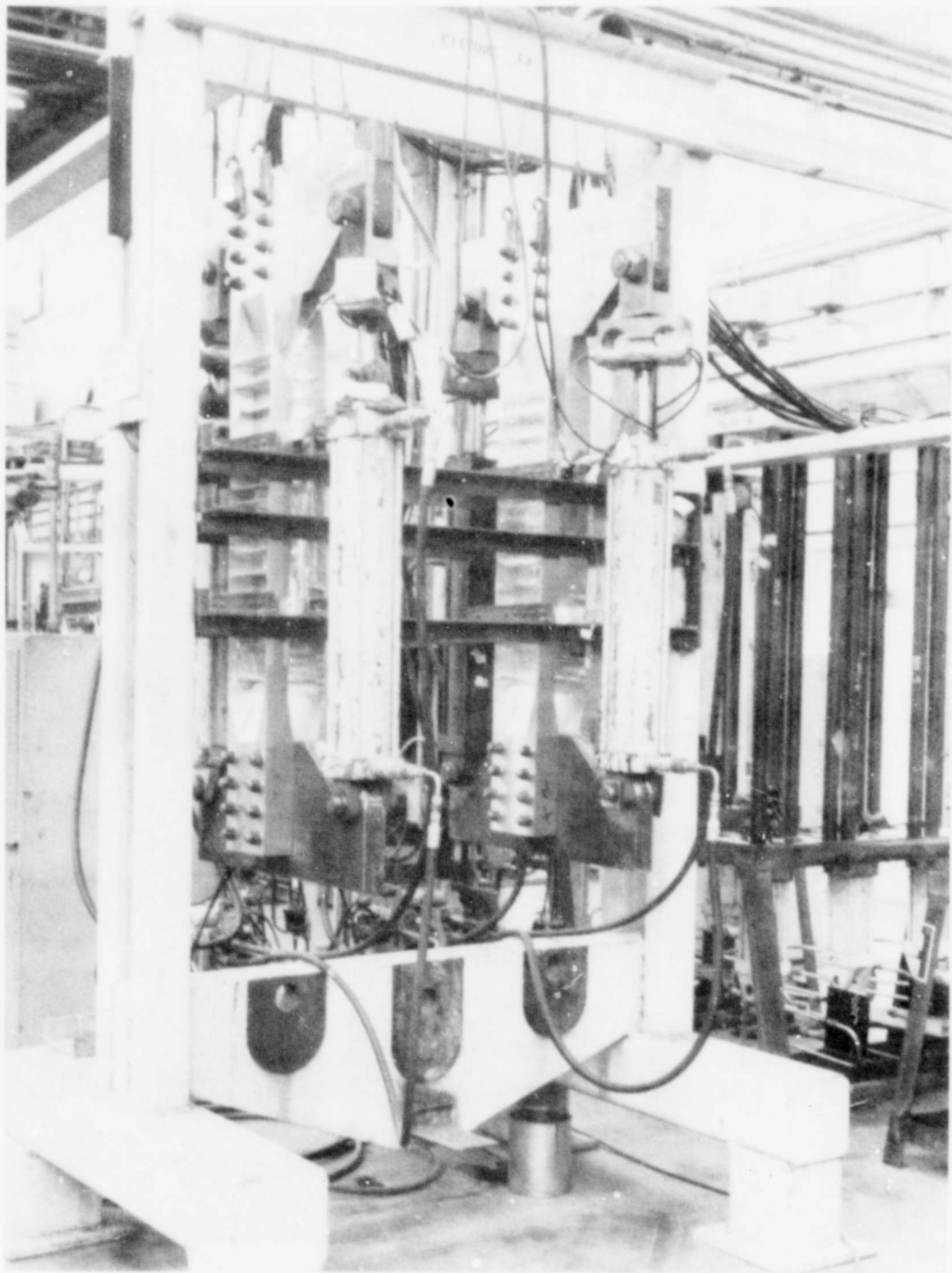

FIGURE E-3 F-111 OUTBOARD REAR SPAR SEGMENT LOADING ARRANGEMENT

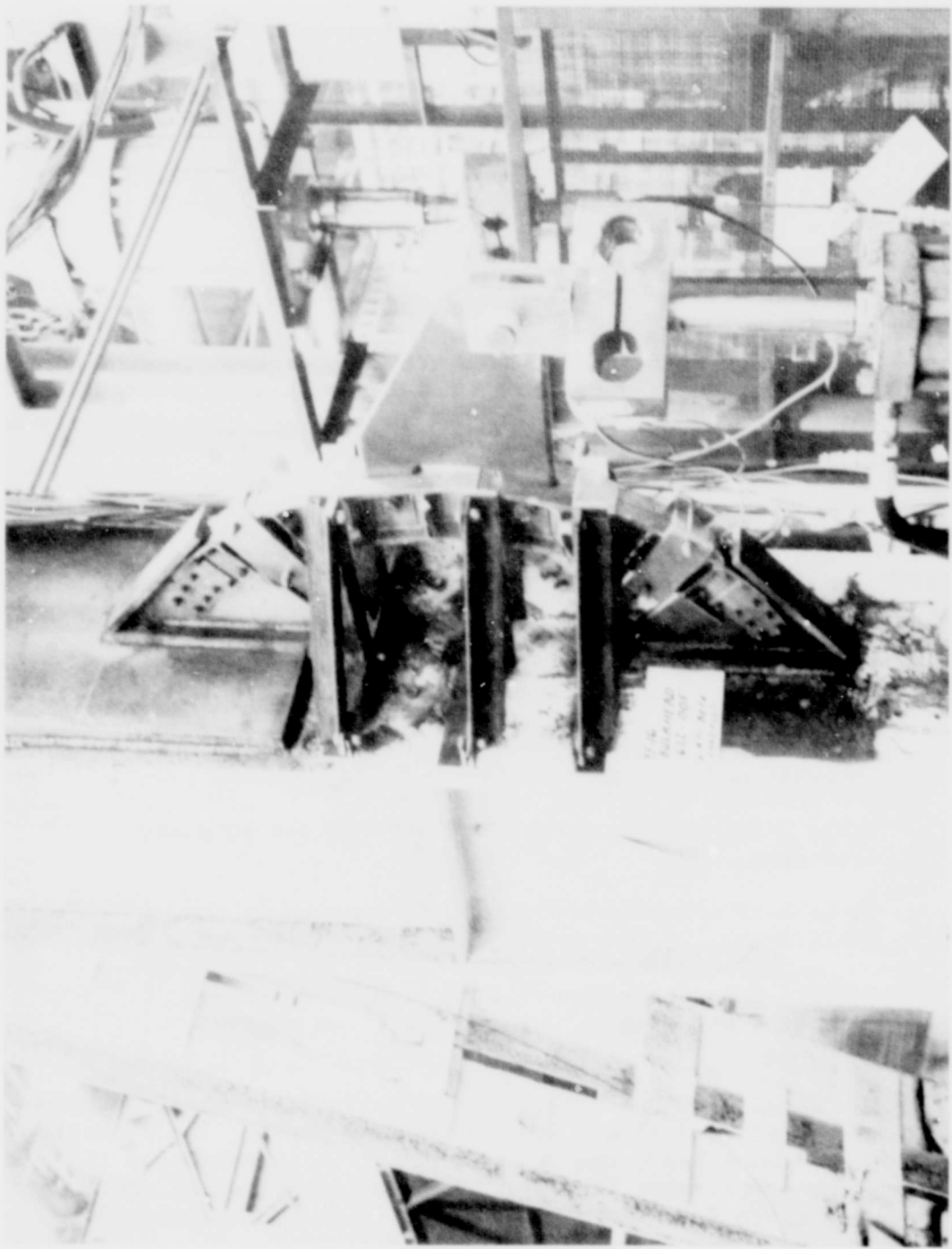

FIGURE E-4 YF-16 TITANIUM FRAME LOADING ARRANGEMENT

2.0 LOADING SYSTEM

The load control system for this program was the computerized, electro-hydraulic servo system with load cell feed back closing the loop. The spectrum data was stored in computer memory as digital data. Each layer or step was called up sequentially and converted to an analog signal which was the command signal for the closed loop servo system. Each specimen was controlled by its individual command channel.

3.0 PROCEDURES

The procedures discussed here are those common to each specimen. Procedures peculiar to the I-Beams are discussed in Section 4.

3.1 Strain Surveys

Strain surveys were conducted on each type of specimen before the application of spectrum fatigue loading and are reported in Tables E-I thru E-V.

Table E-I presents the final strain survey on the first I-beam.

Table E-II presents the final strain survey on the inboard read spar.

Table E-III presents the final data on the outboard read spar.

Table E-IV presents the final strain data on the YF-16 frame.

Table E-V presents the final strain readings for balancing each I-beam prior to spectrum fatigue loading.

The first aluminum I-beam had 80 channels of strain gauges to verify predicted stress levels and load paths. The remaining I-beam specimens had 8 channels of gauges which were used to verify the symmetry of the applied loads. Location of gauges are shown on Figure E-5. Adjustment capabilities for aligning the load rams were incorporated in the load fixture. The adjustments were made until the symmetry of the strain readings was within 5% of the theoretical strain.

10-0292 TOLERANCE CONCEPTS TABLE E-I FINAL STRAIN SURVEY ON FIRST I-BEAM SPECIMEN
 RELAXED ALUMINUM I-BEAM

DRAWING NO.	CHAN NO.	IDENT	TIME		1104:102	1104:41	1105:17	1105:52	1106:29	1106:59	LEAST SQUARES
			INCREMENT % LOAD								
15K-13R-39	18	LOAD 1			1	2	3	4	5	6	5674
15K-13R-74	19	LOAD 2			20	40	60	80	100	0	-5750
					LOAD, LB 1132 -1114	2274 -2248	3399 -3434	4518 -4579	5689 -5758	19 8	
					STRESS, PSI						
622-001	20	1			-2967	-6336	-10194	-13998	-17954	-54	-17817
622-001	21	2			-4139	-8290	-12603	-16819	-21197	-54	-21139
622-001	22	3			-4539	-8916	-13303	-17571	-22001	-54	-21982
622-001	23	4			-4713	-8904	-12715	-16397	-20164	-11	-20258
622-001	24	5			-3575	-7747	-12538	-17308	-22273	-22	-22080
622-001	25	6			-4876	-9893	-15094	-20220	-25509	27	-25437
622-001	26	7			-5083	-10004	-14826	-19573	-24444	0	-24447
622-001	27	8			-6279	-11905	-16957	-21943	-26994	119	-27109
622-001	28	9			4911	10006	15048	20067	25130	65	25132
622-001	29	10			5347	10759	16225	21691	27288	-22	27225
622-001	30	11			4673	9345	14159	18984	23950	43	23860
622-001	31	12			4865	9568	14553	19570	24794	22	24642
622-001	32	13			3930	8012	12040	16056	20138	43	20127
622-001	33	14			4312	8679	13047	17422	21952	-54	21891
622-001	34	15			4391	8804	13303	17814	22498	43	22407
622-001	35	16			3853	7641	11625	15630	19863	11	19724
622-001	36	17			-3519	-7493	-11816	-16247	-20830	-11	-20656
622-001	37	18			-4673	-9195	-13608	-18032	-22586	0	-22552
622-001	38	19			-4261	-8523	-12915	-17296	-21840	33	-21753
622-001	39	20			-5472	-10380	-14941	-19381	-23974	11	-24031
622-001	40	21			-3313	-7058	-11353	-15615	-20051	130	-19885
622-001	41	22			-4665	-9395	-14341	-19158	-24169	97	-24100
622-001	42	23			-4849	-9536	-14213	-18716	-23414	32	-23408
622-001	43	24			-5535	-10456	-14987	-19314	-23792	54	-23891
622-001	44	25			4320	8834	13392	17842	22421	54	22403
622-001	45	26			4800	9654	14648	19545	24625	0	24562
622-001	46	27			4969	9884	14994	20038	25268	11	25193
622-001	47	28			4837	9522	14667	19401	24583	0	24436
622-001	48	29			4556	9209	13808	18343	22974	-22	22972
622-001	49	30			4491	9014	13613	18147	22832	-11	22783
622-001	50	31			4393	8808	13341	17842	22516	-11	22436
622-001	51	32			4437	8787	13347	17953	22767	0	22634
622-001	52	33			-3919	-8248	-12966	-17706	-22640	-43	-22475
622-001	53	34			-3833	-7807	-12029	-16241	-20625	-86	-20511

TABLE E-I (Cont'd)

10-0292
 RELAXED TOLERANCE CONCEPTS
 ALUMINUM I-BEAM

DRAWING NO.	CHAN NO.	IDENT	TIME		1104:02	1104:41	1105:17	1105:52	1106:29	1106:59	LEAST SQUARES				
			INCREMENT	LOAD											
			1	20		2	40	3	60	4	80	5	100	6	100
622-001	54	35	STRESS, PSI												
622-001	55	36	-4180	-8359	-12625	-16826	-21190	-76	-21133						
622-001	56	37	-4689	-9108	-13365	-17515	-21773	-43	-21805						
622-001	57	38	-4086	-8398	-13076	-17679	-22444	388	-22336						
622-001	58	39	-4820	-9629	-14643	-19550	-24650	-32	-24575						
622-001	59	40	-5571	-10722	-15647	-20421	-25335	0	-25385						
622-001	60	41	4573	9307	14149	18884	23748	32	23718						
622-001	61	42	4637	9316	14135	18847	23741	21	23683						
622-001	62	43	5192	10191	15383	20511	25864	11	25761						
622-001	63	44	4326	8717	13140	17488	21954	64	21930						
622-001	64	45	4347	8715	13180	17623	22185	-43	22127						
622-001	64	45	4240	8470	12904	17359	21953	0	21848						
622-001	65	46A	STRESS, PSI												
622-001	66	46B	-90	-191	-326	-450	-60A	0	-592						
622-001	67	46C	-22	-11	45	79	112	11	112						
			56	112	259	337	472	0	459						
			-87.8	84.7	82.5	80.5	80.8	45.0							
			30	57	177	229	327	8	317						
			-80	-175	-278	-397	-529	-8	-516						
			55	116	228	313	428	8	416						
622-001	68	47	STRESS, PSI												
622-001	69	48	-4197	-8480	-12677	-16960	-21329	-21	-21278						
622-001	70	49	-4165	-8405	-12581	-16789	-21082	11	-21048						
622-001	71	50	4036	8298	12732	17144	21685	11	21608						
622-001	72	51	4520	8932	13301	17659	22190	-11	22134						
622-001	73	52	-5616	-10662	-15118	-19564	-24127	11	-24202						
622-001	74	53	-3188	-7073	-11495	-15928	-20500	11	-20332						
622-001	75	54	4070	8237	12844	17365	22058	-11	21935						
622-001	76	55	4872	9604	14218	18714	23382	-21	23384						
622-001	77	56	-5291	-9810	-13942	-17892	-22002	-21	-22088						
622-001	78	57	-4471	-8749	-13070	-17220	-21541	0	-21533						
622-001	79	58	-3979	-8012	-12303	-16422	-20712	-32	-20661						
622-001	80	59	-2767	-6231	-10348	-14327	-18477	-11	-18333						
622-001	81	60	-6289	-11759	-16648	-21376	-26286	108	-26394						
622-001	82	61	-5156	-10173	-15114	-19969	-24964	22	-24957						
622-001	82	61	-4068	-8383	-12893	-17380	-21975	0	-21902						

PAGE 3
 DATE 11-19-74
 RUN NO. 01
 CONDITION 14

TABLE E-I (Cont'd)

10-0292
 RELAXED TOLERANCE CONCEPTS
 ALUMINUM I-BEAM

DRAWING NO.	CHAN NO.	IDENT	TIME		1104:02	1104:41	1:05:17	1105:52	1106:29	1106:59	LEAST SQUARES
			INCREMENT	% LOAD							
			1	2	1104:02	1104:41	1:05:17	1105:52	1106:29	1106:59	
			20	40			3	60	5	100	100
					STRESS, PSI						
622-001	83	62	-2971	-6835	-11431	-16005	-20741	-20741	75	-20539	
622-001	84	63	4500	9033	13996	18830	23794	23794	32	23707	
622-001	85	64	4820	9716	14827	19840	25027	25027	-22	24953	
622-001	86	65	5047	10148	15292	20361	25591	25591	22	25548	
622-001	87	66	5261	10480	15461	20346	25371	25371	54	25401	
622-001	88	67	3702	7501	11698	15809	20092	20092	11	19978	
622-001	89	68	4101	8278	12637	16910	21356	21356	11	21285	
622-001	90	69	4282	8574	12974	17277	21742	21742	22	21694	
622-001	91	70	4456	8890	13195	17414	21783	21783	22	21783	
622-001	92	71	-4074	-8298	-12852	-17332	-22014	-22014	-53	-21897	
622-001	93	72	-5075	-9840	-14499	-18977	-23604	-23604	0	-23638	
622-001	94	73	4552	9199	13986	18623	23430	23430	32	23394	
622-001	95	74	4707	9287	14101	18819	23771	23771	-75	23669	
622-001	96	75	-5366	-10273	-14902	-19425	-24087	-24087	-21	-24130	
622-001	97	76	-3628	-704	-12239	-16657	-21223	-21223	-32	-21123	
622-001	98	77	4309	8736	13536	18219	23061	23061	32	22969	
622-001	99	78	4797	9574	14264	18923	23699	23699	-21	23682	

TABLE E-III FINAL STRAIN DATA ON THE F-111 OUTBOARD REAR SPAR SPECIMEN

10-049.
 FLEXURE TOLERANCE CONCEPTS
 OUTBOARD REAR SPAR

DOWEL NO.	CHAN NO.	IDENT	TIME		1353:54	1354:43	1355:29	1356:04	1357:03	1357:40	LEAST SQUARES
			INCREMENT	LOAD							
304-134-34	18	LOAD 1			1	2	3	4	5	6	9510
304-134-16	19	LOAD 2			20	40	60	80	100	0	-9709
					LOAD, LB	3724	5679	7614	9486	-140	
					1F22	-3951	-5905	-7814	-9682	-53	
					2032						
					STRESS, PSI						
20	1				5545	10610	15729	20773	25444	-32	25759
21	2				4107	8640	13387	18101	22752	-85	22747
22	3				6142	11763	17427	23015	28497	-64	28561
23	4				4412	9292	14450	19623	24733	-197	24494
24	5				-5513	-10631	-15701	-20843	-25793	331	-25487
25	6				-4877	-9647	-14513	-19315	-23903	124	-23995
26	7				-5430	-10490	-15542	-20652	-25554	158	-25625
27	8				-5471	-10205	-16277	-21574	-26481	116	-26490
28	9				5454	10517	15621	20702	25567	-43	25716
29	10				4532	9235	14097	19017	23452	-25	23671
30	11				6016	11637	17312	22943	28426	-43	28442
31	12				4052	8572	13339	18095	22776	-107	22761
32	13				-5501	-11452	-17105	-22564	-27939	434	-28110
33	14				-4950	-9750	-14649	-19544	-24247	117	-24321
34	15				-5442	-10567	-15764	-20559	-25214	190	-25292
35	16				-5567	-10840	-16280	-21644	-26844	106	-26907
36	17				2794	5617	8507	11372	14159	-32	14115
37	18				4775	9603	14524	19345	24075	-42	24151
38	19				-3333	-6613	-9930	-13143	-16263	95	-16344
39	20				-4407	-8624	-12674	-16674	-20605	137	-20622
40	21				3220	6117	12459	17114	21495	-32	21504
41	22				4735	9248	13833	18324	22687	-11	22752
42	23				4440	8495	12765	16984	20662	-21	20628
43	24				6040	11602	17194	22695	28056	-11	28143
44	25				-4836	-10046	-15469	-20776	-25922	160	-25990
45	26				-6007	-11854	-17765	-23503	-28997	180	-29152
46	27				-4141	-8654	-13369	-18009	-22501	106	-22550
47	28				-4722	-9486	-14324	-19035	-23556	159	-23568
48	29				2771	5531	8387	11179	13914	-21	13945
49	14-2				5051	9931	14904	19774	24500	-21	24542
50	15-2				-3300	-6631	-9945	-13262	-16403	106	-16444
51	20-2				-5047	-10233	-15594	-20942	-26117	127	-26157

TABLE E-IV FINAL STRAIN ON YF-16 FRAME SPECIMEN

10-0292
 RELAXED TOLERANCE CONCEPTS
 YF16 BULKHEAD

DRAWING NO.	CHAN NO.	IDENT	TIME		1349:49	1350:06	1350:22	1350:38	1350:53	1351:12	FACT SQUARES
			INCREMENT % LOAD								
50Y-2-12-B	139	LOAD			LOAD, LB 5207	11882	17925	24022	30505	0	30336
622-005	140	1			STRESS, PSI -80	-335	-972	-1801	-2901	-64	-2640
622-005	141	2			-589	-1338	-1724	-2114	-2341	0	-2491
622-005	142	3			-2024	-4223	-6725	-9275	-12223	239	-11924
622-005	143	4			-2863	-4994	-6934	-8954	-11355	207	-11269
622-005	144	5			-5044	-12514	-18935	-25262	-32457	-64	-32169
622-005	145	6			-9224	-15685	-23901	-30284	-38063	-64	-37907
622-005	146	7			6564	11372	16043	20651	25267	-32	25325
622-005	147	8			5539	10103	15354	20796	26653	271	26274
622-005	148	9			607	1007	1231	1439	1870	54	1822
622-005	149	10			1843	7476	38213	84189	136283	329251	122719
622-005	150	11			930	2714	4363	5636	6722	-112	6900
622-005	151	12			0	1182	2172	3226	4391	80	4350
622-005	152	13			8204	16440	23744	30608	37213	-48	37543
622-005	153	14			7665	16175	23409	30387	37684	48	37914
622-005	154	15			-1214	-1646	-2237	-3069	-4314	-224	-4020
622-005	155	16			-3162	-4296	-5941	-7507	-9231	-16	-9057
622-005	156	17			414	1747	2982	3765	4755	-48	4758
622-005	157	18			-32	240	671	1310	2149	112	1048
622-005	158	19			1772	3352	4884	6672	8715	96	8520
622-005	159	20			1555	3026	4349	5835	7642	-320	7418
622-005	160	21			1945	3826	5369	6848	8697	113	8642
622-005	161	22			3237	5192	4983	4278	3461	-160	4137

TABLE E-V
FINAL STRAIN READINGS FOR
I BEAM LOAD BALANCE

SPECIMEN S/N	STRAIN IN μ IN./IN. @ 50% APPLIED LOAD									
	GAGE NO.									
	71	72	73	74	75	76	77	78		
F409755	-1100	-1100	+1055	+1170	-1100	-1070	+1125	+1065		
F409764	-1040	-1070	+1085	+1085	-1040	-1040	+1075	+1075		
F409759	-1010	-1130	+1140	+1020	-1090	-1070	+1050	+1130		
F409758	-1080	-1050	+1080	+1040	-1075	-1055	+1020	+1090		
F409762	-2060	-1960	+1960	+2180	-2100	-1900	+2060	+2030		
F409757	-1320	-1420	+1370	+1410	-1470	-1290	+1380	+1410		
F409765	-1310	-1360	+1440	+1300	-1290	-1360	+1350	+1400		
F409760	-1460	-1550	+1600	+1500	-1470	-1540	+1545	+1545		
F409768	-2420	-2340	+2450	+2360	-2390	-2400	+2370	+2490		
F409767	-2840	-2940	+2870	+2920	-2950	-2850	+2760	+2850		
F409771	-2900	-2880	+2890	+2850	-2760	-2840	+2780	+2790		
F409772	-2730	-2700	+2750	+2760	-2810	-2710	+2870	+2800		
F409769	-2880	-2970	+2950	+2960	-2860	-2850	+2880	+2940		
F409770	-2000	-2060	+2100	+2120	-2300	-1940	+2060	+2080		
F409761	-1190	-1270	+1230	+1180	-1370	-1110	+1200	+1290		
F409763	-1200	-1240	+1250	+1220	-1250	-1180	+1230	+1235		
F409766	-1260	-1290	+1270	+1290	-1300	-1210	+1280	+1280		
F411316	-1240	-1190	+1220	+1230	-1190	-1220	+1200	+1240		

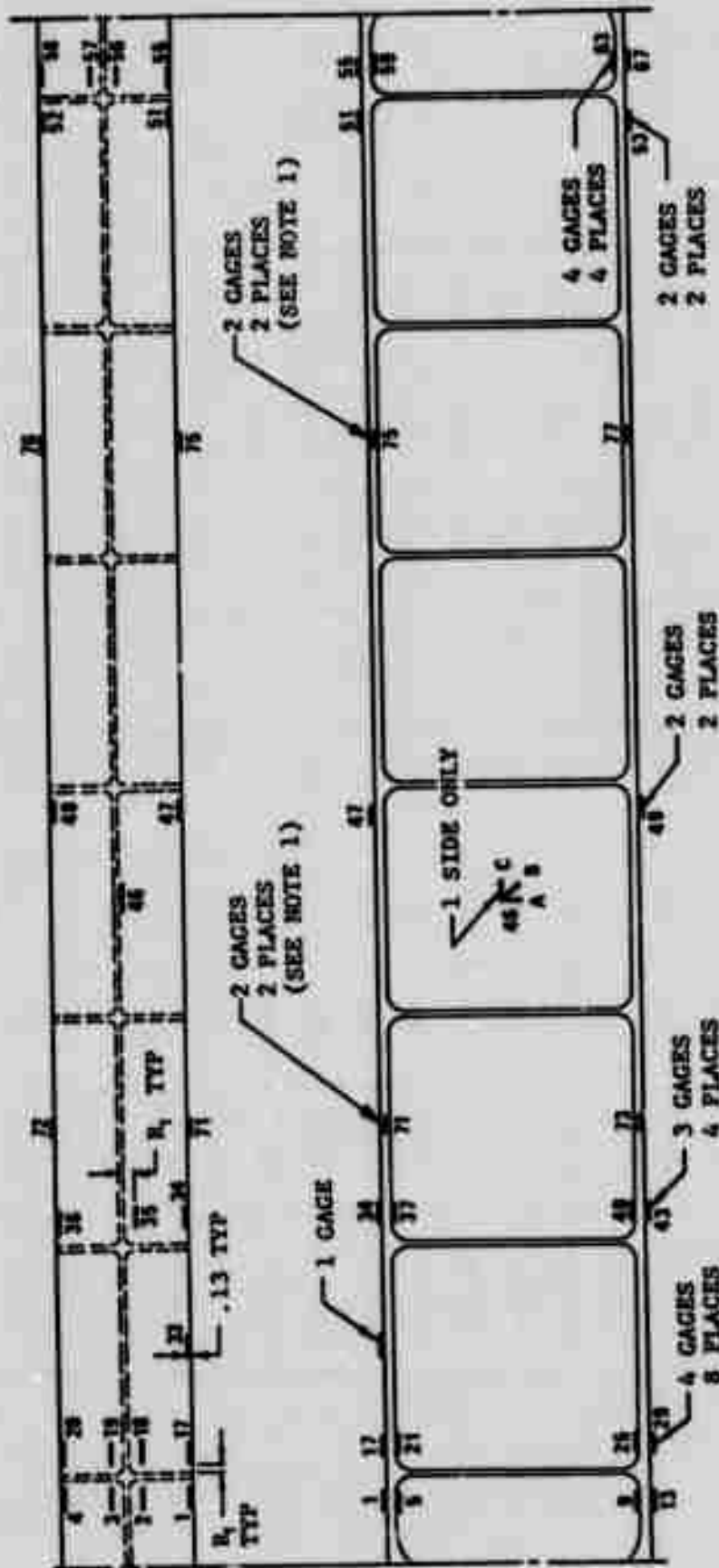

- NOTES:
- EIGHT (8) GAGES AT NOTED LOCATIONS TO BE ON ALL SPECIMENS.
ALL OTHER GAGES TO BE ON FIRST 622-001 & FIRST 622-002 SPECIMENS ONLY.
 - NO. OF CHANNELS: 80 ON FIRST SPECIMENS, 8 ON ALL OTHERS.

FIGURE E-5 I-BEAM - STRAIN GAUGE LOCATIONS (622-010)

One each of the F-111 inboard and outboard rear spar specimens was instrumented with 27 and 28 channels of strain gauges, respectively, as shown in Figures E-6 and E-7. The remaining inboard and outboard specimens had 7 and 4 channels of gauges, respectively, which were used for load balance. Strain surveys were run and the applied loads changed until the stress in the spars reached the proper level. Spectrum loading was then applied.

The YF-16 fuselage frame specimen was gauged with 20 channels of strain gauges shown in Figure E-8. Load was applied and strain data recorded until the proper stress level in the bulkhead was attained. The vertical tail test spectrum loads were then applied.

3.2 Inspections

The primary method of inspection was visual using a 4x and 8x magnifying glass. Other inspection techniques used were ultrasonic NDI and dye penetrant.

The titanium test specimens were inspected visually only during testing. After testing was completed the specimens were fluorescent penetrant inspected.

The aluminum I-beams and rear spars were inspected using the three techniques mentioned above.

The inspection schedule shown in Table E-VI was followed for visual inspections. The ultrasonic inspection schedule was used as a guideline with the actual inspection intervals based on test engineering judgement.

A metallurgical analysis was conducted on the first eight aluminum and two titanium I-beam specimens to determine the time of crack initiation in terms of spectrum block loading. Results of these analyses are described in Appendix F.

4.0 I-BEAM FATIGUE TESTS

The I-beam test phase of the program was considered developmental and therefore had procedural aspects that were peculiar to these specimens and not to the more straight-forward procedures followed for the rear spars and fuselage frame tests.

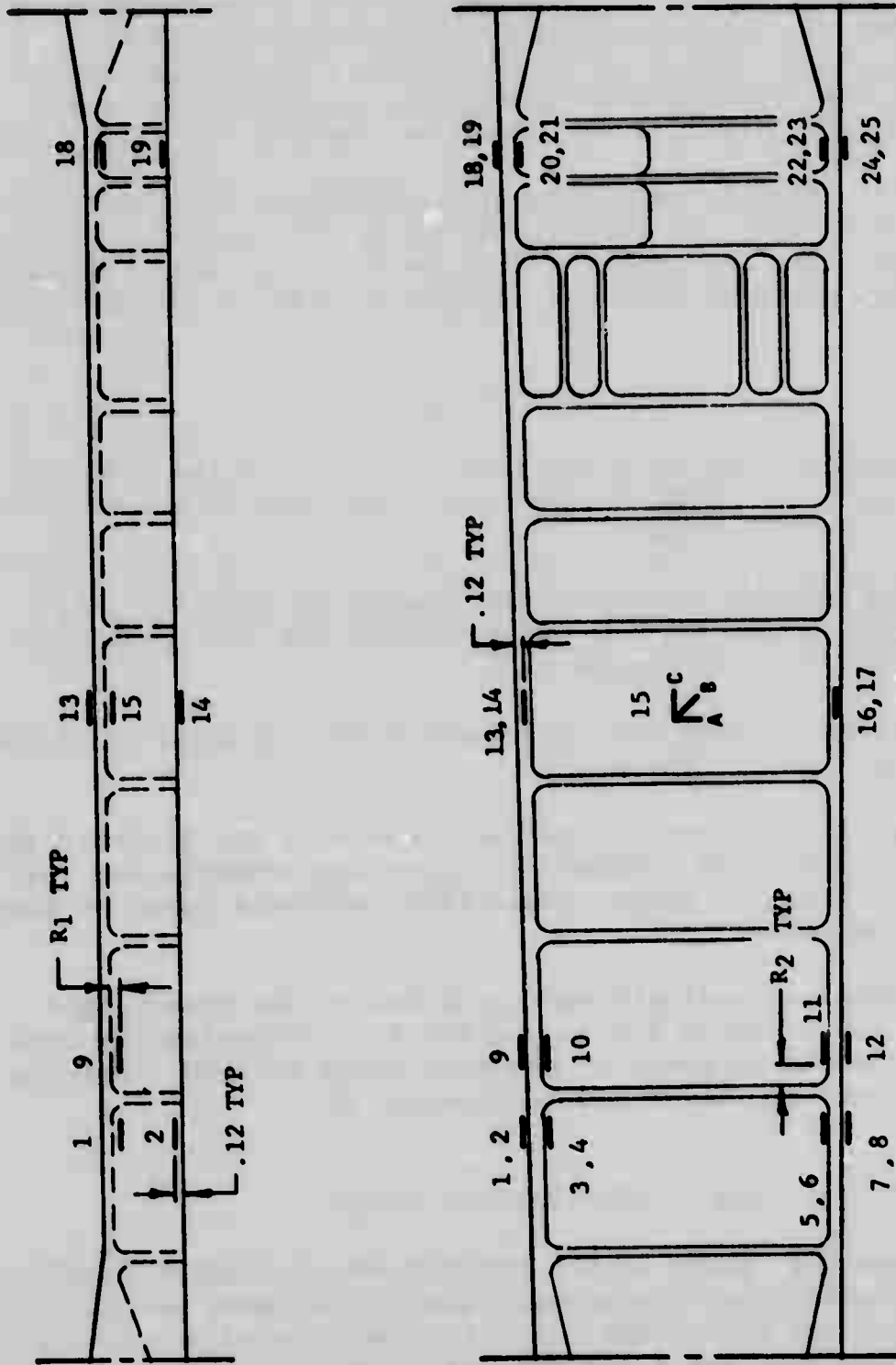

NOTES:
 1. ALL GAGES ON ONE BEAM ONLY. GAGES
 13 THRU 17 ON BALANCE OF BEAMS.

FIGURE E-6 F-111 INBOARD REAR SPAR SEGMENT -
 STRAIN GAUGE LOCATIONS (622-012)

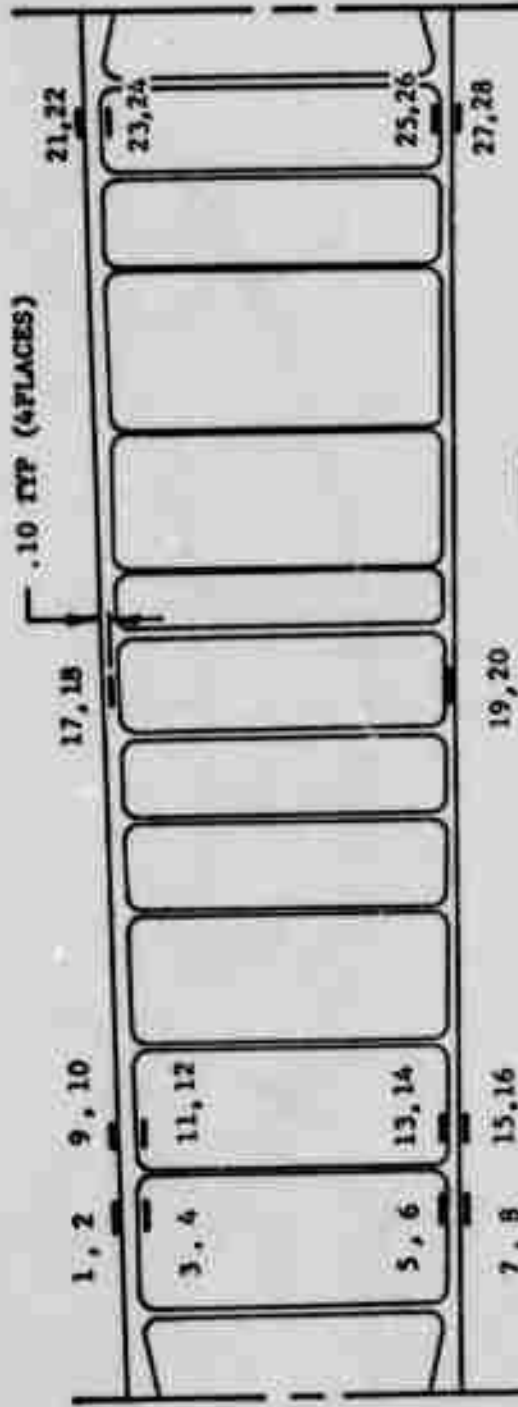
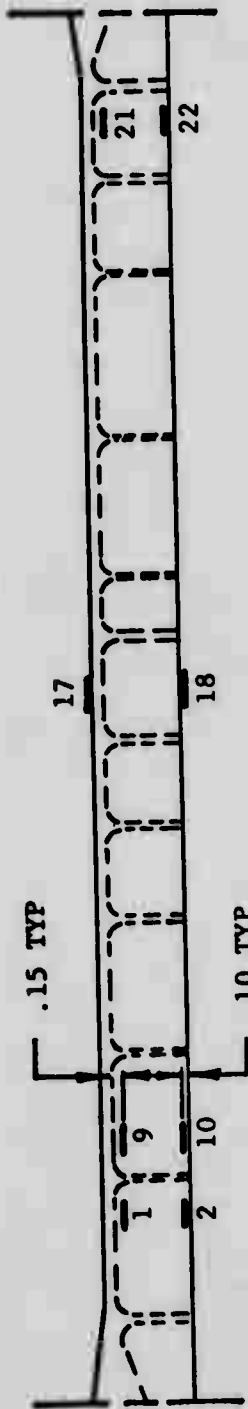

NOTES:
 1. ALL GAGES ON ONE BEAM ONLY.
 ONLY GAGES 17 THRU 20 ON
 BALANCE OF BEAMS.

FIGURE E-7 F-111 OUTBOARD REAR SPAR SEGMENT
 STRAIN GAUGE LOCATIONS (622-014)

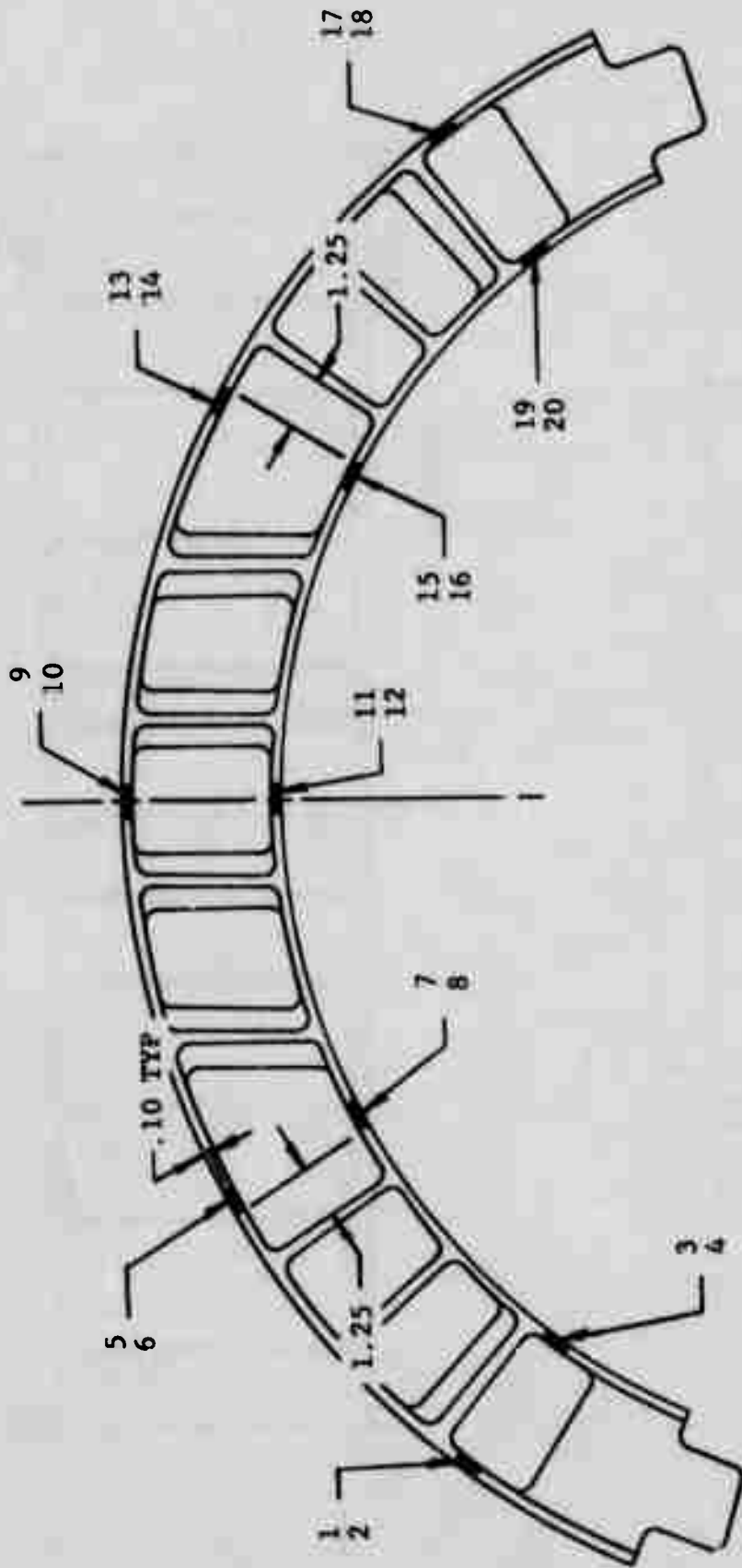

YF-16 FUSELAGE FRAME STRAIN GAUGE
LOCATIONS (622-013)

FIGURE E-8

TABLE E-VI
TEST INSPECTION SCHEDULE

Life	Blocks	I Beams			Rear Spar		YF-16 Frame 622-005 Type Inspection
		622-001 (Alum.) Type Inspection	622-002 (Ti.) Type Inspection	622-003 (Inbd.) Type Inspection	622-011 (Outbd.) Type Inspection		
1st 0 1/4 2/4 3/4	0	V	V	V	V	V	V
	5	V	V				
	10						
	15						
2nd 0 1/4 2/4 3/4	20	V	V	V	V	V	V
	25						
	30						
	35						
3rd 0 1/4 2/4 3/4	40	V, U*	V, U*	V, U*	V, U*	V, U	V, U
	45	V	V	V	V	V	V
	50						
	55						
4th 0 1/4 2/4 3/4	60	V, U*	V, U*	V	V	V	V
	65	V	V	V	V	V	V
	70	V	V	V	V	V	V
	75	V	V	V	V	V	V
5th 0 1/4 2/4 3/4	80	V, U	V, U	V, U*	V, U*	V, U*	V, U*
	85	V	V	V	V	V	V
	90	V, U	V, U	V	V	V	V
	95	V	V	V	V	V	V
6th 0 1/4 2/4 3/4	100	V, U	V, U	V, U	V, U	V, U	V, U
	105	V	V	V	V	V	V
	110	V, U	V, U	V	V	V	V
	115	V	V	V	V	V	V
7th 0	120	V, U (Same as 6th)	V, U (Same as 6th)	V, U End	V, U End	V, U End	V, U End

V - Visual inspection U - Ultrasonic inspection * \pm 1/2 life, not to exceed 1 1/2 life between inspections except where indicated

4.1 Test Procedure Variations

All the I-beam specimens were tested until catastrophic failure occurred. During the course of testing, the stress level in the aluminum beams was increased above the F-111 spectrum maximum stress of 24,000 psi and the YF-16 spectrum maximum stress of 30,000 psi. This occurred after demonstrating their respective service life requirements without developing any cracks. The cracks that developed as a result of the increased loading did not represent the aircraft structural experience. The purpose of these tests was to generate cracks to illustrate the surface integrity relationship between as-machined and hand-finished surfaces.

Doublers were added to each flange at both ends of the beams as shown in Figure E-9. These were required to provide reinforcement to the I-beams in the load transition sections so as to generate more cracks elsewhere in the beam span. Later, the resultant excessive beam life dictated the removal of the doublers. See Appendix F for details.

Four of the aluminum I-beams, without doublers, had 1/4" diameter holes drilled in each flange using a drill template. A total of 72 holes per beam was drilled in the flanges as shown in Figure E-10. Holes were drilled and deburred using standard aircraft techniques. Holes were of typical aircraft quality. These were all tested to the YF-16 spectrum at a maximum stress level of 30,000 psi.

The six titanium I-beams, without doublers were tested to the YF-16 load spectrum. Four were tested to a maximum spectrum stress of 94,000 psi, one to 87,000 psi and one to 68,000 psi stress since these appeared to have typical, progressive fatigue crack development.

4.2 I-Beam Orientation

In order to identify the location of a crack or failure on an I-beam the orientation scheme shown in Figure E-11 was established. The mark on the end of the hand-finished portion of the beams was used to orient the beam for identifying the upper and lower flange and the near and far side of the beam. Each bay in the beam was numbered at the flange-stiffener intersection for more precise crack or failure location along the beam length.

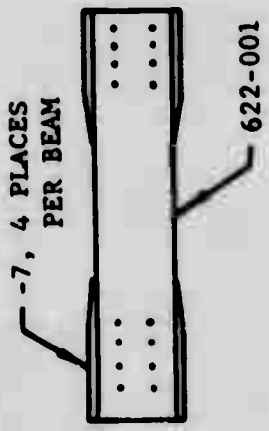
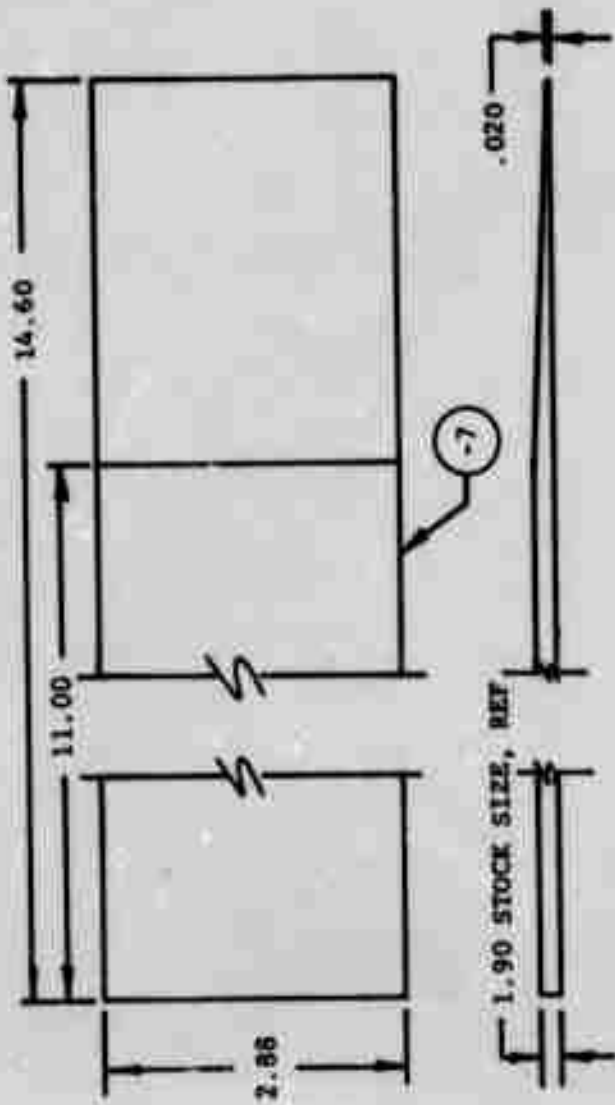

Ⓐ CHG - CHG'D ADHESIVE - REVISED
 NOTES 1 & 2, DELETED NOTE 3
 CED 4/2/75

4. DEBURR SHARP EDGES .015R OR 45° x .015.

Ⓐ 3.

Ⓐ 2. BOND DOUBLERS TO BEAMS USING FMS-1097. USE
 CLAMPS TO MAINTAIN ADEQUATE PRESSURE DURING
 CURE. CURE 2 HRS AT 270°F AND COOL SLOWLY
 TO R.T. UNDER CLAMP PRESSURE.

Ⓐ 1. CLEAN DOUBLERS & BEAMS PER FPS 1009.
 NOTES:

MAT'L: .190 x 3 x 15, 2024-T62
 PER QQ-A-250/4

FIGURE E-9 DOUBLER - ALUMINUM I-BEAM (622-015)

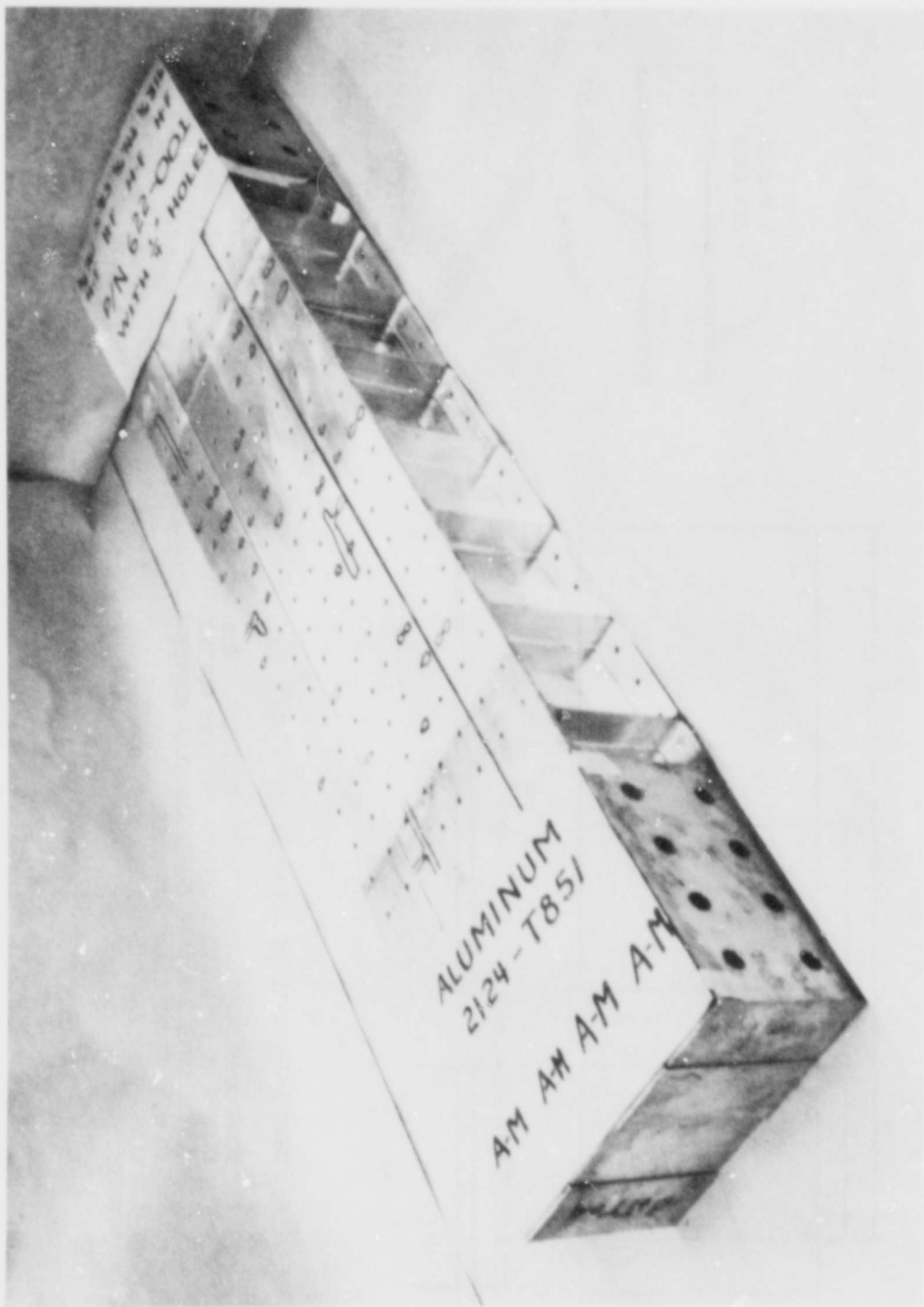

FIGURE E-10 1/4 INCH DIAMETER HOLES - ALUMINUM I-BEAMS

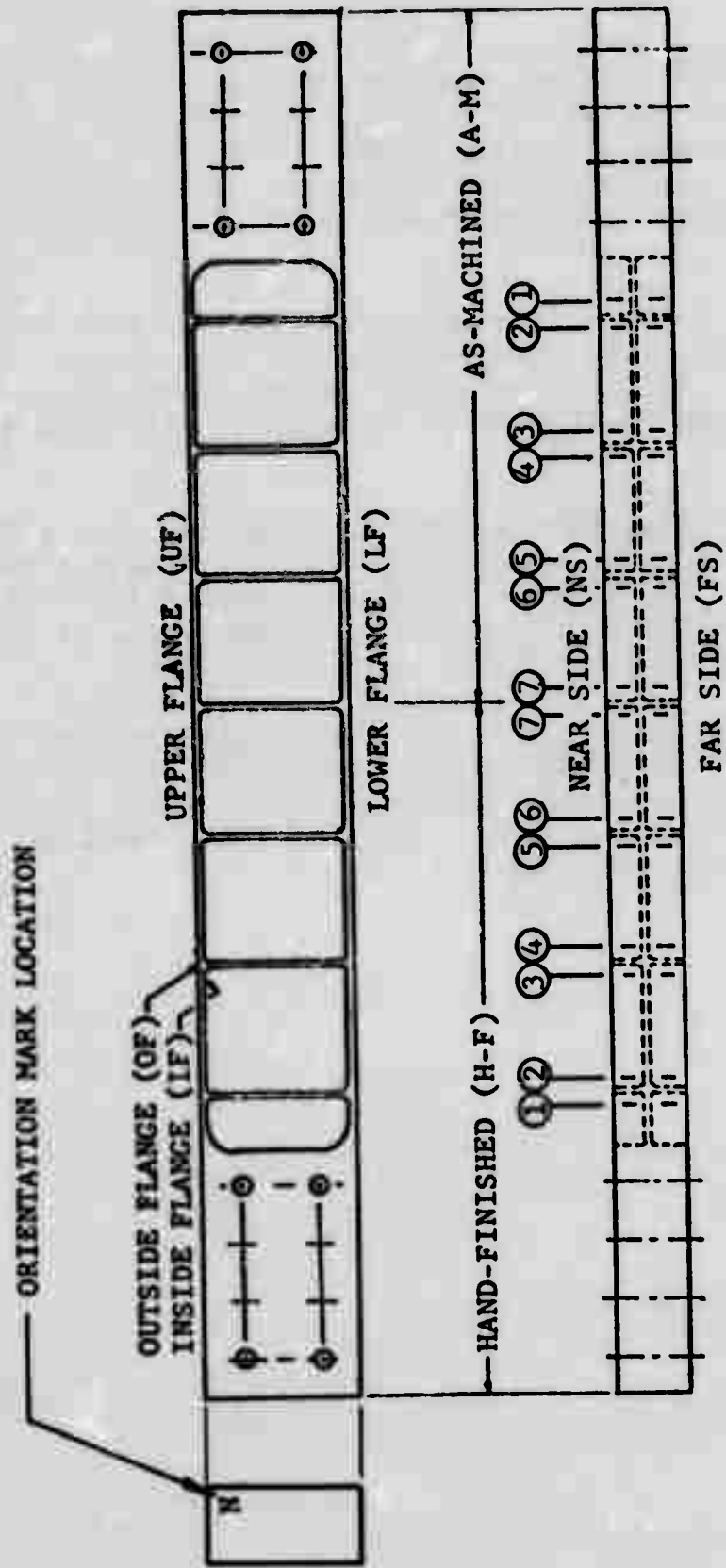

FIGURE E-11 I-BEAM ORIENTATION

5.0 FATIGUE TEST SPECTRA

The F-111 test spectrum was used to test aluminum specimens only. The YF-16 test spectrum was used to test aluminum and titanium specimens. The YF-16 vertical tail test spectrum was used to test the titanium fuselage frame. Each test spectrum represents current aircraft design usage and was applied in randomized block form. Appendix D tabulates all three fatigue test spectra.

The 124-layer F-111 test spectrum was applied as a 200 flight-hour block. Repeating the spectrum 20 times represented one 4000-hour service life. The maximum (100%) stress level of 24 ksi is representative of the F-111 aluminum wing stress level as maximum spectrum load.

The 120-layer YF-16 test spectrum was applied as a 400-flight-hour block. Repeating the spectrum 20 times represented one 8000-hour service life. The maximum (100%) stresses of 30.7 ksi (aluminum) and 61.4 ksi (titanium) are representative of YF-16 wing stresses at maximum spectrum load.

The 11 layer YF-16 vertical tail root rolling movement test spectrum was applied as a 400-flight-hour block. Repeating this block 20 times represents one 8000 hour service life. The maximum (100%) stress of 38 psi was representative of the fuselage frame stress at maximum spectrum load.

A P P E N D I X F
FATIGUE TEST HISTORY AND RESULTS

APPENDIX F
TABLE OF CONTENTS

	<u>Page</u>
1.0 SPECTRUM TEST DATA	170
1.1 I-Beam Spectrum Test Data	171
1.2 F-111 Rear Spar Segments Data	171
1.3 YF-16 Fuselage Frame Data	171
2.0 METALLURGICAL ANALYSIS	172

APPENDIX F

LIST OF ILLUSTRATIONS

<u>Figure</u>		<u>Page</u>
F-1	Fatigue Test History - I-Beam Specimens	175
F-2	Aluminum I-Beam Failure, S/N F409755	177
F-3	Aluminum I-Beam Failure, S/N F409764	178
F-4	Aluminum I-Beam Failure, S/N F409759	179
F-5	Aluminum I-Beam Failure, S/N F409758	180
F-6	Aluminum I-Beam Failure, S/N F409762	181
F-7	Aluminum I-Beam Failure, S/N F409757	182
F-8	Aluminum I-Beam Failure, S/N F409765	183
F-9	Aluminum I-Beam Failure, S/N F409760	184
F-10	Titanium I-Beam Failure, S/N F409768	185
F-11	Titanium I-Beam Failure, S/N F409767	186
F-12	Titanium I-Beam Failure, S/N F409771	187
F-13	Titanium I-Beam Failure, S/N F409772	188
F-14	Titanium I-Beam Failure, S/N F409769	189
F-15	Titanium I-Beam Failure, S/N F409770	190
F-16	Aluminum I-Beam Failure, with Fastener Holes, S/N F409761	191
F-17	Aluminum I-Beam Failure, with Fastener Holes, S/N F409763	192
F-18	Aluminum I-Beam Failure, with Fastener Holes, S/N F409766	193

APPENDIX F

LIST OF ILLUSTRATIONS (Cont'd)

<u>Figure</u>		<u>Page</u>
F-19	Aluminum I-Beam Failure, with Fastener Holes, S/N F411316	194
F-20	I-Beam Failure Location System	195
F-21	YF-16 Frame Failure	196
F-22	YF-16 Frame Failure - Close Up	197
F-23	YF-16 Frame Penetrant Inspection Crack Disclosure	198

APPENDIX F

LIST OF TABLES

<u>Table</u>		<u>Page</u>
F-I	Test Data Summary - Aluminum I-Beam Specimens	199
F-II	Test Data Summary - Titanium I-Beam Specimens	200
F-III	Test Data Summary - Aluminum I-Beam Specimens with $\frac{1}{2}$ " Fastener Holes	201
F-IV	Aluminum I-Beams - Crack Location and Roughness	202
F-V	Titanium I-Beams - Crack Location and Roughness	203
F-VI	Aluminum I-Beams with Fastener Holes - Crack Location and Roughness	204

APPENDIX F

FATIGUE TEST HISTORY AND RESULTS

The results of the spectrum fatigue testing of the I-beams are presented in tabulated format as visual and ultrasonic inspections that were made during testing. Also included are the metallurgical analyses of fractured surfaces from selected specimens of failed I-beams. Test results of the F-111 rear spar specimens and the F-16 frame assembly are also discussed.

Results of fatigue analyses are presented and explained in Appendix G.

1.0 SPECTRUM TEST DATA

Visual observations and ultrasonic inspections were made to detect cracks at intervals of spectrum loading. If a crack was observed before failure of the part, its location and number of blocks tested was recorded. If the crack size was not considered excessive, it was polished out and testing continued until another event occurred.

The I-beam tests were developmental tests to obtain quantitative data on the surface roughness effects on fatigue life. Doublers were added to the last five aluminum I-beams tested without fastener holes, to prevent a premature failure in the load transition area as experienced in the first three specimens. The doublers were deleted, however, from the titanium beams and the aluminum beams with fastener holes to obtain a shorter fatigue life, thus reducing the span time of testing.

The two F-111 rear spar tests and the YF-16 fuselage frame test were verification that the as-machined surface finished aircraft parts could adequately sustain their respective service lives at the prescribed maximum spectrum stress level.

1.1 I-Beam Test Data

A summary of the test data from the eighteen I-beams is presented in Tables F-I, F-II and F-III with a graphic description of the test history depicted in Figure F-1. Photographs of the failed specimens are presented as Figures F-2 through F-19 and are referenced according to specimen number in the data tabulation. Tables F-IV, F-V and F-VI summarize the cracks observed following testing, defining their locations and surface roughness of the beams at the site of crack initiation. Crack location nomenclature is presented in Figure F-20.

1.2 F-111 Rear Spar Segments Data

The four inboard rear spar members were tested in pairs for 120 blocks of the F-111 spectrum maximum stress of 24,000 psi with no cracks or failures. The four outboard rear spar members were also tested in pairs for 120 blocks of the F-111 spectrum, but at a maximum stress of 28,000 psi. No cracks or failures were experienced during this period. Testing was continued on the outboard spars until all other program testing was completed. One pair sustained 228 blocks, the other pair 230 blocks with no cracks detected by either visual observations or penetrant inspection.

1.3 YF-16 Fuselage Frame Data

The YF-16 fuselage frame assembly specimen was tested for 60 blocks of the YF-16 vertical tail rolling moment test spectrum (the assumed life requirement) with a maximum stress of 38,000 psi (the design maximum spectrum stress level). No cracks were revealed by visual inspection. The maximum spectrum stress was then increased to 67,000 psi and the test run until failure occurred in block 5, layer 4, cycle 1 of this higher stress loading.

The primary failure occurred in the hand-finished section of -7 and is shown in Figures F-21 and F-22. The fracture surface was damaged due to the reversed spectrum loading and could not be analyzed for the time of crack initiation. After the frame assembly was removed from the test fixture, visual examination revealed two additional cracks - one in the as-machined surface of -7 and one in the hand-finished surface of -9. Fluorescent penetrant inspection discovered eight more cracks - all in as-machined surfaces. Figure F-23 summarizes all cracks discovered.

2.0 METALLURGICAL ANALYSIS

A metallurgical examination and analysis was conducted on the eight aluminum I-beams without fastener holes and two of the six titanium I-beams to determine the effective crack origin time. The test blocks required to initiate the critical crack of these aluminum and titanium specimens are summarized in Tables F-I and F-II respectively. Note that four of the titanium beams had crack initiation simultaneous with failure. A discussion of the metallurgical observations for each of the I-beams analyzed is presented below.

Specimen S/N F409755

Two fatigue origins "a" and "b" were seen, see Figure F-2. The primary origin started at Blk 130 while origin "b" started at Blk 135.

Specimen S/N F409764

The subject specimen had failed during LL108 of block 115. The first 80 blocks were cycled with the 100% load equal to 24 ksi while the 100% load for the last 35 blocks plus 108 load levels was equal to 45 ksi. Figure F-3 is a view of the fatigue crack growth

The growth dimensions are as follows

	a	2c	a/2c
1. End of block 80 (100% = 24 ksi)	.015	.070	.21
2. During 100% = 45 ksi	.070	.35	.20
3. During 100% = 45 ksi	.11	.43	.26
4. Failure Blk 36 LL108 (100% = 45 ksi)	.2028	.985	.21
5. Aluminum total thickness	.2356		

A crack existed at the end of the first 80 blocks of 100% = 24 ksi as seen above. The a/2c reflects the effect of the multiple origins combining to form a single "2c" dimension at an "a" depth.

Specimen S/N F409759

There were two fatigue origins as seen in Figure F-4. The primary origin "a" started at Blk 202 and became a thru crack at Blk 259. Although the majority of the crack was ground out at the end of Blk 225, there still remained a portion of the original fatigue crack. The second fatigue origin "b" started at Blk 210. Origin "b" was present after the Blk 225 grind out.

Specimen S/N F409758

A single origin can be seen in Figure F-5. The crack became a thru crack during Blk 417. The effective fatigue starting time was approximately Blk 296.

Specimen S/N F409762

The fatigue crack was seen progressing through the stiffener, Figure F-6, with the fatigue origin lying at the specimen corner, Figure F-6a. The effective origin starting time was approximately Blk 229.

Specimen S/N F409757

The effective fatigue starting time was at approximately Blk 157. The fatigue origin resulted from a damaged (bruised) corner of the high stressed flange.

Specimen S/N F409765

A single origin is seen in Figure F-8a. The effective starting time occurred at approximately Blk 183 and became a thru crack at Blk 288. Figure F-8b represents the crack growth along the short transverse direction.

Specimen S/N F409760

One primary origin was visible, Figure F-9a. The fatigue origin resulted from fabrication damage when the doublers were added to this specimen. Figure F-9b, an oblique view of the specimen corner, showed the damaged surface near the corner-fracture-doubler area. The fatigue origin started at Blk 101 during the 35 ksi max. stress.

Specimen S/N F409772

The fatigue origin (arrow) lies approximately 0.4 inches from the edge on the inner surface of location #1, far side, of the hand-finished end as shown in Figure F-12. The effective crack starting time was approximately block 24 to 29.

Specimen S/N F409770

The fatigue origin shown in Figure F-14 lies just in from the far side edge of the lower flange on the outer surface in location #1, of the hand-finished end. The effective crack starting time was approximately block 62.

REF NO.	BEAM S/N	START DATE	TYPE MAT'L	TYPE SPECTRUM	1/4" D HOLES	0 20 40 60 80 100				
						F-16 F-111				
1	754	11-22-74	ALUM	F-111	NO	P	24 KSI	45 KSI		
2	764	11-25-74	ALUM	F-111	NO	P	24 KS	45 KSI		
3	759	12-05-74	ALUM	F-111	NO		24 KSI	45 KSI		
4	758	02-17-75	ALUM	F-111	NO	DA	30 KSI		U U U U U	
5	757	04-14-75	ALUM	F-16	NO	DA	30 KSI			U U U
6	762	02-21-75	ALUM	F-111	NO	DA	30 KSI			U U U
7	765	05-12-75	ALUM	F-16	NO	DA	35 KSI			
8	760	06-04-75	ALUM	F-16	NO	DA	35 KSI			
9	768	06-24-75	TI	F-16	NO	DA	90 KSI	DK 94 KSI		71 HF#1
10	767	07-08-75	TI	F-16	NO		84 KSI	28 AM#1		
11	771	07-08-75	TI	F-16	NO		74 KSI	32 AM#1		
12	772	07-14-75	TI	F-16	NO		87 KSI			62 HF#1
13	769	07-16-75	TI	F-16	NO		94 KSI	35 AM#3-4		
14	770	07-23-75	TI	F-16	NO		62 KSI			
15	761	07-29-75	ALUM	F-16	YES		30 KSI		55 HF#7	
16	763	07-29-75	ALUM	F-16	YES		30 KSI		65 AM#2	
17	766	07-30-75	ALUM	F-16	YES		30 KSI		62 HF#6-7	
18	316	08-07-75	ALUM	F-16	YES		30 KSI		48 HF#6	

B L O C K S

100 120 140 160 180 200 220 240 260 280 300 320

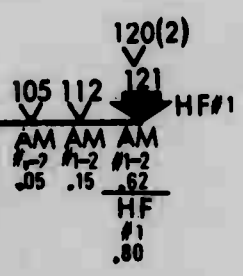
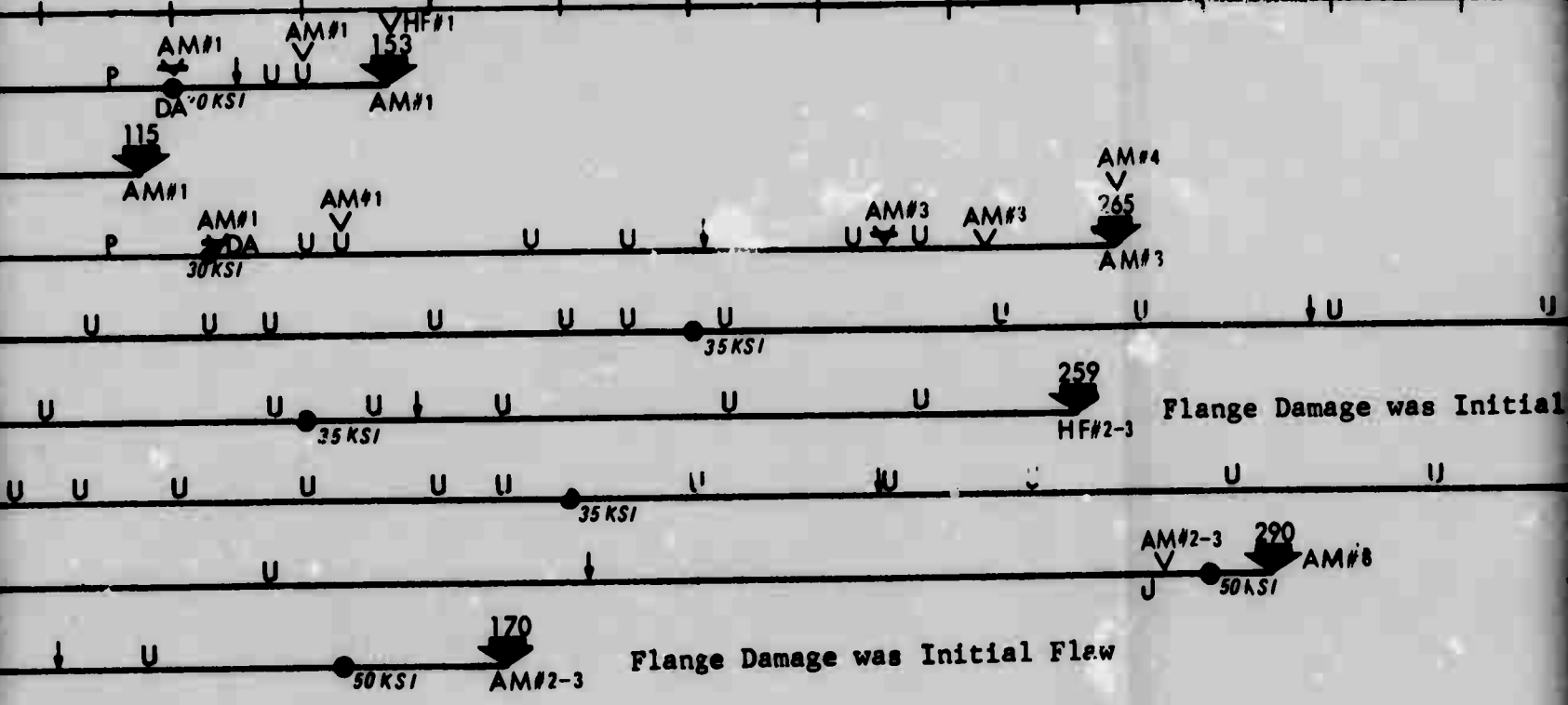

AM	- AS-MACHINED END OF BEAM
HF	- HAND-FINISHED END OF BEAM
#X	- BEAM LOCATION NUMBER X
DA	- DOUBLER ADDED
U	- ULTRASONIC INSPECTION
P	- PENETRANT INSPECTION
∇	- CRACK DISCOVERED
∇	- CRACK DISCOVERED AND REPAIRED

260 280 300 320 340 360 380 400 420

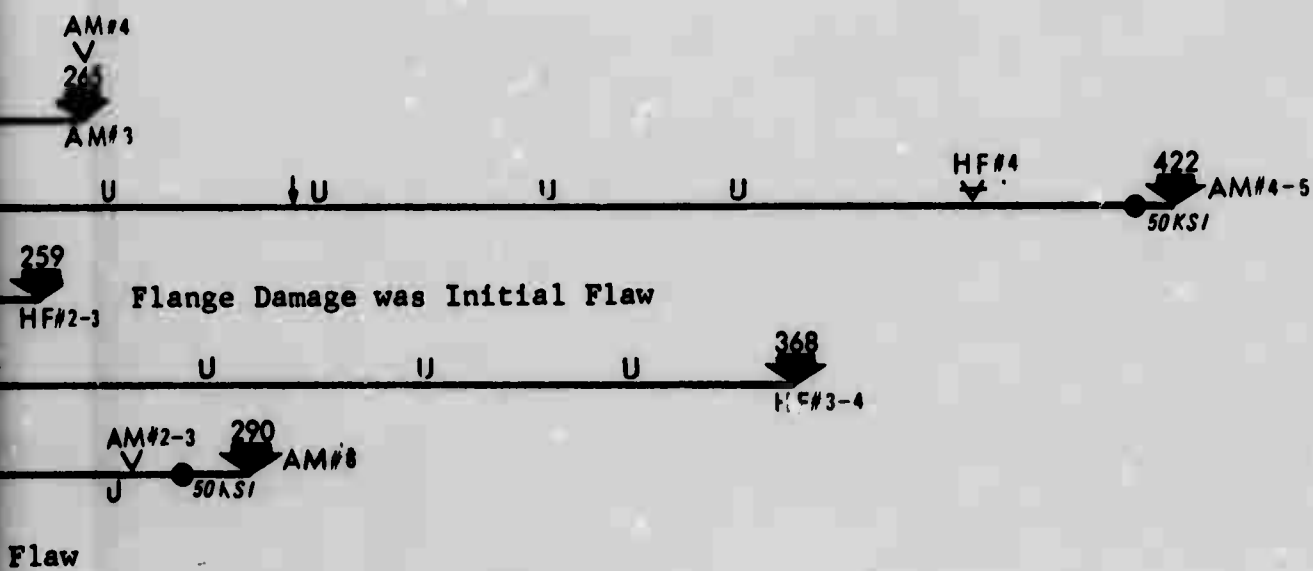

L E G E N D

AM - AS-MACHINED END OF BEAM	↓ - CRITICAL CRACK INITIATION
HF - HAND-FINISHED END OF BEAM	⋈ - X CRACKS EMANATING FROM HOLES
#X - BEAM LOCATION NUMBER X	● - LOAD CHANGE
DA - DOUBLER ADDED	XX ksi - NOMINAL STRESS IN CRITICAL SECTION OF BEAM
U - ULTRASONIC INSPECTION	.XX - MEASURED CRACK LENGTH
P - PENETRANT INSPECTION	XXX - BEAM FAILURE AT XXX BLOCKS
∨ - CRACK DISCOVERED	DR - DOUBLER REMOVED
↘ - CRACK DISCOVERED AND REMOVED	

FIGURE F-1 FATIGUE TEST HISTORY
175 - I-BEAM SPECIMENS

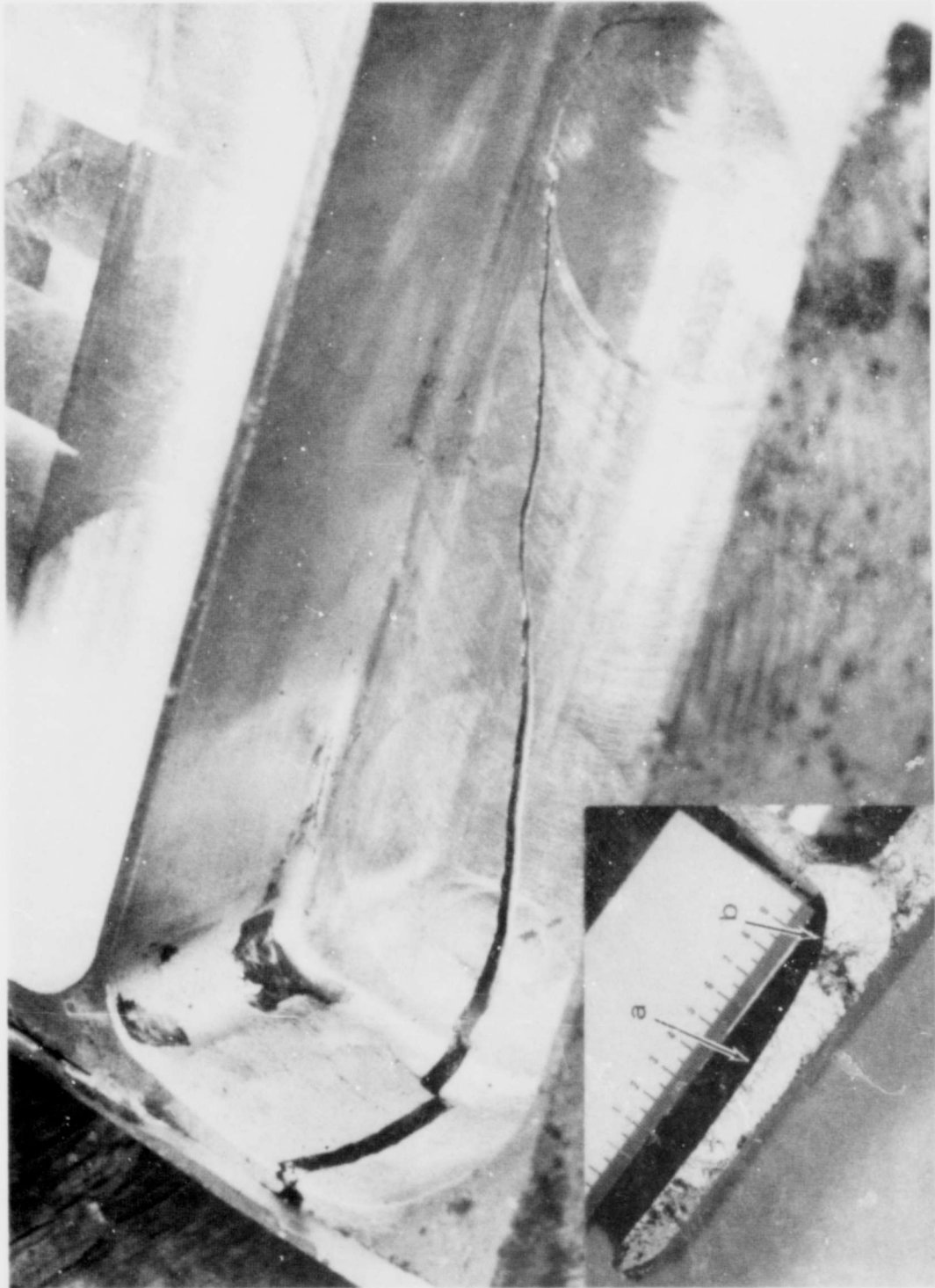

FIGURE F-2 ALUMINUM I-BEAM FAILURE, S/N F409755

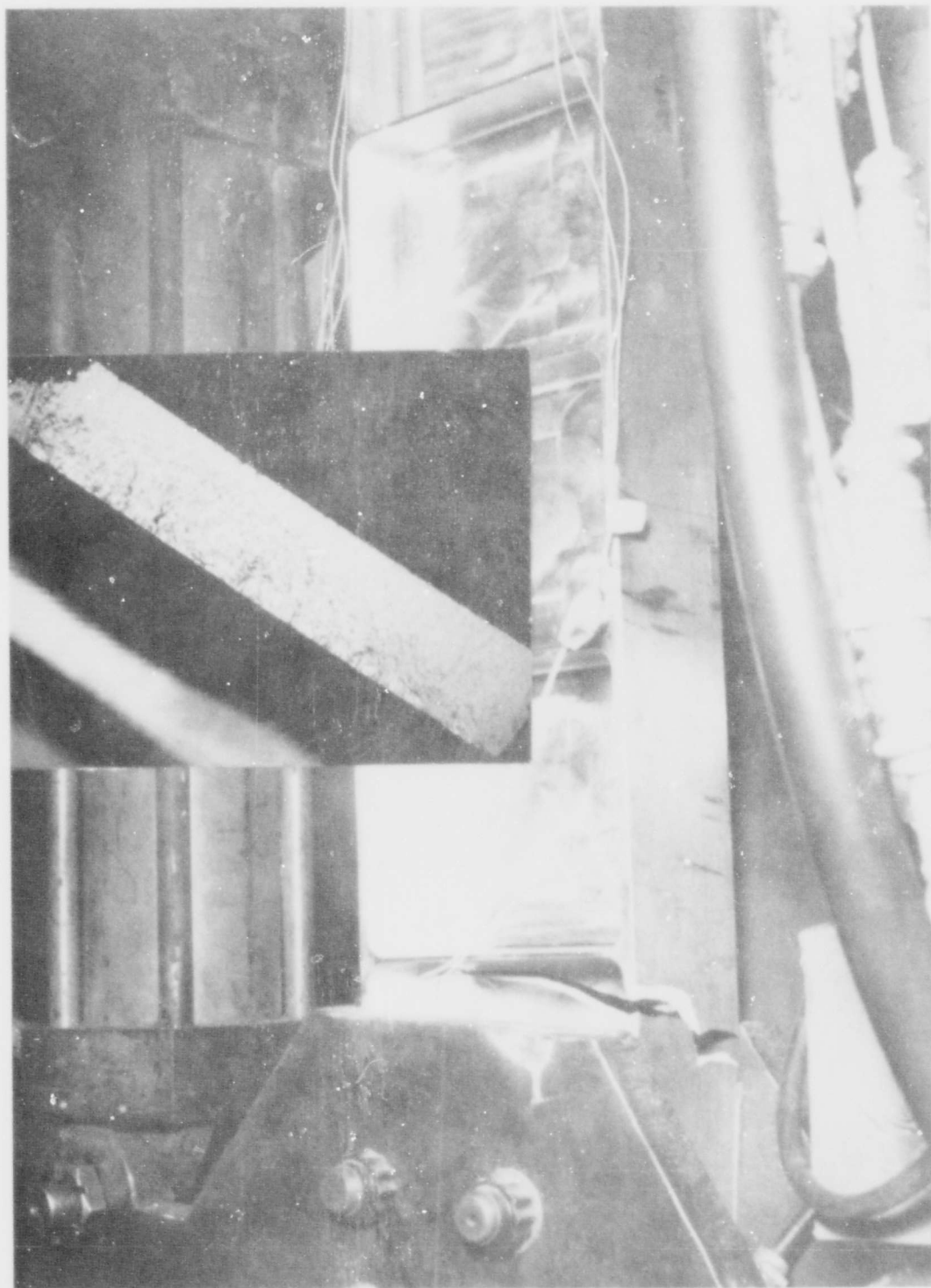

FIGURE F-3 ALUMINUM I-BEAM FAILURE, S/N F409764



FIGURE F-4 ALUMINUM I-BEAM FAILURE, S/N F409759

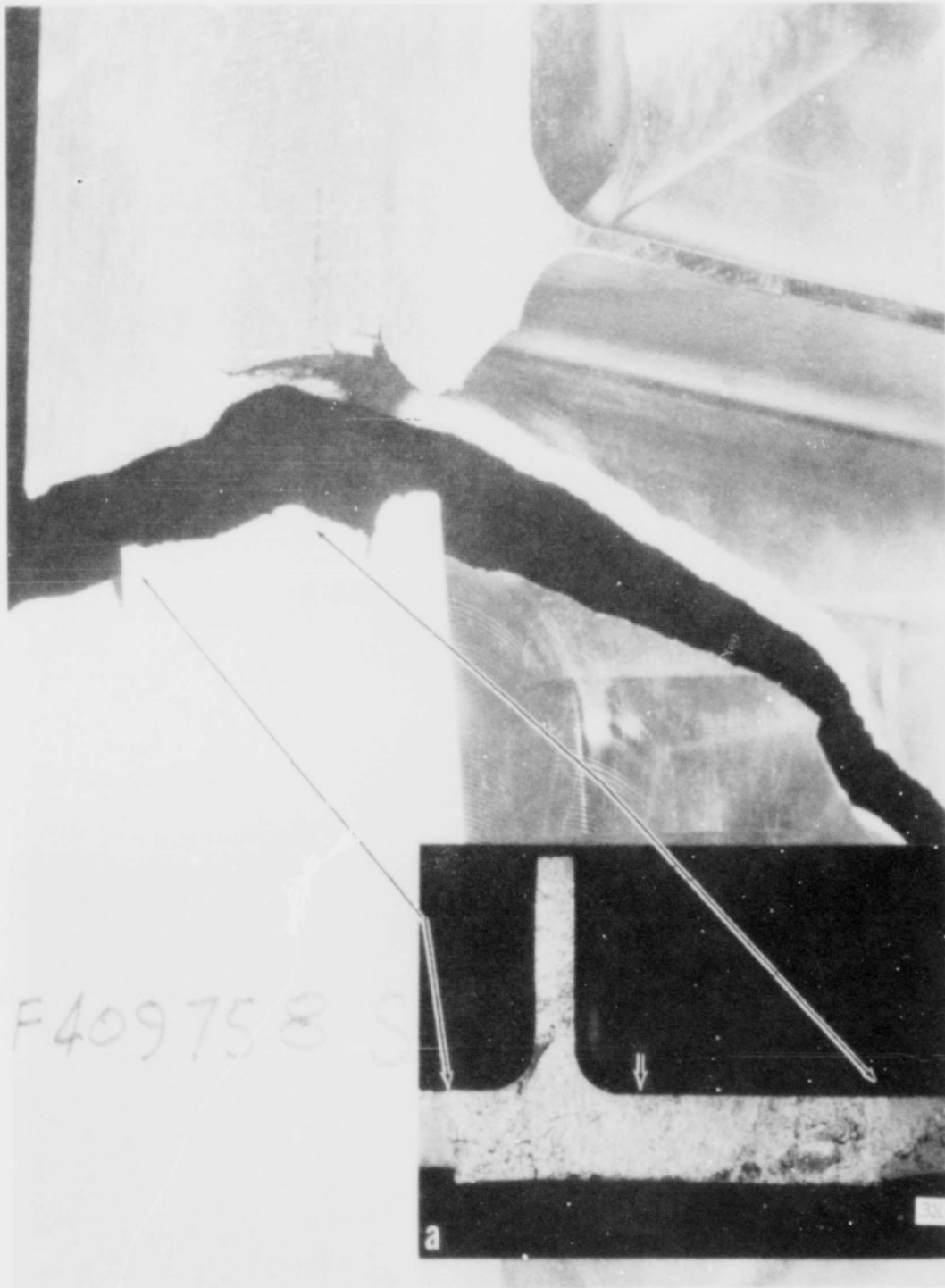

FIGURE F-5

ALUMINUM I-BEAM FAILURE, S/N F409758



FIGURE F-6 ALUMINUM I-BEAM FAILURE, S/N F409762

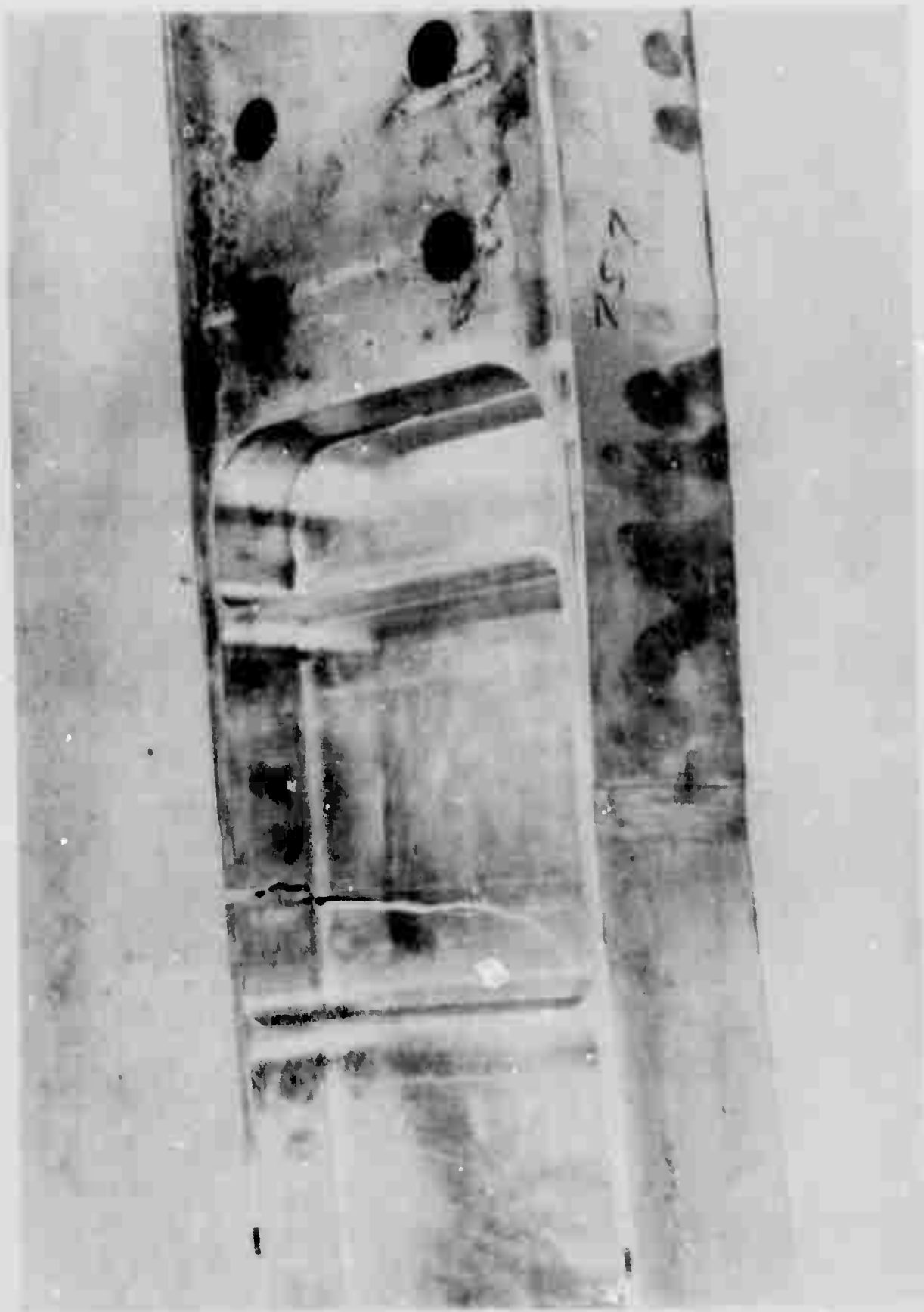

FIGURE F-7 ALUMINUM I-BEAM FAILURE, S/N F409757

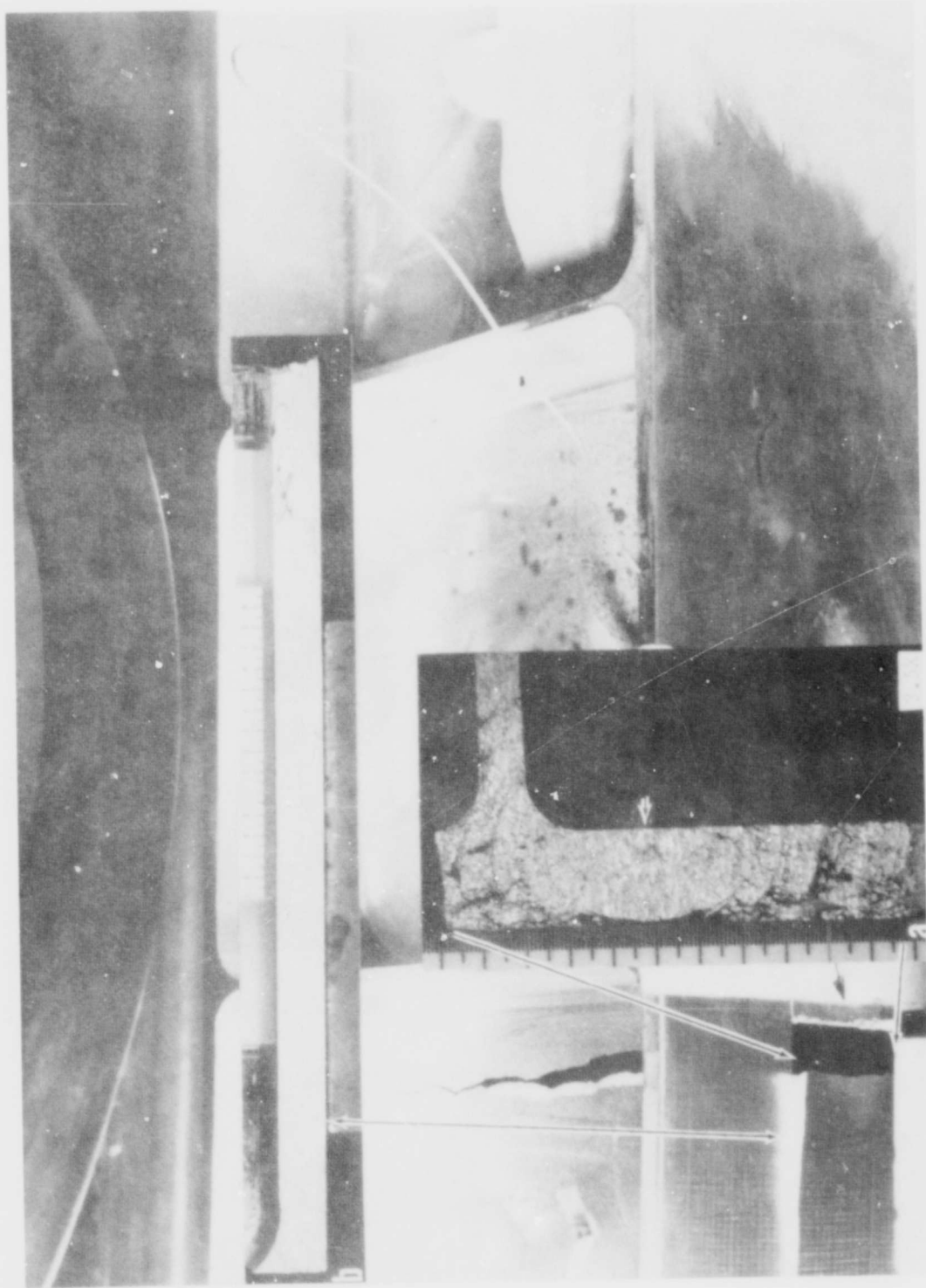

FIGURE F-8 ALUMINUM I-BEAM FAILURE, S/N F409765

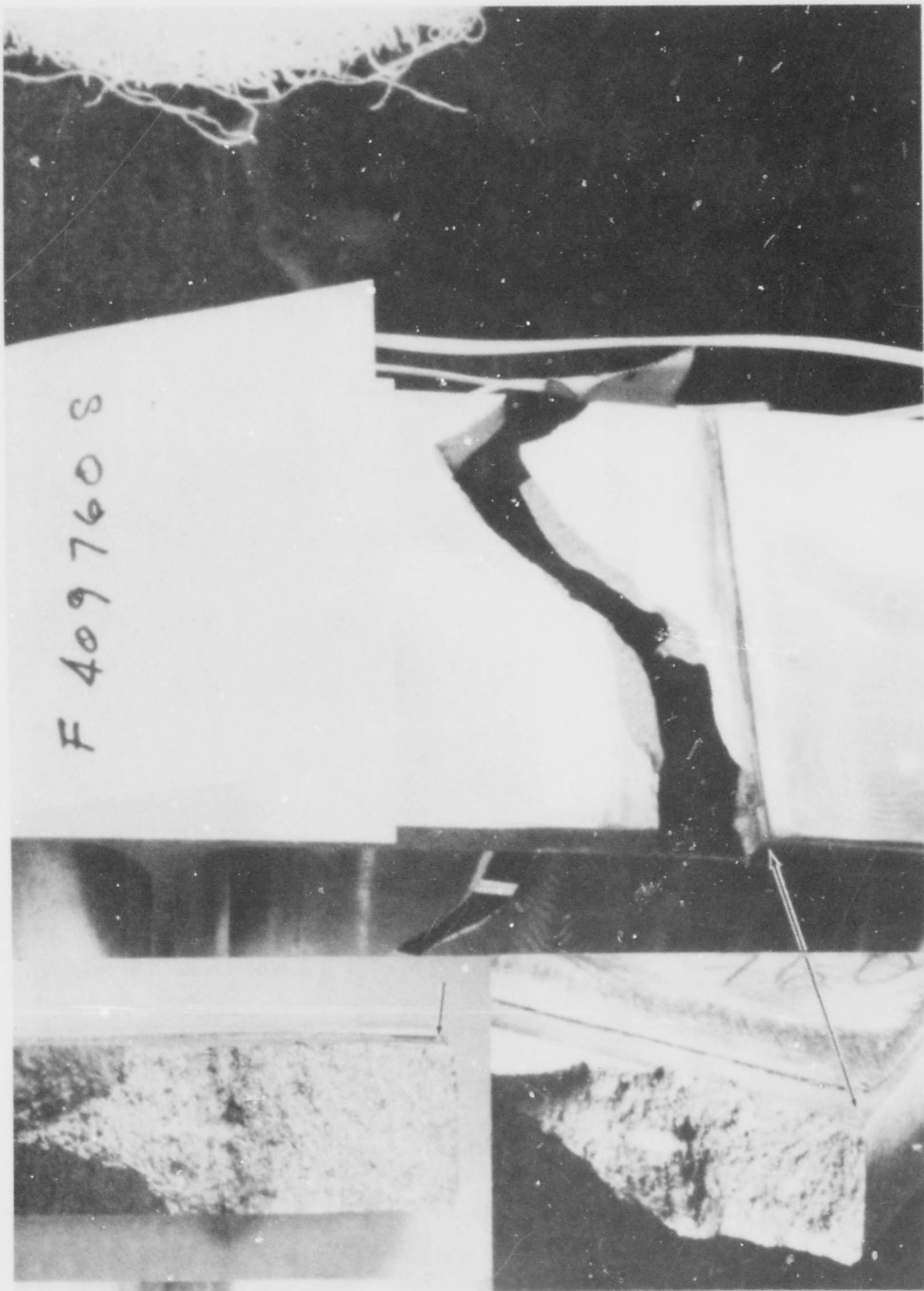

FIGURE F-9 ALUMINUM I-BEAM FAILURE, S/N F409760

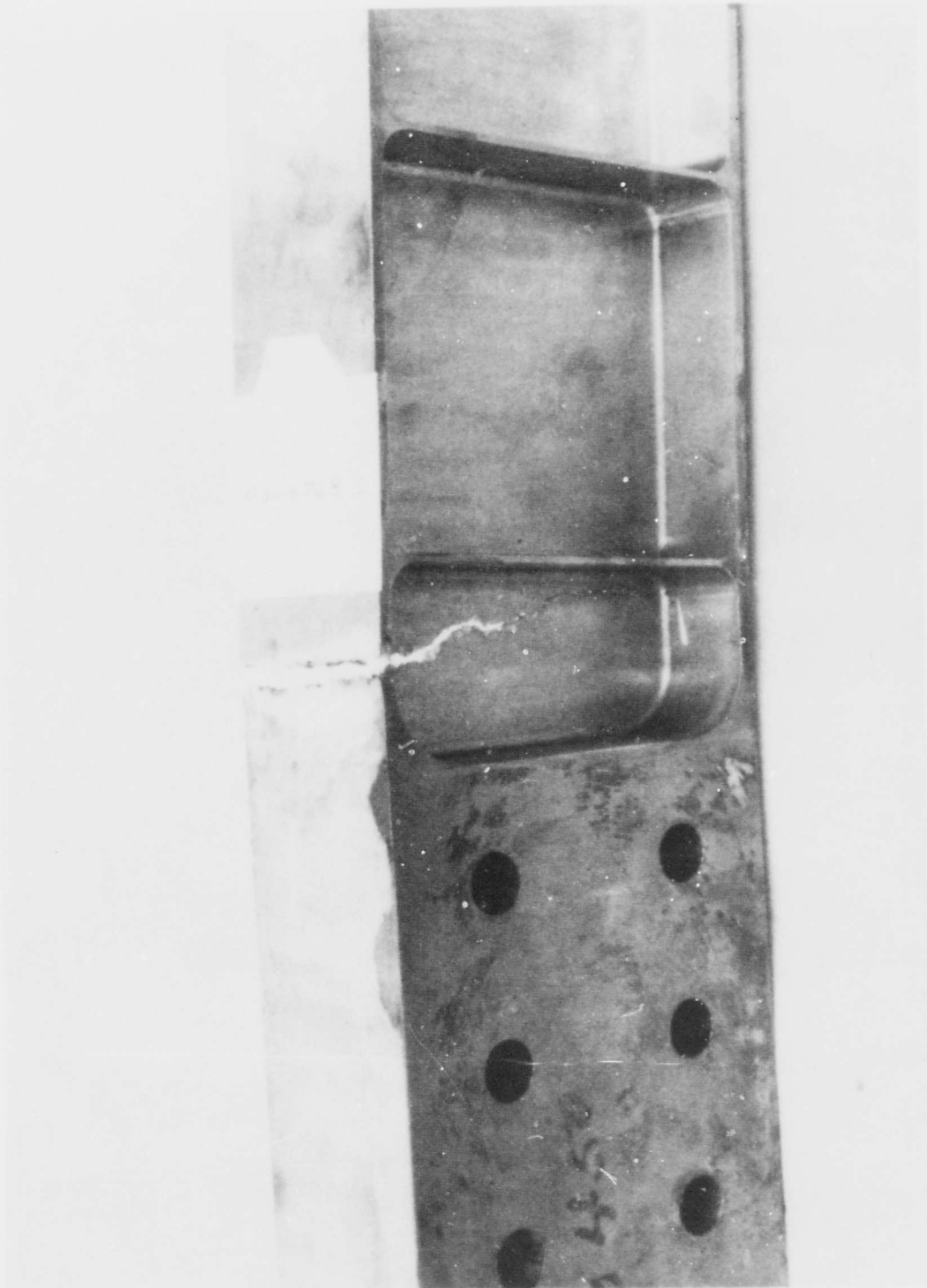

FIGURE F-10 TITANIUM I-BEAM FAILURE, S/N F409768

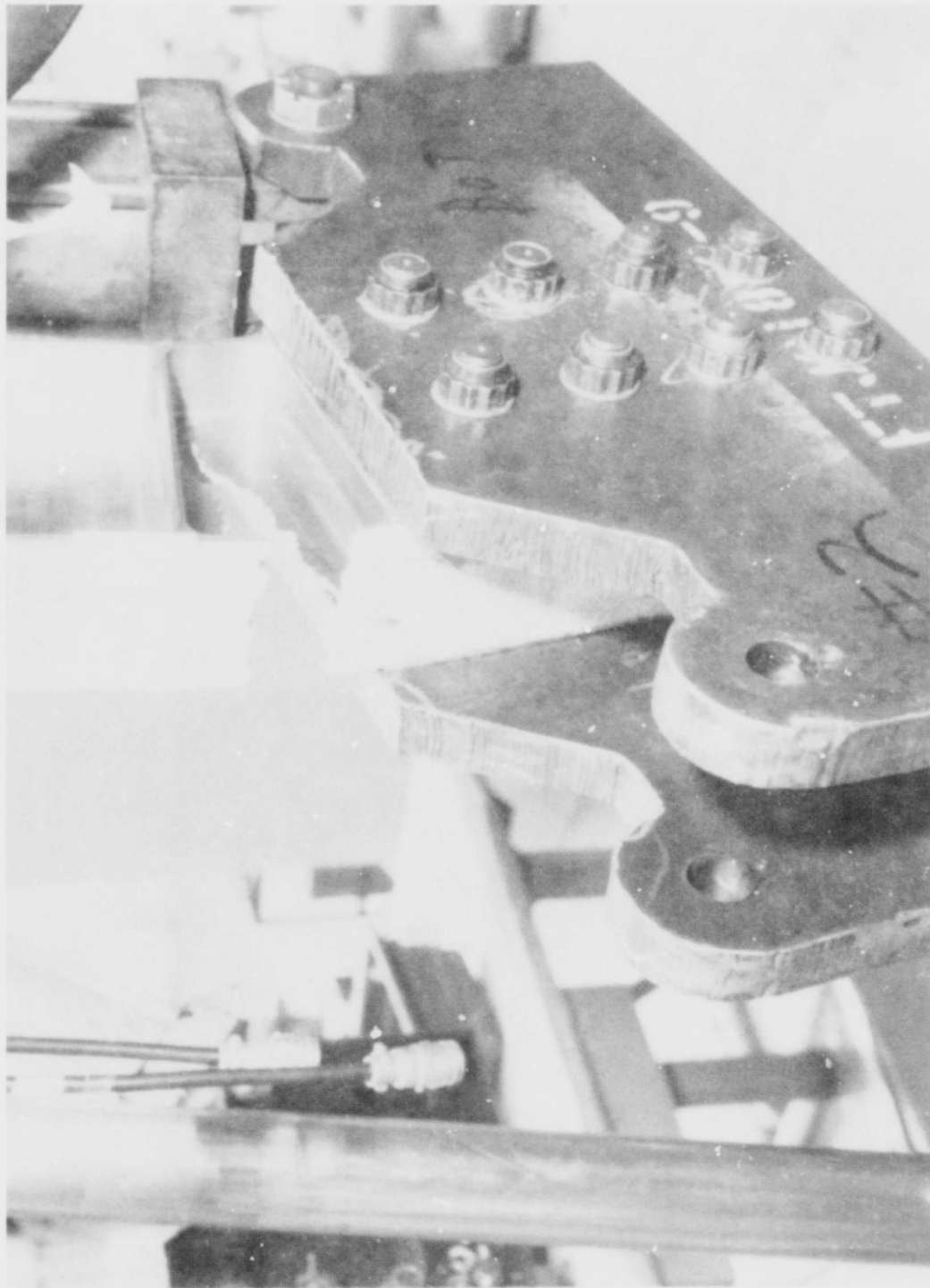

FIGURE F-11 TITANIUM I-BEAM FAILURE, S/N F409767

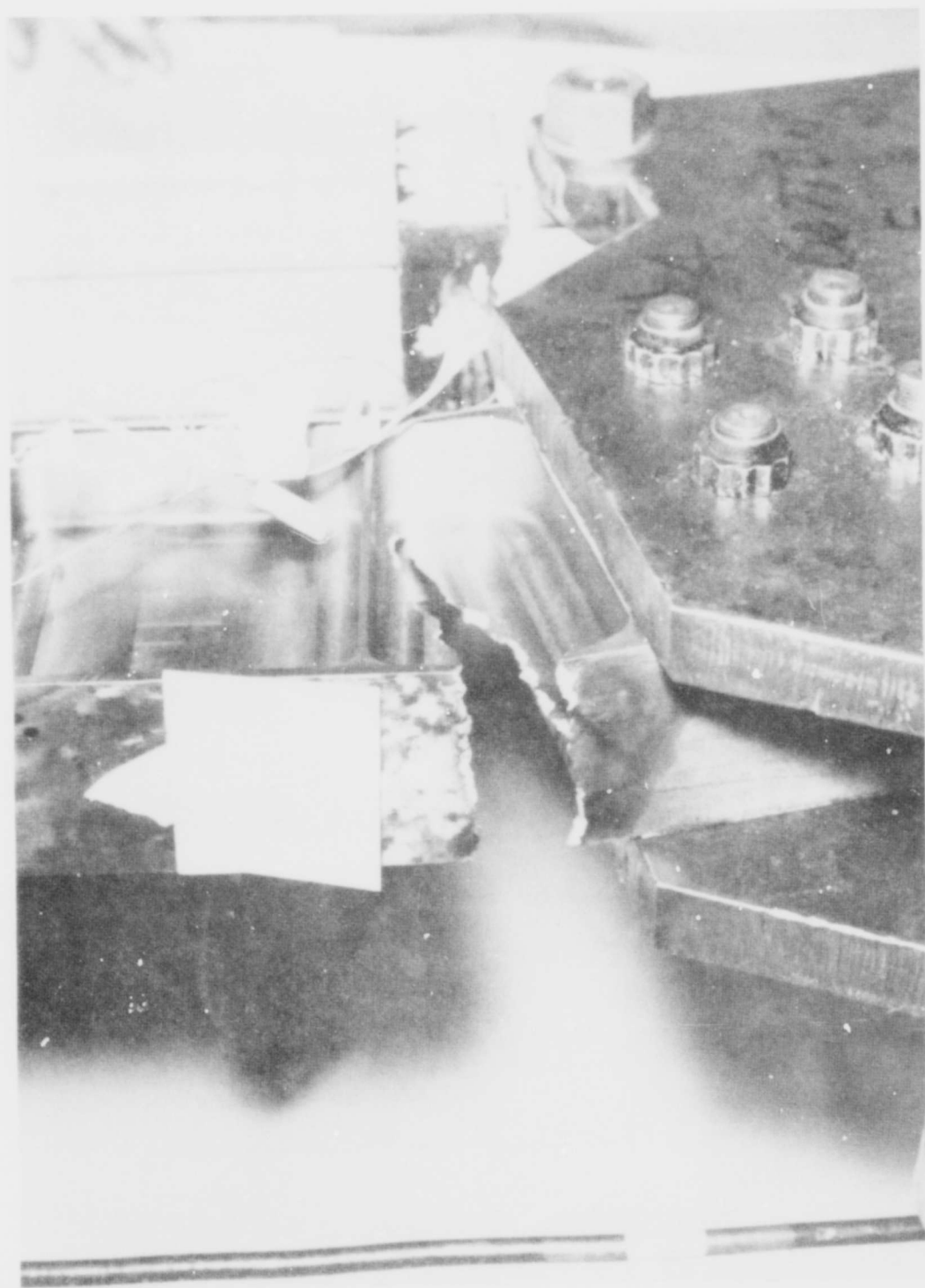

FIGURE F-12 TITANIUM I-BEAM FAILURE, S/N F409771

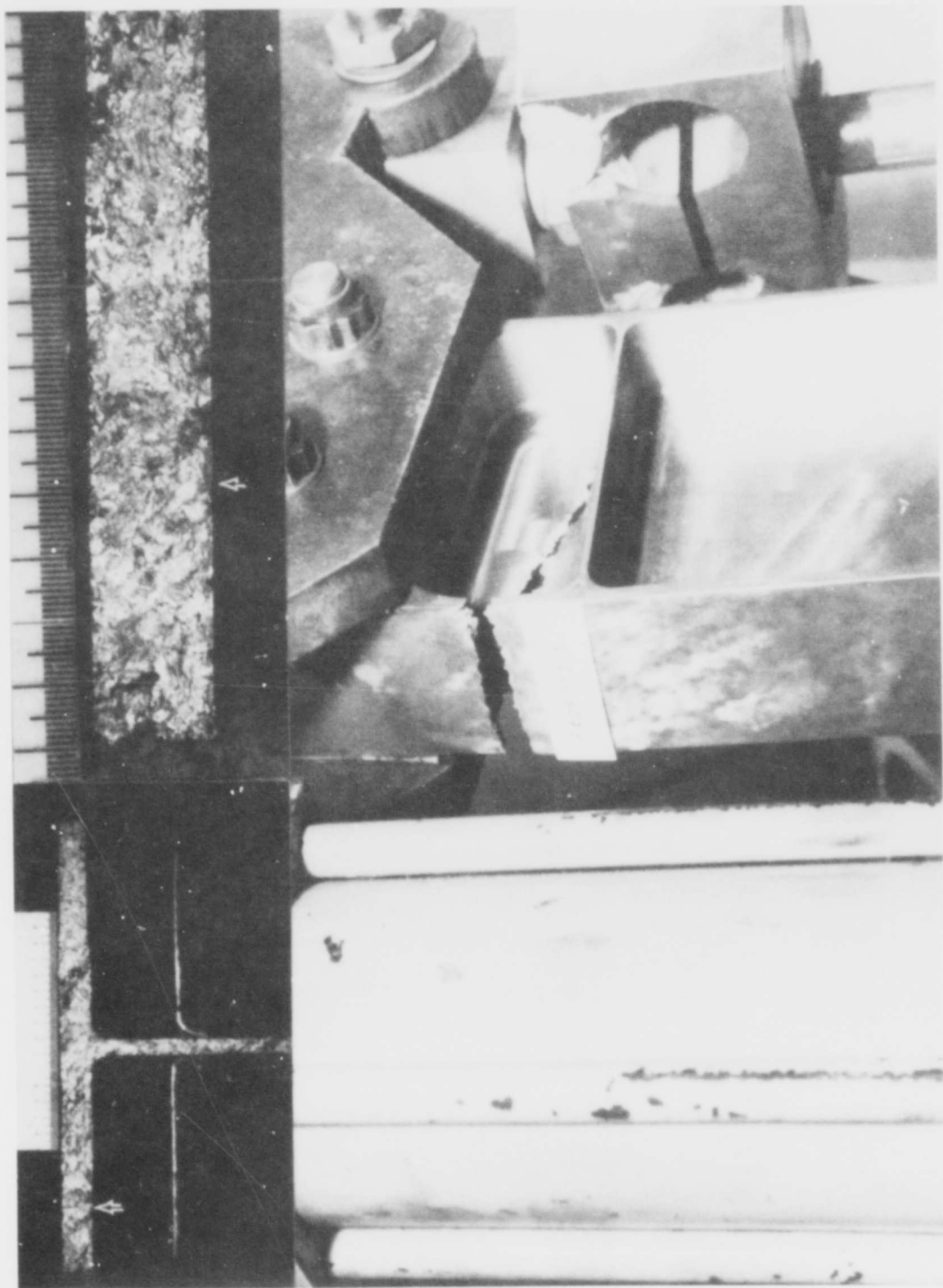

FIGURE F-13 TITANIUM I-BEAM FAILURE, S/N F409772

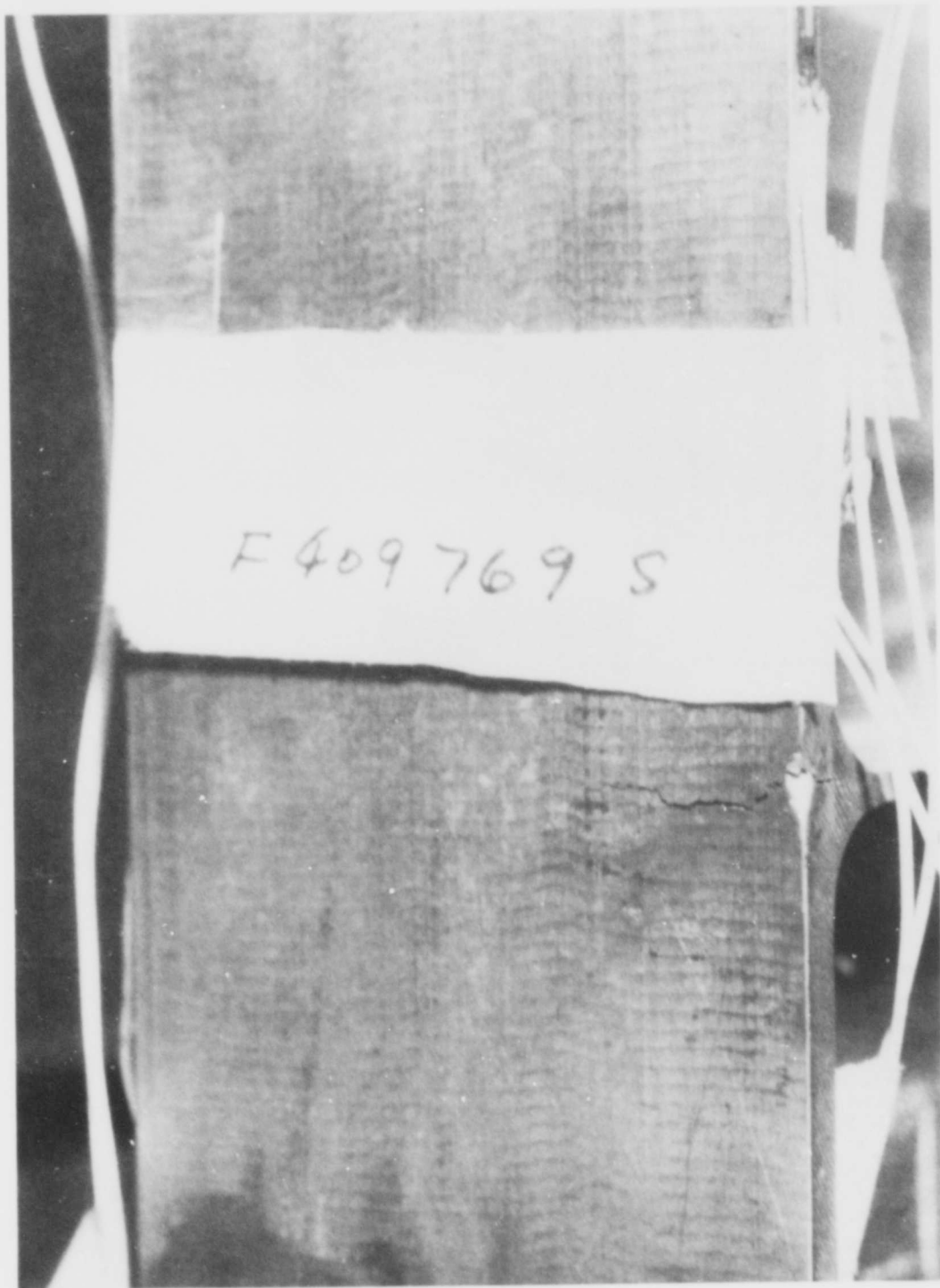

FIGURE F-14 TITANIUM I-BEAM FAILURE, S/N F409769

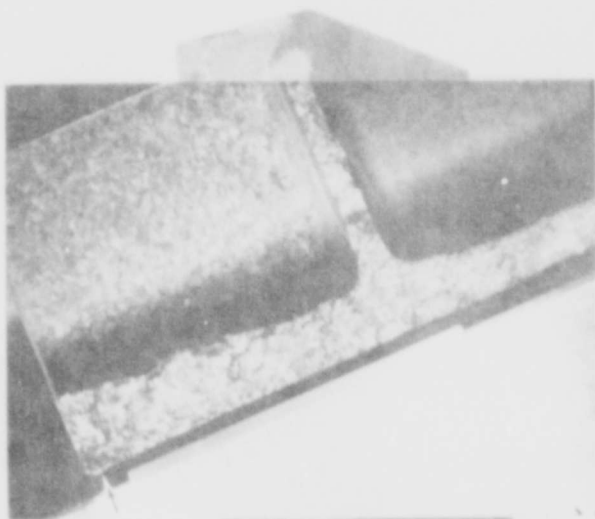

FIGURE F-15 TITANIUM I-BEAM FAILURE, S/N F409770

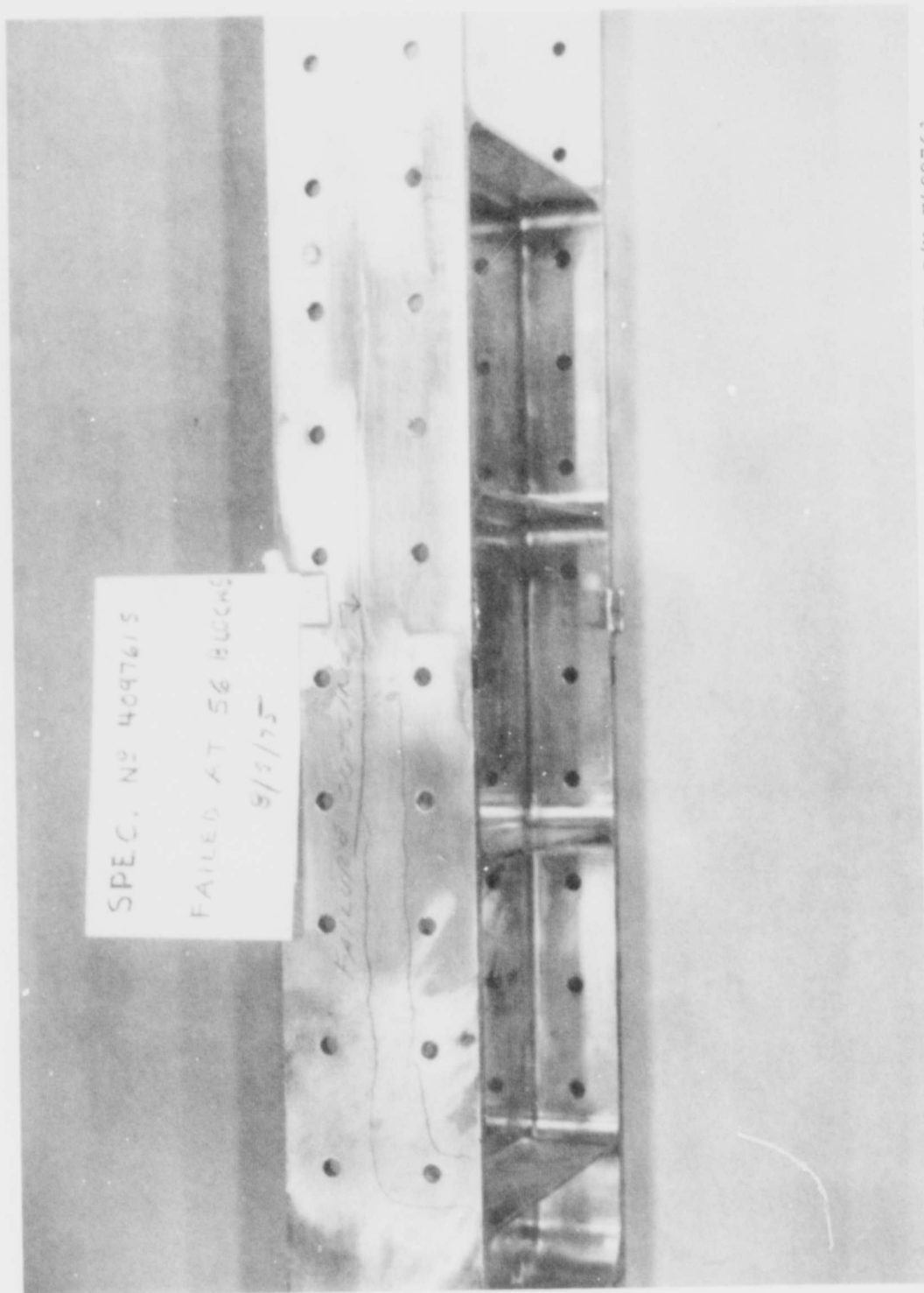

FIGURE F-16 ALUMINUM I-BEAM FAILURE, WITH FASTENER HOLES, S/N F409761

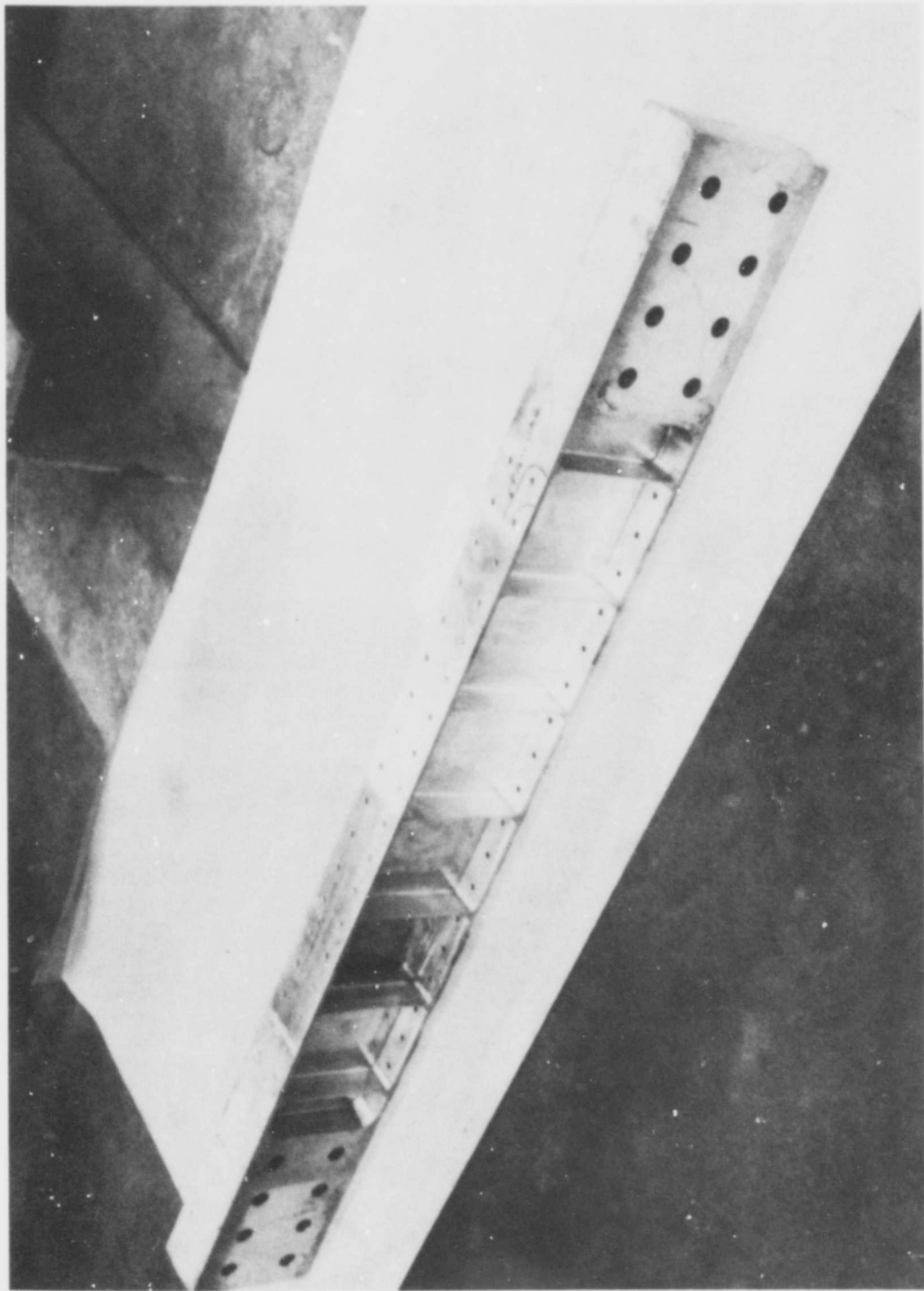

FIGURE F-17 ALUMINUM I-BEAM FAILURE, WITH FASTENER HOLES, S/N F409763

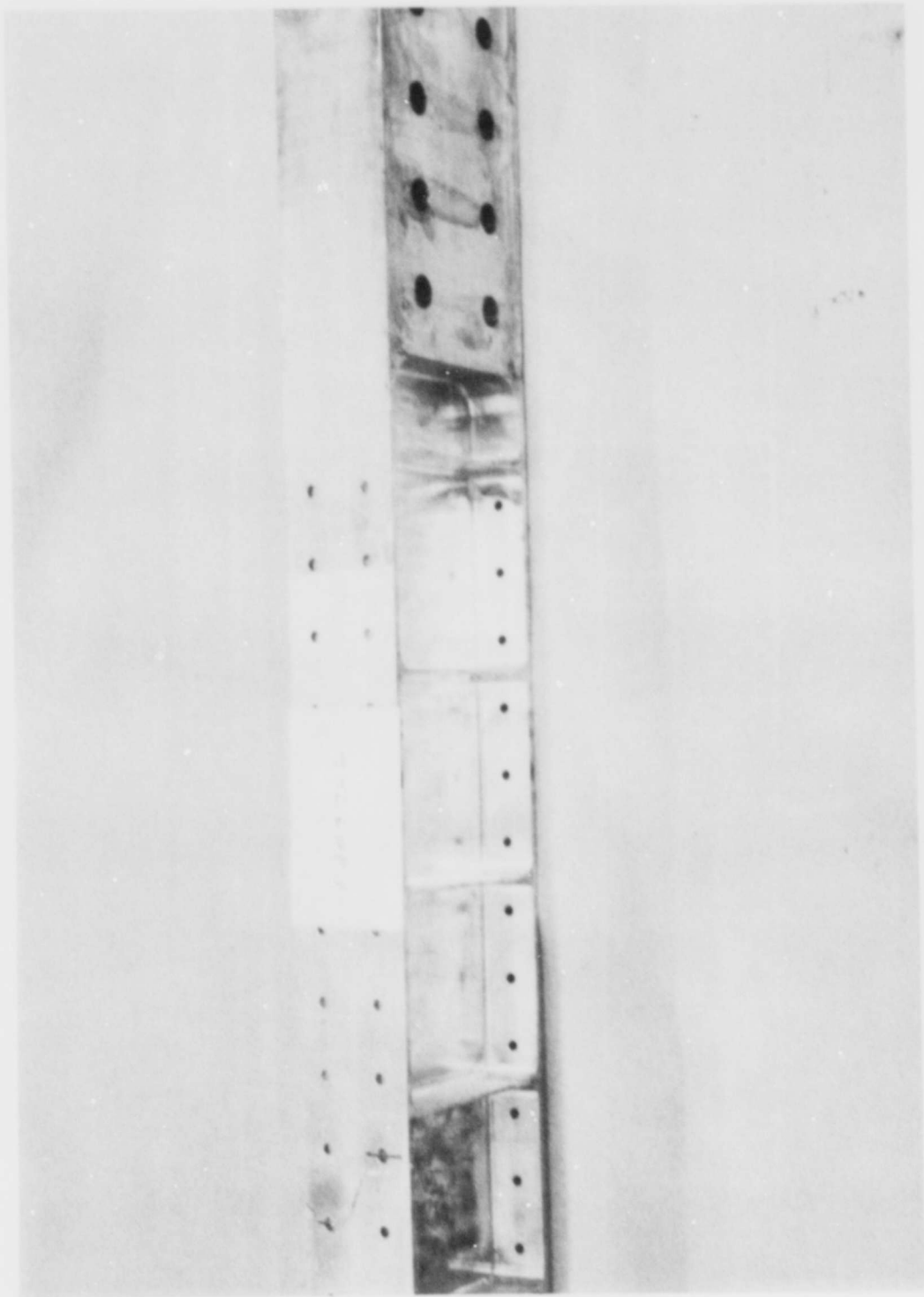

FIGURE F-18 ALUMINUM I-BEAM FAILURE, WITH FASTENER HOLES, S/N F409766

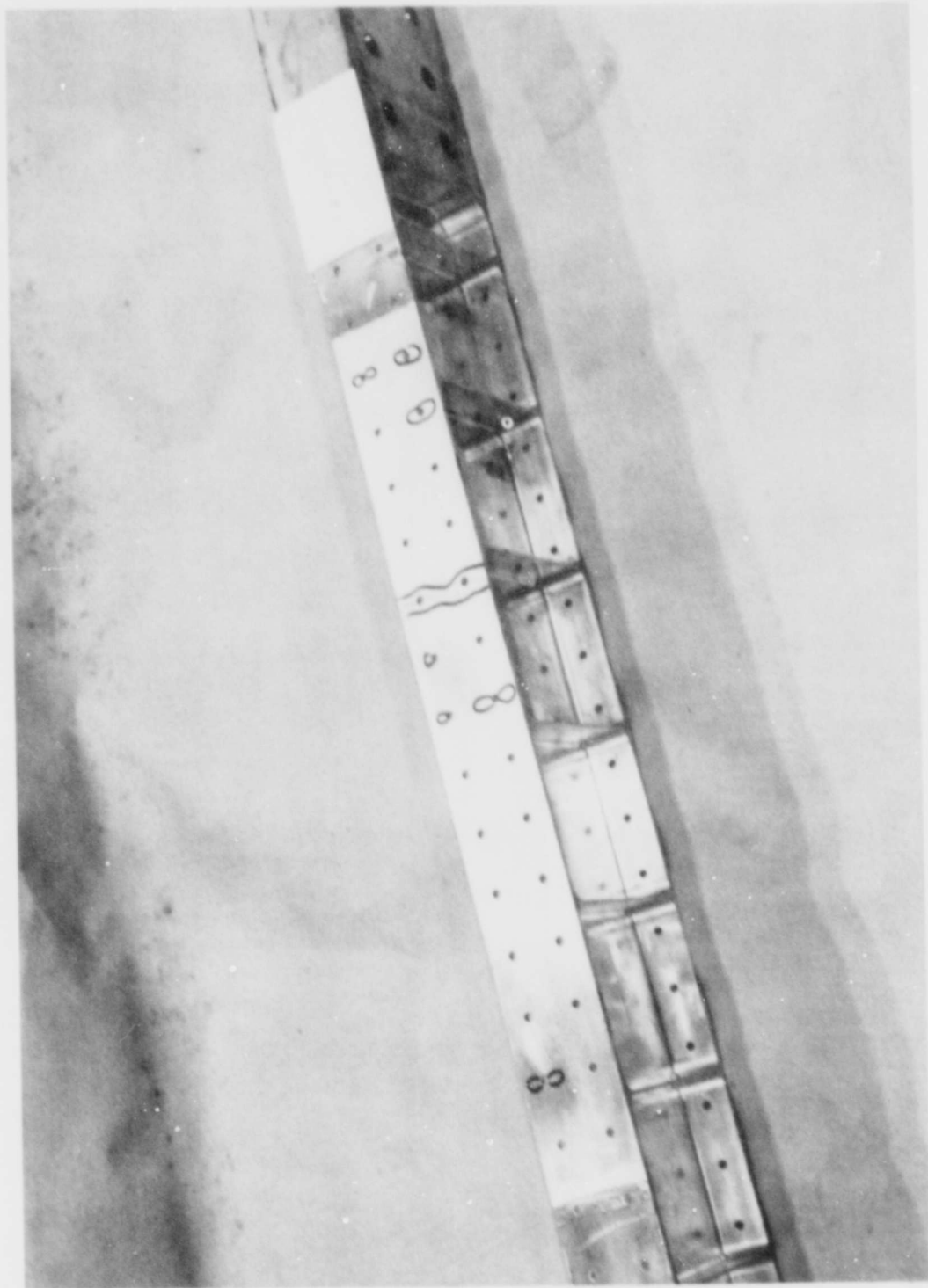

FIGURE F-19 ALUMINUM I-BEAM FAILURE, WITH FASTENER HOLES, S/N F411316

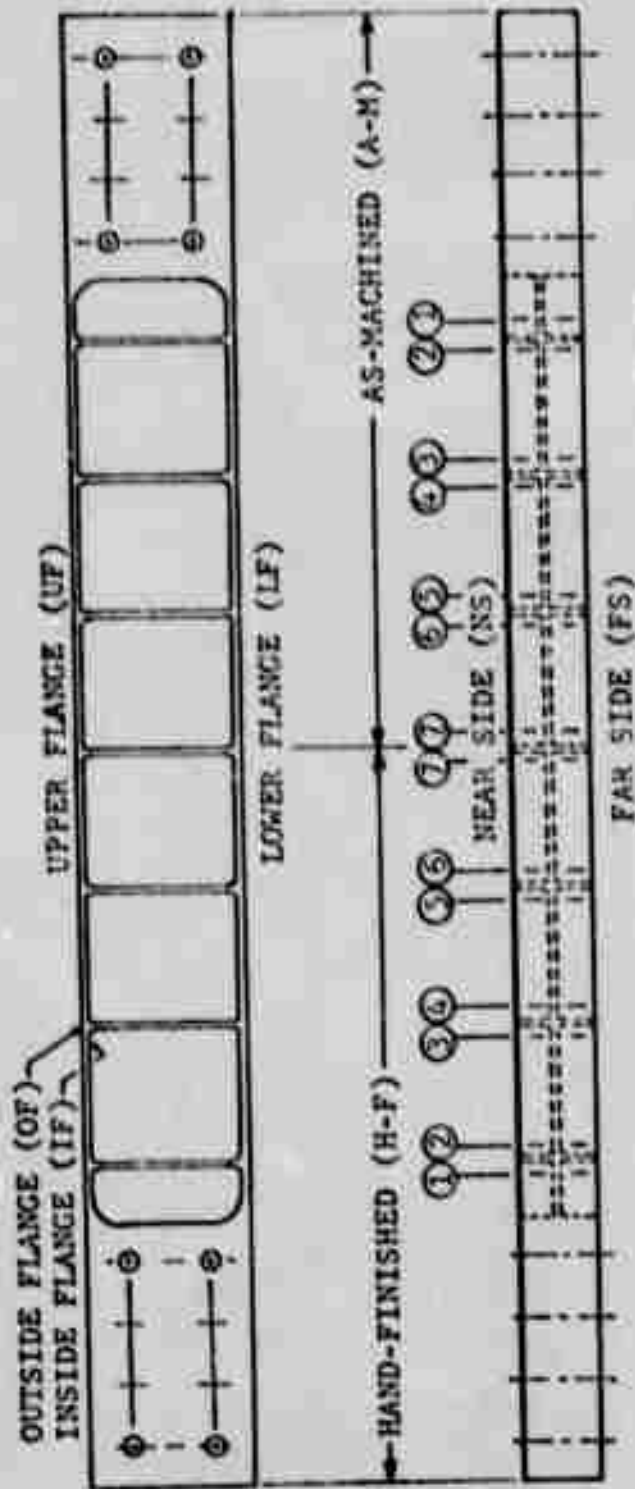

FIGURE F-20 I-BEAM FAILURE LOCATION SYSTEM

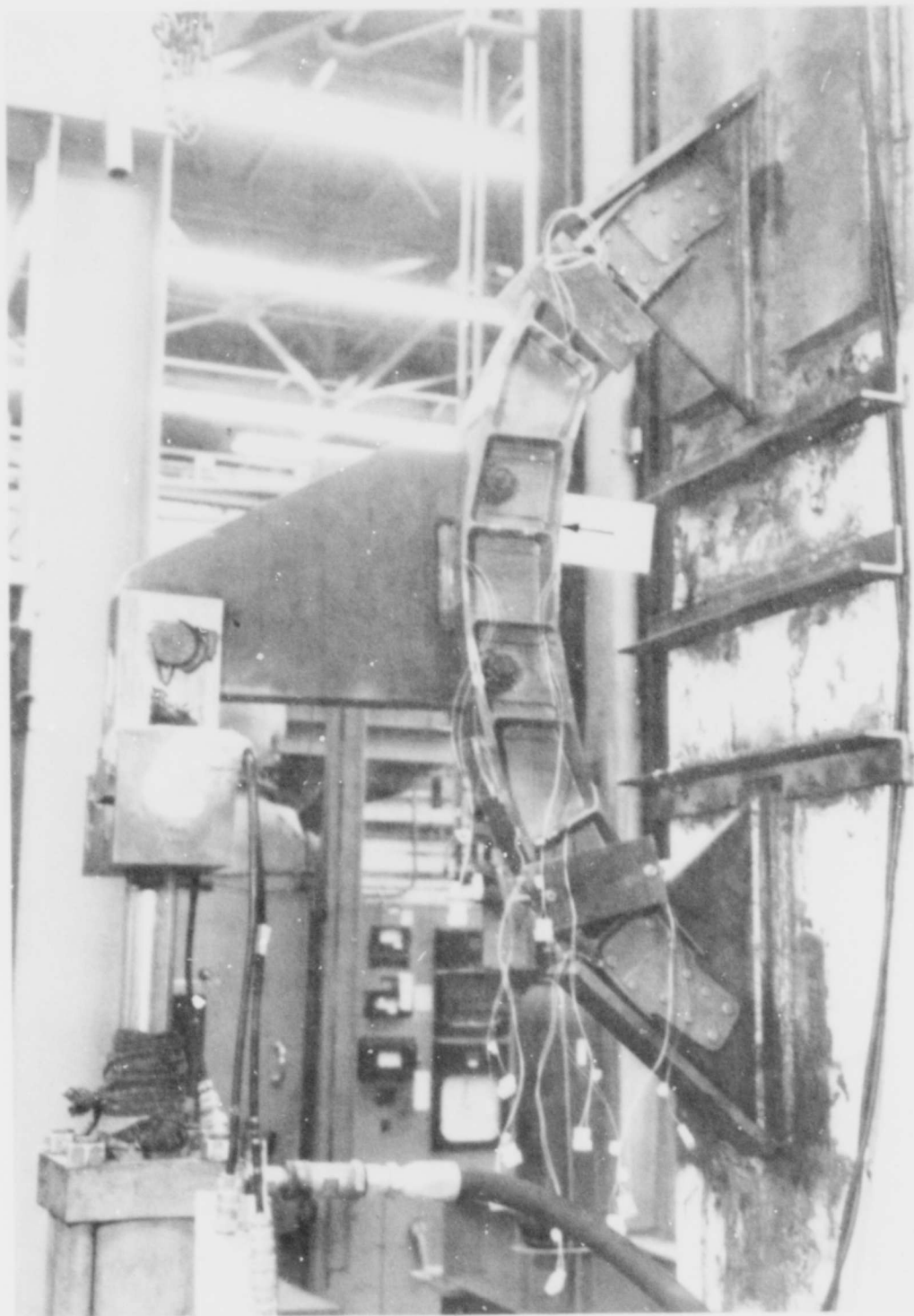

FIGURE F-21 YF-16 FRAME FAILURE

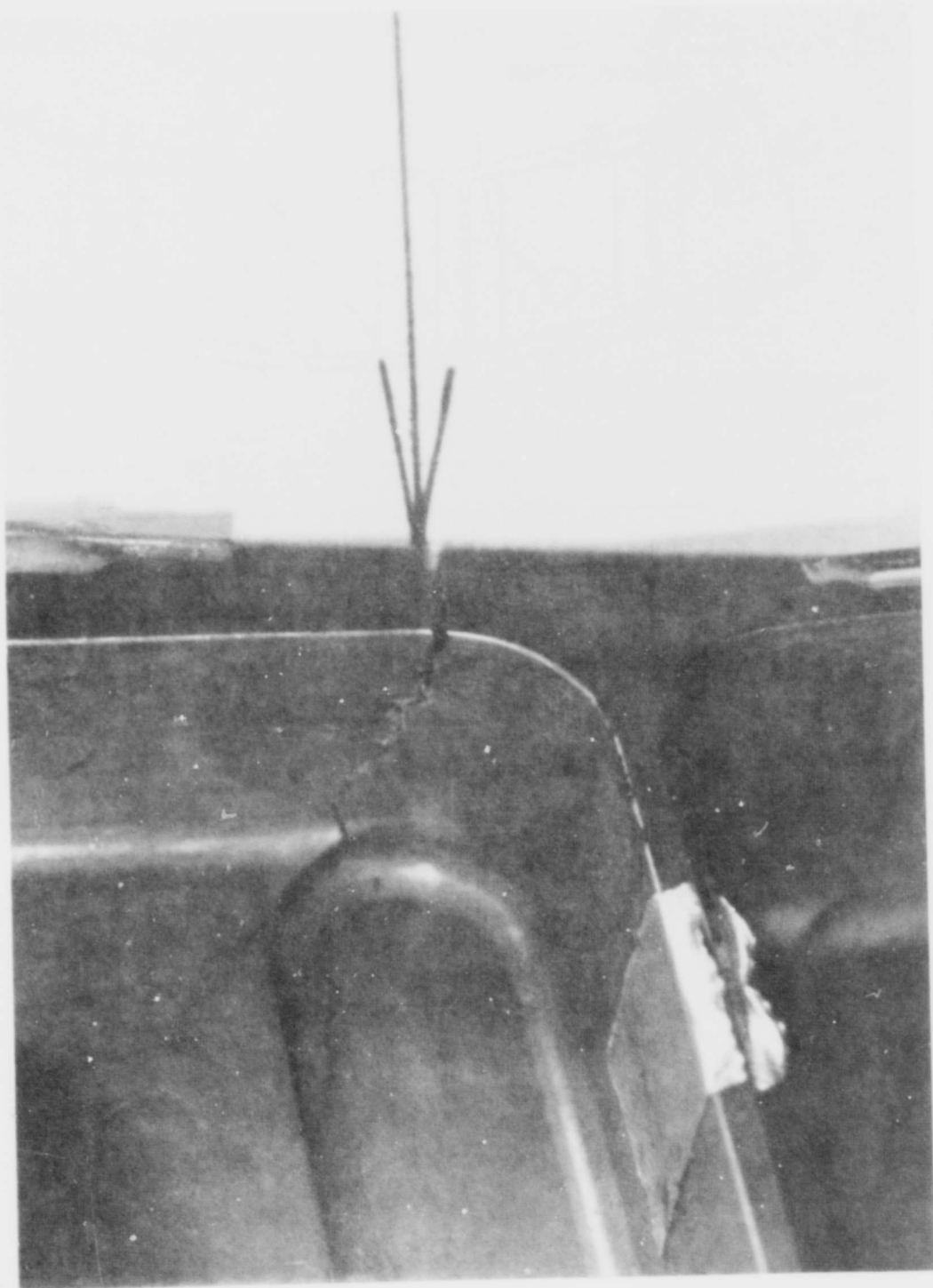

FIGURE F-22 YF-16 FRAME FAILURE - CLOSE UP

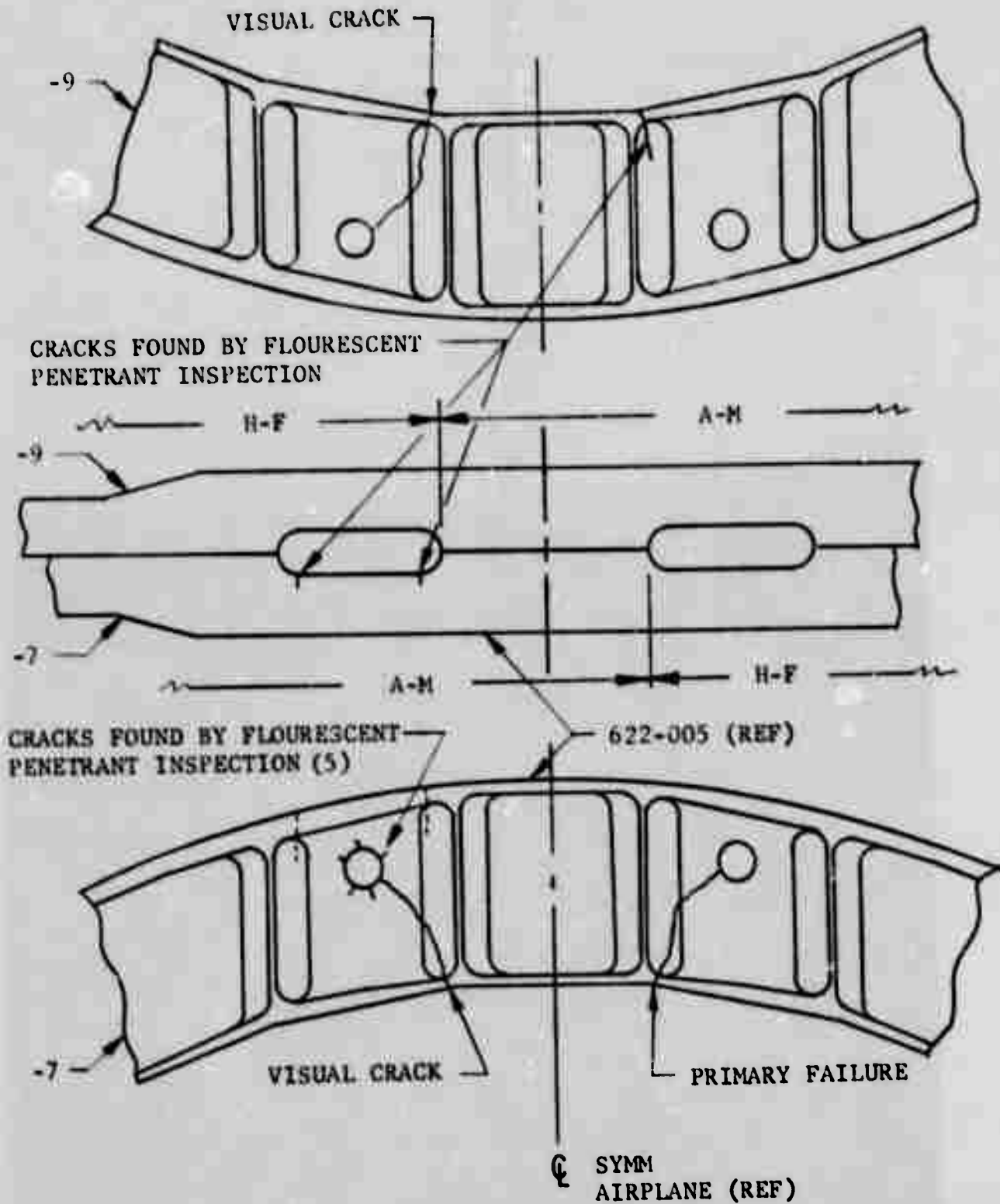

FIGURE F-23

YF-16 FRAME PENETRANT INSPECTION
CRACK DISCLOSURE

TABLE F-1
TEST DATA SUMMARY - ALUMINUM I-BEAM SPECIMENS

SPECIMEN S/N	MAT'L	TEST SPECTRUM	TEST STRESS SPECTRA (1)		TEST BLOCKS TO COMPLETE FAILURE @ ACTUAL STRESS	TEST BLOCKS TO CRACK INITIATION @ ACTUAL STRESS	MAX SPECTRUM DESIGN STRESS (KSI)	REF FIG.
			NOMINAL (KSI)	ACTUAL (KSI)				
755	ALUM	F-111	24	32.4	80	80	24	F-2
			45	60.8	40	40		
			30	30.0	33 (153)	10 (130)		
764	ALUM	F-111	24	32.4	80	59	24	F-3
			45	60.8	35 (113)			
759	ALUM	F-111	24	24	80	80	24	F-4
			45	45	40	40		
			30	30	145 (265)	82 (202)		
758	ALUM	F-111	30	30	205	205	24	F-5
			35	35	211	91 (296)		
			50	50	6 (422)			
762	ALUM	F-111	30	30	185	185	24	F-6
			35	35	183 (368)	44 (229)		
765	ALUM	F-16	35	35	280	183	30	F-8
			50	50	10 (290)			
757	ALUM	F-16	30	30	140	140	30	F-7
			35	35	119 (259)	17 (157)		
760	ALUM	F-16	35	35	144	101	30	F-9
			50	50	26 (170)			

NOTES: (1) The nominal stress is a typical section stress and the actual stress is that measured value at the critical section.

TABLE F-II
 TEST DATA SUMMARY - TITANIUM I-BEAM SPECIMENS

SPECIMEN S/N	MAT'L	TEST SPECTRUM	TEST STRESS SPECTRA (1)		TEST BLOCKS TO COMPLETE FAILURE @ ACTUAL STRESS	TEST BLOCKS TO CRACK INITIATION @ ACTUAL STRESS	MAX SPECTRUM DESIGN STRESS (KSI)	REF FIG.
			NOMINAL (KSI)	ACTUAL (KSI)				
768	Ti	F-16	90 94	77.4 126.9	30 41 (71)	30 41 (71)	68	F-10
767	Ti	F-16	94	126.9	28	28	68	F-11
771	Ti	F-16	94	126.9	32	32	68	F-12
772	Ti	F-16	87	117.5	62	29	68	F-13
769	Ti	F-16	94	94	35	35	68	F-14
770	Ti	F-16	68	91.8	121	62	68	F-15

NOTES: (1) The nominal stress is a typical section stress and the actual stress is that measured value at the critical section.

TABLE F-III
 TEST DATA SUMMARY - ALUMINUM I-BEAM SPECIMENS
 WITH 1/4" FASTENER HOLES

SPECIMEN S/N	MAT'L	TEST SPECTRUM	TEST STRESS SPECTRA (1)		TEST BLOCKS TO COMPLETE FAILURE @ ACTUAL STRESS	TEST BLOCKS TO CRACK INITIATION @ ACTUAL STRESS	MAX SPECTRUM DESIGN STRESS (KSI)	REF FIG.
			NOMINAL (KSI)	ACTUAL (KSI)				
761	ALUM	F-16	30	30	56	45	30	F-16
763	ALUM	F-16	30	30	65	57	30	F-17
766	ALUM	F-16	30	30	62	45	30	F-18
316	ALUM	F-16	30	30	48	35	30	F-19

NOTES: (1) The nominal stress is a typical section stress and the actual stress is that measured value at the critical section.

TABLE F-IV
ALUMINUM I-BEAMS - CRACK LOCATION AND ROUGHNESS

S/N	CRACK LOCATION (1)			SURFACE ROUGHNESS AT CRACK (μ IN., AA)	S. ROUGH. @ OPP. END (μ IN., AA)	COMMENT	
	LOC. NO. (4)	FINISH (4)	NEAR/FAR SIDE				
ALUMINUM 2124-T851 F-111 SPECTRUM, 24 KSI MAX. SPECTRUM STRESS LEVEL							
755	<u>1</u> <u>1</u>	A-M H-F	LF LF	NS --	IF IF	107 26-44 26-44	26-44 107-110
764	<u>1</u>	A-M	LF	--	IF	45-58	25-28
759	1 4 3	A-M A-M A-M	LF LF LF	-- -- NS	IF IF IF	37-51 35-54 50	29-36 31-35 33-35
762	<u>3-4</u>	H-F	LF	FS	OF	6	45-78
758	4 <u>4-5</u>	H-F A-M	UF UF	-- FS	IF IF	11-15 38-79	58-79 15-26
ALUMINUM 2124-T851 F-16 SPECTRUM, 30 KSI MAX SPECTRUM STRESS LEVEL							
757	(2-3)	(H-F)	UF	FS	OF	(2)	--
760	(2-3)	(A-M)	UF	NS	OF	(3)	16-25
765	2-3 <u>6</u>	A-M A-M	LF LF	-- NS	IF IF	41-69 102	13-21 16

- NOTES:
- (1) Location is correlated in Figure F-20.
 - (2) Failed due to notch caused in handling.
 - (3) Failed due to notch caused during doubt or installation.
 - (4) Underlined location indicates failure location.
 - (5) Number of primary failures in as-machined surfaces 5
in hand-finished surfaces 1
hand-finished surfaces 8
hand-finished surfaces 3
 - (6) Distribution of cracks: as-machined surfaces 5
hand-finished surfaces 1
hand-finished surfaces 8
hand-finished surfaces 3

TABLE F-V

TITANIUM I-BEAMS - CRACK LOCATION AND ROUGHNESS

S/N	CRACK LOCATION (1)				OUTSIDE/ INSIDE FLANGE	SURFACE ROUGHNESS AT CRACK (μ IN., AA)	S. ROUGH OPP. END (μ IN., AA)
	LOC. NO. (2)	FINISH (2)	UPR/LMR FLANGE	NEAR/ FAR SIDE			
TITANIUM 6Al-4Ti BETA ANNEALED F-16 SPECTRUM, 68 KSI MAX. SPECTRUM STRESS LEVEL (DESIGN)							
767	$\frac{1}{1}$ $\frac{1}{1}$ 1	<u>A-M</u> <u>H-F</u> A-M	UF UF LF	FS NS NS	IF IF IF	73 36 32	43 37 52
769	1 $\frac{1}{3-4}$	A-M <u>H-F</u> <u>H-F</u>	LF LF LF	FS NS NS	IF IF OF	30 55 34	30 57 100
769	$\frac{3-4}{1}$	<u>A-M</u>	UF	FS	OF	55	22
772	$\frac{1}{1}$	<u>H-F</u> <u>A-M</u>	UF UF	NS FS	IF OF	48 70	33 24
771	$\frac{1}{1}$	<u>A-M</u>	UF	NS	IF	44	23
770	$\frac{1}{1}$	<u>H-F</u> <u>A-M</u>	LF LF	FS NS	OF OF	34 60	55 34

- NOTES:
- (1) Location is correlated in Figure F-20.
 - (2) Underlined location indicates failure location.
 - (3) Number of primary failures in as-machined surfaces in hand-finished surfaces
 - (4) Distribution of cracks: as-machined surfaces hand-finished surfaces

TABLE F-VI
ALUMINUM I-BEAMS WITH FASTENER HOLES -
CRACK LOCATION AND ROUGHNESS

S/N (1)	NO. OF CRACKS AT FAILURE	NO. OF CRACKS IN		FAILURE LOCATION (2)					SURFACE ROUGHNESS AT FAILURE (μ IN., AA)
		H-F	A-M	LOC. NO.	FINISH	UPR/LWR FLANGE	NEAR/ FAR SIDE		
761	4	4	0	7	H-F	UF	NS		16
763	9	5	4	2	A-M	UF	NS		70
766	15	4	11	6-7	H-F	UF	NS		23
316	11	10	1	6	H-F	UF	NS		17
	(39)	(23)	(16)						

NOTES: (1) 2124-T851 aluminum with $\frac{1}{2}$ " drilled holes in each flange,
F-16 spectrum, 30 KSI max spectrum stress level.
(2) Location is correlated in Figure F-20.

A P P E N D I X G
FATIGUE ANALYSIS OF I-BEAM SPECIMENS

APPENDIX G
TABLE OF CONTENTS

	<u>Page</u>
1.0 NORMALIZING FATIGUE LIFE	209
2.0 FATIGUE NOTCH EFFECTIVENESS AND SENSITIVITY	210

APPENDIX G

LIST OF ILLUSTRATIONS

<u>Figure</u>		<u>Page</u>
G-1	Determination of Transfer Fatigue Stress Concentration Factor (K_{TR}) for Specimen S/N 767	212
G-2	Normalized Fatigue Life at Maximum Spectrum Design Stress for Specimen S/N 767	213

APPENDIX G
LIST OF TABLES

<u>Table</u>		<u>Page</u>
G-I	Fatigue Analysis Results of 2124-T851 Aluminum I-Beam Tests	214
G-II	Fatigue Analysis Results of 6AL-4V Beta Annealed Titanium I-Beams	215
G-III	Stress Concentration Effectiveness and Sensitivity, I-Beam Specimens	216

APPENDIX G

FATIGUE ANALYSIS OF I-BEAM SPECIMENS

The aluminum and titanium I-beams (without fastener hole concentrations) were necessarily fatigue tested to stress levels higher than the maximum spectrum design stresses to accelerate cracking and reduce test time. The fatigue analysis required to transfer the test results into data equivalent to testing at the maximum spectrum design stresses is presented herein. Also presented is data manipulation, the results of which represents the effectiveness and sensitivity of the specimen's stress concentration at the failure site.

1.0 NORMALIZING FATIGUE LIFE

Following is the method used to convert the fatigue life experienced at the actual test stress levels into an equivalent life as if tested at the maximum spectrum design stress level. Normalization was not required for the aluminum I-beams with fastener holes, since they were tested to the maximum spectrum design stress.

A metallurgical examination was conducted, as described in Appendix F, on each failed specimen to determine the point of crack initiation in terms of blocks of testing completed at time of crack initiation. Using this data in a computerized fatigue analysis program (UG9), the theoretical fatigue damage applied to each test specimen to the point of crack initiation was calculated. This computation was made for various fatigue stress concentration factors (K_T) utilizing the applicable F-111 200-hour block spectrum applied to the "actual" test stresses and combined with the appropriate S-N data and Miner's cumulative damage rule, i.e., $\sum n/N = 1.0$ at crack initiation. From the UG9 program output, plots were made of K_T versus applied theoretical fatigue damage. The effective K_T at crack initiation was read directly from each plot at $\sum n/N = 1.0$ (Miner's rule for failure). A sample plot for specimen S/N 767 is shown in Figure G-1. For the purpose of this analysis, this effective K_T will be addressed as a Stress Concentration Transfer Factor (K_{TR}), a factor required to transfer fatigue life from one spectrum stress level to another. It is not to be confused with an actual stress concentration.

Fatigue analyses were again computed, this time for a unitized 20 block test using the same F-111 200-hour or YF-16 400-hour block spectrum but at the maximum spectrum design stress level. These computations were also made utilizing the UG9 procedure for several K_T values. The resulting outputs were plotted in terms of K_T versus damage. A sample plot for specimen S/N 767 is shown in Figure G-2. From these plots a unit damage rate per block (n/N/BLOCK) of maximum spectrum design stress was established corresponding to the K_T equivalent in value to the transfer factor, K_{TR} , derived earlier. Thus for a damage of unity ($\sum n/N = 1.0$), the equivalent life in terms of blocks of maximum spectrum design stress was established.

The results of the fatigue analyses, in terms of damage per block and equivalent life at maximum spectrum design stress, are presented in Tables G-I and G-II. Supporting test data is also presented for reference information.

2.0 FATIGUE NOTCH EFFECTIVENESS AND SENSITIVITY

Geometric stress concentration factors (K_T) were determined for each specimen at the location of failure. For specimens with failure occurring in the load transition area, bay no. 1, the K_T was established as the ratio of the actual stress at this location to the nominal stress in a typical section of the beam. All specimens experienced a stress ratio of 1.35 in this area. Guidelines presented in "Stress Concentration Design Factors" by R. E. Peterson were used to assess the geometric concentrations applicable to the typical sections of the beams or the area of unloaded fastener holes. The resulting K_T factors were determined to be 1.1 and 2.8 respectively.

Based on the normalized fatigue life, described in paragraph 1.0, and using applicable S-N curves, the fatigue strength of each specimen was determined as if no concentration existed ($K_T = 1.0$) and also for the actual geometric concentration factors as explained above ($K_T = 1.1, 1.35$ or 2.8). The ratio of the fatigue strength without concentration (σ_n) to the fatigue strength with the specified concentration (σ_n') is defined as the fatigue strength reduction factor (K_f), i.e.,

$$K_f = \frac{\sigma_n}{\sigma_n'}$$

These values of K_f are a measure of the actual effectiveness of a stress concentration. They are, of necessity, calculated using σ_n and σ'_n values of maximum spectrum stresses. Table G-III tabulates the values of K_T , σ_n , σ'_n , and K_f for each specimen tested.

From the above data, the fatigue notch sensitivity factor, q , was derived and is defined as

$$q = \frac{K_f - 1}{K_T - 1}$$

The numerator represents the effectiveness of the notch in fatigue while the denominator represents its effectiveness in a purely elastic situation. The resulting notch sensitivity factor is an indication of the severity of the fatigue condition. The higher the value of q , the more severe is the fatigue condition and consequently represents a reduction in fatigue life. These values of q for each specimen are also presented in Table G-III.

See Section 4.2 of Volume I for an evaluation of the relationship between the fatigue notch sensitivity factors and the surface finish condition of the beams.

K_T	2.4	3.0	4.0	5.0
$\Sigma n/N$	3.3208	5.7463	14.3534	32.1681

28 BLKS @ 126.9 KSI

28 BLKS. @ CRACK INITIATION

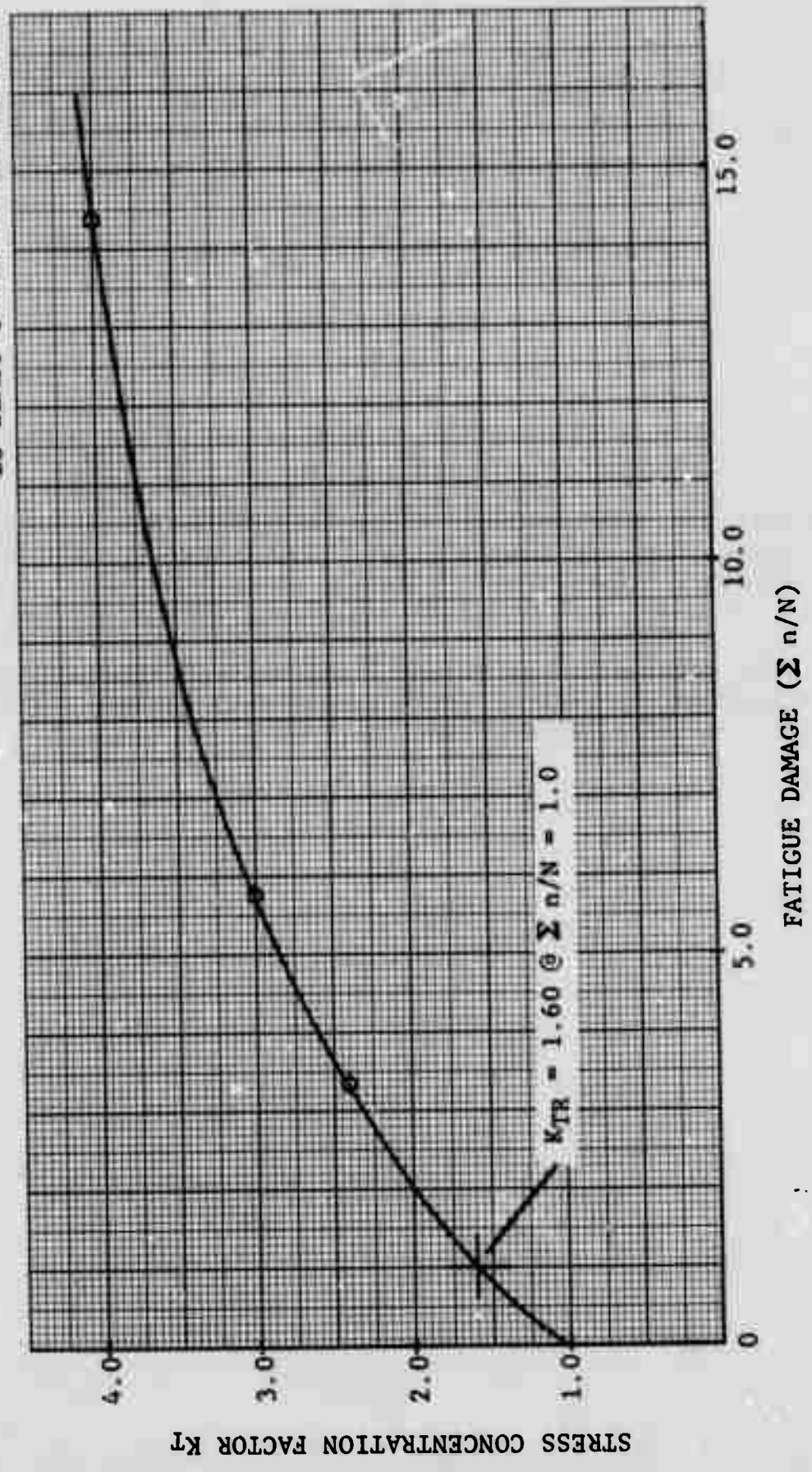

FIGURE G-1 DETERMINATION OF TRANSFER FATIGUE STRESS CONCENTRATION FACTOR (K_{TR}) FOR SPECIMEN S/N 767

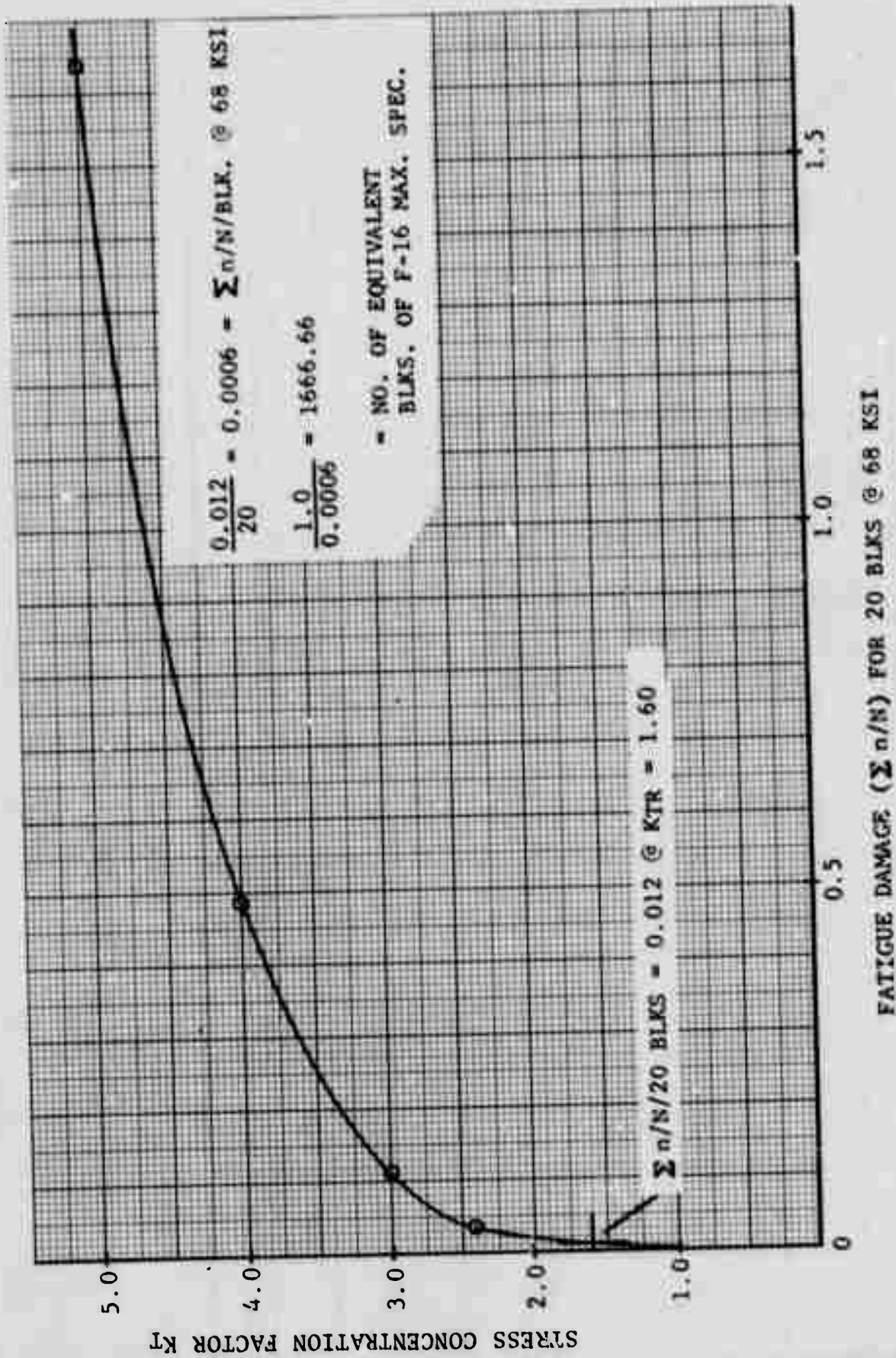

FIGURE G-2 NORMALIZED FATIGUE LIFE AT MAXIMUM SPECTRUM DESIGN STRESS FOR SPECIMEN S/N 767

TABLE G-1

FATIGUE ANALYSIS RESULTS OF
2124-T851 ALUMINUM I-BEAM TESTS

SPECIMEN S/N	MAT'L	TEST SPECTRUM	TEST STRESS (2)		TEST BLOCKS TO COMPLETE FAILURE @ ACTUAL STRESS	TEST BLOCKS TO CRACK INITIATION @ ACTUAL STRESS	MAX SPECTRUM DESIGN STRESS (KSI)	DAMAGE/BLOCK @ MAX SPECTRUM DESIGN STRESS ($\Sigma n/N$)	EQUIVALENT LIFE BASED ON MAX SPECTRUM DESIGN STRESS (BLOCKS) (1)
			NOMINAL (KSI)	ACTUAL (KSI)					
755	ALUM	F-111	24	32.4	80 40 33 (153)	80 40 10 (130)	24	0.0	∞
			45	60.8					
			30	30.0					
764	ALUM	F-111	24	32.4	80 35 (115)	59	24	0.00132	758
			45	60.8					
759	ALUM	F-111	24	24	80 40 145	80 40 82 (202)	24	0.0	∞
			45	45					
			30	30					
758	ALUM	F-111	30	30	205 211 6 (422)	205 91 (296)	24	0.000045	22,222
			35	35					
			50	50					
762	ALUM	F-111	30	30	185 183 (368)	185 44 (229)	24	0.000065	15,385
			35	35					
765	ALUM	F-16	35	35	280 10 (290)	183	30	0.00125	800
			50	50					
757	ALUM	F-16	30	30	140 119 (259)	140 17 (157)	30	0.00424	235
			35	35					
76C	ALUM	F-16	35	35	144 26 (170)	101	30	0.0022	455
			50	50					

NOTES: (1) These equivalent life values are for scatter factor = 1.0.

(2) The nominal stress is a typical section stress and the actual stress is that measured value at the critical section.

TABLE G-II
 FATIGUE ANALYSIS RESULTS OF
 6AL-4V BETA ANNEALED TITANIUM I-BEAMS

SPECTRUM S/N	MAT'L	TEST SPECTRUM	TEST STRESS (3) SPECTRA		TEST BLOCKS TO COMPLETE FAILURE @ ACTUAL STRESS	TEST BLOCKS TO CRACK INITIATION @ ACTUAL STRESS	MAX SPECTRUM DESIGN STRESS (KSI)	DAMAGE/BLOCK @ MAX SPECTRUM DESIGN STRESS ($2 \cdot n/N$)	EQUIVALENT LIFE BASED ON MAX SPECTRUM DESIGN STRESS (BLOCKS) (1)
			NOMINAL (KSI)	ACTUAL (KSI)					
768	T1	F-16	90	77.4	30	30	68	0.0005	2000
			94	126.9	41 (71)	41 (71)			
767	T1	F-16	94	126.9	28	28	68	0.0006	1667
771	T1	F-16	94	126.9	32	32	68	0.0005	2000
772	T1	F-16	97	117.5	62	29	68	0.0075 / 0.0005 (2)	1333 / 2000 (2)
769	T1	F-16	94	94	35	35	68	0.0005	2000
770	T1	F-16	68	91.8	121	62	68	0.0016 / 0.0010 (2)	625 / 1000 (2)

NOTES: (1) These equivalent life values are for scatter factor = 1.0.

(2) These damage and equivalent life values are based on ultimate failure.

(3) The nominal stress is a typical section stress and the actual stress is that measured value at the critical section.

TABLE G-III

STRESS CONCENTRATION EFFECTIVENESS AND SENSITIVITY,
I-BEAM SPECIMENS

BEAM S/N	MATL	K _T	σ _n	σ' _n	K _f	q	SURFACE FINISH	REMARKS
755	AL	1.35	37.2	35.80	1.0391	0.1117	AM	
764	AL	1.35	55.2	50.75	1.0877	0.2505	AM	
759	AL	1.10	37.2	36.75	1.0122	0.1224	AM	
758	AL	1.10	44.8	44.20	1.0136	0.1357	AM	
757	AL	1.10	55.5	51.25	1.0829	0.8293	HF	DAMAGED FLANGE
762	AL	1.10	45.7	45.00	1.0156	0.1556	HF	
765	AL	1.10	51.1	48.75	1.0482	0.4821	AM	
760	AL	1.10	52.8	49.80	1.0602	0.6024	AM	DAMAGED FLANGE
768	Ti	1.35	83.5	76.50	1.0915	0.2614	HF	
767	Ti	1.35	84.0	76.90	1.0923	0.2638	AM	
771	Ti	1.35	83.5	76.50	1.0915	0.2614	AM	
772	Ti	1.35	84.6	77.30	1.0944	0.2698	HF	
769	Ti	1.10	83.5	81.30	1.0271	0.2706	AM	
770	Ti	1.35	85.4	77.50	1.1019	0.2912	HF	
761	AL	2.80	43.8	30.00	1.4600	0.2556	HF	WITH FSTNR HOLES
763	AL	2.80	37.2	30.00	1.2400	0.1333	AM	WITH FSTNR HOLES
766	AL	2.80	43.8	30.00	1.4600	0.2556	HF	WITH FSTNR HOLES
316	AL	2.80	53.5	30.00	1.7833	0.4352	HF	WITH FSTNR HOLES

Reference Equations:

$$(1) K_f = \frac{\sigma_n}{\sigma'_n}$$

$$(2) q = \frac{K_f - 1}{K_T - 1}$$

A P P E N D I X H
S T A T I S T I C A L A N A L Y S I S

APPENDIX H
TABLE OF CONTENTS

	<u>Page</u>
1.0 DIMENSIONAL DEVIATION	220
2.0 I-BEAM FATIGUE TESTS	220
2.1 Aluminum I-Beams Without Fastener Holes	220
2.1.1 Effect of Surface Finish on Fatigue Cracks	223
2.1.2 Effect of Surface Finish on Surface Roughness	223
2.1.3 Effect of Surface Finish on Fatigue Life	225
2.2 Aluminum I-Beams with Fastener Holes	225
2.2.1 Effect of Surface Finish on Fatigue Cracks	225
2.2.2 Effect of Surface Finish on Surface Roughness	226
2.2.3 Effect of Surface Finish on Fatigue Life	228
2.3 Titanium I-Beams	228
2.3.1 Effect of Surface Finish on Fatigue Cracks	228
2.3.2 Effect of Surface Finish on Surface Roughness	228
2.4 Notch Sensitivity Evaluation	230
2.4.1 Aluminum I-Beams	230
2.4.2 Titanium I-Beams	230

APPENDIX H
LIST OF TABLES

<u>Table</u>		<u>Page</u>
H-I	Dimensional Deviation Statistical Analysis Summary	221
H-II	I-Beam Fatigue Test Summary	222
H-III	Surface Roughness - Aluminum I-Beams Without Holes - Inside Flanges	224
H-IV	Surface Roughness - Aluminum I-Beams With Holes - Inside Flanges	227
H-V	Surface Roughness - Inside Flanges of Titanium I-Beams	229

APPENDIX H

STATISTICAL ANALYSIS

The results of statistical analyses conducted on production part dimensional deviations and fatigue test data from I-beam specimen tests are presented in this appendix.

1.0 DIMENSIONAL DEVIATION

From the data obtained during the shop dimensional survey, described in Appendix B, Point and Interval Estimates were made for "deviation from nominal dimension." Three permissible tolerance limits for stiffeners and flanges and two for webs were assumed. The point estimate of the proportion of actual dimensions that would fall within the specified limits was then determined. Since this is an estimate of the proportion, the interval on the proportion was determined at both 95% and 99% confidence levels. The results of these analyses are presented in Table H-I.

It is to be noted that the data used in estimation of these proportions were collected when the specified deviation was ± 0.010 . If the permissible tolerances are relaxed on actual hardware as assumed, and if the manufacturing process changes as a result, the proportions estimated at the relaxed levels may be an overestimate.

2.0 I-BEAM FATIGUE TESTS

Results of the I-beam fatigue tests are summarized in Table H-II. These data are statistically analyzed in this section to determine the effect of surface finishing.

2.1 Aluminum I-Beams Without Fastener Holes

Eight aluminum I-beams without fastener holes were fatigue tested. Two of these specimens failed as a result of local damage and the results of these tests will be deleted from the following statistical analyses.

TABLE H-1
DIMENSIONAL DEVIATION STATISTICAL ANALYSIS SUMMARY

PART COMPONENT	SPECIFIED DEVIATION FROM NOMINAL	POINT ESTIMATE OF PROPORTION OF PROPORTION CONTAINED BETWEEN LIMITS	CONFIDENCE INTERVAL ON THE PROPORTION	
			95%	99%
STIFFENERS AND FLANGES	+ .010, - .010	.72	.690 - .750	.681 - .759
	+ .015, - .010	.88	.858 - .902	.852 - .908
	+ .015, - .005	.81	.786 - .834	.779 - .841
WEBS	+ .010, - .010	.95	.937 - .963	.933 - .967
	+ .015, - .010	.86	.837 - .883	.830 - .890

TABLE H-II

SUMMARY OF TEST RESULTS AT SITE OF FAILURE - I-BEAM SPECIMENS

S/N	MATERIAL	K _T (1)	MAX. SPECTRUM DESIGN STRESS (KSI)	SURFACE CONDITION AT FAILURE SITE		EQ'IV. BLOCKS TO INITIATION @ MSSL	TOTAL CRACKS		FATIGUE NOTCH (2) SENSITIVITY (q)	REMARKS
				TYPE	ROUGHNESS (μ IN., AA)		A-M	H-F		
759	AL	1.10	24	A-M	50	∞	3	0	.1224	
758	AL	1.10	24	A-M	38-79 (58.5)	22,222	1	1	.1357	
762	AL	1.10	24	H-F	6	15,385	0	1	.1556	
765	AL	1.10	30	A-M	102	800	2	0	.4821	
760	AL	1.10	30	A-M	19-28 (23.5)	455	1	0	.6024	DAMAGED FLG
757	AL	1.10	30	H-F	16-17 (16.5)	235	0	1	.8293	DAMAGED FLG
755	AL	1.35	24	A-M	107	∞	1	1	.1117	
764	AL	1.35	24	A-M	45-58 (51.5)	758	1	0	.2505	
763	AL	2.80	30	A-M	70	57	4	5	.1333	W/FSTNR HOLES
761	AL	2.80	30	H-F	16	45	0	4	.2556	W/FSTNR HOLES
766	AL	2.80	30	H-F	23	45	11	4	.2556	W/FSTNR HOLES
316	AL	2.80	30	H-F	17	35	1	10	.4352	W/FSTNR HOLES
769	Ti	1.10	68	A-M	55	2,000	1	0	.2706	
768	Ti	1.35	68	H-F	55	2,000	1	2	.2614	
771	Ti	1.35	68	A-M	44	2,000	1	0	.2614	
767	Ti	1.35	68	A-M	73	1,667	2	1	.2638	
772	Ti	1.35	68	H-F	48	1,333	1	1	.2698	
770	Ti	1.35	68	H-F	34	625	1	1	.2912	

NOTES: (1) Geometric stress concentration at failure site (Reference Appendix G).
 (2) Reference Appendix G.

2.1.1 Effect of Surface Finish on Fatigue Cracks

There were 8 fatigue cracks observed on the as-machined (A-M) surfaces and 3 cracks occurring on the hand-finished (H-F) surfaces. On the basis of this evidence, it can be concluded, with a confidence level of 89%, that cracks are more likely to occur on the A-M surfaces than on the H-F surfaces.

Of the critical cracks allowed to grow to failure, 5 occurred on the A-M surfaces and only 1 on the H-F surfaces. The results indicate that one can be 89% confident that failures are more likely to occur on the A-M surfaces.

To determine the relationship between cracks and their location along the beam, all the aluminum data (with and without fastener holes) has been pooled together to obtain a reasonable sample size for a chi-square statistical test. The results of this test is that there is no evidence to refute a random distribution of cracks across positions #1 through #7.

2.1.2 Effect of Surface Finish on Surface Roughness

Surface roughness measurements were taken throughout the length of the specimens and are shown according to the position on each beam in Table H-III. The average roughness on the H-F ends is 24.9 μ (in.) AA, while the average roughness on the A-M ends is 62.1 μ (in.) AA. Since the average roughnesses differ by so much relative to the variability observed within these two groups (A-M and H-F), one can be more than 99.9% confident that A-M surfaces are rougher than H-F surfaces for the type of I-beam specimens that this data represents. There is no indication of a trend in roughness by position along the beams.

The mean roughness at the 5 beam failure sites on the A-M ends is 71.0 compared to the mean roughness of 62.1 for all A-M surfaces. The difference is not large enough, with respect to the variability in roughness on the A-M ends, to be considered statistically significant at the 90% level ($t=1.5$).

Surface roughness measurements were obtained at the failure sites and also at the corresponding position on the opposite end of the beam. Of the 6 specimens analyzed, 5 failures occurred on the end of the beam that was the roughest. Based on this relationship, one can conclude, with a confidence of 89%, that failures are more likely to occur on rougher surfaces. Unfortunately, most of the roughest surfaces are on the A-M ends of

TABLE H-III
 SURFACE ROUGHNESS - ALUMINUM I-BEAMS WITHOUT HOLES-INSIDE FLANGES

BEAM S/N	H-F END							A-M END						
	POSITION NUMBER							POSITION NUMBER						
	1	2	3	4	5	6	7	1	2	3	4	5	6	7
764	23.5	24.0	25.25	22.5	24.75	25.5	22.75	32.5	35.25	32.5	34.75	38.25	39.75	43.75
755	43.5	49.0	47.25	53.5	46.5	47.0	33.0	90.5	112.25	112.75	113.0	114.5	109.75	110.75
759	31.25	36.25	37.75	36.25	33.0	32.75	35.0	45.0	47.0	44.5	41.25	46.75	45.25	43.75
762	12.0	14.25	14.50	13.75	15.0	13.25	11.25	61.75	56.5	45.75	61.75	58.0	57.75	65.0
758	14.5	15.75	15.5	13.5	20.25	16.50	18.5	66.75	65.25	56.25	64.0	65.0	59.75	81.75
765	13.0	15.0	18.25	16.0	15.75	14.5	14.75	71.0	64.25	57.75	56.75	51.0	56.0	51.75
MEAN	23.0	25.8	26.4	25.9	25.9	24.9	22.5	61.3	53.4	58.3	61.9	62.3	61.4	66.1
	MEAN H-F = 24.9							MEAN A-M = 62.1						
	STD DEV. = 7.03							STD DEV. = 13.00						

the beams. As a result, it cannot be determined whether it is the roughness or some other characteristic of the A-M surfaces that has led to more observed failures on A-M surfaces.

In addition to being rougher on the average, A-M surfaces display more variability of roughness than do H-F surfaces. The standard deviation for A-M surfaces is 13.0 as compared to 7.0 for H-F surfaces.

2.1.3 Effect of Surface Finish on Fatigue Life

No relationship between equivalent life and surface finish can be established from the data, regardless of whether the magnitudes of the equivalent life are used or simply the rank of the equivalent life are used.

2.2 Aluminum I-Beams with Fastener Holes

Four aluminum I-beams were fatigue tested with 36 fastener holes drilled in each flange. The unloaded fastener holes produced a stress concentration of 2.80 as compared to 1.10 for the beams without holes. As a result, all cracks and failure originated from these fastener holes.

2.2.1 Effect of Surface Finish on Fatigue Cracks

A X^2 contingency test indicates that one can be about 90% confident that the proportion of cracked fastener holes is larger on the H-F end than on the A-M end. The contingency table and test are set up as follows with all four specimens included:

	CRACKED HOLES	NOT CRACKED HOLES	TOTAL
H-F	23	49	72
A-M	16	56	72
TOTAL	39	105	144

The test static is $T=1.723$ which is referred to the X^2 distribution. The result is that one would expect a value of T as large or larger than 1.723 in only about 10% of the cases if the proportions were the same. Hence, one can be about 90% confident that a difference exists in the proportion.

A Smirnov test is appropriate to compare the two sets of crack location (A-M and H-F) data. The result is little evidence of any difference in where the cracks occur along the beam, comparing the as-machined and hand-finished ends. Disregarding the surface finish (A-M or H-F) of the beams, a χ^2 test indicates little or no evidence that cracks are likely to occur other than randomly across the beam.

Of the 4 critical cracks allowed to grow to failure, 3 occurred on the H-F end. A binomial test indicates "some" evidence that the probability of beam failure is larger on the H-F end. If both ends of the beam were equally likely to fail, the probability of failure on the H-F end would be 0.5. But since 3 of the 4 failures occurred on the H-F end, the point estimate is 0.75 for the probability of failure on the H-F end. This is an estimate and is subject to variability, but one can be about 69% confident that the probability of failure on the H-F end is larger than on the A-M end of the beam. It is to be noted that the small sample size makes it difficult to discern differences at high confidence levels. If the 3 to 1 ratio held it would require about 20 specimens to be 95% confident that the probability of failure on the H-F end is greater than on the A-M end.

2.2.2 Effect of Surface Finish on Surface Roughness

Surface roughness measurements were taken throughout the length of the specimens and are shown according to the position on each beam in Table H-IV. The average roughness on the H-F ends is $16.9 \mu(\text{in.})$ AA, while the average roughness on the A-M ends is $54.1 \mu(\text{in.})$ AA. Since the average roughnesses differ by so much relative to the variability observed within the two groups (A-M and H-F), one can be more than 99.9% confident that the A-M surfaces are rougher than H-F surfaces for the type of I-beam that this data represents. There is no indication of a trend in roughness by position along the beams.

The mean roughness at the failure sites on the A-M ends is 70.0, compared to the overall average roughness on the A-M ends of 54.1. The difference is not large enough to be statistically significant. On the H-F ends the mean roughness at failure sites is 17.33, compared to the overall mean roughness on the H-F ends of 16.9. This difference is also not large enough to be statistically significant.

TABLE H-IV
 SURFACE ROUGHNESS - ALUMINUM I-BEAMS WITH HOLES-INSIDE FLANGES

BEAM S/N	H-F END							A-M END						
	POSITION NUMBER							POSITION NUMBER						
	1	2	3	4	5	6	7	1	2	3	4	5	6	7
766	24.25	20.0	21.75	26.25	25.25	25.0	22.5	56.25	64.0	68.25	65.75	65.0	65.25	65.75
761	20.25	15.0	19.25	19.0	19.0	17.0	18.0	61.75	55.5	44.0	48.75	64.5	49.5	55.75
763	13.25	14.0	13.0	13.0	13.25	13.25	11.75	51.5	49.5	56.75	53.5	54.25	57.75	61.5
316	12.25	12.75	13.0	12.75	12.0	14.75	12.0	35.5	45.25	51.25	40.25	42.0	43.0	42.0
MEAN	17.5	15.4	16.8	17.8	17.4	17.5	16.1	51.3	53.6	55.1	52.1	56.4	53.9	56.3
	MEAN H-F = 16.9							MEAN A-M = 54.1						
	STD DEV. = 4.46							STD DEV. = 15.16						

2.2.3 Effect of Surface Finish on Fatigue Life

No relationship between fatigue life and surface finish can be established from the data, regardless of whether the magnitudes of the lives are used or simply the ranks of the lives are used.

2.3 Titanium I-Beams

2.3.1 Effect of Surface Finish on Fatigue Cracks

There were 7 cracks observed on the as-machined surfaces and 5 discovered on the hand-finished surfaces. The cracks responsible for failure were evenly divided, 3 on the A-M ends and 3 on the H-F ends. There is, therefore, little or no evidence to indicate that fatigue cracks are more likely to occur on either the A-M or H-F ends.

Most of the critical cracks occurred in position #1, with only one failure (A-M end) occurring elsewhere. Therefore it is concluded that there is no evidence to indicate that hand-finishing changes the location of failures across the beams. A X^2 test indicates 99.9% confidence that the cracks are not occurring at random across the beams. The stress concentration associated with position #1 is 1.35 as compared to 1.10 for all other locations. Position #1 accomodates load transition from the loading lug into the basic beam section.

2.3.2 Effect of Surface Finish on Surface Roughness

Surface roughness measurements were taken throughout the length of the specimens and are shown according to position on each beam in Table H-V. The average roughness on the H-F ends is 36.0 μ (in.) AA, while the average roughness on the A-M ends is 52.3 μ (in.) AA. Since the average roughnesses differ by so much relative to the variability observed within these two groups, one can be more than 99.9% confident that A-M surfaces are rougher than H-F surfaces for the type of I-beam that this data represents. There is no indication of a trend in roughness by position along the beams.

The mean roughness at the three failure sites on the A-M ends is 57.33, compared to the overall mean roughness of 52.3. The mean roughness of the three failure sites on the H-F ends is 45.67, as compared to the overall mean roughness of 36.0. The difference in roughness on the A-M ends is not large enough to be statistically significant, but the difference in roughness on the H-F ends is large enough to be statistically significant at 90% confidence level.

TABLE H-V
 SURFACE ROUGHNESS - INSIDE FLANGES OF TITANIUM I-BEAMS

BEAM S/N	H-F							A-M						
	POSITION NUMBER							POSITION NUMBER						
	1	2	3	4	5	6	7	1	2	3	4	5	6	7
771	34.25	36.0	32.5	27.75	30.5	28.5	22.5	72.25	66.25	68.5	70.5	63.0	65.0	73.5
770	30.5	26.0	36.0	34.0	30.25	29.0	30.25	51.5	52.25	48.75	47.25	44.75	49.0	44.75
769	41.5	33.5	33.75	37.75	38.5	34.5	36.0	52.75	45.5	57.0	49.25	46.50	40.25	41.75
768	44.25	38.5	39.25	41.75	43.5	42.25	38.75	50.25	50.0	50.5	46.5	52.0	48.0	43.25
767	45.25	39.5	42.25	38.0	38.25	45.5	44.0	58.75	51.25	46.0	51.5	52.5	52.0	70.5
772	39.5	29.5	39.0	29.75	39.25	32.75	32.0	46.5	44.5	42.0	47.25	46.75	47.0	48.25
MEAN	39.2	34.7	37.1	34.8	36.7	35.4	33.9	55.3	51.6	52.1	52.0	50.9	50.2	53.7
	MEAN H-F = 36.0							MEAN A-M = 52.3						
	STD DEV. = 9.17							STD DEV. = 22.21						

2.4 Notch Sensitivity Evaluation

The fatigue notch sensitivity factor (q) is an indication of the severity of the fatigue condition as explained in Appendix G. The higher the value of q the more severe is the condition. The fatigue notch sensitivity factors are listed in Table H-II.

2.4.1 Aluminum I-Beams

The correlation between surface finish (A-M vs. H-F) and the fatigue notch sensitivity at failure is $P=.272$. This correlation is weak and is not statistically significant.

The correlation between surface roughness at failure sites and fatigue notch sensitivity at failure sites is $-.076$. The correlation is very weak and is not statistically significant.

Several comparisons of fatigue notch sensitivity between surface finish groups (A-M or H-F) are appropriate. For specimens with a stress concentration (K_T) of 1.1, the difference in notch sensitivity at failure is between $-.3941$ and $.2119$ with 90% confidence. For specimens with a K_T of 2.80 (beams with fastener holes), the difference in notch sensitivity at failure is between $-.1208$ and $.4852$ with 90% confidence. No comparison can be made for specimens with a K_T of 1.35 since all failures occurred in the A-M surfaces. Combining all the aluminum data, the difference in notch sensitivity at failure is between $-.0999$ and $.2389$ with 90% confidence. None of the above comparisons of notch sensitivity between surface finish groups is statistically significant. Therefore it cannot be determined that either surface finish condition is more critical than the other.

2.4.2 Titanium I-Beams

The correlation between fatigue notch sensitivity at failure and surface finish condition (A-M or H-F) is $P=.501$. This value is not large enough to be statistically significant.

The correlation between fatigue notch sensitivity at failure and measured surface roughness is $P=-.63$. The value is not large enough to be significant at 90% confidence level but is significant at 80% confidence level. The value of the correlation becoming increasingly negative means that as the surface roughness increases, the fatigue notch sensitivity decreases.

Two other comparisons of fatigue notch sensitivity between surface finish groups (A-M vs. H-F) can be made. For specimens with a stress concentration (K_T) of 1.35, the difference in the notch sensitivity is between $-.0106$ and $.0336$ with 90% confidence. No comparison can be made for the K_T of 1.10 since only one specimen had this concentration. Combining all the titanium data, the difference is $-.0110$ and $.0286$ with 90% confidence. None of the above differences are large enough to be statistically significant. Therefore it cannot be determined that either surface finish condition is more critical than the other.

A P P E N D I X I
S U R F A C E R O U G H N E S S R E Q U I R E M E N T S

PRECEDING PAGE BLANK

APPENDIX I
TABLE OF CONTENTS

	<u>Page</u>
1.0 SURFACE ROUGHNESS REQUIREMENTS AND DEFINITIONS	236
2.0 INTERPRETATION OF ROUGHNESS READINGS	238
3.0 GENERAL DYNAMICS CORPORATE SPONSORED RESEARCH ON ROUGHNESS	239
4.0 METCUT RESEARCH ASSOCIATES TEST DATA	240
5.0 RELAXED TOLERANCE CONCEPTS PROGRAM IMPLEMENTATION	240

APPENDIX I

LIST OF ILLUSTRATIONS

<u>Figure</u>		<u>Page</u>
I-1	Fatigue Test of 7075-T6 Aluminum Alloy Cut with Side of End Mill at Mean Stress of 0 KSI	241
I-2	Fatigue Test of 7075-T6 Aluminum Alloy Cut with Side of End Mill at Mean Stress of 20 KSI	242
I-3	Fatigue Test of 7079-T651 Aluminum Alloy Cut with End of End Mill at Mean Stress of 0 KSI	243
I-4	Fatigue Test of 7079-T651 Aluminum Alloy Cut with End of End Mill at Mean Stress of 20 KSI	244
I-5	Milled Surface Finish vs. Fatigue Strength Correlation	245
I-6	Surface Roughness and Tolerances for Machined Surfaces - Standard for Inspection	246

APPENDIX I

SURFACE ROUGHNESS REQUIREMENTS

1.0 SURFACE ROUGHNESS REQUIREMENTS AND DEFINITIONS

The method of constructing airframe structural components such as spars, bulkheads, longerons, beams, etc. has changed from built-up sheet metal and extrusions to monolithic structure sculptured from thick plate; therefore, the amount of machined surfaces in an airplane has increased tremendously. Numerically controlled milling machines are used extensively to cut the flat surfaces forming the webs with the end of an end mill and the outstanding flanges are formed with the side of the end mill. These structural parts are subject to cyclic loading, and if they are designed efficiently, they must be termed "fatigue critical."

Machining and inspecting these fatigue critical parts was becoming a problem in the B-58 airplane, but the F-111 airplane focused attention on the problem. The initial Air Force requirements for the F-111 airplane required that all "fatigue critical" machined surfaces be finished to a 63 or less microinch average roughness height per MIL-STD-10A*. At the same time, more numerically controlled mills were being used to form one-piece components; this made the surface finish requirement costly. After negotiation, the specification was modified to allow a 125 microinch average roughness height on fatigue critical parts that were subsequently shot peened.

In 1969 the AFSC Design Handbook was issued stating these same finish requirements. The 1970 version added that surfaces should be free of defects, as follows:

"4. Surface Roughness

In predicting useful life, consider surface roughness of individual components that are subject to repeated stresses, the tension component of which is 50% of the material

*MIL-STD-10A prepared from ASA-B46.1-1955
MIL-STD-10A superceded by ASA B46.1-1962
ASA B46.1 designation changed to USAS B46.1-1962
USAS B46.1 designation changed to ANSI B46.1-1962

specification minimum yield strength or higher, using applicable stress concentration factors. Those components considered to be critical in fatigue must have a surface roughness not to exceed 63 AA (arithmetical average) as defined by ANSI B46.1 or must be shot peened, with a surface roughness prior to peening not to exceed 125 AA. Surface should be free of defects such as gouges, tool marks, scratches, or similar surface imperfections."

This paragraph remains unchanged in the April 1975 edition of the AFSC Design Handbook:

Surface roughness is evaluated per ANSI B46.1 in terms of an arithmetical average height. The average roughness includes only the surface topology generated by the cutting tool.

The following paragraphs from ANSI B46.1 should be considered when discussing surface roughness.

Paragraph 2.6 "Roughness. Roughness consists of the finer irregularities in the surface texture usually including those irregularities which result from the inherent action of the production process. These are considered to include traverse feed marks and other irregularities within the limits of the roughness-width cutoff."

Paragraph 2.9 "Flaws. Flaws are irregularities which occur at one place or at relatively infrequent or widely varying intervals in a surface. Flaws include such defects as cracks, blow holes, checks, ridges, scratches, etc. Unless otherwise specified, the effect of flaws shall not be included in the roughness height measurements."

Paragraph D-4 "Working surfaces such as bearings, pistons, and gears are typical of surfaces for which optimum performance may require control of the surface characteristics in accordance with the procedure outlined in the foregoing

standard. Nonworking surfaces such as the walls of transmission cases, crank cases, or differential housing seldom require any surface control such as that with which this standard is concerned, the only exceptions in these instances being restrictions that may be necessary for process control and finish required for sake of appearance."

2.0 INTERPRETATION OF ROUGHNESS READINGS

Arithmetic average roughness height rating per ANSI B46.1 cannot be used as a criterion for measuring the resistance of a part to fatigue failure. To illustrate this, consider a surface generated by the side of an end mill. If aluminum alloy is being cut, it is economical to increase the machining feed rate to the extent that a fluted surface will result as shown in the exaggerated sketch below.



The radius of the notch is large and is, in effect, the radius of the cutter. Theoretical and photoelastic stress analysis show that the large radius causes a low stress concentration and that the peaks have little or no influence on the stress at the bottom of the notch. In other words, removing the tops of the peaks will change the roughness height rating but it will not alter the stress at the bottom of the notch.

Now, consider the surface finish pattern to be an exact inversion of the previous pattern.



The arithmetic average roughness height rating is exactly the same as that for the surface shown previously. However, the notch has a sharp root radius that results in a high stress concentration factor. Fatigue cracks originate at the points of highest stress. The high stress concentration caused by the sharp notch will lower the fatigue life much below the fatigue life for the rounded notch shown in the first illustration. Thus, a wide range of surface profiles can have a wide range of stress concentration and resulting fatigue lives even though the arithmetic average roughness height rating is identical.

3.0 GENERAL DYNAMICS CORPORATE SPONSORED RESEARCH ON ROUGHNESS

Actual test data confirms that there is little or no correlation of fatigue life with arithmetic average roughness height rating. Studies conducted at General Dynamics Fort Worth Division by O. N. Thompson on aluminum alloys and steel demonstrate this point. Uniaxial flat fatigue test specimens (dog bones) were machined and tested to failure in tension-tension cyclic loading. Specimens cut from 0.125-inch-thick aluminum alloy were machined on one side only with the side of an end mill. The "as-rolled" plate was used as a reference for comparison. This finish is representative of the finish generated by an end mill creating an outstanding leg while pocket milling. The roughness was varied over a wide range by controlling the feed rate. The results of the test conducted at zero mean stress are shown in Figure I-1. Likewise, the results obtained when the stress was cycled about 20,000 pounds per square inch mean stress are shown in Figure I-2.

The curves shown are median curves through the data points. There is no definite trend separating the various finishes according to their arithmetic average roughness height rating.

Fatigue life of specimens machined and then shot peened appeared to be improved in the 10^4 to 10^5 cycle range, but shot peening lowered the endurance limit as shown in Figure I-2.

Note the dotted $K_T = 3$ curve. This curve represents the fatigue life when a hole is drilled into a part. Almost every part has holes that are used to attach it to adjacent structure. The fatigue life variations caused by variations in surface finish are insignificant when they are compared to the amount of fatigue life loss caused by an ordinary fastener hole.

The end of an end mill was used to cut 0.06-inch-thick fatigue specimens from the center of a 2.5-inch-thick 7079 aluminum alloy plate. These specimens represent the finish obtained on the web of an integrally stiffened bulkhead created by pocket milling. The results of these tests are shown in Figure I-3 for specimens tested at zero mean stress and in Figure I-4 for specimens tested at 20,000 psi mean stress. The conclusions drawn from these S-N curves for finishes created by the end of an end mill agree with the conclusions drawn from the S-N curves for finishes created by the side of an end mill.

4.0 METCUT RESEARCH ASSOCIATES TEST DATA

Dr. Wm. P. Koster of Metcut Research Associates, Inc. of Cincinnati, Ohio, conducted an extensive program for the Air Force Materials Laboratory on "Surface Integrity of Machined Materials" published in 1974 in AFML-TR-74-60. Figure I-5 illustrates the data generated relative to the effects of gentle and abusive milling with the end of an end mill on 7075-T7351 aluminum and annealed 6Al-4V titanium. On aluminum, there is no correlation between surface finish or measured roughness in the direction of stress and the resulting 10 endurance limit for either gentle or abusive milling. The same is true for the titanium alloy although titanium appears to have a sensitivity to lay direction.

5.0 RELAXED TOLERANCE CONCEPTS PROGRAM IMPLEMENTATION

The early tests on tension coupons described in paragraph 3.0, the Metcut Research data, of paragraph 4.0, and the RTC I beam tests described in Appendices F and G were conclusive evidence to F-16 Engineering that the roughness requirements on milled aluminum could be substantially relaxed.

As a result, the inspection standard for machined parts was revised by RTC program personnel to delete all surface roughness engineering/inspection requirements for aluminum on all surfaces of milled or routed parts, except for contact surfaces. For contact surfaces, wave height and width requirements were also deleted. At present it is required only that contact surfaces have no more than 125 AA roughness and 0.003 inches mismatch. All other surfaces have no roughness limit and a mismatch limit based on the plus/minus dimensional tolerance. Such mismatches are limited in radius to prevent notch effects. Figure I-6 illustrates the revised requirements.

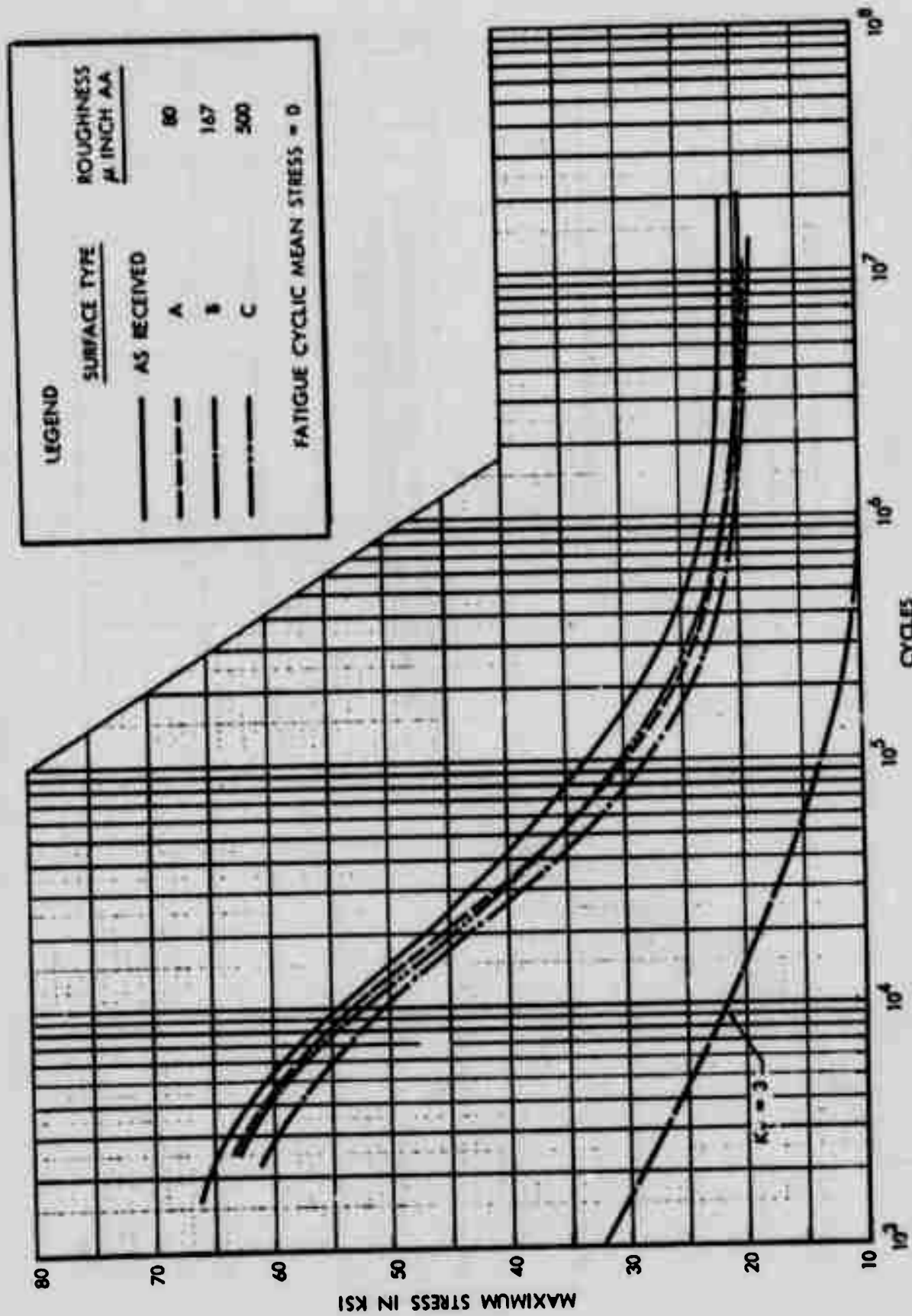

FIGURE I-1 FATIGUE TEST OF 7075-T6 ALUMINUM ALLOY CUT WITH SIDE OF END MILL AT MEAN STRESS OF 0 KSI

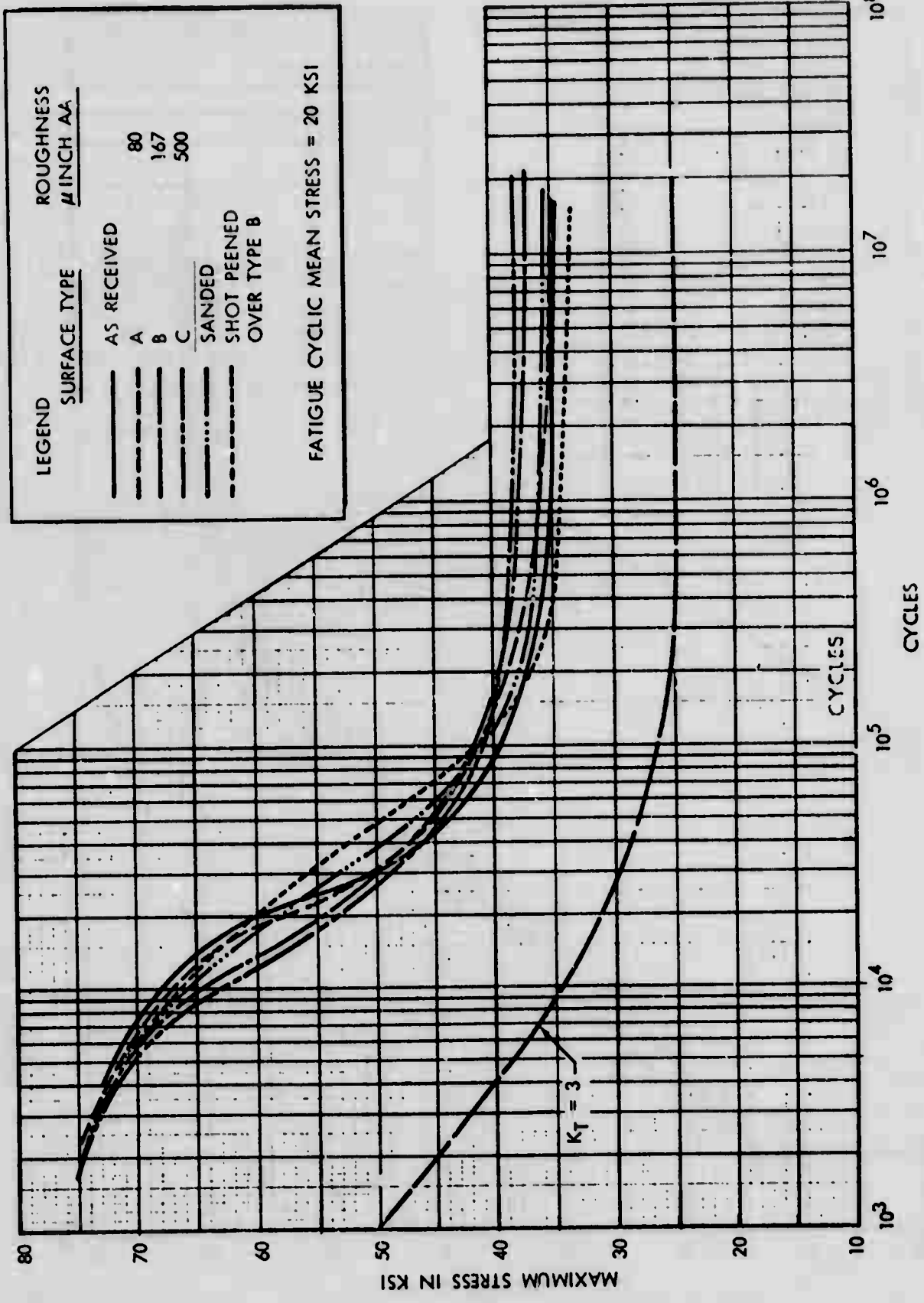

FIGURE I-2 FATIGUE TEST OF 7075-T6 ALUMINUM ALLOY CUT WITH SIDE OF END MILL AT MEAN STRESS OF 20 KSI

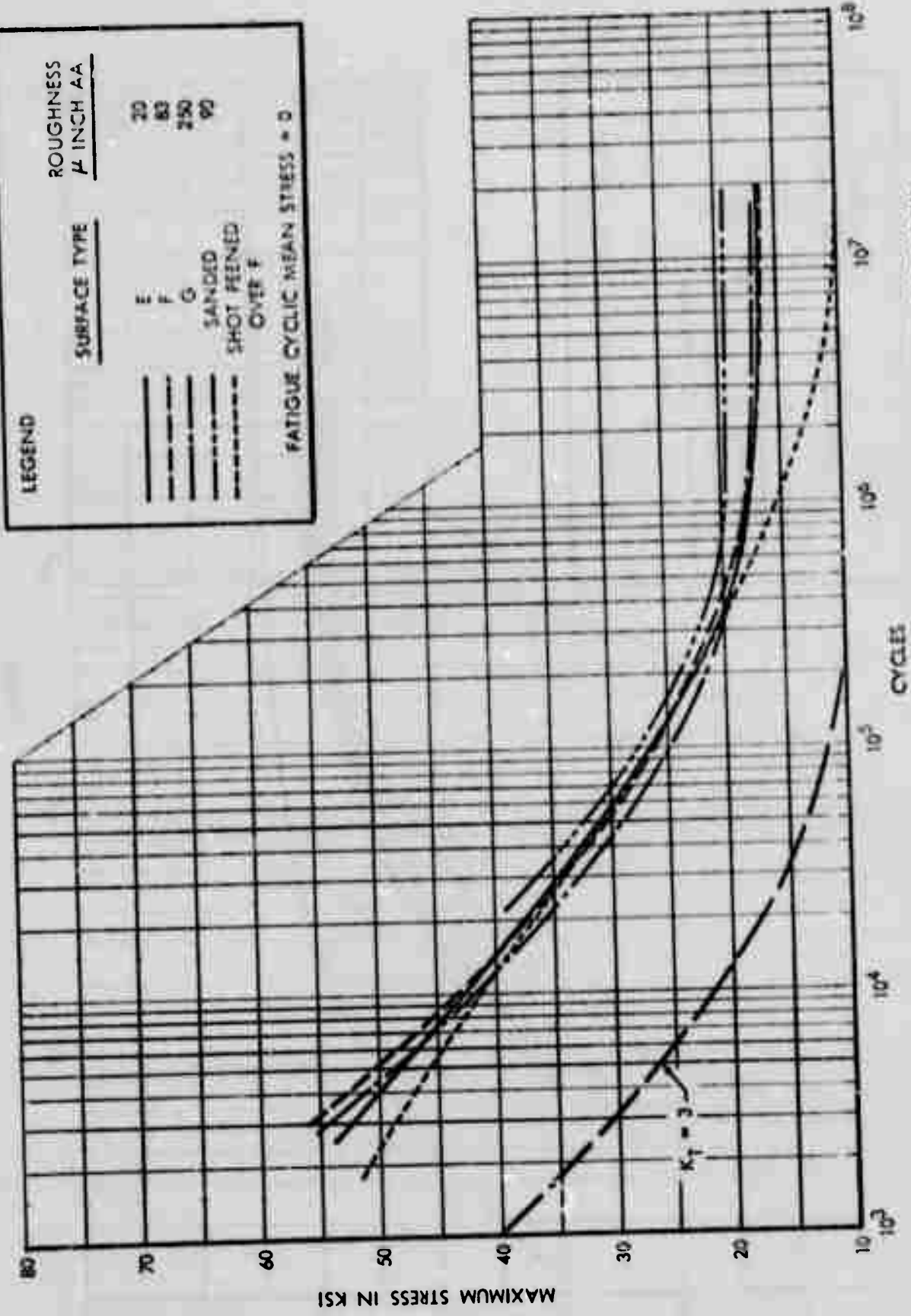
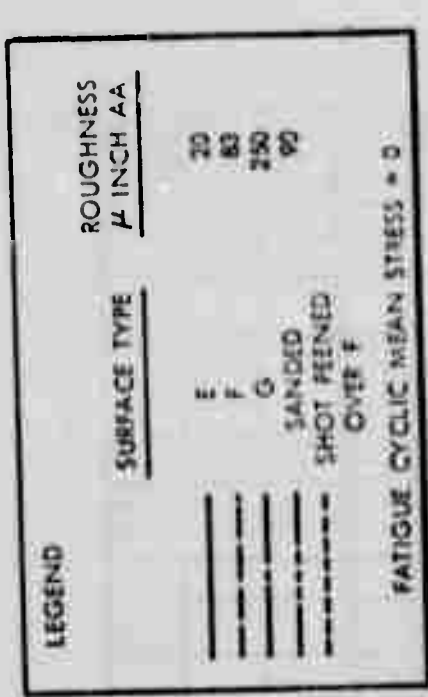

FIGURE 1-3 FATIGUE TEST OF 7079-T651 ALUMINUM ALLOY CUT WITH
END OF END MILL AT MEAN STRESS OF 0 KSI

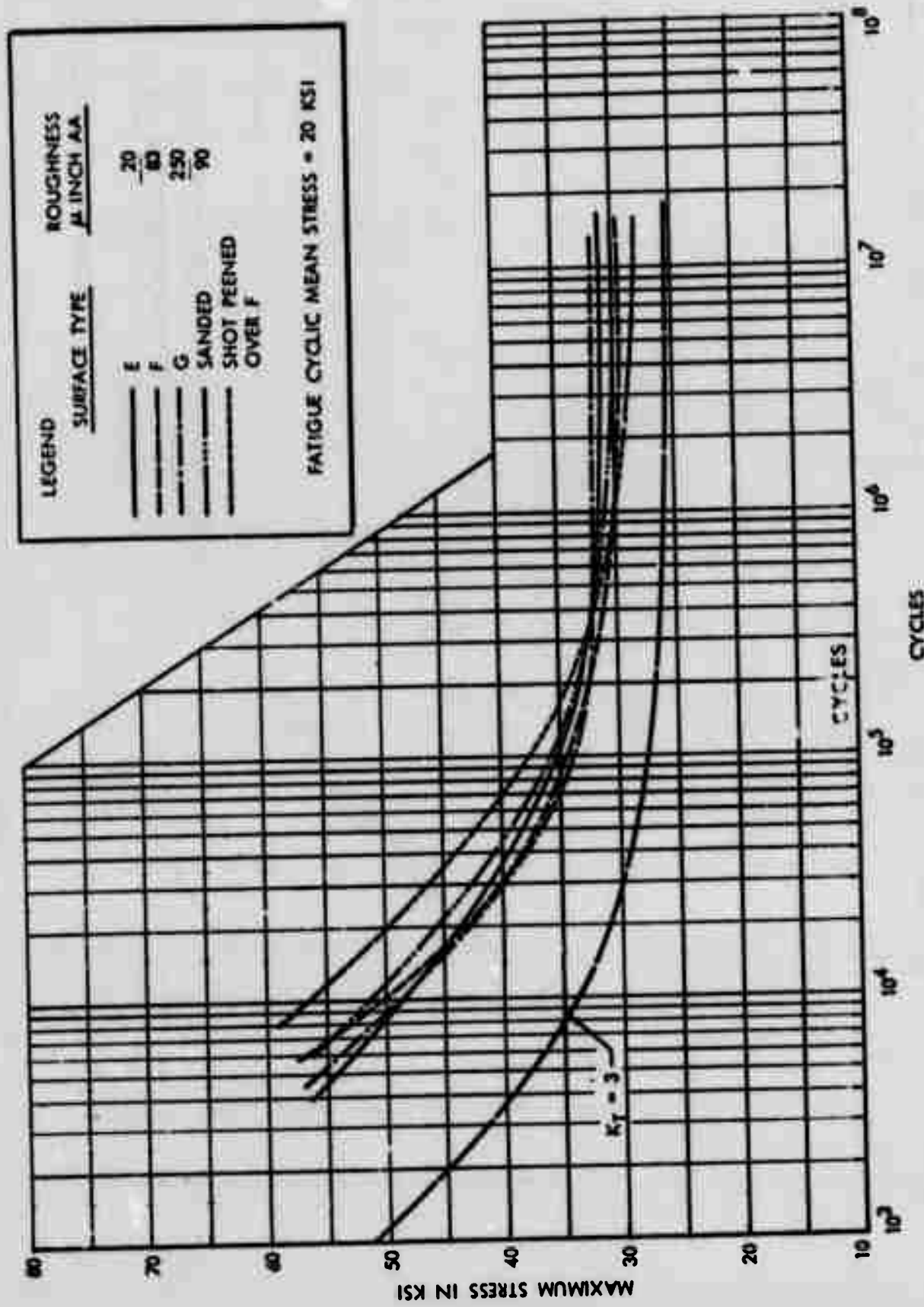

FIGURE I-4 FATIGUE TEST OF 7079-T651 ALUMINUM ALLOY CUT WITH
END OF END MILL AT MEAN STRESS OF 20 KSI

MATERIAL TYPE CUT	ORIENTATION OF LAY TO TEST DIRECTION	SURFACE FINISH IN DIRECTION OF STRESS (μ AA)	FATIGUE STRENGTH, KSI (10 ⁷ CYCLES) ENDURANCE LIMIT
AL 7075-T7351 END MILL-END CUT GENTLE	Parallel	9	23
	Perpendicular	22	19
	Parallel	35	21
	Perpendicular	87	20
END MILL-END CUT ABUSIVE	Parallel	49	20
	Perpendicular	132	22
Ti 6AL-4V ANNEALED END MILL-END CUT GENTLE	Parallel	20	59
	Perpendicular	21	72
	Parallel	52	48
	Perpendicular	100	72
END MILL-END CUT ABUSIVE	Parallel	13	54
	Perpendicular	26	63
	Parallel	25	61
	Perpendicular	56	77

Ref: AFML-TR-74-60 "Surface Integrity of Machined Materials", pp. 146-147.
W.P. Koster, Metcut Research Associates 1974

FIGURE I-5 MILLED SURFACE FINISH VS. FATIGUE STRENGTH CORRELATION

PART I

FOR MACHINED SURFACES OF ALUMINUM PARTS

APPLICATION:

- o PART I OF THIS STANDARD IS APPLICABLE TO ALUMINUM PARTS ONLY.
- o THIS DOCUMENT IS APPLICABLE ONLY WHEN SPECIFICALLY CALLED OUT ON ENGINEERING DRAWINGS.

PURPOSE:

- o THIS DOCUMENT DEFINES THE LIMITS TO WHICH MACHINED SURFACE ROUGHNESS AND MISMATCHES MAY BE PERMITTED IN ORDER TO MINIMIZE HAND FINISHING ON MILLED OR ROUTED PARTS.

GENERAL NOTES:

1. THE MILLING AND ROUTING OF ALUMINUM PARTS SUCH AS BULKHEADS, FITTINGS, LONGERONS, SPARS AND SPAR CAPS PRODUCE TWO KINDS OF SURFACE CONDITIONS:
 - (a) SURFACE WAVINESS OF WIDTH AND HEIGHT IN MAKING CIRCULAR AND ANGULAR MACHINE CUTS.
 - (b) SURFACE MISMATCH IN MACHINING LONGITUDINAL, LATERAL AND VERTICAL SURFACES.
2. THESE SURFACE CONDITIONS SHALL BE IDENTIFIED IN ACCORDANCE WITH THE FOLLOWING TYPES AND SUBJECT TO THE PERMISSIBLE LIMITATIONS AND HAND FINISHING OPERATIONS AS SPECIFIED IN SUBSEQUENT PARAGRAPHS:
 - TYPE I SURFACE ROUGHNESS OF ATTACHING AND MATING SURFACES
 - TYPE II SURFACE WAVINESS AND ROUGHNESS OF NONATTACHING AND NONMATING SURFACES
 - TYPE III SURFACE MISMATCH IN CRITICAL AREAS
 - TYPE IV SURFACE MISMATCH IN NONCRITICAL AREAS
 - TYPE V RADIUS BLENDS AT FLANGE OR STIFFENER INTERSECTIONS
3. ALL SHARP EDGES FOR ALL TYPES REQUIRE DEBURRING, AS SPECIFIED ON THE APPLICABLE DOCUMENT, I.E., FPS-3017 FOR F-16 AND 122001 FOR F-111, EXCEPT FOR FIGURE 1, SECT. F-F.
4. THE TERM "CORNER" IS USED HEREIN TO DESCRIBE THE FILLET AT THE INTERSECTION OF TWO SURFACES CREATED BY THE SIDE OF THE END-MILL. WHERE A THIRD SURFACE INTERSECTS, SUCH AS A W.B., THE TERM "CORNER" IS ALSO USED TO INCLUDE THE SURFACE CREATED BY THE BOTTOM OF THAT END-MILL IN THE AREA OF THAT INTERSECTION.
5. HAND FINISHING SHALL NOT BE PERFORMED FOR "COSMETIC REASONS."
6. ALL METAL REMOVAL OPERATIONS PRIOR TO HAND-FINISHING MUST CLEARLY BE DESIGNED TO PRODUCE AN ACCURATE REPRESENTATION OF THE ENGINEERING DRAWING, I.E., THE RELAXATIONS ALLOWED HEREIN MAY NOT BE ABUSED. SUCH ABUSE IS BASIS FOR REJECTION BY QUALITY ASSURANCE AND CUSTOMER.
7. INSPECTION SHALL BE BASED ON DIMENSIONS ENCOUNTERED AFTER MACHINING AND HAND-FINISHING, PRIOR TO SUBSEQUENT REQUIRED OPERATIONS. ENGINEERING HAS CONSIDERED THE EFFECT OF SUCH OPERATIONS ON DIMENSIONS. CLOSE TOLERANCE AREAS ARE PROTECTED FROM DIMENSIONAL CHANGE BY NDT5-1101.

TYPE I

- o TYPE I SURFACES ARE DEFINED AS SURFACES IN CRITICAL STRESS AREAS OR SURFACES CONTACTING ANY ADJACENT PARTS. TYPE I SURFACES AND PERMISSIBLE SURFACE FINISH LIMITS ARE SHOWN IN FIGURE 1.
- o TYPE I SURFACES SHALL NOT EXCEED 125 MICRO-INCHES AA. ROUGHNESS EXCEEDING THIS AMOUNT SHALL BE HAND FINISHED TO MEET THE REQUIRED FINISH. SEE FIGURE 1.
- o ALL TYPE I SURFACES SHALL BE DESIGNATED ON THE FACE OF THE ENGINEERING DRAWING. SURFACES NOT DESIGNATED AS TYPE I ARE TO BE CONSIDERED AS TYPE II.

DRAWING SHEET STATUS			
SHEET	REV	SHEET	REV
1	J	6	H
2	H	7	G
3	G	8	G
4	H	9	G
5	H	10	G

REVISIONS: (J) (G) (C) (A) (S)
 JULY 1963
 APPROVED

GENERAL DYNAMICS <i>Fort Worth Division</i> FORT WORTH, TEXAS	STANDARD
SURFACE ROUGHNESS AND TOLERANCES FOR MACHINED SURFACES	MOOI
CONTRACT NO AF33(657)-8260	CODE IDENT NO 81755
SHEET 1 OF 10	

FIGURE I-6 SURFACE ROUGHNESS AND TOLERANCES FOR MACHINED SURFACES - STANDARD FOR INSPECTION

TYPE II

- o TYPE II SURFACES ARE DEFINED AS ALL MACHINED EDGES, WEBS, POCKETS, STIFFENERS AND FLANGES THAT ARE NON-ATTACHING SURFACES. TYPE II SURFACES AND PERMISSIBLE SURFACE FINISH LIMITS ARE SHOWN IN FIGURE 1. ENGINEERING MAY CALL FOR TYPE II ON NON-CRITICAL ATTACHMENT SURFACES.
- (H) o TYPE II SURFACES REQUIRE A VISUAL INSPECTION ONLY.
- o HAND FINISHING SHALL NOT BE PERFORMED TO CONTROL THE SURFACE ROUGHNESS REGARDLESS OF THE MACHINE-INDUCED SURFACE CONDITION EXCEPT AS NOTED BELOW.
 - (a) CHATTER MARKS SHALL BE REMOVED BY HAND FINISHING SO AS TO MEET THE 123 MICRO-INCH A-A FINISH SPECIFIED IN FIGURE 1, DETAIL C, SECTION D-D AND DETAIL E.
 - (b) DAMAGE DUE TO CUTTER FAILURE, ENTRAPPED CHIPS OR OTHER DAMAGE, AS DETERMINED BY VISUAL INSPECTION, SHALL BE REWORKED BY HAND FINISHING TO A CONDITION EQUAL TO OR BETTER THAN THE ADJACENT SURFACE ROUGHNESS.
- o SURFACES NOT DESIGNATED AS TYPE I ARE TO BE CONSIDERED TYPE II.

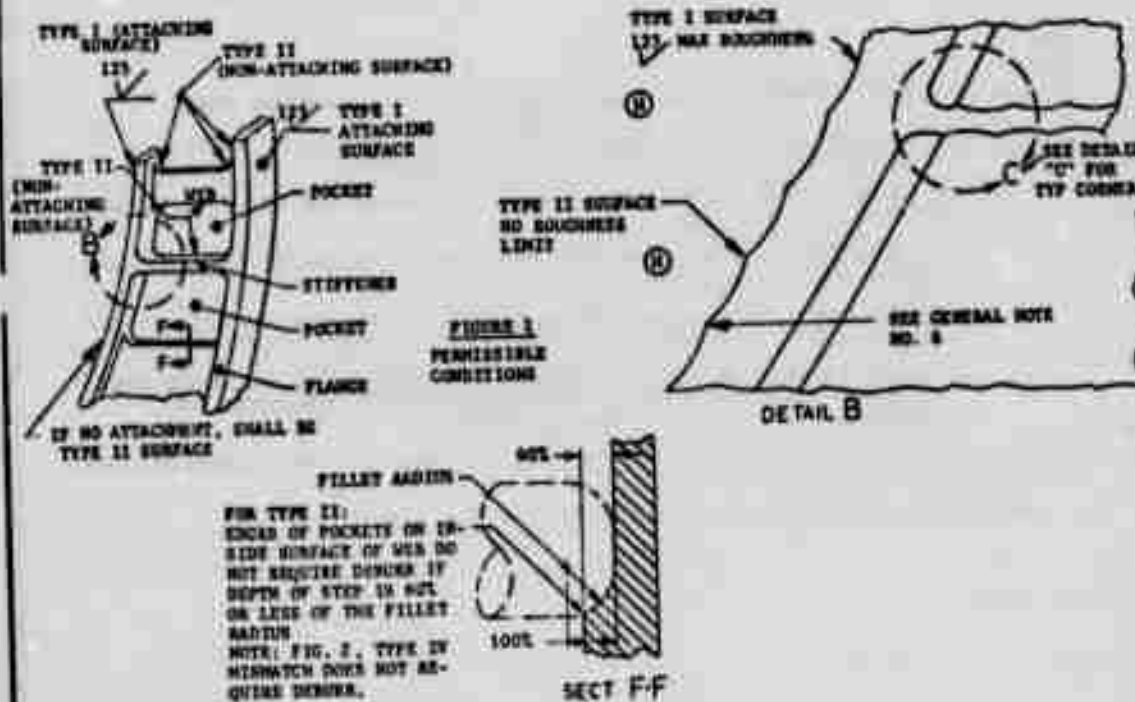

REVISION 6 1 8 DEC 1978
 APPROVED JULY 1943

GENERAL DYNAMICS Fort Worth Division FORT WORTH, TEXAS		STANDARD
SURFACE ROUGHNESS AND TOLERANCES FOR MACHINED SURFACES		MOOI
CONTRACT NO. AF33(616)73-R240	CODE IDENT NO. 81755	SHEET 2

FIGURE I-6 (CONTINUED)

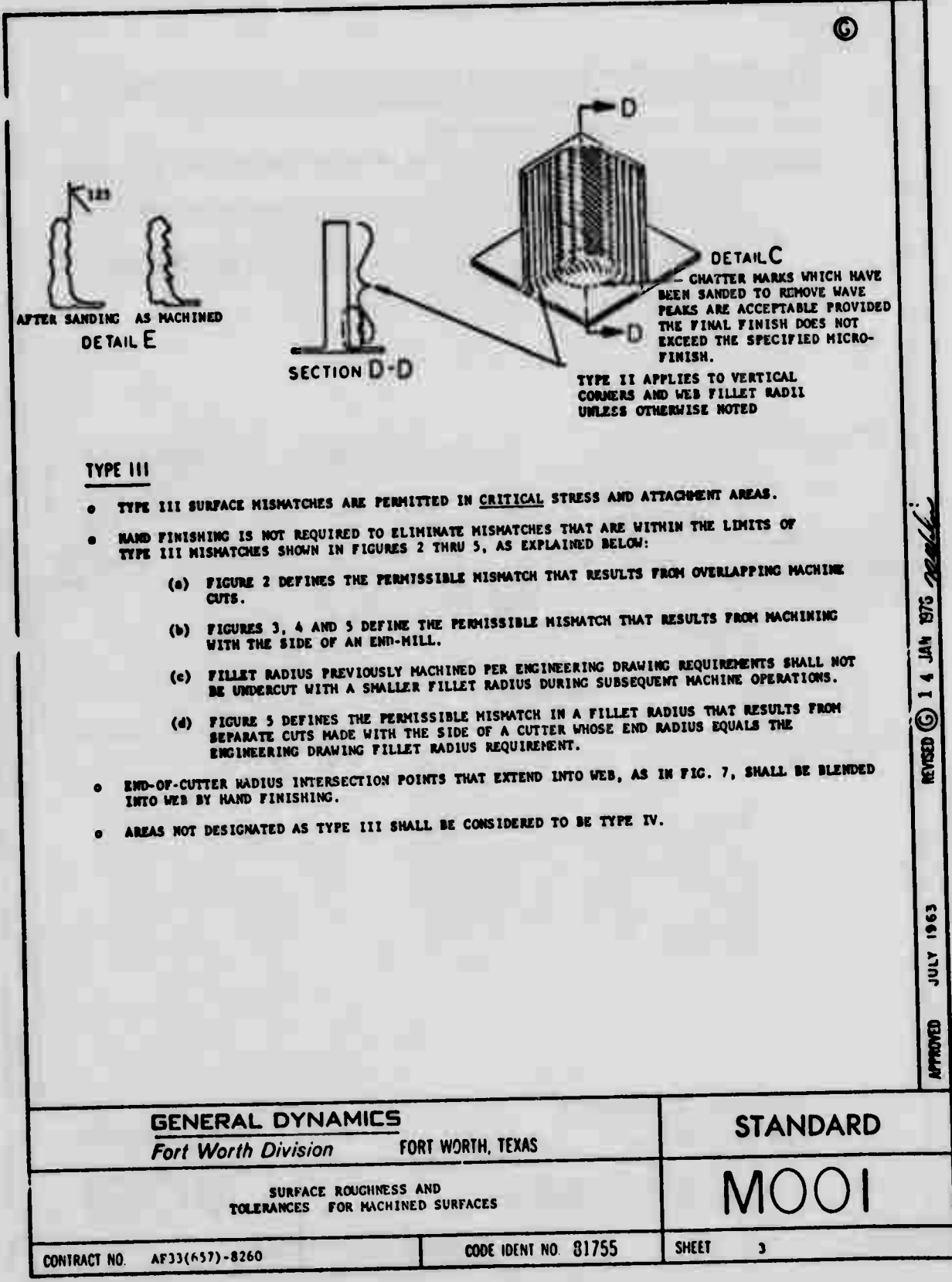

TYPE III

- TYPE III SURFACE MISMATCHES ARE PERMITTED IN CRITICAL STRESS AND ATTACHMENT AREAS.
- HAND FINISHING IS NOT REQUIRED TO ELIMINATE MISMATCHES THAT ARE WITHIN THE LIMITS OF TYPE III MISMATCHES SHOWN IN FIGURES 2 THRU 5, AS EXPLAINED BELOW:
 - (a) FIGURE 2 DEFINES THE PERMISSIBLE MISMATCH THAT RESULTS FROM OVERLAPPING MACHINE CUTS.
 - (b) FIGURES 3, 4 AND 5 DEFINE THE PERMISSIBLE MISMATCH THAT RESULTS FROM MACHINING WITH THE SIDE OF AN END-MILL.
 - (c) FILLET RADIUS PREVIOUSLY MACHINED PER ENGINEERING DRAWING REQUIREMENTS SHALL NOT BE UNDERCUT WITH A SMALLER FILLET RADIUS DURING SUBSEQUENT MACHINE OPERATIONS.
 - (d) FIGURE 5 DEFINES THE PERMISSIBLE MISMATCH IN A FILLET RADIUS THAT RESULTS FROM SEPARATE CUTS MADE WITH THE SIDE OF A CUTTER WHOSE END RADIUS EQUALS THE ENGINEERING DRAWING FILLET RADIUS REQUIREMENT.
- END-OF-CUTTER RADIUS INTERSECTION POINTS THAT EXTEND INTO WEB, AS IN FIG. 7, SHALL BE BLENDED INTO WEB BY HAND FINISHING.
- AREAS NOT DESIGNATED AS TYPE III SHALL BE CONSIDERED TO BE TYPE IV.

GENERAL DYNAMICS Fort Worth Division FORT WORTH, TEXAS		STANDARD
SURFACE ROUGHNESS AND TOLERANCES FOR MACHINED SURFACES		MOOI
CONTRACT NO. AF33(657)-8260	CODE IDENT NO. 81755	SHEET 3

FIGURE I-6 (CONTINUED)

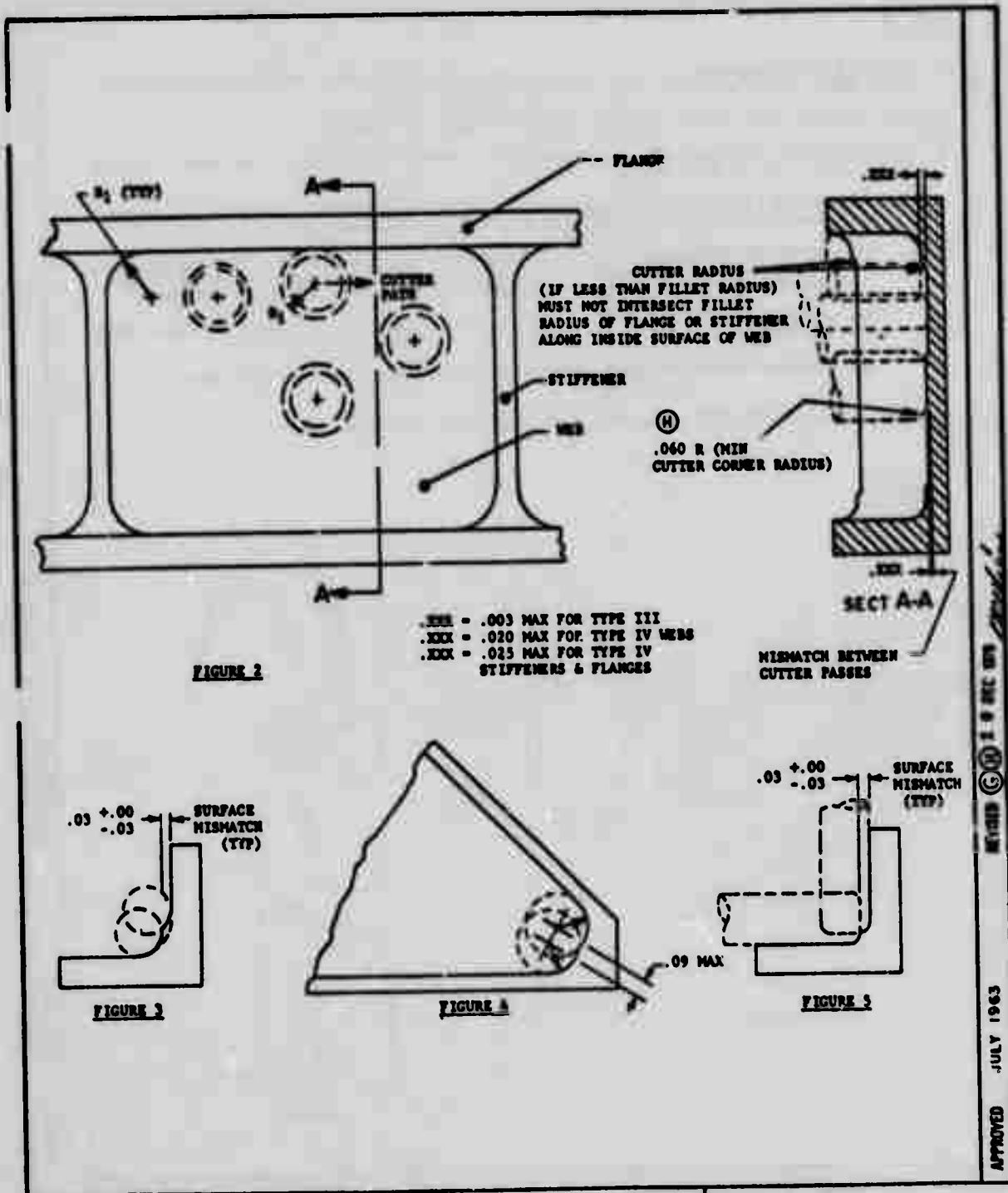

FIGURE I-6 (CONTINUED)

TYPE IV

- TYPE IV SURFACE MISMATCHES ARE PERMITTED IN NON-CRITICAL STRESS AREAS AND NON-ATTACHMENT AREAS ONLY, UNLESS ENGINEERING CALLS FOR TYPE IV IN ATTACHMENT AREAS.
- HAND FINISHING SHALL NOT BE PERFORMED TO ELIMINATE TYPE IV MISMATCHES.
- TYPE IV MISMATCH CONDITIONS AND LIMITS SHALL BE THE SAME AS TYPE III EXCEPT AS SHOWN IN FIGURES 2, 6, 7 AND 8, AND AS EXPLAINED BELOW:
 - (a) FIGURE 2 DEFINES PERMISSIBLE MISMATCH FOR TYPE IV ALONG WEBS, STIFFENERS AND FLANGES PROVIDED THE TOTAL THICKNESS IS WITHIN ENGINEERING DRAWING TOLERANCE.
 - (b) MISMATCHES IN CORNERS THAT EXCEED ENGINEERING DRAWING TOLERANCE ON THE PLUS SIDE SHALL NOT BE HAND FINISHED. MISMATCH IN CORNERS ON THE NEGATIVE SIDE MUST BE WITHIN THE ENGINEERING DRAWING TOLERANCE REQUIREMENTS EXCEPT AS NOTED BELOW AND IN FIGURE 8.
 - (c) CORNER UNDERCUTS BY 0.75"D. OR SMALLER CUTTERS ARE PERMITTED WITHIN THE LIMITS SHOWN IN FIGURE 8.
 - (d) FIGURE 6 DEFINES THE PERMISSIBLE LIMITS FOR BLENDING DIFFERENT FILLET RADII.
- AREAS NOT DESIGNATED AS TYPE III SHALL BE CONSIDERED TO BE TYPE IV.

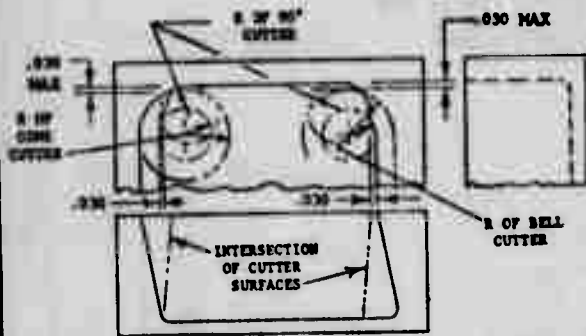

FIGURE 6

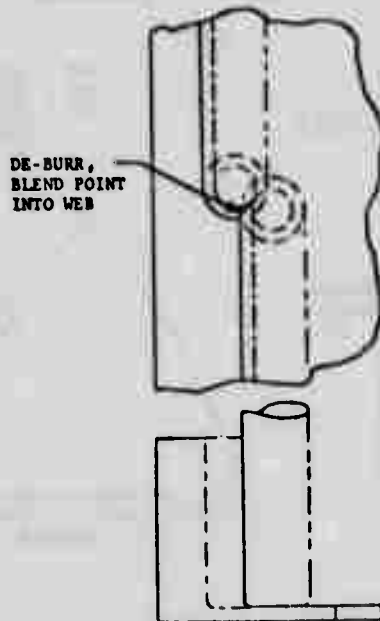

FIGURE 7

APPROVED JULY 1963 REVISED (H) 1 0 DEC 1976

GENERAL DYNAMICS Fort Worth Division FORT WORTH, TEXAS		STANDARD
SURFACE ROUGHNESS AND TOLERANCES FOR MACHINED SURFACES		MOOI
CONTRACT NO. AF33(657)-8260	CODE IDENT NO. 81755	SHEET 5

FIGURE I-6 (CONTINUED)

TOLERANCE OVER LENGTH "D"

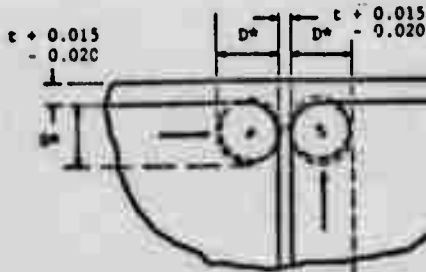

* MAX D = 0.75

FIGURE 8

TYPE V

- TYPE V RADII "BLENDS" ARE SUBJECT TO UNDERCUTTING WHERE FLANGES AND/OR STIFFENERS INTERSECT AT ANGLES OF 60° OR LESS. FIGURE 4 ILLUSTRATES A SURFACE OF UP TO 0.09 INCH MAXIMUM BETWEEN CUTTER CENTERLINES WHICH IS PERMISSIBLE WITHOUT HAND FINISHING. THIS SURFACE TENDS TO ELIMINATE FLANGE/STIFFENER UNDERCUTTING DUE TO CUTTER VIBRATION WHEN THE CUTTER IS DWELLING.

ENGINEERING REFERENCE:

- EXAMPLE OF CALLOUT

- (H) IN THE GENERAL NOTES, SPECIFY ONE OR BOTH OF NOTES 1 OR 2, OR NOTE 3, AS APPLICABLE:
 - ✓ DENOTES SURFACES PER MOO1, TYPE I & MISMATCH PER MOO1, TYPE III. ALL OTHER SURFACES PER MOO1 TYPE II & MISMATCH PER MOO1, TYPE IV.
 - RADII BLENDS SHALL BE PER MOO1, TYPE V.
 - ALL SURFACES PER MOO1 TYPE II AND MISMATCH PER MOO1 TYPE IV.

- NOTE TO DESIGNERS

- (H) ALL MOO1, TYPE I SURFACES & MOO1 TYPE III MISMATCHES AS WELL AS MOO1 TYPE V RADII BLENDS MUST BE SPECIFIED ON THE FACE OF THE DRAWING BY THE SYMBOL ✓ OR BY ACTUAL CALLOUT (MOO1, TYPE I, ETC.) ON THE REQUIRED SURFACE. NOTE 3 REQUIRES CALLOUT IN NOTES ONLY.

TOLERANCES:

THIS SECTION APPLIES TO F-111 DRAWINGS ONLY FOR VARIATIONS IN THICKNESS TOLERANCES WHEN THE ENGINEERING DRAWING SPECIFIES THAT MACHINED SURFACES ARE TO BE IN ACCORDANCE WITH MOO1, TYPE I AND/OR TYPE II.

VARIATIONS IN THE THICKNESS TOLERANCES FOR WEBS, FLANGES, STIFFENERS, ETC. AS SHOWN IN FIGURE 9 WILL APPLY WHEN THREE PLACE DIMENSIONS (.XXX) WITH NO TOLERANCE, OTHER THAN THAT SPECIFIED IN THE GENERAL TOLERANCE BLOCK, ARE SHOWN ON THE FACE OF THE DRAWING.

REVISED (G) 1 0 DEC 1973
APPROVED JULY 1963

GENERAL DYNAMICS Fort Worth Division FORT WORTH, TEXAS		STANDARD
SURFACE ROUGHNESS AND TOLERANCES FOR MACHINED SURFACES		MOO1
CONTRACT NO AF33(657)-8260	CODE IDENT NO. 81755	SHEET 6

FIGURE I-6 (CONTINUED)

6

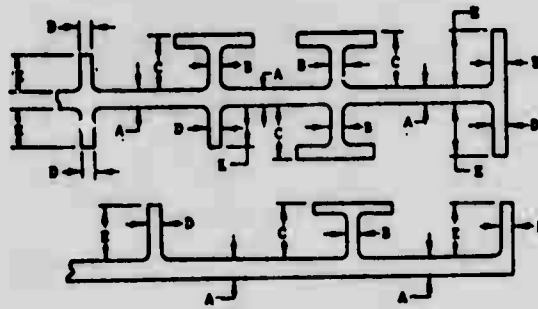

TOLERANCE ON *A* FOR WEBS FROM 0.040 TO 0.059 MAY BE ±0.015 PROVIDED THE AREA OF THE POCKET IN EXCESS OF THE TOLERANCE OF ±0.010 IS NOT GREATER THAN 25% OF THAT POCKET AREA.

FOR C > 1.00 & UP TO 2.00 INCL
 TOL ON B = ±0.020
 FOR E > 0.80 & UP TO 2.00 INCL
 TOL ON D = ±0.020

FIGURE 9

APPROVED JULY 1963 REVISED © 14 JAN 1976

GENERAL DYNAMICS <i>Fort Worth Division</i> FORT WORTH, TEXAS		STANDARD
SURFACE ROUGHNESS AND TOLERANCES FOR MACHINED SURFACES		MOOI
CONTRACT NO. AF33(657)-8260	CODE ICENT NO. 81755	SHEET 7

FIGURE I-6 (CONTINUED)

A P P E N D I X J
STIFFENER MACHINING TEST DATA

APPENDIX J
TABLE OF CONTENTS

	<u>Page</u>
1.0 TEST RATIONAL AND APPROACH	258
2.0 OBTAINMENT AND TREATMENT OF DATA	259
2.1 Aluminum Specimens	259
2.2 Titanium Specimens	260
3.0 SURFACE EFFECTS ANALYSIS	260
3.1 Background	260
3.2 Objective	261
3.3 Procedure and Results	261
3.4 Conclusions	262

APPENDIX J

LIST OF ILLUSTRATIONS

<u>Figure</u>		<u>Page</u>
J-1	Stiffener Machining Test on Bohle Vertical Mill	263
J-2	Stiffener Test Specimen No. 51, 1½ Inch Diameter	264
J-3	Stiffener Machining Test Specimens - Aluminum	265
J-4	Stiffener Machining Test - Matrix of Test Numbers (Aluminum)	266
J-5	Stiffener Machining Tests - Aluminum - Data Plot	267
J-6	Feed Rate Limit for 2.0 In. Diameter Cutter, Aluminum	272
J-7	Feed Rate Limit for 1.5 In. Diameter Cutter, Aluminum	273
J-8	Feed Rate Limit for 1.0 In. Diameter Cutter, Aluminum	274
J-9	Feed Rate Limit for ¾ In. Diameter Cutter, Aluminum	275
J-10	Feed Rate Limit for ½ In. Diameter Cutter, Aluminum	276
J-11	Stiffener Machining Tests - Matrix of Test Numbers (Titanium)	277
J-12	Specimen 16A, Ti-6Al-4V Beta Annealed, 0.05" Radial Depth of Cut, 3½" Per Minute Feed Rate	278
J-13	Specimen 18C, Ti-6Al-4V Beta Annealed, 1" Radial Depth of Cut, 15½" Per Minute Feed Rate	278

APPENDIX J

LIST OF ILLUSTRATIONS (Cont'd)

<u>Figure</u>		<u>Page</u>
J-14	Specimen 2A, 2124 Al-T851, 1" Radial Depth of Cut, 10" Per Minute Feed Rate	279
J-15	Specimen 2D, 2124 Al-T851, 1" Radial Depth of Cut, 70" Per Minute Feed Rate	279

APPENDIX J
LIST OF TABLES

<u>Table</u>		<u>Page</u>
J-I	Comparison of Recommended vs. Test Feed Rates Per Tooth - Peripheral Milling in Aluminum	280
J-II	Machining Test Results - Stiffeners - Aluminum	281
J-III	Aluminum Stiffener Data Analysis	285
J-IV	Machining Test Results - Stiffeners - Titanium 6AL-4V b.a.	289
J-V	Machining Parameters for Surface Effect Analysis	290

APPENDIX J

STIFFENER MACHINING TESTS

The purpose of the stiffener machining test program was to explore the potential for increasing metal removal rates on aluminum and titanium by combining rough and finish milling radial cuts. Despite apparent success in showing achievable higher metal removal rates, the combined rough/finish machining approach described below was abandoned during the NC testing of Appendix K in favor of the conventional, separate rough and finish machining. The stiffener tests did not adequately represent the realities of NC operation. The sacrifice in this decision was small, as can be seen in Appendix K.

1.0 TEST RATIONAL AND APPROACH

If conventional machining roughness requirements are relaxed or eliminated and if design proportions of pockets, i.e., web width/thickness ratios, are controlled, stiffeners and flanges become the critical machining elements due to the cantilever flexibility of the end-mill and of the stiffener.

The potential source of cost savings was considered to be in the finish machining which constitutes roughly 50% or more of the machine time for removal of 1-2% of the material. By using the rough cutter full size (limited size reduction due to re-sharpening) and making a substantial radial cut during the finish machining, the total machining time could be substantially reduced.

The question that the stiffener tests tried to answer was would such programming and machining produce dimensionally acceptable parts, and, if so, at what metal removal rates? The answer to this question was obtained from data resulting from machining of 1.0 and 1.5 inch high stiffeners (or flanges) of .100 inch nominal thickness out of 2124-T851 aluminum alloy and 6Al-4V beta annealed titanium. Feed rates were increased up to 70 inches per minute in aluminum and up to 15½ inches per minute in titanium.

2.0 OBTAINMENT AND TREATMENT OF DATA

Dimensional accuracy and surface roughness data was obtained from 51 aluminum and 8 titanium stiffener specimens by varying the following machining parameters:

- a. Diameter of Cutter
- b. Length of axial cut
- c. Length of radial cut
- d. Cutter rotational speed
- e. Cutter feed rate

Results and analysis of the stiffener machining tests are presented in the following paragraphs.

2.1 Aluminum Specimens

Each specimen consisted of four stiffeners, with each stiffener being machined at a different feed rate. Figures J-1 thru J-3 show typical specimens in various stages of progress. Figure J-4 depicts a matrix of all aluminum test specimens related to depth of cut, radial cut, and cutter diameter. This figure provides a quick cross-reference for finding the various machining parameters and combinations thereof that this program involved. The information of Table J-I compares the feed rates (per tooth) for different diameter cutters as used in the stiffener test with the values recommended by industry standards for machining aluminum.

Numerical results of the aluminum machining tests, thickness dimensions and surface roughness, are organized and presented in Table J-II. Radial cut, cutter diameter, flute length, number of flutes, axial cut, feed rate and location of measurement are all listed for each test. Figure J-5 is a graphical representation of the thickness measurements of the aluminum tests in the form of nominal dimension deviations versus feed rates. Each plot provides a quantitative visual indication of machining accuracy for a particular set of machining conditions.

The information of Table J-III is a rearrangement of that presented in Table J-II but includes a calculation of metal removal rate and a qualitative ranking of dimensional accuracy of stiffener thicknesses. The acceptability of the thickness measurements at each feed rate for every test is rated as: acceptable, minor rework required, finish cut required, or unacceptable. The rankings of Table J-III are assembled (for each cutter size) graphically on feed rate limit charts, Figures J-6 thru J-10. The five figures provide maximum finish machining

feed rates for any given area of cut (up to 1.0 square inch) concurrent with dimensional tolerances of +0.015, -0.010 inches. (Area of cut is defined as the radial cut dimension multiplied by the axial cut dimension.) The dashed line on each figure defines the recommended safe rough machining metal removal rate derived in the NC programmed development phase. Flute length was limited to 2.00 inches (except for the 1.50 inch diameter cutter with 2.25 inch flute length).

2.2 Titanium Specimens

The titanium specimens are similar to the aluminum specimens, but consist of only three stiffeners. Like the aluminum specimens, each stiffener was machined at a different feed rate. Figure J-11 presents a matrix of all titanium specimens related to depth of cut, radial cut, and cutter diameter.

Numerical results of the titanium machining tests, thickness dimensions and surface roughness, are organized and presented in Table J-IV. No analysis of dimensional quality nor development of recommended maximum finish machine rates were accomplished for the titanium tests, as the majority of effort was concentrated on machining of aluminum.

3.0 SURFACE EFFECTS ANALYSIS

Dramatic increases in machining rates raised questions as to effects on finish surface quality and the capability of the current in-house etch process to remove all "smeared" material in preparation for penetrant inspection. To answer such questions, the following study was performed.

3.1 Background

The Military specification (MIL-I-6866B) governing the penetrant inspection process requires that soft metals, previously machined, be etched prior to inspection. This requirement was incorporated into General Dynamics Non-Destructive Test Standard (NDTS) 1101, Penetrant Inspection, dated 27 June 1975. The basis for this requirement is to remove the smeared metal on the surface of machined parts so that cracks or other defects will not be obscured to the inspection process.

At the time of writing NDTs 1101, no data was available on the depth of etch necessary; however, on the basis of other specifications and reports in the aerospace industry, a value of 0.0005" from each surface was used.

3.2 Objective

The objective of this analysis was to measure the depth of smeared metal on aluminum and titanium machined (milled) surfaces and to determine the effect of abusive machining practices on the smeared layer.

3.3 Procedure and Results

Two titanium and two aluminum machined (milled) stiffener specimens were obtained for this investigation. The machining parameters which were used on these specimens are shown in Table J-V.

As a check for possible overheating caused by machining at the high feed rates, conductivity was measured on the aluminum specimens. No difference in conductivity, as compared to the base metal, was found in stiffeners machined at various feed rates.

Each stiffener was sectioned for microexamination. For both the aluminum and titanium specimens, no change in general microstructure was found associated with the different machining parameters. The depth of smeared metal layer on each stiffener was measured by use of a measuring eyepiece on the metallograph; this depth is shown in Table J-V for each condition. Figures J-12 through J-15 show representative microstructures of both materials.

With both the aluminum and titanium specimens, it is seen that the depth of smeared metal increases with severity of machining practice. Only with the most severe conditions would the 0.0005" etch, as required by NDTs 1101, be insufficient to remove the smeared metal layer. The two higher feed rates, 7½ and 15½ in/min., used on the titanium material produced unacceptable surface finishes and thus would not be suitable for production machining. In fact, the high feed rate used on specimen 18C caused the cutter to seize to the material and break; it is interesting to note that no gross metallurgical damage accompanied this severity of machining.

3.4 Conclusions

From the limited data generated in this work, it appears that the etch depth specified in NDTs 1101 is sufficient to remove smeared metal.

Additional work is necessary to study other methods of machining, drilling, reaming, deburring, and abrasive blasting operations. Other alloys of aluminum and titanium must also be studied. In addition, the actual effect of smeared metal on crack detection should be ascertained in future work.

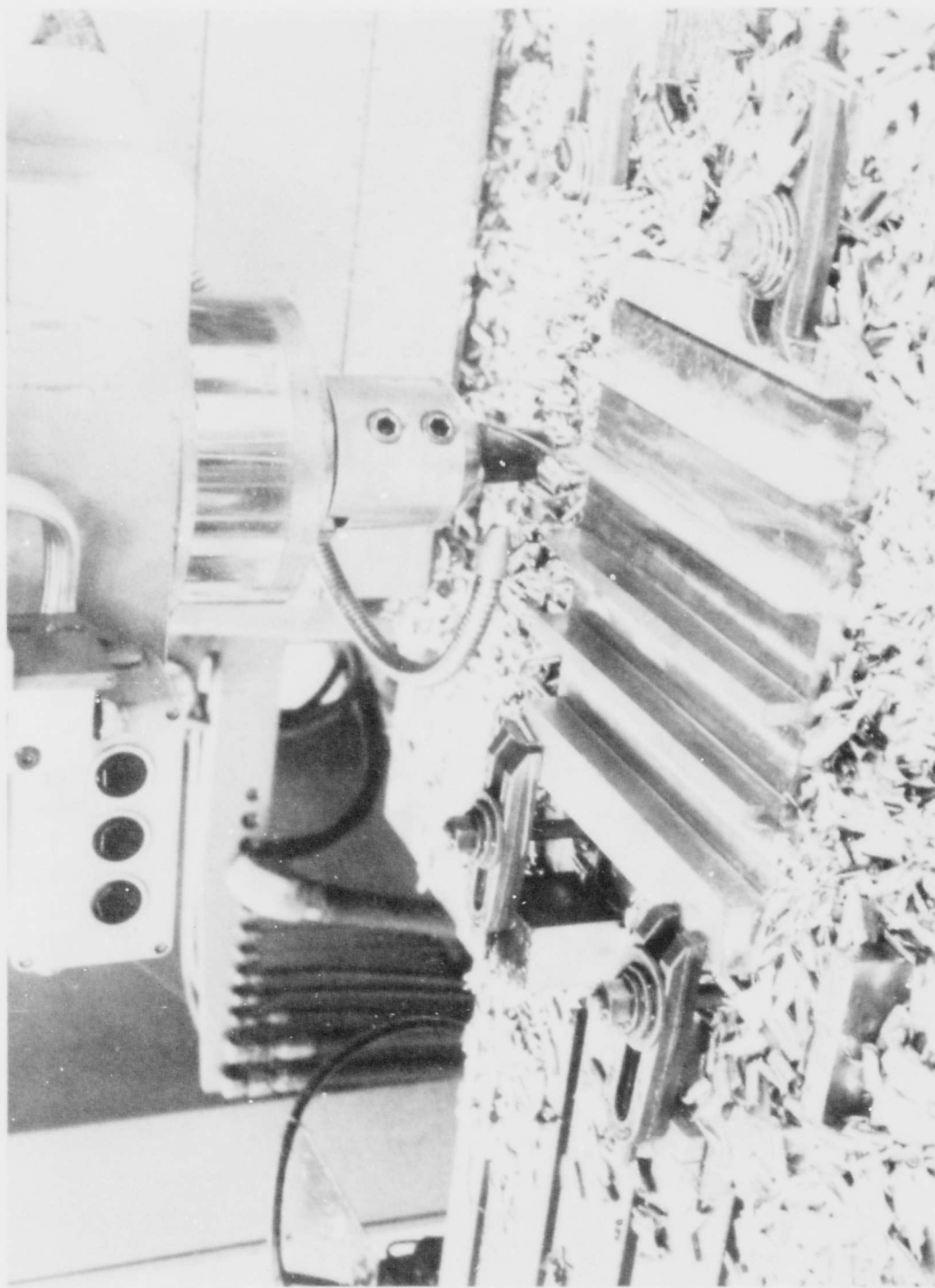

FIGURE J-1 STIFFENER MACHINING TEST ON BOHLE VERTICAL MILL



FIGURE J-2 STIFFENER TEST SPECIMEN NO. 51, 1½ INCH DIAMETER CUTTER - ALUMINUM

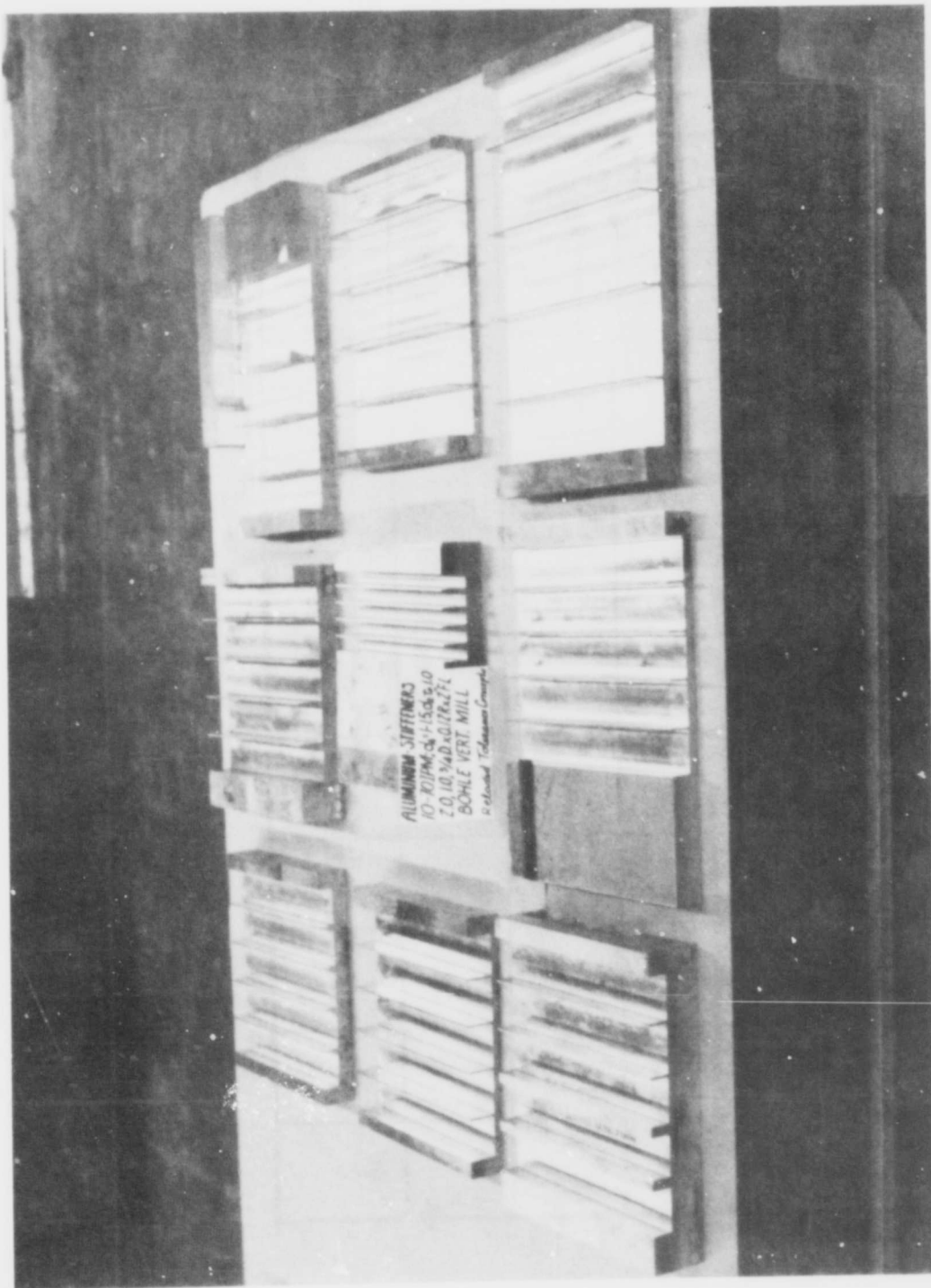
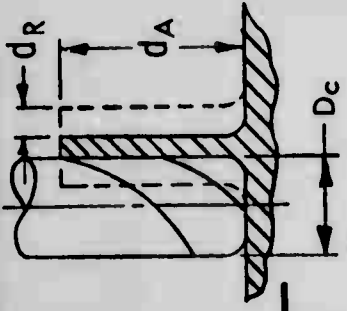

FIGURE J-3 STIFFENER MACHINING TEST SPECIMENS - ALUMINUM

Dc	dA	dr											
		.05	.125	.20	.25	.375	.50	.75	1.00				
.50	1.0	31	32		33								
	1.5	34	35		36								
.75	1.0	14	37		25	38							
	1.5	15	39		40	41							
1.00	1.0	42			26	43				44			
	1.5	45			46,62	47				48			
1.50	1.0	49			50					51		52	
	1.5	53			54,60,61*					55,63		56	
2.00	1.0	5,6								8		57	9
	1.5	4,10		3,11								58	2,13



* "Conventional" cutter rotation, all others are "climb cuts".

FIGURE J-4 STIFFENER MACHINING TEST - MATRIX OF TEST NUMBERS (ALUMINUM)

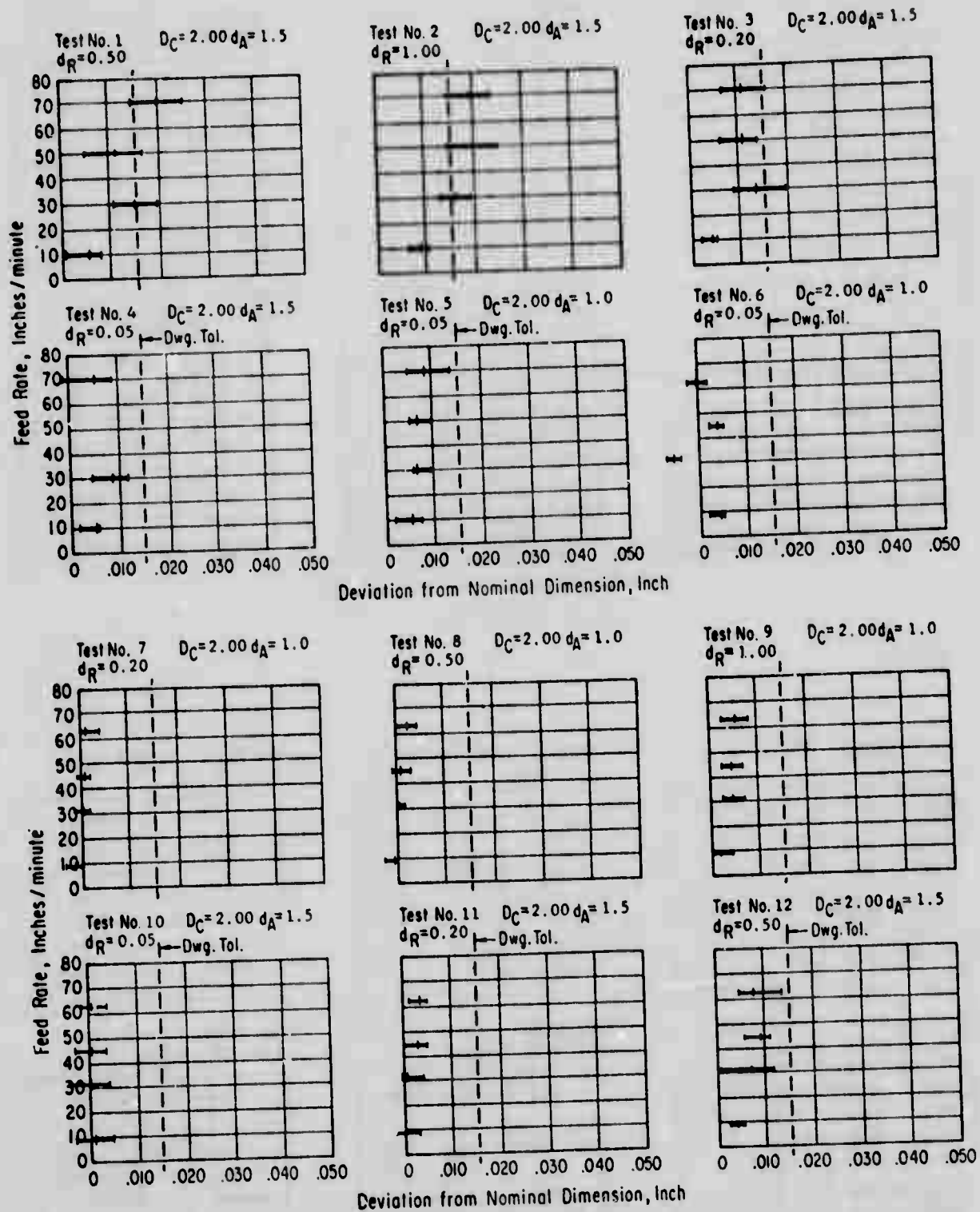

- NOTES:
1. FLUTE LENGTH = 2.0
 2. MATERIAL 2124-T351
 3. d_A = AXIAL CUT (STIFFENER HEIGHT)
 4. d_R = RADIAL CUT
 5. D_C = CUTTER DIAMETER

FIGURE J-5 STIFFENER MACHINING TESTS - ALUMINUM - DATA PLOT

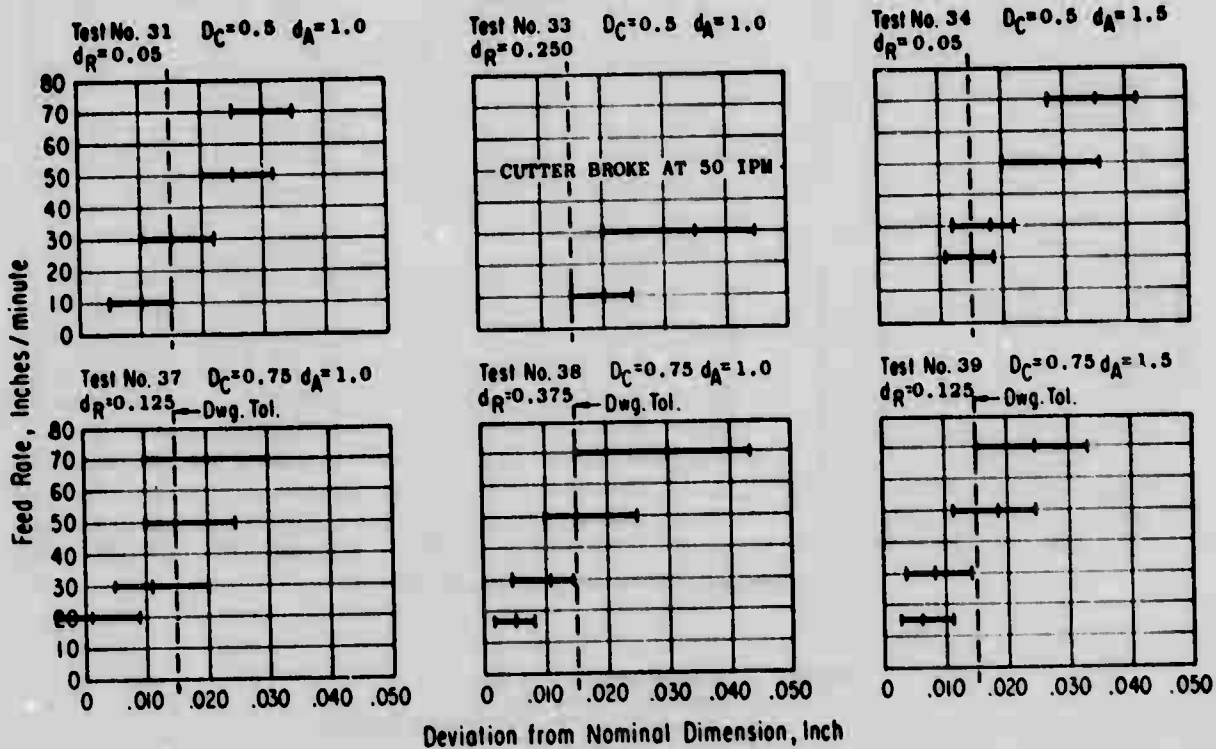
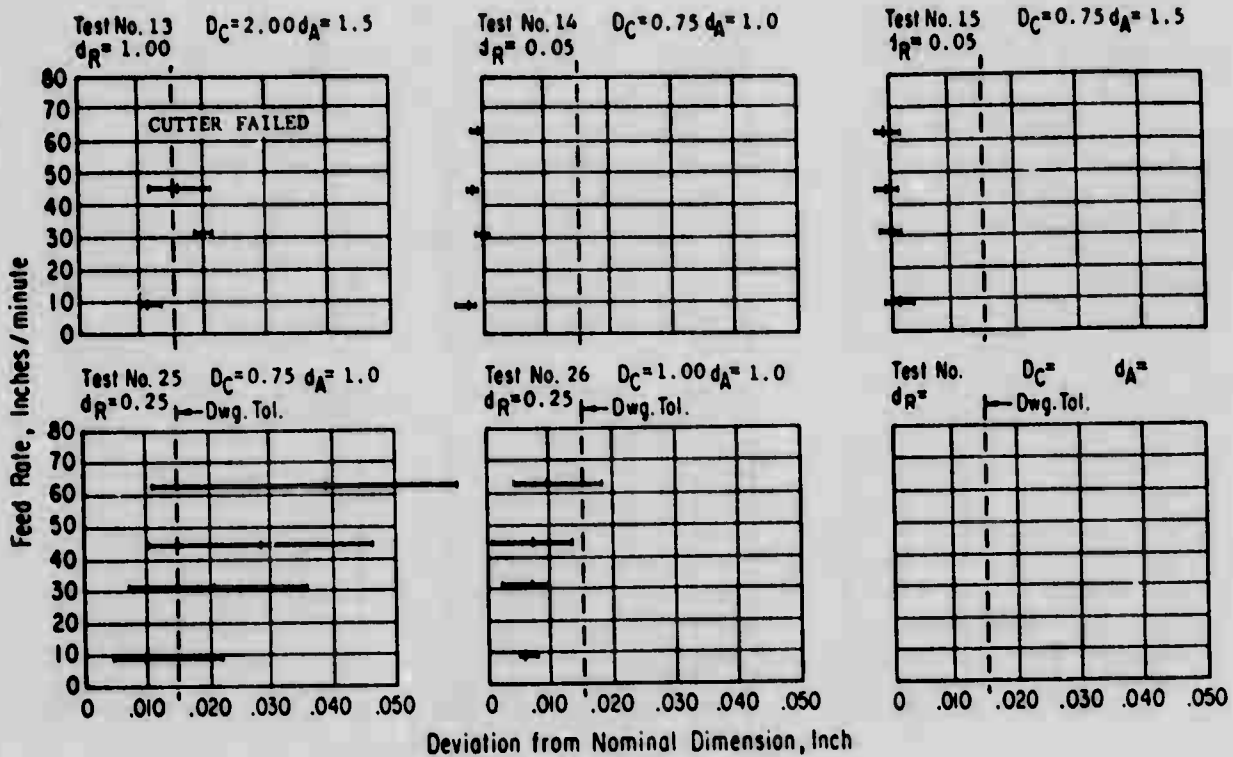

FIGURE J-5 (Cont'd)

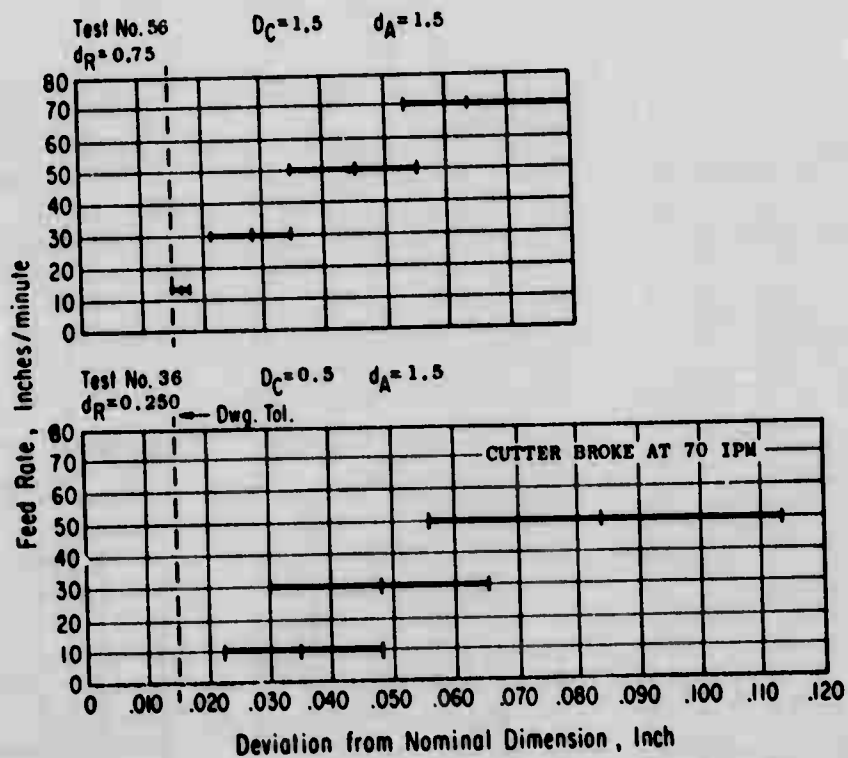
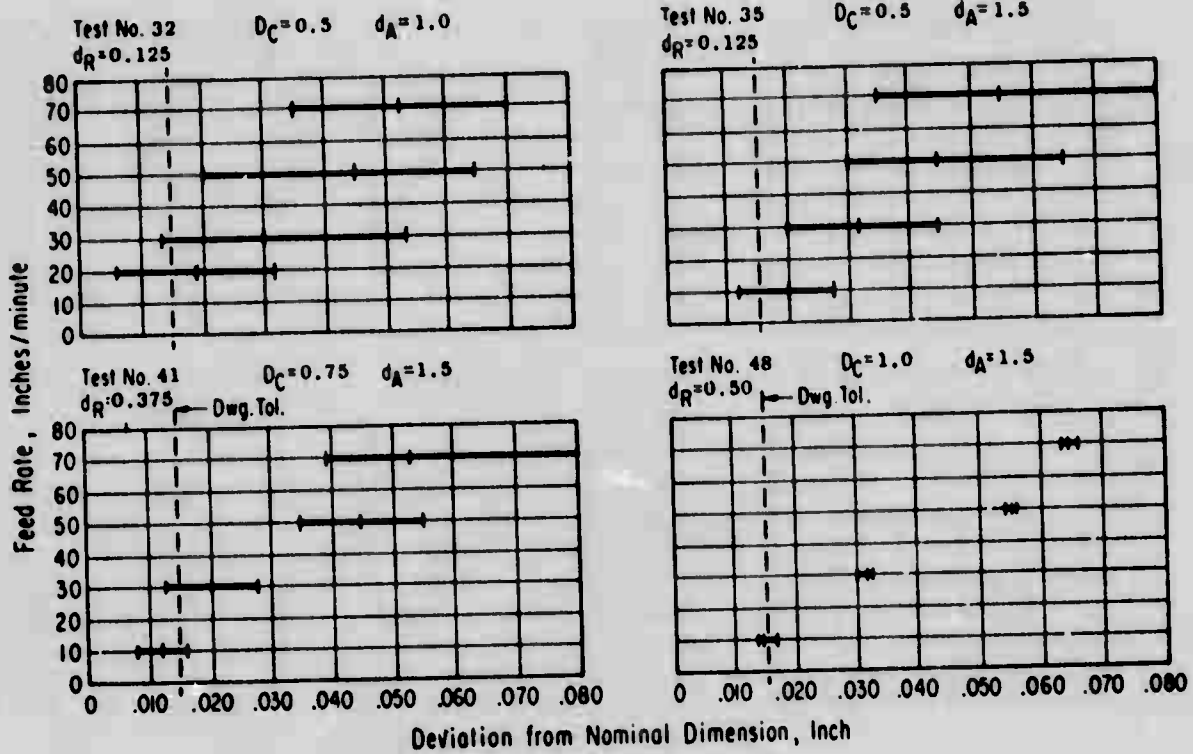

FIGURE J-5 (Cont'd)

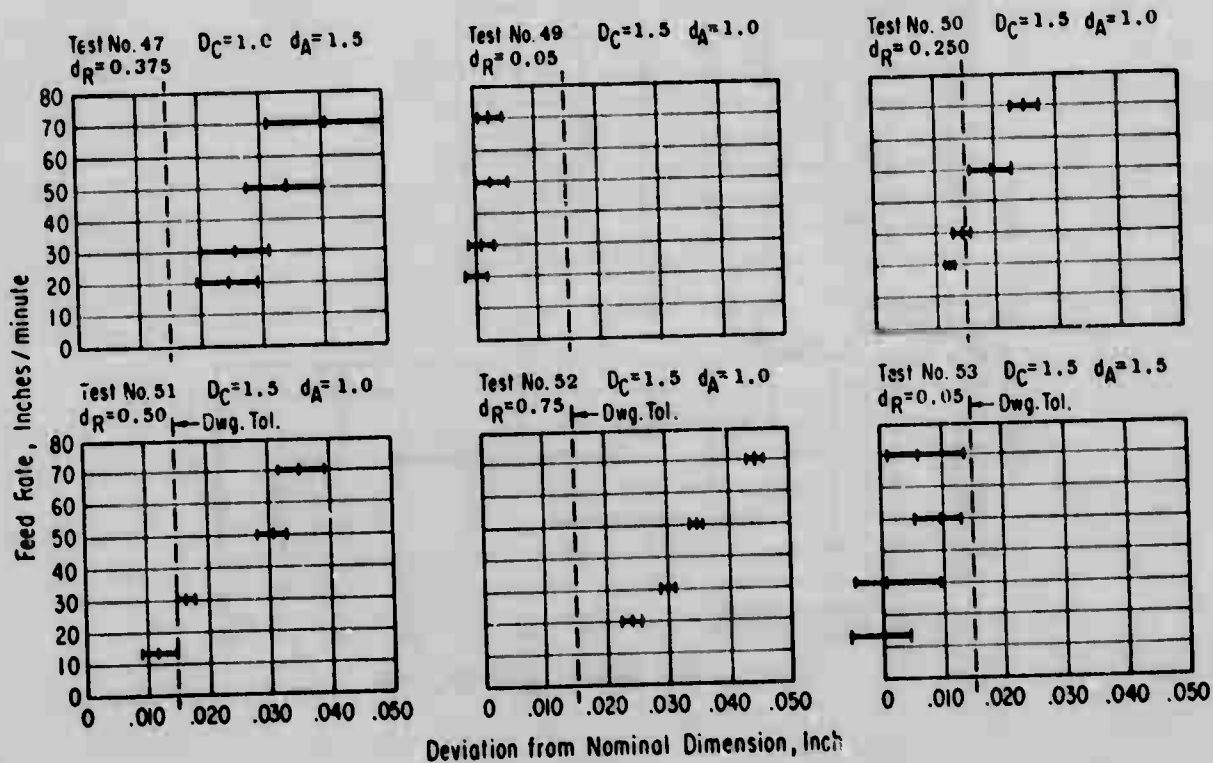
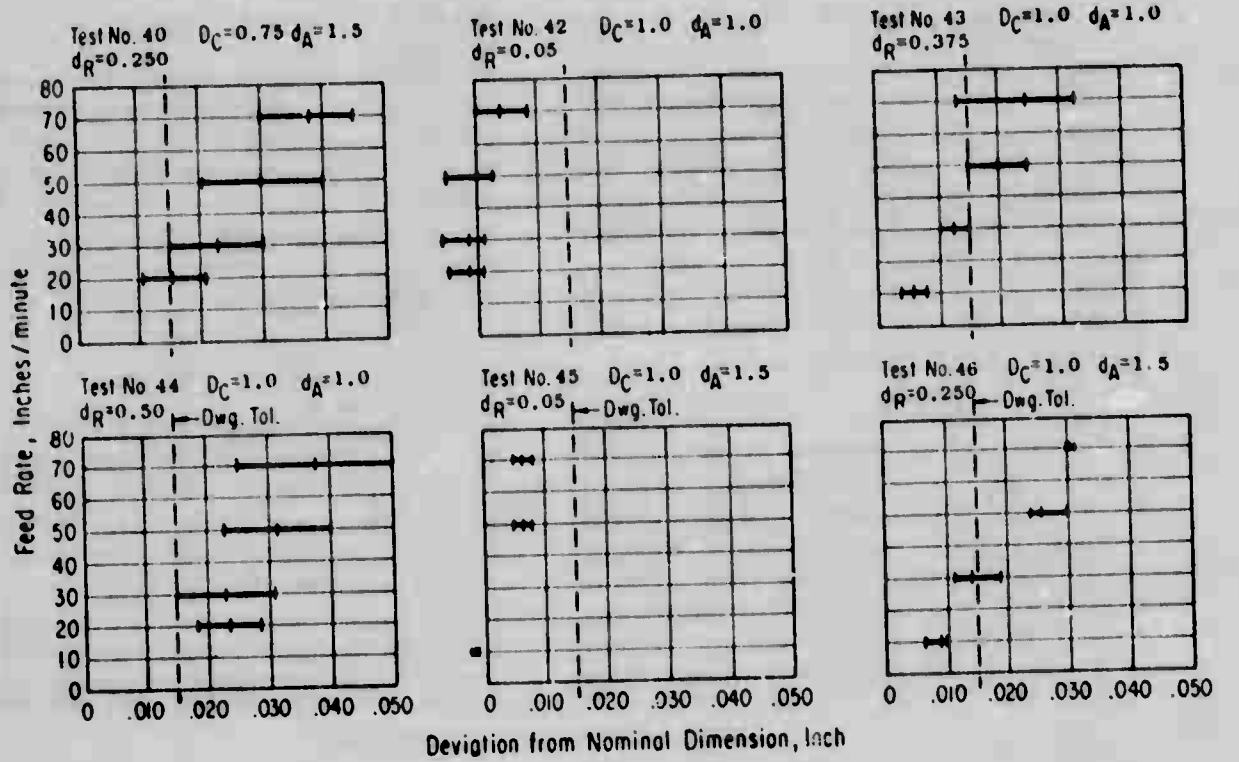

FIGURE J-5 (Cont'd)

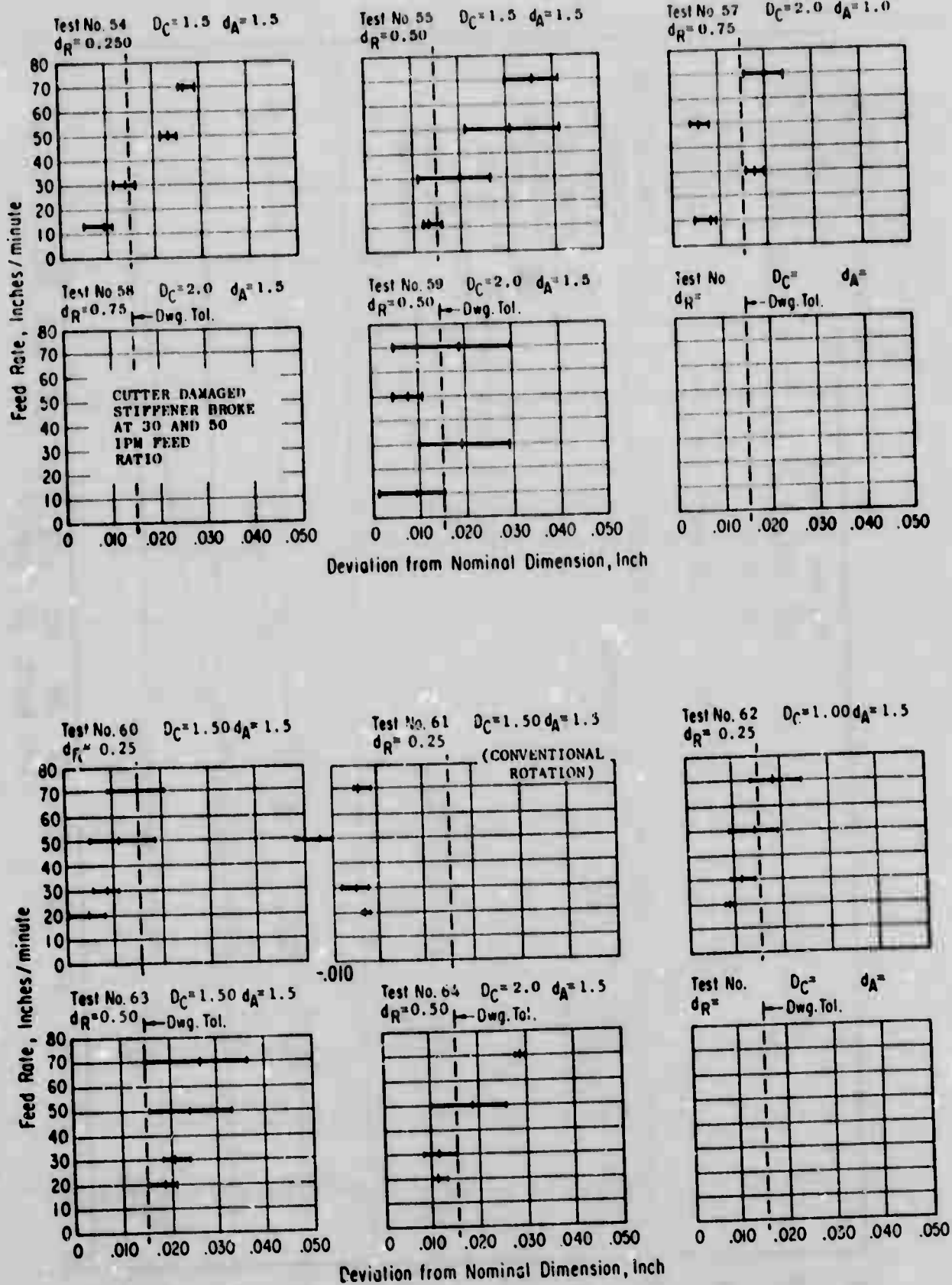

FIGURE J-5 (Cont'd)

Dc = 2.0 IN.

F.L. = 2.0 IN.

TOLERANCE: +.015/-0.00

TEST NO. 1-4, 10-13;

57, 59 (1400 RPM)

RPM: 1500 AND AS NOTED

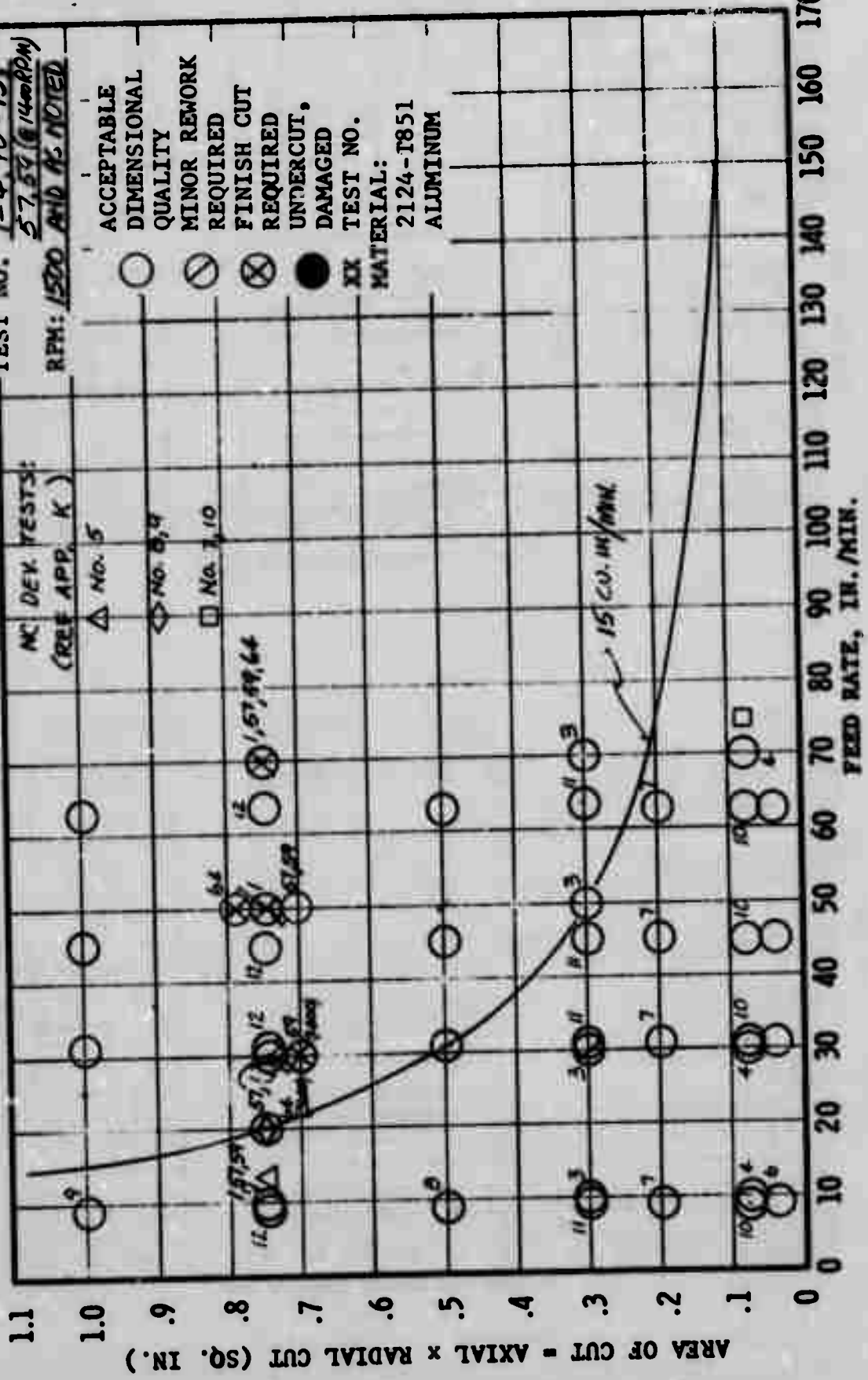

FIGURE J-6 FEED RATE LIMIT FOR 2.0 INCH DIAMETER CUTTER, ALUMINUM

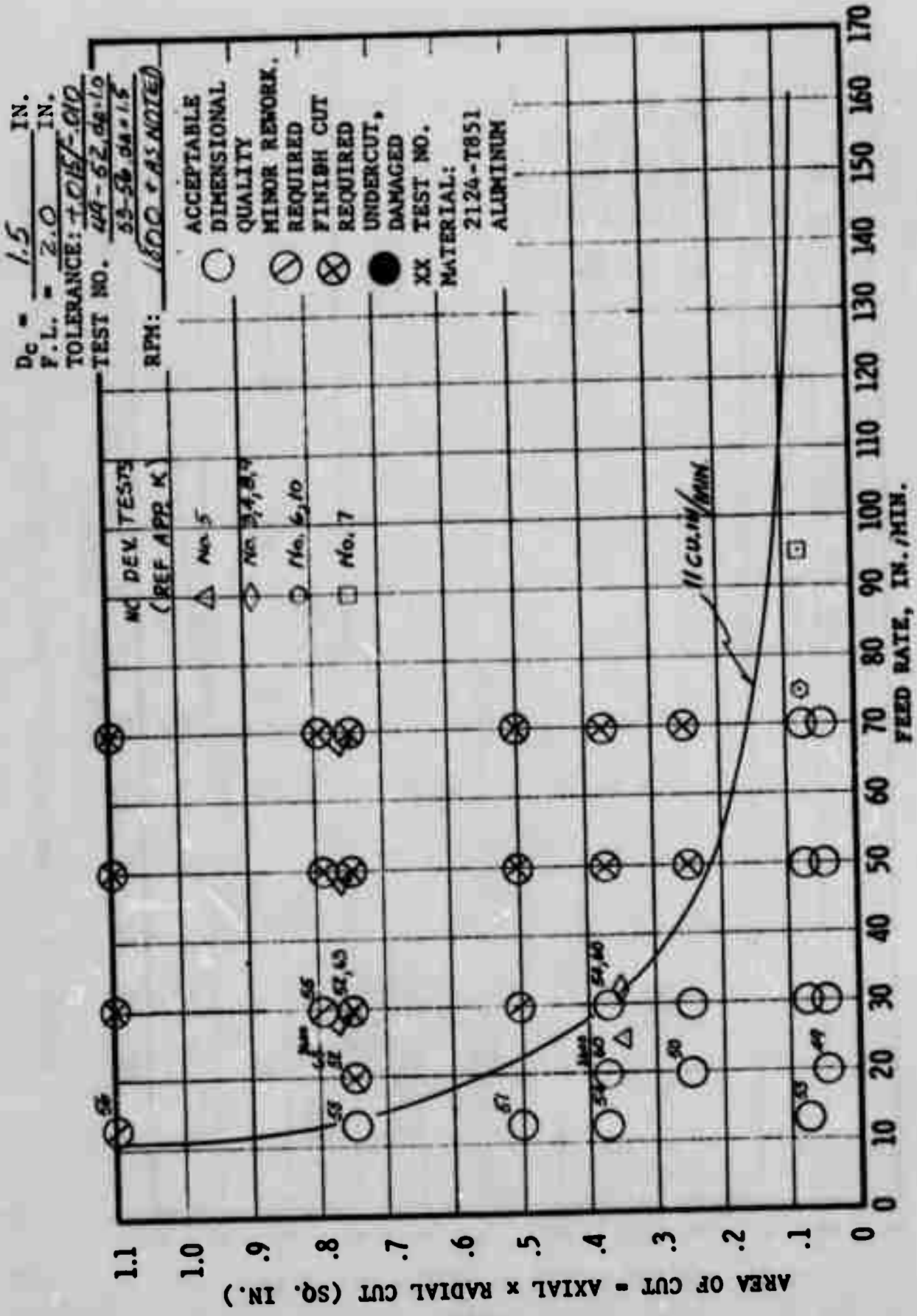

FIGURE J-7 FEED RATE LIMIT FOR 1.5 INCH DIAMETER CUTTER, ALUMINUM

$D_c = 1.0$ IN.
 $F.L. = 2.0$ IN.
 TOLERANCE: ± 0.015 IN.
 TEST NO. 42-44, 26, 49, 10
 45-48 $d_4 = 1.5$
 RPM: 2560 + 63 NOTED

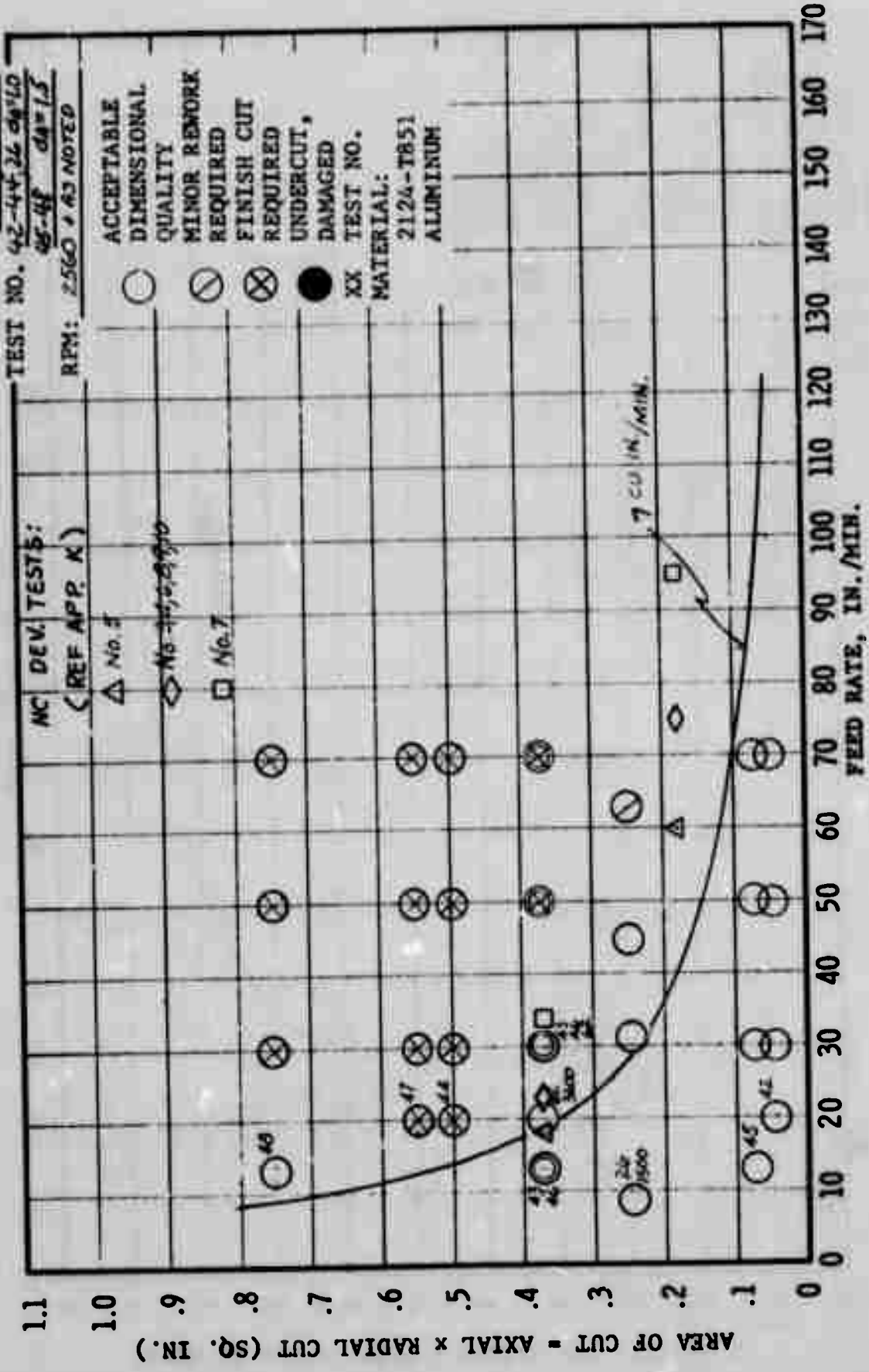

FIGURE J-8 FEED RATE LIMIT FOR 1.0 INCH DIAMETER CUTTER, ALUMINUM

$D_c = 0.75$ IN.

F.L. = $\frac{2.0}{\quad}$ IN.

TOLERANCE:

TEST NO. 14 15 25 @ 1500

37-4 @ 3600

RPM: A=1500, B=3600

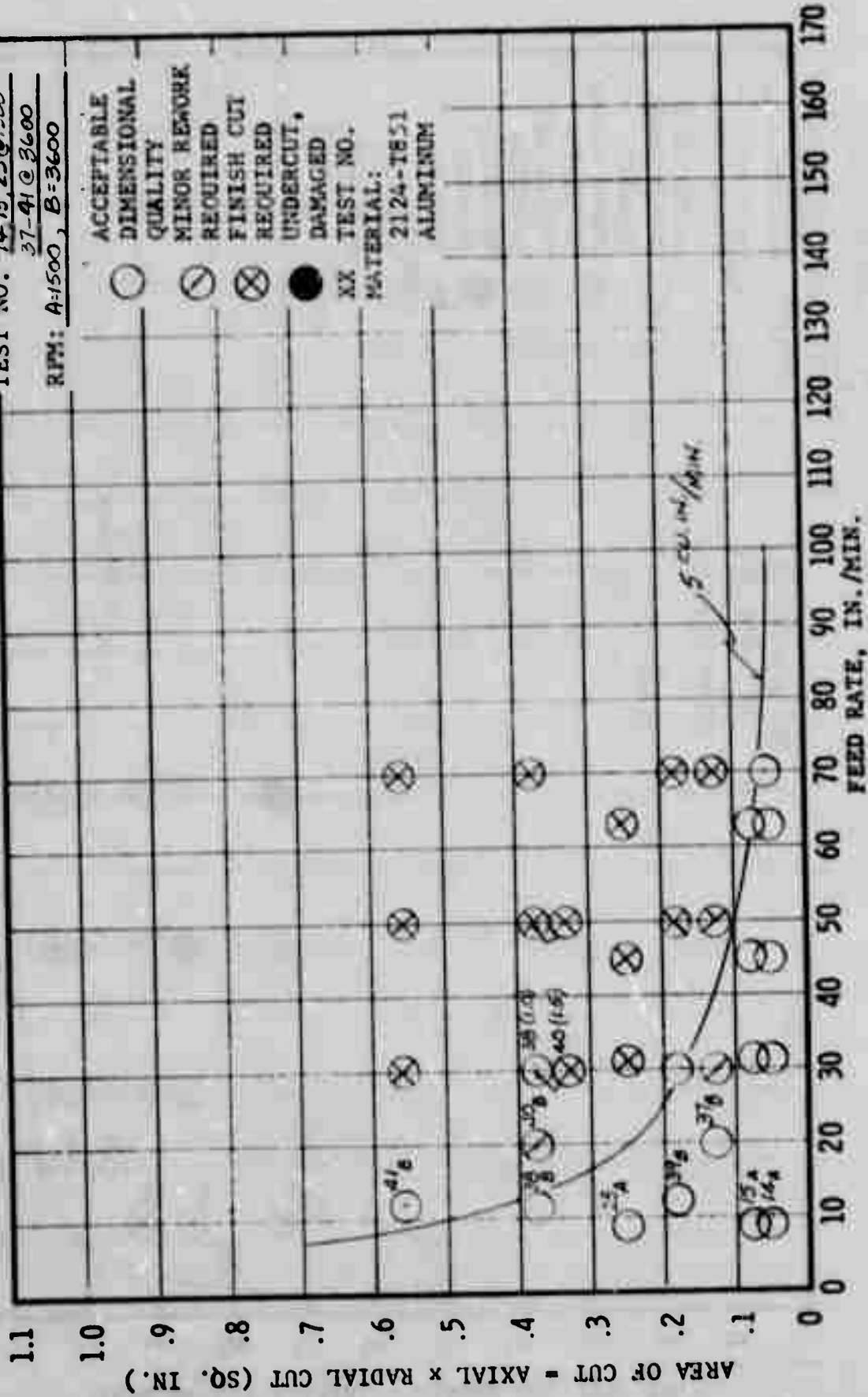

FIGURE J-9 FEED RATE LIMIT FOR 3/4 INCH DIAMETER CUTTER, ALUMINUM

$D_c = \frac{0.50}{\text{IN.}}$
 $F.L. = \frac{2.0}{\text{IN.}}$
 TOLERANCE: ± 0.015
 TEST NO. 31-36

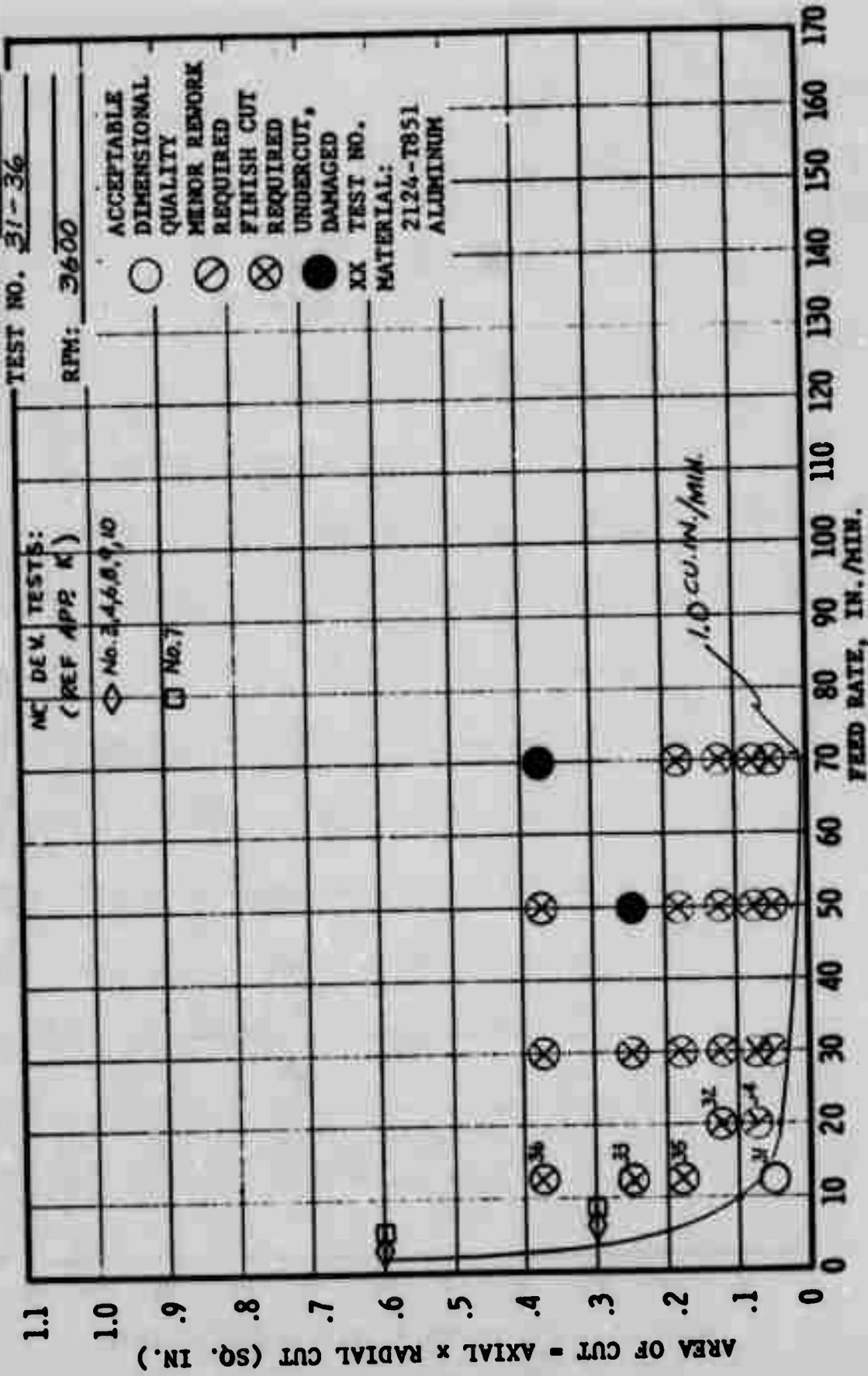

FIGURE J-10 FEED RATE LIMIT FOR 1/2 INCH DIAMETER CUTTER, ALUMINUM

D _c	d _A	d _R			
		.05	.25	.50	1.00
.75	1.0	22			
	1.5	23			
2.00	1.0	16,19		17	18
	1.5		21	20	

FIGURE J-11 STIFFENER MACHINING TESTS - MATRIX OF TEST NUMBERS (TITANIUM)

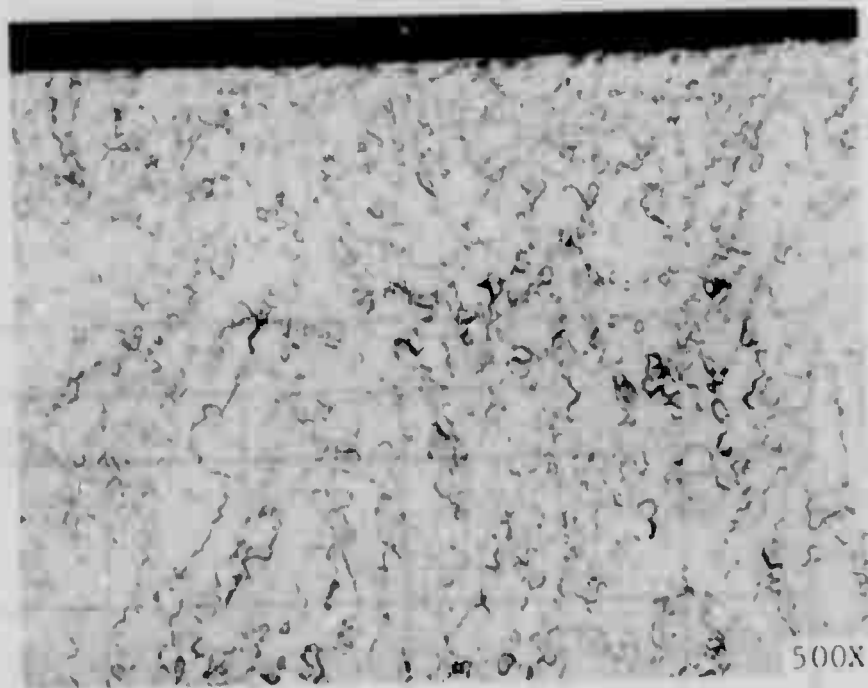

FIGURE J-12 SPECIMEN 16A, Ti-6Al-4V BETA ANNEALED,
0.05" RADIAL DEPTH OF CUT,
3 1/4" PER MINUTE FEED RATE

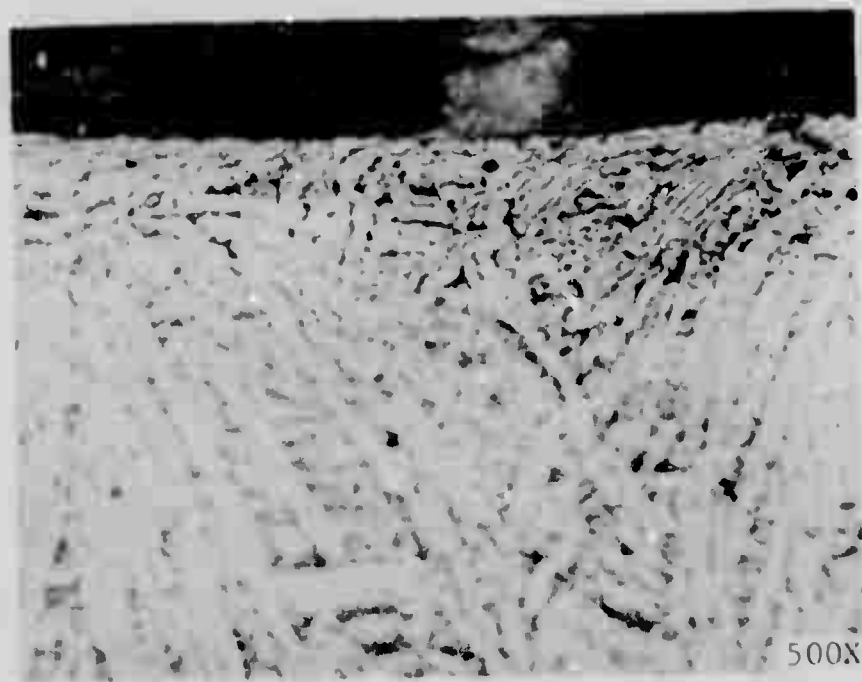

FIGURE J-13 SPECIMEN 18C, Ti-6Al-4V BETA ANNEALED,
1" RADIAL DEPTH OF CUT,
15 1/4" PER MINUTE FEED RATE

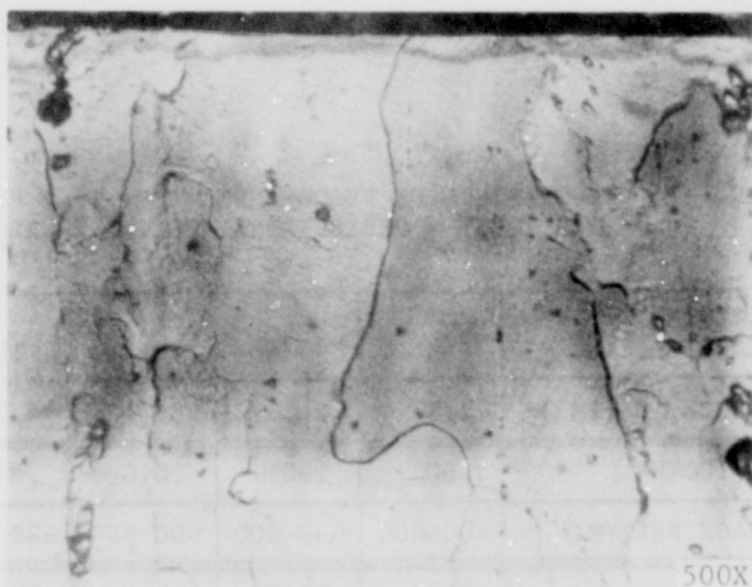

FIGURE J-14 SPECIMEN 2A, 2124-T851,
1" RADIAL DEPTH OF CUT,
10" PER MINUTE FEED RATE



FIGURE J-15 SPECIMEN 2D, 2124-T851,
1" RADIAL DEPTH OF CUT,
70" PER MINUTE FEED RATE

TABLE J-1 COMPARISON OF RECOMMENDED* VS. TEST FEED RATES
PER TOOTH - PERIPHERIAL MILLING IN ALUMINUM

H.S.S. 2 FLUTE CUTTER DIAMETER, IN.	$\frac{1}{2}$	$\frac{3}{4}$	1	$1\frac{1}{2}$	2
CIRCUMFERENCE, C (IN.)	1.57	2.36	3.14	4.71	6.28
REC. FEED/TOOTH*	.005	.008	.010	.010	.010
REC. SURFACE FEET/MIN.*	600-800	600-800	600-800	600-800	600-800
TEST RPM	3600	1500 3600	1500 2560 3600	1800 3600	1500 3600
TEST FEED/TOOTH @ 10 IN./MIN. (10/2xRPM)	.0014	.0033 .0014	.0033 .0020 .0014	.0028 .0014	.0033 .0014
TEST FEED/TOOTH @ 70 IN./MIN. (70/2xRPM)	.010	.023 .010	.023 .014 .010	.019 .010	.023 .010
TEST SURFACE FEET/MIN. (RPMxC/12)	471	295 708	393 670 942	707 1413	785 1884

* Reference Machining Data Handbook, p. 179 2nd Ed.,
"Wrought Aluminum Alloys Solution Treated and Aged"

TABLE J-II MACHINING TEST RESULTS--STIFFENERS--ALUMINUM

1500 RPM CUTTER 2.00 D x 0.12 R x 2.00 F.L. H.S.S. (2 Flutes)														
Test No.	Radial Cut	Top/ Bot.	Measured thickness and surface AA - in											
			Feed			Feed			Feed			Feed		
da = 1.50			10 IPM			30 IPM			50 IPM			70 IPM		
1	0.30	T	0.101	0.104	0.104	0.111	0.112	0.114	0.105	0.107	0.108	0.114	0.114	0.118
		B	0.103	0.107	0.108	0.117	0.118	0.119	0.117	0.117	0.118	0.128	0.128	0.125
		AA		24									21	
2	1.00	T	0.107	0.108	0.109	0.114	0.113	0.113	0.114	0.115	0.116	0.114	0.115	--
		B	0.110	0.109	0.111	0.119	0.119	0.119	0.125	0.125	0.121	0.121	0.124	--
		AA		24									30	
3	0.30	T	0.103	0.102	0.102	0.108	0.108	0.109	0.108	0.107	0.110	0.107	0.109	0.108
		B	0.104	0.105	0.105	0.116	0.116	0.119	0.117	0.113	0.113	0.112	0.115	0.116
		AA		23									25	
4	0.05	T	0.105	0.104	0.104	0.111	0.110	0.112	0.090	0.092	0.092	0.109	0.108	0.108
		B	0.102	0.103	0.107	0.105	0.105	0.104	0.050	0.048	0.050	0.101	0.101	0.099
		AA		10									20	
da = 1.00														
5	0.05	T	0.105	0.105	0.102	0.106	0.105	0.105	0.109	0.106	0.104	0.106	0.105	0.105
		B	0.107	0.107	0.105	0.109	0.109	0.108	0.110	0.108	0.109	0.113	0.111	0.109
		AA		11									17	
da = 1.50			9 IPM			31 IPM			45 IPM			63 IPM		
6	0.05	T	0.105	0.105	0.105	0.093	0.093	0.093	0.106	0.106	0.103	0.102	0.101	0.102
		B	0.102	0.102	0.102	0.092	0.092	0.092	0.103	0.103	0.103	0.098	0.098	0.098
		AA		22									24	
7	0.30	T	0.098	0.097	0.097	0.098	0.098	0.098	0.100	0.100	0.099	0.100	0.100	0.100
		B	0.100	0.100	0.100	0.103	0.101	0.101	0.102	0.102	0.102	0.104	0.104	0.104
		AA		21									31	
8	0.50	T	0.098	0.097	0.097	0.100	0.100	0.100	0.100	0.099	0.099	0.100	0.100	0.100
		B	0.100	0.100	0.100	0.102	0.103	0.102	0.103	0.103	0.103	0.103	0.103	0.103
		AA		27									25	
9	1.00	T	0.100	0.100	0.102	0.102	0.102	0.103	0.102	0.102	0.103	0.103	0.104	0.105
		B	0.103	0.103	0.103	0.106	0.107	0.106	0.107	0.107	0.107	0.108	0.107	0.106
		AA		17									27	
da = 1.50			9 IPM			31 IPM			45 IPM			63 IPM		
10	0.05	T	0.104	0.104	0.105	0.104	0.103	0.103	0.104	0.104	0.104	0.104	0.104	0.104
		B	0.098	0.097	0.097	0.096	0.097	0.097	0.098	0.098	0.097	0.098	0.098	0.098
		AA		20									23	
11	0.20	T	0.100	0.099	0.098	0.100	0.100	0.100	0.101	0.101	0.100	0.102	0.101	0.101
		B	0.103	0.101	0.101	0.103	0.102	0.103	0.105	0.105	0.105	0.104	0.104	0.103
		AA		28									26	
12	0.50	T	0.103	0.103	0.103	0.101	0.102	0.102	0.105	0.106	0.107	0.104	0.105	0.104
		B	0.106	0.106	0.106	0.111	0.112	0.112	0.111	0.112	0.110	0.112	0.110	0.113
		AA		25									30	
13	1.00	T	0.110	0.110	0.110	0.118	0.118	0.119	0.112	0.114	0.114			
		B	0.112	0.113	0.113	0.122	0.122	0.120	0.118	0.118	0.122			
		AA		21										CUTTER FAILED
da = 1.00			Cutter 0.75 D x 0.12 R x 2.00 F.L. H.S.S.											
14	0.05	T	0.098	0.098	0.097	0.101	0.100	0.100	0.098	0.098	0.097	0.098	0.097	0.097
		B	0.095	0.096	0.095	0.100	0.098	0.098	0.098	0.098	0.098	0.100	0.100	0.100
		AA		81									87	
da = 1.50														
15	0.05	T	0.104	0.104	0.104	0.102	0.102	0.102	0.102	0.102	0.102	0.102	0.102	0.102
		B	0.100	0.099	0.099	0.098	0.098	0.098	0.097	0.097	0.096	0.099	0.098	0.097
		AA		40									44	
da = 1.00														
25	0.25	T	0.104	0.104	0.104	0.107	0.107	0.107	0.110	0.110	0.110	0.113	0.113	0.112
		B	0.117	0.116	0.116	0.125	0.125	0.125	0.144	0.146	0.148	0.182	0.182	0.182
		AA		58 44V									100H 88V	184 45V
da = 1.00			Cutter 1.00 D x 0.125 R x 2.00 F.L. H.S.S. (2 Flutes)											
26	0.25	T	0.104	0.104	0.105	0.103	0.102	0.102	0.101	0.101	0.101	0.104	0.104	0.104
		B	0.106	0.106	0.107	0.116	0.116	0.110	0.112	0.112	0.112	0.117	0.113	0.118
		AA		45									27	

- da = Stiffener Height
- L = Measurement one inch left of center of stiffener span
- C = Measurement at stiffener center of span
- R = Measurement one inch right of center of stiffener span
- T = Measurement near top of stiffener
- B = Measurement near bottom of stiffener

TABLE J-II (CONTINUED)

3600 RPM CUTTER 0.5 D x 0.12 R x 2.00 F.L. H.S.S. (2 Flutes) (3,4)														
Measured Thickness and Surface AA - μ In. (1) (6)														
Test No.	Radial Cut	Top/Bottom	Feed			Feed			Feed			Feed		
			L	C _L	K	L	C _L	K	L	C _L	K	L	C _L	K
$d_A = 1.0$			13 IPM (2A)			30 IPM			50 IPM			70 IPM		
31	.05	T	0.106	0.106	0.106	0.111	0.112	0.112	0.121	0.119	0.122	0.124	0.125	0.128
		B	0.113	0.112	0.114	0.122	0.121	0.114	0.129	0.129	0.131	0.134	0.135	0.135
		AA	106			217			322			225		
$d_A = 1.0$			20 IPM (2B)											
32	.125	T	0.107	0.107	0.107	0.114	0.114	0.117	0.122	0.123	0.123	0.137	0.138	0.138
		B	0.130	0.131	0.132	0.141	0.153	0.153	0.164	0.165	0.164	0.169	0.168	0.166
		AA	210			431			396			470		
$d_A = 1.0$			13 IPM (2A)											
33	.25	T	0.118	0.117	0.116	0.122	0.123	0.123	BROKE CUTTER					
		B	0.124	0.125	0.126	0.146	0.146	0.146						
		AA	277			423								
$d_A = 1.5$			20 IPM (2B)											
34	.05	T	0.112	0.114	0.116	0.112	0.113	0.115	0.122	0.120	0.125	0.127	0.129	0.130
		B	0.119	0.117	0.117	0.122	0.122	0.122	0.135	0.136	0.133	0.142	0.142	0.142
		AA	169			114			214			368		
$d_A = 1.5$			13 IPM (2A)											
35	.125	T	0.113	0.113	0.113	0.120	0.120	0.121	0.130	0.130	0.131	0.135	0.135	0.136
		B	0.127	0.124	0.125	0.143	0.143	0.147	0.165	0.165	0.167	0.181	0.178	0.178
		AA	285			322			417			522		
36	.25	T	0.127	0.126	0.126	0.130	0.132	0.132	0.157	0.157	0.157	BROKE CUTTER		
		B	0.148	0.143	0.146	0.163	0.165	0.165	0.213	0.213	0.213			
		AA	142			277			556					
3600 RPM CUTTER 0.75 D x 0.12 R x 2.00 F.L. H.S.S. (2 Flutes) (3-4)														
$d_A = 1.0$			20 IPM (2B)											
37	.125	T	0.097	0.096	0.098	0.105	0.104	0.104	0.109	0.109	0.109	0.111	0.110	0.109
		B	0.109	0.107	0.107	0.116	0.119	0.117	0.125	0.126	0.126	0.129	0.129	0.129
		AA	88			40			180			58		
$d_A = 1.0$			13 IPM (2A)											
38	.375	T	0.102	0.102	0.103	0.106	0.106	0.105	0.114	0.114	0.114	0.117	0.117	0.118
		B	0.106	0.107	0.107	0.114	0.113	0.115	0.134	0.131	0.134	0.136	0.141	0.143
		AA	88			85			222			169		
39	.125	T	0.103	0.103	0.103	0.104	0.104	0.104	0.113	0.112	0.112	0.115	0.116	0.115
		B	0.111	0.111	0.111	0.112	0.113	0.113	0.124	0.124	0.124	0.137	0.131	0.133
		AA	30			138			219			149		
$d_A = 1.5$			20 IPM (2B)											
40	.25	T	0.112	0.111	0.112	0.116	0.116	0.116	0.122	0.122	0.122	0.130	0.130	0.130
		B	0.122	0.121	0.121	0.130	0.130	0.130	0.137	0.139	0.139	0.145	0.145	0.146
		AA	191			192			208			191		
$d_A = 1.5$			13 IPM (2A)											
41	.375	T	0.108	0.108	0.110	0.113	0.114	0.113	0.135	0.135	0.135	0.138	0.139	0.139
		B	0.116	0.116	0.116	0.121	0.127	0.128	0.155	0.155	0.154	0.167	0.167	0.165
		AA	161			158			197			250		
2560 RPM CUTTER 1.00 D x 0.12 R x 2.00 F.L. H.S.S. (2 Flutes) (3-4)														
$d_A = 1.0$			20 IPM (2B)											
42	.05	T	0.096	0.096	0.096	0.096	0.096	0.097	0.097	0.097	0.099	0.100	0.103	0.103
		B	0.100	0.100	0.101	0.102	0.101	0.101	0.102	0.102	0.102	0.107	0.107	0.108
		AA	37			57			42			46		
$d_A = 1.0$			13 IPM (2A)											
43	.375	T	0.104	0.103	0.103	0.111	0.111	0.111	0.114	0.114	0.114	0.114	0.121	0.121
		B	0.105	0.107	0.107	0.114	0.115	0.114	0.126	0.126	0.126	0.133	0.133	0.133
		AA	27			35			38			25		
$d_A = 1.0$			20 IPM (2B)											
44	.50	T	0.118	0.118	0.119	0.116	0.117	0.118	0.123	0.123	0.123	0.127	0.127	0.126
		B	0.128	0.128	0.128	0.131	0.131	0.131	0.139	0.139	0.139	0.148	0.148	0.148
		AA	38			31			47			62		
$d_A = 1.5$			13 IPM (2A)											
45	.05	T	0.098	0.098	0.097	0.104	0.104	0.104	0.108	0.108	0.108	0.108	0.108	0.108
		B	0.098	0.098	0.098	0.104	0.104	0.104	0.105	0.105	0.105	0.105	0.105	0.105
		AA	26			57			40			32		
46	.25	T	0.108	0.109	0.107	0.118	0.115	0.115	0.128	0.129	0.129	0.131	0.130	0.130
		B	0.107	0.107	0.107	0.113	0.113	0.112	0.126	0.126	0.124	0.131	0.131	0.130
		AA	25			26			30			38		

TABLE J-II (CONTINUED)

2560 RPM CUTTER 1.0 D x 0.12 R x 2.00 F.L. H.S.S. (2Flutes) (3-4)														
d _A = x.xx			Measured Thickness and Surface AA - μIn. (1) (6)											
Test No.	Radial Cut	Top/Bot.	Feed			Feed			Feed			Feed		
			L	CL	R	L	CL	R	L	CL	R	L	CL	R
d _A = 1.5			20 IPM (2B)			30 IPM			50 IPM			70 IPM		
47	.375	T	0.121	0.121	0.120	0.122	0.120	0.120	0.128	0.128	0.128	0.132	0.132	0.134
		B AA	0.129	0.128	0.128	0.131	0.131	0.131	0.142	0.142	0.142	0.150	0.151	0.151
			36			49			37			39		
d _A = 1.5			13 IPM (2A)											
48	.50	T	0.115	0.114	0.114	0.132	0.132	0.132	0.158	0.158	0.158	0.164	0.164	0.165
		B AA	0.116	0.116	0.117	0.130	0.132	0.132	0.156	0.156	0.157	0.165	0.166	0.167
			27			25			39			34		
1800 RPM CUTTER 1.5 D x 0.12 R x 2.00 F.L. H.S.S. (2 Flutes) (3-4)														
d _A = 1.0			20 IPM (2P)											
49	.05	T	0.099	0.098	0.098	0.100	0.099	0.099	0.102	0.102	0.100	0.101	0.102	0.101
		B AA	0.102	0.101	0.101	0.102	0.103	0.103	0.104	0.105	0.105	0.105	0.105	0.105
			24			29			29			40		
50	.25	T	0.113	0.114	0.113	0.114	0.115	0.115	0.117	0.117	0.117	0.123	0.123	0.123
		B AA	0.114	0.114	0.114	0.117	0.117	0.116	0.123	0.123	0.122	0.127	0.127	0.127
			31			31			41			50		
d _A = 1.0			13 IPM (2A)											
51	.50	T	0.111	0.108	0.112	0.115	0.115	0.115	0.129	0.129	0.128	0.133	0.132	0.132
		B AA	0.109	0.109	0.109	0.118	0.117	0.116	0.133	0.133	0.133	0.139	0.138	0.139
			22			25			41			41		
52	.75	T	0.126	0.125	0.124	0.131	0.131	0.131	0.134	0.134	0.135	0.143	0.143	0.143
		B AA	0.123	0.123	0.123	0.129	0.129	0.129	0.137	0.137	0.137	0.146	0.146	0.145
			31			26			41			37		
d _A = 1.5			13 IPM (2A)											
53	.05	T	0.104	0.104	0.104	0.109	0.108	0.108	0.113	0.113	0.113	0.108	0.111	0.113
		B AA	0.094	0.097	0.095	0.094	0.094	0.094	0.104	0.105	0.105	0.102	0.102	0.101
			18			19			44			42		
54	.25	T	0.105	0.108	0.106	0.113	0.112	0.112	0.122	0.122	0.123	0.126	0.126	0.126
		B AA	0.110	0.111	0.111	0.116	0.116	0.116	0.125	0.124	0.124	0.128	0.128	0.129
			16			22			46			27		
55	.50	T	0.112	0.112	0.112	0.111	0.112	0.112	0.122	0.122	0.122	0.130	0.131	0.132
		B AA	0.116	0.113	0.114	0.127	0.126	0.127	0.142	0.137	0.140	0.140	0.142	0.141
			24			29			27			35		
56	.75	T	0.115	0.116	0.116	0.122	0.122	0.122	0.135	0.134	0.138	0.153	0.158	0.159
		B AA	0.118	0.118	0.118	0.134	0.135	0.134	0.155	0.155	0.155	0.171	0.172	0.171
			37			20			37			38		
1400 RPM CUTTER 2.0 D x 0.12 R x 2.00 F.L. H.S.S. (2 Flutes) (5)														
d _A = 1.0			10 IPM (2C)											
57	.75	T	0.109	0.109	0.105	0.116	0.116	0.118	0.108	0.107	0.104	0.116	0.116	0.117
		B AA	0.109	0.108	0.106	0.119	0.118	0.120	0.106	0.106	0.106	0.123	0.122	0.124
			17			19			26			24		
d _A = 1.5			10 IPM (2C)			30 IPM			50 IPM			70 IPM		
58	.75	CUTTER DAMAGED AND STIFFENERS FAILED AT 30 AND 50 IPM												
59	.50	T	0.105	0.105	0.102	0.112	0.112	0.114	0.105	0.105	0.106	0.107	0.106	0.108
		B AA	0.116	0.115	0.115	0.125	0.125	0.128	0.112	0.110	0.112	0.131	0.129	0.130
			18			17			32			34		
3600 RPM CUTTER 1.50 D x .12 R x 2.00 F.L. H.S.S. (2 Flutes) 2b														
d _A = 1.5			20 IPM			30 IPM			50 IPM			70 IPM		
60	.25	T	0.102	0.101	0.100	0.105	0.105	0.105	0.108	0.107	0.105	0.110	0.110	0.109
		B AA	0.108	0.107	0.108	0.111	0.110	0.111	0.116	0.118	0.118	0.121	0.121	0.121
			22			28			23			28		
CONVENTIONAL CUT DIRECTION														
61	.25	T	0.098	0.098	0.098	0.092	0.093	0.092	0.084	0.084	0.083	0.096	0.099	0.095
		B AA	0.096	0.097	0.096	0.097	0.098	0.098	0.090	0.090	0.090	0.096	0.096	0.095
			15			14			21			47		
CLIMB CUT 3600 RPM CUTTER 1.00 D x .12 R x 2.00 F.L. H.S.S. (2 Flutes) 2b														
62	.25	T	0.107	0.107	0.107	0.110	0.109	0.110	0.109	0.110	0.110	0.114	0.114	0.113
		B AA	0.107	0.110	0.109	0.113	0.113	0.114	0.116	0.118	0.119	0.120	0.123	0.124
			19			27			24			42		

TABLE J-II (CONTINUED)

3600 RPM CUTTER 1.50 D x .12 R x 2.00 F.L. H.S.S. (2 Flutes) 2b														
63	0.5	T	0.115	0.115	0.115	0.118	0.118	0.119	0.117	0.118	0.116	0.116	0.117	0.115
		B	0.119	0.121	0.121	0.124	0.124	0.124	0.129	0.133	0.132	0.136	0.136	0.135
		AA	20			24			21			25		
3600 RPM CUTTER 2.00 D x .12 R x 2.00 F.L. H.S.S. (2 Flutes) 2b														
64	0.5	T	0.111	0.111	0.111	0.110	0.110	0.108	0.110	0.114	0.117	0.129	0.129	0.130
		B	0.113	0.110	0.111	0.113	0.115	0.115	0.120	0.122	0.126	0.128	0.130	0.130
		AA	16			24			25			16		

- Notes: (1) Thickness measured Top & Bottom, on center of span (C_L) & one inch each side (L,R) of center of stiffener.
- (2) Minimum feed rate
 (a) Morey USA-81240 = 13 IPM
 (b) Morey USA-81215 = 20 IPM
 (c) Bohle = 10 IPM
- (3) Morey N/C Mill USA-81240
 (4) Morey N/C Mill USA-81215
 (5) Bohle Vertical Mill
 (6) Stiffener Nominal Thickness - .100"
 (7) Material - 2124-T851, 2.25" thick plate stock
 (8) d_A = Stiffener height

TABLE J-III ALUMINUM STIFFENER DATA ANALYSIS

Test No.	Cutter Diam. in.	RPM	Axial Cut d _A in.	Radial Cut d _R in.	Area A in. ²	Feed Rate f in./min.	Met. Rem. Rate M <u>cu. in.</u> /min.	Dimensional Quality (+.015, -.010 tol)	
(1)	(2)	(3)	(4)	(5)	(6) (4)x(5)	(7)	(8) (6)x(7)	(9)	
4	2.00	1500	1.5	.05	.075	10	.75	○	
						30	2.25		
						70	5.25		
3	2.00	1500	1.5	.20	.30	10	3.00	○	
						30	9.00		
						50	15.0		
1	2.00	1500	1.5	.50	.75	10	7.5	○	
						30	22.5		
						50	37.5		
2	2.00	1500	1.5	1.00	1.5	10	15	○	
						30	45		
						50	75		
10	2.00	1500	1.5	.05	.075	9	.68	○	
						31	2.33		
						45	3.38		
11	2.00	1500	1.5	.20	.30	9	2.70	○	
						31	9.30		
						45	13.50		
12	2.00	1500	1.5	.50	.75	9	6.75	○	
						31	23.25		
						45	33.75		
13	2.00	1500	1.5	1.00	1.50	9	13.50	○	
						31	46.50		
						45	67.50		
58	2.00	1400	1.5	.75	1.125	10	11.3	operator error	
						30	33.8		operator error
						50	56.3		
59	2.00	1400	1.5	.50	.75	10	7.5	○	
						30	22.5		
						50	37.5		
64	2.00	3600	1.5	.50	.75	20	15.0	○	
						30	22.5		
						50	37.5		
57	2.00	1400	1.0	.75	.75	10	7.5	○	
						30	22.5		
						50	37.5		
5	2.00	1500	1.0	.05	.05	10	.5	○	
						30	1.5		
						50	2.5		
						70	3.5	○	

TABLE J-111 (CONTINUED)

Test No.	Cutter Diam. In.	RPM	Axial Cut d_A in.	Radial Cut d_R in.	Area A in. ²	Feed Rate f in./min.	Net. Rem. Rate M cu. in. min.	Dimensional Quality (4.015, -.010 tol)
(1)	(2)	(3)	(4)	(5)	(6) (4)x(5)	(7)	(8) (6)x(7)	(9)
6	2.00	1500	1.0	.05	.05	9	.45	○
						31	1.55	
						45	2.25	
						63	3.15	
7	2.00	1500	1.0	.20	.20	9	1.80	○
						31	6.20	
						45	9.00	
						63	12.60	
8	2.00	1500	1.0	.50	.50	9	4.5	○
						31	15.5	
						45	22.5	
						63	31.5	
9	2.00	1500	1.0	1.00	1.00	9	9	○
						31	31	
						45	45	
						63	63	
49	1.5	1800	1.0	.05	.05	20	1.0	○
						30	1.5	
						50	2.5	
						70	3.5	
50	1.5	1800	1.0	.25	.25	20	5.0	○
						30	7.5	
						50	12.5	
						70	17.5	
51	1.5	1800	1.0	.50	.50	13	6.5	○
						30	15.0	
						50	25.0	
						70	35.0	
52	1.5	1800	1.0	.75	.75	20	15.0	○
						30	22.5	
						50	37.5	
						70	52.5	
53	1.5	1800	1.5	.05	.075	13	.98	○
						30	2.25	
						50	3.75	
						70	5.25	
54	1.5	1800	1.5	.25	.375	13	4.9	○
						30	11.3	
						50	18.8	
						70	26.3	
55	1.5	1800	1.5	.50	.750	13	9.8	○
						20	22.5	
						50	37.5	
						70	52.5	
56	1.5	1800	1.5	.75	1.125	13	14.6	○
						30	33.8	
						50	56.3	
						70	78.8	
60	1.5	3600	1.5	.25	.375	20	7.5	○
						30	11.3	
						50	18.8	
						70	26.3	

TABLE J-111 (CONTINUED)

Test No.	Cutter Diam.	RPM	Axial Cut $\frac{1}{4}$ in.	Radial Cut $\frac{1}{8}$ in.	Area A (in. ²)	Feed Rate F (in./min.)	Net. Res. Rate M (in./min.)	Dimensional Quality (+.015, -.010 tol)
(1)	(2)	(3)	(4)	(5)	(6) (4)x(5)	(7)	(8) (6)x(7)	(9)
61	1.5	3600 (CONV)	1.5	.25	.375	20	7.5	
						30	11.3	
						50	18.8	
						70	26.3	
63	1.5	3600	1.5	.50	.75	20	15.0	
						30	22.5	
						50	37.5	
						70	52.5	
42	1.0	2560	1.0	.05	.05	20	1.0	
						30	1.5	
						50	2.5	
						70	3.5	
26	1.0	1500	1.0	.25	.25	9	2.3	
						31	7.8	
						45	11.3	
						63	15.8	
43	1.0	2560	1.0	.375	.375	13	4.9	
						30	11.3	
						50	18.8	
						70	26.3	
44	1.0	2560	1.0	.50	.50	20	1.0	
						30	15.0	
						50	25.0	
						70	35.0	
45	1.0	2560	1.5	.05	.075	13	.98	
						30	2.3	
						50	3.8	
						70	5.3	
46	1.0	2560	1.5	.25	.375	13	4.9	
						30	11.3	
						50	18.8	
						70	26.3	
62	1.0	3600	1.5	.25	.375	20	7.5	
						30	11.3	
						50	18.8	
						70	26.3	
47	1.0	2560	1.5	.375	.563	20	11.3	
						30	16.9	
						50	28.1	
						70	39.6	
48	1.0	2560	1.5	.50	.75	13	9.8	
						30	22.5	
						50	37.5	
						70	52.5	
14	0.75	1500	1.0	.05	.05	9	.45	
						31	1.55	
						45	2.25	
						63	3.15	
37	0.75	3600	1.0	.125	.125	20	2.50	
						30	3.75	
						50	6.25	
						70	8.75	

TABLE J-111 (CONTINUED)

Test No.	Cutter Diam. In.	RPM	Axial Cut d_A In.	Radial Cut d_R In.	Area A In. ²	Feed Rate f In./min.	Met. Rem. Rate M cu. in. min.	Dimensional Quality (+.015, -.010 tol)
(1)	(2)	(3)	(4)	(5)	(6) (4)×(5)	(7)	(8) (6)×(7)	(9)
25	0.75	1500	1.0	.25	.25	9	2.25	○
						31	7.75	
						45	11.25	
						63	15.75	
38	0.75	3600	1.0	.375	.375	13	4.88	○
						30	11.25	
						50	18.75	
						70	26.25	
15	0.75	1500	1.5	.05	.075	9	.68	○
						31	2.33	
						45	3.38	
						63	4.71	
39	0.75	3600	1.5	.125	.188	13	2.44	○
						30	5.64	
						50	9.40	
						70	13.16	
40	0.75	3600	1.5	.250	.375	20	7.5	○
						30	11.25	
						50	18.75	
						70	26.25	
41	0.75	3600	1.5	.375	.563	13	7.32	○
						30	16.89	
						50	28.2	
						70	39.4	
31	0.50	3600	1.0	.05	.05	13	.65	○
						30	1.50	
						50	2.50	
						70	3.50	
32	0.50	3600	1.0	.125	.125	20	2.50	○
						30	3.75	
						50	6.25	
						70	8.75	
33	0.50	3600	1.0	.250	.250	13	3.25	○
						30	7.50	
						50	12.50	
						70	17.50	
34	0.50	3600	1.5	.050	.075	20	1.5	○
						30	2.25	
						50	3.75	
						70	5.25	
35	0.50	3600	1.5	.125	.188	13	2.44	○
						30	5.64	
						50	9.40	
						70	13.10	
36	0.50	3600	1.5	.250	.375	13	4.9	○
						30	11.3	
						50	18.8	
						70	26.3	

LEGEND:
 ACCEPTABLE DIMENSIONAL QUALITY
 MINOR REWORK REQUIRED
 FINISH CUT REQUIRED
 UNDERCUT, DAMAGED

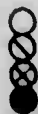

TABLE J-IV MACHINING TEST RESULTS--STIFFENERS--
TITANIUM 6AL-4V b.a.

TEST NO.	dA = x.xx RADIAL CUT	TOP/ BOT.	CUTTER: 2.00 D x 0.12 R x 2.00 F.L., (8 FLUTES) MEASURED THICKNESS AND SURFACE AA, IN.						COMMENTS
			FEED		FEED		FEED		
			L	R	L	R	L	R	
16	0.05	T B AA	3 1/2 IPM						Climb Cut 105 rpm
			L	R	L	R	L	R	
			0.105	0.105	0.109	0.109	0.110	0.111	
17	0.50	T B AA	7 1/2 IPM						Conventional Cut 100 rpm
			L	R	L	R	L	R	
			0.108	0.108	0.113	0.113	0.112	0.113	
18	1.00	T B AA	23H 53V						Conv. Cut 105 rpm
			L	R	L	R	L	R	
			0.114	0.115	0.113	0.113	0.114	0.115	
19	0.05 dA = 1.00	T B AA	56H 115V						Climb Cut 100 rpm
			L	R	L	R	L	R	
			0.097	0.098	0.071	0.073	0.072	0.072	
20	0.50 dA = 1.50	T B AA	83H 112V						Climb Cut 100 rpm
			L	R	L	R	L	R	
			0.080	0.079	0.043	0.043	0.044	0.044	
21	0.25 dA = 1.50	T B AA	85H 89V						Climb Cut 100 rpm
			L	R	L	R	L	R	
			0.165	0.160	0.102	0.102	0.110	0.112	
22	0.05	T B AA	7 1/2 IPM						Climb Cut 100 rpm
			L	R	L	R	L	R	
			0.109	0.108	0.090	0.090	0.102	0.102	
23	0.05	T B AA	32H 51V						Climb Cut 100 rpm
			L	R	L	R	L	R	
			0.155	0.155	0.135	0.133	0.148	0.147	
23	0.05	T B AA	33H 63V						Climb Cut 100 rpm
			L	R	L	R	L	R	
			0.140	0.140	0.135	0.135	0.131	0.132	
23	0.05	T B AA	146H 110V						Climb Cut 100 rpm
			L	R	L	R	L	R	
			0.116	0.116	0.113	0.113	0.110	0.110	
23	0.05	T B AA	CUTTER--0.75 D x 0.12 R x 2.00 F.L. (6 FLUTES)						Climb Cut 100 rpm
			L	R	L	R	L	R	
			0.109	0.109	0.112	0.112	0.113	0.113	
23	0.05	T B AA	52H 67V						Climb Cut 100 rpm
			L	R	L	R	L	R	
			0.102	0.102	0.103	0.103	0.104	0.105	
23	0.05	T B AA	73H 88V						Climb Cut 100 rpm
			L	R	L	R	L	R	
			0.121	0.121	0.123	0.122	0.122	0.123	
23	0.05	T B AA	73H 98V						Climb Cut 100 rpm
			L	R	L	R	L	R	
			0.101	0.102	0.097	0.098	0.097	0.098	

TABLE J-V
MACHINING PARAMETERS FOR SURFACE EFFECT ANALYSIS

<u>Specimen Number</u>	<u>Material</u>	<u>Radial Depth of Cut</u>	<u>Feed Rate in./min.</u>	<u>Avg. Max. Depth of Smearred Metal, in.</u>
2A B C D	2124 Al T851	1"	10	0.00009
			30	.00026
			50	.00042
			70	.00057
4A B C D		.05"	10	.00013
			30	.00029
			50	.00051
			70	.00049
16A B C	Ti-6Al-4V Beta Annealed	.05"	3 $\frac{1}{2}$.00037
			7 $\frac{1}{2}$.00037
			15 $\frac{1}{2}$.00038
18A B C		1"	3 $\frac{1}{2}$.00035
			7 $\frac{1}{2}$.00043
			15 $\frac{1}{2}$.00055

A P P E N D I X K
NC PROGRAMMING DEVELOPMENT TESTS

APPENDIX K
TABLE OF CONTENTS

	<u>Page</u>
1.0 DESCRIPTION OF TESTS	295
2.0 TREATMENT OF DATA	295

APPENDIX K
LIST OF ILLUSTRATIONS

<u>Figure</u>		<u>Page</u>
K-1	NC Programming Development Test Specimen	297
K-2	NC Development Test Specimen, S/N 2	298
K-3	NC Development Test Specimen, S/N 10	299
K-4	Inspection Results, Specimen S/N 2	300
K-5	Inspection Results, Specimen S/N 10	301
K-6	NC Programming Development - Deviation from Drawing Nominal Dimension	302
K-7	NC Programming Development - Quality Comparison	304
K-8	NC Programming Development Tests - Cutter Time Variations	305

APPENDIX K

LIST OF TABLES

<u>Table</u>		<u>Page</u>
K-I	NC Programming Development Tests - Test Programming Features	306
K-II	NC Programming Development - Dimensional Quality Analysis	309
K-III	NC Tests - Evaluation of Quality of Machined Corners	310
K-IV	Quality Comparison NC Test Parts S/N 2 and S/N 10 - Mismatches and Surface Roughness	311
K-V	Quality Comparison - S/N 2 and S/N 10 - Summary, Mismatches and Roughness	311
K-VI	Summary, Overall Quality Comparison - S/N 2 and S/N 10	312

APPENDIX K

NC PROGRAMMING DEVELOPMENT TESTS

Data obtained from the NC Programming Development Tests is presented herein.

1.0 DESCRIPTION OF TESTS

Various programming approaches were used to machine ten simulated production parts of the configuration shown in Figure K-1. The objective was to achieve higher metal removal rates based on the stiffener test data described in Appendix J, while retaining essential quality. The first specimen, S/N 1, was used to proof the basic geometry common to all programmed parts. Due to typical programming errors, the test results from this part were omitted from data analysis.

A description of the various programming features for each specimen evaluated is presented in Table K-I. Part S/N 2 was programmed accordingly to conventional practices while the other specimens utilized increased metal removal procedures.

The last part, S/N 10, was considered the best of the test parts in overall quality and is compared in detail with the conventionally programmed part, S/N 2. Photos of parts S/N 2 and S/N 10 are shown in Figures K-2 and K-3 respectively. Inspection charts for these two specimens are also shown in Figures K-4 and K-5.

2.0 TREATMENT OF DATA

Data obtained from the 9 development test parts are presented in Tables K-II thru K-VI and Figures K-6 thru K-8. Ranges of individual stiffener and web thickness deviation from nominal drawing dimensions are illustrated in Figure K-6. Included in this figure are total machine run times and brief run descriptions. A brief statistical analysis of the dimensional deviations was performed and is presented in Table K-II. The data was analyzed for means and standard deviation for both the high and low points of the dimensional deviation ranges (for stiffeners, webs, and all elements). A graphical analogy of Table K-II results is presented in Figure K-7. The means of the extreme points (high and low) of the individual element dimensional deviation ranges are depicted as points on the line. However, the standard

deviations of these accumulated high and low point values are shown by the length of the dotted lines outside of the mean points. The standard deviation value is understood to extend equally in both directions (positive and negative) from the mean value.

Shown in Figure K-8 is a correlation between cutter time and cutter size for the nine test specimens. Included is a cumulative cutter time for each test. Presented in Table K-III is a relative rating of pocket corner quality for the test parts. Each corner (18 per part) of every test part is ranked as: excellent, acceptable, marginal, or unacceptable.

Tables K-IV, K-V and K-VI present the results of the comparison between parts S/N 2 and S/N 10. Table K-IV shows comparison of corner mismatch and surface roughness values between individual elements (webs and stiffeners) of the two parts. Table K-V summarizes the data of Table K-IV, listing cumulative occurrences, means, and standard deviations of measured values for stiffeners and webs. Finally, Table K-VI provides an overall quality comparison on S/N 2 and S/N 10. Included in this table is the 1σ range of low and high dimensional deviations for stiffeners and webs. This range, bounded by the two listed values, is one within which 68% of all dimensional deviations will fall. Similar values are listed for mismatch and surface roughness.

For interpretation of these results, see Volume I.

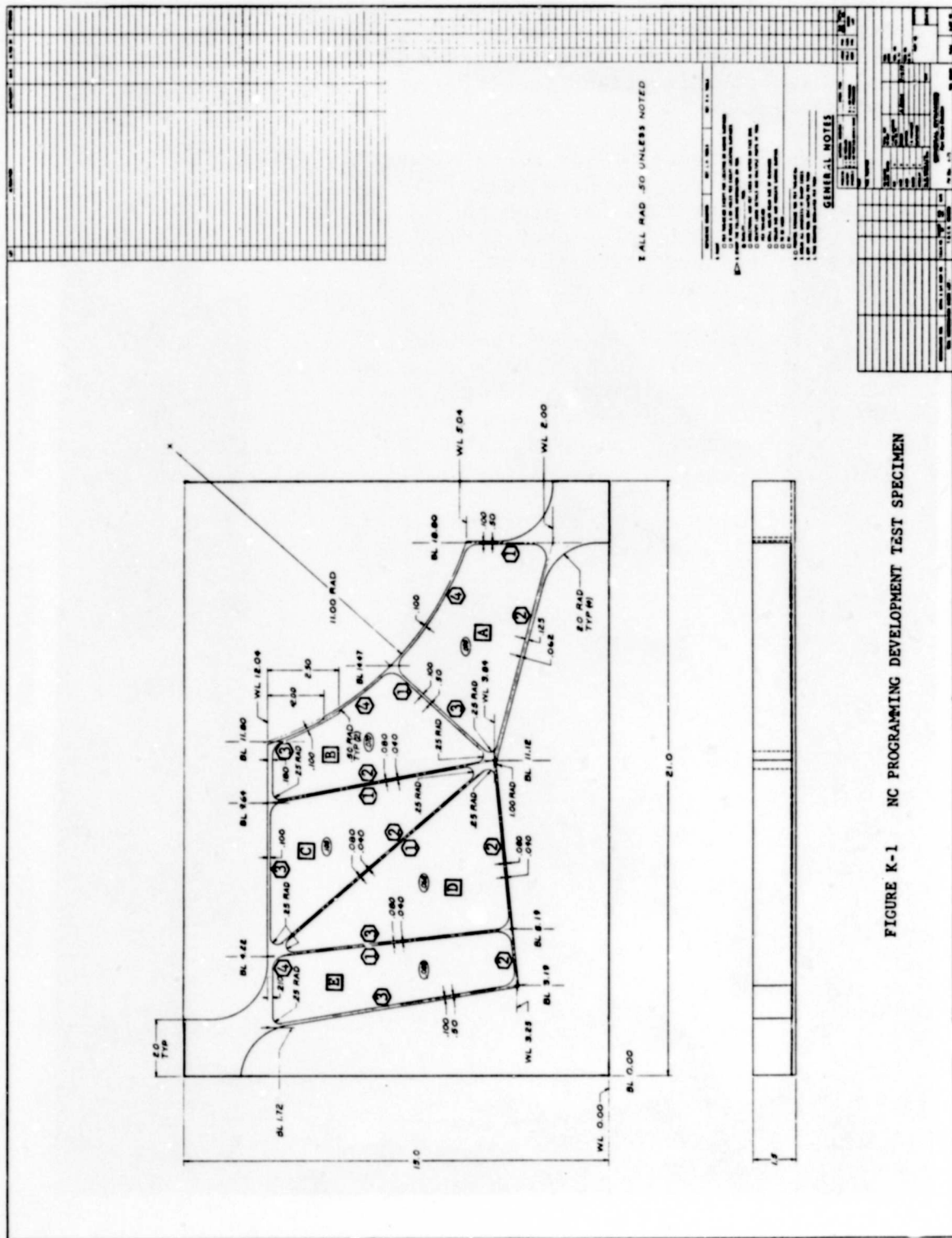

FIGURE K-1 NC PROGRAMMING DEVELOPMENT TEST SPECIMEN

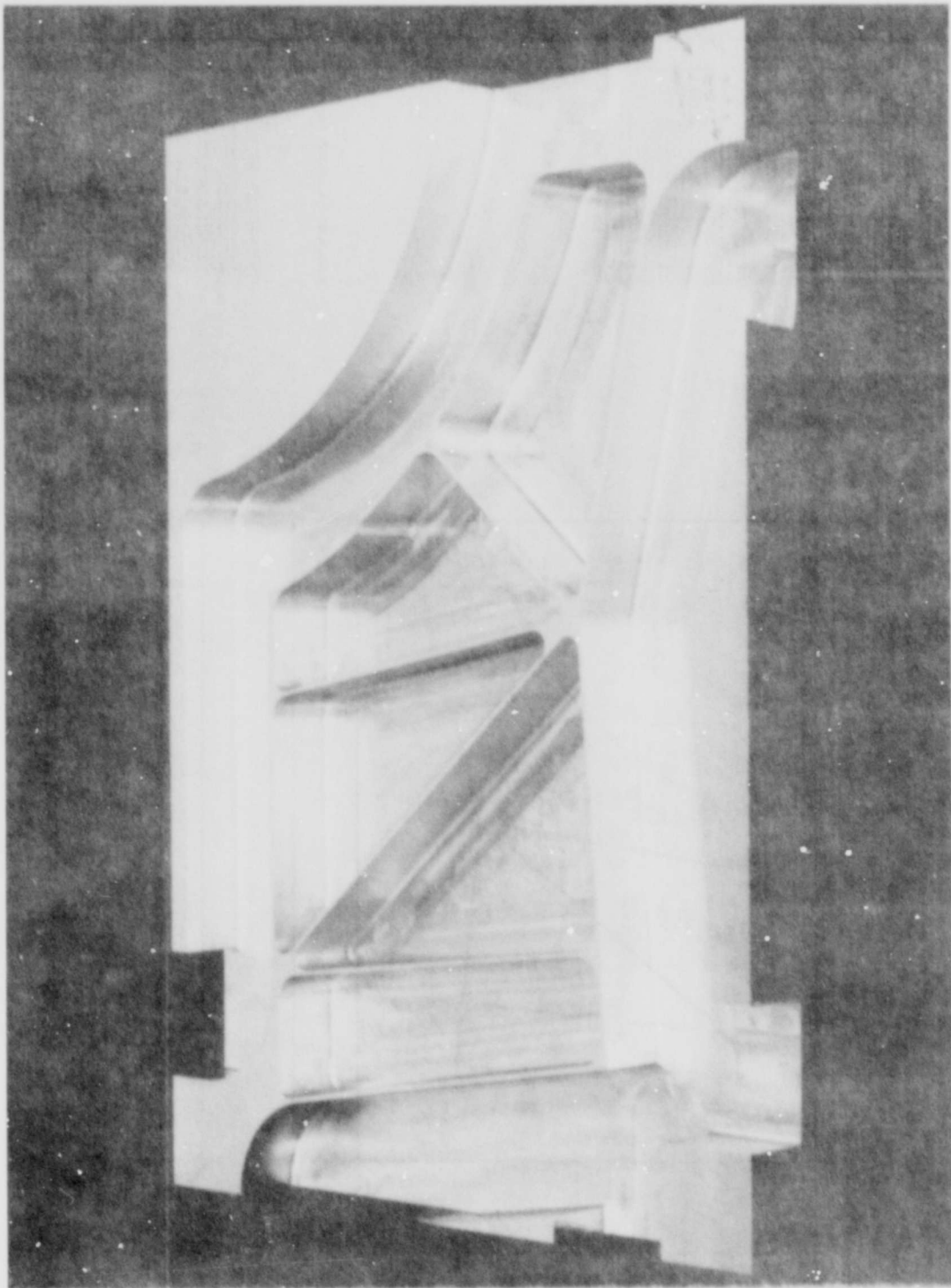

FIGURE K-2 NC DEVELOPMENT TEST SPECIMEN, S/N 2

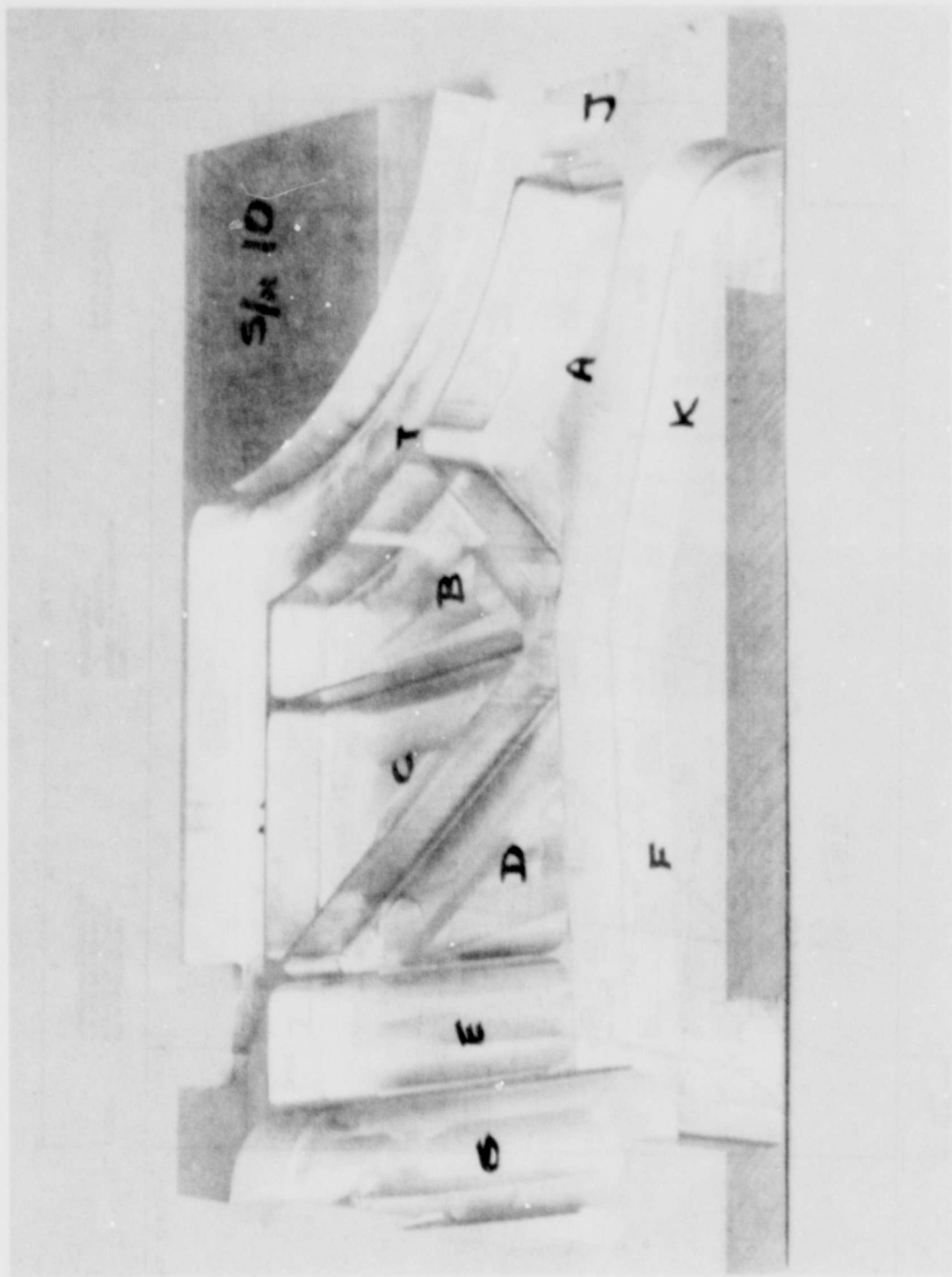
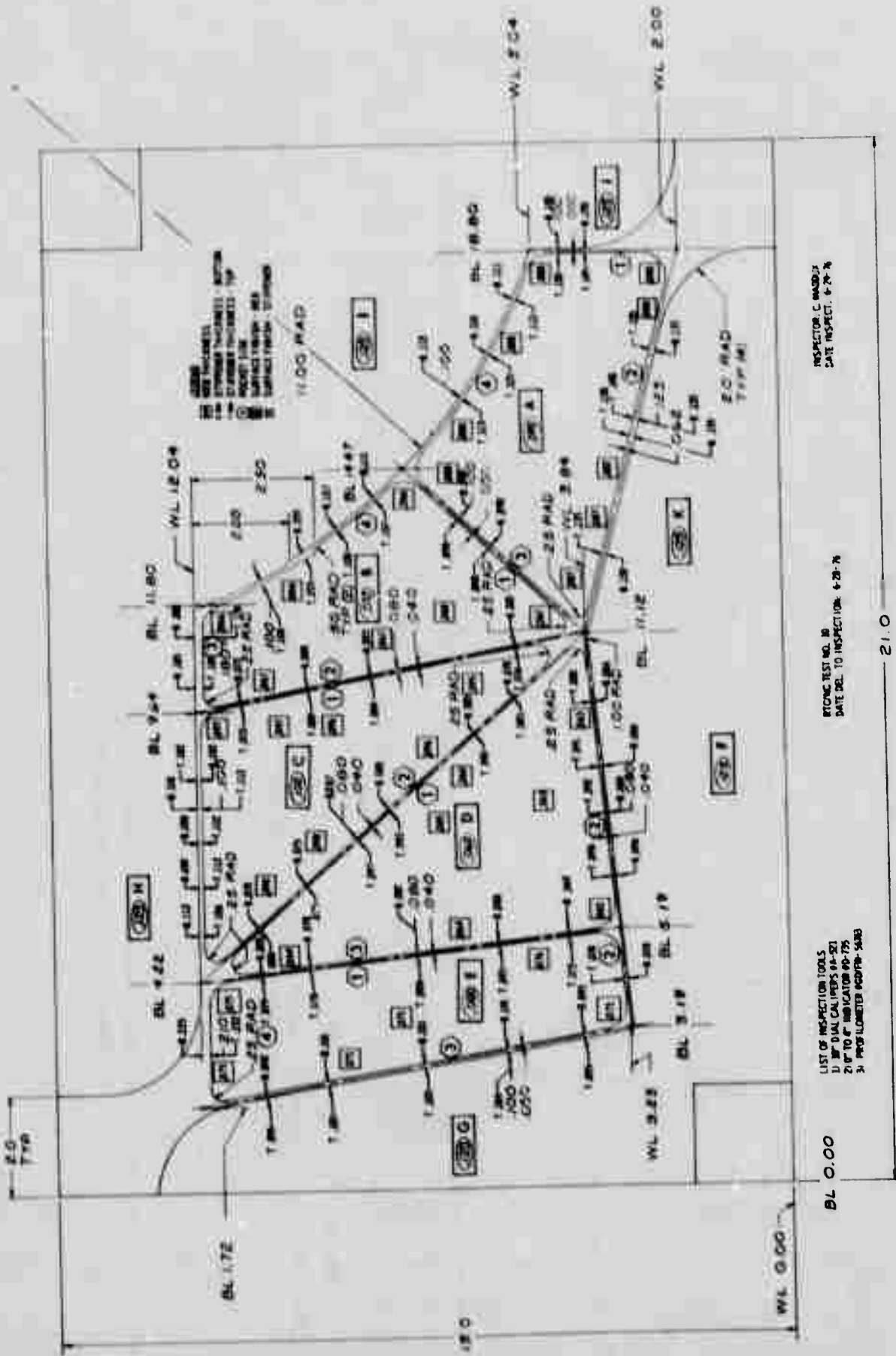

FIGURE K-3 NC DEVELOPMENT TEST SPECIMEN, S/N 10



INSPECTOR: C. WOODRUFF
DATE INSPECT: 6-28-78

RYONG TEST NO. 10
DATE DEL. TO INSPECTION: 6-28-78

- LIST OF INSPECTION TOOLS
- 1) 1" DIAL CALIPERS 8A-91
 - 2) 18" TO 6" INDICATOR 40-75
 - 3) PNEUMATIC PUMP 5483

BL 0.00

21.0

FIGURE K-5 INSPECTION RESULTS, SPECIMEN S/N 10

ELEMENT	DAG	TEST NO. 2 DIMENSIONAL DEVIATION	TEST NO. 3 DIMENSIONAL DEVIATION	TEST NO. 4 DIMENSIONAL DEVIATION	TEST NO. 5 DIMENSIONAL DEVIATION	TEST NO. 6 DIMENSIONAL DEVIATION	
STIFFENER		-0.010 .000 .010 .020 .030	-0.010 .000 .010 .020 .030	-0.010 .000 .010 .020 .030	-0.010 .000 .010 .020 .030	-0.010 .000 .010 .020 .030	
AJ	.160						
AK	.125						
AB	.100						
AI	.100						
BI	.100						
BH	.120						
BC	.045						
CH	.100						
CD	.040						
DF	.020						
DE	.030						
EF	.080						
EG	.100						
FH	.210						
		RANGE OF TOLERANCE					
WEE							
A	.090						
B	.070						
C	.100						
D	.060						
E	.040						
RUN TIME, MIN.		55' - 55"	26' - 30"	(APPROX. SAME AS #3)	25' - 48"	24' - 53"	
RUN DESCRIPTION		CONVENTIONAL PROGRAMMING AND FEED RATES, FOR 1800 RPM, QUALITY FEED RATES	RTC PROG; 2", 1 1/2" D. @ 1800 RPM; RTC CHART FEED RATES	(APPROX. SAME AS #3) RTC PROG; ALL CUTTERS @ 3600 RPM; RTC CHART FEED RATES	SAME AS #4 EXCEPT FEED RATES FROM #4 CHART. SAME RUN IN POWER ON/OFF QUALITY	1. CUT DRILL IN CORNER TO ADD 2. CUT FEED RATES PER TEST CHART 3. FEED RATES FROM 1800 RPM TO 4500 RPM 4. 2250 RPM FOR 2" 3600 RPM FOR 1 1/2"	

FIGURE K-6 NC PROGRAMMING DEVELOPMENT - DEVIATION FROM DRAWING NOMINAL DIMENSION

ELEMENT	DWG	TEST NO. 7 DIMENSIONAL DEVIATION	TEST NO. 8 DIMENSIONAL DEVIATION	TEST NO. 9 DIMENSIONAL DEVIATION	TEST NO. 10 DIMENSIONAL DEVIATION
STIFFENER		- .010 .000 .010 .020 .030	- .010 .000 .010 .020 .030	- .010 .000 .010 .020 .030	- .010 .000 .010 .020 .030
AJ	.100				
AK	.125				
AL	.100				
AM	.100				
AN	.100				
AO	.100				
AP	.100				
AQ	.100				
AR	.100				
AS	.100				
AT	.100				
AU	.100				
AV	.100				
AW	.100				
AX	.100				
AY	.100				
AZ	.100				
BA	.100				
BB	.100				
BC	.100				
BD	.100				
BE	.100				
BF	.100				
BG	.100				
BH	.100				
BI	.100				
BJ	.100				
BK	.100				
BL	.100				
BM	.100				
BN	.100				
BO	.100				
BP	.100				
BQ	.100				
BR	.100				
BS	.100				
BT	.100				
BU	.100				
BV	.100				
BW	.100				
BX	.100				
BY	.100				
BZ	.100				
CA	.100				
CB	.100				
CC	.100				
CD	.100				
CE	.100				
CF	.100				
CG	.100				
CH	.100				
CI	.100				
CJ	.100				
CK	.100				
CL	.100				
CM	.100				
CN	.100				
CO	.100				
CP	.100				
CQ	.100				
CR	.100				
CS	.100				
CT	.100				
CU	.100				
CV	.100				
CW	.100				
CX	.100				
CY	.100				
CZ	.100				
DA	.100				
DB	.100				
DC	.100				
DD	.100				
DE	.100				
DF	.100				
DG	.100				
DH	.100				
DI	.100				
DJ	.100				
DK	.100				
DL	.100				
DM	.100				
DN	.100				
DO	.100				
DP	.100				
DQ	.100				
DR	.100				
DS	.100				
DT	.100				
DU	.100				
DV	.100				
DW	.100				
DX	.100				
DY	.100				
DZ	.100				
EA	.100				
EB	.100				
EC	.100				
ED	.100				
EE	.100				
EF	.100				
EG	.100				
EH	.100				
EI	.100				
EJ	.100				
EK	.100				
EL	.100				
EM	.100				
EN	.100				
EO	.100				
EP	.100				
EQ	.100				
ER	.100				
ES	.100				
ET	.100				
EU	.100				
EV	.100				
EW	.100				
EX	.100				
EY	.100				
EZ	.100				
FA	.100				
FB	.100				
FC	.100				
FD	.100				
FE	.100				
FF	.100				
FG	.100				
FH	.100				
FI	.100				
FJ	.100				
FK	.100				
FL	.100				
FM	.100				
FN	.100				
FO	.100				
FP	.100				
FQ	.100				
FR	.100				
FS	.100				
FT	.100				
FU	.100				
FV	.100				
FW	.100				
FX	.100				
FY	.100				
FZ	.100				
GA	.100				
GB	.100				
GC	.100				
GD	.100				
GE	.100				
GF	.100				
GG	.100				
GH	.100				
GI	.100				
GJ	.100				
GK	.100				
GL	.100				
GM	.100				
GN	.100				
GO	.100				
GP	.100				
GQ	.100				
GR	.100				
GS	.100				
GT	.100				
GU	.100				
GV	.100				
GW	.100				
GX	.100				
GY	.100				
GA	.100				
GB	.100				
GC	.100				
GD	.100				
GE	.100				
GF	.100				
GG	.100				
GH	.100				
GI	.100				
GJ	.100				
GK	.100				
GL	.100				
GM	.100				
GN	.100				
GO	.100				
GP	.100				
GQ	.100				
GR	.100				
GS	.100				
GT	.100				
GU	.100				
GV	.100				
GW	.100				
GX	.100				
GY	.100				
GA	.100				
GB	.100				
GC	.100				
GD	.100				
GE	.100				
GF	.100				
GG	.100				
GH	.100				
GI	.100				
GJ	.100				
GK	.100				
GL	.100				
GM	.100				
GN	.100				
GO	.100				
GP	.100				
GQ	.100				
GR	.100				
GS	.100				
GT	.100				
GU	.100				
GV	.100				
GW	.100				
GX	.100				
GY	.100				
GA	.100				
GB	.100				
GC	.100				
GD	.100				
GE	.100				
GF	.100				
GG	.100				
GH	.100				
GI	.100				
GJ	.100				
GK	.100				
GL	.100				
GM	.100				
GN	.100				
GO	.100				
GP	.100				
GQ	.100				
GR	.100				
GS	.100				
GT	.100				
GU	.100				
GV	.100				
GW	.100				
GX	.100				
GY	.100				
GA	.100				
GB	.100				
GC	.100				
GD	.100				
GE	.100				
GF	.100				
GG	.100				
GH	.100				
GI	.100				
GJ	.100				
GK	.100				
GL	.100				
GM	.100				
GN	.100				
GO	.100				
GP	.100				
GQ	.100				
GR	.100				
GS	.100				
GT	.100				
GU	.100				
GV	.100				
GW	.100				
GX	.100				
GY	.100				
GA	.100				
GB	.100				
GC	.100				
GD	.100				
GE	.100				
GF	.100				
GG	.100				
GH	.100				
GI	.100				
GJ	.100			</	

NC TEST PROGRAMMING NO.	STIFFENERS	VEBS	ALL ELEMENTS	
			- .010 0 +.010	- .010 0 +.010
2	Conventional	Conventional	Conventional	Conventional
3	Combined R/F	Combined R/F	Combined R/F	Combined R/F
4	Combined R/F	Combined R/F	Combined R/F	Combined R/F
5	Combined R/F	Combined R/F	Combined R/F	Combined R/F
6	Separate R/F	Separate R/F	Separate R/F	Separate R/F
7	Separate R/F	Separate R/F	Separate R/F	Separate R/F
8	Combined R/F	Combined R/F	Combined R/F	Combined R/F
9	Combined R/F	Combined R/F	Combined R/F	Combined R/F
10	Separate R/F	Separate R/F	Separate R/F	Separate R/F

RANGE OF TOLERANCE

NOTES: - M = MEAN OF LOW END OF DIMENSIONAL DEVIATIONS SHOWN IN FIGURE
+ M = MEAN OF HIGH END OF DIMENSIONAL DEVIATIONS SHOWN IN FIGURE
- σ = STATISTICAL STANDARD DEVIATION ABOUT - M ON LOW SIDE ONLY
+ σ = STATISTICAL STANDARD DEVIATION ABOUT + M ON HIGH SIDE ONLY
R/V = ROUGH/FINISH MACHINING

FIGURE K-7 NC PROGRAMMING DEVELOPMENT - QUALITY COMPARISON

CUTTER DIA.	SPECIMEN NO.																				
	#2		#3		#4		#5		#6		#7		#8		#9		#10				
	0	5	10	0	5	10	0	5	10	0	5	10	0	5	10	0	5	10	0	5	10
DRILL	~	~	~	~	~	~	~	~	~	~	~	~	~	~	~	~	~	~	~	~	~
2"	8.8 min. 15.6%	3.1 11.7	3.1 11.7	7.8 21.3	3.7 min. 13.8%	3.0 11.2	3.0 11.2	10.6 39.3	10.6 39.3	10.6 39.3	10.6 39.3	10.6 39.3	10.6 39.3	10.6 39.3	10.6 39.3	10.6 39.3	10.6 39.3	10.6 39.3	10.6 39.3	10.6 39.3	10.6 39.3
1 1/2"	13.6 min. 24.3%	10.6 40.1	10.6 40.1	10.6 40.1	10.6 40.1	10.6 40.1	10.6 40.1	10.6 40.1	10.6 40.1	10.6 40.1	10.6 40.1	10.6 40.1	10.6 40.1	10.6 40.1	10.6 40.1	10.6 40.1	10.6 40.1	10.6 40.1	10.6 40.1	10.6 40.1	10.6 40.1
1"	15.1 min. 27.0%	3.3 12.6	3.3 12.6	3.3 12.6	3.3 12.6	3.3 12.6	3.3 12.6	3.3 12.6	3.3 12.6	3.3 12.6	3.3 12.6	3.3 12.6	3.3 12.6	3.3 12.6	3.3 12.6	3.3 12.6	3.3 12.6	3.3 12.6	3.3 12.6	3.3 12.6	3.3 12.6
3/4"	18.5 min. 33.1%	9.5 35.6	9.5 35.6	9.5 35.6	9.5 35.6	9.5 35.6	9.5 35.6	9.5 35.6	9.5 35.6	9.5 35.6	9.5 35.6	9.5 35.6	9.5 35.6	9.5 35.6	9.5 35.6	9.5 35.6	9.5 35.6	9.5 35.6	9.5 35.6	9.5 35.6	9.5 35.6
TOTAL MIN.	55.9	26.5	26.5	36.7	26.9	26.9	26.9	26.9	26.9	26.9	26.9	26.9	26.9	26.9	26.9	26.9	26.9	26.9	26.9	26.9	26.9

FIGURE K-8 NC PROGRAMMING DEVELOPMENT TESTS - CUTTER TIME VARIATIONS

TABLE K-I NC PROGRAMMING DEVELOPMENT TESTS -
TEST PROGRAMMING FEATURES

PART S/N	D _c (IN.)	TYPE CUT	d _R (IN.)	d _A (IN.)	A	f	M	COMMENTS
					d _R x d _A (SQ. IN.)	(IPM)	A x f (CIPM)	
#2	1½	RAMP	1.5	.7	1.05	8	8.4	AVG M.; 1800 RPM AVG M. L'V .050 ON SIDES, WEB 1800 RPM INCL. ½" R. CORNERS INCL. ½" R. CORNERS, USING 0.515"R; 3600 RPM ½"R.CORNERS; 3600 RPM ½"R.CORNERS; 3600 RPM
		SLOT	1.5	.7	1.05	18	18.9	
		ROUGH	VAR.	1.4	--	18	--	
	2	F.WEB	1.5	.050	.075	18	1.4	
		ROUGH	.45	1.5	.68	18	12.2	
	1	F.WALLS	.050	1.5	.075	18	1.4	
		F.WALLS	.037	1.4	.05	18	.9	
	½	F.WALLS	.013	1.4	.018	12	.2	
		ROUGH	VAR.	1.4	--	3	--	
	FIN.	.013	1.4	.018	1.5	.03		
#3	1½	RAMP	1.5	.7	1.05	8	8.4	1800 RPM 1800 RPM CHART FEEDRATE (C.F.) 1800 RPM 3600 RPM 3600 RPM 3600 RPM
		SLOT	1.5	.7	1.05	18	18.9	
		ROUGH	VAR.	1.4	--	18	--	
	2	R/F	.25	1.4	.35	32	11.2	
		R/F	.50	1.5	.75	26-32	24.0	
	1	R/F	VAR.	1.4	≤.18	75	≤13.5	
					≤.38	22	≤8.4	
	½	FR. TRAV.	--	--	>.38	10	≤3.8	
		R/F	VAR.	1.4	≤.3	6	≤1.8	
					≤.5	3	≤1.5	
				>.5	1.5	>.75		
#4	(SAME PROGR. AS #3. ALL CUTTERS @ 3600 RPM)							
#5	1½	RAMP	1.5	.7	1.05	6.4	6.7	3600 RPM; FEED RATES @ 80% OF S/N 3 & 4 3600 RPM; FEED RATE @ 40% OF S/N 3 & 4 3600 RPM; FEED RATE @ 80% OF S/N 3 & 4 100% OF S/N 4 FOR CORN. A2-3, B1-2, B2-3 80% OF S/N 4 FOR CORN. C1-2, C2-3, D1-2 60% OF S/N 4 FOR CORN. D1-3, E3-4 2560 RPM
		SLOT	1.5	.7	1.05	14.4	15.1	
		ROUGH	VAR.	1.4	--	14.4	--	
	2	R/F	.25	1.4	.35	25.6	9.0	
		R/F	.50	1.5	.75	12.8	9.6	
	1	R/F	VAR.	1.4	≤.18	60	≤10.8	
					≤.38	17.6	≤6.7	
	½	FR. TRAV.	--	--	>.38	8.0	>3.0	
		R/F	VAR.	1.4	≤.3	95	--	
					≤.5			
				>.5				

TABLE K-I (Cont'd)

PART S/N	D _c (IN.)	TYPE CUT	d _R (IN.)	d _A (IN.)	A	f	M	COMMENTS
					d _R x d _A (SQ. IN.)	(IPM)	A x f (CIPM)	
#6	7/8 1½	DRILL	--	--	--	--	--	DRILL CORNERS
		RAMP	1.5	.7	1.05	8	8.4	3600 RPM
	2	SLOT	1.5	.7	1.05	18	18.9	LEAVE .050 ON SIDES & WEB
		ROUGH	VAR.	1.4	--	18	--	
	1	FINISH	.050	1.4	.07	75	5.25	3600 RPM
		R/F	.50	1.5	.75	32	24	
	½	R/F	VAR.	1.4	≤.18	75	≤13.5	3600 RPM
					≤.38	22	≤8.4	
				>.38	10	≤3.8		
		FR. TRAV.	--	--	--	95	--	2560 RPM
		R/F	VAR.	1.4	≤.3	6	≤1.8	
				≤.5	?	≤1.5		
				>.5	1.5	>.75		
#7	.437 1½	DRILL	--	--	--	--	--	DRILL CORNERS
		RAMP	1.5	.7	1.05	8	8.4	3600 RPM
	2	SLOT	1.5	.7	1.05	27	28.4	INCR 50% OVER #6
		ROUGH	VAR.	1.4	--	27	--	INCR 50% OVER #6
	1	FINISH	.050	1.4	.07	95	6.65	LEAVE .050 ON SIDES & WEB
			.450	1.5	.68	60	40.5	3600 RPM
	½	R/F	.050	1.5	.075	75	5.63	3600 RPM
			VAR.	1.4	≤.18	95	≤17.1	
					≤.38	33	≤12.6	f INCR BY 50%
					>.38	15	≤5.7	f INCR BY 50%
		RAP. TRAV	--	--	--	95	--	3600 RPM; f INCR BY 50%
	R/F	VAR.	1.4	≤.3	9	≤2.7		
				≤.5	4.5	≤2.3	3600 RPM; f INCR BY 50%	
				>.5				
#8	1½	RAMP	1.5	.7	1.05	8	8.4	3600 RPM
		SLOT	1.5	.7	1.05	18	18.9	
	2	ROUGH	VAR.	1.4	--	18	--	3600 RPM
		R/F	.25	1.4	.35	32	11.2	
	1	R/F	.50	1.5	.75	20	15.0	3600 RPM
		RAP. TRAV	--	--	--	95	--	3600 RPM
	½	R/F	VAR.	1.4	≤.18	75	≤13.5	
					≤.38	22	≤8.4	
					>.38	10	≤3.8	
		RAP. TRAV	--	--	--	95	--	2560 RPM
		R/F	VAR.	1.4	≤.3	6	≤1.8	
				≤.5	3	≤1.5		

TABLE K-I (Cont'd)

PART S/N	D _c (IN.)	TYPE CUT	d _R (IN.)	d _A (IN.)	A d _R x d _A (SQ. IN.)	f (IPM)	M A x f (CIPM)	COMMENTS	
#9	(SAME AS #8, TO OBSERVE REPEATABILITY EXCEPT ½" D CUTTER @ 3600 RPM AND SET WEB CUT .005 HIGHER)								
#10	1½	RAMP	1.5	.7	1.05	8	8.4	3600 RPM	
		SLOT	1.5	.7	1.05	18	18.9		
			ROUGH	VAR.	1.4	--	18	--	LEAVE .050 ON SIDES, WEB SET .005" HIGH
			FINISH	.050	1.4	.07	75	5.25	
		2	ROUGH	.450	1.5	.68	32	21.8	3600 RPM
			FINISH	.050	1.5	.075	75	5.63	
		1	R/F	VAR.	1.4	≤ .18	75	≤ 13.5	3600 RPM
						≤ .38	22	≤ 8.4	
						> .38	10	> 3.8	
		½	FR. TRAV. R/F	VAR.	1.4	≤ 3	6	≤ 1.8	2560 RPM
					≤ 5	3	≤ 1.5		
					> 5	1.5	> .8		

NOTES: d_R - RADIAL CUT
A - AREA OF CUT
M - METAL REMOVAL RATE, CU. IN./MIN.
D_c - CUTTER DIAMETER
d_A - AXIAL CUT
f - FEED RATE, IN./MIN.

TABLE K-II NC PROGRAMMING DEVELOPMENT - DIMENSIONAL QUALITY ANALYSIS

STIFFENER	NC TEST NO.																	
	#2		#3		#4		#5		#6		#7		#8		#9		#10	
	LO	HI	LO	HI	LO	HI	LO	HI	LO	HI	LO	HI	LO	HI	LO	HI	LO	HI
AJ	-.009	+.001	+.001	-.005	+.003	+.003	+.003	+.003	+.003	-.006	-.002	+.001	+.004	+.001	+.004	+.001	+.004	+.005
AK	+.005	+.008	+.016	+.009	+.003	+.017	+.015	+.015	+.015	+.009	+.018	-.002	+.015	+.002	+.015	+.010	+.015	+.015
AZ	-.007	-.004	+.002	+.000	+.005	+.009	+.011	+.011	+.011	-.012	-.008	-.005	+.000	+.000	+.016	+.018	+.010	+.015
AI	-.002	+.003	+.020	+.012	+.010	+.014	+.013	+.013	+.013	-.002	+.002	+.003	+.011	-.004	+.012	+.012	+.006	+.012
BI	-.009	-.004	+.007	+.010	+.005	+.010	+.008	+.008	+.008	+.002	+.006	+.003	+.006	+.005	+.010	+.002	+.005	+.005
BH	+.001	+.004	+.009	+.004	+.012	+.013	+.013	+.012	+.012	+.001	+.005	+.007	+.016	+.005	+.013	+.002	+.008	+.008
BC	-.009	+.002	-.008	+.004	+.005	+.010	+.010	+.010	+.010	+.005	+.005	+.007	+.018	+.005	+.021	+.002	+.002	+.002
CH	+.003	+.005	+.029	+.010	+.015	+.015	+.015	+.012	+.012	+.005	+.014	+.004	+.021	+.005	+.024	+.005	+.005	+.016
CD	-.001	+.008	+.010	+.010	+.017	+.017	+.012	+.012	+.012	+.002	+.007	+.002	+.017	-.002	+.012	+.000	+.000	+.012
DE	-.005	+.000	+.014	+.005	+.010	+.015	+.010	+.010	+.010	+.006	+.008	+.006	+.014	-.008	+.015	-.011	+.011	+.013
DF	-.002	+.003	-.006	+.006	+.005	+.015	+.010	+.010	+.010	+.003	+.004	-.009	+.004	+.004	+.004	-.002	-.002	-.002
EF	-.005	-.003	+.014	+.006	+.008	+.008	+.007	+.007	+.007	-.003	-.004	+.003	+.004	+.004	+.004	-.002	-.002	-.002
EG	-.008	-.004	+.005	+.005	+.014	+.016	+.016	+.016	+.016	+.001	+.006	+.002	+.014	+.000	+.016	+.008	+.008	+.005
EH	+.010	+.010	+.020	+.019	+.022	+.021	+.021	+.021	+.021	+.019	+.015	+.013	+.018	+.018	+.020	+.011	+.011	+.015
MEAN	-.003	+.002	+.010	+.007	+.013	+.012	+.012	+.012	+.012	+.003	+.006	+.000	+.012	+.003	+.013	+.000	+.000	+.003
σ	-.006	+.005	-.010	-.006	+.007	+.007	+.005	+.005	+.005	-.007	+.007	-.007	+.006	-.007	+.006	-.007	+.007	+.007
RES																		
A	-.012	+.001	-.002	-.002	-.006	-.002	-.002	-.002	-.002	-.009	-.003	-.005	-.005	-.005	-.002	-.003	-.003	-.001
B	-.011	+.001	-.005	-.007	-.010	-.007	-.008	-.008	-.008	-.010	-.005	-.005	-.005	-.005	-.008	-.004	-.004	-.001
C	-.013	+.000	-.002	-.008	-.008	-.006	-.008	-.008	-.008	-.009	-.005	-.005	-.005	-.005	-.003	-.004	-.004	-.001
D	-.015	+.000	-.004	-.006	-.010	-.006	-.008	-.008	-.008	-.007	-.005	-.004	-.004	-.004	+.001	+.005	+.003	+.005
E	-.010	+.000	-.001	-.011	-.011	-.002	-.002	-.002	-.002	-.007	-.005	-.005	-.005	-.005	-.007	-.007	-.007	-.005
MEAN	-.012	+.000	-.002	-.003	-.009	-.006	-.007	-.007	-.007	-.008	-.005	-.005	-.005	-.005	-.004	-.001	-.003	-.001
σ	-.002	+.000	-.002	+.002	-.002	+.003	+.003	+.001	+.001	-.001	+.001	+.001	+.001	+.001	-.004	+.004	+.004	+.004
TOTAL MEAN	-.005	+.002	+.007	+.004	+.003	+.008	+.008	+.008	+.008	-.002	+.003	-.001	+.008	-.001	+.008	+.010	+.009	+.007
TOTAL σ	-.006	+.004	-.010	-.008	+.010	+.009	+.009	+.009	+.009	-.007	+.008	-.005	+.009	-.005	+.008	-.007	+.008	+.008

TABLE K-III NC TESTS-EVALUATION OF QUALITY OF MACHINED CORNERS

CORNER LOC.	RADIUS (IN.)	SPECIMEN NO.																	
		2		3		4		5		6		7		8		9		10	
		D	S	D	S	D	S	D	S	D	S	D	S	D	S	D	S	D	S
A 1-2	.50	A	X	B	A	A	C	A	A	A	C	A	A	A	A	A	A	A	A
A 2-3	.25	A	X	A	C	A	C	A	A	A	C	A	A	A	A	A	A	A	A
A 3-4	.50	B	A	B	A	A	A	A	A	A	A	A	A	A	A	A	A	A	A
A 4-1	.50	B	A	B	A	A	A	A	A	A	A	A	A	A	A	A	A	A	A
B 1-2	.25	A	X	A	X	B	X	A	X	A	X	A	X	A	X	A	X	A	X
B 2-3	.25	A	X	A	X	A	X	A	X	A	X	A	X	A	X	A	X	A	X
B 3-4	.50	A	A	A	A	A	A	A	A	A	A	A	A	A	A	A	A	A	A
B 4-1	.50	A	A	B	A	A	A	A	A	A	A	A	A	A	A	A	A	A	A
C 1-2	.25	A	X	A	B	A	C	A	C	A	C	A	C	A	C	A	C	A	C
C 2-3	.25	A	X	A	C	A	C	A	C	A	C	A	C	A	C	A	C	A	C
C 3-1	.50	A	A	A	A	A	A	A	A	A	A	A	A	A	A	A	A	A	A
D 1-2	.25	A	X	A	X	A	X	A	X	A	X	A	X	A	X	A	X	A	X
D 2-3	.50	A	A	B	A	A	A	A	A	A	A	A	A	A	A	A	A	A	A
D 3-1	.25	A	X	A	C	A	C	A	C	A	C	A	C	A	C	A	C	A	C
E 1-2	.50	A	A	A	A	A	A	A	A	A	A	A	A	A	A	A	A	A	A
E 2-3	.50	A	A	A	A	A	A	A	A	A	A	A	A	A	A	A	A	A	A
E 3-4	.25	A	X	A	C	A	C	A	C	A	C	A	C	A	C	A	C	A	C
E 4-1	.50	A	A	A	A	A	A	A	A	A	A	A	A	A	A	A	A	A	A
			8X		3X		2X		5X		3X		2X		8X		7X		2X

X = UNACCEPTABLE, REQUIRES HAND-FINISH OR QA ACTION

A = EXCELLENT
B = ACCEPTANCE
C = MARGINAL

D = DIMENSIONAL QUALITY
S = SURFACE QUALITY

TABLE K-IV QUALITY COMPARISON NC TEST PARTS S/N 2* AND S/N 10*
MISMATCHES AND SURFACE ROUGHNESS

Stiffeners	Mismatches ($\times 10^{-3}$)** (Two Sides, Two Ends)				Surface Roughness, μ AA (Side 1/Side 2)	
	S/N 2		S/N 10		S/N 2	S/N 10
	AK	7/0	0/3	11/5	0/0	28/19
AJ	4/0	0/0	0/0	0/0	31/25	28/23
AI	0/2	0/0	3/0	0/0	26/30	25/14
AB	0/0	0/2	0/0	15/0	38/36	33/26
BI	0/2	0/0	5/0	0/0	20/32	28/15
BH	0/0	0/0	4/0	0/0	42/16	27/39
BC	7/0	0/3	0/6	7/10	34/42	27/25
CH	7/0	0/0	7/0	0/0	32/15	40/38
CD	0/4	4/0	0/12	11/0	30/30	25/28
DE	5/0	0/0	6/15	12/0	28/62	23/39
DF	0/9	0/0	8/9	0/0	24/17	34/26
EG	4/0	0/0	12/9	0/0	26/17	24/21
EF	0/0	0/0	0/8	0/0	41/21	35/20
Webs	Mismatches $\times 10^{-3}$				Surface Roughness, μ AA	
A	2		11,2,4,6,6		40	159
B	4		5,8,5,8,7		32	57
C	7,1,1		4,3,3,5		34	123
D	2,3		7,8,2,6		30	70
E	0		6,6,7,8		19	139

* S/N 2 was machined by commonly used programming procedures.
S/N 10 was machined at an average of 200% of the metal removal rate of S/N 2.

** Example: Stiffener AK (of S/N 2) had mismatch of 0.007 on one end of one side and 0.000 on the other end, and 0.000 and 0.003 on the ends of the other side.

TABLE K-V QUALITY COMPARISON - S/N 2 AND S/N 10 -
SUMMARY, MISMATCHES & ROUGHNESS

Element	Mismatches						Surface Roughness μ AA			
	S/N 2			S/N 10			S/N 2		S/N 10	
	Occur- rences	Mean	σ	Occur- rences	Mean	σ	Mean	σ	Mean	σ
Stiffeners	14	.0012	.0023	20	.0034	.0048	29.3	10.4	27.5	6.9
Webs	7	.0025	.0022	22	.0058	.0022	31.0	7.7	109.6	44.2

TABLE K-VI SUMMARY, OVERALL QUALITY COMPARISON - S/N 2 AND S/N 10

ELEMENT	DIMENSIONS (IN.) (2) (MEAN + 1σ) (1) LOW HIGH	MISMATCHES (IN.) (3) (MEAN + 1σ)	MISMATCH OCCURRENCES (3) NUMBER	SURFACE ROUGHNESS μAA (3) (MEAN + 1σ)	CORNERS REJECTED (4)
STIFFENERS					
S/N 2	-.009 +.007	.0035	14	39.7	8
S/N 10	-.007 +.016	.0082	20	34.4	3
WEBS					
S/N 2	-.014 .000	.0047	7	38.7	
S/N 10	-.007 +.003	.0080	22	153.8	

NOTE: 1. MEAN + 1σ SHOWS THE MEAN PLUS A REPRESENTATION OF THE VARIATION ABOUT THE MEAN. A 1σ RANGE ADDED TO THE LOW MEAN AS WELL AS TO THE HIGH MEAN INCLUDES 68% OF ALL PREDICTED DIMENSIONAL DEVIATIONS, I.E., 68% OF ALL DIMENSIONAL DEVIATIONS FROM THE NOMINAL IN S/N 2 FALL BETWEEN -.009 AND +.007.

2. SEE TABLE K-II
3. SEE TABLE K-IV
4. SEE TABLE K-III

A P P E N D I X L

RTC RE-PROGRAMMING AND
MACHINING OF F-16 PRODUCTION PARTS

APPENDIX L
TABLE OF CONTENTS

	<u>Page</u>
1.0 NC PROGRAMMING/MACHINING GUIDELINES AND APPLICATION	317
1.1 NC Programming/Machining Guidelines	317
1.2 Typical NC Programming Comparison	322
2.0 MACHINING AND DATA ANALYSIS - 16B5222-7	322
2.1 Machining	322
2.2 Quality Comparison	322
2.3 Machining Time Comparison	323
3.0 MACHINING AND DATA ANALYSIS - 16B1262-21	325
3.1 Machining	325
3.2 Quality Comparison	325
3.3 Machining Time Comparison	325

APPENDIX L
LIST OF ILLUSTRATIONS

<u>Figure</u>		<u>Page</u>
L-1	Production Drawing - F-16 Part 16B5222	327
L-2	RTC/NC Machined Part - 16B5222-7	329
L-3	Production Drawing - F-16 Part 16B1262	331
L-4	RTC/NC Machined Part - 16B1262	333

APPENDIX L
LIST OF TABLES

<u>Table</u>		<u>Page</u>
L-I	Typical NC Programming Comparison	334
L-II	Quality Comparison - 16B5222-7	335
L-III	Machining Time Comparison - 16B5222-7	336
L-IV	Quality Comparison, 16B1262	337
L-V	Machining Time Comparison - 16B1262	338

APPENDIX L

RTC RE-PROGRAMMING AND MACHINING OF F-16 PRODUCTION PARTS

Data obtained from re-programming F-16 production parts to the RTC NC programming guidelines is presented herein.

1.0 NC PROGRAMMING GUIDELINES AND APPLICATION

NC programming guidelines were based on the NC development tests described in Appendix K and modified during the machining of the first production part, 16B5222-7. These guidelines are presented below. A comparison with typical conventional programming is also provided.

1.1 NC Programming/Machining Guidelines

The following guidelines were developed by experienced F-16 NC programmers and will be used on F-16 parts as re-programming opportunities are encountered.

PROGRAMMING/MACHINING GUIDELINES FOR NUMERICAL CONTROLLED MILLED ALUMINUM AS DEVELOPED BY THE RELAXED TOLERANCE CONCEPTS PROGRAM

Relaxed Tolerance Concepts (RTC) guidelines have been developed in order to lower the cost of machined parts and to reduce the time for a part on the numerical controlled (NC) machine. Simultaneous with the development of these guidelines, design and surface smoothness requirements have also been relaxed which permits more effective implementation of the guidelines.

The recommended procedures are not designed for use across the entire spectrum of NC machining but are intended only to serve as a guide within the limitations set forth below; most designs, however fall within this scope.

Use of the RTC guidelines presupposes a thorough knowledge of APT (Automatically Programmed Tool) part programming and traditional NC machining techniques.

Basic Concept

In general, RTC machining/programming practices apply exclusively to the milling of aluminum material and only then when the depth of material removed does not exceed 1.75 inches. The basic philosophy is to remove as much material as practical with large (1.75 - 2.00 inch diameter) cutters, finish mill using an intermediate size (1.00 - 0.75 inch diameter) cutter and utilize smaller (.5 - .75 inch diameter) cutters only when absolutely necessary.

Cutter Selection

When machining, always utilize the largest diameter cutter with the shortest flute length possible. This selection will ensure minimal cutter deflection. Undersize cutters may be employed for roughing operations but standard size cutters are mandatory for finishing operations.

Cutter Changes

Utilize as few cutters as possible and organize machining operations in such a manner as to ensure a minimal number of cutter changes.

Positioning

For positioning the cutter (lifting, plunging or traversing) when not removing material, always utilize the maximum feed-rate allowable. Whenever possible, maintain no greater than 0.1 inches clearance for traversing above or positioning to the workpiece. Naturally, exceptions are permissible for certain part configurations and for obstructions such as strap clamps, hold down bolts, locating pins or other tooling accessories. Positioning the cutter without removing metal should be kept to a minimum. When using MACRD, LOOPS, etc., these should be designed to function with the least amount of wasted motion possible.

Ramping

Pocket milling should be initiated by means of a ramping operation. The ramp cut should begin at one extremity of the pocket on a plane 0.1 inches above the workpiece and end 0.05 inches from the desired web and 0.03 inches from the opposite pocket extremity. Once the proper depth has been reached, the cutter should be retraced (at depth) along the line of the ramp cut to the original position less 0.03 inches. A ramping feedrate should be utilized. If pocket size compels an absolutely vertical cut, the feedrate should be reduced to 1/2 the designated ramping feedrate.

Rough Machining

When rough machining with large cutters, excess stock should be left on stiffener and flange walls, as well as on pocket webs. Excess stock of 0.03 inches should be maintained on pocket webs. Conventional milling is permissible but not desirable. Cutter path should be programmed to remove as much material as possible with the least amount of motion, but radial cuts should not exceed 1/2 the diameter of the cutter and axial cuts should not exceed 1.75 inches in depth. Roughing feedrates should be utilized. In instances where the cutter becomes as much as 50 per cent enveloped by material, the feedrate should be temporarily reduced to 1/2 the designated roughing feedrate. A finish pass to the net web dimension should then be made using finishing feedrates. Normally, no finish cuts on stiffener or flange walls should be made. The table shown below gives rough machining feed rates and RPM that may require up to 15 spindle horsepower.

Climb Milling

Always remove material when finish machining by means of climb milling. This convention minimizes cutter deflection and reduces the possibility of undercutting.

Cornering

Do not develop circles for finishing corner radii. Always drive the cutter directly to the adjacent (check) surface which forms the corner. Do, however, use the special feedrate option of APT for slowing the cutter to a cornering feedrate when within 0.05 inches of the adjacent surface.

Feedrate Acc/Dec

For NC systems which control machine tool velocity by means of acceleration and deceleration stepping functions, velocity step size should be increased to at least 35 inches per minute when finish milling. The use of increased acceleration and deceleration step size reduces the possibility of marking stiffener and flange walls as the cutter dynamically changes velocity. Probability of cutter overshoot when cornering is increased, but proper use of the special feedrate option of APT will compensate for this condition.

Small Radius Corners

Small cutters should be used only for machining corner radii except when part configuration dictates otherwise. Two passes to net corner dimensions should be made and cornering feedrates should be used. Corners less than 90 degrees may require additional passes and/or reduced feedrates. When positioning from one corner to the next, the cutter should rapid-traverse free of material.

Mating Surface Milling

In order to ensure satisfactory joining surface quality when milling mating surfaces (usually outside flange peripheries), conservative machining practices should be adopted in lieu of relaxed tolerance concepts. As a general rule of thumb, external milling of outside flange peripheries should be performed prior to internal machining operations.

Control of Surface Roughness

Programming with the rates of the following table will normally produce a surface with roughness well within 125 μ AA for surfaces cut with the side of a 2" F.L. end-mill; however, surfaces such as webs produced by the end of the end-mill may occasionally fall between 125 and 200 μ AA. This condition is usually acceptable in non-functional areas, but may require lower feed rates for areas requiring a 125 μ AA maximum.

Form Cutters

The use of form cutters such as cone, bell and "T" configurations will necessitate special consideration. In general, form cutters do not remove material as effectively as standard cutters, therefore, reduced spindle speeds and conservative feedrates will be necessary. In all cases where form cutters are required, as much material as possible should first be removed with a standard cutter.

Spindle Speeds and Feedrates

The following table specifies spindle speeds and milling feedrates which should be employed for RTC programming:

Flute Length	Type of Cut	END MILL DIAMETER							
		1/2"		3/4"		1"		1 1/4"-2"	
		RPM	IPM	RPM	IPM	RPM	IPM	RPM	IPM
Through 2"	Rough	--	--	--	--	1800	20	3600	40
	Finish Walls	2560	10	1800	20	1800	35	--	--
	Finish Webs	--	--	--	--	1800	35	3600	75
	Ramping	--	--	1800	10	1800	10	3600	15
	Cornering	2560	3	1800	8	1800	10	3600	20

Operator Control

The feed rates of the above table are to be adhered to by the operator without over-ride unless machine malfunction is encountered. Furthermore, where machine tool spindle RPM is not controlled via NC tape, RPM must be reflected on the operator instruction document. Machining will therefore be entirely tape or computer controlled. The operator should be so instructed on the instruction document.

1.2 Typical NC Programming Comparison

Table L-I describes the NC programming of a F-16 production part, as it was originally done, with metal removal rates typical in much of the industry, and also as re-done for the RTC program using the feeds and speeds developed during this program.

2.0 MACHINING AND DATA ANALYSIS - 16B5222-7

Discussion on machining and analysis of F-16 fuselage frame 16B5222-7 shown in Figures L-1 and L-2 is given below.

2.1 Machining

Machining of the seven pieces of 16B5222-7 was done on 3 axis mill Lucas-Morey No. 11. Maintenance of the machine was checked before and during the machining period. Coolant lines were cleaned and travel was checked. Spindle horsepower was monitored to insure that the higher metal removal rates did not represent an excessive demand. The highest demand was 26 hp., encountered during ramping with a 1½" cutter. This is an increase of 16 hp. over the free wheeling value of 10 hp. Production vacuum chuck tooling was used and vacuum read 24 inches of mercury throughout the tests.

2.2 Quality Comparison

Table L-II summarizes the contents of Quality Assurance Reports for three pieces of 16B5222-7 programmed conventionally for production and seven RTC pieces re-programmed to RTC guidelines. The first few RTC pieces exhibited an excessive number of dimensional discrepancies as well as surface waviness. This quality was not significantly different from the three production parts, but better performance was desired so the guideline

feedrates and RPM values were modified so as to be more conservative. The last three pieces were considered adequate in quality, and the guidelines were finalized as presented above.

The first RTC part was scrapped due to the programming errors but later used for the F-16 metal mockup. The remaining six pieces were accepted and placed in F-16 production stock.

2.3 Machining Time Comparison

Table L-III lists the total time on the NC mill for 16B5222-7 for each of the various basic activities such as tool set-up and tear-down, cutter and clamp changes and actual cutting time. Values for cutting time are based on NC tape time for the F-16 production programmed part - conservative, since the operator has the common practice option of slowing down the machine by over-riding the tape. Cutting time and other functions for the RTC parts were actual measured intervals using a stop watch. For the RTC parts, no operator over-ride was permitted, so tape and running times were identical. RPM was provided the operator on the NC specification for the part.

In view of the absence of measured time intervals for the non-cutting functions for the production part, the RTC-measured time intervals were assumed applicable to the production part also. There is no basic reason for any difference in these functions between the two parts. As can be seen in Table L-III, wide variations exist from part to part in the time required for the non-cutting activities depending upon whether the tooling was still in place from the previous part or how well the operator maintained his efficiency in making clamp and cutter changes.

Since, on a complex part such as 16B5222-7, the cutting time is a large portion of the total time on the machine, the large reduction in cutting time achieved by the RTC guidelines significantly reduced total time on the machine, by an average of 54%. In other terms, the time reduction on the machine is roughly $322-174=148$ minutes, or 2.5 hours.

The difference in tape time, and therefore cutting time for S/N 007 is $206.1-71.6=134.5$ minutes or 2.24 hours. The saving in cutting time is not affected by learning curve influence since tape time is not within operator control; therefore, the benefit of reduced cutting time is a constant value and an increasing percentage of total cost as learning progresses throughout the entire program.

The RTC programming for 16B5222-7 was adopted by the F-16 NC programming group as the final production programming for this part.

3.0 MACHINING AND DATA ANALYSIS - 16B1262

The second F-16 production part selected was programmed in a manner similar to that for 16B5222. Figures L-3 and L-4 illustrate the part. Seven pieces were machined. The second piece was damaged early in machining due to machine malfunction and so is not reported on. The RTC programming for 16B1262 was finally adopted as F-16 production programming.

3.1 Machining

Machining was done on two different mills. The first, Morey mill No. 5, ran at roughly two thirds tape speed. Also, the programming did not comply with the RTC guidelines in cutter selection, cutter motion and feed rates. The part was completed and is reported on in Tables L-IV and L-V. The remaining parts were cut on Lucas-Morey No. 11 (4' x 8' bed), a 30 hp. mill. A peak horsepower of 23 was experienced momentarily during ramping of each pocket with the 1½ inch diameter cutter. Production tooling was used and vacuum read 24 inches of mercury during the tests. Programming was revised to be more compatible with the guidelines.

3.2 Quality Comparison

Table L-IV summarizes the inspection results for three pieces of 16B1262-13 and one piece of -21, all production programmed and machined. Also, six RTC-programmed pieces are reported on, three -21 and three -23. All of these are identical except for minor differences in geometry caused by engineering changes. No significant difference in quality between the four production pieces and the six RTC pieces is apparent; however, RTC programming did produce one part, S/N F219521A, without any dimensional discrepancies. One piece, S/N 004, was finally scrapped after inspection and deliberation on whether or not to repair; however, the decision to scrap was not a reflection on the programming since the cause was a machine malfunction causing the cutter to cut through a flange. A tooling failure delayed resolution of discrepancies on S/N F471743.

3.3 Machining Time Comparison

Table L-V summarizes the machining time for each of the six RTC parts for 16B1262 and compares the time with that required by conventional production programming. The first part, S/N F463031,

was improperly programmed and was run on a malfunctioning machine that ran too slow, resulting in non-typical cutting time. The cutting time for this part was therefore not included in the averages and percentages presented.

The remaining five pieces show an average reduction in cutting time of 119.7 - 56.8 or 62.9 minutes (1.05 hours), an average reduction in cutting time of 53%. The tooling time includes the time required to remove and re-install the tooling, for S/N F219521A, a typical event that needs to be included in order to achieve a realistic comparison of total time on the machine. The reduction in total time is 36%.

The comments made for the first part re-programmed, 16B5222, regarding over-ride conservation on production machining and running the RTC tapes at 100% apply equally to 16B1262.

REV	BY	DESCRIPTION	DATE	APPROVE
1	A	INC ECN 4002		
2	B	INC ECN 4154		
3	C	INC ECN 7171		
4	D	INC ECN 108987		
5	E	INC ECN 15718		
6	F	INC ECN 7679	4-17-76	<i>[Signature]</i>

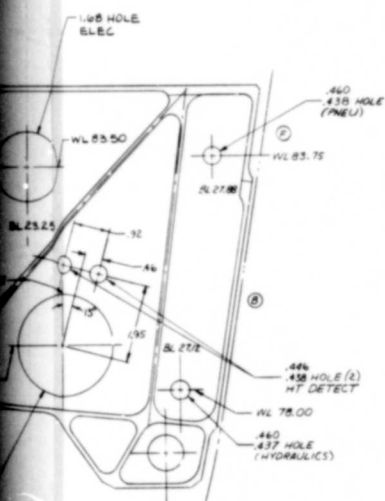

- 1. 'T' DENOTES SURFACES PER MOOI TYPE I AND MISMATCH PER MOOI TYPE III. ALL OTHER SURFACES PER MOOI TYPE II AND MISMATCH PER MOOI TYPE III.
- 2. THICKNESS TOLERANCE FOR ALL FLANGES & STIFFENERS TO BE $\pm .015$
- 3. ALL EDGES DISK OR CHAM $45^\circ \times .015$
- 4. 'G' DENOTES WEB THICKNESS
- 5. PENETRANT INSPECT PER NOTS 1101 ZONE I
- 6. METAL REMOVAL PER SPS-3017
- 7. FOR CONTOUR SEE LINES DATA REPORT 16PRO06, TOL FROM CONTOUR $\pm .010$

NOTES (EXCEPT AS SHOWN)

PART ORG PER MOUNT 16B5222	MATERIAL PARTS PER 16B5222	WEIGHT 16B5222	VOLUME 16B5222	CONTRACT NO 16B5222	GENERAL DYNAMICS Fort Worth Division BULKHEAD SEGMENT, FUSELAGE LOWER, STA 293.80
DATE 16B5222	DRAWN BY 16B5222	CHECKED BY 16B5222	DESIGNED BY 16B5222	MANUFACTURED BY 16B5222	PART NO 16B5222
QUANTITY 16B5222	MATERIAL 16B5222	WEIGHT 16B5222	VOLUME 16B5222	CONTRACT NO 16B5222	GENERAL DYNAMICS Fort Worth Division BULKHEAD SEGMENT, FUSELAGE LOWER, STA 293.80

FIGURE L-1 PRODUCTION DRAWING - F-16 PART 16B5222

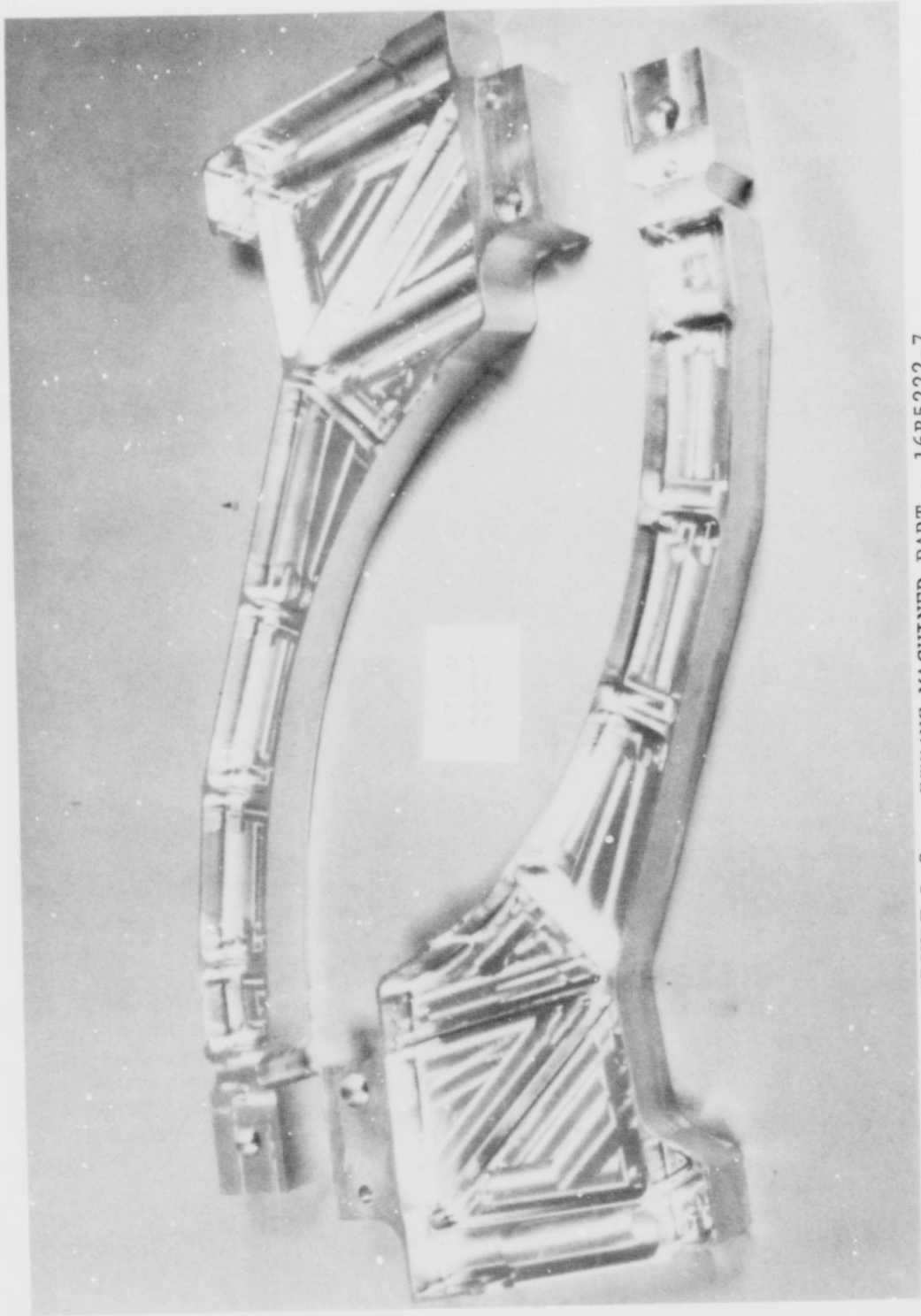
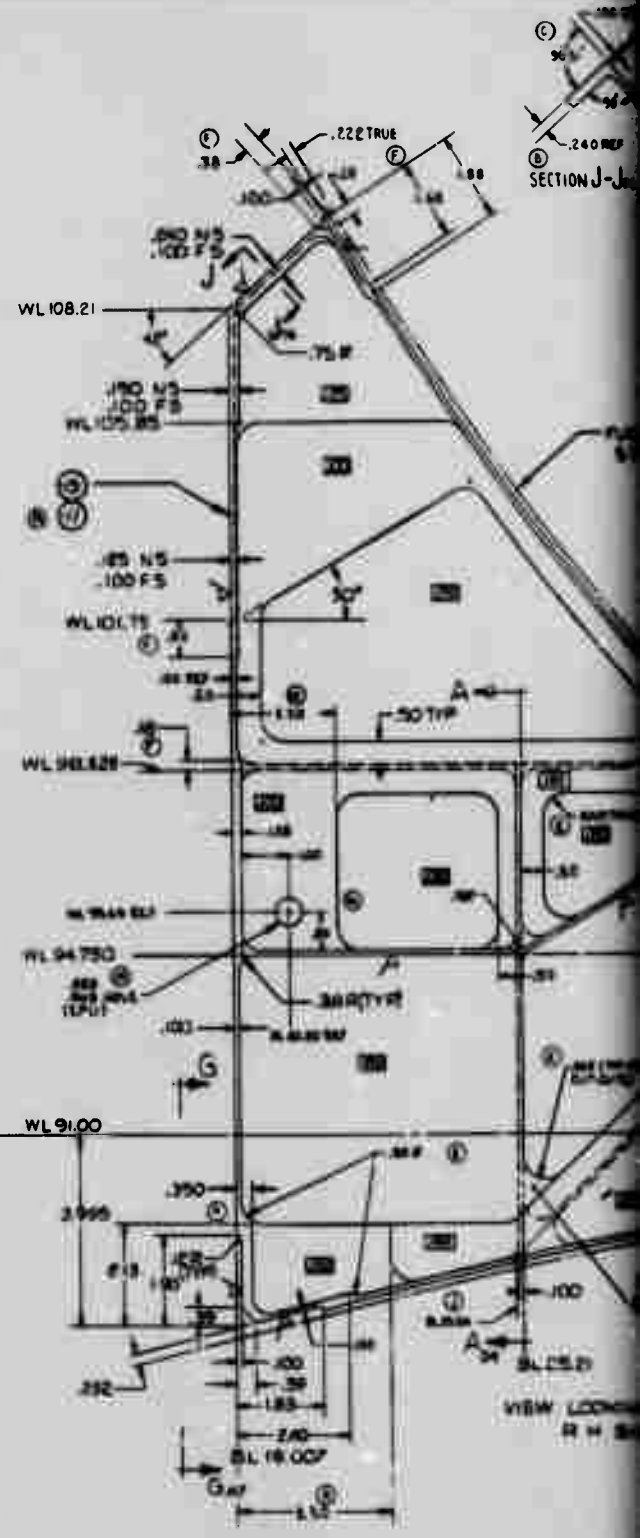
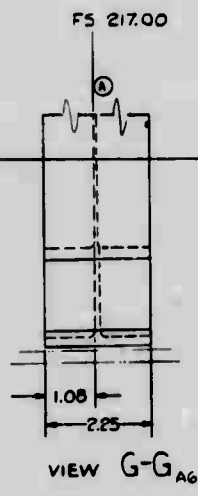

FIGURE L-2 RTC/NC MACHINED PART - 16B5222-7

1701 2251820 101

D
C
B
A

BL 0.00 (REF)



1

REV	DESCRIPTION	DATE	BY	CHKD
A6	INC ECM 4201			
D6	INC ECM 4204			
B6	INC ECM 4278			
A5	INC ECM 4305			
B7	INC ECM 4302			
D6	INC ECM 4717			
A6	INC ECM 4432			
A4	INC ECM 5689			
A6	INC ECM 5166			
B6	INC ECM 8686			
B6	INC ECM 7770			
B6	INC ECM 7807			

7.00

080 REF

.100 TYP

C-C B5
11 612

080 REF
.100
.132 TYP

B-B A5
12 612



H-H B5

.062 FOR +.15 REF
.032 FOR -.11 REF
FS 217.00 REF

SECT H-H

FS 217.00 REF



.062 FOR +.15 REF
.032 FOR -.11 REF

- 10. FWD 4 AFT INTERNA. FLANGE ANGLES TO BE 90° IN THIS AREA
- 12. ALL FORWARD INTERNAL LOWER FLANGE ANGLES SHALL BE 90° EXCEPT OUTBOARD OF BL 32.70 THE ANGLES SHALL BE 80° CONSTANT, UPPER FLANGE ANGLES SHALL BE 90° EXCEPT UPPER INTERIOR CONTOUR ANGLE OUTBOARD OF BL 32.70 MAY BE 90° EXCEPT UPPER INTERIOR CONTOUR ANGLE OUTBOARD OF BL 32.70 MAY BE 94° CONSTANT, ALL FLANGE THICKNESS TO BE MEASURED AT THE THINNEST POINT
- 11. ALL AFT INTERIOR CONTOUR FLANGE ANGLES, UPPER & LOWER, MAY BE 90° EXCEPT UPPER INTERIOR CONTOUR ANGLE OUTBOARD OF BL 32.70 MAY BE 94° CONSTANT, ALL FLANGE THICKNESS TO BE MEASURED AT THE THINNEST POINT
- 10. **W** DENOTES WEB THICKNESS
- 9. FOR FINISH REQUIREMENTS PER FPS 3001 ALL SURFACES ARE EXPOSED SURFACES EXCEPT THOSE NOTED WITH SYMBOL **∇**
- 8. ALL FLANGE TO WEB FILLET RADIUS .12 ALL OTHER FILLET RADIUS .38
- 7. TOLERANCE ON FLANGE THICKNESS $\pm .015$
- 6. PENETRANT INSPECT PER NDT 1101 ZONE I
- 5. VERIFY HEAT TREATMENT PER NDT 1500
- 4. **∇** DENOTES SURFACES PER MDO1 TYPE I AND MISMATCH PER MDO1 TYPE III ALL OTHER SURFACES PER MDO1 TYPE II AND MISMATCH PER MDO1 TYPE IV
- 3. METAL REMOVAL PER FPS 3017
- 2. ALL EDGES .015R OR CHAMFER 45° x .015
- 1. FOR CONTOURS SEE LINES DATA REPORT 16PRO06

NOTES (EXCEPT AS SHOWN)

GENERAL DIMENSIONS		Part Work Group		REV	
BULKHEAD, FUSELAGE		-R H SIDE, FS 21700		J	
REV		REV		REV	
16B1262		16B1262		16B1262	

FIGURE L-3 PRODUCTION DRAWING - F-16 PART 16B1262

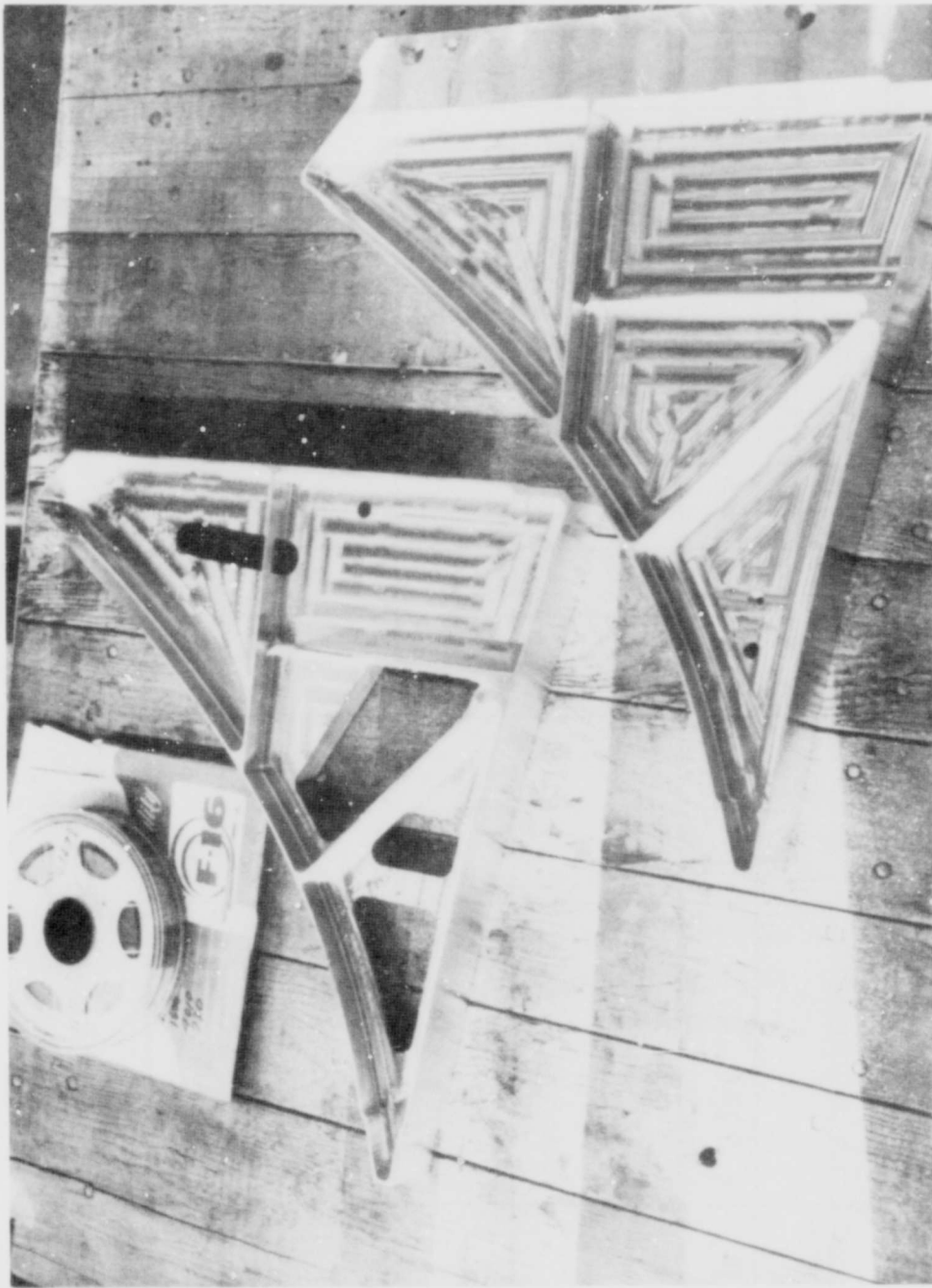

FIGURE L-4 RTC/NC MACHINED PART - 16B1262

TABLE L-I TYPICAL NC PROGRAMMING COMPARISON

P/N 16B5222-7 MATERIAL: 2124-T851

CUTTER DIAMETER (in.)	CUTTER OPERATION	PRODUCTION PROGRAMMING (ALL CUTTERS @ 1800 RPM)					RTC PROGRAMMING					$\frac{M2}{M1}$
		dA	dR	A	f	M1	dA	dR	A	f	M2	
2.0	Slot cut down to top of stiffeners	0.5	2.0	1.0	18	18.0	0.5	2.0	1.0	40	40	2.2
1.5	Ramp into pockets	1.0	1.5	1.5	5	8.0	1.0	1.5	1.5	15	22.5	2.8
	Rough machining	1.0	.75	.75	20	15.0	1.0	.75	.75	40	30	2.0
	Finish web	.05	1.5	.075	20	1.5	.03	1.5	.045	75	3.4	2.3
1.0	Finish sides	1.0	.05	.05	20	1.0	1.0	.05	.05	35	1.8	1.8
	Finish corners	1.0	1.0	1.0	3	3.0	1.0	1.0	1.0	3	3.0	1.0
0.5	Approach corners	1.0	.5	.5	5	2.5	1.0	.5	.5	10	5.0	2.0
	Finish corners	1.0	.5	.5	3	1.5	1.0	.5	.5	3	1.5	1.0
1" cone	Mill 40-30' sides	1.0	.04	.04	20	.8	1.0	.04	.04			
	Rapid traverse x&y				70					95		
	Rapid traverse z				50					50		

Notes: $M = dA \times dR \times f$ where M = metal removal rate, cu. in./min.
 dA = axial cut, in.
 dR = radial cut, in.
 f = feed rate, in./min.

TABLE L-II QUALITY COMPARISON - 16B5222-7

SERIAL NO.	QAR NO.	NUMBER & TYPES OF DISCREPANCIES			COMMENTS	
		DIMENSIONAL	SURFACE	DAMAGE		OTHER
F207460 F-16 Prod. Part	AK47559 16 rejections	15	0	0	1 tape error	8 items - use as is 3 items - rework 4 items - smooth & use
F449945 F-16 Prod. Part	AK47661 9 rejections	5	0	1	2 tape errors	1 item - doubler repair 4 items - use as is 2 items - rework
F207462 F-16 Prod. Part	AK47537	9	1 (cutter run in radius)	0	2 tape errors	7 items - use as is 3 items - rework
F455337 RTC Part S/N 1	AK47702 35 rejections	24	0	1 (web cut thru)*	5 axis tape error	*Tape error-scrapped part. (Used on metal mockup)
F455333 RTC Part S/N 2	AK35278 19 rejections	14	0	1 (rib cut thru)*	5 axis tape error	*Tape error-repaired. Added to F-16 production stock. 14 items - use as is. 3 items - rework to B/P
F455335 RTC Part S/N 3	AK35452 16 rejections	10	2 (excessive waviness)	-	5 axis tape error	10 items - use as is 4 items - rework to B/P 2 items - smooth & use Added to production stock.
F455334 RTC Part S/N 4	AK35399 11 rejections	8	1 (excessive waviness)	-	5 axis tape error	8 items - use as is 3 items - rework to B/P Added to production stock.
F455336 RTC Part S/N 5	AK23950 9 rejections	8	0	-	5 axis tape error	5 items - use as is 3 items - rework to B/P 1 item - smooth and use Added to production stock.
F460852 RTC Part S/N 6	AK28451 16 rejections	13	2 (chatter marks)	-	5 axis tape error	13 items - use as is 2 items - rework to B/P 1 item - smooth & use Added to production stock.
F460853 RTC Part S/N 7	AK28379 7 rejections	6	0	-	5 axis tape error	2 items - use as is 3 items - rework to B/P 2 items - smooth & use Added to production stock.

TABLE L-III MACHINING TIME COMPARISON - 16B5222-7

S/N (1)	TIME, IN MINUTES						
	TOOL SETUP, TEAR-DOWN (2)	CUTTER, CLAMP CHG'S (3)	ACTUAL RTC CUTTING TIME (4)	ACTUAL PRODUCTION CUTTING TIME (5)	COMPARISON, TOTAL TIME		RTC % OF PROD. (8) (6)/(7)
					RTC MINUTES (2)+(3)+(4) (6)	PROD. (7) (2)+(3)+(5)	
001	120.0	42.9	63.6	206.1	226.5	369.0	61%
002	119.0	29.0	60.5	206.1	208.5	354.1	59
003	40.0 ①	27.6	61.0	206.1	128.6	273.7	47
004	122.6	22.2	62.9	206.1	207.7	350.9	59
005	40.0 ①	17.6	62.9	206.1	120.5	263.7	46
006	75.7	11.5	65.9	206.1	153.10	293.3	52
007	②	②	71.6	206.1	—	—	—
MEAN			64.1		174.1	317.5	54

Notes: ① Tooling was in place from previous S/N.
② Data was not measured.

TABLE L-IV QUALITY COMPARISON, 16B1262

PART NO.	SERIAL NO.	QAR NO.	NUMBER & TYPES OF DISCREPANCIES				COMMENTS
			DIMENSIONAL	SP/RFACE	DAMAGE	OTHER	
16B1262-13	F426528 Prod. Part	AK23515 12 Rejections	9	0	1	2 Mislocated Cut	Morey #4 mill malfunctioned Part scrapped
16B1262-13	F426530 Prod. Part	AK23585 7 Rejections	6	0	0	1 Mislocated Cut	6 Items - Use as is 1 Item - Rework to B/P
16B1262-13	F426529 Prod. Part	AK23586 7 Rejections	6	0	0	1 Mislocated Cut	6 Items - Use as is 1 Item - Rework to B/P
16B1262-21	F219521 Prod. Part	AK28156 5 Rejections	5	0	0	0	5 Items - Use as is 1 Item - Smooth and use
16B1262-21	F463031 RTC S/N 001	AK28054 11 Rejections	7	0	0	4 Part was milled to a -15 tape	4 Items - Rework to B/P 2 Items - Rework to -21 & use 3 Items - Use as is 1 Item - Smooth & use
16B1262-21	F463033 RTC S/N 003	AK47466 10 Rejections	7	2	0	Hole not cut clear thru web	2 Items - Use as is 5 Items - Rework to B/P 1 Item - Break sharp edges and smooth & use 2 Items - Smooth & use
16B1262-21	F463034 RTC S/N 004	AK53952	8	1	1	0	Part scrapped. Machine malfunctioned.
16B1262-23	F463035 RTC S/N 005	FAI 3/31/77 See Note (1)	4	0	0	0	Tape acceptable for production.
16B1262-23	F219521A RTC S/N 006	None	0	0	0	0	Tooling positioning error. Status unresolved at time of this report.
16B1262-23	F471743 RTC S/N 007		4	0	0	0	

NOTES: (1) FAI is "First Article Inspection" record, conducted to proof tape before formal inspection.

THIS REPORT HAS BEEN DELIMITED
AND CLEARED FOR PUBLIC RELEASE
UNDER DOD DIRECTIVE 5200.20 AND
NO RESTRICTIONS ARE IMPOSED UPON
ITS USE AND DISCLOSURE.

DISTRIBUTION STATEMENT A

APPROVED FOR PUBLIC RELEASE

DISTRIBUTION UNLIMITED.

TABLE L-V MACHINING TIME COMPARISON - 16B1262

S/N (1)	TIME, IN MINUTES ON 3 AXIS MILL					COMPARISON, TOTAL TIME MINUTES			RTC % OF PROD. (8) (6)/(7)
	TOOL SETUP, TEAR-DOWN (2)	CUTTER, CLAMP CHG'S. (3)	ACTUAL CUTTING TIME (4) ③	ACTUAL PRODUCTION CUTTING TIME (5) ③ ④	RTC (6) (2)+(3)+(4)	PRODUCTION (7) (2)+(3)+(5)			
						DATA INVALID ⑤	179.0		
F463031	(180) ②	(10.5)	(120.33)	119.7	DATA INVALID ⑤			-	
F463033	30.2	10.0	59.7	119.7	99.90	159.9	159.9	62%	
F436034	8.1 ①	9.8	56.9	119.7	74.8	137.6	137.6	54	
F463035	8.4 ①	9.3	56.3	119.7	74.0	145.8	145.8	51	
F219521A	182.0 ②	10.0	56.6	119.7	248.6	311.7	311.7	80	
F471743	9.2 ①	11.3	54.4	119.7	74.9	140.2	140.2	53	
			56.8 (47%) (-53%)	119.7	114.4	179.0	179.0	64% (-36%)	

- NOTES:
- ① Tooling was in place from previous part.
 - ② Tooling was removed, and re-installed after machining other parts.
 - ③ Three-axis time, only, is reported. Five-axis time is code minutes, not re-programmed, is used for cutting periphery to size.
 - ④ Conservatively reported. Conventional running time is always higher than tape due to operator over-ride.
 - ⑤ NC machine ran slower than tape at 100%, needed repair. Also, programming not to guidelines.