

UNCLASSIFIED

AD NUMBER

ADB015629

LIMITATION CHANGES

TO:

Approved for public release; distribution is unlimited.

FROM:

Distribution authorized to U.S. Gov't. agencies only; Test and Evaluation; 30 JAN 1973. Other requests shall be referred to Air Force Avionics Lab., Wright-Patterson AFB, OH 45433.

AUTHORITY

AFAL ltr 17 Sep 1979

THIS PAGE IS UNCLASSIFIED

THIS REPORT HAS BEEN DELIMITED
AND CLEARED FOR PUBLIC RELEASE
UNDER DOD DIRECTIVE 5200.20 AND
NO RESTRICTIONS ARE IMPOSED UPON
ITS USE AND DISCLOSURE.

DISTRIBUTION STATEMENT A

APPROVED FOR PUBLIC RELEASE;
DISTRIBUTION UNLIMITED.

AFAL-TR-74-151

See 14120

ADB015629

DYNAMIC COLOR SCANNER SYSTEM

L. T. Hunkler

ITT Aerospace/Optical Division
Fort Wayne, Indiana 46803



DDC
RECEIVED
DEC 21 1976
AD

AD NO. _____
DDC FILE COPY

TECHNICAL REPORT AFAL-TR-74-151

MAY 1974

Distribution limited to U.S. Government agencies only; test and evaluation; 30 Jan. 1973. Other requests for this document must be referred to Air Force Avionics Laboratory (AFAL/RSP) WPAFB, Ohio 45433.

AIR FORCE AVIONICS LABORATORY
AIR FORCE SYSTEMS COMMAND
WRIGHT-PATTERSON AIR FORCE BASE, OHIO

*SLC
389042*

NOTICE

When Government drawings, specifications, or other data are used for any purpose other than in connection with a definitely related Government procurement operation, the United States Government thereby incurs no responsibility nor any obligation whatsoever; and the fact that the government may have formulated, furnished, or in any way supplied the said drawings, specifications, or other data, is not to be regarded by implication or otherwise as in any manner licensing the holder or any other person or corporation, or conveying any rights or permission to manufacture, use, or sell any patented invention that may in any way be related thereto.

Copies of this report should not be returned unless return is required by security considerations, contractual obligations, or notice on a specific document.

DYNAMIC COLOR SCANNER SYSTEM

L. T. Hunkler

ITT Aerospace/Optical Division ✓
Fort Wayne, Indiana 46803

TECHNICAL REPORT AFAL-TR-74-151

May 1974



Distribution limited to U.S. Government agencies only; test and evaluation; 30 Jan. 1973. Other requests for this document must be referred to Air Force Avionics Laboratory (AFAL/RSP) WPAFB, Ohio, 45433.

Air Force Avionics Laboratory
Air Force Systems Command
Wright-Patterson Air Force Base, Ohio

ADDITIONAL AIR	
NTIS	White Section <input type="checkbox"/>
TC	Dark Section <input checked="" type="checkbox"/>
USAM/OS/OPS	<input type="checkbox"/>
DISTRIBUTION	
BY	
DISTRIBUTION/AVAILABILITY CODES	
Dist.	APPROVAL AND/OR SPECIAL
B	

FOREWORD

This report describes the work performed by ITT Aerospace/Optical Division, a division of International Telephone and Telegraph Corporation, Fort Wayne, Indiana, under contract F33615-72-C-2071 for research and development of an experimental model color scanner embodying optical and electrical scanning techniques for the feasibility and applicability of such a device for determining exposure data for color film duplicates. This work was sponsored by and performed for the Air Force Avionics Laboratory Air Force Systems command, Wright-Patterson Air Force Base, Ohio, under project 6369AJ. The project engineer at Wright-Patterson Air Force Base was Mr. William A. Benz Jr.

The work reported herein was begun June 1972 and completed July 1974. The dynamic color scanner equipment was delivered, October 1973. Acceptance testing was completed in November of 1973 and a temperature compensation improvement to the circuitry was added in January 1974.

The ITT-A/OD project personnel who were assigned to the project are Messrs. T. Hunkler, R. Foote, J. Ringswald and Roger Thieme. This report was prepared and submitted by Mr. T. Hunkler May 1974.

This technical report has been reviewed and is approved.

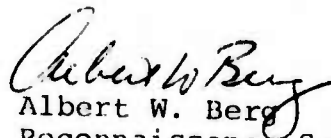

Albert W. Berg
Reconnaissance Sensor Development Branch
Reconnaissance & Surveillance Division
Air Force Avionics Laboratory

ABSTRACT

A three-aperture image dissector television tube is employed in a three-color photographic film densitometer. Equipment was assembled to accept reel film up to 9 inches in width, measure density, accumulate measurements and generate histograms describing the film density distribution. Sample size at the film plane is 94 microns with the number of samples per histogram variable to 10^6 . Each sample is classified as a density between 0.3 to 3.0 in 0.1 density increments. Histogram outputs are on oscillograph, paper tape and magnetic tape. Program details were reported in monthly and this final report as well as an equipment manual.

TABLE OF CONTENTS

		Page
1.0	PROGRAM OBJECTIVE -----	1
2.0	GENERAL DESCRIPTION -----	2
3.0	SYSTEM GOALS -----	5
4.0	SYSTEM REQUIREMENTS SUMMARY -----	6
5.0	SYSTEM RESULTS -----	7
6.0	DESCRIPTION OF EQUIPMENT -----	11
6.1	Film Transport and Controls -----	11
6.2	Scanner -----	17
6.2.1	Image Dissector -----	17
6.2.2	Spectral Filters -----	19
6.2.3	Film Sampling Geometry -----	19
6.3	Electronics -----	24
7.0	MAJOR PROBLEMS -----	29
8.0	OUTPUT FORMS -----	30

LIST OF ILLUSTRATIONS

	Page
Figure 1	Dynamic Color Scanner ----- 3
Figure 2	Pictorial View Dynamic Color Scanner Process--- 4
Figure 3	Output Density Vs. Known Input Density Curve--- 8
Figure 4	Output Density Vs. Input Density ----- 9
Figure 5	Output Density Vs. Input Density ----- 10
Figure 6	Film Transport Cabinet ----- 12
Figure 7	Processor Cabinet ----- 13
Figure 8	Cabinet Back Views ----- 14
Figure 9	Processor Cabinet Control Panel ----- 15
Figure 10	Film Transport Control Panel ----- 15
Figure 11	Scanner Geometrics ----- 18
Figure 12	Image Dissector ----- 20
Figure 13	Measured Photocathode Spectral Response ----- 21
Figure 14	Measured Filter Spectral Response ----- 22
Figure 15	Minimum Sampling Pattern, 127872/3 Inches ---- 23
Figure 16	Dynamic Color Scanner System ----- 25
Figure 17	Percent Signal Variation Versus Signal-to- Noise Ratio ----- 27
Figure 18	Film Density Versus Signal-to-Noise Ratio ----- 28
Figure 19	Typical Paper Tape Output ----- 31
Figure 20	Typical Oscillograph Output (Test Video Input)- 32
Figure 21	Magnetic Tape Organization ----- 33
Figure 22	Dynamic Color Scanner Tape Organization ----- 34

1.0 PROGRAM OBJECTIVE

The objective of this effort was to supply an experimental model color scanner embodying optical and electrical scanning techniques for the feasibility and applicability of such a device for determining exposure data for color film duplicates.

The system determines the range and magnitude of film densities in three colors at extremely high rates.

2.0 GENERAL DESCRIPTION

The Dynamic Color Scanner (DCS) contains a non-storage television camera, signal level threshold electronics, weighting accumulator counters and outputs in three histogram forms. The development nature of the problem, in representing unit film areas by color transmittance density histograms, required a versatile system. This versatility is in part noted if comparisons are made between the requirements and goal sections of this report. Film instantaneous sample diameter is 94 microns. Collections at rates of 1,022,975 samples per second were possible. This extreme rate is achieved by using a non-storage electronic scan camera containing a three channel image dissector. Rates of this magnitude require some form of data reduction prior to computer use and this is accomplished by an internal processor which in turn has a reduced output of 258 characters per 3 seconds. The system is pictured in Figure 1. Figure 2 is a pictorial view of the working system.

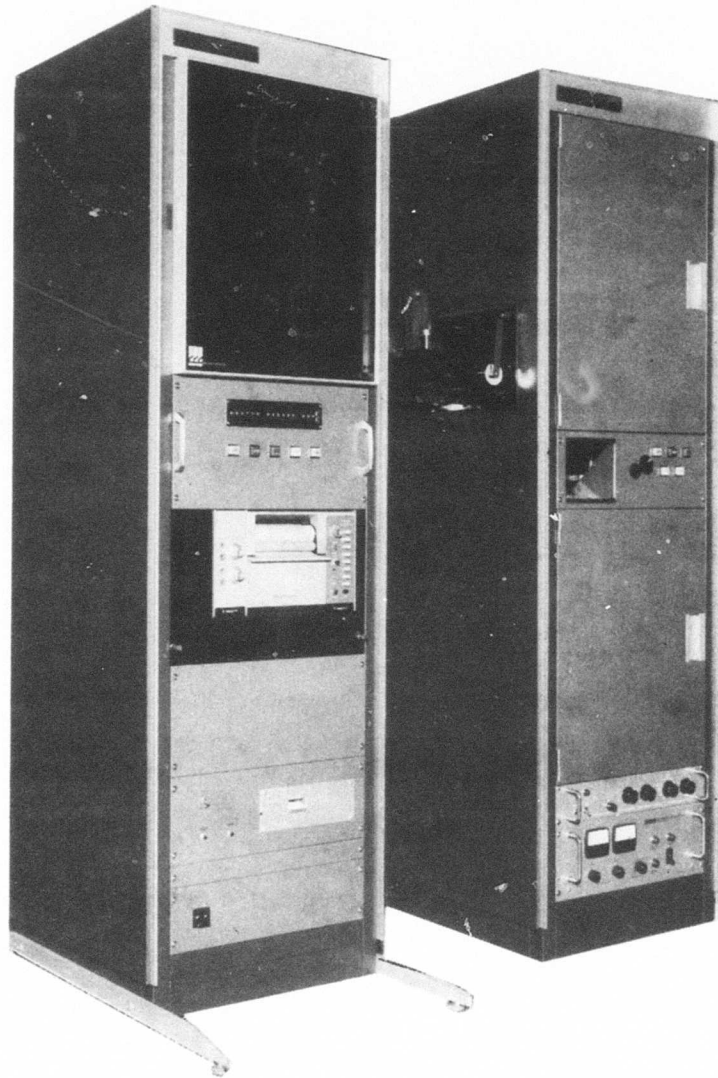

Figure 1 Dynamic Color Scanner

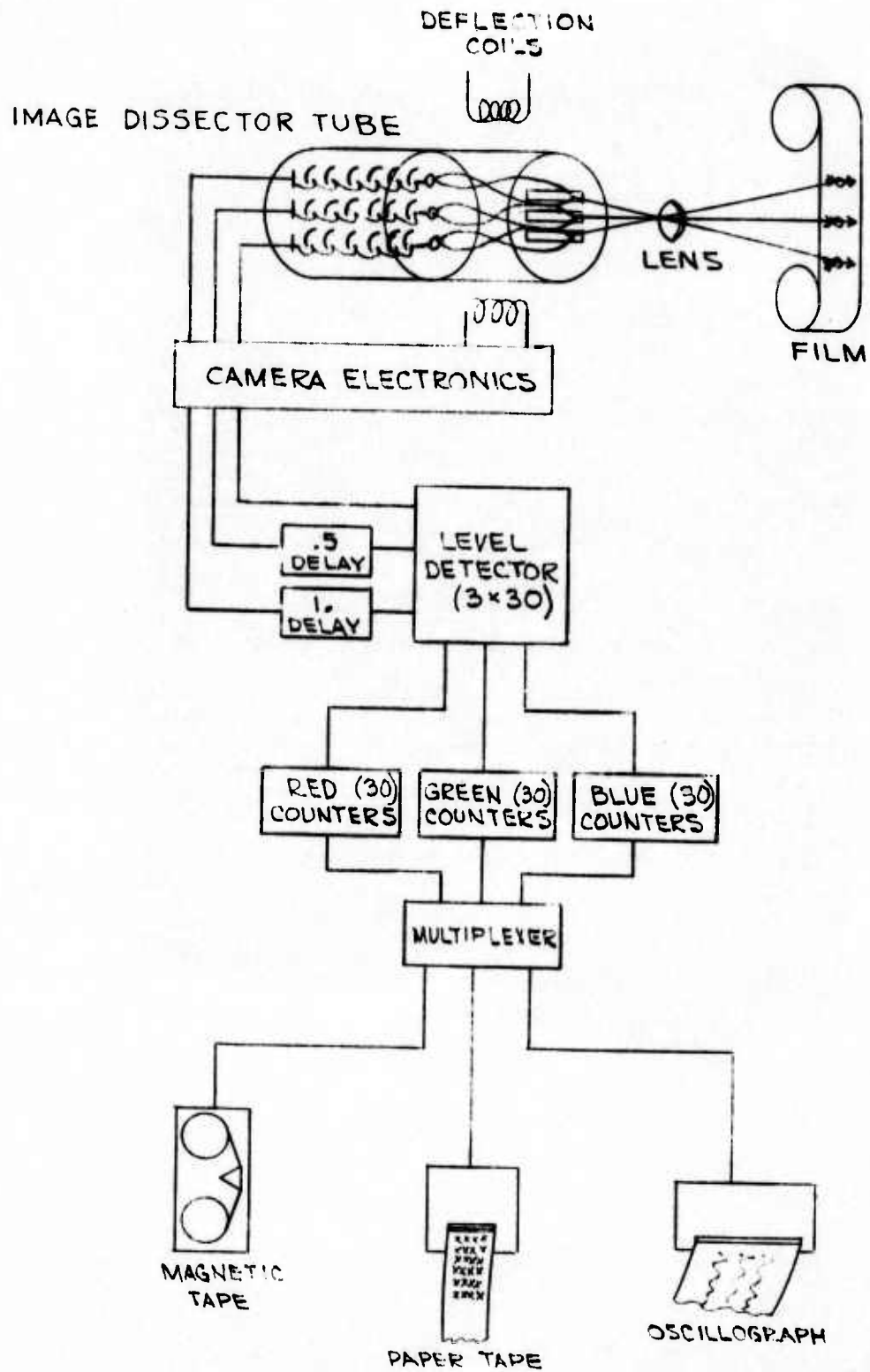

Figure 2 Pictorial View Dynamic Color Scanner Process

3.0 SYSTEM GOALS

The physical final scanning configuration for the DCS at this writing is unknown. Configuration depends on application. Basic requirements were for sampling every 0.050 inches. The DCS sampling may be extended to scanning every 0.0037 inches in both planes of the objective with miniature switch settings. A corresponding change in integration time (bandwidth) to match the total sample/record is available through miniature switches in the electronics. Continuous scanning and bandwidth variations were considered goals, for they require high speed operations at sample rates of 2.6×10^{-6} seconds and line rates of 296 lines/second.

A second goal was in the area of dynamic range. Desired range was an extension to 4.0 density from 3.0. The additional range was not attempted because of low signal-to-noise ratios at low signals.

It became apparent during circuit design that the three color data outputs should represent a corresponding film area. As the dissector samples a target it actually observes three separate and different areas within a particular sample time. The three samples are displaced in the vertical direction (direction of film motion) by 0.3 inches and separate electronics data gathering delays were added to insure correlated histogram outputs indicating a particular film area. A fourth addition was included in the number of significant bits outputted from the accumulators located in the internal processor. Each of the 84 accumulators has the ability to store 1,048,576 (20 binary bits) counts. The count is divided by 1024, and limited to 999 (10 bits) at the output. As outputting occurs only the ten most significant bits are transferred to give a maximum count of 999 (1024 rounded to three decimal characters). A thumbwheel switch permits up to the 15 most significant bits to be outputted. This in effect multiplies the range of system use by 64. Without multiplication unit digit (001 decimal) indicates 1024 counts occurred. A 999 decimal indicates at least (999 X 1024) 1,022,975 counts of a particular density level occurred.

Power rewind for the film spools was also added.

4.0 SYSTEM REQUIREMENTS SUMMARY

- Transport film at a speed of 5 feet per minute while scanning.
- Accept thin base roll film in 70 mm, 5-inch and 9-1/2-inch widths and lengths up to 500 feet. Thin base from 0.0020 inches to 0.0040 inches are considered necessary.
- Measure red, green and blue integral transmission densities over the range of 0.3 to 3.0.
- Provide output in the form of a density histogram for each color.
- Acceptable film spool diameter shall be 10 inches maximum. The spool type is specified by MIL-STD-26565.
- The film sample areas are to be within 0.05 inches of adjacent samples.
- When scanning 9-1/2 inch film, the center 4-1/4 inches will be scanned.
- The system will function using SO-242 and SO-360 film type.
- System data output is via 9-track digital magnetic tape, IBM compatible format.
- The output indicates the density histogram for each of three colors for each three inch film lengths. Density increments are every 0.1 from 0.3 to 3.0.
- System data output is also via an analog strip recorder.
- The histograms are relatable to ANSI defined diffused density and will correlate with standard color densities.

5.0 SYSTEM RESULTS

Acceptance tests were performed the week of 29 October 1973 at the customers facility. All requirements were met.

Calibration of output density versus input for known neutral (ND) and color density were made on three separate occasions. Figures 3, 4, and 5 show the results. Response to green is linear to both ND and green input film. Red response is good for ND inputs and deviates for red film input while blue response is good for blue film and deviates from linear for ND. The exact reason for these non-linearities are not known at this writing. It is known that the sensor is linear, as is the electronics following the sensor and any electrical adjustments to linearize to ND will result in non-linearity in color.

Differences in film point measurements could contribute to some nonlinearity. Known input densities used for testing were obtained using a MacBeth TDA 1000 Densitometer with interference filters of 440, 550 and 668 nanometers. The test film was measured by the TDA 1000 at twelve points over each 3 inch area increment. Measurements were on the three points on the width by four along the film length. The known density was taken as the average of these twelve measurements.

DCS measurements were made at 1152 points across the film width by 111 points on the film length (127,872 points).

Remaining causes are the optics and measurements techniques. The non-linearity should not cause problems since it can be removed from the output data mathematically.

Channel to channel crosstalk remains a problem and could account for some nonlinearity. A technique of cross channel signal subtraction was designed into the sensor preamplifier and adjusted for less than 1% crosstalk using white light as an input. It is possible this technique is not suitable and a better approach may be to reduce the cause; electron mixing in the sensor election multipliers. This may be accomplished by insertion of baffels in the multiplier.

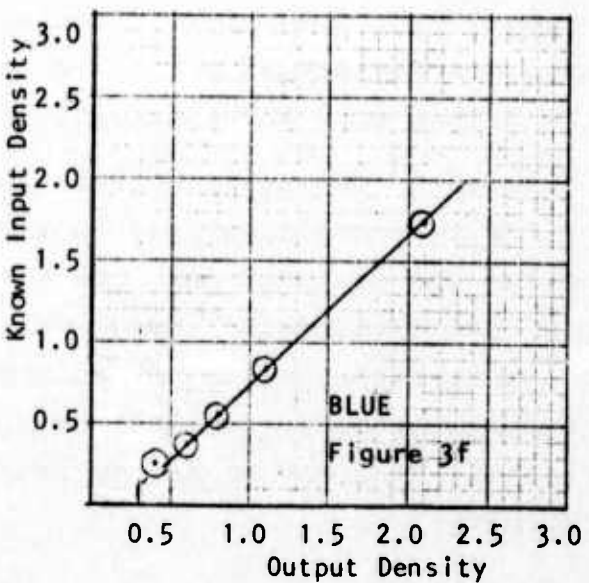
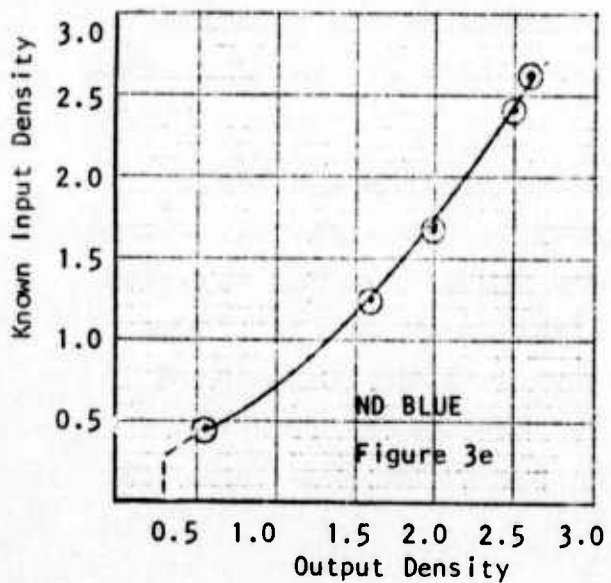
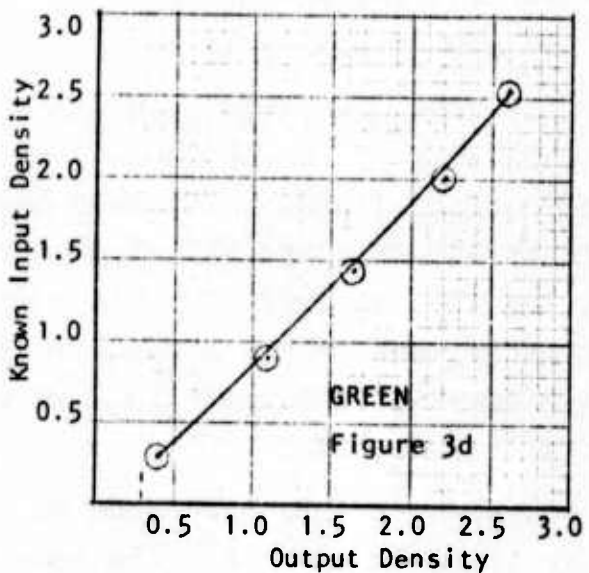
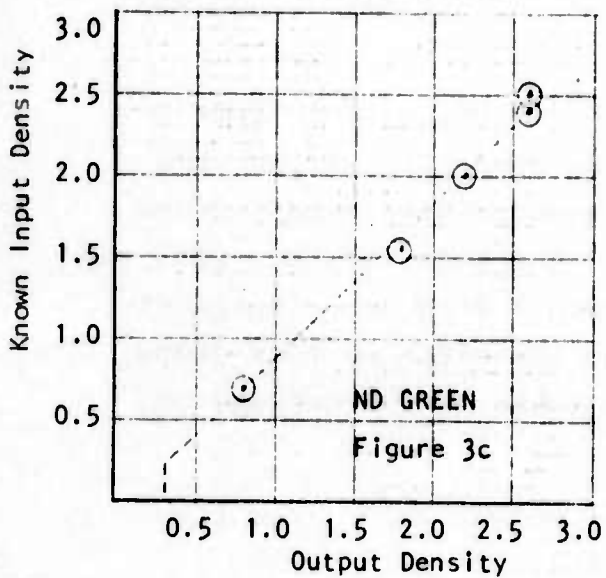
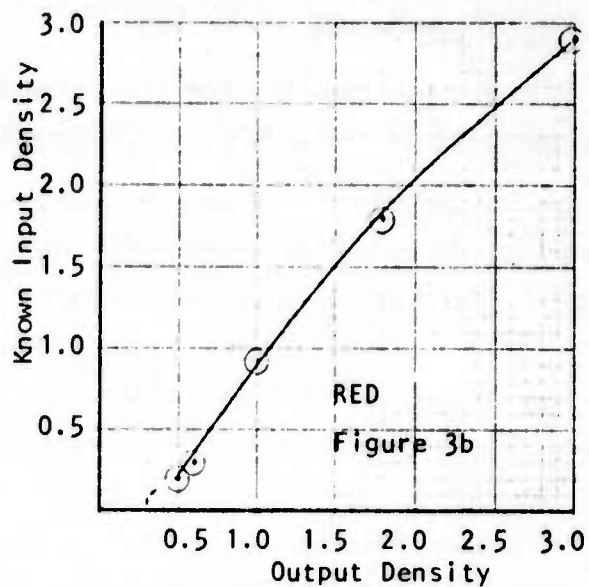
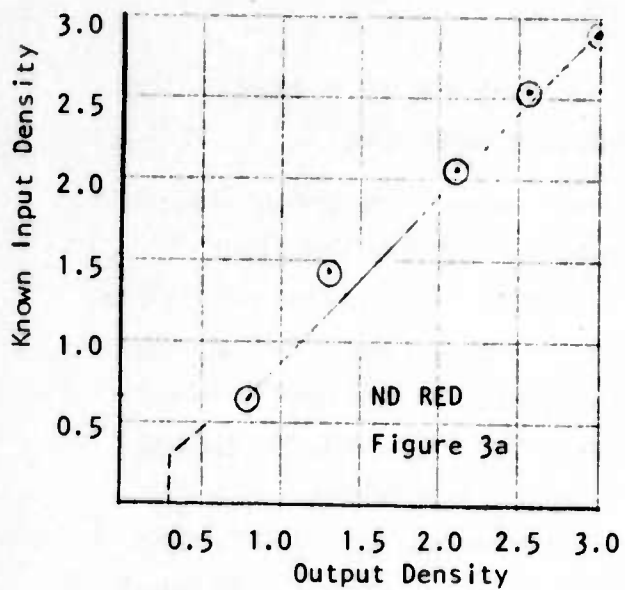

Figure 3

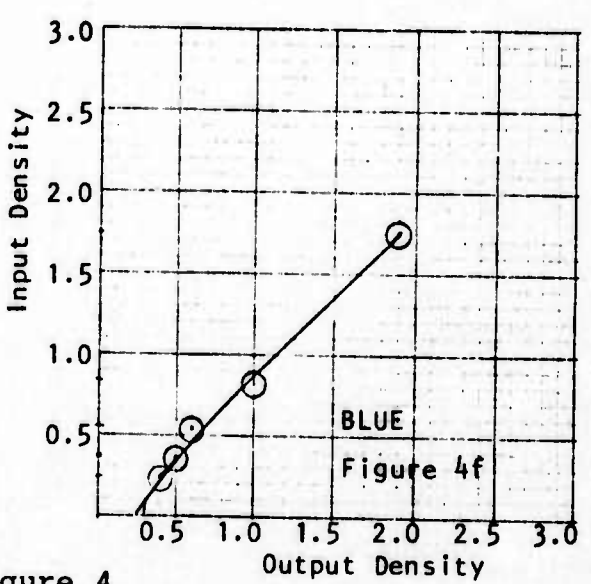
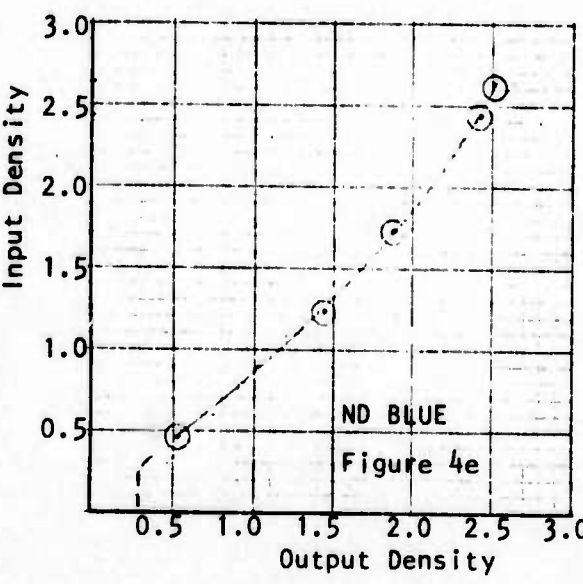
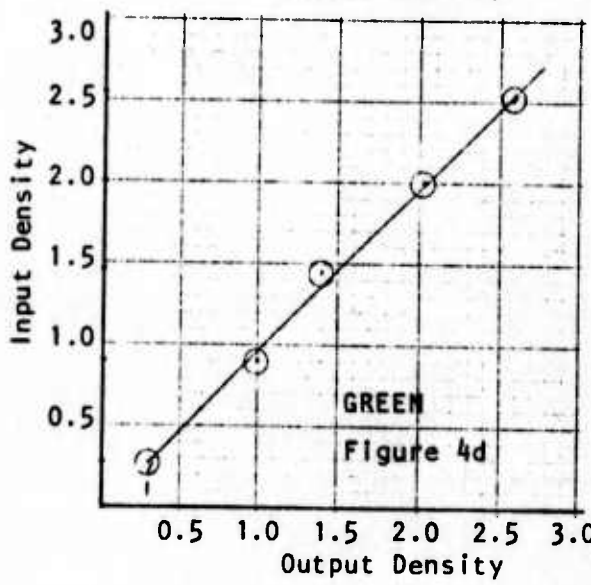
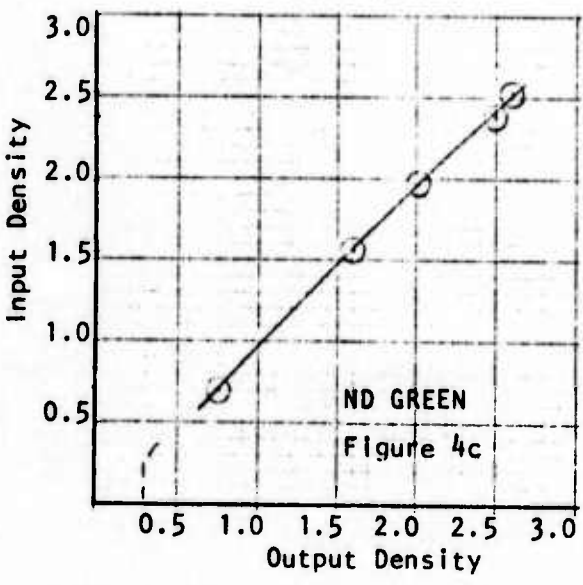
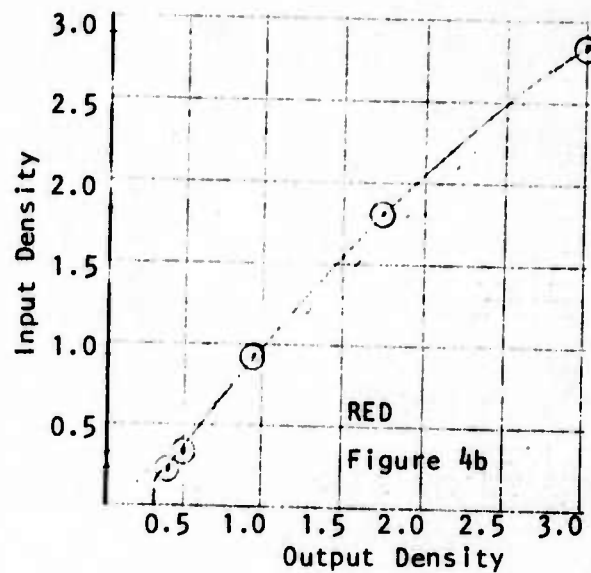
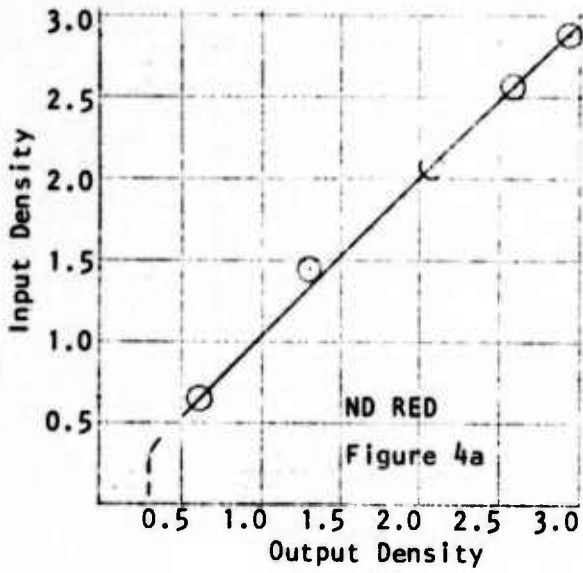

Figure 4

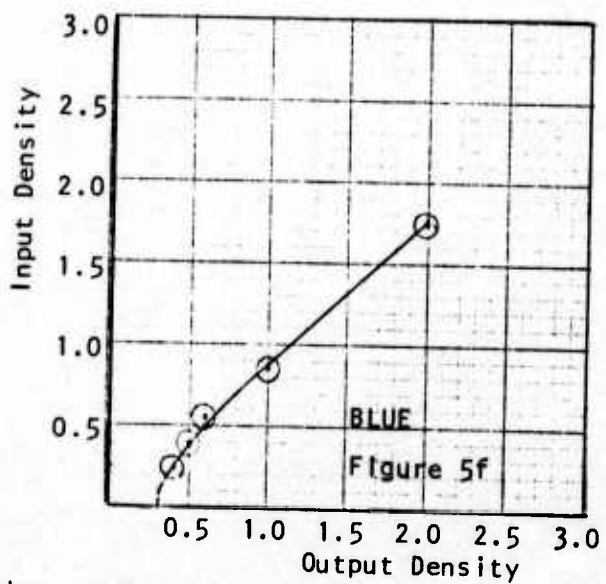
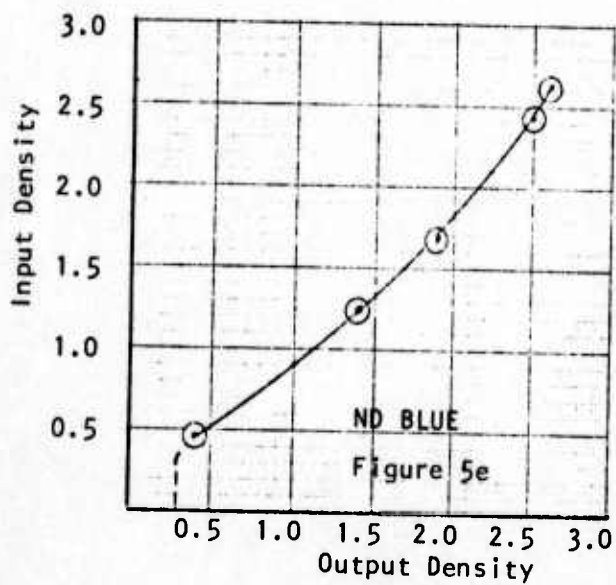
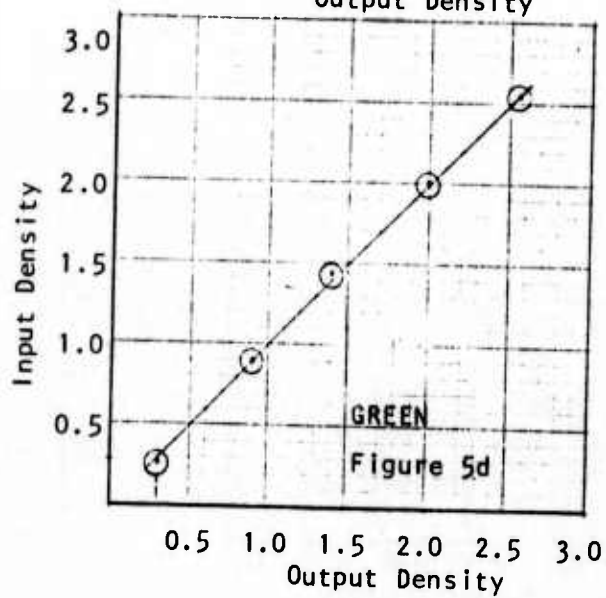
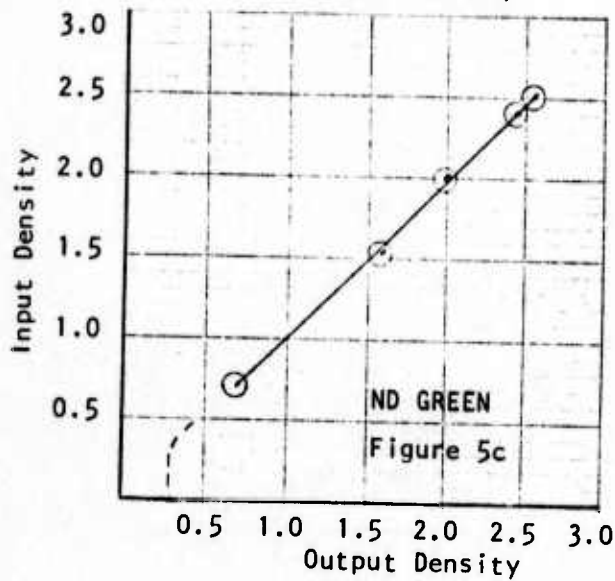
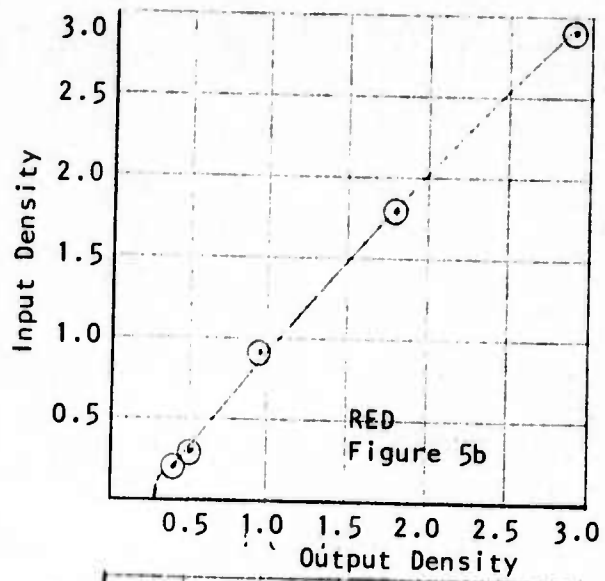
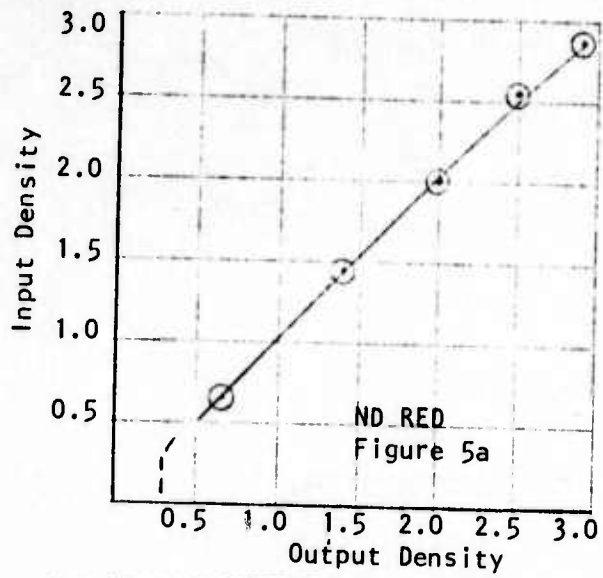

Figure 5

6.0 DESCRIPTION OF EQUIPMENT (See Figures 6, 7, and 8)

The Dynamic Color Scanner (ITT 8008554) consists of two 24 x 27 x 67 inch equipment cabinets; Film Transport Cabinet and Processor Cabinet. Spool mounts extend outside the film transport cabinet to make the overall width 43 inches. Estimated weight is 300 pounds each and input power required to the processor cabinet is 115 volts 60 Hz, single phase, 5 amperes. The Film Transport Cabinet input power is 115 Volts 60 Hz, single phase 20 amperes.

Dynamic Color Scanner operation is divided into three major functions; Film Transport and Controls, Scanner and Electronics.

6.1 Film Transport and Controls

Film widths of up to 9-1/2 inches may be processed through the DCS. The full film spool is placed on the left and take up spool to the right. Film is threaded off the spool, under the first roller, between each of the next two pair, and around the takeup spool. All rollers are chromed for minimum film marking. The drive roller is powered by a stepping motor. Two additional DC motors for film take-up and film rewind are located adjacent to the film spools. Electrically driven clutch assemblies work in conjunction with the DC motors to maintain constant film tension as it passes through the objective plane of the scanner lens and during rewind a take-up clutch applies film tension while the rewind motor is fully on. Tension feedback control is provided from a lamp/photoresistor at the end of rollers. The resulting error signal is amplified and drives the take-up clutch.

A switch is provided for film threading FORWARD, for film rewinding REWIND, for no drive STOP, and for normal film scanning RUN.

The following controls operate the DCS: (See Figures 9 and 10).

Processor Main Power, located in the bottom front panel of the processor cabinet applies power to the processor cabinet only.

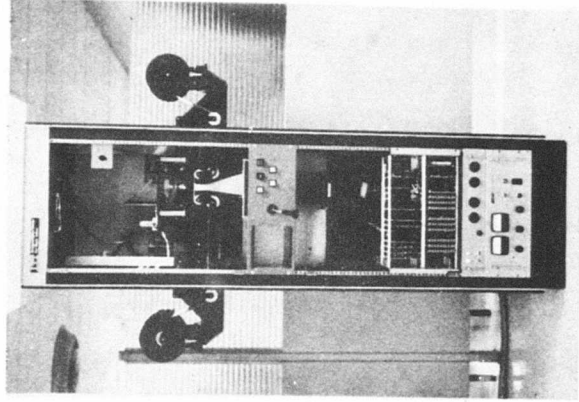
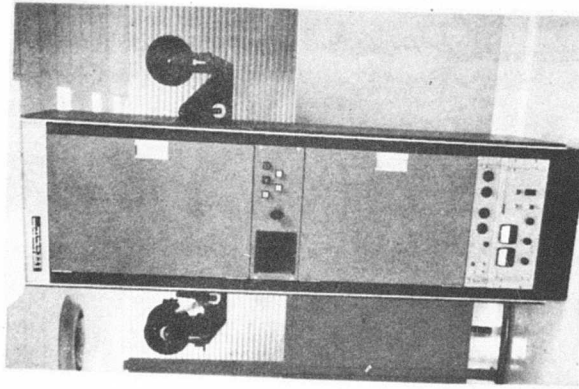
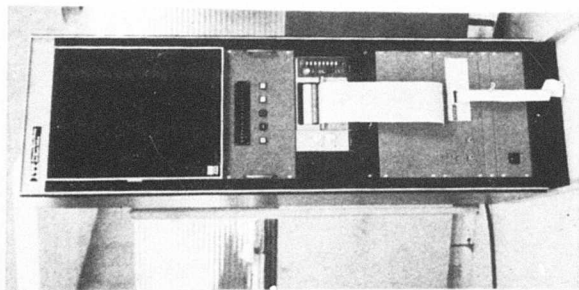
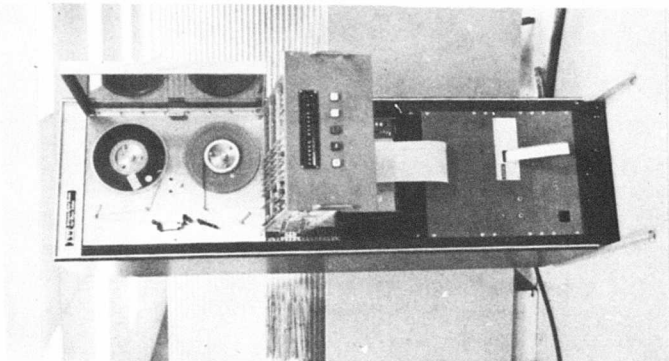

Figure 6 Film Transport Cabinet



Front View



Open Front View

Figure 7 Processor Cabinet

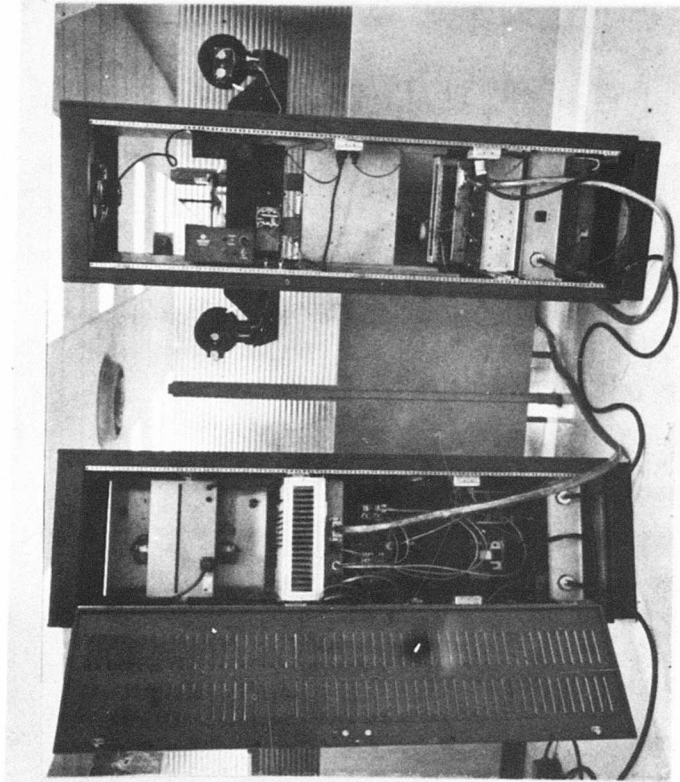

Film Transport Processor

Figure 8 Cabinet Back Views

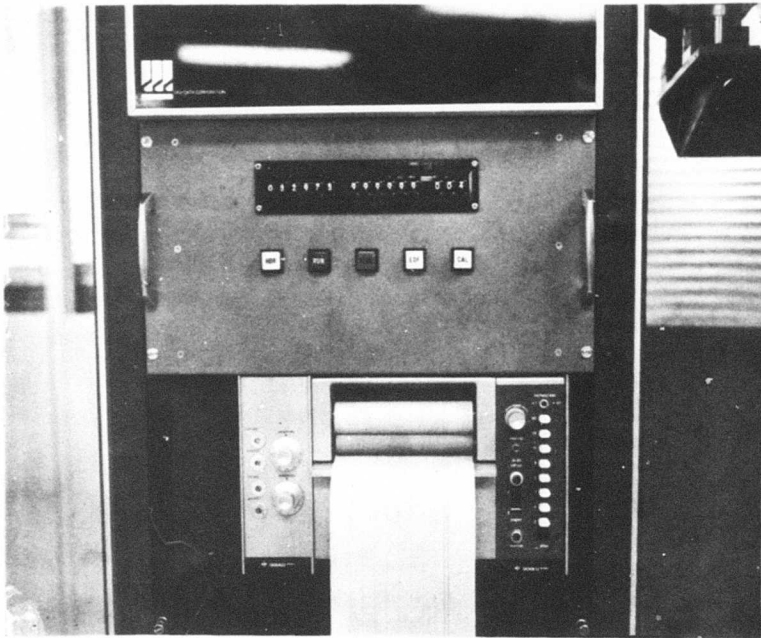

Figure 9 Processor Cabinet Control Panel

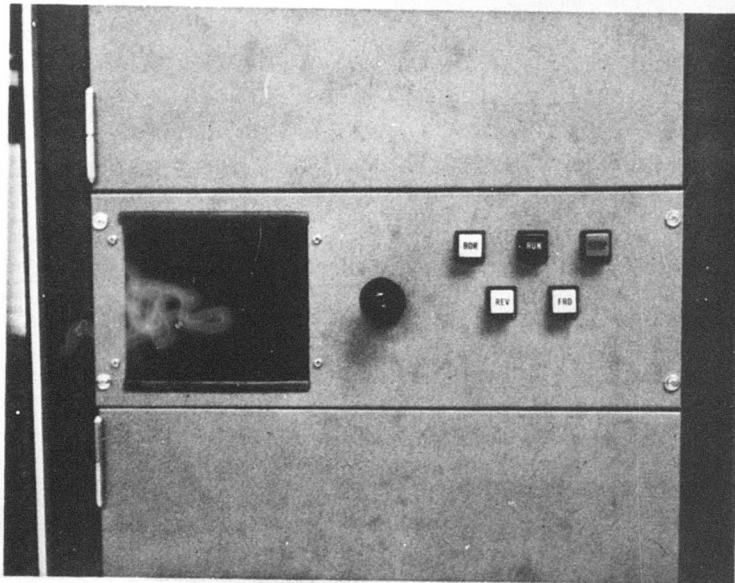

Figure 10 Film Transport Control Panel

Film Main Power, located inside rear of Film Transport Cabinet, applies power to this cabinet only.

Manual Start push switch on paper tape printer, pushing initiates the printout of the next 3 seconds of data.

A Manual Start following a HDR Command results in header data only recording.

Auto/Manual toggle switch on paper tape printer - in Auto, paper tape runs continuously printing out approximately every 17th data record. In Manual position, only the next data record is printed after a start print command.

BDR, (Border Indication) Pressing will inhibit data to the accumulators. This control is provided as a means of eliminating certain extreme density conditions in the film. The fact that it has been actuated within the data record is indicated by a 1 for the fourth character of the data record.

RUN, Pressing the RUN switch will initiate scanning and recording with the next 3 second time mark.

STOP, Pressing the STOP switch will inhibit scanning and recording, coincident with the next 3 second time mark.

REV, causes instant reversal of the film motion, any time.

FRD, causes instant forward film motion, any time.

HDR (Header) Enables the 15 digits indicated by thumbwheel switches to be outputted.

EOF (End of File) Enables an EOF in the magnetic tape recorder.

CAL (Calibrate) Enables continuous data output numbers of 999.

6.2 Scanner

The scanner is basically an image dissector television type image tube which is the heart of the Dynamic Color Scanner.

The scanner (see Figure 11) is located below the film drive system and consists of a three aperture image dissector tube with focus and deflection coils. Below the scanner is a dual high voltage power supply used only by the image dissector.

During normal scanner operation, the three apertures of the image dissector are effectively magnetically deflected at right angles to film travel, up to 296 times per second. The aperture diameter is 0.0015 inch at the tube photocathode and 0.0037 inch at the film plane. Apertures are located 90 diameters apart on a line parallel with film travel. Spectral filters centered at 440 nm, 550 nm and 668 nm are placed near the image plane on the dissector photocathode. Usable scan length on the dissector photocathode is 1.75 inches. This corresponds to 4.25 inches at the film plane. A switch is supplied which decreases scan amplitude in the dissector to accommodate 70 mm film width, approximately 1 inch at the photocathode.

6.2.1 Image Dissector

The image dissector is a special electronic deflectable photomultiplier. Inside its evacuated glass envelope is a photocathode, accelerating mesh, aperture plate and electron multiplier.

With a field of view imaged on the photocathode surface by a lens system, electrons are emitted from the photocathode surface. For the image dissector the number of electrons emitted is directly proportional to the light level. These image-electrons are accelerated toward a mesh held at a positive potential with respect to the photocathode. Approximately half pass through the mesh into an electrostatic field-free space (or drift tube) and are magnetically focused at a plane containing an aperture. Without deflection of the electron image, only those electrons from a small photocathode area at the image center would pass through the aperture. Horizontal and/or vertical magnetic fields are, therefore, required to deflect the desired electron image in an orderly manner across the aperture.

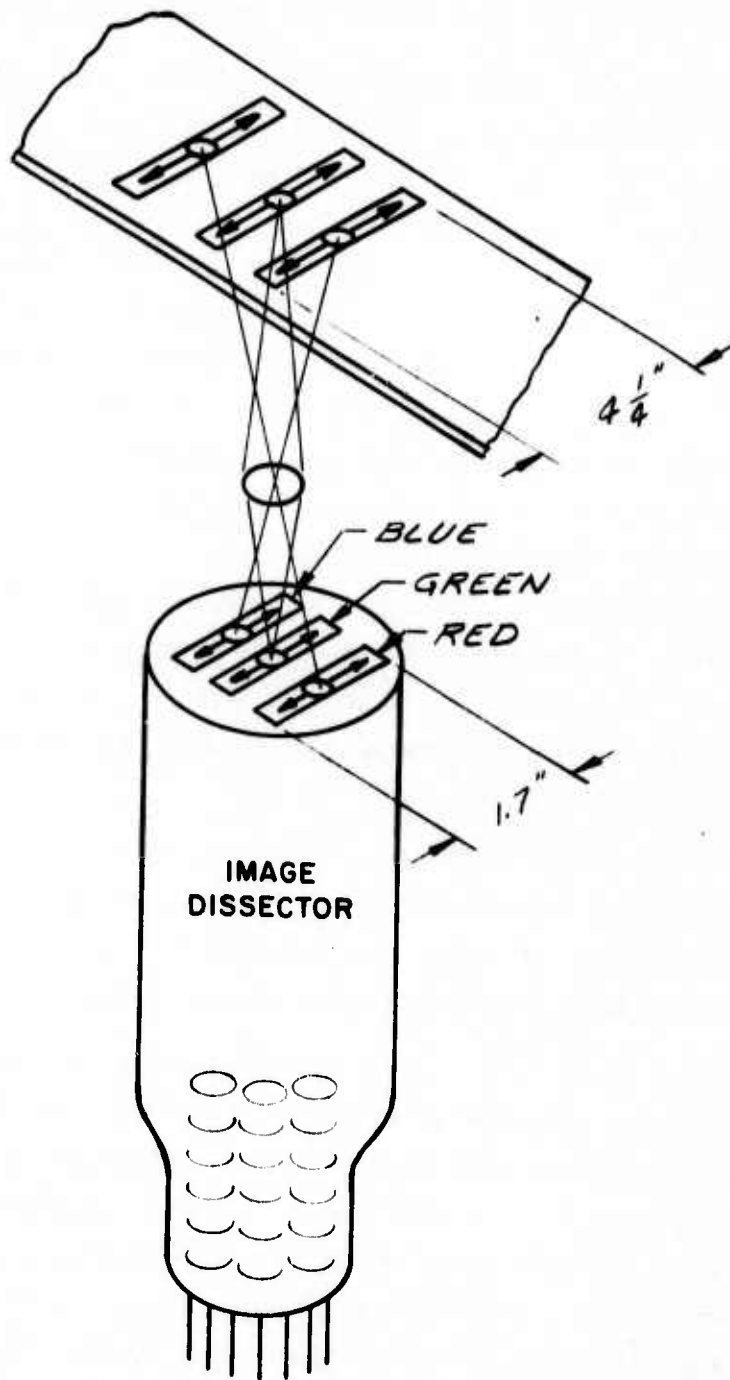

Figure 11 Scanner Geometrics

The standard single aperture Vidisector[®] elements are shown in Figure 12. Multiple aperture/electron multiplier assemblies can be produced. Such a device, designated F4052, is used by the DCS. It contains three defining apertures, backed by three electron multipliers. A fiber optic face plate permits close coupling of the external strip filters to the photocathode inside the envelope. Photocathode potential is -2600 volts DC and accelerating mesh potential is -2000 volts DC. The electron multiplier operates from approximately -200 volts per stage. Various photocathode spectral responses are available. The particular response desired and used in the Dynamic Color Scanner is shown in Figure 13.

6.2.2 Spectral Filters

Three filters are placed on high quality optical glass in strips 1.80 long x 0.125 ± 0.005 inches wide. Peak wavelength are 440, 550 and 668 nanometers and spectral bandwidth at half peak is 20 nanometers ± 2 nanometers. Blocking of the unwanted energy between 200 to 850 nanometers is to a level less than 0.01% of peak transmitted wavelength. Figure 14 is the measured filter response. Filters are easily changed by removing the lens assembly.

6.2.3 Film Sampling Geometry

Line rate is variable from 296 to 18.5 lines per inch film length. Rates are set internally. Using a smooth ramp deflection, 1152 film samples per line will be measured however fewer points may be achieved by disconnecting the least significant bits to the D-to-A converter, generating the smooth ramp.

Requirements to sample at dimensional intervals of less than 0.050 inches are met at 37 lines per inch (every 0.027 inches) and 1152 per line (every 0.0037 inches). There are, at this rate, 127872 samples per 3 film inches, measured in three spectrums and recorded in 84 three digit numbers (see Figure 15).

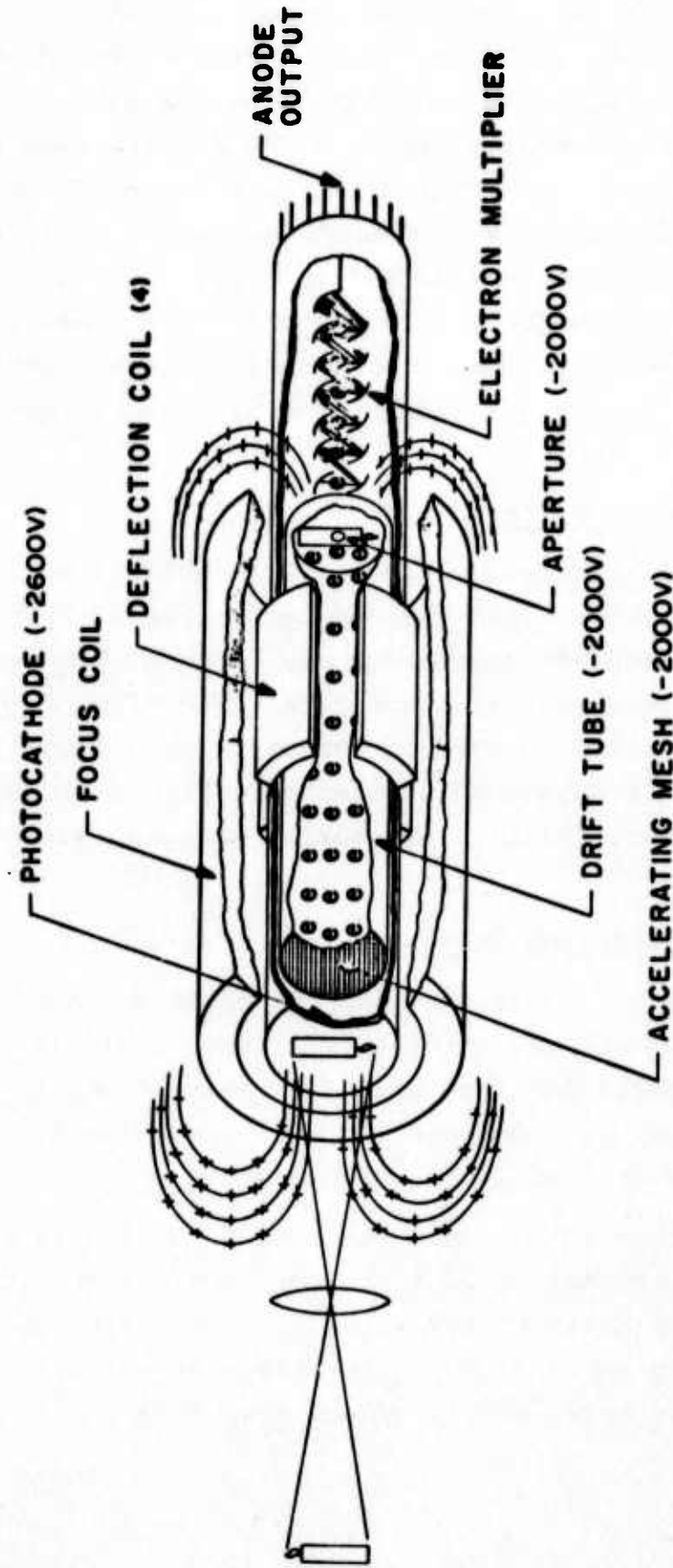

Figure 12 Image Dissector

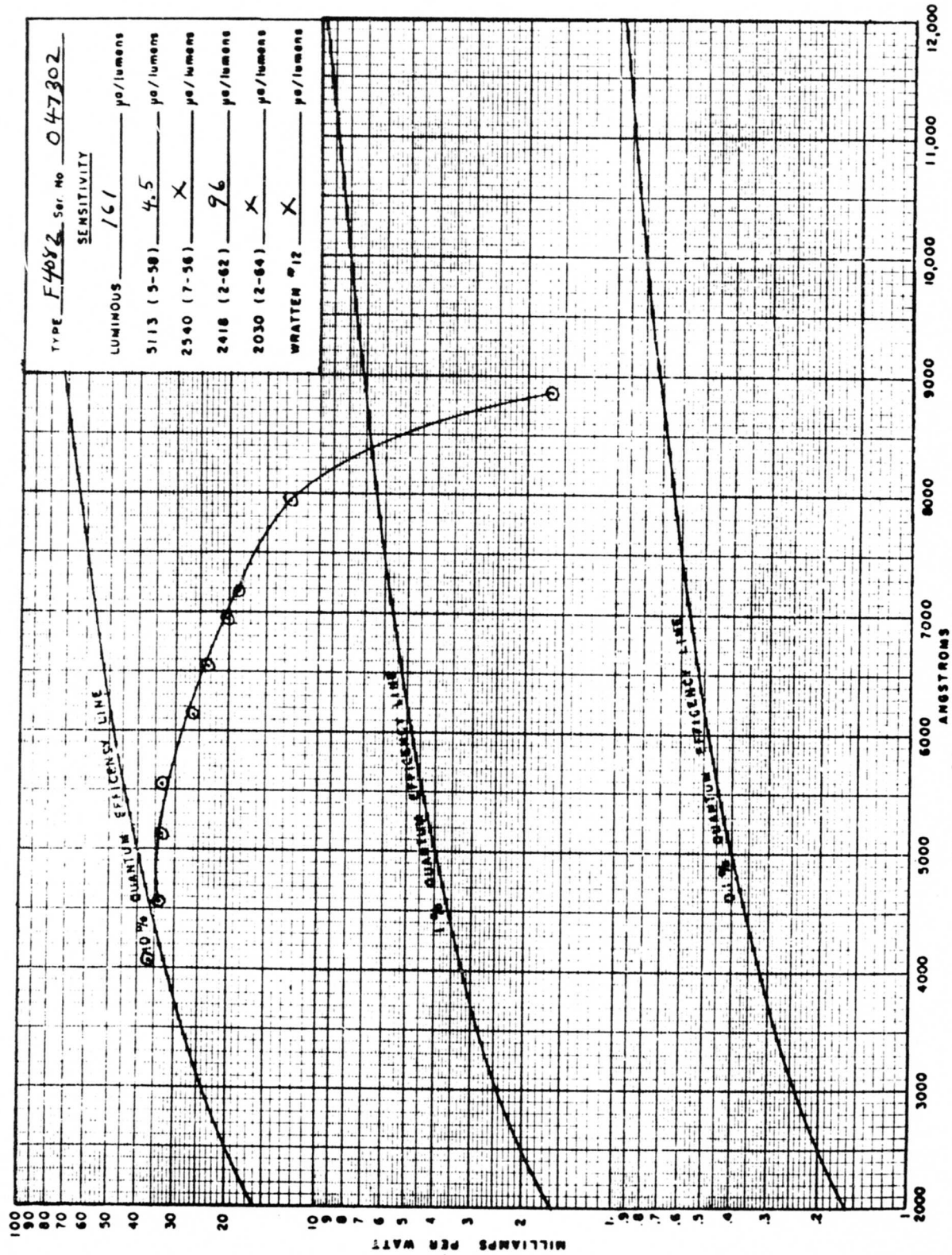

Figure 13 Measured Photocathode Spectral Response

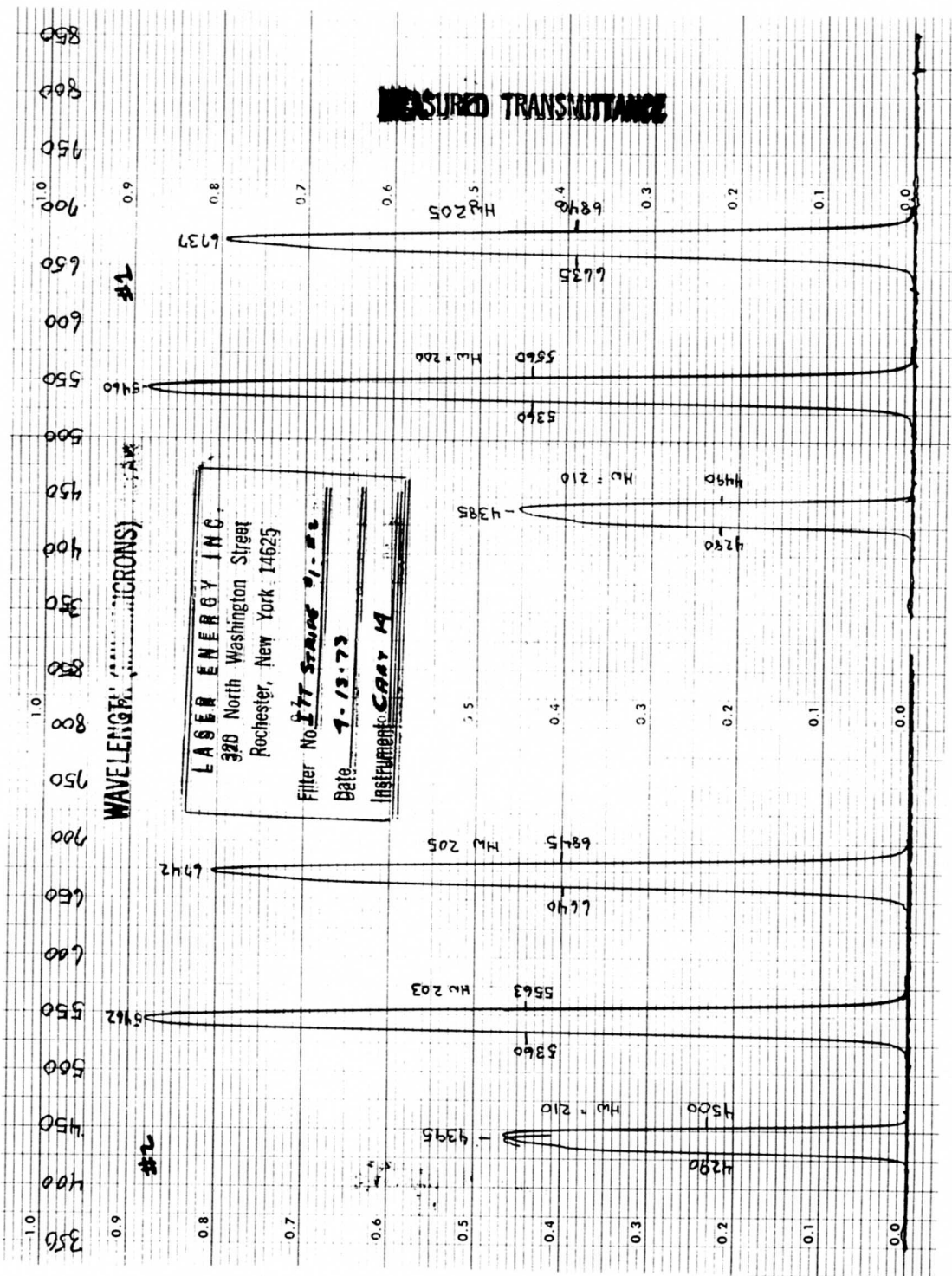

Figure 14 Measured Filter Spectral Response

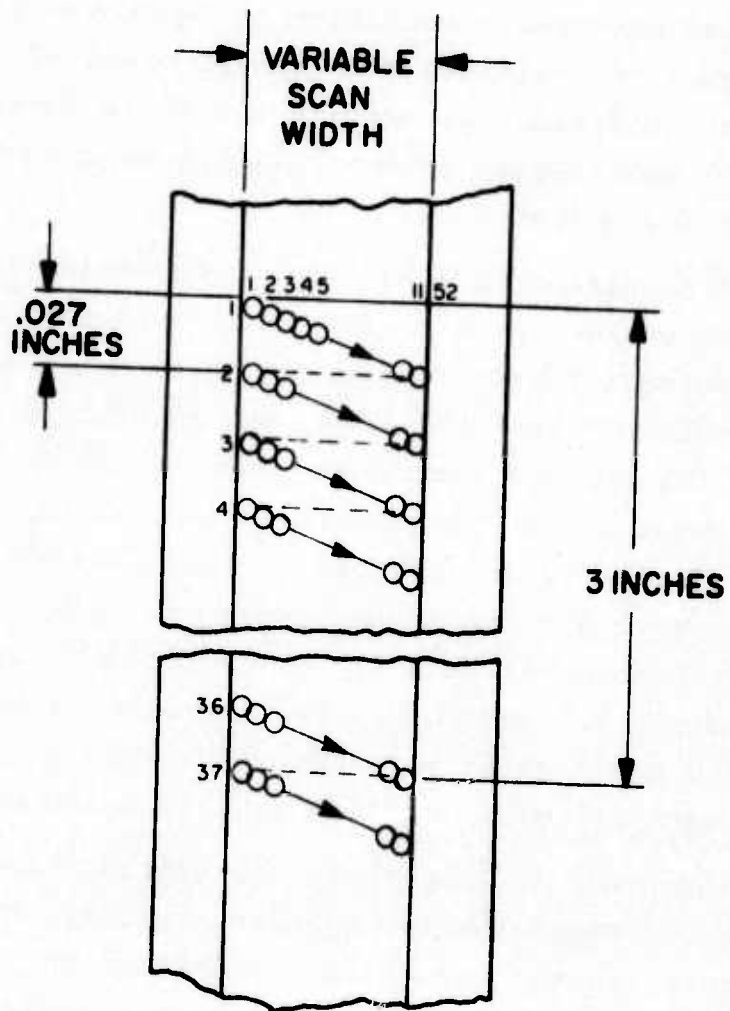

Figure 15 Minimum Sampling Pattern, $127872/3$ inches

6.3 Electronics

Detailed electronic operation is described in the Equipment Manual. Figure 16 indicates the general areas of signal handling to be; signal conditioning, density threshold detectors, counters and a 90 to 1 multiplexer switch. Timing synchronizes film motion, scan and output data.

Signal condition is achieved by converting the dissector output signal current of 0 to 400 μA to 0 to 10 volts peak and gating the voltage level representing film area transmission to voltage threshold detectors. Only one threshold detector is permitted "ON" for any one sample and each threshold detector drives a separate counter. At the end of an area sampling period, 3 seconds, the quantity accumulated by each counter is transferred to output storage and the accumulators are reset and continue counting. Outputting of data is accomplished by the 90 to 1 switch in approximately 1.7 seconds, a time determined by the input rate acceptable to the digital tape recorder. This sequence is repeated for each 3 inch increment of film density measurement.

The exercise of determining measurement accuracies involves relating photocathode loading aperture current, signal volts and signal-to-noise ratios to a normal distribution curve. Each channel circuit gain is set for 10 volts peak signals (0.3 density) with resistors in a current-to-voltage, operational amplifier configuration in the preamplifier. The resistor values indicated peak anode currents of 377, 307 and 142 microamperes for the red, green and blue channels respectively. Multiplier gains in the tube are $(4.18)^{10}$, $(4.48)^{10}$ and $(4.5)^{10}$ for the respective channels. Aperture currents causing the peak anode currents are therefore 2.31×10^{-10} , 0.94×10^{-10} and 0.417×10^{-10} amperes, respectively.

Signal-to-noise ratios are a function of aperture current, gain, sampling time and the electronic change of an electron. The number under the radical turns out to be electron events occurring during the sample interval. For the red channel the S/N ratio is:

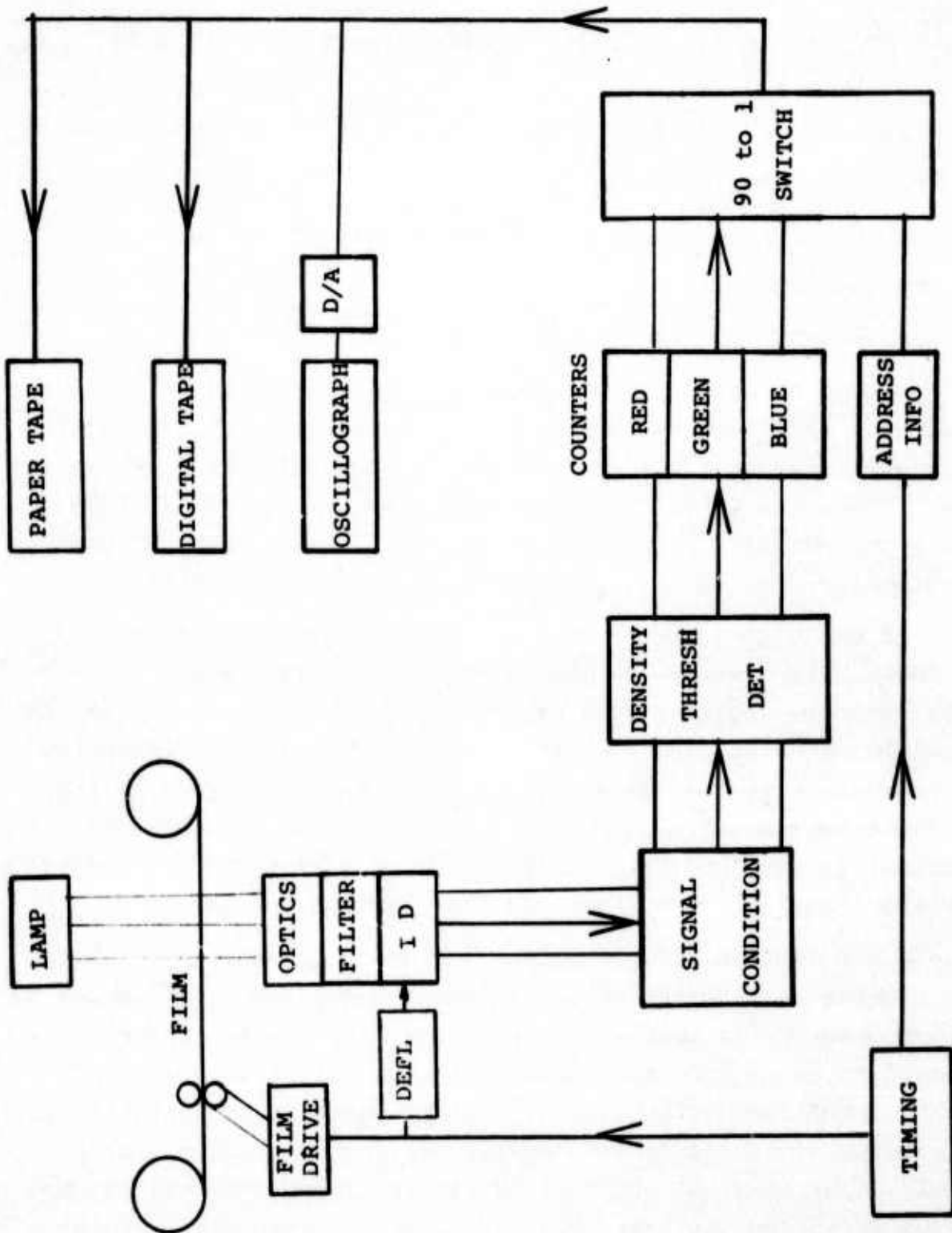

Figure 16 Dynamic Color Scanner System

$$\begin{aligned}
 S/N &= \sqrt{I_{Aper} \frac{G-1}{G} \times \frac{\text{time}}{e}} \\
 &= \sqrt{I_{Aper}} \sqrt{\frac{4.5-1}{4.5} \times \frac{21 \times 10^{-6}}{1.6 \times 10^{-19}}} = 10.10 \times 10^{-6} \sqrt{I_{Aper}}
 \end{aligned}$$

$$\text{Red S/N} = 10.10 \times 10^6 \sqrt{2.31 \times 10^{-10}} = 153 \quad (\text{ratio})$$

For the green channel;

$$\text{Green S/N} = 10.10 \times 10^6 \sqrt{0.94 \times 10^{-10}} = 98$$

For the blue channel;

$$\text{Blue S/N} = 10.10 \times 10^6 \sqrt{0.417 \times 10^{-10}} = 65$$

The question of density measurement accuracies is related to S/N ratios and since $S/N = S \pm 3/S$, for $\pm 3 \sigma$ deviation, then for the red channel the peak S/N for 153 yields a signal with 1.96% variation. Since the level threshold detectors are set for $\pm 11.4\%$ window increments virtually no error should exist for the peak red signals. For the 65 blue S/N we have the signal 4.6%.

As the signal levels decrease due to more dense film, the S/N ratio decreases by the square root. At a level where the S/N ratio is ≈ 26 , signal variations due to noise is equal to the level threshold detector window width of $\pm 11.4\%$. Figure 17 indicates the expected error versus signal-to-noise ratio. Figure 18 indicates the relationship of S/N to density for all channels. It is important to note that Figure 18 is for only 21×10^{-6} seconds of sampling time. Changing the scan rate changes sample time.

A second item affects noise-in-signal, channel crosstalk. This problem is inherent in the existing F4052 and is minimized by optimum location of apertures with respect to the three first-dynodes. Tubes to date have measured crosstalk of 5 to 20% and this has been reduced to less than 1% by subtractive circuitry in the preamplifier. Since the desired use for the DCS is over a dynamic input range of 500 to 1 (0.2%) it is expected the 1% correction is not sufficient. The effect of 1% crosstalk is to be investigated.

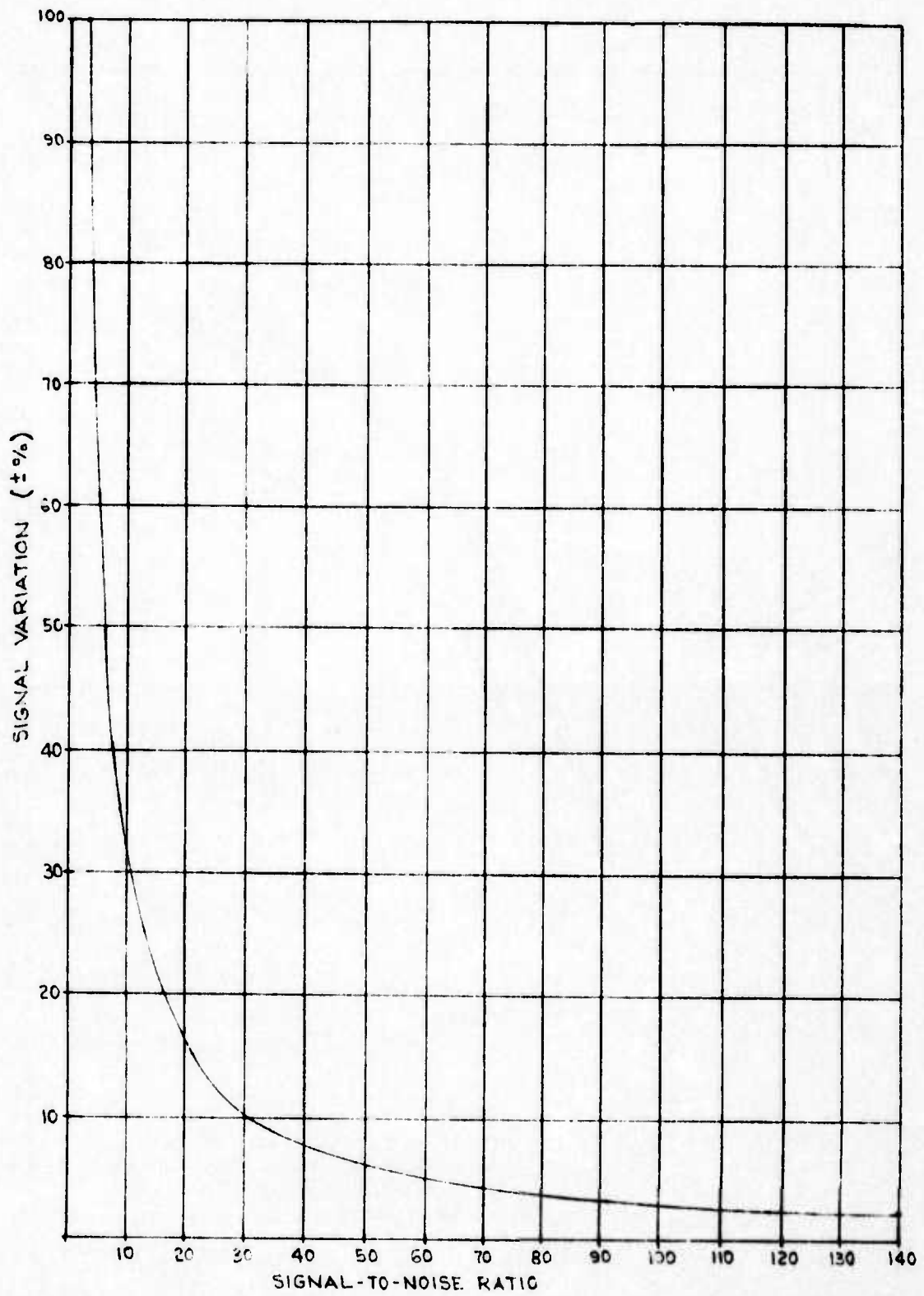

Figure 17 Percent Signal Variation Versus Signal-to-Noise Ratio

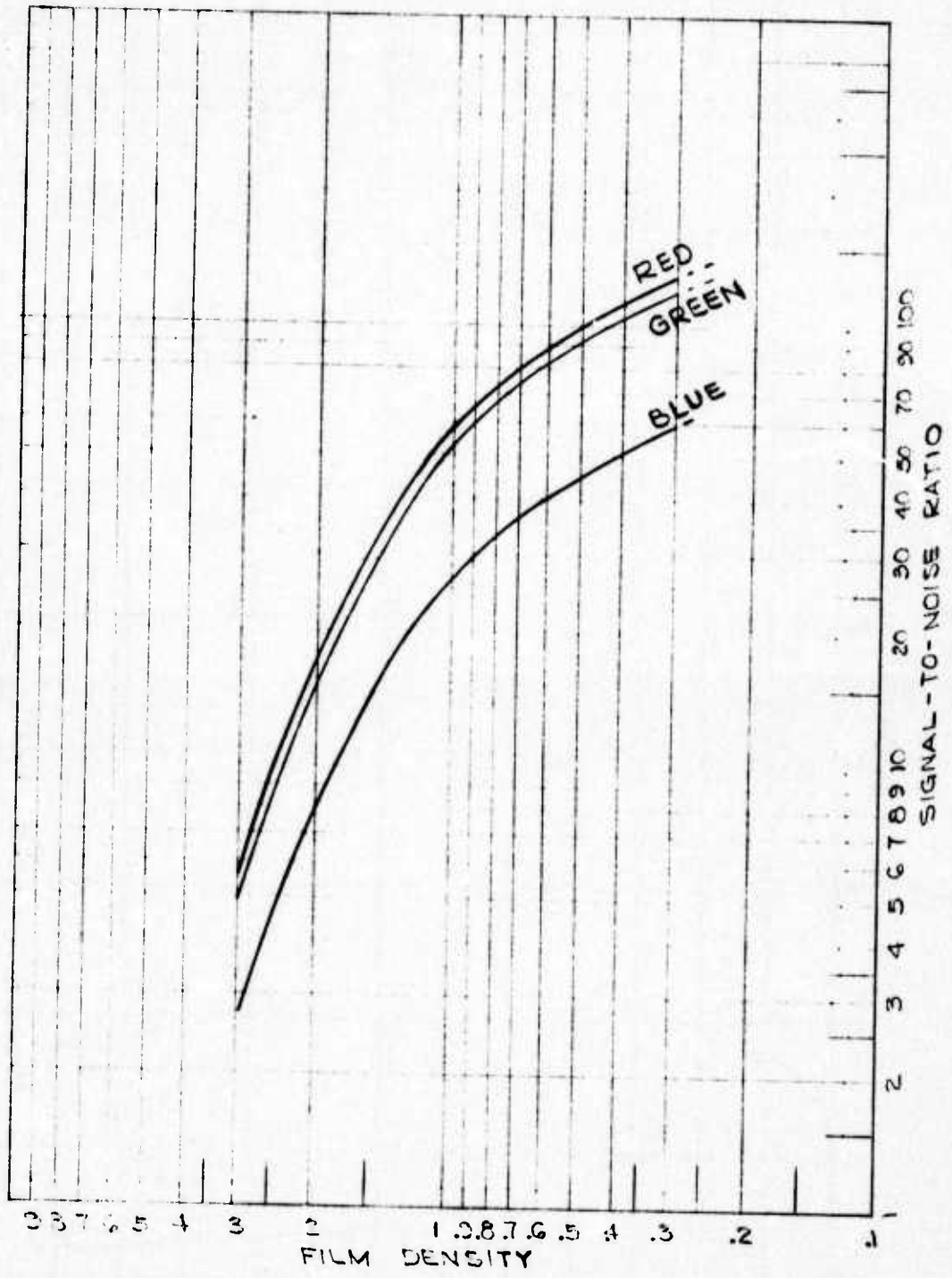

Figure 18 Film Density Versus Signal-to-Noise Ratio

7.0 MAJOR PROBLEMS

Two major problems have occurred in the development of the DCS, tube availability and low signal temperature drifts.

The assembly of electromultipliers used in the tube requires microlaser welding. Unfortunately the assembly phase coincided with the failure and replacement period of the welder. Attempts to use other welding methods resulted in shorts. The replacement laser welder later yielded a usable electronmultiplier and tube. A spare tube was later contracted for and produced without problems.

Low signal temperature drifting occurred in the area of an analog multiplier in the signal channels. The sensitivity of the tube photocathode across the tube diameter changes as does the optic transmission, lamp brightness and to a lesser degree filter transmission. A major degree of signal level correction on the scan line signal is achieved by generating an inverse-of-shading signal and multiplying it times the signal level. As the internal cabinet temperatures vary from room ambient to 45 to 55°C, the analogue multiplier integrated circuits were found to vary up to 100 milliwatts with zero (black) signal levels.

This was corrected by developing a reverse compensation bias voltage to the offsetting input pin of the analogue multiplier. Red and blue channel drift was reduced to less than 10 MV and the green channel reduced to 10 MV. Further improvement is possible if required, with more correction, possibly, to less than 3 or 4 MV in all channels. More accurate analogue multipliers are also now available having wide temperature range capability.

8.0 OUTPUT FORMS

Three separate outputs are available from the DCS. Paper tape, analog histograms and digital magnetic tape (see Figures 19, 20 and 21). The paper tape printer requires approximately 51 seconds for a data record printout. It is intended only as a quick look at the data being accumulated at the point in time when "Manual Start" is actuated. In "AUTO" mode, it runs continually, printing out every 17th data record.

The analog histogram reads the system output as it passes to the magnetic tape. A digital-to-analog converter is placed ahead of the Gould Instrument Oscilloscope.

The third and most complete output is a Digi-Data Corporation digital tape recorder. Thumbwheel switch numbers appear on the tape as the HDR switch is actuated, this is then followed by data records for as long as practical.

The MPE Paper Tape printer, Gould Instrument Oscilloscope and Digi-Data Recorder operation and maintenance manuals are included in this Handbook.

DENSITY	RED		GREEN		BLUE	FINISH
3.0	0 0 0		0 0 0		0 0 0	
2.9	0 0 1		0 0 0		0 0 2	
2.8	0 0 0		0 0 0		0 0 1	
2.7	0 0 0		0 0 0		0 0 0	
2.6	0 0 0		0 0 1		0 0 1	
2.5	0 0 2		0 0 2		0 0 1	
2.4	0 0 1		0 0 2		0 0 2	
2.3	0 0 3		0 0 2		0 0 2	
2.2	0 0 4		0 0 2		0 0 3	
2.1	0 0 4		0 0 4		0 0 3	
2.0	0 0 5		0 0 5		0 0 6	
1.9	0 0 7		0 0 6		0 0 6	
1.8	0 0 8		0 1 0		0 0 8	
1.7	0 1 0		0 1 0		0 1 0	
1.6	0 1 6		0 1 3		0 1 4	
1.5	0 1 7		0 1 7		0 1 7	
1.4	0 2 1		0 2 2		0 2 1	
1.3	0 2 7		0 2 7		0 2 7	
1.2	0 3 4		0 3 4		0 3 4	
1.1	0 4 3		0 4 3		0 4 3	
1.0	0 5 4		0 5 4		0 5 5	
0.9	0 8 4		0 6 8		0 6 9	
0.8	0 8 5		0 8 6		0 8 6	
0.7	1 3 0		1 0 9		1 1 0	
0.6	1 6 5		1 5 4		1 3 9	
0.5	1 7 3		1 9 5		1 7 8	
0.4	2 2 1	Peak R	2 1 3	Peak G	2 3 3	Peak B
0.3	0 5 4		0 4 8		0 1 2	
	0 0 0	Border Indication				
	0 0 1	FRAME NO.				

Multiplier (X2^N)
 { 0 0 0
 9 9 9
 9 9 9
 0 7 3
 0 4 1 }

MODE
 FILE
 DATE

START

Figure 19 Typical Paper Tape Output
31

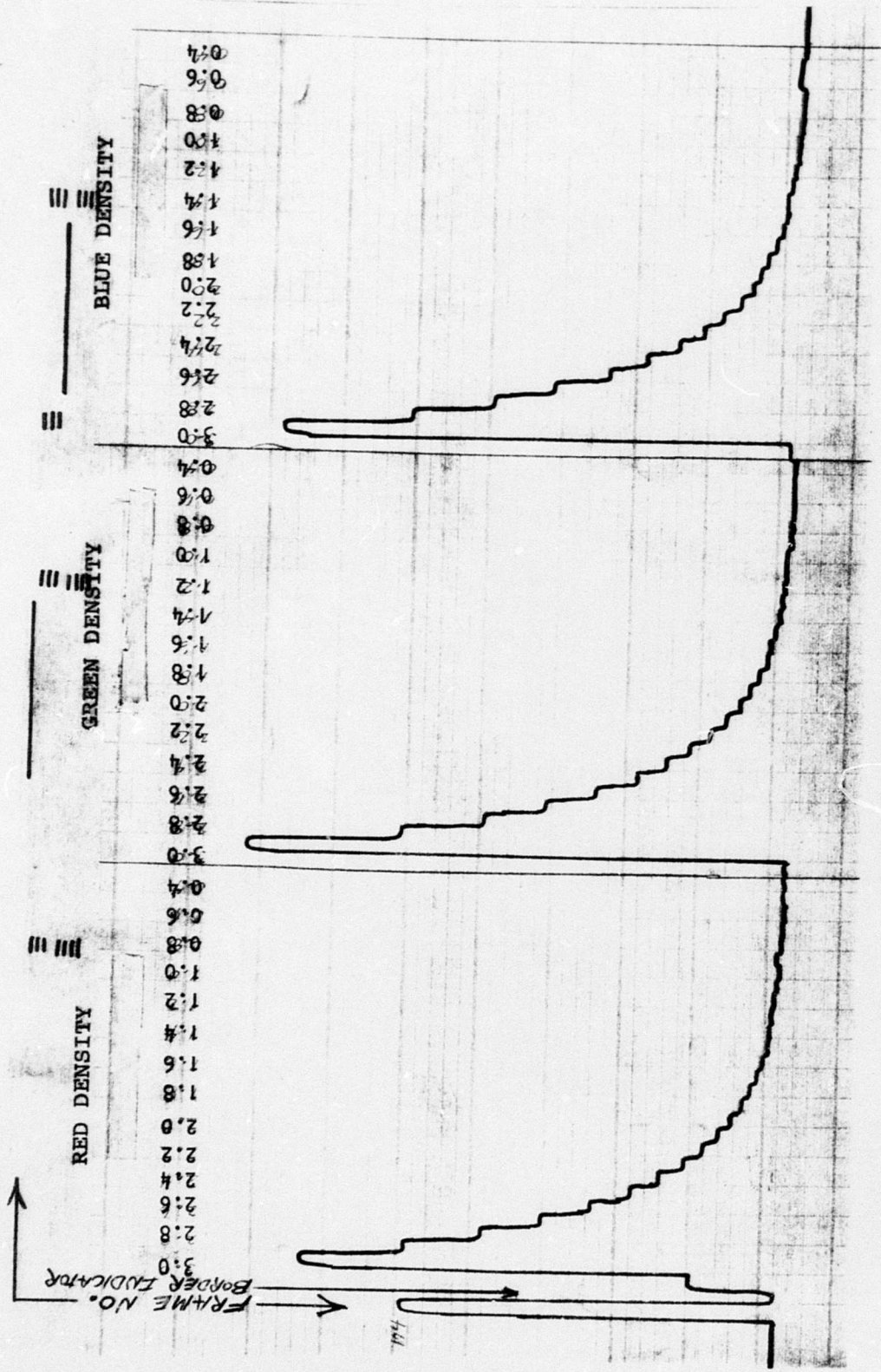

Figure 20 Typical Oscilloscope Output, (Test Video Input)

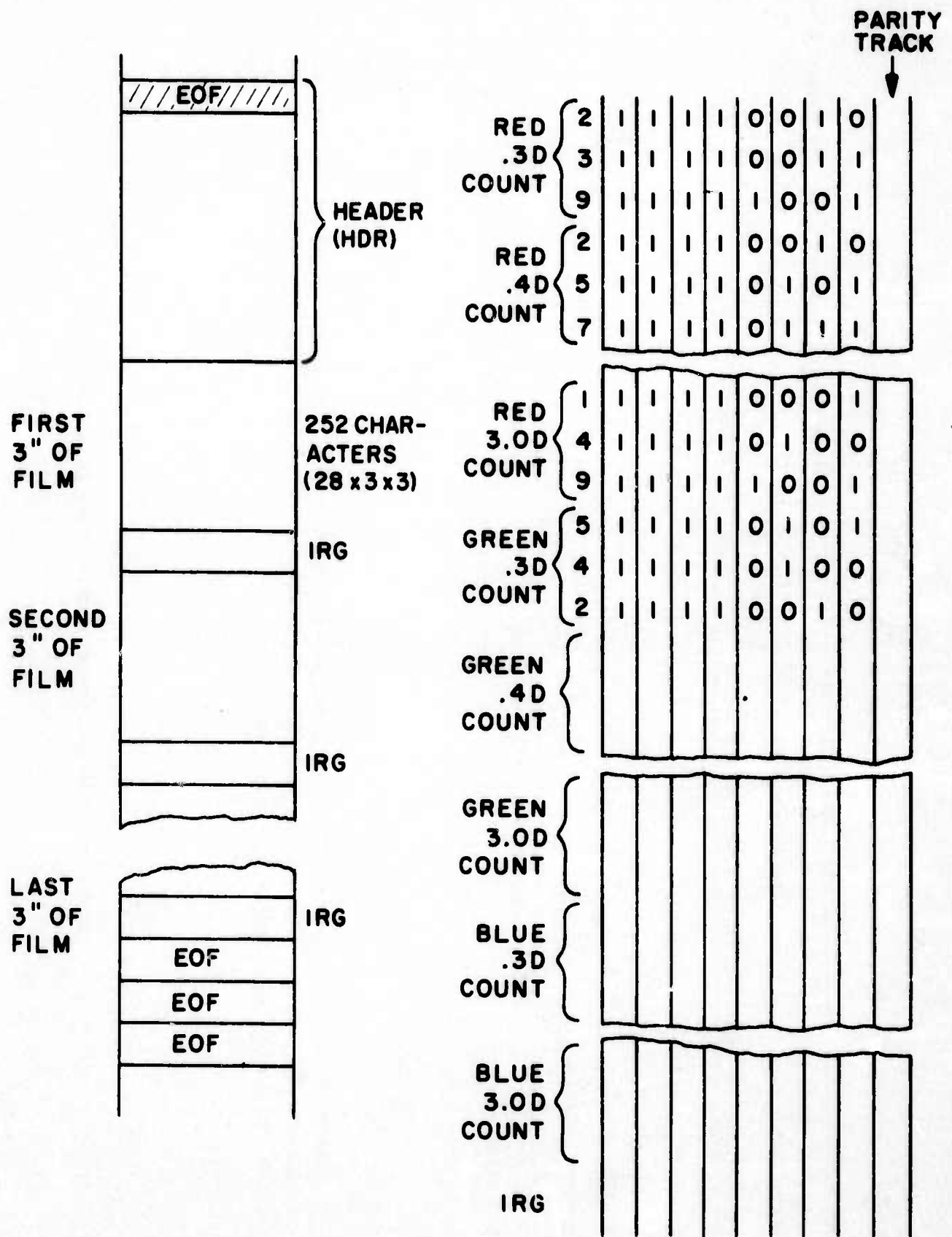
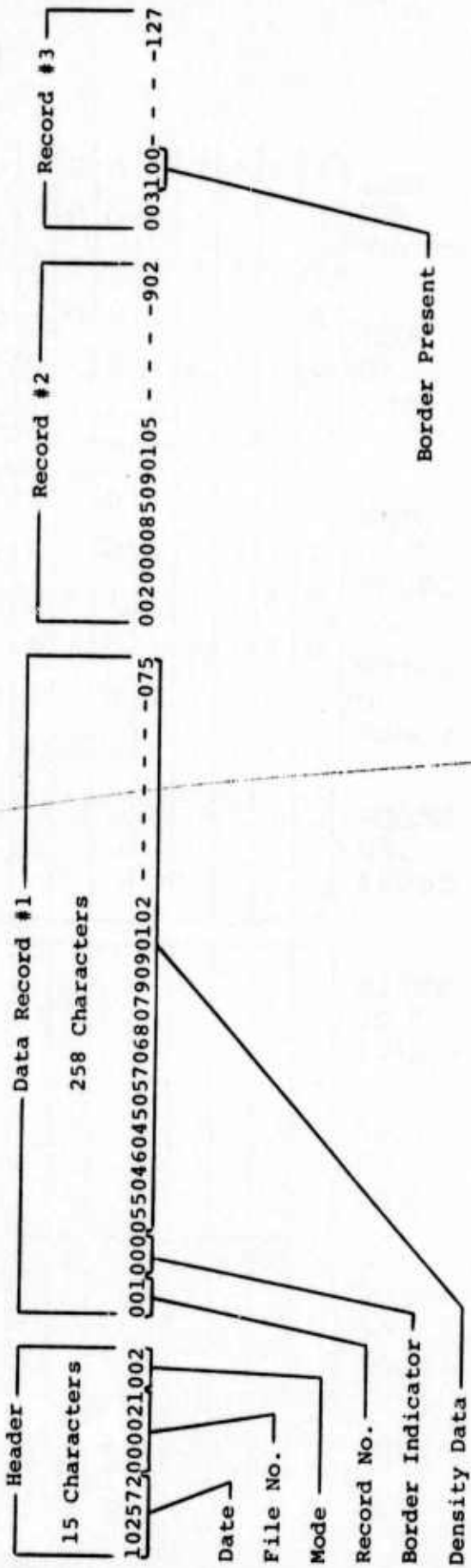

Figure 21 Magnetic Tape Organization



The recorded tape consists of a 15 character header and a quantity of data records of 258 characters each. One EOF precedes the header and three EOF follow the final data record. IRG's are inserted after the header and between all data records.

Figure 22 Dynamic Color Scanner Tape Organization

RELATED DOCUMENTATIONS

1. Equipment Manual #8008566 dated April 2, 1973.
Volume I describing operation
Volume II handbooks for recorders, power supplies, etc.
2. Monthly Reports
June 1, 1972 to July 31, 1972
Aug. 1, 1972 to Sept. 1, 1972
Sept. 1, 1972 to Oct. 1, 1972
Oct. 1, 1972 to Nov. 1, 1972
Nov. 1, 1972 to Dec. 1, 1972
Dec. 1, 1972 to Jan. 1, 1973
Jan. 1, 1973 to Feb. 1, 1973
Mar. 1, 1973 to April 30, 1973
May 1, 1973 to Aug. 31, 1973
3. Test Procedure #8008555
4. ITT Proposal No. 71-1069, Aug. 13, 1971
5. Contract No. F33615-72-C-2071

DYNAMIC COLOR SCANNER CHARACTERISTICS

Film Width	9-1/2 inch to 70MM
Film Rate	1 inch per second
Scan Width	4-1/4 and 2-1/4 inch
Spectral Bands	440, 550 and 668 nanometers
Spectral Bandwidth	20 \pm 2 nanometers
Density Range	0.3 to 3.0 (resolvability .1D)
Film Length/Histogram	3 Inches
Samples Collected/Histogram	1,022,976 Max. (100% area) 63,936 Min. (6.25% Area)
Samples Outputted/Histogram	28,000 Max.
Samples Per Line	1152
Scan Rate:	296 Lines/Sec. Max. 18.5 Lines/Sec. Min.
Outputs	9 Track Magnetic Tape (IBM) Oscillograph (Analog, 100% Duty Cycle) Paper Tape (6.2%, Duty Cycle)

DOCUMENT CONTROL DATA - R & D

(Security classification of title, body of abstract and indexing annotation must be entered when the overall report is classified)

1. ORIGINATING ACTIVITY (Corporate author)

ITT Aerospace/Optical Division
3700 E. Pontiac St.
Fort Wayne, Indiana 46803

2a. REPORT SECURITY CLASSIFICATION

Unclassified

2b. GROUP

3. REPORT TITLE

Dynamic Color Scanner System,

4. DESCRIPTIVE NOTES (Type of report and inclusive dates)

Final Report, June 72 - May 74

5. AUTHORIAL (Last name, middle initial, first name)

Louis T. Hunkler

12 44p.

6. REPORT DATE

May 74

7a. TOTAL NO. OF PAGES

42

7b. NO. OF REFS

8. CONTRACT OR GRANT NO.

F33615-72-C-2071

8a. ORIGINATOR'S REPORT NUMBER(S)

9. PROJECT NO.

6369A3

9b. OTHER REPORT NUMBER(S) (Only numbers that may be assigned)

18 AFAL-TR-74-151

10. DISTRIBUTION STATEMENT Distribution limited to U.S. Government agencies only; test and evaluation; 30 Jan. 1973. Other requests for this document must be referred to Air Force Avionics Laboratory (AFAL/RSP) WPAFB, Ohio, 45433.

11. SUPPLEMENTARY NOTES

12. SPONSORING MILITARY ACTIVITY

Air Force Avionics Laboratory
Wright-Patterson AFB, Ohio

13. ABSTRACT

A three-aperture image dissector television tube is employed in a three-color photographic film densitometer. Equipment was assembled to accept reel film up to 9 inches in width, measure density, accumulate measurements and generate histograms describing the film density distribution. Sample size at the film plane is 94 microns with the number of samples per histogram variable to 10^6 . Each sample is classified as a density between 0.3 to 3.0 in 0.1 density increments. Histogram outputs are on oscillograph, paper tape and magnetic tape. Program details were reported in monthly and this final report as well as an equipment manual.

1,000,000

389042

JB