

UNCLASSIFIED

AD NUMBER

ADB014926

LIMITATION CHANGES

TO:

Approved for public release; distribution is unlimited.

FROM:

Distribution authorized to U.S. Gov't. agencies only; Contractor Performance Evaluation; 01 OCT 1976. Other requests shall be referred to David Taylor Naval Ship Research and Development Center, Code 186A, Bethesda, MD 20084.

AUTHORITY

usnsrdc ltr, 1 aug 1977

THIS PAGE IS UNCLASSIFIED

UNCLASSIFIED

AD NUMBER

ADB014926

LIMITATION CHANGES

TO:

Distribution authorized to U.S. Gov't. agencies only; Contractor Performance Evaluation; 1 OCT 1976. Other requests shall be referred to David Taylor Naval Ship Research and Development Center, Code 186A, Bethesda, MD 20084.

FROM:

Distribution authorized to DoD only; Contractor Performance Evaluation; 27 SEP 1976. Other requests shall be referred to David Taylor Naval Ship Research and Development Center, Computation and Mathematics Department, Bethesda, MD 20084.

AUTHORITY

1 oct 1976, usnsrdc per document marking

THIS REPORT HAS BEEN DELIMITED  
AND CLEARED FOR PUBLIC RELEASE  
UNDER DOD DIRECTIVE 5200.20 AND  
NO RESTRICTIONS ARE IMPOSED UPON  
ITS USE AND DISCLOSURE.

DISTRIBUTION STATEMENT A

APPROVED FOR PUBLIC RELEASE;  
DISTRIBUTION UNLIMITED.

# Technical Report

2

NAVPHOTOGEN R&D 76/11

Photographic Video Disc Technology Assessment

Final Report FY76

Distribution Limited to U.S. Government Agencies Only:  
Contractor Performance, 1 October 1976, Other Requests Must be  
Referred to David W. Taylor Naval Ship Research and Development  
Center, Bethesda, Maryland 20084

RECEIVED  
NOV 15 1976  
D D D  
B

(Code 186A)

ADB014926

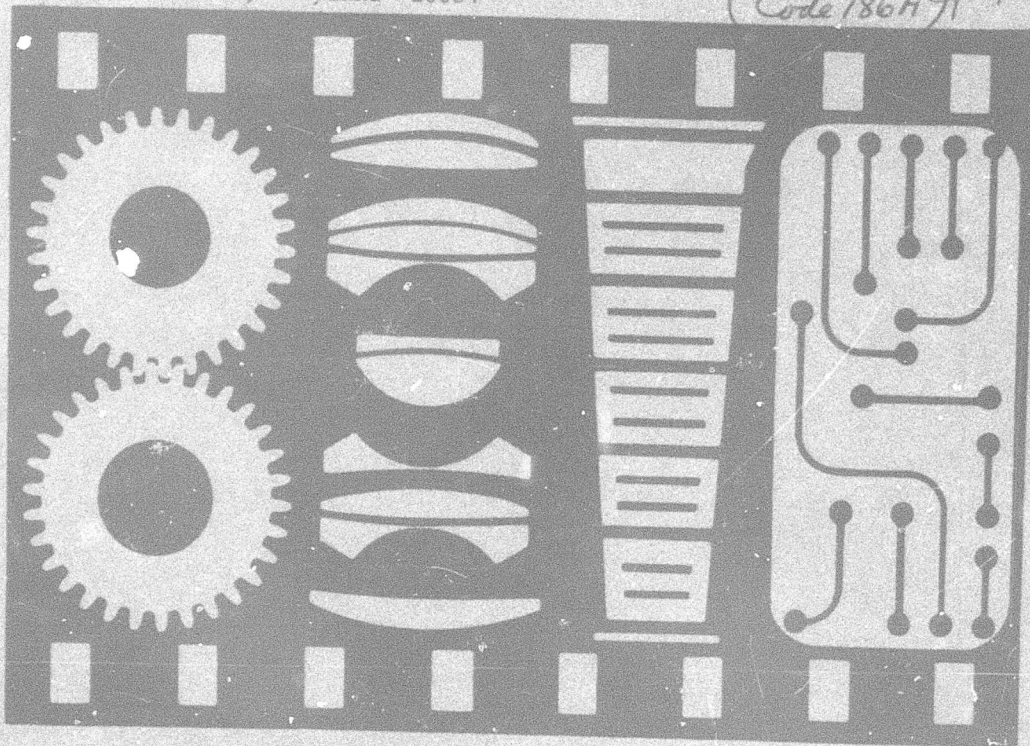

AD No. \_\_\_\_\_  
DDC FILE COPY

~~Each transmittal of this document outside the Department of Defense must have prior approval of David W. Taylor Naval Ship R&D Center, Computation & Mathematics Dept., Bethesda, Md. 20084 (Code 186A)~~

Naval Photographic Center  
Research and Development Department  
NDW, Anacostia  
Washington, D.C. 20374

NAVAL PHOTOGRAPHIC CENTER  
RESEARCH AND DEVELOPMENT DEPARTMENT  
WASHINGTON, D.C. 20374

27 September 1976

No. of Pages 15

NAVPHOTOCEN R&D 76/11

Photographic Video Disc Technology Assessment

Prepared by: G. C. Bull  
G. C. BULL  
Project Officer, R&D Department

Reviewed by: C M Keating  
C. M. KEATING  
Asst. Head, R&D Department

Approved by: R. W. Lewis  
R. W. LEWIS, LCDR, USN  
Head, R&D Department

Released by: L. C. Miles  
L. C. MILES, CAPTAIN, USN  
Commanding Officer

ACCESSION for	
NTIS	White Section <input type="checkbox"/>
DDC	Buff Section <input checked="" type="checkbox"/>
UNANNOUNCED	<input type="checkbox"/>
JUSTIFICATION.....	
BY.....	
DISTRIBUTION/AVAILABILITY CODES	
Dist.	AVAIL. and/or SPECIAL
B	

DDC  
RECEIVED  
NOV 15 1976  
B

UNCLASSIFIED

Security Classification

DOCUMENT CONTROL DATA - R & D

(Security classification of title, body of abstract and indexing annotation must be entered when the overall report is classified)

1. ORIGINATING ACTIVITY (Corporate author)  
Research and Development Department  
Naval Photographic Center  
Washington, D.C. 20374

2a. REPORT SECURITY CLASSIFICATION  
UNCLASSIFIED

2b. GROUP

6. REPORT TITLE  
Photographic Video Disc Technology Assessment

9. DESCRIPTIVE NOTES (Type of report and inclusive dates)  
Final Technical Report for FY 76

5. AUTHOR(S) (First name, middle initial, last name)

10. Glen C. Bull

6. REPORT DATE

11/27 Sep 76

7a. TOTAL NO. OF PAGES

12/62 p.

7b. NO. OF REFS

8a. CONTRACT OR GRANT NO.

b. PROJECT NO.

c.

14. ORIGINATOR'S REPORT NUMBER(S)

NAVPHOTOCEN-RD-76/11

9b. OTHER REPORT NO(S) (Any other numbers that may be assigned this report)

Distribution limited to U.S. Gov't. agencies only;

Contractor Performance Evaluation: 1 Oct 1976

Other requests for this document must be referred to Naval Ship Research & Development Center Code 186A, Bethesda Md 20084

11. SUPPLEMENTARY NOTES

12. SPONSORING MILITARY ACTIVITY

DAVID W. TAYLOR, SHIP R&D CENTER  
COMPUTATION & MATHEMATICS DEPT.  
BETHESDA, MD. 20084 (CODE 186A)

13. ABSTRACT

This report covers investigative research conducted into high density recording technologies for the Navy Technical Information Presentation Program (NTIPP).

Mechanical and optical storage and retrieval systems have been investigated, potential manufacturers visited, patents, technical literature and other pertinent data thoroughly studied, and an outside consultant employed to complement this study.

As of this date all disc technology by manufacturers within the United States is developmental. Several firms, state they could begin marketing a player within twelve months. However, all systems have various development problems yet to be overcome.

For medium volume distribution as required for the NTIPP, a photographic recording and replication medium should prove to be the most advantageous system.

Within the time frame of the NTIPP development phase, many of the recording and distribution methods discussed in this report will be fully developed. Their inherent capability for random access retrieval of textual data, and within the same record, inclusion of motion, color, or sound as desired, will make "video discs" the prime contender as the most logical and cost effective system for use in the NTIPP.

251 375

600

14 KEY WORDS	LINK A		LINK B		LINK C	
	ROLE	WT	ROLE	WT	ROLE	WT
High Density Recording Technology Video Disc Packing Density Recording - Laser Beam - Electron Beam Playback Unit Analogue Signal Digital Signal Impression Stamping Photographic Replication Electrostatic Deformable Plastic Dye Imaging PAL - 1500 rpm (Phase Alternation Line) European Standard Color Video NTSC - 1800 rpm (National Television System Committee) U. S. Standard Color Video Acoustic Optical Random Access Human Engineering						

## TABLE OF CONTENTS

		Page No.
I	OBJECTIVE	1
II	APPROACH	1
III	FACTUAL DATA	3
	A. BACKGROUND	3
	B. DISCUSSION	4
IV	APPLICATIONS	8
V	RESULTS	9
VI	CONCLUSIONS	10
VII	RECOMMENDATIONS	15



## I OBJECTIVE

A. The general objective of the Navy Technical Information Presentation Program (NTIPP), of which this study is a part, is to provide an integrated system to produce, revise, distribute, retrieve, monitor use of, provide feedback for, and track cost of technical manuals (TM's) while improving the operation and maintenance of Navy hardware systems.

B. The objective of this project is to monitor developments within the "Video Disc" and mass information storage technology fields for potential applications to the NTIPP.

## II APPROACH

A literature search was initiated to study those American firms known to be actively engaged in research on some form of disc technology. Those manufacturers expected to eventually offer a hardware or software product for the home, industrial, educational, or Government markets are as follows:

Ampex Corporation  
401 Broadway, M/S 3-21  
Redwood City, CA 94063

Bell & Howell Company  
6800 McCormick Road  
Chicago, ILL 60645

Digital Recording Corporation  
P.O. Box 6  
Scarborough, NY 10510

Electronics & Optical Systems Research  
Philips Laboratories  
345 Scarborough Road  
Briarcliff Manor, NY 10510

Gotham Audio Corporation (TED)  
741 Washington Street  
New York, NY 10014

IBM Corporation  
Parsons Pond Drive  
Franklin Lakes, NJ 07417

Logicon Corporation  
21535 Hawthorne Blvd.  
Torrance, CA 90503

MCA Disco-Vision  
100 Universal City Plaza  
Universal City, CA 91608

3M Company  
Duplicating Products Division  
3M Center, Building 235-E13  
St. Paul, MINN 55101

Video Disc Recorders, Inc.  
1901 Avenue of the Stars, Suite 1630  
Los Angeles, CA 90067

Xerox Corporation  
Palo Alto Research Center  
3333 Coyote Hill Road  
Palo Alto, CA 94304

Zenith Radio Corporation  
1900 North Austin  
Chicago, ILL 60639

I/O Metrics Corporation  
Sunnyvale, California 94086

### III FACTUAL DATA

#### A. Background

During the latter half of the 1960's, a number of consumer electronics manufacturers in the USA, Europe, and Japan began to explore new types of video equipment which would permit the packaging and marketing of entertainment, educational, and industrial audio-visual programs. The record used in this new high density recording technology is often referred to as a "video disc", although not truly a disc in all instances. This record would be placed upon a "video player" similar to the ordinary phonograph record player and attached to the TV antenna on one's TV set. The record could contain a TV program, in full color, such as a movie or event. By use of this high density recording technology, these records can be manufactured and commercially marketed for an estimated cost of between \$2.00 and \$10.00 for the disc, depending on royalty or license cost for program material. The projected cost of the player device for the records is estimated at from \$200 to \$1000 depending on the manufacturer and capabilities of the device.

## B. Discussion

1. The idea of packaging video programs for entertainment use is not new. Since Americans spend billions of dollars on phonograph records every year, it is highly probable that video recording holds vast economic promise particularly for the home entertainment and educational fields.

2. While the high packing density capability of electro/optical laser recording has been known to engineers for some time, the technological problems of mass producing the systems economically have had to be overcome.

3. Most all video recording systems operate on a principle of making a permanent record of the stream of electrical impulses which constitute a TV signal, then recreating that signal on a TV screen when the record is played back. Television, like the movies, creates an illusion of motion by presenting a series of pictures in rapid sequence, each one slightly different from its predecessor. This illusion of motion requires 30 frames per second for television, or 54,000 individual frames of information per half hour record. Each TV frame consists of approximately 100,000 impulses (or more properly, "bits"). This means that the video disc system must handle 3 million separate and distinct bits every second. All this data, or

programming, must be contained on a record for mass distribution to the user.

4. In the true "Disc" system, as presented in enclosures (1) through (5), the disc is turned rapidly (1800 r.p.m. NTSC, 1500 r.p.m. PAL) so that the track of recorded information moves past a scanning point which transforms light variations into an electrical impulse as each separate bit passes. When successive recorded bits vary in any discernible manner, variations occur in the stream of impulses emanating from the scanning point and are transmitted, amplified and presented on the TV screen as successive changes of light value from spot to spot, thus forming a visible image on the screen.

5. A second system concept and record format is presented by Digital Recording Corporation in enclosure (6). The record is rectangular and fixed in position. The data is read by a spinning multi-lens scanner located under the record and moved along the length of the record to provide the data stream of video information.

6. There are two basic methods of record preparation and replication to be used in optical play back devices: The impression stamping method employed by Zenith, MCA-Philips, RCA and others and the photographic method used by I/O Metrics and Digital Recording Corporation.

a. Impression Stamping.-- Impression stamping requires an expensive, complicated and exacting process. The cost of equipment to prepare the master disc and to manufacture the stamped duplicates is approximately \$250,000. This process requires approximately 4 hours. After masters are made, the duplicate records can be manufactured very economically for large distribution requirements. Only in extremely high quantities does the impression stamped record become cost effective over photographic reproduction. Companies, such as MCA/Philips, are presently having difficulties with consistent replication of discs in mass production.

b. Photographic Recording

1. Photographic recording and duplication can be done much faster, and cheaper for smaller distribution requirements. The program is recorded on the original photosensitive record in real-time, processed by photographic methods and contact printed for duplicate records. The cost of the device for photographic recording is estimated at \$35,000.

2. I/O Metrics discs could be duplicated on special die cut film in any photographic laboratory equipped with a high resolution contact printer. Special high volume printers could be manufactured to allow

automated production rates up to 2500 per hour. DRC records should be able to be duplicated on high resolution aerial roll film printers at rates between 10,000 and 20,000 per hour.

3. The signal recorded on film in the two photographic systems differ in that the present I/O Metrics signal is recorded in AM analogue format and the DRC signal is converted to digital format before recording. It is felt that the digital signal has several advantages, and a digital signal conversion by I/O Metrics or any other manufacturer is possible. Digital format signals are easier to utilize by computers, and NTIPP systems will probably be computer controlled to some extent. The digital signal is also far easier to record and duplicate in the photographic format. The recorded high contrast spots form binary numbers which differ from the definite shape and pattern of analogue signals. The spots can be duplicated through many generations without an increase in signal-to-noise ratio due to image degradation of the analogue signal shape.

4. Photographic duplication could be accomplished in field locations for local use. At present, real-time playback is not commercially possible on "Video Discs", but development work is under way for real-time

playback through use of electrostatics, dye imaging, heat deformable plastics, photopolymers and other promising techniques which may be feasible within the time frame of the NTIPP.

c. Magnetic Video Tape.-- On magnetic video tape, the individual "bits" of the TV pictures are indeed small, but for a half-hour program it still takes about 1100 feet of tape, 2 inches wide, or nearly 200 square feet of tape surface, to hold all program bits. The video disc, due to the data packing ability of optical-laser recording, can reduce the same program onto space about one-half of one square foot of surface. Technology being developed in data compression techniques promises vastly higher packing density within the time frame of the NTIPP.

#### IV APPLICATIONS

A photographic disc (or other type record) carrying the equivalent of approximately 54,000 facsimile pages of information can be utilized in almost any desired format or presentation method. Text, graphics, still frames, audio or full sound motion picture action are available to the user as programmed for presentation. If utilized on a color TV screen the program may be either black and white or full color as desired. Headings, chapters, pages or programs can be retrieved on demand by random access command.



This information would be displayed on a standard or high resolution TV screen. After selection of a program or location of a page of desired information, hard copy printout is available utilizing electrostatic reproduction from the video screen or through high speed mechanical printout. If the information is graphic or pictorial, the operator could "blow up" (increase the size of) the desired section of the graphic display, press a button for hard copy and obtain the desired copies. If large engineering drawings are being displayed, a "Plasma Panel" device is available which would display the information in sizes up to a class D drawing. This screen is not suitable for motion or continuous tone photographs but is excellent for graphics. The signal is compatible to both CRT and Plasma Panel presentations.

## V RESULTS

### A. Photographic Discs

1. The I/O Metrics Corporation, see enclosure (1), has been experimenting with photographic discs and has demonstrated an inexpensive method of photographic recording in which the disc can record one full hour of TV. It is also claimed that the playback system, which can be attached to any commercial TV set, will retail for under \$300.

2. Digital Recording Corporation (DRC), enclosure (6), utilizes a rectangular format or a film strip contained in a short cassette. This film could be advanced and scanned in frame format and would provide variable program length. The company also claims a unique data compression and redundancy removal system which will allow a 20 to 30 minute program to be distributed on a film chip the size of a standard IBM card. The DRC player is forecast in the same price range as the I/O Metrics player.

3. Both photographic systems utilize a visible photographic image of the recorded signal. Regardless of signal format, direct analogue or an A/D converted digital signal, it is recorded by modulated laser beam and can be read out by either laser or incandescent light. Laser read-out has several advantages, in that coherent light can be directed more accurately, holographic lens systems for light control can probably be utilized in the near future, and acousto-optical techniques can be utilized to reduce the moving parts within the recorder or player.

## VI CONCLUSIONS

It is concluded that:

A. Although this is a final report on FY76 investigations, continuing survey of the industry is

required to keep abreast of developments applicable to the NTIPP. The Naval Photographic Center is also interested in this technology for distribution of motion picture programs and in intelligence gathering through recording of signals from electro-optical sensors.

B. Research activity in the area of acousto-optical control of coherent light beams has made progress recently. It is certainly reasonable to anticipate that "in the future" all scanning of optical data stores, can be carried out by electronic means, thereby removing virtually all moving parts from the playback unit.

C. Electro/Optical recording and playback technology using photographic discs (or other) type records, are systems that can play a viable part in the NTIPP.

D. The coupling of this system with electrostatic and other reproduction devices to provide immediate hard facsimile copy from the video display screen is commercially available and should be considered as "state of the art".

E. The extreme high density packing of recorded data that can be placed upon a video disc via laser or electron beam recording techniques, should supercede microfilm as a means of storage and retrieval of data in most applications. The ability to freeze frame, fast forward and reverse, and

random access retrieval are all capabilities of this new technology. The inclusion of both sound and motion make these potentials ideal for the NTIPP.

F. A recording/playback system for archival storage of information, with random access retrieval through digital signals can result in an information density three million times greater than the original material and approximately 8000 times greater than microforms.

G. Video presentation of information is highly practical for the NTIPP. This has been verified in Human Engineering studies for the NTIPP.

H. Computerization of an entire system is within the "state of the art" and there are cost effective alternatives to the use of large "Main Frame" computers in control of this system. Variations of micro-processor controls, combined with digital format information, will allow sophisticated information storage and information handling. For example, digital addresses on each frame within a record could allow programmed, "computer-aided" type of instruction or information presentation without the cost or complexity of a computer.

I. Many video disc concepts are quite similar but, much additional development and money is required before

any system can be marketed either for commercial or Government use. Each has its advantages and disadvantages. However, photographically prepared records for the NTIPP outweigh other known technologies currently available.

J. The high volume entertainment market is the initial goal of the larger industrial firms such as MCA-Philips, Zenith, RCA, TED (Berlin), etc.

K. Technical manuals prepared in the photographic "disc" format can be updated by reissue of a new "disc". The entire new manual can then be issued at the approximate cost of the present page change.

L. Problems in the materials and methods for replication of discs is the main obstacle to marketing of stamped impression video discs at this time. The photographic systems also need further development before introduction.

M. It is too early in our study to state with emphasis the desirability of one manufacturer's concept over another. Further studies must be made. It is highly probable that new concepts will be forthcoming from high density recording and playback technology.

N. Many firms are working on "Video Disc" technology and much information has been forthcoming from these firms and the media. To provide descriptions of the prime systems, descriptive copyrighted data has been included as enclosures in this report.

O. There appears to be an effort being made between several firms to standardize on compatible software in which the discs could be interchanged between players.

P. The photographic system appears most desirable at this time for the NTIPP and most military applications.

Q. Technologies, when available for real-time recording and playback from video-discs, will offer serious competition to the magnetic tape industry.

R. There is only one known video-disc system being commercially marketed at this time, i.e., the TED pressure-grooved system manufactured by Telefunken A.G., Berlin, W. G. This system is considered unsuitable for NTIPP.

VII RECOMMENDATIONS

It is recommended that:

A. This report be made available to other DoD activities, and that Tri-service applications and requirements be coordinated.

B. Data in these reports be turned over to the NTIPP prime contractor.

C. That there be continued contact and coordination between The Naval Photographic Center, R&D Department and NTIPP personnel.

D. This study effort be continued.

#### COPYRIGHT PERMISSION

Permission to republish all or parts of the following text material has been granted by the Society of Motion Picture and Television Engineers and the Society for Information Display.

By republishing articles written by employees of each of the following manufacturers, seriously involved in video disc technology, it is hoped that they will be received as being authentic at least to the hour and date of their publication.

1. Systems Application of Film-Based Optical Video Discs, Jonathan A. Jerome, I/O Metric Corp.
2. A Review of the MCA Disco-Vision System, Kent D. Broadbent, MCA Disco-Vision, Inc.
3. The Philips 'VLP' System, K. Compaan and P. Kramer.
4. An Experimental Optical Videodisc Playback System, George W. Hrbek, Zenith Radio Corp.
5. The RCA "SelectaVision" VideoDisc System, Corporate Paper.
6. Digital Recording. An Optical System for High Density Information Storage and Retrieval. Corporate Paper.



ENCLOSURE 1

Systems Application of Film-Based Optical Video Discs  
Jonathan A. Jerome, I/O Metric Corp.

# systems application of film-based optical video discs

Jonathan A. Jerome  
I/O Metric Corporation

Initial research and development of video discs have been directed to one limited goal: the retrieval of ten to thirty minutes of video and video-synchronized audio from one disc of approximately thirty centimeters diameter. The video and audio signals are to be compatible for playback on any typical, non-professional consumer television set, via transmission to the external antenna input of the set. Numerous systems to accomplish this goal have now been demonstrated. Attention is now centered on the further refinement of the demonstrated systems, and on the extension of the video disc capability to new areas of application. A summary of several of these potential areas of application is presented in Table I, along with an indication of the required disc formats and the disc player configurations. Also described in Table I is the consumer-compatible application, and some of the desirable features which could be added to the basic playback device.

APPLICATION	DISC PARAMETERS	PLAYBACK DEVICE CONFIGURATION
1. Video Playback	10-30 min. playing time from continuous video signal on spiral track	Realtime forward/reverse, stop frame, optional slow crawl/rapid advance
2. Video Visual Image Store	5,000-50,000 indexed circular video tracks	Computer controlled rapid-random access
3. Educational/Institutional	Segmented video signal on spiral track	Programmed interactive playback under local computer control
4. Read Only Memory/High Density Data Store	Circular video or circular computer compatible digital tracks	Fixed head, electronically switched video/digital read

Table I Applications and parameters/playback configuration for video disc systems.

Page 6 / Information Display

Simple continuous retrieval of the video and audio information from a spiral track or a set of circular tracks can be accomplished by means of several different technologies, utilizing either magnetic, capacitive, mechanical, or optical means. However, whenever additional system requirements are introduced, such as extended stop-frame or rapid random access, only optical retrieval offers a significant capability. Indeed, even the simple system requirement of maintaining file integrity in use will in most applications eliminate all but an optical retrieval. Typical capacitive and mechanical retrieval means are limited to approximately 100 passes at the data on the disc, at which point significant degradation is introduced. Magnetic storage of the information on the disc does not provide archival protection in the presence of small thermal and magnetic shocks.

A final consideration with respect to systems applications of optical-based video discs is the overall ease with which the video disc component of the system may be used. A film-based video disc technology offers maximum flexibility in those areas where only small numbers of copies are made, and where mastering and duplicating costs would otherwise dominate. A non-film based optical technology requires a complex sequence of steps to generate a playable copy. For example, to generate a pressed PVC disc for use with an optical readout, the following steps are required: first, a metal coated glass master is mounted. The video signal is burned into the metal coating using a high power laser. The metal coating is subsequently over-coated with a layer of photoresist that is exposed through the under-surface of the disc to ultra-violet light. A negative working photoresist is used, so subsequent development leaves only the exposed areas. Finally, electrodeposition of an appropriate metal on the photoresist yields a stamping tool which may be used to press PVC discs. In contrast, a photographic film disc is exposed with a low power laser, and developed in under ten minutes in a simple automated film processor. Here, the master photographic film disc is immediately playable, or may be used to generate copies by means of a simple contact printing process.

In order to exploit these basic advantages of the film-based video disc technology, development of the recording and playback capability, as described below, has been in the direction of greatest ease and most natural execution.

## FILM DISC RECORDING

The actual recording process for a given video film disc depends on the eventual application in which the disc will be

used. A general recorder has been developed which is consistent with recording file-indexed circular tracks or a continuous spiral at arbitrary densities exceeding 500 tracks/mm. The optical layout of the recorder is presented in Fig. 1. In detail, a low power 3mw HeNe laser delivers light to an acousto-optical modulator. The signal of interest is induced on the laser beam by means of the modulator driver. This signal can be either the direct analog video signal, or a frequency or pulse position modulated video signal, or in general any analog or digital signal. The modulated laser beam is delivered to the surface of the film disc by an ordinary microscope objective, with a numerical aperture chosen between 0.1 and 0.8, depending on the particular application. Further details include a beam contractor before the modulator; and a set of transfer optics to match the aperture of the modulated beam to that of the microscope objective.

## Laser Disc Recorder

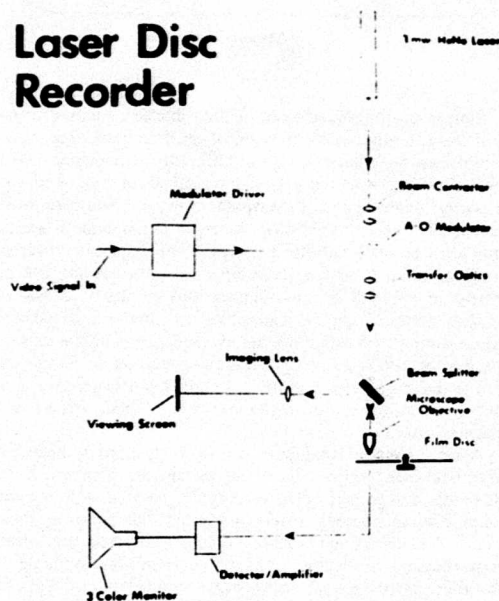

Figure 1. Optical/mechanical layout of the laser disc recorder for recording the floppy disc mode.

All recording is carried out directly on the film sheet in a floppy disc mode without using any rotating supporting substrate. Historically, film-based disc recording was carried out using emulsions bonded directly onto glass plates, or film sheets mounted on large optical flats. This use of massive glass substrates introduces considerable mechanical difficulty and also considerable danger, as the discs must be rotated in excess of ten times per second. Elimination of the glass substrate by recording directly on the film sheet supported only by an air bearing significantly simplifies the mechanical configuration and also makes the practicing of the recording process significantly easier.

The most severe mechanical constraint remaining is that the disc must spin flat to the depth of focus of the recording objective, or several microns. The film disc is a  $100\mu$  thick mylar sheet with an emulsion on the order of  $5\mu$  thick; it is spun some hundreds of microns above an appropriately

configured stationary support plate. The rate of rotation required by video and high bandpass digital recording, in excess of 10Hz, is sufficient to flatten the disc at any one fixed radius to several microns. The film sheet is of course a flexible membrane, and hence acquires a radial profile in rotation. By appropriate choice of the support plate, the air bearing will generate a profile flat to within  $10\mu$  over the disc radii at which recording is carried out. Fig. 2 shows a typical disc profile as measured on the recorder. Note that the most rapid variation of vertical position of the disc surface occurs at the larger radii, where the signal recorded is least affected by such variations. Fortunately, a given disc profile does not seem highly sensitive to local irregularities (on the order of  $50\mu$ ) of the stationary support plate. Instead, only the global character of the plate and the air flow that it introduces are important.

Control of the initial focus of the laser beam, and elimination of the effect of disc profile, are provided by directly viewing the focused beam on the disc surface. This is accomplished by introducing a beam splitter (actually, a clear optical glass) above the microscope objective. Light scattered from the emulsion back through the objective is re-imaged onto a viewing screen. Control of the focused beam by mechanical translation of the objective is to nearly a micron. Direction of motion (up or down) is indicated by using a slightly off-axis beam in recording.

As indicated in Fig. 1, the laser beam after passing through the film is directed onto a silicon photodiode. For maximum flexibility this can be done with a small fiber optic, thus allowing a realtime monitoring of the modulated laser beam throughout the recording process.

The resulting master disc is shown in Fig. 3. This particular disc has a 33cm diameter; the disc itself has the physical properties of an ordinary sheet of negative black and white photographic film. It contains a continuous spiral video track with a  $2.7\mu$  center-to-center track spacing. The resulting playing time at the normal NTSC video framing rate is 20 minutes. Increases of playing time by a factor of two or three can be achieved by the layering of discs in the vertical direction. Playing time can also be increased by increasing the track density, or by the introduction of appropriate skip line or skip frame technique. In general, any of these means for significantly increasing the playing time requires additional sophistica-

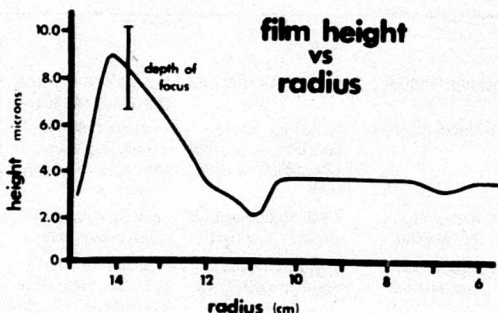

Figure 2. Variation in height of the film disc surface as a function of radius. Measurements were taken with the disc rotating at 1800 rpm, with the height at each radial point being an average for the disc circumference.

information Display: / Pa 5 7

tion in the playback device.

The film-based video disc as shown in Fig. 3 is impervious to normal handling hazards. It can be stored or shipped in a rolled or flat form. The information contained on the disc itself has all of the usual archival characteristics associated with photographic film recording. Minor environmentally induced imperfections (fingerprints, dust, scratches) are out of focus or are undetectable when high numerical apertures are used on replay. Major environmental insults are often tolerable due to the inherent redundancy in a typical video signal. In general, restoration of the disc even after extensive handling is easily achieved by use of ordinary film cleaner to eliminate foreign matter accumulated on the disc surfaces.

#### FILM DISC PLAYBACK

Replay of the film video disc can be accomplished by use of either a laser or an incandescent light source. Use of the laser provides a higher bandpass and increased signal to noise ratio, at the expense of the requirement for more sophisticated optical and electronic servo systems. Also, the introduction of the laser playback operated at its higher bandpass introduces coherent noise at the detector resulting from residual random film structure. However, careful optical alignment can produce a high quality video signal compatible with a standard television display. This is indicated in Fig. 4 (photo on front cover). Here the laser recorder is being used to replay a previously exposed and developed film disc. The original signal recorded on the disc was a full NTSC signal, derived from a normal commercial video broadcast ("Rhyme and Reason," W.T. Naud Productions). Visible in the foreground is the laser beam which is here being used to read the signal on the disc. The signal was recorded in the direct analog mode with pre-emphasis at the 3.58MHz sub-carrier frequency. The signal as presented on the standard 3-color monitor is derived directly from the amplitude modulation of the laser intensity by the analog pattern on the disc; the only signal processing involved in retrieval is the restoration of the chrominance time-base stability, to allow use of a non-critical, free-running rotation of the disc.

Many systems applications require a less critical configuration involving an incandescent light source rather than the coherent laser source. Fig. 5 shows a standard opto-mechanical design appropriate for use with an incandescent source. Playback device development has been directed towards maximum ease and maximum stability in use for such applications. Basic to this capability is the inherent flexibility of the non-contact optical read method, the utilization of an incandescent source for illumination, and the careful exploitation of the advantages of flying the disc in the floppy disc mode. Fig. 6 shows successful retrieval of video data from a video player which is being casually hand-held. Even the extreme environmental conditions depicted (non-stable mounting at an extreme angle) do not significantly alter retrieval quality. Operation of the video player is considerably more reliable than operation of an ordinary audio turntable.

An important system application indicated in Table I is the storage of file related data. This data can be text or pictorial in nature, or a combination of both. For example, an identification system based on a standard driver's license would be compatible with a simple monochrome data retrieval. Fig. 7 shows the retrieval of a single fixed video frame from a film disc. Here an incandescent source was used with detection effected by a silicon photodiode. The photodiode was operated with a proprietary non-nominal current sensing circuit to maximize the perceived signal to noise ratio.

This type of file material can easily be indexed, with each

frame on one disc or on a sequence of discs being tagged with a unique number in one of its vertical retrace intervals. (In Fig. 3, the vertical retrace intervals are visible as the wide radial bands some  $10^\circ$  in extent. These bands provide the vertical synchronization for the video signal. An embedded

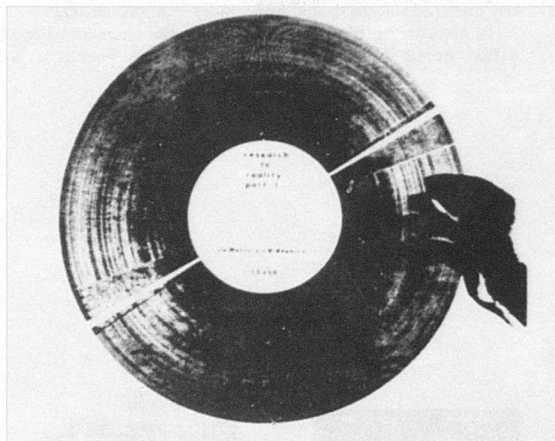

Figure 3. Appearance of the video film disc. This particular disc has a playing time in excess of 20 minutes at the full NTSC video framing rate.

indexing code in this interval would not appear on a standard television display.) Retrieval can be automated and carried out under either local or remote computer control. Under local control, a file number manually loaded into the external read register of a computer residing within the video player would initiate retrieval of the desired video frame. For more extensive systems, for example in the maintenance of financial or accounting file data, one video player may be interfaced to a large number of separate read terminals. One master com-

#### VIDEO DISC PLAYBACK UNIT

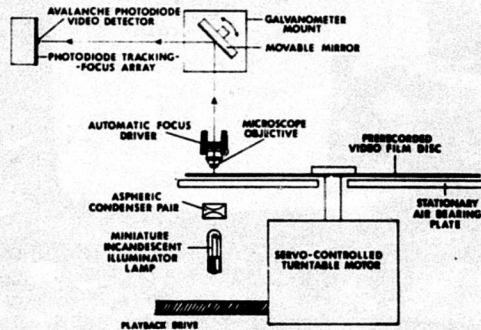

Figure 5. Optical/mechanical layout of the standard playback device which uses an incandescent source.

puter may then control access to the video file by establishing the appropriate queuing; system access time is minimized by buffering the file with a frame-grabbing capability. In this mode, the maximum access time to any frame on a disc from any one read station should be no more than one second.

In considering file data applications, the characteristics of a film stored data base must be recognized. That is, a file

which is continuously revised would more naturally be maintained as a magnetic stored data base. However, for those files for which file integrity is critical (such as financial files), or for those files for which only additions and not revisions are needed (generally called library files), a film-stored data base is a clear advantage.

Of the further systems applications listed in Table I, the use of the video disc medium as an instructional device is almost immediately obvious. This use can be carried out at several levels of sophistication. At the most primitive level, the video disc and player can be used as a simple training device. Physical actions and verbal instructions can be demonstrated and repeated in great detail either continuously or over and over, at the requirements of the viewer. The software material can be segmented into a programmed sequence, with progression through the sequence under viewer control. At the most advanced level of use of the disc medium, progression through the software would be under local computer control. The progression would be determined by interaction between the viewer and the computer: questions would be generated from the software material on the disc, and presented to the viewer at appropriate branch points. The viewer's responses would be weighed by the computer, and would be used to calculate subsequent program progression. Here it is important to note that many of these instructional applications would involve only very limited numbers of copies of discs on a given subject. It is in this situation that the ease of mastering and replication becomes the paramount consideration.

The final systems application in Table I is the use of the film based video disc as a read-only memory. In this area, the data storage capacity and the rate and the accuracy of the data retrieval are of primary importance. A typical full frame NTSC color video signal is equivalent to in excess of  $10^7$  bits per second; thus the video disc is capable of delivering data at a rate in excess of 10 megabit/sec. However the data accuracy is compatible with the normal highly redundant video display, and is of a lower quality than that generally required in many read-only memory applications. Increasing the accuracy to a level compatible with typical computer memory requirements entails considerable data redundancy in the form of error detection and correction codes. Also the requirements of data addressing on the disc form a significant overhead on the data storage capacity. As a result of these considerations, optical disc systems demonstrated to date show considerably less capability than the  $10^{12}$  bits/m<sup>2</sup> ( $10^{11}$  bits/disc) calculable attainable maximum with an optical read system.

Of course, if the contents of the read-only memory are data in the form of video images, the usual advantages of the optical video disc are available. A data store used in a refresh video display would be a natural application of the video disc; this type of system has been developed and is worthy of discussion in some detail. In the typical refresh application, the ability to switch rapidly from one video image to another is a considerable advantage. It is difficult to do this using a laser read-out from the disc. The laser beam must be pointed to a micron-sized spot and mechanically steered from one track to another by moving a mirror. This requirement of a physical motion introduces definite limitations on the switching rate and the maximum distance between tracks which may be covered during the switching time. Introduction of multiple laser readheads, each head with its own steering optics, is hardly practicable. In contrast, the use of an incandescent source for illumination, and the imaging of the disc surface back up to the detector(s) allows immediate access to all data tracks within the optical field of view. Further, with detection of one data track effected by a photodiode, an array of photo-

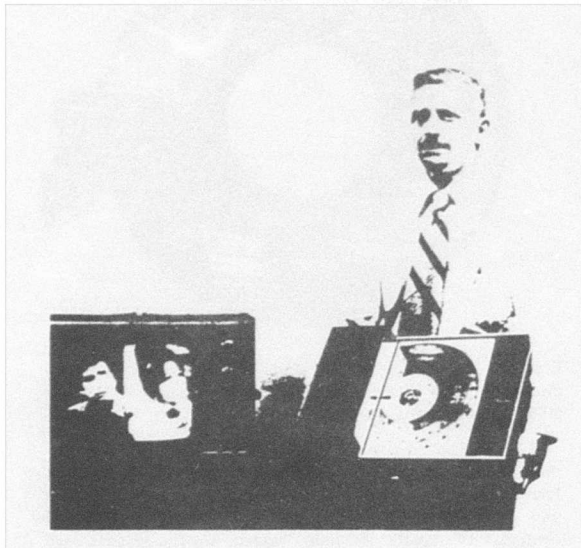

Figure 6. The video signal displayed is generated directly by the hand-held video player, demonstrating operation under environmental stress.

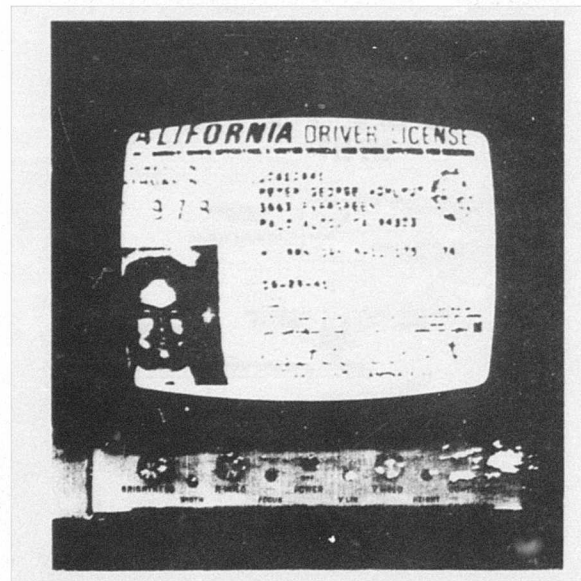
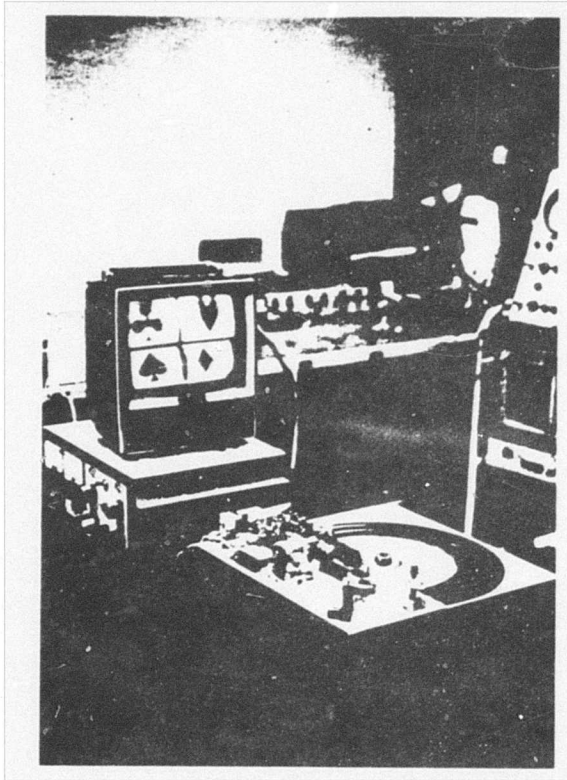

Figure 7. The video frame presented on the monitor is derived from a video player using a film disc and an incandescent source for illumination.

diodes provides a means of switching in a very short period of time ( $< 200\text{ns}$ ) between arbitrarily chosen tracks. There are no mechanical limitations on switching times, and configurations in which there is one readhead (that is, one photodiode) per track may easily be constructed.



**Figure 8.** The video frame presented on the monitor is constructed from four different data tracks on the disc. There is one read-head (photodiode) per track, with an electronic switch between tracks effected twice per line and twice per field.

One variant of this type of system results from the extremely short switching time available: the switching rate can be increased to exceed the 16kHz horizontal line rate by two orders of magnitude. As a result, one video field can be constructed from a number of distinct data tracks. Fig. 8 shows a replay in which each video field is constructed from an appropriately switched set of four photodiodes detecting four distinct data tracks. Each of the original data tracks generates a video image which consists of a set of four identical symbols (spades, hearts, clubs or diamonds) appearing in the four quadrants. The video image that results from the switching among the four data tracks shows a different symbol in each quadrant. The switching is carried out twice per line and twice per field; permuting the switching order permutes the symbols' positions. The switching is clocked by a fifth photodiode observing a timing track on the disc which is adjacent to the data tracks.

Manipulation of the video signal by track switching in this fashion is possible only with a light source imaging the data

tracks onto a solid state detector array. Also, this type of track switching offers the prospect of completely eliminating the requirement of mechanically following video tracks in the other systems applications described above. The switching rates required for solid state tracking are quite low ( $< 5\text{kHz}$ ) and the switch can take place in the horizontal retrace interval. Solid state tracking as used on an imaging optical system eliminates a major mechanical servo system and considerably improves the reliability of the video image retrieval.

#### ACKNOWLEDGEMENT

I wish to thank Noel Quigg for his assistance in recording the video discs used in illustrating this paper.

#### about the author



Jonathan A. Jerome is a Research Scientist with i/o Metrics Corporation, with primary responsibilities in the area of assessing and implementing the storage and retrieval of information from photographic film. He also serves as Vice-President for Videonics of Hawaii, Inc., conducting development of the film-based video disc system.

His academic background includes a Master's Degree in Physics from the University of Hawaii, with graduate work in the area of graphical data bases and their conversion to computer data bases.

Work experience prior to joining i/o Metrics/Videonics includes two years with Avco-Everett Research Laboratory evaluating and applying high resolution, astronomical video imaging and video tape storage systems.

ENCLOSURE 2

A Review of the MCA Disco-Vision System  
Kent D. Broadbent, MCA Disco-Vision, Inc.

# A Review of the MCA Disco-Vision system

Kent D. Broadbent  
MCA Disco-Vision System

The MCA Disco-Vision system can be considered in terms of three techniques:

1. Mastering
2. Replication
3. Playback

## 1. MASTERING

The recording medium is a thin metal film evaporated onto an optically polished plate glass disc 0.24" thick. Glass was chosen because it is very uniform and because its surface can be made smooth and free of scratches, pits and other blemishes by the well-known techniques of optical polishing. Starting with discs cut from twin-ground plate glass the surface may have hundreds of small pits per square millimeter. These discs are then reground with a fine abrasive to get rid of the deepest pits. Finally, the surface is optically polished until the pit density is reduced to less than 10 per square millimeter. The disc is then cleaned chemically and transferred to a vacuum evaporator where it receives a metallic coating a few hundred angstroms thick. For recording the disc is transferred to the mastering machine where a laser beam records picture and sound information by selectively melting the metallic coating.

The layout of a twenty-minute disc is shown in Fig. 1. The information track is a spiral of 2 micrometers pitch which is read from the outside in.

One TV frame is recorded per revolution of the disc. The information is recorded as a series of holes cut in the thin metal film deposited on the glass disc. The holes range in size from circles 1 micrometer in diameter at the 3" radius to ovals 1 micrometer x 2 micrometers long along the path at the outer radius. The recording has a mean wavelength of 3 micrometers.

Various techniques are available to lengthen the twenty-minute playing time of the described configuration. A forty-minute Disco-Vision record has been publicly demonstrated.

To minimize the cost of the processing electronics in the home player, the information on the disc is kept in the NTSC format required by the home TV set. The relative positions and frequencies of the video, chroma and sound subcarrier are preserved when going from the program signals to the signal represented by the holes in the disc coating; therefore, no

Page 12 / Information Display

re-formatting or re-arrangement of signal components are required in the player and minimization of the player cost is accomplished.

The choice was made to record with frequency modulation (FM) because of its immunity to noise at low frequencies where much of the system noise is. The usual source of audio and video signals is a 2" video tape recorder. The audio signal is used to frequency modulate a 4.5 MHz carrier. This carrier

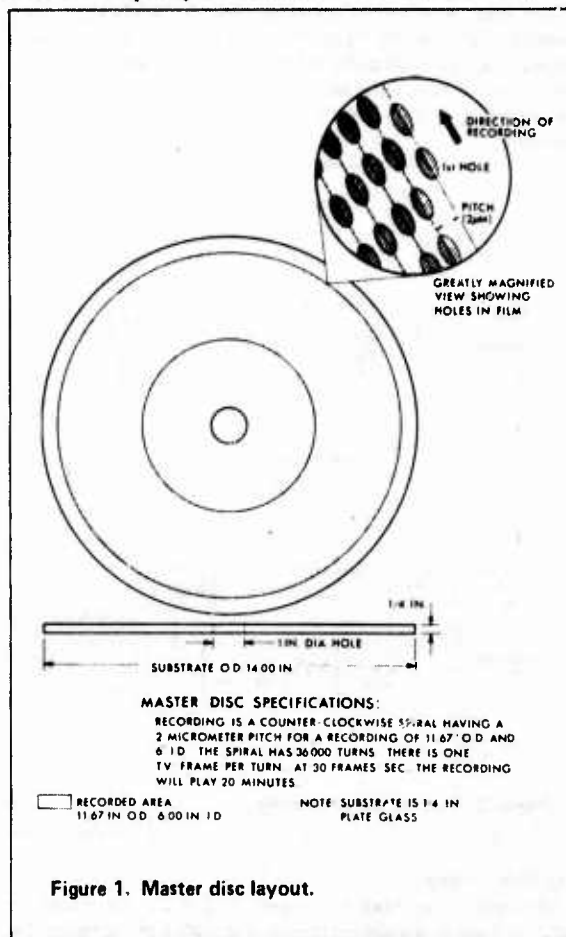

and the processed video are summed and fed to a voltage controlled oscillator (VCO). This device has a center frequency of approximately 7 MHz and a deviation of  $\pm 1$  MHz for a 1 volt peak-to-peak video signal. The recording polarity is such that sync tips produce the highest frequency, 8 MHz, and saturated whites produce the lowest frequency, 6 MHz.

Fig. 2 shows the basic signal processing used in mastering and playback. In mastering, the resulting FM signal occupying a spectrum from approximately 2.5 to 11.5 MHz, is applied by the cell driver to a Pockels cell electro-optical modulator. The Pockels cell has incident upon it the beam from the record laser. Under the influence of the signal from the cell driver, the Pockels cell alternately passes and blocks the beam, thus allowing the beam to produce holes and lands in the disc coating. An adjustable dc bias is applied to the Pockels cell to minimize 2nd-harmonic distortion that can be generated in the cutting process.

## Optical and Mechanical Techniques

Details of the physical arrangement required for cutting a master are shown in Fig. 3. An argon-ion laser produces the



basic "write" beam, which is modulated by the Pockels cell. Optics direct the beam onto the disc to produce the holes previously described. The rotatable Glan prism is used to adjust the average intensity of the beam reaching the disc. As shown in Fig. 3, the last few optical elements in the write beam are mounted on a carriage that is moved along the disc's radius by a motor-driven lead-screw. The objective lens is supported on an air bearing, which is loaded against the surface of the disc. A relatively small air flow at moderately high pressure maintains the head and objective lens at a constant distance of approximately 0.0005 inch (0.5 mil) from the surface of the disc. Fine focus adjustment is made by moving the diverging lens on the V block until optimum cutting is obtained.

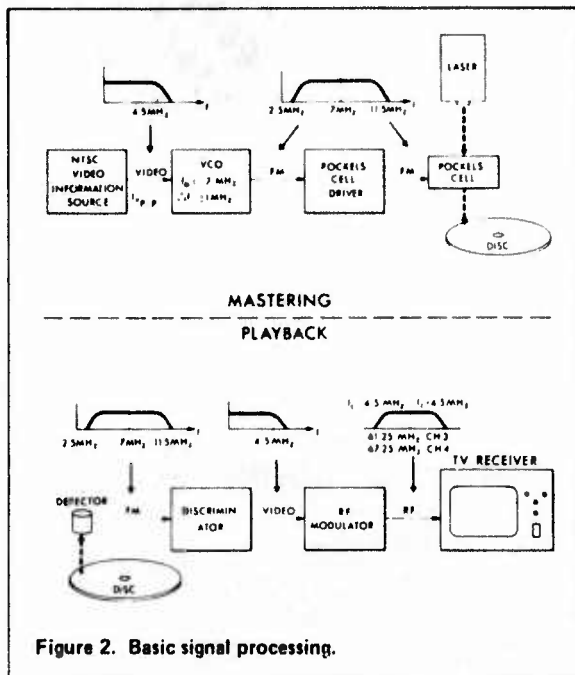

Figure 2. Basic signal processing.

**Read-While-Write**

Since there is no need to develop or process the master in order to read it, an optical system is included in the mastering configuration so that masters can be read while they are being cut. This feature allows the recording parameters to be adjusted while cutting and also provides continuous monitoring of the video quality of the master. Measurements of SNR and other video parameters can be completed and logged while mastering is in progress. Continuous monitoring also reveals defects in the master which could only be detected by playing it.

The optical arrangement consists of a 1 milliwatt He-Ne laser, a beam splitter, a second diverging lens, an adjustable mirror and an adjustable dichroic mirror for combining the read and write beams before they enter the microscope objective. The two adjustable mirrors are used to position the read spot about 10 micrometers down stream from the write spot and directly on the track it has just cut. The 10 micron spacing insures that the recorded surface is in its final state at the time it is read. The return beam comes out the same way it enters (the system is retro-reflective) until a portion of it is reflected into a PIN photodiode by the beam splitter. The diode, pre-amp and discriminator are all components of the playback system described later in this paper.

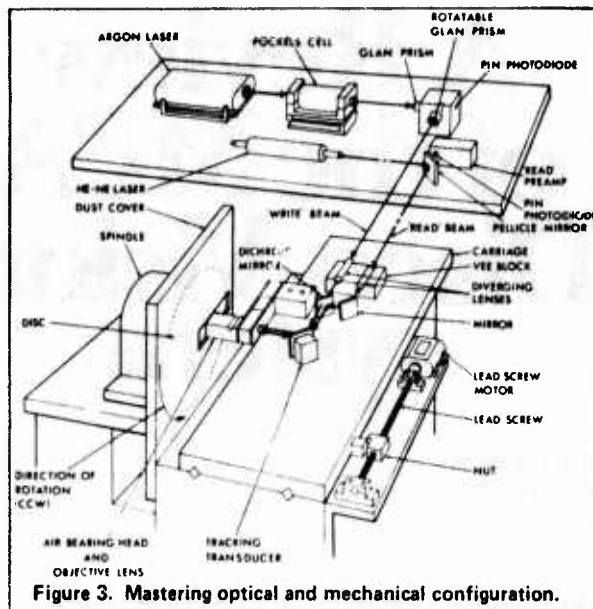

Figure 3. Mastering optical and mechanical configuration.

**2. REPLICATION**

After the master disc has been cut, it must be transformed into a configuration from which replicas can be made. This is done by transforming the essentially "two-dimensional" master record, which consists of holes in a thin metal film, into a "three-dimensional" configuration which can be used to stamp or form inexpensive, plastic replica discs.

**Master Transformation**

The master is coated with a photoresist material and is exposed through the rear (under-surface) of the disc. The ultraviolet light source exposes (polymerizes) the photoresist through the information holes. The uncut metal film shields the photoresist where there are no holes. This results in an array of hardened areas which coincide with the initial array of information holes. The unpolymerized photoresist material is then washed away with an appropriate solvent leaving bumps over the holes. Depending upon the photoresist used, the hardening program and other parameters, the height and profile of these bumps may be tailored to optimize the optical contrast between these bumps and the surrounding flat area when they are illuminated by the high numerical-aperture, diffraction limited optical scanning system of the player.

**Replica Forming**

The prime method of producing good quality, inexpensive replica discs uses a polyethylene terephthalate material and is a proprietary process at this time. It will be treated elsewhere when the patent circumstances and the proprietary elements permit. It has among its advantages a better quality, tougher record, a shorter production cycle-time, and web or automated belt handling of the entire disc replication process.

An alternate process which has also been employed involves treating the transformed master described above by electroless and electrodeposition to form a metal tool ("stamper") from which replicas are thermofomed, typically from polyvinylchloride by a method close to that used to make audio records.

**Post Forming Operations**

The plastic discs are finally metallized with a reflective coating and coated with a transparent plastic for protection against

degradation by handling. An alternate process to the final protective coating is to produce the discs using a transparent plastic permitting optical reading of the record through the transparent back side. Due to the limited depth of focus of the read-out optical system, typically  $\pm 1$  micron, scratches or dirt on the surface of the protective coating are out of focus and have no degrading effect on the record playback. Optically read records of this type actually require less care in handling than ordinary audio LPs.

The replicated discs are typically 5 to 10 mils in thickness and may be configured either with information bumps as indicated in the master transformation section or information holes made by forming these bumps into a mating surface—depending upon how many generations or reversals are involved between the transformed master and the final plastic replica. These two configurations are both satisfactory from an optical read-out standpoint.

### 3. PLAYBACK

The playback unit is self-contained and is designed to be connected to the antenna terminals of any domestic American color television receiver to provide playback of replicated videodiscs. It employs an optical technique to read the videodisc that does not require any physical contact between the read head and the videodisc. This non-contact system provides for long life of both the videodisc and the read head and it also permits freeze-framing without any wear penalties. The essential elements of the playback unit includes: (1) an optical system that directs and focuses a low-power helium-neon laser beam to a small read spot on the surface of the videodisc and then collects the reflected optical energy and directs it to a single photo-detector; (2) a means of rotating the videodisc at the correct speed; (3) a means of positioning the read spot on the videodisc surface which acquires and locks on to the spiral data track; (4) a means of maintaining the optical system in focus on the surface of the videodisc; (5) the necessary electronics to process the signals for the television receiver; (6) the controls, control electronics and power supplied to operate and power the unit; and (7) a functional and decorative enclosure to house the unit.

#### Optical System

The playback optical system is shown in Fig. 4. The laser tube has a nominal output power of 1 milliwatt which is single mode (TEM<sub>00</sub>) and linearly polarized. The laser beam is initially directed by two mirrors that are adjustable for alignment purposes. The laser beam is then expanded to fill the back of the objective lens by a plano-convex lens. This beam expanding lens is adjustable along its axis to provide for fine focus of the optical system. The beam is then transmitted through a specially coated beam splitter. The direction of the laser beam polarization is such that most of the beam will pass through the beam splitter. A quarter-wave plate changes the beam polarization from plane to circular. The beam is then directed into the back of the objective by two mirror transducers which consist of mirrors that can be rotated by piezoelectric bender motors. These rotations produce a corresponding motion of the read spot on the disc surface. One transducer is used to move the read spot in a radial direction to provide the high speed tracking corrections required to follow the data track. The other mirror transducer causes the read spot to move in a tangential direction on the videodisc to provide the time base corrections. These high speed tracking and time base corrections are required because of videodisc eccentricity, mechanical vibrations, etc.

Page 14 / Information Display

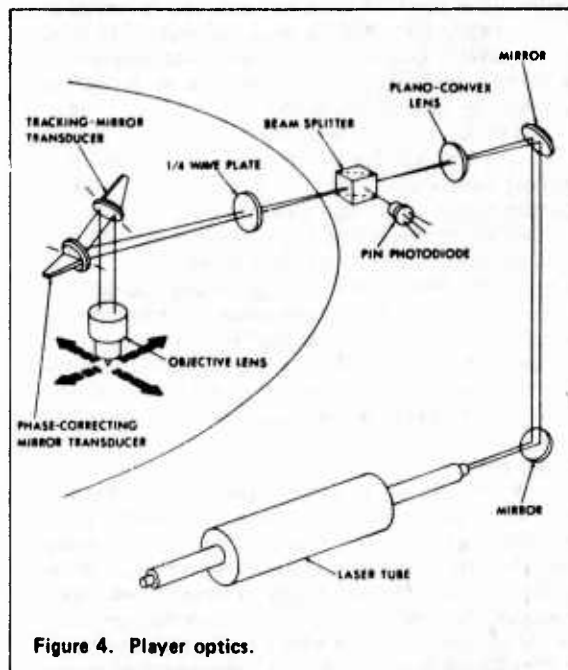

Figure 4. Player optics.

The objective lens which focuses the laser beam to a small spot on the surface of the videodisc has a numerical aperture of .35 and an effective focal length of approximately 12 millimeters. The laser light that is reflected from the surface of the videodisc is collected by the objective lens and returned along substantially the same path that the incoming beam traveled. When the reflected beam passes through the quarter-wave plate it is changed again to plane polarized light, but it is polarized at a right angle to the direction of the incoming laser beam. The reflected beam is then reflected by the beam splitter to the PIN photodiode detector where the optical signal is converted to an electrical signal for processing by the electronics. The use of the plane polarized laser tube, the specially coated beam splitter, and the quarter-wave plate results in a high efficiency optical system that minimizes the reflected signal that is fed back into the laser cavity.

#### Playback Signal-to-Noise Ratio

Measurements were made of the optical efficiency of the player by comparing the energy returned to the PIN diode by a large "land" area on a videodisc and a series of bumps having 2.2 micrometer wavelength, corresponding to an FM frequency of 6.75 MHz at a 3 inch radius. The return from the large land was 10.0%; from a bump 3.0%; from the space between bumps 5.5%. Hence, if a player with a 1 milliwatt laser was reading a 2.2 micrometer recording, a peak to peak signal of .025 milliwatt would return to the PIN diode. This in turn would yield a photocurrent of  $2 \times 10^{-6}$  amp RMS. The noise floor of such a system would be determined by photon shot effects, thermal effects, laser noise and pre-amp noise. Measurements indicate that the thermal and pre-amp noise dominate and are roughly equal. They give rise to a noise current of  $2 \times 10^{-8}$  amp RMS so that the FM SNR would be 100:1 or 40 db assuming perfectly recorded bumps having a 2.2 micrometer wavelength. When demodulated, this FM SNR yields a video SNR of better than 58 db which does not limit the playback quality. The actual playback video SNR is limited by replica disc quality and is presently better than 40 db.

### Disc Rotation

The videodisc is mounted on a turntable that is rotated at 1798.2 revolutions per minute by an electric motor. The speed of the turntable is sensed by a tachometer that consists of a phototransistor and light emitting diode that are located on either side of an incremental encoder disc that is mounted on the turntable spindle. The belt driven turntable spindle is powered by a universal type motor that is driven from the ac power lines using a triac. The triac is controlled by a phase locked loop control circuit that compares the tachometer output frequency with the counted down output of the 3.58 MHz crystal controlled oscillator in the signal processing electronics. Thus, the spindle drive motor is brought to and maintained at an angular velocity that produces zero mean error between the frequency produced by the tachometer wheel and that of the divided crystal oscillator. This is the rate required to make the frequency of the color signal, and hence the horizontal sync signal, within the range of the time base correction servo.

### Tracking Servo

Due to possible non-concentricity of the replicated disc and the turntable, replicated disc out-of-roundness and vibration, the read beam and the tracks relative positions do not remain constant. The tracking servo controls the radial position of the read beam in a manner that results in constant read beam position within the track. The ratio of opened to closed loop gain in the control loop would reduce a simple eccentricity of 0.1 millimeters to a reading error of less than 0.15 micrometers. The maximum trackable eccentricity is about 0.25 millimeters, but as a practical matter, the replicated discs will have eccentricities less than half that value.

Since the overall development objective was aimed at a reasonably priced consumer product, a simple tracking and information reading system requiring only a single photo-surface for all functions combined was developed (after considering a variety of techniques). This not only minimizes the cost of photo-detectors and their associated electronics, but even more importantly, reduces to one the number of optical paths that must be critically aligned and registered during the manufacturing process. The tracking servo technique is illustrated in Fig. 5. A single PIN photodiode is used to recover the tracking servo and video signals. A limited bandwidth, high gain dc pre-amp outputs a signal that is a function of read beam position within a track. It is clear that this signal is also directly proportional to laser power output. Since laser output power is influenced by a variety of conditions, some means of compensation is required for long term stable tracking. A portion of the direct beam is directed onto an inexpensive silicon solar cell with the cell output used as a compensating signal in the servo pre-amp, allowing the tracking servo to respond only to the read beam position within the track.

A dc bias, whose value represents position within the track, is summed with the pre-amp output and applied to the amplitude and phase compensation circuit which is designed to make the servo loop stable at high gain. The compensation deviates somewhat from normal control theory techniques because of the need to compensate the high Q of the piezoelectric mirror transducer that changes the radial position of the read beam. The output of the compensation circuit then is applied to the phase splitter which feeds the transducer drive amplifiers. When the loop is closed, the mirror transducer constantly positions the read spot with respect to the track so that the average reflected signal corresponds to the set dc bias.

There is a leadscrew drive system which moves the read head on a near radial path at the nominal pitch rate (2 micrometers/revolution). A secondary servo loop samples the low

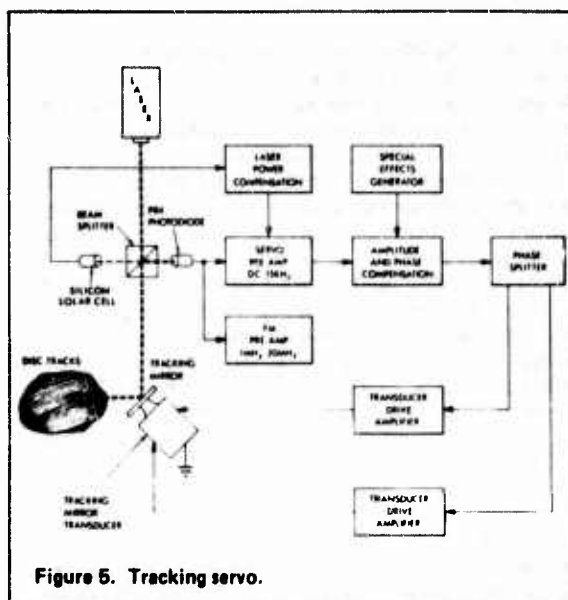

Figure 5. Tracking servo.

frequency portion of the servo signal to make the average head radius equal the read spot radius during playback.

To implement stop motion and other special effects a means of causing the read beam to "jump back" one track, at a predetermined time, is required. This is done by injecting into the tracking servo loop a modified impulse function with sufficient area to move the read beam one track (2 micrometers). Due to the dynamics of this process several compensating signals are also summed in the servo loop to keep the read beam positioned properly within the track immediately after "jump back."

### Time Base Correction Servo

In the normal television receiver the chrominance and horizontal sync circuits are very intolerant of time base errors in the composite video signal. To assure proper playback a corrective motion is applied to the read spot in the direction of the information track. The sources of time base error are the same as for the tracking error. The frequency of the burst signal is used as the basis of the control action. With the burst signal corrected all other portions of the video will be correct. The time base correction techniques is illustrated in Fig. 6.

The chrominance signal is extracted from the video and applied as one input to a phase detector. The other input is derived from a narrow range crystal VCO operating at the nominal color burst frequency. A zero order hold samples the phase detector output during the burst time-slot. Thus, the output signal has an amplitude proportional to the phase difference between the video burst signal and the VCO. This signal is then applied to an amplitude and phase compensation circuit (similar to the tracking servo) to stabilize the servo operation. The output of the compensation circuit is applied to a phase-splitter and then to the transducer drive amplifiers. The mirror transducer constantly positions the read beam such that the video burst frequency is exactly identical to the VCO.

Since the mirror transducer has finite dynamic range, static errors must be corrected by another technique. Another loop has been added to correct this problem. A signal containing the very low frequency components of the main servo loop is applied to the referenced VCO in a manner to cancel the static errors.

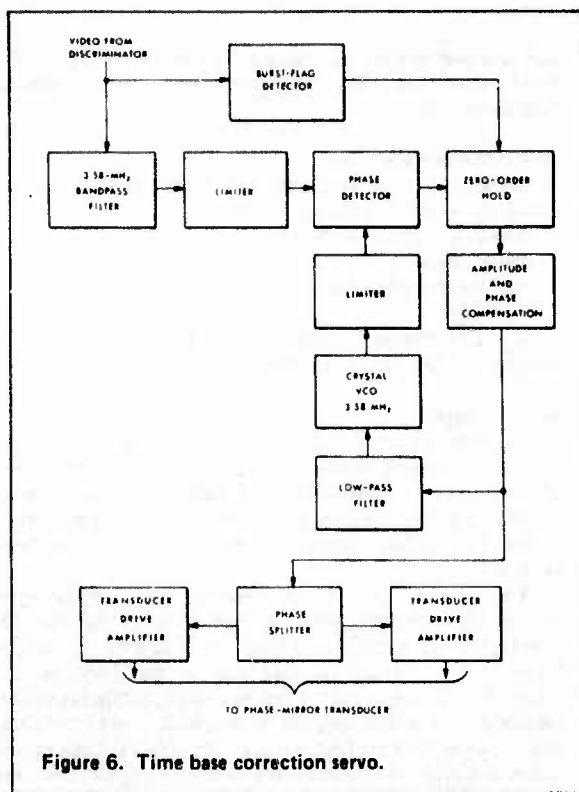

Figure 6. Time base correction servo.

### Reading Height Regulation

The videodisc is maintained at the focus of the optical system by means of a vacuum controlled aerodynamic reading head that carries the objective lens. The thin videodisc is separated from the turntable by a film of air when the turntable is rotating at speed. This film is due to the radial outward flow of air drawn through a circle of ventilating holes bored in the turntable just outside of the clamp ring. The air film decreases the coupling between the videodisc and the turntable enough to permit a vacuum applied to the face of the reading head to make a bulge in the surface of the thin videodisc.

The distance between the reading head and the surface of the videodisc is stabilized by the balance between the aerodynamic forces tending to push the disc away from the read head and the vacuum that tends to pull the disc toward the read head. The separation between the read head and the videodisc is controlled by vacuum pressure and air flow into the vacuum port on the read head. This fail-safe, vacuum controlled, aerodynamic reading head operates with a head-to-disc spacing of greater than 1 mil and provides stiff head-to-disc coupling that maintains the distance between the objective lens and the thin replicated videodisc to within 1 micrometer which is adequate to keep the optical system in focus.

### Discriminator and Drop-out Compensator

Because the FM encoded signal recorded on the disc is video in the NTSC format with the sound at 4.5 MHz, the signal processing electronics can be relatively simple. As shown in Fig. 7, the video signal is first recovered with a discriminator and then used to modulate an oscillator tuned to an unused TV channel. A more detailed description follows: The FM encoded information from the PIN photodiode is amplified by a wide band, low noise pre-amp located near the photodiode. The signal is limited and applied to the FM drop-out compensator.

Due to the nature of the Disco-Vision record and reproduce process, drop-outs tend to be caused by a missed half-cycle of the FM carrier. This requires a different compensation technique than that for systems such as magnetic tape where the duration of the drop-out is generally a large portion of a horizontal line. A missed half-cycle of carrier looks like a large decrease in instantaneous frequency so that the discriminator produces a whiter than white impulse in the video signal. If not compensated, the drop-out would produce a very distracting white spot in the TV image. To reduce the viewers awareness of the drop-out, the playback electronics includes an FM drop-out compensator which detects the missing half-cycle and synthesizes a signal to replace it. Although it contains no information, the synthetic pulse greatly reduces the visibility of the drop-out. This entire section, including the multiplying type of discriminator, is implemented with digital techniques for cost savings and ease of alignment.

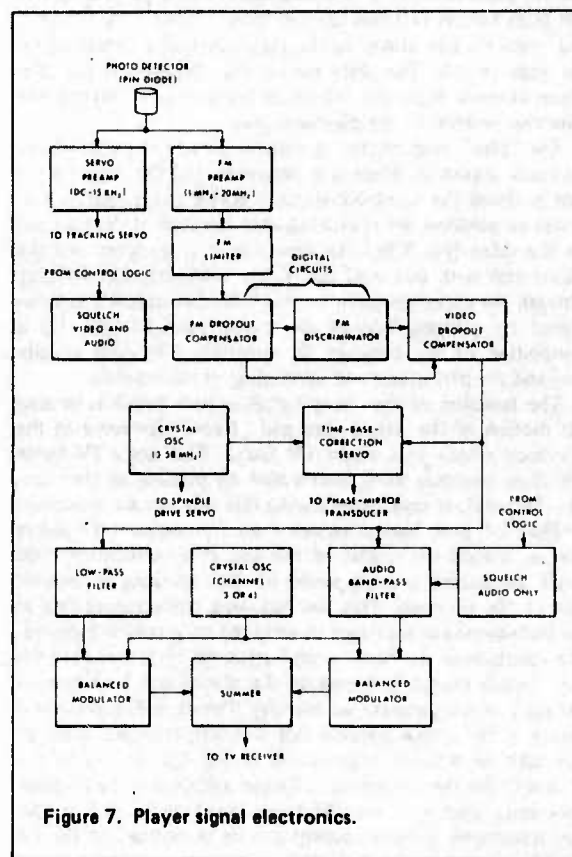

Figure 7. Player signal electronics.

On rare occasions drop-outs with a duration of several cycles of carrier are encountered. When this happens compensation is most easily done in the video domain. This is accomplished by passing the video signal through a zero order hold which operates normally in the sample mode. When a multiple cycle drop-out is detected, the circuit is switched to the hold mode. This supplies the last sampled value of luminance signal for the duration of the drop-out.

After discrimination what results is a full bandwidth NTSC composite signal complete with audio subcarrier.

The Disco-Vision recording and reproducing system, if not limited by the TV receiver, produces an image with more than 450 lines of horizontal resolution (on the basis of two lines of horizontal resolution per cycle of video signal) and video signal-to-noise ratio of greater than 40 db in the replica disc.

### R.E. Modulator

The R.F. modulator is illustrated in a portion of Fig. 2. The audio subcarrier and the video signals are separated by filters. Each is then applied as one input to a pair of balanced modulators. The other pair of inputs are derived from an oscillator tuned to the carrier frequency of the unused TV channel selected. The outputs of the modulators are then summed to form the RF signal for application to the antenna terminals of a TV receiver. A switching arrangement linked to the player power switch, connects normal TV antenna to the TV receiver when the player is not in use.

### Operating Controls

The operating controls for the playback unit are located in a control panel on the top front left corner of the unit. The control panel consists of a slide switch to turn the unit on and five push button switches labeled "play," "stop," "in," "out," and "reject". The power to the playback unit is turned on by the slide switch. The slide switch also disconnects the television antenna from the television receiver and connects the television receiver to the playback unit.

The "play" push button is used to initiate the start of the playback sequence. When it is depressed and the cover on the unit is closed the turntable starts to rotate and the player arm moves to position the read head over the start of the program on the video-disc. When the turntable is up to speed and the player arm is in position, the player will automatically play through the entire program on the videodisc unless it is interrupted by pushing one of the other push buttons. Upon completion of the program the turntable will automatically stop and the player arm will move clear of the videodisc.

The function of the "stop" push button switch is to stop the motion of the player arm and "freeze" the scene of the television screen to a single TV frame. This single TV frame will then continue until interrupted by pushing another button. The audio is suppressed during this stop motion sequence.

The "in" push button switch is used to translate the player arm in toward the center of the disc at approximately 100 times the normal playing speed for fast scanning to another part of the program. This fast scanning continues as long as the push button is depressed or until the program is completed. The function of the "out" push button switch is similar to the "in" switch except it translates the player arm back toward the start of the program on the disc. The optical, non-contact nature of the system permits fast scanning to be performed at will with no wear or degradation of the disc. It may be the ideal way for the consumer to locate a desired band for playback since even with the 100 times speed up in the fast scan arm translation, picture content can be recognized on the TV screen.

The function of the "reject" push button is to terminate the program and when depressed will stop the turntable and move the player arm clear of the videodisc.

### Special Effects and Applications

Because of the lack of physical contact inherent in this optical system and because information or frames within the disc may be random accessed very rapidly, many applications in addition to home entertainment are possible. These include archival storage of documents and facsimiles; audio-visual encyclopedias, dictionaries, catalogs, etc., that may be accessed immediately on a frame address basis; teaching machine and educational applications which involve inter-active programming with addressable sub-routines and branching and many other applications where data, pictures, motion or general audio-video information must be stored inexpensively

and accessed flexibly and rapidly. To this end initial work in frame numbering and coding and search programming has been carried out.

### Frame Number Encoding

This is accomplished by placing within each vertical interval a coded digital word containing the following:

- Pseudo Random Sync Words
- Parity Check
- Five Decimal Digit Frame Number
- Field I.D.

The information is coded in a self-clocking format to simplify the data recovery process.

### Search Program

The digitally encoded frame identification data is recovered with a self-clocking decoder. The data is stored in a buffer and updated every vertical interval. A parity check and pseudo random sync codes are used to ensure only valid data is used. A five digit display presents the number of the frame being viewed.

When the search mode is initiated, logic compares the present frame number with the desired frame number. The direction in which the desired frame lies is determined, and the leadscrew servo is set into fast scan in that direction. The digital data is read during the fast scan until passing the desired number. If the initial scan was in reverse, the leadscrew stops, and the player resumes normal real-time play until the desired frame is reached. If the initial scan was forward, the leadscrew reverses direction after passing the selected number and continues until the number is again passed. This places the read beam again ahead of the desired frame. The leadscrew again stops, and normal real-time play is resumed until the desired frame is reached. When the desired frame is reached, the logic switches to the stop motion mode where the desired frame can now be viewed. With the present player, this technique permits access to any frame out of about 36,000 within a few seconds. The search logic has the capability to perform other special effects. They are forward and reverse slow-motion (variable rate), and single-frame step forward and reverse.

### ACKNOWLEDGEMENT

The techniques reported in this review are the result of developments carried out by Department Heads John Winslow, James E. Elliott, and Ray Dakin, and their associates on the MCA Laboratories staff.

### about the author



Kent D. Broadbent, Vice President of MCA DISCO-VISION, Inc., is director of MCA'S videodisc research program. He is a specialist in the field of information storage and processing and his career as a research scientist and technical manager spans 21 years.

Prior to his affiliation with MCA, Mr. Broadbent was president of Broadbent Laboratories, Inc., and before that was director of American Systems, Inc.'s solid state division. Previously, he was head of the subsystems, components and devices section of Hughes Research Laboratories. He has also served as a technical consultant to Hughes Aircraft Company, North American Aviation, Lockheed Electronics and MCA Inc.

Mr. Broadbent has a B.S. in physics and mathematics from Brigham Young University and an M.S. in physics from Case Institute of Technology. He also completed extensive additional graduate work in physics and electronics.

Mr. Broadbent holds 18 patents and has published papers in technical journals on advanced information processing systems and solid state research.

ENCLOSURE 3

The Philips 'VLP' System  
K. Compaan and P. Kramer

*Edit. Note: In Philips Technical Review 33, No. 7 (published 18 October 1973) four articles have been published on the video long-play system (VLP), which has been developed at Philips Research Laboratories (Eindhoven, The Netherlands). The first of these four articles explains how the information is recorded on a Philips video long-play record and how it is scanned by the playing equipment. The other three articles are about signal processing during both recording and playback, the optical system used in the player and the control systems. These articles gave a picture of the state of development in the beginning of 1973. Of course in the meanwhile further progress has been made. — Drs. J. W. Miltenburg, Editor-in-Chief*

## The Philips 'VLP' system

K. Compaan and P. Kramer

Now that almost every home and many educational institutions have a television set it is natural to think of the possibility of using it, in combination with a playback unit, for reproducing programmes that have been permanently recorded in some way or another. This gives the user the freedom of being able to watch a programme he is interested in at a time convenient to himself — the same freedom he can enjoy with a shelf of books or a collection of gramophone records.

The 'VLP' system [1] described here allows a colour-television programme of about 30 minutes duration to be reproduced from a recording on a 'gramophone record' 30 cm in diameter, the usual size for a long-playing record. The 'VLP' record can be produced simply and in quantity by the normal pressing techniques. The 'VLP' system is complementary to the video cassette recorder (VCR), which has been on the market for some time, but to some extent it offers an alternative to it. A programme can be recorded as desired with a cassette recorder, but it is more expensive to produce recorded tapes than it is to press 'VLP' records.

The development of the 'VLP' system is the result of the combined efforts of a team of specialists in very divergent fields. In this article we shall give a broad general survey of the system; the three short articles that follow will describe some of the components in more detail [1] [2] [3].

The information is recorded on the record disc along a spiral track, which occupies the part of the disc between the 10 cm and 30 cm diameters. The speed at which the disc rotates has been made equal to the picture frequency,  $25\text{ s}^{-1}$  for the European market and  $30\text{ s}^{-1}$  for North America. As we shall see later, this offers some interesting possibilities. If the playing time is half an hour, these figures give a pitch of  $2\text{ }\mu\text{m}$  for the track.

For following a track with such a small pitch an optical method is very suitable. In the 'VLP' player this scanning is done with a spot of light  $1\text{--}2\text{ }\mu\text{m}$  in diameter, projected on to the track by a lens.

The diameter of the spot is of the same order of magnitude as the wavelength of the light used in the equipment, and it is therefore no longer possible to speak of a particular diameter. A diffraction pattern (an Airy disc) is formed at the focal plane of

the lens; this pattern consists of a central maximum surrounded by successive dark and light rings. To produce a pattern in which the half-intensity diameter is  $0.9$  to  $1.0\text{ }\mu\text{m}$  at the wavelength used, a lens with a numerical aperture of  $0.4$  is required.

The information for the reproduction of a television picture is recorded as a succession of short grooves or pits of variable length and repetition frequency. The width of the pits is  $0.8\text{ }\mu\text{m}$ , and the depth  $0.16\text{ }\mu\text{m}$  (see the title photograph). Since in pressing a gramophone record the surface roughness does not amount to more than  $0.01\text{ }\mu\text{m}$ , it is clearly a practical possibility to make such a pattern in the surface of a pressed disc.

If the spot of light falls on the surface of the disc between two of the pits, then most of the light will be reflected back into the objective lens. If on the other hand the spot falls on one of the pits, the light will be deflected by diffraction at the pit in such a way that most of it is not returned to the objective (fig. 1). In this way the intensity of the light reflected through the aperture of the lens is modulated by the pattern of pits [1]. The intensity variations are converted into an electrical signal by a photodiode. The width and depth of the pits in the surface are arranged to give as large a modulation depth as possible.

To obtain a high signal-to-noise ratio in the detector signal, the reflected beam should have as high an intensity as possible. If the photocurrent is too low, the noise will no longer be mainly determined by the thermal noise in the detector, but by the shot noise in the photon current. We have therefore used an He-Ne laser as the light source. Also, to improve the reflectivity, the surface of the 'VLP' disc has been coated with a thin layer of evaporated metal.

Some of the members of our team have developed a special technology that enables the He-Ne laser to be manufactured in quantity. This  $1\text{ mW}$  laser has been built into the player in such a way that it can be of no possible danger to the user.

The information on the surface of the disc can be read out through a transparent protective layer. Any contamination or damage only affects the outer surface of this layer, and not the disc. The diameter of the beam at this outer surface is much larger than the spot, so that these imperfections have very little effect on the detector signal. This arrangement makes use of the

*Drs K. Compaan is with the Philips Electro-Acoustics Division (ELA), Eindhoven; Dr P. Kramer is with Philips Research Laboratories, Eindhoven.*

very small depth of focus of an objective lens with a resolving power in the micron range.

To enable it to be encoded in the pattern of pits, the video signal undergoes a number of special processes<sup>[2]</sup>. The bandwidths of the brightness signal and the colour signal are both limited to some extent. The frequency of the colour-signal subcarrier, which is 4.43 MHz in the PAL system, is reduced to a value of 1 MHz, fixed with respect to the line frequency. This allows the original carrier frequency to be restored when the record is played, even if there are deviations caused by variations in the speed of revolution. The sound is treated as a frequency modulation of a 250 kHz carrier. The brightness signal, which modulates a 4.75 MHz carrier, determines the *repetition frequency* and the *average length* of the pits, while the preprocessed colour and sound signals give a *modulation of the length* of the pits.

Work has also been done on other encoding systems whose potentialities include the recording of a video signal with a wider bandwidth.

The master record from which the moulds are produced for pressing the 'VLP' records is cut by a laser in the specially prepared surface of a glass disc. This cutting is done at the same speed at which the records

will be played. A scene can therefore be recorded on the record directly from the video camera or transferred without delay from a magnetic tape. The moulds are made in the usual way from the master by an electroplating process.

If a 'VLP' player is to give good results four special requirements have to be satisfied. In the first place, the speed of revolution of the record must be kept constant to an accuracy of 1 in 10<sup>3</sup>, or the playback of the video signal will be unsatisfactory.

Secondly, the objective must remain focused on the surface of the record. Because of its large aperture the objective has only a very small depth of focus. Although the irregularities on the surface of the record are locally very small, the deviations over a wider area can be as much as 0.5 mm.

In the third place the beam of light must remain centred on the track, even though the track may be not truly circular (out-of-round) or eccentric. Deformation of the disc during pressing can lead to out-of-roundness; eccentricity of the spindle-hole in the record and play between it and the shaft of the playback unit can cause the track to rotate eccentrically. The player must be able to operate correctly even when the total deviation of the track from the ideal position is as much as 0.1 mm.

Finally, the complete optical system must move radially across the record at the rate at which the track advances ('tracking'), without the aid of a continuous groove or other mechanical guide in the disc or the player. To meet these requirements a number of control systems have been developed; these will be described in one of the following articles<sup>[3]</sup>.

Fig. 2 shows a diagram of the 'VLP' player. The complete pick-up unit can move backwards and forwards on a carriage on rails underneath the record disc 1 to follow the track. The light from the laser 2 is focused at the record by the objective 3. The control systems mentioned above act on the objective and a pivoting mirror 4, thus keeping the beam focused and centred on the track. A prism 5 ensures that light reflected by the record falls on the detector 6.

The 'VLP' player can also be used to show the pictures in reverse motion, slow motion or at higher speed. This is possible because the record rotates synchronously with the picture frequency — 25 rps for the European version, 30 rps for the American one. Consequently at each rotation of the track the field-synchronizing pulses always fall within two fixed diametrically opposite sections of the record disc.

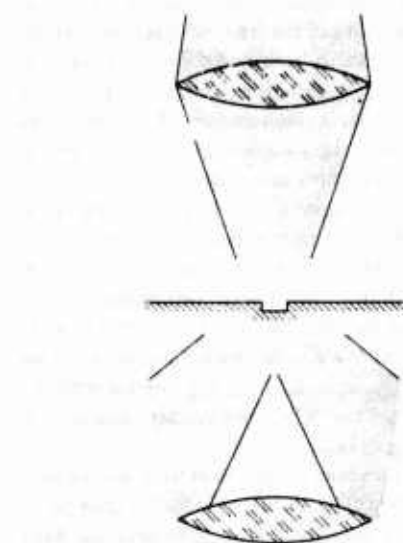

Fig. 1. Modulation of the light by a pit in the surface of a 'VLP' record. For clarity the system is drawn as if the record were transparent, with the beam incident from above and a second lens placed underneath the record to receive the light. The pit is also shown many times enlarged with respect to the rest of the figure. If the record surface is flat, all of the incident light is received by the lower lens. If there is a pit in the surface there will be diffraction, and some of the light will be deflected; when the pit is correctly dimensioned much of the incident light will be deflected away from the aperture of the lower lens. In practice the record surface is reflecting, and only one lens is required for concentrating the light on to the record and receiving the reflected light.

<sup>[2]</sup> Trade Mark, property of N.V. Philips' Gloeilampenfabrieken.

<sup>[1]</sup> G. Bouwhuis and P. Burgstede, this issue, p. 186.

<sup>[2]</sup> W. van den Bussche, A. H. Hoogendijk and J. H. Wessels, this issue, p. 181.

<sup>[3]</sup> P. J. M. Janssen and P. E. Day, this issue, p. 190.



(A television picture consists of two interlaced fields.) Wherever the spiral track crosses the two sectors it therefore contains the same information — the field-synchronizing signal. This means that inside the sector the beam can be allowed to change from one turn of the

turns. This will give a 'picture-book' of about 45 000 different pictures. Address coding allows any particular picture to be found rapidly.

The large number of pictures — which can be completely different if desired — that can be stored on the

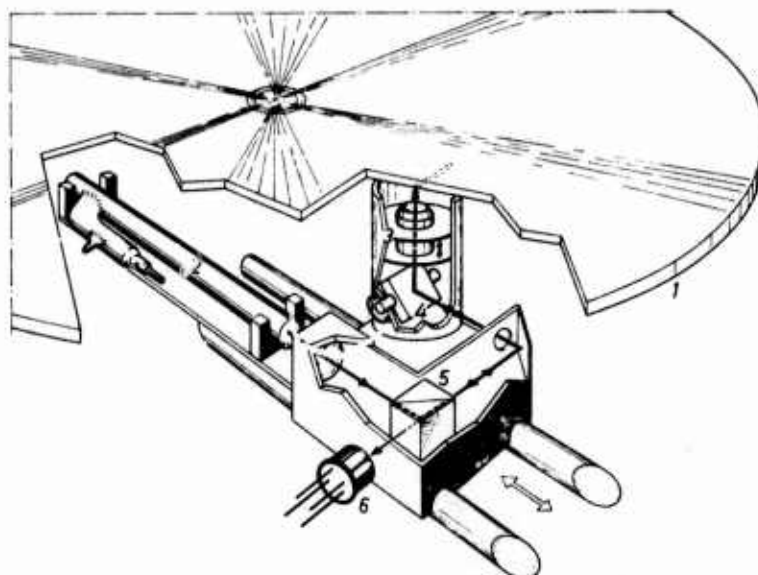

Fig. 2. Schematic diagram of the 'VLP' playback unit. The record 1 is scanned from below by light from the He-Ne laser 2. The objective 3 is held focused on the record by a system based on a loudspeaker mechanism. The pivoting mirror 4 ensures that the beam remains centred on the track; the mirror is operated by a rotating-coil arrangement. Incident and reflected light are separated by the prism 5. The detector 6 converts the reflected light into an electrical signal.

track to an adjacent one, without spoiling the picture. This is done by applying a control pulse at the correct moment to the control system for correct centring on the track. By continually repeating the same turn and thus the same picture in this way, a stationary picture will be obtained. By repeating each picture twice a picture in slower motion will be obtained, and by omitting every other picture the action of the scene will be reproduced at twice the speed. A picture in reverse motion is obtained by jumping back a turn at each half revolution.

Because of the accurate centring of the scanning beam on the track the cross-talk between successive turns is very small ( $< -30$  dB), so that it is possible to record completely different pictures on successive

'VLP' record, and the scope for manipulation of the recorded information, make the 'VLP' system one that clearly offers more than the simple dissemination of video information.

**Summary** Television pictures are recorded on the Philips video long-playing ('VLP') record in a spiral track of pits in the surface. The pits have constant width and depth but the lengths and spacings are variable. The information is read out by a beam of light, which is reflected at the surface of the record. The reflected beam is modulated by deflection of the light through diffraction at the pits. To enable the 'VLP' playback unit to operate at the required accuracy, control systems have been developed for holding the speed of rotation of the record constant, focusing the read-out beam on the record surface and centring the beam on the spiral track without the assistance of mechanical guides. The player can be used to show the recorded pictures one at a time, and will also allow them to be shown in reverse motion, slow motion, or at faster speed.

ENCLOSURE 4

An Experimental Optical Videodisc Playback System  
George W. Hrbek, Zenith Radio Corp.

# An Experimental Optical Videodisc Playback System

By GEORGE W. HRBEK

An experimental videodisc playback system has been developed using a thin flexible transparent plastic disc as the information carrying medium. The information is read out by transmitting HeNe laser light through the disc. Information is stored on the disc in the form of pitted tracks or hill-and-dale modulated grooves. The player has a simple optical path and servo system. A magnetically driven two-axis mirror controls the light beam independently in the radial and tangential directions, providing excellent radial tracking and time-base correction. Vertical focusing of the light beam is maintained by aerodynamic stabilization of the disc. A high-frequency carrier is frequency modulated with the chroma and luminance information. Luminance bandwidth is equal to that normally used in NTSC receivers. Tentatively, the sound has been put on its own FM carrier at a low frequency. A transcoder converts the disc signal into an NTSC signal on a VHF carrier. Because the disc is transmissive, both sides can be played without crosstalk merely by adjusting the focal plane of the laser light spot; the disc itself need not be repositioned. Track spacings as close as 9,000 tracks/cm (0.39 in), corresponding to a playing time of 4 min 43 s/cm, have been achieved experimentally with acceptable crosstalk between tracks.

## Components of the System

### The Flexible Disc

Most of our experimental work has been done with thin flexible clear polyvinyl chloride (PVC) discs about 6 mils (0.15 mm) thick. Diameters range from 8 in to 12 in (203 to 305 mm), with a typical groove or track density of about 400 per millimeter. The discs are made by pressing of PVC film. An electron micrograph of such a disc is shown in Fig. 1. The tracks are separated by about 2.5  $\mu$ m center-to-center. The pits are about 0.3  $\mu$ m deep (about 1/500 of the thickness of the disc) and about 0.7  $\mu$ m wide. Their length varies from about 1  $\mu$ m on the inside tracks to about 2  $\mu$ m on the outside. The photograph was made of a disc stamped from a master recorded at 33 1/3 r/min (1/54 real time) utilizing a blue HeCd<sup>+</sup> laser. We have recently been successful in recording in real time at 1,800 r/min.

### Optics

Figure 2 shows a diagram of the optical system used to read out the transmissive disc. A 1-mW HeNe laser provides the 6328- $\text{\AA}$  light which is first focused by a simple intermediate lens and then allowed to illuminate a servo-controlled mirror. The final lens has a field 250  $\mu$ m wide, which allows the mirror to correct over the necessary range. The numerical aperture of the final lens is 0.4. Based on these figures, it can be determined that the diffraction-limited spot size on the record will be less than 1  $\mu$ m and as we shall see this gives us low crosstalk between channels while it requires very accurate vertical focusing control. A

Presented on 26 April 1974 at the Society's Technical Conference in Los Angeles by George W. Hrbek, Zenith Radic Corp., 6001 W. Dickens Ave., Chicago, IL 60639.

(This paper was received on 28 May 1974.)

split photodiode under the record provides the radial tracking error signal and RF output for the video and time base correction.

## Principles of the System

### Radial Tracking

To make clear how the system consisting of the laser, the pitted disc and the split photodiode actually operates, it is best to consider a hypothetical disc with V-shaped grooves rather than rectangular pits. In this case it is easy to see that if the light beam strikes the groove off-center, more light will be refracted on one side of the groove than at the other. Being refracted, it is directed away from the vertical (toward the normal to the

slanted surface). After becoming completely defocused, it passes out of the disc where more of it is detected by one half of the split photodiode than by the other. Because of the unequal distribution of power between the two photodiode parts, a difference amplifier can produce an error signal to drive the radial tracking servo. The servo repositions the moveable mirror to correct the lateral position of the light spot.

How does this principle work with a pitted record? Figure 3 shows how the beam is split to create the same radial error information. Tilted phase fronts are created in the disc if the light beam is not centered over the pit. If the pits are  $\lambda/[4(n-1)]$  deep, where  $\lambda$  is the wavelength of the laser light (6328  $\text{\AA}$ ) and  $n$  is the index of refraction of polyvinyl chloride (1.54), the path difference between air (inside the pit) and plastic (outside the pit) becomes 90°. This is an optimum condition, producing a maximum difference in illumination between the two photocell parts. Pits of this 0.3- $\mu$ m depth can be tracked just like a V-groove.

### RF Output

The sequence of pits constitutes half cycles of an RF carrier which is frequency-modulated by the video information. Passage of the pits through the focused light beam causes a periodic change in the direction of the transmitted light along the direction of the track.

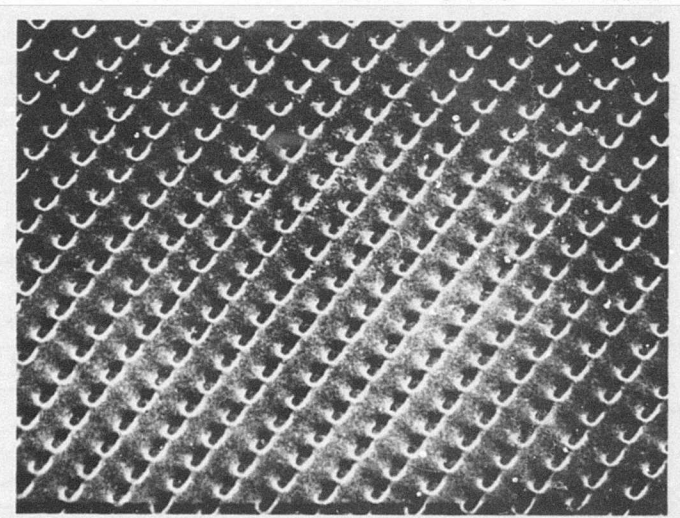

Fig. 1. Electron micrograph (2,700  $\times$ ) of optically recorded, 400 lines/mm transmissive videodisc.

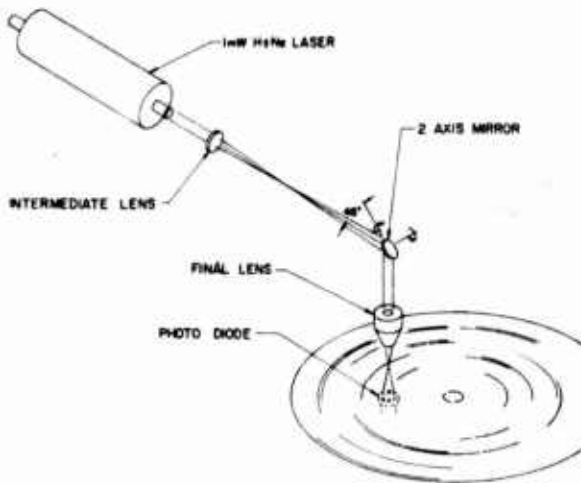

Fig. 2. Player optical system (transmissive).

Figure 4 shows how this is picked up by a photodiode which is offset from the center position of the beam. We have also used two diodes arranged in push-pull along the track.

*Time-Base Correction*

A disc usually has distortions which are physically impressed in the record during manufacturing. Unavoidably, it is somewhat eccentric, and there are also variations in the speed of the spindle. These defects introduce timing errors into the video output of the photodiodes. These must be corrected to produce good pictures on a conventional receiver. Figure 5 shows some of the record distortions we

have observed. The dashed track shows a perfect track mounted on its true center. Assuming constant angular velocity, the tangential speed of all points on the perfect track will be equal because they are at a constant radius  $r$  from the center.

Eccentricity of the record is caused by locating the center hole imperfectly (displaced  $Z$  axis). Four-axis distortion is caused by noncircular grooves (displaced  $X$  and  $Y$  axes). Both these effects are shown in Fig. 5. Here  $r'$  varies with rotation causing variations in the tangential speed.

Figure 6 is a block diagram illustrating the tangential mirror and spin motor control systems. A tachometer-controlled

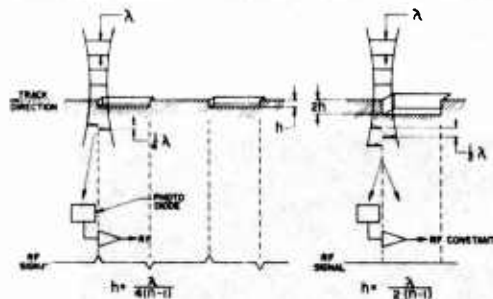

Fig. 4. RF signal derived from pitted tracks.

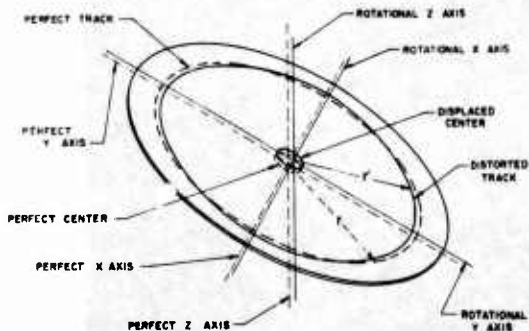

Fig. 5. Videodisc distortions (sources of tangential timing error).

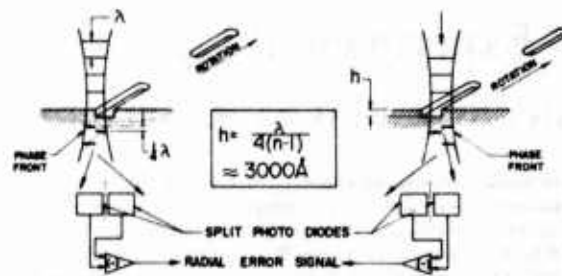

Fig. 3. Radial tracking with pitted tracks.

dc motor servo loop provides speed control sufficient to handle expected line voltage and motor load variations. The tangential mirror servo (the same as the radial tracking servo, but using two different coils) is controlled from an error signal generated at the output of an FM discriminator tuned to a pilot carrier which is recorded on the disc. We have found this easier than extracting the error signal from the horizontal sync pulses. Photographs of TV pictures with and without time-base correction are shown in Fig. 7.

*Vertical Control*

Laser light allows low crosstalk between closely adjacent tracks because a very small spot size can be achieved, subject only to the diffraction limit. Along with the advantage of a small spot size, we may use virtually all the light, which means that the optical SNR can be practically unlimited.

Using such a small spot size requires us to manage with a very small depth of field in such a system on the order of  $3.1 \mu\text{m}$ . To achieve this accuracy of vertical control, we have employed an aerodynamic stabilizing system developed by Thomson-CSF Research Laboratories (Fig. 8). The flexible disc "flies" close to two dihedral surfaces and takes on the shape of the surfaces. The disc then enters the jaws of the vertical stabilizer which keeps the upper surface of the disc stable to within about  $3 \mu\text{m}$ . This is

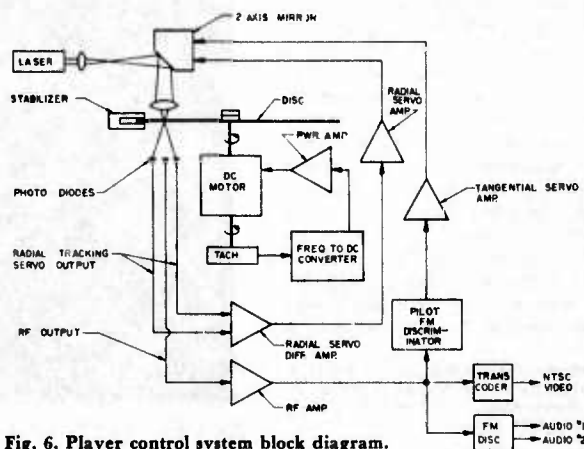

Fig. 6. Player control system block diagram.

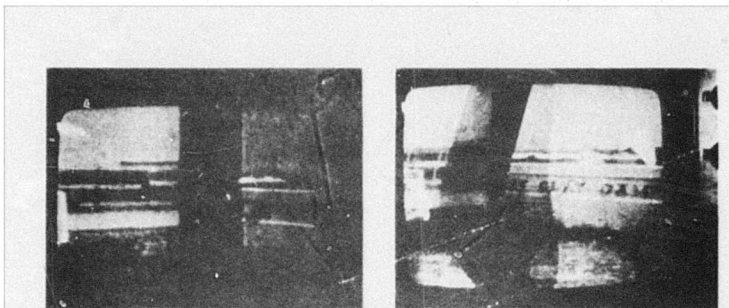

Fig. 7. Television pictures showing effects of tangential time-base correction, with set externally synchronized. Left: time-base correction added; right: no time-base correction.

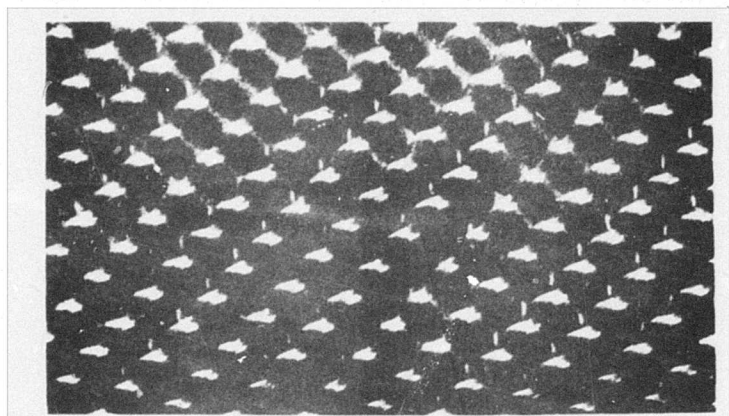

Fig. 9. Electron micrograph (2,700 X) of mechanically recorded transmissive videodisc.

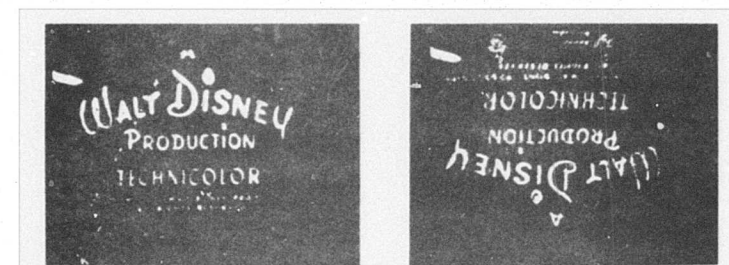

Fig. 10. Television pictures played from opposite sides of a transmissive videodisc, (left) beam focused on upper surface; (right) beam focused through disc on lower surface.

achieved by the pressure of the air entrained by the disc and forced into the narrow space within the stabilizer. Because a flexible record had been our goal all along, we have used this system extensively in our experimental work. It eliminates the need for a vertical focus servo while permitting the use of a simple low-cost record.

#### Signal Processing With a Transcoder

We have used an FM carrier which never drops lower than twice the highest frequency, thus avoiding many intermodulation problems. The only signals which we have tentatively placed into the baseband (below the highest video fre-

quency) are a sound channel and the pilot carrier for the time-base correction. There is plenty of space for extra sound channels. A transcoder, not unlike those used in videotape equipment, removes the frequency fluctuations from the signal and transfers the chroma to a crystal-controlled 3.58-MHz subcarrier. We are experimenting with alternative signal encoding systems, particularly with a view toward reducing transcoder cost.

#### Operation of the Experimental System

The optical system described can play mechanically cut, hill-and-dale grooved records as shown in Fig. 9. We have cut

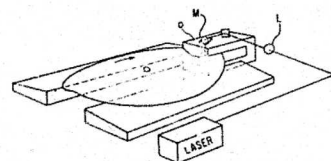

Fig. 8. Aerodynamic stabilizer developed by Thomson-CSF.

discs with mechanical wavelengths of less than  $1 \mu\text{m}$ , and this allowed us to get started long before we were able to record discs optically.

We have successfully pressed a 6-mil (0.15 mm) disc on both sides and are able to play it without turning the record over. This is shown in Fig. 10. Crosstalk between the two sides is not noticeable because — as we have seen — the beam is completely out of focus during its passage through the unused surface. One must record the opposite side backwards, but this should be no problem.

As a consequence of our excellent radial tracking system and the low crosstalk between adjacent tracks, we have been able to make and play back records with up to 9,000 tracks/cm (0.39 in). Playing times of about 45 min on one side of a 12-in (30½-cm) record are achievable with the increased density. Coupling this with dual-sided recording, 90 min of play may be possible on a single disc.

#### Conclusion

The system just described has many advantages. First, the transparent, flexible disc is simple and inexpensive and requires no additional processing after stamping. Our stamping yield has been excellent. The optical system is also rather simple, including the lens. There is only a single servomotor. No vertical focusing servo is required. It is possible to play both sides of the record, but even on one side the high density of tracks permits long playing time.

The system also has its weak points. The flexible disc is easily damaged. Fingerprints are a problem. Clearly, some sort of protection is desirable. The aerodynamic stabilizer does an excellent job with flat discs but has trouble coping with warped discs. I believe that further work will overcome these difficulties.

Of course, I should mention that this system makes beautiful pictures. When we consider also the simplicity of disc and player and the advantages that all optical systems share, we have to conclude that the approach seems worth pursuing.

**Acknowledgment:** The experimental work reported here was done in close cooperation with the Thomson-CSF Research Laboratories in Corb eville, France, and it should be emphasized that their contribution was by no means limited to the aerodynamic stabilizer.

ENCLOSURE 5

The RCA "SelectaVision" VideoDisc System  
Corporate Paper

# The RCA "SelectaVision" VideoDisc System

The RCA "SelectaVision" VideoDisc has been developed to satisfy the need for a pre-recorded video storage and playback system suitable for the home environment. To be suitable for the consumer market, such a system must be reliable, easy to operate, provide a high quality color picture on a standard color TV receiver, have a wide selection of program material, and be low in cost. The RCA VideoDisc system has these qualities. The techniques by which they are achieved are discussed in the following paragraphs.

Three key design decisions led to the simplicity and low cost of the RCA approach:

1. *The use of a grooved disc to permit the disc itself to provide positive tracking of a stylus along the signal path by purely mechanical means, eliminating the need for any expensive servo loops.*

2. *The use of capacitance pickup from a metallic electrode deposited on the stylus to retrieve the signal. The advantage here is that the stylus is easy and inexpensive to fabricate in comparison to any other technique for retrieving recorded signals from the disc. (The capacitance pickup is capable of resolving signal elements smaller than the wavelength of visible light, permitting RCA to take full advantage of the high density recording capability of the electron beam recording technique RCA has developed.)*

3. *The choice of a lower rotational speed of 450 rpm. Important advantages are: Problems of vibration due to unbalance of the disc or rotating parts of the player are significantly reduced in their effects. Errors in signal timing that might result from warp or eccentricities of the disc occur at a frequency that is easier for the television receiver to compensate for. More importantly, a simple and inexpensive electromechanical device, the "arm stretcher," can be used at this lower rotational speed to reduce time-base errors thereby permitting playback into receivers with the relatively slow horizontal synchronizing circuits typical of most U.S. and European made receivers, without requiring modification of those receivers. A disadvantage is that*

Page 20 / Information Display

*there are 4 TV frames recorded during each revolution of the disc, making it less suitable for stop-action and slow-motion effects.*

With the exception of the stylus, the RCA VideoDisc player is fabricated almost completely from conventional and familiar components of types that have been in production for many years in consumer products. As indicated above, the use of a grooved disc and capacitance pickup stylus contributes greatly to the simplicity and low cost of the RCA VideoDisc system. An obvious question is "What is the playing life of the disc and the stylus?" The discs have routinely exhibited playing life in excess of 500 plays before visible signal degradation. The life of the sapphire stylus is expected to be 300 to 500 hours of playing time. The stylus and stylus arm are housed in an inexpensive cartridge, easily replaceable by the user in the home.

In a new medium for entertainment and self-education, long playing time per disc is an important consideration. Each RCA disc is capable of reproducing a full hour of recorded program, 30 minutes on each side. Virtually any feature-length movie can be sold in this form as a two-disc itself is familiar in form. It is a 12-inch disc composed of vinyl copolymer materials of the type used in an ordinary audio disc. The metallic and dielectric coatings necessary for playback by means of a capacitance pickup give the disc a distinctive shiny appearance and can be inexpensively applied in an automatic continuous process.

## Information on the Disc

The RCA VideoDisc utilizes a spiral groove of roughly circular cross section with a pitch of 5555 grooves per inch. The information is recorded as transverse slots of varying width and separation recorded into the bottom of the otherwise smooth groove and is read out by a stylus which rides in the groove and detects the passage of the relief pattern under it as the disc turns. Figure 1 shows a model of the record surface and the tip

of the stylus riding in the groove. In playback, the disc turns at a constant speed of 450 revolutions per minute. Luminance, chrominance, and audio signals are encoded in the zero crossings of the relief pattern pressed into the disc. As will be described in more detail later, an electron beam is utilized in recording the signal slots. The stylus, which is composed of a main body of sapphire shaped to fit the groove and a thin metal electrode perpendicular to the groove, detects the relief pattern in the record by changes in capacitance between the tip of the electrode and the metallic coating of the record surface as indicated in Figure 2.

In order to conserve bandwidth, the chrominance signal is combined with the luminance signal in a system which we call "Buried Subcarrier Color Encoding." This system depends for its operation on the fact that a television video signal, to a large extent, repeats at horizontal line rate and thus has an energy spectrum with peaks at multiples of line frequency. Such a signal can be passed through a comb filter with peaks at multiples of line frequency with little degradation. The luminance signal is passed through such a comb filter as indicated in Figure 3. This leaves nulls in the energy spectrum, at off multiples of half line frequency, into which the chrominance is encoded. One of the nulls (1.53 MHz) is chosen for the suppressed subcarrier frequency for quadrature modulation by R-Y and B-Y chrominance signals. Since these signals also repeat at line frequency, the resulting side bands occur at multiples of line frequency away from the carrier and thus also fall on the nulls of the luminance comb filter. The modulated chromance signal is passed through a comb filter with transmission peaks at odd multiples of half line frequency, which are interspersed between the peaks of the luminance filter. The comb filtered luminance and chrominance signals are added together to provide a composite video signal with a total bandwidth of 3 MHz which is recorded on the disc as an FM signal, peak white recorded as 6.3 MHz, black as 5.0 MHz, and sync tips as 4.3

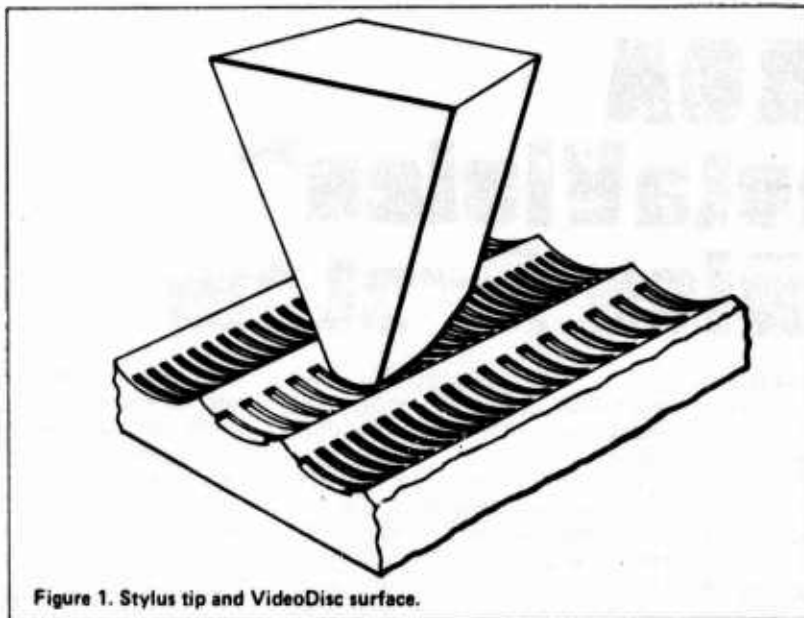

Figure 1. Stylus tip and VideoDisc surface.

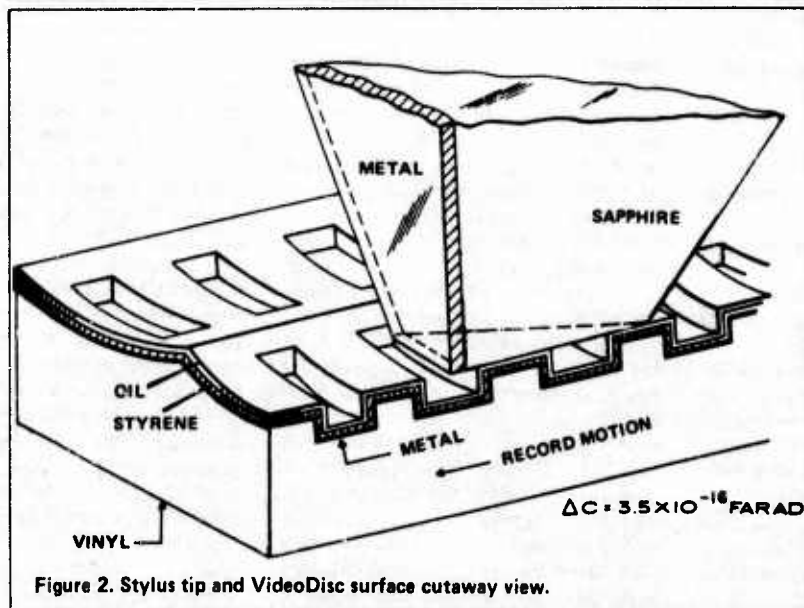

Figure 2. Stylus tip and VideoDisc surface cutaway view.

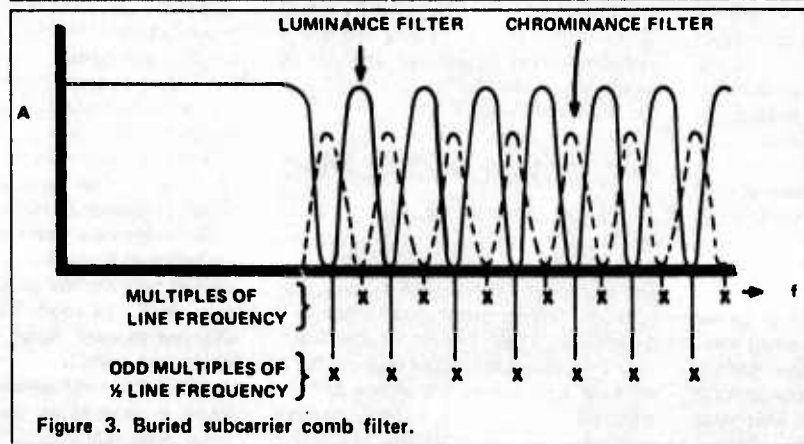

Figure 3. Buried subcarrier comb filter.



MHz as indicated in Figure 4. On playback, after suitable demodulation, the chrominance and luminance are separated by appropriate comb filters and then recombined into a standard NTSC color signal. The audio is included in the recorded signal by duty cycle modulation of the composite video FM signal. Without the audio, the composite video FM signal has a duty cycle of 50%, i.e., the lands are as wide as the slots. The audio is included by deliberately modifying the video FM signal so that the duty cycle is not 50%, i.e., by making the lands periodically wider and narrower than the slots. This is accomplished by frequency modulating suitable carriers with the audio signals, adding the frequency modulated sound carriers to the composite video FM signal and passing the sum signal through a limiter. The result is the duty cycle modulated composite video FM signal which is recorded on the VideoDisc.

With the parameters that have been chosen for the RCA VideoDisc (450 rpm, signals as high as 6.3 MHz, and an inner groove radius of 3.28 inches), the shortest recorded wavelength is about  $0.6 \mu\text{m}$ . When duty cycle modulation is added, the narrowest recorded slots are about  $0.25 \mu\text{m}$ . It has been found convenient to record slots of this width by means of a finely focussed beam of electrons impinging upon electron beam sensitive material (similar in many respects to the more conventional photo-resists).

The disc master upon which recording is done is made by mechanically cutting trapezoidal cross-section grooves in a copper coated aluminum disc, applying electron beam sensitive material in dilute solution to this disc, and letting the sensitive material sag into the grooves as the solvents evaporate as shown in Figure 5. The net result is a disc coated with electron beam sensitive material with the desired spiral groove pattern in its surface.

The coated disc is mounted on a turntable in a vacuum in an electron beam disc recorder so that it can both rotate and translate under a modified scanning electron microscope column as indicated in Figure 6. The electron microscope gun and lenses provide a finely focussed beam of electrons at the surface of the master disc. Both deflected pencil beams and undeflected fan shaped beams have been used for this purpose. In either case, the beam is turned on and off to provide the exposure required. Positive acting sensitive materials are used, which is to say that those portions of the material which are struck by the electron beam can be removed by subsequent development.

Rotation of the turntable is achieved

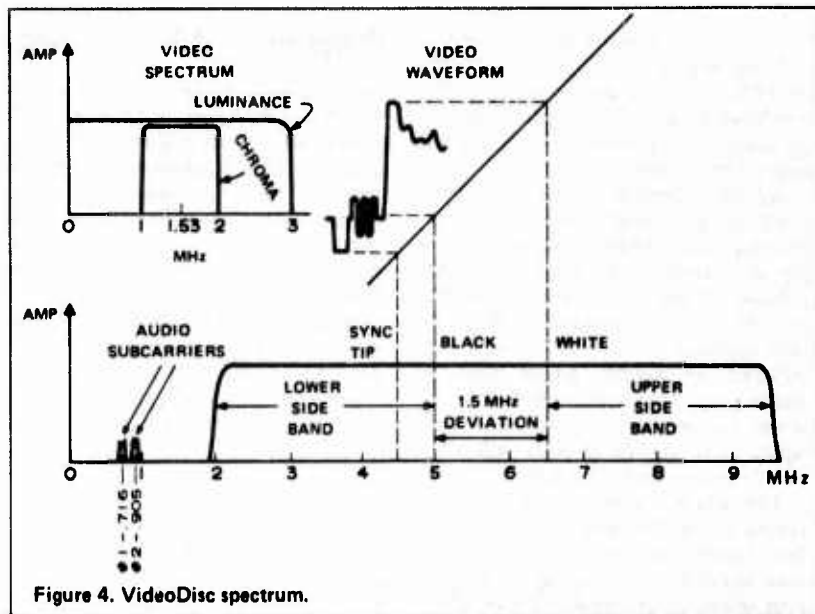

Figure 4. VideoDisc spectrum.

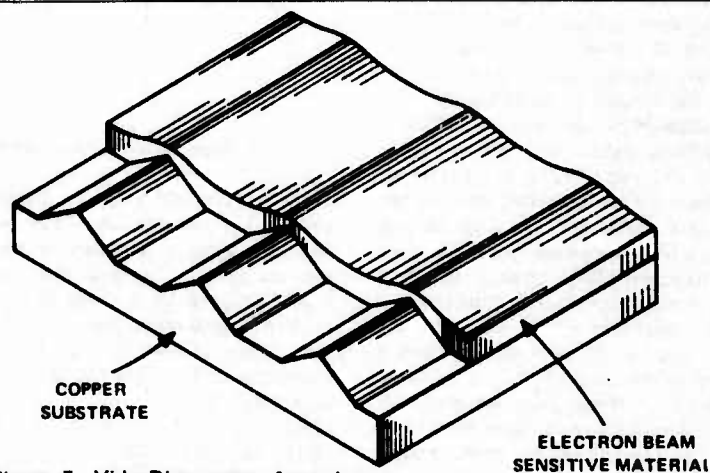

Figure 5. VideoDisc groove formation.

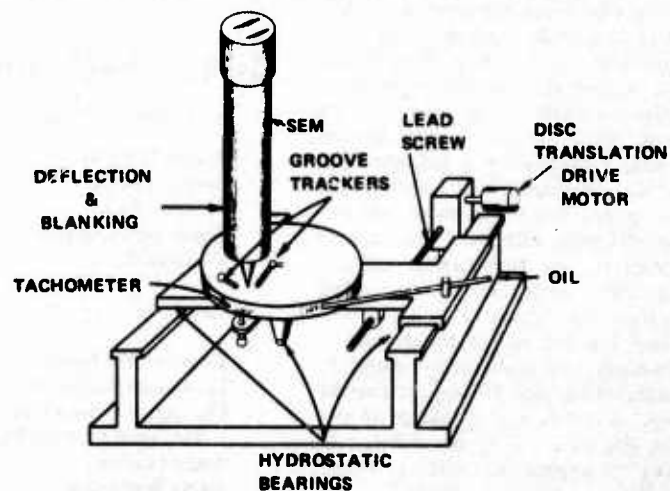

Figure 6. Electron beam disc recorder.

by directing a jet of oil at its periphery and causing it to turn as a turbine. Speed of rotation is measured by an optically interrogated tachometer disc. Speed is controlled by supplying more or less oil to the turbine drive.

As the turntable rotates, it is also translated by a lead screw so that the electron beam remains centered on the pre-cut grooves of the master disc. The position of the groove relative to the electron beam is determined by electrons back scattered from the groove walls and collected by suitable groove tracking sensors. An unbalanced condition in the groove tracking sensors causes corrective signals to be applied to beam deflection circuits and the lead screw drive.

Limitations imposed on the recording system by less-than-desired beam energy and less-than-desired resist sensitivity have dictated that recordings be done at rates which are less than real time. Most RCA records to date have been recorded at 20X below real time, several have been recorded at 5X below real time, and a few have recently been recorded at real time. The increase in recording speed has been achieved mostly by modifications in the electron beam source and its utilization so that more energy is available for exposure. We are currently refining our real time exposure capability in our research laboratories and plan that all of our recording will be done at real time speed at time of product introduction.

After exposure and development, the master disc has the relief pattern which is desired in the final records, as indicated in Figure 1. Metal parts are made for stamping records by the same methods as used for audio records. Electroless plating of the recorded master plus further build-up by electroplating produces a negative metal master. This is replicated by electroplating to provide a positive copy (variously called a mold or a mother). The mold is replicated by electroplating to provide a stamper which is used to press records. While fanout numbers are not yet fully established, it is estimated that one recorded master will produce one metal master, the metal master will produce 10 molds, each mold will produce 10 stampers, and each stamper will produce 1250 records. Thus, each recording operation may result in 125,000 records.

The final step in the manufacture of the records is the application of metal (by vacuum sputtering), styrene (by glow discharge), and oil (by an evaporation process). The metal and styrene enhance the electrical capacitance variations experienced by the stylus-record interface, and the oil provides lubrication to increase both record and stylus life.

## Playback of Recorded Information

As mentioned earlier, playback of the recorded information is by means of a stylus, riding in the groove, which experiences a change in capacitance as the relief pattern of the record passes under the tip of the stylus. The stylus-record capacitance is made part of a resonant circuit (at about 915 MHz), the turning of which is varied by the stylus-record capacitance variations as indicated in Figure 7. When driven by an oscillator of suitable frequency (on the skirt of the resonant curve), the variable frequency resonant

turntable is achieved by driving with a synchronous motor locked to the power line. Small perturbations in playback speed, due to synchronous motor hunting, record off centering, etc., are corrected by an arm stretcher. This unit consists of a small electromechanical transducer (similar to a moving coil loudspeaker element) which drives the stylus arm back and forth along its long dimension, parallel to the record groove. If the record tends to run too slowly, the stylus is pulled toward the transducer to in-

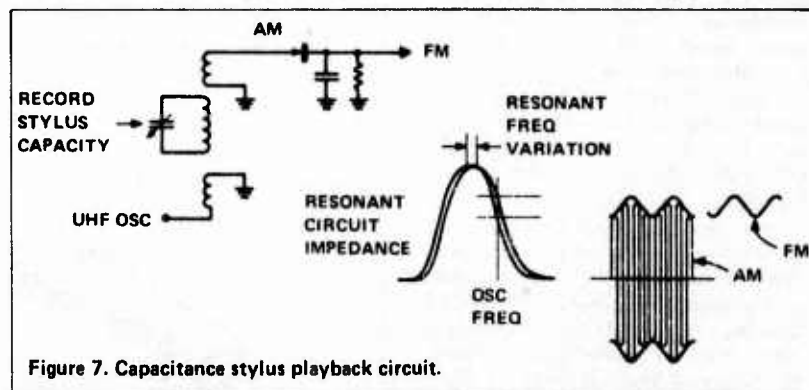

Figure 7. Capacitance stylus playback circuit.

circuit will provide a variable impedance and thus a variable amplitude of the oscillator signal as it passes through the resonant circuit. The amplitude modulation is stripped by a diode detector to provide a signal which rises and falls with the passage of the slots in the record under the stylus. This FM signal is demodulated to provide the composite video signal mentioned earlier. The audio signals are recovered by appropriate filtering followed by FM detectors.

Average speed control of the playback

increase the relative speed between stylus and record, and if the record runs too fast, the stylus is pushed away from the transducer to reduce the relative speed. Error signals to control the arm stretcher are derived from measurements of the color burst frequency as the record is played.

Defect compensation is provided by a 1 H delay line, appropriate sensing circuitry, and video switches to substitute the video from a previous line whenever defects occur on the present line.

## System Parameters

A summary of the pertinent parameters of the RCA VideoDisc system follows:

Record Diameter	12 inches
Record Thickness	0.07 inches (at center and outside rim)
Rotation Rate	450 rpm
Center Hole Diameter	1.5 inches
Recorded Band	2.44 inches wide (5.72 to 3.28 inches radius)
Play Time	30 minutes each side 60 minutes total (two sides)
Recorded FM Signal	4.3-6.3 MHz
Luminance Bandwidth	3.0 MHz
Chrominance Bandwidth	0.5 MHz
Video Signal to Noise Ratio	>40 dB
Audio Carriers	716 and 905 kHz
Audio Bandwidth	15 kHz
Audio Signal Frequency Deviation	± 50 kHz
Audio Signal to Noise Ratio	60 dB approximately

ENCLOSURE 6

Digital Recording. An Optical System for High Density  
Information Storage and Retrieval.  
Corporate Paper

## INTRODUCTION-SUMMARY

The Digital Recording system is a commercially feasible system for ultradense information storage and retrieval. A demonstration unit has been constructed to illustrate the performance and engineering practicality of the system. The demonstration unit has been used to record live color TV signals for later playback. Storage densities of 300 million bits per square inch have been achieved easily, a density that allows 30 minutes of TV programming to be recorded on a 5" x 7" record. The demonstration unit shows that no new technology is needed for commercial development; only relatively inexpensive components are required.

The system appears to have broad application. For example, typewritten text can be stored in digital code in a space several thousand times smaller than the space required by microfilm. Complete computer compatibility is easily provided because the information is handled in digital form. The system can record or read out information faster than any present-day computer can handle and, if it is desirable, the information can be encrypted for security.

Record materials are inexpensive and, with the appropriate equipment, an entire record can be transferred instantly for replication by the supplier. However unauthorized copies are very difficult to make.

The system is thus well suited for archival storage and retrieval, computer-associated software or firmware applications, high-speed, on-line data logging or process control applications, professional TV, professional audio mastering, or other information handling problems where high signal-to-noise ratio, a high bit rate or a high bit density is desirable.

For many special applications the technology of Digital Recording can be used essentially as it stands and unit costs should be quite competitive.

For consumer TV playback units where millions of units would be produced, production engineering can be expected to bring manufacturing cost down to the range of \$120 per unit. This attractive figure, coupled with the prospect of capturing the entire market for record supply, suggests that a truly remarkable commercial opportunity based on Digital Recording may now be developing. Some of the applications of the system are described on the immediately following pages. Digital Recording promises to be highly cost competitive in the areas listed and, in many instances, it offers entirely unique capabilities.

The system is quite simple. For recording information, the material to be stored is converted to digital code and written as a series of micron-size dots and spaces on a fixed photosensitive plate. The plate is then either photoprocessed or not, depending on the photosensitive medium being used, and placed on the playback unit, which may be the same unit used for recording. In the playback process the digital tracks are scanned by a light beam in the same fashion as in recording, except that tracking adjustment is provided to compensate for any small misplacement of the record or other mechanical variation. The playback beam will thus be modulated according to the digital code on the record and, after conversion to an electrical signal by a photodetector, the original information is recovered from the digital code by conventional digital-to-analog conversion procedures. Fidelity is virtually perfect and there is no record wear in the process.

The Digital Recording Corporation has exclusive license to all patents and technology developed in connection with the Digital Recording process. Inquiries concerning licensing, application of the process or related matters should be directed to the Digital Recording Corporation.

## PRINCIPLES OF OPERATION

### Optical/Mechanical Principles

A broad range of design configurations is encompassed by Digital Recording system patents. For the sake of clarity one typical design configuration will be described here to illustrate principles of operation. The recording process is described first.

The Digital Record itself, that is, the information recorded, is a sequence of discrete microspots and microspaces distributed along curved paths on a photosensitive medium. A 4" x 5" record used in the demonstration system is shown in Figure 3. In the particular design we are describing now, the data are scanned in serial order onto a photoplate by a spin-nir scanning head that has several equally spaced scanning apertures around its periphery (Figure 4).

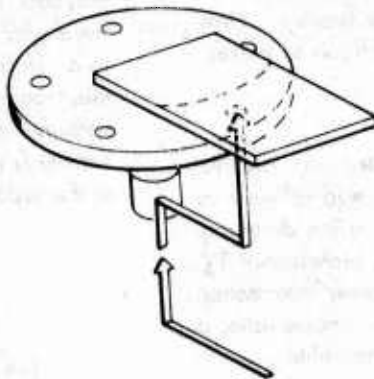

FIGURE 4. Scanning Arrangement

An optical distributor fixed to the spindle of the scanning head switches the recording beam from one aperture in the scanning head to the next in such a way that the data at the end of one track are picked up at the start of the next track by the next aperture of the scanner (Figure 5).

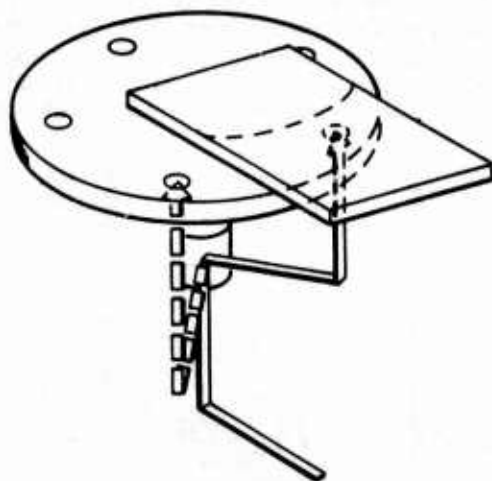

FIGURE 5. Optical Distributing System

To write sequential tracks on the record it is necessary to translate either the record or the scanner. It is better for reasons that will be discussed later to have the record fixed and have the scanning head translate with respect to the record as shown (Figure 6).

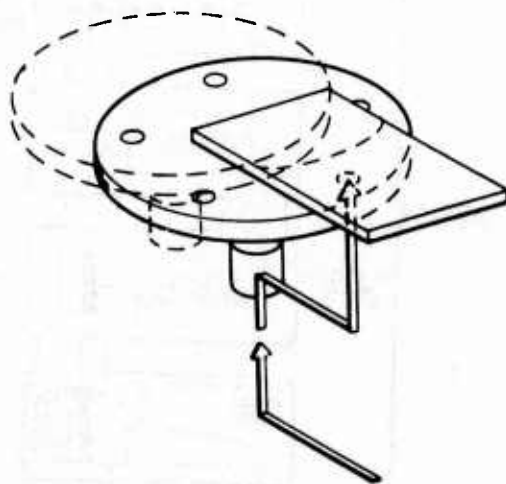

FIGURE 6. Scanning Head Translation

When the recording is completed the record is photoprocessed and replaced on the same or similar scanning machine. The playback process is then essentially the same as the recording process. The spinning scanner is translated with respect to the record exactly as before but now the light source is on, illuminating the data track continuously. As the record is scanned the light strikes either bright spots or dark spots on the record and is, in turn, reflected back through the optical system, pulsing precisely according to the serial distribution of light and dark spots. For negative processing a dark spot is a "1 bit" and a clear spot is "0 bit". Reverse processing can also be done. A beam splitter in the playback beam path directs a fraction of the now modulated return beam to a photoelectric detector that produces an electric signal carrying the digital information of the record (Figure 7).

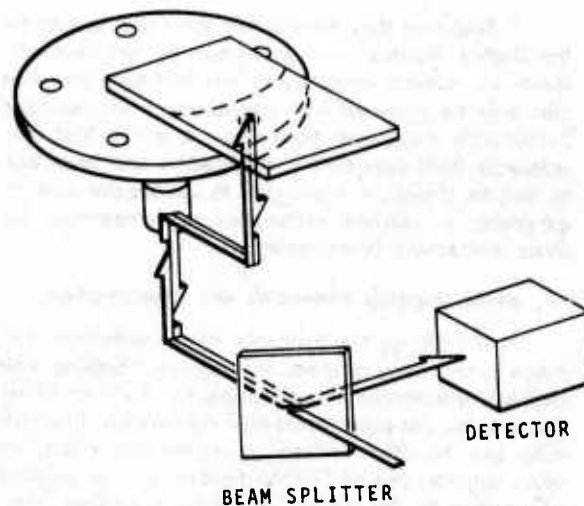

FIGURE 7. Read Back Light Path

In practice, it is necessary to arrange for a tracking adjustment to keep the scanning beam exactly on the data track. This is required because the same machine would not, in general, be used for both recording and playback; therefore, compensation for slight differences between machines must be made. Furthermore, even if the same machine is being used for recording and playback, the record being played may be in a slightly different position than it was recorded, or the several apertures of the scanning head may not be following the same tracks they

followed during recording. A tracking servo is used to deflect the beam slightly as required for tracking during playback (Figure 8).



FIGURE 8. Correction of Tracking Deviation

Realizing that the discrete spots and spaces on the Digital Record are separated by only microns, there is a natural tendency to feel that such precision can only be attained with exceptionally precise (and presumably expensive) hardware. It is true that considerable final precision is required in one area but, as will be shown, it is possible to use special and inexpensive production techniques to compensate for those mechanical inaccuracies.

#### Analog-to-Digital Conversion and Reconstruction

In describing the principles of the system so far, it has been simply assumed that we were dealing with digitized information from the outset. This would be the case for computer-associated applications in which data are handled entirely in digital form. But, for many applications of Digital Recording, the original information to be stored would be in analog form. For example, television signals, music, photographic or microfilm data would all be in analog form which first must be converted to digital form for recording.

The methods for such analog-to-digital (a/d) conversion and for the reverse process (d/a) are part of well established electronics technology. It would be out of place to discuss the standard methods in detail here. The following paragraphs provide just a brief, qualitative sketch of the conversion process as used in this system so that those unfamiliar with the techniques may follow subsequent portions of this report more easily.

The general process is illustrated in Figure 9. Beginning with a time varying analog signal as shown

schematically at the top of the figure. One may imagine the original signal to be voltage variations corresponding to music picked up by a microphone or one can think of it as an incoming television signal. The signal is sampled very rapidly; effectively it must be sampled at a frequency at least twice as high as the highest frequency component to be retained from the signal. Each sample may be considered an instantaneous measurement of voltage. The sample voltage has some numerical value which we might write in decimal form (0.53 volts, for example). All such decimal numbers can also be expressed in binary code or other digital code and typically the a/d conversion process

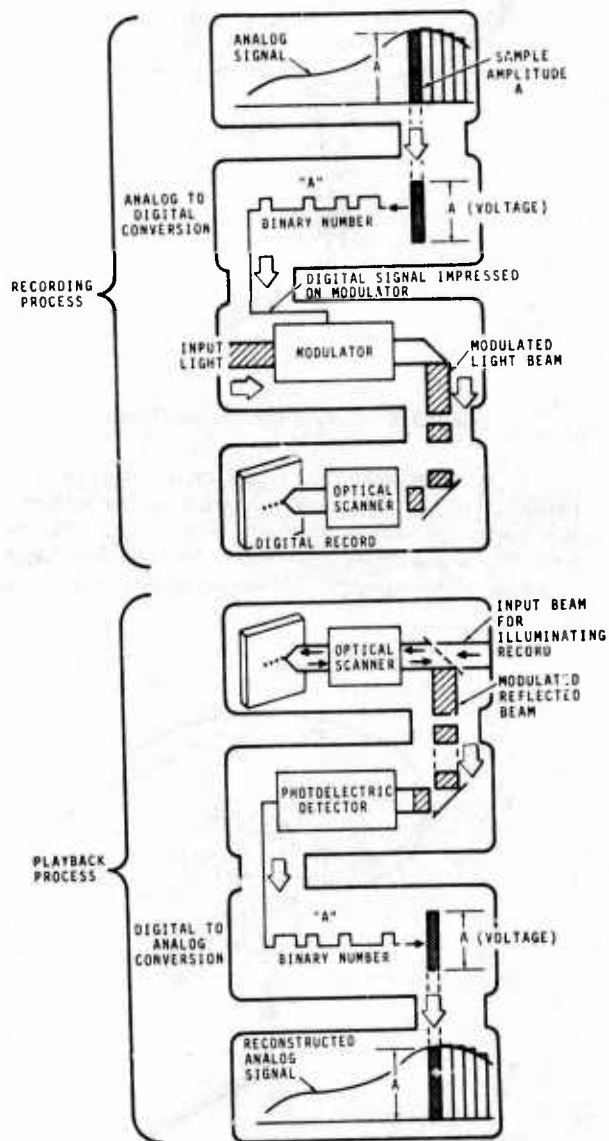

FIGURE 9.

consists of producing a continuous string of digitally coded numbers corresponding to a continuous sequence of samples.

With a binary code, a number may be written with just two symbols, e.g., on-off, yes-no, black-white, etc. Thus by coupling electrical pulses corresponding to a digitally coded number to a light beam modulator we can impress pulses on a light beam and use the modulated beam to produce a set of dots and spaces on the photosensitive record. The dots and spaces are in effect simply numbers recorded one after another in a digital code. They correspond to a sequence of samples of the analog signal.

As shown in the bottom half of the accompanying diagram, the playback process is just the reverse of the recording process. Light pulses are converted to a digital electrical signal from which the analog signal is reconstructed electrically.

From this brief description, one can see that one of the basic concerns in any a/d and d/a process is whether the final, reconstructed analog signal is a sufficiently faithful reproduction of the original one. There are two main factors involved. First, the sample slices must be sufficiently thin; that is, the sampling frequency must be high enough. Second, it is important to be able to express the numerical value of the sample precisely. Just as we need many significant figures to write a decimal value precisely, many bits are required to write a digital number precisely. If only coarse values can be written for the sample values, there will be too much jump from one vertical bar in the reconstructed signal to the next. The result is "digital noise", a static-like effect. To write precise sample values requires adequate digital word length.

The design engineer thus has to decide what sampling frequency to use and how many bits per word to allow. The product of sampling frequency times word length is the "bit rate", the number of bits per second. Fortunately, the theory and the art of these considerations are very well developed. Electronic digitization and reconstruction can thus be accomplished with an accuracy that often exceeds present capability for transforming the raw information to an analog signal in the beginning, and distortion is nonexistent after digitizing.

There is one last thing to add to this brief discussion of a/d and d/a conversion. The process described above is a reasonable one, and one we have used on occasion. But for many kinds of analog signals there is a more efficient procedure; really just

a variation of what we have described. Rather than digitize the actual values of the analog samples, it is often better to measure and digitize just the change from one sample to the next. The changes are typically smaller than the sample values themselves; consequently shorter digital numbers can be written. This technique of dealing with differences rather than absolute values goes by the general name "differential modulation". It allows even more information to be put on a record.

## 5. DESIGN CONSIDERATIONS

Existing demonstration hardware operates very much as described in the preceding paragraphs. The demonstration apparatus was designed to illustrate not only performance capability but also the engineering practicality of the system. The recording and playback of live color TV offered a very stringent test of performance capability.

With this practical demonstration now accomplished, all of the markets listed at the beginning of this report are clearly within reach. Several of the market applications listed could be met by production versions of hardware that would be much like the demonstration apparatus itself.

Figure 10 illustrates the principal components of the demonstration unit. The unit itself is shown in the photograph.

Figure 11 illustrates how the unit might be repackaged for a production version of the system. The main design elements would be the same but designed for low cost production.

Cost factors will be discussed in more detail later but here certain key cost considerations might be noted that apply to both the demonstration apparatus and the production version shown.

### Cost Advantages Important to Production Design

- Only simple on-axis optics are used
- Conventional spindle bearings available from commercial sources are used
- There is wide tolerance for wear
- Electronics are integrated logic
- Mechanical error compensation by electronic or optical means.



These are very important practical considerations for a low-cost production design.

All of the discussion so far has centered on a system using a single-track, mechanically scanned record. However, that design is only one of many design configurations covered by Digital Recording patents. Figure 12 illustrates diagrammatically the range of design choices available beginning with scanner arrangements at the top of the figure. The system

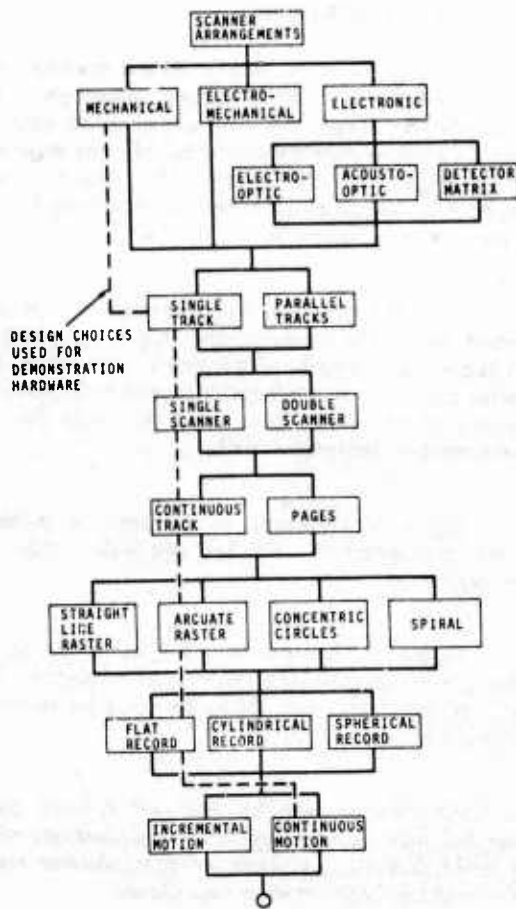

FIGURE 12. System Design Choices

that has already been discussed is marked on the diagram with a dotted line. Similar sets of choices are available for record format and for record material as shown in Figures 13 and 14. For future development of Digital Recording and special applications of the system, the broad range of choices available to the designer provides considerable system flexibility.

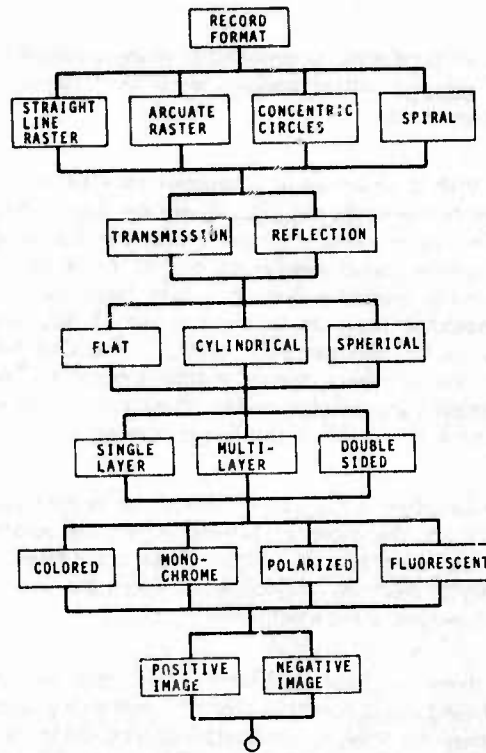

FIGURE 13. Record Format Design Choices

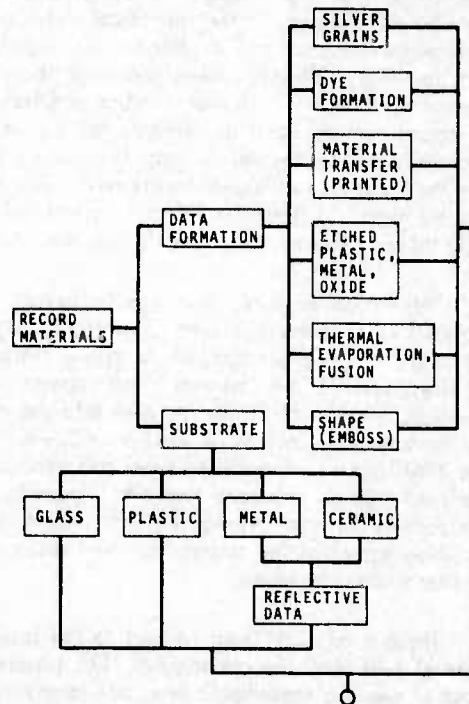

FIGURE 14. Record Material Design Choices

An important overall design consideration is that of avoiding the shortcomings of "competitive" systems and of gaining relative performance and cost advantages. Without going into descriptions of other advanced recording systems (Philips, MCA, Zenith, Thomson CSF), a list is given in Figure 15 of the competitive advantages provided by Digital Recording.

In summarizing design considerations it should be noted that a remarkably broad range of design choices are available under the Digital Recording patents. The possible design variants span the most attractive approaches in a major new field of information storage and retrieval hardware. The design flexibility available is adequate to sustain continued technological innovation in this field for many years.

## ILLUSTRATIONS

1. Photo of Hand-Held Disc (Courtesy I/O Metrics Corp.)
2. Comparative Packing Densities (Courtesy Zenith Radio Corp.)
3. A Brief Description - Disc Systems - Types
4. Comparative Cost Studies
5. Metric Unit Prefixes
6. 5th Generation Copy From 525 Line Screen of Chicago Telephone Directory (Courtesy Zenith Radio Corp.)



**FIGURE 1 — PHOTO OF HAND-HELD DISC**

This figure shows the appearance of an I/O Metrics video film disc. The disc is 30 cm (12 inches) in diameter and is identical in its physical characteristics to ordinary black and white photographic negatives. The disc consists of a tough, pliable substrate with a high resolution emulsion which is capable of carrying in excess of one hour of video programming with quadrasonic sound track. The disc may be handled casually without the need for excessive care; it may be stored and shipped in a rolled or flat shape.

**INFORMATION DENSITY**

VIDEO DISC

PHOTO FILM

VIDEO TAPE

AUDIO DISC

AUDIO TAPE

**AREA REQUIRED  
FOR 1,000,000 BITS**



Figure 2. Comparative Packing Densities (Courtesy Zenith Radio Corp.)

A BRIEF DESCRIPTION - DISC SYSTEMS - TYPES

COMPANY NAME	REFLECTION		PHASE TRANSMISSION		AMPLITUDE		FM (Frequency Modulation)		DIRECT (ANALOG)		DISC SPEED (RPM)		PLAYBACK SYSTEM		DISC		DISC MAT'L		REC TIME (MIN) ONE SIDE		REPLICATION		IMMEDIATE PLAYBACK	
	X		X		X		X		X		1500	1800	LASER	30cm	PVC	30	PRESSING AND REFLECT. COATING	NO	NO	NO	NO	NO	NO	
PHILIPS	X		X		X					1500	1800	LASER	30cm	PVC	30	PRESSING AND REFLECT. COATING	NO	NO	NO	NO	NO	NO	NO	
MCA	X		X		X					1800		LASER	12in.	MYLAR	20	REFLECT. COATING	NO	NO	NO	NO	NO	NO	NO	
ZENITH		X	X		X					1500	1800			PVC		PRESSING	NO	NO	NO	NO	NO	NO	NO	
THOMSON - France		X	X		X					1800		LASER DIFFRACTION	12in.	PVC	25	TECHNIQUE	NO	NO	NO	NO	NO	NO	NO	NO
I/O METRICS		X	X		X			X		1500	1800	LAMP PHOTO-MULTIPLIER TUBE	12in.	POLYESTER FILM	30	PHOTO-GRAPHIC	NO	NO	NO	NO	NO	NO	NO	NO
DRC - BATTELLE		X	X		X					3600		SPINNING SCANNER LASER		5 x 7 PHOTO FILM 4 x 5 CARD	30	PHOTO-GRAPHIC	NO	NO	NO	NO	NO	NO	NO	NO
TELEFUNKEN - TED Berlin, W. Germany					X					1500	1800	MECH. PRESSURE	21cm	PVC	10	PRESSING TECHNIQUES	NO	NO	NO	NO	NO	NO	NO	NO
RCA					X					450		MECH. CAPACITIVE	12in.	PVC	30	PRESSING TECHNIQUES	NO	NO	NO	NO	NO	NO	NO	NO

Figure 3.

COMPARATIVE COST STUDIES

COMPARATIVE COSTS OF SILENT STILL VISUAL INFORMATION RECORDED AND DISTRIBUTED ON CONVENTIONAL FORMATS AND ON VIDEOCISC. IT IS ASSUMED THAT THE PRODUCTION RUN IS FOR 5,000 COPIES OF 60,000 FRAMES EACH.

For the cost of 1 frame on:	a slide	a filmstrip	B&W microfilm	color microfiche
The videodisc will provide:	11,541 frames	981 frames	879 frames/pages in color	1,044 frames/pages in color

COMPARATIVE COSTS OF MATERIALS ORIGINATED ON MOTION-PICTURE FILM OR TELEVISION VS VIDEOCISC DISTRIBUTION.  
 PRODUCTION RUN IS 6,000 COPIES.

For the cost of one 1/2-h film or program copy on:	35mm	16mm	super-8	2-in videotape	1-in videotape	3/4-in video-cassette
The videodisc will provide --- no. of 1/2-h programs:	268	139	84	330	170	43

Journal of the SMPTE

July 1974, Vol. 83, No. 7

Figure 4.

## Metric Unit Prefixes

VALUE	MULTIPLES & SUBMULTIPLES	PREFIXES	SYMBOLS
1 000 000 000 000 <sup>**</sup>	$10^{12}$	tera	T
1 000 000 000	$10^9$	giga	G
1 000 000	$10^6$	mega	M <sup>#</sup>
1 000	$10^3$	kilo	k <sup>#</sup>
100	$10^2$	hecto	h
10	10	deka	da
0.1 <sup>***</sup>	$10^{-1}$	deci	d
0.01	$10^{-2}$	centi	c <sup>#</sup>
0.001	$10^{-3}$	milli	m <sup>#</sup>
0.000 001	$10^{-6}$	micro	u <sup>#</sup>
0.000 000 001	$10^{-9}$	nano	n
0.000 000 000 001	$10^{-12}$	pico	p

<sup>#</sup> Most commonly used.

<sup>\*\*</sup> In accordance with SI Standards, a comma is never used to show thousands. Instead, group digits in threes and leave a space between.

<sup>\*\*\*</sup> In accordance with SI Standards in the "metric system", a zero "0" is placed to the left of the decimal point in metric dimensions of less than one millimetre.

Figure 5.



7206 Calumet Hamnd-----

Elect Serv Inc

838 169th Hamnd-----WE

400 E 5 Av Gary-----885

**W ROOT BEER-WHITEY'S**

5223 E Dunes Hwy Gary-938

Realty 513 Conkey Hamnd-----932

Heating & Air Conditioning Company Inc

4711 Euclid EChgo-397

Heating Company Inc

220 Detroit Hamnd-----982

241 W 11th Av Gary-----885

berg A C 6020 Wallace Hamnd:-WA

Figure 6. 5th Generation Copy From 525 Line Screen of Chicago Telephone Directory (Courtesy Zenith Radio Corp.)

INITIAL DISTRIBUTION

Copies

1 OASD (I&L)/Mr. R. Shorey  
 2 DLSIE  
 1 ODDR&E/COL. Henry L. Taylor  
 1 AMC(MA-SM4)/ Mr. R. Graves  
 2 ARI  
     Dr. Otto Kahn  
     Dr. Joseph Ward  
 1 ARMY HEL(AMXHE HEL)  
     Mr. D. S. Mackey  
 2 AMXMD-EP  
     Mr. Roy Post  
     Mr. Art Rulon  
 1 AMSEL-HL-CT-0  
 1 CG, USA ELEC LAB  
 1 TRADOC/COL. F.A. Hart  
 6 CNO  
     (OP-09B1)  
     (OP-355)  
     (OP-401G)/Mr. B. Gruber  
     (OP-987)/Dr. R. Smith  
     (OP-991B)/Mr. M. Malehorn  
     (OP-991C)/Mr. D. Thurman  
     (OP-007)  
 1 CINCLANTFLT/Code NFU3  
 1 CINCPACFLT/Code 431  
 1 COMSUBLANT/Code N4013  
 1 COMSUBPAC/Code 40  
 1 COMSUBLANT/Code 40

Copies

4 COMNAVSURFLANT  
     Code N42  
     Code N44  
     Code 64  
     READSUPGRU  
 1 COMNAVSURFPAC/Code 40  
 1 COMNAVAIRLANT/Code 512  
 1 COMNAVAIRPAC/CDR Rein  
 1 COMOPTEVFOR/Code 36  
 1 Fleet Intelligence Center, Pacific  
 3 CNET  
     (N50)/Dr. W. Scanland  
     (N521)/Mr. Bob Jones  
     (N54)/Mr. John H. Pinning  
 1 CNETS (3314)/Mr. J. Barron  
 3 CNTT  
     (0101)/Dr. N. Kerr  
     (0162)/Mr. E. M. Evans  
     (N331)/Mr. A. P. Zaluski  
 3 NTEC  
     (N210)/Dr. J. Duva  
     (N215)/Dr. William King  
     (N423)/Mr. Ralph Laugen  
 3 NAVMAT  
     (0344)/Mr. I. Rubinstein  
     (04)/ Mr. J. Genovese  
     (0422)/Mr. W. O'Hern  
 2 BUPERS  
     (PERS 212D)/LCDR L.W. Beguin  
 1 CNR (45B)/Dr. M. Farr  
 1 NSWC/White Oak/(Code 740)  
 1 NAVELEXENGCEN SDIEGO/Mr. G. Myles

INITIAL DISTRIBUTION (continued)

Copies

2 NAVSUP  
(0431C)/Mr. G. Bernstein  
(10)/Mr. H. Burby

8 NAVSEA  
(00G)/Mr. H. Hill  
(0463)/Mr. W. G. Shihda  
(660F)/Mr. D. Baird  
(660F)/Mr. J. Jenkins  
(6181C)/Mr. S. Myers  
(PMS 301)/CAPT Parker  
(PMS 403-15)/Mr. T. W. Taylor  
(PMS 306)

1 NAVSEACEN SDIEGO

14 NAVAIR  
(04A4)/Mr. H. Keneman  
(04A4)/Mr. W. G. Muller  
5 (340C)/Mr. D.S. Hurst  
2 (340F)/LCDR P. Chatelier  
5 (539A)/Mr. C.F. Armstrong

5 NPRDC  
Dr. J. Regan  
Dr. E. Akin  
Dr. G. Ramas  
Dr. T. Curran  
Dr. R. Blanchard

3 TAEG(NOOT)/Dr. R. Braby

1 NAVTRADEVCCEN, Orlando, Fla.

1 OPTEVFOR(36)/CDR. I. Donovan

2 NSWSES (5001)/Mr. C. Root

1 NSDSA (5700)/Mr. K. Radcliff

3 NTC, San Diego  
CAPT C. McDaniel  
Mr. D. Lovell  
(PQSDG)/CDR Peterson

1 NTC, Great Lakes  
CAPT O'Malia

Copies

25 NPC/Mr. G. Bull

1 NAVRECONNTECHSUPCEN, Wash., D.C.

1 Navy Occupation Development and  
Analysis Center (CODAC)  
CAPT E. M. Anderson, C.O.

12 Defense Documentation Center

1 USAF (LGYE)/Mr. R. Welsh

1 USAF (DAYX HDQ)/Dr. Ron Burkett

1 USAF (DAYX HDQ)/Mr. V. Kehler

2 AFHRL (WPAFB)  
Mr. J. Klesch  
Mr. R. Johnson

3 HQ, AFLC (WPAFB)  
(ASD/SMA) COL. J. Ostrominski  
(LOLMP)/Mr. M. DeLisio  
(PRAM)/Mr. W. Wiser

1 ASD/ENR, WPAFB, OH

1 ADS/RWR, WPAFB, OH

1 AF Avionics Lab./RS WPAFB, OH

1 AFAL (AVRP), WPAFB, OH

1 AFCS HE, FTD (TDAOS) WPAFB, OH

1 USAF HQ (AFRDRM), Wash., D.C.

1 USAF HQ/INYD, Wash., D.C.

1 AFSC/SDRS, Andrews AFB, MD

1 RADC/IRR, Griffiss AFB, NY

1 NAVINSTSERVLIAO/PHOTO, Hill AFB, Utah

1 Naval Intelligence Center  
(NiC-323), Alex., VA

INITIAL DISTRIBUTION (continued)

Copies

1 NSA/R55 (Mr. J.C. Davis)  
1 ASO, Code SCG-3-C, Phila., PA.  
1 MCLFDC, GCD, Quantico, VA.  
1 CMC, (AO3P), Wash., D.C.  
1 University of Ohio/Dr. G. Klare  
1 University of MD/Dr. T. Powers  
5 Hughes Aircraft Company  
ATTN: Mr. J. Connell, M-308  
Ground Systems Group  
P. O. Box 3310  
Fullerton, CA.

Copies

1 BioTechnology, Inc.  
ATTN: Mr. T. Post  
3027 Rosemary Lane  
Mr. T. Post  
1 ManTech of New Jersey  
ATTN: Mr. R. Royston  
6110 Executive Blvd.  
Rockville, MD.  
1 Stanford Research Institute  
ATTN: Mr. J. Bialik  
333 Ravenswood Avenue  
Menlo Park, CA.  
1 Telecom Systems, Inc.  
ATTN: Mr. Skewis  
2300 South 9th Street  
Arlington, VA.  
1 Westinghouse Corp.  
ATTN: Mr. J. Box  
3709 Pepper Road  
Hunt Valley, MD.

CENTER DISTRIBUTION (continued)

Copies	Code	Copies	Code
1	18	1	1808
1	1809.1	1	184
1	1809.3	1	186
1	183	2	1861
1	185	1	1864
30	186A	1	1867
1	1863	1	188
1	1865	1	2784
1	1868		