

UNCLASSIFIED

AD NUMBER

ADB014036

LIMITATION CHANGES

TO:

Approved for public release; distribution is unlimited.

FROM:

Distribution authorized to U.S. Gov't. agencies only; Test and Evaluation; JUN 1976. Other requests shall be referred to Rome Air Development Center, Attn: IRRO, Griffiss AFB, NY 13441.

AUTHORITY

RADC ltr, 26 Sep 1980

THIS PAGE IS UNCLASSIFIED

THIS REPORT HAS BEEN DELIMITED
AND CLEARED FOR PUBLIC RELEASE
UNDER DOD DIRECTIVE 5200.20 AND
NO RESTRICTIONS ARE IMPOSED UPON
ITS USE AND DISCLOSURE.

DISTRIBUTION STATEMENT A

APPROVED FOR PUBLIC RELEASE;
DISTRIBUTION UNLIMITED.

✓

② 4

RADC-TR-76-87
Final Technical Report
June 1976



A DESIGN STUDY FOR QUICK STRIKE RECONNAISSANCE/
RECONNAISSANCE REPORTING FACILITY

Texas Instruments Incorporated

AD B 014036

AD No. _____
DDC FILE COPY

Distribution limited to U. S. Gov't agencies only;
test and evaluation; June 1976. Other requests
for this document must be referred to RADC (IRRO),
Griffiss AFB NY 13441.

DDC
RECEIVED
OCT 15 1976
RECEIVED

JA A

ROME AIR DEVELOPMENT CENTER
AIR FORCE SYSTEMS COMMAND
GRIFFISS AIR FORCE BASE, NEW YORK 13441

A DESIGN STUDY FOR QUICK STRIKE RECONNAISSANCE / RECONNAISSANCE REPORTING FACILITY

This report has been reviewed and is approved for publication.

APPROVED: *Ronald B. Haynes*
RONALD B. HAYNES
Project Engineer

APPROVED: *H. Davis*
HOWARD DAVIS
Technical Director
Intelligence and Reconnaissance Division

FOR THE COMMANDER: *John P. Huss*
JOHN P. HUSS
Acting Chief, Plans Office

Do not return this copy. Retain or destroy.

MISSION
of
Rome Air Development Center

RADC plans and conducts research, exploratory and advanced development programs in command, control, and communications (C³) activities, and in the C³ areas of information sciences and intelligence. The principal technical mission areas are communications, electromagnetic guidance and control, surveillance of ground and aerospace objects, intelligence data collection and handling, information system technology, ionospheric propagation, solid state sciences, microwave physics and electronic reliability, maintainability and compatibility.



UNCLASSIFIED

SECURITY CLASSIFICATION OF THIS PAGE (When Data Entered)

REPORT DOCUMENTATION PAGE		READ INSTRUCTIONS BEFORE COMPLETING FORM	
1. REPORT NUMBER RADC TR-76-87	2. GOVT ACCESSION NO.	3. RECIPIENT'S CATALOG NUMBER	
4. TITLE (and Subtitle) A DESIGN STUDY FOR QUICK STRIKE RECONNAISSANCE/ RECONNAISSANCE REPORTING FACILITY.		5. TYPE OF REPORT & PERIOD COVERED Final Technical Report. Jul 75 - Dec 75	
7. AUTHOR(s) Steve Godfrey		6. PERFORMING ORG. REPORT NUMBER TI-75-C-0207	
9. PERFORMING ORGANIZATION NAME AND ADDRESS Texas Instruments Incorporated/Navigation, Attack Radar & Digital Systems Div/Equipment Group P O Box 6015, Dallas TX 75222		8. CONTRACT OR GRANT NUMBER(s) F30602-75-C-0270	
11. CONTROLLING OFFICE NAME AND ADDRESS Rome Air Development Center (IRRO) Griffiss AFB NY 13441		10. PROGRAM ELEMENT, PROJECT, TASK AREA & WORK UNIT NUMBERS 64710F 20570201	
14. MONITORING AGENCY NAME & ADDRESS (if different from Controlling Office) Same		12. REPORT DATE June 1976	
16. DISTRIBUTION STATEMENT (of this Report) Distribution limited to U. S. Gov't agencies only; test and evaluation; June 1976. Other requests for this document must be referred to RADC (IRRO), Griffiss AFB NY 13441.		13. NUMBER OF PAGES 126	
17. DISTRIBUTION STATEMENT (of the abstract entered in Block 20, if different from Report) Same		15. SECURITY CLASS. (of this report) UNCLASSIFIED	
18. SUPPLEMENTARY NOTES RADC Project Engineer: Ronald B. Haynes (IRRO) Copies available in DDC.		15a. DECLASSIFICATION/DOWNGRADING SCHEDULE N/A	
19. KEY WORDS (Continue on reverse side if necessary and identify by block number) Remote Sensing, Image Processing, Image Interpretation, Intelligence, Data Processing, Image Displays			
20. ABSTRACT (Continue on reverse side if necessary and identify by block number) This report contains the results of a functional design study of the Quick Strike Reconnaissance (QSR) Reconnaissance Reporting Facility (RRF). The RRF is based on maximizing the use of currently available commercial or militarized components interfaced with the data processing equipment and software of the Imagery Interpretation (II) segment of the Tactical Information Processing and Interpretation (TIPI) system. The study presents specific equipment configura- tions and alternatives for both a FLIR-only RRF and an exploitation facility capable of processing both data linked FLIR and AAD-5 sensor imagery.			

DD FORM 1 JAN 73 1473 EDITION OF 1 NOV 68 IS OBSOLETE

UNCLASSIFIED
SECURITY CLASSIFICATION OF THIS PAGE (When Data Entered)

405076

UNCLASSIFIED

SECURITY CLASSIFICATION OF THIS PAGE(When Data Entered)

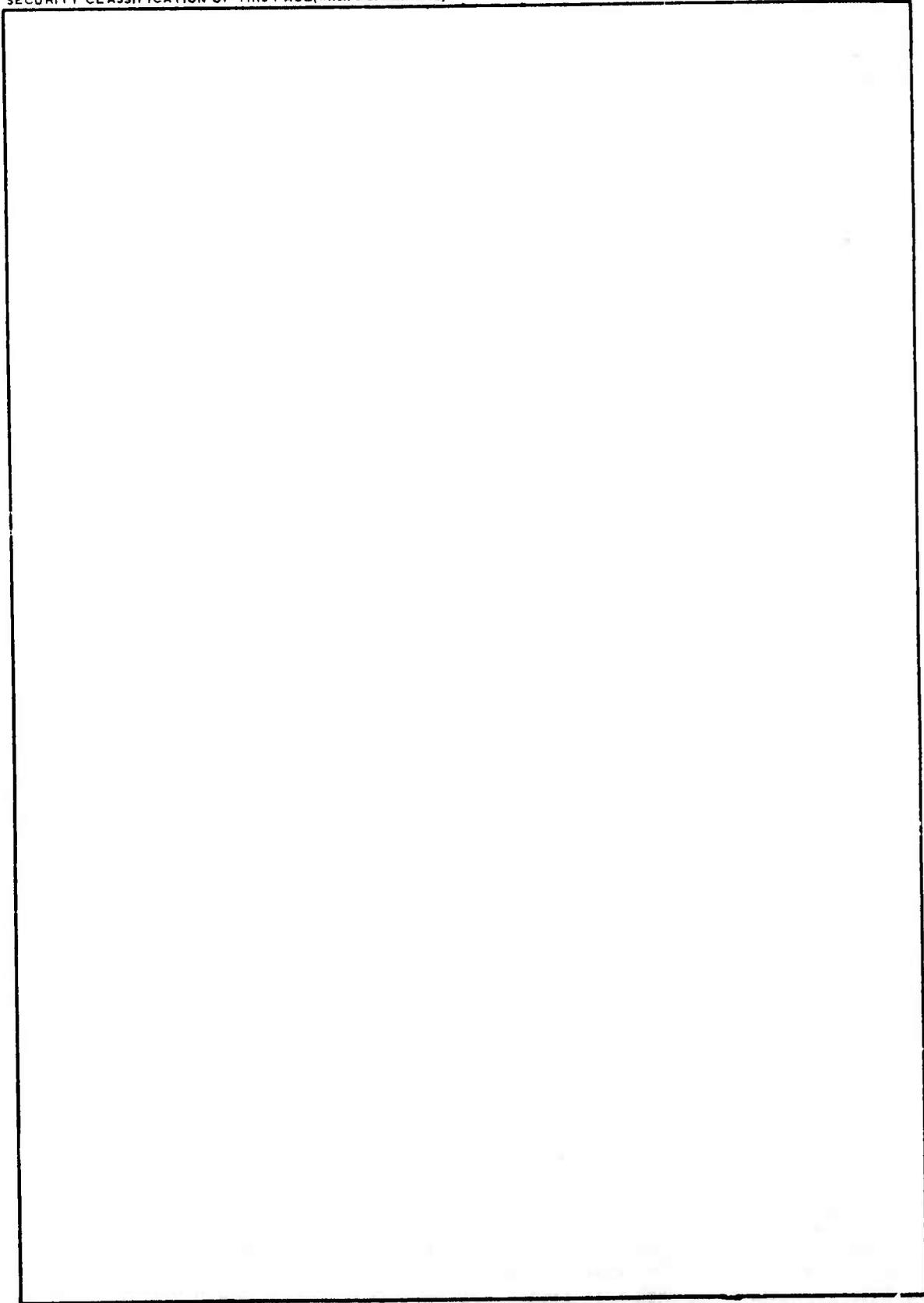

UNCLASSIFIED

SECURITY CLASSIFICATION OF THIS PAGE(When Data Entered)

SUMMARY

This report contains the results of a functional design study of the Quick Strike Reconnaissance (QSR) Reconnaissance Reporting Facility (RRF). The RRF is based on maximizing the use of currently available commercial or militarized components interfaced with the data processing equipment and software of the Imagery Interpretation (II) segment of the Tactical Information Processing and Interpretation (TIPI) system.

The study presents operational concepts, a functional data flow analysis, and alternative configurations for the presentation and interpretation of imagery. Two sensors are used to gather intelligence, and both are data-linked from the acquiring aircraft to the ground receiving station. The Forward-Looking Infrared (FLIR) sensor system is data-linked and is displayed to the RRF interpreter as composite video. The sensor data from the AN/AAD-5 infrared exploitation set is also data-linked to the ground exploitation system where a recorder/film processor is used to generate the hard-copy film in near real time.

The study presents specific equipment configurations and alternatives for both a FLIR-only RRF and an exploitation facility capable of processing both FLIR and AAD-5 sensor imagery.

All elements of the system, whether equipment components or operator tasks, were evaluated to ensure that a timely throughput of data could be attained and maintained throughout a mission.

ABOLITION for	
RTIS	
DDC	
CRIMINALS	
JUSTIFICATION	
BY	
DISTRIBUTION/AVAILABILITY CODES	
Dist.	AVAIL. CODE
B	

TABLE OF CONTENTS

<i>Section</i>	<i>Title</i>	<i>Page</i>
I	INTRODUCTION	5
	A. Mission	5
	B. Purpose of QSR-RRF Study	5
II	OPERATIONAL CONCEPTS OF THE QSR-RRF	7
	A. Operational Activities of the FLIR System	7
	1. Mission Preparation Activities	7
	2. Real-Time Mission Exploitation	8
	3. Postmission Exploitation Activities	10
	4. Functional Flow Analysis of FLIR Imagery	10
	B. FLIR Operational Activities in the RRF with AAD-5	11
	C. Operational Analysis of AAD-5 Alternatives	11
	1. Activities in Configuration 1	11
	2. Activities in Configuration 2	12
	3. Activities in Configuration 3	12
	4. Functional Flow Analysis of AAD-5 Imagery	13
III	EQUIPMENT AND CONFIGURATION ALTERNATIVES	19
	A. Applicable Elements From the TIPI II System	19
	1. Recommended Hardware Components	19
	2. Recommended and Additional Software Functions	20
	B. FLIR Equipment Alternatives	36
	1. Video Monitor	37
	2. Video Replay Unit	37
	3. Display Systems	39
	C. FLIR-Only Configuration Alternatives	41
	1. Analog Search and Interpretation	41
	2. Analog Search and COMTAL Interpretation	41
	3. Analog Search and CDC Interpretation	47
	4. CDC Digital Search and Interpretation	47
	D. Equipment/Configuration Alternatives	47
	1. Alternative 1 (Two PICs)	51
	2. Alternative 2 (One PIC, One FLIIC)	51
	3. Alternative 3 (One FLIIC, One IAC)	55
	4. Shelter Configuration Analysis	57
IV	RECOMMENDED CONFIGURATION	61
	A. RRF Equipment	61
	B. Shelter and Configuration	61
APPENDIX		
	A. Pictorial Presentation of FLIR Functions Within QSR-RRF	
	B. Capabilities and Characteristics of Recommended II System Equipment	

LIST OF ILLUSTRATIONS

<i>Figure</i>	<i>Title</i>	<i>Page</i>
1	QSR-RRF Functional Flow Analysis of AAD-5 Imagery	13
2	Recommended Components and Configuration From the TIPI II System	19
3	Initial Video Image Function Mapping	29
4	Contrast Increase in Midrange Gray Levels	29
5	Contrast Map Shifted Increasing Contrast in Lower Gray Scales	30
6	Increased Contrast in Lower 60 Percent of Gray Range	30
7	Increased Contrast in Upper 40 Percent of Gray Range	30
8	Possible TADIL-B Report Format	31
9	Possible TADIL-B Report History Queue	32
10	FLIR-Only Analog Search and Interpretation Components	42
11	FLIR-Only Analog Search and Interpretation Configuration	43
12	FLIR-Only Analog Search and COMTAL Interpretation Components	44
13	FLIR-Only Analog Search and COMTAL Interpretation Configuration	45
14	FLIR-Only Analog Search and CDC Digital Interpretation Components	46
15	FLIR-Only Analog Search and CDC Interpretation Configuration	48
16	FLIR-Only CDC Digital Search and Interpretation Components	49
17	FLIR-Only CDC Search and Interpretation Configuration	50
18	Configuration of Alternative 1	52
19	ADP Equipment Configuration of Alternatives 1 and 2	53
20	Configuration of Alternative 2	54
21	Configuration of Alternative 3	56
22	ADP Equipment Configuration of Alternative 3	57
23	Hardware Configuration of the RRF	63
24	Recommended Test Configuration of the RRF	64
25	Recommended Demonstration Configuration of the RRF	65
26	Isometric Drawing of AAD-5 Console	66
27	Isometric Drawing of FLIR Console	67
28	Prototype Fabrication Schedule	68

LIST OF TABLES

<i>Table</i>	<i>Title</i>	<i>Page</i>
1	Applicable Program Functions	22
2	Component Availability for Each Alternative	36
3	Property List Requirements for the QSR-RRF	62

EVALUATION

RADC has been tasked to provide the Quick Strike System with a real/near real time ground image exploitation station. This contract provided a design study with respect to interfacing equipment and concept configuration utilizing existing Tactical Information and Processing Interpretation (TIPI) equipment and capabilities into a Reconnaissance Reporting Facility. Results of this study are being used as design for fabrication of the RRF for delivery in 1978 to TAC for DT&E and IOT&E.

This contract defined the design requirements for the RRF which is identified as a critical item in TPO No. 1, under Image Intelligence, All Weather Day/Night Exploitation, Item A - Near Real Time Target Detection.

RONALD B. HAYNES
Project Engineer

SECTION I INTRODUCTION

A. MISSION

The Quick Strike Reconnaissance Reconnaissance Reporting Facility (QSR-RRF) will provide the capability to exploit in near real-time, FLIR and AAD-5 sensor imagery transmitted to the ground receiving station by a reconnaissance aircraft.

The basic mission of the ground exploitation facility (RRF) is to provide immediate exploitation of reconnaissance such that a target assignment and subsequent strike could occur as quickly as possible after sensor acquisition. To accomplish this task, the RRF must perform or provide the following capabilities:

1. Digital data link to a command and control center
2. Present FLIR and AAD-5 sensor imagery for interpretation
3. Provide controls to enhance presentation of the video imagery
4. Provide automated mechanical and computer interfaces to assist the interpreter in accurate and timely target detection and intelligence dissemination
5. Accurately determine target coordinates
6. Report generation and transmission capability minimizing operator interface.

B. PURPOSE OF QSR-RRF STUDY

To define the basic equipment required to accomplish the QSR-RRF mission, detailed analyses of the imagery presentation and retrieval, data base support, report composition and editing, and communication functional elements are required. This study defines the equipment and configuration required for the QSR-RRF. Sufficient analyses to justify a recommendation with respect to equipment and configuration for a prototype RRF have been included in this study. The prototype will be based on a TIPI Imagery Augmented Shelter with appropriate recommendations for equipment additions, deletions, and nonpermanent modifications.

SECTION II

OPERATIONAL CONCEPTS OF THE QSR-RRF

A. OPERATIONAL ACTIVITIES OF THE FLIR SYSTEM

The Quick Strike Reconnaissance--Reconnaissance Reporting Facility (QSR-RRF) will provide the capability to perform a near real-time exploitation of FLIR imagery transmitted to the ground receiving station.

The basic mission of the RRF is to display the composite video, transferred by the Quick Strike receiving station to the RRF, and to allow immediate exploitation of that video. Automated assistance will be provided, when applicable, to aid in the interpretation of the target, and to aid in generating the report for transmission to the appropriate command and control structure.

Within the RRF, there are two proposed types of operator functions or consoles. The first console format is the search or scan console. At this console, the operator will view the real-time imagery and upon target detection will transmit a video frame (or sequence of video frames) to the other console type. This second console type is the interpretation console at which the target is evaluated, and the report is composed and transmitted to the appropriate command and control elements. At this console, the interpreter is able to perform target mensuration.

The operational procedures of the RRF are divided into the three sections: mission preparation, real-time mission activities, and postmission analysis. Within each of these mission activities, a scenario for operational procedures will be presented.

The operational premise of the RRF is two-fold: first, to perform accurate and timely target acquisition and interpretation, and second, generation and transmission of an applicable report such that target assignment and subsequent strike action could occur within the theater concept of priorities.

1. Mission Preparation Activities

Due to the nature of the QSR-RRF concept of real-time target acquisition and reporting, considerable emphasis must be placed on mission preparation activities. The equipment in both the QSR receiving station and in the RRF must be operational as well as the data lines of communication between them. To determine the operational readiness of the RRF, a series of built-in test (BIT) functions are available to perform confidence level testing on the RRF/II common hardware. In addition to these BIT tests, operational readiness functions are initiated to perform confidence level testing on the hardware and communications lines of the video system. When the equipment status has been verified, the QSR-RRF supervisor may initiate the activities that pertain to the mission exploitation itself. Since the requirements of support data vary with the mission, the supervisor must review the frag order or tasking directive for that mission in conjunction with the mission flight schedule.

From these sources, the supervisor will determine the geographic coordinates which will encompass the area covered by the FLIR mission. These coordinates will be used to search the digital data base and retrieve related multisource intelligence data, any previous interpreter

reports, and the digital map initialization parameters required for the aircraft tracking displays. This data is stored in the form of a data package in the magnetic tape. Prior to mission exploitation, the data will be transferred to each station. An index to the maps required for the aircraft tracking display is printed for the use of the supervisor. The supervisor uses the map index printout to collect and distribute the required maps to the search/scan consoles. The digital map initialization parameters are used to automatically initialize maps on the tracking displays. Each operator reviews the digital intelligence data prior to mission exploitation. The supervisor will verify that the communications data link between the RRF and the command and control center is operative.

2. Real-Time Mission Exploitation

Before receiving the FLIR video, the search console (SC) operators will review the tasked objectives and associated hard copy materials, review the proposed flight track, and initialize the search system and mapboard displays. As the FLIR video is received, the ADAS data will be used to perform aircraft tracking on the map initialized. As the mission progresses and the aircraft moves from map to map, the SC operator will mount the appropriate map on the map board and initialize it. The SC operators will monitor the incoming video searching for targets of opportunity, targets of interest, and designated (fragged) targets. When a target is detected, the SC operator will terminate the recording of the FLIR data by pressing a FREEZE interrupt button. This will allow the ADAS data to be correlated with the 20-second FLIR history available for playback. After pressing the FREEZE button, the SC operator will replay the video history and select the best frame or sequence of frames and initiate the transfer of this FLIR data to the interpreter's console for further analysis. The FLIR parameters corresponding to the transferred FLIR video will also be transmitted to the interpreter's console. The search console operator, after performing the image transfer, returns to the search/scan mode to continue scanning the incoming video in parallel with the other search/scan console.

The following list summarizes operator functions at the search console:

- Activate FLIR data receiver and map tracking

- Replace map as required and reactive tracking

- Use the three interrupt buttons to control FLIR video

 - FREEZE—stops recording, uses video recorder controls to replay 20-second history

 - TRANSFER—sends frame(s) to interpreter

 - RESTART—resumes FLIR video search.

On completion of the image transfer by the SC operator, the interpreter's query response/report composer unit (QR/RCU) display will present the status flag IMG, indicating that an image is available for interpretation. The interpreter used the Queue Review/Image Selection function. Through this function the interpreter will have a list of all frames (or segments) that the SC operators have transmitted, the time the image was transferred, and status flags to indicate the previously interpreted frame sequences. Through this function, the operator may select the next time sequential video image or select sequences out of order. After selecting the appropriate se-

quence, the video will be displayed on the monitor for interpretation. At this point, the operator has several options available which all depend on the sensitivity or characteristics of the target and the amount and type of data required to properly report the target.

Some of the available options are as follows:

If no further information is required other than the FLIR boresight coordinates, an appropriate report may be generated and transmitted to the TACC immediately.

To perform off-boresight target location or other mensuration tasks, the operator must initialize the video frame by pressing the video frame initialization program select button (PSB) and verifying the boresight coordinates. Following initialization, the operator determines target location by pressing the MENS PSB, selecting the target location option, placing the cursor with a joystick or track ball interface, and pressing the *cursor enter* interrupt button. The resulting coordinates will be displayed in both geographic and UTM coordinate systems.¹ These results (as well as other mensuration answers) are digitally available during the report generation phase of interpretation. Other mensuration tasks are performed as easily as target location. For example, FILM DISTANCE and AZIMUTH. Pressing the MENS PSB, the corresponding option is selected (1 second). Position the video cursor at first point and press the cursor enter button (1 to 5 seconds). Position the video cursor at second point and press the cursor enter button again (1 to 5 seconds). The distance in feet, meters, and nautical miles is displayed and the azimuth from point 1 to point 2 is displayed (1 second). These results are also available digitally during report generation. Total time, which obviously depends on the target and operator experience, may vary from a minimum of 4 seconds to probable maximum of 15 seconds.

By executing the Navigation Correction function, the level of confidence and accuracy of target location readouts may be increased. The Navigation Correction function requires the input of geographic coordinates of some known point on the FLIR video display.

Once the operator has identified the target and is satisfied with his interpretation and coordinate readout, the interpreter generates the report via the QR/RCU keyboard and presents the report to the targeting officer for verification and release. If the format is a TADIL-B report, then upon indication, the report is placed in the TADIL-B transmission queue. If a different reporting format is required, the report following the edit process is entered into the communications header queue. In this queue, a standard JANAPS-128D or ACP-127D communications header is attached and the report is placed into the TTY/DDI communications transmission queue. The interpreter then continues by acquiring the next target available for interpretation.

This process of real-time video scanning, target detection and interpretation, and rapid intelligence dissemination continues until the FLIR mission is completed.

¹ If loran conversions are integrated as part of the RRF, then the loran TDs will also be displayed.

3. Postmission Exploitation Activities

As the FLIR mission is in progress, the video and tracking data signals are being recorded on tape in the ground receiving station. After the real-time exploitation has been accomplished, the tape can be replayed and interpreted for any significant changes in static targets covered by the mission.

The interpretation function is very similar to the real-time interpretation process. As the video and tracking data are received by the search/scan consoles, both consoles are in a search/scan mode until a FREEZE is required as in the real-time analysis.

The search/scan operators have the capability of playing and replaying any segment of the mission. The tasking directive EEs concerning static targets will be answered at this time. When a target is detected, the operator will perform an image freeze of the video and transfer the best video presentation of the target image to the interpreter's storage unit. The search/scan operator then continues scanning the video tape for additional intelligence.

Upon completion of the image transfer, the interpreter's QR/RCU display will present status flag IMG, indicating that an image is available for interpretation. The operator then selects the image for viewing and selects the report composer program. The operator has the same options available to him during the interpretation, report composition and editing process as outlined under the previously described real-time exploitation cycle. Upon completion of each report item it is sent to the report edit queue. These report items are then merged into a single intelligence report which is designated for transmission; a communications header is then attached and the report transmitted to the command and control center.

4. Functional Flow Analysis of FLIR Imagery

Appendix A provides a pictorial presentation of the FLIR functions occurring within the QSR-RRF. These tasks are organized into six functional areas of operation: RRF initialization, mission preparation, mission search/scan mode, final target interpretation, report generation and dissemination, and detailed analysis and postmission update. Each basic functional area consists of a grouping of those specific functions that occur within the QSR-RRF.

There are two levels of detail used for presentation of these flows (Appendix A): the general first level and the more detailed second level. The first level flow depicts the general functions of the six functional areas as they occur within the QSR-RRF. The second level flow contains blocks representing the specific functions and decisions within the general functions that need to be accomplished.

The functional flows presented define the basic tasks of the QSR-RRF. Functional areas 1 through 5 define in detail the task of providing immediate exploitation of FLIR video and ADAS signal reconnaissance data for the purpose of immediate target assignment and subsequent strike. Functional area 6 defines the intelligence option available within the QSR-RRF for exploiting the FLIR data recorded on video tape for the purpose of extracting and disseminating additional intelligence information as well as retaining and utilizing this data for QSR-RRF digital data base updates.

The initial flow diagram in this document is an introductory overview of the functional areas comprising the QSR-RRF. Each of the functional areas presented in this flow diagram (Appendix A) is later presented in terms of the two levels of detail.

B. FLIR OPERATIONAL ACTIVITIES IN RRF WITH AAD-5

The previous description of FLIR real-time exploitation is sufficient for a FLIR-only system. When, however, AAD-5 imagery is actively being exploited, one of the computers is dedicated to supporting the AAD-5 light station while the remaining computer can support two FLIR interpreters. These two FLIR interpreters each have a video monitor and must together support the FLIR intelligence activity. Characteristics of the video system dictate that a video transfer cannot occur while a PI is interpreting a target. To do so would disrupt the video image being analyzed by the interpreter. Since this situation cannot be tolerated, an alternative is to allow each station to act as a target detection and target interpretation station. With verbal coordination and use of the variable record/playback rates of the video recorder, a potential loss of real-time imagery could be eliminated with no disruption of the video interpretation. This concept will be discussed again with respect to configuration alternatives in Section IV.

C. OPERATIONAL ANALYSIS OF AAD-5 ALTERNATIVES

To adequately describe the AAD-5 operational activities, it is necessary to introduce three possible configuration alternatives. Briefly, Configuration 1 has two photointerpretation consoles (PICs) and three FLIR video monitors. With this system, off-boresight mensuration is improbable due to limitations of core memory in the computer. Configuration 2 presents one PIC and a forward-looking infrared interpretation console (FLIIC). Configuration 3 presents the same FLIIC, but the compass light table is replaced by a simplified viewing surface, and the PIC is simplified to provide an in-line film flow.

In the latter two configurations, off-boresight mensuration is included in the operational scenario since core memory is made available through the use of only one AAD-5 interpretation console. The first two configurations use the PIC that is currently available for testing in the RRF. It is for this reason that the PICs are considered despite the fact that they are oversized for the Quick Strike application.

1. Activities in Configuration 1

Configuration 1 uses a compass sight (CS) light table (or an alternative) to perform target detection. Following the detection of targets on a strip of imagery, a second operator at the CS light table would cut the film into strips, recording identification of the strip on both the film and in a log. This strip of imagery would then be available to the interpreters positioned at either of the two PICs for final interpretation and report generation and dissemination. Manpower requirements of this configuration are significant in that it requires five people to perform the Quick Strike AAD-5 function. The five include one for target detection, one for film strip isolation and distribution, two for target identification (one for each PIC), and a targeting officer with releasing authority.

The above analysis coupled with a functional evaluation of the RRF using both FLIR and AAD-5 sensors, indicates that four of the five positions would have little time to perform FLIR

targeting and reporting. The fifth position (at a PIC) could provide most of the FLIR targeting, but necessitates the addition of a sixth person. It quickly becomes evident that this configuration is not operationally desirable: (1) AAD-5 interpretation, and FLIR targeting and reporting are performed at both ends of the shelter, (2) the number of personnel required to support the mission becomes critical due to space limitations, and (3) it has not been shown that two interpretation consoles for the AAD-5 imagery is a requirement. In fact, a functional timing analysis for the throughput of AAD-5 imagery indicates that one interpretation station is sufficient for most areas imaged. These observations form the basis of Configuration 2.

2. Activities in Configuration 2

In Configuration 2, one PIC is replaced with a FLIR video interpretation console (FLIIC). At this console, two FLIR interpreters share the target detection and reporting responsibilities. Either interpreter may act as the search/target detection operator while the other performs interpretation tasks, or each may function independently performing both tasks (detection and interpretation) with verbal coordination to minimize or eliminate the loss of real-time FLIR acquisition. The latter concept is operationally more feasible since the analog display of video depends on the interpreter's recorder. In other words, while the interpreter is performing his function, the search video station cannot transfer the next target to the interpreter's recorder without disturbing the interpreter's video display. The third FLIR video display, located at the opposite end of the shelter, would be required during a FLIR-only exercise or during any time when there is no AAD-5 imagery to evaluate. The AAD-5 imagery would be detected by an operator on the compass sight light table or its alternative. Once detected, the film strip would be given to the PIC operator for final interpretation and report generation. As with the previous configuration, the AAD-5 film must be cut to use the film in the PIC. Thus, an operator is required to perform the film isolation and distribution. The personnel requirements of this configuration are still significant. The advantage of Configuration 2 over Configuration 1 is that FLIR interpretation in the Quick Strike scenario is now a feasible operational concept. However, the AAD-5 flow is still unjustifiably cumbersome. The only method that allows the streamlining of this film flow is the reorientation of the PIC (or a derivative) such that the film would flow in straight lines (uncut) from the AAD-5 film recorder/processor to the interpreter, as in Configuration 3.

3. Activities in Configuration 3

The FLIR detection/interpretation scenario remains the same for Configuration 3. The responsibilities of detection and interpretation are mutually shared with verbal coordination to ensure real-time target acquisition instead of mission playback acquisition. The AAD-5 detection/interpretation process is optimized to eliminate the previous necessity of cutting film and it also eliminates the operator that cuts and distributes film. The imagery flow is then continuous, which maintains the shortest film path length to minimize the delay in passing detected targets from the detection light surface to the interpreter's light surface. To compensate for the variance in activity speed between the processor, the detector, and the interpreter, each element has independent film drive electronics. Excess film is collected in a temporary holding box or slack loop box between the three elements. Following the interpretation, the film is collected on a take-up reel. While performing in a full-up configuration with both FLIR and AAD-5 sensor imagery being data-linked, the personnel requirements would include: one targeting officer, two FLIR detectors/interpreters, one AAD-5 film target detector, and an AAD-5 film interpreter.

During very heavy loading of film processing, the USMC showed during the Category II test of the TIPI II Segment that two operators could more effectively and more efficiently use the interpreters light table and keyboard elements. In this configuration, the interpreter would concentrate on the film and its interpretation, allowing the second operator to use the keyboard in directing the computer interface. This configuration was shown to be effective and should be included for evaluation during the IOTE of dense-target AAD-5 film acquisition.

4. Functional Flow Analyses of AAD-5 Imagery

This subsection illustrates the information and data flow associated with the interpretation of AAD-5 imagery. Figure 1 shows the top-level events required to detect, interpret and report on AAD-5 targets.

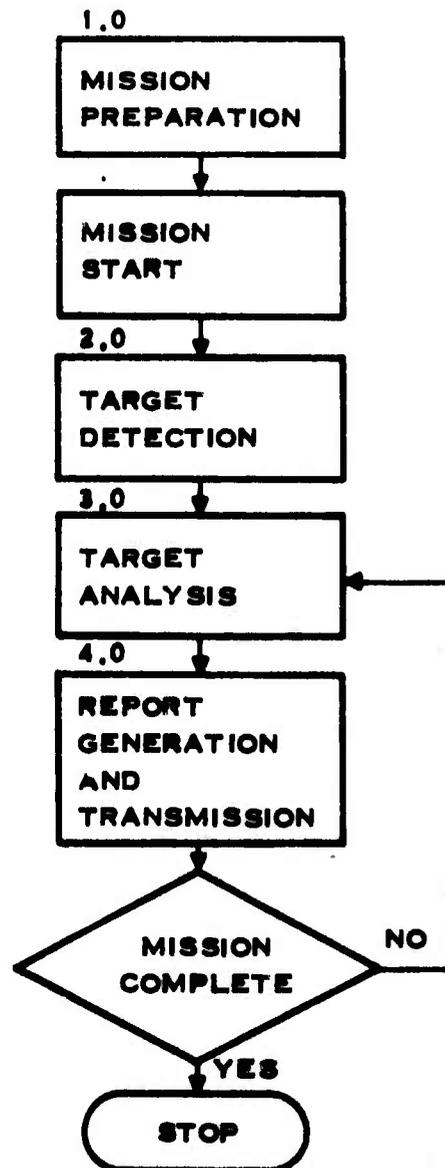

196352

Figure 1. QSR-RRF Functional Flow Analysis of AAD-5 Imagery (Sheet 1 of 5)

1.0 MISSION PREPARATION

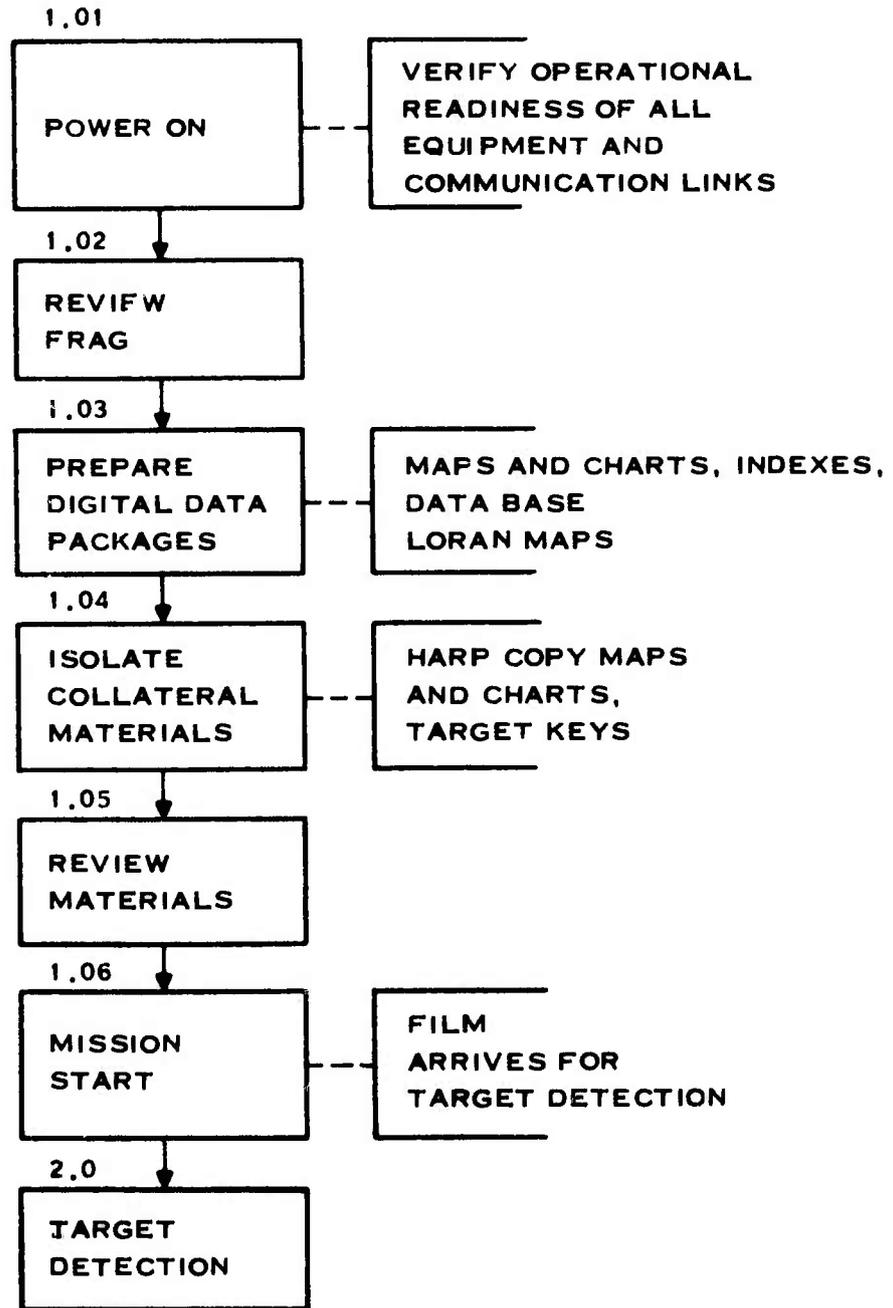

196353

Figure 1. QSR-RRF Functional Flow Analysis of AAD-5 Imagery (Sheet 2 of 5)

2.0 TARGET DETECTION

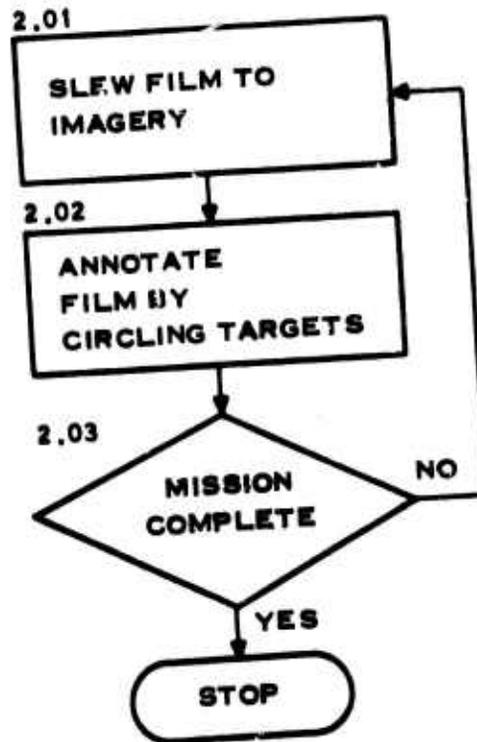

196354

Figure 1. QSR-RRF Functional Flow Analysis of AAD-5 Imagery (Sheet 3 of 5)

3.0 TARGET ANALYSIS

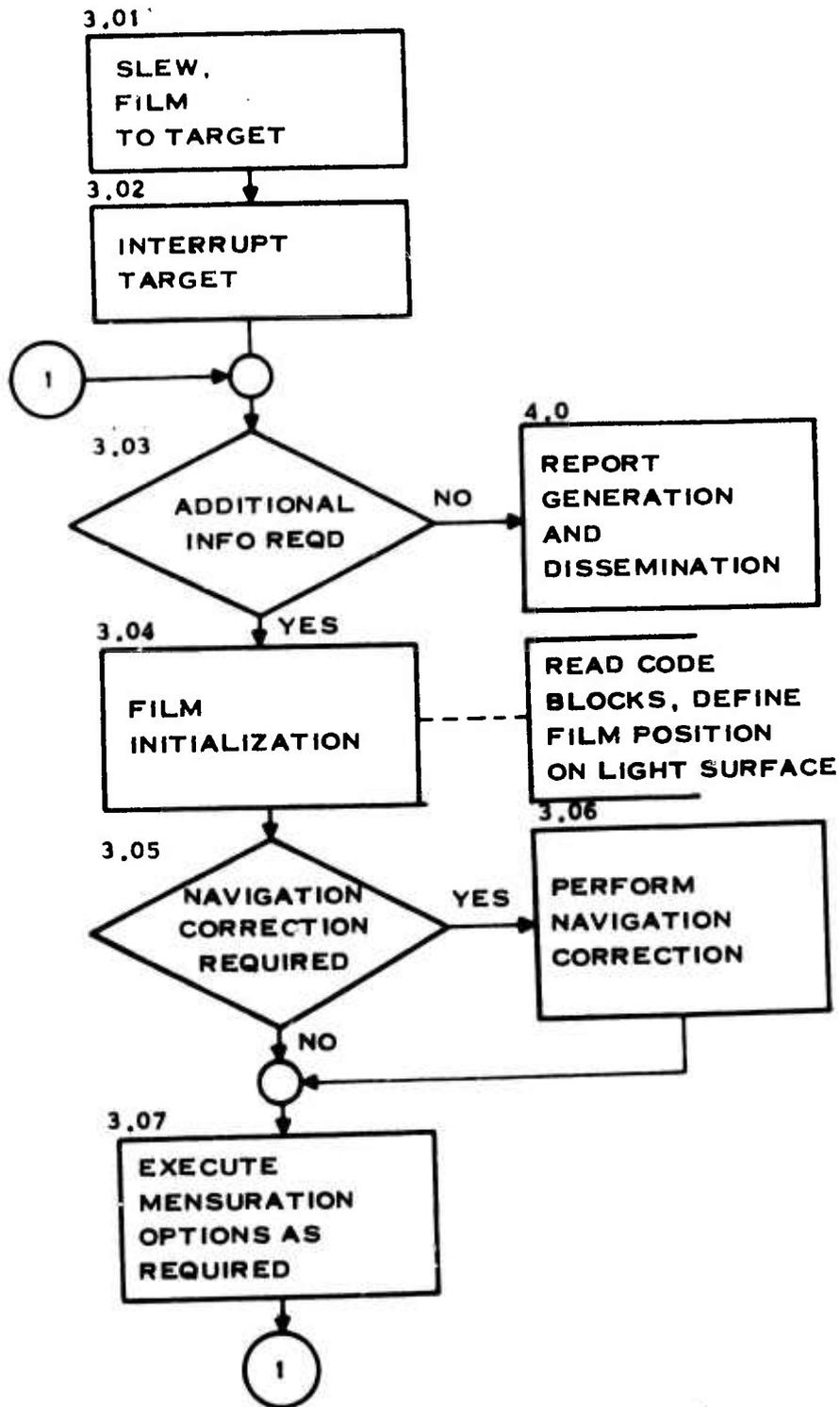

196355

Figure 1. QSR-RRF Functional Flow Analysis of AAD-5 Imagery (Sheet 4 of 5)

4.0 REPORT GENERATION AND TRANSMISSION

4.01



4.02



4.03



4.04



USE HELP, ADI SPLIT SCREEN

4.05

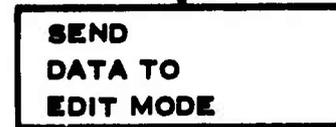

4.06



TARGETING OFFICER VERIFICATION

4.07

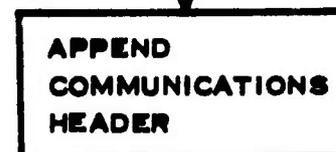

ACP-127D OR JANAP 128D

4.08

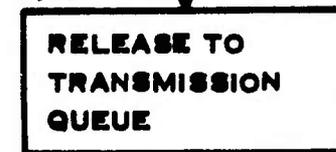

3.0

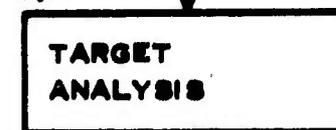

(1) TADIL-13

4.11

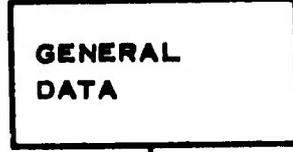

USE HELP AND SPLIT SCREEN

4.12



3.0



196356

Figure 1. QGR-RRF Functional Flow Analysis of AAD-5 Imagery (Sheet 5 of 5)

SECTION III
EQUIPMENT AND CONFIGURATION ALTERNATIVES

A. APPLICABLE ELEMENTS FROM THE TIPI II SYSTEM

The Imagery Interpretation Segment of the Tactical Information Processing and Interpretation (TIPI) contains hardware and software that is directly applicable to the concept evaluation and implementation of the QSR-RRF. Figure 2 illustrates the component configuration of the recommended applicable II segment hardware.

1. Recommended Hardware Components

The following II segment equipments are recommended for use in the evaluation and implementation of the QSR-RRF. Appendix B provides a description of the capabilities and characteristics of recommended II system equipment:

- a. Central Processing Unit—Executes II system software and provides the interface between all peripherals, the operator, and digital support materials.
- b. Query Response/Report Composer Unit—Provides the interface between the operator and the data processing system. Special program select buttons (64) allow the operator to control, direct, and interrogate the data processing system.

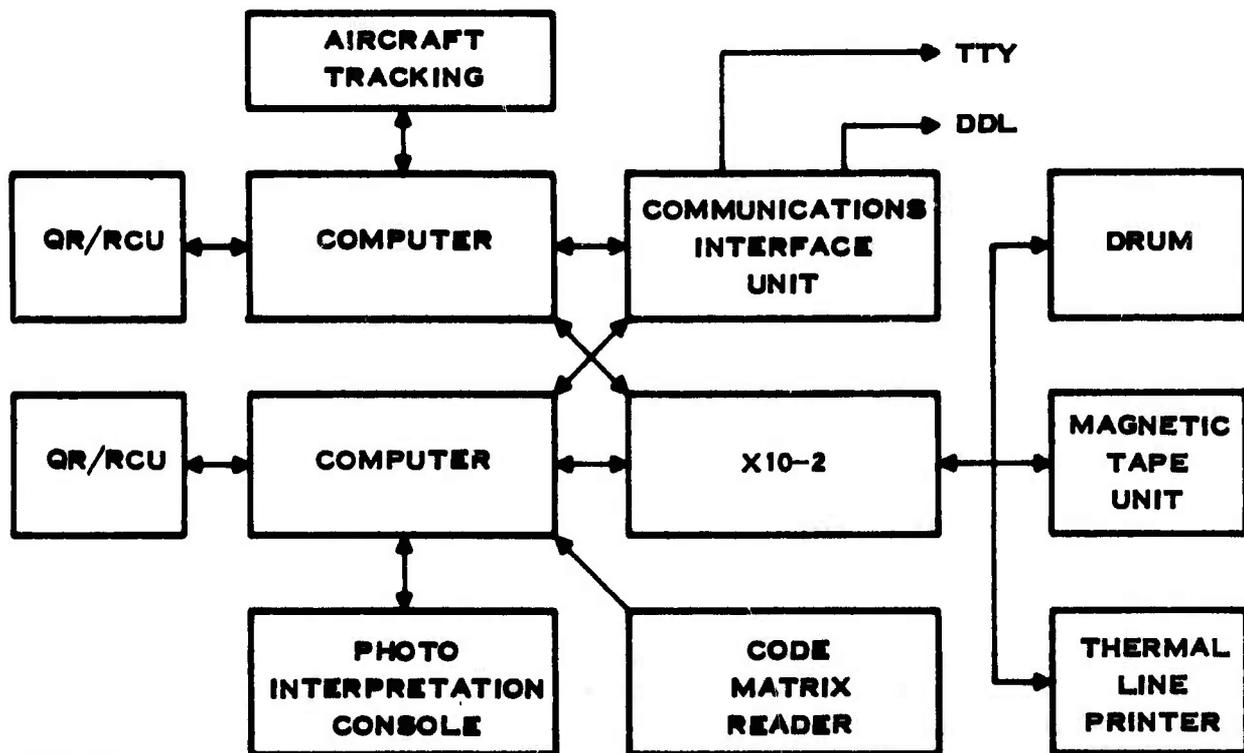

196357

Figure 2. Recommended Components and Configuration From the TIPI II System

- c. Drum—Storage for software programs that are dynamically accessed during systems operation. The drum is also used to store reports that are created and to maintain other support data files such as ADAS information and navigation correction tables.
- d. Extended Input/Output Unit—Digital switch and controller for all peripherals such as the drum, computer, magnetic tapes, and printer.
- e. Printer—Provides hard copy prints of all reports generated by the segment as well as printing of data base information and index to hard copy data for access of maps.
- f. Magnetic Tape Unit—One magnetic tape is sufficient to store and retrieve required systems information and operational data files. The II segment data base requires two magnetic tape drives. The use of a data base in the RRF offers considerable advantages over an RRF with no data base. Thus, two magnetic tape drives are recommended for the QSR-RRF prototype evaluation.
- g. Map Tracking Display—Provides automatic aircraft tracking. Up to 200 independent maps may be initialized at one time and mounted as required to perform map tracking, map distance, and azimuth and target location.
- h. Photo Interpretation Console (PIC)—Supports and assists the interpreter, by mechanization and automation, in accomplishing the following operations:
 - View film transparencies, maps, and overlays
 - Communicate with the digital computer current status and activities and respond to data requests and directives.
- i. Code Matrix Reader (CMR)—The CMR is an automated system that senses the density variations in a MIL-STD-782C code matrix block as annotated on film. This information is digitally passed to the computer for imagery exploitation.

2. Recommended and Additional Software Functions

Software programs in the II segment can be divided into two general classes: those requiring operator interface (e.g., report composition), and those not requiring operator interface (e.g., device service routines). Operator interfaces are accomplished through a series of instructions and keyboard data inputs to the QR/RCU. The software accepts these inputs and performs the indicated response or action. The following paragraphs describe the operator interface functions available in the II segment that pertain to the QSR-RRF. In addition, a description of the modified functions and new functions and capabilities are presented. Table I provides a list of applicable functions indicating whether they are modifications to existing software or new functions.

a. Existing or Modified Functions

(1) Status Controller

Initiates the execution of the appropriate built-in test (BIT) routine as selected from the status selection list. The BIT function provides confidence level testing to determine the operational status of the hardware and the operational requirements imposed on that hardware. BIT functions recommended are (* implies the function is currently available) as follows:

- *Digital computer
- *Multiplexer
- *Drum
- *Query response/report compose unit
- *Thermal line printer
- *Magnetic tape transports
- *Code matrix reader
- *Map and film cursor
- Search/scan freeze interrupt
- Remote recorder control (manual and automatic)
- Video image transfers
- Interpreter console (including video cursor)
- *Communications BIT (TTY, DDL, and/or TADIL-B).

(2) Station Initialization

Initializes station variables and mission data items. Station and mission variables include the following:

- Systems time and date
- Operators name
- Project/mission identification
- Classification
- Organization.

(3) Station Release

Releases the consoles upon completion of a mission by zeroing common memory and deleting mission related files from the drum.

(4) Data Disposition

Enables the operator to create a standard routing file which specifies the disposition of individual data files. It provides for the control of devices and data queries through the specification of activate, deactivate, or abort.

(5) Format Generation

Generates recallable report formats. These formats may have automatic data insertion (ADI) and format field definition (HELP) capabilities, and are used by the Report Composer program in composition of reports.

TABLE 1. APPLICABLE PROGRAM FUNCTIONS

Program/Function	Modifications Required or New
Status controller	New
Station initialization	
Station release	
Data disposition	Mod
Format generation	
Report composer	
Report edit	
Communications header	
Photo interpreter's reference file (PIRF) maintenance	
PIRF review	
Multisource intelligence file (MIF) select	
Imagery analysis data (IAD) generation	
IAD retrieval	
Automatic data insertion	
Splits	
Coordinate conversion and display	
Tasking directive review/reformat	
HELP	
MOVE TO	
Print QR/RCU	
Drum file copy	
Drum copy	
System editor	
Map initialization	Mod
Search console freeze/transmit/restart	New
Interpreter queue review/image selection	New
Video image initialization	New
Navigation correction	Mod
Target data review	Mod
Priority point detection	Mod
Mensuration	Mod
Video image enhancements	New
TADIL-B interface	New
Loran time differences	New

(6) Report Composer

Allows the operator to compose reports according to predefined formats. Capabilities exist for automatic data insertion (ADI) and format field definition (HELP). HELP and ADI features for predefined formats will have been previously defined in the Format Generation program. Report Composer provides the operator with the option to: create individual report parts; review the report or selected parts; reorder items within a part; delete parts or single items; continue working on an existing part after exiting and re-entering the Report Composer program; and transmit completed reports or reported parts for editing.

(7) Report Edit

Provides complete editing capabilities for the review of reports prepared with the Report Composer program. Capabilities exist for the format field definition (HELP). Report Edit provides the operator with the following options: to edit and merge report parts, to review the entire report or selected parts, to reorder items within a part, to delete parts or single items, or to transmit completed reports to the Communications Header program. If the item being reviewed has a particular image associated with it, then the image should be displayed on the interpreter's console display. The option to annotate and record the image for hard copy can be accomplished while the item is displayed.

(8) Communications Header

Enables the operator to generate communication header data for a file (report) to be sent, including edit of the communication header data and the inclusion of appropriate addresses; generate a new addressee file; and review, add, delete, or modify data already contained in an existing address file. Header formats available are JANAPS-128 and ACP-127.

(9) Photo Interpreters Reference File Maintenance

Formats data base magnetic tapes, generates an exclusion file for IPIR/SUPIR reports, updates the MIF/IIF data base files, purges the MIF/IIF data base tapes of obsolete data records, and provides an IAD package directory for display and/or update as required.

(10) Photo Interpreters Reference File Review

Allows the operator to review MIF and IIF data records; it also allows the operator to create digital IHC records for maps and charts and allows the operator to create digital data required for Tracking Display Map Initialization.

(11) Multisource Intelligence File Selection

Allows operator to define internal MIF descriptors which are used with the associated data elements when the MIF records are displayed on the QR/RCU.

(12) Imagery Analysis Data Generation

This function specifies area and target search parameters for the generation of digital IAD packages. Area parameter specifications consist of circle, corridor, and polygon. Target parameter specifications consist of the following:

- BE Number
- Functional classification code
- Country code
- Status code
- SRL priority.

(13) Image Analysis Data Retrieval

Retrieves the Imagery Analysis digital data package for a single mission. The content of the IAD package is determined during IAD generation. The data retrieved contains mission related MIF, IIF, maps and charts, and frag or tasking directive information.

(14) Automatic Data Insertion

Allows the automatic insertion of predefined data into report formats upon operator command. Data fields which will have ADI capabilities are defined during the format generation of a report format.

(15) Splits

The Splits function allows the operator to display data in the last six lines of the QR/RCU for the following functions:

- Priority Point Detection
- Report Composer
- Target Data Review
- Report Edit
- Navigation Correction.

The following types of data are displayed:

- Target Lists
- MIF data/IIF data
- Mensuration past answers
- Coordinate conversion past answers
- HSD display map coverage list
- Image display coverage list.

(16) Coordinate Conversion and Display

Allows the operator to input geographic coordinates via the QR/RCU and convert them to UTM or UPS coordinates, and vice versa.

(17) Tasking Directive Review/Reformat

Allows the operator to review digitally received frags, review and incorporate updates to these frags, creates digital frags from hard copy inputs, and prints the frag or a subset of it.

(18) HELP

Format field definition is an operator aid provided to define the content and format of data fields in the Station Initialization, Report Compose, and Report Edit programs. HELP definitions are displayed in the lower six lines of the QR/RCU display and are defined during the format generation phase.

(19) MOVE TO

Allows the operator to move variable data on the QR/RCU screen from one specified field in the screen to another specified field screen. MOVE TO is available in the programs which have the split screen capability.

(20) Print QR/RCU

Allows the operator to print the contents of the QR/RCU screen.

(21) Drum File Copy

Allows the operator to save drum files (such as routing files, report, and HELP definition files, etc.) on a magnetic tape or copy files from a magnetic tape to driver.

(22) Drum Tape Copy

Allows the operator to record the working area contents of the drum on magnetic tape and read this data back to the drum.

(23) System Editor

Constructs and updates function files on the drum and shall assign functions to specific pushbuttons on the program select panel. The editor performs the following functions:

Add a program from magnetic tape

Delete a program from file

Assign the entry name to a pushbutton

Copy drums to mag tape or mag tape to drum
Display master drum dictionary
Display build list dictionary
Perform end-of-edit process.

(24) Map Initialization

Allows the operator to generate map, chart, and map substitute constants for graphics currently on the map board. Up to two maps can be initialized at one time. Any number of "second" maps may be initialized and one may return to the "first" map at any time. This option also allows the operator to define the constants for up to 200 area maps for use in flight path tracking.

(25) Film Initialization

Allows the operator to generate initialization constants for the AAD-5 film. Image initialization must be performed before navigation corrections can be accomplished and prior to any readout of target coordinates or other mensuration tasks.

(26) Navigation Correction

Enables the operator to build correction data for a given mission. This correction is applied to the displayed image when performing coordinate readout or cursor positioning functions.

(27) Target Data Review

Uses the IAD data to build a file of mission oriented targets satisfying a set of criteria specified by the operator and displays the file on the QR/RCU for review. Selection parameters consist of the following:

- Circle/point
- Polygon
- BE Number
- Functional classification code
- Country code
- Status
- AAD-5 film or FLIR frame coverage
- SRL priority.

Selection parameters requiring coordinate input may be specified manually or from the video image display, map cursor, or the film cursor.

(28) Priority Point Detection

Enables the operator, via computer control, to drive the image display (video or AAD-5), or tracking display cursor, or both to a given geographic image point. The geographic coordinates for this point may be defined by the present position of either cursor, by input from the QR/RCU keyboard, or by data accessible through the Split Screen function. Regardless of the source of input data, the program will compute and display on the QR/RCU both the GEO and UTM of the point.

(29) Mensuration

Allows the operator to perform the following measurements and calculations using the FLIR video imagery:

- Film distance and azimuth between points on the video imagery or on the moving map display
- Scale determined of the video image displayed
- Vertical height of objects
- Area and volume of objects on the video imagery
- Target location (coordinates) of points on either the video or map display.

The following procedures are available using AAD-5 imagery:

- Film distance and azimuth
- Scale and altitude
- Map distance and azimuth
- Vertical height
- Area
- Volume
- Target location—map or film
- Space resection
- Stereo height.

Past answers (up to 13) are retained and are available for review via split screen in other functions such as Report Composition.

In addition, any coordinates determined may be indicated for automatic data insertion into the TADIL-B report format.

b. New Functions

(1) Search Console Freeze/Transmit/Restart

Three interrupt button interfaces from the control panel to the computer will allow the Freeze, Transmit, and Restart functions to be implemented. During video scan, depression of the

FREEZE button generates a stop command to the recorder and correlates the received ADAS data with the 20 seconds of video images. The operator, using the manual remote control panel for the recorder, reviews the video and selects an image to be transmitted to the interpreters console. Depression of the TRANSMIT interrupt button causes the video image to be recorded on the interpreters recorder. When all images required from this 20-second history have been transmitted, the search operator continues real-time scan procedures by pressing the RESTART interrupt button. In the all analog configuration, the TRANSMIT interrupt button will initiate the transfer of a continuous video image to the interpreters console. Depression of the TRANSMIT interrupt button a second time terminates the transfer. The FREEZE and RESTART interrupt buttons retain the same characteristics as in the analog/digital configuration.

(2) Interpreter Queue Review and Image Selection

Provides the interpreter/supervisor with a list of video images available for interpretation. The contents of each queue entry should contain, as a minimum, the following information:

Video frame number

Time in hours, minutes, and seconds the image was transferred from the search station to the interpreter

The time the report was completed and transmitted from the RRF

Free text comments of at least 25 characters.

The first three information elements are automatic entries.

Through this function, the interpreter is allowed to select for interpretation the next video image (time sequential) or any video image out of sequence. Also through the selection or indication of a video frame, the interpreter is allowed to slew the HSD to the nadir of the aircraft or boresight coordinates if previously initialized. Other desired functions include:

Display FLIR parameters of image

Delete video frame entry

Delete entire video queue

Print the video queue.

(3) Video Image Enhancements

Available only with the COMTAL interpretation station as defined in the FLIR-only configuration. To ensure rapid evaluation of the target and transmission of the resulting report, video enhancements must have minimal human interface requirements with maximum effectiveness. The following video enhancement procedure is recommended as the simplest and most effective.

Upon selection of the video image display, the track ball cursor shall be activated in the enhancement mode. Manipulation of the cursor will result in an updated video image. The cursor movement will result in two general image modifications: increase/decrease contrast and moving contrast emphasis between the gray scale extremes.

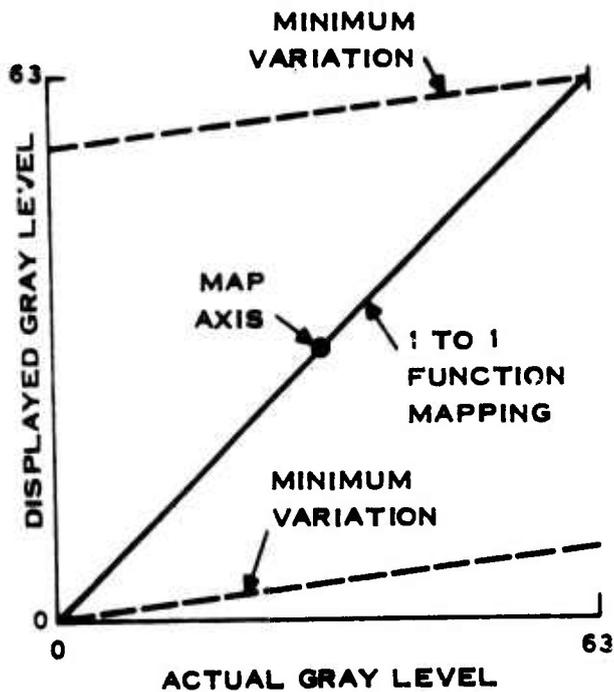

196358

Figure 3. Initial Video Image Function Mapping

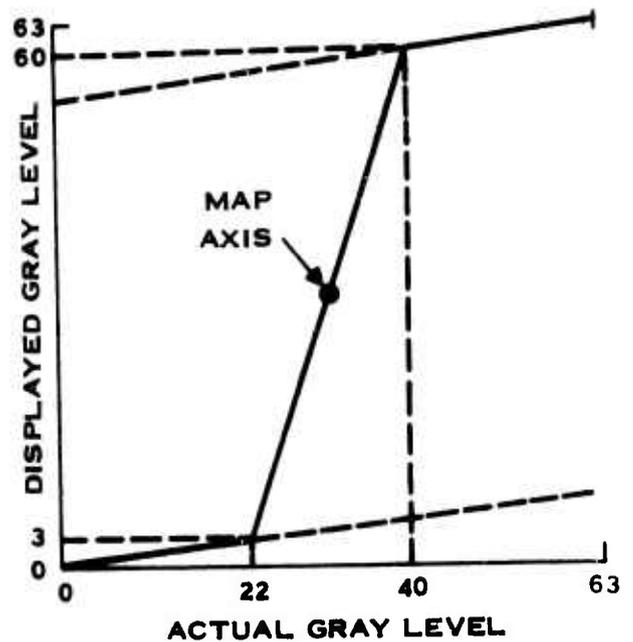

196359

Figure 4. Contrast Increase in Midrange Gray Levels

Figure 3 represents the function mapping used for the initial display of each video image. The dotted lines indicating minimum variation are not used in the initial display but are limiting contrast functions used when the contrast of the image is increased. Figure 4 shows the result of vertical movement in the track ball cursor. Increased contrast in the midrange gray values is the result. Gray values originally in the range 22 to 40 are translated through the mapping function and displayed over the gray scale range 3 to 60. Movement of the cursor in the vertical direction increases the contrast by rotating the mapping function about the map axis. Opposite movement of the cursor will result in the opposite rotation about the axis and would eventually return the mapping function to its original 1:1 aspect.

To obtain increased contrast in gray scale ranges other than the midrange area, horizontal movement of the cursor will shift in the appropriate direction the map axis of the function mapping. Movement of the cursor in one direction will increase the contrast in the lower gray levels while cursor movement in the opposite direction will increase contrast in the upper gray levels. Figure 5 illustrates the resulting map when increased contrast in the lower gray scales are derived from horizontal cursor movement using Figure 4 as the initial mapping.

Figures 6 and 7 illustrate other map functions available through continued movement of the map axis and contrast functions.

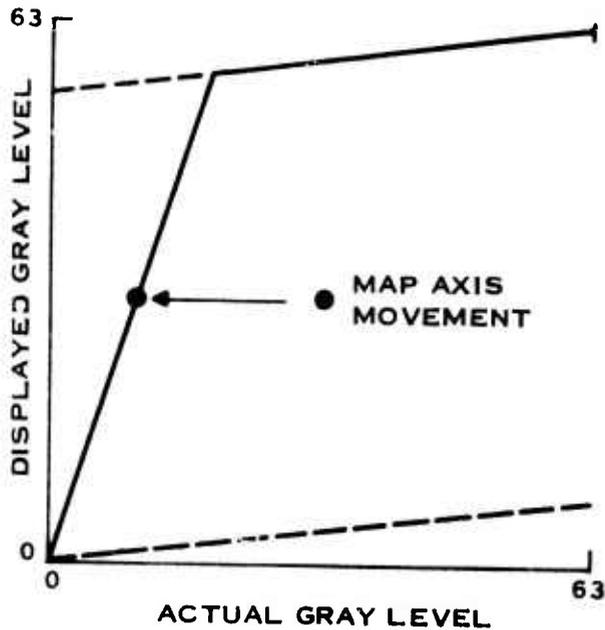

196360

Figure 5. Contrast Map Shifted Increasing Contrast in Lower Gray Scales

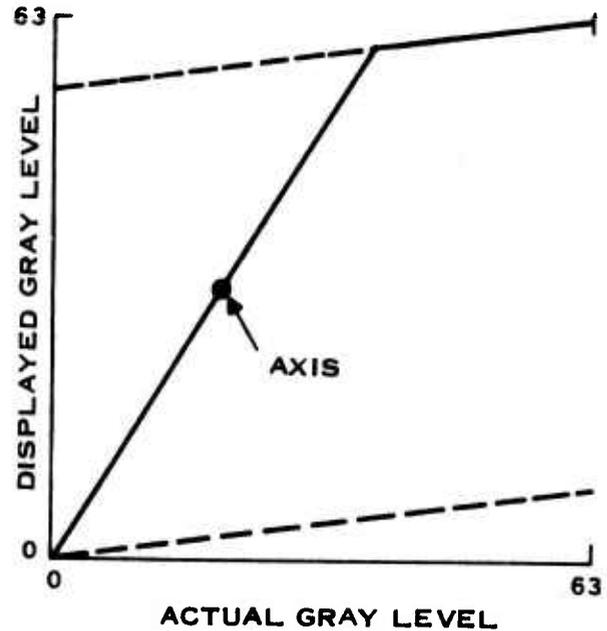

196361

Figure 6. Increased Contrast in Lower 60 Percent of Gray Range

(4) Video Initialization

Displays the FLIR parameters for operator verification. On verification, the operator will be required to enter the boresight coordinate position of the FLIR video. Following this procedure, FLIR mensuration and/or navigation correction may be involved as required.

(5) TADIL-B Interface

The TADIL-B interface will be performed by the two basic functions of hardware and operator interface. The hardware interface performs the report formatting and provides the software interface to the digital TADIL-B interface unit. The operator interface provides the necessary displays to allow the user to generate, monitor, and control the flow of TADIL-B reports and to provide and maintain a history of all reports generated during the day.

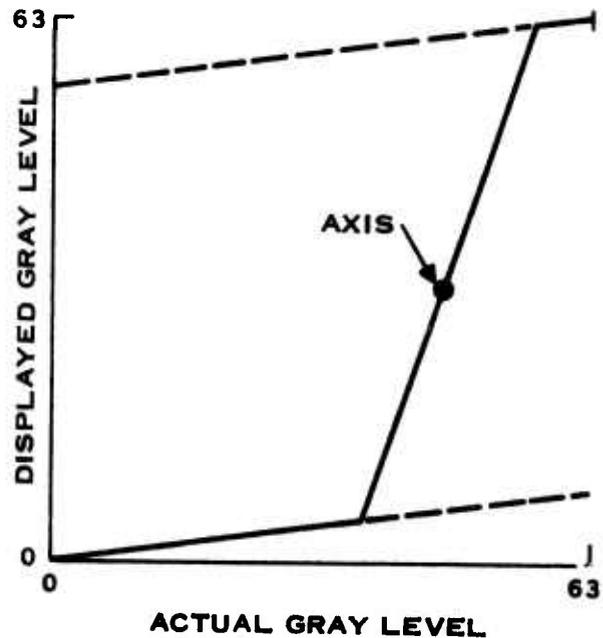

196362

Figure 7. Increased Contrast in Upper 40 Percent of Gray Range

REPORT GENERATION - TADIL-B TRANSMISSION

INSTRUCTIONS: -ENTER DATA, PRESS XMIT WHEN COMPLETE
-TO REVIEW PREVIOUS REPORTS, PRESS RESPOND

```
TARGET NUMBER      I PFFF
IDENTIFICATION     I XX
# OF TARGETS       I XX
TIME OF DISCOVERY  I PFFF
OPERATIONAL STATUS I X
PERISHABILITY      I X
RELATIONSHIP       I X
TGT LOC QUALITY    I X
LATITUDE           I 00MMSS.SI
LONGITUDE          I 000MMSS.SI
COMMENT            I XXXXXXXXXXXXX
.....
PERISHABILITY (TIME SENSITIVITY) - ENTER APPROPRIATE DIGIT
```

- 0 IF FLEETING
- 1 IF LESS THAN 30 MINUTES
- 2 IF LESS THAN 60 MINUTES
- 3 IF LONGER THAN 60 MINUTES

196363

Figure 8. Possible TADIL-B Report Format

(a) TADIL-B User Description

This function will generate a report in the TADIL-B format. Upon entering all necessary data, the report will be made available to the TADIL-B transmission software and the report will be entered into the historical report queue. Figures 8 and 9 represent two possible displays for generating a report and manipulating the past report queue. These figures do not represent final alternatives or report contents but are used to illustrate the functional flow and capabilities that can be designed into the report generation software.

Figure 8 is displayed when the TADIL-B function button is pressed. Some of the fields can have automatically entered data (for example, derived coordinates, target number, and time of discovery). The target number will be automatically incremented to provide the next sequential number. The target number used may be initialized or modified at any point in time to any valid four-digit number. The time of discovery entered automatically can be either the present system time (i.e., that point in time the report is created), or it can be the time as determined from the ADAS or FLIR parameters. The recommended entry is the ADAS or FLIR sensor time since the report should indicate the target position at a particular time. The field, however, could still be modified. All other fields will contain blanks and the appropriate data entered. To ensure accuracy, all fields will be validated and notification will be provided if any are in error. To assist in the accurate completion of the report, the HELP function may be activated. This function will provide a description of the field in question and the entries allowed in that field. These HELP definitions will be displayed on the lower six lines of the QR/RCU. Also available on these lower six lines would be the Split Screen function as previously discussed.

REPORT GENERATION - TADIL-B TRANSMISSION

PAGE XX OF NN

PAST QUEUE
 INSTRUCTIONS: -TO RETRANSMIT, PLACE 'R' IN COL 1 PRESS XMIT
 -TO PRINT ENTIRE QUEUE, PRESS RESPOND
 -TO DELETE ENTIRE QUEUE, ENTER 'D', X, PRESS ACK

TGT NUMB	IDTY	ONTY	TIME DISC	OPR STA	TIME SENS	FR/ MOD	LOC QUAL	LATITUDE DDMMSS.SI	LONGITUDE DDMMSS.SI	XMIT CPLT	COMMENT
. XXXX	XXXX	XXXX	XXXX	XXXX	XXXX	X	XXXX	XXXXXXXXXX	XXXXXXXXXX	HMMH	XXXXXXXXXXXXXX
. XXXX	XXXX	XXXX	XXXX	XXXX	XXXX	X	XXXX	XXXXXXXXXX	XXXXXXXXXX	HMMH	XXXXXXXXXXXXXX
. XXXX	XXXX	XXXX	XXXX	XXXX	XXXX	X	XXXX	XXXXXXXXXX	XXXXXXXXXX	HMMH	XXXXXXXXXXXXXX
. XXXX	XXXX	XXXX	XXXX	XXXX	XXXX	X	XXXX	XXXXXXXXXX	XXXXXXXXXX	HMMH	XXXXXXXXXXXXXX
. XXXX	XXXX	XXXX	XXXX	XXXX	XXXX	X	XXXX	XXXXXXXXXX	XXXXXXXXXX	HMMH	XXXXXXXXXXXXXX
. XXXX	XXXX	XXXX	XXXX	XXXX	XXXX	X	XXXX	XXXXXXXXXX	XXXXXXXXXX	HMMH	XXXXXXXXXXXXXX
. XXXX	XXXX	XXXX	XXXX	XXXX	XXXX	X	XXXX	XXXXXXXXXX	XXXXXXXXXX	HMMH	XXXXXXXXXXXXXX
. XXXX	XXXX	XXXX	XXXX	XXXX	XXXX	X	XXXX	XXXXXXXXXX	XXXXXXXXXX	HMMH	XXXXXXXXXXXXXX
. XXXX	XXXX	XXXX	XXXX	XXXX	XXXX	X	XXXX	XXXXXXXXXX	XXXXXXXXXX	HMMH	XXXXXXXXXXXXXX
. XXXX	XXXX	XXXX	XXXX	XXXX	XXXX	X	XXXX	XXXXXXXXXX	XXXXXXXXXX	HMMH	XXXXXXXXXXXXXX
. XXXX	XXXX	XXXX	XXXX	XXXX	XXXX	X	XXXX	XXXXXXXXXX	XXXXXXXXXX	HMMH	XXXXXXXXXXXXXX
. XXXX	XXXX	XXXX	XXXX	XXXX	XXXX	X	XXXX	XXXXXXXXXX	XXXXXXXXXX	HMMH	XXXXXXXXXXXXXX

CONT/END

196364

Figure 9. Possible TADIL-B Report History Queue

In general, the Split Screen function can display historical data, previous results from mensuration, or coordinate conversion.

When the report is complete and the targeting officer has verified its accuracy, the interpreter presses the XMIT button. The data will be verified for content and errors will be indicated. If there are no errors, the data will be packed into the required TADIL-B format and placed in the TADIL-B transmit queue. The system will then be returned to the idle mode and await further inputs. To generate another report, the operator need only press the TADIL-B function button again. Operationally, there is no limit or time constraints to the number or frequency of reports generated. All reports generated will be placed in the transmission queue.

Figure 9 illustrates a possible past TADIL-B queue format and capability. All reports generated will be entered in the queue and maintained there until the queue is deleted. To retransmit a particular message, place an "R" into the field preceding the report to be retransmitted. Pressing XMIT will cause Figure 8 to be displayed with all fields containing the previously entered data. The fields may be modified if desired and retransmission indicated. If this process occurs, the report will again be entered into the historical report queue. The XMIT COMPLETE field indicates the hour and minute that the report transmission was completed. This field, when coupled with the time of discovery field, will give an accurate assessment of segment throughput.

(b) TADIL-B Transmission

This function will operate in the background mode and will execute as required whenever a report is placed in the queue. The function need be activated only once during the system initialization procedure. When a report is placed in the transmit queue by the report generation function, this function will accept the input, format it properly, and transmit it through the TADIL-B modem interface to the command and control center. Upon completion, the transmit complete field in the historical report queue will be supplied with the current system time. The transmission function will continue to interrogate and process reports in the transmission output queue until the queue is empty.

(6) Loran Time Differentials

(a) Purpose

This subsection discusses a possible method of including a loran coordinate conversion function in the QSR-RRF. Discussions include possible extensions for the algorithm inclusion into the TIPI Imagery Interpretation Segment (IIS).

(b) Background

It has been a recognized requirement that exploitation facilities must contain the ability to process or accept loran time differences (TD) and use them effectively during tactical reconnaissance scenarios.

In June 1975, Lear Siegler, Inc., presented a paper at the Institute of Navigation in Washington, D.C., entitled "Recent Advances in Accurate Airborne Computation of Secondary Phase for Loran C Radio Navigation." This paper is a result of a modeling analysis performed by LSI while pursuing the loran navigation capability of the AN/ARN-101 Digital Modular Avionics System.

The technique involves the use of a polynomial fit of loran secondary phase to the following variables: distance, altitude, vertical atmospheric lapse factor, ground index of refraction, and effective wave impedance (Δ_E).

The latter quantity was introduced by Johler of the Institute of Telecommunications Sciences to account for the fact that the propagation paths are, in general, over irregular nonhomogeneous ground. A second set of polynomials map Δ_E , in terms of latitude and longitude for each station, over a given area which may be 10,000 square miles or larger. Some *a priori* data points are required. These may be measured empirically as time differences versus positions and/or calculated on a large digital computer using the wave integral equation and the known path topologies. Accurate calculation of the secondary phases using the above fitting polynomials in turn allows the subsequent loran-to-position coordinate conversion to be extremely accurate on an absolute basis. A demonstration of this technique in the Eglin Air Force Base vicinity using *a priori* ground and airborne measurements indicated a prediction capability standard deviation of 0.25 μ s on either of the time differences. Comparison of recent flight test TD airborne data, obtained from the AN/ARN-101 Digital Modular Avionics System, with the values predicted using the preceding model, verified this capability in practice.

(c) Concepts

For wide-area navigation, the general approach to coordinate conversion is some version of the well-known Sandano-Campbell method: given an assumed position, the expected times-of-arrival (TOAs) are calculated for each of the three or more loran stations; the TDs are computed and compared with the observed quantities and position corrections obtained. For determination of TDs given a position only, a single set of calculations need to be performed; if given the TDs, several iterations may be necessary to converge on a position estimate. The premise for an accurate calculation of the TOAs in the Sandano-Campbell methods is that the loran secondary phase be properly modeled. Calculation of the secondary phase must take into account distance and terrain effects, receiver and/or transmitter elevation effects, and temporal effects on the received signal.

From 1955 to the end of the 1960s, Johler of ITS did much theoretical analysis on the propagation of low frequency ground waves and then introduced the concept of an effective wave impedance, Δ_E , as a means to simplify the secondary phase calculations. With his assistance, LSI was able to develop a simplified algorithm which closely approximates the EGRWOO solution time (Johler's classical solution). The algorithm not only includes the calculation of the total received signal phase, but also determines the effective wave impedance utilizing a set of impedance maps onboard the aircraft.

(d) Execution

The propagation time estimates are determined by summing the primary and secondary phase effects. The primary phase effects are determined from the following parameters:

- Arc length between transmitter and receiver
- The speed of light in a vacuum
- The index of refraction of the propagation media.

The secondary phase effects are determined by evaluating a set of equations selected on the basis of altitude, distance, and effective wave impedance. The altitude and the distance from transmitter to receiver are easily determined quantities. However, the effective wave impedance at a given geodetic position is not as easily determined. Measured time difference data are used *a priori* to compute an effective wave impedance map for the region. A computer supporting a Fortran compiler, modeled this impedance map to yield a set of 15 coefficients for a given altitude and transmitter. For each transmitter, four sets of coefficients are developed to correspond with the altitudes of 0, 5,000, 10,000, and 15,000 feet and linear interpolation or extrapolation is performed as required. The appropriate set of coefficients is then used to determine an effective wave impedance for the position and altitude in question. This effective wave impedance is then used to determine the secondary phase contribution to the expected TOA.

The secondary phase contribution is selected on a basis of distance and wave impedance. Nine wave impedances were selected that spanned the real world impedances such that linear interpolation between them yielded acceptable results. Since the secondary phase contribution was also dependent on distance, each of the nine wave impedances selected was further refined to account for that distance. The result was 21 sets of coefficients that modeled the secondary phase. Hence, knowing that distance from transmitter to receiver, and knowing the effective

impedance as calculated from the impedance map, the secondary phase coefficients that bound the effective wave impedance are selected. The secondary phase polynomials are evaluated and interpolation performed to yield the contribution to the total received signal. This expected TOA, when correlated with the emission delays of the slave transmitters, provides the time differentials (TDs) required from the master to each of the slaves (TDA and TDB).

(e) Implementation in the QSR-RRF

The software system to be used in the QSR-RRF can be divided into the two general categories: support or utility routines and operator interface routines. The Lear-Siegler loran equations would be implemented as utility software routines capable of providing both loran-to-geographic and geographic-to-loran conversions. The system currently maintains a geographic to universal transverse mercator (UTM) conversion and its inverse. As previously described, the conversion process requires the polynomial coefficients describing the wave impedance at various altitudes for each of the loran transmitters. These coefficients would be coded in the software and would be capable of modification through operator interface. This operator interface would require the input of 180 nine-digit (plus exponent) numbers representing the polynomial coefficients. An additional 5 to 15 numbers would also be required to effectively model and predict the loran TDs in a given region. These coefficients are currently available from Lear-Siegler and represent the loran model for a 1- by 1.5-degree area around Eglin AFB.

A different set of coefficients would be required if the loran equations are to be used in any other area of the world. For application in the RRF, it is recommended that the Eglin AFB coefficients be predefined in the software and, to provide for possible deployment or demonstration in other areas of the world, allow these coefficients to be modified on-line. These on-line modifications would be implemented through a series of instructions presented on the CRT terminal of the RRF with appropriate directions for manual entry of the new coefficients via the keyboard interface.

To perform TD-to-GEO and GEO-to-TD conversions, an operator would press a function button that would provide the necessary instructions to perform a conversion. Upon selection of the conversion type, GEO-to-TD or TD-to-GEO, the operator would be presented a display containing blanks into which the appropriate data elements would be entered. Other parameters would also be presented at this time to allow modification if required. Some of the elements may be:

Index of refraction of the propagation media; if not modified, a nominal value of 1.000338 would be used

Effective wave impedance; use the wave impedance as generated by the polynomial evaluation or the effective wave impedance entered at this time

For TD-to-geographic conversion, a position estimate is required; an estimate will be displayed, and if a different estimate is desired, it should be entered at this time. The conversion result would be displayed to the operator and entered into a data file for later digital reference while composing a report.

Functions that would require modifications as a result of loran incorporation would include: mensuration, film initialization, priority point detection, frame search, and the device service routines that interface with the code matrix reader hardware.

B. FLIR EQUIPMENT ALTERNATIVES

During the functional flow analysis of system requirements, three basic component configurations were evaluated. Although each configuration evaluated satisfied the RRF concept requirements, the approaches vary in technical complexity with a corresponding variance in human interface requirements and software requirements. The configurations vary in the method used to display the video imagery. The alternatives are: an all-analog presentation of the video imagery; a mixture of analog and digital presentation; and an all-digital presentation. To satisfy the RRF requirements for real-time presentation of video imagery with a storage and replay capability, each configuration requires a video storage/playback unit. All RRF stations functionally appear equivalent with the differences being contained in the display system and its interface to the video replay disk.

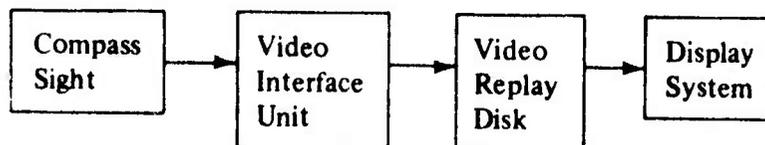

Vendor surveys were conducted to determine the existence and applicability of components capable to satisfy the RRF requirements (Table 2). The following sections describe those available components.

TABLE 2. COMPONENT AVAILABILITY FOR EACH ALTERNATIVE

	Alternative 1	Alternative 2	Alternative 3
Equipment alternatives			
PIC	2	1	0
CMR	2	1	1
IAC	0	0	1
FLIIC	0	1	1
Dual station light table	1	1	0
TLT	0	0	1
IAC	0	0	1
PTR	0	0	1
PTP	0	0	1
KW-7	0	0	1
TH-85	0	0	1
Communications alternatives			
DDL	Yes	Yes	Yes
TTY	No	No	Yes
Paper tape	No	No	Yes
Hard copy	Yes	Yes	Yes
Flat map storage	No	No	Yes
In-line film flow	No	No	Yes
AAD-5 analysis capability versus requirement	Highly overdesigned	Overdesigned	Adequate

1. Video Monitor

The video monitor is required in all configurations and at each station within the configurations. The two potential digital systems (to be described) use a CONRAC video monitor to display the FLIR imagery. The MARRES shelters of the TIPI complex also uses the CONRAC video monitor. The CONRAC monitor is a currently available, off-the-shelf device that is both versatile and cost effective.

The 23-inch cathode ray tube displays 30 full frames of data per second in either a 525- or 875-line format. The CONRAC monitor has an 800-line center resolution with geometry and linearity within a 2-percent deviation. The bandwidth is acceptable at 16 MHz, ± 2 dB. Power requirements of the monitor are 130 watts, 105 to 130 volts and can operate on frequencies of 50 to 400 Hz. The ruggedized monitor is an off-the-shelf item with a cost of about \$3,000.

The CONRAC monitor controls provide a high degree of flexibility. These controls are: brightness, contrast, raster expansion, X-Y raster movement, polarity reversal, and focusing. The CONRAC monitor is a recommended component in all configurations.

2. Video Replay Unit

Each station of the RRF requires a replay unit. Baseline requirements dictated that each unit have computer and manual control and a storage capability of 20 to 40 seconds of video history. Two replay units are available from AMPEX and one from Echo Science Corporation that meet these criteria.

a. *Ampex DR-10A Recorder*

The Ampex DR-10A is a portable video disk recorder capable of driving one or two recording disks. Using one disk at 1,800 rpm yields a storage capacity of 600 frames giving 20 seconds of history at 30 frames per second. The addition of a second disk would double the frame count and give a 40-second history retention capability.

Other characteristics of the Ampex DR-10A are:

Bandwidth: 4.2 MHz at 3 dB

Signal-to-noise: 37 dB, peak-to-peak video to rms noise, unweighted

Interchannel crosstalk: In record/reproduce mode, -40 dB

Power requirements:

105 to 125 Vac

8 amperes maximum

DC servo motor drive, 58-62 Hz

Size:

	Recorder	Auxiliary Blower Cabinet
Width (inches)	24	12
Depth (inches)	18.5	18.5

	Recorder	Auxiliary Blower Cabinet
Height (inches)	13	8.5
Weight (pounds)	80 to 113	25

Environment: Rack-mounted laboratory conditions.

The DR-10A will accept 525- or 875-line format and can be configured for operation by external control equipment. The DR-10A is an available unit with off-the-shelf delivery for about \$20,000.

This unit is not recommended due to its 4.2-MHz bandwidth limitation.

b. Ampex MD-600 Recorder

The Ampex MD-600 is a rack-mounted recorder capable of storing 600 frames on two disks in either 525- or 875-line format. It has computer compatible logic (TPL) for automated data processing. The MD-600 dual channel option will provide 10 seconds of history per channel.

Other characteristics of the Ampex MD-600 are:

Bandwidth: 6.3 MHz at 3 dB

Signal-to-noise: 32 dB, peak-to-peak video to rms noise

Interchannel crosstalk: -50 dB

Power requirements:

115 Vac

60 Hz single phase

20 amperes maximum

Size: Overall rack with all equipment

Height 77.25 inches

Width 25 inches

Depth 25 inches

Weight 500 pounds

Environment: STD laboratory conditions.

The MD-600 is available off the shelf for about \$40,000.

The bandwidth of this unit is acceptable; however, the large mechanical configuration is undesirable and consequently not recommended for use.

c. Echo Science Corporation, VDR-300 Recorder

The VDR-300 is a portable or rack-mounted recorder capable of storing 600 frames of video to yield 20 seconds of history. The unit can accept either 525- or 875-line video. The disk cassette is removable and can be replaced in 20 seconds. This feature is not required, but it offers operational and training advantages not available with other recorders.

Other attributes of the VDR-300 are:

Bandwidth: 6.5 MHz at 3 dB

Signal-to-noise: 44 dB at 4.25 MHz

Power requirements:

115 V, 50/60 Hz, or

230 V, 50/60 Hz, or

115 V, 400 Hz, and 28 Vdc

Interface: Computer compatible logic interface and a remote manual control panel

Size (rack-mounted configuration):

	Recorder	Auxiliary Blower Cabinet
Height (inches)	10.5	2
Width (inches)	19	19
Depth (inches)	21	8
Weight (pounds)	45 combined	

Record/playback rates: 1, 3, 6, 10, 15, 30 frames/second.

This recording unit has the best bandwidth of all available units and the best mechanical configuration. The VDR-300 is available for about \$25,000 and is considered a special build with a 6-month delivery schedule. The Echo Science VDR-300, as the most cost effective and flexible video tape recorder, is recommended for use in the QSR-RRF prototype evaluation.

3. Display Systems

a. *Computing Devices Company*

A Digiscan Simulation System was demonstrated by Computing Devices Company. This system used a PDP 11/45 computer to perform real-time enhancements and function memory interfaces six times per second.

The CDC digital display would contain the following components or capabilities if purchased for the QSR-RRF prototype:

1. Video A/D converter, 8 bits, 50 MHz
2. TV refresh buffer, 768 by 1,024 by 8
3. Histogram counters
4. Level slice table or function memory
5. TV video D/A converter
6. Cursor trackball
7. Real time hardware algorithm to take histogram counter outputs and generate equalization function.

Items 1, 2, and 4 are currently breadboard units. Item 6, the cursor, is not operational yet but is scheduled to be operational by the end of October. Item 7 is now currently accomplished in software in the PDP 11/45. The video monitor used for the demonstration (a CONRAC RQA14) is not included in the display system cost. Delivery time would be approximately 16 months at a cost of about \$250,000.

The CDC display system was the only vendor product found that could accept composite video as input and display the digital imagery in real time. The ability to perform this conversion in real time is a necessary requirement for a digital search console. Consequently, the only all-digital RRF configuration is developed through the use of the CDC display system.

b. COMTAL Corporation

The COMTAL 8000 series display system holds one image that is accessible through the computer interface at a 2 megabyte (pixel) data rate. A second image expansion capability is possible by adding a second disk refresh memory. The COMTAL image is 1,024 by 1,024 pixels where each pixel has the capability of 256 (8 bits) levels of gray. The system is capable of displaying 4, 6, or 8 bits of gray levels. A demonstration by the COMTAL Corporation showed a distinctive improvement in image resolution when displaying 6 bits of gray levels instead of 4 bits. The 6-bit gray image was then displayed using 8 bits of gray level. There was no noticeable improvement in picture characteristics over the 6-bit display.

A function memory is accessible through the computer interface. This function memory is a mapping characteristic that allows an input gray level to be mapped into a different gray level. The modification of this function memory allows histogram equalization as well as increased contrast over a given range of input gray levels.

The COMTAL display system also has a graphics overlay memory. This memory is a 1,024- X 1,024- X 3-bit array accessible through the computer interface. A potential use of the graphics overlay is for target annotation. The COMTAL display system has a trackball cursor that is accessible by the computer. The cursor would be used for target location, target annotation and other mensuration tasks. The video monitor (CONRAC) is included in the cost of the display system. The input information required by the COMTAL unit is digital. Therefore, the necessary control electronics must be designed to accept the composite video from the playback unit and convert it to a digital format. An A/D converter by Phoenix Data, Inc. is available to perform the basic A-D conversion.

(1) A/D Converter

The Phoenix Data, Inc. A/D converter model ADC 1106-60 performs 60 million 6-bit conversions per second. This conversion, coupled with the necessary additional control logic, would provide the required interface between the video replay disk and the COMTAL display system. Characteristics of the ADC 1106-60 converter are:

50-MHz analog bandwidth

Requires ± 5 -V, 24-watt, forced-air cooling

8- by 8- by 3-inch module.

The unit is available off the shelf for approximately \$6,000.

C. FLIR-ONLY CONFIGURATION ALTERNATIVES

The three basic equipment concepts of all-analog, analog-search/digital-interpretation, and all-digital are now discussed, indicating particular recommended components in various combinations. These combinations yield the following four equipment configurations:

- Analog search and interpretation
- Analog search, COMTAL interpretation
- Analog search, CDC interpretation
- CDC search and interpretation stations.

1. Analog Search and Interpretation

This alternative for the QSR-RRF is the most austere approach in that the number and cost of hardware components are minimized. Figure 10 illustrates the basic equipment interface and Figure 11 illustrates the mechanical configuration in the expandable Auxiliary Shelter. The video storage/playback unit is the Echo Science VDR-300 which is the recommended unit for this and all other configurations.

The Video Interface Unit (VIU) accepts as input the composite video as generated (or demultiplexed) by the Compass Sight receiving station. This video data is routed to each of the VDR-300s and is available for recording if the unit is in the record mode. The recorder mode can be specified by a control panel at each station or through the computer interface to the VDR-300s.

To perform off-boresight mensuration (target location, offset distance, azimuth, etc.) a cursor is required at the interpretation console. Implementation of the cursor interface is done through additional control logic in the VIU. This logic will monitor the cursor joystick electronics and then superimpose or mix a cursor reticle into the video imagery to be displayed on the CONRAC monitor. To use the cursor system, command logic will be defined and implemented within the VIU to allow the computer to interrogate or determine the current cursor position and to allow the computer to specify a cursor coordinate position.

2. Analog Search and COMTAL Interpretation

The search station consoles of this analog/digital equipment configuration are the same as in the previous all-analog configuration. The composite video inputs remain the same as well as the computer interfaces to direct the storage/playback units. The differences between the all-analog system and this configuration is the interpretation station. Figure 12 shows the analog/COMTAL equipment interfaces and Figure 13 illustrates the mechanical configuration of this alternative in the expandable auxiliary shelter.

To convert the composite video from the VDR-300 to a digital format required by the COMTAL display system, an analog-to-digital conversion must occur. The Phoenix Data Inc. 50-MHz A/D converter will be used in conjunction with necessary control logic to implement the required analog-to-digital conversion.

The trackball cursor, as well as the video monitor interface, is controlled by the COMTAL system and is actually included in the unit buy from COMTAL.

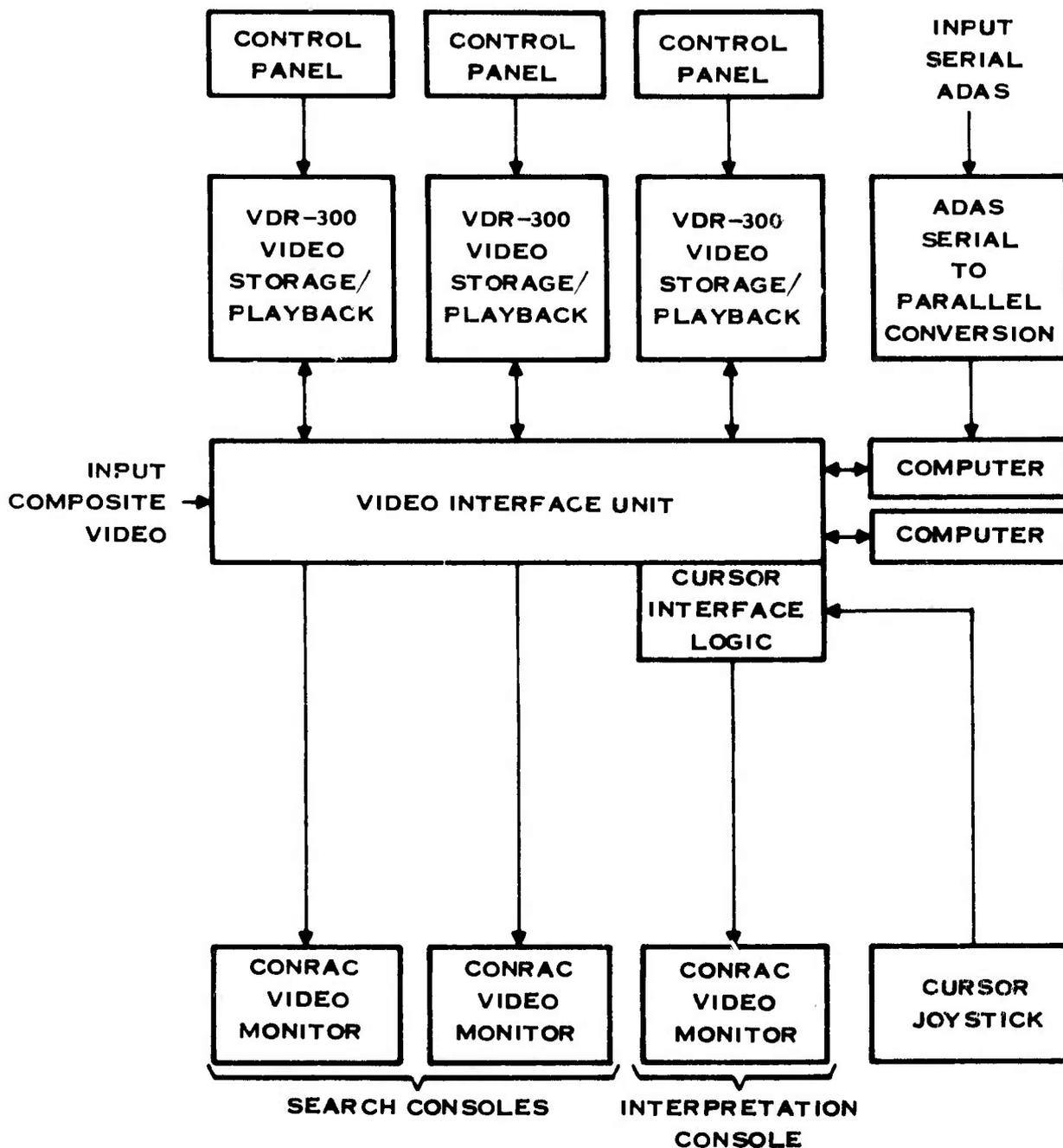

196365

Figure 10. FLIR-Only Analog Search and Interpretation Components

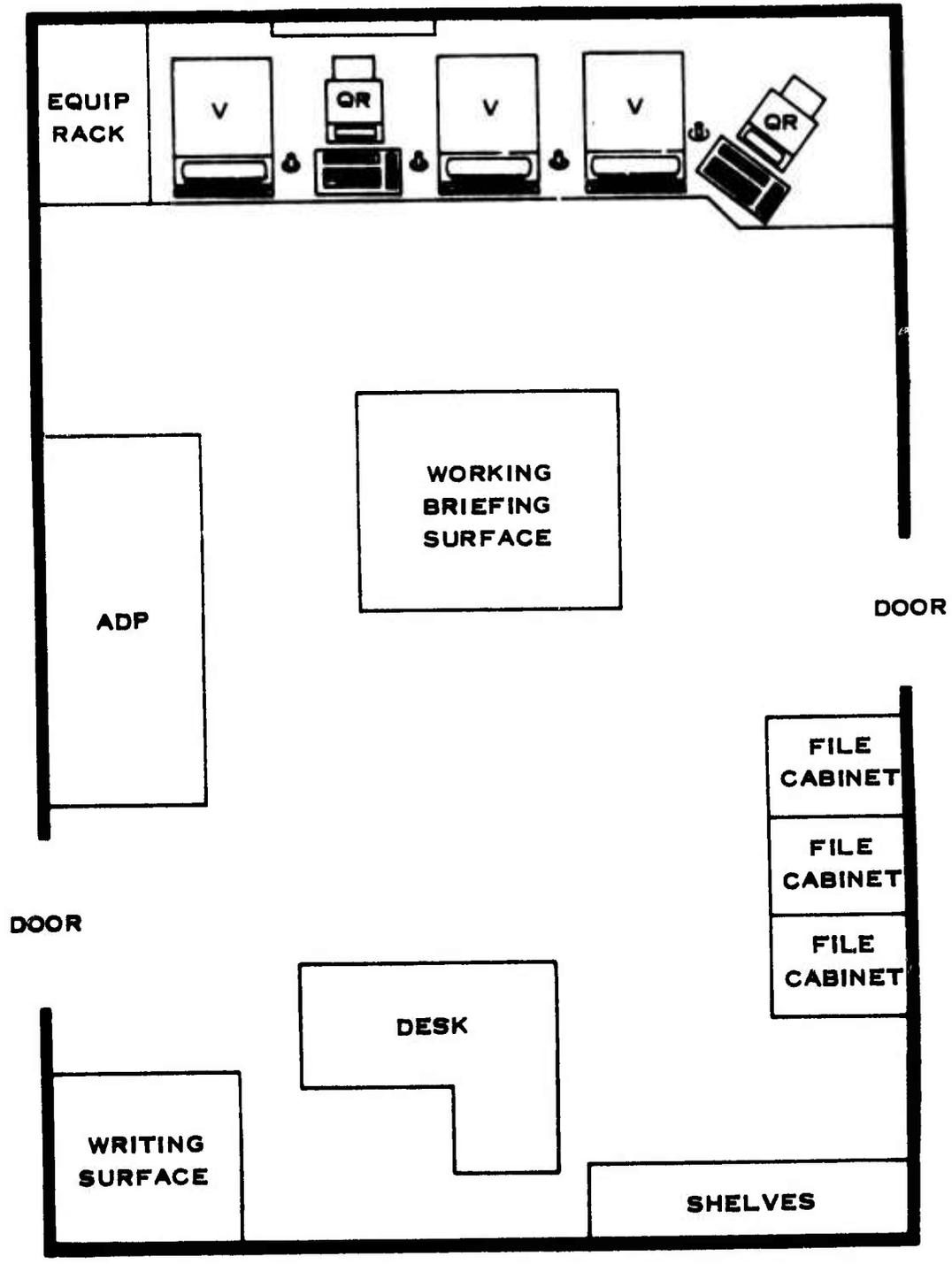

196366

Figure 11. FLIR-Only Analog Search and Interpretation Configuration

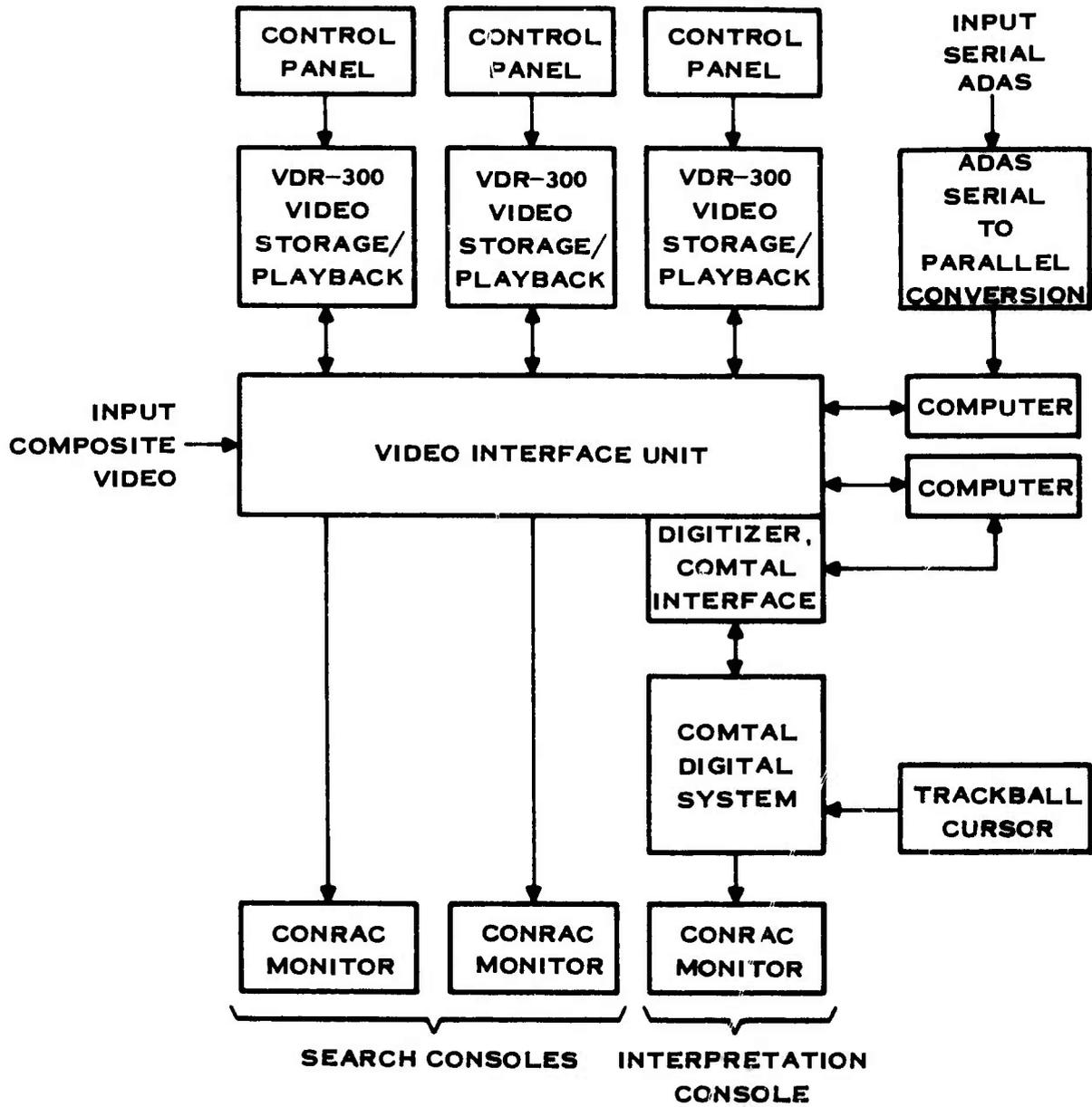

196367

Figure 12. FLIR-Only Analog Search and COMTAL Interpretation Components

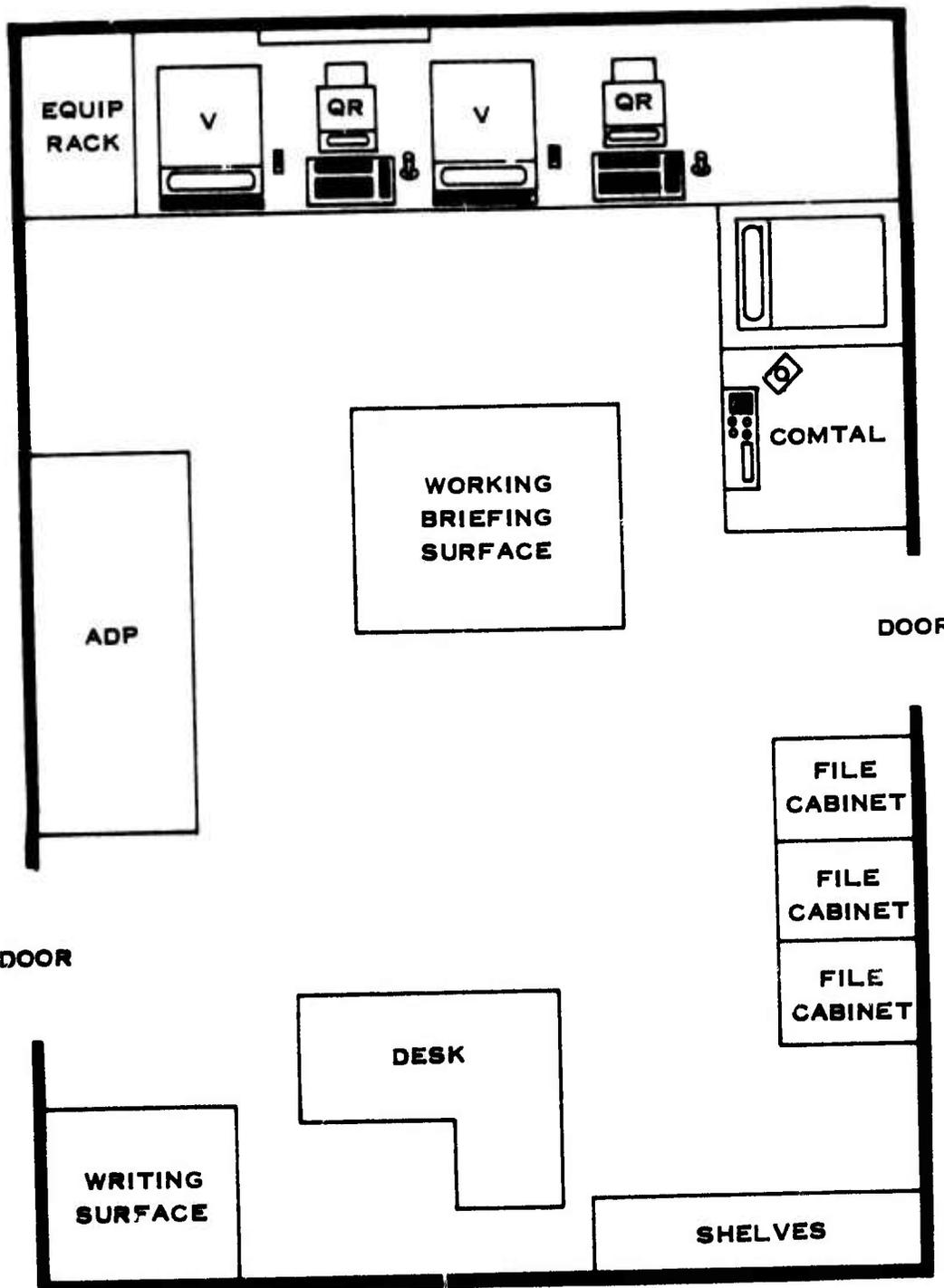

196368

Figure 13. FLIR-Only Analog Search and COMTAL Interpretation Configuration

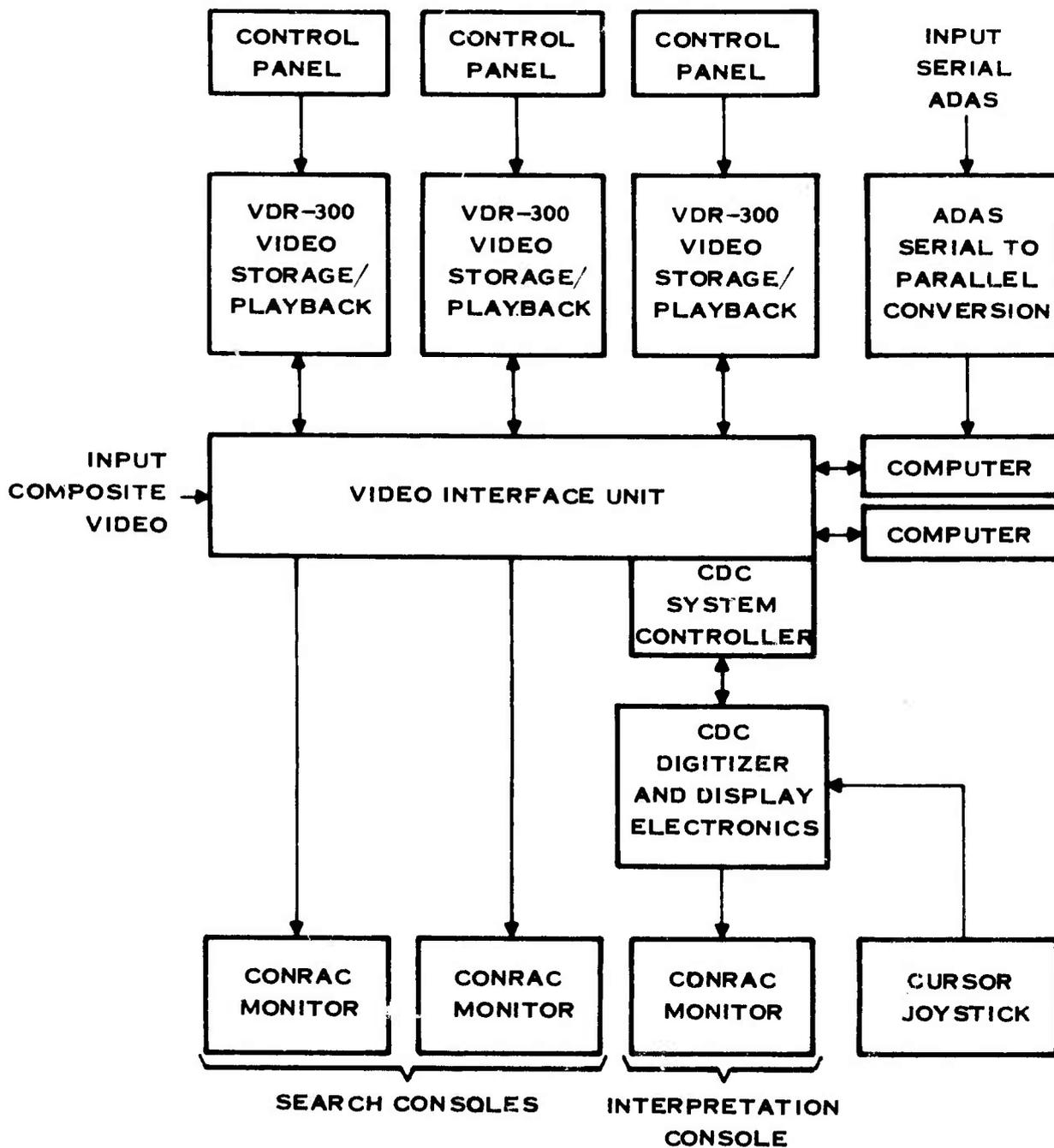

196369

Figure 14. FLIR-Only Analog Search and CDC Digital Interpretation Components

To perform the digital video enhancements as presented in the software applications section, an additional interface is required from the computer to the COMTAL system. This interface will be implemented in the same interface box that performs the A/D conversion. The standard VIU interface would be implemented using Interface E of the computer whereas the video enhancement interface capability would be implemented over an available parallel channel using the computer's autonomous transfer controller (ATC). The ATC is the recommended interface due to the quantity of data that need be transferred as well as the data rate requirements of that interface.

3. Analog Search and CDC Interpretation

In this configuration, the analog search stations are the same as in the two previous configurations. As with the COMTAL configuration, the difference lies in the equipment interface requirements and configurations to implement the interpretation console. Figure 14 illustrates the analog search stations with digital interpretation by Computing Devices Company (CDC). Figure 15 shows the mechanical configuration of this alternative. Since key components are still in the breadboard stage, the dimensions chosen for the equipment are 21 inches wide and 34 inches deep and may extend from floor to ceiling.

The CDC system controllers, as part of the VIU, would provide the necessary logic to interface with the CDC display system. Due to the cost, delivery schedule, and technical risk involved, this configuration and the following all-digital (CDC) configuration is not recommended for the RRF prototype evaluation.

4. CDC Digital Search and Interpretation

The CDC display system was the only system identified that could accept composite video and digitally display it in real time. The interpretation station remains the same as the previous configuration. The equipment interface changes to implement digital search stations are shown in Figure 16, and Figure 17 illustrates the mechanical configuration of this alternative.

As with the previous configuration, the cost and schedule impact make the all-digital system by CDC not a feasible alternative, and it is not recommended for the RRF prototype evaluation.

D. EQUIPMENT/CONFIGURATION ALTERNATIVES

Many concepts of QSR-RRF equipment and equipment layouts were considered and three configurations were thoroughly investigated. These alternatives were:

Alternative 1—Two PICs, compass site light table (CSLT), AAD-5 processor, three VDR-300 video recorders, two QR/RCUs, ADP equipment, and intermodule cables.

Alternative 2—One PIC, one FLIR interpretation console (FLIIC), CSLT, AAD-5 processor, three VDR-300 video recorders, two QR/RCUs, ADP equipment, and intermodule cables

Alternative 3—One interpretation console (IAC), one FLIIC, one target locating table (TLT), three VDR-300 video recorders, two QR/RCUs, ADP equipment, and intermodule cables.

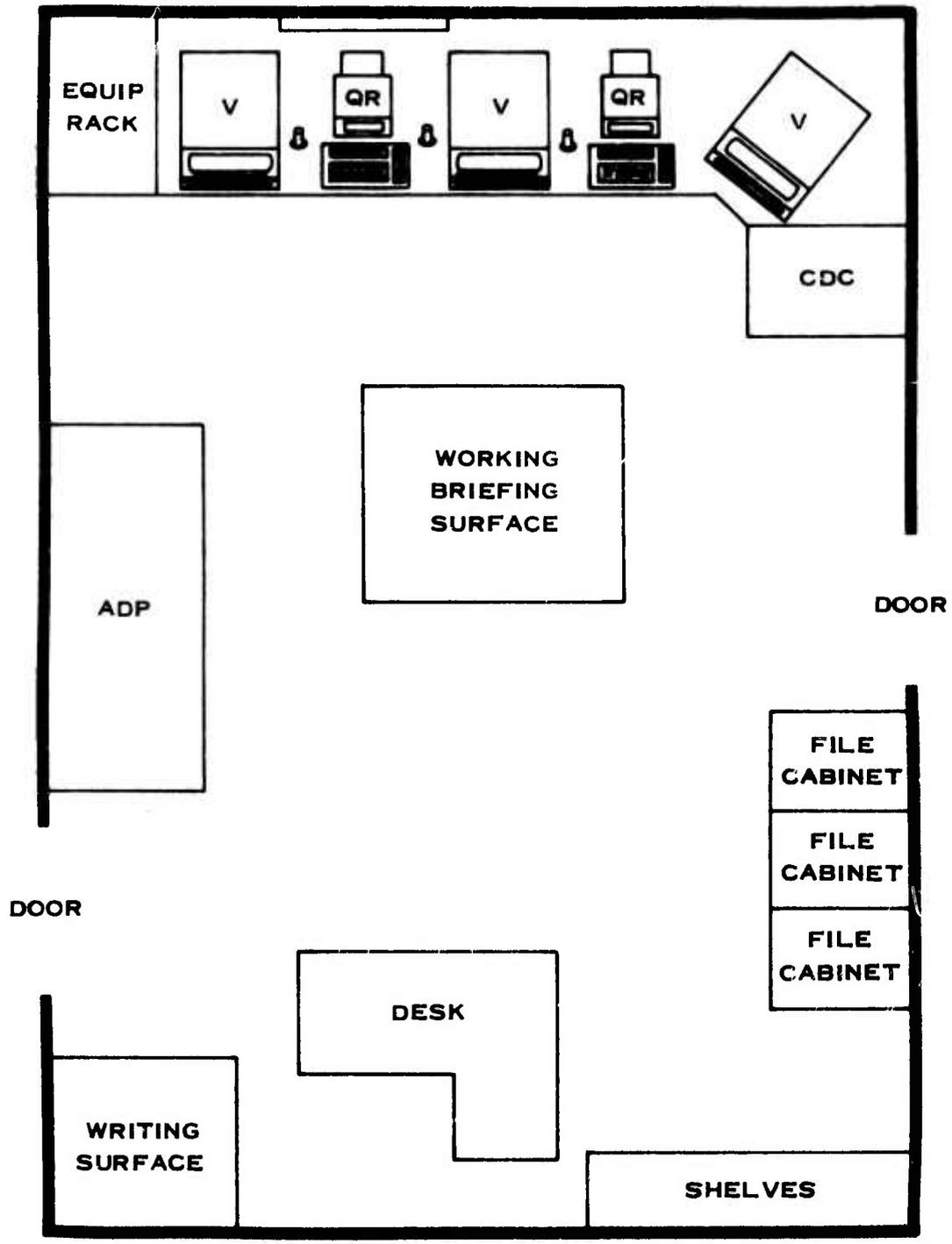

196370

Figure 15. FLIR-Only Analog Search and CDC Interpretation Configuration

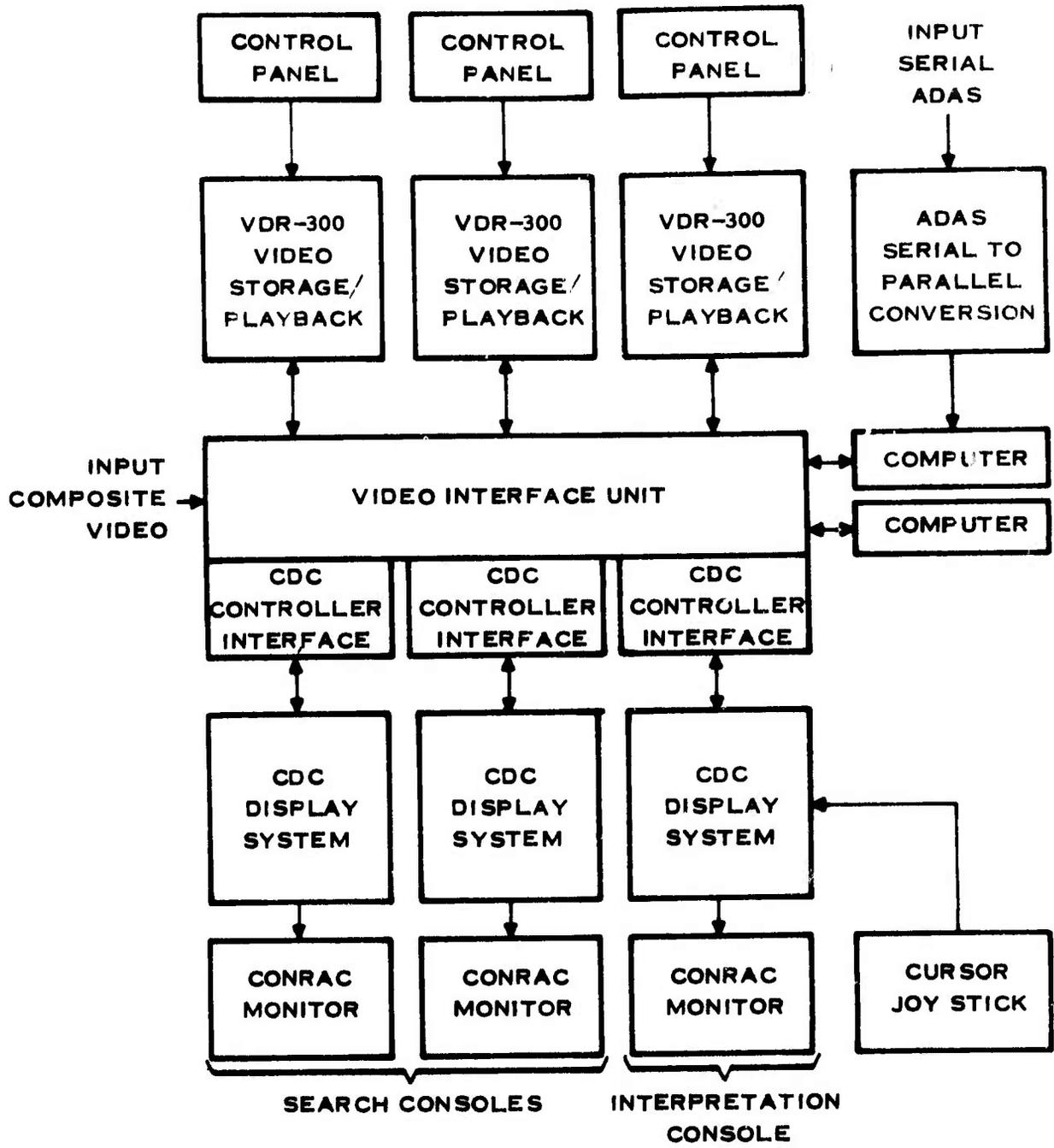

196371

Figure 16. FLIR-Only CDC Digital Search and Interpretation Components

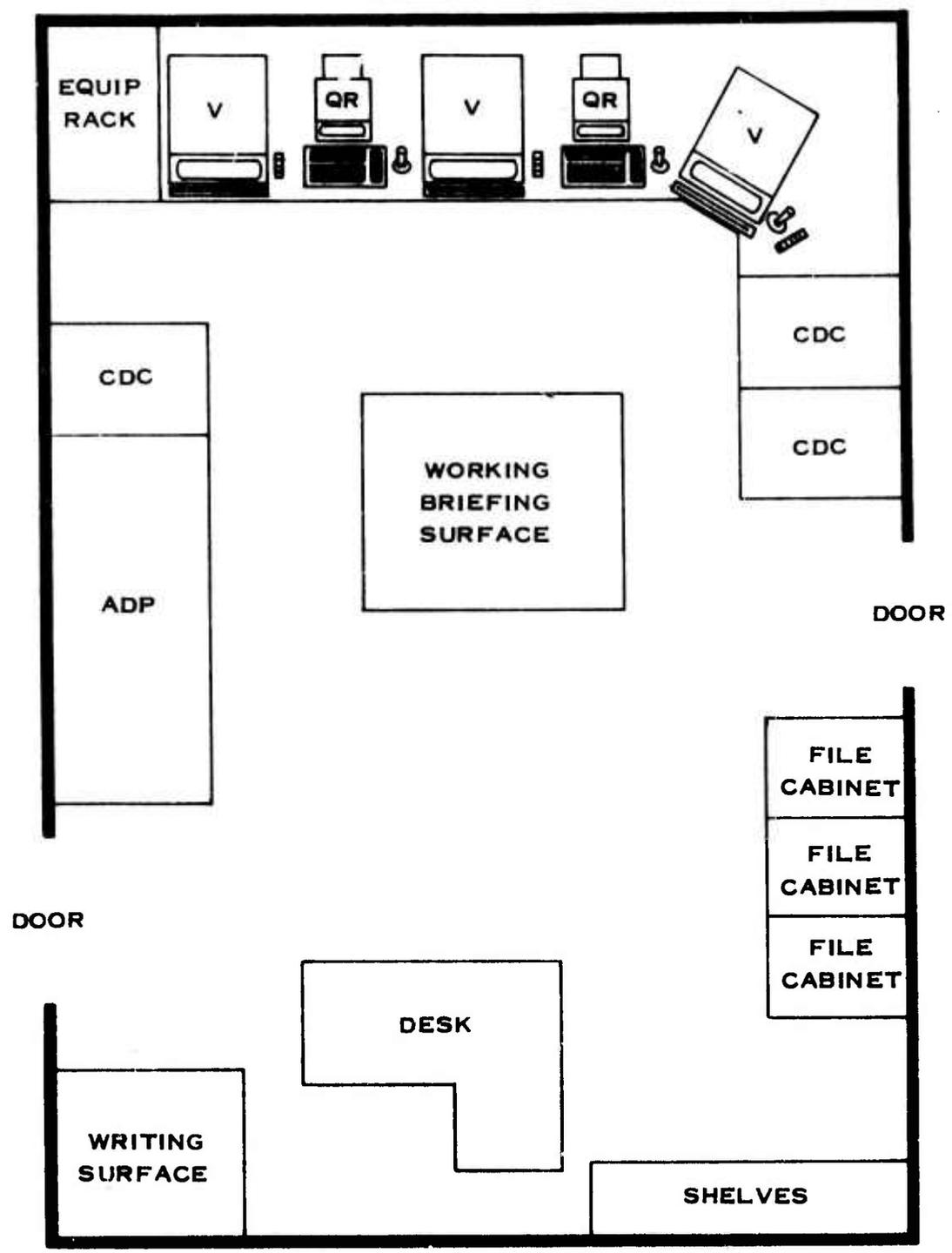

196372

Figure 17. FLIR-Only CDC Search and Interpretation Configuration

The analysis is based on the assumption that the QR-RRF would be housed within the physical limits of a shelter similar to the type used for the TIPI IIS interpretation shelter (IS). The only difference would be the addition of the necessary inserts to mount new equipment where it would be unsound design practice to use existing inserts because their location was inadequate to pick up the required loads. Consideration was given to using as much existing equipment as possible to minimize initial design and fabrication costs.

1. Alternative 1 (Two PICs)

Figure 18 shows the plan view of the configuration for Alternative 1 and Figure 19 shows the ADP equipment configured in the ADP rack. The two PICs, the ADP rack, and the roll film storage rack would be mounted in the QSR shelter in the similar location as they are in the IS. The space available for the QSR unique hardware is along the wall opposite the ADP rack. The inside edge of the emergency door is the left boundary limit, and the shelter end wall is the right boundary limit for installing the QSR AAD-5 equipment and presents 167 inches of allowable space. The AAD-5 processor, the two-station light table, and the front-to-rear dimension of the PIC would fit along this wall leaving 32 inches between the end of the light table and the front of the PIC where film loading would take place. The FLIR video monitor mounted at the right side of the light table would be somewhat hazardous to personnel loading film in the PIC film well. The PICs would be modified to remove the roll film projector (RFP) assembly and a FLIR video monitor would be mounted at this location on each PIC. The control panels for each of the three FLIR video monitors would be mounted directly below each monitor. This alternative requires that the film coming out of the AAD-5 processor be cut into segments and carried to the PICs for interpretation. The ADP equipment (Figure 19) includes the three VDR-300 video recorders (one associated with each FLIR monitor) and a video interface unit (VIU) in addition to the other standard ADP equipment required. The X-Y coordinate plotter is not required for the QSR-RRF, and its space would be available to house two of the VDR-300 recorders. The third recorder would require the space occupied previously by the paper tape punch (PTP). Since the PTP must be removed, the PTR would be removed also. To preserve a DDL capability, the KG-30 and modem would be required and would be located in the available space shown in Figure 19. The VIU would mount in the ADP rack above the CPU as shown in Figure 19. The KG-30 and the VIU would require the space occupied previously by the KW-7 send and receive units. Thus, no TTY communications link would be available. Accordingly, no TH-85 unit would be required. There would be no flat map storage available in this configuration because there is physically no space to incorporate it.

2. Alternative 2 (One PIC, One FLIIC)

Figure 20 shows the plan view of Alternative 2, and Figure 19 shows the ADP equipment configuration in the ADP rack. As shown in Figure 20, the PIC, ADP rack, and roll film storage rack would be located as they are in a standard TIPI IIS IS. The AAD-5 processor and light table would be located in the same space as described in Alternative 1. (Refer to discussion of Alternative 1 for details.) The PIC would be modified to install a FLIR video monitor and control panel where the RFP assembly is currently mounted. The configuration does require that AAD-5 film be cut into segments, then spliced to leaders and tails to be interpreted on the PIC. The PIC capabilities far exceed the requirements of a FLIR video monitoring and report generating station. For this reason, a FLIR interpretation console (FLIIC) was developed to provide only those capabilities to satisfy functional requirements for FLIR video analysis. The FLIIC would be installed in the area currently occupied by a PIC. The FLIIC would be a welded framework that housed two FLIR video monitors with their control panels, one QR/RCU and a

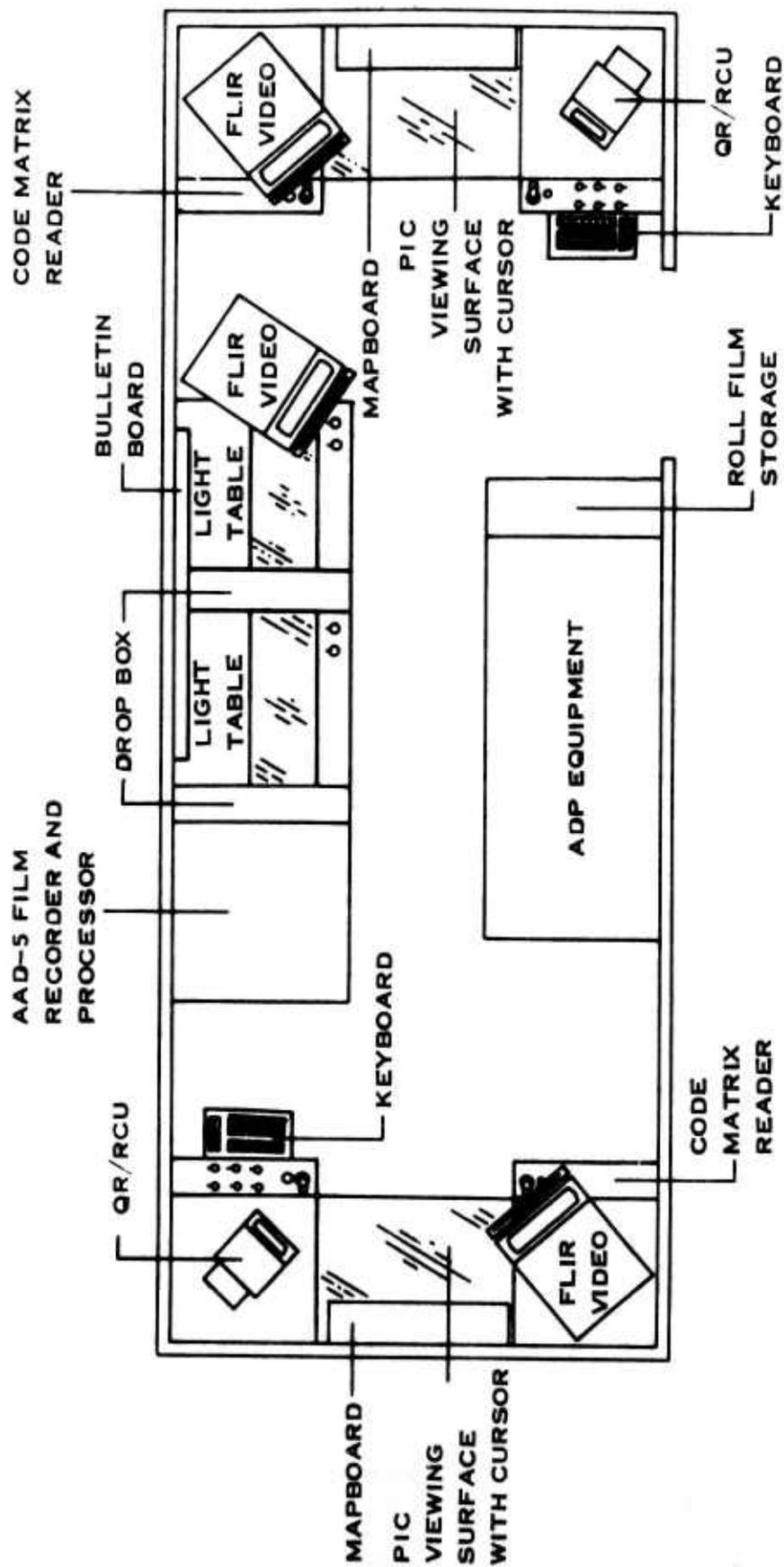
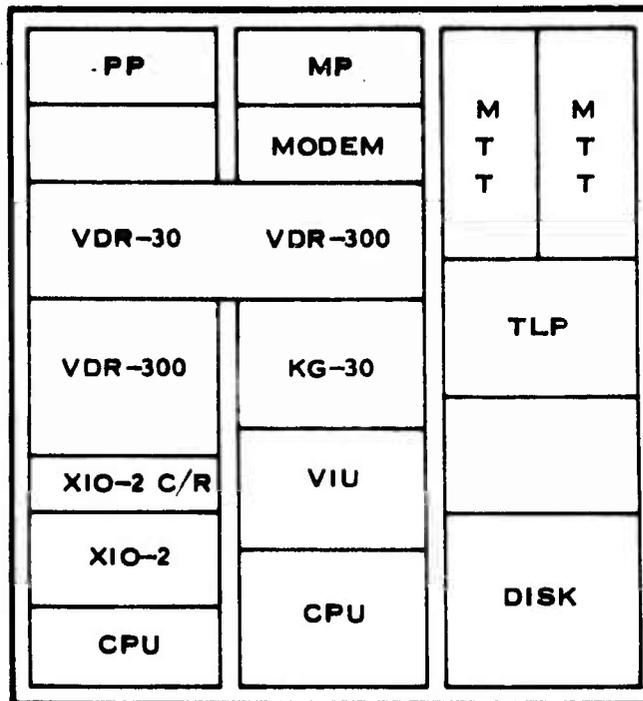

Figure 18. Configuration of Alternative 1

196373



196374

Figure 19. ADP Equipment Configuration of Alternatives 1 and 2

mapboard with a cursor system. The console configuration would be designed so that either FLIR operator could view the video, the QR/RCU monitor, the mapboard, and have access to the QR/RCU keyboard with minimum body and eye movement. Also, one operator would not physically interfere with the other operator's FLIR video viewing. This is accomplished by designing the viewing angles of the FLIR monitors inward to minimize the side viewing angle of each CRT. When the operators are scanning the video, they may sit directly in front of the monitor without interference with each other. For the advanced design, the FLIIC would be a free-standing console with the mapboard attached to the wall.

The FLIIC would have several advantages over the PIC. The frame would be less complex, lighter, and less costly; no CMR is involved with the FLIIC, which would eliminate CMR procurement and maintenance costs of one CMR; and there is no risk of PIC damage during transit or shelter exchange. The FLIR monitor that would be mounted to the right of the light table in Alternative 1 would be moved to the FLIIC. This alternative not only localizes the FLIIC interpretation activities, but eliminates that video monitor as a personnel safety hazard when a PIC operator is loading film into the PIC.

The ADP equipment for Alternative 2 is identical to that in Alternative 1 (Figure 19) because the FLIIC would occupy the same space as the PIC it replaced, and no more room would be available in this configuration than would be available in Alternative 1. Thus, the communications capabilities would be identical to Alternative 1 and would consist only of DDL (TADIL-B) and hard copy (thermal line printer).

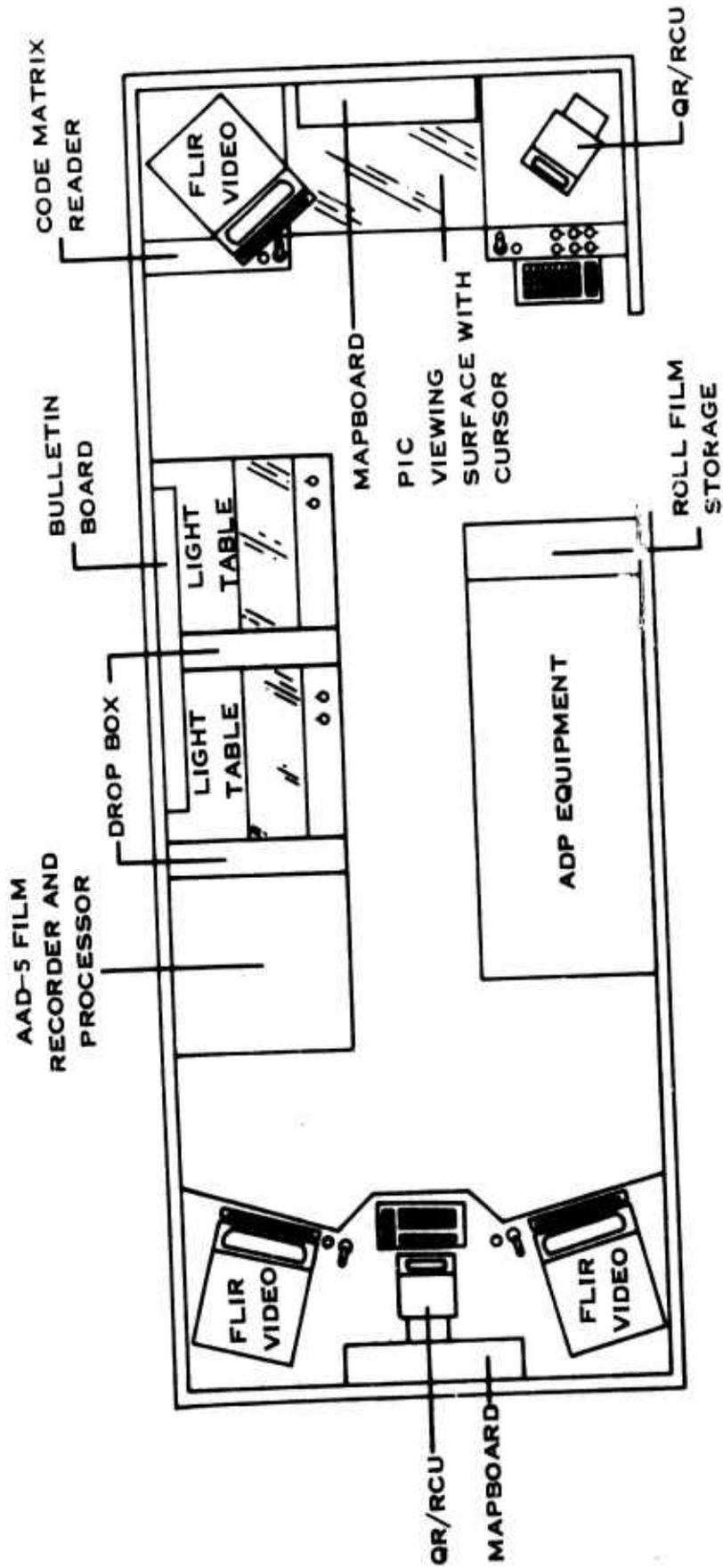

Figure 20. Configuration of Alternative 2

196375

3. Alternative 3 (One FLIIC, One IAC)

Figure 21 shows the plan view of the shelter layout for Alternative 3, and Figure 22 shows the ADP equipment configured for Alternative 3.

The ADP rack would remain in the same location as in a TIPI IIS IS. The AAD-5 processor and the FLIIC would be located as in Alternative 2, the FLIIC would house the two FLIR video monitors with their control panels and the QR/RCU, and the mapboard with cursor system would be mounted to the wall. Each video monitor would have an associated cursor control capability.

Three new equipments are proposed for this configuration; they are the Target Locating Table (TLT), the Interpretation Analysis Console (IAC), and the Auxiliary Automatic Data Processing rack (AADP rack). The TLT replaces the two-station light table in Alternatives 1 and 2. The TLT is smaller because it has only one detection station instead of two. One station is adequate for this configuration.

A fold-out writing surface would be provided for taking notes and a bulletin board would be provided behind the TLT for maps and other reference materials. The controls will be limited to light intensity and film direction/speed controls, which will increase reliability and decrease maintenance and cost. The TLT film drives will be controlled to avoid overdriving the film on the TLT to prevent an induced tension force on the film in the AAD-5 film processor.

The most significant improvement of Alternative 3 is the proposed use of the IAC. This console would satisfy the film interpretation requirements of the QSR-RRF by employing only those capabilities of the PIC which would be required and, most significant, provide in-line film flow from AAD-5 processor through target detection on the TLT to film interpretation on the IAC. A code matrix reader (CMR) would be on the left of the IAC. The IAC will contain a light table with cursor system and controls, a QR/RCU, a FLIR video monitor and control panel, a film take-up assembly with direction and speed controls, and a mapboard with cursor system and controls. The mapboard, QR/RCU and FLIR video monitors would be mounted to the wall behind the IAC and all other components would be supported by the IAC welded frame assembly. The IAC film drive would be independent of the TLT film drive and would be interlocked to prevent either drive system from influencing the other. The IAC would be lighter and more compact than a PIC, have fewer controls and could be produced at a lower cost. The in-line film flow eliminates the need for cutting film and distributing it to the PIC. The viewing angles of the QR/RCU monitor and FLIR video monitor would be designed so that the interpreter would be at the focal point of all components when an operator is seated at the light table.

The ADP equipment in Alternative 3 may be expanded by using an additional 19-inch equipment rack in the corner of the RRF. This space would be made available by eliminating the second PIC. Figure 22 shows both the ADP rack and the AADP rack. Three significant features may be added to the RRF by the addition of this rack space. The AADP rack could house the three VDR-300 video recorders. The KW-7 send and receive units, and the video interface unit (VIU). By moving the three VDR-300s to the AADP, a flat map storage area could be incorporated into the ADP rack. This is the only alternative which would have space available for this type of map storage. By placing the TH-85 in the ADP rack and the KW-7s in the AADP rack, a TTY communications capability would be possible. Additionally, the PTP could be placed back in the ADP rack as well as the PTR, thus increasing the system I/O flexibility.

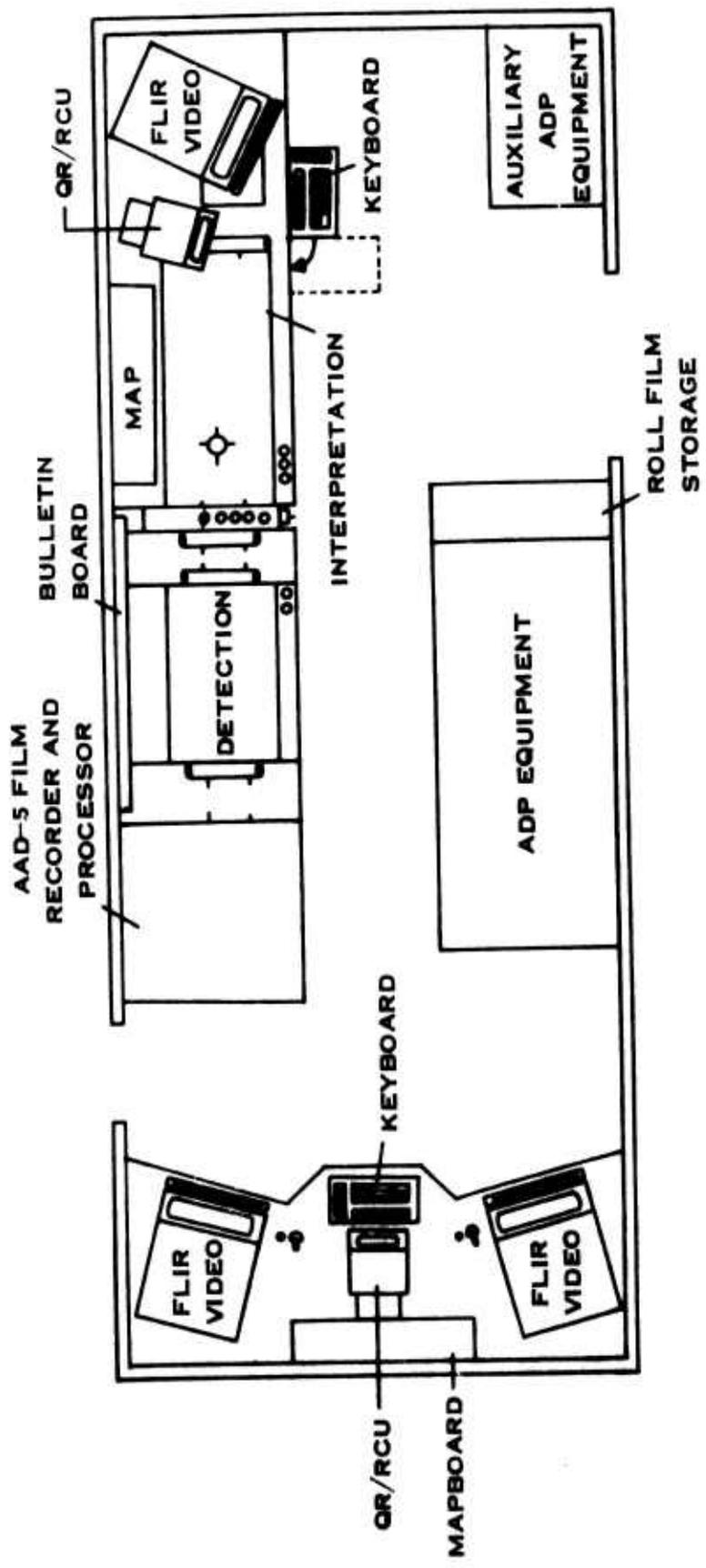
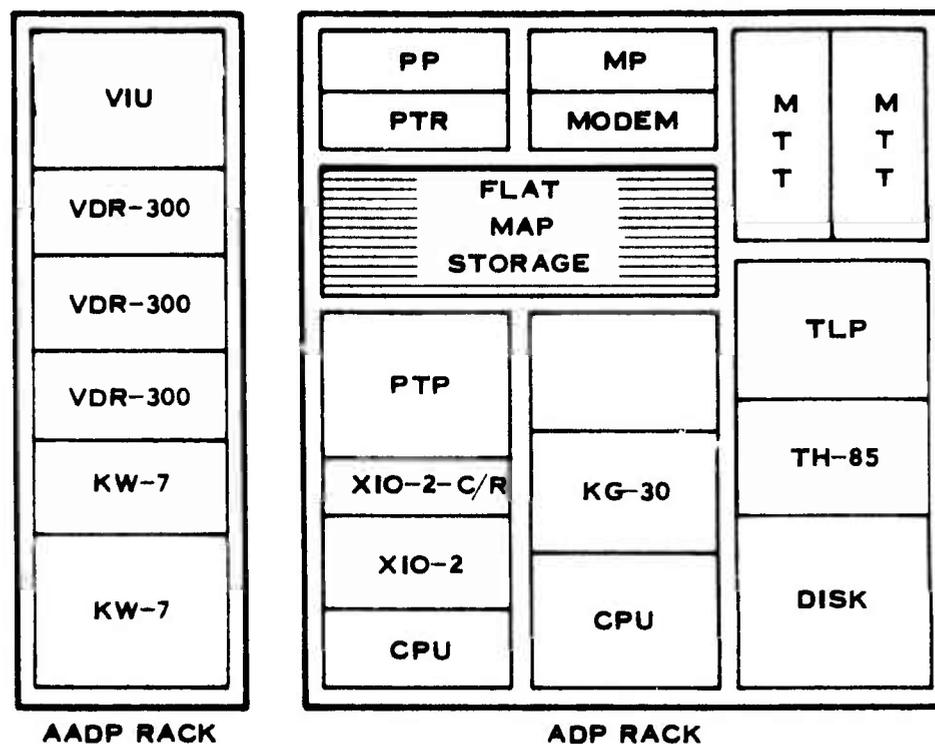

Figure 21. Configuration of Alternative 3

196376



196377

Figure 22. ADP Equipment Configuration of Alternative 3

4. Shelter Configuration Analysis

A configuration analysis was performed in which the feasibility of installing QSR RRF equipment was evaluated for an interpretation shelter (IS), rigidized auxiliary shelter (RAS), a commercial trailer van (CTV), and an expandable auxiliary shelter (AS).

The recommendation of the expandable AS as the proposed configuration is based on the evaluation of type of equipment, physical space required for the equipment selected, cost of conversion to the QSR RRF configuration, mobility or transportability of the newly configured RRF shelter, and the operational analysis.

The alternative configurations addressed the possible use of the following existing equipments: photo interpretation console (PIC), compass site light table (CSLT), and the required equipments which include the VDR-300 video recorder, AAD-5, FLIR and IIS ADP equipment. Also, three new variations of equipments were investigated; these were: a FLIR interpretation console (FLIIC), a targeting light table (TLT), and an imagery analysis console (IAC). Refer to Figures 18, 20, and 21 while reading the following subsections.

a. Interpretation Shelter (IS) to the RRF Alternative

If the IS (8 by 20 feet) is used as the RRF, then only one combination of the hardware would be physically feasible to maintain the in-line film flow objective discussed in the operational analysis. Note that the FLIIC is shelter independent and will not enter into the

alternative choices. Only the IAC and the TLT would fit in line with the ADD-5 processor in the wall space available in an IS. Any other combination of PIC and CSLT, PIC and TLT, or IAC and CSLT exceeds available line wall space. This is also true if the two-station detection/distribution console is used instead of the compass sight light table. This limitation of space is based on the belief that any production unit will be configured in a standard IIS rigid shelter modified only to allow for new mounting inserts.

The results of the operational analysis indicate that the equipments that best satisfy the requirements of the QSR-RRF are the FLIC, the TLT, and the previously listed required hardware.

While this configuration is dimensionally feasible, no workspace or observation space would be available during demonstrations and exercises, and no configuration flexibility would be available for evaluation.

Conversion of an IS to a QSR-RRF involves the very undesirable task of removing the PICs from the IS. This would require extensive use of a rented crane to move the IS to a free work area, unbolting the PICs, and placing them in a truck to be moved into storage. The reverse procedure would be required upon completion of the QSR-RRF evaluation. These procedures, without production AGE, would not only be costly but would expose the PICs to possible damage during handling.

The transportation of the RRF in an IS could be accomplished by commercial air suspension trailer with loading and offloading performed by a crane.

b. *Rigidized Auxiliary Shelter (RAS) to RRF Alternative*

The second shelter alternative would be a rigidized AS (RAS). This would involve removing the expandable floor, ceiling, and two end panels of the AS and attaching the expandable side wall directly to the rigid portion of the AS at the open side interface. As previously indicated, in-line film flow is the desired mode of operation which requires the AAD-5 processor, TLT, and IAC to be along a process line. This is not possible in the rigidized AS because this layout blocks the auxiliary exit; the door is nearer the center of the wall in the AS expandable wall than the IS wall, and this creates an unacceptable safety hazard. The conversion of the AS to the RAS to the QSR-RRF does require the removal of the panels as indicated. Additionally, all other AS equipment except the ADP equipment must be removed. This configuration offers no space for observation of the equipment and operators during evaluation. Conversion to the RRF would involve removal of all AS hardware except the ADP equipment plus the removal of the wall panels described above.

Transporting the RRF in the RAS could be accomplished by using a commercial air suspension trailing with loading and off-loading done by crane.

c. *Use of a Commercial Trailer Van (CTV) for RRF*

Consideration was given to installing the QSR-RRF in a trailer van. A van with basically the same internal dimensions as a rigid shelter could be acquired. To simulate a rigid shelter, doors would have to be installed in the van, or at least one serviceable door for safety.

Conversion of the trailer to the RRF would require significant modification to be able to attach all of the equipment racks, air conditioning and cabling ducts, and doors required. Special doubler plates and all inserts would have to be put into the van to spread the transportation shock and vibration loads over a large enough area of the van wall to safely transport the RRF. The van would have to be purchased because of the extensive modifications required. Jacks or shoring would have to be deployed with the trailer van to firmly set the shelter in place and prevent van motion caused by personnel movement that might affect the levels of processing chemicals in the AAD-5 processor or film exploitation under modification.

This approach also provides no observation space for personnel during evaluation.

Transportation of the QSR-RRF could be accomplished by wiring a commercial tractor to pull the trailer van. The shoring or jacks would have to be shipped separately because shipping containers for the videos will take up the floor space in the van during transport.

d. Auxillary Shelter (AS) to RRF Alternative

Use of the AS as the QSR-RRF offers the greatest flexibility at the lowest risk of any alternatives considered. When the AS is expanded, the AAD-5 processor, TLT, and the IAC may be placed in line in the center of the shelter. With the equipment in place, the rigid shelter door location can be simulated, and there is adequate space behind the simulated wall for evaluation observers to work. This configuration is flexible in that the in-line configuration may be positioned closer to or farther from the ADP side of the shelter to allow observers and operators the most convenient monitoring configuration or most nearly actual operating configuration depending on placement of the simulated wall.

Conversion of the AS to the RRF configuration is less complicated than any other approach considered. Risk is minimal with the AS approach because no major critical items (e.g., PIC) are removed, nor is any major wall panel removed (as in the rigidized AS approach). Only the map storage cabinet need be unbolted; all other items, file cabinets, shelves, etc., are standalone and may be removed by carrying them out.

For transportation the RRF shelter may be moved by a commercial air ride trailer van with loading and off load accomplished by crane. The same equipment is required to transport any of the shelter configurations considered. The RRF equipment will be designed so that it is transportable within the AS and will not require special carrier for it.

SECTION IV

RECOMMENDED CONFIGURATION

The recommended configuration, which is Alternative 3, is a result of considering available militarized and commercial equipment configured to satisfy the RRF operational requirements. The selected configuration optimally satisfies configuration, equipment, and human resource requirements. All elements of the system, whether equipment or operator tasks, yield a system that minimizes human interactive requirements while maximizing capabilities and flexibilities.

While this recommended configuration does not explicitly represent a production field system, it does allow the concepts of this system to be tested and evaluated. The results of fabrication and the operational test and evaluation should yield sufficient analyses to determine a field operational configuration suited to the unique and particular requirements of the QSR-RRF.

A. RRF EQUIPMENT

The RRF prototype is an integrated collection of militarized and commercial components. Table 3 provides a list of equipment and the source of those components. Most of the components are to be provided by the Government from the TIPI II segment complex located at Dallas, Texas. The monitors and video recorders required to provide a FLIR capability are also GFE from RADC, from the contractors CONRAC Corporation, and the Echo Sciences Corporation. To integrate these elements into the RRF additional components are defined and must be designed, fabricated, and installed in the system. These components are the video interface unit (VIU), the FLIR data serial-to-parallel conversion unit, and the TADIL-B interface unit.

Included in the cost analysis are the required shelter modifications, equipment racks, cables, and control panels necessary to configure the components to provide the FLIR and AAD-5 interpretation capabilities.

Figure 23 represents the hardware interfaces of the RRF components. The figure indicates the type of data transfer (parallel or discrete) to be used in the fabrication. Detail design and command formats will not be developed until fabrication efforts begin. However, the analysis has been performed to ensure that each operational capability can be accomplished through the defined hardware configuration.

B. SHELTER AND CONFIGURATION

The shelter recommended for use during the QSR-RRF IOT&E is the expandable auxiliary shelter. The rationale for this selection is to provide an accurate simulation of an 8- by 20-foot shelter and to provide, following reconfiguration, sufficient personnel area to accommodate demonstrations and briefings. This shelter configuration also yields a minimal configuration cost as well as the least risk in deployment packaging for transportation to Eglin AFB. Figures 24 and 25 represent the expanded 16- by 20-foot auxiliary shelter and the approximate equipment positions. In Figure 24, the equipment is configured to evaluate work space requirements available in an 8- by 20-foot rigid shelter. As previously mentioned, there would be little or no room available for observers and demonstrations. Figure 25 represents the approximate position of the equipment in the briefing or demonstration mode. This configuration will allow sufficient area for observers to view the FLIIC, the AAD-5 interpretation sequence as well as ADP equipment rack.

TABLE 3. PROPERTY LIST REQUIREMENTS FOR THE QSR-RRF

	Quantity Required	Source	Spares Required	Spares Required
QR/RCU Assembly	2	II/GFE	1	1*
CP-1093 (CPU)	2	II/GFE	1	1*
XIO-2 digital switch	1	II/GFE	0	0
Code matrix reader	1	II/GFE	1	1*
Photo interpretation console	1	II/GFE	1	1*
Map boards	2	II/GFE	0	0
Magnetic tape units	2	II/GFE	0	0
Magnetic disk	1	II/GFE	1	1*
Paper tape RDR/PUN	1 set	II/GFE	0	0
Thermal line printer	1	II/GFE	0	0
VDR-300	3	Echo Science/GFE	0	0
VDR-300 disk cassettes	10	Echo Science/GFE	0	0
RQB17/C video monitor	3	Conrac/GFE	1	0
Encryption gear (full duplex)	2 sets	GFE	1	0
Video interface unit	1	Texas Instruments	0	0
FLIR serial to parallel conversion	1	Texas Instruments	0	0
TADIL-B interface	1	Texas Instruments	0	0
Shelter in cables	1	II/GFE	0	0
Environmental control system	1	II/GFE	0	0
TADIL-B modem	2	GFE	1	0
AAD-5 recorder/processor	1	GFE	0	0

*These components are available from the II system currently located at Dallas, Texas.

Figure 26 represents an isometric projection of the AAD-5 detection and interpretation stations. This artist's conception shows the take-up boxes, film drive rollers, relative sizes of components and surfaces, and approximate positions of the various components. In a similar manner, Figure 27 portrays the FLIR interpretation console (FLIIC).

Figure 28 shows the fabrication schedule based on receipt of contract. Receipt of GFE monitors and recorders are indicated as a necessary milestone.

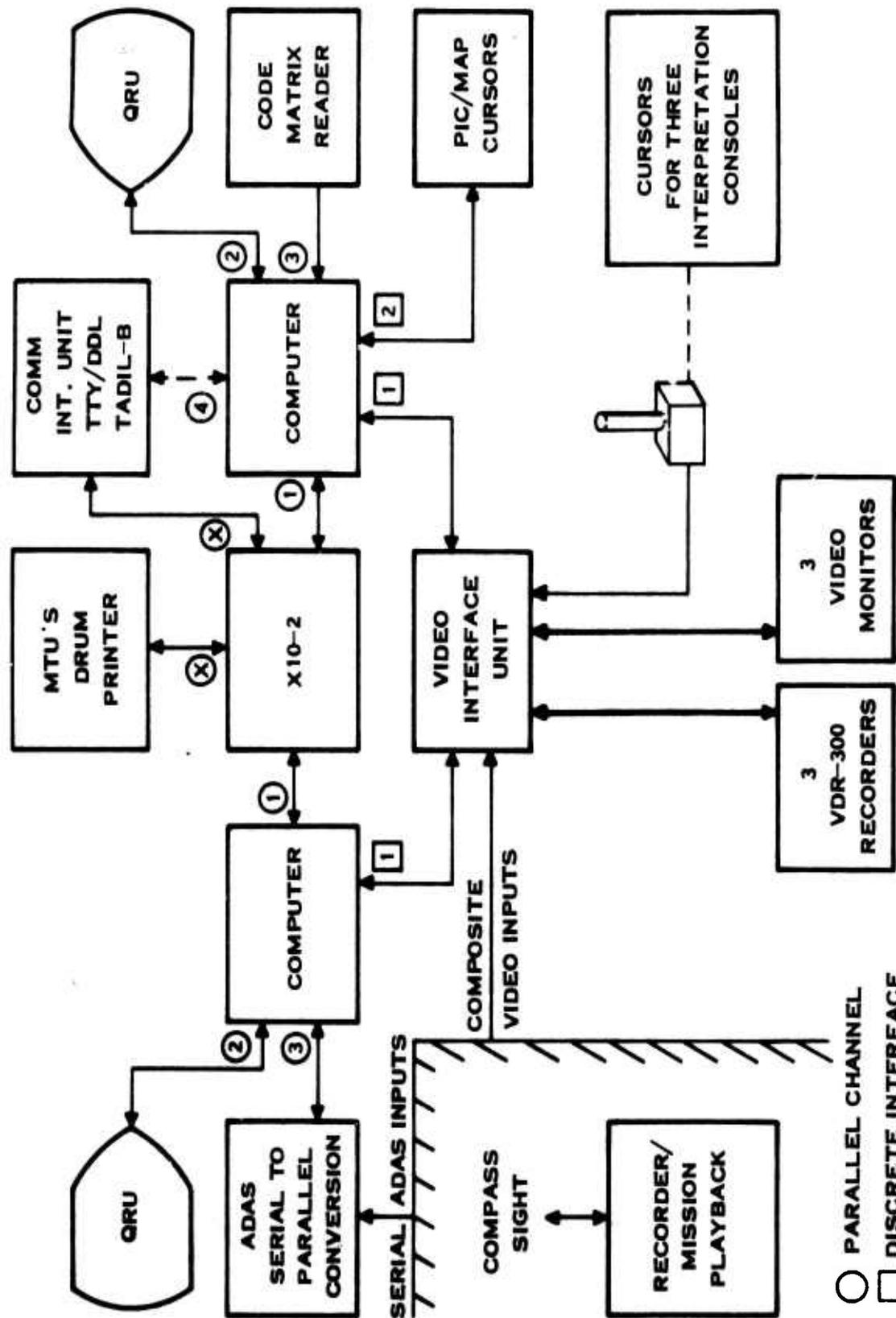

Figure 23. Hardware Configuration of the RRF

196378

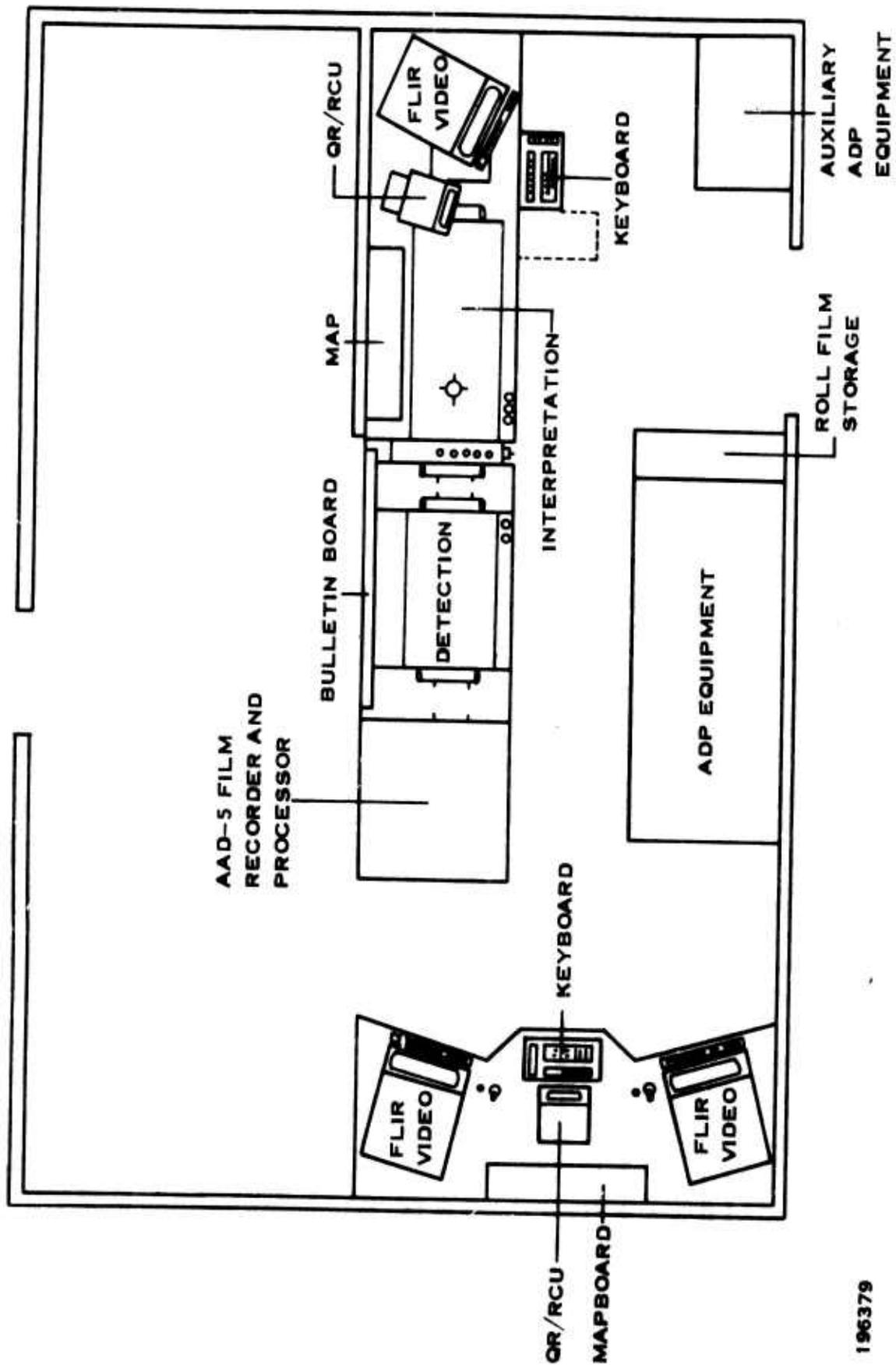

Figure 24. Recommended Test Configuration of the RRF

196379

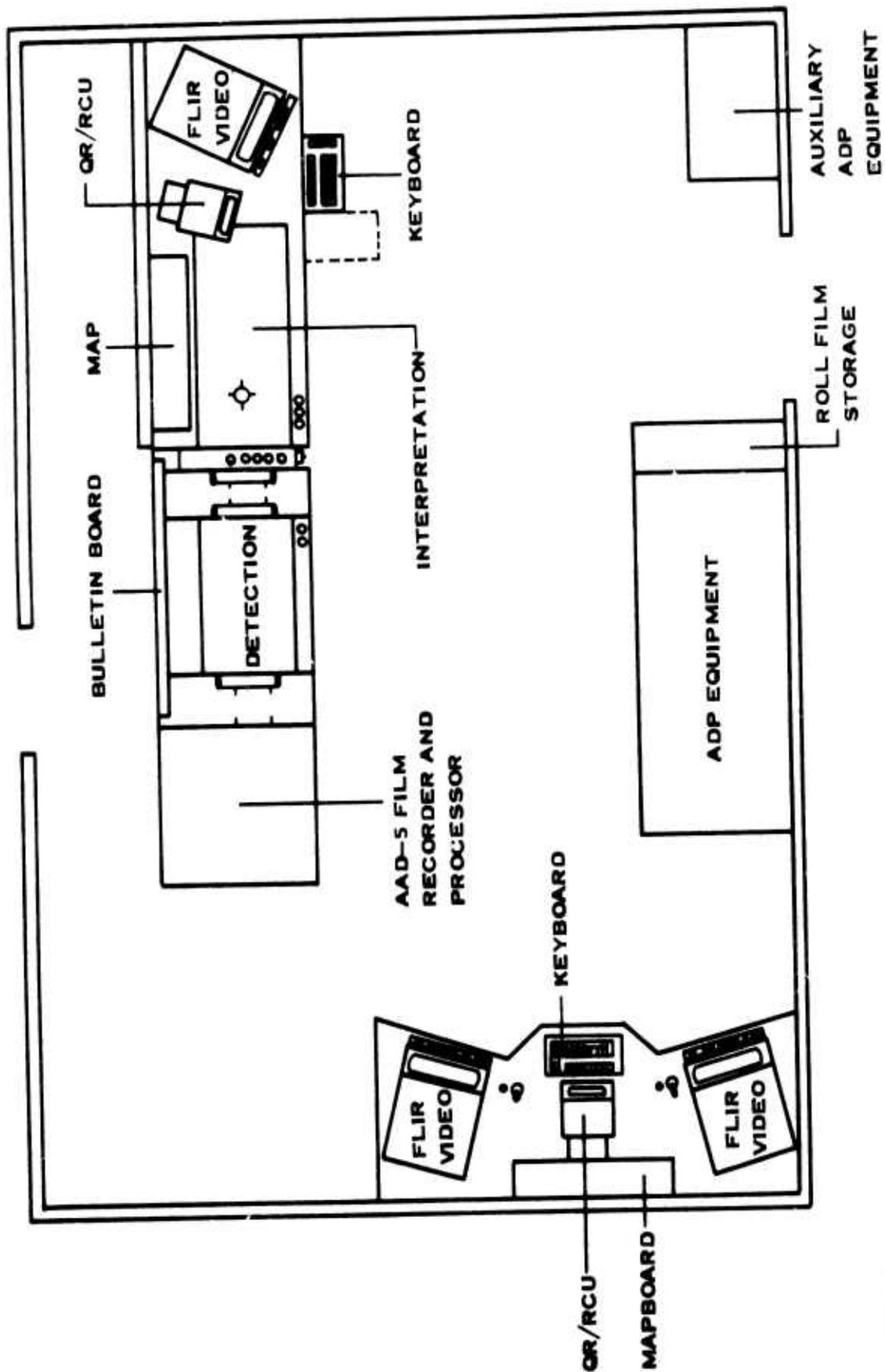

Figure 25. Recommended Demonstration Configuration of the RRF

196380

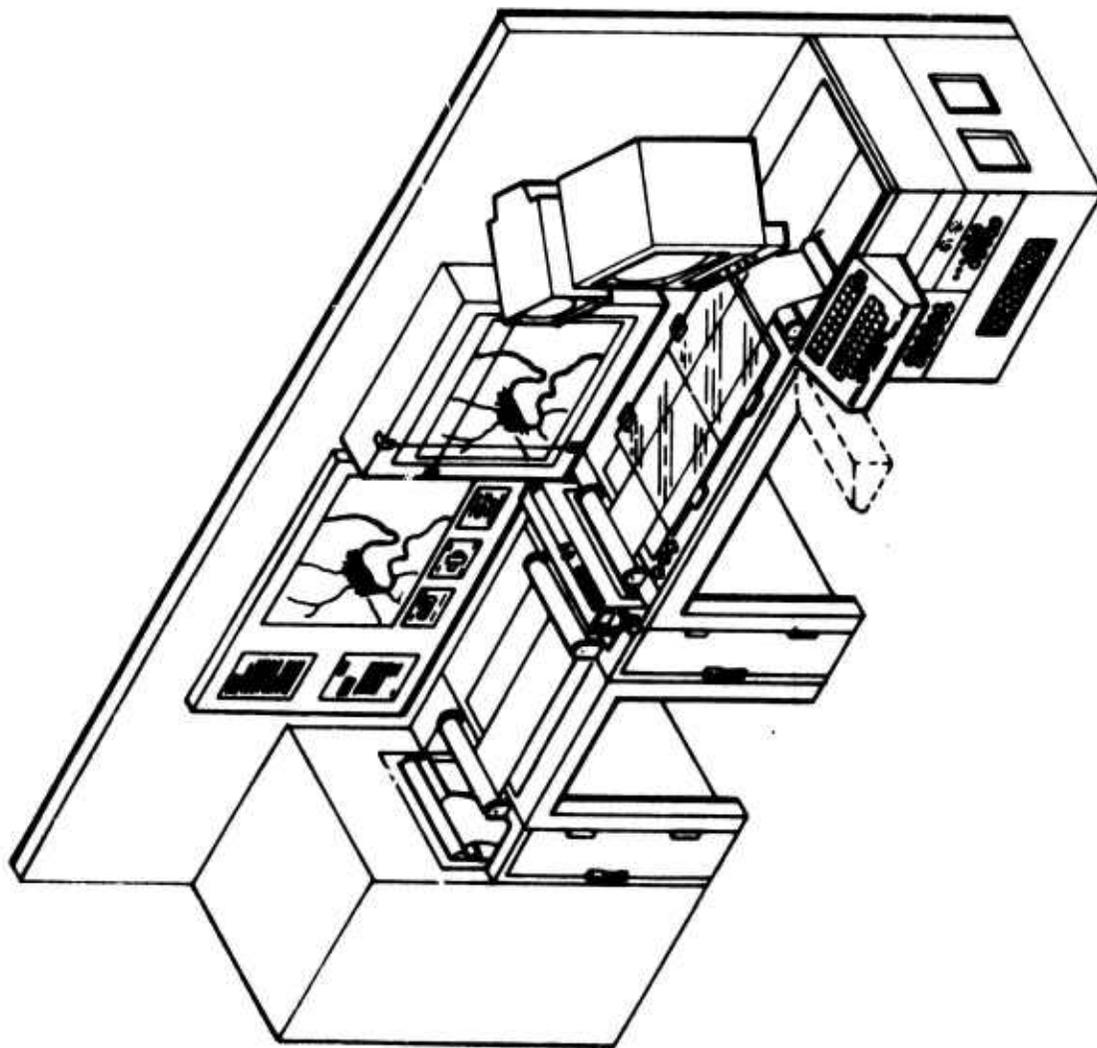

Figure 26. Isometric Drawing of AAD-5 Console

106381

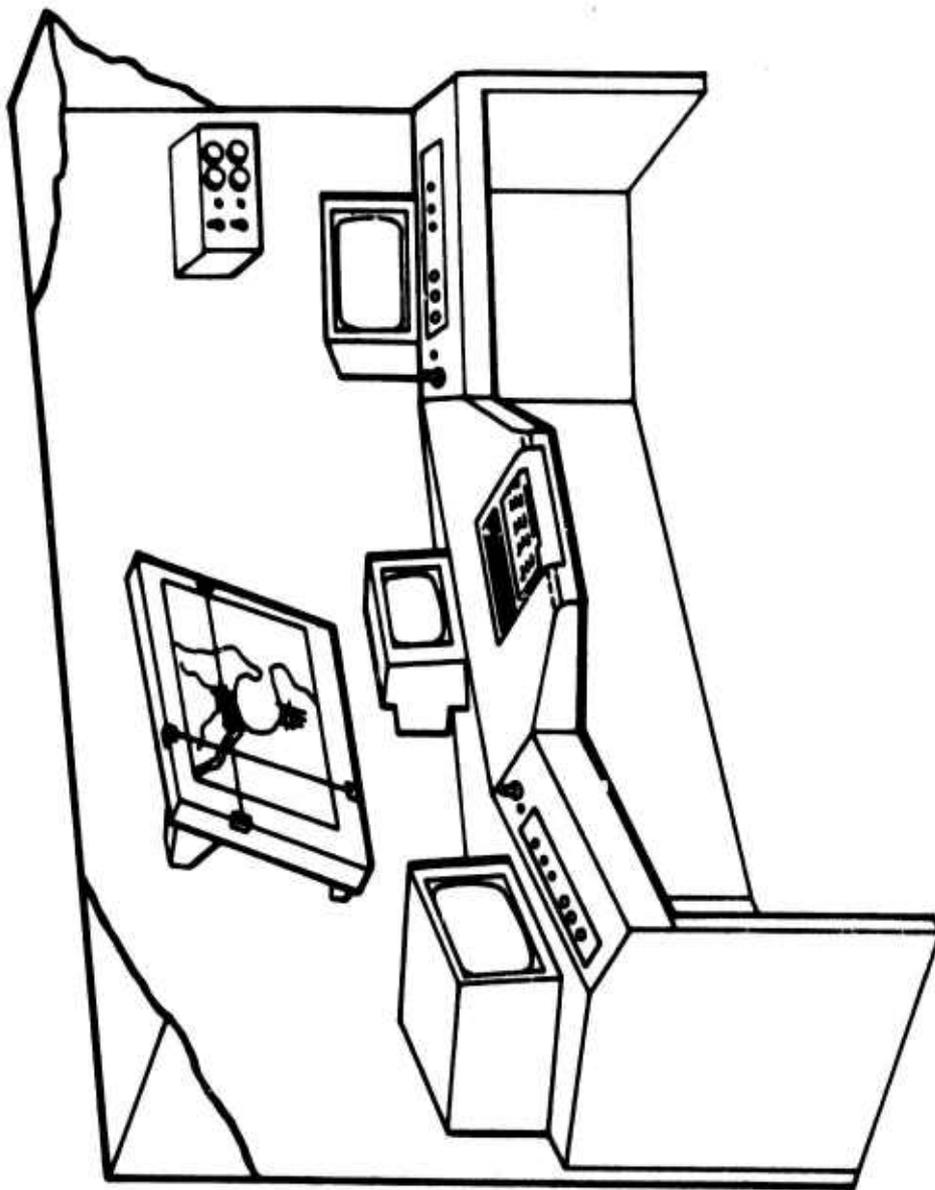

Figure 27. Isometric Drawing of FLIR Console

196382

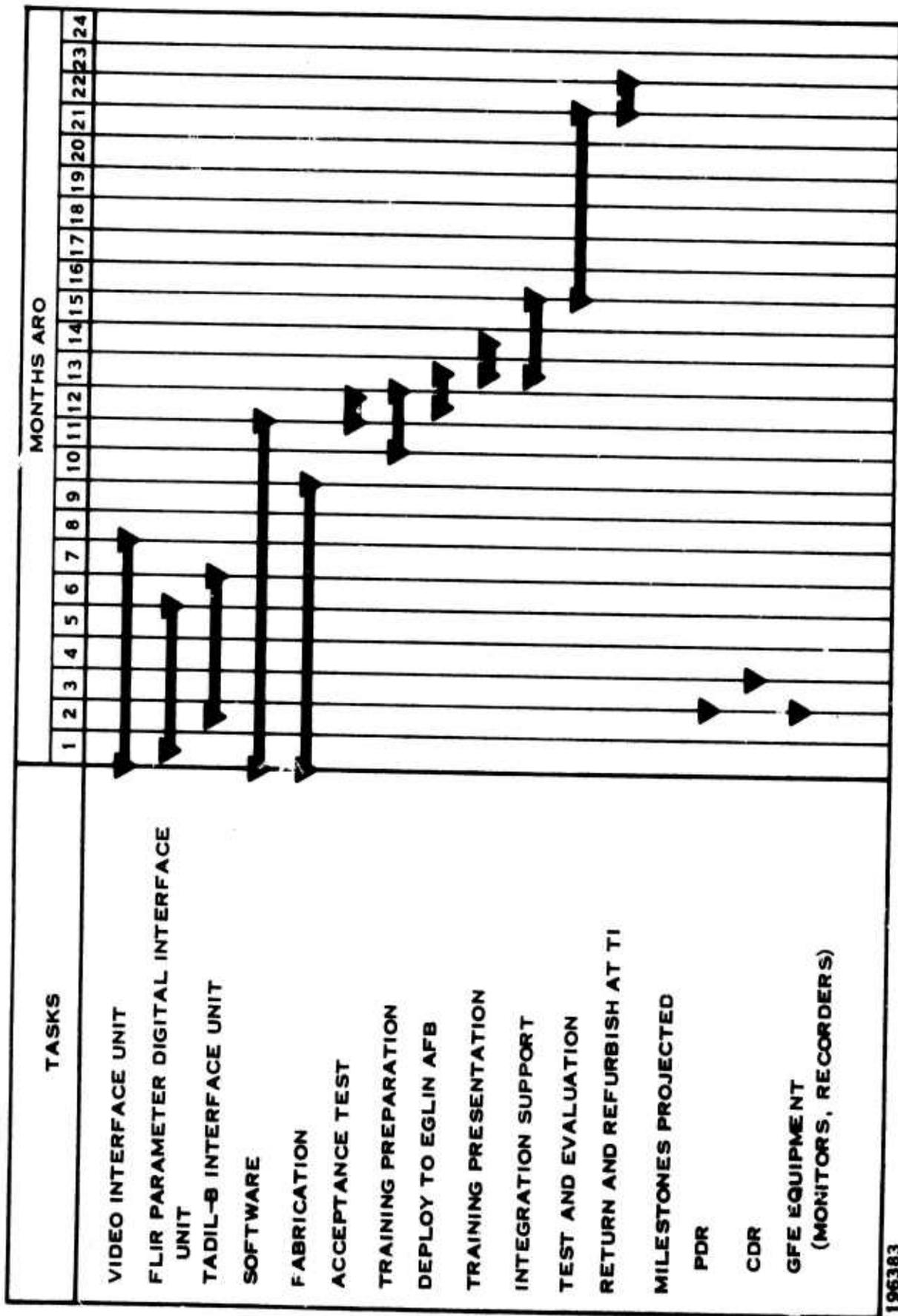

Figure 28. Prototype Fabrication Schedule

196383

APPENDIX A
PICTORIAL PRESENTATION OF FLIR FUNCTIONS
WITHIN QSR-RRF

This appendix provides a pictorial presentation of the FLIR functions occurring within the Quick Strike Reconnaissance (QSR) Reconnaissance Reporting Facility (RRF). These tasks are organized into six functional areas of operation: RRF initialization, mission preparation, mission search/scan mode, final target interpretation, report generation and dissemination, and detailed analysis and postmission update. Each basic functional area consists of a grouping of those specific functions that occur within the QSR-RRF.

There are two levels of detail used for presentation of these flows: the general first level and the more detailed second level. The first level flow depicts the general functions of the six functional areas as they occur within the QSR-RRF. The second level flow contains blocks representing the specific functions and decisions within the general functions that need to be accomplished.

The functional flows presented define the basic tasks of the QSR-RRF. Functional areas 1 through 5 define in detail the task of providing immediate exploitation of FLIR video and ADAS signal reconnaissance data for the purpose of immediate target assignment and subsequent strike. Functional area 6 defines the intelligence option available within the QSR-RRF for exploiting the FLIR data recorded on video tape for the purpose of extracting and disseminating additional intelligence information as well as retaining and using this data for QSR-RRF digital data base updates.

The initial flow diagram in this document is an introductory overview of the functional areas comprising the QSR-RRF. Each of the functional areas presented in this flow diagram (Figures A-1 through A-5) is later presented in terms of the two levels of detail.

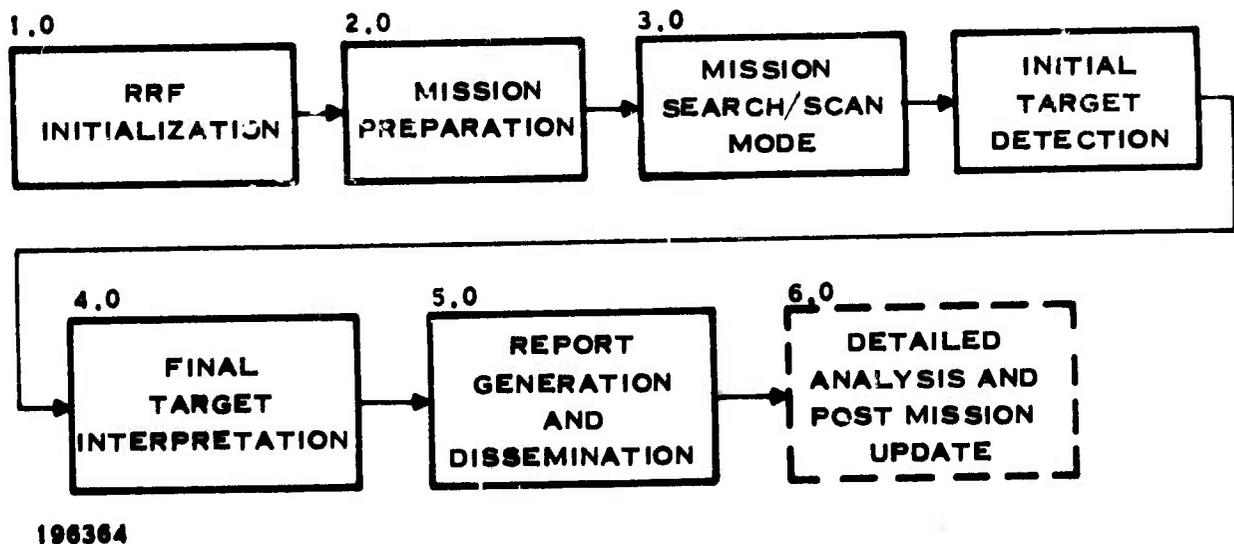
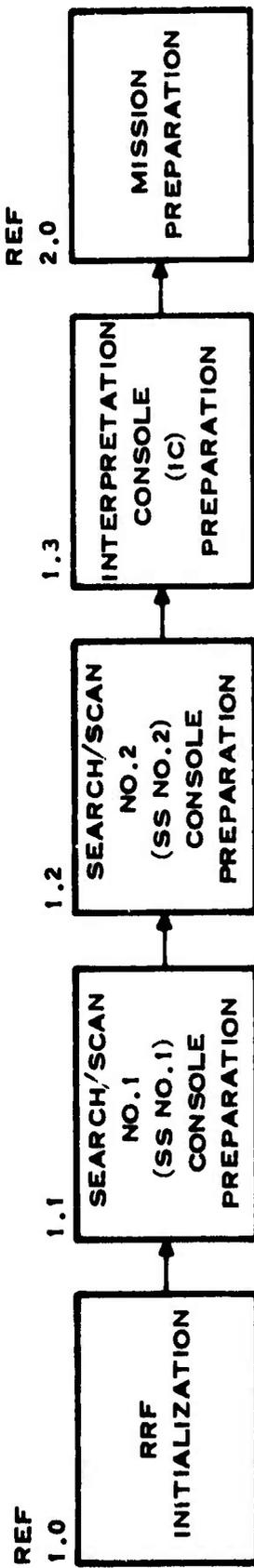

Figure A-1. Introductory Overview



FIRST LEVEL FLOW

196385

Figure A-2. Functional Areas of RRF Initialization (Sheet 1 of 4)

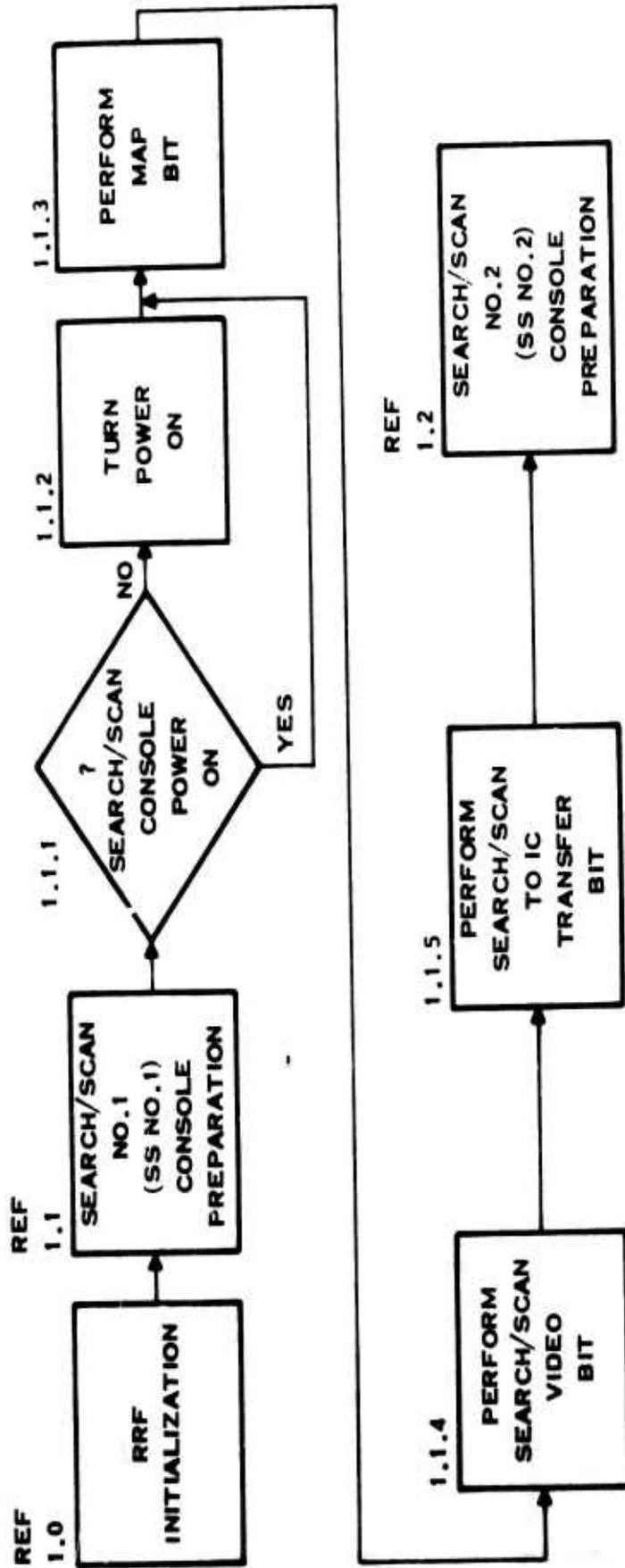

SECOND LEVEL FLOW

196386

Figure A-2. Functional Areas of RRF Initialization (Sheet 2 of 4)

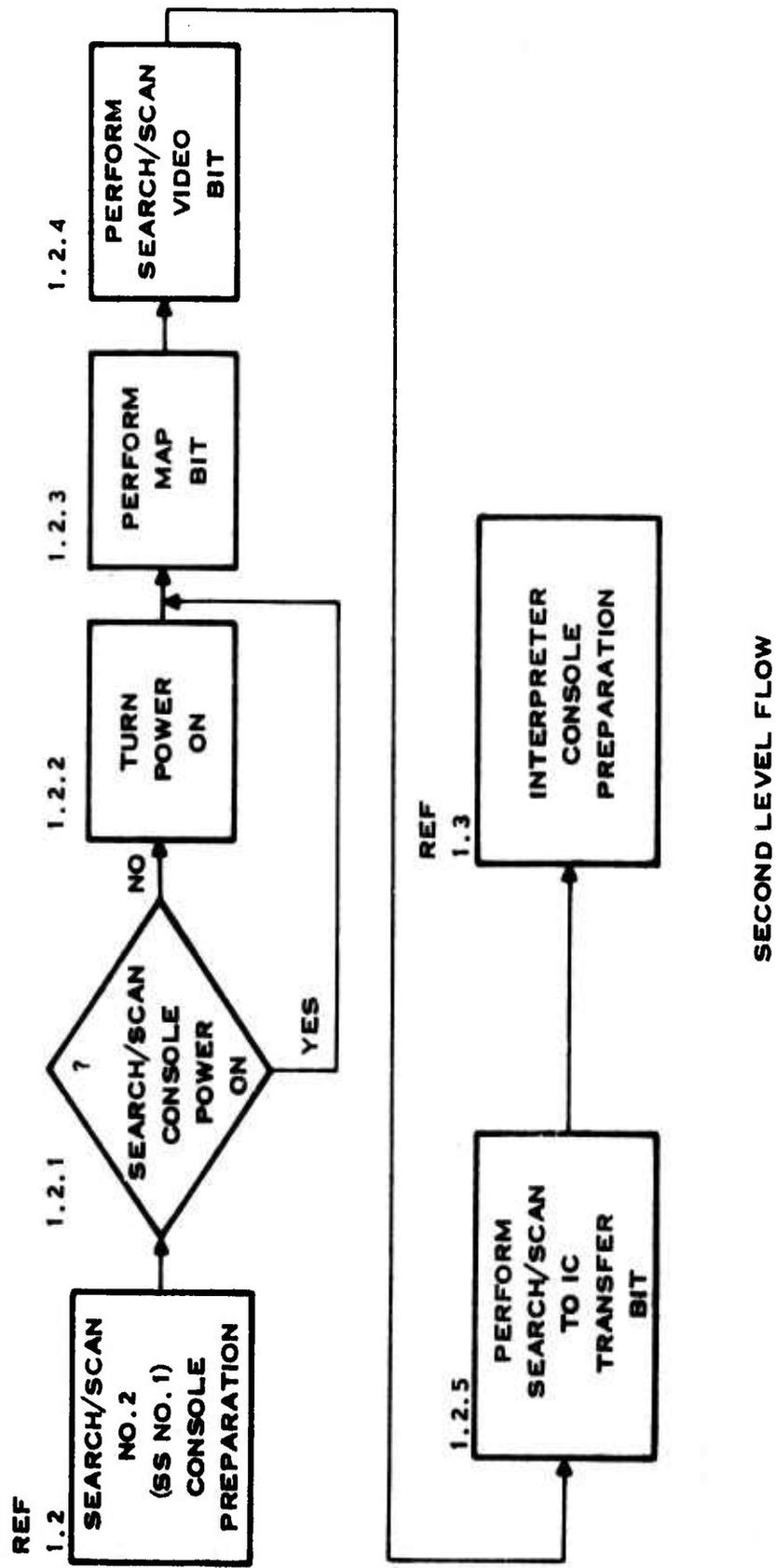

196387

Figure A-2. Functional Areas of RRF Initialization (Sheet 3 of 4)

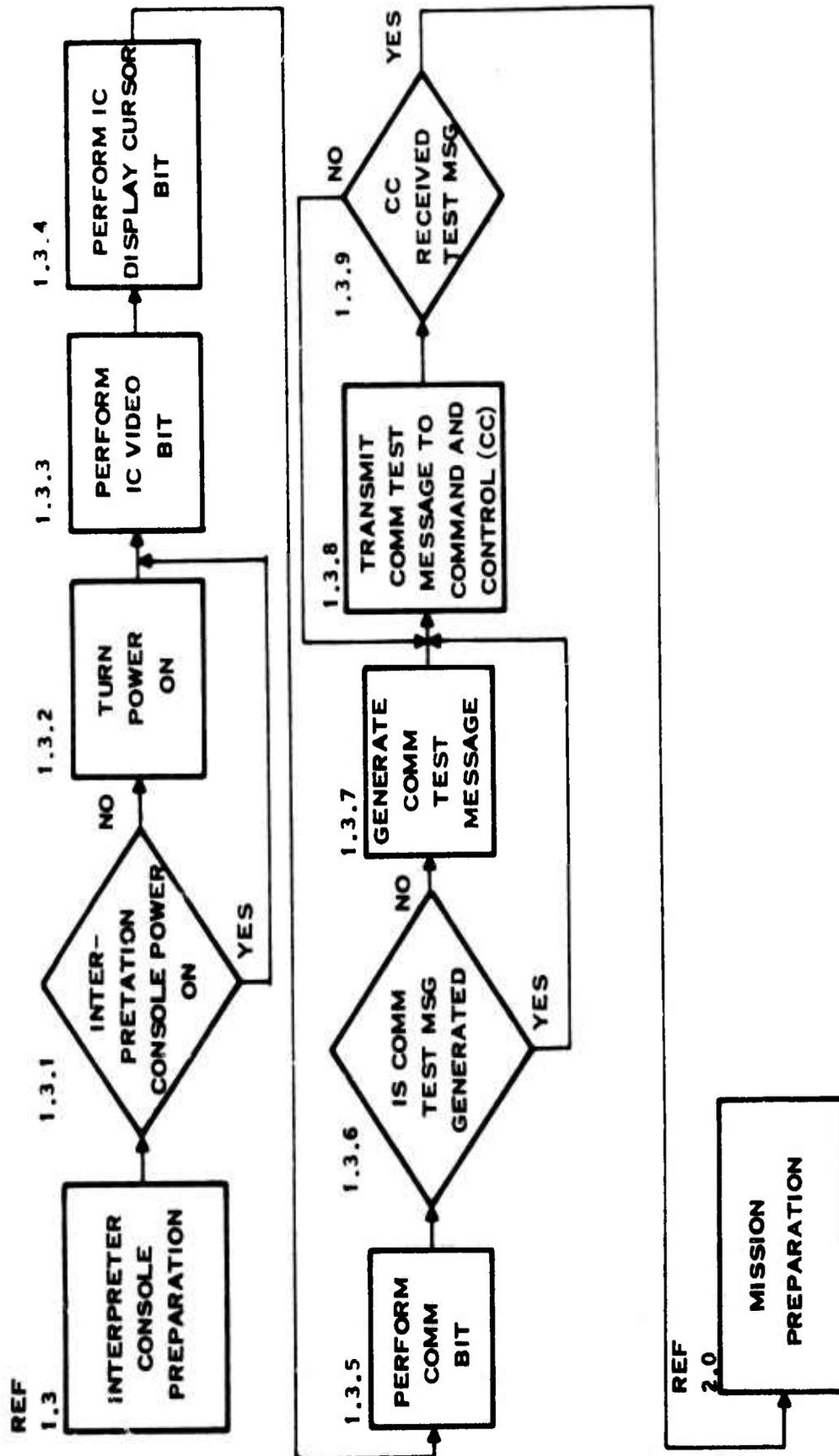

SECOND LEVEL FLOW

Figure A-2. Functional Areas of RRF Initialization (Sheet 4 of 4)

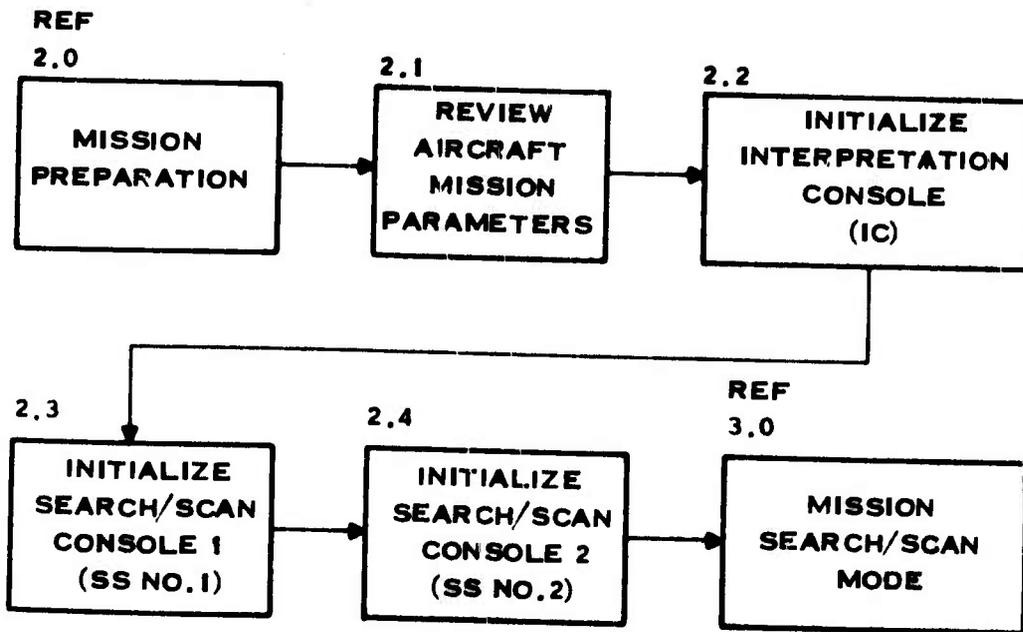

FIRST LEVEL FLOW

196389

Figure A-3. Functional Areas of Mission Preparation (Sheet 1 of 12)

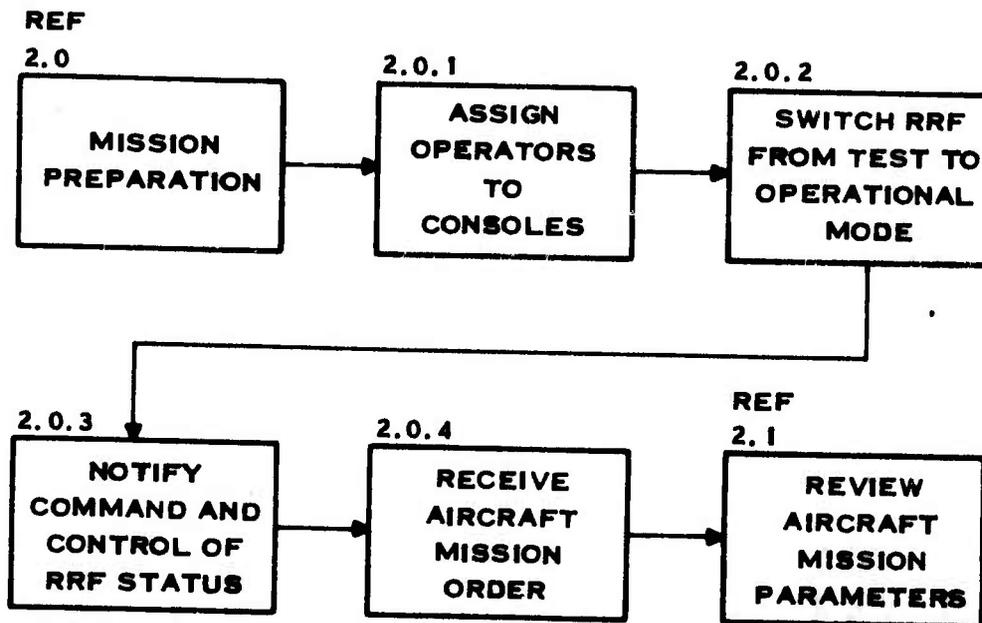

SECOND LEVEL FLOW

196390

Figure A-3. Functional Areas of Mission Preparation (Sheet 2 of 12)

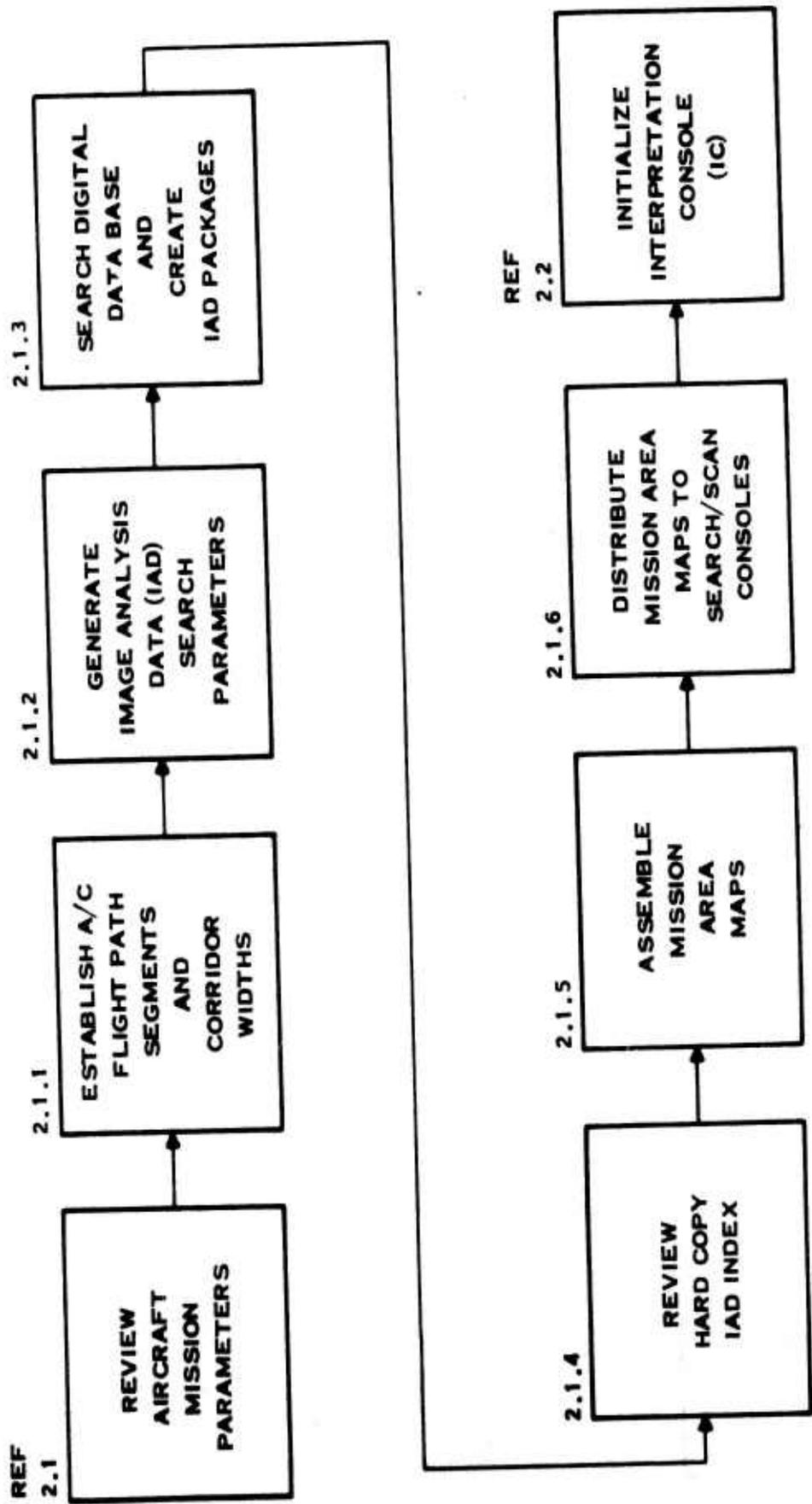

SECOND LEVEL FLOW

Figure A-3. Functional Areas of Mission Preparation (Sheet 3 of 12)

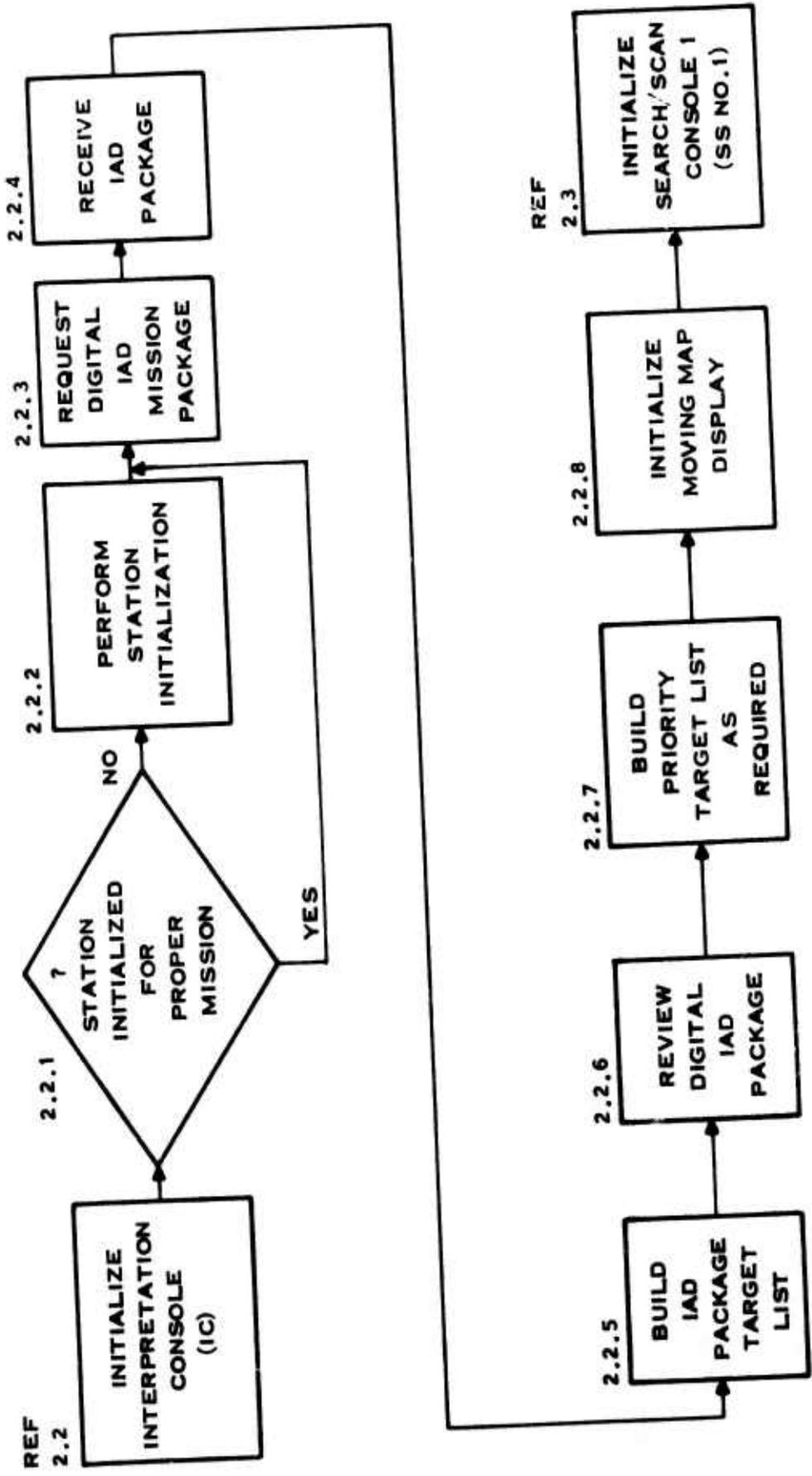

SECOND LEVEL FLOW

Figure A-3. Functional Areas of Mission Preparation (Sheet 4 of 12)

196392

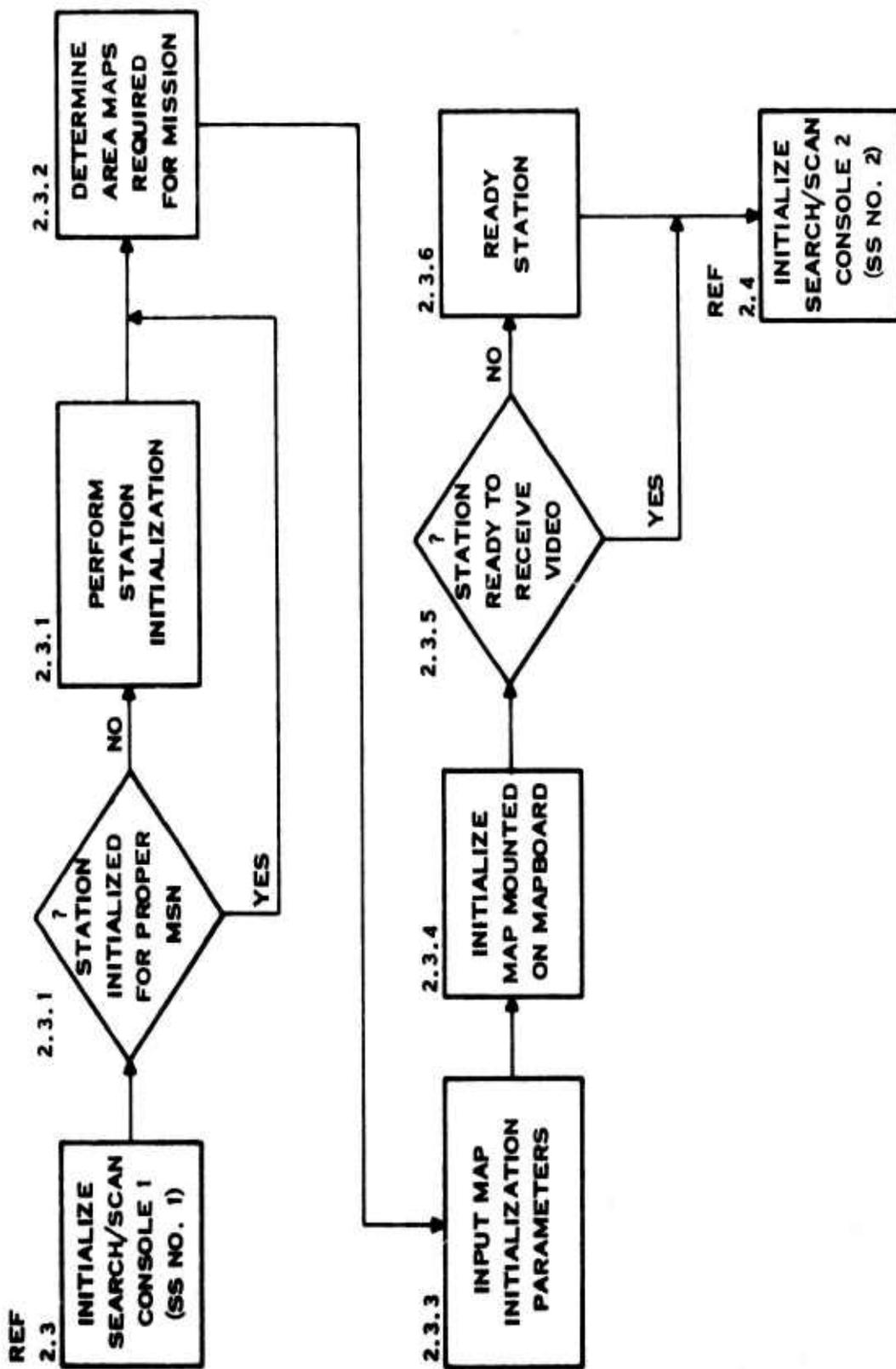

SECOND LEVEL FLOW

Figure A-3. Functional Areas of Mission Preparation (Sheet 5 of 12)

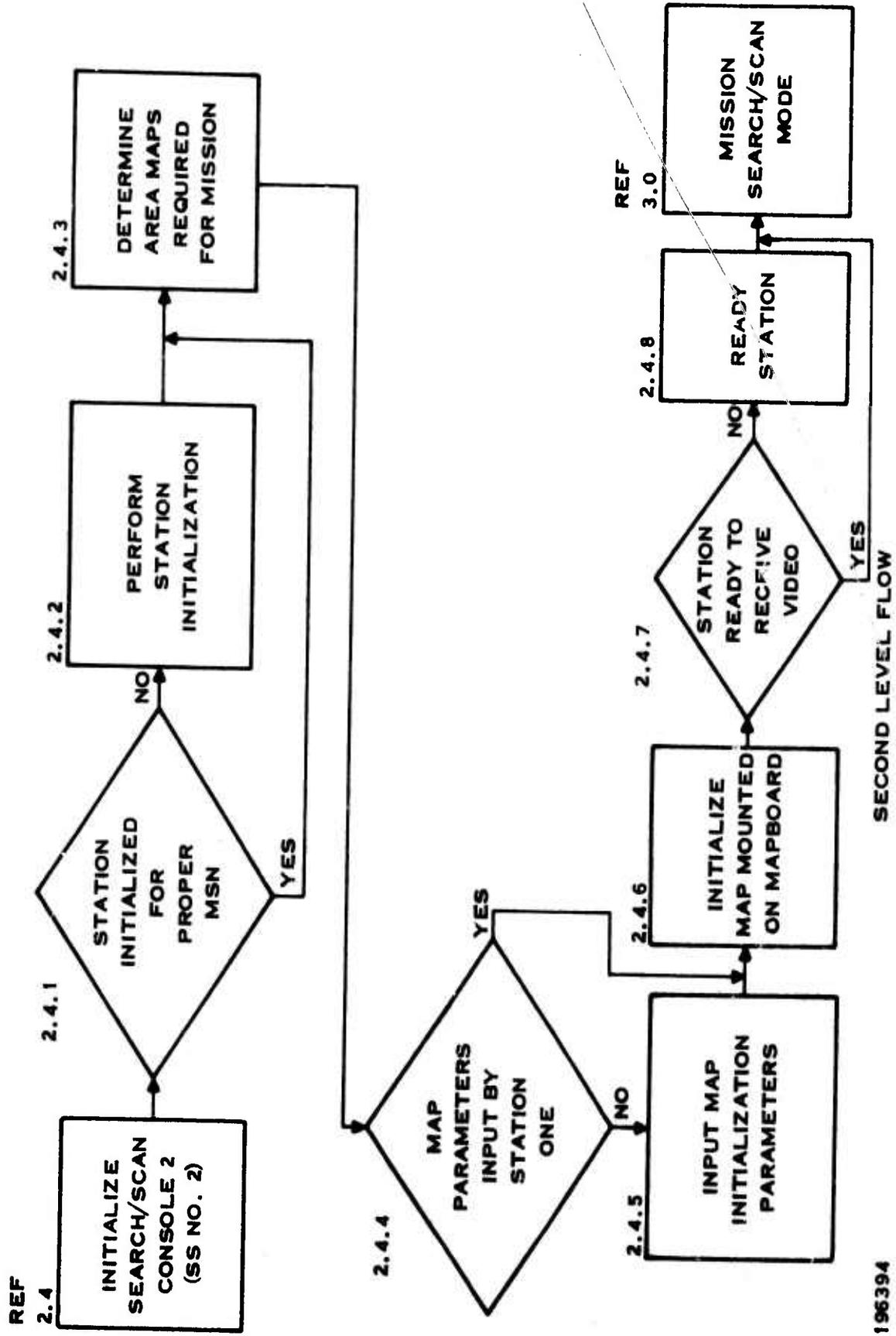

Figure A-3. Functional Areas of Mission Preparation (Sheet 6 of 12)

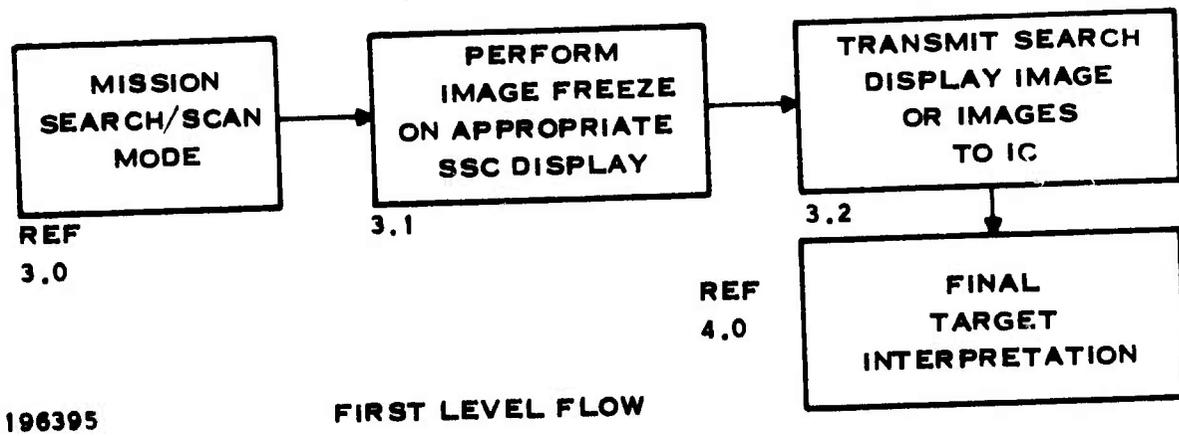
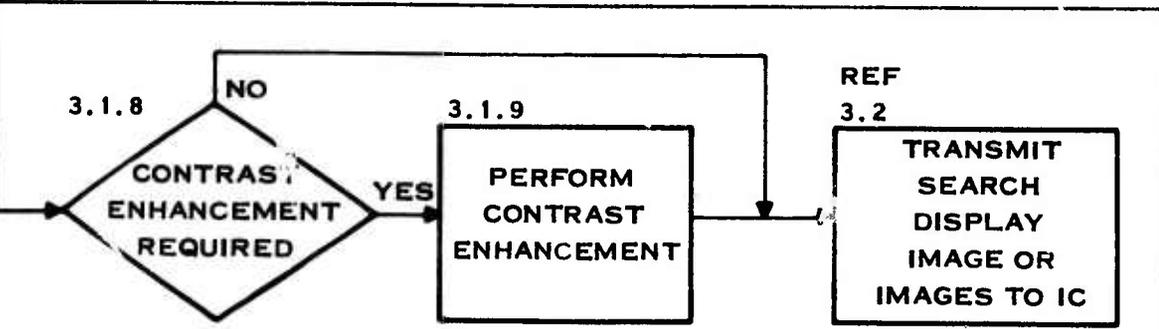
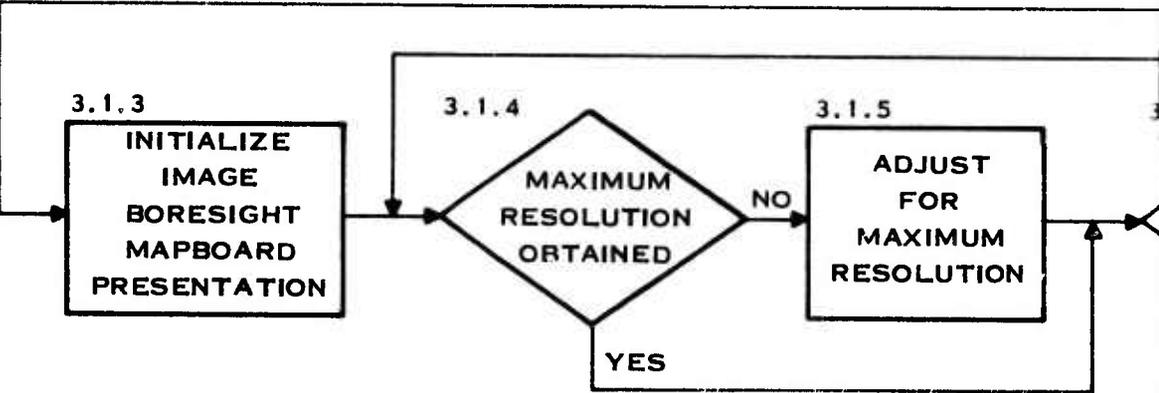
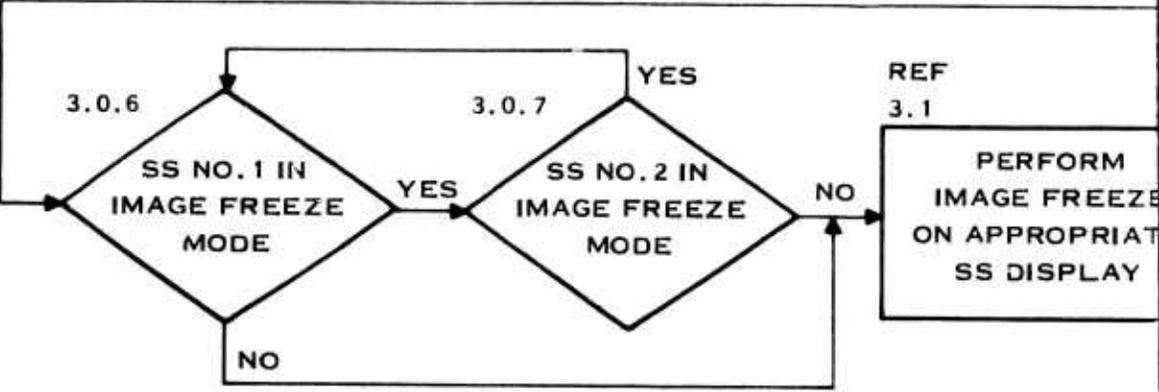
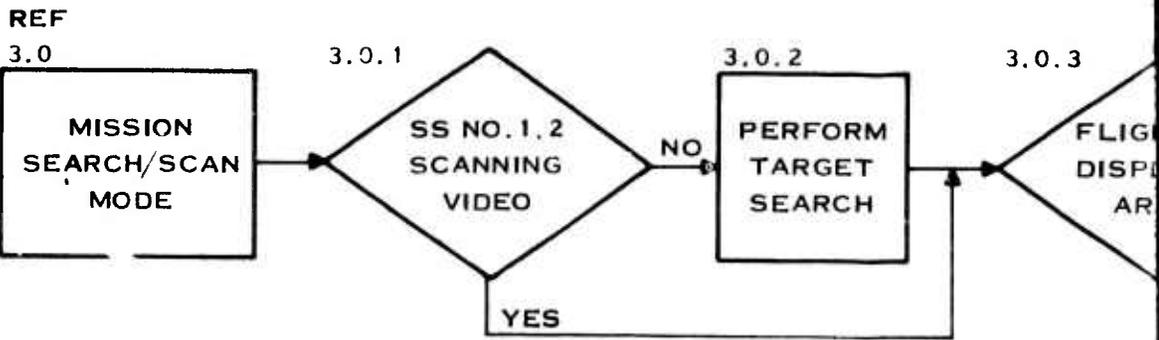
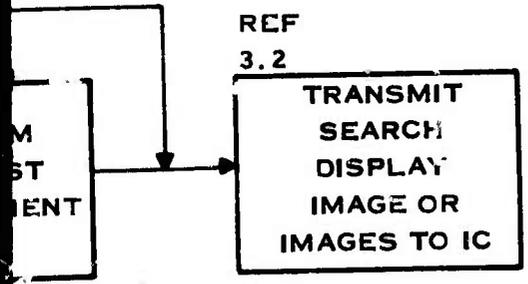
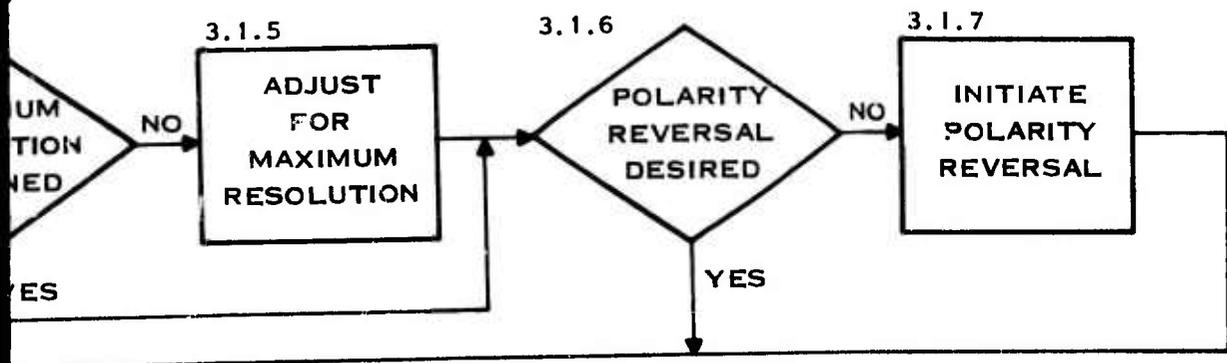
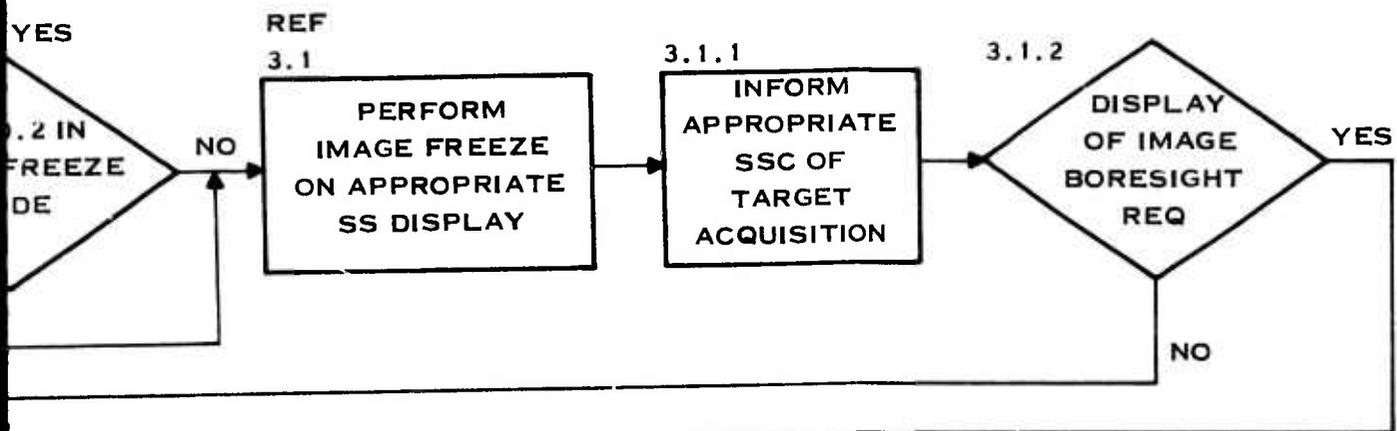
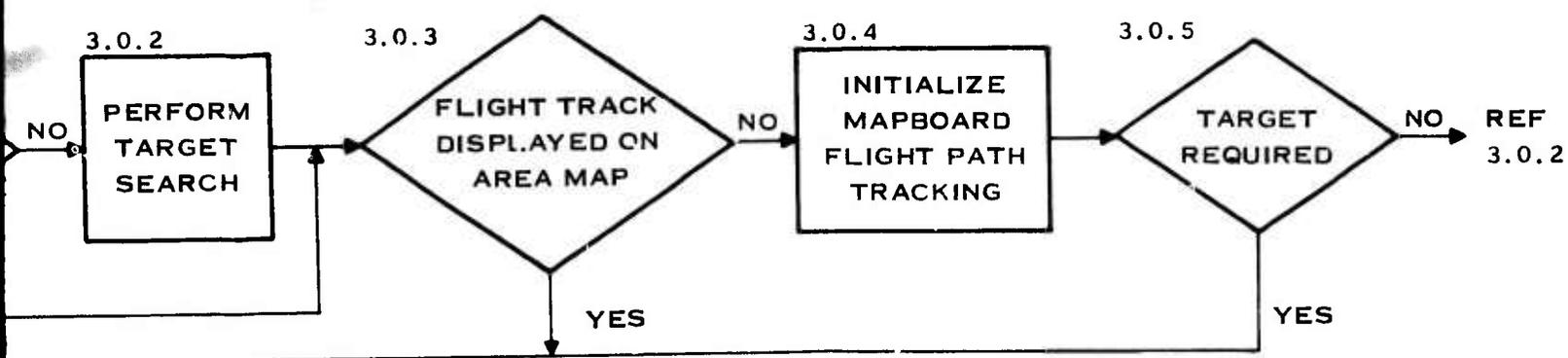

Figure A-3. Functional Areas of Mission Preparation (Sheet 7 of 12)





SECOND LEVEL FLOW

Figure A-3. Functional Areas of Mission Preparation (Sheet 8 of 12)

2

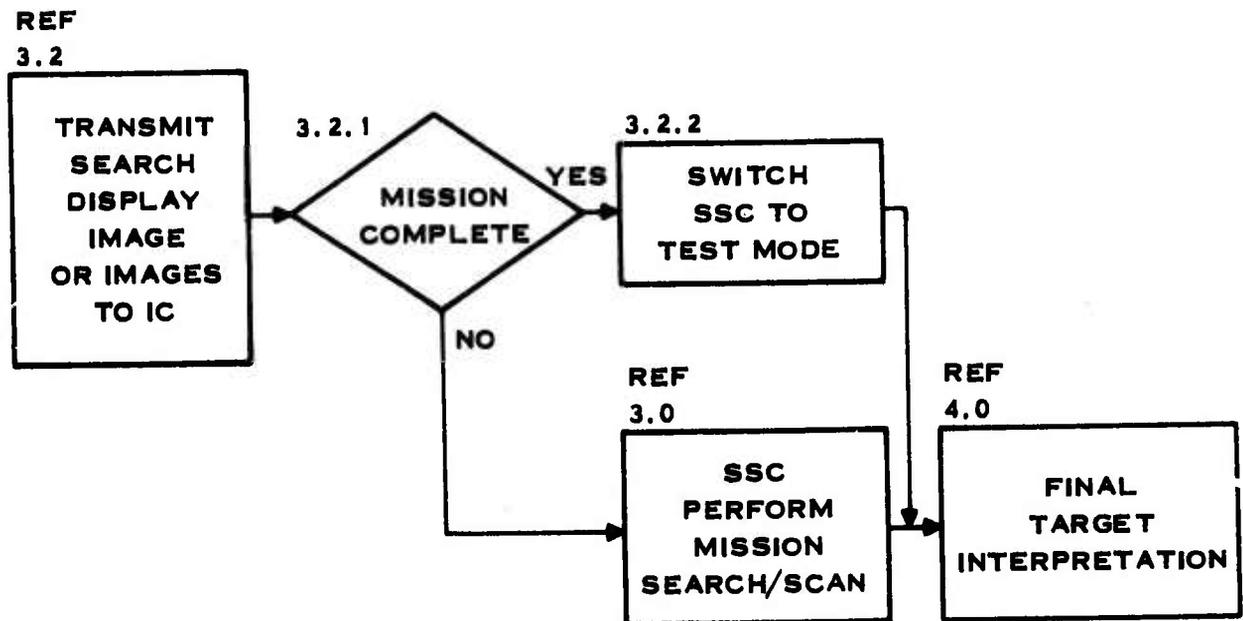

SECOND LEVEL FLOW

196397

Figure A-3. Functional Areas of Mission Preparation (Sheet 9 of 12)

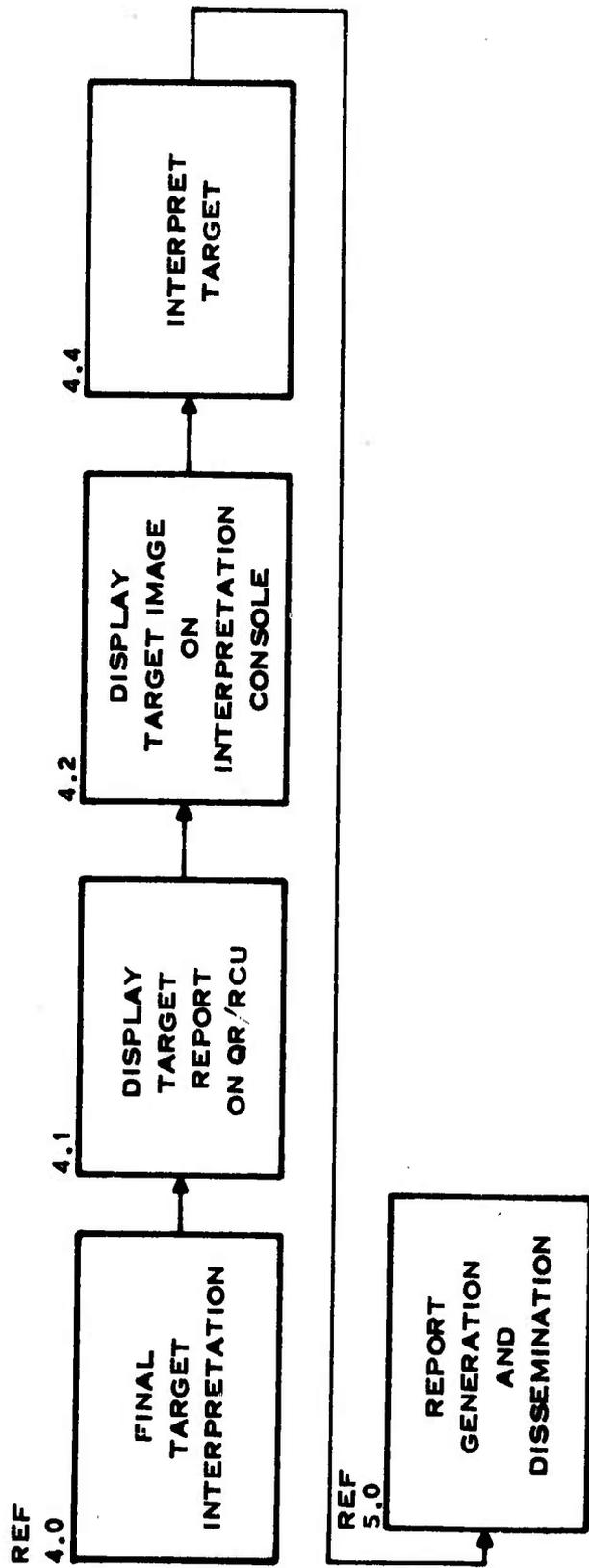

FIRST LEVEL FLOW

Figure A-3. Functional Areas of Mission Preparation (Sheet 10 of 12)

196398

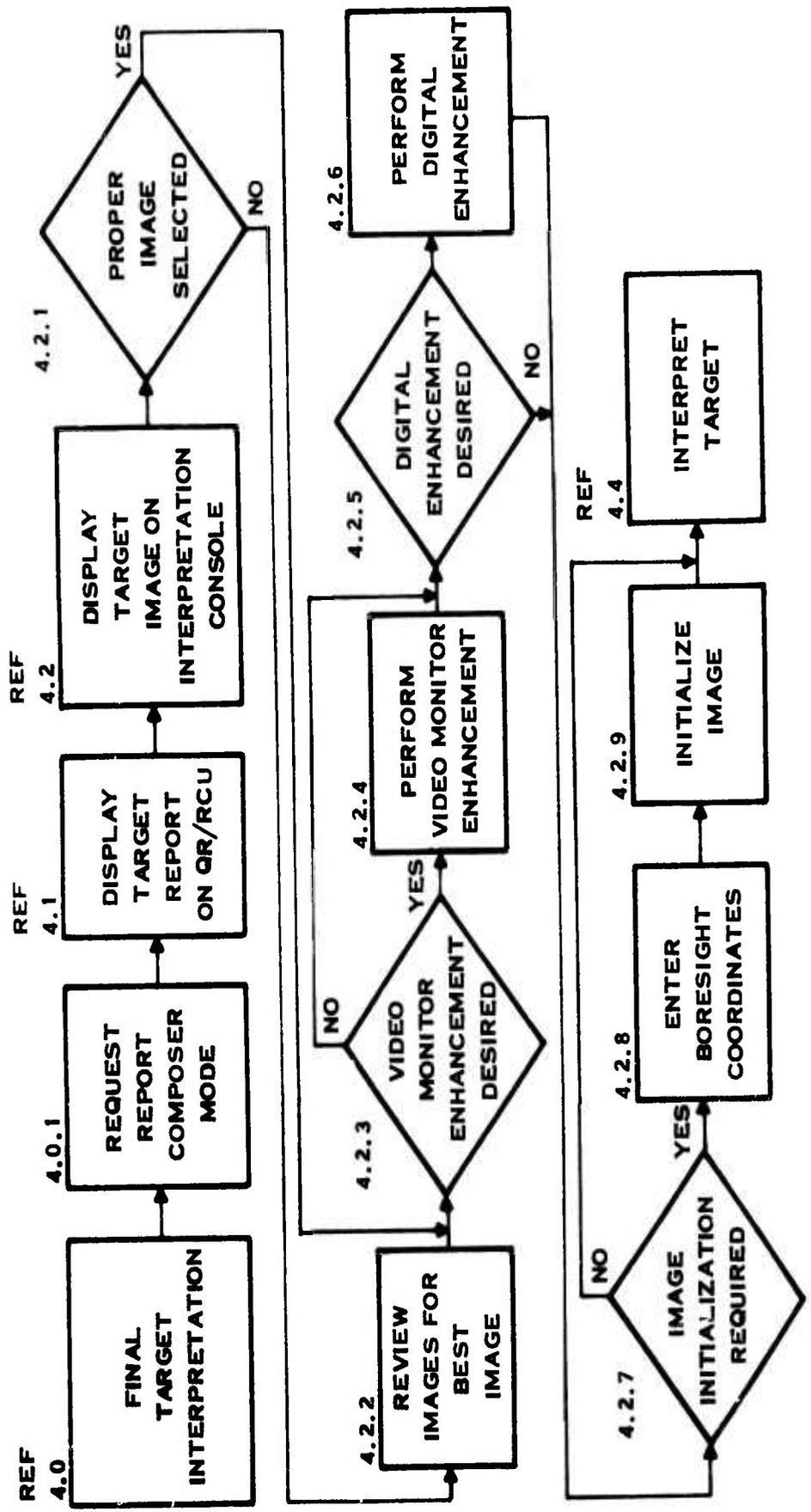

SECOND LEVEL FLOW

Figure A-3. Functional Areas of Mission Preparation (Sheet 11 of 12)

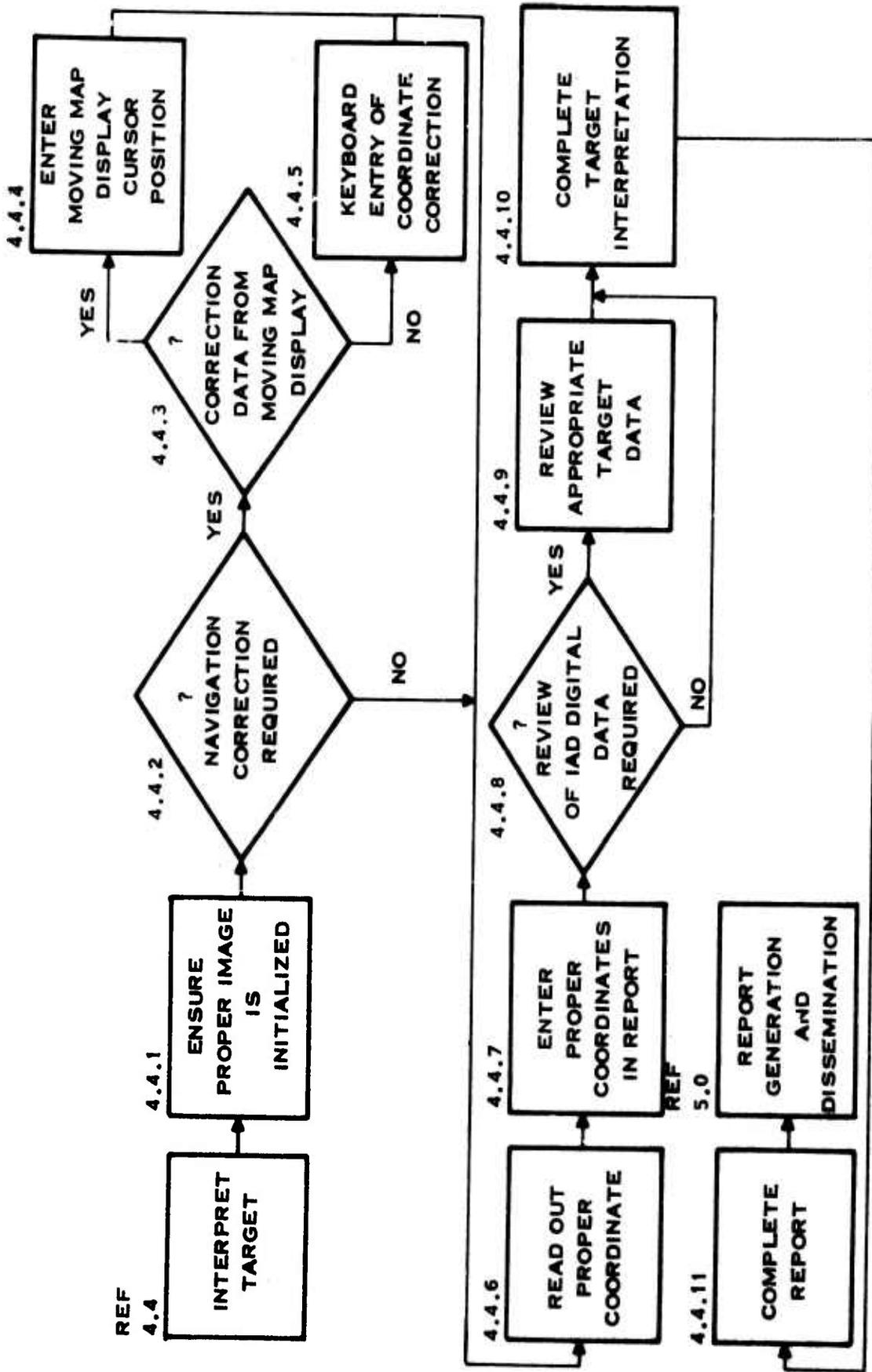

SECOND LEVEL DISPLAY

Figure A-3. Functional Areas of Mission Preparation (Sheet 12 of 12)

196400

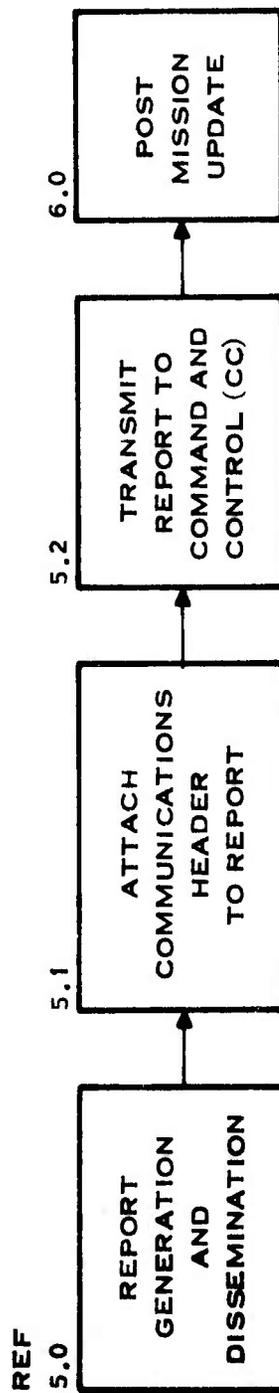

FIRST LEVEL FLOW

REF
5.0

6.0

5.2

5.1

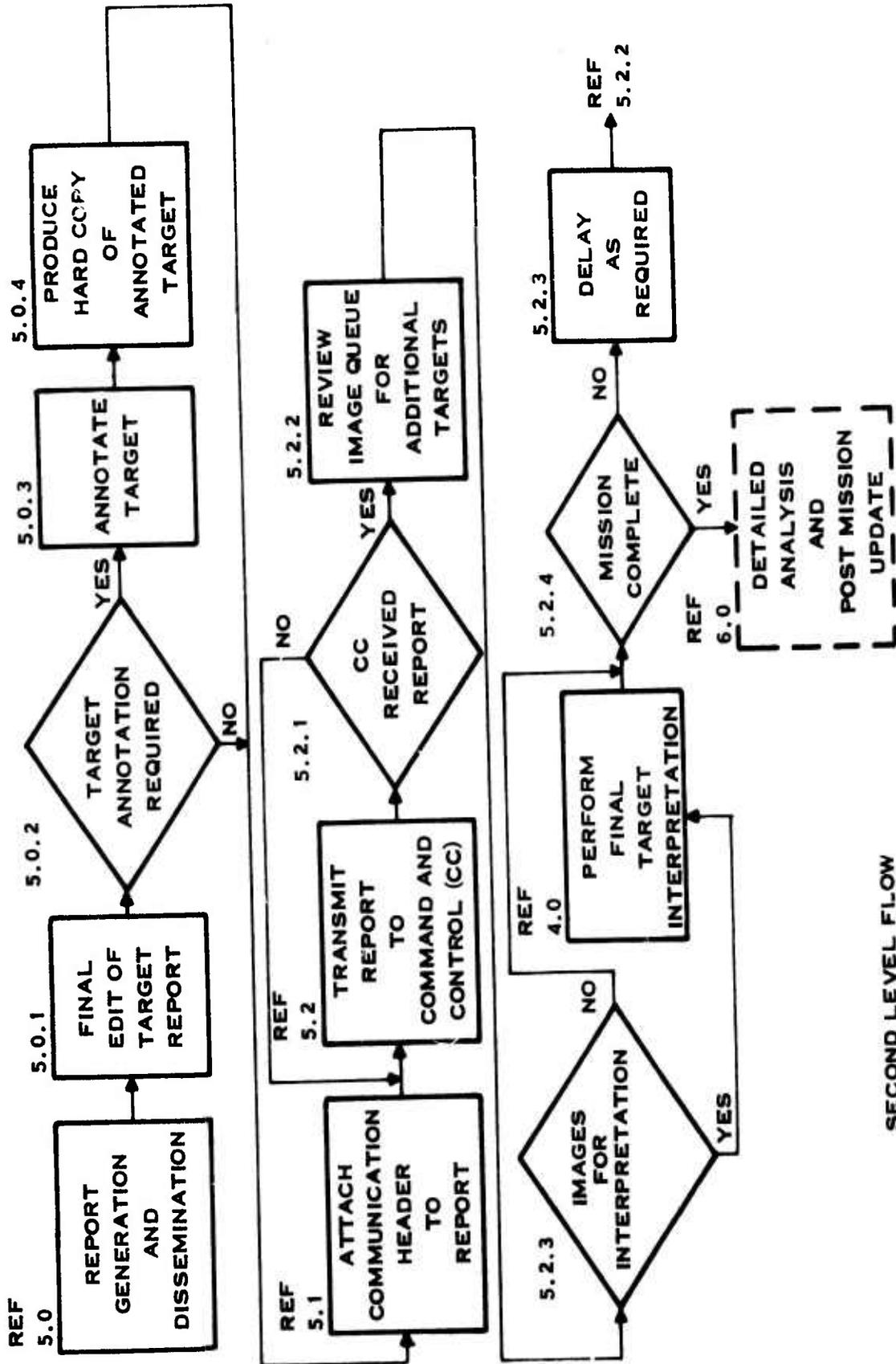

SECOND LEVEL FLOW

196 402

Figure A-4. Functional Areas of Report Generation and Dissemination (Sheet 2 of 3)

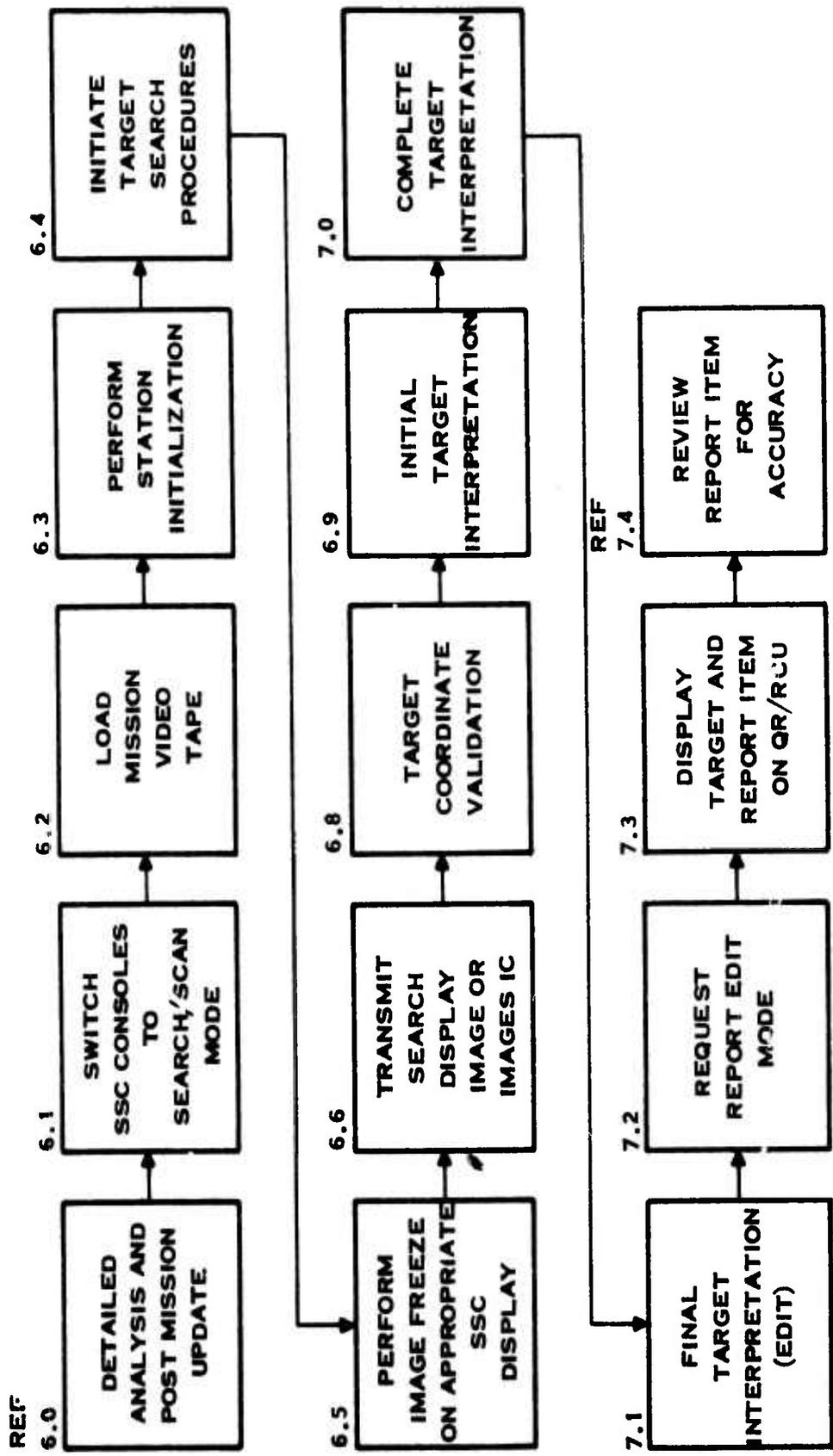

FIRST LEVEL FLOW

Figure A-4. Functional Areas of Report Generation and Dissemination (Sheet 3 of 3)

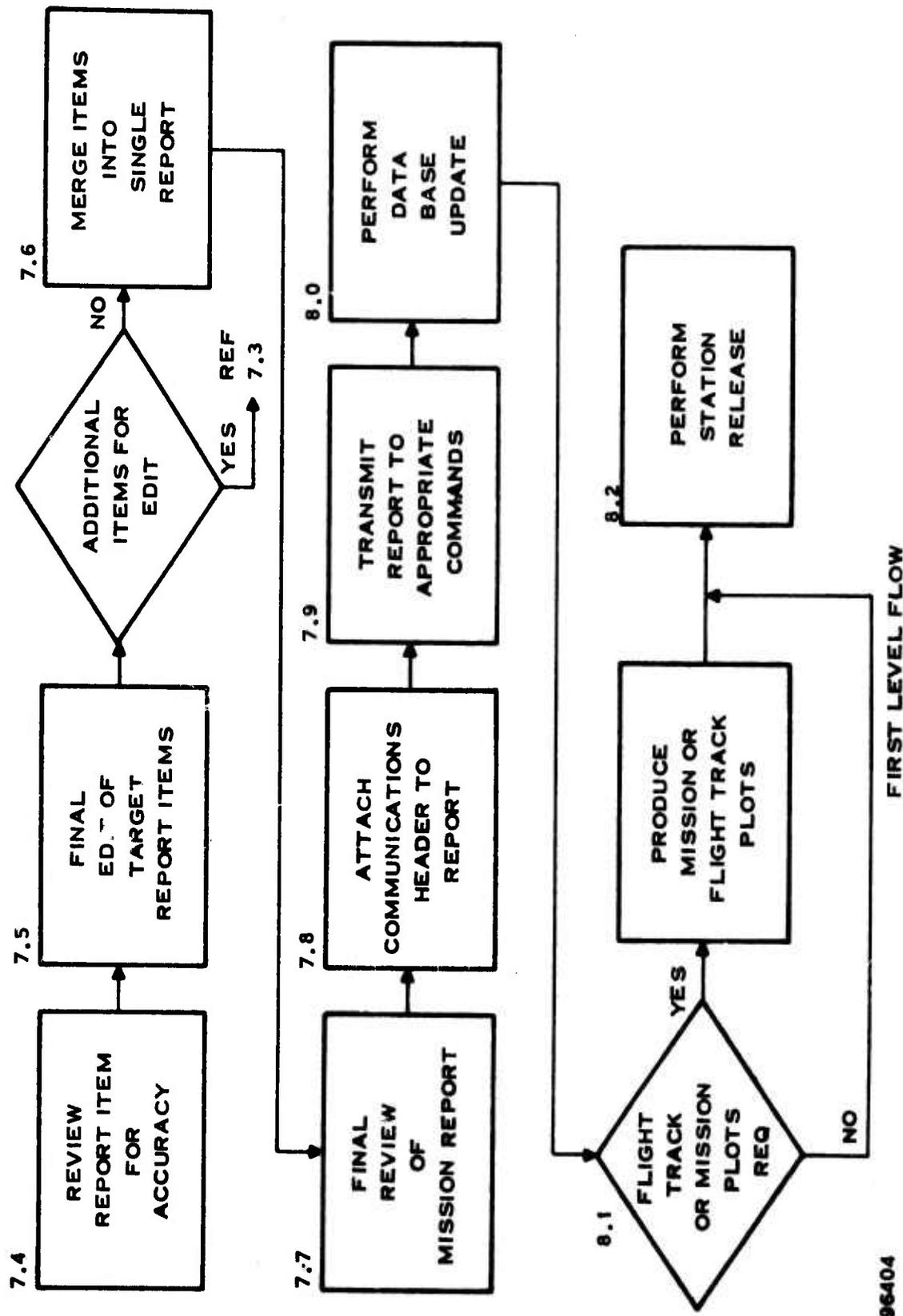

196404

FIRST LEVEL FLOW

Figure A-5. Functional Areas of Detailed Analysis and Post Mission Update (Sheet 1 of 8)

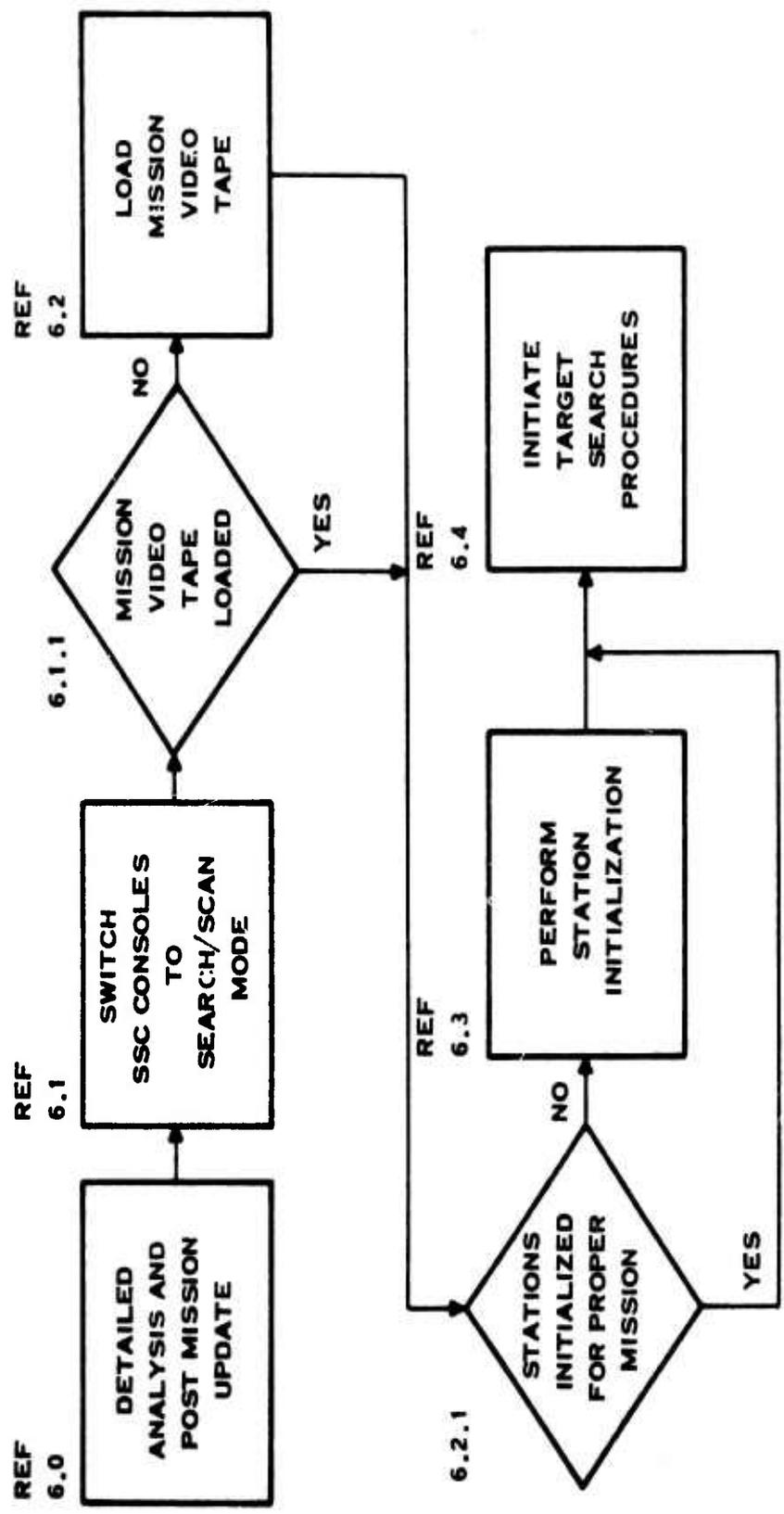

SECOND LEVEL FLOW

196405

Figure A-5. Functional Areas of Detailed Analysis and Post Mission Update (Sheet 2 of 8)

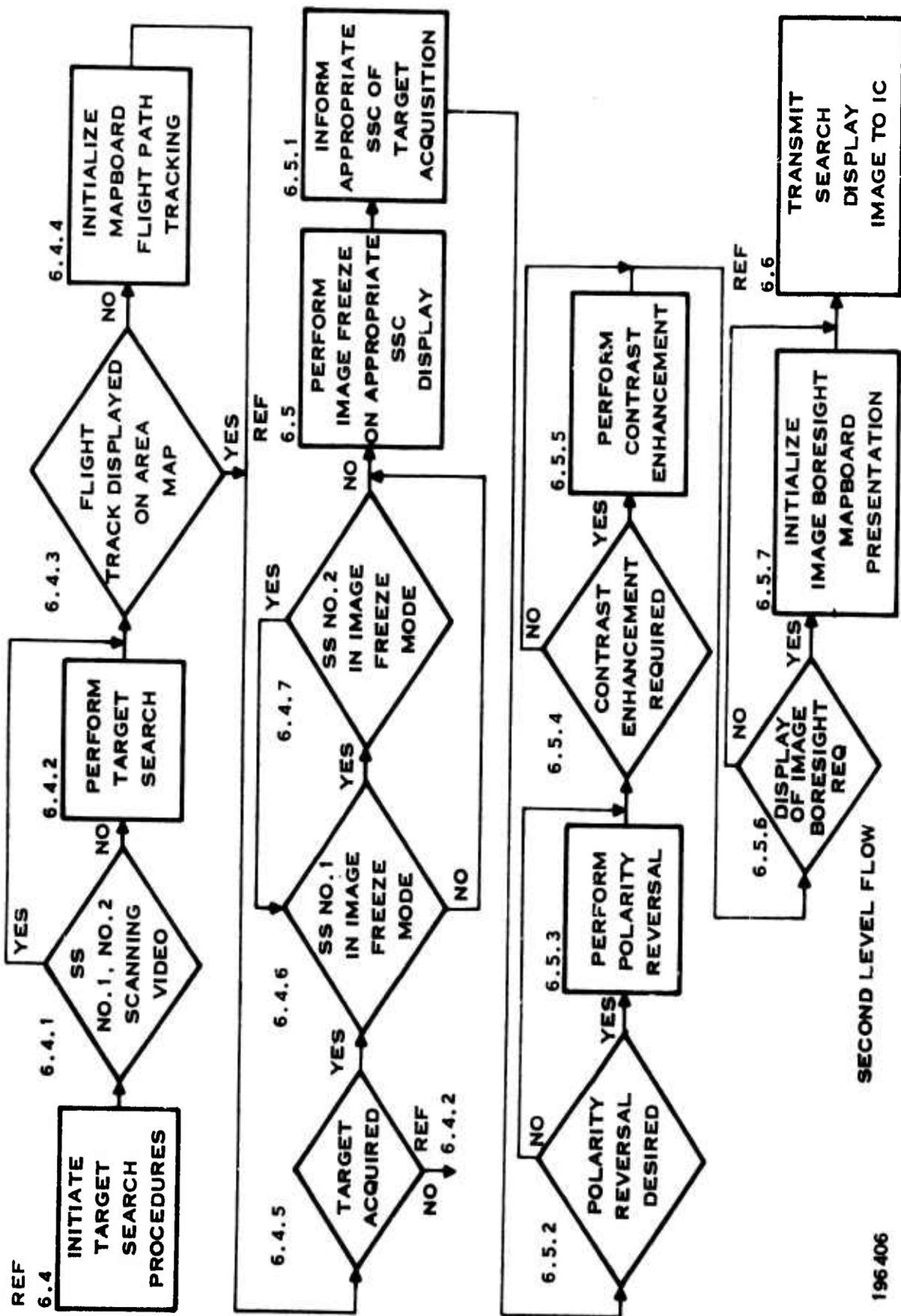

196406

SECOND LEVEL FLOW

Figure A-5. Functional Areas of Detailed Analysis and Post Mission Update (Sheet 3 of 8)

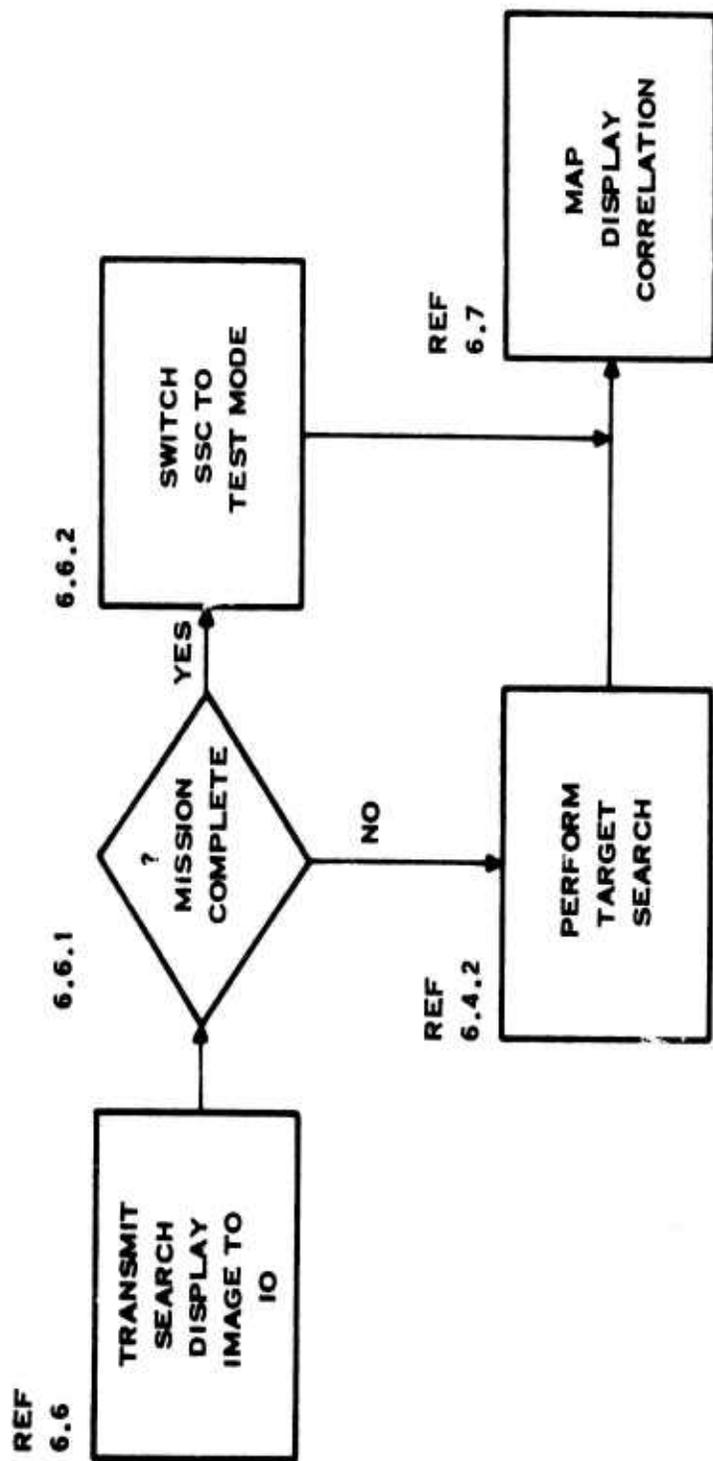

196407

SECOND LEVEL FLOW

Figure A-5. Functional Areas of Detailed Analysis and Post Mission Update (Sheet 4 of 8)

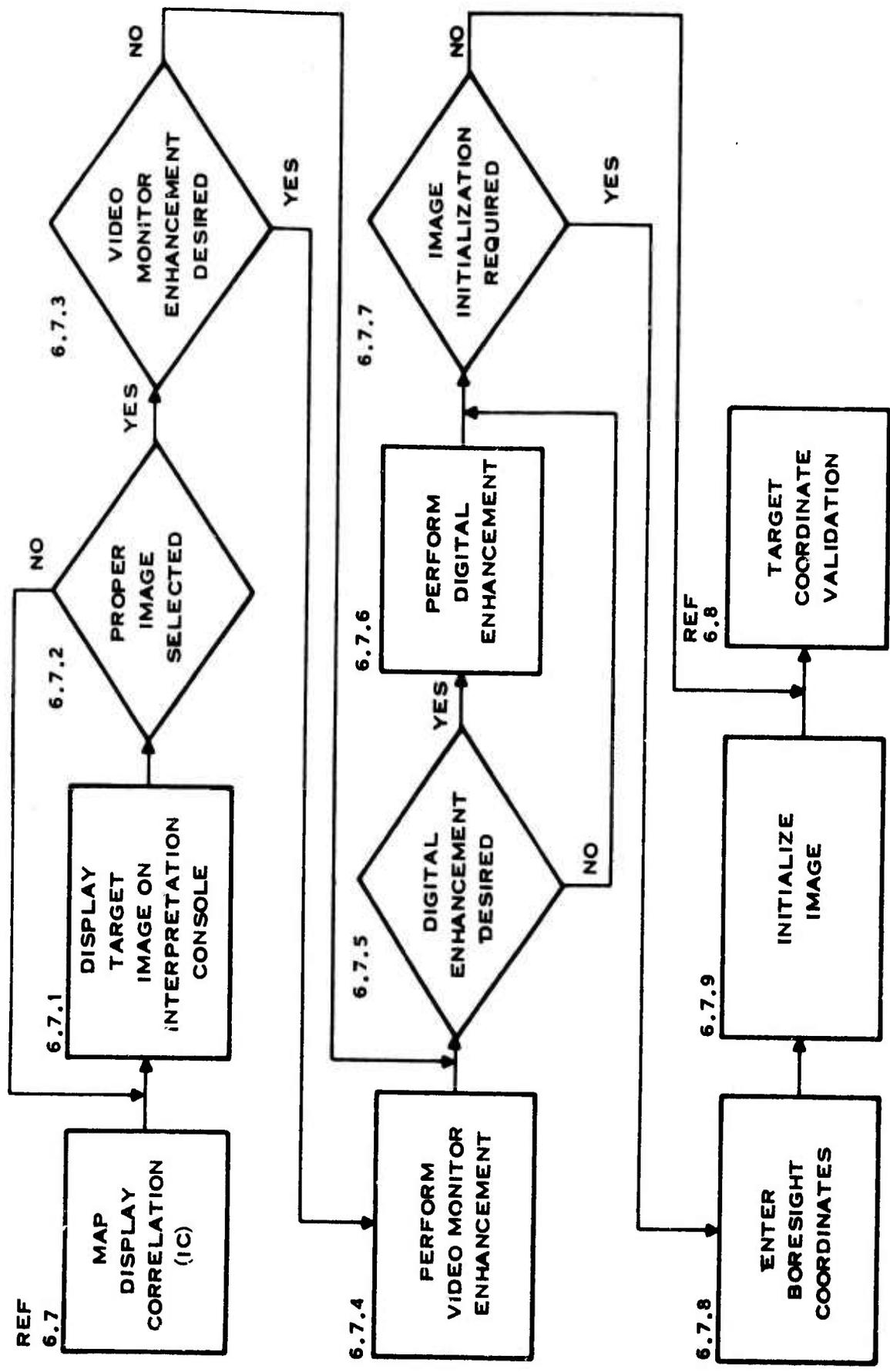

196408

SECOND LEVEL FLOW

Figure A-5. Functional Areas of Detailed Analysis and Post Mission Update (Sheet 5 of 8)

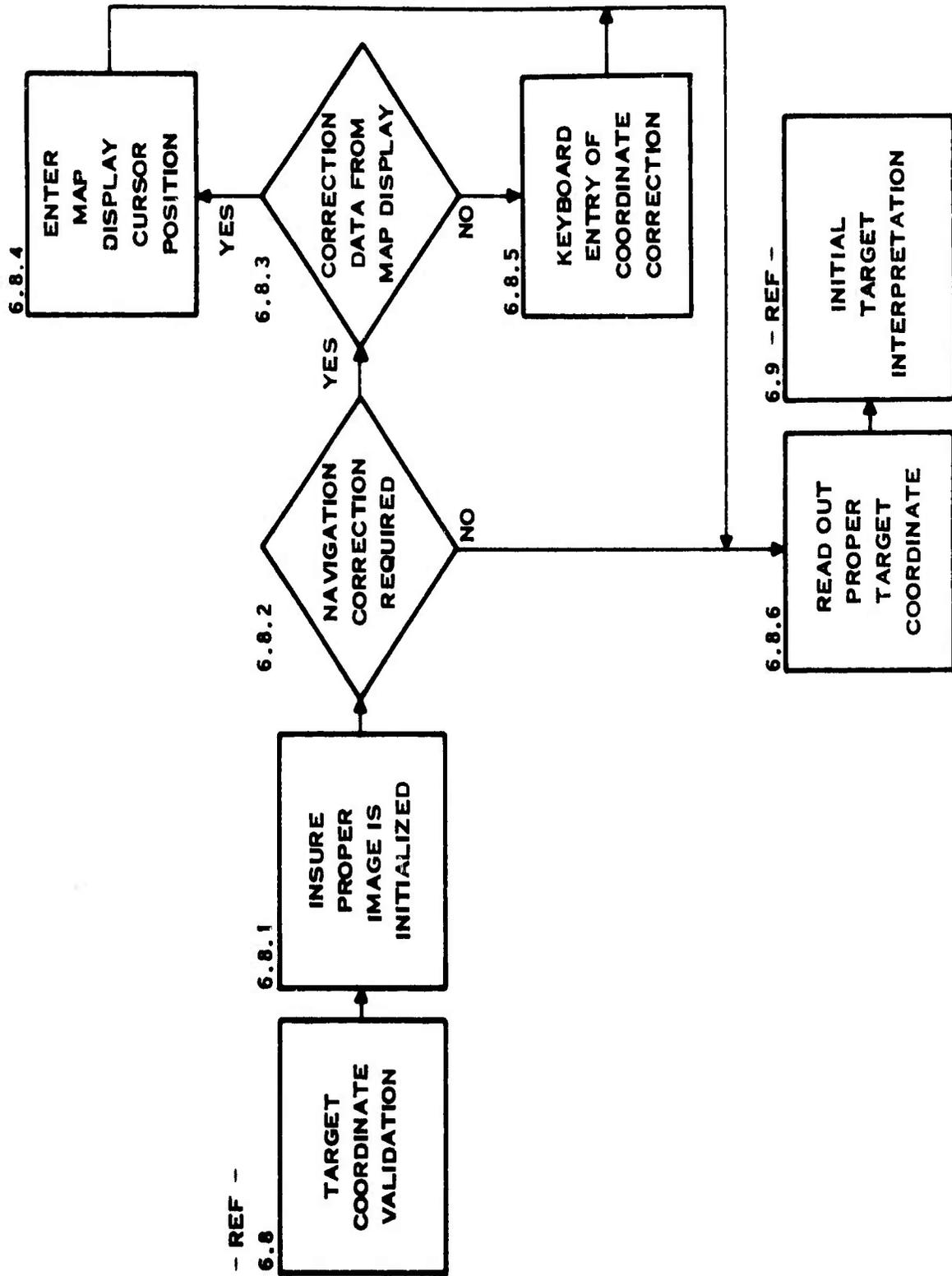

SECOND LEVEL FLOW
Figure A-5. Functional Areas of Detailed Analysis and Post Mission Update (Sheet 6 of 8)

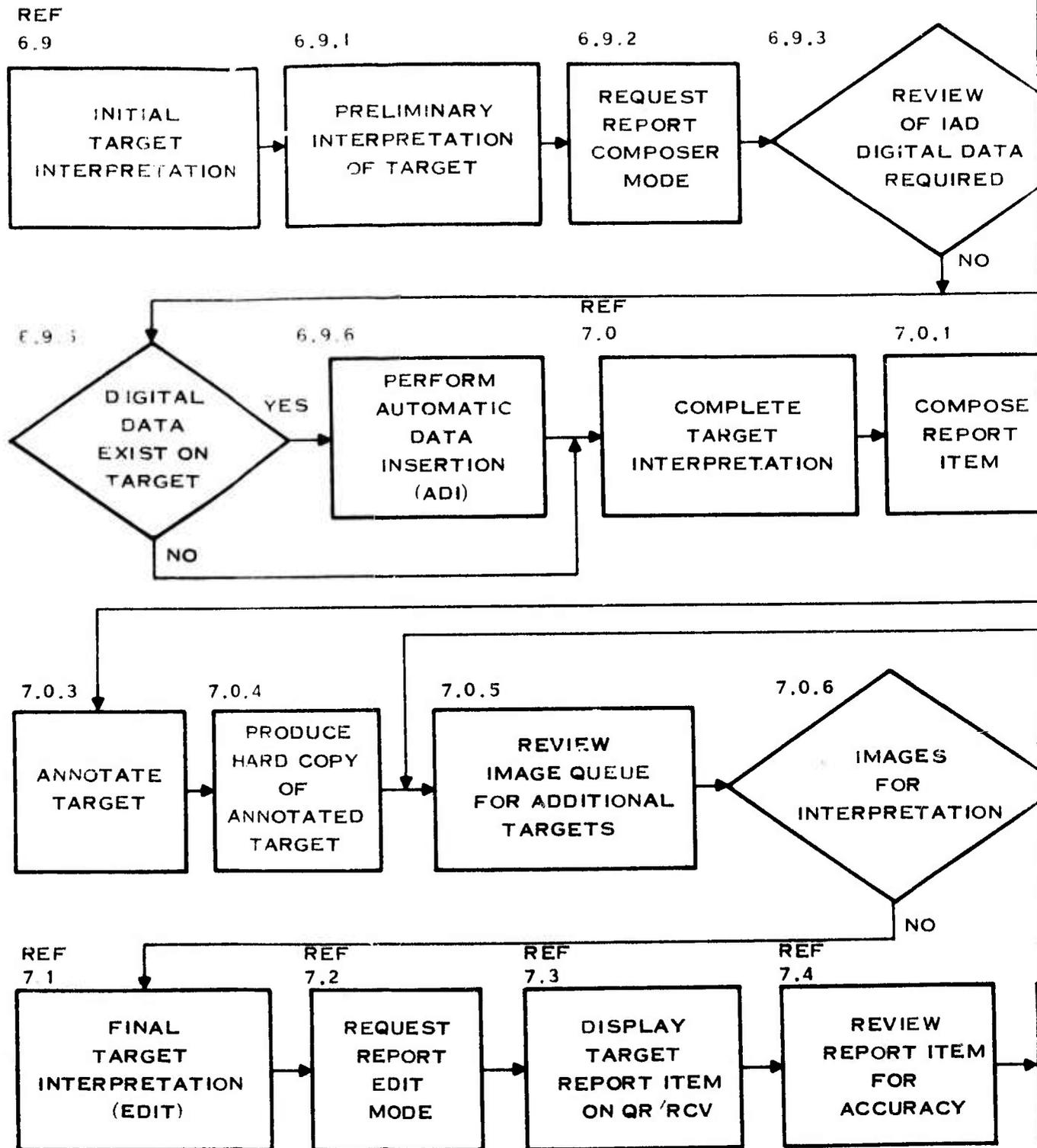

SECOND LEVEL FLOW

196410

Fig

97/

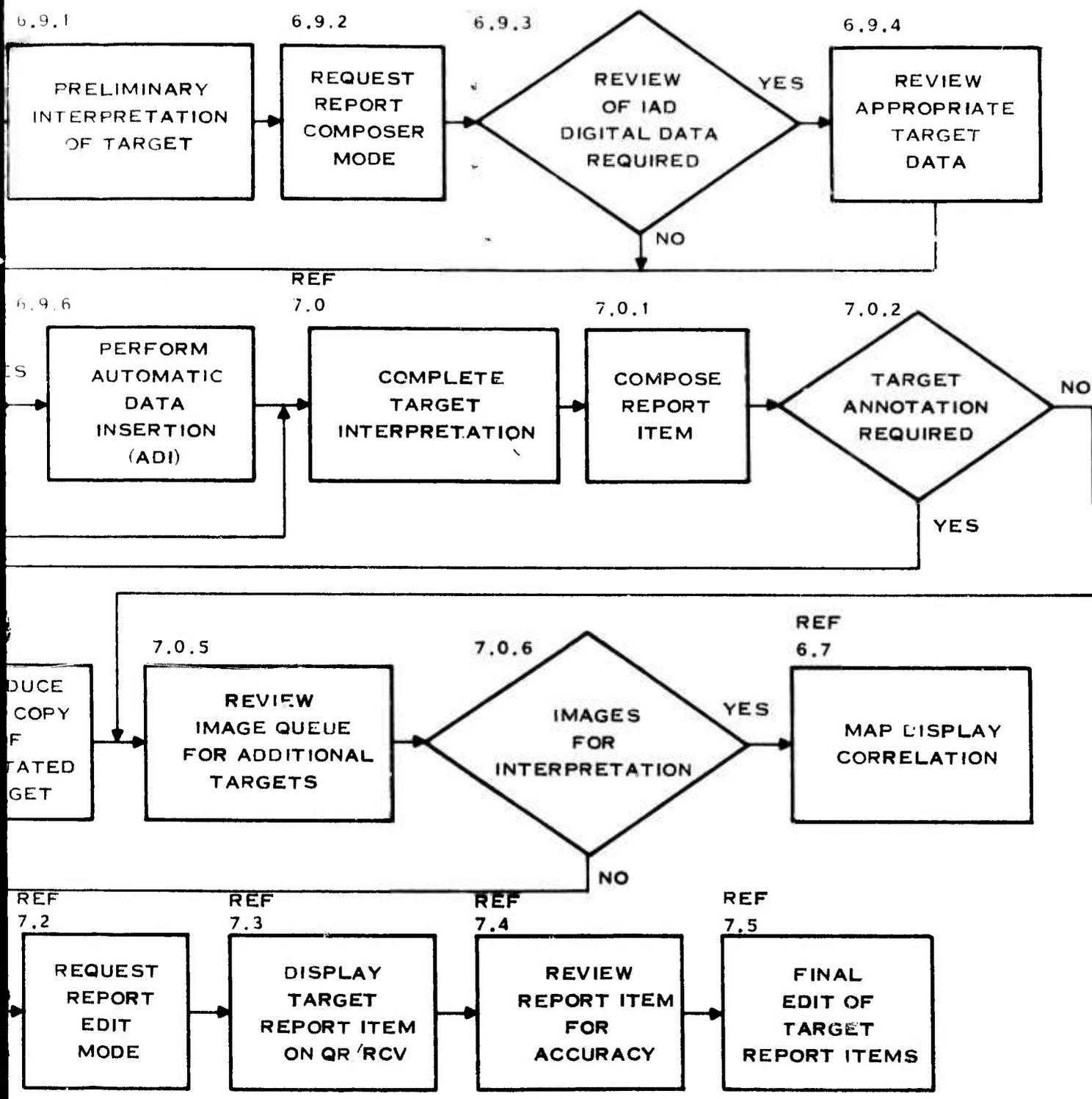

SECOND LEVEL FLOW

Figure A-5. Functional Areas of Detailed Analysis and Post Mission Update (Sheet 7 of 8)

2

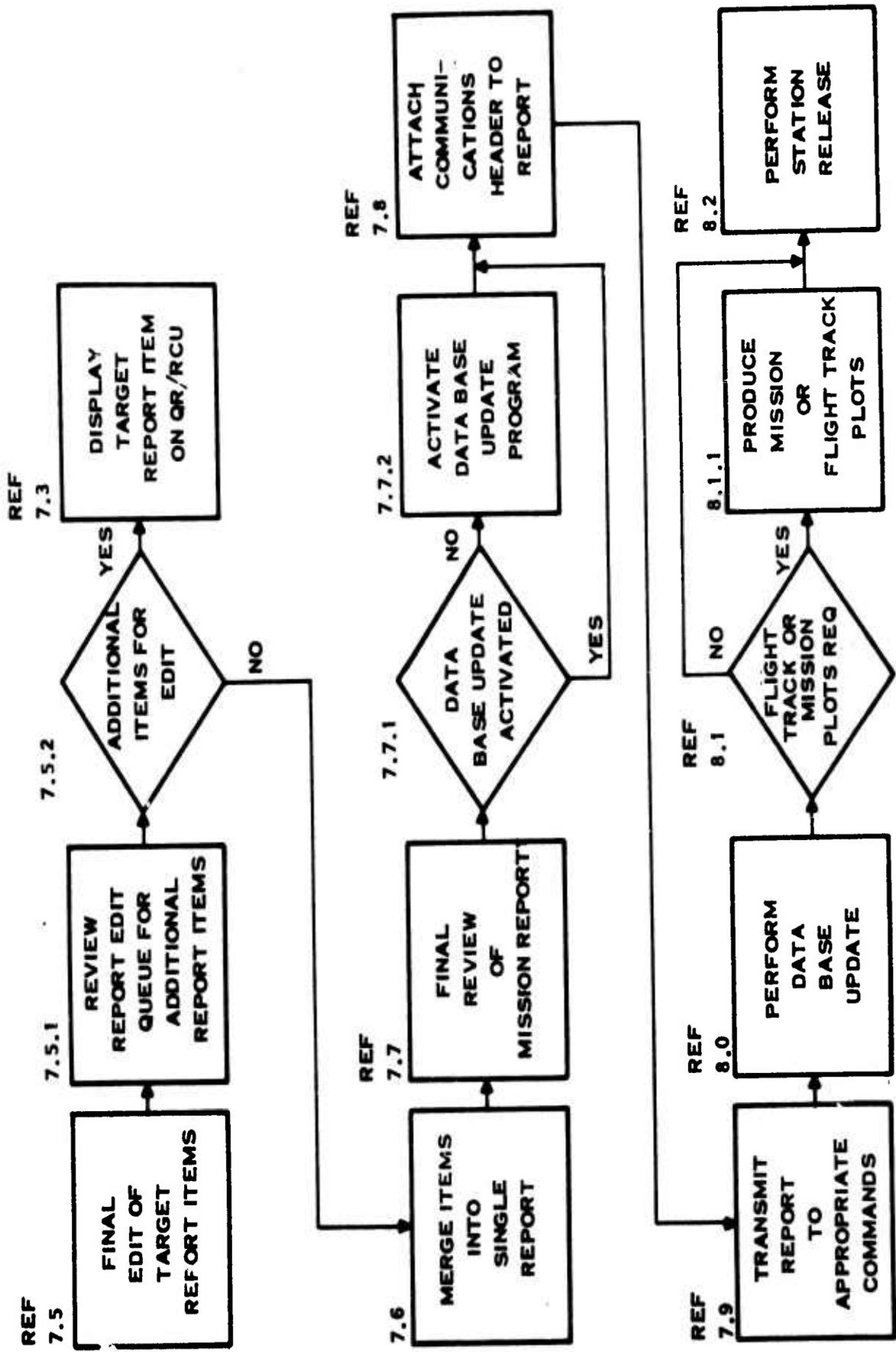

SECOND LEVEL FLOW

Figure A-5. Functional Areas of Detailed Analysis and Post Mission Update (Sheet 8 of 8)

196411

APPENDIX B
CAPABILITIES AND CHARACTERISTICS
OF RECOMMENDED II SYSTEM EQUIPMENT

This appendix provides a detailed description of the TIPI II components to be used in the RRF fabrication. The Photo Interpretation Console will not be used as such, but rather required components will be isolated from the PIC and configured in the AAD-5 detection/interpretation console.

A. DIGITAL COMPUTER (CPU)

1. Purpose of Equipment

The CP-1093 is a general-purpose, high-speed digital computer which performs the following functions:

- Serves as master controller
- Executes interpretation programs and provides interpreter with timely and accurate interpretation reports
- Provides management control and reference material support
- Provides for high-speed data transfers between the computer and the magnetic drum or between the computer and the multiplexer (XIO) buffer memory
- Provides control of secure data transfers.

2. Computer Functional Description

The computer comprises four major sections including the processor, input/output (I/O), memory and power supply (Figure B-1).

Processor—The processor section controls the instruction cycle sequences, performs all computations, services all interrupts, controls memory priority, grants memory access, and initiates all input/output transfers.

Input/Output (I/O)—The I/O serves as the interface between the computer and the external devices. This section is equipped with four parallel, bilateral data channels (expandable to eight channels), 32 discrete input lines, 48 discrete output lines, and 16 sense lines used for the transfer of data and commands. The parallel channels may be used as processor channels or direct memory access (DMA) channels under the control of an autonomous transfer controller (ATC). Once initiated, the ATC transfers a specified block of data between memory and an external device completely independent of the processor. The discrete input and output lines and the sense lines are used to control devices, monitor device inputs, and sense semistatic system functions.

Memory—The computer memory section provides a basic storage capacity of 8,192 36-bit words (plus parity) with provisions for modular expansion to a maximum of 16,384 by 36-bit words in 4,096-word modular increments. The memory is a coincident current, random access, four-wire, 3-D magnetic core unit with an access time of 800 nanoseconds, 2-microsecond cycle time. A memory cycle may be initiated by the processor, one of the ATCs, the

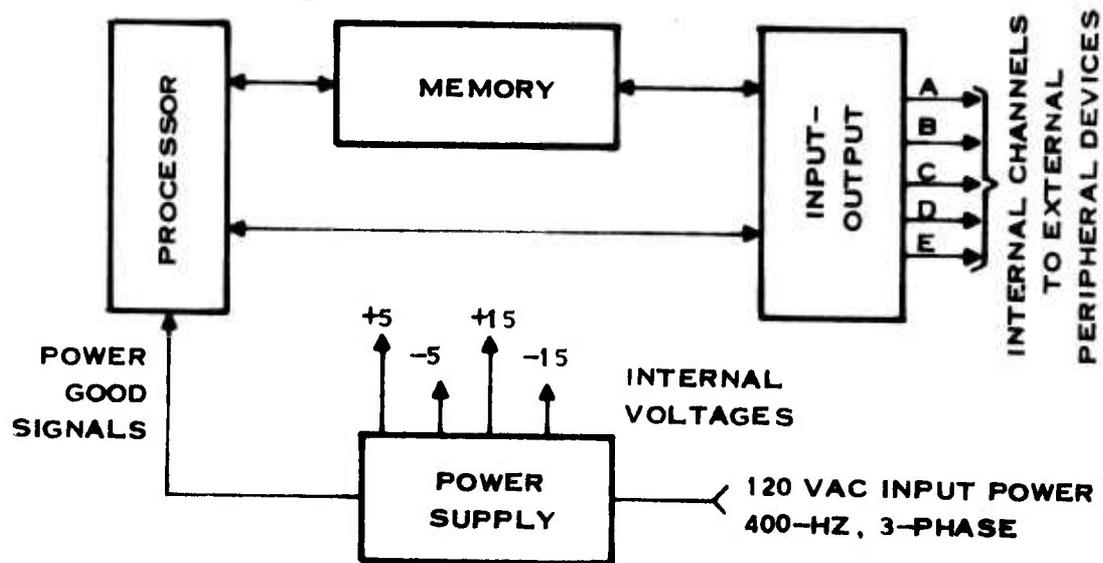

196412

Figure B-1. Computer Block Diagram

interrupt structure, or by the maintenance console according to the processor controller priority system. The memory is also equipped with a bootstrap loader which allows a core stack module (8,192 36-bit words) to be loaded from the magnetic drum.

Power Section—The power section controls the distribution of ac power and develops four regulated voltages (± 15 and ± 5 Vdc) for use throughout the computer. The power section also contains a power failure detection network which protects computer memory against power failures.

3. Instruction Set

The computer is equipped with a flexible set of 30 instructions as listed in Table B-1. In addition, each of the instructions may have up to 13 modifications as listed in Table B-2.

4. Leading Particulars

Table B-3 contains a listing of leading particulars for the CP-1093 digital computer.

5. Physical Description of Assemblies and Subassemblies

The computer (with expanded memory) comprises a total of 25 multilayer logic boards, four 8K memory core stacks, a blower fan motor, and an EMI filter assembly. Each of the logic boards is 11.6 inches by 6.0 inches in size and is equipped with ejector-insertion assists. The

TABLE B-1. INSTRUCTION SET

Instruction Type	Mnemonic	Instruction Type	Mnemonic
Add half	AH	Store half	STH
Branch and stop	BAS	Branch and link to memory	BLM
Branch on condition	BC	Add to memory half	AMH
Compare half	CH	Load status word	LSW
Load half	LH	Multiply half	MH
Load one's complement	LOCH	Exchange status word	XSW
Load two's complement	LTCH	Divide half	DH
Or half	OH	Add double half	ADH
Subtract half	SH	Subtract double half	SDH
Increment by one and branch if negative	IOBN	Load	L
Increment by two and branch if negative	ITBN	Store	ST
Register input command	RIC	Load multiple	LM
Register output command	ROC	Store multiple	STM
Shift	SFT	Move memory up	MVU
		Move memory down	MVD

TABLE B-2. INSTRUCTION MODIFICATIONS

M-Field Binary Code	A-Field Interpretation	A-Field Modification
0000	Immediate	No modification
0001	Immediate	Indexed
0010	Immediate	Mask, clear
0011	Immediate	Mask, save
0100	Register	No modification
0101	Indirect	Indexed
0110	Register	Mask, clear
0111	Register	Mask, save
1000	Direct	No modification
1001	Direct	Indexed
1010	Direct	Mask, clear
1011	Direct	Mask, save
1100	Indirect	No modification

TABLE B-3. LEADING PARTICULARS

Third-generation computer

Eight 16-bit general register file

Flexible set of 30 instructions; up to 13 modifications per instruction

Memory core storage: 16,384 by 36-bit (including parity for each 16 bits)

Core memory cycle time: 2.0 microseconds

Memory access time: 800 nanoseconds maximum

Clock rate: 2 MHz

Logic voltage levels:	Input	Output
	Logic 1: +2.1 V to +5.0 V	+2.3 V to +5.0 V
	Logic 0: 0.0 V to +0.7 V	0.0 V to +0.5 V

Signal rise and fall times: 200 nanoseconds maximum

- Input/output structure:**
- Four parallel, bilateral 17-bit data channels
 - Two autonomous transfer controllers
 - 48 discrete output lines
 - 32 discrete input lines
 - 16 sense input lines
 - 24 priority interrupt lines
 - One interval timer
 - One bootstrap loader

- Interrupt structure:**
- 24 interrupts with fixed priority
 - Mask register for arming or disarming selected interrupts
 - Selective reset capability

Processor fault conditions incorporated in interrupt structure:

- Arithmetic overflow
- Divide fault
- Double length fault
- Power failure
- Memory parity error

power supply modules are separate plug-in modules containing captive mounting screws for removal ease. The memory core stacks are mounted two stacks per plate near the top of the computer. The EMI assembly plugs into the lower right section of the back panel and is also equipped with captive screws which remain with the assembly when the filter is removed from the computer.

6. Operating Controls and Indicators

The computer front panel is equipped with the following controls and indicators:

- Power switch
- Power indication light
- Elapsed time meter
- Drum load switch.

The CP-1093 is 15.25 inches high, 15.70 inches wide, 25.90 inches deep and weighs 111 pounds.

B. QUERY RESPONSE/REPORT COMPOSER UNIT (QR/RCU)

1. Description of Equipment

The QR/RCU is a keyboard input, visual display output device, consisting of an electronics unit, a keyboard, and a monitor. An operator is provided with a two-way communication system with a central computer. The operator may compose up to 2,000 characters displayed as 25 lines of 80 characters. The message may consist of any 64 letters, numbers, and symbols. Message composition is aided by a blinking cursor underlining a character position which indicates where the next character entered will be displayed. The QR/RCU consists of monitor, keyboard, and an electronics unit.

2. Overall Operation

The overall operation sequence consists of message composition by the operator, editing or correction of the message by the operator, transmission of the message to the computer, and receipt of a response or an acknowledging message from the computer. In normal message transmission and reception sequence, the characters displayed on the display unit are sent to the computer and the characters of the answer are returned and displayed. The transmission of characters, however, is not destructive to the display. The computer may also respond with a message that will provide a message format for the operator. The type of message may be in tabular form or in a form with blank spaces for answers or variable data. In this case the operator needs only to fill in variable data fields instead of recomposing standard portions of the message for similar types of messages. When operating with the message format, certain operations will be performed differently than when a message format is used.

3. Physical and Electrical Characteristics

Operational Characteristics

Number of lines	25
Characters per line	80

Character type	7 X 10 dot matrix
Character repertoire	64 USASCII alphanumeric
Character storage	2,000 characters
Display size	14 inch
Display format	EIA-RS170/RS3300 TV
CRT Phosphor	P39
Character size	0.120 by 0.080

Cursor and Edit Features

Cursor type Nondestructive underline
(flashing when idle)

Cursor movements

Return down—Single or repeat
Space—Single or repeat
Backspace—Single or repeat
Return up—Single or repeat
Reset cursor—Cursor home

Edit features

Character erase—Single or repeat
Line erase—Single or repeat
Character delete—Closes up space
Insert mode—Including character erase
Program select—Dual mode 32 lighted keys (64 selections)

Special Features

Reserved display areas—Format fields
Write buffer—Start line/number of lines
Read buffer—Start line/number of lines
Transmit—Complete page
Write cursor—Line and character position
Read cursor—Line and character position

Physical Characteristics

Keyboard, Modular Construction

Size—16 inches wide by 8 inches deep by 5 inches high
Tactile feedback on keys
Reed switches
32 lighted program select keys

Functional grouping

Sloped key panel

Weight—approximately 15 pounds

Electronic Unit, Modular Printed Circuit Board Construction

Size—19 inches wide by 7 inches deep by 10.5 inches high

Standard rack mount with handles

Self-contained blower

Elapsed time indicator

Weight—35 pounds

Monitor, Modular Construction

Size—14.5 inches wide by 16.25 inches deep by 12.25 inches high

Self-contained blower

Front brightness and contrast controls

Front and side handles

Triax video connector

Weight—40 pounds

Electrical Characteristics

Keyboard

Functional "N" key rollover

Immune to contact bounce

USASCII code

64 program select codes. 32 dual mode keys

63 characters plus space bar

Shift lock

2 shift keys both unlock shift lock

4 clustered edit keys

1 transmit key

Power supplied from electronic unit

Electronic Unit

All solid-state integrated-circuit logic

Static MOS 2000 character storage

MOS 7 X 10 dot matrix character generator

Format bit storage for reserved areas

TTL logic levels at interface

Separate input and output data lines

500 kHz character transfer rate

Interrupt signal for program keys
Internal 3-phase, 400-Hz power supplies
Input power 400 watts—meets MIL-STD-704A
Fully synchronous logic design

Monitor

EIA RS170/RS330 525-line TV
Composite video input
Solid-state JAN TX semiconductors
12-MHz video bandwidth
EMI coated CRT
P39-14 inch CRT
Front panel brightness control
Front panel contrast control
Maintenance controls under front cover

Other Characteristics

MTBF	5,000 hours
MTRR	30 minutes
Maximum repair time	1 hour for 95 percent of maintenance
Storage temperatures	-55° to +125°C
Operating	0° to +55°C
Humidity (nonoperating)	95 (+5, -0) percent at 70°C
Vibration (nonoperating)	MIL-STD-810B -2 to 55 Hz curve W 55 to 500 Hz curve V
Shock	30 g for 18 milliseconds MIL-STD-810B Method 516.1 Proc. 1
Salt fog	MIL-STD-810B Method 509 Proc. 1
Sand and dust	MIL-STD-810B Method 510 Proc. 1
Fungus resistance	MIL-STD-810B Method 508 Proc. 1
Materials per MIL-E-4158	
Parts per MIL-E-16400	

EMI per MIL-STD-161
Class IC

Human engineering per
MIL-STD-1472

C. DATA STORAGE MAGNETIC DRUM

1. Physical Description

The II Data Storage Magnetic Drum System consists of the drum unit, head selection and read/write electronics, interface electronics, power supply drawer unit, and interconnecting cabling. The drum is an interchangeable, compact, cylindrical unit. Its critical parts, such as the read/write heads and motor, are in a metal casing, which has been purged with dry nitrogen and sealed for stability. The drum is mounted toward the front of the memory drum assembly with the end of the drum motor housing directly behind the front panel. The input power connector, drum pressurizing valve and drum elapsed time indicator are mounted on the housing. Handles provided on the drum facilitates lifting the system package.

The memory electronics assembly is located behind the drum, to the rear of the memory drum assembly. This assembly contains a row of vertically-mounted, plug-in circuit cards. The cards containing the drum electronics timing circuits are located at one end of the assembly; the other drum electronics cards are mounted toward the center. The interface electronics cards are mounted at the other end of the assembly. Effective use of modular packaging provides compactness and facilitates maintenance.

The power supply is located next to the end of the drum motor housing directly behind the front panel of the memory drum assembly. The front panel contains indicators for power, low drum pressure and system elapsed time. It is provided with two handles to facilitate handling of the memory drum assembly when mounted in a standard RETMA cabinet.

The complete memory drum assembly weighing 89 pounds is secured to a slide-mounted chassis which is inserted in a standard RETMA cabinet. The chassis dimensions are 17 inches wide, 23 inches deep (including connectors), and 10.30 inches high. The standard 19-inch front panel is 10.5 inches high.

For proper operating efficiency, the memory drum assembly is provided with forced air cooling. Air is drawn through a louvered opening on the front panel for cooling the electronics components. The air is drawn through the memory drum assembly by a Rotron fan operating at 3300 rpm nominal. Cooling air drawn through the assembly passes through the plenums of the memory electronics assembly, past the circuit cards, and out the exhaust at the rear of the assembly.

EMI filters are located in the input power lines. In addition, all interconnecting cables are properly shielded and grounded to a common chassis ground point to minimize interference. There are EMI filters on all inputs and outputs to the power supply and on all dc inputs to the electronics assembly.

The equipment is designed to operate from a 3-phase, 400 Hz power source providing 120 volts line-to-neutral and 208 volts line-to-line. The maximum average power supplied is 300 watts; the maximum peak power (for start-up) is 1,500 watts.

2. Basic operation

The magnetic drum is an aluminum cylinder plated with a thin, uniform metallic plating which serves as the magnetic recording media. The drum is rotated at a constant speed.

In the write operation, as the drum rotates, small areas (or cells) on the drum's surface become magnetized in accordance with the bit pattern of the data being written into the drum. Magnetic poles are created in cells that are to contain logic 1's; they are omitted from cells that are to contain logic 0's.

In the read operation, as the drum rotates, the magnetic flux associated with each pole induces a voltage, or data signal, in the coil of the read/write head passing through the magnetic field. The induced data signal is amplified and shaped to provide a square-wave voltage designating logic 1. The absence of a magnetic pole, which is indicated by an excursion of this output square-wave voltage, signifies that a logic 0 is being read.

Bit cells are arranged in circumferential bands, or tracks, on the drum's surface. Each track contains many words recorded consecutively. Tracks are addressed in accordance with an established selection format. The location of an individual memory cell involves designating the track in which the cell is located and the angular position that the drum will assume when the cell is available. The angular position is identified by timing pulses that are synchronized with the rotation of the drum. The pulses are generated by a special timing, or clock track on the drum. They are distinguished from one another by the use of another special track—the sector track. Information representing the actual angular position of the drum is stored on the sector track and is used to identify sector locations on the addressed track.

3. System Characteristics

The major functional characters of the TIPI II Data Storage Magnetic Drum System are listed in Table B-4. The drum system has storage capacity for 860,160 words of 17 bits each. This enables the storage of 16-bit words with parity. A total of 16 stored words is contained in a sector as indicated in Figure B-2.

Defined as a head-per-track system, the memory contains 260 data read/write heads and physical data tracks (including 4 spare tracks). However, there are 768 addressable tracks. A physical track contains 3 addressable tracks each of which contains 70 addressable sectors (or blocks). The addressable tracks are numbered consecutively from track 0 through track 767. The sectors are numbered consecutively from sector 0 through sector 69. With this arrangement, it is possible to perform a continuous, consecutive read or write operation, from the given initial address to the end of the drum.

In addition to the 768 addressable data tracks, there are 4 timing tracks (including two spare tracks). The sector track is synchronized to the 1.25-MHz master clock, with one serial sector bit per clock period.

The heads on all tracks are described as "flying" heads. Heads (and tracks) may be effectively disconnected from the system by head selection modification.

TABLE B-4. FUNCTIONAL CHARACTERISTICS OF TIPI II DATA STORAGE MAGNETIC DRUM SYSTEM

Memory type	Random access, nonvolatile, digital mass storage memory
Master clock rate	1.25 MHz (2.5-MHz bit rate)
Bits per word	17 (including 16 data bits and 1 parity bit)
Words per block (sector)	16 (plus 16 bits for preamble and guard)
Blocks (sectors) per track	70
Words per track	1,120
Number of data tracks	768 addressable tracks, or 256 physical tracks (plus 4 spare data tracks)
Access time	28.3 milliseconds, maximum
Mode of data transfer	Serial-block transfer in read and write modes (single block alteration capability in write mode)
Data transfer rate	845,000 data bits per second, maximum 700,000 data bits per second, minimum
Address format	24X11 selection matrix; 10-bit address to designate 1 of 768 tracks; 7-bit address to designate 1 of 70 sectors

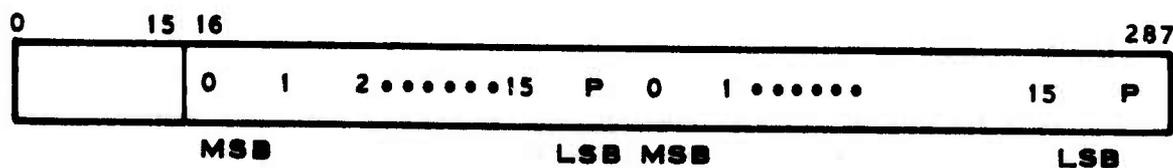

**SECTOR BITS 0-15 ARE PREAMBLE AND GUARD
SECTOR BITS 16-267 CONTAIN 16 WORDS. EACH HAVING
17 BITS (INCLUDES PARITY)**

196413

Figure B-2. Organization of a Data Sector

The access time, defined as the sum of the maximum rotational latency time and operating mode/head selection time is less than 28.3 milliseconds. At start-up, the drum attains normal operating speed within 1 minute after the application of ac power.

4. Front Panel Indicators

a. Power Indicator

This time totalizing meter is a time clock which operates from a 400-Hz, 120-volt ac power source and indicates the total accumulated power-on time experienced. The elapsed time meter is mounted on the upper right-center of the front panel.

b. Low Drum Pressure Indicator

This indicator, located on the top right of the panel, is illuminated when drum power is applied and the drum pressure is below 17 pounds per square inch absolute. When this indication is given, the drum unit should be repressurized at the earliest opportunity. Temporary operation (for a short period) when the drum pressure is low should not damage the drum unit.

D. MULTIPLEXER (XIO)

1. Description of Equipment

The XIO is an extended input/output digital unit and is used to route commands, data, and status information between digital computers and the data storage magnetic drum, and to provide signal routing and interchange between outside devices.

2. General Functional Description

Functionally, the XIO consists of a data multiplexer, drum control unit (DCU) clock, displays, and power supplies. The data multiplexer portion of the XIO consists of light independent, input/output channels (channels 0 through 7) with associated logic circuitry. Two of the channels may interface externally with computers, two channels may interface with other input/output devices, and four channels may interface internally within the XIO to device control units. The device control units, in turn, interface with corresponding ADP peripheral devices and allow the computers to communicate with the devices.

a. Data Multiplexer

The data multiplexer: (1) establishes priority for linking computer channels with the connected devices, (2) routes commands and data between the computers and the devices, and (3) provides the computers with status replies regarding execution of commands and transfer of data.

b. Drum Control Unit (DCU)

The DCU is connected to channel 2 of the data multiplexer. The DCU receives data from a computer via the data multiplexer and stores the information on the drum (write mode), or retrieves data from the drum in response to a computer command (read mode) and transfers the data to the computer.

c. Communication Interface Unit (CIU)

The CIU is separate and independent of the data multiplexer. The CIU provides computers with access to the secure communication lines (KW-7 and KG-30) for the transmission or receipt of data. The CIU receives data in parallel format from a computer, converts the data to serial format, and sends the data to the communications equipment. The CIU converts incoming serial data from the communications equipment to parallel format and sends the information to the active computer.

d. Clock and Display

The clock and display circuits generate and control the system clock and the illumination of the DATA and STATUS lamps on the XIO front panel, as selected by the DATA, STATUS, and FUNCTION switches. These displays may be used for system routines and diagnostics in a TEST mode by using the single-step clock (S/S CLOCK) switch. The DATA and STATUS lamps display the following: input and output data of the eight channels, contents of the status registers and buffer memories, and status of the controllers, counters, flags, registers, and controls of the various functional units of the XIO.

e. Power Supplies

The XIO contains three power supply modules, two "A" modules, and one "D" module. These supplies provide regulated ± 5 Vdc and ± 12 Vdc for distribution and use in the various functional areas of the XIO.

f. Magnetic Tape Control Unit (MTCU)

The magnetic tape control unit (MTCU) is connected to channel 5 of the data multiplexer. The MTCU allows a computer to operate the magnetic tape transports (MTTs) and to record (write) information on the magnetic tape, or to retrieve (read) information previously recorded on the tape. The MTCU is also capable of directing a channel independent operation (CIO) which enables an MTT to perform independent operations, even though it is not linked to a computer during the CIO. Status information from an MTT is transferred directly to a computer, or indirectly to the computer through a buffer memory in the data multiplexer.

3. Leading Particulars

Physical Characteristics

Case: 17 inches wide by 10 inches high by 26 inches deep

Front Panel: 19 inches wide by 10.5 inches high; 98 pounds

Electrical Characteristics

Input Power	120-volt, 400-Hz, 3-phase, 4-wire
Power Consumption	300 watts
Internal Power	+5 Vdc at 30 A +5 Vdc at 35 A -5 Vdc

Signal Characteristics

Logic 1 (high)	+2.1 to +5.0 volts
Logic 0 (low)	0.0 to 0.7 volt
Rise and fall time	200 ns
Data word length	17 bits (16 data and 1 parity)
Clock rate	2 MHz

4. Assemblies and Subassemblies

EMI filter	Provides electromagnetic filtering for input power
Blower fan	Provides cooling air
"D" module supply	Generates +263 Vdc for use by "A" modules; generates regulated -5 Vdc for use in XIO
"A" module supplies	Generates regulated +5 Vdc for use in XIO
DCUC board	DCU controllers
DCURB board	Registers and buffers for DCU
PRSS board	Set data multiplexer status registers for link, unlink, power failure, and signoff commands
MCAL board	Link command priority for 8 channels
MXCC board	Channel controllers for 8 channels
UNBS board	Unlink control and bit slice
CDLB board	Channels 0 through 2 command decode and priority for loading all channels
MMCD board	Channels 3 through 7 command decode
MXBX board	Data select (bit slice) for 8 channels
MLDR board	Line drivers and receivers for external channels
MDB board	Data buffers
Clock and Display board	Clock generator and control for front panel indicators
Front panel	Controls and indicators
CIU-1 board	Modem and TTY controllers, registers, flags and counters
CIU-2 board	Modem buffers and counters, registers

MTCU-1 board	EOR, EOF, and EOT controllers and associated circuits
MTCU-2 board	Read, write and MTT initialization controllers and associated circuits
MTCU-3 board	CIO and search controllers
MTCU-4 board	MTCU initialization, data-in, and data-out, controllers
MTCU-5 board	Registers, flags, and channel 5 output data

E. PRINTER

1. Description of Equipment

The printer receives binary-coded data from the XIO-2 multiplexer and translates this information into the hard copy, using thermal printing heads. Its primary purpose is to produce hard copy page output for imagery interpretation reports, hard copy index, operational data, and work order data.

2. System Functional Description

The XIO-2 multiplexer receives binary-coded data from the CP-1093/TYQ digital computer, routes the data via the controller printer-punch-reader control unit, and finally sends the data to the printer for hard copy printout.

3. Printer Functional Description

The printer circuitry (Figure B-3) is divided into 10 functional areas. The following paragraphs provide a brief description of each operational area.

a. Control Panel

The control panel contains the only operator controls for the printer. These are namely paper step and paper slew, paper torn and paper low, on-line and off-line, a contrast control knob, and an elapsed time indicator.

b. Control Logic

The control logic circuitry controls all internal signals and all those response signals sent to the XIO-2 multiplexer from the printer. The control logic circuitry interfaces directly with character generator circuits, head buffers/drivers, the motor driver circuit, and the control panel.

c. Input/Output Logic

The I/O logic accepts all input command and data signals received from the XIO-2 multiplexer. The logic also controls all output signals to the XIO-2. The I/O logic interfaces directly with the control logic, character generator, and memory.

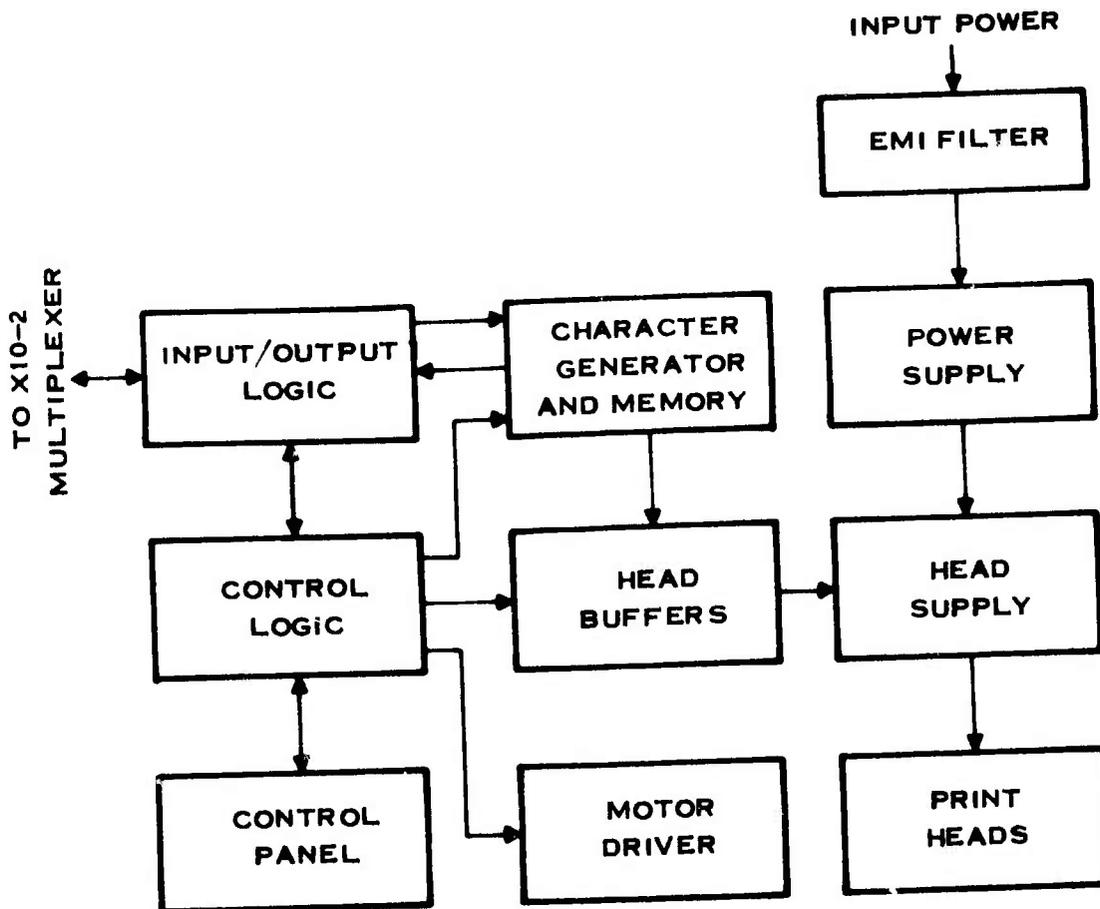

196414

Figure B-3. Printer Simplified Block Diagram

d. Motor Driver

The primary function of the motor driver is to accept commands from the control logic and drive the stepper motor accordingly. The circuit board has three additional circuits. The light sensor feeds a comparator that detects when a top-of-page condition exists. The top-of-page detection is used by the paper advance control logic. An overvoltage detector and combiner determines if the +30-volt supply is operating within normal acceptable tolerances. When an abnormal voltage is detected, the print cycle is terminated. A validity detector monitors the input for invalid or illegal characters. When either is detected the on-line functions are terminated.

e. Head Buffers

The head buffers are essentially 40-bit serial-in/parallel-out shift registers. Each of the five character generator outputs is clocked into two serially connected head buffer boards to allow storage of one row of dots for all 80 characters. All the register outputs feed head driver transistors which activate the appropriate dots in the heads. This process is repeated seven times for the complete 80 character lines of information.

f. Character Generator and Memory

The memory portion stores character data received from the XIO-2. The character generator portion decodes the character data and encodes the data into suitable buffers for the thermal printout.

g. Print Heads

The printing mesas in thermal print heads are activated in the appropriate sequence to form characters on the heat-sensitive paper.

h. Head Supply

The head supply supplies regulated power to all 16 print heads in the printer when a print command is received from the control logic.

i. Power Supply

The power supply generates the +5-volt regulated outputs used in the logic circuits. The regulator board generates the +10-volt, -18-volt, -5-volt, -2-volt, and the reference voltage for the head supply.

j. EMI Filter

The EMI filter assembly prevents RF energy from leaving the printer by way of the power lines. It is a sealed nonrepairable unit approximately 5.5 by 6.0 by 3.0 inches.

k. Crowbar Overvoltage Network

This network is located on the crowbar module and provides primary protection against overvoltage conditions from the +5-, +10-, and -18-volt power supplies.

4. Physical Description

a. Leading Particulars

Table B-5 contains a list of leading particulars for the printer.

TABLE B-5. PRINTER LEADING PARTICULARS

Characteristic	Specification
Inputs	
Data	ASCII-coded data on seven parallel lines
Character strobe	Control signal; printer stores data character when high
Print command	Control signal; causes stored characters from buffer to be printed when high
Buffer clear	Control signal; printer clears the character counter
Line advance	Control signal; causes printer to initiate a single line advance of the paper
Top-of-page command	Control signal; causes printer to advance paper to top-of-page reference point
Outputs	
Ready	Control signal; when low, indicates that printer is ready to accept data or commands
Printer-on-line	Control signal; when high, indicates that printer is ready for on-line operation
Printer connected	Control signal; low signal indicating that printer is physically connected to power source
Character storage	80-character line
Printing speed	325 lines per minute
Printed lines (per 7-inch sheet)	42 lines
Character form factors	
Height-to-width ratio	Between 5.5:4 and 6.5:4
Stroke width-to-height ratio	1:6
Width	0.070 inch
Spacing	0.020 inch
Height	0.110 inch
Line spacing	0.057 inch
Character repertoire	64 ASCII characters
Paper type	Prepunched, 9½ inches wide, 7 inches fanfold with 8½ inches width for printing
Paper handling	Sprocket feed
Copy output	Single copy
Paper speed	
One line advance	<150 milliseconds
Slew rate	3½ inches per second
Power requirements	
Primary power	120 volts (LN) 208 volts (LL) 3-phase, four-wire, connected-wye, 400-Hz
Maximum power	<450 watts
Maximum peak power	2,000 watts
Weight	<115 pounds
Height	19.22 inches
Width	19.02 inches
Depth	23.0 inches
Construction	Modular (removable PWBs)

TABLE B-5. PRINTER LEADING PARTICULARS (Continued)

Characteristic	Specification
Environmental limits	
Operating temperature range	+50° to +105°F
Nonoperating temperature range	-65° to +160°F
Relative Humidity	15 to 97 percent

b. Special Features

In addition to the characteristics described in Table B-5, the printer has the following protective features:

High and low temperature protection is provided for temperatures out of the normal printer operating temperature range.

The power supplies use overvoltage and overcurrent protection.

The print heads are equipped with a protector to prevent damage to the head while loading or unloading paper.

A contrast control is provided on the front panel to allow for variations in paper uniformity.

A torn paper sensor dynamically monitors the paper drive and places the printer off-line when a tear is detected. This condition is indicated by a lamp on the printer front panel.

The printer has an automatic form factor which allows a 0.2-inch margin to be created at the top and bottom of each page.

F. MODULAR MAGNETIC TAPE TRANSPORT (MMTT)

1. Description

The magnetic tape units provide a compact, highly reliable device for recording and retrieving digital information on magnetic tape.

Features of the MMTT include its own self-contained control electronics; read, write, erase, and deskewing electronics; transport deck, drive motors; motor servos; and internal power supplies. A single-capstan, vacuum-column drive and a controlled start/stop technique provide for gentle handling of the tape, enabling more than 100,000 passes over the read/write head without permanent tape damage. Other features include quick-release hubs which receive standard 8- or 10.5-inch reels, subminiature parts, linear and digital integrated circuits, and unique design and packaging of servo and power supply circuits.

The MMTT is slide-mounted for installation in a cabinet.

A time-totalizing meter is positioned on the operator panel to record time, in hours, that prime power has been applied to the MMTT.

A mechanical interlock switch is installed directly on the MMTT deck. The interlock switch is spring loaded and is actuated by the reel access cover. When the cover is open and power is on, the switch contacts are closed and a ground is applied to the fault-sensing circuits, inhibiting all drive to the reel motors. The interlock switch can be set manually to allow normal operation with the reel access cover open should this be necessary for certain applications or for troubleshooting purposes. When the switch has been set manually, closing the reel access cover releases the switch from this position so that when the cover is again opened, the switch will actuate automatically.

All other controls and indicators for operating the MMTT are installed on the operator panel (OP) mounted on the front panel of the MMTT chassis.

The MMTT is compatible with standard, industry accepted tape systems. It uses 0.5-inch, A-wound (oxide coating on the under side), polyester-base tape. It performs 9 channel forward recording and forward/reverse reading at a density of 800 bits per inch. Recorded digital information has a normal interblock gap of 0.6 inch and a 3.75-inch extended interblock gap. Normal operating speed is 75 inches per second in either the forward or reverse direction. A fast rewind feature enables tape to be slewed in reverse at 150 inches per second with an automatic stop at load point [beginning of tape (BOT) marker].

2. Physical Characteristics

Weight	155 pounds
Panel Width	9.45 inches
Panel Height	27.97 inches
Chassis Width	9.12 inches
Chassis Height	24.50 inches
Chassis Depth	26.00 inches
Calculated mean-time-between-failures	2,000 hours
Calculated mean-time-to-repair	45 minutes
Reel size	8 or 10.5 inches
Head Life	2,000-hour tape motion time minute
Magnetic tape:	
Type	A-wound (oxide coating on under side of tape), polyester base, 1.5 mil
Width	0.5 inch
Operating position	0.5 inch
Single-capstan, vacuum-column drive	
Industry-compatible reels and hubs	

Quick-release, low-profile reel locks

Self-contained power supply

Cooling:

Printed circuit cards

Conductive

Other Components

Direct airflow

3. Functional Characteristics

Read/write speed	75 ips \pm 3 percent
Rewind speed	150 ips minimum (2,400 ft in 3.5 minutes)
Start/stop distance	0.215 \pm 0.005 inch
Start/stop time	5.5 ms
Recording characteristics	
Channels	9
Density	800 bpi
Interblock gap	
Normal	0.6 inch
Extended	3.75 inches
File protection functions:	Removable ring
Read/search	Forward or reverse
Space file	Forward or reverse
Write	Forward
Rewind	To load point (Bot)
Solar cell sensor circuits:	
Beginning and end of tape	BOT and EOT reflective markers
Tape position control	Tape position in vacuum column
Tape speed control	Roller-tachometer
Tape life	More than 100,000 passes
Error rate	Less than one nonrecoverable error in 10 ⁷ bits

Total dynamic skew when reading 1's from all sources (dissymmetry, pulse crowding, dynamic skew, etc.)	3.5 μ s maximum
Prime input power	208-volt, 3-phase, 400-Hz, wye-connected, 900-watt peak, 600-watt average
Internal power requirements (provided by self-contained power supply):	
+5 V regulated	Used for logic circuits, line drivers, line receivers, and dc erase current
+12 V regulated	Used for linear operational amplifiers, write voltage, manual control panel indicators, and miscellaneous bias and voltage circuits
-12 V regulated	Used for linear operational amplifiers, line receivers, and miscellaneous bias and voltage circuits
+24 V unregulated	Used to drive capstan motor in forward direction (ccw)
-24 V unregulated	Used to drive capstan motor in reverse direction (cw)
+31.5 V unregulated	Used for supply reel drive
+31.5 V unregulated	Used for takeup reel drive
+6 V unregulated	Used for reel drive transistor bias; referenced to the unregulated +31.5 V, making total of +34.5 V
208 V, 3-phase, 400 Hz, unregulated	Blower power
390-mA regulated constant current supply	Used to illuminate tape sensor lamps
Operating altitude:	Up to 10,000 feet
Warmup time (from point of equipment turnon; assumes use of external heaters	

on at time of
equipment turnon,
and relative humidity
up to 95 percent):

0° to 55°C	Within 0.5 minutes
-25° to 0°C	Within 5 minutes
-54° to -25°C	Within 20 minutes

G. ELECTROSTATIC MAPBOARD

1. Purpose of Equipment

The map display consists of the mapboard and map cursor. The mapboard is used to mount maps and the map cursor provides a means to enter positional data from the map into the digital computer.

2. Physical and Electrical Characteristics

Weight	76 pounds
Height	3 feet
Width	3 feet
Depth	6 inches
Map Cursor	
Type	Crossed wire
Travel area	30 by 30 inches
Speed	0 to 3 inches per second, operator controlled
	Slow speed, computer controlled, 0.6 inch per second minimum
	Fast speed, computer controlled, 3 inches per second minimum
Accuracy	±0.01 inch or 0.2 percent, whichever is greater.

H. PHOTOINTERPRETATION CONSOLE (PIC)

1. Description

The PIC is used to support and assist the photointerpreter (PI), by mechanization and automation, to carry out the following operations.

View film transparencies, maps, and overlays

Communicate with the central processing unit (CPU/digital computer).

The PIC is designed to automate and/or optimize all possible functions required to extract intelligence data from reconnaissance imagery. The PIC consists of a film transport, direct-view display, stereo zoom microscope and a map display. It also provides electrical and mechanical interface for the code matrix reader and the indicator control group, OD-61. The film transport consists of two independent film tracks which transport film in the console to the direct-view display and code matrix reader. The direct view display consists of a main viewing surface, a stereo viewing surface, a film slack-loop assembly, and a film cursor. The viewing surfaces are backlighted diffused glass and provide a background for viewing imagery. The slack-loop assembly is used with the stereo zoom microscope to provide stereo viewing capability. The film cursor consists of a movable optical assembly located under the main viewing surface. The cursor is projected onto the viewing surface and provides a means to enter positional data into the digital computer. The map display consists of the mapboard and map cursor. The mapboard is used to mount maps and the map cursor provides a means to enter positional data from the map into the digital computer (CPU).

2. Physical and Electrical Characteristics

Characteristic	Specification
Stereo zoom microscope	
Magnification	3.5X to 60X monocular 3X to 60X stereo
Resolution	180 line pairs per millimeter on axis at 30X
Image rotation	±180 degrees continuously variable
Mapboard	
Weight	76 pounds
Height	3 feet
Width	3 feet
Depth	6 inches
Type	Electrostatic
Map cursor	
Type	Crossed wire
Travel area	30 by 30 inches
Speed	0 to 3 inches per second, operator controlled Slow speed, computer controlled, 0.6 inch per second minimum Fast speed, computer controlled, 3 inches per second minimum
Accuracy	±0.01 inch or 0.2 percent, whichever is greater
Console	
Weight (excluding QR/RCU, CMR and associated cables)	1,560 pounds
Height	76 inches
Width	87 inches
Depth	35 inches
Power consumption (excluding QR/RCU and CMR)	4,150 volt/amperes maximum
Voltage requirement	120 ±6 volt ac, 400-Hz, 3-phase, 4-wire line to neutral

Characteristic	Specification
Film transports	
Film capability (color or black and white)	70-mm, two rolls side-by-side, 10½-inch diameter spool 5-inch, two rolls side-by-side, 10½-inch diameter spool 70-mm and 5-inch side-by-side, 10½-inch diameter spools
Film thickness	0.0025 to 0.012 inch
Film speed	0 to 40 inches per second, operator controlled Slow speed computer-controlled, adjustable from 2 to 4 inches per second Fast speed computer-controlled, adjustable from 4 to 40 inches per second
Film acceleration	Maximum of 100 inches per second squared
Direct view display	
Main viewing surface area	12 by 32 inches
Illumination	>2,000 footlamberts at maximum brightness with 10:1 dimming range
Stereo view surface area	4.5 by 12 inches
Illumination	>2,000 footlamberts at maximum brightness with 10:1 dimming range
Slack loop	Collects up to 95 inches of film
Film cursor type	Projected reticle
Film cursor travel area	11 by 30 inches
Film cursor speed	0 to 2.5 inches per second, operator controlled Slow speed computer-controlled, 0.3 inch per second minimum Fast speed computer-controlled, 2.5 inches per second minimum
Film cursor accuracy	±0.004 inch or ±0.2 percent, whichever is greater

I. CODE MATRIX READER (CMR)

1. Description of Equipment

The CMR is an automated system that senses the density variations in a MIL-STD-782C code matrix block as annotated on reconnaissance file. The information in the code block is translated into excess-three binary coded decimal (+3 BCD) data for transmission to the computer. To accomplish both sensing and translation, the CMR employs a combination of both analog and special-purpose digital computer processing techniques.

The CMR consists of a film gate assembly, electronics module, and associated interconnecting cables. The film gate assembly is an electromechanical device employing optical and photoelectric techniques for code block sensing. The solid-state electronics module provides the analog and digital signals required for data translation. Built-in test equipment (BITE) is incorporated in the electronics module for CMR checkout and fault isolation.

2. Leading Particulars

Characteristics	Specifications	
Physical		
Size (inches)	Electronics	Film Gate
Height	10.468	12.843
Width	19.000	4.250
Depth	27.625	32.502
Weight (pounds)	150	32
Electrical		
Power	800 watts nominal (1,000 watts maximum)	
Voltage	120/208-volt, 3-phase, 4-wire Y-connected, 400 ±20 Hz (voltage, 120 line to neutral and 208 line to line)	
Functional		
Film reading speed	Forward or reverse at continuously variable speeds from 1.0 to 40 inches per minute or not more than eight code blocks per second.	
Film acceleration	Forward or reverse at 100 inches/s ²	
Film gate light source	1,000 footcandles	
Dual channel film handling capability	Two 5-inch roll film, one per channel Two 70-mm roll film, one per channel One 5-inch and one 70-mm roll film	
Diode array	Movable to accommodate front and rear channels	
Single channel film handling capability	One 9½-inch roll film	
Storage capacity-main memory	8,000 eight-bit words	
Storage capacity-buffer memory	96 five-bit words	
Environmental conditions		
Temperature	70° ±25°F	
Relative humidity	0 to 90 percent (noncondensing)	