

UNCLASSIFIED

AD NUMBER

ADB005520

LIMITATION CHANGES

TO:

Approved for public release; distribution is unlimited.

FROM:

Distribution authorized to U.S. Gov't. agencies only; Test and Evaluation; DEC 1974. Other requests shall be referred to Air Force Human Resources Lab., Williams AFB, TX.

AUTHORITY

AFHRL ltr 18 Feb 1977

THIS PAGE IS UNCLASSIFIED

THIS REPORT HAS BEEN DELIMITED  
AND CLEARED FOR PUBLIC RELEASE  
UNDER DOD DIRECTIVE 5200.20 AND  
NO RESTRICTIONS ARE IMPOSED UPON  
ITS USE AND DISCLOSURE.

DISTRIBUTION STATEMENT A

APPROVED FOR PUBLIC RELEASE;  
DISTRIBUTION UNLIMITED.

AFHRL-TR-74-108(IV)

**AIR FORCE**



ADB005520

**HUMAN RESOURCES**

**COMBAT-READY CREW PERFORMANCE  
MEASUREMENT SYSTEM:  
PHASE IIIA CREW PERFORMANCE MEASUREMENT**

By  
Richard W. Obermayer  
Donald Vreuls

Manned Systems Sciences, Inc.  
8949 Reseda Blvd  
Northridge, California 91324

FLYING TRAINING DIVISION  
Williams Air Force Base, Arizona 85224

December 1974

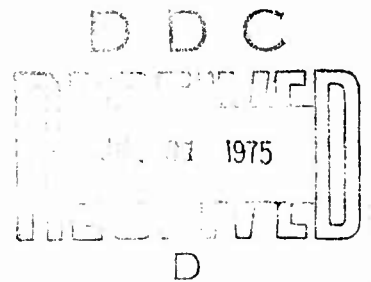

Distribution limited to U.S. Government agencies only, Test and Evaluation,  
December 1974. Other requests for this document must be referred to AFHRL/FT,  
Williams AFB, AZ 85224.

**LABORATORY**

**AIR FORCE SYSTEMS COMMAND  
BROOKS AIR FORCE BASE, TEXAS 78235**

# DISCLAIMER NOTICE

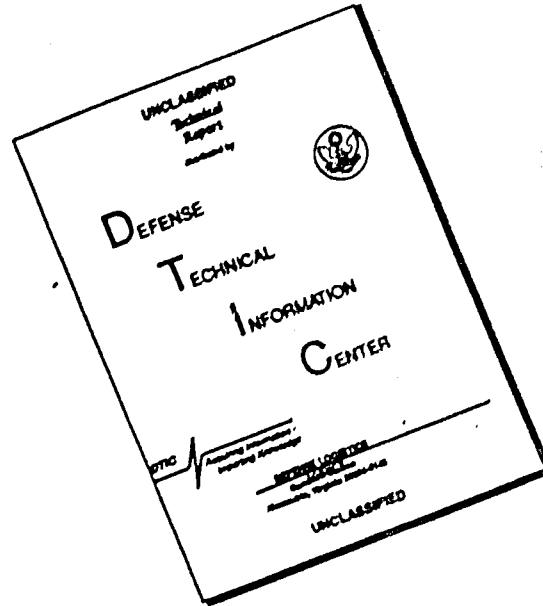

THIS DOCUMENT IS BEST QUALITY AVAILABLE. THE COPY FURNISHED TO DTIC CONTAINED A SIGNIFICANT NUMBER OF PAGES WHICH DO NOT REPRODUCE LEGIBLY.

## NOTICE

When US Government drawings, specifications, or other data are used for any purpose other than a definitely related Government procurement operation, the Government thereby incurs no responsibility nor any obligation whatsoever, and the fact that the Government may have formulated, furnished, or in any way supplied the said drawings, specifications, or other data is not to be regarded by implication or otherwise, as in any manner licensing the holder or any other person or corporation, or conveying any rights or permission to manufacture, use, or sell any patented invention that may in any way be related thereto.

This interim report was submitted by Manned Systems Sciences, Inc, 8949 Reseda Blvd, Suite 206, Northridge, California 91324, under contract F41609-71-C-0008 project 1123, with Flying Training Division, Air Force Human Resources Laboratory (AFSC), Williams Air Force Base, Arizona 85224.

Distribution limited to U.S. Government Agencies only; Test and Evaluation; December 1974. Other requests for this document must be referred to AFHRL/FT, Williams AFB, AZ 85224.

This technical report has been reviewed and is approved.

WILLIAM V. HAGIN, Technical Director  
Flying Training Division

Approved for publication.

HAROLD E. FISCHER, Colonel, USAF  
Commander

Unclassified

SECURITY CLASSIFICATION OF THIS PAGE (When Data Entered)

REPORT DOCUMENTATION PAGE		READ INSTRUCTIONS BEFORE COMPLETING FORM
1. REPORT NUMBER AFHRL-TR-74-108(IV)	2. GOVT ACCESSION NO.	3. RECIPIENT'S CATALOG NUMBER
4. TITLE (and Subtitle) COMBAT-READY CREW PERFORMANCE MEASUREMENT SYSTEM: PHASE IIIA CREW PERFORMANCE MEASUREMENT		5. TYPE OF REPORT & PERIOD COVERED Interim
		6. PERFORMING ORG. REPORT NUMBER
7. AUTHOR(s) Richard W. Obermayer Donald Vreuls		8. CONTRACT OR GRANT NUMBER(s) F41609-71-C-0008
9. PERFORMING ORGANIZATION NAME AND ADDRESS Manned Systems Sciences, Inc 8949 Reseda Blvd, Suite 206 Northridge, CA 91324		10. PROGRAM ELEMENT, PROJECT, TASK AREA & WORK UNIT NUMBERS 62703F 11230101
11. CONTROLLING OFFICE NAME AND ADDRESS Hq Air Force Human Resources Laboratory (AFSC) Brooks Air Force Base, Texas 78235		12. REPORT DATE December 1974
		13. NUMBER OF PAGES 78
14. MONITORING AGENCY NAME & ADDRESS (if different from Controlling Office) Flying Training Division Air Force Human Resources Laboratory Williams Air Force Base, Arizona 85224		15. SECURITY CLASS. (of this report) Unclassified
		15a. DECLASSIFICATION/DOWNGRADING SCHEDULE
16. DISTRIBUTION STATEMENT (of this Report) Distribution limited to U.S. Government Agencies only; Test and Evaluation; December 1974. Other requests for this document must be referred to AFHRL/FT, Williams AFB, AZ 85224.		
17. DISTRIBUTION STATEMENT (of the abstract entered in Block 20, if different from Report)		
18. SUPPLEMENTARY NOTES This report is the fourth of 7 volumes.		
19. KEY WORDS (Continue on reverse side if necessary and identify by block number) program structure C-141A crew performance measurement F-4E crew performance measurement communications measurement system		
20. ABSTRACT (Continue on reverse side if necessary and identify by block number) Research for the improvement of combat-crew training, and the efficient execution of current training programs, are heavily dependent upon good sources of information about trainee performance during and at the end of training. In an effort to improve training performance information, this study is directed to systematic definition of performance and development of methods for measurement. In accordance with the initial definition of this study, emphasis was placed on pilot performance, but it was soon recognized that avoiding the performance contributions of other crewmembers, and the interaction between crewmembers, had more serious consequences than desired. To correct this problem, additional tasks were		

Unclassified

SECURITY CLASSIFICATION OF THIS PAGE(When Data Entered)

Item 20 (Continued)

undertaken; in particular, additional data collection visits were made. The original efforts included visits related to A 7, F 4, F 106, B 52, C 141, C 130 combat crew training units. The current effort involved follow-up analyses on the F 4E and C 141A to provide additional data on fighter and heavy-multi-engine aircraft.

Unclassified

SECURITY CLASSIFICATION OF THIS PAGE(When Data Entered)

## PREFACE

This interim report was produced as a result of the Phase IIIA activities of Contract F41609-71-C-0008, entitled "Research on Operational Combat-Ready Proficiency Measurement," as altered by Modification No. P00003. This contract was performed by Manned Systems Sciences, Inc., Northridge, California, for the Flying Training Division, Air Force Human Resources Laboratory (AFSC), Williams AFB, Arizona. Major J. Fitzgerald, Chief, Combat-Crew Training Branch, was the contract monitor.

This report is one of a series of seven reports constituting the Final Report of Contract F41609-71-C-0008. These reports are listed below:

### Combat-Ready Crew Performance Measurement System:

AFHRL-TR-74-108(I): Final Report

AFHRL-TR-74-108(II): Phase I. Measurement Requirements

AFHRL-TR-74-108(III): Phase II. Measurement System Requirements

AFHRL-TR-74-108(IV): Phase IIIA. Crew Performance Measurement

AFHRL-TR-74-108(V): Phase IIIB. Aerial Combat Maneuvers Measurement

AFHRL-TR-74-108(VI): Phase IIIC. Design Studies

AFHRL-TR-74-108(VII): Phase IIID. Specifications and Implementation Plan



TABLE OF CONTENTS

<u>Section</u>	<u>Page</u>
I. INTRODUCTION . . . . .	1
Program Structure . . . . .	1
II. C-141A CREW PERFORMANCE MEASUREMENT . . . . .	5
Airlift Mission . . . . .	5
Combat Airlift Mission . . . . .	6
Crew Functions . . . . .	11
Crew Interaction . . . . .	13
Crew Interaction Measurement . . . . .	16
III. F-4E CREW PERFORMANCE MEASUREMENT . . . . .	31
Crew Performance Requirements Analysis . . . . .	32
Communication Analysis . . . . .	36
IV. COMMUNICATIONS MEASUREMENT SYSTEM . . . . .	49
Measurement Categories . . . . .	49
Candidate Communications Data System . . . . .	55
V. SUMMARY . . . . .	60

LIST OF FIGURES

<u>Figure</u>		<u>Page</u>
1	Program Sequence . . . . .	3
2	Basic Air Drop Sequence . . . . .	14
3	Example Measurement - C-141A Combat Airlift Mission . . . . .	17
4	Equipment Drop Checklist . . . . .	22
5	Navigator-Pilot Guidance-Control Information Flow . . . . .	30
6	Crew-System Relationships Non-Radar Mission . . . . .	32
7	Crew-System Relationships Radar Mission . . . . .	34
8	Typical 30 <sup>0</sup> Rocket Pattern . . . . .	37
9	Sample Flow Diagram for Pilot-RIO Communications; Heading and Bank Changes . . . . .	43-44
10	Sample Flow Diagram for Pilot-RIO Communications; Elevation Changes . . . . .	45-46
11	Sample Flow Diagram for Pilot-RIO Communications; Speed Changes . . . . .	47-48
12	Auditory Functional Data Processing . . . . .	56

LIST OF TABLES

<u>Table</u>		<u>Page</u>
I	REQUIREMENTS ANALYSIS . . . . .	4
II	AIRLIFT MISSION PROFILE . . . . .	6
III	COMBAT AIRLIFT PROFILE . . . . .	7
IV	SAMPLE OF WSO TASKS IN A NON-RADAR ENVIRONMENT . . . . .	33
V	DIRECTIVE COMMENTARY . . . . .	39
VI	DESCRIPTIVE COMMENTARY . . . . .	41
VII	OPERATIONAL BREVITY CODE . . . . .	51
VIII	CANDIDATE AUDIO DATA REDUCTION APPROACH . . . . .	58

# COMBAT-READY CREW PERFORMANCE

## MEASUREMENT SYSTEM STUDY

### I. INTRODUCTION

Research for the improvement of combat-crew training, and the efficient execution of current training programs, are heavily dependent upon good sources of information about trainee performance during and at the end of training. In an effort to improve training performance information, this study is directed to systematic definition of performance and development of methods for measurement.

The point of view taken in this study is that measurement is the means of providing information needed by training research scientists and operational training personnel. The primary goal of this study is to provide usable measurement tools for attacking problems related to combat-crew training.

In accordance with the initial definition of this study, emphasis was placed on pilot performance, but it was soon recognized that avoiding the performance contributions of other crewmembers, and the interaction between crewmembers, had more serious consequences than desired. To correct this problem, additional tasks were undertaken; in particular, additional data collection visits were made. The original efforts included visits related to A-7, F-4, F-106, B-52, C-141, C-130 combat-crew training units. The current effort involved follow-up analyses on the F-4E and C-141A to provide additional data on fighter and heavy-multi-engine aircraft.

The original study consisted of three basic phases: an analysis of measurement requirements (Phase I), a conceptual design (Phase II), and design/specification studies (Phase III). The third phase now contains four sub-parts: IIIA. Crew Performance Measurement; IIIB. Air Combat Maneuvers Measurement; IIIC. Design Studies; and IIID. Specifications.

This report presents the findings of the Phase IIIA effort. The program structure and the relation of this effort is presented in the following paragraphs. The second chapter presents results related to the C-141A; the third, results related to the F-4E. The fourth chapter discusses specific measurement system and data processing problems. Lastly, a summary is given in Chapter V.

#### Program Structure

This contract is an application of the systems approach to the design of a measurement system to produce information

relevant to combat-crew training. Consequently, the initial program phase is devoted to a definition of the requirements appropriate to such a measurement system. It is intended to establish the requirements by determining the information useful and meaningful for combat-crew training, and the requirements imposed by anticipated research topics.

The program was structured to move rapidly through six major activities shown in Figure 1. Starting with a definition of requirements for pilot proficiency measurement, a conceptual design study leads to design studies (four months) and finally specifications for a hardware/software measurement system and the final report.

After the requirements for pilot proficiency measurement were established, a short period of time was given to the consideration of the variety of possible systems and to the constraints imposed. A conceptual design, consisting of feasible alternatives has been formulated to indicate the type of information possible, the places where such information would be useful, and the possible ways such information can be collected.

In addition to a conceptual design, it was concluded that the measurement of crew/system performance (as opposed to pilot only) was quite important to a thorough description of performance for certain tasks and missions. Consequently, it was decided to undertake an additional task to define crew proficiency measurement requirements and incorporate these requirements into the conceptual design. Once defined, the resulting alternatives will be presented at a decision point meeting.

Based on the direction received at that meeting, alternatives will be analyzed to further define the details of implementation, and the nature of the tradeoffs to be considered in the selection of desired measurement systems. It is apparent that the variety of problems presented by the spectrum of Air Force combat-crew training may lead to a number of possible measurement systems. It is hoped that some commonality will be found, and that priority applications can be defined to allow detailed analysis of the benefits and costs of a measurement system with broad application. It is understood that to be "usable" a measurement system will have to be quite inexpensive in comparison with the benefits to training which will be derived.

A last decision-point meeting will be held to determine, based on the analysis performed, a specific system most directly useful as a research tool. For this system, specifications will be prepared to define the system in sufficient detail to implement the system. The specifications will include hardware descriptions, measurement definitions

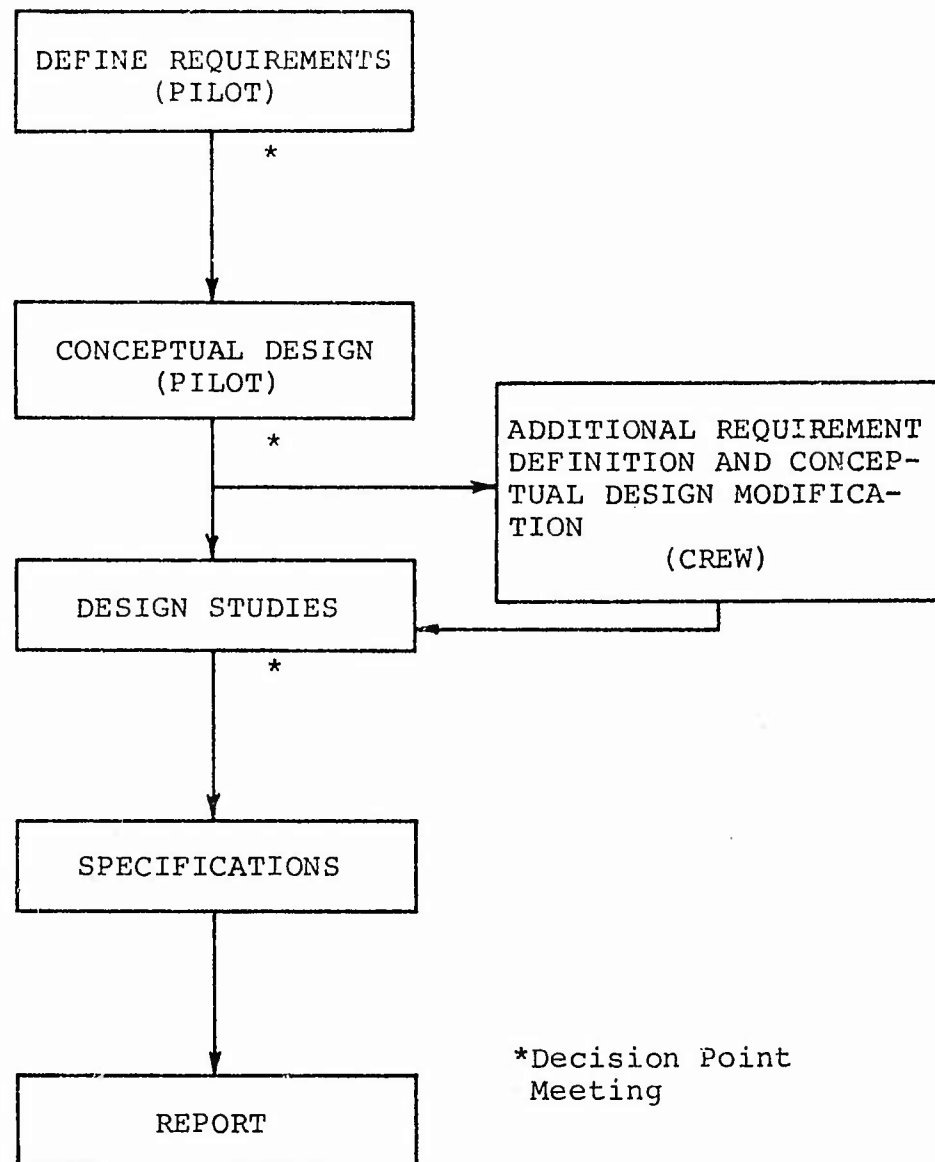

Figure 1. Program Sequence

and other software, data handling equipment, procedures and personnel. In short, the total measurement system will be defined. It is assumed, however, that such a measurement system will initially be configured for test and experimentation with the system prior to any major use of the measurement system for training applications.

The basic problem was to thoroughly define the requirements for a measurement system to sense crew interaction. To do this, a survey was conducted at those places where the information is available. Table 1 indicates the sites that have been visited.

TABLE I  
REQUIREMENTS ANALYSIS

COMBAT CREW TRAINING

A-7	Luke AFB
F-4	Davis-Monthan AFB
F-106	Tyndall AFB
B-52	Castle AFB
C-141	Altus AFB
C-130	Dyess AFB
*F-4E	George AFB
*C-141	Norton AFB
ACM	Nellis AFB

---

\*Visited specifically for the collection of information on crew performance.

## II. C-119A CREW PERFORMANCE MEASUREMENT

The C-119A is a versatile airlift aircraft capable of a number of types of missions; however, these are generally divided into two categories: an airlift mission and a combat airlift mission. The airlift mission involves transport of cargo or personnel on a global scale, between improved runways. The combat airlift mission involves flight at low levels and air drop of cargo or personnel with precision over a drop zone, which may have only recently been manned by advance troops. The combat airlift mission is accomplished by numbers of aircraft flown in formation, guided by the lead aircraft.

The crew composition is basically the same for both missions, consisting of a Pilot, Copilot, Navigator, two Engineers, and two Loadmasters. The lead aircraft in the combat airlift mission carries two navigators. The Military Airlift Command practices standardization of crewmembers so that any selection of qualified personnel from the manpower pool should be able to accomplish a mission. Thus, crews are not trained together, standardization is expected to provide required crew interaction. For the standard airlift mission, this procedure apparently works well, but for the combat airlift mission an intense degree of teamwork is necessary, requiring some training as complete crews. In particular, the lead crew trains together extensively, and each squadron has a Select Lead Crew (their best crewmembers) who are used for special missions.

### Airlift Mission

The elements of the Airlift Mission are listed in Table II. Takeoff, Climb, SID, Descent, Approach, and Land have been previously described<sup>1</sup>. The standard mission from Norton AFB is over water to Hawaii, Alaska, Japan, Korea, Southeast Asia, etc. The principal difference between such flights and CONUS flights, is, of course, the nature of navigation required. Little time is spent in an airways and TACAN environment, most of the time is spent navigating through inertial, celestial, Loran, and Consolan means. The navigator flies the airplane through the computer and autopilot most of the time. The loading and unloading phases emphasize the services of the Loadmasters; however, the tasks are procedural, and the major crew interaction lies in determination of a few items such as the gross weight and the C.G.

---

<sup>1</sup>In Volume II of this series.



TABLE II  
AIRLIFT MISSION PROFILE

Load  
Takeoff  
Climb  
Departure  
Enroute Cruise  
    ATC Environment  
    Overwater  
Descent  
Approach  
Landing  
Unload

For the long hours overwater, when the aircraft is normally on autopilot, the navigator is the only form of human guidance. Consequently, the performance during overwater flight is mainly attributable to one man; the level of crew interaction is at a low ebb. Measurement of the crew therefore evolves into measurement of the navigator's individual performance. To some degree, such tasks can be performed in a simulator environment; but in the airborne environment, there are few sources which may be used to double check the navigator's performance in using Loran, Consolan, and Celestial navigation devices. There is no way for a Flight Examiner to determine navigator performance, except to take separate fixes himself, which is not often done (except for very inexperienced trainees). Even if independent fixes are made, there are many possibilities for differences, and large tolerances are permissible. One should be able to reconstruct a flight from the navigation logs, and these can be used for evaluation of navigator performance. Subjective evaluation of the detailed operation of navigational subsystems may still be the most efficient and cost-effective method of evaluation for these tasks.

Combat Airlift Mission

Elements of the CAM profile are shown in Table III. Each of these will be described here with brevity.

Takeoff. The formation is taxied with approximately one aircraft separation to arrive at the runway precisely on time.

TABLE III  
COMBAT AIRLIFT PROFILE

TAKEOFF

ENROUTE IFR

SID

IFR FORMATION

ORBIT FIX

COMPRESS TO VRF FORMATION

ADJUST TIMING TO ACHIEVE TOT

LOW-LEVEL

VFR FORMATION

LOW-LEVEL NAVIGATION

SLOW DOWN

DROP COUNTDOWN

DROP

POST-DROP

ACCELERATE

IFR FORMATION ASSEMBLY

RETURN ROUTE

VORTAC/ILS

LAND

OVERHEAD

DOWNWIND

A stacked takeoff is used at minimum intervals of 30 sec. Briefed maneuvers are timed from the beginning of the formation leader takeoff roll; takeoff interval timing is based on the takeoff roll of the preceding aircraft. A rate of climb between 1000-1500 FPM ( $4^{\circ}$ - $6^{\circ}$  pitch) is established, accelerating to climb airspeed when flaps are retracted. Assuming an IFR departure, runway heading is maintained for  $1\frac{1}{2}$  minutes, then turning to briefed departure heading using  $20^{\circ}$  bank. A separation of  $1\frac{1}{2}$  miles is established using radar. At leveloff each aircraft is stacked 500 ft. lower than the preceding aircraft. Sections of the formation are spaced 5-min. apart.

Enroute IFR and Orbit Fix. An IFR descent and join-up in an orbit pattern is performed using intrail descent procedures at Section Leaders command, throttles are retarded to idle start, with spoilers normally deployed. Descent is at .70M/250KCAS and briefed rate of descent until base altitude is achieved and each aircraft advises the section leader that they are VFR. After all aircraft report VFR, the section leader clears the section to join VGR intrail. Departure from the orbit pattern is designed to achieve the required time over the drop zone.

Low-level. A VFR intrail formation is formed by adjusting the spacing to an interval of 2200 ft. (2-miles between element leaders) and wingtip clearance to avoid jetwash and wingtip vortices. Prior to arrival over the drop zone (DZ) a ten-second interval is established. While the wing positions fly level with the element leader, each element stacks up slightly (25-50 ft.) with respect to the previous elements. Each element lead executes changes in heading or altitude over the same geographic point. If weather is encountered, a weather penetration maneuver is performed in which the element climbs for altitude, and the wingmen turn out to achieve 2-miles lateral separation and 500 ft. altitude stacking.

Low-level enroute flight is between 500-1000 ft. AGL, following the contour of the terrain during the day, and above obstructions with 5 NM at night. The lead aircraft maintains prebriefed altitude, while other aircraft fly altitude visually. One navigator of the lead aircraft directs the formation to the initial point (IP) using radar and computer. The copilot and other navigator use visual map reading to maintain awareness of aircraft position. Time to the IP is adjusted along the route by cutting corners, or extending legs, along the route (or by varying airspeed, if necessary).

At a specific time prior to the computed air release point (CARP) each element of three aircraft slows down simultaneously, maintaining the same separation. To provide desired separation between elements, each element slows down

at 20-second intervals. The "slow down time" will normally be 5-7 minutes prior to the CARP. Throttles are retarded to idle start, decelerating to 190 KCAS. flaps are deployed to maintain position. Briefed climb/descent is maintained, and at least 150 KCAS, until reaching drop altitude. At the briefed drop altitude the serial decelerates to briefed drop airspeed, opens doors, and configures for drop (130 K for troops, and 135 K for equipment drops).

Drop Countdown. The navigator calls a 20-min., 10-min., 6-min., 3-min., and 1-min. warning prior to the drop. At each point, readiness for the drop progresses, and timing becomes more critical. Prior to the CARP, the navigator gives a countdown by second until the drop time, or "Green light", and then "Red light" over the end of the usable DZ. The principal criteria applied to the CAM is to achieve a circular drop error of less than 300 yards and time over target within 90 seconds.

Drop. Computed air release point computations are made while on the ground. For a given object, the rate of fall and time of fall can be determined from precomputed tables. The falling object is assumed to follow a path of two parts: a forward travel component in the direction of the aircraft course, and a component in the direction of the wind after the parachute is deployed. A quick computation graph is also available which allows computation within minutes of the actual drop. Ordinarily, a report is received from the ground approximately 6-minutes from drop giving balloon-measured winds. Based on these wind reports (ground wind, wind at drop altitude, and mean-effective wind), the time to the drop can be determined. The drop zone is marked with panels, and the time to drop is measured with respect to these panels by visual reference and stop watch. The direction of the aircraft track is parallel to the DZ axis, along a path indicated by the Navigator to the Pilot as "X yards to the right/left of the DZ centerline." The Pilot must crab into the wind to make this path good. The pilots of the aircraft, other than the lead aircraft, fly the standard VFR formation into the drop zone. Due to the crab required for wind effects, misleading visual spatial relationships may be presented to each pilot (e.g., while flying in the proper position, it may even look like flying on the other wing of the lead aircraft). Due to the requirement to fly formation into the DZ, the lateral drop error is primarily the responsibility of the lead aircraft, the other crews are responsible for the error in the direction of the DZ axis, and the lateral error relative to the lateral error of the lead aircraft (compensated for the effect of formation position).

Post-drop. After the drop, acceleration must be delayed approximately two minutes to provide time for the doors to be

closed, and time for the element leaders to separate two miles from the preceding element leader. Throttles are advanced to approximately 80% N<sub>1</sub> and then begin to descend/climb to departure altitude. Flaps are retracted and the flight proceeds to the ascent point. In order to provide 5-minute separation between sections during post-drop IFR vertical assembly, a series of pre-planned ascent points are employed. Within a given section, the leader turns using 20° bank and climb schedule at the ascent point, and each aircraft delays performing the same maneuver by 15 seconds after the preceding aircraft. During the climb, aircraft attain 1½ NM separation using radar.

Return Route. The return route is similar to that described in the section above, entitled "Enroute IFR". The main difference is a traffic control requirement for spacing during instrument approach and landing. Additional orbits may be preplanned, so that each section can hold until the preceding section is cleared through traffic control. Additional spacing maneuvers may take place prior to the IAF, with each member of the element intercepting the glideslope at different altitudes.

Landing. For an overhead recovery, initial approach is five or more miles from the approach end of the runway, at a minimum of 1500 ft. and 220 KCAS, element wingmen echelon on command and break over the end of the runway, 40° bank and throttles to idle start. A level turn is made, extending flaps at the proper speed, and reapplying power to maintain 160 KCAS. The before-landing checklist and spacing is accomplished on the downwind leg. The turn to final is made with a maximum of 30° bank, lowering flaps to maintain spacing for a minimum 60-second interval, and maintaining a position above the preceding aircraft. All aircraft land on the centerline, or as applicable during crosswinds, and continue to the end of the runway as rapidly and safely as possible, clearing the runway as quickly as possible with minimum use of reverse thrust.

The downwind recovery begins with entry of the downwind leg at 220 KCAS, wingmen echelon on command, and slow to arrive abeam the approach end of the runway at 200 KCAS. The lead continues for a minimum of 10 sec. beyond the approach end, retarding throttles to idle start, and turning to base with a 40° bank; succeeding aircraft turn with sufficient spacing to provide a minimum of 60-sec. landing interval. Flaps and gear are extended on base as airspeed permits. The turn to final is made with a maximum of 30° bank, and completed no less than 500 ft. AGL and ½-mile from the end of the runway. Wingmen cross the threshold with approach speed.

## Crew Functions

Flight Evaluation Forms. To determine crew functions through discussions with C-141A crewmembers at Norton AFB, the evaluation forms used during flight examinations were discussed item by item. A special form for CAM evaluation exists for the Pilot, while special entries are available for evaluation on the normal Copilot, Navigator, and Loadmaster forms. The Flight Engineer's duties are essentially the same on both the normal mission and the combat airlift mission; consequently, no special evaluation of the FE combat airlift role is needed. These forms were discussed twice, once with Stan/Eval personnel with respect to the combat airlift mission, and once with personnel of the 14th MASq about normal airlift evaluation.

Pilot/Copilot. The pilot's task is one of high precision flying and knowledge of CAM procedures; otherwise, the flying skills required are basically the same as required for the normal airlift mission (with the possible exception of the slowdown maneuver). The Copilot must be able to maintain CAM formation, operate flaps, and the air drop system. Both must have some understanding of the tasks performed by the remainder of the crew to properly coordinate during the airdrop. The Aircraft Commander (A/C) must brief the crew and keep them continuously aware of his intentions, the crew must monitor his performance to assure that no errors are made.

Flight Engineer. The main responsibilities of the FE are computation of the TOLD card (takeoff and landing data), checklists, all electrical system controls, fuel system weight balance, monitoring of all aircraft systems, and monitoring P/CP use of power. Two FEs are required: one mans the interphone, while the other performs the functions of scanner outside. The functions of the FE must be performed accurately, without major error. Many safety-of-flight items are related to the FE function; therefore, his duties are quite important, but nevertheless, there is little interaction with the remainder of the crew. Much of these duties are quite routine. An engine-running off-load is infrequently performed; in such a case, the FEs are directly related to the length of time for off-load, including manipulation of the doors. The FE does not receive any special training for CAM. Of course, the primary function of the FE is to cope with inflight failure of aircraft systems; this is difficult to assess during a normal flight.

Navigator. Two navigators (N) are used for the lead CAM crew; otherwise, only one navigator is included in the crew complement. The N will perform CARP computations, map planning, and fuel planning (monitored by FE). N gives the inflight warnings for the airdrop (20-, 10-, 6-, 3-, 1-minutes). He performs the airdrop computation from the quick computation



wind sheet, and may change the drop time as late as the second-by-second countdown preceding green light. He establishes the slow-down time -- usually 5-7 minutes from the drop to control the TOT. Enroute to the target, he will call turns and next course, and briefs on time progress; one navigator will call the time while the other backs him up. N may be responsible for such items of safety as clearance for wingmen from hazardous terrain, and winds out of tolerance for cargo safety during airdrop. During IFR formation flight, one navigator stays on the radar after Takeoff, and watches formation separation of 1½ miles, and clearance with surrounding terrain. One navigator will normally stay with the radar, doppler and computer, while the other navigator (in the lead crew) will attend to charts and the flight plan.

The normal flight check would include different items and different emphasis than the CAM flight check. The examinee would be watched for planning and preflight checks, use of DR procedures and cross-checking of the flight instruments. Course tolerances would normally be imposed by air traffic control, ETA, ADIZ, etc.; overwater position may deviate as much as 50 miles. Celestial sights must be used in combination with manual computations, and used in checking compass heading. Use of the LORAN set is evaluated throughout the mission because there are so many changing variables. Use of the radar for weather penetration and providing guidance to the air field is evaluated; for example, the examinee may be asked to take a fix on an island. The examinee will be quizzed thoroughly on the use of the computers. They will use the computer coupled and uncoupled to the autopilot; coordination is required with the pilots to uncouple at times during the use of TACAN guidance to prevent the computer from taking 30° cuts on the course. The use of the digital computer for flying grid is noted. In general, the navigator is watched for safety of flight items, and the application of well-planned and smoothly-paced work habits. The examiner may go over the logs and charts afterwards (e.g., Form 25, Flight Plan and Record; Form 25b, Computer Flight Plan; Form 26, Navigators Flight Records; Form 27, Range Control; Form 115, Message; Form 193, Flight Folder).

Loadmaster. Two loadmasters fly on each mission. For CAM, one loadmaster stays on the interphone to run checklists, while the other LM does the physical checks. The loadmasters must load the cargo and maintain the C.G. within tolerances; for cargo, they must load so that the C.G. is within ±2 inches of 25% MAC. However, since loads are on pallets normally, this is not too difficult. For passenger cargo, LM must give the passenger briefings and attend to passenger comfort (blankets, box lunches). For medical evacuation flights, flight nurses are along to attend to patients. CAM is the only mission where high level of crew interaction takes place, and rapid well-coordinated action by the LMs is

necessary. In particular, any mishap after the 3-minute warning is likely to cause a 10% drop to occur. If the navigator is late in giving such a warning, it is also very likely that the drop will not occur. The LM reports when any paratroopers delay in jumping, as this will affect the score on that run.

During the normal airlift mission, the LM does not have much effect on the performance of the rest of the crew unless the cargo is improperly loaded and/or the C.G. is out of tolerance. The occasions for jettisoning cargo are rare with the C-141A. The major emphasis during the flight check is on preplanning, forms, cargo handling, normal and emergency procedures.

### Crew Interaction

Standard Airlift Mission. The standard airlift mission is not characterized by a high degree of apparent crew interaction. The standardization of aircrews in MAC is such that a group of total strangers may be selected from the manpower pool and be fully expected to perform a successful mission.

The two loadmasters have extensive duties regarding the loading, unloading, and care of cargo; however, their interaction with the remainder of the crew occurs at time of cargo loading and unloading, principally, gross weight, and weight and balance. Similarly, the two Flight Engineers are concerned with the state of all aircraft systems; however, unless some sort of emergency occurs, interaction with the remainder of the crew is limited to checklist reporting, and preparation of the TOLD (takeoff and landing data) card for the pilots. A greater degree of interaction occurs between the Pilot, Copilot, and Navigator. The Pilot (Aircraft Commander) normally flies the aircraft unless the Copilot temporarily relieves him. The Copilot will normally fly very few takeoffs and landings in his career; for specialized instrument approaches he may fly the throttles. Otherwise the Copilot duties are restricted to running checklists and handling communications. The Navigator operates the equipment of the navigational systems to determine position and course. This information is communicated verbally, to the pilots through cockpit displays, and directly to the aircraft through the autopilot. In the terminal area, both the Copilot and Navigator monitor the flight for conformance with air traffic control procedures; the Navigator monitors the radar to assure proper terrain clearance.

Combat Airlift Mission. Since enroute IFR portions of the combat airlift mission are essentially the same as for the standard airlift mission, the discussion above applies to both. Figure 2 shows the basic air drop sequence described in the following paragraphs:



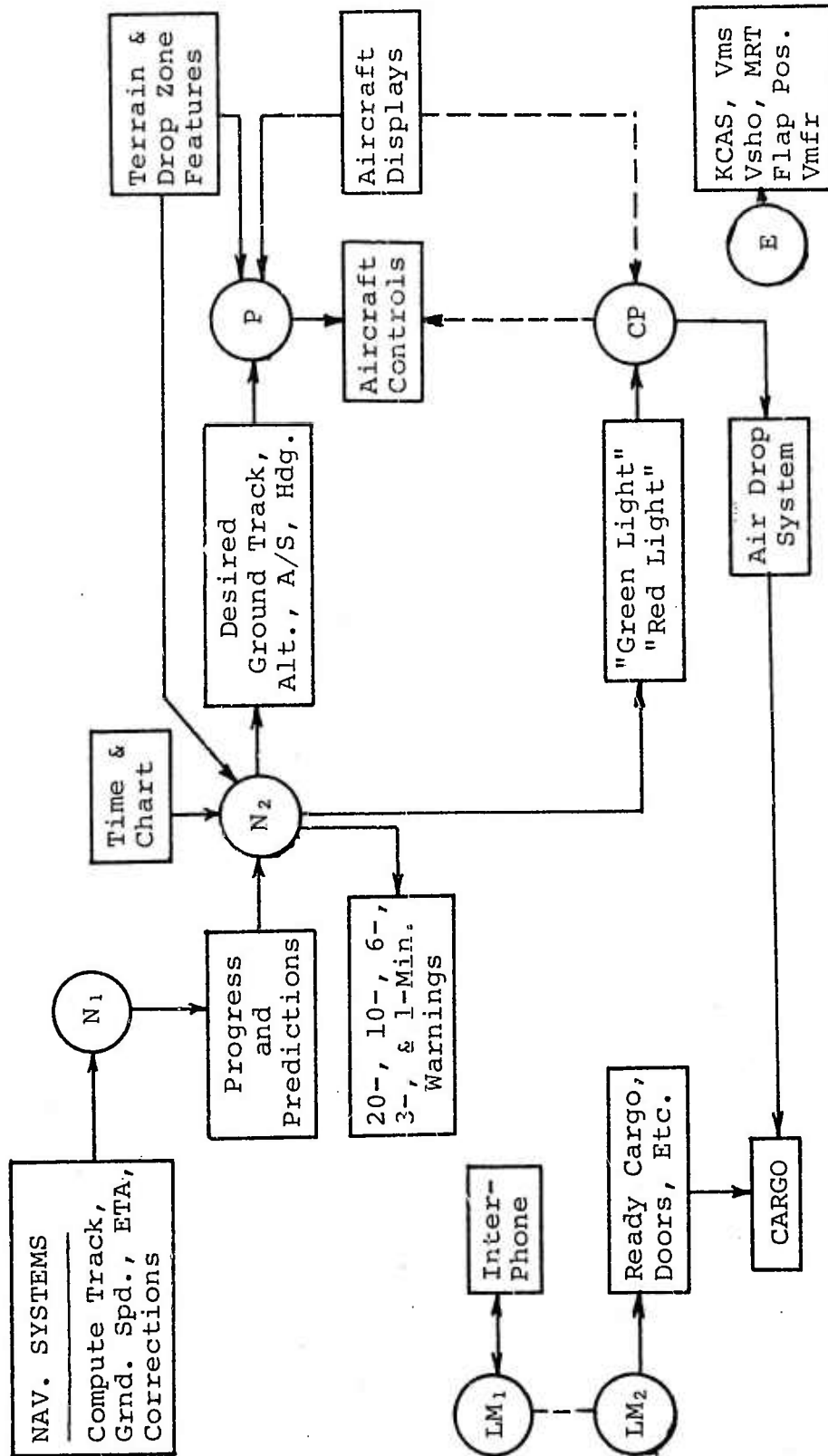

Figure 2. Basic Air Drop Sequence.

The navigator is quite important, since he is largely responsible for the success of the air drop. The time over the target (TOT) and the accuracy are determined by the navigators (there are two on the lead aircraft of the formation), but they must act through the other crewmembers to produce the desired result. The two navigators act as a tight-knit team. They must have major strategies and working procedures developed prior to flight time, as there will be little time for such during the flight. One navigator (N<sub>1</sub>) will normally situate himself behind the Pilot, where he has good visibility forward and to both sides of the aircraft, and with direct communication with the other navigator (N<sub>2</sub>) directly behind him. The other navigator (N<sub>2</sub>) will be positioned at the navigation console, where he can have direct access to the navigation displays, computer, radar, and the working area available there. N<sub>1</sub> acts as coordinator for the flight: He is in a position to see outside better than anyone else aboard, so he directs the flight over the ground using chart and stopwatch. He assures that the ground path is precisely over the proper checkpoints, that the pilots are well briefed on the proper relationship to other aircraft in the formation, the proper track across the drop zone, and what is desired in terms of altitude and speed control. He assures that the copilot receives timely wind and clearance information from the team at the drop zone. N<sub>2</sub> works with the digital computer, and hand computer, to revise the path and/or speed as desired to achieve TOT, the proper time for slowdown, and may even recompute the CARP within seconds of the drop zone if more recent wind information is available. Consequently, N<sub>2</sub> provides information affecting the TOT and the drop error; N<sub>1</sub> must attempt to ensure that the required checkpoints and CARP are achieved as desired by N<sub>2</sub>. Except for the display of computer-derived information on the pilots' displays, all of the interaction information is communicated verbally.

If the aircraft is not the lead aircraft in the formation, only one navigator (N<sub>2</sub>) is included in the crew, as the function of N<sub>1</sub> is performed by following the lead aircraft. The lead crew assumes responsibility for TOT and path over the drop zone.

The pilots, of course, are in direct control of the aircraft. During VFR formation, the copilot may fly the aircraft if he is combat airlift qualified; but ordinarily this will depend upon the Aircraft Commander and whether or not he desires to be relieved, or to provide training. Position in formation is maintained visually, with reference to the radar and timing of shadows for spacing information. N<sub>2</sub> and the Copilot will keep close watch on the radar during joinup. The Aircraft Commander will keep the radar in his visual scan, and N<sub>2</sub> will monitor. If flying lead, care will be taken during turns to avoid banks over 20° and avoidance of terrain, to allow wingmen to follow easily and stay out of the

terrain (i.e., inter-aircraft coordination). During slowdown and approaching the drop zone, both pilots and N<sub>1</sub> will confer on formation position and the proper path through the drop zone. N<sub>1</sub> will countdown to greenlight, and the Copilot controls the release of the cargo through the rear door, however, they both must be sure that they have heard the Loadmasters announce that the cargo is ready over the interphone.

The Loadmasters are busy in the back of the aircraft since the announcement of the 20-minute warning. One Loadmaster (LM<sub>1</sub>) mans the interphone, with the other (LM<sub>2</sub>) performing the physical checks. The Loadmasters perform checklist items and must respond at the 20-, 10-, 6-, 3-, and 1-minute warnings. As time progresses during the last 20-minutes, any delay, confusion, or mistakes become increasingly critical. If a door-opening difficulty is encountered in the last minutes, or if the 3- or 1-minute warnings are given late, it is quite probable that a "No-drop" will be called.

The Flight Engineers do not have specific roles in the air drop checklists. TOLD cards must be read for each takeoff and landing made in the flight. Similarly, for each air drop, the Flight Engineer must compute drop airspeed, minimum spoiler speed, shaker onset speed, military rated thrust, flap position, and minimum flap retract speed. Otherwise, the role of the Flight Engineer is much the same as on a conventional mission.

#### Crew Interaction Measurement

A measurement analysis was previously performed for the C-130E to determine measurement requirements for the assessment of pilot performance. While this analysis generally excluded the evaluation of efforts of the other crewmembers, it was found to be impossible to avoid the measurement of total system performance in the accomplishment of the air drop mission, because such data are needed to properly interpret pilot performance. Thus, the example measurement produced was really quite representative of the performance of the total crew, with some emphasis on the contributions of the pilots. This conclusion was generally supported by data collected through interviews at Norton AFB in regard to performance of the total crew. What is needed in addition to the example measurement previously presented, is information which is specific to the contributions of other crewmembers, and in particular, information related to the interactions between crewmembers.

Example measurement. The example measurement shown in Figure 3 for the C-141A Combat Airlift Mission, is a revision and expansion over that formerly developed for the C-130E. Upon examination, it may be seen that the illustrative measurement suggested may be classified as follows:

Mission Briefing:

Wx, routes, aircraft, procedures, navigation, cargo,  
DZ descrip.

Pre-Taxi:

Checklists: Before starting engines, Starting engines,  
Before Taxi  
Command markers, Communications setup

Taxi:

Time: (N countdown)      Nose-Tail sep.: (min,max,avg)  
Brakes: (no. & dur.)      Thrust: (min/max)  
Taxi checklist

Takeoff:

Checklists: Before T.O., Lineup  
Time behind leader: (N countdown)      Centerline dev.: \_\_\_\_\_  
Rotation speed: \_\_\_\_\_      Thrust: \_\_\_\_\_

Joinup:

After T.O., climb checklist  
Lead: HDG: \_\_\_\_\_ Time at departure HDG: \_\_\_\_\_ A/S: \_\_\_\_\_  
Alt.: \_\_\_\_\_  
Wing: Time to join: \_\_\_\_\_ P/CP/N communications: \_\_\_\_\_

Acceleration:

Thrust: \_\_\_\_\_ Time: \_\_\_\_\_ Spacing: (Rng/brg/ $\Delta$ alt)

Standard Instrument Departure:

Time for turn: (N countdown)  
Crew calls: (alt. restrictions, level-off, terrain  
clearance)  
Other items as dictated by the flight plan

IFR Formation:

Spacing - lead referenced: (Rng/brg/ $\Delta$ alt)  
Crew checks: (radar/rng/brg)  
Time over checkpoints: \_\_\_\_\_

Orbit Fix:

Descent checklist  
IFR formation spacing: (rng/brg/ $\Delta$ alt)  
VFR formation spacing: (rng/brg/ $\Delta$ alt)  
Time Arrive/Depart Fix: \_\_\_\_\_/\_\_\_\_\_

Each Low-Level Leg:

ATA: \_\_\_\_\_ Pos. each HDG change: \_\_\_\_\_ Pos. "over" fix: \_\_\_\_\_  
Spacing: \_\_\_\_\_ Alt.: \_\_\_\_\_ Bank: (max) Terrain  
Clearance: \_\_\_\_\_  
Dev. from track: \_\_\_\_\_ Nav. directions: \_\_\_\_\_

Figure 3. Example Measurement  
C-141A Combat Airlift Mission

Slowdown:

Time: (N countdown) Location: \_\_\_\_\_ Throttles to  
Idle: \_\_\_\_\_  
Flaps A/S: \_\_\_\_\_ Drop alt.: (level-off alt, time)  
Drop A/S: \_\_\_\_\_  
P/CP/N communications

Drop Countdown:

Interphone: P/CP/N<sub>1</sub>/N<sub>2</sub>/LM<sub>1</sub>

	<u>Pilots</u>	<u>Nav.</u>	<u>LM</u>	
	*	*	*	
20-min:	_____	_____	_____	
10-min:	_____	_____	_____	
6-min:	_____	_____	_____	*Time each item, and
3-min:	_____	_____	_____	total check complete,
1-min:	_____	_____	_____	or not completed.

Call for DZ winds: (surface, drop alt., mean eff.)  
Command Marker setup

Drop:

Nav. instructions to DZ: \_\_\_\_\_ Track DZ: \_\_\_\_\_  
Time - green light: \_\_\_\_\_ Location: \_\_\_\_\_  
Position of Lead: \_\_\_\_\_ CARP: \_\_\_\_\_  
Time - red light: \_\_\_\_\_ Location: \_\_\_\_\_  
Alt: \*\* A/S: \*\* HDG: \*\* G/S: \*\* Drift: \*\*

\*\*At green and red lights, and min/max/avg between lights.

Range Score: (yds/clock for lead and given aircraft)  
Difficulties reported: E.g., LM reports jumpers delay  
at green light

Post-Drop:

Post-drop checklist: time each item and total check  
complete  
Time of turn: \_\_\_\_\_ Accel time: (N countdown, call from lead)  
Thrust: (time, amount) A/S: \_\_\_\_\_ HDG: \_\_\_\_\_  
Spacing - VFR formation: (rng/brg/Δalt)  
Other items as dictated by flight plan  
Interphone

Return Route:

Request clearance: \_\_\_\_\_ Climb checklist: \_\_\_\_\_  
Time turn to ascent pt.: \_\_\_\_\_ Accel. time: \_\_\_\_\_ Thrust: \_\_\_\_\_  
A/S: \_\_\_\_\_ V/V: \_\_\_\_\_ Spacing - IFR: (rng/brg/Δalt)  
Other items as dictated by flight plan/clearance  
Cruise checklist

Figure 3. Example Measurement (Continued).

Land (Overhead):

Descent checklist: Before landing checklist:  
After landing checklist:

P/CP communications

Initial: A/S: \_\_\_\_\_ Alt: \_\_\_\_\_ HDG: \_\_\_\_\_ Spacing: \_\_\_\_\_

Echelon: (command, spacing)

Break: Roll: \_\_\_\_\_ Thrust: \_\_\_\_\_ Alt: \_\_\_\_\_ A/S: \_\_\_\_\_

Downwind: A/S: \_\_\_\_\_ Alt: \_\_\_\_\_ Spacing: \_\_\_\_\_

Final: Roll: \_\_\_\_\_ A/S: \_\_\_\_\_ Alt (½-mile): \_\_\_\_\_ Flaps: \_\_\_\_\_

Spacing: \_\_\_\_\_

Time behind lead aircraft

Touchdown: Centerline dev.: \_\_\_\_\_ Runway dist.: \_\_\_\_\_

Time behind: \_\_\_\_\_ V/V: \_\_\_\_\_ A/S: \_\_\_\_\_

Use of Reverse: \_\_\_\_\_

Post-Mission:

Nav. Records: Flight plan, maps, CARP computations  
: Post-mission critique

Eng.: TOLD cards, Airdrop quick ref. data  
: Post-mission critique, maintenance writeups

Loadmaster: Post-mission critique

Pilots: Post-mission critique

Figure 3. Example Measurement (Continued).

1. Aircraft parameters: while aircraft parameters (e.g., airspeed, altitude) are perhaps most directly related to the performance of the pilots, such performance may often be in response to the performance of other crewmembers; hence, such data are needed for the assessment of other crewmember performance as well as the pilots.

2. Position with respect to other aircraft: principally, with respect to the lead aircraft during IFR formation, VFR formation, joinup, or the traffic pattern; performance here may be attributable to the pilots of the lead aircraft, the wing-position aircraft, or both.

3. Position with respect to the ground: generally, the position and/or altitude with respect to the surrounding terrain; measures derived from these data may be related to the performance of the pilots, the navigators, or all of these.

4. Specially sensed data: some data may require special sensors, such as the use of brakes, or to determine liftoff.

5. Communications: data specific to crew interactions may be derived from checklists, transmissions, required and voluntary communications.

6. Subjective data: other information may be derived from the post-mission critique, and special interviews, which will reflect on crew performance and interaction (i.e., underlying factors which may not be directly observable).

Subjective data would probably be collected entirely on the ground directly after the mission, using tape-recorded interviews and questionnaires to document the results. The other data would require an airborne data collection system. Such an airborne system must record aircraft parameters, the relative position of the lead aircraft either through the windscreen or the radar, geographic location either through coordinates derived from the navigational systems or through direct view of the terrain underneath the aircraft, and crew communications through the interphone.

Much of this information would be needed for measuring total system performance; however, the measurement of crew interactions places a much heavier emphasis on the recording of crew communications. The interphone and interplane communications provide the most direct source of information about the instructions given the crew by the lead aircraft, the instructions of the navigator, whether the pilots erred or whether they were given erroneous information, whether the loadmasters were late in getting the cargo ready or were given a late warning, and other information relating to crew interaction.



Crew communications. Much of the crew communications have been standardized and abbreviated into the form of checklists. In addition to standard checklists (before starting engines, starting engines, before taxi, taxi, before takeoff, lineup, after takeoff, cruise, descent, before traffic pattern, after landing, engine shutdown, and, before leaving aircraft) other checklists are included for the combat airlift mission (20-minute check, 10-minute check, 6-minute check, 3-minute check, and 1-minute check); checklists for and equipment drop are presented in Figure 4. While these checklists are quite routine, documenting whether a given item in a checklist was performed, and the time of performance, can provide a valuable piece of information in diagnosing crew interaction and total crew performance. For example, if the navigator does not call a 1-minute warning the air drop will not be made; if he calls the warning late, the Loadmasters may not complete their 1-minute check items. It will probably be necessary to record communications from each interphone, so that evidence of two simultaneous transmissions is available. If, for example, the Navigator starts counting at the same time the Loadmaster calls that his 1-minute check is completed, a "no-drop" will be called because it will be believed that the Loadmasters are not ready for the cargo to go out of the door.

The major communications of the Engineer to the Pilot (E-P) and the Loadmaster to the Pilot (LM<sub>1</sub>-P) will be included in checklist responses. The second Loadmaster must climb around the cargo in performing the checklist, so does not wear a headset. The other Loadmaster (LM<sub>1</sub>) monitors the interphone and visually observes the checks physically performed by LM<sub>2</sub>; hence, there are generally no recordable conversations between the Loadmasters (LM<sub>1</sub>-LM<sub>2</sub>). LM<sub>1</sub> announces that a given check is complete. N<sub>1</sub> will use Hot Mic during the last minutes of the drop; otherwise, conversations between navigators (N<sub>1</sub>-N<sub>2</sub>) will not always be over the interphone, and therefore not always be recordable.

The remaining communication pairs, pilot and copilot (CP-P), and navigator and pilot (N<sub>1</sub>-P), are the most important. The copilot has some normal responsibilities, but these may be changed unpredictably by the pilot. The communications between pilots, who are normally Hot Mic, indicate the tasks of each pilot, information provided by one to another, how they are interacting, and often an immediate assessment of the performance of the other. The Navigator to Pilot link is the principal flow of guidance information (see Figure 5); as such, it provides command data upon which the pilots are to control the aircraft, presumably in an appropriate manner to accomplish the mission. The navigator of the lead crew gives guidance commands to the drop zone which directly affect the drop scores of the entire formation.



20-MINUTE CHECK

*Pilots*

1. 20-Minute Warning - "ACKNOWLEDGED" (CP, LM)

NOTE: If immediate response is not made by the loadmaster, the copilot will challenge him.

2. No. 3 Hyd Sys ON - "ON" (E)

3. Depressurize - DEPRESSURIZED (E)

The flight engineer will turn the floor heat and air conditioning OFF. He will respond when the aircraft is depressurized.

4. Door Arm Switch - "ARMED, LOADMASTER CLEARED TO OPEN PRESSURE DOOR." (P)

5. Pressure Door - "OPEN" (LM)

6. Door Arm Switch - "OFF" (P)

7. Performance Data - "COMPUTED" (CP)  
The flight engineer will compute minimum spoiler

*Navigator*

1. "Crew - 20-MINUTE WARNING" (N)  
Navigator will advise crew twenty minutes prior to CARP.

*Loadmaster*

Loadmaster will not wait to be challenged for completed checks, it will be given when completed.

1. 20-Minute Warning - "ACKNOWLEDGED LOADMASTER" (LM)
2. Inspection of Load and Extraction System - COMPLETE
  - a. Complete extraction system will be inspected.
  - b. Remove parachute tie-down strap.
  - c. Check aft of load for Rail lock inspection for retraction of locks aft of load on both rails.
  - e. Insure safety pins are removed from cargo parachute release assemblies.

3. Aft Emergency Chains - PREPOSITIONED

4. Retractable Lips - RETRACTED AND SECURED

Figure 4. Equipment Drop Checklist.

*Pilots*

speed, shaker speed, MRT, and flap setting based on GW for drop and pre-briefed airspeed. Flap retract speed will be computed for drop weight.

8. Command Markers - "SET" (CP, P)  
Both pilots shall set the altitude command marker to the briefed DZ delivery altitude and set airspeed command markers to drop airspeed.

9. 20-Minute Check - "20-MINUTE CHECK COMPLETED" (LM, P)

This response will be completed only after receipt of loadmaster's 20-minute check.

*Loadmaster*

5. Auxiliary Pressure Door Locks and Cam Jacks - REMOVED AND STOWED

NOTE: Request clearance from pilot prior to removal to insure cabin pressure differential is negative.

6. Anchor Cable Restraint hooks - REMOVED

7. Pressure Door - "OPEN" (LM) Open pressure door by aft control.

8. Aft End of Ramp - TAPED

9. Aft Anchor Supports - CHECKED

Supports must be extended to air-drop position.

10. Notify Pilot - "20-MINUTE CHECK COMPLETED LOADMASTER" (LM)

*Navigator*

10-MINUTE CHECK

1. "Crew - 10-MINUTE WARNING" (N)  
Navigator will advise crew 10 minutes prior to CARP.

1. 10-Minute Warning - "ACKNOWLEDGED" (CP, LM)  
NOTE: If immediate response is not made by the loadmaster, the copilot will challenge him.

1. 10-Minute Warning - "ACKNOWLEDGED LOADMASTER" (LM)

2. Parachutes - ON  
Insure all personnel in cabin

Figure 4. Equipment Drop Checklist (Continued).

*Pilots*

- 2. 10-Minute Check - "10-MINUTE CHECK COMPLETED" (LM, CP)  
This response will only be completed after receipt of loadmaster's 10-minute check.

*Navigator*

NOTE: Navigator will advise pilot when reaching slow down point for type I or II

*Loadmaster*

- don parachutes.
- 3. Notify Pilot - "10-MINUTE CHECK COMPLETED LOADMASTER" (LM)

6-MINUTE CHECK

- 1. 6-Minute Warning - "ACKNOWLEDGED" (CP, LM)  
NOTE: If immediate response is not made by the loadmaster, the copilot will challenge him.

- 1. "Crew - 6-MINUTE WARNING" (N)  
NOTE: Navigator will advise crew six minutes prior to drop time.

- 1. 6-Minute Warning - "ACKNOWLEDGED LOADMASTER" (LM)
- 2. Confirmation - "RED LIGHT ON" (LM)

- 2. Red Light - "ON" (CP, LM)

- 2. Radar-Beacon Mode (serial leads only)

- 3. Right Hand Locks - CHECKED  
Insure yellow tabs are locked in place on mechanism being used for aft restraint. Visually check to insure that the detents are engaged in the platform.

- 3. 6-Minute Check - "6-MINUTE CHECK COMPLETED LOADMASTER" (LM)

- 4. Door Arm Switch - "ARMED" (P)

- 4. Door and Ramp - CLEAR

- 5. 6-Minute Check - "COMPLETED" (CP)

- 5. ADS Armed Switch - DEARMED
- 6. Notify Pilot - "6-MINUTE CHECK COMPLETED LOADMASTER" (LM)

Figure 4. Equipment Drop Checklist (Continued).

Pilots

1. 3-Minute Warning - "ACKNOWLEDGED" (CP, LM)
2. Ramps and petal doors - "DOORS ARE CLEAR" (LM)
3. All Door Switch - "OPEN" (P, CP)  
Copilot will not open doors until commanded by the pilot.  
WARNING: Do not exceed door operation airspeed restrictions outlined in TO 1C-141A-1.
4. Petal Doors and Ramp - "OPEN" (LM)
5. 3-Minute Check - "3-MINUTE CHECK COMPLETED" (LM, CP)  
This response will be completed only after receipt of loadmaster's 3-minute check.

Navigator

3-MINUTE CHECK

1. "Crew - 3-MINUTE WARNING" (N)  
Navigator will advise crew three minutes prior to drop time.  
Confirm DZ track and alignment  
Hot Mic Talk off

Loadmaster

1. 3-Minute Warning - "ACKNOWLEDGED LOADMASTER" (LM)
2. Ramp and Petal Doors - "DOORS ARE CLEAR" (LM)
3. Petal Doors and Ramp - "OPEN" (LM)
4. Left Hand Locks - UNLOCKED AS REQUIRED  
Do not unlock LH locks until doors are opened to airdrop position. The assistant loadmaster, moving forward as locks are sequentially unlocked will visually check to insure each lock is disengaged.
5. Notify Pilot - "3-MINUTE CHECK COMPLETED LOADMASTER" (LM)

Figure 4. Equipment Drop Checklist (Continued).

1-MINUTE CHECK

CAUTION

IF ANY UNSAFE CONDITION IS OBSERVED BY ANY CREWMEMBER HE WILL STATE "NO DROP"

*Pilots*

1. 1-Minute Warning - "ACKNOWLEDGED LOADMASTER" (LM)

The one minute check will not be verbally acknowledged by the copilot.

2. Transmission selector switch - INTERPHONE (CP)
3. 1-Minute Check - "1-MINUTE CHECK COMPLETED" (LM, CP)

*Navigator*

1. "Crew - 1-MINUTE WARNING" (N)

Navigator will advise the crew one minute prior to CARP.

2. CARP Countdown (N)  
Navigator will provide countdown to CARP, five seconds minimum is required.

*Loadmaster*

1. 1-Minute Warning - "ACKNOWLEDGED LOADMASTER" (LM)
2. Manual Control - REMOVE PIN
3. Manual Control and ADS Armed Switch - STANDBY
4. Assistant Loadmaster - STANDBY RIGHT HAND RAIL REMOTE CONTROL

WARNING: RIGHT HAND LOCKS TO BE EMERGENCY RELEASED ON SINGLE PLATFORM DROS ONLY

5. Notify Pilot - "1-MINUTE CHECK COMPLETED LOADMASTER" (LM)

ADS Arming Switch - at Navigators count of five, position the switch to the ARMED position.

Figure 4. Equipment Drop Checklist (Continued).

ARRIVAL AT CARP

*Pilots*

1. Chute Release/Green Light Switches ON at navigators command.  
The copilot activates the chute release first and turns the green light switch ON.

2. Notify Pilot - "ALL CLEAR/MALFUNCTION" (LM)

3. Copilot will turn the green switch OFF when navigator states "RED LIGHT."

*Navigator*

1. Over CARP - "GREEN LIGHT" (N)  
Navigator states "GREEN LIGHT" when over the CARP.
2. DZ End - "RED LIGHT" (N)  
Navigator states "RED LIGHT" when over end of useable DZ.

*Loadmaster*

1. Green Light - "GREEN LIGHT ON" (LM)  
If extraction fails to release electrically, pull manual control handle to release position.

2. Notify Pilot - "ALL CLEAR" or "MALFUNCTION" (LM)  
If a malfunction occurs advise the pilot of the nature and proceed with emergency procedures.

3. Red Light - "RED LIGHT ON" (LM)

POST DROP CHECK

1. Loadmaster Advisory - "PETAL DOORS CLEAR" (LM)

2. All Door Switch - "CLOSED" (CP)  
This action will not be accomplished prior to clearance from loadmaster.

1. Advise Pilot - "PETAL DOORS CLEAR" (LM)

2. Notify Pilot - "DOORS AND RAMP CLOSED" (LM)

NOTE: If aircraft is to be pressurized; stow anchor cables, remove tape from ramp, close pressure door, install pressure door locks and cam jacks.

Figure 4. Equipment Drop Checklist (Continued).

*Pilots*

*Navigator*

*Loadmaster*

3. Doors and Ramp - "DOORS AND RAMP CLOSED" (LM)

4. Flaps - "Up" (P, CP)  
Retract flaps on pilot's command.

5. No. 3 Hyd Sys OFF - "OFF" (E)

Do not turn OFF No. 3 Hyd Sys until all required doors are closed and flaps are fully retracted.

6. Red light - OFF

7. Post Drop Check - "POST DROP CHECK COMPLETED LOADMASTER" (LM)

8. Pressurization - "AS REQUIRED" (P)  
Do not pressurize until loadmaster's check is complete and the pressure door is closed and locked and checked.

9. Door Arming Switch - "OFF" (P)

10. ADS Panel - "SET"

3. Manual Control - Install Safety Pin. If manual control was used, position control to "Safe" position and install safety pin.

4. Retainer Straps - REMOVED

5. Cargo Compartment Lights - WHITE

6. Left Hand Locks - Set/ Locked Out - As Required  
NOTE: If more platforms are to be dropped, inspect the left hand locks used on the previous drop to insure they are locked out. Locks not locked out will be manually locked out.

7. Right Hand Locks - set/ locked out - As Required.  
NOTE: If more platforms are to be dropped, insure locks used on previous drop are locked out.

8. ADS Arming Switch - RETURN TO DEARMED POSITION

9. LH Remote Control Handle - STOWED

10. Parachutes - OFF

Figure 4. Equipment Drop Checklist (Continued).

*Pilots*

- 11. Post Drop Check -  
"COMPLETED" (CP)

*Navigator*

*Loadmaster*

- 11. Notify Pilot - "POST  
DROP CHECK COMPLETED  
LOADMASTER" (LM)  
Secure any loose items and  
check general condition of  
cargo compartment.

Figure 4. Equipment Drop Checklist (Continued)



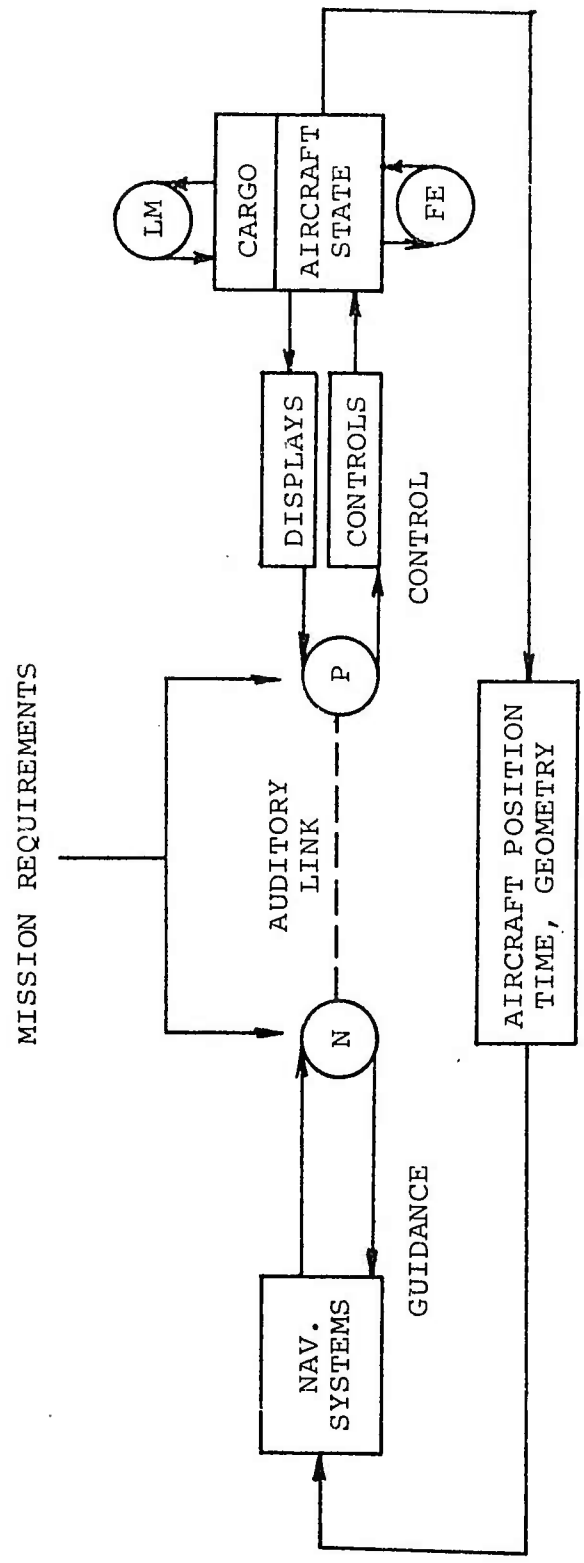

Figure 5. Navigator-Pilot Guidance-Control Information Flow.

### III. F-4E CREW PERFORMANCE MEASUREMENT

Performance measurement requirements can be visualized at two general levels, (1) total crew-system performance, and (2) crewmember-system performance. The total crew-system performance level measure the effect of the combined performance of all crew members on vehicular or mission performance. At the crewmember-system level, the effect of each crewmember can be described in terms of his performance with the subsystems under his control. Since the composite of each crewmember working with his subsystems will in some way affect mission performance, the interaction between the crew members must be identified, and measurement of that interaction defined.

Total crew-system or mission requirements differ little from previously specified pilot-system performance requirements<sup>1</sup>. For example, intercept performance measurement was described for the F-106 pilot-system. Ground attack, BFM/ACM and latter portions of refueling were described for the F-4 and A-7. Similarly, measurement of transition and instrument phases was described at the pilot-system level. The F-4E crew must perform the same maneuvers that are performed by the single pilot aircraft (A-7 and F-106); therefore, the existing system performance measurement "specification" accurately reflects the total crew-system performance requirements.

At the crewmember-system performance level, the measurement situation changes slightly because the tasks that were allocated to one pilot have been split-up between the crew members. The F-4E configuration forces a general division of duties based on the rear-seat placement of the radar, the INS, WRCS and EW controls. For those tasks which the pilot retains primary responsibility, the previous measurement requirements analysis still applies. For mission segments which require the use of rear-seat subsystems, the crewmember-system performance is identifiable because there is a clear definition of tasks for the second crewmember, his tasks are related to specific subsystems, and within those subsystems measurement points are available. However, since the aircraft carries a second crewmember, his participation can be a valuable asset in any flight regime, not just those that involve his subsystems.

For the F-4E rear seater, the performance measurement situation for tasks that do not involve radar, INS, WRCS, or EW becomes more vague because the performance and coordination of

---

<sup>1</sup>In Volume II of this series.

two people are immersed in the total system performance, the "split" or division of duties is not always a clean one. In current practice the division of duties is not defined; crew coordination is left up to the discretion of each aircraft commander. In order to generate measurement, however, the interaction between the crew must be understood well enough to permit measurement development. An analysis of crew performance requirements was conducted to develop such an understanding in order to specify measurement points.

### Crew Performance Requirements Analysis

It is helpful to distinguish between mission segments that are primarily non-radar and segments that are radar oriented because the crew tasks change. The pilot's task in the non-radar environment are more clearly related to system performance than the WSO's tasks. The WSO's tasks and pilot tasks are probably equally related to system performance in the radar environment. Each environment is briefly reviewed, fully realizing that this dichotomy is artificial; there are overlapping task areas.

Non-radar mission. An analysis of training documents and summary of interview with instructor and Stan/Eval pilots (Table IV) reveals that the WSO duties in the non-radar category can be simply stated: Be a good copilot. That definition, though accurate, is not sufficient for measurement. For measurement development purposes, one can examine the Pilot--WSO--Aircraft relationship with the use of Figure 6.

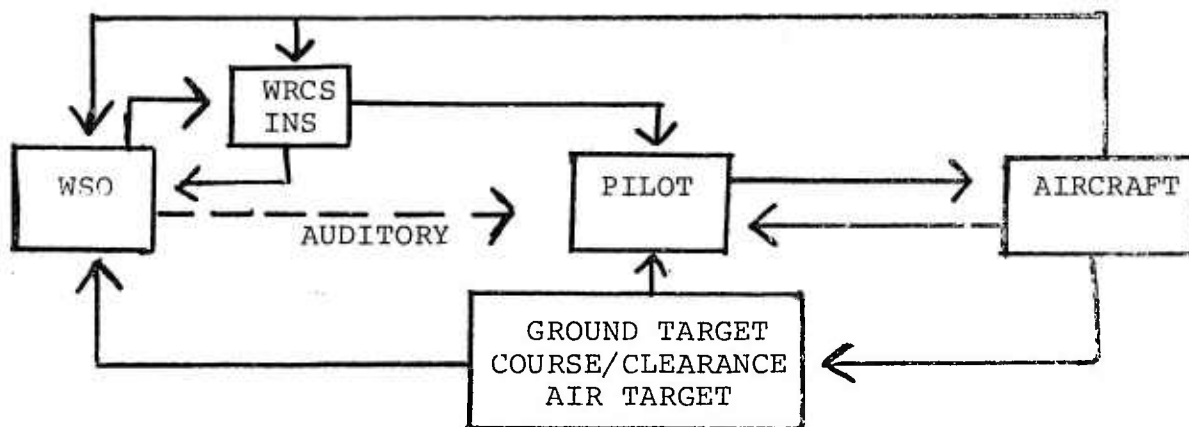

Figure 6. Crew-System Relationships  
Non-Radar Mission

It can be seen that a "parallel" relationship exists in which the pilot is simply provided with additional information from the WSO, who can partially help the pilot control the vehicle. Note that the WSO has access to much information, but does not have control execution authority. Any control he

TABLE IV

## SAMPLE OF WSO TASKS IN A NON-RADAR ENVIRONMENT

PHASE	TASKS
TRANSITION	Flight Instrument Interpretation Basic Aircraft Control Recovery From Unusual Attitudes Checklist Reading Visual Lookout Call Gear, Flaps; Read Altitude, AOA, A/S Monitor Procedures, Fuel State, etc.
INSTRUMENT	Flight Planning, Meterology, DD 175 Interpretation of SID's, Letdown's Charts Correlation of Pubs and Flight Progress + TRANSITION Tasks
FORMATION	Know Hand Signals Inform Pilot of Formation Status Monitor Aircraft Status and Subsystems Judge Distance and Closure Rates + TRANSITION and INSTRUMENT Tasks
ACM	Know Potential g's and Energy Maneuverability Watch AOA and Aileron Input at High AOA Visual Search, Radar and Aircraft Monitoring Describe Opponent's Location and Maneuvers Interpret Opponent's Maneuvers (Some pilots would like corrective action: Reverse, etc.) Radar and Switchology as required + FORMATION, INSTRUMENT and TRANSITION Tasks
GROUND ATTACK	Checklists and Switchology for Each Event Read Altitude, A/S, Attitude as Required Record Vehicle Parameters at Pickle Participate in Error Analysis Visually Track Other Aircraft Monitor g's AOA on Recovery and Entry + FORMATION, INSTRUMENT and TRANSITION Tasks
GROUND ATTACK (TACTICAL)	Basic Visual Navigation, Map Reading Target Recognition Radar for Ranging and $V_C$ as Required + GROUND ATTACK, etc. Tasks
DART FIRING	Coach A/S and Overtake From Radar + FORMATION, etc. Tasks
ALL PHASES	Mental Computations, Rules of Thumb (No Time to use Computer for Navigation)

exercises (of system performance) is through the pilot, primarily through an auditory link, and secondarily through a command steering input to the pilot's instruments through the WRCS. Except for rear seat circuit breaker control, a few switches, radar and navigation items, the pilot could perform his function without the WSO.

In this parallel, ideal copilot role, the WSO reads checklists, provides the pilot with information, performs navigation, operates radios, and monitors the pilot for compliance with clearances, procedures and safety items. To perform effectively, it is apparent that the WSO must know the pilot's job well. The WSO's role in navigation is slightly more active. He has control of the INS, WRCS, radios and radar.

The principal measurement point for WSO performance in the non-radar mission is the auditory link. There is no other way of knowing what the WSO is doing inflight, or the extent to which he knows his job of providing timely and accurate information to the pilot.

Radar mission. During radar-oriented mission phases the role of the WSO is more readily related to overall system performance. Note in Figure 7 that the direct input line from the ground or air target (see Figure 6) to the pilot has been replaced by a visual link with the radar set and the primary auditory link with the WSO:

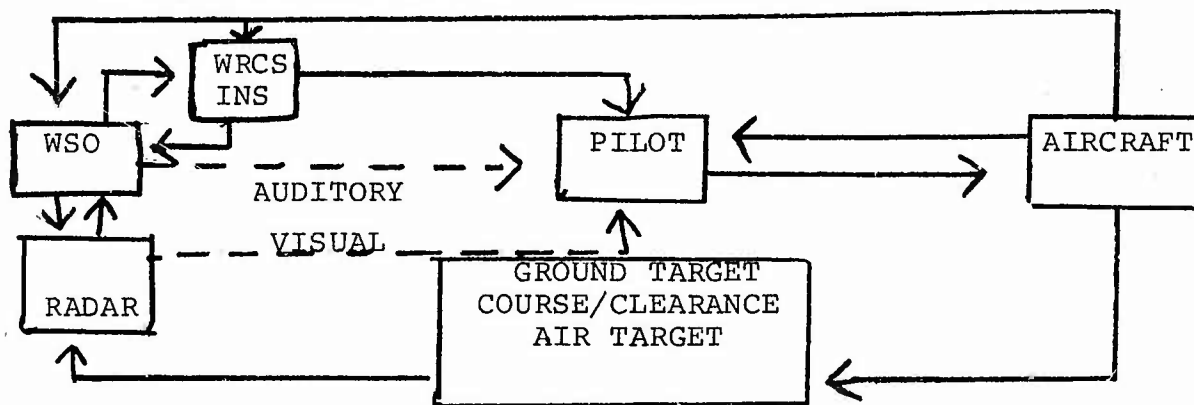

Figure 7. Crew-System Relationships  
Radar Mission

Using radar, the WSO controls the aircraft via auditory commands to the pilot and through command steering inputs to the ADI/HSI as a consequence of WRCS/INS operation and update. The direct relationship between WSO system operation and vehicle or mission performance remains obscured by the pilot-vehicle control relationship. The pilot can make the WSO look good or bad in terms of mission success (and vice-versa).

Switchology, radar setup and radar sub-system operation provide a direct measurement of WSO-Subsystem performance.

Auditory measurement is again required to identify what the WSO is telling the pilot and for additional comparisons of commands the pilot receives and the resulting actions that the pilot takes with the vehicle. Only in the situation where the pilot complies immediately and exactly to WSO commands, will the total system or mission performance reveal WSO proficiency. It is extremely doubtful that the pilot will exactly comply to WSO commands for a variety of sound reasons (such as energy level, fuel state, other information etc.). Therefore, measures of WSO proficiency at the system performance level are confounded.

Approaches to multi-crew measurement. In order to accurately measure an individual's performance, the input stimuli (what he senses) and his output responses (what he does with the information) should be numerically described. In the F-4E situation the pilot controls the aircraft, so assumptions can be made about the pilot's skill based on his input to the aircraft and subsequent aircraft maneuvering. For the WSO, the input stimuli can be specified partially, but except for direct manipulation of his subsystems, his control output is verbal--to the pilot. In order to generate measurement, one must define at least candidate relationships between the two crew members.

Two approaches to defining the relationships between the two crew members appear feasible. One approach is to construct a model of an ideal operator for each crew position and to measure the consequences of known variations of each on system or mission performance by iteratively exercising the models in a computer. It is possible that such an approach would reveal the significant elements of performance for each crewmember, and might serve to reduce the required measurement set to manageable proportions. This approach assumes the existence of sufficient data to construct models. Although there are potentially useful pilot models available as a point of departure, insufficient data have been collected to model the WSO.

The other approach requires a reasonable analysis of the tasks and training situation, followed by construction of candidate measurement sets which will be subjected to empirical testing and revision once sufficient initial and later normative data are collected. Previous experience clearly demonstrates that our analytic tools are insufficiently robust to predict all relevant relationships in complex vehicle training; the combined analytic-empirical approach will succeed if proper flexibility is built into the measurement system for iterative changes.

In relation to the F-4E crew measurement problem, this approach requires measuring all relevant system and subsystem states (called out by analyses) in addition to measuring the auditory link between the two crew members. An enormous amount of data would be generated. These data would have to be sifted

and filtered by research studies. If current training doctrine is observed, it can be anticipated that each crewmember and each crew will operate with a slightly different relationship; crew coordination is largely determined by each aircraft commander, not by doctrine.

It is an inescapable conclusion that measurement of the verbal interchange between the crewmembers is necessary. For active use of the measurement system in training, instructor personnel have indicated a need for a voice track with every conceivable measurement medium. For research purposes, the analysis concludes that only through the measurement of the audio channel(s) can the input and output of each crew member be fully described.

### Communication Analysis

An analysis was undertaken to determine a potential structure for communication data. The analysis first revealed that auditory information transfer must be measured both ways. The pilot could be as guilty as the WSO of providing the wrong information, or untimely information with respect to the other man's job. It is clear that each must know well the other man's job in order to know what information is helpful, and when to provide it. Information exchange provides a method of measuring this knowledge.

Preliminary analyses reveal that the information transfer is not as expansive as one might initially suppose. For most mission situations there is a specific vocabulary and syntax required. Procedures have been standardized to the extent that it is possible to structure auditory measurement. Vocabulary and procedures, and measurement structure will be discussed.

Vocabulary and procedures. During ground attack training the patterns and delivery parameters are standardized. A typical pattern is shown in Figure 8. The mission-related communication requirements are implied by the profile and delivery parameters shown on the charts. For these canned missions, tables of required auditory communications can be constructed. Actual communications can be compared against these tables.

During air-to-air training, the WSO--Pilot command action vocabulary is shown in Table VI. Again, communication tables can be constructed, actual communications compared against the standard vocabulary, and the accuracy of the communication can be compared against the measured aircraft situation at the moment in computer analysis. For directive commentary, the commands given by the WSO to the pilot are finite. The system performance change anticipated as a consequence of each command is stated in Table V, and shown in flowchart form in Figures 9-11. Expected changes in system performance can be tabled in computer analysis and once the time of a particular command is



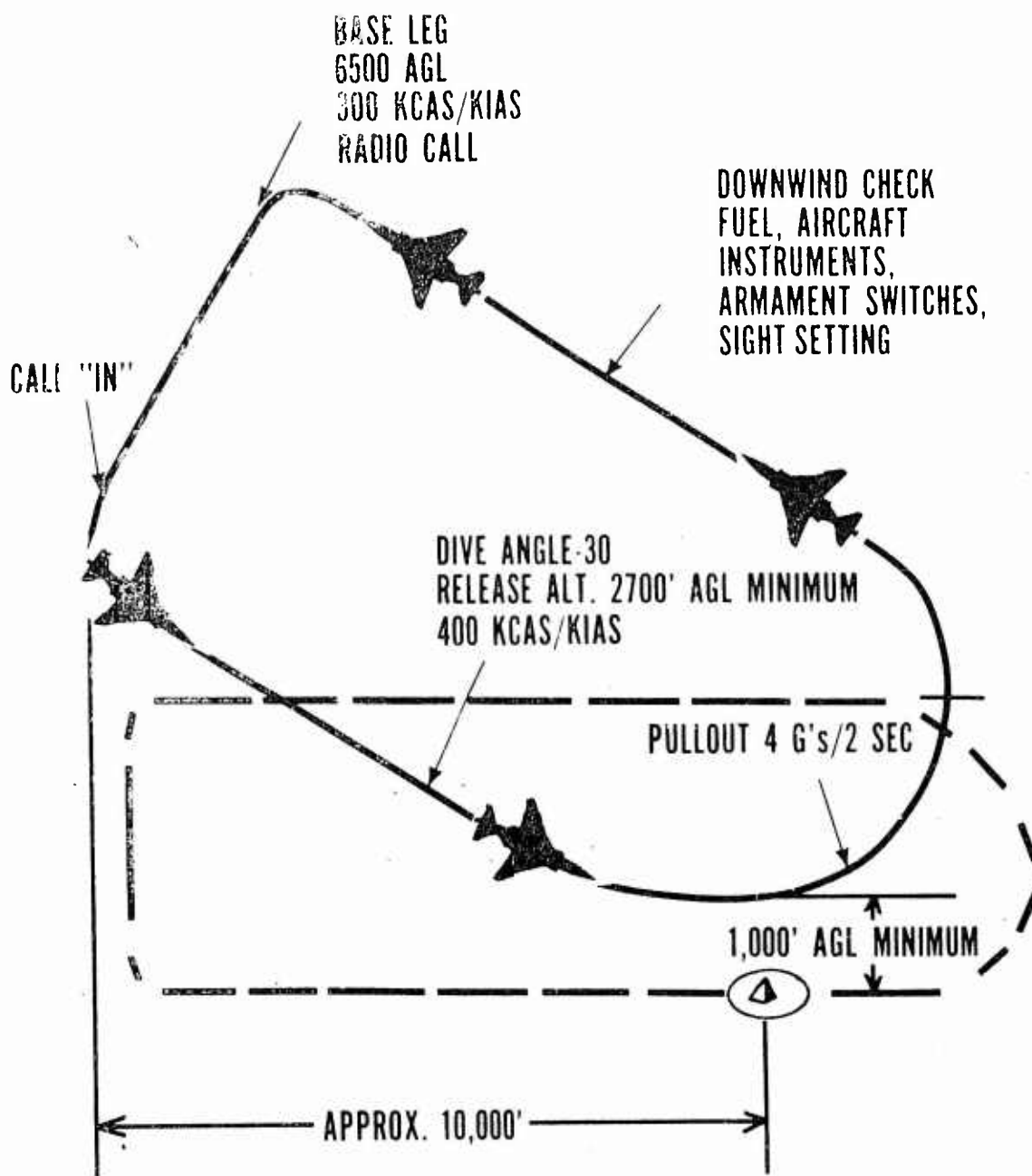

Figure 8. Typical 30° Rocket Pattern.



known, the resultant system performance change can be measured against the command.

Thus, the vocabulary is standard, and the relationship between vocabulary, mission requirements and system performance can be structured for computer analysis.

TABLE V  
DIRECTIVE COMMENTARY

Command	ACTION TO BE TAKEN
a. "Climb"	Climb 1000 FPM maintaining airspeed.
b. "Climb More"	Increase climb 1000 FPM maintaining airspeed.
c. "Hold Climb or Hold Descent"	Maintain present rate of climb or descent.
d. "Go Down"	Descent 1000 FPM maintaining airspeed.
e. "Down More"	Increase rate of descent 1000 FPM maintaining airspeed.
f. "Nose Up"	Maximum rate of descent (not required to maintain airspeed).
g. "Dive"	Maximum rate of descent (not required to maintain airspeed).
h. "Level Off a Little"	Decrease rate of climb or descent 1000 FPM.
i. "Level Off"	Return to level flight; AC replies "Level". (Note: It is possible for the pilot/WSO to give elevation changes for a certain number of feet. AC calls "Level" after correction is completed).
j. "Hold Speed"	Maintain present airspeed (AC replies "Speed set").
k. "Increase"	AC repeats command and increases airspeed as required by pilot/WSO. When speed is attained, AC calls "Speed set".
l. "Throttle Back"	AC repeats command and decreases power as required by pilot/WSO. AC then replies, "Speed set".
m. "Throttle Right Back"	Speedbrakes fully extended; minimum airspeed (AC notified when minimum airspeed is reached).

TABLE V

## DIRECTIVE COMMENTARY (CONTINUED)

Command	ACTION TO BE TAKEN
n. "Easy Port or Starboard"	15° of bank.
o. "Port of Starboard"	30° bank left or right, maintaining airspeed and altitude.
p. "Port or Starboard Hard"	45° left or right maintaining airspeed and altitude.
q. "Harder.....Hold"	Increase degree of bank until pilot/WSO gives "Hold" or until a "Hard as possible" turn is reached. AC notifies pilot/WSO when a maximum rate of turn is reached.
r. "Port of Starboard Hard as Possible"	Maximum degree of bank maintaining airspeed and altitude.
s. "Ease Off"	AC decreases degree of bank until the pilot/WSO gives "Hold" or until aircraft is steady. (AC notifies pilot/WSO when aircraft is steady).
t. "Hold"	Maintain present bank.
u. "Steady"	Return to straight flight.

TABLE VI  
DESCRIPTIVE COMMENTARY

Comment.	MEANING
a. "Azimuth"	Target(s) position in degrees, port or starboard, from the centerline of the radar scope.
b. "Elevation"	Target(s) position in degrees, above or below, from the level marker on the scope.
c. "Range"	Range in miles as indicated.
d. "Overtake"	Overtake in knots as indicated by the Vc gap or estimated from target movement.
4. Other	
a. "Breakaway Heading"	Heading to establish immediately after attack.
b. "Converging Flight"	Exists if the extended flight paths cross in front of both aircraft.
c. "Diverging Flight"	Flight paths other than converging.
d. "Track Crossing Angle"	The angle formed by the extended flight paths any time converging flight exists.
e. "Compass Error"	The difference between the heading of the fighter and the desired heading.
f. "Scope Error"	The difference between the azimuth of the target on the scope and the desired azimuth.
g. "Hold"	Hold fire.
h. "Fox-Trot Control"	Call sign of telemetry site.
i. "Passing Safe"	Call made by IP when passing clear of tow aircraft.
j. "Romeo Number"	Missile serial number (R-0000).

TABLE VI  
 DESCRIPTIVE COMMENTARY (CONTINUED)

Comment	MEANING
k. "Shooter"	Firing aircraft.
l. "F Number"	Telemetry Pack Frequency Designator (F1, F2, F3, F4, or F5).
m. "Dart Firing Series"	One high speed and one low speed firing pass.
n. "Dart Firing Sortie"	One flight sortie - One flight of one aircraft that has completed 2 dart firing series or obtained a hit on the dart.
o. "Target"	Towed TDU-22B, TDU-25B.
p. "Tow"	Tow aircraft.
q. "Clear to Fire"	Used only to indicate clearance to fire.
r. "Nancy Sweet"	Audible high-pitched IR tone.
s. "Nancy Sour"	Inaudible high-pitched IR tone.

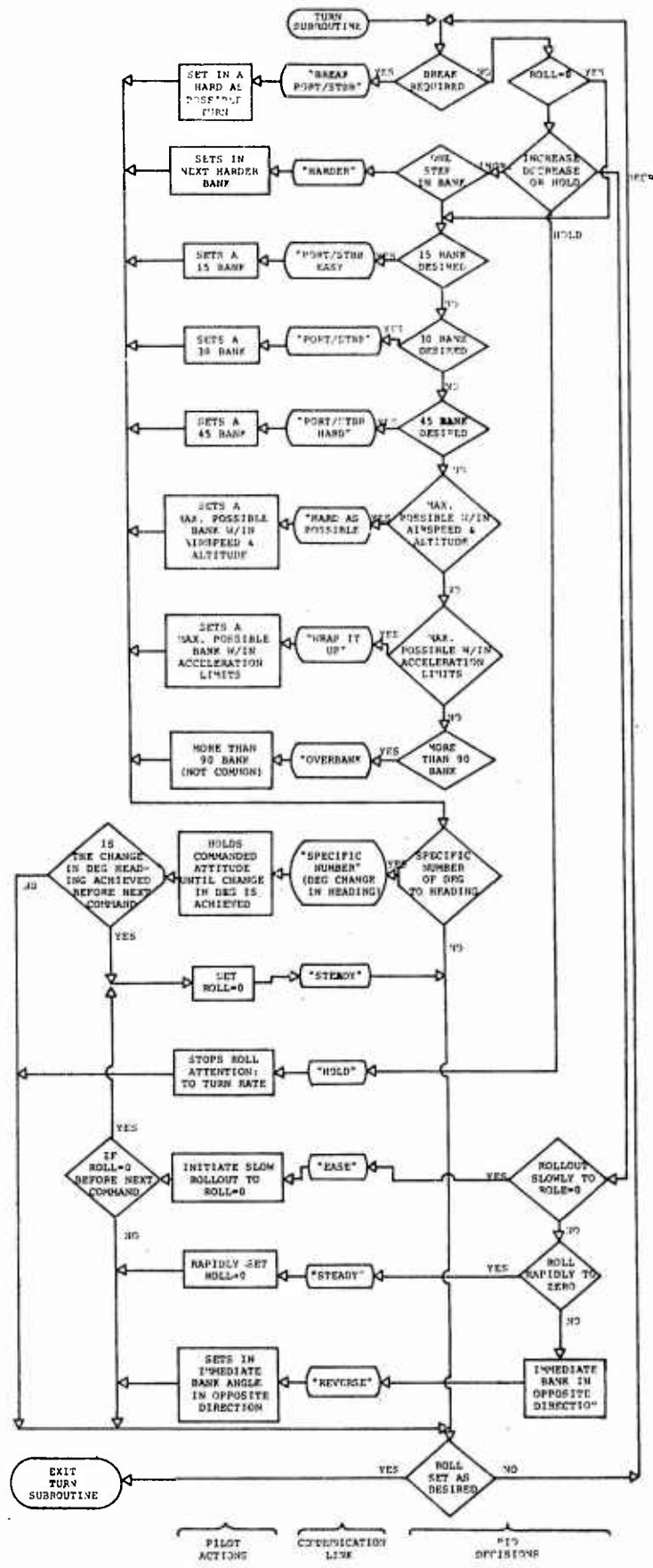

Figure 7. Sample Flow Diagram for Pilot-RIO Communications; Heading and Bank Changes.

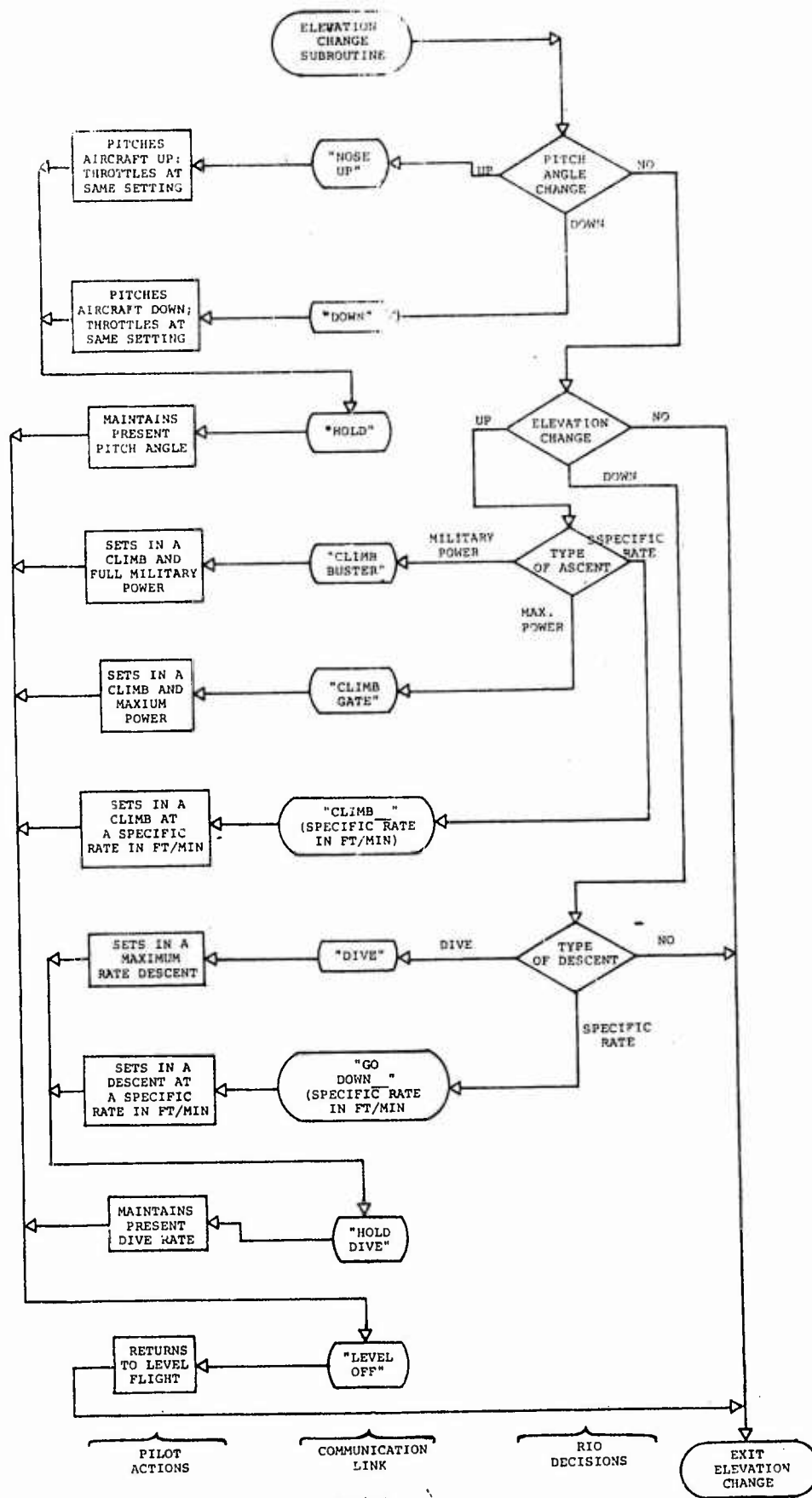

Figure 8. Sample Flow Diagram for Pilot-RIO Communications; Elevation Changes.

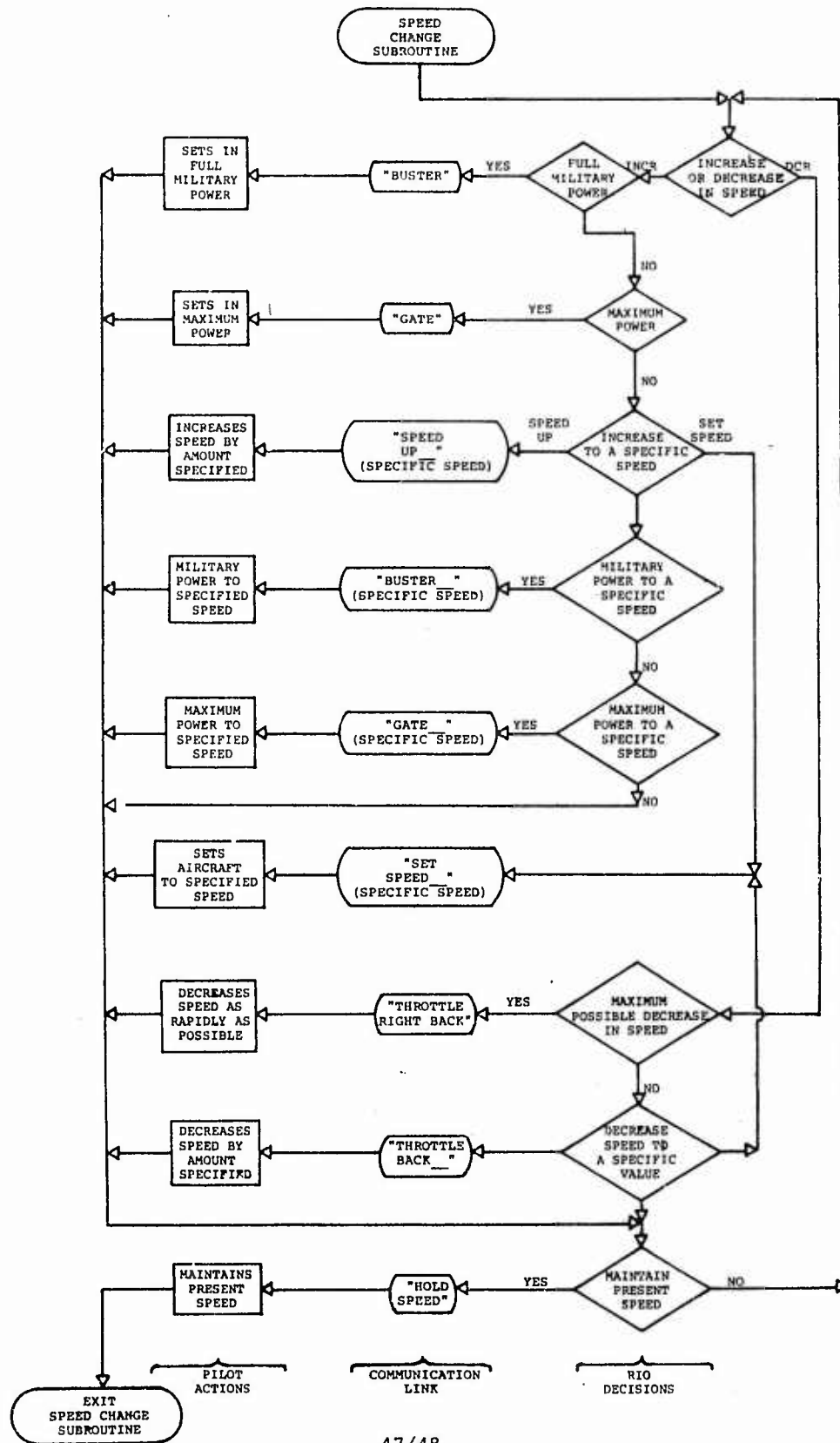

Figure 9. Sample Flow Diagram for Pilot-RIO Communications; Speed Changes.



#### IV. COMMUNICATIONS MEASUREMENT SYSTEM

Since the analysis of crew communications appears to be vital for the investigation of crew interactions and crew performance, the details of such measurement will be expanded upon in the following paragraphs. The analysis of communications presents at least two problems: How does one extract the meaningful information? And, what procedure should be followed so that the information can be identified, standardized, and processed along with information of other forms (e. g., altitude, weapons delivery scores) into a common data base for comprehensive analysis. Therefore, the remainder of this chapter is devoted to identifying the categories of measurement possible, and the details of a candidate communications data system.

##### Measurement Categories

Review of information transfer required of the mission segments being trained reveals six measurement categories, (1) timing, (2) accuracy, (3) brevity, (4) number and frequency, (5) information content, and (6) performance changes as a consequence of communication.

Timing. A frequent problem with the neophyte crewmember is a failure to recognize what is important; he does not know how to place priorities on the information needs of the other crewmembers relative to the flight situation of the moment. Instructor interviews reveal that the student will frequently jam a more important communication with something of less importance at the moment. For example, early in training, the neophyte may read the after take-off checklist at the moment that departure control is changing the flight clearance. Measures of information timing should reveal the following:

- a. Jamming more important messages
- b. Providing information at the wrong time
- c. Delay in providing information
- d. Pacing--providing information at a rate that permits effective response by other crewmember.

Accuracy. Measures of accuracy require the comparison of what is being said relative to the measured situation. Is the bogey at 10 o'clock, or is it at 8 o'clock? Are the instrument readings accurate, or did the crewmember make a 1,000 ft. altimeter reading error? Is the radar interpretation correct? Was the hot-cold side determination made properly?

Brevity. Interviews have all revealed that in combat the radio and interphone traffic far exceeds the channel capacities. In a fight or over a target there can be so much traffic that it is virtually impossible to tell who is saying what to whom. Within the existing structure and communication system of the strike forces, the only action that can be taken is to over-train brevity and to strictly enforce radio discipline. A standard vocabulary has been developed (Operational Brevity

code, Table VII) to relieve congestion. Strict disciplined use of this code should be trained, and measured.

In addition to measures of compliance to the brevity code for standard situations, measures of length of communications should be included in this category. Measures of communication length reflect the student's facility with the brevity code, and provides measurement of non-standard information transfer brevity.

Number and frequency. Closely associated with brevity is the number of communications and the frequency of communications (number per unit time). Analyses of communication frequency have reflected the state of skill acquisition. For example, one study found that crews who were experienced communicated less during routine operation than inexperienced crews. Conversely, however, the experienced crews communicated more frequently during weapons delivery than the inexperienced crews<sup>1</sup>. Recent interviews with IWSO's at George AFB suggested that the number and frequency of communications is an indicator of proficiency. Neophyte WSO's appear to say little until they become more knowledgeable. A training milestone is felt to occur once the WSO starts talking.

Information content. As communication skills improve, the information transmitted per unit of time should reveal skill acquisition. Presumably, a crewmember could transmit less often, but say more (or less) per transmission. Previous research by Siskel, et.al., suggests that information content does not vary; a simple measure of the number of communications suffice. However, it is felt that information content should be measured to insure that other measures are not contaminated by changes in information content.

Performance changes. The end goal of communicating is to affect system performance changes to enhance mission success. When a crewmember other than the pilot is indirectly controlling the mission, then measures should identify if the controller got what he asked for. Similarly, the measures should identify whether or not the controller was asking for a performance change that was reasonable (ie: was the controller expecting the impossible?). System performance measures should relate to the whole auditory measurement set to begin the task of identifying "optimum" auditory communication strategies. The author is aware of no clear criteria for training this skill, other than the concept of "pacing" which is vaguely defined.

---

<sup>1</sup>Siskel, M., Lane, F. D., Powe, W. E., and Flexman, R. E. Intra-Crew Communication of B-52 and KC-135 Students and Combat Crews During Selected Mission Segments. USAF AMRL-TR-65-18, May 1965. (AD 617 598)

TABLE VII  
OPERATIONAL BREVITY CODE

WORD	MEANING
a. "Anchor"	Orbiting a visual orbit point.
b. "Angels"	Altitude in thousands of feet.
c. "Bent"	Equipment indicated inoperative or unserviceable.
d. "Bogey"	Unidentified aircraft.
e. "Buster"	Fly at military power.
f. "Chatter"	Communications jamming.
g. "Chattermark"	Start communications jamming countermeasures.
h. "Check <u>    </u> <sup>o</sup> Port" "Check <u>    </u> <sup>o</sup> Star- board"	Alter heading <u>    </u> degrees left or right momentarily for air-borne radar search and then resume heading.
i. "Chicks"	Friendly fighter aircraft.
j. "Contact"	I have a target on my radar. (Aircrew will call contact with azimuth and range.)
k. "Expedite"	As quickly as possible; hurry up.
l. "Faded"	Contact has faded from ground radar.
m. "Famished"	Have you any instructions for me?
n. "Feet wet"	Aircraft is over water.
o. "FOX I"	AIM-7 deployment.
p. "FOX II"	AIM-9/4 deployment.
q. "Fuel"	Amount of fuel remaining (in pounds). Give tape over counter.
r. "Gadget"	Airborne intercept radar.

TABLE VII  
OPERATIONAL BREVITY CODE (CONTINUED)

WORD	MEANING
s. "Gate"	Fly at maximum possible power.
t. "Heads Up"	Target got through.
u. "Holding Hands"	Aircraft in close formation.
v. "Home Plate"	Home airfield.
w. "Judy"	I am taking over the intercept. (Lock-on not required. Controller will not acknowledge but will cease giving information.)
x. "Level"	Target is at your altitude or I am at assigned altitude.
y. "Liner"	Fly at speed giving maximum cruising range.
z. "M. A."	Mission accomplished.
aa. "MAY DAY"	Distress call.
bb. "M. I."	Missed intercept (for AIM firing, missile was not fired).
cc. "Music"	Electronic jamming.
dd. "Nancy"	Airborne infra-red equipment.
ee. "No Joy"	Cannot find target.
ff. "On the Deck"	At minimum altitude.
gg. "Oranges Sour"	Weather is unsuitable for aircraft mission.
hh. "Oranges Sweet"	Weather is suitable for aircraft mission.
ii. "Orbit"	Circle.
jj. "Pancake"	Land, refuel, re-arm.

TABLE VII  
OPERATIONAL BREVITY CODE (CONTINUED)

WORD	MEANING
kk. "Parrot"	IFF/SIF.
ll. "Pigeons"	The magnetic bearing and distance to home base.
mm. "Popeye"	In clouds or area of reduced visibility.
nn. "Rain"	Chaff.
oo. "Rat" "Rat Fink"	Enemy fighter, Enemy bomber.
pp. "Reno"	Break out between targets.
qq. "Saunter"	Fly at best endurance.
rr. "Skip it"	Do not attack/cease attack or cease intercept and turn to breakaway heading. (For AIM firing - Break off attack and SAFE armament switches).
ss. "Sour"	Equipment indicated in operating at reduced efficiency.
tt. "Splashed"	Target is shot down.
uu. "Steer"	Set magnetic heading indicated.
vv. "Steady"	On prescribed heading.
ww. "Stranger"	Unidentified aircraft. (Aircrew will acknowledge with call sign and either "Contact", "Tallyho", or "No Joy").
xx. "Strangle"	Switch off equipment indicated.
yy. "Sweet"	Equipment indicated is operating efficiently.
zz. "Tallyho"	Aircraft sighted.
aaa. "Tied On"	Radar contact established for in-trail formation.

TABLE VII  
OPERATIONAL BREVIETY CODE (CONTINUED)

WORD	MEANING
bbb. "Vector"	Alter heading to magnetic heading indicated.
ccc. "Visual"	Visual contact.
ddd. "Weapon"	Airbourne intercept radar/ ground radar.
eee. "What Luck?"	What has been the result of assigned mission?
fff. "What State?"	Report amount of fuel (Tape over counter).

In summary, the performance changes of the vehicle as a function of communicating define the end goal of communicating, and define the logical link between auditory data and system or mission performance data.

#### Candidate Communications Data System

A computer assisted, manual auditory data processing system is envisioned. The method assumes that "expert" personnel will participate during initial system development research to generate unambiguous rules of data processing personnel who will operate the system. It is foreseen that multiple passes of properly synchronized audio and parameter recordings may be required as a function of the kind and amount of data that are to be extracted. While listening to and observing synchronized audio-visual, or audio-parameter recordings, the data processor enters events into the computer using known formats and structures. Such events will be the time that maneuvers start, what maneuvers start, what maneuver is requested, and measures of timing, brevity, etc., that have been outlined.

Three problem areas with auditory data have been defined, (1) identification, (2) synchronization and (3) data reduction.

Identification. In the milieu of the communications environment that occur during training, in the simulator and during combat, it is mandatory that the audio channel(s) provide a means of clearly identifying who is talking. The sensors might have to employ voice key circuitry to trigger a digital signal that indicates which crewmember is talking and which channel (ICS or UHF) he is talking on. As a side benefit, these data can be used as a direct measure of jamming.

Synchronization. Audio data must be properly synchronized with all other data media such as video or aircraft or sub-system parameter recording. An auditory functional data processing flowchart (Figure 12) shows five possible sources of auditory data. Because of the operations involved with synchronizing separately recorded audio with either video or parameter recording, it is clear that audio should be synchronized with either video or parameter recording during acquisition. Selection of the video with voice track would be of most benefit to the immediate training application, although there may be other reasons to select the audio-parameter recording method. Finally, it is possible that both video and parameter recording will be incorporated in the measurement system; synchronization between the two must be achieved if they contain related data. Such synchronization should occur during acquisition, if possible.

Data reduction. At least two methods of reducing auditory data can be visualized. The first would require playback of the data by instructor personnel who are qualified to make judgments on the adequacy of the verbal interchange. Scoresheets could be developed for instructors to "grade" each event in terms of



DATA SOURCE

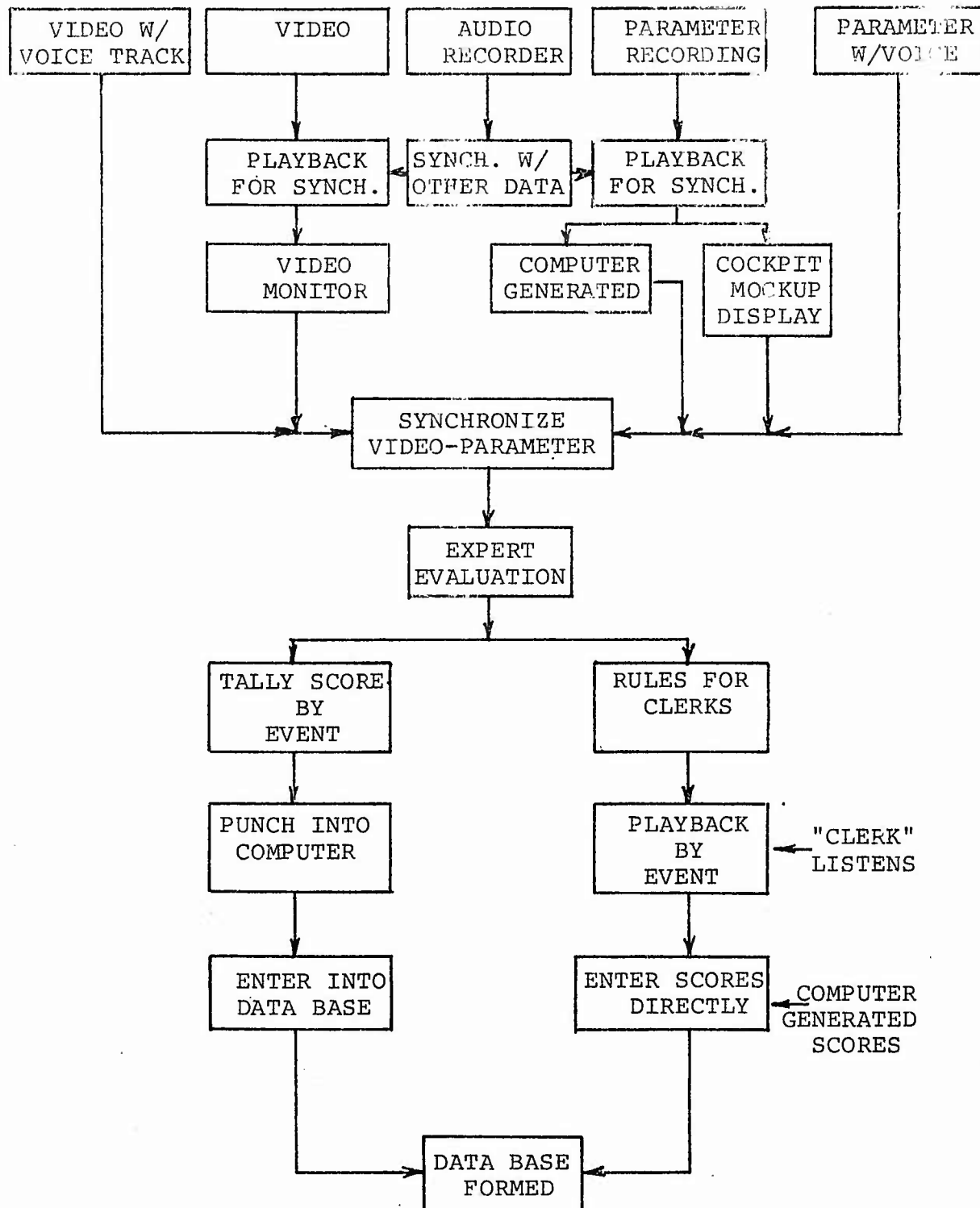

Figure 12. Auditory Functional Data Processing



the auditory measurement categories previously developed. These scores could be entered into the computer data base along with the parameter data. The second method is an out-growth of the first.

The second method assumes that as a consequence of measurement development studies, research personnel and instructor personnel could define the rules for auditory data reduction well enough that data processing personnel could monitor communications and enter required data into a computer. There are many possible schemes; however, one candidate is discussed.

A candidate audio data reduction structure is shown in Table VIII which related the candidate measures with the candidate methods of acquiring those measures, voice key analysis and four special purpose "manual" analyses.

1. Voice Key. Assuming that there must be voice key type of circuitry to identify who is talking, the same signal can indicate the time and length of each message. Computer analyses (automatic) of these signals should be able to provide start/stop information for other analyses (descriptive commentary analyses, information content analyses, and performance change analyses). It is reasonable to assume that once the computer algorithms are improved through iterative testing, measures of jamming, length, number and frequency can be provided without manual intervention.

2. Brevity code analyses. This analysis required a separate sampling of the auditory data by a Data Processor specifically trained in the brevity code and its use. The Processor would mark, or tally in the data computer all mistakes. The rules, of course, remain to be developed.

3. Command following analyses. For air-to-air intercept, low-level radar navigation, and radar navigation bombing, a system is envisioned wherein the Data Processor has discrete entry keys for each of the commands listed in Table V (Directive Commentary). He would play-back synchronized system performance and audio data and key-in the specific commands that were given. The computer could match each entry to the voice key signal (to remove Data Processor reaction time). Additionally, for rapidly executing events, the Data Processor should have control of the system performance-audio data storage media so that he can stop, back-up or otherwise manipulate the data. Following the identification of the command, computer analyses of the response to that command or command string can proceed online or offline.

4. Descriptive commentary analyses. A separate sampling of the system-performance-auditory data is envisioned to determine the accuracy, information timeliness, and resultant performance changes. As presently conceived, this analysis would be conducted by a specially trained Data Processor in

TABLE VIII

## CANDIDATE AUDIO DATA REDUCTION APPROACH

MEASURE	METHOD TO ACQUIRE MEASURE				
	AUTO	MANUAL, COMPUTER ASSISTED			
	VOICE KEY	BREVITY CODE	COMMAND FOLLOWING	DESCRIPTIVE COMMENTARY	INFORMATION CONTENT
TIMING					
Jamming	X				
Wrong time	S			X	
Delayed	S			X	
Pacing	S			X	
ACCURACY	S			X	
BREVITY					
Code usage		X			
Length	X				
NUMBER & FREQUENCY	X				
INFORMATION	S				X
PERFORMANCE CHANGE	S		X	X	

Key: X=Measure provided by analysis method.  
S=Use of method to key start/stop and timing logic.

much the same way that the command following analysis is proposed. During playback, a Data Processor using discrete keys would identify for the computer the descriptive comment that was made. The computer could then in real-time or off-line determine the accuracy, timeliness and performance changes as a consequence of the commentary. For example, if during intercept the WSO called the target at 50 Left, that information would be entered, adjusted to the voice key start time, and a comparison could be made of the actual target position at that time (plus or minus a reasonable tolerance) to determine accuracy. If during ground attack the WSO called the altitude at 10,000-ft., that information would be entered into the computer, adjusted to the voice key start time, and a comparison made of altitude. Much of the information change between the crewmembers falls into this analysis category from Transition through Ground Attack.

5. Information content. Finally, a separate analysis is envisioned to derive information content for each message. While this analysis is to be more fully developed, it appears that rules can be constructed to define a logical information unit, and the content of each transmission should be examined to determine the number of information units.

It is obvious that this candidate data reduction scheme can generate a staggering amount of data. Certainly utility analyses will have to reduce this scheme to a practical one. It is equally possible, however, that structuring a system to do these kinds of analyses will have great general utility, and for any one study judicious scoping and sampling can reduce the problem of too much data.

## V. SUMMARY

One of the main difficulties in performing detailed analyses of crew interactions is the lack of specificity in stating requirements for crew relationships. Crewmembers are trained to perform their individual duties. They then develop methods of coordinating with each other, if ever given sufficient opportunity to work with the same people. The result is that crew coordination is not always developed, and, where it is developed, the methods are nonstandard. Since crew interaction techniques are nonstandard, and specific techniques are not trained, measurement of crew interaction cannot be explicitly defined in most cases.

A further difficulty in analyzing crew interactions is the degree to which the performance of each crewmember is dependent on the performance of the others. For example, in an air drop, the navigator uses reported winds to compute the CARP, he indicates a ground track for the pilot to maintain and times the release (which is physically performed by the copilot). It may be seen that winds, distance, timing, and response times all become involved in the error equation. Unless a gross error is evident, it may not be possible to determine all the sources of error. Without such feedback, it is difficult for the crew to understand where they must improve.

Better methods of crew interaction must be discovered and developed; the best must be identified. Training methods can then be produced, given sufficient definition of the behavioral objectives which must be reached. In short, research is needed to resolve crew training and measurement problems. Some data are needed now to carry the current analysis further. In turn, measurement tools are needed to produce such data. The usual dilemma is with us: If the nature of crew performance were thoroughly understood, specification of measurement would be straightforward; however, measurement is needed to promote greater understanding of the problems. Some tools are necessary, therefore, to promote further knowledge of crew interactions.

Tools for research can be specified. Total crew-system performance measurement will reflect the contributions of each of the crewmembers to the success/failure of the mission. The major inputs and outputs of each crewmember is reflected in this set of measures, except for the interactions between each other. These interactions may be described in terms of specific bits of information gleaned from their verbal communications. Further data may be collected from the pre-mission briefings and special post-mission critiques and interviews.

The collection of these data will involve equipment for recording aircraft signals, visual information from outside the aircraft and the radar screens, and auditory information from the interphone communications. To allow relating information of any given type to any other piece of information, these data should be combined into a common data base format. It is assumed that digital computer processing will be needed to handle the large volumes of data which are anticipated. A method for processing auditory information is developed in this paper since this information is so important to the problem of crew interaction measurement. However, a method for processing data of auditory, visual, or time-varying parameters, must be developed to cope with the entire measurement problem.