

UNCLASSIFIED

AD NUMBER

ADB000946

LIMITATION CHANGES

TO:

Approved for public release; distribution is unlimited.

FROM:

Distribution authorized to U.S. Gov't. agencies only; Test and Evaluation; OCT 1974. Other requests shall be referred to Air Force Materials Laboratory, Nonmetallic Materials Division, Elastomers and Coatings Branch, Attn: AFML/MBE, Wright-Patterson AFB, OH 45433.

AUTHORITY

AFWAL ltr, 3 Nov 1983

THIS PAGE IS UNCLASSIFIED

AD B000946

AUTHORITY: AFWAL Notice, 3 Nov 83



L

AFML-TR-73-90

Part II

AD B 0 0 0 9 4 6

# LONG LIFE ELASTOMERIC AIRCRAFT HYDRAULIC SEALS

*PARKER HANNIFIN CORPORATION  
SYSTEMS DIVISION & SEAL GROUP*

OCTOBER 1974

FINAL REPORT COVERING PERIOD 15 FEBRUARY 1973 to 15 MARCH 1974

Distribution limited to U.S. Government agencies only; test and evaluation. October 1974. Other requests for this document must be referred to Air Force Materials Laboratory, Nonmetallic Materials Division, Elastomers and Coatings Branch, AFML/MBE, Wright-Patterson Air Force Base, Ohio 45433.

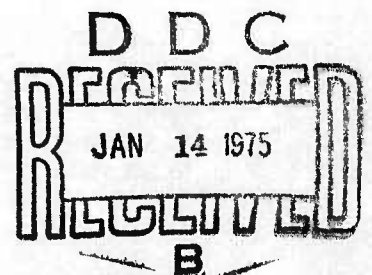

AIR FORCE MATERIALS LABORATORY  
AIR FORCE SYSTEMS COMMAND  
WRIGHT-PATTERSON AIR FORCE BASE, OHIO 45433

NOTICE

When Government drawings, specifications, or other data are used for any purpose other than in connection with a definitely related Government procurement operation, the United States Government thereby incurs no responsibility nor any obligation whatsoever; and the fact that the government may have formulated, furnished, or in any way supplied the said drawings, specifications, or other data, is not to be regarded by implication or otherwise as in any manner licensing the holder or any other person or corporation, or conveying any rights or permission to manufacture, use, or sell any patented invention that may in any way be related thereto.

Copies of this report should not be returned unless return is required by security considerations, contractual obligations, or notice on a specific document.

This final report was submitted by Parker-Hannifin Corp., Irvine, California under Contract F33615-73-C-5122, Job Order Number 73400532, with the Air Force Materials Laboratory, Wright-Patterson Air Force Base, Ohio. R. E. Headrick (MBE) was the laboratory project monitor.

This technical report has been reviewed and is approved for publication.

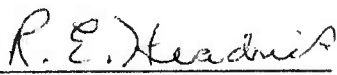
  
R. E. Headrick  
Project Monitor

FOR THE COMMANDER

  
Merrill L. Minges, Chief  
Elastomers and Coatings Branch  
Nonmetallic Materials Division

## UNCLASSIFIED

SECURITY CLASSIFICATION OF THIS PAGE (When Date Entered)

REPORT DOCUMENTATION PAGE		READ INSTRUCTIONS BEFORE COMPLETING FORM
1. REPORT NUMBER AFML-TR-73-90, Part II	2. GOVT ACCESSION NO.	3. RECIPIENT'S CATALOG NUMBER
4. TITLE (and Subtitle) LONG LIFE ELASTOMERIC AIRCRAFT HYDRAULIC SEALS		5. TYPE OF REPORT & PERIOD COVERED Final Report 15 Feb 73 - 15 Mar 74
		6. PERFORMING ORG. REPORT NUMBER
7. AUTHOR(s) K. R. Miller K. T. Ksieski L. G. Hiltner		8. CONTRACT OR GRANT NUMBER(s) F33615-73-C-5122
9. PERFORMING ORGANIZATION NAME AND ADDRESS Parker Hannifin Corporation Systems Division 18321 Jamboree Blvd., Irvine, California 92664		10. PROGRAM ELEMENT, PROJECT, TASK AREA & WORK UNIT NUMBERS Project: 7340 Task: 734005
11. CONTROLLING OFFICE NAME AND ADDRESS Air Force Materials Laboratory Air Force Systems Command Wright-Patterson AFB, Ohio 45433		12. REPORT DATE October 1974
		13. NUMBER OF PAGES 158
14. MONITORING AGENCY NAME & ADDRESS (if different from Controlling Office)		15. SECURITY CLASS. (of this report) UNCLASSIFIED
		15a. DECLASSIFICATION/DOWNGRADING SCHEDULE NA
16. DISTRIBUTION STATEMENT (of this Report) Distribution limited to U.S. Government agencies only; test and evaluation. October 1974. Other requests for this document must be referred to Air Force Materials Laboratory, Nonmetallic Materials Division, Elastomers and Coatings Branch, AFML/MBE, Wright-Patterson Air Force Base, Ohio 45433.		
17. DISTRIBUTION STATEMENT (of the abstract entered in Block 20, if different from Report)		
18. SUPPLEMENTARY NOTES		
19. KEY WORDS (Continue on reverse side if necessary and identify by block number) Hydraulic O-Ring Seals Long Life Fluorocarbon Elastomer Dynamic Testing Backup Rings		
20. ABSTRACT (Continue on reverse side if necessary and identify by block number) The continued development work of long life elastomeric hydraulic seals for -65°F to +450°F/4000 psig service has shown very encouraging results. By optimizing compounds, which were based on commercially available elastomers, it has been possible to meet several goals within this temperature range. Dynamic evaluations which were designed to test specific temperature range have shown:  1. Acrylonitrile compounds have been developed for long service life in MIL-H-5606B fluid over a temperature range of -65°F to +275°F.		

UNCLASSIFIED

SECURITY CLASSIFICATION OF THIS PAGE(When Data Entered)

2. Acrylonitrile compounds have been developed for long service life in MIL-H-83282 fluid over a temperature range of -40°F to +275°F. These compounds have a minimal 100% improvement in dynamic service life over present MIL-P-25732 compounds.

3. Polyacrylates show good potential for a service temperature range of -40°F to +325°F in MIL-H-83282 fluid. Some potential limitations require further investigation in this area.

4. Available fluorocarbon elastomer compounds fabricated into hydraulic O-ring seals have been shown to have long life sealing capabilities over a -10°F to +350°F temperature. At 400°F the life of these seals are less than 1000 hours.

Initial results indicate that greatly improved broad temperature range seals can be developed through compound improvement of the low temperature experimental fluorocarbon elastomers by increasing extrusion resistance and reducing high temperature compression set. This approach coupled with the development of improved anti-extrusion devices will be investigated under future programs.

UNCLASSIFIED

SECURITY CLASSIFICATION OF THIS PAGE(When Data Entered)

## FOREWORD

This report was prepared by Parker Hannifin Corporation, Systems Division, Irvine, California, and Parker Seal Company, Research & Development Laboratory, Culver City, California, under USAF Contract F33615-73-C-5122. The contract work was performed under Project 7340, "Nonmetallic and Composite Materials," Task No. 734005, "Elastomeric and Compliant Materials," and was administrated under the direction of Nonmetallic Materials Division, Air Force Materials Laboratory, Air Force Systems Command, Wright-Patterson Air Force Base, Ohio, with Mr. R. E. Headrick as Project Engineer. Prior development work under this program area was reported in AFML-TR-72-66 and AFML-TR-73-90. This report covers a period of work from 15 February 1973 to 15 February 1974.

## SUMMARY

The continued development work of long life elastomeric hydraulic seals for  $-65^{\circ}\text{F}$  to  $+450^{\circ}\text{F}/4000$  psig service has shown very encouraging results. By optimizing compounds, which were based on commercially available elastomers, it has been possible to meet several goals within this temperature range. Dynamic evaluations which were designed to test specific temperature range have shown:

1. Acrylonitrile compounds have been developed for long service life in MIL-H-5606B fluid over a temperature range of  $-65^{\circ}\text{F}$  to  $+275^{\circ}\text{F}$ .

2. Acrylonitrile compounds have been developed for long service life in MIL-H-83282 fluid over a temperature range of  $-40^{\circ}\text{F}$  to  $+275^{\circ}\text{F}$ . These compounds have a minimal 100% improvement in dynamic service life over present MIL-P-25732 compounds.

3. Polyacrylates show good potential for a service temperature range of  $-40^{\circ}\text{F}$  to  $+325^{\circ}\text{F}$  in MIL-H-83282 fluid. Some potential limitations require further investigation in this area.

4. Available fluorocarbon elastomer compounds fabricated into hydraulic O-ring seals have been shown to have long life sealing capabilities over a  $-10^{\circ}\text{F}$  to  $+350^{\circ}\text{F}$  temperature. At  $400^{\circ}\text{F}$ , the life of these seals are less than 1000 hrs.

Initial results indicate that greatly improved broad temperature range seals can be developed through compound improvement of the low temperature experimental fluorocarbon elastomers by increasing extrusion resistance and reducing high temperature compression set. This approach coupled with the development of improved anti-extrusion devices will be investigated under future programs.



## TABLE OF CONTENTS

		<u>Page</u>
Section I.	INTRODUCTION	1
Section II.	SUMMARY AND CONCLUSIONS	3
Section III.	DEVELOPMENT OF HYDRAULIC SEAL MATERIALS	8
III-1	Development of Acrylonitrile Compounds	9
III-2	Non-Extractable Antioxidants in Acrylonitrile Polymers	11
III-3	Recommended Acrylonitrile Compounds for Field Evaluations	16
III-4	Fluorocarbon Compounds	16
III-5	Compression Set Resistance of Fluorocarbon Compounds at Elevated Temperatures	18
III-6	Polyacrylate Compounds	20
III-7	Phosphazine Compounds	21
Section IV.	DYNAMIC EVALUATION OF HYDRAULIC SEAL MATERIALS	23
IV-1	Chew Test Evaluations and the Evaluation of Back-up Systems	23
IV-1-a	Chew Test Evaluation of T-Seals	27
IV-2	Evaluation of Seal Materials on the Rod Test Rig	34
IV-2-a	Evaluation of AFE-XN1925-25 and AFE-XN1925-33 in MIL-H-5006B/3000 psig, 275°F	34
IV-2-b	Evaluation of AFE-XN1925-33 in MIL-H-83282/4000 psig/275°F	37
IV-2-c	Evaluation of AFE-XV1836-10 in MIL-H-83282/4000 psig/275°F	37
IV-2-d	Evaluation of Parker Compound V747-75 at 350°F 4000 psig/ Using Cast-Iron/Revonoc 18158 Back-ups	38

TABLE OF CONTENTS  
(con't)

		<u>Page</u>
IV-2-e	Evaluation of Parker Compound V720-75 T-seals at 350°F Using Cast-Iron/Revonoc 18158 Back-ups	39
IV-2-f	Evaluation of Parker Compound V747-75 at 450°F, 4000 psig Using Cast-Iron/Revonoc 18158 Back-ups	39
IV-2-g	Evaluation of AFE-XA1969-56 at 325°F, 4000 psig Using Cast-Iron/Revonoc 18158 Back-ups.	41
IV-3	Evaluation of Seal Materials on the Piston Test Rig	41
IV-3-a	Evaluation of MIL-P-25732B Compound N304-7	42
IV-3-b	The Low Temperature Sealing Limits of Fluoro-carbon Compound.	43
IV-3-c	Evaluation of AFE-XN1925-33 in MIL-H-5606B/3000 psig/275°F Using Revonoc 18158 Back-ups	45
IV-3-d	Evaluation of Parker Compound V747-75 in MIL-H-83282 Fluid, 350°F, 4000 psig, Using Cast-Iron/Revonoc 18158 Back-ups	45
IV-3-e	Evaluation of Parker Compound V747-75 in MIL-H-83282 Fluid, 450°F, 4000 psig Using Cast-Iron/Revonoc 18158 Back-ups	47
IV-3-f	Evaluation of Intermediate Ring to Reduce Extrusion on High Temperature, High Pressure Systems	47
IV-3-g	Evaluation of Parker Compound V747-75 at 400°F in MIL-H-83282, 4000 psig Using Cast-Iron/Revonoc 18158 Back-ups	48

TABLE OF CONTENTS  
(con't)

LIST OF TABLES

	<u>Page</u>
Nos. I, I-A      Acrylonitrile Compounds: AFE-XN1925-33, AFE-XN1925-43, AFE-XN1925-44	50
II, II-A        Acrylonitrile Compounds: AFE-XN1925-45, AFE-XN1925-46, AFE-XN1925-47	52
III, III-A      Acrylonitrile Compounds: AFE-XN1925-48 AFE-XN1925-49, AFE-XN1925-50	54
IV, IV-A        Acrylonitrile Compounds: AFE-XN1925-51, AFE-XN1925-52, AFE-XN1925-53	56
V, V-A          Acrylonitrile Compounds: AFE-XN1925-54, AFE-XN1925-55, AFE-XN1925-56	58
VI, VI-A        Acrylonitrile Compounds: AFE-XN1925-57, AFE-XN1925-58, AFE-XN1925-59	60
VII, VII-A      Acrylonitrile Compounds: AFE-XN1925-60, AFE-XN1925-48, AFE-XN1925-63	62
VIII, VIII-A    Acrylonitrile Compounds: AFE-XN1925-48, AFE-XN1925-61, AFE-XN1925-62	64
IX              Fluid Aging in MIL-H-5606B @ 275°F Followed by Air Aging @ 275°F - Compound AFE-XN1925-48	66
X                Fluid Aging in MIL-H-5606B @ 275°F Followed by Air Aging @ 275°F - Compound AFE-XN1925-61	67
XI               Fluid Aging in MIL-H-5606B @ 275°F Followed by Air Aging @ 275°F - Compound AFE-XN1925-62	68
XII              Fluid Aging in MIL-H-5606B @ 275°F Followed by Air Aging @ 275°F - Volume Change - Compounds AFE-XN1925-48, AFE-XN1925-61, AFE-XN1925-62	69
XIII             Fluorocarbon Compounds: AFE-XV1836-7, AFE-XV1836-9, AFE-XV1836-10, AFE-XV1836-11	70
XIV              Compression Set Resistance of Fluorocarbon Compounds at Elevated Temperatures in Air and MIL-H-83282 Fluid	71
XV, XV-A        Polyacrylate Compounds: AFE-XA2016-1, AFE-XA2016-2, AFE-XA2016-3, Parker Compound A607-7	72
XVI, XVI-A      Polyacrylate Compounds: AFE-XA1969-47, AFE-XA1969-48, AFE-XA1969-56	74
XVII, XVII-A    Phosphazine Compounds: AFE-XZ2046-2, AFE-XZ2046-5, AFE-XZ2046-6	76

**TABLE OF CONTENTS**  
**(con't)**

<u>SECTION VI.</u>	<u>APPENDIXES</u>	<u>Page</u>
APPENDIX I.	News Release from Wright Patterson AFB "Improved Hydraulic Seals"	78
II.	O-Ring Technical Bulletin - "New Development in Long Life Nitrile Seals for Hydraulic Systems"	81
III.	Report 03-257 Rev. A - "Development of the Back-up Rings for High Pressure, High Temperature Seals"	89
IV.	Report 03-258 "Dynamic Rod Seal Evaluation Compound AFE-XN1925-25 and AFE-XN1925-33 in MIL-H-5606B/ 3000 psig/275°F"	94
V.	Report 03-258 Addendum I - "Evaluation of AFE-XN1925-33 in MIL-H-83282/4000 psig/275°F"	112
VI.	Report 03-258 Addendum I - "Evaluation of AFE-XV1836-10 in MIL-H-83282/4000 psig/275°F"	113
VII.	Report 03-258 Addendum II - "Evaluation of Parker Compound V747-75 at 350°F/4000 psig/Using Cast- Iron/Revonoc 18158 Back-ups"	114
VIII.	Report 03-258 Addendum III - "Evaluation of Parker Compound V747-75 at 450°F/4000 psig/Using Cast- Iron/Revenoc 18158 Back-ups"	118
IX.	Report 05-249 Addendum III "Evaluation of MIL-P-25732B Compound N304-7 and Short Term Evaluation of AFE-XV1836-2, AFE-XV1836-7, AFE-XV1836-10, AFE-XV1836-11 and AFE-VS-35"	123
X.	Report 05-249 Addendum IV "Evaluation of AFE-XN1925-33 in MIL-H-5606B/3000 psig/275°F Using Revenoc 18158 Back-ups"	128
XI.	Report 05-249 Addendum V and VI "Evaluation of Parker Compound V747-75 in MIL-H-83282 Fluid, 350°F, 4000 psig/Using Cast-Iron/Revenoc 18158 Back-ups"	129
XII.	Report 05-249 Addendum VII "Investigation of the Revenoc 18158/Cast-Iron Back-up System at 450°F. Review of the Results of Tests Performed at 275°F, 350°F and 450°F."	142

TABLE OF CONTENTS  
(con't)

	<u>Page</u>
APPENDIX XIII. Report 05-249 Addendum VIII "Evaluation of Intermediate Ring to Reduce Extrusion on High Temperature, High Pressure Systems"	149
XIV Report 05-249 Addendum IX "Evaluation of Parker Compound V747-75 at 400°F in MIL-H-83282, 4000 psig Using Cast-Iron/Revenoc 18158 Back-up	154

LIST OF ILLUSTRATIONS

	<u>Page</u>
Elongation vs MIL-H-5606B Aging at 275°	14
Tensile vs MIL-H-5606B Aging at 275°	15
Compression Set Resistance of Fluorocarbon Compounds at Elevated Temperatures in Air and MIL-H-83282 Fluid	19
V747-75 T-Seal with Standard Revonoc 18158 Back-ups	28
V747-75 T-Seal 30,600 cycles 350°F/4000 psig	28
V720-75 T-Seal with Standard Revonoc 18158 Back-ups	29
V720-75 T-Seal with Standard Revonoc 18158 Back-ups	29
V720-75 T-Seal with Standard Revonoc 18158 Back-ups	30
V720-75/Revonoc 18158 in 0.304" Groove	30
V720-75/Revonoc 18158 in 0.304" Groove	31
V720-75 T-Seal in 0.304" Groove Using Combined Brass/Revonoc 18158 Back-up System	32
V720-75 T-Seal in 0.304" Groove Using Combined Brass/Revonoc 18158 Back-up System	32
V720-75 Single T-Seal in 0.304" Groove Using Cast-Iron Spacer/Back-up and Revonoc 18158 Back-up	33
V720-75 Single T-Seal in 0.304" Groove Using Cast-Iron Spacer/Back-up and Revonoc 18158 Back-up	33
V720-75 Single T-Seal in 0.304" Groove Using Cast-Iron Revonoc Spacer Back-ups Plus Revonoc 18156 T-Seal Back-ups	34
N304-7 Cross Section 2-214 O'ring after 754 Hours Service at 275°F on Rod Test Rig	36
AFE-XN1925-33 (N756-75) Cross Section 2-214 O'ring after 1000 Hours Service at 275°F on Rod Test Rig	36

SECTION I

INTRODUCTION

In Technical Reports AFML-TR-72-66 and AFML-TR-73-90 the basic problem of elastomeric seals which are qualified to the MIL-P-25732B specification have been discussed in detail.

The increasing temperature requirements of hydraulic systems have resulted in unsatisfactory performance from this type of material. The frequency of failure has emphasized the need for a "true" Type II - 65°F to +275°F compound.

The introduction of the new MIL-H-83282 fluid with its -40°F to approximately +450°F service range has further complicated the requirements. Present QPL materials, which swell in MIL-H-5606B fluid, have been found to shrink in MIL-H-83282 fluid. For maximum flexibility of fluid usage it is necessary for the new material to function satisfactorily in both media.

Systems designed for MIL-H-83282 fluid with its improved high temperature properties could well exceed the upper temperature limits of present acrylonitrile polymers. Fluorocarbon elastomers have been found to be suitable, but their general use has been limited by their low temperature performance.

Higher pressures have also added more stringent requirements on dynamic seals. Systems which were once 1500 psi or 3000 psi now exceed 4000 psi. This, combined with the increasing service temperatures, has made it necessary for extensive studies in methods of protecting the primary seal.

Earlier studies have been concentrated on the present materials and the development of reliable test methods for evaluation of seals in both rod and piston designed equipment. The unpredicted low temperature sealing of some materials on the rod test rig lead to the development of the piston system. On both test rigs baselines have been determined with MIL-P-25732 QPL compounds to establish the service life at 275°F.

The present program, which is discussed in the report has been designed to continue the development studies of the acrylonitrile polymers which produced very encouraging results at 275°F and to investigate higher temperature and pressure systems.

The Systems Division of the Parker-Hannifin Aerospace Group has been responsible for managing this contract and the manufacture of test equipment. The Parker Seal Company, Research and Development Laboratory has been responsible for the compound development, dynamic functional evaluation and the writing of this report.



The ultimate objective of the development of "Long Life Elastomeric Hydraulic Seals" has been to develop a material which will be suitable for advanced aircraft systems over a temperature range of  $-65^{\circ}\text{F}$  to  $+450^{\circ}\text{F}$  with pressures up to 4000 psi.

In earlier studies it has been established that this universal material is not available and may take many more years to develop. The approach in this development program has been to concentrate on commercially available polymers or polymers which are approaching commercial status. Optimum compounds are developed from these polymers.

The study of the service life of each of these classes of compounds has been evaluated on the dynamic test equipment. These test programs have been designed to segment the ideal temperature range of  $-65^{\circ}\text{F}$  to  $+450^{\circ}\text{F}$ . From a basic knowledge of these materials and a study of the laboratory aging studies and dynamic screening tests, it has been possible to approximate the service capability of each class of elastomer.

Acrylonitrile compounds, which have been used extensively in military aircraft hydraulic systems, have been evaluated over the  $-65^{\circ}\text{F}$  to  $+275^{\circ}\text{F}$  temperature range of the MIL-P-25732 specification.

Other acrylonitrile compounds which were developed for service in MIL-H-83282 fluid have been evaluated over a  $-40^{\circ}\text{F}$  to  $+275^{\circ}\text{F}$  temperature range.

The next increment in the temperature scale was  $-40^{\circ}\text{F}$  to  $+325^{\circ}\text{F}$ . In this range the suitability of polyacrylate polymers in MIL-H-83282 fluid permitted investigation in this area.

For temperatures exceeding  $325^{\circ}\text{F}$  the only polymer class available appears to be fluorocarbons. Dynamic studies have been made at  $350^{\circ}\text{F}$ ,  $400^{\circ}\text{F}$  and  $450^{\circ}\text{F}$  using MIL-H-83282 fluid at 4000 psi. Further dynamic evaluations have been designed to study the low temperature sealing properties of fluorocarbons.

As temperatures and pressures have been increasing, the function of the total composite seal package; seal material, seal design, anti-extrusion device and groove dimensions, has become more critical. Low pressure systems and systems using non-filled Teflon back-up rings are not suitable for these more stringent conditions. Extensive studies have been made, in conjunction with primary seal evaluations, with back-up systems for service temperatures ranging from  $+275^{\circ}\text{F}$  to  $+450^{\circ}\text{F}$ .

The seal design in previous studies of hydraulic seals has been limited to the conventional O-ring. Limited studies of T-seals, which are becoming important in applications where spiral failure of O-rings is a problem, have been investigated in the present program.

## CONCLUSIONS

The development work discussed in this report has shown encouraging results. Many successful dynamic evaluations have illustrated the improvements achieved with the compounds developed under this contract.

Among the successful dynamic tests were:

- (i) Acrylonitrile Compound AFE-XN1925-33 which completed 1000 hour tests in MIL-H-5606B and MIL-H-83282 fluids, -65°F to +275°F, 50 - 3000 psig on both piston and rod test rigs. This compound is recommended for field evaluation in Type II hydraulic systems.
- (ii) Acrylonitrile Compound AFE-XN1925-33 also passed similar tests when the pressure was increased to 4000 psig.
- (iii) Acrylonitrile Compound AFE-XN1925-25, which was designed for MIL-H-83282 fluid, has completed 1000 hour tests for -40°F to +275°F service.
- (iv) A comparison of AFE-XN1925-33 and AFE-XN1925-25 with present MIL-P-25732 QPL compounds has clearly shown a minimal 100% improvement in service life at 275°F.
- (v) Fluorocarbon Compound AFE-XV1836-10 successfully completed 1000 hours in MIL-H-83282 at 275°F, 50 - 4000 psig on the rod test rig. The low temperature limits on the rod evaluation were -65°F but later tests on piston rig confirmed a "true" sealing limit of -10°F to -20°F.

- (vi) Parker Fluorocarbon Compound V747-75 successfully completed 1000 hour tests on both piston and rod rigs, 50 - 4000 psig, in MIL-H-83282 fluid at 350°F. The recommended low temperature limits for dynamic applications are between -10°F and -20°F.
  
- (vii) At higher temperatures the service life of Parker Compound V747-75 is limited to less than 1000 accumulated hours at temperature. Seal failure occurred after 700 hours at 400°F and 370 hours at 450°F. The high temperature limitation was a factor of both the compression set of the compound and the design of the anti-extrusion "back-up" system.
  
- (viii) Polyacrylate Compound AFE-XA1969-56 passed a 1000 hour test on the rod rig using MIL-H-83282 fluid, 50 - 4000 psig at 325°F.
  
- (ix) The study of back-up systems has been found to be a critical function in the design of high temperature/high pressure hydraulics. The degree of importance of the material, the design and the dimensions increases with the severity of the temperature and the pressure.
  
- (x) Up to 275°F/4000 psig modified TFE back-up materials have functioned successfully throughout the 1000 hour service life evaluations. Virgin TFE is not acceptable under these conditions.

- (xi) In systems tested at 350°F and higher temperatures the design and dimensions of the back-up system are critical. With careful consideration to the above, a system of a cast-iron ring to reduce the extrusion gap, plus a sacrificial modified TFE back-up material, were successfully designed and tested at 350°F and higher temperatures. The selection of type of material and design of the back-up system can seriously limit the service life of the primary seal.
- (xii) Acrylonitrile compounds developed in this program have clearly illustrated the vast improvement over present MIL-P-25732 Specification compounds. The importance of the balance of dynamic wear resistance and aging characteristics have been illustrated. The lowest compression set resistance does not necessarily mean the best dynamic compound.
- (xiii) Fluorocarbon compounds have been shown to have excellent service life over a temperature range of -10°F to 350°F. At 400°F and 450°F compression set resistance and adequate extrusion protection is a limiting factor on the service life.
- (xiv) Polyacrylates have shown promising properties in MIL-H-83282 fluid at temperatures up to 325°F.
- (xv) Phosphonitrilic fluoroelastomers appear to have similar limitation to fluorosilicones in the area of dynamic properties.

In technical reports AFML-TR-72-66 and AFML-TR-73-90 detailed studies were reported in which the problems of elastomeric seals in aircraft hydraulic systems were discussed.

The high temperature aging of MIL-P-25732B materials results in excessive compression set and hardening of the seal surface in contact with the dynamic metal surface. This, plus the extraction of low temperature plasticizers, which are required to meet the -65°F service requirements, result in frequent failure in "true" Type II -65°F to +275°F hydraulic systems.

Studies with MIL-P-25732B materials were used to establish a comparative baseline for the compound developments on both rod and piston assemblies. Service life in MIL-H-5606B fluid at +275°F was established.

It was concluded in AFML-TR-73-90 that an acrylonitrile compound could be developed to meet the service requirements of MIL-P-25732B - 1000 accumulated hours at +275°F in MIL-H-5606B with frequent -65°F start-up conditions on both rod and piston assemblies being the established goal of the study. Furthermore, acrylonitrile compounds could be specifically developed for -40°F to +275°F service in the new, less flammable MIL-H-83282 hydrocarbon fluid to take advantage of the relaxed low temperature requirements.

For temperatures above +275°F, development work with fluorocarbon elastomers indicated long service life could be expected using MIL-H-83282 fluid but the low temperature capabilities would be limited to -10°F to -20°F for piston applications. Lower temperatures are possible on rod applications.

A further possibility was polyacrylate elastomers in MIL-H-83282 fluid. The reduced softening and lower swell in this fluid warranted compound investigation in this area.

The aim of the compound development work discussed in this report has been:

- (i) to optimize the dynamic properties of acrylonitrile compounds for MIL-H-5606B and MIL-H-83282 service while maintaining good compression set and heat aging characteristics
- (ii) to study the properties of fluorocarbon elastomers at temperatures above +275°F
- (iii) to develop suitable polyacrylate compounds for dynamic service in MIL-H-83282 fluid
- (iv) to study "second generation" polymers such as Phosphazine, a phosphonitrilic fluoroelastomer.

These goals will be discussed in this section of the report.

#### III-1 DEVELOPMENT OF ACRYLONITRILE COMPOUNDS:

As previously reported a study of the dynamic wear patterns of these improved heat resistant acrylonitrile compounds clearly showed some lack of abrasion resistance or resistance to flow.

This could be explained by a study of the filler systems used in these compounds. Carbon Black that gives optimum compression set resistance, which is a very desirable property in any seal application, may not give good resistance to "flow" and abrasion. Compounds based on these types of carbon blacks may have very high modulus and the desired hardness range but under extreme temperature and pressure conditions they cannot withstand the constant abrasive action of a rod or a cylinder wall.

It has been the aim of this study to determine a satisfactory balance between compression set resistance and dynamic properties.

At the time of writing Technical Report AFML-TR-73-90 two compounds, AFE-XN1925-25 and AFE-XN1925-33, (see Table I) were determined to be of considerable importance. Long term dynamic tests on both piston and rod test equipment had shown encouraging results at +275°F.

Using these two compounds as the controls, varying carbon blacks and blends of carbon blacks were evaluated to determine if a more satisfactory balance could be found. In Tables I, I-A and II, II-A some of the compounds are reported. In most cases high modulus has been developed but at the peroxide level used, the elongations are not acceptable.

In the next series of compounds, Tables III through VII, (Compounds AFE-XN1925-48 through AFE-XN1925-60) basically the same carbon black types and blends have been used, but the peroxide levels have been adjusted to obtain a more desirable original elongation. It must be remembered that when using peroxide vulcanization



systems to obtain the improved compression set and heat resistance that elongations will be shorter than those obtained with sulfur donor systems.

The polymer selected in this study in which the low temperature service requirement is  $-65^{\circ}\text{F}$ , was Chemigum N917. This polymer is considered to be an improvement, particularly in processing, over the present MIL-P-25732B polymer. Other compound ingredients used were maintained at constant levels.

The general fluid aging differences between MIL-H-5606B and MIL-H-83282 are, as previously reported, very noticeable. In MIL-H-5606B, the trend is a loss in hardness of approximately 10 pts (Shore A) and a volume swell of approximately 15%. In MIL-H-83282 the trend is an increase in hardness of approximately 5 pts (Shore A) and a low volume swell. It appears from these general trends that the service life of the new heat resistant acrylonitrile seals at  $275^{\circ}\text{F}$  would be increased by changing from MIL-H-5606B to MIL-H-83282. This has also been indicated by the appearance of test seals from the dynamic evaluations on both the rod and piston rigs. (See Section VI.)

In Table VII a comparison has been made between Chemigum N917 (AFE-XN1925-48) and Perbunan N1807 (AFE-XN1925-63). Both compounds processed very well but there is a significant difference in the balance of fluid swell and low temperature properties. Perbunan N1807 could be used in MIL-H-83282 but the high swell and softening would not be acceptable in MIL-H-5606B.

### III-2 NON-EXTRACTABLE ANTIOXIDANTS IN ACRYLONITRILE POLYMERS

Non-extractable antioxidants have always been considered to be very important in extending the service life of hydraulic and fuel seals. Present systems such as

reacted amines, azoles and quinoline types are extracted by the service media which limits their effectivity in protecting the polymer against oxidative attack.

Some recent studies by Good Year - Chemical Division on non-extractable antioxidants in acrylonitrile polymers have shown interesting results in cadmium oxide/silica/carbon black compounds based on a Chemigum N917 type polymer. Comparative studies at 300°F in ASTM #1 and #3 oils followed by air aging at 300°F showed significant improvement in retention of tensile strength and elongation. Air aging at 300°F for 168 hours also showed considerable improvement in hardness, tensile and elongation changes.

In Tables VIII and VIII-A a comparison is shown between Chemigum N917 (AFE-XN1925-48), the experimental RCG5036 polymer, which contains the non-extractable antioxidant to which the standard Aminox/Antioxidant ZMB was added (AFE-XN1925-61) and RCG5036 without addition of antioxidants (AFE-XN1925-62).

The initial evaluation indicated that the addition of antioxidant to RCG5036 had retarded the system. A lower level of peroxide would be required as elongation values are low and modulus higher than with Chemigum N917.

Comparing AFE-XN1925-48 and AFE-XN1925-62, the air aging retention of properties after 168 hours at 275°F showed considerable improvement. In MIL-H-5606B the properties were equivalent but in MIL-H-83282 the tensile and elongation retentions were improved. The low temperature properties of RCG5036 were also better than Chemigum N917.

While no definite conclusion could be drawn from this initial study, the improvement in air aging alone would warrant further investigation of this polymer.

To study the effect of oil extraction on the antioxidant this series of compounds was then subjected to a series of oil agings in MIL-H-5606B at 275°F. As shown in Tables IX, X, XI and XII, 2-214 O-ring samples were aged for 22, 44, 66, 88, 110, 136 and 168 hours in fluid. After each aging period a subsequent 22 hour air aging was given to the samples. Physical properties and volume changes were determined.

An interpretation of the data is presented in Figure I and II where the elongation and tensile strength had been plotted against the time of aging in MIL-H-5606B fluid for compounds AFE-XN1925-48 and AFE-XN1925-62. Although there is considerable variation in some of the data, it appears that the non-extractable antioxidant does improve the aging characteristics. The method used in this evaluation may not have clearly illustrated the advantages of this type of antioxidant as the subsequent air aging was limited to 22 hours. Longer air agings may have shown a greater differential between the two compounds. Further work is necessary in this area.

# PERCENTAGE ELONGATION

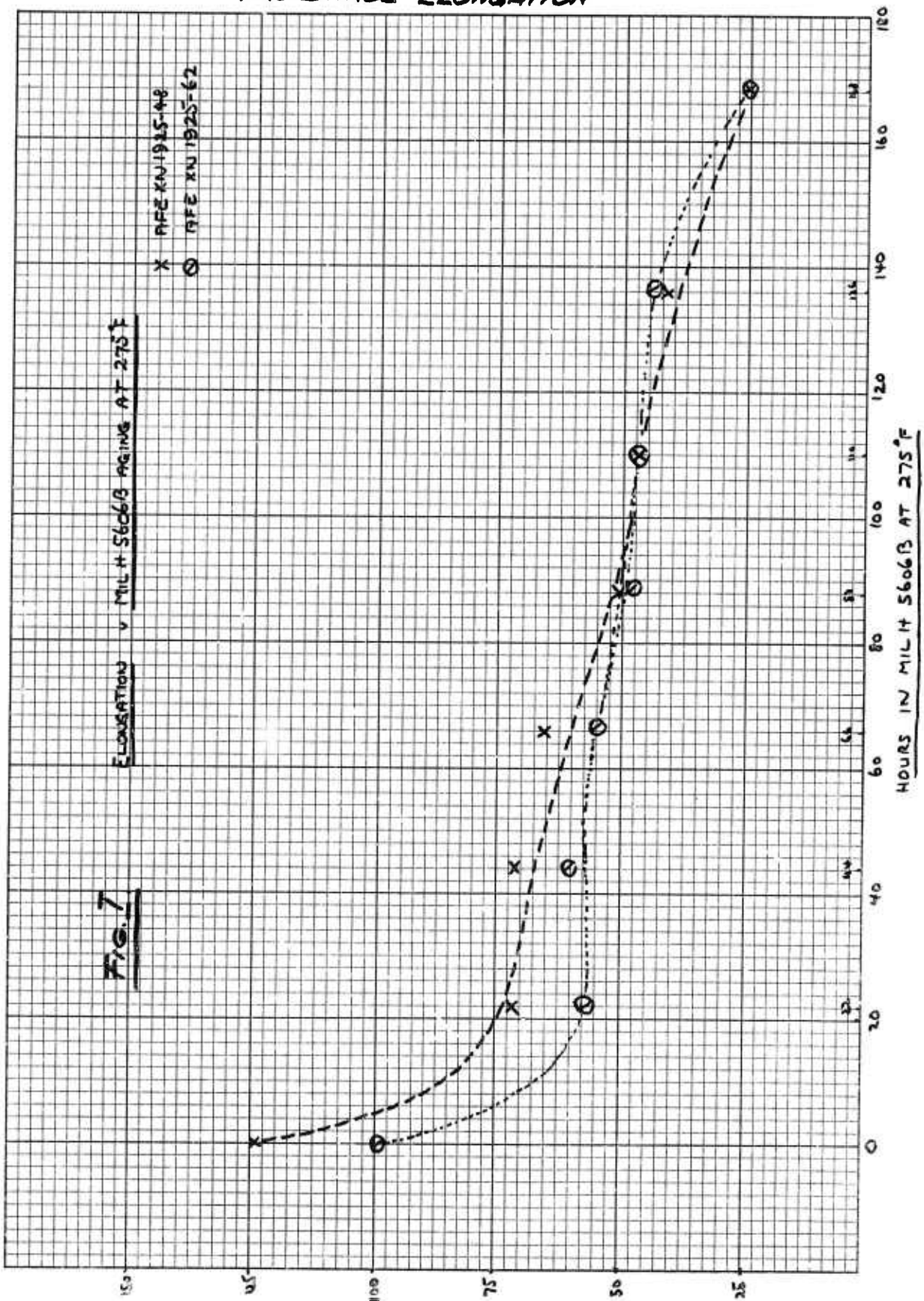

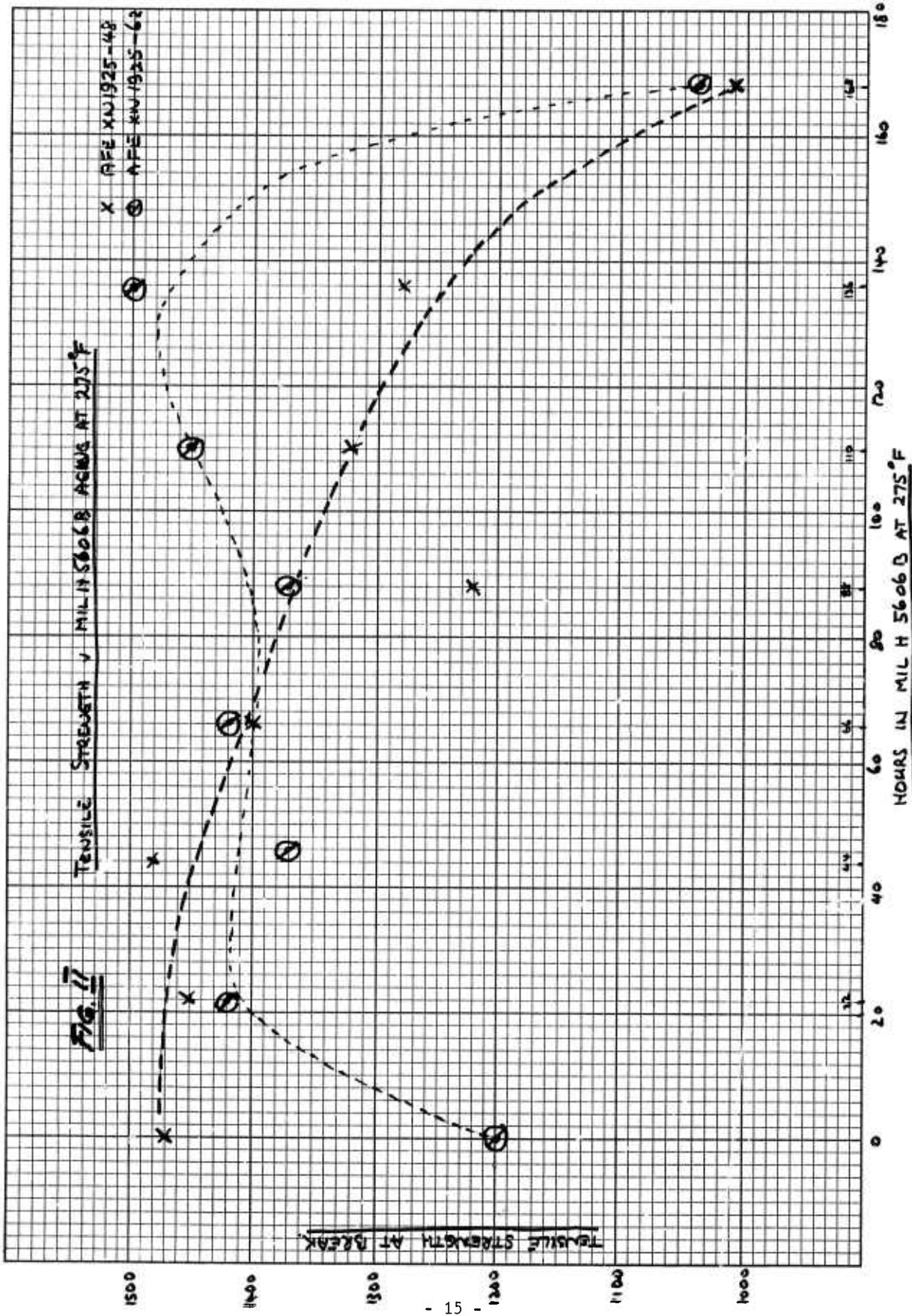

III-3

RECOMMENDED ACRYLONITRILE COMPOUNDS FOR FIELD EVALUATIONS

During the course of this contract Wright-Patterson Air Force Material Laboratory made a news release in which they recommended the field evaluation of two compounds developed in this program. (See Appendix I) The request for evaluation was sent to all aircraft hydraulics components manufacturers.

These two compounds were officially released as production materials and were given the following Parker identification numbers.

AFE-XN1925-33 - Parker Compound N756-75

AFE-XN1925-25 - Parker Compound N766-75

A Parker Seal O-Ring Technical Bulletin No. 40, "New Developments in Long Life Nitrile Seals for Hydraulic Systems," was released to give additional information to the component manufacture on the recommended use of these compounds. (See Appendix II) In this bulletin aging studies in air, MIL-H-5606B and MIL-H-83282 fluids and low temperature properties are presented. A comparison is shown between the present MIL-P-25732B compound N304-7, the two new compounds N756-75 and N766-75, and a commercial grade high temperature compound N741-75. Recommended service temperature ranges, and details of the dynamic test procedures used in the evaluation have been included.

III-4

FLUOROCARBON COMPOUNDS

Fluorocarbon elastomers are a very important class of materials in high temperature hydraulic systems. While the low temperature properties limit their use in some applications, it is the only polymer which can be used in systems at 350°F or above.

Table XIII shows the typical properties of present fluorocarbons. AFE-XV1836-7 and AFE-XV1836-9 are based on du Pont experimental polymers VT-X-3500 and VT-X-3553. AFE-XV1836-10 is based on du Pont's Viton E60C, while AFE-XV1836-11 is based on 3M's Fluorel 2170. Data presented includes original physical properties on slabs and 2-214 O-rings, aging and compression set in air at 392°F, aging and compression set in MIL-H-83282 at 392°F and low temperature properties. The conclusions from this study were:

- (i) The original physical properties of the various elastomers are very similar.
- (ii) There is no significant difference in air aging properties with the exception of compression set where the low temperature polymer (VT-X-3500) is notably poorer, i.e. 35% vs. 15%.
- (iii) In MIL-H-83282 fluid the changes in physical properties are again similar. The compression set resistance of VT-X-3500 in fluid is more comparable to the other polymers than was the case when aged in air.
- (iv) Comparing Viton E60C and Fluorel 2170, no significant difference can be found. Viton E60C does have slightly higher hardness, tensile and modulus but for all practical purposes these two elastomers are equivalent.
- (v) In processing studies Fluorel 2170 has been noted to have better flow and molding properties than Viton E60C. VT-X-3553 has similar processing characteristics to Fluorel 2170.

- (vi) VT-X-3500 has a 14F degree improvement over the Viton E60C and Fluorel 2170 type polymers when comparing the Temperature-Retracton TR-10 values.

III-5      COMPRESSION SET RESISTANCE OF FLUOROCARBON COMPOUNDS AT ELEVATED TEMPERATURES

With the increasing temperature requirements of hydraulic system into the 325°F to 450°F range and pressures exceeding 3000 psig it became apparent that addition data was required on the compression set resistance at these temperatures. A study was begun using Parker low compression set fluorocarbon compound, V747-75. In this study compression set was measured in air and MIL-H-83282 at 347°F, 392°F and 450°F for varying periods up to 168 hours. (See Table XIV) This study is presently being extended to 1000 hours at temperature.



# COMPRESSION SET - PERCENTAGE ORIGINAL DEFLECTION

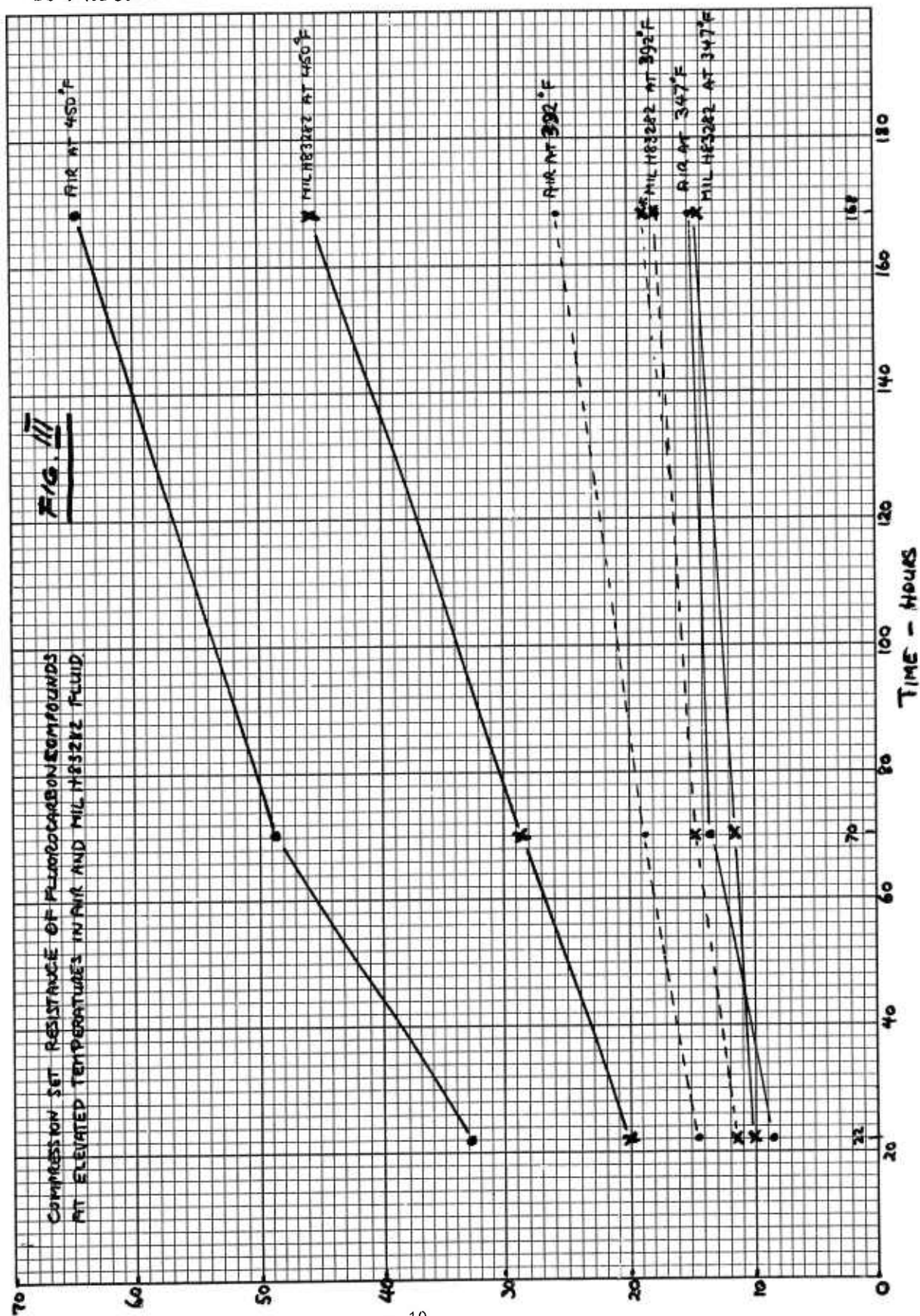

The results are presented in Figure III where it can be seen that at 347°F there is only minimum increase in set for 22 hours to 168 hours in both air and MIL-H-83282 fluid. The values in both media are very similar - around 14% after 168 hours.

With increasing temperatures the spread between air and MIL-H-83282 fluid values increases. After 168 hours at 392°F the values are 25.7% (air) and 18.6% (oil). After 168 hours at 450°F they are 64.3% (air) and 45.6% (oil). These values indicate that at 450°F the compression set will be a problem and failure will be experienced in less than 1000 hours of dynamic service. At 392°F the short term values look encouraging but further data will be required to establish the service life. These tests are presently in progress.

#### III-6        POLYACRYLATE COMPOUNDS

In earlier studies polyacrylate compounds have shown interesting properties in MIL-H-83282 fluid service. MIL-H-5606B fluid softens polyacrylates and causes relatively high swell, but in MIL-H-83282 fluid they have low swell and in some cases harden after aging at temperatures of 275°F and above.

Recently developed low temperature polyacrylates have made it possible to formulate compounds which have a temperature range of -40°F to 300°F or 325°F. In achieving this it has been generally found that the dynamic properties are impaired. It would, however, be of considerable interest for hydraulic systems using the MIL-H-83282 type fluid.

In Tables XV and XV-A low temperature polyacrylate compounds AFE-XA2016-1, AFE-XA2016-2 and AFE-XA2016-3 are compared to the Parker A607-7, an automotive grade polyacrylate.

Comparing data in the two fluids, the significant differences in swell and hardness change are clearly illustrated. AFE-XA2016-1 softens 21 pts (Shore A) and swells 25% in MIL-H-5606B after 70 hours at 275°F while in MIL-H-83282 the hardness change was 5 pts (Shore A) and 7% swell. It is also noted that with the improvement in low temperature properties the original tensile strength is reduced. This is generally considered a problem with processing and dynamic applications.

A second series of experimental compounds was studied in Tables XVI and XVI-A. These compounds, AFE-XA1969-47, AFE-XA1969-48 and AFE-XA1969-56, again showed promising properties at both 275°F and 302°F in MIL-H-83282. There has been no deterioration in properties with a 27°F degree increase in temperature.

Further agings were run on AFE-XA1696-56 at 350°F in MIL-H-83282 fluid. It is interesting to note the retention of physical properties at this temperature. The hardness increased by 3 pts (Shore A) and a volume change of +5.6%. The limitation appears to be compression set. With a TR-10 of -20°F and excellent retention of properties in MIL-H-83282 fluid at temperatures exceeding 300°F, a dynamic evaluation was proposed using MIL-H-83282 at 325°F, 50-3000 psi on the rod test rig. (See Section IV-2)

### III-7      PHOSPHAZINE COMPOUNDS

The second generation polymer Phosphazine - a phosphonitrilic fluoroelastomer which has been produced in small quantities on an experimental basis was made available by Firestone for evaluation in this program. Since only limited polymer was available all samples prepared were O-rings.

Tables XVII and XVII-A shows data on compounds AFE-XZ2046-2, AFE-XZ2046-5 and AFE-XZ2046-6. Comparing these results with fluorosilicone compound data in Technical Report AFML-TR-72-66, both polymers have similar characteristics. Both have good oil resistance and low temperature properties but obtaining acceptable dynamic properties appears a major problem. Further studies are planned with these polymers.

SECTION IV. DYNAMIC EVALUATION OF HYDRAULIC SEAL MATERIALS

IV-1 CHEW TEST EVALUATIONS AND THE EVALUATION OF BACK-UP SYSTEMS

In Technical Reports AFML-TR-72-66 and AFML-TR-73-90 the use of the Chew Tester has been discussed in detail. As in the past it has been found to be a valuable tool in the evaluation of both seals and back-up system.

The evaluation of back-up materials which was reported in AFML-TR-73-90 has been extended in the latest studies. Appendix III - Development of Back-up Rings for High Pressure, High Temperature Seals (Report 03-257 Rev A) discussed the detailed program which has been established for evaluation of seals and back-up systems at temperatures up to 400°F and pressures up to 4000 psig. It gives equipment modifications, assembly, test procedures and analysis details.

It is recommended that this type of procedure be established for the evaluation of all sealing systems (both rod and piston) as a systematic analysis will frequently explain the premature failure of sealing materials.

The development of back-up systems for high pressure, high temperature hydraulics was discussed in previous reports. In the chew test studies several approaches were taken. The following discussion will summarize the development work for both rod and piston systems.

The comments which follow are valid for the O-ring, back-up ring assemblies used as dynamic seals in the mechanisms subjected to reciprocating motion. The phenomena described below are of similar nature in both the piston and rod seal applications and differ only in their intensity. Since they appear to be more

drastic in case of the piston seals these seals will be discussed.

An O-ring of 75-80 shore hardness subjected to a reciprocating motion at 3000 psi pressure differential and at the temperature of 275°F or higher, would not tolerate an extrusion gap neither between the moving surfaces nor between the back-up ring and the bottom of the groove. (See AFML-TR-73-90)

To prevent nibbling or erosion of the O-Ring, a back-up ring of semi-rigid material must be installed with a slight interference fit with the groove. The back-up ring material must have a proper balance of physical properties, sufficient rigidity and resistance to extrusion on one hand and enough resilience and yielding ability on the other hand to expand laterally under the O-ring pressure and to maintain a zero gap even after a certain amount of wear. It must also possess a low coefficient of friction and not be abrasive. Temperature-resistant plastics as polyimides compounded with TFE appeared to be the best choice.

Seal assemblies consisting of fluorocarbon O-rings and of the aforementioned back-up rings completed successfully a number of standard 1000 hour tests at 3000 psi and 275°F. (See AFML-TR-73-90 Appendix VI and IX) The back-up rings made of Tetralon 720 and Revonoc 18158 plastics operated without excessive extrusion against the gaps between the cylinder and piston as large as .006 per side. However, with the test pressure increased to 4000 psi and the maximum test temperature increased to 350°F, the extrusion of the plastic back-up ring into the gap between the cylinder bore and the piston became excessive and led to the failure of the back-up rings and of the O-rings.

To provide a minimum extrusion gap between the moving surfaces and to maintain its width as uniform as possible, another back-up ring, this one made of a high grade pearlitic cast-iron, was installed downstream of the plastic back-up ring.

By installing the cast-iron back-up ring floatingly on the piston, the gap between the moving surfaces could be maintained nearly uniform in spite of the piston assuming an off-center position within its assembly tolerances. This arrangement required a larger compensating gap between the cast-iron back-up I.D. and the bottom of the piston groove. The price paid for such compensation was, however, an uneven extrusion of the plastic back-up ring into the compensation gap and creation of a lateral force pushing the cast-iron ring in the direction opposite to the off-center position of the piston. (See Appendix XI)

A thin intermediate metal ring assembled between the plastic and the cast-iron back-up rings and centered with a tight clearance on the bottom of the groove, stopped the extrusion into the compensating gap and nearly eliminated the lateral force. (10)

With the diametral clearance between the cylinder and the floating cast-iron ring reduced to .001-.003, the above seal arrangement became operative at 4000 psi max. pressure differential and at 350°F maximum temperature. Two 1000 hour tests were successfully completed. (See Appendix XI)

The above summary covers the first stage of the development of the high pressure, high temperature seal back-up system.

All the tests were performed on the 1.00 I.D. rod seals and on the 1.240 O.D. piston seals. The results of these tests are valid for the seals of the above diameters and would be valid for the seals of smaller diameters. The validity

of these tests cannot be extended, however, to seals of larger diameters, because of the following:

1. The O-rings used as dynamic seals in the reciprocating motion applications are subject to rolling. Rolling of the dynamic O-ring depends on several factors as: The O-ring diameter and the diameter of its cross section, its squeeze in the groove, the width of the groove, the pressure across the seal, the direction of the motion at the time of pressure application, the physical properties of the O-ring material at the operational temperature, the type and conditions of the back-up rings, their physical properties, particularly their compressive strength, their coefficient of friction and their abrasiveness.

In the same system the O-rings may roll under some conditions and remain static under others. With the piston operating usually in some off-center position with respect to the cylinder bore, the tendency to roll is often stronger at one part of the O-ring circumference than at the other.

This may lead to the spiral failure of the O-ring. (2) It is obvious that the danger of spiraling and of the spiral failure increases with the O-ring diameter.

Rolling of the O-ring cannot be theoretically predicted and must be tested under conditions identical with the conditions of the final application of the seal.

2. The extrusion of an O-ring or of a back-up ring depends on the width of the gap, but is almost independent on the diameter of the seal. On the other hand, the width of the extrusion gap is highly dependent



on the cylinder-piston diameter, because of the manufacturing tolerances assembly and functional fit requirements, cylinder breathing, differential thermal expansion, etc. Consequently, maintenance of a .003 gap considered as marginal for operations at 3000 psi and 350°F would be almost impossible on cylinders of large diameters.

#### IV-1-a CHEW TEST EVALUATION OF T-SEALS

It has been proposed that seal configuration other than O-rings may be of interest in some hydraulic applications. Problems with spiral failures of O-rings, particularly with larger size rings, have resulted in the use of T-seals in some application such as accumulators.

For this reason a preliminary study of T-seals and back-up systems was made using the Chew Test Rig. The aim was to develop a back-up system for 350°F/ 50-4000 psig using MIL-H-83382 fluid. The study was more complex than for the case of an O-ring. The following series of photographs will illustrate some of the problems which were experienced with this design. Further work and analysis of the problem is required. See Evaluation of V720 T-seals on the Rod Test Rig - Section IV-2

The first test to be run was a standard V747-75 T-seal. (.139" c/s in a .188" gland with Revonoc 18158 back-up as shown in Figure IV.

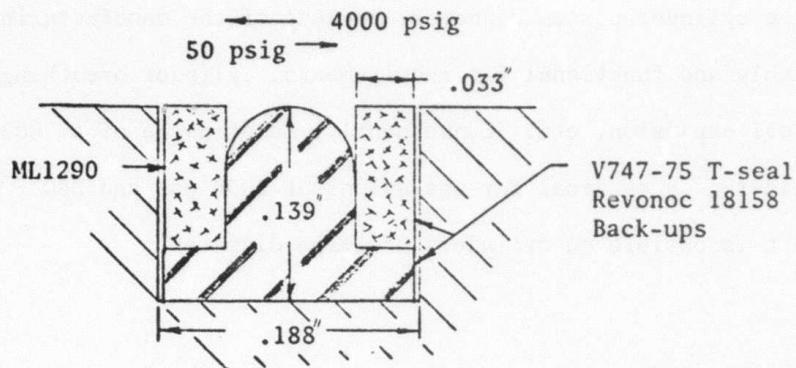

Figure IV.

V747-75 T-Seal with Standard Revonoc 18158 Back-ups.

As can be seen in Photograph No. 1 serious damage occurred after 30,600 cycles 350°F/4000 psig.



Photograph 1.

V747-75 T-Seal 30,600 cycles 350°F/4000 psig

An examination of the seals and back-ups showed excessive extrusion had occurred which resulted in total failure of the seal.

The second test run was under similar conditions using Parker Compound V720-75 which is also a low set fluorocarbon - as shown in Figure V.

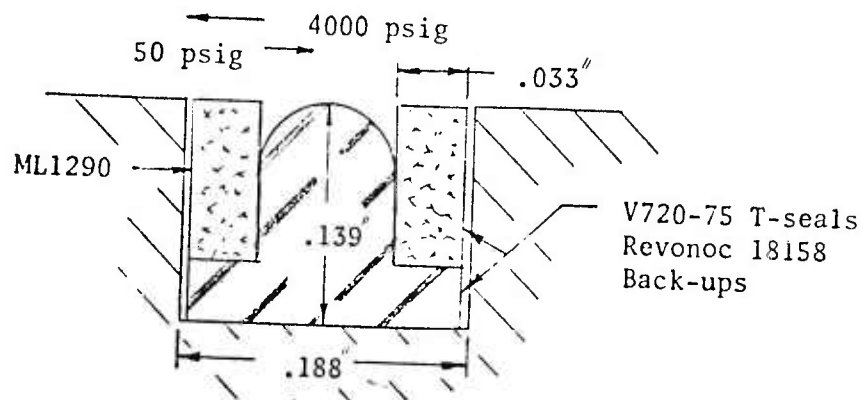
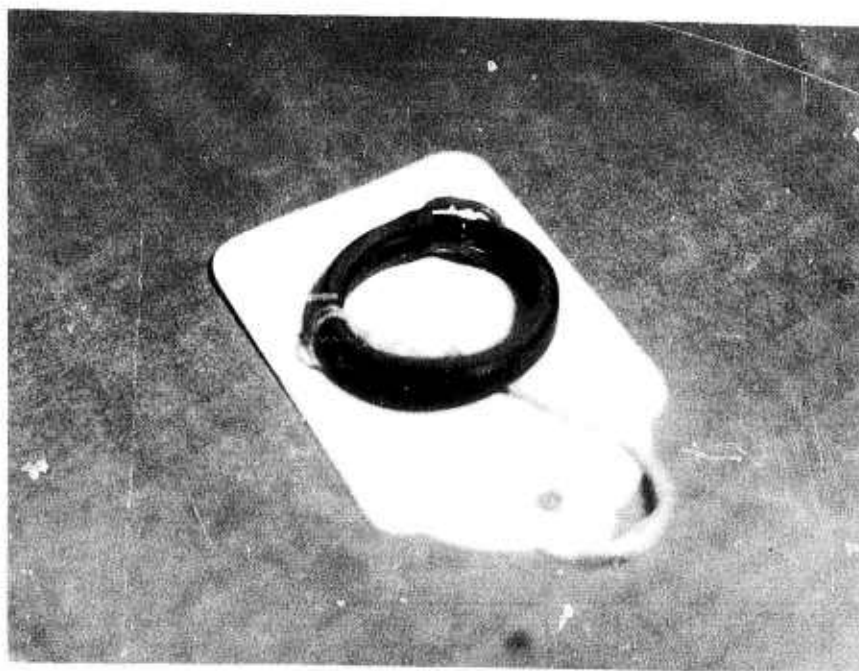

Figure V.



Photograph 2.

V720-75 T-Seal with Standard Revonoc 18158 Back-ups

The third test in this series was similar to the above except a split back-up ring was used for easier installation. Photograph No. 3 clearly shows that this combination will not withstand the high pressure and temperature with the extrusion gap which is present in this equipment.

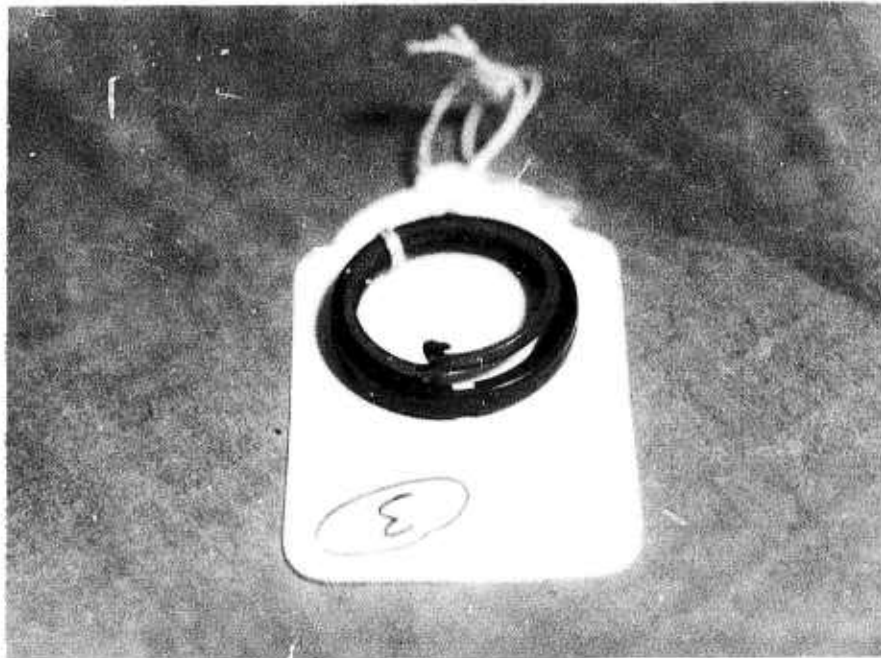

Photograph 3

V720-75 T-Seal with Standard Revonoc 18158 Back-ups

The next evaluations were using the larger groove (double back-up O-ring groove) T-seals of Parker Compound V720-75. The assembly is shown in Figure VI.

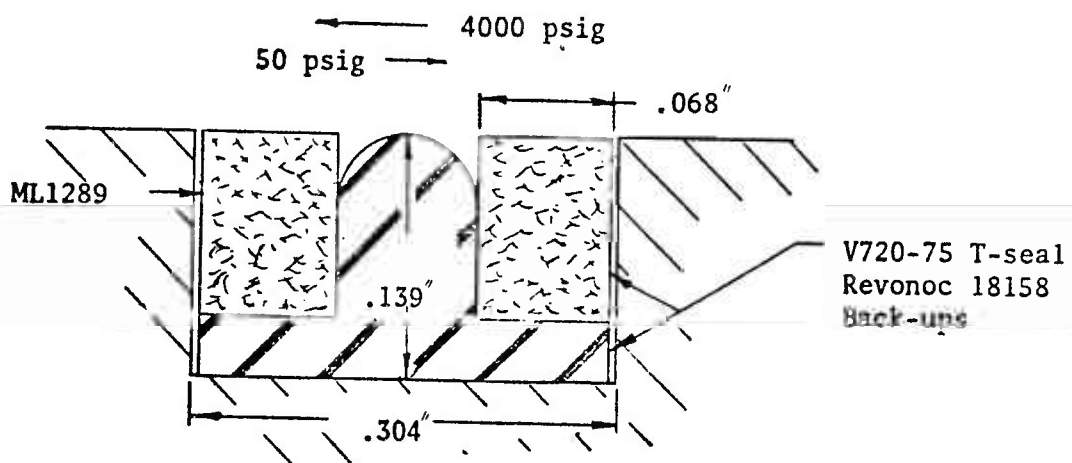
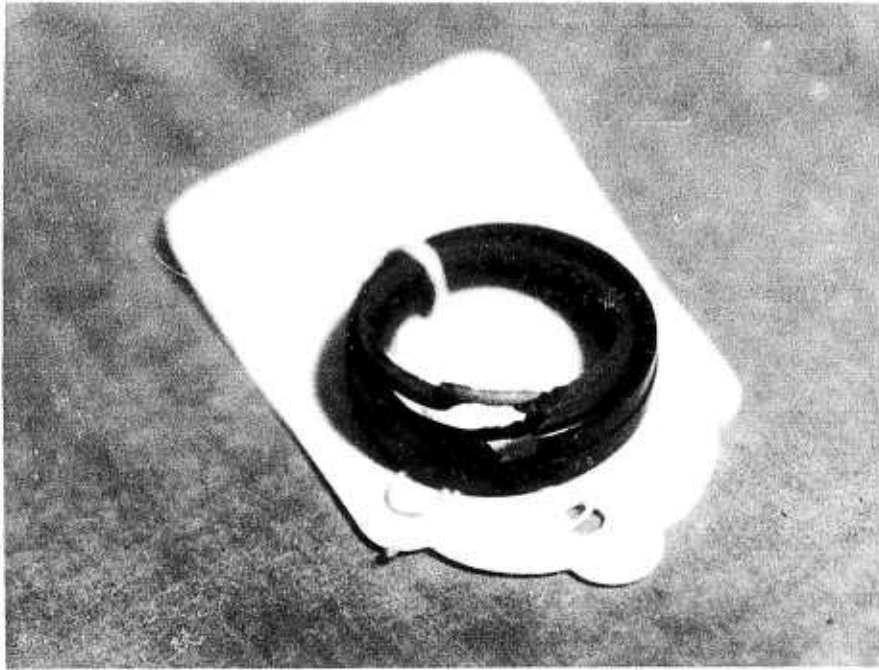

Figure VI.

V720-75/Revonoc 18158 in 0.304" Groove

Under similar conditions the heavier back-up ring was still not suitable and could not withstand the pressure. Early failure, as shown in Photograph No. 4, was found with tests run both at constant 4000 psig and also with 50-4000 psig tests.



Photograph 4.

V720-75/ Revonoc 18158 in 0.304" Groove

It was apparent from these tests a similar system to that used for the high temperature, high pressure O-rings system would have to be investigated for the T-seal.

With the materials and grooves which were available, it was decided to investigate the combination back-up system in the double back-up O-ring groove as shown below in Figure VII.

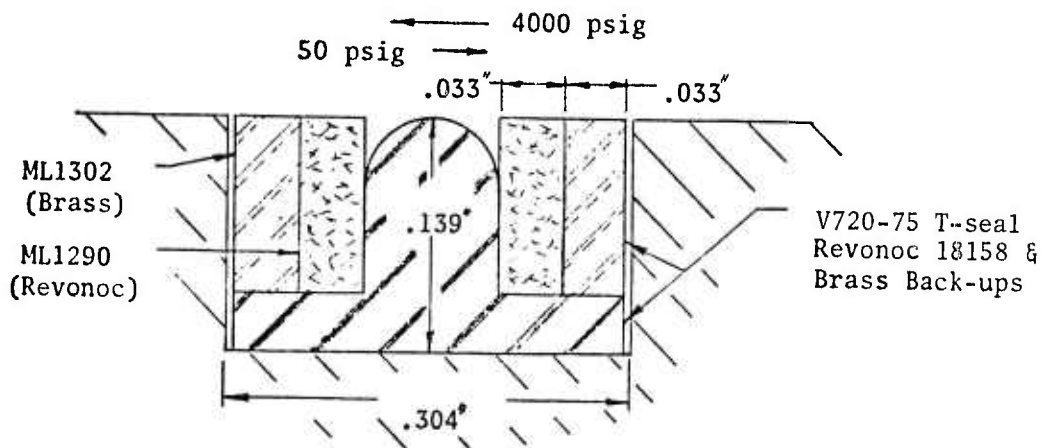

Figure VII.

V720-75 T-Seal in 0.304" Groove using Combined Brass/Revonoc 18158 Back-up System

The results of this short term test were more encouraging as shown in Photograph 5. The combination of the extrusion resistant brass and the sacrificial Revonoc 18158 withstood the 4000 psig/350°F conditions, but an examination of the seal indicated some nibbling and cutting of the seal where it was in contact with the brass back-up ring.



Photograph 5.

V720-75 T-Seal in 0.304" Groove Using Combined Brass/Revonoc 18158 Back-up System

Along similar lines the combination of cast-iron and Revonoc 18158 was investigated in the following configuration. (Figure VIII.

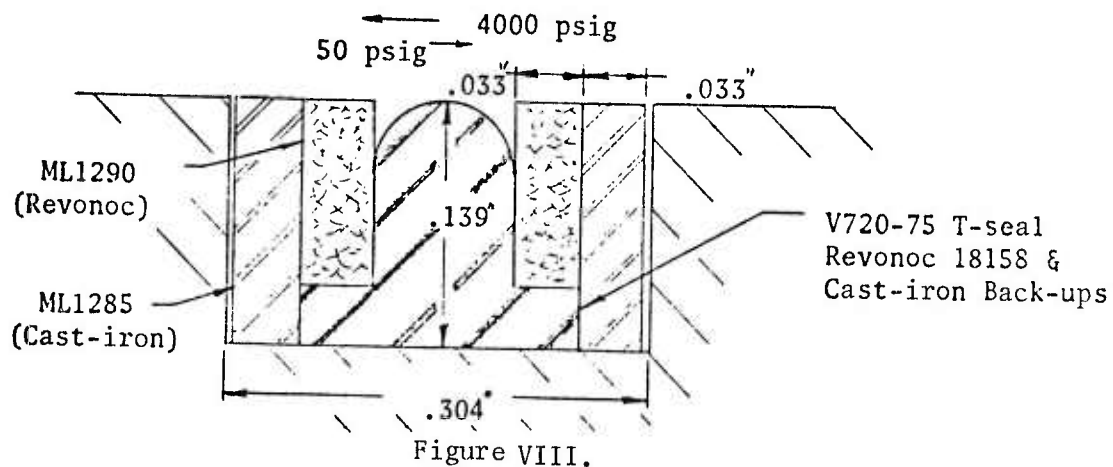

V720-75 Single T-Seal in 0.304" Groove Using Cast-Iron Spacer Back-up and Revonoc 18158 Back-up.

While this combination was found to give excellent protection to the seal in the sealing area, but Photograph 6 shows the damaged which occurred to the heel of the T-seal. Excessive cutting occurred in the area of contact of the T-seal heel and the cast-iron outer diameter.



Photograph 6.

V720-75 Single T-Seal in 0.304" Groove Using Cast-Iron Spacer Back-up and Revonoc 18158 Back-up

It was apparent from this study that the upstream cast-iron back-up could be replaced by a Revonoc 18158 back-up which could be placed between the cast-iron downstream back-up and heel of the T-seal as shown in Figure IX.

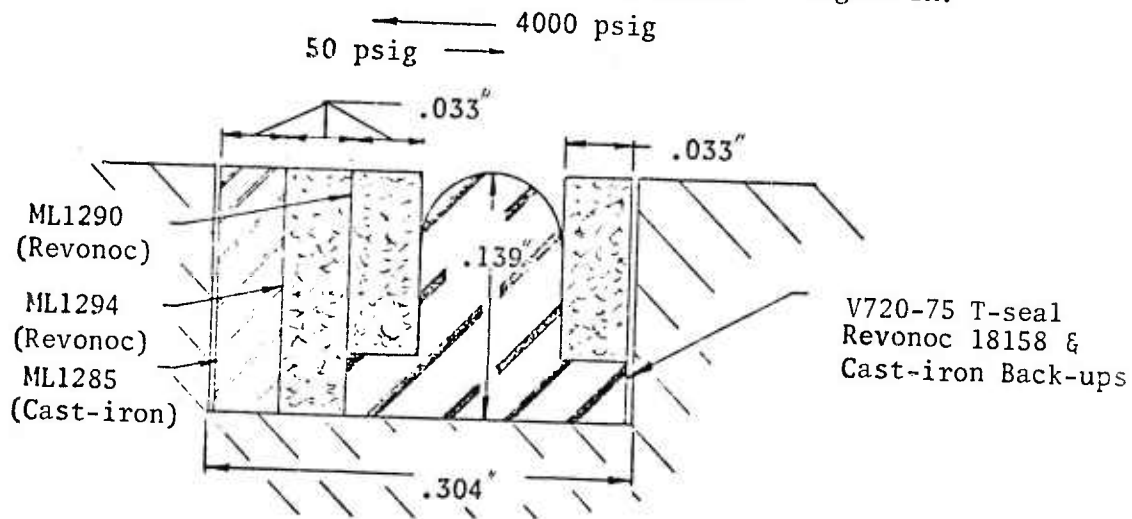

Figure IX.

V720-Single T-seal in 0.304" Groove Using Cast-Iron/Revonoc Spacer Back-ups Plus Revonoc 18158 T-Seal Back-ups.

This system was found to give excellent protection to the T-seal and it was proposed for long term evaluation of the Rod Test Rig. See Section IV-2-e and Appendixes XI and XII.

IV-2 EVALUATION OF SEAL MATERIALS ON THE ROD TEST RIG

IV-2-a EVALUATION OF AFE XN1925-25 AND AFE-XN1925-33 IN MIL-H-5606B 3000 PSIG 275°F

At the time of publishing Technical Report AFML-TR-73-90, compounds AFE-XN1925-25 and AFE-XN1925-33 were in the final stages of a 1000 hour test at 275°F in MIL-H-5606B fluid using Tetralon 720 back-up and a 50/3000 psi pressure system. This evaluation was successful for both compounds. In Appendix IV a detailed report (03-258) of the performance of both O-rings and back-up rings has been presented. This comprehensive report is a detailed analysis of the problem of selection of a suitable back-up system and seal material for long term service life.



A comparative study of the primary seals showed AFE-XN1925-33 had the better dynamic properties, remained flexible, had no erosion at the extrusion edge and had a high gloss in the areas where the O-ring touched the rod. On the other hand, AFE-XN1925-25 was brittle when flexed and erosion at the extrusion edge was due to local cracking and chipping of the O-ring material.

It is interesting to compare the formulation differences and physical properties of these two compounds (See Table I and I-A). While AFE-XN1925-25 has the superior compression set resistance, it appears that the change to the filler system used in AFE-XN1925-33 resulted in the superior dynamic service. This clearly illustrates the fact that laboratory aging tests of aging in air, oil and compression set resistance are not conclusive in studying the overall requirements of seal materials.

To illustrate the improvements achieved with AFE-XN1925-33 (Parker Compound N756-75) a cross sectional comparison was made with the seals used in the original rod test, in which the baseline was established with Parker Compound N304-7 (Technical Report AFML-TR-72-66, page 73), and the experimental compound.

Photograph 7 shows a section of an N304-7 2-214 O-ring after 754 hours at 275°F. At this point the test was terminated due to excessive leakage.

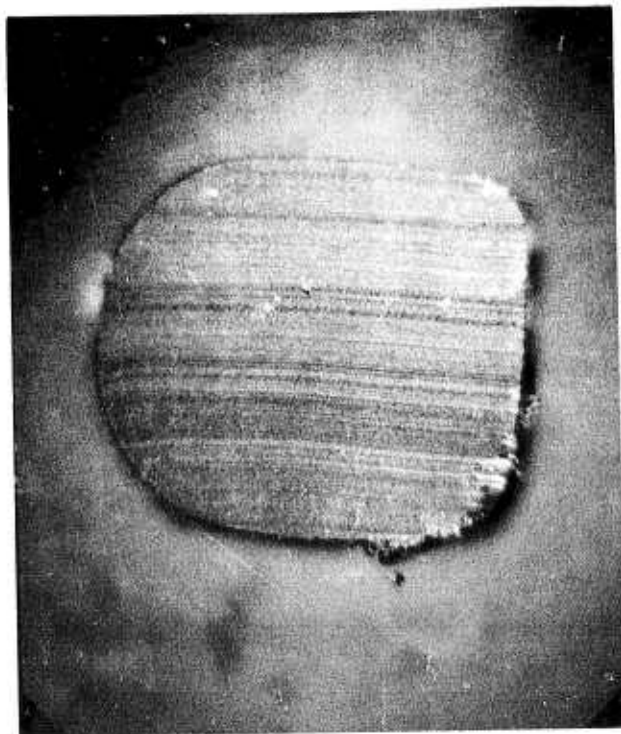

Photograph 7.

N304-7 Cross Section 2-214 O-ring after 754 Hours Service at 275°F on Rod Test Rig.



Photograph 8.

AFE-XN 1925-33 (N756-75) Cross Section 2-214 O-ring after 1000 Hours Service at 275°F on Rod Test Rig.

Photograph 8 shows a similar cross section of AFE-XN1925-33 after 1000 hours at 275°F. In this case no leakage was recorded. The actual service life of this material at 275°F has not been fully determined as all successful tests are terminated after 1000 hours at temperature.

It can be seen from these two photographs that a drastic improvement has been made in the compression set resistance of the seal. N304-7 after 275°F of the planned test period has taken a significant compression set and no longer supplies a sealing force against the rod. AFE-XN1925-33 on the other hand still retains much of its original cross sectional shape. This, plus its good abrasion resistance, has to date proven to be a Type II -65°F to +275°F nitrile compound.

#### IV-2-b EVALUATION OF AFE-XN1925-33 IN MIL-H-83282/4000 PSIG/275°F

The next dynamic evaluation was AFE-XN1925-33 in the new MIL-H-83282 fluid at 275°F using 50-4000 psig and Revonoc 18158 back-ups. While there were some problems with the dimensions of the back-ups, the dynamic seals were in excellent condition after the 1000 hour test. Some compression set was apparent but the seal surface in contact with the rod was flexible and in good conditions. AFE-XN-1925-33 has been demonstrated to be suitable for service in both MIL-H-5606B and MIL-H-83282 fluids at pressure up to 4000 psig and temperatures up to 275°F. Additional data is presented in Appendix V.

#### VI-2-c EVALUATION OF AFE-XV1836-10 IN MIL-H-83282/4000 PSIG/275°F

The final test to be evaluated at 275°F was AFE-XV1836-10, a fluorocarbon compound based on Viton E60C. The conditions of the test were MIL-H-83282 fluid, Revonoc 18158 back-ups, 50-4000 psig and temperature range from -65°F

to +275°F. As expected the fluorocarbon seals were in excellent condition when examined after the 1000 hour evaluation. The seals showed only minimal compression set and were in excellent condition. As reported in Appendix VI, one seal had some irregular wear marks which could be attributed to the back-up system.

AFE-XV1836-10, with a TR-10 value of +2°F, again illustrated the irregular low temperature sealing capabilities of the rod seal test. This compound did not leak at -65°F but in a later piston seal test it would only seal at -20°F which is in accordance with general technical recommendations for seal service.

Following this test the rod test rig was modified to handle higher temperatures. Additional heaters and insulation was added to allow temperatures up to 450°F to be maintained.

IV-2-d EVALUATION OF PARKER COMPOUND V747-75 AT 350°F, 4000 PSIG/  
USING CAST-IRON/REVONOC 18158 BACK-UPS

The next phase in the rod seal evaluation was to evaluate high temperature systems using fluorocarbon seals. From compression set and aging studies it appeared feasible for fluorocarbons, when installed with a suitable back-up system, to function at 350°F. It was apparent that the success of this evaluation would depend strongly on the dimensions of the combined cast-iron/modified Teflon back-up system. In Appendix VII a detailed outline of the analysis of the back-up is given. In systems of this type the importance of back-up system dimensions cannot be stressed strongly enough - they are critical!

Using MIL-H-83282 fluid and a cast-iron/Revonoc 18158 back-up system developed on the Chew Tester (See IV-1 and Appendix III) V747-75 successfully completed the 1000 hour test at 350°F.

The general appearance of the O-rings was very good. Compression set on all rings was slight and the slight marks, as discussed in Appendix VII, could be attributed to the movement and wear of the back-up system.

It has been established that with a suitable back-up system, fluorocarbon seals can be used at 350°F in MIL-H-83282 fluid and pressures up to 4000 psig.

IV-2-e EVALUATION OF PARKER COMPOUND V720-75 T-SEALS AT 350°F,  
USING CAST-IRON/REVNOC 18158 BACK-UPS

In conjunction with the above test, a further evaluation was run using a T-seal configuration. As discussed in Section IV-1-a this type of seal is used in applications where spiral failure is prevalent with O-rings. The conditions used were MIL-H-83282 fluid 50/4000 psig, a combination back-up system as shown in Figure X, Section IV-1-a and a temperature range of -65°F to +350°F. This test failed after 714 hours at 350°F. An analysis of the components showed excessive damage to both the back-ups and to the T-seals. Extrusion of the back-up on the upstream side confirmed an overfilled seal groove condition which could have resulted from thermal expansion of the materials. This is thought to be the cause of failure. Further analysis and design in this area is required.

IV-2-f EVALUATION OF PARKER COMPOUND V747-75 at 450°F, 4000 PSIG  
USING CAST-IRON/REVENOC 18158 BACK-UPS

Following the successful test at 350°F with the fluorocarbon compound the decision was made to push both the seal material and the fluid to their limits.

Initially it was considered that MIL-H-83282 was capable of 450°F. It was felt this temperature would also be the limit for the present fluorocarbon elastomers

In proposing this evaluation it was considered doubtful if a fluorocarbon seal would be capable of a 1000 hour test at 450°F but the data would give some idea of anticipated service life at this temperature. The conditions used were -40°F to +450°F, MIL-H-83282 fluid, 50-4000 psig, cast-iron/Revenoc 18158 back-ups. The test was terminated after 370 hours at 450°F, or 73,400 pressure cycles. No leakage was recorded at -40°F.

The analysis of the evaluation is given in Appendix VIII in which it was concluded that the failure resulted from excessive compression set. The seals had formed a D shape which increases the potential nibbling between the moving member and the back-up ring.

It is interesting to compare this evaluation with data presented in Section III-5 on the compression set of fluorocarbon compounds at elevated temperature. Values of 65% were obtained after 168 hours at 450°F. Additional data which is presently being prepared should give an interesting correlation with this dynamic evaluation.

The appearance of the test fluid indicated that degradation was occurring at 450°F. It appears that the upper limit of MIL-H-83282 fluid is lower than 450°F unless some form of inerting system is used to minimize the oxidative effect of the atmosphere. While this test did not complete the 1000 hour test, valuable data was collected on the service of this system at 450°F.

IV-2-g EVALUATION OF AFE-XA1969-56 AT 325°F, 4000 PSIG,  
USING CAST-IRON/REVENOC 18158 BACK-UPS

In view of the interesting results obtained with polyacrylates in MIL-H-83282 fluid (See Section III-6) the decision was made to evaluate AFE-XA1969-56 on the rod test rig. It was felt the improved properties obtained with AFE-XA1969-56 at temperatures of 302°F and 350°F, and the superior cast-iron/modified Teflon back-up system may be capable of 325°F dynamic service. The conditions used for this evaluation were 325°F/50-4000 psig, Revenoc 18158/cast-iron back-ups, MIL-H-83282 fluid. AFE-XA1969-56 successfully completed the 1000 hours at 325°F. Low temperature (-40°F) sealing was maintained throughout the evaluation. An examination of the dynamic seals revealed several interesting observations. While the back-up system functioned very well, there was some damage to the seals. The polyacrylate material remained flexible but it has taken a relatively high compression set and there was nibbling and erosion of some seals. This damage was not due to a malfunction of the back-up system.

While AFE-XA1969-56 successfully completed the test at 325°F, the appearance of the seal indicates further improvements in abrasion and nibbling resistance are required. This evaluation confirmed the feasibility of using polyacrylates in MIL-H-83282. Further developments in this area to determine if those problems can be overcome are desirable.

IV-3 EVALUATION OF SEAL MATERIALS ON THE PISTON TEST RIG

At time of publishing Technical Report AFML-TR-73-90 the only complete test to be run on the Piston Test Rig was experimental compound AFE-XN1814-98. Other tests were terminated due to mechanical failure or failure of the back-up systems.

While it had been established that a nitrile compound could complete the 1000 hour test no baseline had been established with the MIL-P-25732B specification material.

The first evaluation to be run was Parker Compound N304-7.

#### IV-3-a EVALUATION OF MIL-P-25732B COMPOUND N304-7

The aim of this evaluation is to establish a baseline with the MIL-P-25732B QPL compound N304-7. From this a comparison can be made with other experimental compounds.

It had been predicted that the high compression set of these QPL compounds plus extraction of the low temperature plasticizer would significantly reduce the -65°F service life when assembled in a piston system. This was found to be the case. N304-7 was assembled and run through a temperature range of -65°F to +275°F in MIL-H-5606B fluid, 50-3000 psig using a Tetralon 720 back-up system.

Low temperature leakage was initially noted after 200 hours at 275°F and it became progressively worse until at 500 hours pressure could not be held at -65°F or +275°F. At this point the evaluation was terminated. The examination of the seals and back-up system is discussed in detail in Appendix IX. As predicted, the high compression set of N304-7 was the major contributing factor to the seal failure.

With this data now available it can be concluded that an experimental compound which completes a 1000 hour test at 275°F is at least twice as effective as the present MIL-P-25732B QPL material.



IV-3-b THE LOW TEMPERATURE SEALING LIMITS OF FLUOROCARBON COMPOUNDS

As a result of the unpredicted low temperature sealing of fluorocarbon compounds on the rod test rig (See AFML-TR-72-66 and AFML-TR-73-90), a program was set up to evaluate the "true" low temperature sealing properties of fluorocarbon elastomers.

The test procedure used is discussed in Section VI-2 of AFML-TR-73-90. It was limited to an initial low temperature check at 3000 psig followed by eight hour cycling at 275°F with 50-3000 psig. A final low temperature is then made. The results of the evaluation are listed below:

<u>IDENTIFICATION</u>	<u>BASE POLYMER</u>	<u>INITIAL LOW TEMPERATURE CHECK</u>	<u>FINAL LOW TEMPERATURE CHECK</u>	<u>TR-10</u>
AFE-XV1836-10	du Pont E60C	Leakage at -5°F, -20°F and -40°F on LS, IS, and HS.	Leakage on LS at -20°F, sealed at -5°F Leakage on IS and HS at -40°F, sealed at -20°F on IS and HS.	+2°F
AFE-XV1836-11	3M 2170	Leakage at -5°F on LS. Leakage at -20°F on IS and HS.	Leakage at -20°F on LS, IS and HS. Sealed at -15°F.	+2°F
AFE JKS-VS-35	Not known	Leakage at -20°F on LS Leakage at -30°F on LS, IS, and HS.	Sealed at -30°F on LS, IS and HS. Leakage at -40°F on LS, IS and HS.	-15°F
AFE-XV1836-2	du Pont-Not known	Leakage at -40°F on LS, IS, sealed on HS.	Leakage at -20°F on LS. Leakage at -30°F on IS. Leakage at -40°F on IS and HS.	-26°F

LS = Low Squeeze (7.2%)                      IS = Intermediate Squeeze (11.5%)                      HS = High Squeeze (15.8%)

The conclusions drawn from this study were:

1. It has been clearly shown in these low temperature piston evaluations that the true low temperature sealing capability of a given fluorocarbon polymer or compound can be approximated by:
  - a. Determining the TR-10 value.
  - b. Reducing that value by approximately 15 to 20F degrees.  
  
i.e. A compound with a TR-10 of 0°F will seal at -15 to -20°F.  
A compound with a TR-10 of -10°F will seal at -25 to -30°F, etc.  
This has generally been found to be valid for other polymer classes.
2. The low temperature sealing capability may vary in accordance to the squeeze applied to the seals; i.e., the higher the squeeze, the better the change of improving the low temperature sealing but increases the compression set.
3. The dimensions of the back-up rings which were used in the first test of AFE-XV1836-2 resulted in the sealing on the intermediate squeeze and high squeeze pistons at -65°F. In this case the close tolerance interference fit of the back-ups assisted in sealing the viscous fluid at low temperature. In the second test where this was found not to be the case, the true sealing temperature was determined. A further property which was evaluated in this short term series of tests was the behavior of the back-up rings. The details of this portion of the study are presented in Appendix IX - Report 05-249 Addendum III.

IV-3-c EVALUATION OF AFE-XN1925-33 IN MIL-H-5606B/3000 PSIG/  
275°F USING REVENOC 18158 BACK-UPS

Following the successful evaluation of AFE-XN1925-33 on the rod test rig in which the superior dynamic wear characteristics were illustrated, this compound was then evaluated under similar conditions on the piston test rig.

AFE-XN1925-33 seals were installed with Revonoc 18158 back-ups, using MIL-H-5606B, 50-3000 psig and a temperature range of -65°F to +275°F. Toward the end of this 1000 hour test some minor leakage was recorded at -65°F on the low squeeze piston. Apart from this problem AFE-XN1925-33 successfully completed the test.

An examination of the dynamic seals showed they had taken a moderate set and were flexible. There was some small splits and very slight erosion on two seals. It appears the piston test was more severe than the pertinent rod test.

Details of the O-ring and back-up analysis are given in Appendix X.

It appears from the two dynamic evaluations of AFE-XN1925-33 that this compound is suitable for field evaluations in Type II -65°F to +275°F piston and rod type hydraulic systems.

IV-3-d EVALUATION OF PARKER COMPOUND V747-75 IN MIL-H-83282 FLUID,  
350°F, 4000 PSIG USING CAST-IRON/REVENOC 18158 BACK-UPS

This evaluation was the first on the piston test rig at temperatures above 275°F. It is the counterpart to the rod test described in Section IV-2-d in which

V747-75 completed a 1000 hour test over a temperature range of -65°F to +350°F. This evaluation is among the most valuable to be run during this contract. The ability to protect the fluorocarbon dynamic seals has been tested to its limit. The results and analysis are considered to be very valuable in development of high temperature, high pressure systems. The importance of back-up design is clearly illustrated.

Of the three cylinders, both the intermediate and high squeeze pistons completed the 1000 hour evaluation at 350°F. The low squeeze test failed after 600 hours. Initially it was thought that the failure would have resulted from compression set combined with the low squeeze on the seal. A detailed analysis (see Appendix XI) determined the failure was due to the back-up system and not the primary seal. The back-up failure had caused damage to occur to the V747-75 O-ring. Modifications to the system were recommended.

The general appearance of the other O-rings was very good. They had taken a slight set and in some cases there were signs of some wear but they were flexible and in a generally good condition.

It is to be noted that the low temperature sealing limit on the first phase of the test was -20°F. On subsequent low temperature checks this was reduced to -10°F which agrees closely with the TR-10 °F low temperature sealing theory discussed in Section IV-3-6.

IV-3-e EVALUATION OF PARKER COMPOUND V747-75 in MIL-H-83282 FLUID  
450°F, 4000 PSIG USING CAST-IRON/REVONOC 18158 BACK-UPS

As in the case of the rod seal test program, the next evaluation was to increase the fluorocarbon temperatures to 450°F. Although this test only completed approximately one-third of the desired 1000 hour test, valuable information was obtained on the function of both O-rings and the back-up system at 450°F.

Again, as discussed in Appendix XII, problems were experienced with the back-up system. The failure was of similar nature to that at 350°F with the exception of a faster rate of extrusion of the sacrificial back-up material. Furthermore, the V747-75 O-rings had taken a very pronounced compression set which was similar to the rod seal case. In Appendix XII details of this test and a review of the capability of back-up systems for 275°F, 350°F and 450°F hydraulic systems are discussed.

IV-3-f EVALUATION OF INTERMEDIATE RING TO REDUCE EXTRUSION  
ON HIGH TEMPERATURE, HIGH PRESSURE SYSTEMS.

As discussed in Appendix XI and XII, the failure of fluorocarbons has in some ways been attributed to the movement of the cast-iron ring and the resultant extrusion of the sacrificial material. The intermediate ring concept which was proposed in Appendix XI and reviewed in Appendix XII was tested at 350°F using similar conditions - 4000 psi, MIL-H-83282 fluid and V747-75 O-rings.

The back-up system was comprised of the following:

- a) one cast-iron floating back-up ring
- b) one intermediate ring.
- c) two Revonoc 18158 sacrificial back-up rings.

As discussed in Appendix XII, the intermediate ring performed better than was expected. This test was limited to 100 hours at temperature with 67,000 cycles at 350°F. It was concluded from this short term test that this back-up system would be suitable for 350°F service. It has been recommended that further investigations be made in this area.

IV-3-g EVALUATION OF PARKER COMPOUND V747-75 AT 400°F IN MIL-H-83282,  
4000 PSIG USING CAST IRON/REVONOC 18158 BACK-UPS

Since at 450°F the service life of the fluorocarbon compound appears to be limited by

- i) the compression set of the material
- ii) the limitations of the back-up system
- iii) the thermal instability of the test fluid,

it was decided to run a further evaluation at 400°F. In this study the original back-up system would be evaluated against the intermediate ring system.

On Cylinder No. 1, (the low squeeze) the intermediate ring system was used.

On Cylinders No. 2 and No. 3, the Cast-Iron/Revonoc 18158 system was used.

Under these conditions Cylinder No. 1 failed after 700 hours at 400°F. Cylinder No. 2 failed after 600 hours. An examination of the seals after the completion of the evaluation shows the following:

- i) At 400°F the compression set of V747-75 was again very high. It appears that 400°F may be too high a temperature for the 1000 hour test.
- ii) The back-up system performed very well. The intermediate

ring with double Revonoc 18158 back-up appeared beneficial to the seal performance.

- iii) The test fluid again showed signs of thermal instability and oxidation.

A detailed description of the assembly and a discussion of the results are given in Appendix XIV.

SECTION V.      LIST OF TABLES

ACRYLONITRILE COMPOUNDS

Table I

Formulation

<u>Compound No.</u>	<u>AFE-XN1925-25</u>	<u>AFE-XN1925-33</u>	<u>AFE-XN1925-43</u>	<u>AFE-XN1925-44</u>
Krynac 2750	95.0	-	-	-
SBR 1500	5.0	-	-	-
Chemigum N917	-	100.0	100.0	100.0
Magnesium Oxide	5.0	5.0	5.0	5.0
B8465 Cadmium Oxide	5.0	-	-	-
Zinc Oxide	-	5.0	5.0	5.0
N330 HAF	-	40.0	15.0	-
N440 FF	-	-	-	45.0
N550 FEF	30.0	35.0	65.0	45.0
N650 GPF-HS	-	-	-	-
N774 SRF	30.0	-	-	-
N990 MT	30.0	-	-	-
Aminox	1.0	1.5	1.5	1.5
Antioxidant ZMB	1.0	1.5	1.5	1.5
Dibutoxyethyl Sebacate	5.0	10.0	10.0	10.0
Diethylhexyl Azelate	5.0	10.0	10.0	10.0
Varox	3.0	3.5	3.5	3.5

Original Physical Properties: (6" x 6" x .075" slabs)

Hardness, Shore A, (pts)	75	77	78	77
Tensile Strength, (psi)	2130	2040	2130	1780
Elongation, (%)	140	126	112	112
Modulus at 100% Elong. (psi)	1300	1370	1820	1470
Specific Gravity	1.26	1.21	1.23	1.24

Original Physical Properties: (2-214 O-rings)

Hardness, Shore At, (pts)	72	73	78	78
Tensile Strength (psi)	1590	1380	1400	1310
Elongation, (%)	148	118	94	97
Modulus at 100% Elong. (psi)	851	1050	-	-



ACRYLONITRILE COMPOUNDS

Table I-A

Compound No.	<u>AFE-XN1925-25</u>	<u>AFE-XN1925-33</u>	<u>AFE-XN1925-43</u>	<u>AFE-XN1925-44</u>
<u>Aged in Air (oven) 168 hrs @ 275°F</u>				
Hardness, Change, %	94(+19)	95(+18)	95(+17)	96(+19)
Tensile, Change, %	1120(-47)	1650(-19)	1330(-38)	1400(-21)
Elongation, Change, %	24(-83)	38(-69)	20(-82)	19(-83)
Modulus at 100%, Change, %	-	-	-	-
<u>Compression Set 25% Deflection - 70 hours at 275°F</u>				
% Original Deflection (plies)	20.5	50.0	44.8	47.2
(2-214)	45.1	60.7	61.7	60.8
<u>Aged in MIL-H-5606B - 168 hours @ 275°F</u>				
Hardness, Change, pts.	67(-8)	67(-10)	69(-9)	68(-9)
Tensile, Change, %	1500(-30)	1310(-35)	1350(-37)	1360(-24)
Elongation, Change, %	81(-42)	92(-27)	73(-35)	76(-32)
Modulus at 100%, Change, %	-	-	-	-
Volume Change, %	+16.5	+14.7	+21.1	+19.3
<u>Aged in MIL-H-83282 - 168 hours @ 275°F (6" x 6" x .075" slabs)</u>				
Hardness, Change, pts	78(+3)	80(+3)	81(+3)	82(+5)
Tensile, Change, %	1030(-52)	1330(-34)	1590(-25)	1390(-22)
Elongation, Change, %	60(-57)	68(-46)	67(-40)	61(-45)
Modulus at 100%, Change, %	-	-	-	-
Volume Change, %	+5.2	+2.0	+1.0	+1.6
<u>Low Temperature Properties</u>				
Temperature Retraction TR-10 °F (2-218)	-39	-55	-53	-54

ACRYLONITRILE COMPOUNDS

Table II

Formulation

<u>Compound No.</u>	<u>AFE-XN1925-45</u>	<u>AFE-XN1925-46</u>	<u>AFE-XN1925-47</u>
Chemigum N917	100.0	100.0	100.0
Magnesium Oxide	5.0	5.0	5.0
Zinc Oxide	5.0	5.0	5.0
N330 HAF	-	-	-
N440 FF	-	-	-
N550 FEF	85.0	45.0	45.0
N650 GPF-HS	-	45.0	-
N774 SRF	-	-	35.0
Aminox	1.5	1.5	1.5
Antioxidant ZMB	1.5	1.5	1.5
Dibutoxyethyl Sebacate	10.0	10.0	10.0
Diethylhexyl Azelate	10.0	10.0	10.0
Varox	3.5	3.5	3.5

Original Physical Properties - (6" x 6" x .075" Slabs

Hardness Shore A, (pts)	81	82	75
Tensile Strength, (psi)	2340	2460	1930
Elongation, (%)	101	100	114
Modulus at 100% Elongation (psi)	2280	2460	1540
Specific Gravity	1.24	1.25	1.23

Original Physical Properties - (2-214 O-rings)

Hardness, Shore A, (pts)	81	81	76
Tensile Strength, (psi)	1520	1630	1410
Elongation (%)	87	87	101
Modulus at 100% Elongation (psi)	-	-	1390

ACRYLONITRILE COMPOUNDS

Table II-A

Compound No.	<u>AFE-XN1925-45</u>	<u>AFE-XN1925-46</u>	<u>AFE-XN1925-47</u>
--------------	----------------------	----------------------	----------------------

AGED PHYSICAL PROPERTIES

Aged in Air (oven) - 168 hrs @ 275°F

Hardness, Change, %	96(+15)	96(+14)	93(+18)
Tensile, Change, %	1450(-38)	1510(-39)	848(-56)
Elongation, Change, %	18(-82)	18(-82)	21(-82)
Modulus at 100%, Change, %	-	-	-

Compression Set 25% Deflection - 70 hours at 275°F

% Original Deflection (plies)	42.9	43.0	44.4
(2-214)	62.7	60.8	61.8

Aged in MIL-H-5606B - 168 hours at 275°F

Hardness, Change, pts.	73(-8)	72(-10)	66(-9)
Tensile, Change, %	1440(-39)	1100(-55)	1460(-24)
Elongation, Change, %	68(-33)	62(-38)	81(-29)
Modulus at 100%, Change, %	-	-	-
Volume Change, %	+19.3	+17.0	+19.8

Aged in MIL-H-83282 - 168 hours at 275°F (6" x 6" x .075" slabs)

Hardness, Change, pts.	84(+3)	84(+2)	80(+5)
Tensile, Change, %	1640(-30)	1200(-51)	1700(-12)
Elongation, Change, %	55(-46)	42(-58)	80(-30)
Modulus at 100%, Change, %	-	-	-
Volume Change, %	+1.7	+1.7	+1.7

Low Temperature Properties

Temperature Retraction TR-10 °F (2-218)	-54	-55	-54
--	-----	-----	-----

ACRYLONITRILE COMPOUNDS

Table III

Formulation

<u>Compound No.</u>	AFE-XN1925-48	AFE-XN1925-49	AFE-XN1925-50
Chemigum N917	100.0	100.0	100.0
Magnesium Oxide	5.0	5.0	5.0
Zinc Oxide	5.0	5.0	5.0
N550 FEF	35.0	35.0	35.0
N330 HAF	40.0	40.0	40.0
Aminox	1.5	1.5	1.5
Antioxidant ZMB	1.5	1.5	1.5
Dibutoxyethyl Sebacate	10.0	10.0	10.0
Diethylhexyl Azelate	10.0	10.0	10.0
Varox	3.25	3.0	3.25

Original Physical Properties - (6" x 6" x .075" Slabs)

Hardness Shore A, (pts)	75	73	72
Tensile Strength, (psi)	2090	2200	2090
Elongation, (%)	130	140	153
Modulus at 100% Elongation (psi)	1360	1220	997
Specific Gravity	1.22	1.21	1.21

Original Physical Properties - (2-214 O-rings)

Hardness, Shore A, (pts)	74	73	72
Tensile Strength, (psi)	1470	1660	1600
Elongation (%)	124	143	146
Modulus at 100% Elongation (psi)	953	864	808

ACRYLONITRILE COMPOUNDS

Table III-A

Compound No.	<u>AFE-XN1925-48</u>	<u>AFE-XN1925-49</u>	<u>AFE- XN1925-50</u>
--------------	----------------------	----------------------	-----------------------

AGED PHYSICAL PROPERTIES

Aged in Air (oven) - 168 hrs @ 275°F

Hardness, Change, %	95(+20)	87(+14)	94(+22)
Tensile, Change, %	1280(-39)	1470(-33)	1260(-40)
Elongation, Change, %	17(-87)	17(-88)	17(-89)
Modulus at 100%, Change, %	-	-	-

Compression Set 25% Deflection - 70 hours at 275°F

% Original Deflection (plies)	43.2	40.0	43.8
(2-214)	48.2	51.0	55.2

Aged in MIL-H-5606E - 168 hours at 275°F

Hardness, Change, pts.	66(-9)	65(-8)	62(-10)
Tensile, Change, %	1270(-39)	1390(-37)	1190(-43)
Elongation, Change, %	87(-33)	97(-31)	96(-37)
Modulus at 100%, Change, %	-	-	-
Volume Change, %	+17.8	+15.6	+15.8

Aged in MIL-H-83282 - 168 hours at 275°F (6" x 6" x .075" slabs)

Hardness, Change, pts.	80(+5)	79(+6)	74(+2)
Tensile, Change, %	1270(-39)	1490(-32)	1550(-26)
Elongation, Change, %	65(-50)	80(-43)	86(-44)
Modulus at 100%, Change, %	-	-	-
Volume Change, %	+0.8	+1.4	+1.4

Low Temperature Properties

Temperature Retraction TR-10 °F (2-218)	-55	-56	-56
--	-----	-----	-----

ACRYLONITRILE COMPOUNDS

Table IV

Formulation

<u>Compound No.</u>	<u>AFE-XN1925-51</u>	<u>AFE-XN1925-52</u>	<u>AFE-XN1925-53</u>
Chemigum N917	100.0	100.0	100.0
Magnesium Oxide	5.0	5.0	5.0
Zinc Oxide	5.0	5.0	5.0
N550 FEF	55.0	65.0	40.0
N440 FF	-	-	40.0
N330 HAF	15.0	-	-
Aminox	1.5	1.5	1.5
Antioxidant ZMB	1.5	1.5	1.5
Dibutoxyethyl Sebacate	10.0	10.0	10.0
Diethylhexyl Azelate	10.0	10.0	10.0
Varox	3.5	3.0	3.5

Original Physical Properties - (6" x 6" x .075" Slabs

Hardness Shore A, (pts)	72	71	75
Tensile Strength, (psi)	1990	1960	1940
Elongation, (%)	150	149	120
Modulus at 100% Elongation (psi)	884	1010	1410
Specific Gravity	1.21	1.20	1.22

Original Physical Properties - (2-214 O-rings)

Hardness, Shore A, (pts)	70	68	73
Tensile Strength, (psi)	1550	1510	1330
Elongation (%)	164	162	118
Modulus at 100% Elongation (psi)	693	677	989

ACRYLONITRILE COMPOUNDS

Table IV-A

Compound No.	<u>AFE-XN1925-51</u>	<u>AFE-XN1925-52</u>	<u>AFE-XN1925-53</u>
--------------	----------------------	----------------------	----------------------

AGED PHYSICAL PROPERTIES

Aged in Air (oven) - 168 hrs @ 275°F

Hardness, Change, %	92(+20)	92(+21)	95(+20)
Tensile, Change, %	1150(-42)	1170(-40)	1310(-32)
Elongation, Change, %	20(-87)	17(-89)	17(-86)
Modulus at 100%, Change, %	-	-	-

Compression Set 25% Deflection - 70 hours at 275°F

% Original Deflection (plies)	44.1	45.1	44.2
(2-214)	61.8	62.9	53.5

Aged in MIL-II-5606B - 168 hours at 275°F

Hardness, Change, pts.	62(-10)	58(-13)	66(-9)
Tensile, Change, %	1080(-46)	1040(-47)	1170(-40)
Elongation, Change, %	97(-35)	94(-37)	80(-33)
Modulus at 100%, Change, %	-	-	-
Volume Change, %	+15.5	+17.7	+13.6

Aged in MIL-H-83282 - 168 hours at 275°F (6" x 6" x .075" slabs)

Hardness, Change, pts.	78(+6)	73(+2)	82(+7)
Tensile, Change, %	1030(-48)	1420(-28)	1160(-40)
Elongation, Change, %	66(-56)	80(-46)	62(-48)
Modulus at 100%, Change, %	-	-	-
Volume Change, %	+1.7	+1.7	+1.0

Low Temperature Properties

Temperature Retraction TR-10 °F (2-218)	-55	-54	-59
--	-----	-----	-----

ACRYLONITRILE COMPOUNDS

Table V.

Formulation

<u>Compound No.</u>	<u>AFE-XN1925-54</u>	<u>AFE-XN1925-55</u>	<u>AFE-XN1925-56</u>
Chemigum N917	100.0	100.0	100.0
Magnesium Oxide	5.0	5.0	5.0
Zinc Oxide	5.0	5.0	5.0
N550 FEF	45.0	70.0	70.0
N440 FF	45.0	-	-
Aminox	1.5	1.5	1.5
Antioxidant 7MB	1.5	1.5	1.5
Dibutoxyethyl Sebacate	10.0	10.0	10.0
Diethylhexyl Azelate	10.0	10.0	10.0
Varox	3.0	3.5	3.0

Original Physical Properties - (6" x 6" x .075" Slabs

Hardness Shore A, (pts)	77	72	73
Tensile Strength, (psi)	1980	2130	2220
Elongation, (%)	129	155	149
Modulus at 100% Elongation (psi)	1290	976	1150
Specific Gravity	1.23	1.20	1.20

Original Physical Properties - (2-214 O-rings)

Hardness, Shore A, (pts)	73	72	72
Tensile Strength, (psi)	1420	1680	1630
Elongation (%)	131	140	142
Modulus at 100% Elongation (psi)	966	960	970



ACRYLONITRILE COMPOUNDS

Table V-A

Compound No.	<u>AFE-XN1925-54</u>	<u>AFE-XN1925-55</u>	<u>AFE-XN1925-56</u>
--------------	----------------------	----------------------	----------------------

AGED PHYSICAL PROPERTIES

Aged in Air (oven) - 168 hrs @ 275°F

Hardness, Change, %	95(+18)	93(+21)	93(+20)
Tensile, Change, %	1490(-25)	1110(-48)	1110(-50)
Elongation, Change, %	20(-84)	19(-88)	18(-88)
Modulus at 100%, Change, %	-	-	-

Compression Set 25% Deflection - 70 hours at 275°F

% Original Deflection (plies)	46.8	47.0	44.8
(2-214)	58.5	56.2	55.9

Aged in MIL-H-5606B - 168 hours at 275°F

Hardness, Change, pts.	65(-10)	62(-10)	65(-8)
Tensile, Change, %	1070(-46)	1280(-40)	1040(-53)
Elongation, Change, %	80(-38)	98(-37)	87(-42)
Modulus at 100%, Change, %	-	-	-
Volume Change, %	+15.2	+16.9	+21.9

Aged in MIL-H-83282 - 168 hours at 275°F (6" x 6" x .075" slabs)

Hardness, Change, pts.	83(+6)	77(+5)	77(+4)
Tensile, Change, %	1200(-39)	1260(-41)	1370(-38)
Elongation, Change, %	64(-50)	69(-55)	78(-48)
Modulus at 100%, Change, %	-	-	-
Volume Change, %	+1.4	+1.1	+1.1

Low Temperature Properties

Temperature Retraction TR-10 °F (2-218)	-57	-54	-56
--	-----	-----	-----

ACRYLONITRILE COMPOUNDS

Table VI

Formulation

<u>Compound No.</u>	<u>AFE-XN1925-57</u>	<u>AFE-XN1925-58</u>	<u>AFE-XN1925-59</u>
Chemigum N917	100.0	100.0	100.0
Magnesium Oxide	5.0	5.0	5.0
Zinc Oxide	5.0	5.0	5.0
N774 SRF	-	-	35.0
N650 GPF	40.0	40.0	-
N550 FEF	-	-	45.0
N440 FF	40.0	40.0	-
Aminox	1.5	1.5	1.5
Antioxidant ZMB	1.5	1.5	1.5
Dibutoxyethyl Sebacate	10.0	10.0	10.0
Diethylhexyl Azelate	10.0	10.0	10.0
Varox	3.0	2.5	3.0

Original Physical Properties - (6" x 6" x .075" Slabs

Hardness Shore A, (pts)	74	72	73
Tensile Strength, (psi)	1880	1955	2110
Elongation, (%)	148	172	158
Modulus at 100% Elongation (psi)	1000	780	1050
Specific Gravity	1.22	1.22	1.22

Original Physical Properties - (2-214 O-rings)

Hardness, Shore A, (pts)	67	68	71
Tensile Strength, (psi)	1450	1600	1620
Elongation (%)	176	187	155
Modulus at 100% Elongation (psi)	570	576	785

ACRYLONITRILE COMPOUNDS

Table VI-A

Compound No.	<u>AFE-XN1925-57</u>	<u>AFE-XN1925-58</u>	<u>AFE-XN1925-59</u>
--------------	----------------------	----------------------	----------------------

AGED PHYSICAL PROPERTIES

Aged in Air (oven) - 168 hrs @ 275°F

Hardness, Change, %	93(+19)	93(+21)	92(+19)
Tensile, Change, %	1280(-32)	1090(-44)	1040(-51)
Elongation, Change, %	20(-86)	20(-88)	21(-87)
Modulus at 100%, Change, %	-	-	-

Compression Set 25% Deflection - 70 hours at 275°F

% Original Deflection (plies)	49.6	49.1	38.8
(2-214)	68.6	65.7	61.9

Aged in MIL-H-5606B - 168 hours at 275°F

Hardness, Change, pts.	62(-12)	60(-12)	63(-10)
Tensile, Change, %	1110(-41)	952(-51)	1310(-38)
Elongation, Change, %	92(-38)	92(-47)	98(-38)
Modulus at 100%, Change, %	-	-	-
Volume Change, %	+19.1	+17.6	+15.3

Aged in MIL-H-83282 - 168 hours at 275°F (6" x 6" x .075" slabs)

Hardness, Change, pts.	76(+2)	75(+3)	78(+5)
Tensile, Change, %	1190(-37)	1070(-45)	1330(-37)
Elongation, Change, %	81(-45)	73(-58)	80(-49)
Modulus at 100%, Change, %	-	-	-
Volume Change, %	+1.1	+1.9	+1.4

Low Temperature Properties

Temperature Retraction TR-10 °F (2-218)	-57	-56	-56
--	-----	-----	-----

ACRYLONITRILE COMPOUNDS

Table VII

Formulation

<u>Compound No.</u>	<u>AFE-XN1925-60</u>	<u>AFE-XN1925-48</u>	<u>AFE-XN1925-63</u>
Chemigum N917	100.0	100.0	-
Perbunan N1807	-	-	100.0
Magnesium Oxide	5.0	5.0	5.0
Zinc Oxide	5.0	5.0	5.0
N774 SRF	35.0	-	-
N550 FEF	45.0	35.0	35.0
N330 HAF	-	40.0	40.0
Aminox	1.5	1.5	1.5
Antioxidant ZMB	1.5	1.5	1.5
Dibutoxyethyl Sebacate	10.0	10.0	10.0
Diethylhexyl Azelate	10.0	10.0	10.0
Varox	2.5	3.25	3.25

Original Physical Properties - (6" x 6" x .075" Slabs)

Hardness Shore A, (pts)	72	75	74
Tensile Strength, (psi)	2020	2090	2150
Elongation, (%)	168	129	131
Modulus at 100% Elongation (psi)	853	1360	1400
Specific Gravity	1.22	1.22	1.21

Original Physical Properties - (2-214 O-rings)

Hardness, Shore A, (pts)	68	74	75
Tensile Strength, (psi)	1630	1470	1600
Elongation (%)	193	124	123
Modulus at 100% Elongation (psi)	558	95.3	1160

ACRYLONITRILE COMPOUND

Table VII-A

Compound No.	<u>AFE-XN1925-60</u>	<u>AFE-XN1925- 48</u>	<u>AFE- XN1925-63</u>
--------------	----------------------	-----------------------	-----------------------

AGED PHYSICAL PROPERTIES

Aged in Air (oven) - 168 hrs @ 275°F

Hardness, Change, %	92(+20)	95(+20)	93(+20)
Tensile, Change, %	1130(-44)	1280(-39)	1420(-23)
Elongation, Change, %	30(-82)	17(-87)	34(-72)
Modulus at 100%, Change, %	-	-	-

Compression Set 25% Deflection - 70 hours at 275°F

% Original Deflection (plies)	44.4	43.3	51.1
(2-214)	68.6	48.2	60.8

Aged in MIL-H-5606B - 168 hours at 275°F

Hardness, Change, pts.	59(-13)	66(-9)	52(-21)
Tensile, Change, %	1190(-41)	1270(-39)	771(-58)
Elongation, Change, %	109(-35)	87(-33)	81(-33)
Modulus at 100%, Change, %	-	-	-
Volume Change, %	+16.6	+17.8	+32.5

Aged in MIL-H-83282 - 168 hours at 275°F (6" x 6" x .075" slabs)

Hardness, Change, pts.	74(+2)	80(+5)	77(+4)
Tensile, Change, %	1290(-36)	1270(-39)	1050(-43)
Elongation, Change, %	83(-51)	65(-50)	72(-40)
Modulus at 100%, Change, %	-	-	-
Volume Change, %	+1.8	+0.8	+5.2

Low Temperature Properties

Temperature Retraction TR-10 °F (2-218)	-56	-55	-65
--	-----	-----	-----

ACRYLONITRILE COMPOUNDS

Table VIII

Formulation

<u>Compound No.</u>	<u>AFE-XN1925-48</u>	<u>AFE-XN1925-61</u>	<u>AFE-XN1925-62</u>
Chemigum N917	100.0	-	-
Chemigum RCG5036	-	100.0	100.0
Magnesium Oxide	5.0	5.0	5.0
Zinc Oxide	5.0	5.0	5.0
N550 FEF	35.0	35.0	35.0
N330 HAF	40.0	40.0	40.0
Aminox	1.5	1.5	-
Antioxidant ZMB	1.5	1.5	-
Dibutoxyethyl Sebacate	10.0	10.0	10.0
Diethylhexyl Azelate	10.0	10.0	10.0
Varox	3.25	3.25	3.25

Original Physical Properties - (6" x 6" x .075" Slabs)

Hardness Shore A, (pts)	75	73	77
Tensile Strength, (psi)	2090	1690	1650
Elongation, (%)	129	128	100
Modulus at 100% Elongation (psi)	1360	1110	1650
Specific Gravity	1.22	1.21	1.21

Original Physical Properties - (2-214 O-rings)

Hardness, Shore A, (pts)	74	71	75
Tensile Strength, (psi)	1470	1230	1200
Elongation (%)	124	131	100
Modulus at 100% Elongation (psi)	953	773	1200

ACRYLONITRILE COMPOUNDS

Table VIII-A

Compound No.	<u>AFE-XN1925-48</u>	<u>AFE-XN1925- 61</u>	<u>AFE-XN1925-62</u>
--------------	----------------------	-----------------------	----------------------

AGED PHYSICAL PROPERTIES

Aged in Air (oven) - 168 hrs @ 275°F

Hardness, Change, %	95(+20)	92(+19)	93(+16)
Tensile, Change, %	1280(-39)	1470(-13)	1530(-7)
Elongation, Change, %	17(-87)	32(-75)	42(-58)
Modulus at 100%, Change, %	-	-	-

Compression Set 25% Deflection - 70 hours at 275°F

% Original Deflection (plies)	43.3	46.1	42.2
(2-214)	48.2	68.6	59.0

Aged in MIL-H-5606B - 168 hours at 275°F

Hardness, Change, pts.	66(-9)	63(-10)	69(-8)
Tensile, Change, %	1270(-39)	1040(-38)	985(-40)
Elongation, Change, %	87(-33)	89(-30)	66(-33)
Modulus at 100%, Change, %	-	-	-
Volume Change, %	+17.8	+15.9	+14.4

Aged in MIL-H-83282 - 168 hours at 275°F (6" x 6" x .075" slabs)

Hardness, Change, pts.	80(+5)	80(+7)	82(+5)
Tensile, Change, %	1270(-39)	1300(-23)	1270(-23)
Elongation, Change, %	65(-50)	71(-45)	65(-34)
Modulus at 100%, Change, %	-	-	-
Volume Change, %	+0.8	-0.7	-1.2

Low Temperature Properties

Temperature Retraction TR-10 °F (2-218)	-55	-59	-61
--	-----	-----	-----

Table IX

PHYSICAL PROPERTIES AND CHANGESCOMPOUND AFE-XN1925-48 2-214 O-RINGS

<u>FLUID AGING IN MIL-H-5606B @ 275°F FOLLOWED BY AIR AGING @ 275°F</u>	<u>Hardness Shore A,pts</u>	<u>Tensile (psi)</u>	<u>Elongation (%)</u>	<u>Modulus @ 50% psi</u>
Original Physical Properties	74	1470	124	360
22 hrs in MIL-H-5606B @ 275°F Followed by 22 hrs in air @ 275°F	88(+14)	1450(-1)	71(-43)	1010(+181)
44 hrs in MIL-H-5606B @ 275°F Followed by 22 hrs in air @ 275°F	89(+15)	1480(+1)	71(-43)	1020(+184)
66 hrs in MIL-H-5606B @ 275°F Followed by 22 hrs in air @ 275°F	90(+16)	1400(-5)	65(-48)	1040(+190)
88 hrs in MIL-H-5606B @ 275°F Followed by 22 hrs in air @ 275°F	90(+16)	1220(-17)	50(-60)	1210(+237)
110 hrs in MIL-H-5606B @ 275°F Followed by 22 hrs in air @ 275°F	91(+17)	1320(-10)	47(-62)	-
136 hrs in MIL-H-5606B @ 275°F Followed by 22 hrs in air @ 275°F	92(+18)	1280(-13)	42(-66)	-
168 hrs in MIL-H-5606B @ 275°F Followed by 22 hrs in air @ 275°F	95(+21)	1010(-31)	23(-81)	-



Table X

PHYSICAL PROPERTIES AND CHANGESCOMPOUND AFE-XN1925-61 2-214 O-RINGS

	<u>Hardness Shore A,pts</u>	<u>Tensile (psi)</u>	<u>Elongation (%)</u>	<u>Modulus @ 50% psi</u>
<u>FLUID AGING IN MIL-H-5606B @ 275°F FOLLOWED BY AIR AGING @ 275°F</u>				
Original Physical Properties	71	1230	131	325
22 hrs in MIL-H-5606B @ 275°F Followed by 22 hrs in air @ 275°F	91(+20)	1230(0)	63(-52)	1040(+220)
44 hrs in MIL-H-5606B @ 275°F Followed by 22 hrs in air @ 275°F	89(+18)	1460(+19)	72(-45)	1110(+242)
66 hrs in MIL-H-5606B @ 275°F Followed by 22 hrs in air @ 275°F	92(+21)	1500(+22)	72(-45)	1090(+235)
88 hrs in MIL-H-5606B @ 275°F Followed by 22 hrs in air @ 275°F	92(+21)	1400(+14)	61(-53)	1190(+266)
110 hrs in MIL-H-5606B @ 275°F Followed by 22 hrs in air @ 275°F	94(+23)	1490(+21)	58(-56)	1330(+309)
136 hrs in MIL-H-5606B @ 275°F Followed by 22 hrs in air @ 275°F	94(+23)	1320(+7)	39(-70)	-
168 hrs in MIL-H-5606B @ 275°F Followed by 22 hrs in air @ 275°F	94(+23)	1450(+18)	46(-65)	-

Table XI

PHYSICAL PROPERTIES AND CHANGESCOMPOUND AFE-XN1925-62 2-214 O-RINGS

	<u>Hardness Shore A, pts</u>	<u>Tensile (psi)</u>	<u>Elongation (%)</u>	<u>Modulus @ 50% psi</u>
<u>FLUID AGING IN MIL-H-5606B @ 275°F FOLLOWED BY AIR AGING @ 275°F</u>				
Original Physical Properties	75	1200	100	423
22 hrs in MIL-H-5606B @ 275°F Followed by 22 hrs in air @ 275°F	92(+17)	1420(+18)	56(-43)	1210(+186)
44 hrs in MIL-H-5606B @ 275°F Followed by 22 hrs in air @ 275°F	91(+16)	1370(+14)	59(-40)	1180(+179)
66 hrs in MIL-H-5606B @ 275°F Followed by 22 hrs in air @ 275°F	93(+18)	1420(+18)	54(-45)	1310(+210)
88 hrs in MIL-H-5606B @ 275°F Followed by 22 hrs in air @ 275°F	93(+18)	1370(+14)	47(-52)	-
110 hrs in MIL-H-5606B @ 275°F Followed by 22 hrs in air @ 275°F	94(+19)	1450(+21)	46(-53)	-
136 hrs in MIL-H-5606B @ 275°F Followed by 22 hrs in air @ 275°F	93(+18)	1500(+25)	43(-56)	-
168 hrs in MIL-H-5606B @ 275°F Followed by 22 hrs in air @ 275°F	95(+20)	1030(-14)	24(-76)	-

Table XII

FLUID AGING IN MIL-H-5606B @ 275°F  
 FOLLOWED BY AIR AGING @ 275°F

<u>VOLUME CHANGE</u> - Compound No. 2-214 O-rings	<u>AFE-XN1925-48</u>	<u>AFE-XN1925-61</u>	<u>AFE-XN1925-62</u>
22 hrs in MIL-H-5606B @ 275°F	+16.3	+17.8	+15.3
Followed by 22 hrs Air Aging @ 275°F	-12.7	-15.9	-15.7
44 hrs in MIL-H-5606B @ 275°F	+15.7	+17.4	+15.3
Followed by 22 hrs Air Aging @ 275°F	-12.7	-16.1	-15.8
66 hrs in MIL-H-5606B @ 275°F	+15.7	+18.0	+14.8
Followed by 22 hrs Air Aging @ 275°F	-12.6	-15.9	-15.6
88 hrs in MIL-H-5606B @ 275°F	+14.6	+17.6	+13.6
Followed by 22 hrs Air Aging @ 275°F	-13.0	-16.5	-15.9
110 hrs in MIL-H-5606B @ 275°F	+14.6	+16.9	+13.6
Followed by 22 hrs Air Aging @ 275°F	-13.1	-16.7	-16.1
136 hrs in MIL-H-5606B @ 275°F	+16.3	+17.6	+13.4
Followed by 22 hrs Air Aging @ 275°F	-12.6	-16.6	-16.1
168 hrs in MIL-H-5606B @ 275°F	+11.6	+15.8	+13.7
Followed by 22 hrs Air Aging @ 275°F	-13.8	-16.8	-16.5

FLUOROCARBON COMPOUNDS

Table XIII

Compound No.	<u>AFE-XV1836-7</u>	<u>AFE-XV1836-9</u>	<u>AFE-XV1836-10</u>	<u>AFE-XV1836-11</u>
Polymer	VT-X-3500	VT-X-3553	E60C	2170
<u>Original Physical Properties: 6" x 6" x .075" Slab</u>				
Hardness, Shore A, pts	74	79	79	76
Tensile, psi	2130	1850	2010	1750
Elongation, %	228	190	199	200
Modulus @ 100% elong. psi	850	868	932	779
Specific Gravity	1.85	1.84	1.84	1.85
<u>Original Physical Properties: 2-214 O-rings</u>				
Hardness, Shore A, pts	73	72	74	73
Tensile, psi	1950	1610	1780	1680
Elongation, %	220	178	187	207
Modulus @ 100% elong. psi	761	775	848	695
<u>Aged Physical Properties: 2-214 O-rings</u>				
<u>Aged in Air 70 Hours @ 392°F</u>				
Hardness, Change, pts	74(+1)	75(+3)	76(+2)	75(+2)
Tensile, Change, %	2200(+13)	1920(+19)	2280(+28)	1960(+17)
Elongation, Change, %	221(0)	183(+2)	200(+7)	206(0)
Modulus, Change, %	831(+9)	883(+15)	956(+13)	814(+17)
Compression Set 25% Deflection % Original Deflection	35.3	15.7	14.7	17.2
<u>Aged in MIL-H-83282 Fluid - 70 Hours @ 392°F</u>				
Hardness, Change, pts	71(-2)	73(+1)	74(0)	71(-2)
Tensile, Change, %	1580(-19)	1280(-20)	1650(-7)	1480(-12)
Elongation, Change, %	240(+9)	172(-3)	204(+9)	215(+4)
Modulus, Change, %	624(-18)	683(-12)	754(-11)	610(-12)
Volume Change, %	+1.5	+1.6	+1.5	+1.8
Compression Set 25% Deflection % Original Deflection	26.5	23.5	18.1	21.6
<u>Low Temperature Properties</u>				
<u>Temperature Retraction</u>				
TR-10 °F	-12	+1	+2	+2

Table XIV

COMPRESSION SET RESISTANCE OF FLUOROCARBON COMPOUNDS  
at  
ELEVATED TEMPERATURES IN AIR AND MIL-H-83282 FLUID

Compound No. Parker V747-75 - 2-214 O-rings

COMPRESSION SET 25% DEFLECTION - % ORIGINAL DEFLECTION (2-214 O-rings)

<u>In air at 347°F</u>	22 hrs	8.6
	70 hrs	13.3
	168 hrs	14.7
<u>In MIL-H-83282 at 347°F</u>	22 hrs	10.0
	70 hrs	11.4
	168 hrs	14.3
<u>In air at 392°F</u>	22 hrs	14.3
	70 hrs	18.6
	168 hrs	25.7
<u>In MIL-H-83282 at 392°F</u>	22 hrs	11.4
	70 hrs	14.3
	168 hrs	18.6
<u>In air at 450°F</u>	22 hrs	32.9
	70 hrs	48.6
	168 hrs	64.3
<u>In MIL-H-83282 at 450°F</u>	22 hrs	20.0
	70 hrs	28.6
	168 hrs	45.6

Table XV

POLYACRYLATE COMPOUNDS

<u>Formulations</u>	<u>AFE-XA2016-1</u>	<u>AFE-XA2016-2</u>	<u>AFE-XA2016-3</u>
Cyanacryl R8305-31/34	-	100.0	100.0
Hycar 4043	100.0	-	-
Sulfur	0.3	0.3	0.25
Stearic Acid	1.0	1.0	2.0
Aranox	0.75	0.75	-
Octamine	1.5	1.5	-
Aminox	-	-	2.0
HAF Black	80.0	80.0	-
FEF Black	-	-	60.0
TE 20	1.5	1.5	1.5
Postassium Stearate	1.5	1.5	-
Sodium Stearate	2.5	2.5	-
Curative C50	-	-	7.0
Curative C75	-	-	0.75

Table XV-A

POLYACRYLATE COMPOUNDS

Compound No.	<u>AFE-XA2016-1</u>	<u>AFE-XA2016-2</u>	<u>AFE-XA2016-3</u>	<u>Parker Compound A607-7</u>
<u>Original Physical Properties</u> -(6" x 6" x .075" Slabs)				
Hardness, Shore A, pts	84	81	66	66
Tensile, psi	1260	1140	1070	1970
Elongation, %	126	156	150	309
Modulus @ 100%, Elong, psi	1080	769	651	542
<u>Aged Physical Properties</u>				
<u>Aged in Air 70 hrs @ 275°F (% Change)</u>				
Hardness, Shore A	86(+2)	90(+9)	76(+10)	67(+1)
Tensile, psi	1170(-7)	1120(-2)	1240(+16)	1990(+1)
Elongation, %	113(-10)	98(-37)	116(-23)	281(-9)
Modulus @ 100%, psi	1090(+1)	-	1070(+64)	635(+17)
<u>ASTM #3 Oil 70 hrs @ 275°F (% Change)</u>				
Hardness, Shore A	66(-18)	59(-22)	56(-10)	53(-13)
Tensile, psi	1070(-15)	1130(-1)	1040(-3)	1890(-4)
Elongation, %	122(-3)	121(-22)	104(-31)	318(+3)
Modulus @ 100%, psi	876(-19)	905(+18)	960(+47)	533(-2)
Volume Change, %	+20.9	+15.9	+16.0	+12.7
<u>MIL-H-5606B Oil 70 hrs @ 275°F (% Change)</u>				
Hardness, Shore A	63(-21)	68(-13)	53(-13)	52(-14)
Tensile, psi	942(-25)	919(-19)	904(-16)	1740(-12)
Elongation, %	109(-13)	111(-29)	108(-28)	313(+1)
Modulus @ 100%, psi	881(-18)	823(+8)	844(+30)	460(-15)
Volume Change, %	+24.9	+19.4	+21.1	+14.7
<u>MIL-H-83282 Oil 70 hrs @ 275°F (% Change)</u>				
Hardness, Shore A	79(-5)	85(+4)	69(+3)	53(-13)
Tensile, psi	1170(-7)	1050(-8)	1150(+7)	1820(-8)
Elongation, %	124(-2)	88(-44)	111(-26)	308(0)
Modulus @ 100%, psi	976(-10)	-	1000(+54)	486(-10)
Volume Change, %	+7.4	+4.1	+4.5	+7.7
<u>Compression Set (Plied Sample) 70 hrs @ 275°F</u>				
Original Deflection	53.7	51.4	54.0	23.6
<u>Temperature Retraction</u>				
TR-10 °F	-35	-28	-35	+2

POLYACRYLATE COMPOUNDS

Table XVI

<u>Compound No.</u>	<u>AFE-XA1969-47</u>	<u>AFE-XA1969-48</u>	<u>AFE-XA1969-56</u>
<u>Formulation</u>			
Krynac XPRD-C-432	100.0	-	100.0
Krynac XPRD-C-434	-	100.0	-
Sulfur	0.25	0.25	0.25
Aminox	2.0	2.0	2.0
Stearic Acid	2.0	2.0	2.0
FEF N550	60.0	60.0	70.0
Sodium Stearate	1.75	1.75	1.75
Postassium Stearate	0.75	0.75	0.75
<u>Original Physical Properties (6" x 6" x .075" slabs)</u>			
Hardness, Shore A, pts	56	60	71
Tensile Strength, psi	1720	1740	1870
Elongation, %	282	244	142
Modulus @ 100% Elongation, psi	452	578	1210
Specific Gravity	1.27	1.29	1.30
<u>Aged Physical Properties (6" x 6" x .075" slabs)</u> <u>Aged in Air (oven) 70 hours @ 302°F</u>			
Hardness, Change, pts.	64(+8)	66(+6)	78(+7)
Tensile, Change, %	1940(+13)	1780(+2)	1800(-4)
Elongation, Change, %	252(-11)	224(-8)	130(-8)
Modulus @ 100%, Elongation %	569(+26)	649(+12)	1360(+12)
<u>Compression Set 25% Deflection 70 hours @ 302°F</u>			
% Original Deflection (plies)	40.6	45.2	49.9*
<u>Compression Set 25% Deflection 70 hours @ 350°F</u>			
% Original Deflection (2-214 O-rings)	-	-	88.1

\*2-214 O-rings



POLYACRYLATE COMPOUNDS

Table XVI-A

<u>Compound No.</u>	<u>AFE-XA1969-47</u>	<u>AFE-XA1969-48</u>	<u>AFE-XA1969-56</u>
<u>Aged in MIL-H-5606B 70 hrs @ 302°F (6" x 6" x .075")</u>			
Hardness, Change, pts	29(-27)	40(-20)	56(-15)
Tensile, Change, %	1080(-37)	1320(-24)	1480(-21)
Elongation, Change, %	203(-28)	200(-18)	144(+1)
Modulus @ 100% Elongation, Chg, %	330(-27)	461(-20)	830(-31)
Volume Change, %	+46.8	+27.8	+15.4
<u>Aged in MIL-H-83282 70 hrs @ 275°F (6" x 6" x .075")</u>			
Hardness, Change, pts	47(-9)	50(-10)	-
Tensile, Change, %	1650(-4)	1650(-5)	-
Elongation, Change, %	237(-16)	234(-4)	-
Modulus @ 100% Elongation, Chg, %	420(-7)	538(-7)	-
Volume Change, %	+9.0	+7.8	-
<u>Aged in MIL-H-83282 70 hrs @ 302°F (6" x 6" x .075")</u>			
Hardness, Change, pts	46(-10)	50(-10)	65(-6)
Tensile, Change, %	1760(+2)	1610(-7)	1650(-12)
Elongation, Change, %	251(-11)	202(-17)	132(-7)
Modulus @ 100%, Elongation, Chg %	451(0)	567(-2)	1100(-9)
Volume Change, %	+10.2	+6.3	+5.9
<u>Low Temperature Properties</u>			
<u>Temperature Retraction</u>			
TR-10 °F	-10	-19.5	-20
<u>Aged in MIL-H-83282 70 hrs @ 350°F (6" x 6" x .075")</u>			
Hardness, Change, pts	-	-	74(+3)
Tensile, Change, %	-	-	1070(-43)
Elongation, Change, %	-	-	90(-37)
Modulus @ 100% Elongation, Change, %	-	-	-
Volume Change, %	-	-	+5.6

PHOSPHAZINE COMPOUNDS

Table XVII

<u>Compound No.</u>	<u>AFE-XZ2046-2</u>	<u>AFE-XZ2046-5</u>	<u>AFE-XZ2046-6</u>
<u>(Original Physical Properties - (2-214 O-rings)</u>			
Hardness, Shore A, (pts)	52	71	65
Tensile Strength, (psi)	638	779	1150
Elongation, (%)	137	100	107
Modulus @ 100%, Elongation, (psi)	336	775	1040
Specific Gravity	1.81	1.83	1.81
<u>Aged Physical Properties (2-214 O-rings)</u>			
<u>Aged in Air (oven) 70 hrs @ 302°F</u>			
Hardness, Change, %	54(+2)	-	-
Tensile, Change, %	901(+41)	-	-
Elongation, Change, %	168(+23)	-	-
Modulus @ 100%, Change, %	361(+7)	-	-
Weight Change, %	-2.7	-	-
<u>Compression Set -25% Deflection</u>			
<u>% Original Deflection</u>			
70 hours @ 275°F	38.2	-	-
70 hours @ 302°F	54.4	64.7	36.8
<u>Aged in ASTM #3 Oil 70 hrs @ 302°F</u>			
Hardness, Change, %	51(-1)	-	-
Tensile, Change, %	722(+13)	-	-
Elongation, Change, %	173(+26)	-	-
Modulus @ 100%, Elong, Chg, %	237(-27)	-	-
Volume Change	+2.5	-	-
<u>Aged in MIL-H-5606B 70 hrs @ 302°F</u>			
Hardness, Change, %	-	60(-11)	57(-8)
Tensile, Change, %	-	883(+13)	684(-41)
Elongation, Change, %	-	137(+37)	130(+21)
Modulus @ 100%, Change, %	-	488(-37)	443(-57)
Volume Change, %	-	+6.2	+3.5
Weight Change, %	-	+2.4	+1.3
<u>Compression Set in MIL-H-5606B-25% Deflection</u>			
<u>% Original Deflection</u>	-	72.5	58.8

PHOSPHAZINE COMPOUNDS

Table XVII-A

	<u>AFE-XZ2046-2</u>	<u>AFE-XZ2046-5</u>	<u>AFE-XZ2046-6</u>
<u>AGED PHYSICAL PROPERTIES (2-214 O-rings)</u>			
<u>Aged in MIL-H-83282 70 hrs @ 302°F</u>			
Hardness, Change, %	-	62(-9)	56(-9)
Tensile, Change, %	-	851(+9)	726(-37)
Elongation, Change, %	-	136(+36)	130(+21)
Modulus @ 100%, Elongation, Chg, %	-	500(-35)	478(-54)
Volume Change, %	-	+1.8	+1.4
Weight Change, %	-	+0.6	+0.5
Compression Set in MIL-H-83282 - 25% Deflection % Original Deflection	-	67.6	33.9
<u>Low Temperature Properties</u>			
Temperature - Retraction TR-10 °F	-71	-	-

SECTION VI.      APPENDIXES

DEPARTMENT OF THE AIR FORCE  
AIR FORCE MATERIALS LABORATORY (AFSC)



WRIGHT-PATTERSON AIR FORCE BASE, OHIO 45433

APPENDIX I

REPLY TO  
ATTN OF: AFML/MXE/P. A. House/55077

SUBJECT: Improved Hydraulic Seals

TO:

1. The Air Force Materials Laboratory, Nonmetallic Materials Division, is about to complete a phase of a contract with Parker Seal Company on improved hydraulic seals. This particular phase was directed toward the development of improved elastomeric seals for MIL-H-5606 hydraulic fluid over a temperature range of -65° to 275°F.
2. Presently used seals for this temperature range are covered by Specification MIL-P-25732B and are buna N elastomers. The best materials developed under the contract are also buna N but are peroxide cured. Attached is a data sheet showing properties of 2 peroxide cured materials, AFE-XN1925-25 and -33 and a qualified MIL-P-25732B material. Note that the most improvement is shown in the aging in MIL-H-5606 fluid. Aging data in MIL-H-83282 is also included.
3. Dynamic performance tests (both rod seal and piston seal) have been completed on the AFE-XN1925-25 compound. These tests show that the -25 materials will cycle for 1000 hours at 275°F and 3000 psi with filled Teflon back-up rings without failure in both MIL-H-5606 and MIL-H-83282 fluids. Testing was stopped at 1000 hours even though the seals had not failed. The qualified MIL-P-25732 material failed after 754 hours in MIL-H-5606.
4. AFE-1925-33 has already completed 1000 hours testing on the rod seal tester at 275° in MIL-H-5606 with no failure. Piston seal performance tests are now underway with the AFE-XN1925-33 material and MIL-H-5606 fluid. These tests will be completed in approximately 6 weeks. It is expected that the -33 material will outperform the -25 material. At any rate, a decision will be made by AFML on which is the better material when the performance tests are completed.
5. It is our desire to get this new technology used and we would like to furnish O-rings to those individuals interested in conducting an evaluation. If you have some equipment which you feel can be

improved by the use of this new O-ring material and you can evaluate the material in your equipment, we will furnish you the required samples. Send your requirements for sizes and amounts of O-rings to:

AFML/MXE/Mr. House  
Wright-Patterson AFB, Ohio 45433.

6. It is the AFML position that back-up rings should be used with these materials and that the back-ups should be filled Teflon. The particular back-ups used in the performance tests were Tetralon 720 manufactured by Tetrafluor Division of Royal Industries.

*Philip A. House*

PHILIP A. HOUSE  
Materials Engineering Branch  
Systems Support Division

1 Atch  
Seal Material Test Data

<u>COMPOUND NO.</u>	<u>AFF-XN1925-25</u>	<u>AFF-XN1925-33</u>	<u>Qualified MIL-P-25732B</u>
<u>Physical Properties, Unaged (6"x6"x.075" Slab)</u>			
Hardness Shore A, pts.	75	72	71
Tensile Strength, psi	2130	1840	2104
Elongation, %	140	127	194
Modulus at 100%, psi	1300	1160	819
Specific Gravity	1.26	1.22	1.26
<u>Physical Properties, Unaged (-214 O-rings)</u>			
Hardness Shore A, pts.	72	72	
Tensile Strength, psi	1590	1470	
Elongation, %	148	136	
Modulus at 100%, psi	851	831	
<u>Aged in Air, 168 hrs. @ 275°F (6"x6"x.075" Slab)</u>			
Hardness Change, pts.	94(+19)	95(+23)	97(+26)
Tensile Change, %	1120(-47)	1490(-19)	2124(+1.0)
Elongation Change, %	24(-83)	19(-85)	18(-91)
180°Bend	Pass	—	Fail
<u>Aged in MIL-H-5606B 168 hrs. @ 275°F (6"x6"x.075" Slab)</u>			
Hardness Change, pts.	67(-8)	65(-7)	59(-12)
Tensile Change, %	1500(-30)	1070(-42)	764(-63)
Elongation Change, %	81(-42)	85(-33)	48(-75)
Volume Change, %	+16.5	+15.5	+6.6
<u>Aged in MIL-H-83282 168 hrs. @ 275°F (6"x6"x.075" Slab)</u>			
Hardness Change, pts.	(Slab) 78(+3)	(Slab) 80(+8)	(-218 O-rings) 91(+16)
Tensile Change, %	1030(-52)	1080(-41)	750(-55)
Elongation Change, %	60(-57)	62(-51)	18(-90)
Volume Change, %	+5.2	+1.3	-4.4
<u>Compression Set, 25% Deflection Method B, 70 hrs. @ 275°F</u>			
% Original Deflection			
Plies	20.5	49.6	47.5
2-214	45.1	57.8	
<u>Low Temperature Properties</u>			
<u>Temperature Retraction, -218 O-rings</u>			
TR-10°F	-39	-53	-61

# O-RING

# TECHNICAL

B  
U  
L  
L  
E  
T  
I  
N

## APPENDIX II

SUBJECT: New Developments in  
Long Life Nitrile Seals  
for Hydraulic Systems

NUMBER: 40

- APPLICATION  
 COMPOUND  
 PRODUCT

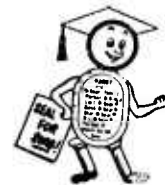

DIST.

P-3, D, R, T

DATE: September 14, 1973

During the past two years the R&D Group has been working on the problem of improving elastomeric seals for  $-65^{\circ}\text{F}$  to  $+275^{\circ}\text{F}$  service in MIL-H-5606B hydraulic fluid. This research work has been conducted under a Wright-Patterson Air Force Materials Laboratory contract.

This Technical Bulletin discusses some of the conclusions and recommendations resulting from this study.

In a recent release from Wright-Patterson AFB, two experimental compounds have been recommended for evaluation in hydraulic systems. They are

XN1925-33 which is now designated PARKER COMPOUND N756-75

and

XN1925-25 which is now designated PARKER COMPOUND N766-75.

This offers Parker Seal a unique opportunity to have our advancement in nitrile technology evaluated in service applications. While this development program was directed toward aircraft high temperature hydraulic service, it is worthwhile to note that it will also apply to the more stringent "under the hood" temperatures anticipated by the automotive industry. Off-the-road vehicles and oil field equipment could also benefit.

During the course of this development work two important conditions were introduced to the program. These are: 1) the more flame resistant hydraulic fluid MIL-H-83282 which was developed for  $-40^{\circ}\text{F}$  systems; and 2) seals were tested in conjunction with improved antiextrusion materials.

The following tables, recommendations and conclusions will show our solution to "The Dilemma of the  $275^{\circ}\text{F}$  Hydraulic System Seal."

### RECOMMENDED TEMPERATURE RANGES

As a result of these studies the following recommendations are made for nitrile compounds in MIL-H-5606B and MIL-H-83282 fluids.

kevin miller

- 81 -

Parker - SEAL GROUP

#### Parker N304-7

QPL compound for MIL-P-25732 actually is qualified for -65°F to +275°F service but is recommended for -55°F to +235°F. Where higher temperatures are encountered with N304-7, high compression set and aging may result in low temperature leakage. In MIL-H-83282 shrinkage may also result in low temperature leakage.

#### Parker N756-75

This is the best overall compound available and is recommended for -65°F to +275°F service. It has been developed for dynamic service in MIL-H-5606B fluid (-65°F) and is also suitable for MIL-H-83282 over a similar temperature range.

#### Parker N766-75

N766-75 was designed primarily for static and dynamic service in MIL-H-83282 fluid and is suitable for -40°F to +275°F. It is also acceptable for MIL-H-5606B fluid service. It is recommended for both fluids at +275°F but may be marginal at -65°F.

#### Parker N741-75

N741-75 is suitable for service in MIL-H-5606B and MIL-H-83282 where low temperature service is limited to -20°F. It is to be noted that where low temperature requirements are limited to the above that N741-75 has superior high temperature properties to N756-75 and N766-75. N741-75 is recommended for -20°F to +275°F temperature range.

Those customers who have been looking for a solution to their hydraulic system sealing problems are invited to evaluate these newest developments. Furthermore, the R&D Group would be interested in learning the results of these evaluations as further development work is planned in conjunction with Wright-Patterson AFB Materials Laboratory.

If there are any questions or suggestions concerning the data presented or test procedures used in this development work, please contact the Technical Service Centers or the R&D Group in Culver City, California.



DYNAMIC TEST PROCEDURE:

The dynamic tests discussed in this Technical Bulletin were developed under the Wright-Patterson AFB contract.

The initial program was based on dynamic testing using a rod type hydraulic system. In the latter studies it was extended to the use of a piston type system as this system was found to be more suited to determination of true low temperature sealing characteristics.

The basic test program on both piston and rod system consisted of the following cycle.

- a. Installation of test seal and room temperature soak for 18-24 hours.
- b. Initial low temperature pressure check at -65°F and -40°F and 2000 psig.
- c. Dynamic cycling was commenced and the temperature raised to 275°F. Cycling continued for 8 hours at 275°F using 50/3000 or 4000 psig. For the rod systems the stroke distance was varied throughout the test period (2", 1" and 1/2"). For the piston system a standard 2" stroke was used.
- d. Leakage rates throughout both low and high temperature cycles were monitored.
- e. The remainder of the one week cycle consisted of a high temperature aging at 275°F with 50 psig.
- f. Items b) through e) were repeated until an accumulated 1000 hours at 275°F or failure at high temperature were obtained.

DYNAMIC PROPERTIES OF LOW TEMPERATURE NITRILE COMPOUNDS

The following data is a summary of Dynamic Tests run under the Wright-Patterson AFB contract.

Compound	Test	Test		Test Fluid	Back-ups	Test Result
		Temperature Range	Pressure Range			
N304-7	Rod	-65 to +275°F	50-1500 psig	MIL-H-5606B	None	Failed after 457 hours @ 275°F, 65,200 cycles.
N304-7	Rod	-65 to +275°F	50-3000 psig	MIL-H-5606B	Nonfilled Teflon	Failed after 754 hours @ 275°F, 114,000 cycles.
N304-7	Piston	-65 to +275°F	50-3000 psig	MIL-H-5606B	Filled Teflon	Failed after 500 hours @ 275°F, 75,000 cycles.
N756-75	Rod	-65 to +275°F	50-3000 psig	MIL-H-83282	Filled Teflon	Passed 1,000 hrs @ 275°F 150,000 cycles.
N756-75	Rod	-65 to +275°F	50-4000 psig	MIL-H-5606B	Filled Teflon	Passed 1,000 hrs @ 275°F 150,000 cycles.
N756-75	Piston	-65 to +275°F	50-3000 psig	MIL-H-5606B	Filled Teflon	Completed 1,000 hr test @ 275°F. Some low temperature leakage recorded near end of test.
N766-75	Rod	-65 to +275°F	50-3000 psig	MIL-H-5606B	Filled Teflon	Passed 1,000 hrs @ 275°F 150,000 cycles.
N766-75	Rod	-65 to +275°F	50-3000 psig	MIL-H-83282	Filled Teflon	Passed 1,000 hrs @ 275°F 150,000 cycles.

THIS REPORT HAS BEEN DELIMITED  
AND CLEARED FOR PUBLIC RELEASE  
UNDER DOD DIRECTIVE 5200.20 AND  
NO RESTRICTIONS ARE IMPOSED UPON  
ITS USE AND DISCLOSURE.

DISTRIBUTION STATEMENT A

APPROVED FOR PUBLIC RELEASE,  
DISTRIBUTION UNLIMITED.

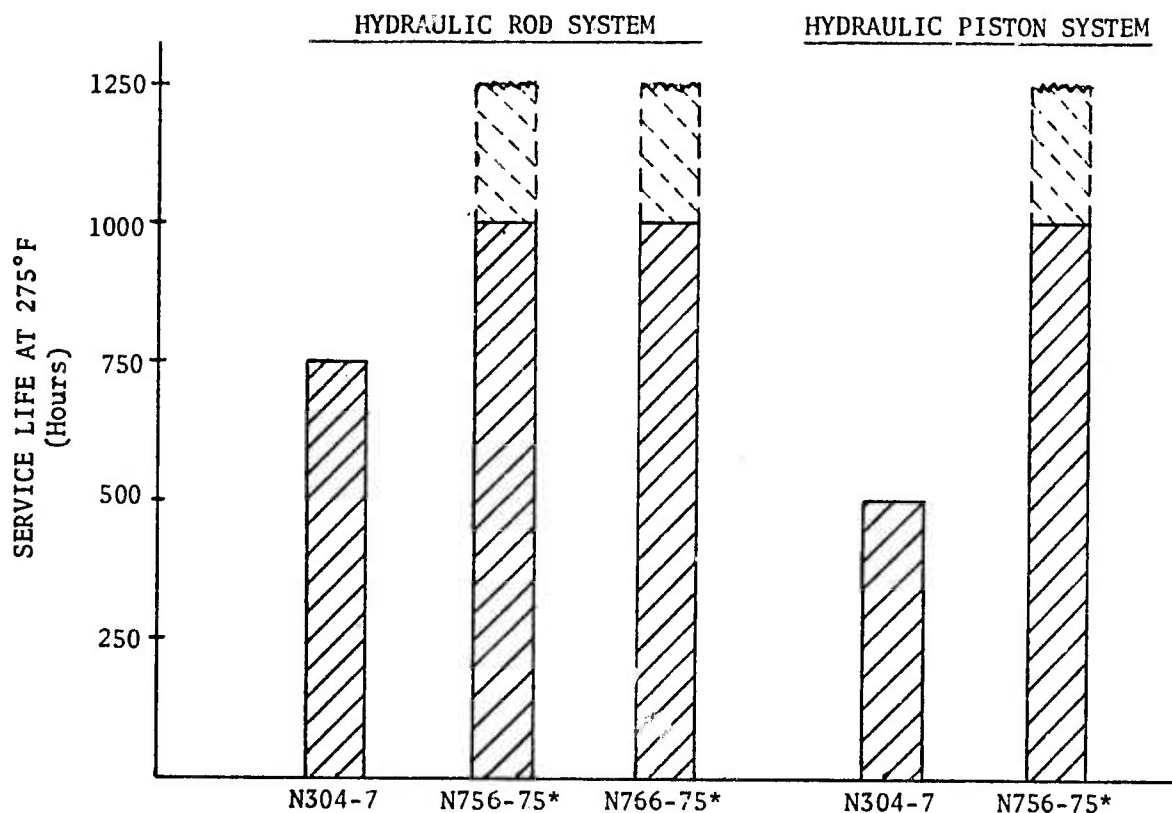

\*Tests terminated after 1000 hours at 275°F  
Dotted lines indicate predicted service only.

CONCLUSIONS:

1. There is a significant difference between the aging characteristics of nitrile compounds in MIL-H-5606B and MIL-H-83282. N304-7 which softened 15 points and has a volume swell of 15.8% in MIL-H-5606B, had a hardness increase of 5 points and shrinkage of 2.4% in MIL-H-83282.
2. Dynamic testing of N304-7 has shown failure after approximately 750 hours at 275°F on a rod test and 500 hours on a piston test. On the piston test high compression set and age hardening resulted in low temperature leakage after 300 hours at 275°F.
3. N756-75 was found to have the best dynamic properties. While it does not have the best compression set or the highest modulus, it has been shown on the long term rod test to have excellent wear properties. Further tests on the rod and piston test rigs are presently underway. N756-75 has been shown to be suitable for service in MIL-H-5606B and MIL-H-83282 fluid for -65°F to +275°F service. It is the recommended compound for the replacement of N304-7, considering all of the service requirements.

4. N766-75 has also shown excellent dynamic properties. 1,000 hour tests on the rod test rig have been successfully passed in both fluids. N766-75 was developed for -40°F service in MIL-H-83282. It is also suitable for use with MIL-H-5606B as tests have shown that it sealed at -65°F in the rod fixture. It is expected to be marginal at temperatures below -40°F, however, for other design applications.
5. Parker N741-75 and N304-7 have been shown for comparison purposes. It can be seen that the new nitrile compounds, N756-75 and N766-75, have retained the low temperature properties of N304-7 but have significant improvement in compression set resistance and aging characteristics. This is particularly noticeable when tested in fluids.

N741-75 has been shown to be an excellent compound for sealing MIL-H-5606B and MIL-H-83282. It has superior aging and set properties to the low temperature compounds at 275°F but it will only seal at approximately -20°F.

6. In examining the several dynamic tests which were evaluated, it became obvious that in systems which were operating in the 3000 psig/275°F range the back-up material and extrusion gap tolerances were critical. It was clearly shown in early experiments that nonfilled Teflon would not withstand pressures and temperatures in the 3000 psig/275°F range. For this reason it is strongly recommended that a filled Teflon back-up system be used. The materials used were Tetralon 720 from Tetrafluor Division of Royal Industries and Revonoc 18158 from C. E. Conover Division of Conover Industries.

<u>Compound Number</u>	<u>Parker N304-7</u> <u>B/N 124768</u>	<u>N756-75</u> <u>B/N 136514</u>	<u>N766-75</u> <u>B/N 131418</u>	<u>Parker N741-75</u> <u>B/N 132841</u>
------------------------	---	-------------------------------------	-------------------------------------	--

Original Physical Properties 6" x 6" x .075" slabs

Hardness Shore A, pts	76	74	74	72
Tensile psi	1750	2270	2670	2530
Elongation %	207	165	166	165
Modulus at 100% Elongation psi	767	965	1360	1190
Specific Gravity	1.26	1.22	1.26	1.23

Original Physical Properties 2-214 O-rings

Hardness Shore A, pts	74	74	73	76
Tensile psi	1600	1610	1970	2250
Elongation %	174	154	184	139
Modulus at 100% Elong. psi	692	752	796	1270

Aged Physical Properties  
Aged in Air 70 Hours @ 275°F x" x 6" x .075" slabs

Hardness, change, pts	88(+12)	83(+9)	83(+9)	78(+6)
Tensile, change, %	2020(+15)	1430(-37)	2130(-20)	2850(+13)
Modulus, change %	-	-	-	2160(+81)
Elongation change, %	87(-57)	84(-49)	53(-44)	124(-25)
Weight, change %	-3.8	-2.9	-1.8	-1.1
Compression Set 25% Deflection - Plied Sample % Original Deflection	52.0	42.0	26.8	25.2
Compression Set 25% Deflection - 2-214 O-rings % Original Deflection	77.1	49.1	40.8	17.1

Compound Number      Parker N304-7      N756-75      N766-75      Parker N741-75  
    B/N 124678      B/N 136514      B/N 131418      B/N 132841

Aged Physical Properties

Aged in MIL-H-5606B Fluid 70 hours at 275°F 6" x 6" x .075" slabs

Hardness, change, pts	61(-15)	64(-10)	70(-2)
Tensile, change, %	1060(-39)	1450(-36)	2120(16)
Elongation change, %	123(-41)	105(-36)	127(-23)
Modulus change, %	752(-2)	1320(+37)	1230(+3)
Volume change %	+15.8	+17.1	+12.7
Compression Set 25% Deflection 2-214 O-rings	40.0	31.4	7.6
% Original Deflection			

Aged in MIL-H-83282 Fluid 70 hours at 275°F 6" x 6" x .075" slabs

Hardness, change pts	81(+5)	77(+3)	72(0)
Tensile, change %	1110(-37)	1950(-14)	2310(-9)
Elongation, change %	78(-62)	110(-33)	127(-23)
Modulus, change %	-	1600(+65)	1330(+12)
Volume, change %	-2.4	+1.9	+6.0
Compression Set 25% Deflection 2-214 O-rings	61.9	46.7	14.3
% Original Deflection			

Low Temperature Properties

Temperature Retraction TR-10 °F	-49	-52	-2
---------------------------------	-----	-----	----

APPENDIX 111

REPORT 03-257 - Rev. A March 21, 1973

DEVELOPMENT OF THE BACK-UP RINGS FOR HIGH PRESSURE, HIGH TEMPERATURE SEALS

TEST PROGRAM

1.0 INTRODUCTION

- 1.1 The test program which is outlined below is the first of a series of tests, which will be performed to develop a new line of Back-up Rings. Anti-extrusion devices will be needed to permit a continuous operation of heat resistant O-Rings at temperatures up to 400°F and under pressures reaching 4000 psi.

The above requirements exceed the thermal potential of most existing plastics except of some very expensive polyimides and polyaryl-sulfones. At temperatures where the physical properties of plastics are considerably reduced the retainers are subjected to high stresses, distortion, thermal expansion wear and extrusion.

The success or failure of retainers operation under such conditions depends on the correct establishment and on the rigorous maintenance of the critical fits.

- 1.2 An examination of components retrieved from a previous test, revealed that in many cases the failure was due to mismatch of the test components.

In order to be in a better position to analyze Back-up Ring performance each program issued in connection with this job will include a table listing the critical dimension and tolerances of the components to be tested, their fits at assembly and their anticipated fits during the operation (See Table 1). Such a table would provide a check list for the initiator of the program assuring him that he had done his homework. It would also promote a more meaningful participation of the test Technician in the development activities providing him with easy means of checking the correctness of the assembly and of discovering discrepancies which still might sneak in undetected. The above method should result in considerable savings of the test time and costs.



2.0 MODIFICATION OF THE CHEW TEST RIG.

2.1 The O.D. of the groove in the gland of the chew rig used for the test performed in July 1972 was 1.262 dia instead of 1.241 +.002 dia as in MIL-G-5514. Consequently the

-.000  
O-rings were mounted with the initial squeeze of 3% to 8% instead of 9% to 16% squeeze. Since this chew test rig has only been used for comparative purposes, the effect of the initial squeeze is insignificant when the O-rings are operating at 3000 psi. Thus the results of the above test can be considered valid as far as the O-rings are concerned. In case of retainers however, the operation of which is affected by their fits in the gland, the results of the above test can not be accepted as fully reliable.

2.2 The Chew Rig modified for this program retains the following components:

- 2.2.1 One Body ML 10000 H-05261 Rev. A
- 2.2.2 Two Retainer-Spacers ML 10000 H-0555
- 2.2.3 Two Snap Rings
- 2.2.4 One Shaft ML 10000 H - 0444-1
- 2.2.5 The Drive, the fluid pressurization system etc.

2.3 The following are the new components.

- 2.3.1 Two Chew Test Rig Glands ML 1256 Rev. A.
- 2.3.2 Two Back-Up Plates ML-1265
- 2.3.3 Two Spacers ML-1257

2.4 The static O-rings and the wipers will be retained as a part of the design but their material must be checked for resistance to the temperatures specified for the particular tests.

2.5 The O.D. of the groove of the Chew Test Rig Gland ML 1256 Rev. A is the same as the cylinder dia in the MIL-G-5514F specification, as the cylinder dia meter of the test fixture #2 and as the groove O.D. of the fixture #1.

The dia of the existing Chew Rig Shaft is larger by 0.002 than the dia specified in MIL-G-5514 and is by 0.0035 larger than the dia of the shaft in the fixture #1.

The corresponding bores in the gland MIL-1256 Rev. A and in the back-up Plate ML-1265 have been adjusted to obtain the correct operational clearances between these components.

2.6 Prior to the test the following operations are to be performed.

2.6.1 Check and record on a set of prints the true dimensions

of the new components.

2.6.2 Scribe at the face of the gland ML-1256 Rev. A the true dimension of the groove O. D. 1.241  $\pm$ .002  
-.000

2.6.3 Assemble the chew test rig without the O-rings, the Retainers and the Wipers and check for alignment and for the free movement of the shaft.

2.6.4 Because the coefficient of the thermal expansion of the cast iron of which the glands ML-1256 Rev. A and the back-up Plates ML-1263 were made is of the same order as that of the carbon steel the fits between the components of the rig will not change with temperature.

3.0 TEST NO.1 A SHORT RUN IN THE CHEW TEST FIXTURE AT 275°F

3.1 The purpose of this test is the evaluation of the performance (wear, extrusion) of the Retainers as per MS 27595-214 (dimensionally) made of:

- 3.1.1 Virgin Teflon
- 3.1.2 Tetralon 720

3.2 The following are the test conditions:

- 3.2.1 V747-75 O-rings are to be used
- 3.2.2 Test Fluid: MIL-H5606C Hydraulic Fluid
- 3.2.3 Test Fluid Pressure: 4000 psi
- 3.2.4 Test Fluid Temperature 275°F
- 3.2.5 Cycle rate 60 c.p.m.
- 3.2.6 Operation Time: 6 hours before inspection of the tested components. The test should be stopped in case of a substantial fluid leakage.

3.3 THE ASSEMBLY PROCEDURE

With the Glands ML 1256 Revision A assembled with the pertinent static O-rings in the Pod ML 10000 H-0526-1 mount the following components in the gland groove on the Pod side marked NO. 1

- 3.3.1 The Spacer ML-1257
- 3.3.2 The V747-75 O-ring
- 3.3.3 The Teflon MS27595 214 Retainer

- 3.3.4 Use the assembly tool ML-1264 to protect the retainer from nicking when assembling it with the interference fit in the groove.
- 3.3.5 Mount the ML 1000H-0555 Retainer-Spacer with the wiper
- 3.3.6 Secure the assembly with the Snap Ring.
- 3.3.7 Mount the components in the opposite gland at the same sequence substituting the Teflon Retainer with the Tetralon 720 Retainer.

3.4 THE TEST PROCEDURE

- 3.4.1 Check the assembly for leakage at room temperature
- 3.4.2 Operate the rig at the cycling rate of 60 c.p.m. at 4000 psi fluid pressure and at 275°F temperature for 6 hours. The test shall be stopped if a substantial leakage develops.
- 3.4.3 The program for the tests to follow will be established upon the results of this test and of the subsequent inspection of the tested components.

# Parker SEAL COMPANY

CULVER CITY, CALIFORNIA

REPORT: 03-257 Rev A

PAGE: 02

POSITION	DESCRIPTION	DIMENSION
1.	Gland ML 1256 Rev. A. Groove O.D.	1.241 ± .002
2.		1.241
3.	Back-up Plate ML 1263 I.D.	1.004 ± .001
4.		1.004
5.	Shaft ML-10000H-0444-1 DIA	1.000
6.	Diametral clearance between the Back-up Plate (Pos.4) and the shaft (Pos.5)	0.004
7.	Width of the groove in the gland (Pos.2)	0.309 -0.310
8.	Squeeze of the V757-75 O-ring	11% - 15%
9.	Teflon Retainers per MS 27595-214	1.016 ± .001
10.		1.251 to 1.257
11.	Interference fit between the gland groove O.D. (Pos. 2) and the Teflon Retainer O.D. (Pos. 10)	0.010 to 0.016
12.	I.D. of the Retainer (Pos. 9) reduced due to the interference fit as per (Pos. 11)	1.007 to 0.999
13.	Diametral clearance between the reduced I. D. of the Retainer (Pos. 12) and the shaft dia (Pos. 5)	-.007CL 0.001 INT
14.	Tetralon 720 Retainer's 74009-1 O. D.	1.256
15.	I. D.	1.018
16.	Interference fit between the gland groove O. D. (Pos.2) and the Tetralon Retainer O. D. (Pos. 14)	0.015
17.	I. D. of the Tetralon retainer reduced due to the interference fit as per (Pos. 16)	1.003
18.	Diametral clearance between the reduced I. D. of the Retainer (Pos. 17) and Shaft (Pos. 5)	0.003
19.	Reduction of the diametral clearance fit (Pos. 13 and Pos. 18) due to the thermal expansion of the width of the Teflon and Tetralon Retainers at 275°F and 400°F	NEGLIGIBLE

TABLE 1

NOTE: This Table shall be used in conjunction with the Dwg. ML-1267

# Parker SEAL COMPANY

CULVER CITY, CALIFORNIA

APPENDIX IV

REPORT: 03-258

PAGE: 103

REPORT 03-258 DYNAMIC ROD SEAL EVALUATION-COMPOUNDS AFE-XN1925-25  
AND AFE-XN1925-33 IN MIL-H-5606B/3000PSIG/275°F - June 15, 1973

## 1.0 INTRODUCTION

1.1 This report is based on the results of inspection of the test specimens retrieved after completion of two 1000 hour tests performed between January 12 and March 14, 1973. These tests were performed under the AFML contract No. 33615-71-6-1304 on the Rod Seal Test Fixture #1.

Two O-ring compounds were tested. The XN1925-25 O-rings were mounted on the Yokes #1 and #2 while the XN1925-33 O-rings were mounted on the Yokes #3 and #4.

Tetralon 720 back-up rings made to the dimensions of the MS 27595-214, retainers were used with the dynamic seals while tetrafluoroethylene retainers to MS 27595-218 were used to back-up the static O-rings.

Hydraulic fluid per MIL-H-5606B was used in all tests.

## 2.0 PURPOSE OF THE INVESTIGATION

2.1 The purpose of the investigation discussed in this report was to check the conditions of the aforementioned seals and in particular to determine the causes of a rapid and irregular wear of Tetralon 720 back-up rings. This wear in turn affected the operation of the O-rings causing their local destruction.

The development of temperature resistant back-up rings will be the subject of a separate program. However, the 1000 hour tests performed under simulated operational conditions and within a wide range of pressures and temperatures provided valuable information as to the behavior of the back-up rings which are essential components of seal systems tested.

Such information will permit starting the back-up rings development program from a solidly established base, a fact of special importance because of limited development time and funds allotted for this program. The abbreviated test on the chew ring is of limited value for the evaluation of the back-up rings and would never be a substitute for the full 1000 hour tests.

A widespread damage to an O-ring can be caused by a faulty back-up ring. This sometimes could confuse the picture and might unjustly disqualify a compound otherwise perfectly suitable for operation under the conditions simulated by the test.

Reference is made here to the Report 05-249 and to its Addenda 1 and 2. The basic report analyzed the failures of the tested cylinder seals, pinpointed the causes of these failures and recommended the

necessary modifications. The test reported in Addenda 1 and 2 confirmed the findings of this analysis and demonstrated that the application of the recommended modifications eliminated the failures of the O-rings. The present report can be considered as a counterpart of the Report 05-249. It investigates the malfunctioning of the back-up rings, which cause a premature wear of the rod seals.

It has been a common experience that the specimens retrieved after the test, examined by several people, then stored in bags, boxes, etc., have a tendency of disappearing as fast as their memories. To avoid this misfortune the specimens were examined immediately after completion of the test and the result of this examination was recorded in Appendix 2 of this report.

- 2.2 The comments and recommendations which are usually put at the beginning of each report for the benefit of those who are not interested in technicalities of the tests have been moved to Paragraph 6.0. These comments and recommendations are based on the results of the "Design and Operational Analysis," Paragraph 5.0, and could not be fully understood without the information contained in Paragraph 5.0.

### 3.0 TEST PROCEDURE

- 3.1 Both tests discussed in this report followed the procedure adopted for all 1000 hour tests under this program. The sequence of operations of the procedure is shown on Pages 9 through 11 of the Report No. 05-249, Addenda 2.

To permit correlation between the behavior of the tested specimens and their conditions observed during the after-test inspection, the photostatic copies of the original test data sheets are enclosed to the present report as Appendix 1.

### 4.0 SUMMARY ON INSPECTION OF TESTED SPECIMENS

- 4.1 The conditions under which the O-rings and the back-up rings were operated can be determined from the Table 1 and Figure 1. Table 1 specifies the basic diameters of the glands and permits determination of clearances and of O-ring squeezes.

Table 2 and Table 3 show the actual (measured) depths of the glands and widths of the back-up rings before and after test. These dimensions were used for determination of wear of the back-up rings and of their fit in the glands.

The results of inspection of each O-ring and back-up ring after test are specified in Appendix 2. The following is the summary of the conditions of the seal components inspected after tests.

- 4.2 The dynamic O-rings took some permanent set and formed at the I.D. an edge pointing outwards.

The XN1925-25-214 O-rings mounted in the Yokes #1 and #2 were brittle, cracking when bent. Erosion was noticeable at the aforementioned edges, the erosion being due to local cracking and chipping of elastomer.

The XN1925-33-214 O-rings mounted in the fixtures #3 and #4 remained flexible. No erosion was noticeable at the edges. The portions of the O-rings touching the rod showed high gloss.

- 4.3 The static O-rings made of the same compound as the pertinent dynamic O-rings remained flexible and besides a moderate set did not show any signs of deterioration.
- 4.4 The inboard Tetralon dynamic back-up rings were slightly warped side-wise, but did not show wear.
- 4.5 The outboard Tetralon dynamic back-up rings showed various amounts of wear at the I.D. (see Table 2 and Table 3). In the extreme cases, the wear amounted to 0.034 (Yoke #1) and to 0.050 (Yoke #4). The causes of this unusual amount of wear are explained in Paragraph 5.0 "Design and Operational Analysis."
- 4.6 The static Tetrafluoroethylene Retainers adapted themselves well to their respective grooves and did not show extrusion.
- 4.7 The O-rings used as wipers were made of the same compound as the pertinent dynamic and static rings. Being exposed to oxidation they all became brittle. The wipers were, however, structural parts of the yokes, not the test specimens. Their conditions should not therefore affect the evaluation of tested elastomers.

## 5.0 DESIGN AND OPERATIONAL ANALYSIS

- 5.1 The following is a tentative analysis of the conditions under which the Tetralon 720 back-up rings were assembled and were operated in the Shaft Seal Fixture Type I.

Yokes #3 and #4 were used in the test subject to this analysis. In view of the fact, however, that the four yokes were machined within close tolerances, the actually recorded dimensions are representative for all the four yokes.

TETRALON 720 BACK-UP RING DIMENSIONS AS MEASURED:

O. D. (measured)	1.256
Width (measured)	0.119
I. D. (calculated)	1.018

AT ASSEMBLY:

Back-up ring O.D. (free)	1.256
O.D. of the Drawing 5718003 End Cap groove (measured)	<u>1.241</u>
Interference fit per Diameter	<u>0.015</u>
Back-up ring's I.D. reduced due to the above interference fit at O.D.	1.003
Rod Diameter (measured)	<u>0.996</u>
Diametral clearance between the back-up ring's I.D. and the Rod	0.007

When the back-up ring was pushed into the groove at assembly, its mean diameter 1.137 shrunk by 0.015 and its main circumference shrunk by  $0.015 \pi = 0.047$

Assuming that:

- A = cross section of the back-up ring =  $0.119 \times 0.05 = 0.00595$  square inch.
- L = mean circumference of the back-up ring =  $1.137 \pi = 3.57$
- $e_1$  = magnitude of shrinkage of the mean circumference = 0.047
- $E_1$  = compressive modulus of Tetralon 720 =  $6.6 \times 10^4 = 66000$
- $P_1$  = compressive load in the circumferential direction due to the shrinkage of the back-up ring

$$P_1 = \frac{e_1 A E_1}{L} = \frac{0.047 \times 0.00595 \times 66000}{3.57} = 5.16 \text{ lbs.}$$

In order to remain flat, the back-up ring must remain pressed against the supporting side of the groove.

The compression of the back-up ring in the circumferential direction would cause its expansion crosswise. With the assumption of 0.4 as Poisson's Ratio for Tetralon, this expansion would reduce the back-up ring I.D. by some 0.001.

When the fixture was operated at elevated temperatures another source of compressive stress was created in the back-up ring because of the differential between the coefficient of the linear thermal expansion of Tetralon 720 and of the carbon steel of which the fixture was made.



**Parker SEAL COMPANY**  
 CULVER CITY, CALIFORNIA

REPORT: 03-258

PAGE: \_\_\_\_\_

The following were the coefficients of thermal expansion of the materials involved:

Tetralon 720	0.0000650 inch/inch/°F
Carbon Steel	0.000063 inch/inch/°F
Differential coefficients of Expansion	$\frac{0.0000587 \text{ inch/inch/°F}}$

When the yoke was heated from 75°F to 275°F the shaft diameter would expand by:

$$0.996 \times 0.000063 \times 200 = 0.0012$$

The groove 1.241 O.D. should expand proportionally more. However, the Yoke was heated mainly by the hot oil circulated through the hollow shaft. Heating of the Yoke body by radiation from the remote electric heaters was less efficient, and the temperature of the body containing the groove was lower than the temperature of the shaft.

For the simplicity sake it has been assumed here that the groove O.D. expanded as much as the shaft Diameter, so that the depth of the gland did not change.

When the temperature of the Yoke rose by 200°F, the back-up ring tended to expand circumferentially by  $1.13 \times 0.0000587 \times 200 = 0.042$ .

Because this expansion was made impossible by the restraint of the groove O.D., an additional compression stress  $P_2$  was built up circumferentially in the back-up ring.

The compressive modulus of Tetralon 720 was reduced here, due to the increase of Tetralon temperature by 200°F. The exact amount of this reduction could not be determined due to the lack of pertinent experimental data. It was, therefore, arbitrarily assumed as being 25% of the compressive modulus at room temperature, thus bringing the  $E_2$  to 49500 psi.

With  $e_2$  being 0.042 the additional compression load in the circumferential direction of the back-up ring due to the thermal expansion of the rig components would be:

$$P_2 = \frac{e_2 A E_2}{L} = \frac{0.042 \times 0.00595 \times 49500}{357} = 3.47 \text{ lbs.}$$

At the same time, however, the initial compression load of 5.16 lbs. due to the interference fit would decrease by 25% because of the decrease of  $E_1$ . Thus the total circumferentially directed compressive load in the back-up ring should be:

$$P \text{ Total} = 3.86 + 3.47 = 7.33 \text{ lbs.}$$

The purpose of the above analysis was to attract attention on the stress problems, which the back-up ring designer has to face, and to indicate how the design and functional parameters would affect the stress in the back-up rings.

- 5.2 The figures determined above should be considered as approximate only indicating, rather, the order of magnitude of forces and stresses which could be expected to occur.

The following factors would affect the results of this analysis:

Some of the parameters entering the equations had to be assumed and some are based on data which seemed to be questionable. Particularly, the compressive modulus for Tetralon 720 quoted by the manufacturer as  $6.6 \times 10^4$  seemed to be rather low considering the fact that the compressive modulus for unfilled Teflon was given as  $6.0 \times 10^4$ .

Each plastic material is subject to creep causing relaxation of stress. The creep is a function of the magnitude of stress, duration of exposure, temperature, etc. In the case examined, the creep was restricted in the circumferential direction but was free radially. Under the test conditions, where the back-up ring was repeatedly subjected to considerable temperature changes while the rate, the magnitude and duration of these changes could not be determined with accuracy, the magnitude of stress relaxation could not be evaluated.

The inspection of the back-up rings retrieved after completion of the test reported, provided, however, a positive evidence that the back-up rings operated under a substantial circumferential stress.

Let us examine the evidence:

The slenderness of the tested back-up rings was such that the circumferential stress would cause buckling or warping of the rings sidewise, unless the rings were adequately supported.

Such a support was missing in case of the inboard back-up rings. These rings were mounted with a substantial side clearance and this clearance was increased at each pressure cycle, which compressed and flattened the O-rings. The inboard back-up rings being not leakproof were affected little or not at all by the pressure pulsations.

All inboard back-up rings retrieved after the test reported here were warped, while maintaining their dimensions and showing practically no wear. Buckling was the means by which the circumferential stress was relieved.

A different situation existed, however, in case of the outboard back-up rings.

It had been demonstrated at the beginning of this analysis that assembling of a 1.256 O.D. back-up ring in a 1.241 O.D. groove shrunk the ring's I.D. to 1.003.

Expansion of the width of the back-up ring following the Poisson's Ratio Theorem reduced the ring's I.D. by 0.001.

The thermal expansion of the back-up ring width which amounted to 0.001 per side, reduced the ring's I.D. by a further 0.002.

With another reduction of the ring's I.D. by 0.001 due to the lateral expansion of the ring thermally shrunk in the circumferential direction, the final diametral clearance between the back-up ring's I.D. and the rod was reduced to 0.003.

With the diametral clearance between the rod and the End Cap of order of 0.004 to 0.005, the maximum off-center position of the rod could not exceed 0.0025.

So even with a certain spreading of the back-up ring sidewise due to the repeated pressure application on the O-ring, no substantial, if any, interference between the back-up ring's I.D. and the rod could be anticipated. Yet, all outboard back-up rings inspected after test showed various amounts of wear on the I.D.

In all cases the wear was on one side of the ring reducing its initial width of 0.119 to 0.066 in one case and to 0.033 in the most extreme case. (See Table 2 and Table 3) The worn segment of the latest ring collapsed inwardly as shown on Figure 6. In all other cases the rings' outside diameters remained round and showed no signs of wear.

5.3 The following is a tentative explanation of this unusual pattern of wear observed on the outboard back-up rings.

As long as the test rig was under high pressure the O-rings kept the outboard back-up rings flat against the side walls of the grooves. When the fluid pressure was relieved at every second stroke, the support provided by the O-rings was lost and the moving rod pulled the O-rings and in some cases the outboard back-up rings away from the groove wall. This created the situation where the back-up rings could expand circumferentially by buckling sidewise.

The distortion of the back-up rings by buckling caused some of their circumference to press hard towards the moving rod producing a local wear.

Since buckling started at a location where the most appropriate conditions existed for it, it would be logical to assume that the buckling pattern was repeated at each second stroke. The load reduction and weakening of the ring cross-section by wear further contributed to maintenance of the buckling pattern.

The warped and locally worn back-up ring might in some locations lose contact with the bottom of the groove, thus opening a gap at the O.D. When the O-ring pushed the warped back-up ring into its initial position at the pressure stroke, a pinching and nibbling of the O-ring might occur. The inspection of the O-rings after test showed indeed that in the cases where the outboard back-up ring was worn at the I.D., a local erosion was found on the O-ring not only at its I.D. but also at the O.D. facing the outboard back-up ring. Thus the wear of the back-up rings was a governing factor in the operational life-span of the O-ring.

#### 6.0 COMMENTS AND RECOMMENDATIONS

- 6.1 In the analysis in 5.0 the stresses and strains of a Tetralon 720 back-up ring machined to the dimensions of the MS27595-214 Standard and mounted in a gland per MIL-G-5514F-214 were investigated within a temperature range of R.T. to 275°F.

The investigation revealed that the circumferential compression stress caused by the interference fit between the O.D. of the back-up ring and the bottom of the groove in which the back-up ring was mounted was higher than the stress caused by the differential linear thermal expansion between the Tetralon back-up ring and its steel housing when the test rig was heated to 275°F.

The 0.008 to 0.016 interference fit between the back-up ring to MS27595-214 and the groove to MIL-G-5514F-214 as well as the 0.017 to 0.021 clearance between the I.D. of the above back-up ring and the diameter of the standard rod could not be functionally justified and appeared to be a result of an overlooked error.

This dimensional discrepancy has been already recognized and the modification of the MS27595 is now being discussed by the SAE -A6 Fluid Power Technologies Committee. The proposed reduction of I.D. to  $1.003 \pm .002$  with the maintenance of  $W=0.118$  to  $0.120$  would reduce the fit at the back-up ring O.D. to 0.004 interference and to 0.006 clearance, while leaving 0.003 to 0.009 clearance between the back-up ring I.D. and the rod.

This should be a definite improvement. With a relatively high tendency to deformation of an unfilled Teflon the above dimensions might be correct. In case of plastics less susceptible to deformation than the unfilled Teflon the above back-up ring fits and particularly the clearance between the back-up ring I.D. and the rod should be checked. The shrinkage of the back-up ring I.D. at temperatures as low as -65°F should be investigated.

At the present time a 1000 hour test is being performed in the fixture #1 (rod) with the outboard back-up ring of Revonoc 18158 made to the drawing ML-1272.

The ML-1272 back-up ring was designed primarily for piston application and fits the fixture with 0.002 to 0.006 diametral interference at both the O.D. and I.D. The purpose of this interference was to provide an expendable material for the initial break-in of the piston back-up rings.

The test now in progress should indicate whether or not such interference fit would be excessive for the rod application and would cause buckling of the outboard back-up ring under some operational conditions, as described in the previous chapter.

- 6.2 The development of an ideal back-up ring will be a step by step procedure guided by the results of consecutive tests. The final form, or forms, of a back-up ring is difficult to predict since the 275°F operational temperature is only a stepping stone to the final specification requiring operation at 400°F and at 4000 psi pressure.

Besides investigation of plastics with improved temperature resistance, the following design alternatives might be investigated.

- 6.3 Back-up ring with increased thickness to prevent buckling under thermally induced circumferential stresses.
- 6.4 Back-up rings with skive cuts. It should be noted here that for a single skive cut back-up ring for one inch diameter rod the circumferential shift of the free ends may be of order of some 0.07 within the temperature range of -65°F to 275°F.
- 6.5 Entirely new type of back-up rings. The "T" Seal configuration is one of the possibilities.
- 6.6. The back-up rings made of materials having the coefficients of the linear thermal expansion of the same order as the coefficients of the metal components of the glands. That would possibly include metal back-up rings with antifriction ingredients to prevent seizure of the rings on the rod under adverse conditions. Such back-up rings would introduce entirely different functional problems, which will not be discussed here.

POS.	DESCRIPTION	INCH
1	D <sub>1</sub> Bore diameter in End Cap 5718003	1.000 +.001 -.000
2	D <sub>2</sub> Dynamic O-ring groove O.D. in End Cap 5718003	1.241 +.002 -.000
3	D <sub>3</sub> Wiper groove Dia in End Cap 5718003	1.241 +.002 -.000
4.	D <sub>4</sub> Diameter of shaft 5718005 cold (measured)	.996
5.	D <sub>4E</sub> = D <sub>E</sub> corrected due to the differential expansion of the internally heated shaft operated in the colder End Cap (assumed)	.997
6	D <sub>5</sub> Static O-ring groove O.D. in End Cap 5718003	1.491 +.002 -.000
7	D <sub>6</sub> Diameter of centering track in Body 5718002	1.489 +.000 -.001
8	D <sub>7</sub> Static O-ring groove I.D. in Body 5718002	1.248 +.000 -.002
9.	Diametral clearance between D <sub>1</sub> and D <sub>4</sub>	.004 to .005
10	Depth of the dynamic O-ring gland [0.5 D <sub>2</sub> -D <sub>4</sub> ]	.1225 to .1235
11	Squeeze of the dynamic O-ring	8.5% to 14.3%
12	Depth of the wiper gland [0.5 D <sub>3</sub> -D <sub>4</sub> ]	.1225 to .1235
13	Squeeze of the wiper O-ring	8.5% to 14.5%
14	Diametral clearance between D <sub>5</sub> and D <sub>6</sub>	.002 to .005
15	Depth of the static O-ring gland [0.5 D <sub>5</sub> -D <sub>7</sub> ]	.1215 to .1235
16	Squeeze of the static O-ring	8.5% to 15%
17	O.D. of Tetralon Retainer to MS27595 (measured)	1.256

TABLE 1

Design dimensions and fits of the glands for the dynamic and static seals in the Fixture #1.

Note: The dimensions D<sub>1</sub> through D<sub>7</sub> are shown on Figure 1.

<u>Description</u>	Yoke #1		Yoke #2	
	Side Opposite the drive	Side Towards the drive	Side Opposite the drive	Side Towards the drive
Depth of gland	.123	.123	.123	.123
Width of the Tetralon 720 outboard back-up ring				
a) New ring	.119	.119	.119	.119
b) After test	.086 to .118	.108 to .118	.115 to .123	.110 to .125
Clearance between the gland depth and the width of the back-up ring				
a) At assembly	.004	.004	.004	.004
b) After test	.037 to .005	.015 to .005	.008 to .000	.013 to-.002

TABLE 2

Depth of glands and widths of the outboard Tetralon 720 back-up rings of the dynamic rod seals (as measured). Clearances between the above components at assembly and after the 1000 hours test.

Description	Yoke # 3		Yoke # 4	
	Side Opposite the drive	Side Towards the drive	Side Opposite the drive	Side Towards the drive
Depth of gland	.123	.123	.123	.123
Width of the Tetralon 720 outboard back-up ring				
a) New ring	.119	.119	.119	.119
b) After test	.108 to .114	.110 to .116	.073 to .115	.114 to .117
Clearance between the gland depth and the width of the back-up ring				
a) At assembly	.004	.004	.004	.004
b) After test	.015 to .009	.013 to .007	.050 to .008	.009 to .006

TABLE 3

Depths of glands and widths of the outboard Tetralon 720 back-up rings of the dynamic rod seals (as measured). Clearances between the above components at assembly and after the 1000 hours test.



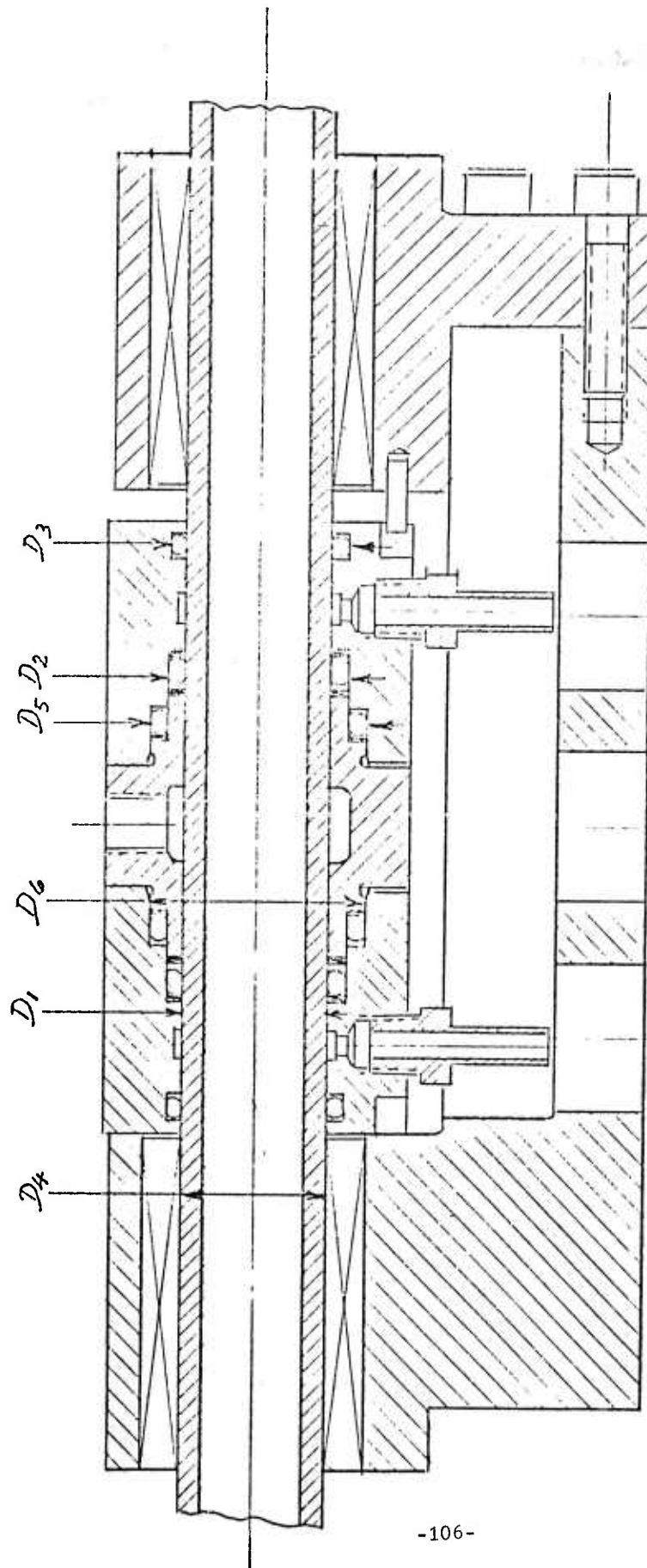

FIG. 1.

LOCATION OF DIMENSIONS SPECIFIED IN TAB. 1.

Report No. 03-258

APPENDIX 1

Test Data Sheets

Note: Test Data Sheets Available if Required

-----

Report No. 03-258

APPENDIX 2

Detailed description of the condition of  
the seal components inspected after tests.

Note: Available if required.

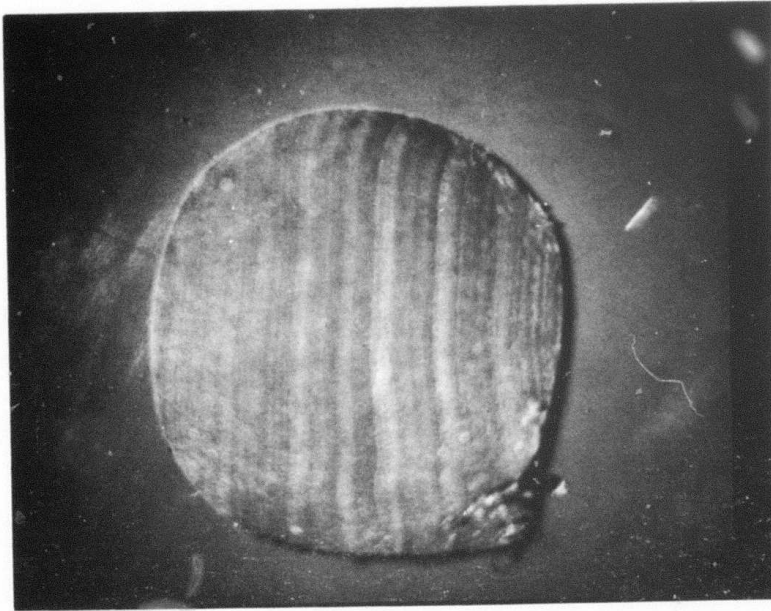

Figure 2.

Cross Section of the XN1925-25 O-ring  
Yoke #1 Side Opposite to Drive  
Appendix 2. - 1.1.1

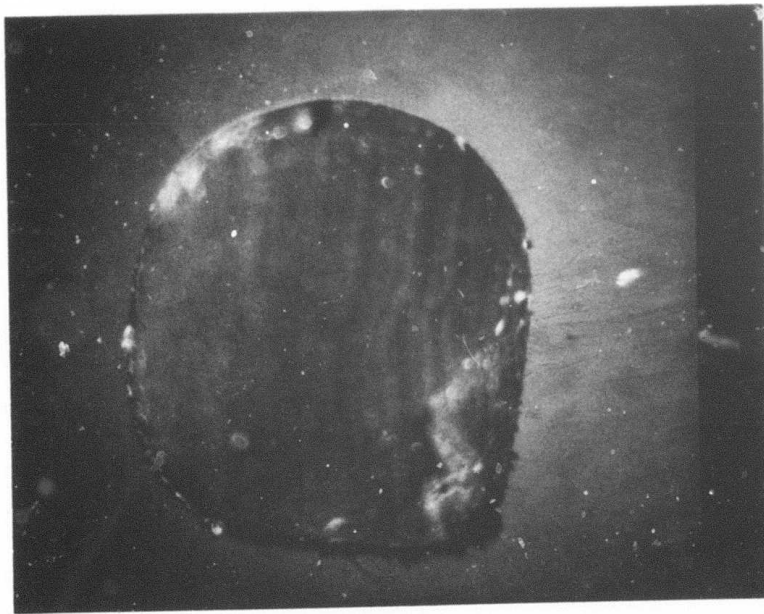

Figure 3.

Cross Section of the XN1925-25 O-ring  
Yoke #1 Side Towards the Drive  
Appendix 2. -1.2.1

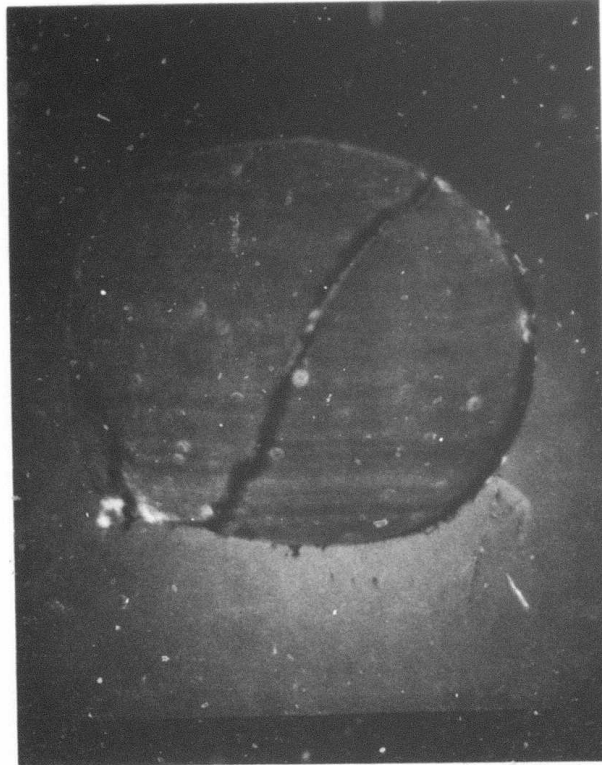

Figure 4.

Cross Section of the XN1925-25 O-ring  
Yoke #2 Side Towards the Drive  
Appendix 2. - 2.2.1

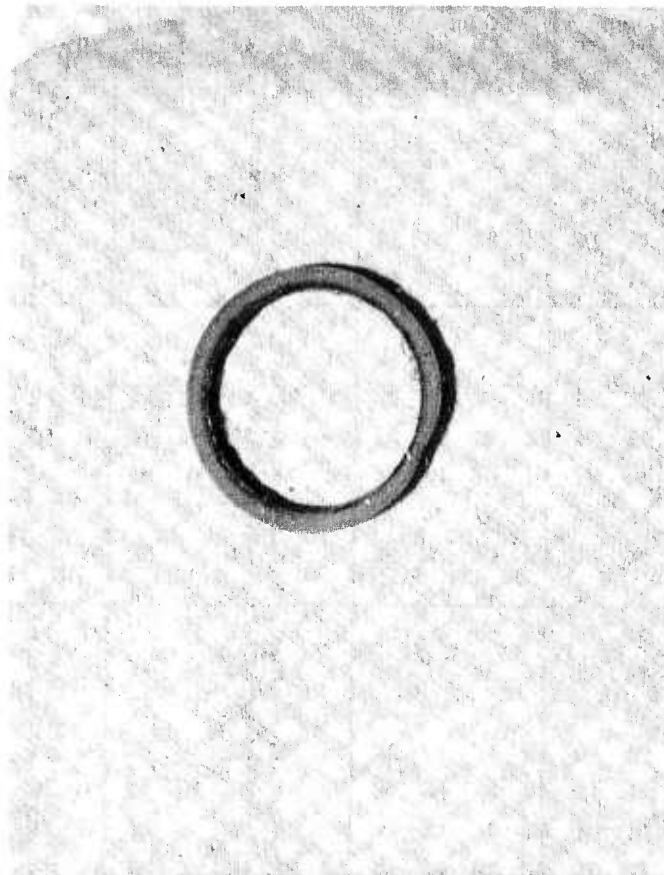

Figure 5.

Tetralon 720 Outboard Back-up Ring  
Yoke #4 Side Opposite to Drive  
Appendix 2. - 4.1.2

DESCRIPTION	YOKE #1		YOKE #2	
	Side Opposite the Drive	Side Towards the Drive	Side Opposite the Drive	Side Towards the Drive
OUTBOARD BACK-UP RING MATERIAL Back-up Ring Drawing Number	REVONOC 18158 ML-1272	REVONOC 18158 ML-1272	REVONOC 18158 ML-1272	REVONOC 18158 ML-1272
O.D. of Housing Groove (dwg)	1.241 +.002 - .000	1.241 +.002 - .000	1.241 +.002 - .000	1.241 +.002 - .000
O.D. of Back-up Ring (measured)	1.250 - 1.252 .1225 - .1235	1.250 - 1.252 .1225 - .1235	1.250 - 1.252 .1225 - .1235	1.250 - 1.252 .1225 - .1235
Depth of Gland	.125 - .126	.125 - .126	.125 - .126	.125 - .126
Width of the outboard back-up ring	.117 - .120	.116 - .120	.110 - .116	.107 - .116
a. New ring				
b. After Test				
Clearance or interference fit between the gland depth & the width of the back-up ring .	.0015-.0035 interf. .002 -.006 clear.	.0015-.0035 interf. .002 -.006 clear.	.0015-.0035 interf. .013 -.016 clear.	.0015-.0035 interf. .005 -.007 clear.
a. At assembly				
b. After test				
Remarks	Extruded irregular fringes at the outboard side of the I.D. Small elevated ridges upstream. Back-up ring fiat.	Similar appearance as on the side opposite to drive. Back up ring fiat.	Similar appearance as on Yoke #1. Back-up ring slightly warped.	Similar appearance as on Yoke #1. Back-up ring fiat.
a. Outboard back-up ring Revonoc 18158				
b. Inboard back-up ring of unfilled Teflon	Ring slightly warped with a substantial extrusion lip pointing upstream - away from the O-ring at I.D.	Similar appearance as on the side opposite to drive.	Smaller extrusion lip than on the Yoke #1 back-up ring.	Large extrusion lip at I.D. pointing away from the O-ring
c. Dynamic O-ring XN1925-33 compound	Flexible - no marks	Flexible - no marks	Flexible - no marks	Flexible - no marks

TABLE 1.

DESCRIPTION	YOKE #3		YOKE #4	
	Side Opposite the Drive	Side Towards the Drive	Side Opposite the Drive	Side Towards the Drive
OUTBOARD BACK-UP RING MATERIAL Back-up Ring Drawing Number	REVONOC 18158 ML-1272	REVONOC 18158 ML-1272	REVONOC 18158 ML-1272	REVONOC 18158 ML-1272
O.D. of Housing Groove (dwg)	1.241 +.002	1.241 +.002	1.241 +.002	1.241 +.002
O.D. of Back-up Ring (measured)	-.000	-.000	-.000	-.000
Depth of Gland	1.250 - 1.252	1.250 - 1.252	1.250 - 1.252	1.250 - 1.252
Width of the Outboard back-up ring	.1225 - .1235	.1225 - .1235	.1225 - .1235	.1225 - .1235
a. New ring	.125 - .126	.125 - .126	.125 - .126	.125 - .126
b. After test	.116 - .120	.115 - .118	.112 - .117	.078 - .115
Clearance or interference fit between the gland depth & the width of the back-up ring.				
a. At assembly	.0015-.0035 interf.	.0015-.0035 interf.	.0015-.0035 interf.	.0015-.0035 interf.
b. After test	.002 -.007 clear.	.004 -.008 clear.	.005 -.011 clear.	.007 -.045 clear.
Remarks				
a. Outboard back-up ring Revonoc 18158	Ring warped at the location of its min. width. Large fringes at the outboard I.D. small ridge inboard	Large fringes at the I.D. pointing outboard.	Ring slightly warped. Large fringes at I.D. pointing outboard.	Ring not round locally collapsed. Warped. Very long fringes firming locally into continuous lip.
b. Inboard back-up ring of unfilled Teflon	An extrusion lip locally at I.D. at the side opposite to the O-ring.	Appearance similar to the back-up ring at the side opposite to the drive.	Ring considerably warped & not round but almost no extrusion.	Broken in one place. Long extrusion strips, especially at the broken ends.
c. Dynamic O-ring XV1836-10 compound	Flexible - no marks	Flexible - no marks	Flexible - no marks	Narrow irregular wear marks locally. A shallow groove along the circumference slightly below the mean dia.

TABLE 2.



**Parker SEAL COMPANY**  
CULVER CITY, CALIFORNIA

REPORT: 03-258      REV: \_\_\_\_\_  
PAGE: \_\_\_\_\_

APPENDIX V11

REPORT 03-258 Addendum 11      EVALUATION OF PARKER COMPOUND V747-75  
AT 350°F/4000 PSIG/USING CAST-IRON/REVENOC 18158 BACK-UPS - NOV. 30, 1973

1.0 INTRODUCTION

1.1 In this report the operation of a rod seal back-up system is investigated. This system, consisting of a plastic and a metal back-up ring mounted in tandem, completed successfully a 1000 hours material evaluation test performed under the A.F.M.L. Contract No. F33615-C-1304. The present study is the continuation of the functional analysis of the O-ring back-up system reported in the Report No. 05-249 Addendum V.

2.0 BACKGROUND

2.1 The test run between July 25 and September 20, 1973 was performed under the following conditions:

2.1.1 Components Tested.

- 2.1.1.1 2-214 O-rings of the V747-75 compound.
- 2.1.1.2 ML-1294 Revonoc 18158 back-up rings  
ML-1285 Cast iron back-up rings.
- 2.1.1.3 2-214 O-rings of the V747-75 compound,  
installed as wipers.  
2-218 O-rings of the V747-75 compound,  
installed as static seals.

2.1.2 Test Fluid per ML-H-83282

2.1.3 Test Conditions

- 2.1.3.1 Fluid pressure range: 50 to 4000 psi
- 2.1.3.2 Temperature range: -65°F to 350°F

2.1.4 Test Procedure

- 2.1.4.1 Standard test procedure for a 1000 hours material evaluation test. The Test Data Sheets are enclosed as Appendix 1.

3.0 COMMENTS ON THE OPERATION OF THE BACK-UP SYSTEM

3.1 Reference is made to Report 05-249 Addendum V. In this report the operation of a plastic-cum-metal back-up ring system adopted to a piston seal was analyzed. The comments pertinent to the piston seal back-up system are valid for the rod seal back-up system with one exception. The increase of the width of the static gap at the side opposite to the direction of the lateral shift of the rod tends to push the metal back-up ring in the direction of the shift of the rod. This is illustrated in Fig. 3.

- 3.2 Figure No. 1 shows schematically a cross section of the rod seal back-up system indicating the End Cap 5718003, the Rod 5718005, and the cast iron Back-up ring ML-1285. The O-ring and the plastic back-up ring were omitted for simplicity sake. The diameters are the true ones as measured on the tested components.

Figure 2 specifies the gaps which would exist between the adjacent surfaces of the above components if these components were held in a strictly concentric position.

Figure 3 shows the gaps which would exist between the above components if the rod moved to its maximum off-center position in the direction of the arrow "A", and the cast iron back-up ring was pushed in the same direction by the prying action of the extrusion lip, as explained in the Report 05-249, Addendum V.

Figure 4 shows the gaps which would exist between the adjacent surfaces of the above components if the rod moved to its maximum off-center position in the direction of the arrow "A" and the cast iron back-up ring remained static with respect to the end cap.

- 3.3 The appearance of the plastic and metal back-up rings in the Pod #1 seems to indicate that the metal back-up rings assumed the position as per Figure 4 during the operation. The shiny wear marks along 1/6 to 1/3 of the inner circumference of the metal back-up rings point out that the rings were touching the rod. The almost uniform extrusion lips along the outer circumference of the plastic back-up rings would be in agreement with the static gap in Figure 4.

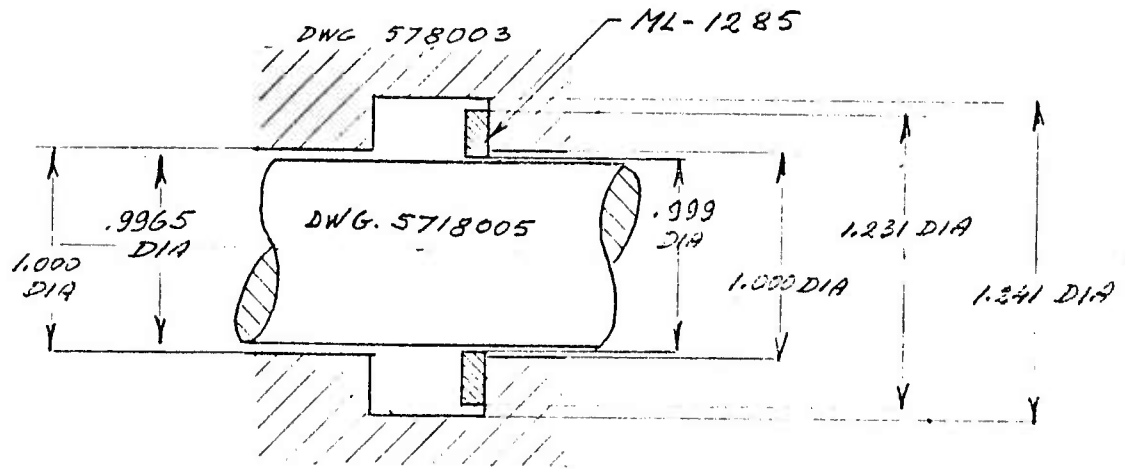

FIG. 1.

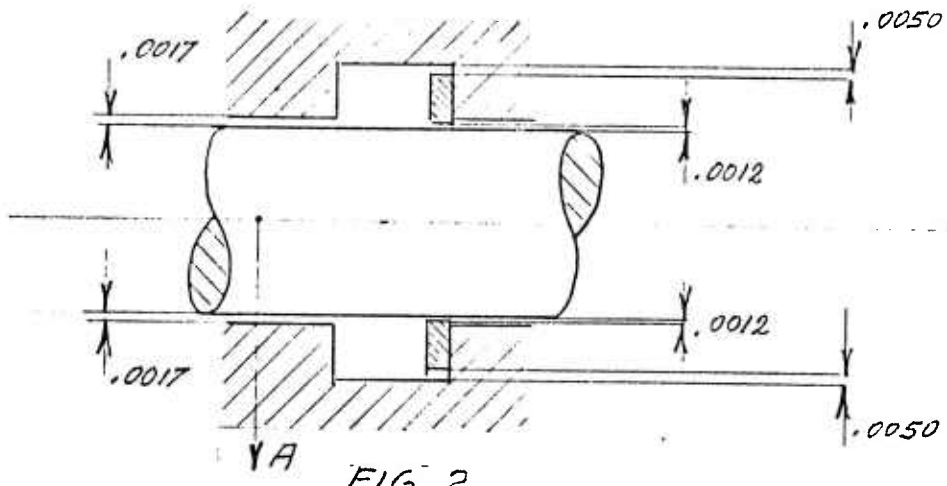

FIG. 2

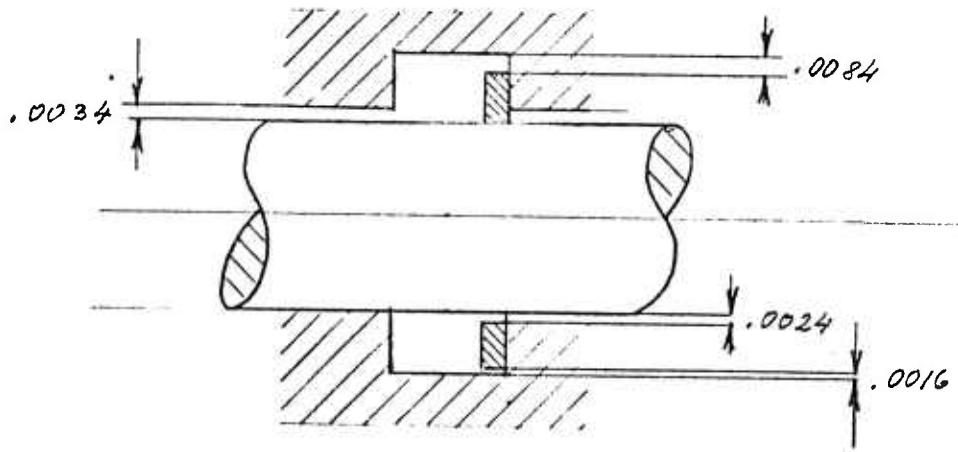

FIG. 3

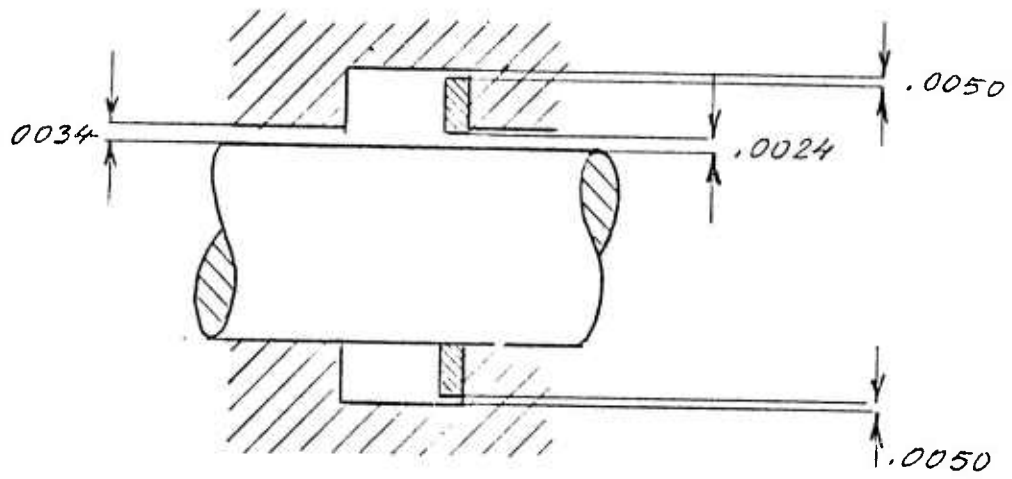

FIG. 4.

APPENDIX VIII

REPORT 03-258 Addendum III EVALUATION OF PARKER COMPOUND V747-75  
AT 450°F/4000 PSIG/USING CAST-IRON/REVENOC 18158 BACK-UPS - DEC. 3, 1973

1.0 INTRODUCTION: PURPOSE OF THE TEST

- 1.1 The purpose of this test was to check how long a seal assembly consisting of a V747-75 O-ring and a Revonoc 18158 back-up ring, supported by a cast-iron back-up ring could operate at temperatures reaching the maximum of 450°F with a simultaneous 4000 psi cycling pressure.

This test was a counterpart of the test performed at 450°F maximum test temperature on the piston seals using the same materials for the O-rings and for the back-up rings. The latter test was discussed in the Report No. 05-249 Addendum VII.

2.0 CONCLUSIONS AND RECOMMENDATIONS

- 2.1 Although both tests mentioned above had to be terminated before completion, because of the seal leakage, they supplied valuable information about the behaviour of the components of the tested seals at the operating temperatures reaching 450°F. The reaction of the seal components to external factors was basically of the same nature in both cases differing only in intensity. Thus some ground rules valid for both configurations could be established.

2.1.1 The permanent set of the V747-75 O-rings would be difficult to express in conventional terms. The O-rings were virtually remolded. Their cross section assumed the shape of capital D with the flat side towards the back-up rings and the semi-cylindrical shape towards the fluid. The remolding of the O-rings did not impair their sealing ability. However, surface erosion developed gradually at the corners of the "D" cross section adjacent to the gap between the moving parts. Ultimately such erosion impaired the O-ring's ability to seal causing leakage and termination of the test. It appeared that the O-rings with the least amount of squeeze were most susceptible to such type of failure.

2.1.2 The criterion which determined the operation of the plastic back-up rings tested (Revonoc 18158) was the width of the extrusion gap. A static extrusion gap .003 wide was found fully acceptable at 450°F and probably larger gaps could be tolerated. In case of clearances between the

moving parts the shearing forces acting upon the bearing surfaces of the plastic back-up rings prevailed and a gap as small as .002 could become critical. There were also some indications that at 450°F the shearing forces on the bearing surface of the Revonoc back-up ring might cause some cracks penetrating deeper into the material, the physical properties of which were degraded by temperature.

- 2.1.3 The cast-iron back-up ring behaved perfectly, showing zero wear when adequately centered. In cases of substantial lateral forces caused by uneven extrusion of the plastic back-up ring, the wear of the cast-iron ring was very small, not measurable by available instruments, and the bearing surface was smooth and shiny. The test fluid MIL-H-83282 showed symptoms of degradation.
- 2.1.4 The results of tests and their analysis indicated that a back-up system composed of a sacrificial back-up ring, of a selected plastic material, and of a supporting cast-iron ring, was superior to any back-up system which was tested or investigated by Parker Research & Development Department. In case of the piston seals, where the centering of the cast-iron may present a problem, the use of an intermediate metal ring between the plastic and the cast-iron back-up ring is recommended.
- 2.2 The following are the recommendations for the the next phase of development effort.
  - 2.2.1 Continue the research to find a type of plastic with the lowest rate of degradation of physical properties with temperature, with a low coefficient of friction and with a low rate of wear. The Teflon based materials with adequate fillers seem to be the most promising.
  - 2.2.2 Because the aforementioned double or triple ring back-up system seems of having reached the end of its development chain, systems based on different mechanical approach shall be investigated. There are indications that such systems could be developed.
  - 2.2.3 The increase of the maximum operational temperature shall be gradual. The full scale functional tests shall be preceded by investigation of the magnitude of degradation of the physical properties of the materials used for the seal components and by selection of the test fluid, which would not degrade during tests and impair the investigation of the test results by coating the test specimens with decomposed residuals.

3.0 BACKGROUND

3.1 Test Rig

Rod Seal Test Rig consisting of two assemblies to drawing 5718000 and provided with an improved heating system.

3.2 Components Tested

3.2.1 V747-75 2-214 dynamic O-rings and 2-218 static O-rings.

3.2.2 Revonoc 18158 back-up rings to ML-1294.  
Cast-iron back up rings to ML-1327.

3.2.3 Test Fluid per MIL-H-83282

3.3 Operational Conditions

3.3.1 Standard 1000 hours test. Fluid pressure 50 - 4000 psi.

3.3.2 Temperature Range: -40°F to 450°F

3.4 Occurances During the Test

3.4.1 The test proceeded smoothly. No leakage occurred at -40°F. Small leakages were noticed during the warming up operations but stopped before the temperature reached 450°F (See Appendix 1).

3.4.2 After approximately 73,400 pressure cycles a large leak appeared at the drive side seal of the Pod #2. The test was stopped and the pods were disassembled for inspection.

4.0 DISCUSSION OF THE TEST RESULTS

4.1 Figure 1 shows a schematic layout of the seal components. The diameters specified here were measured on the components to be tested. The close fits between the cast-iron back-up ring and the adjoining components were most likely responsible for good conditions and for maintenance of shape of the Revonoc back-up rings.

Every Revonoc back-up ring inspected showed a short (.010 approximately) extrusion lip at its outer circumference. It fit the .003 gap between the fixture body and the cast-iron ring. The uniform width of this lip indicated that both rods were close to their theoretical central position during the operation of the rig. Because of a very close fit between the cast-iron back-up rings and the rods, very few fringes appeared at the inner circumferences of the Revonoc back-up rings. However, on some back-up rings fringes were found as well on the

outboard as on the inboard edges of the inner ring's circumferences. The formation of the inboard fringes was never noticed before during the inspection of seals tested at 350°F or below this temperature. This phenomenon might be attributed to the following fact: In the absence of a strong extrusion tendency into the very narrow gap (.0005 approximately) between the rod and the cast-iron ring, the outer layers of the Revonoc bearing surfaces, softened by high temperature, might be highly susceptible to the drag of the rod while it moved forth and back.

In general the bearing surfaces of the Revonoc rings bores appeared smooth, with the exception of a local shallow depression on the surface of the ring at the drive side of the Rod No. 2. This depression might be in some way responsible for the leakage which occurred at this seal and which was the cause of termination of the test.

- 4.2 The cast-iron back-up rings showed almost no wear, thanks to their central position and to the absence of significant lateral forces.
- 4.3 The V747-75 O-rings were remolded, their cross section assuming the capital D shape. (See also Paragraph 3.4 of the Report 05-249, Addendum VII) Some local erosion and material deterioration was found at the inner corners of the D shaped O-rings. Such erosion was caused most likely by rubbing of the O-rings against the inwardly formed fringes of the Revonoc rings. The deepest erosion was formed on the O-ring on the drive side of the Pod No. 2, where the leakage developed.
- 4.4 A similar case of O-ring cross section remolding into a D shape and of the erosion at the inner D corner was found in case of the static 2-218 V747-75 O-rings.
- 4.5 The components of the seals were covered with a brownish coat of the degraded test fluid.



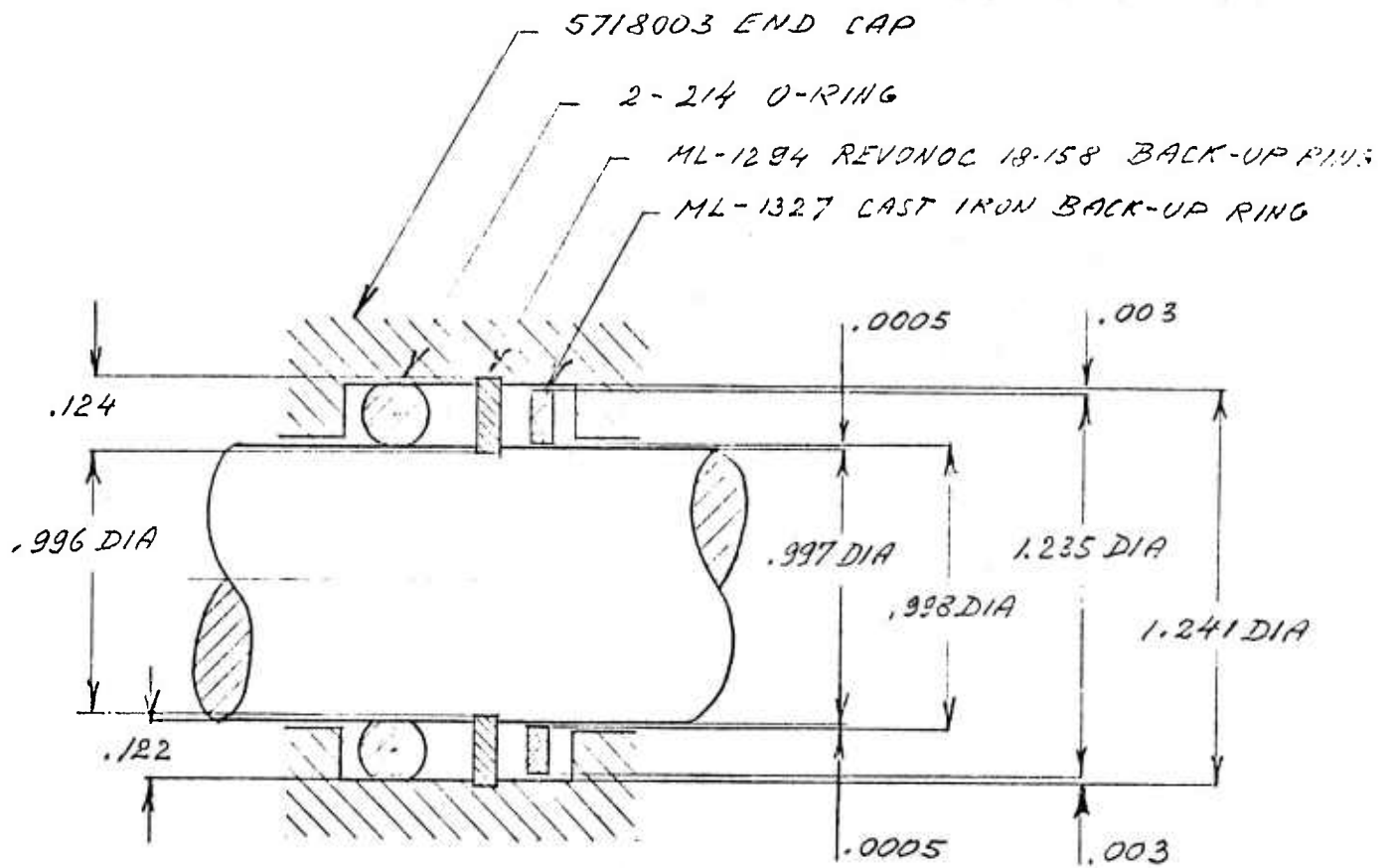

FIG. 1.

# Parker SEAL COMPANY

CULVER CITY, CALIFORNIA

APPENDIX IX

REPORT: 05-249

REV: \_\_\_\_\_

PAGE: \_\_\_\_\_

REPORT 05-249 Addendum III EVALUATION OF MIL-P-25732B COMPOUND N304-7  
AND SHORT TERM EVALUATIONS OF AFE-XV1836-2, AFE-XV1836-7, AFE-XV1836-10,  
AFE-XV1836-11, and VS-35 - JUNE 15, 1973,

## 1.0 BACKGROUND

1.1 The tests commented on in this report were the continuation of the piston seal development tests described in the Report No. 05-249 and in the Report No. 05-249 Addendum I and Addendum II.

The tests included a full length test (99036 cycles) performed with the N304-70 dynamic O-rings (see Appendix I) and six screening tests (approximately 16,000 cycles each) performed with the dynamic O-rings made of the XV1836-2, XV1836-10, XV1836-11, VS-35, XV1836-7 and XV1836-2 compounds. The tests were run with every second cycle under 3000 psi pressure followed by a cycle under the pressure reduced to 50 psi approximately (see test data sheets Appendix I).

The performance of the tested O-ring compounds and their respective merits are commented elsewhere. This report is limited to the study of the behaviour of the back-up rings, their geometry, their wear and their conditions after completion of the tests. It also attempts to determine the amount of protection which the above back-up rings offer the dynamic O-rings.

## 2.0 DISCUSSION OF THE TEST RESULTS

The basic data on the tested back-up rings are specified in Table 1 through Table 5. The conditions of the back-up rings and of the dynamic O-rings inspected after tests are described in the above Tables under "Remarks."

The full length test with the N304-70 O-rings were performed with Tetralon 720 back-up rings to ML-1235, ML-1236 and ML-1237. (The same rings as used in the test Report No. 05-249 Appendix I). The O.D. of these back-up rings was 1.253-1.255, which resulted in an interference fit of .011 to .013 with the cylinder bore.

The initial squeeze of these back-up rings in the grooves was .003-.005.

The 1.253-1.255 O.D. of these back-up rings was retained in order to conform with the tolerances of the standard MS27595-214 back-up ring. However, the large interference fits of those rings with the cylinder bore had no technical justification.

The back-up rings to be used with the O-ring screening tests were therefore modified to drawings ML-1271, ML-1272 and ML-1273. Their O.D. was reduced to 1.245-1.247, thus reducing the interference fit with the cylinder bore to .003-.005. The I.D.'s were corrected to obtain a .0025-.0045 squeeze in the groove. Such a squeeze was considered beneficial for the initial breaking-in of the back-up rings.

The Tetralon 720 back-up rings used in conjunction with the N304-7 O-rings were subjected to 99036 operational cycles (see Table 1).

The Revonoc 18158 back-up rings specified in Table 2 mounted with XV1836-11 O-rings and the Revonoc 18158 back-up rings specified in Table 3 and mounted with VS-35 O-rings were all subjected to 16000 operational cycles approximately.

In all back-up rings inspected after tests a small extrusion lip was found at the O.D. at the face opposite to the face contacting the O-ring. The length of the extrusion lip did not exceed .005.

In the case of some back-up rings, the thickness of the extrusion lip was uniform around the ring circumference indicating a central position of the piston in the cylinder. In the prevailing cases, however, the extrusion lip was wider on a part of the circumference, degenerating to some fringes, or in a few cases almost disappearing on the opposite side of the circumference. The width of the extrusion lip did not exceed .004-.005 at any place.

Table 2 in the Report 05-249 indicated that the diametral clearance between the pistons and the cylinders of the Fixture #2 were found to be .007. Thus the extrusion gap could vary theoretically from 0 to .007, practically from some .002 to .005, in agreement with the measured thickness of the extrusion lip.

The back-up rings specified in Table 4 were used twice. For the first time they were mounted with the XV1836-10 O-rings (test starting 4-30-73) accomplishing 15600 operational cycles. For the second time they were mounted in a reversed position with the XV1836-7 O-rings (test starting 5-14-73) completing 15718 operational cycles (see the test data sheets Appendix 1).

The back-up rings specified in Table 5 were also used twice. The first time they were mounted with the XV1836-2 O-rings (test starting 4-24-73) accomplishing 15600 operational cycles. Then they were mounted in the reversed position for the second test with the XV1836-2 O-rings (test starting 5-24-73) completing 15600 operational cycles.

In the back-up rings, Table 4 and Table 5, the extrusion lips were noticeable at both faces of each ring. The larger ones, formed during the first breaking-in of the back-up ring were well delineated while the lips at the opposite face were much fainter, disappearing really.

The virtually unchanged and undistorted shape of the back-up rings after completion of tests indicated that no flow of material occurred within the ring body. The lips were formed from the excess of the material (.0025-.0045 per groove depth) provided in the design for the initial breaking-in of the ring.

The flow of the material at the outermost circumference of the back-up rings occurred when the ring was dragged by the cylinder wall against the gap under 3000 psi pressure, transmitted to the back-up ring through the O-ring. Due to its resiliency and high cohesion the material sacrificed for the initial breaking-in of the back-up ring remained attached to the ring body in the form of a lip extending into the gap between the piston and the cylinder bore. The lip had a beneficial effect of stabilizing the piston in the cylinder bore with a minimum clearance.

No tests were performed to determine the rate of formation of the extrusion lips. It appears, however, from the analysis of data accumulated in Table 1 throughout Table 5 that the lips would be formed in the early stages of the back-up ring breaking-in. Once the high bearing pressure caused by the back-up ring squeeze in the groove was relieved by the lip formation and the piston was stabilized, the rate of wear of the back-up rings should be very small.

Two facts shall be noticed in favour of the existing back-up rings.

1. The surface of contact of the back-up ring with the cylinder bore remained very smooth with no scratches nor flow lines of the material.
2. In spite of the fact that the lips formed during the first test of the back-up ring protruded against the O-rings when the back-up rings were mounted in the reversed position for the second tests, no injuries of the O-rings could be detected.

### 3.0 CONCLUSION

- 3.1 The Tetralon 720 back-up rings completed 99036 operational cycles during a full length dynamic material evolution test, while the Revonoc 18159 back-up rings were subjected to 31200 and 15600 operational cycles maximum during the abbreviated O-ring material screening tests.

A 275°F operational temperature and at 3000 psi maximum pressure differential, both types of back-up ring material performed very well. Under the test conditions specified above no superiority of one of these materials above another could be detected.

The surface at the back-up ring's outer circumference which slip against the cylinder bore was in all cases very clean and smooth, without scratches nor wear marks.

Both types of the back-up rings provided full protection for the O-rings. No evidence of O-ring extrusion nor erosion or injury to the O-ring surface was noticed.

- 3.2 In all back-up rings retrieved after test, a small extrusion lip was noticeable at the O.D. of the ring side opposite to the O-ring side. The lips were formed of the excess of material (.0025-.0045 over the gland depth) provided on each back-up ring for the initial breaking-in.

The purpose of the above .0025-.0045 interference fit of the back-up ring in the gland was:

- 3.2.1 Prevention of the formation of a gap between the back-up ring I.D. and the bottom of the piston groove. Such a gap would be harmful functionally (see Report No. 05-249).
- 3.2.2 Assurance of a permanent establishment of the zero gap between the back-up ring O.D. and the cylinder bore even in the case where the piston would assume a slight off-center operational position in the cylinder bore. Such an off-center position is usually the result of the coincidence of the diametral end of the off-center manufacturing tolerances, of assembly fits and of wear. It is anticipated and it is acceptable within the tolerances established for each class and type of the component.

While a certain degree of the piston off-center position can not be avoided, it can be made harmless by providing an excess material for the back-up ring breaking-in process as described above.

- 3.3 The interference and clearance figures recorded on the back-up rings at the after-test inspection (see Table 1 throughout Table 5) and also the fact that no traces of erosion nor injury were found on the tested O-rings at the locations where they were wedged against the back-up ring gaps, seem to prove that the means adopted to achieve a successful breaking-in of the back-up rings were correct.

- 3.4 Because the tests described in this report were performed to select the most suitable compound for the O-rings and were programmed accordingly, it was not possible to follow up experimentally the progress of breaking-in of the back-up rings. However, the data collected at the after-test inspection of the back-up rings seem to indicate that after the stresses caused by the squeeze of the back-up rings were relieved through the local motion of the material and formation of the extrusion lips, the operation of the piston would be stabilized and the wear of the back-up rings would be slow.
- 3.5 To be acceptable for standardization the back-up ring must be suitable as well for the operation with a piston seal as with a rod seal. Thus the suitability of the ML1272 back-up ring for the operations with the latter will be now investigated.
- 3.6 It appears that enough tests were performed already to permit selection of the most suitable squeeze of the O-ring. This selection would permit reduction of the three back-up rings alternatives used now in each piston cylinder seal test to one. The selection of the most suitable O-ring squeeze would not require any follow-up in the back-up ring design. All three back-up ring alternatives were mounted in their respective glands with the same fits.

1000 HRS TEST AT 275°F TEST STARTED 6.4.73 ENDED 7.17.73 119200 CYCLES.

	CYLINDER #1 BACK-UP RING ML-1271 REVUNOC 18158		CYLINDER #2 BACK-UP RING MIL-R SPEC REVUNOC 18158		CYLINDER #3 BACK-UP RING ML-1273 REVUNOC 18158	
	FRONT	REAR	FRONT	REAR	FRONT	REAR
CYL. BORE DIA [MEASURED]	1.242	1.242	1.242	1.242	1.242	1.242
BACK-UP RING O.D. DIA	1.246 ± .001	1.246 ± .001	1.246 ± .001	1.246 ± .001	1.246 ± .001	1.246 ± .001
BEFORE TEST [DESIGN]	1.253	1.253	1.251	1.251	1.253	1.253
" " [MEASURED]	.129	.129	.123	.123	.117	.117
GLAND DEPTH [MEASURED]						
WIDTH OF THE BACK-UP RING:						
NEW RING [DESIGN]	.135 - .1335	.135 - .1335	.118 - .120	.118 - .120	.1195 - .1215	.1195 - .1215
" [MEASURED]	.135	.135	.120	.120	.122	.122
AFTER TEST [MEASURED]	.125 - .129	.119 - .129	.121 - .123	.120 - .121	.112 - .117	.115 - .117
GLAND - BACK-UP RING FIT	.002 - .004 INTER.	.002 - .004 INTER.	.003 CLEAR	.003 CLEAR	.005 INTER.	.005 INTER.
AT ASSEMBLY	.004 - .000 CLEAR	.010 - .000 CLEAR	.002 - .000 CLEAR	.002 - .003 CLEAR	.005 - .000 CLEAR	.002 - .000 CLEAR
AFTER TEST						
REMARKS:						
BACK-UP RING	THIN, SHORT FRINGS AT O.D. QUINARDLY DIKED, DWAPPER-RING LOCALLY	THIN, FAIRLY LONG FRINGS AT O.D. OUTWARDLY DIKED, OTHERWISE O.K.	FRINGS, LOCALLY WIDENING TO EXTRUSION LIPS, OTHERWISE O.K.	THIN, FAIRLY LONG FRINGS PARTI-CULARLY AT THE WARTONWEST PART OF THE RING	EXTRUSION UP AT THE MARKS - WEST PART OF THE RING, DIS-APPEARING AT OPPOSITE SIDE	FAIRLY LONG IRREGULAR FRINGE OVER THE WHOLE CIRCUMFER-RENCE
O-RING	SL. FLAT AT O.D. SHALLOW FURROW AT DOWNSTREAM CORNER, SPLIT IN THE PLANE OF SYMMETRY WITHIN .50 DIA INTERFERENCE	SLIGHTLY FLAT. TENED AT O.D. SHALLOW MARKS AT DOWNSTREAM O.D. OTHER CORNER AT 1/4 OF CIRCUM.	SLIGHTLY FLAT. TENED AT O.D. ALMOST NO EX-TENSION AT THE DOWNSTREAM O.D. CORNER	SLIGHTLY FLAT- TENED AT O.D. LIGHT LOCAL ERSION AT THE O.D. CORNER	SPLIT IN TWO PLACES IN THE PLANE OF SYM-METRY ALONG 1/2" ± 1/2" OF CIRCUMFEREN-CE	FLATTENED AT O.D. & DOWNSTREAM WALL. NO EROSION
2-214 XN 1925-33						
ALL O-RINGS SOFT PLIABLE						
WIPER O-RING						
2-218 XN 1925-33						

ALL WIPERS HARD & BRITTLE. BREAK WHEN DEFORMED

TAB. I.

APPENDIX XI REPORT 05-249 Addendum V. EVALUATION OF PARKER  
 COMPOUND V747-75 IN MIL-H-83282 FLUID 350°F, 4000 PSIG USING CAST-IRON/REVENOC  
 18158 BACK-UPS

1.0 INTRODUCTION

SEPT. 27, 1973

1.1 The subject of this report is a functional analysis of the O-ring back-up system consisting of two back-up rings, a plastic one and a metal one mounted in tandem. The study was undertaken in order to determine the causes of the failure of the plastic back-up ring mounted in the cylinder #1 of the test rig #2. The failure occurred after 62,400 operational cycles during the 1000 hour material evaluation test performed under the Air Force Materials Laboratory Contract No. F33615-71-C-1304.

2.0 BACKGROUND

2.1 The test, which started on August 7, 1973 and is still in progress was performed under the following conditions:

2.1.1 Components tested

2.1.1.1 2-214 O-rings of the V747-75 compound.

2.1.1.2 The following components of the back-up system:

	Cylinder #1 Low Squeeze	Cylinder #2 Med. Squeeze	Cylinder #3 High Squeeze
Retainer	ML-1202	ML-1203	ML-1204
Revonoc 18158 back-up	ML-1295	ML-1294	ML-1296
Cast-iron back-up	ML-1299	ML-1293	ML-1300

2.1.1.3 2-218 O-rings of the V747-75 compound installed as wipers.

2.1.2 Test Fluid per MIL-H-83282

2.1.3 Test Conditions

2.1.3.1 Fluid pressure range: 50 to 4000 psi.

2.1.3.2 Temperature range: -30°F to 350°F. The target low temperature of -65°F could not be reached because of excessive fluid leakage. The lowest test temperature at which the fluid leakage was found to be acceptable was -30°F in the first phase of the test. After two series of 15,000 cycles, the low temperature static leakage was found to be again too high. The low test temperature was therefore increased to -20°F for the balance of tests.



2.1.4 Test Procedure

2.1.4.1 The data recorded during the tests already performed are contained in the appended Test Data Sheets.

The test was stopped temporarily at the end of the fifth static pressure check because of the sudden outburst of leakage at the front end of the Cylinder #1. This cylinder was dismantled for inspection. The results of inspection of the O-rings and the back-up rings from this cylinder are given in Par. 3.0. The test is continuing with the Cylinders #2 and #3 only.

3.0 REPORT ON THE INSPECTION OF THE COMPONENTS OF THE PISTON ASSEMBLY OF THE CYLINDER #1

3.1 Front End (Opposite to the Drive)

3.1.1 Cast-Iron Back-up Ring ML-1299

Dimensions after test: O.D. = 1.238-1.239. W. = .117-.118. The cast-iron back-up ring showed wear (approximately .0010 to .0015 deep) along less than one-third of its outer circumference. The remaining circumference was covered with a fairly thick (.004 mm) coat of material extruded from the Revonoc back-up ring. Some of this extruded material was smeared over the surface of the sleeve ML-1205 outwardly of the cast-iron ring.

3.1.2 The Revonoc 18158 Back-up Ring ML-1299

The picture of the Revonoc Back-up Ring is shown on Figure 1. This figure and the sketch, Figure 2, show a substantial extrusion of the back-up ring material. From the back-up ring cross section adjacent to the worn stretch of the cast-iron back-up ring most of the material disappeared. Some of this material was extruded into the gap between the cast-iron ring and the bottom of the groove machined in the Retainer. At the opposite half of the Revonoc back-up ring most of the material was extruded into the gap between the cylinder bore and the cast-iron outer circumference.

3.1.3 The V-747-75 O-ring

A chunk of the O-ring material was missing at the location adjacent to the missing section of the Revonoc back-up ring. No other damage was noticeable on the O-ring. The ring was pliable and no permanent set could be detected.

3.2 Rear End (Drive Side)

3.2.1 Cast-Iron Back-up Ring ML-1299

Dimensions after test: O.D. = 1.239-1.2395. W. = .117-.119. The cast-iron back-up ring showed wear (approximately .001 deep) along one-fourth of its outer circumference. The worn portion of the rear cast-iron ring was situated approximately at the same side of the piston as the worn section of the front cast-iron ring (rotated about 10° anticlockwise).

3.2.2 The Revonoc Back-up Ring ML-1299

The cross section of the Revonoc back-up ring traced in the plane bisecting the worn portion of the cast-iron ring is shown on Figure 3. The location and the thickness of the extrusion lips indicate that the cast-iron ring was in an off-center position with respect to the center line of the retainer when the extrusion took place.

3.2.3 The V-747-75 O-Ring

The O-ring was intact.

4.0 DISCUSSION OF THE FAILURE OF THE BACK-UP SYSTEM

4.1 Figure 4 shows schematically a cross section of the piston seal back-up system including the Cylinder ML-1199, the Piston ML-1201, the Sleeve ML-1205, the Retainer ML-1202, and the metal Back-up Ring ML-1299. The O-ring and the plastic Back-up ring were omitted for simplicity's sake. The maximum and minimum limits on the diameters of the above components (as specified on the pertinent drawings) are shown here. Figure 7 shows the same cross section, but with dimensions as measured on the tested components prior to the test.

Figure 5 and Figure 8 specify the gaps which would exist between the adjacent surfaces of the above components if these components were held in a strictly concentric position.

The maximum possible off-center position of the assembly ML-1201, ML-1205 and ML-1202 with respect to the cylinder bore is shown by the dimensions next to the arrow "A" in Figure 5 (.0035-.0075) and in Figure 8 (.0015). It was assumed here that the piston components ML-1201, ML-1205 and ML-1202 were assembled in a strictly concentric position. If these components were, however, assembled and locked in a most adverse off-center position as shown on Figure 6 and Figure 9, the retainer ML-1202 would be held in a more extreme off-center position as shown by the dimensions in brackets next to the arrow "A" (.0035-.0075) in Figure 5 and (.0035) in Figure 9.

The above off-center positions were determined from the clearance fits between the adjoining components as specified in Figure 5 and Figure 8. The maximum possible off-center position of the floating back-up ring ML-1299 is shown by the figures next to the arrow "B" in Figure 5 and Figure 8. Figure 6 and Figure 9 show the widths of the gaps between the adjacent surfaces of the above components with the components moved in the opposite directions to their maximum off-center positions.

The width of the gap between the bottom of the ML-1202 retainer's groove and the metal back-up ring ML-1299 is indicated in Figure 6 by three pairs of dimensions. If the piston components ML-1201, ML-1205 and ML-1202 were assembled and secured in a strictly concentric position, the width of the gap would be indicated by the figures at 2) (.0100-.0145 and .0035-.0050). If the above improvements were assembled off-center as shown on Figure 6 the figures at 1) would apply. If the above components were assembled and secured in an off-center position reversed to that on Figure 6 the figures at 3) would be valid.

A similar situation as that shown on Figure 6 exists in the case of Figure 9. The width of the gap between the piston and the metal back-up ring re: 1), 2) and 3) was calculated here from the dimensions of the components tested.

For practical purposes the off-center assembly of the piston components might be neglected and the figures re: 2) should be assumed as representing the most likely to occur, width of the gap in the maximum off-center position of the piston and the metal back-up ring.

In the Fixture #2 the pistons are not subjected to lateral forces. Nevertheless, they would most likely assume some off-center positions within their clearance fits because of their weights. Since the metal back-up rings are guided by the cylinder bores, the widths of the gaps between the back-up rings inner

circumferences and the bottoms of the piston grooves may vary. The gaps would be widest at the upper sides of the pistons and narrowest at the bottoms.

If the material of the plastic back-up ring behaved as a perfect viscous fluid and filled the extrusion gaps fully notwithstanding of their widths no unbalanced lateral forces would exist in the system. However, in case of a typical plastic the lip is extruded against the material's resistance to deformation and against the external friction forces. The internal compression stress which causes extrusion would fade along the advancing lip.

The extrusion would start at the location where the gap was the widest. The forces tending to widen the gap would depend on the length and on the width of the extrusion lip.

Thus the extrusion forces would push the piston and the floating metal back-up rings into oppositely oriented off-center positions and press them against the cylinder wall. (See Figure 6 and Figure 9)

The dimensions and configuration of the extrusion lips of the plastic back-up ring retrieved after tests confirm that the above conditions existed during the rig operation. (See Figure 2 and Figure 3 showing the cross sections through the extruded plastic back-up rings.)

The lateral shift of the metal back-up rings enlarged also the gaps between the rings' outer circumferences and the cylinder wall at the locations "T" Figure 2 and Figure 3, and opened the way to extrusion of the plastic rings' material at these locations.

The extrusion was facilitated here by the dragging action of the cylinder wall in motion. Thus a certain amount of the plastic back-up rings' material escaped through these gaps and was smeared over the surfaces of the adjacent sleeves. (See Par. 3.1.1)

The magnitude of the lateral forces tending to shift the piston and the metal back-up ring into opposite directions cannot be easily evaluated. The .001 to .0015 wear along 1/4 to 1/3 of the metal back-up ring outer circumference at the location of the maximum lateral shift seems to indicate that this force may be significant.

The back-up ring system consisting of a plastic back-up ring and a metal one was designed with a consent that a certain amount of extrusion of the former will take place. It was assumed

however that the volume of the extruded material would be too small to cause an unacceptable reduction or deformation of the plastic back-up ring's cross section. The extrusion was to take place mainly into the blind gap between the floating metal back-up ring and the bottom of its groove. To fill such a gap completely the following amount of material had to be transferred from the adjacent cross section of the plastic ring.

Width of the Gap	% of the volume of the back-up ring material transferred (within the pertinent cross sections)
.009	6.6%
.011	8.1%
.013	9.6%

The after-test inspection of the present Revonoc back-up ring (Figure 3) seems to indicate that the above assumption was in general correct. The cross section of this ring was little affected by the extrusion. The O-ring did not show any signs of extrusion nor injury and the seal as a whole remained functional.

There is however no satisfactory explanation for the deep erosion of the front end Revonoc back-up ring (Figure 1 and Figure 2) and for the disappearance of the almost entire cross section of this ring along a 0.3 long portion of the ring circumference.

## 5.0 CONCLUSIONS AND RECOMMENDATIONS

- 5.1 The use of a plastic-cum-metal back-up ring system was proposed for operation at temperatures and pressures at which the single back-up rings made of the best temperature resistance plastics would fail because of extrusion. It should be kept in mind, however, that the only improvement which would be obtained through the use of the metal back-up ring was the possibility of reduction of the gap between the working surfaces. This reduction of gap would not be significant, because a certain minimum gap had to be maintained between the moving surfaces, to prevent their seizing. The manufacturing tolerances and the wear would add to the gap. A more significant advantage appeared to be the possibility of maintaining this gap uniform along the working back-up ring circumference even if the center

lines of the mating components (piston and cylinder bore, or rod and bushing) did not coincide. This could be achieved by mounting the metal back-up ring floatingly in its groove.

The floating movement of the back-up ring was obtained however at the cost of creation of a larger gap between the back-up ring and the bottom of its groove. This gap was considered harmless as it was blind, and closed at its end by the wall of the groove, thus limiting the volume of the plastic back-up ring's material which could be extruded. The distortion of this back-up ring could be minimized by making it bulky enough.

The test of the above system emphasized, however, the importance of another, hitherto not sufficiently appreciated factor connected with the stress pattern in the extrusion lip of a plastic material. If a plastic material is extruded into a gap of uneven width, the extrusion will start at the location where the gap is the widest and will produce there the longest and the thickest lip. The extrusion occurs when the compression stress in the material being extruded exceeds the material's resistance to deformation and the friction forces opposing the creep of the extrusion lip. The said compression stress produces also the forces tending to expand the gap. The magnitude of these forces depends among other factors on the length and on the thickness of the lip.

Thus in the system described above, an unbalanced lateral force could be created. Such a force would tend to push the metal back-up ring off center in the direction opposite to the off-center position of the piston. The existence of such a force was evidenced by a roughly .001 deep wear along 1/4 to 1/3 of the outer circumference of the tested back-up rings exactly at the location which could be predicted from the pattern of extrusion lips.

Provided that the failure of the front and plastic back-up ring was accidental, the wear of the metal back-up rings would be the criterion, which would determine the span of the useful life of the back-up system. Considering the severity of the test, this wear does not seem to be excessive. Also the ways of reducing it might be found. More experimental evidence would be necessary to determine the suitability and the potentiality of the above system. It is expected that the examination of the seal components of the Cylinder #2 and #3 after completion of tests would supply some of such evidence.

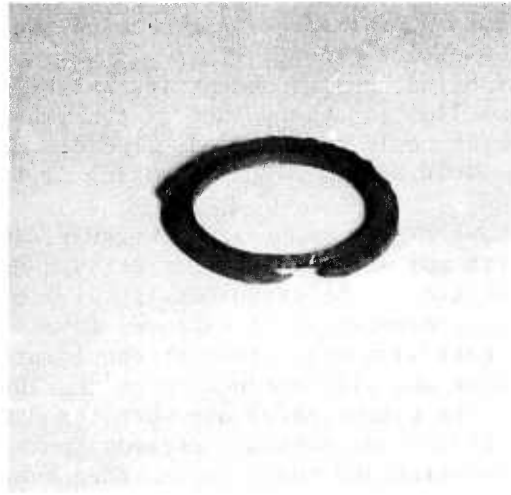

FIG. 1.

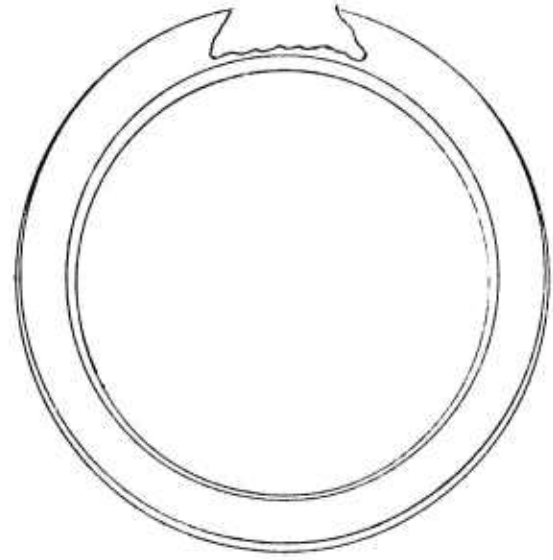
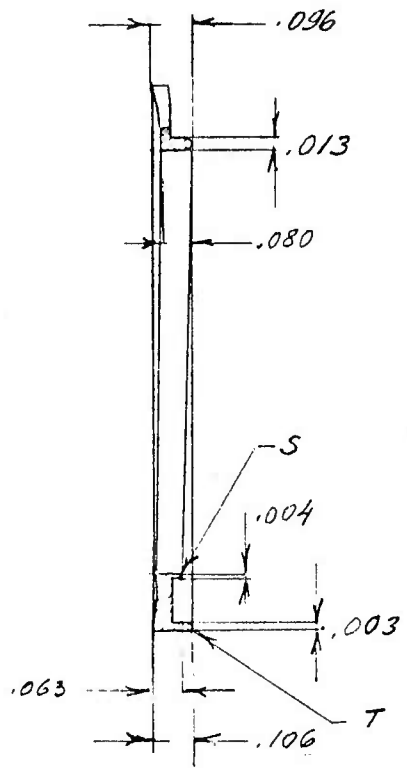

FIG. 2.

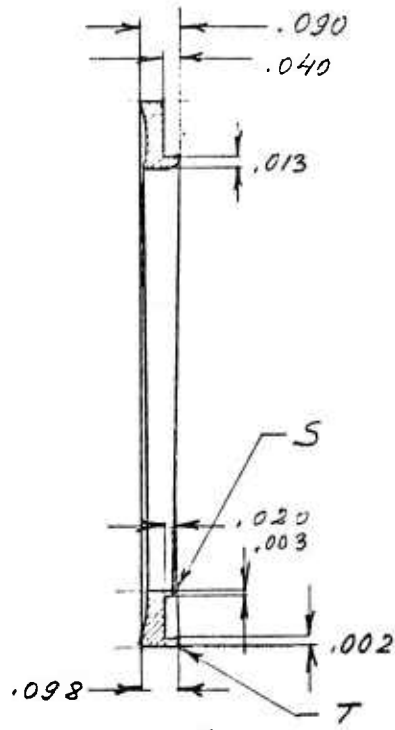

FIG. 3.



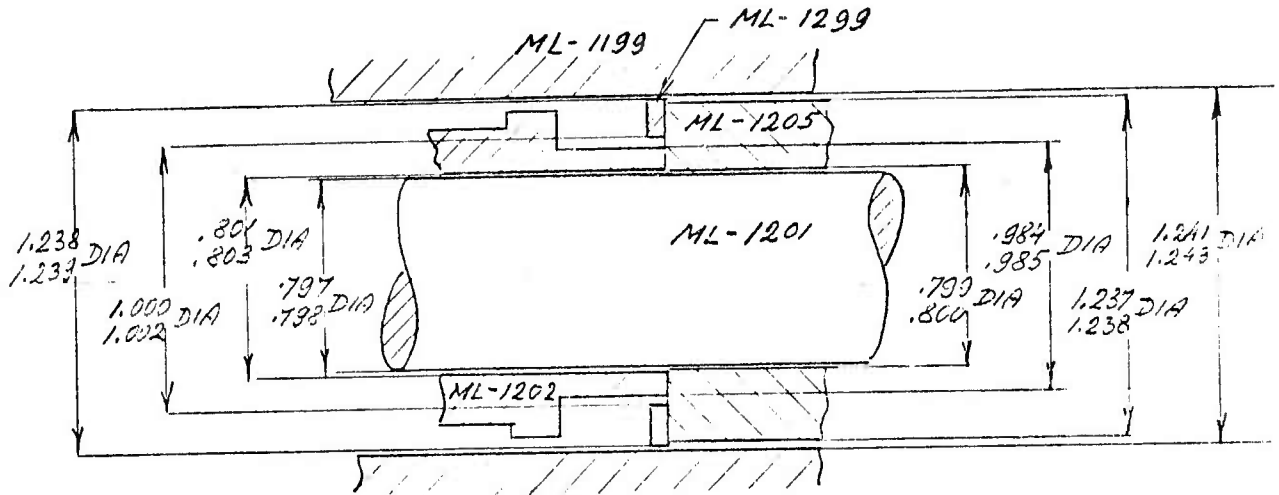

FIG. 4.

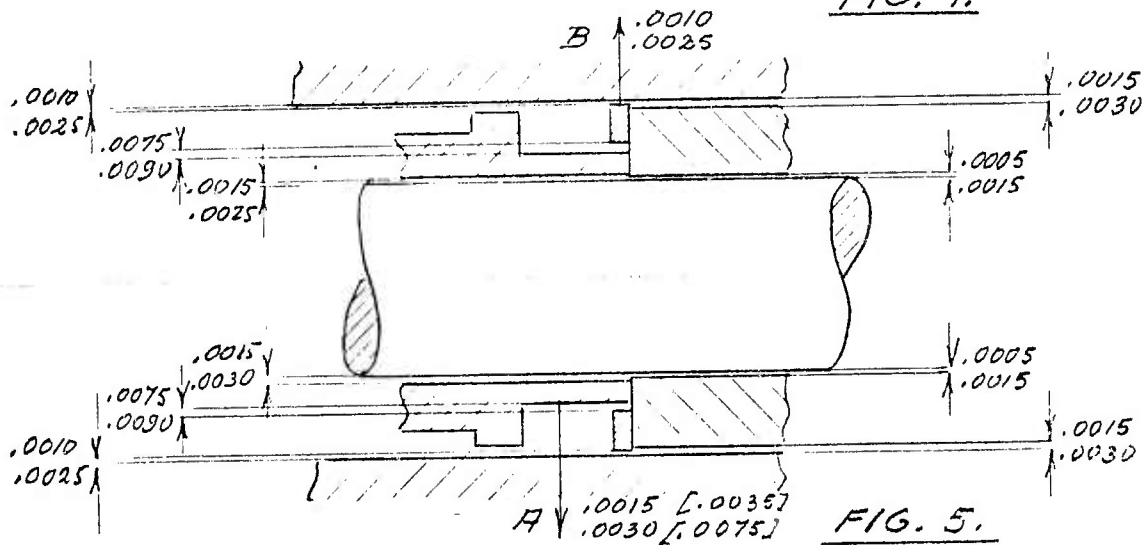

FIG. 5.

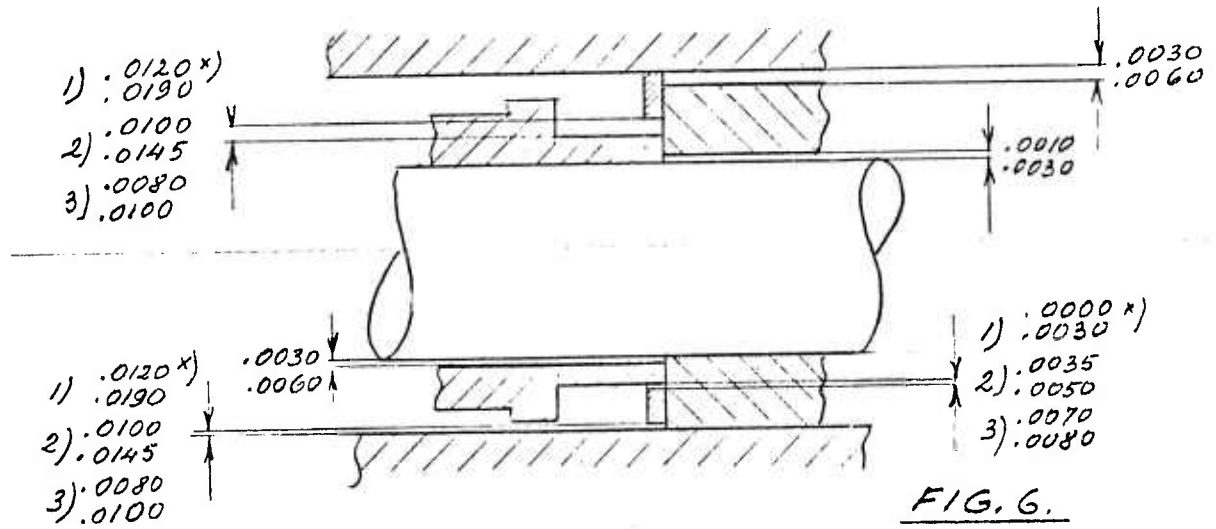

FIG. 6.

x) AS SHOWN

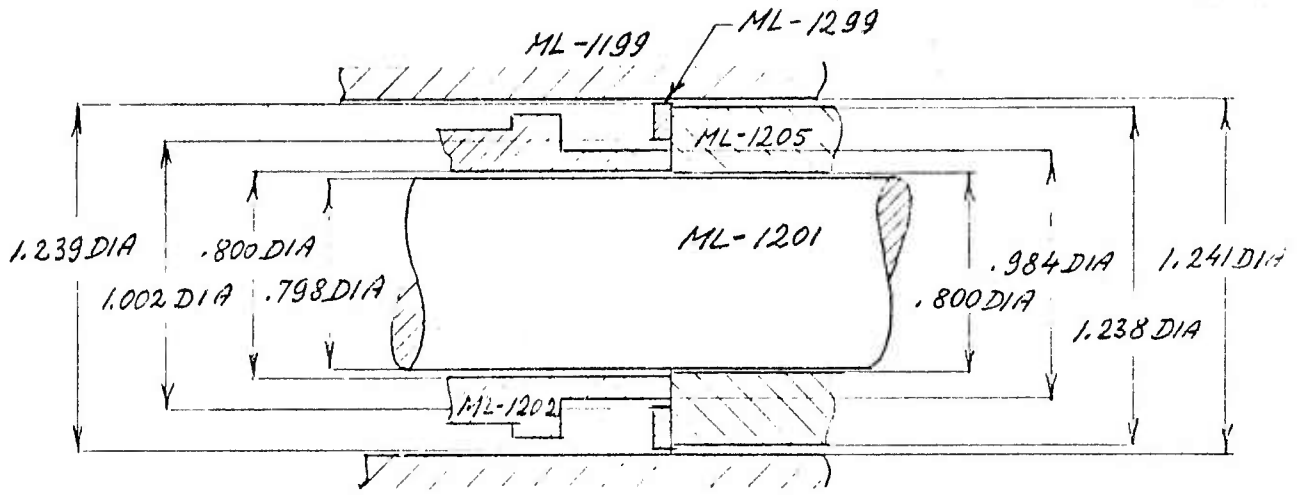

FIG. 7.

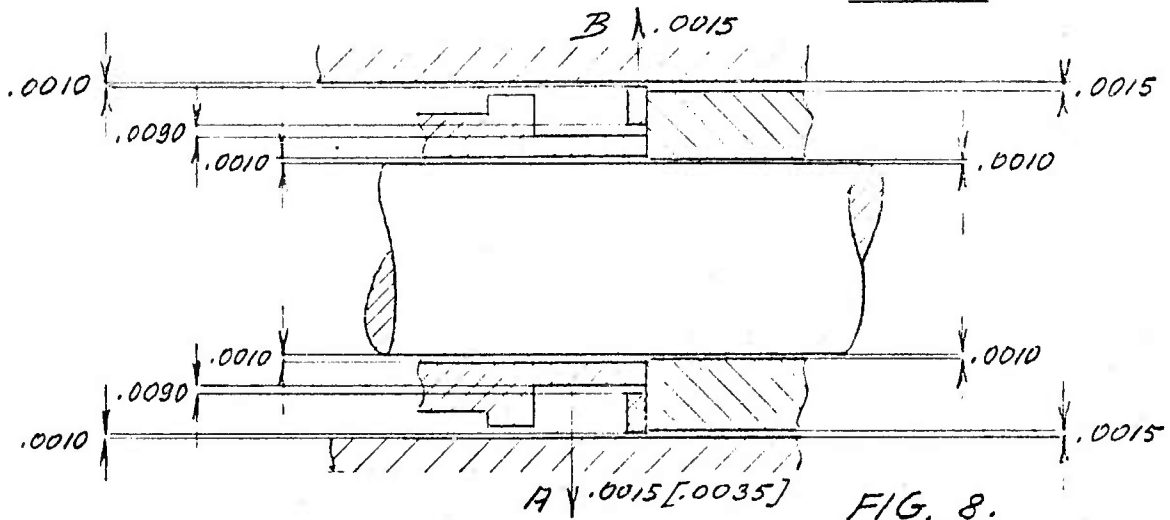

FIG. 8.

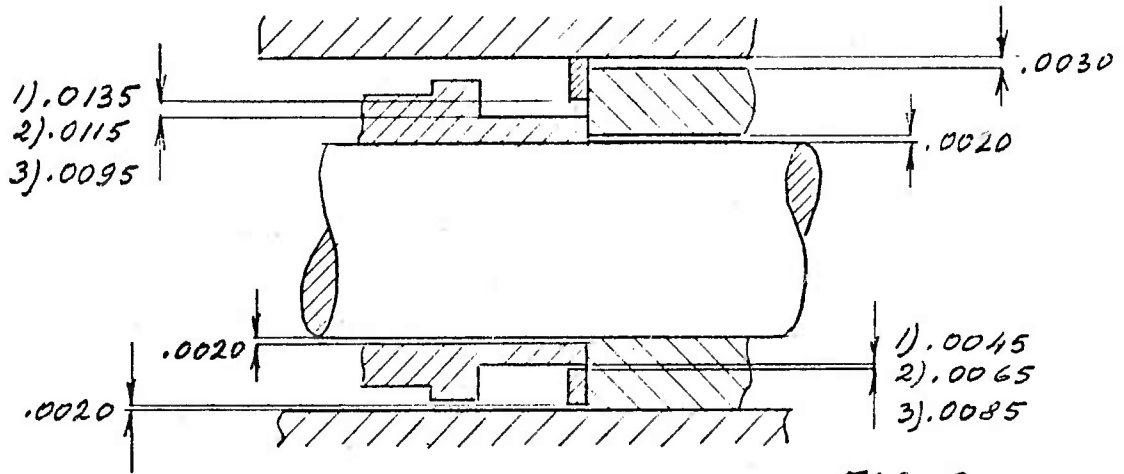

FIG. 9.

# Parker SEAL COMPANY

CULVER CITY, CALIFORNIA

REPORT: 05-249 REV: \_\_\_\_\_  
PAGE: \_\_\_\_\_

REPORT 05-249 ADDENDUM VI. EVALUATION OF PARKER COMPOUND V747-75 IN MIL-83282  
350°F, 4000 PSIG USING CAST-IRON/REVENOC 18158 BACK-UPS NOV. 2, 1973

## 1.0 BACKGROUND

This report is a supplement to the Report No. 05-249 Addendum V. It was written after completion of the 1000 hours test with the cylinders #2 and #3 operating. The test was completed successfully with practically no fluid leakage recorded. (See Appendix 2.) The report on the conditions of the tested specimens inspected after completion of the test is contained in the Appendix 1.

## 2.0 COMMENTS AND RECOMMENDATIONS

The after-test inspection of the seal assemblies on the pistons #2 and #3 fully confirmed the phenomenon of the lateral shift of the metal back-up rings. This shift, which was discussed and explained in the Addendum V was the direct cause of the localized wear of the cast-iron back-up rings. By intensifying extrusion it was also the cause of weakening of the plastic back-up rings. This weakening could, and in the case of the Cylinder #1 probably did, cause the failure of the plastic back-up rings.

When estimating the wear of the piston components, which in the case of the cast iron back-up rings was minimal, and in the case of the plastic back-up rings was acceptable, the severity of the 1000 hours test should be considered. The 134000 operational cycles were performed at 4000 psi and most of the time at 350°F thus under conditions which would only sporadically occur in service. Therefore, the 1000 hours test may be comparable to several months or maybe years of operation under service conditions. On the other hand the test was performed in a rig designed with clearances close to the optimal and with negligible lateral forces. Large tolerances on the cylinder and piston components, and wear of these components, which to a certain extent must be tolerated in service, might increase the lateral shift of the cast-iron back-up ring, with its undesirable consequences. It is therefore recommended that steps be taken to eliminate or at least to reduce the lateral shift of the metal back-up ring.

The proposed solution is shown on Figure 1 and Figure 2. A thin (.016 inch) intermediate metal ring is mounted between the cast-iron and the plastic back-up ring. Fitted with a close clearance with the bottom of the piston groove, the intermediate ring will move with the piston but will never contact the cylinder bore. It would not handicap the flotation of the cast-iron ring. But reducing the plastic ring extrusion into the gap between the cast-iron ring I.D. and the bottom of the groove it should eliminate or at least reduce the imbalanced force causing the lateral shift of the cast-iron back-up ring. A small indentation which the intermediate ring would cause near the outer circumference of the plastic back-up ring should be of no consequence. The tests would show also whether a slightly thicker plastic back-up ring would be beneficial.



APPENDIX XII

REPORT 05-249 Addendum VII INVESTIGATION OF THE OPERATION OF THE REVENOC  
18158/CAST-IRON BACK-UP SYSTEM AT 450°F. REVIEW OF THE RESULTS OF TESTS  
PERFORMED AT 275°F, 350°F AND 450°F - NOV. 30, 1973

1.0 INTRODUCTION

- 1.1 The subject of this report is an analysis of operation of the piston seal assembly consisting of an O-ring and of the back-up rings a plastic one and a metal one mounted in tandem. The test reported here was basically a repetition of a 1000 hours test discussed in the Report 05-249 Addendum V and VI, except that the maximum operational temperature was increased here from 350°F to 450°F.

2.0 BACKGROUND

2.1 Components Tested

The same as specified in 2.1.1 of the Report 05-249 Addendum V.

2.2 Test Fluid per MIL-H-83282.

2.3 Operational Conditions

2.3.1 Fluid pressure range 50-4000 psi. The 4000 psi pressure was applied at each second full cycle.

2.3.2 Temperature Range - 30°F to 450°F.

2.4 Occurances During the Test

2.4.1 Excessive fluid leakage through the rear seal of the piston #1 was noticed after 46,800 operational cycles. The cylinder #1 was removed for inspection. The test continued with cylinders #2 and #3.

2.4.2 After 55,200 operational cycles an excessive leakage appeared at the rear seal of the piston #3. The test was terminated and the cylinders #2 and #3 were removed for inspection.

2.4.3 The data recorded during the above tests are specified in Appendix I to this Report.

3.0 DISCUSSION OF THE TESTS AND TEST RESULTS

- 3.1 The test discussed in this report was of exploratory nature. The intent was to obtain preliminary information on the behaviour of the components of the piston seal now under development when exposed to 450°F maximum operating temperature. This temperature requested by the contractor was set arbitrarily. Neither information was available whether the MIL-H-83282 test fluid was suitable for operation at 450°F, nor available were the data on the degradation of physical properties of the materials for the O-rings and the back-up rings at that temperature.

Although the 1000 hours test following the procedure adopted for the present development tests could not be completed with 450°F maximum temperature because of seals' failures, valuable information was obtained. This information is being analyzed below:

The detailed report on the conditions of each seal component inspected after the test is presented in Appendix 2. To be of real value the above information should be compared with the information collected on inspection of components tested at lower temperatures, particularly at 350°F.

The Report No. 05-249 and Addenda 1, 11, 111, 1V, V and VI were issued after completion of particular tests and reflect the progress of the development effort. To avoid the necessity of going through this copious material a summary of information obtained from all previous tests will be given here. This summary will state the present stage of development of the seal components designed for operation at 350°F. It will serve also as base for evaluation of seal operation at 450°F.

3.2 Tests at 275°F Maximum Operating Temperature and at Pressure Cycling Between 50 psi and 3000 psi

The seals using single back-up rings made of Tetralon 720 or Revonoc 18158 material completed successfully the required tests and remained functional after 1000 hours operation including over 100,000 pressure cycles.

Those back-up rings which would not adapt themselves to the depth of the pertinent glands as easily as the softer back-up rings made of virgin Teflon had to be mounted with .002 to .006 interference fits with the depth of glands. This provided a reserve material for the initial breaking-in of the rings and eliminated the danger of creating a gap at the bottom of the piston groove. Such a gap would cause extrusion and erosion of the O-rings.

The diametral clearances between the cylinder bores and the pistons varied between .002 and .006. Thus a maximum gap against which a back-up ring might extrude could be as large as .006 in case of an off center position of the piston. After an initial breaking-in period, the back-up rings adapted themselves to the cylinder bores and their wear was very slow.

At the post-test inspection small extrusion lips, not longer than .005, were found at the external circumferences of the back-up rings at the side opposite to the O-ring. The width of the lips varied between .001 and .005.

The surfaces contacting the cylinder bores were smooth and shiny without scratches. No distortion of the back-up rings was noticeable.

The results of tests performed at a maximum temperature of 275°F and at a maximum pressure of 3000 psi indicate that the Tetralon 720 and the Revonoc 18158 back-up rings would operate satisfactorily under these conditions for very long period of time and would provide a full protection for the O-rings.

All the tests conducted within this program were performed on seals designed for a 1.241 cylinder bore diameter. It is believed that the change of the cylinder bore diameter would affect the operation of the back-up rings only as far as it would alter the magnitude of the clearance fits between the cylinder bore and the piston.

The range of diametral clearances (.006 maximum) investigated during the above tests would cover the clearance fit ranges applicable in most of the precision built hydraulic components of moderate size. To cover the cases of components with more liberal tolerances or the cases of cylinder wear and ovalisation which sometimes have to be tolerated in service, additional tests on suitable modified fixtures would be required.

3.3 Tests at 350°F Maximum Operating Temperature and at Pressure Cycling between 50 psi and 4000 psi

3.3.1 The Revonoc 18158 back-up rings were used in all tests discussed below. This selection was dictated by the delivery time which was much shorter than that for the Tetralon 720 back-up rings.

The tests conducted earlier on a Chew Test Rig demonstrated that the degradation with the increasing temperature of the modulus and of the compression strength of the Revonoc material would at 350°F and at 4000 psi fluid pressure, cause a rapid extrusion of the Revonoc back-up rings through the clearances existing between the cylinder bore and the piston. Since reduction of these clearances might jeopardize the operation of the rig and would be not acceptable for conventional hydraulic components, the back-up system was modified by introduction of a second metal back-up ring. Such a ring was made of high grade pearlitic cast-iron possessing high resistance to wear, low coefficient of friction and the coefficient of linear thermal expansion virtually identical with the cylinder material. It could be easily manufactured and could be operated with .001 to .003 clearance fit with the cylinder bore, provided that it was mounted floatingly in the piston groove. That was achieved by providing a liberal clearance fit (.015-.018) between the ring inner circumference and the bottom of the piston groove.

It was anticipated that the material of the Revonoc back-up ring would extrude into the gap so created, but since the gap was blind, closed by the groove wall, the extrusion would stop after the gap was filled.

The above system and the test performed with it are described in the Report No. 05-249 Addenda V and VI.

The test was 67% successful. The cylinder #1 had to be removed from the test rig after 62,400 operational cycles because of the excessive leakage through the front seal. The remaining cylinders #2 and #3 completed successfully the 1000 hours test.

The leakage of the test fluid through the front seal of the cylinder #1 was due to a local erosion of the O-ring which in turn was caused by a large indentation in the Revonoc back-up ring. The indentation was caused by the loss of the of the back-up ring material through extrusion into the gaps between the cylinder bore and the cast-iron ring and between the cast-iron ring and the bottom of the piston groove.

The rear seal in the cylinder #1 was still functional, but the deterioration of the Revonoc back-up rings indicated that it might not last much longer. (See Figure 1 through Figure 3 in the Report No. 05-249 Addendum V).

The examination of the seal components retrieved after termination of tests permitted a reconstruction of the sequence of events, which ultimately led to a localized wear of the cast-iron ring and to a localized weakening of the cross section of the Revonoc back-up ring, the cause of its failure.

If heating of the seal under pressure started with the piston off center with respect to the cylinder bore (a usual occurrence) the extrusion of the Revonoc back-up ring into the large gap between the cast-iron ring and the bottom groove would begin sooner and would proceed at a faster rate at the location where the gap was the widest. That would create a radially directed force which would push the cast-iron ring in the direction opposite to the off-center position of the piston.

Thus the ability of the cast-iron ring to float would work to our disadvantage. The ring would rub against the cylinder bore at one location opening at the opposite side a gap equal to the total diametral clearance fit. See Report No. 05-299 Addenda V and VI.

The conditions of the seal components inspected after termination of the test discussed above indicated that the lateral shift of the cast-iron ring occurred in a majority of cases, causing an uneven wear and in one case the destruction of the Revonoc rings.

The effect of the width of the gap between the cylinder bore and the cast-iron back-up ring on the progress of Revonoc ring extrusion throughout the operation at 350°F and under 4000 psi fluid pressure could be only tentatively estimated upon the results of one test.



It appears however that with the gap of and below .0005, the extrusion augmented by the drag of the moving cylinder bore surface might be close to zero. With the gap in the vicinity of .001 the extrusion might be slow enough to permit completion of a 1000 hours test. With a gap above .002 the extrusion might become critical.

3.3.2 The following modifications to increase the operational life of the seals were implemented and are being tested:

3.3.2.1 An intermediate .015 thick metal ring centered on the bottom of the piston groove was installed between the Revonoc back-up ring and the cast-iron ring. (See Report No. 05-249 Addendum VI) By providing a close fit with the bottom of the groove (.002 diametral clearance) the ring should admit to the gap between the cast-iron ring and the bottom of the groove only a limited amount of Revonoc material in a form of thin shreds, thus preventing creation of the lateral push on the cast-iron ring.

3.3.2.2 The thickness of the Revonoc back-up ring was doubled. That should make more material available for feeding the extrusion lip without distorting and weakening the cross section of the back-up ring.

3.4 Tests at 450°F Maximum Operating Temperature and at Pressure Cycling Between 50 psi and 4000 psi

The sequence of the events leading to the fixture of the rear seal in the piston #1 and of the rear seal in the piston #3 was similar to that discussed in 3.3, except that the rate of extrusion was much higher and the distortion and destruction of the seal components was more severe than that observed after the tests performed at the maximum temperature of 350°F.

Figure 1 shows the cross section through the Revonoc back-up ring of the rear seal of the piston #3. This seal failed after 55,200 operational cycles (See 2.4. and Appendix 1)

The failure occurred at the usual place where the gap between the cylinder bore and the cast-iron ring was the widest and the gap at the bottom of the piston groove the narrowest. Before the breakdown the width of the Revonoc back-up ring was reduced from .052 to .035. The flow of material towards the extruded lips is clearly visible on Figure 1. There were some indentations and indications of erosion on the back-up ring. The conditions of its surface could not be determined because the back-up ring was coated with a blackish film, probably the residue of the oxidized test fluid. Pits and cracks were apparent however at the damaged section of the back-up ring of the rear seal of the piston #1.

In both cases the sections of the O-rings adjacent to the damaged sections of the back-up rings were deeply eroded losing 25% to 75% of the material.

All O-rings were completely remolded. Their cross sections assumed the shape of a capital D with the flat side towards the back-up rings and the semi-cylindrical side towards the fluid. That was a natural shape which an initially amorphous cross section would assume under identical load conditions. It indicated a loss of the resistance of the O-ring material to plastic flow; By contrast the O-rings made of the same V747-75 compound tested at the maximum temperature of 350°F retained their circular cross section with only an insignificant permanent set. The V747-75 O-rings remolded to the D cross section retained their sealing ability at the room and at the elevated temperatures. They were extruded however and lost 25% - 75% of their material at the locations where the eroded and crushed Revonoc back-up ring deprived them of support.

The cast-iron rings showed a little deeper, but still smooth and shiny wear marks. However tiny scratches in the axial direction were noticeable across the wear marks in case of the two piston seals.

#### 4.0 CONCLUSIONS AND RECOMMENDATIONS

The following improvements would be necessary before the back-up system discussed above could be considered as fully operational:

- 4.1 For the back-up system consisting of a plastic and a cast-iron ring suitable for operation at 350°F:
  - 4.1.1 Bring to a successful conclusion the test performed at present to eliminate the lateral force on the cast-iron rings and to increase the volume of spendable material of the Revonoc back-up rings.
  - 4.1.2 Increase gradually the clearance fit between the cylinder bore and the cast-iron ring to determine the maximum fit at which the back-up system could operate for a reasonable period of time.
- 4.2 The operational temperatures higher than 350°F should be determined by the availability of the hydraulic fluid capable of operation at these temperatures without decomposition. Curves determining degradation of physical properties with increase of temperature shall be determined for the seal and the back-up ring materials within the range of the intended operational temperatures.

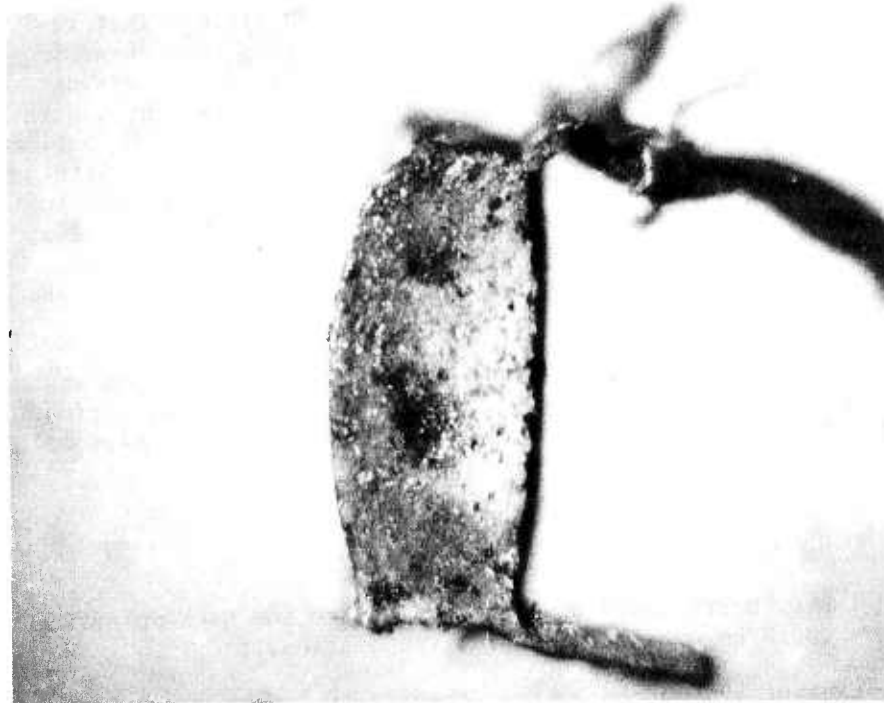

Figure 1.

APPENDIX XIII  
REPORT 05-249 Addendum VIII EVALUATION OF INTERMEDIATE RING TO REDUCE  
EXTRUSION ON HIGH TEMPERATURE HIGH PRESSURE SYSTEMS - NOV. 30, 1973

1.0 BACKGROUND

- 1.1 The purpose of the test discussed in this report was to check the effectiveness of the intermediate ring ML-1322 proposed and discussed in detail in the Report 05-249 Addendum VI and in Addendum VII, Paragraph 4.1.

The details of the back-up system including this ring are shown on Figure 1 and Figure 2 (the same figures for both Addendum VI and VIII).

As additional improvement two Revonoc 18158 back-up rings ML-1295 were mounted in tandem between the O-ring and the intermediate ring. The rings were mounted with the usual interference fit .001-.005 between the depth of the groove of the Retainer ML-1202 and the width of the ring. The width of the groove (in the axial direction) was increased from  $.250 \pm .010$  to  $.330 \pm .002$  to accomodate the second ML-1295 back-up ring.

2.0 TEST CONDITIONS

2.1 Components Tested

- 2.1.1 2-214 O-rings of the V747-75 compound  
2.1.2 ML-1295 Revonoc 18158 back-up rings two per seal  
2.1.3 ML-1322 Intermediate rings  
2.1.4 ML-1299 Cast Iron Back-up Rings  
2.1.5 2-218 O-rings of the V747-75 compound installed as wipers.

2.2 Test Fluid: per MIL-H-83282

2.3 Test Procedure

As per Appendix 1.

Maximum pressure 4000 psi

Maximum temperature 350°F

Minimum temperature -30°F

The test was performed on cylinder #1 mounted in the environmental chamber.

3.0 DISCUSSION OF THE TEST RESULTS

- 3.1 Reference is made here to the Report 05-249 Addendum VII Paragraph 3.3.2 where the modifications tested here were described and discussed.

- 3.2 The intermediate ring ML-1322, the function of which was to reduce and make harmless the extrusion of the material of the plastic ring into the gap between the cast-iron ring and the bottom of the groove, performed better than it was expected. With the close fit between the intermediate ring and the bottom of the groove (.002 diametral clearance), no material was extruded into the above gap. (See Appendix 2 Paragraph 1.1.3 and 1.2.3)

However a certain amount of localized wear was found on the outer circumference of the cast-iron rings. Although this wear was smaller than that which occurred in all cases, where the intermediate ring was not installed, it nevertheless indicated that the cast-iron rings operated in a slightly off-center position.

- 3.3 The tests performed up to date indicated that at 275°F only a thin film of the plastic back-up ring's material would be pulled into the .006 maximum gap between the cylinder bore and the off-center piston. The extrusion was here of mechanical nature caused by the drag of the moving cylinder bore wall. The film broke into fringes and the lateral force spread over a large sliding area of the piston causing no wear. The material of the Tetralon 720 or Revonoc 18158 back-up rings was hard enough as not to form a static extrusion lip.
- 3.4 At 350°F however the degradation of the modulus and of the compression strength of the Revonoc back-up ring was such that under a combined action of 4000 psi fluid pressure and of the drag of the cylinder bore wall the extrusion lip could be formed even when the extrusion gap was reduced to .002 - .003 by addition of a floating cast-iron ring.
- 3.5 It was impossible either to predict or to control the off-center position which the floating cast-iron ring would assume with respect to the cylinder bore within its .001 - .003 diametral clearance fit. In all cases the initial off-center position of the cast-iron ring was sufficient to cause an uneven extrusion of the plastic back-up rings material between the cylinder bore and the cast-iron ring. That in turn pushed the cast-iron ring to its extreme off-center position within its clearance fit. However, the extrusion lip was never found longer than .030 and it appeared that it reached its limit.

With the elimination of the concurrent lateral force originating in the inner gap (See 3.2) the local wear of the cast-iron ring became very small.

3.6 The second modification, that is doubling the volume of the Revonoc back-up ring, proved to be successful. Since no rings thicker than .050 were available, two ML-1295 Revonoc rings each .050 thick were mounted in tandem. Figure 3, which is a cross section through these rings photographed after completion of the test indicates that the extrusion of the outboard ring affected the inboard ring very little and the support of the O-ring was fully maintained.

4.0 CONCLUSIONS AND RECOMMENDATIONS

4.1 The tests performed up-to-date seem to indicate that a back-up ring system consisting of a Revonoc 18158 back-up ring .100 thick, or of two .050 thick rings, of an intermediate ring and a cast-iron ring would remain operational after completion of the standard 1000 hour test at 350°F and possibly at a higher maximum temperature. The system would provide a full protection for an O-ring of a suitable compound.

The tests of such a system shall be pursued vigorously.

4.2 Further study of the cast-iron back-up ring and particularly of its fit with the cylinder bore shall be conducted. With the addition of the intermediate ring a split cast-iron ring may offer interesting possibilities and these possibilities shall be thoroughly investigated.

4.3 The recommendations of the Paragraph 4.2 of the Report 05-249 Addendum VII shall be carried out.

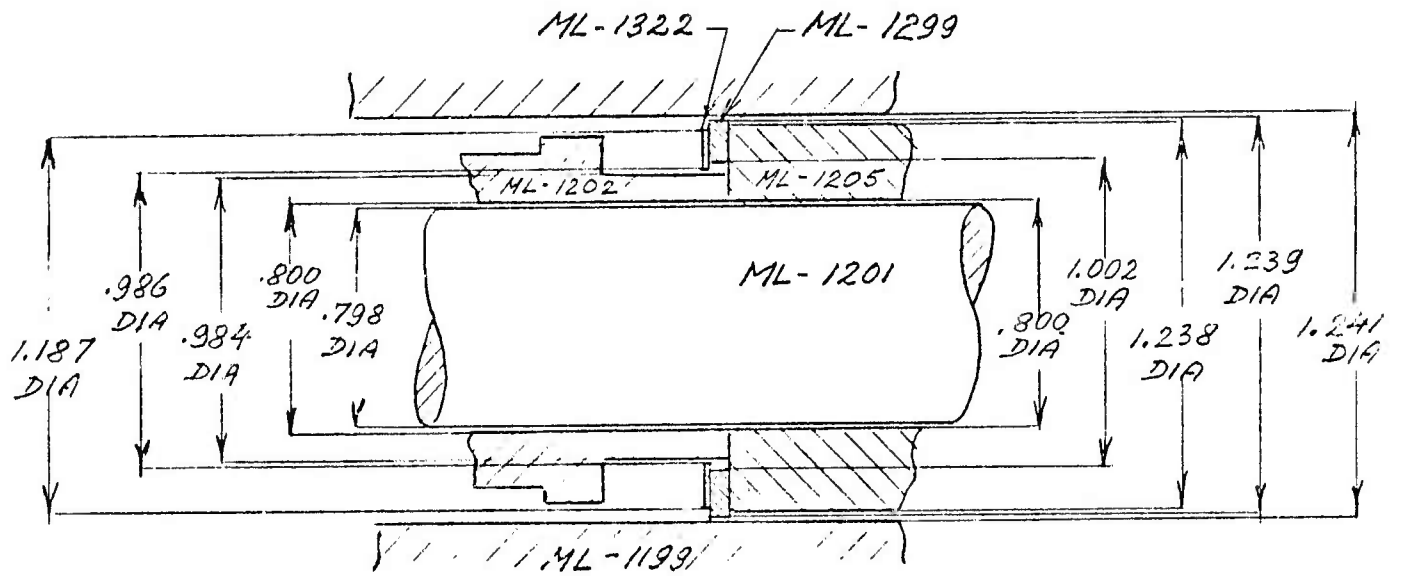

CYLINDER NO. 1.

FIG. 1.

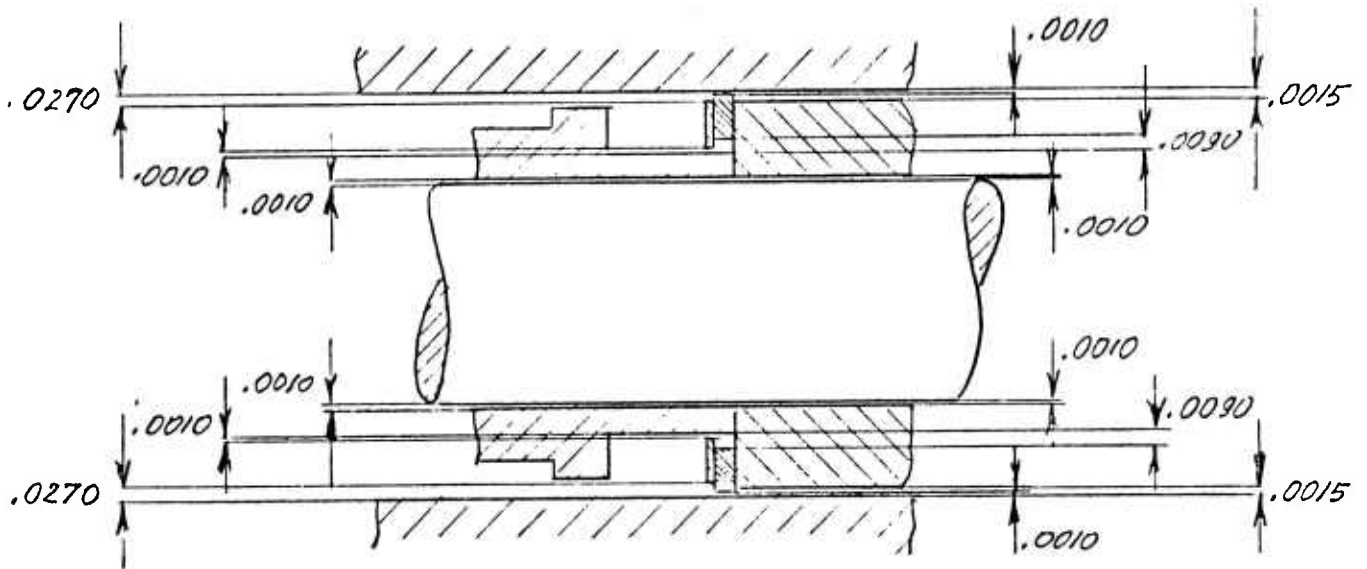

FIG. 2.

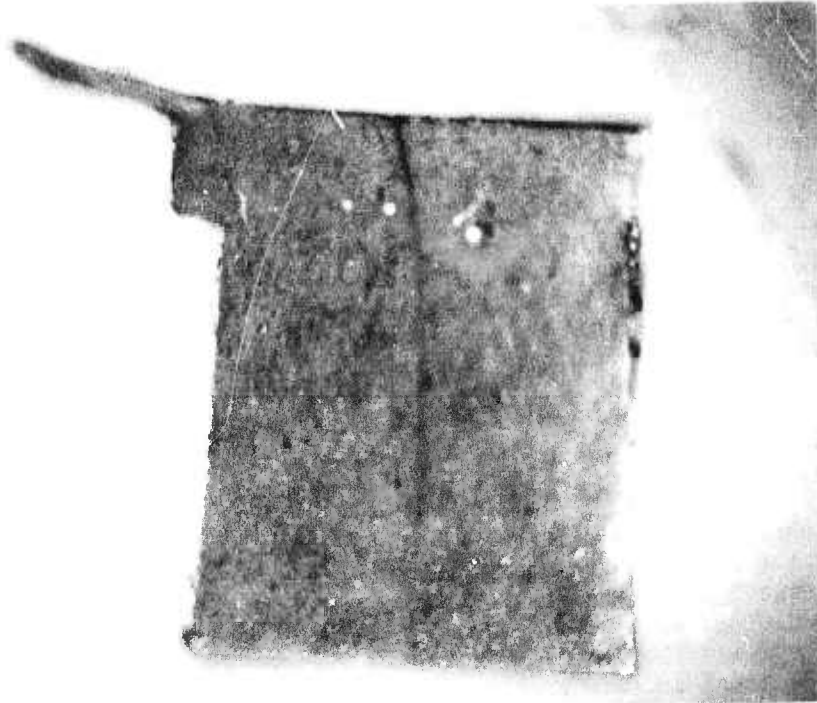

Figure 3.



APPENDIX XIV

REPORT 05-249 Addendum IX EVALUATION OF PARKER COMPOUND V747-75 AT 400°F,  
IN MIL-H-83282, 4000 PSIG USING CAST-IRON/REVENOC 18158 BACK-UPS  
FEB. 25, 1974

1.0 BACKGROUND

- 1.1 The piston seals consisting of the V747-75 O-rings, the Revonoc 18158 back-up rings, and the cast-iron supporting back-up rings were tested successfully at 4000 psi cycling pressure and at 350°F maximum temperature. They failed, however, after approximately 400 hours when subjected to a standard 1000 hours test at 450°F.
- 1.2 This report discusses the conditions of the seal components inspected after a 1000 hours test of 4000 psi cycling pressure and 400°F maximum temperature. This test was terminated before its completion because of excessive leakage of the front seal in the Cylinder #2 at the 6th operational cycle and of the front seal in the Cylinder #1 at the 7th operational cycle. The whole test consists of ten operational cycles. Each cycle contains sixteen hours of cold soak and eight hours of operation at the maximum test temperature and pressure. (See Appendix 1)
- 1.3 Each seal in the piston #1 with widened grooves consisted of an O-ring, of two Revonoc 18158 back-up rings, of one intermediate ring, and of one cast-iron ring. (See Figure 1)

The narrower grooves in the pistons #2 and #3 could accommodate only one Revonoc back-up ring and one cast-iron ring (See Fig. 2 and Fig. 3). The charts Figure 1, Figure 2 and Figure 3 show the main dimensions of the grooves and of the seal components. They also specify the ratio of the cross section area of the O-ring to the cross section area of the net portion of the groove.

2.0 CONCLUSIONS

- 2.1 It appears that 400°F was still a too high temperature for the V747-75 O-rings. At that temperature the O-rings took a high permanent set and their circular cross section assumed the shape of capital D with the flat side leaning against the back-up rings. This remolding did not impair the O-rings ability to seal. However, the sharp corners at the O-rings outer circumference wedged between the moving surface of the cylinder bores and the static back-up rings became a subject of an accelerated wear by nibbling. Some O-rings became locally distorted to compensate for the lost material and the nibbling continued until the O-rings lost their ability to seal.
- 2.2 The Revonoc back-up rings behaved as it was expected and their performance was satisfactory. The latest modifications as doubling the width of the plastic back-up rings and addition of the intermediary metal ring seemed to be beneficial to the seal performance.

2.3 The temperature of 400°F seemed to be too high for the MIL-H-83282 test fluid. All the seal components inspected after the test were coated with black sticky material which appeared to be a product of the decomposed test fluid, possibly mixed with the small particles of the worn O-ring material.

3.0 TEST PROCEDURE

3.1 Components Tested

3.1.1 2-214 O-rings of the V747-75 compound

3.1.2 Back-up rings of Revonoc 18158 as per Figure 1, Figure 2 and Figure 3.

3.2 Test Fluid

Per MIL-H-83282

3.3 Operational Conditions

3.3.1 Fluid pressure range 50-4000 psi. The 4000 psi pressure was applied at each second full cycle.

3.3.2 Temperature Range -30°F to 400°F

3.4 Occurrences During the Test

See Appendix 1.

3.5 Seal Inspection After Test

See Appendix 2.

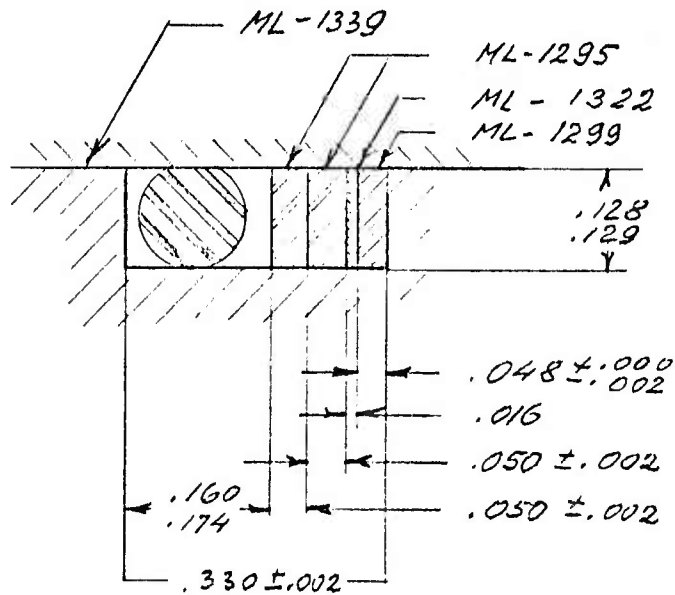

CYLINDER # 1  
LOW SQUEEZE 4% - 12%

VOLUME OF THE GLAND CAVITY [NET]

$$0.160 \times 0.128 \times 1.115 \times \pi = 0.07174 \text{ in}^3$$

$$0.174 \times 0.129 \times 1.115 \times \pi = 0.07863 \text{ in}^3$$

VOLUME OF THE O-RING WITH 15% ADDED FOR THERMAL EXPANSION & SWELL. MOLDING TOLERANCES OMITTED [V = 2.4674 \* D \* W<sup>2</sup> \* N15]

$$V = 2.4674 \times 1.123 \times 0.01932 \times 1.15 = 0.0615 \text{ IN}^3$$

VOLUME FILL

$$\frac{0.0615}{0.07174} = 0.8573 = 86\% \text{ MAX.}$$

$$\frac{0.0615}{0.07863} = 0.7782 = 78\% \text{ MIN.}$$

FIG. 1.

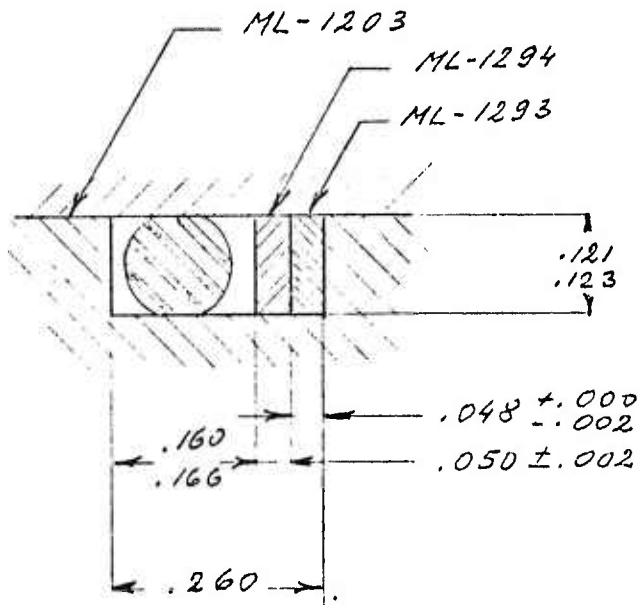

CYLINDER # 2  
NORMAL SQUEEZE  
9% - 15%

VOLUME OF THE GLAND CAVITY [NET]

$$0.160 \times 0.121 \times 1.120 \times \pi = 0.0681 \text{ IN}^3$$

$$0.166 \times 0.123 \times 1.120 \times \pi = 0.0718 \text{ IN}^3$$

VOLUME OF THE O-RING WITH 15% ADDED FOR THERMAL EXPANSION & SWELL. MOLDING TOLERANCES OMITTED [V = 2.4674 \times D \times W^2 \times 1.15]

$$V = 2.4674 \times 1.123 \times 0.01932 \times 1.15 = 0.0615 \text{ IN}^3$$

VOLUME FILL

$$\frac{0.0615}{0.0681} = 0.9031 = 90\% \text{ MAX}$$

$$\frac{0.0615}{0.0718} = 0.8566 = 86\% \text{ MIN}$$

FIG. 2

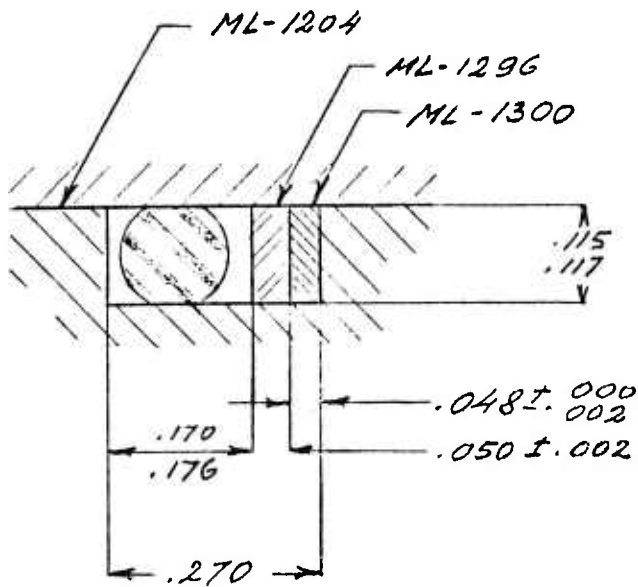

CYLINDER #3  
TIGHT SQUEEZE  
13% - 19%

VOLUME OF THE GLAND CAVITY [NET]

$$0.170 \times 0.115 \times 1.126 \times \pi = 0.0692 \text{ IN}^3$$

$$0.176 \times 0.117 \times 1.126 \times \pi = 0.0728 \text{ IN}^3$$

VOLUME OF THE O-RING WITH 15% ADDED FOR THERMAL EXPANSION & SWELL. MOLDING TOLERANCES OMITTED [V = 2.4674 \* D \* W<sup>2</sup> \* 1.15]

$$V = 2.4674 \times 1.123 \times 0.0192 \times 1.15 = 0.0615 \text{ IN}^3$$

VOLUME FILL

$$\frac{0.0615}{0.0692} = 0.889 = 89\% \text{ MAX}$$

$$\frac{0.0615}{0.0728} = 0.8448 = 84\% \text{ MIN}$$

FIG. 3