

UNANNOUNCED

1

INVENTORY

AD-A995 244

DTIC ACCESSION NUMBER

LEVEL

AEC-WT-546 Mar 1953

DOCUMENT IDENTIFICATION

DISTRIBUTION STATEMENT A

Approved for public release
Distribution Unlimited

DISTRIBUTION STATEMENT

ACCESSION FOR

NTIS GRA&I

DTIC TAB

UNANNOUNCED

JUSTIFICATION

BY

DISTRIBUTION /

AVAILABILITY CODES

DIST

AVAIL AND/OR SPECIAL

A-1

DISTRIBUTION STAMP



DTIC
ELECT
S FEB 14 1985 D

DATE ACCESSIONED

DATE RETURNED

83 0411

DATE RECEIVED IN DTIC

REGISTERED OR CERTIFIED NO.

PHOTOGRAPH THIS SHEET AND RETURN TO DTIC-DDAC

SECRET

This document consists of 145 pages
No. 288 of 290 copies, Series A

OPERATION TUMBLER

Project 8.6

**SOUND VELOCITY CHANGES NEAR
THE GROUND IN THE VICINITY OF
AN ATOMIC EXPLOSION**

REPORT TO THE TEST DIRECTOR

by

R. C. McLoughlin

March 1953

U. S. Navy Electronics Laboratory
San Diego 52, California

AD-A995 244

SECRET

SECRET

DISCLAIMER NOTICE

THIS DOCUMENT IS BEST QUALITY PRACTICABLE. THE COPY FURNISHED TO DTIC CONTAINED A SIGNIFICANT NUMBER OF PAGES WHICH DO NOT REPRODUCE LEGIBLY.

[REDACTED]

C. 288A
DEFENSE NUCLEAR
AGENCY
TECHNICAL LIBRARY
DIVISION
25 JAN 1983

This document contains information affecting the national defense of the United States within the meaning of the Espionage Laws, Title 18 U. S. C. Sections 793 and 794. The transmission or the revelation of its contents in any manner to an unauthorized person is prohibited by law.

Statement A
Approved for public release;
Distribution unlimited *Mark D. [Signature] 2/12/85*
Acting Chief, ISCD

[REDACTED]

**Reproduced Direct from Manuscript Copy by
AEC Technical Information Service
Oak Ridge, Tennessee**

**Inquiries relative to this report may be made to
Chief, Armed Forces Special Weapons Project
P. O. Box 2610
Washington, D. C.**

**If this report is no longer needed, return to
AEC Technical Information Service
P. O. Box 401
Oak Ridge, Tennessee**

[REDACTED]

ABSTRACT

0.1 OBJECTIVE

The objective of this project was to determine the velocity of sound at altitudes of 1 $\frac{1}{2}$, 10 and 54 feet above the ground level at distances^{1/} of 0, 1500, 3000, 4500 and 6000 feet from ground zero in the interval from detonation to shock wave arrival when various yield atomic weapons are detonated in the air at different altitudes.

0.2 GENERAL PROCEDURE

The procedure consists of measuring the travel time of acoustic signals between pairs of electroacoustic transducers situated at the aforementioned locations.

The transducers face each other with a 3-foot^{2/} distance between their diaphragms. The transmitter in every case faces directly away from ground zero.

0.3 MAJOR RESULTS AND CONCLUSIONS

0.3.1 Tumbler 1 and 2

No useful data were obtained on either of these tests due to instrument failures.

0.3.2 Tumbler 3 and 4

The most important part of the data in this report is that expressing the velocity in the 50 milliseconds before shock wave arrival at the various transducer locations. Rounded off figures for these velocities appear in tables 0.1 and 0.3. For more complete data see tables C.1 through D.23 or figs 3.1 through 3.17.

^{1/} Tumbler 1 distances were 0, 500, 1000, 1500 and 2000 feet. In Tumbler 2, distances were the same as for Tumbler 3 and 4 with one extra point 750 feet from ground zero.

^{2/} 1.99 Feet interdiaphragm distance for Tumbler 4.

TABLE 0.1

Tumbler 3, Velocities Before Shock Wave Arrival (ft/sec)

Elev (ft)	Tower 7-200	Tower 7-202	Tower 7-204	Tower 7-206	Tower 7-208
54	1200	1140	1130	1130	(3)
10	1400 ⁴	1200	1150	1130	(3)
1 $\frac{1}{2}$	1500	1300-1600 ⁴	1200	1220	(3)

TABLE 0.2

Tumbler 3, Ground Distances of NEL Instruments from Target Ground Zero in Feet

Tower 7-200	Tower 7-202	Tower 7-204	Tower 7-206	Tower 7-208
147	1404	2902	4401	5901

(3) Not operating
4 On and off

TABLE 0.3

Tumbler 4, Velocities Before Shock Wave Arrival (ft/sec)

Elev (ft)	Tower 7-200	Tower 7-202	Tower 7-204	Tower 7-206	Tower 7-208
54	1300 ± 150 ⁵	1100-1300	1120	1130	1150
10	1500 ^{5 6 7}	(8)	1150	1150	1130
1½	1400 ± 200 ^{5 7}	2400 ± 400	(8)	1260	1140

TABLE 0.4

Tumbler 4, Ground Distances of NEL Instruments from Target Ground Zero in Feet

Tower 7-200	Tower 7-202	Tower 7-204	Tower 7-206	Tower 7-208
207	1342	2839	4338	5837

- 5 On and off
- 6 Approximate figure
- 7 Very few data
- (8) Failed at detonation

SECRET

The general impressions gained from study of the NEL data in figures 3.1 through 3.17 are as follows:

1. The velocity of sound increases in an erratic manner for close in points at elevations up to 54 feet soon after detonation.
2. Although there is wild velocity fluctuation with time, there appears to be a steady trend which can often be correlated with temperature changes recorded by NRDL.
3. The variations from the temperature trend are attributed at least partly to air movements. The NRDL temperature data contain great variations too, but it is expected that temperature gradients exist in the air masses blowing by.
4. As expected, the average velocity is greatest near the hot ground and decreases with height up to 54 feet. It is also greatest near ground zero, but not at ground zero (see 7).
5. Velocity below ambient is recorded in the rarefaction pressure phase. There are at least two possible causes for this: (a) Temperature is below ambient, (b) The wind is blowing from receiving transducer to transmitting transducer. Consequently, the NEL velocities are less than those that would be obtained if temperature data were the only determinants of acoustic velocity.
6. The opposite of 5 is true during the compression phase. Velocities recorded by NEL are higher than those that would be obtained by calculations based solely on temperature data. This is due to the air flow at this time from transmitting transducer to receiving transducer.
7. Although the temperatures $1\frac{1}{2}$ feet above the ground are probably greater at 7-200 than at tower 7-202 a greater material velocity (along the instrument line) at 7-202 produces a greater recorded velocity.

0.4 RECOMMENDATIONS

0.4.1 Plot of Shock Wave Ray Paths

The application of the Project 1.2 pressure vs time data and the Project 8.6 acoustic velocity vs time data gives the shock wave velocity in the regions of refraction from the Rankine-Hugoniot equation. It seems possible to construct shock wave ray paths on scaled drawings and show thereby the probable path of the shock waves near the ground.

[REDACTED]

0.4.2 Correlation of Acoustic Velocity, Temperature and Wind Data

Preceding the shock wave arrival, the acoustic velocity data should be correlated with temperature and wind data taken at the same locations, since the acoustic velocity contains both of these pieces of information.

0.4.3 Elimination of 54 ft Elevation Measurements

The velocity information obtained from the 54-foot elevation transducers has not proved to be commensurate with the required expenditures of materials and man power. It is recommended that velocity meters should measure air at elevations no higher than 15 feet in subsequent tests of this same type.

It is recommended that section 2.3 and chapter 4 be read before any interpretation of the results given in chapter 3 is attempted.

ACKNOWLEDGMENTS

Dr. A. B. Focke was the Project 8.6 Leader. Mr. H. C. Silent, engineering consultant, assumed the responsibilities of equipment design. Much praise is due the people who completely designed, built, and installed the equipment in less than 2 months, operated it in the field and later interpreted the copious data.

ROSTER OF PERSONNEL

A. J. Bloom	Installation and field operation
A. M. Cargile	Installation, field operation and liaison
W. D. Campbell	Design, installation, purchase and field operation
J. R. Chiles	Design, installation and field operation
O. E. Crispell	Data analysis
D. D. Crowell	Installation
W. E. Elms	Installation and liaison
A. B. Focke	Project Leader 8.6, administration, installation and consulting
F. C. Foushee	Installation and analysis
D. E. Holcomb	Design, installation and field operation
C. T. Johnson	Administration, installation and liaison
R. C. McLoughlin	Design, installation and data analysis
G. O. Pickens	Design, installation and field operation
J. E. Rusconi	Installation and data analysis
J. N. Shellabarger	Administration, installation and liaison
H. C. Silent	Design, installation, field operation and consulting
L. C. Thompson	Installation and liaison
C. P. Wiedow	Installation

~~SECRET~~
CONTENTS

ABSTRACT	3
0.1 Objective	3
0.2 General Procedure	3
0.3 Major Results and Conclusions	3
0.3.1 Tumbler 1 and 2	3
0.3.2 Tumbler 3 and 4	3
0.4 Recommendations	6
0.4.1 Plot of Shock Wave Ray Paths	6
0.4.2 Correlation of Acoustic Velocity, Temperature and Wind Data	7
0.4.3 Elimination of 54 ft Elevation Measurements	7
PREFACE	9
ACKNOWLEDGMENTS	9
CONTENTS	11
ILLUSTRATIONS	13
TABLES	14
CHAPTER 1 OBJECTIVE	17
1.1 Purpose of Project 8.6	17
1.2 Authority for Project 8.6	17
CHAPTER 2 BACKGROUND AND INSTRUMENT THEORY	18
2.1 Background	18
2.2 General Instrument Theory	18
2.3 Specific Instrument Theory	19
2.3.1 Explanation	19
2.3.2 Instrument Locations	20
2.3.3 Records	20
2.3.4 NEL Sound Velocity Meter	21
CHAPTER 3 RESULTS	37
CHAPTER 4 DISCUSSION	53
4.1 Noise	53
4.1.1 Seismic Shock	53
4.1.2 Electromagnetic Transients	53
4.1.3 Transducer Movements	53

4.1.4	Acoustic Noises in the 10 Kc Region	53
4.1.5	Wind Noise	54
4.1.6	Reflection and Refraction Effects	54
4.1.7	Turbulence	55
4.1.8	Noise Signals on Paper Tapes	56
4.2	Accuracy	57
4.2.1	Velocity Error Due to Cool Air in Transducers	57
4.2.2	Velocity Error Due to Horn Effect	57
4.2.3	Velocity Error in Reading Spike Spacing	60
4.3	Calibration	60
4.4	Small Energy Losses Due to Turbulence and Winds	61
CHAPTER 5	CONCLUSIONS AND RECOMMENDATIONS	63
5.1	Tumbler 3 and 4 Data	63
5.2	Tumbler 1 and 2 Data	64
5.3	Equipment Improvement	64
5.3.1	Concrete Rooms	64
5.3.2	Immediate Data at Test Site	64
APPENDIX A	DETAILS OF INSTRUMENTATION	67
A.1	Statement	68
A.2	Five Hundred Cycle per Second Signal Generator	68
A.3	Oscillator - Modulator - Amplifier Unit	69
A.4	Demodulator Unit	70
A.5	Phase Discriminator	71
A.6	Relay Control System	72
A.6.1	General Description	72
A.6.2	Normal Operation	72
A.6.3	Possible Operation	72
A.7	Time Mark Generator	73
APPENDIX B	SOUND FREQUENCY CONSIDERATIONS	83
B.1	Statement	84
B.2	Early Philosophy	84
B.3	Acoustic Noise	84
B.4	Destructive Interference	85
APPENDIX C	TUMBLER 3 AND 4 ACOUSTIC VELOCITY VS TIME TABLES FOR INTERVALS FROM DETONATION TO 4 SECONDS (OR MORE) AFTERWARDS	87
APPENDIX D	TUMBLER 3 AND 4 ACOUSTIC VELOCITY VS TIME TABLES FOR INTERVAL OF 50 MILLISECONDS BEFORE SHOCK WAVE ARRIVAL	125
BIBLIOGRAPHY	138

~~SECRET~~
REF ID: A661546

~~SECRET~~

[REDACTED]

ILLUSTRATIONS

2.1	Electroacoustic Transducers of NEL Velocity Meter	24
2.2	Typical Voltage Spikes	24
2.3	Reference and Acoustically Delayed Spikes	24
2.4	Short Pole and Low Level Transducers	25
2.5	Transducers on High Pole	25
2.6	Ground Zero Layout	26
2.7	7-202 Layout	26
2.8	7-204 Layout	27
2.9	7-206 Layout	27
2.10	7-208 Layout	28
2.11	Along the Blast Line	29
2.12	Closeup of Coffin Hole	29
2.13	Velocity Vs Time Field Records Tumbler 2	30
2.14	Velocity Vs Time Field Records Tumbler 3	31
2.15	Velocity Vs Time Field Records Tumbler 4	32
2.16	Magnetic Tape to Film Record System	33
2.17	Reference and Acoustic Spikes	33
2.18	Unit Diagram of Sound Velocity Measuring System	34
2.19	NEL Paper Recorders	35
2.20	NEL Magnetic Recorder Panel	36
3.1	Acoustic Velocity Vs Time Curves Tumbler 3, Tower 200	38
3.2	Acoustic Velocity Vs Time Curves Tumbler 3, Tower 202	39
3.3	Acoustic Velocity Vs Time Curves Tumbler 3, Tower 204	40
3.4	Acoustic Velocity Vs Time Curves Tumbler 3, Tower 206	41
3.5	Acoustic Velocity Vs Time Curves Tumbler 4, Tower 200	42
3.6	Acoustic Velocity Vs Time Curves Tumbler 4, Tower 202	43
3.7	Acoustic Velocity Vs Time Curves Tumbler 4, Tower 204	43
3.8	Acoustic Velocity Vs Time Curves Tumbler 4, Tower 206	44
3.9	Acoustic Velocity Vs Time Curves Tumbler 4, Tower 208	45
3.10	Acoustic Velocity Vs Time Curves Tumbler 3, Tower 200	46
3.11	Acoustic Velocity Vs Time Curves Tumbler 3, Tower 202	47
3.12	Acoustic Velocity Vs Time Curves Tumbler 3, Tower 204	48
3.13	Acoustic Velocity Vs Time Curves Tumbler 3, Tower 206	49
3.14	Acoustic Velocity Vs Time Curves Tumbler 4, Tower 202	50
3.15	Acoustic Velocity Vs Time Curves Tumbler 4, Tower 204	50
3.16	Acoustic Velocity Vs Time Curves Tumbler 4, Tower 206	51
3.17	Acoustic Velocity Vs Time Curves Tumbler 4, Tower 208	52
4.1	Refraction Due to Hot Air Surrounding Receiver	61
4.2	Artificial Noise Test	62
4.3	Noise Test at Tower 202	62
A.1	500 cps. Signal Generator Block Diagram	74
A.2	500 cps. Signal Generator Schematic	75
A.3	10 kc. Oscillator Modulator Unit Block Diagram	76
A.4	10 kc. Oscillator Modulator Unit Schematic	77
A.5	Demodulator Unit Block Diagram	78

~~SECRET~~

A.6	Demodulator Unit Schematic	78
A.7	Phase Discriminator Block Diagram	79
A.8	Phase Discriminator Schematic	79
A.9	Relay Control Diagram Schematic	80
A.10	Time Mark Generator Block Diagram	80
A.11	Time Mark Generator Schematic	81

TABLES

0.1	Tumbler 3	Velocities Before Shock Wave Arrival (ft/sec) . . .	4
0.2	Tumbler 3	Ground Distances of NEL Instruments from Target Ground Zero in Feet	4
0.3	Tumbler 4	Velocities Before Shock Wave Arrival (ft/sec) . . .	5
0.4	Tumbler 4	Ground Distances of NEL Instruments from Target Ground Zero in Feet	5
4.1		Probable Errors Due to Cool Air in Transducers	58
4.2		Velocity Errors for Two NEL Velocity Meters for Temperatures from 70° to 200°F	59
5.1		Correlation of NEL Velocity Data and NRDL Temperature Data	65
C.1	Velocity Vs Time Tumbler 3	Tower 200 Elevation 54 Ft . .	88
C.2	Velocity Vs Time Tumbler 3	Tower 200 Elevation 10 Ft . .	89
C.3	Velocity Vs Time Tumbler 3	Tower 200 Elevation 1½ Ft . .	90
C.4	Velocity Vs Time Tumbler 3	Tower 202 Elevation 54 Ft . .	91
C.5	Velocity Vs Time Tumbler 3	Tower 202 Elevation 10 Ft . .	92
C.6	Velocity Vs Time Tumbler 3	Tower 202 Elevation 1½ Ft . .	93
C.7	Velocity Vs Time Tumbler 3	Tower 204 Elevation 54 Ft . .	95
C.8	Velocity Vs Time Tumbler 3	Tower 204 Elevation 10 Ft . .	96
C.9	Velocity Vs Time Tumbler 3	Tower 204 Elevation 1½ Ft . .	97
C.10	Velocity Vs Time Tumbler 3	Tower 206 Elevation 54 Ft . .	98
C.11	Velocity Vs Time Tumbler 3	Tower 206 Elevation 10 Ft . .	99
C.12	Velocity Vs Time Tumbler 3	Tower 206 Elevation 1½ Ft . .	100
C.13	Velocity Vs Time Tumbler 4	Tower 200 Elevation 54 Ft . .	101
C.14	Velocity Vs Time Tumbler 4	Tower 200 Elevation 10 Ft . .	102
C.15	Velocity Vs Time Tumbler 4	Tower 200 Elevation 1½ Ft . .	104
C.16	Velocity Vs Time Tumbler 4	Tower 202 Elevation 54 Ft . .	105
C.17	Velocity Vs Time Tumbler 4	Tower 202 Elevation 10 Ft . .	107
C.18	Velocity Vs Time Tumbler 4	Tower 202 Elevation 1½ Ft . .	108
C.19	Velocity Vs Time Tumbler 4	Tower 204 Elevation 54 Ft . .	109
C.20	Velocity Vs Time Tumbler 4	Tower 204 Elevation 10 Ft . .	110
C.21	Velocity Vs Time Tumbler 4	Tower 206 Elevation 54 Ft . .	112
C.22	Velocity Vs Time Tumbler 4	Tower 206 Elevation 10 Ft . .	114
C.23	Velocity Vs Time Tumbler 4	Tower 206 Elevation 1½ Ft . .	116
C.24	Velocity Vs Time Tumbler 4	Tower 208 Elevation 54 Ft . .	118
C.25	Velocity Vs Time Tumbler 4	Tower 208 Elevation 10 Ft . .	120
C.26	Velocity Vs Time Tumbler 4	Tower 208 Elevation 1½ Ft . .	122

~~SECRET~~

~~SECRET~~

D.1	Velocity Vs Time Tumbler 3	Tower 200	Elevation 54 Ft	. . . 126
D.2	Velocity Vs Time Tumbler 3	Tower 200	Elevation 10 Ft	. . . 126
D.3	Velocity Vs Time Tumbler 3	Tower 200	Elevation 1½ Ft	. . . 127
D.4	Velocity Vs Time Tumbler 3	Tower 202	Elevation 54 Ft	. . . 127
D.5	Velocity Vs Time Tumbler 3	Tower 202	Elevation 10 Ft	. . . 128
D.6	Velocity Vs Time Tumbler 3	Tower 202	Elevation 1½ Ft	. . . 128
D.7	Velocity Vs Time Tumbler 3	Tower 204	Elevation 54 Ft	. . . 129
D.8	Velocity Vs Time Tumbler 3	Tower 204	Elevation 10 Ft	. . . 129
D.9	Velocity Vs Time Tumbler 3	Tower 204	Elevation 1½ Ft	. . . 130
D.10	Velocity Vs Time Tumbler 3	Tower 206	Elevation 54 Ft	. . . 130
D.11	Velocity Vs Time Tumbler 3	Tower 206	Elevation 10 Ft	. . . 131
D.12	Velocity Vs Time Tumbler 3	Tower 206	Elevation 1½ Ft	. . . 131
D.13	Velocity Vs Time Tumbler 4	Tower 200	Elevation 1½ Ft	. . . 132
D.14	Velocity Vs Time Tumbler 4	Tower 202	Elevation 54 Ft	. . . 132
D.15	Velocity Vs Time Tumbler 4	Tower 202	Elevation 1½ Ft	. . . 133
D.16	Velocity Vs Time Tumbler 4	Tower 204	Elevation 54 Ft	. . . 133
D.17	Velocity Vs Time Tumbler 4	Tower 204	Elevation 10 Ft	. . . 134
D.18	Velocity Vs Time Tumbler 4	Tower 206	Elevation 54 Ft	. . . 134
D.19	Velocity Vs Time Tumbler 4	Tower 206	Elevation 10 Ft	. . . 135
D.20	Velocity Vs Time Tumbler 4	Tower 206	Elevation 1½ Ft	. . . 135
D.21	Velocity Vs Time Tumbler 4	Tower 208	Elevation 54 Ft	. . . 136
D.22	Velocity Vs Time Tumbler 4	Tower 208	Elevation 10 Ft	. . . 136
D.23	Velocity Vs Time Tumbler 4	Tower 208	Elevation 1½ Ft	. . . 137

~~SECRET~~

CHAPTER 1

OBJECTIVE

1.1 PURPOSE OF PROJECT 8.6

An analysis of the air blast pressures of Operation Buster in October 1951 indicated that magnitudes in the high pressure regions were approximately one third those predicted from the use of isobaric curves of height of burst versus distance when applied to atomic blast data obtained since 1948. A general theory was advanced by Lt. Colonel Porzel as a possible cause for this. It consisted of two parts, a thermal theory and a mechanical effects theory.

The thermal theory implied that a high temperature layer of air exists near the ground after detonation and the subsequent shock wave is thereby refracted. The mechanical effects theory postulated the dissipation of energy in turbulence and other air flow, and energy absorption by the ground and the dust particles in the air.

On 10 January 1952 the Joint Chiefs of Staff authorized Operation Tumbler to obtain further information on the blast effects of atomic weapons. One phase of this was Project 8.6, the determination of acoustic velocities near the ground in the vicinity of an atomic explosion. Following this the conversion from regular acoustic velocity to shock wave velocity can then be accomplished theoretically and a possible path of the shock wave near the earth's surface constructed.

A comparison of the data with temperature measurements made by other Program activities will yield the component of wind velocities in the direction of the blast line. A further use of the data is that of determining the kinetic energy contained in the turbulent air masses.

1.2 AUTHORITY FOR PROJECT 8.6

Authority for the participation of the U. S. Navy Electronics Laboratory^{9/} in this project is contained in the following Secret-Restricted Data letters:

<u>From</u>	<u>To</u>	<u>Date</u>	<u>Serial</u>
Chief, Naval Operations	Chief, Bureau of Ships	11 Jan. 1952	001IP36
Chief, Bureau of Ships	CNO	22 Jan. 1952	348RDO071
Chief, Bureau of Ships	Commanding Officer and Director, USNEL	22 Jan. 1952	348RDO070

^{9/} Hereafter referred to as NEL

BACKGROUND AND INSTRUMENT THEORY

2.1 BACKGROUND

NEL's instrument for measuring sound velocity is an adaptation of the acoustic interferometer.^{10/} The latter is generally concerned with higher frequencies but the principles are the same.

Figure 2.1 shows the transducer pair used by NEL. This, with its associated electronic equipment is the NEL velocity meter.

2.2 GENERAL INSTRUMENT THEORY

The measurement of a velocity always involves the measurement of a travel time over a known displacement. The velocity of sound can be determined by separating the diaphragms of a transmitting and receiving electroacoustic transducer pair by a known amount and by measuring the time that elapses as a wave travels from the transmitter's diaphragm to the receiver's diaphragm. To simplify the discussion, a system much simpler than that actually used will be described first.

Assume that a series of voltage spikes is generated and fed directly to a transmitting transducer. Assume that there are 500 of these generated per second and that their shape is like those shown in fig 2.2. A receiving transducer whose diaphragm is 3 feet away from that of the transmitter will receive a series of pressure spikes and will then put out a corresponding series of voltage spikes. If the voltage spikes entering and leaving the transducer pair were now to be viewed on a cathode ray oscilloscope there would be an observable time differential between the spikes' entrance into the transducer four terminal network and their emergence therefrom.

For simplicity imagine that the air between transducers is so cold that the velocity of sound is only 1000 feet per second. If this were true, the time for the spike to cross the 3 ft air gap between transducer diaphragms would be 3 msec for:

$$\Delta t_a = \frac{d}{v} = \frac{3}{1000} \text{ Secs} \qquad \text{Eq. (2.1)}$$

Where Δt_a is acoustic time delay in seconds, d is distance between transducer diaphragms in feet, v is velocity of sound in feet/second.

^{10/} See references 1 and 7, bib.

[REDACTED]

If one observes this phenomenon on the scope one sees a picture like that of fig 2.3.

Here the primed spikes refer to those which have left the receiver (the "acoustic" spikes) and the unprimed spikes are those which are about to enter the line to the transmitter (the "reference" spikes). A glance at the figure shows that the acoustic spike does not occur at 3 msec after its reference spike, but rather occurs at $3 + \Delta t_{em}$ msec later. The quantity Δt_{em} is the electromechanical time delay and is a result of the fact that the electrical circuit contains time delay elements (anything that shifts phase will do it), and the transducers with their mechanical circuits contain time delay elements too. However, once Δt_{em} is known, this device becomes a velocity measuring instrument. For the purpose of project 8.6 it is sufficient to measure Δt_{em} by measuring the temperature just before the start of the test. This temperature has corresponding acoustic velocity and hence acoustic time delay over a known distance. This acoustic time delay is then subtracted from the total time delay at the start of the test (the distance AA' or BB' in fig 2.3.), which latter is measured experimentally, and the result is Δt_a . It is then assumed that Δt_{em} remains constant during the test. If Δt (total) is defined as the interval between a reference and its associated acoustic spike (e.g., the interval AA' or BB', etc), then

$$\Delta t \text{ (total)} = \Delta t_a + \Delta t_{em} \quad \text{Eq. (2.2)}$$

Δt (total) is measured experimentally at any time when velocity is to be determined during the test.

Δt_{em} is already known from predetonation measurements (ambient temperature condition).

Therefore, Δt_a is now determined for any time during the test

$$\text{Therefore, } v = \frac{d}{\Delta t_a} \quad \text{Eq. (2.3)}$$

and velocity is determined for any time during the test.

2.3 SPECIFIC INSTRUMENT THEORY^{11/}

2.3.1 Explanation

Although the basic ideas set forth in 2.1 above are es-

^{11/} This section is intended primarily for the data analyst. It is not essential for the reader desiring only general information, as the preceding paragraph will suffice. On the other hand, the reader desiring greater detail will wish to refer to the instrumentation section of the appendix.

~~SECRET~~

entially correct, the techniques actually employed are slightly different and more information is required to interpret the data realistically.

2.3.2 Instrument Locations

The NEL transducers are situated at elevations of $1\frac{1}{2}$, 10, and 54 ft above ground level with the $1\frac{1}{2}$ and 10 ft units attached to one 12 ft vertical pole devoted exclusively to NEL, with the 54 ft unit mounted on a 55 ft pole and shared by other activities. Coupling between the transducers and the vertical poles is effected by 2-inch steel pipes and adjustable clamps. See figures 2.1, 2.4, and 2.5. Transmitting transducers face away from ground zero and towards their own vertical poles in all cases.

The locations of the transducers are named 7-200, 7-202, 7-204, 7-206, and 7-208. The 7-200 location is the bombardier's target area and is called instrument ground zero.^{12/} The physical set-up is depicted in figures 2.6 through 2.10. Field equipment consisting of a modulator, demodulator and power supply is housed in a large wooden coffin at each location (one coffin serving the transducer pairs at three elevations). Figure 2.11 shows a view of blast line looking towards ground zero. Coffin is in foreground. Figure 2.12 is a close-up of hole with instruments on top of coffin. Wires run back underground to a control van which is 12,000 ft along the blast line from 7-200.

2.3.3 Records

The NEL records as they come from the control van are of two types:

1. Inked paper records with time as the abscissa and acoustic velocity as the ordinate, the so-called Brush tapes. See figures 2.13 through 2.15.

2. Magnetic tape records of voltage spikes like those shown in figure 2.3. The magnetic tape records are not used in this form but are played back on a magnetic head, amplified and fed to a cathode ray oscilloscope with a blue trace tube.^{13/} The set-up is shown in fig 2.16. No sweep voltage is used on the oscilloscope. The scope picture is photographed by a high speed camera. The speed of the film gives the time effect of a sweep voltage and the film picture of the spikes is like that of fig 2.17. These latter data are used for determining the records of figures 3.1 through 3.17 and tables C.1 through D.23 by the method described in section 2.2.

^{12/} Actual ground zero is ground point directly under bomb.

^{13/} A 5LP 11 will do.

2.3.4 NEL Sound Velocity Meter

The block diagram of the sound velocity measuring system is shown in fig 2.18. The sequence of operations of this equipment is as follows:

1. At -15 min EGG^{14/} closes a relay which turns on the time mark generator, phase discriminators and 500 cps generator.
2. At -5 min EGG closes a relay which turns on the field unit power supplies, and the Brush paper recorders and Magnecorder 2-channel magnetic recorders.
3. At detonation an electromagnetic transient due to the blast enters the lines and makes a mark of "true zero time" on all NEL records. See fig 2.17.
4. At detonation plus the amount of time required for the EGG relay plus the NEL relay to close,^{15/} a 3 Kc time pulse which is on for 5.87 secs and off for 0.13 secs and is recorded on the magnetic tape record, is switched so that it is now on for 0.13 secs and off for 5.87 secs. See fig 2.17. This gives a convenient way of finding zero time quickly on the magnetic records.
5. Also a time mark on the Brush paper records which has a positive polarity for 5.87 seconds and a negative polarity for 0.13 seconds, followed by positive 5.87 secs again, then negative 0.13 secs, etc, is changed to negative polarity for 5.87 seconds and positive for 0.13 secs. This occurs at same time as change in 4 above.

Five Hundred Cycle Per Sec Signal Generator

When the equipment is once turned on the following processes occur. The 500 cps signal generator sends 500 cps sine waves down each of 5 lines to the transducer locations. The generator also produces voltage spikes whose peaks have a one to one correspondence to zero phases (where wave crosses axis with a positive slope) of the aforementioned sine waves. These spikes go to the phase discriminator where they are compared for time delay with the zero phases of the waves which have gone to and returned from the field.

Oscillator-Modulator

The 500 cps sine waves amplitude modulate a 10 Kc carrier and the modulated wave then enters the terminals of an electro-

^{14/} Edgerton, Germeshausen and Grier

^{15/} 12 msec on Tumbler 3. See fig. 2.17
6 msec on Tumbler 4.

~~SECRET~~

acoustic transmitting transducer.^{16/} This loudspeaker's diaphragm then emits a sound wave which is received by the diaphragm of another transducer.^{16/} The interdiaphragm distance is 3 ft.^{17/} The modulated wave from the receiving transducer then travels over wires to the demodulator.

Demodulator

Here the signal passes through a 9 to 11 Kc band pass filter for the purpose of noise suppression.

The demodulator demodulates the signal received and sends back by underground wire to the control van the 500 cps voltage sine wave.

Phase Discriminator

The 500 cps sinusoid now enters the phase discriminator. Here it is converted into voltage spikes by the successive processes of amplifying, clipping, differentiating and rectifying. A glance at fig 2.18 shows the phase discriminator feeding information to two recorders. Consider first the magnetic recorder. The spikes just manufactured from the sine wave returning from the field now energize one grid of a mixer, another grid is energized by those coming from the 500 cps generator. The mixer's output is therefore a series of "reference spikes" (from the 500 cps generator) and 2 msec apart, and following these is a series of "acoustic spikes" whose lag behind the reference spikes is a measure of the time required for them to travel over the electrical, mechanical and acoustic circuit. Assuming no changes in the electrical and mechanical circuit elements during the test, the only changes in acoustic spike time position will be due to time delays in the acoustic air path. This is a measure of velocity (see section 2.2). The two mixed series of spikes are now recorded directly on a magnetic tape recorder.

The displacement of the pen in the Brush magnetic oscillograph (paper recorder) is directly proportional to the velocity in the air gap. This is accomplished by an Eccles-Jordan "flip-flop" circuit followed by an integrating circuit which includes the Brush pen motor. One half of the "flip-flop" is energized by the reference spikes, the other half by the acoustic spikes. When a reference spike comes in, only one half of the Eccles-Jordan circuit is conducting and the other half is waiting for its acoustic spike. When the latter arrives,

^{16/} Altec-Lansing 802-B high frequency loud speaker.

^{17/} Except on Tumbler 4 when it is 1.99 ft.

██████████

the second half of the circuit conducts and the first half is waiting for a reference spike. The integrator is a memory device whose output pen displacement is a function of how long each half of the circuit is conducting, and hence a function of the acoustic time delay which is in turn a function of the velocity in the air gap.

Recorders

The paper recorder used is a 6-channel unit. Three recorders were used. They are a special type designed and built by NEL. However, they do use the Brush magnetic pen motors and Brush 6 channel recording paper. See fig 2.19. The magnetic recorders are Magnecorder binaural type magnetic tape recorders, Type PT 63-AH. They run at speeds of 15"/sec. See fig 2.20.



Fig. 2.1 Electroacoustic Transducers of NEL Velocity Meter

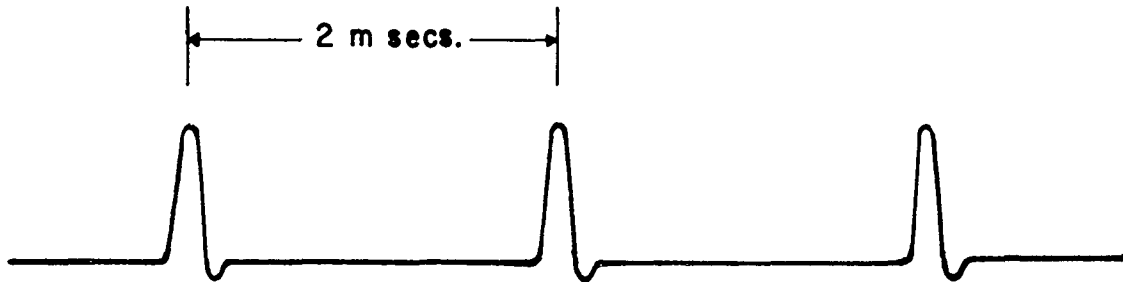

Fig. 2.2 Typical Voltage Spikes

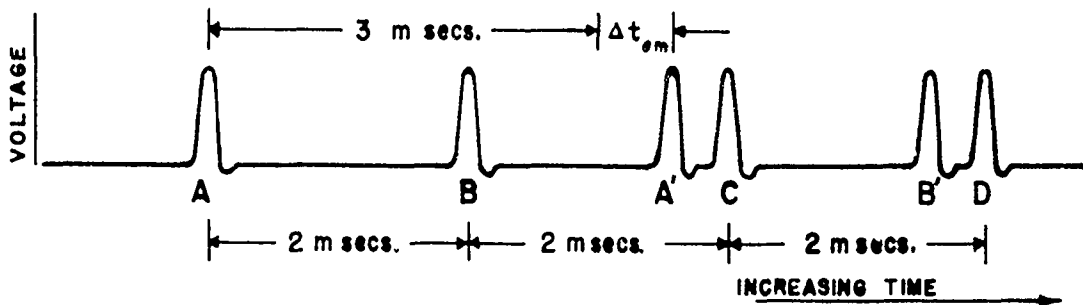

Fig. 2.3 Reference and Acoustically Delayed Spikes

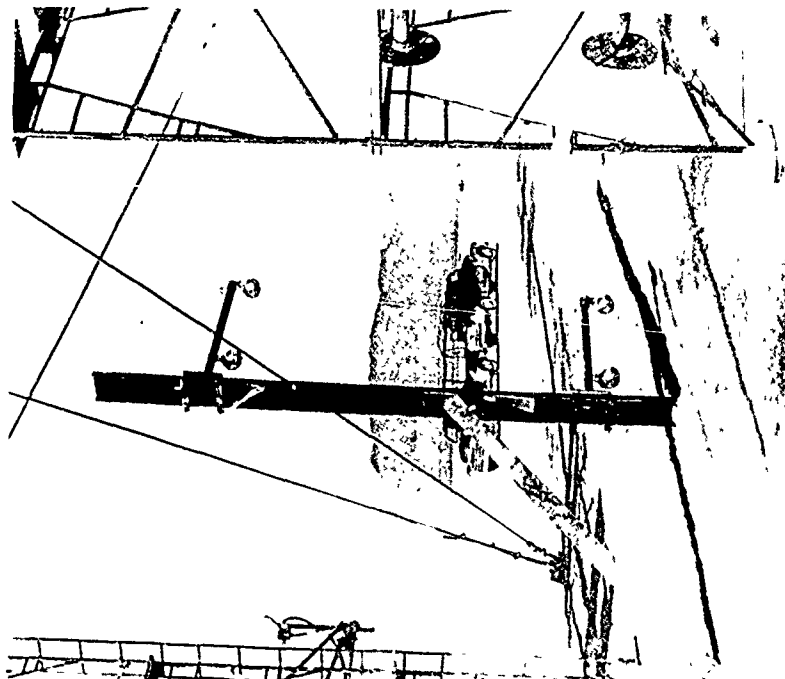

Fig. 2.4 Short Pole and Low Level Transducers

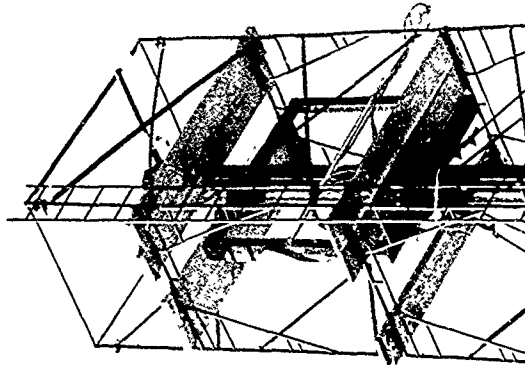

Fig. 2.5 Transducers on High Pole

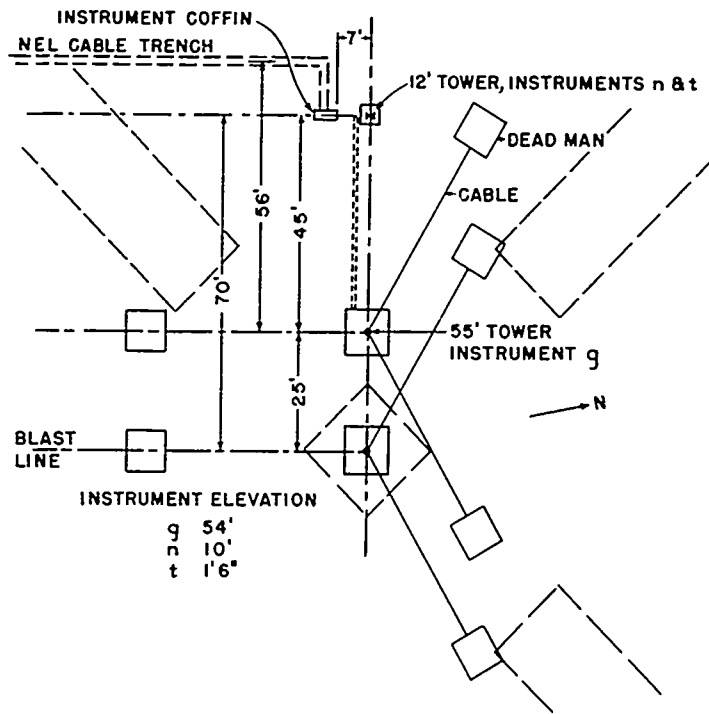

Fig. 2.6 Ground Zero Layout

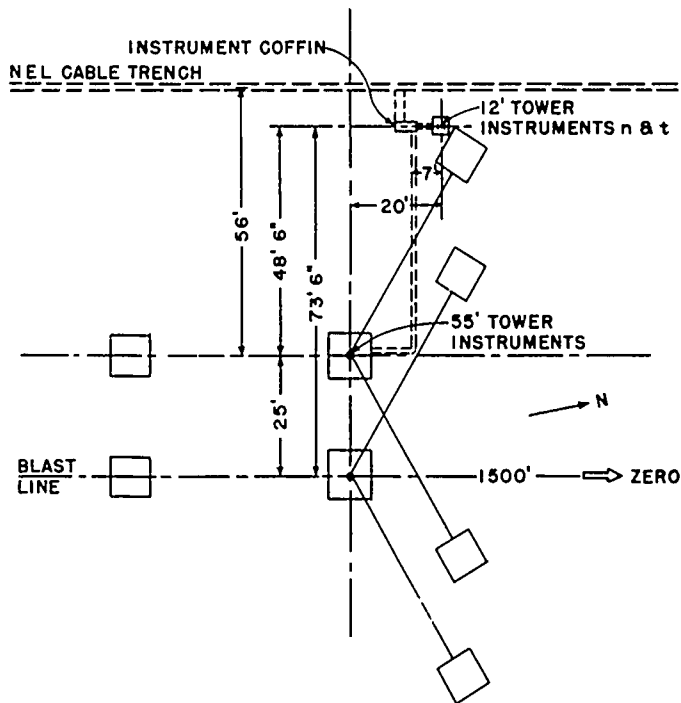

Fig. 2.7 7-202 Layout

~~SECRET~~

~~SECRET~~

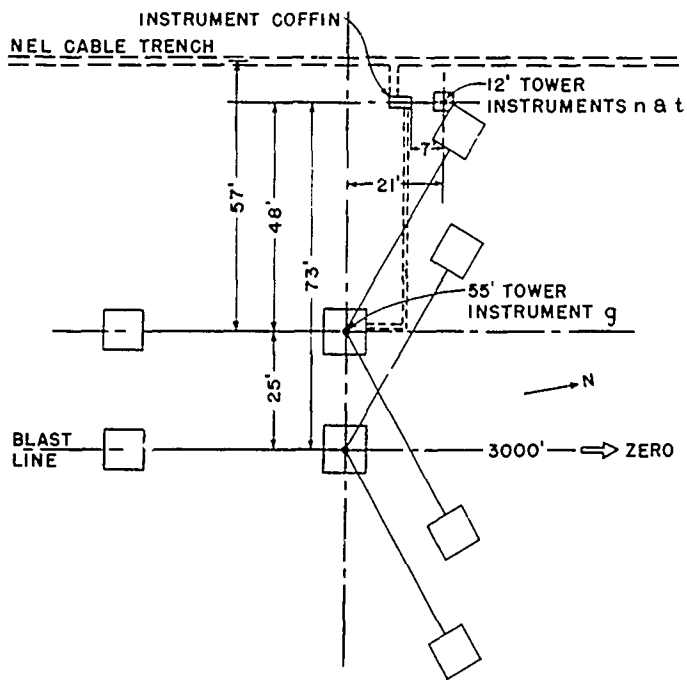

Fig. 2.8 7-204 Layout

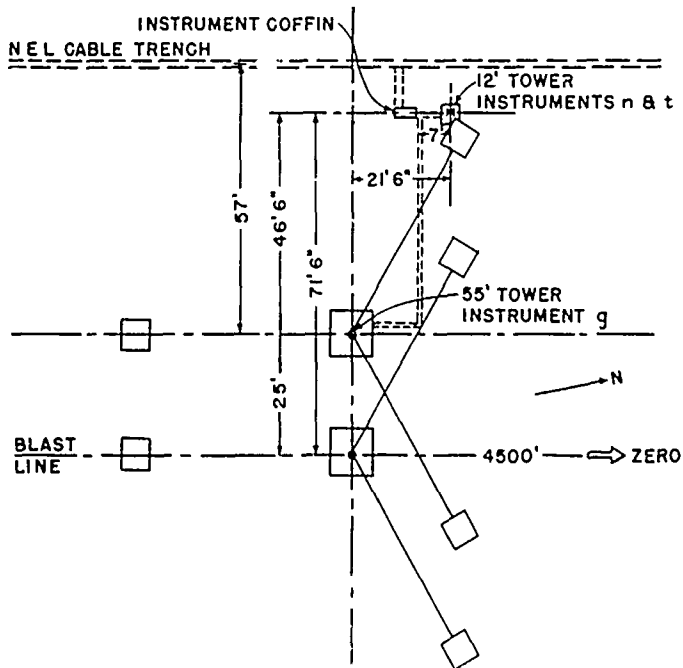

Fig. 2.9 7-206 Layout

~~SECRET~~

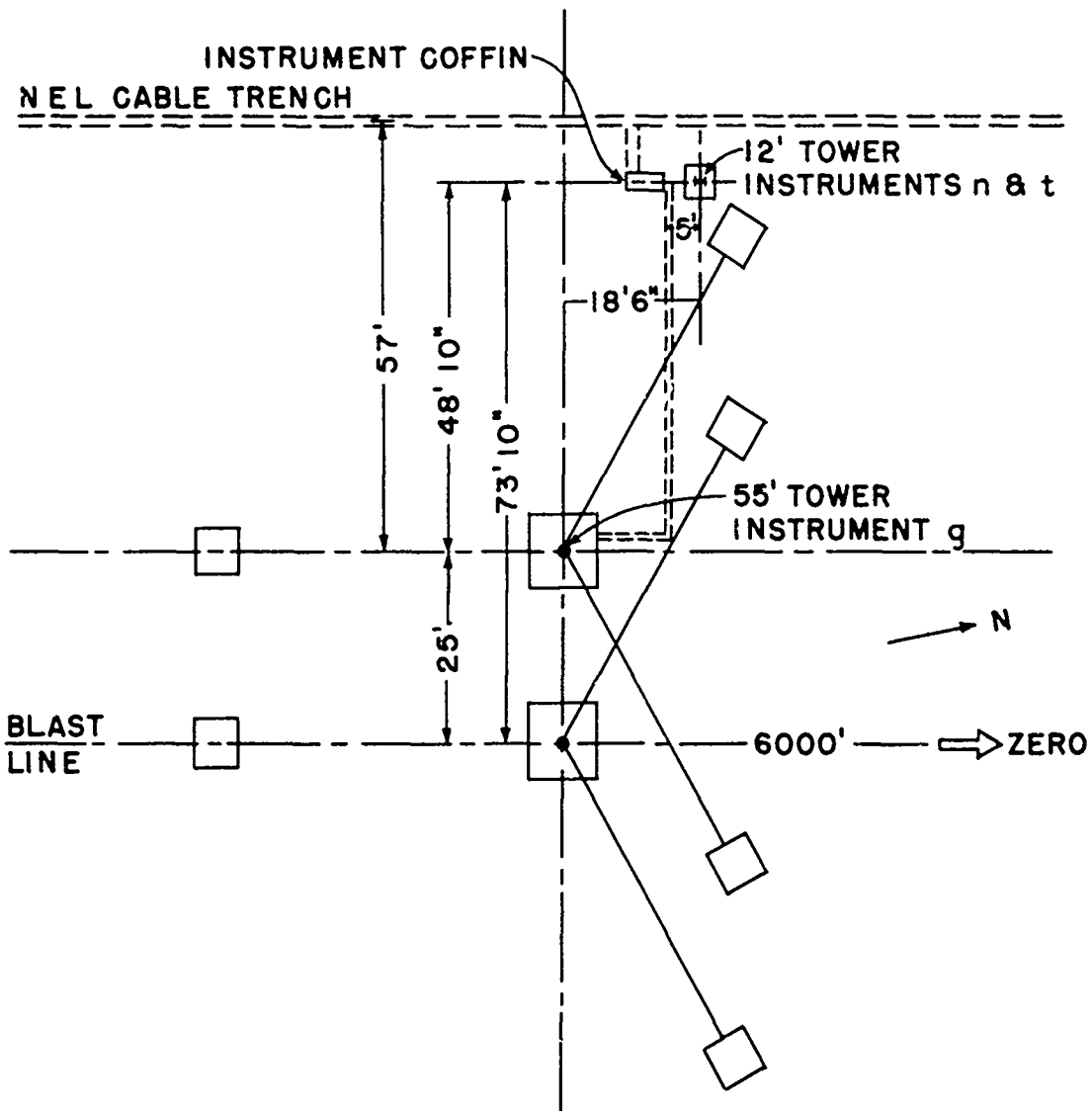

Fig. 2.10 7-208 Layout

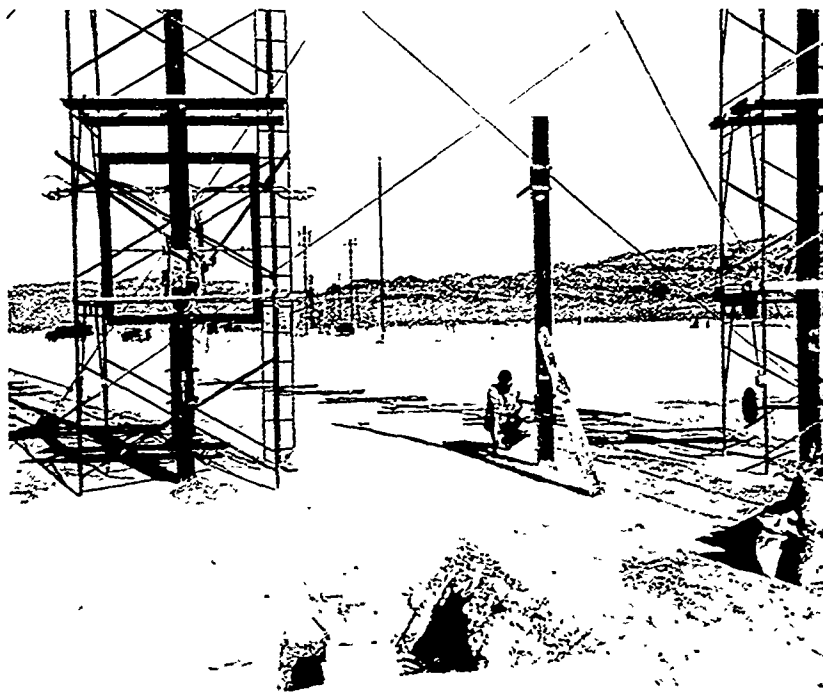

Fig. 2.11 Along the Blast Line

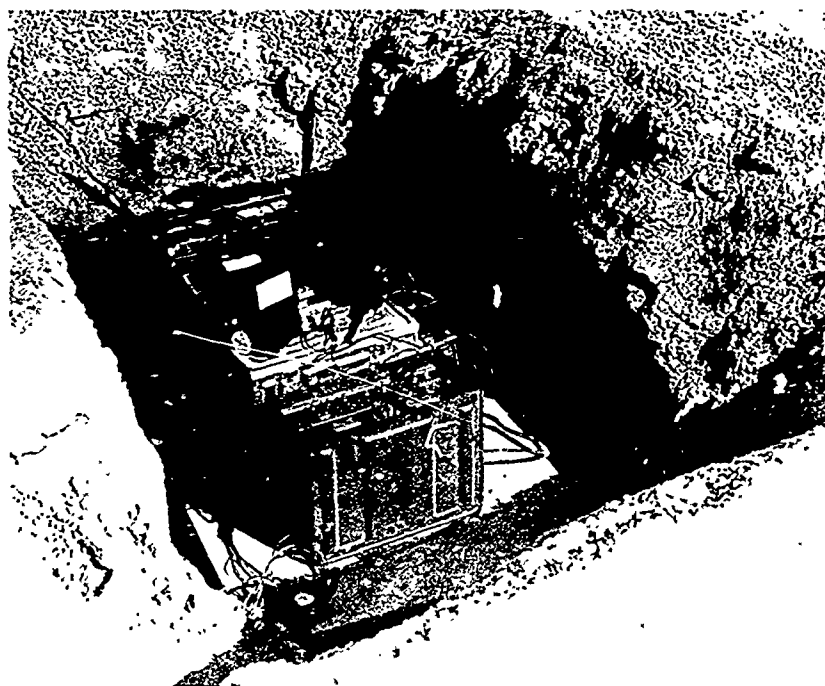

Fig. 2.12 Close-up of Coffin Hole

SECRET

RESTRICTED DATA
EXEMPT FROM GDS ACT 1946

~~SECRET~~

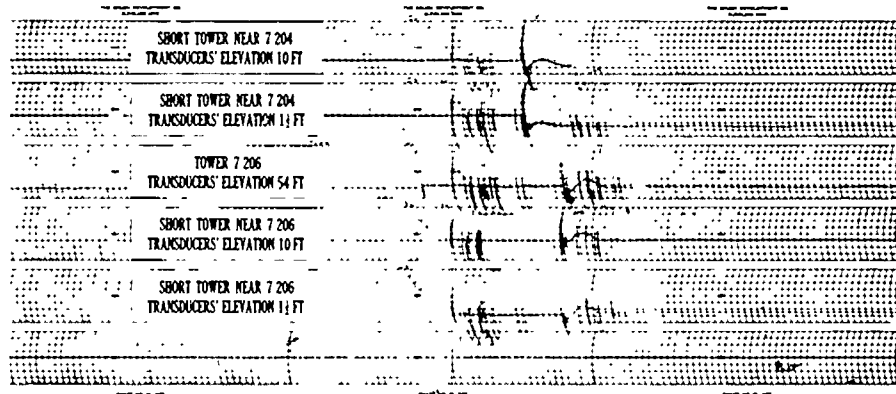
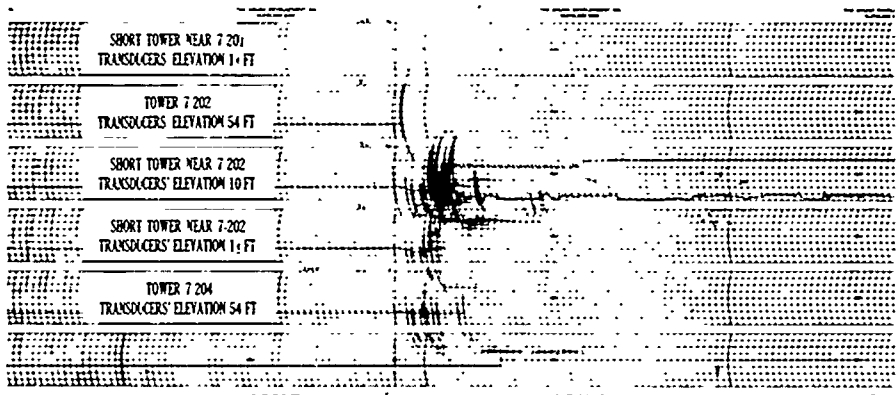
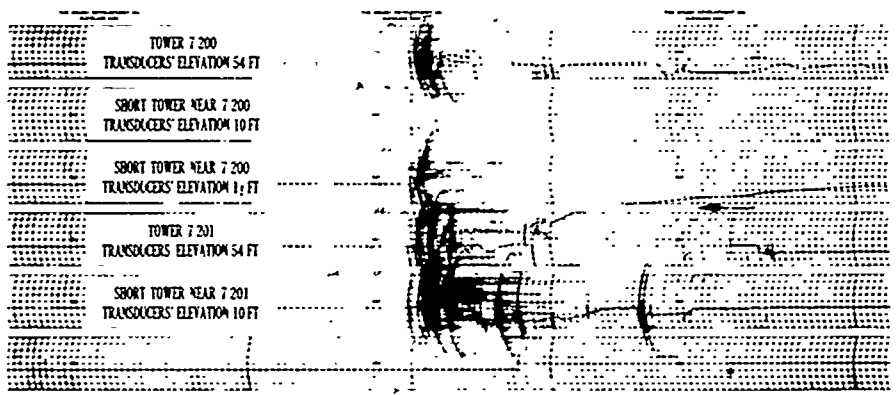

Fig. 2.13 Velocity Vs Time Field Records Tumbler 2. Increasing velocity downward. Increasing time to the right.

~~SECRET~~

~~SECRET~~

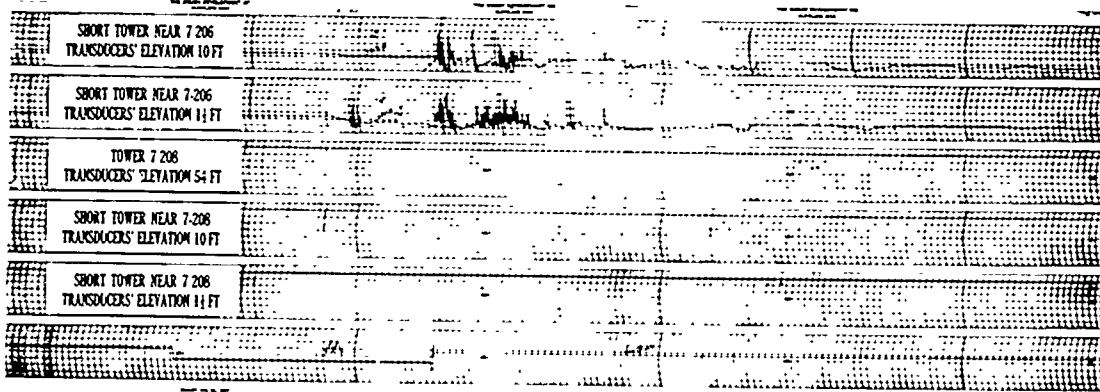
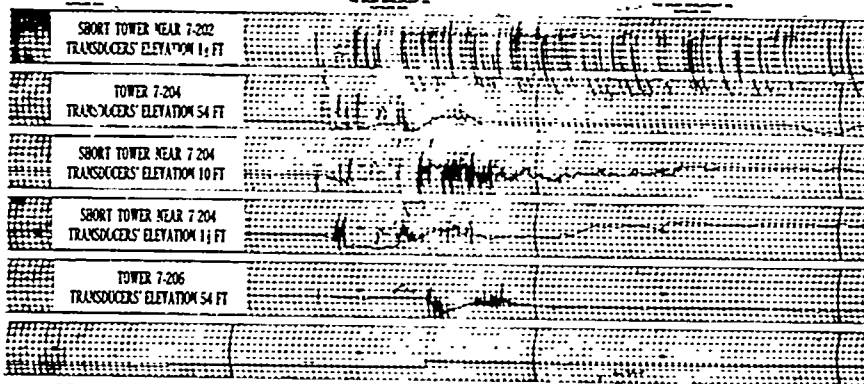
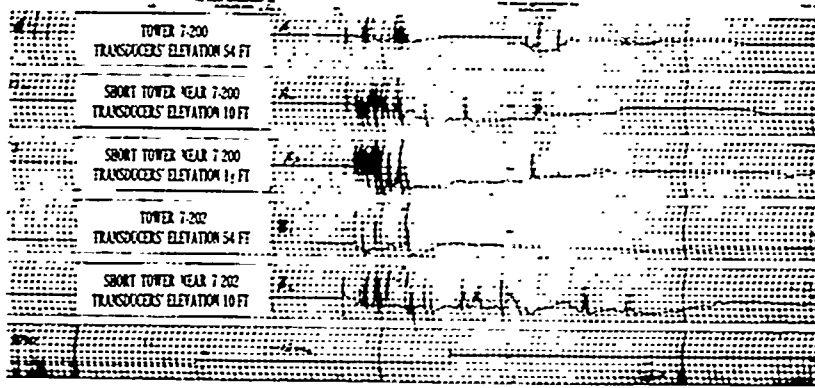

Fig. 2.14 Velocity Vs Time Field Records Tumbler 3. Increasing velocity downward. Increasing time to the right.

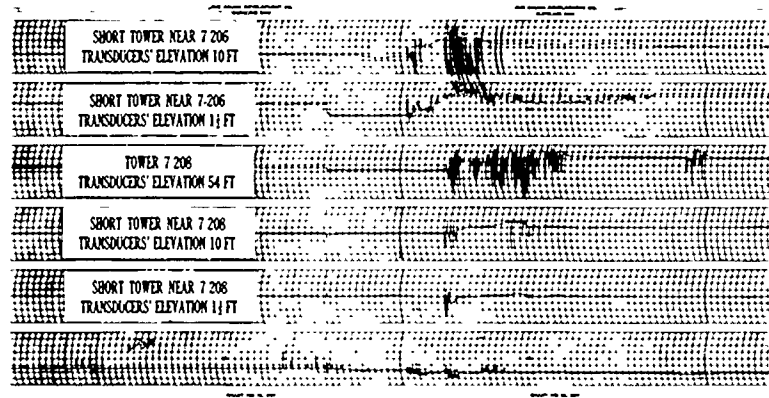
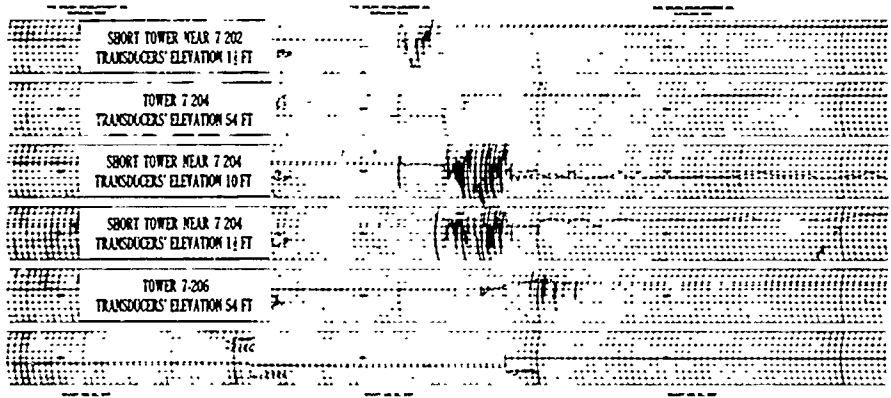
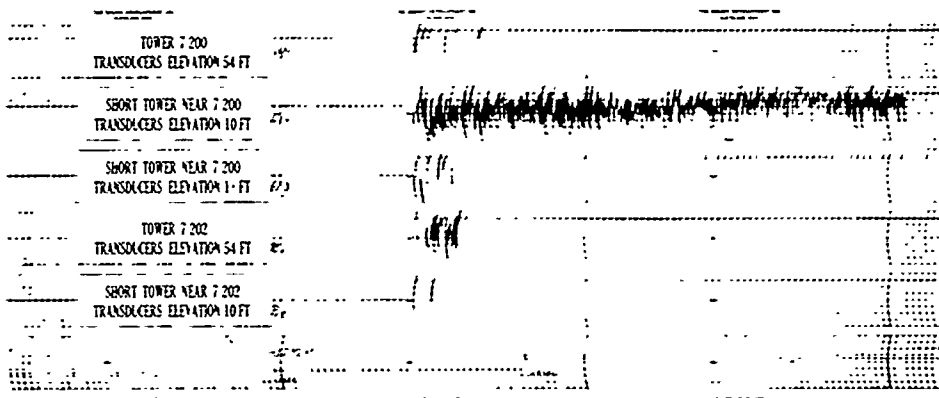

Fig. 2.15 Velocity Vs Time Field Records Tumbler 4. Increasing velocity downward. Increasing time to the right.

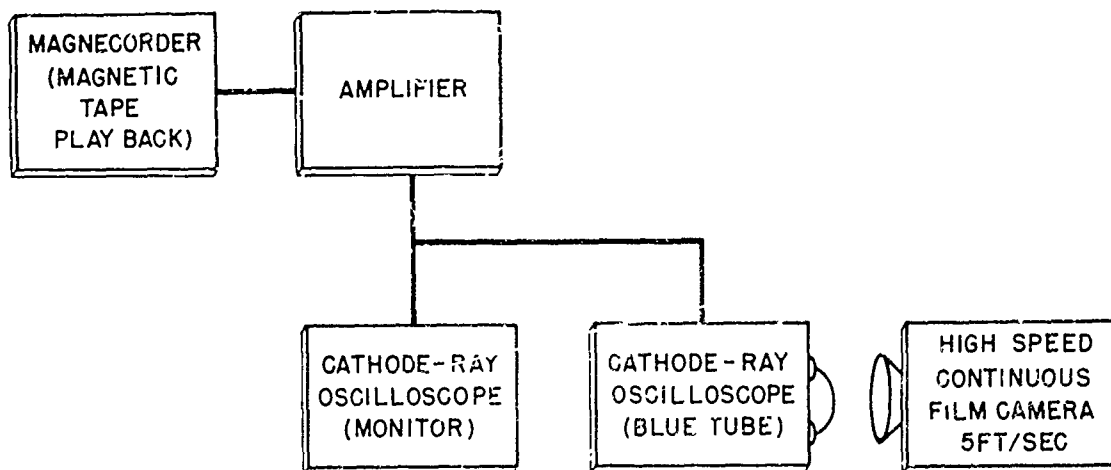

Fig. 2.16 Magnetic Tape to Film Record System

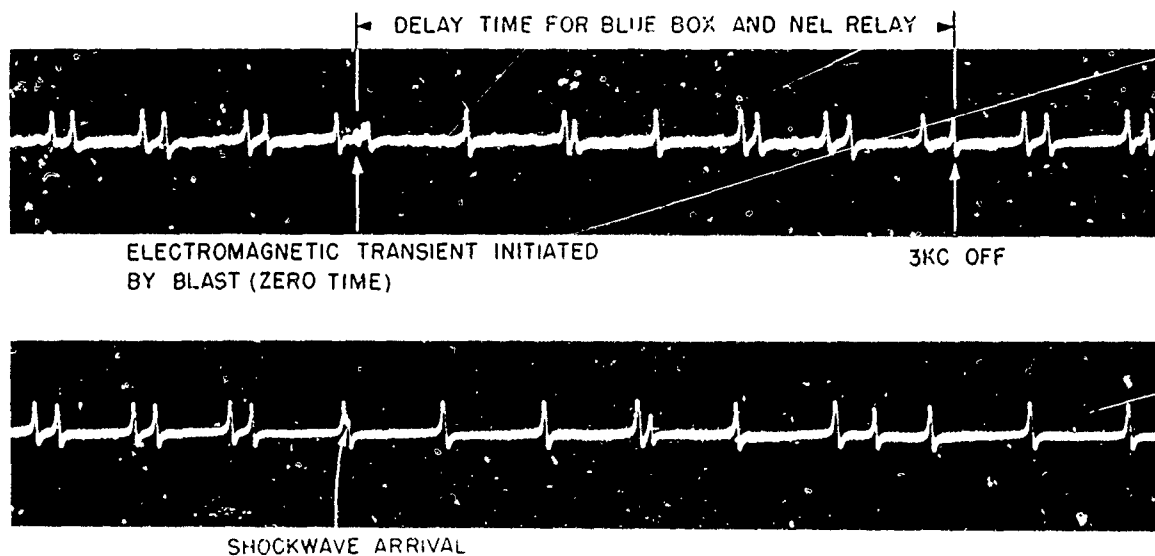

Fig. 2.17 Reference and Acoustic Spikes

~~SECRET~~

~~UNCLASSIFIED DATA~~

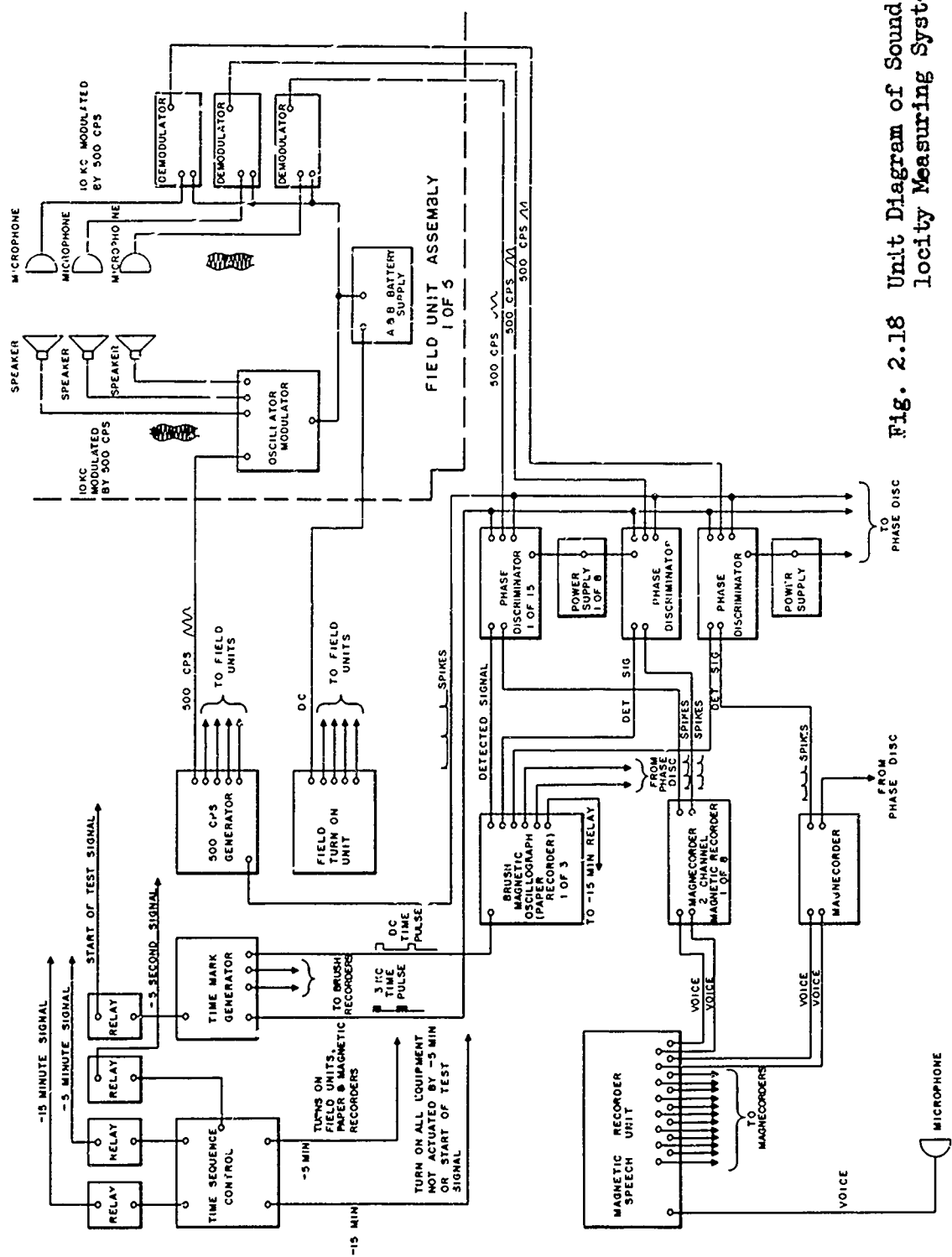

Fig. 2.18 Unit Diagram of Sound Velocity Measuring System

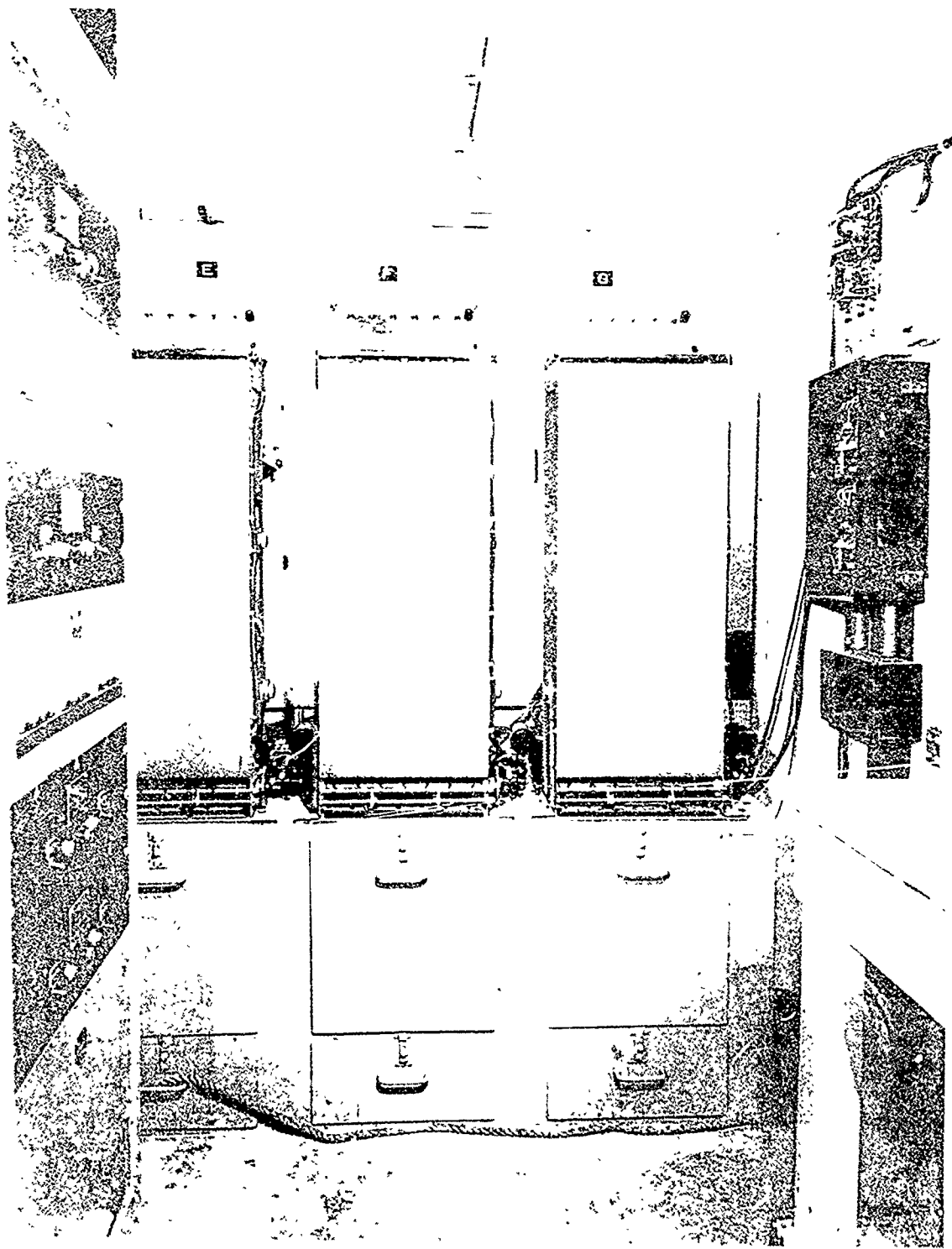

Fig. 2.19 NEL Paper Recorders

[REDACTED]

[REDACTED]

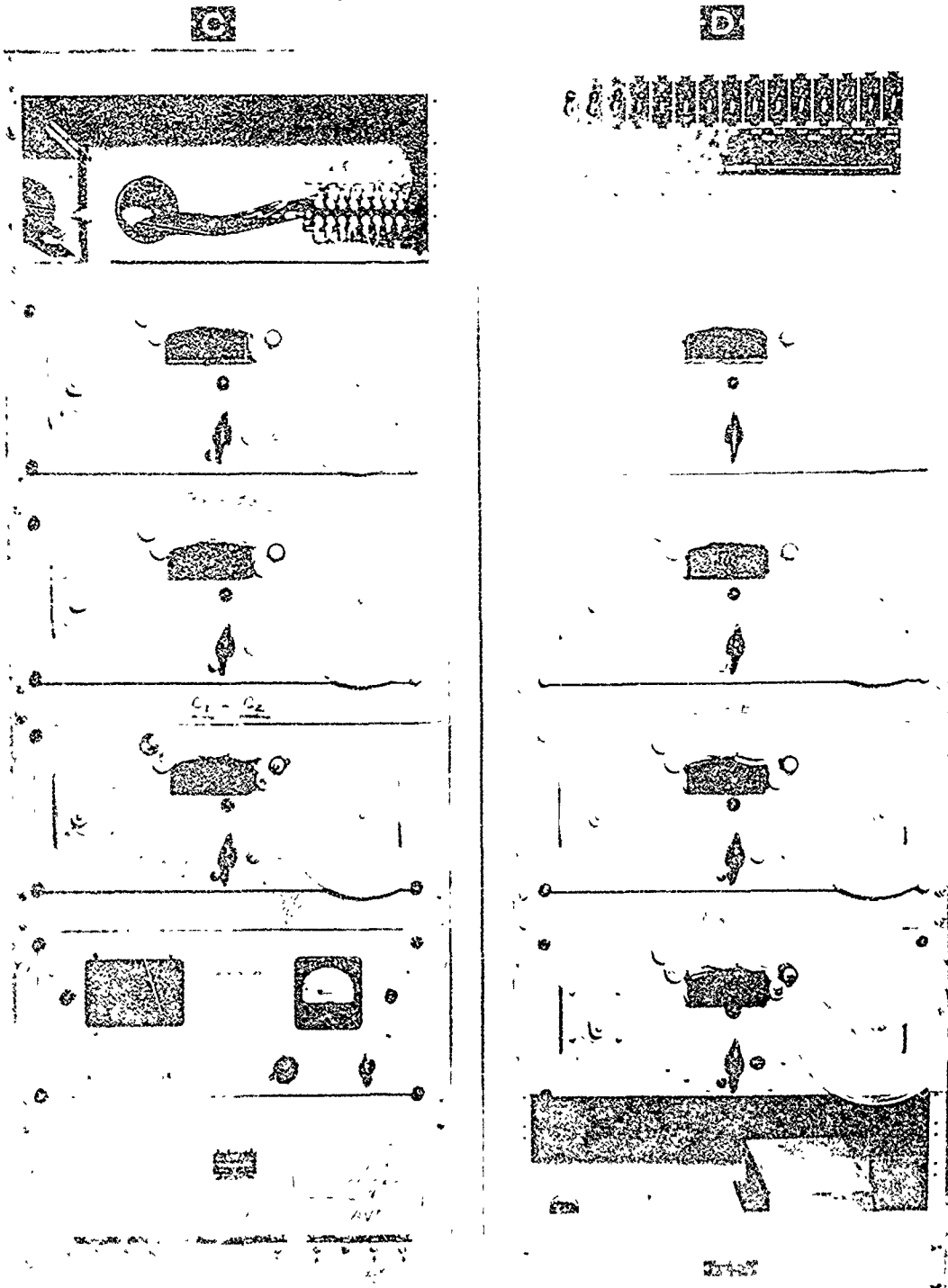

Fig. 2.20 NEL Magnetic Recorder Panel

RESULTS

The graphs of acoustic velocities in the air gaps between transducer diaphragms versus time after detonation are given for Tumbler 3 and 4 in figures 3.1 through 3.17. Figures 3.10 through 3.17 represent velocities in a period approximately 50 milliseconds before shock arrival and approximately 10 milliseconds afterwards. These are considered to be the most important NEL records as they show the acoustic velocity as "seen" by the shock wave as it reached the various measuring points. The time resolution in these graphs is 2 milliseconds. Figures 3.1 through 3.9 are records covering the interval from detonation to 4 seconds afterwards. These records have a minimum time resolution of 50 milliseconds, achieved by arbitrarily measuring velocity every 25 reference spikes. In the cases where an acoustic spike was missing at one of these points, say at time t_0 , the velocity information was taken at the nearest acoustic spike not greater than 16 milliseconds away. When no spike occurs within the 16 millisecond period, velocity is merely not plotted on the graph for time t_0 .

The shock wave arrival times depicted on all graphs are not actual receptions at the NEL transducers but rather are receptions at the nearby SRI blast gages as given in the Project 1.2 report, Air Pressure vs Time, WT-512.

The temperature scale on the right sides of figures 3.1 through 3.17 is a temperature equivalent to the acoustic velocity measured and does not represent the true temperature because of the effect of the wind (particle movement). If the wind velocity were zero, the temperature should be correct.

The maximum probable error in the Tumbler 3 velocity data is approximately 6 per cent. In the Tumbler 4 data this figure is as great as 12 per cent. These maxima occur only at times of greatest temperature and would not be as great as 2 per cent for ambient conditions. (See section 4.2 for details of accuracy.)

Appendix C contains the tabulated data from which figures 3.1 through 3.9 were plotted. Appendix D contains the tabulated data from which figures 3.10 through 3.17 were plotted.

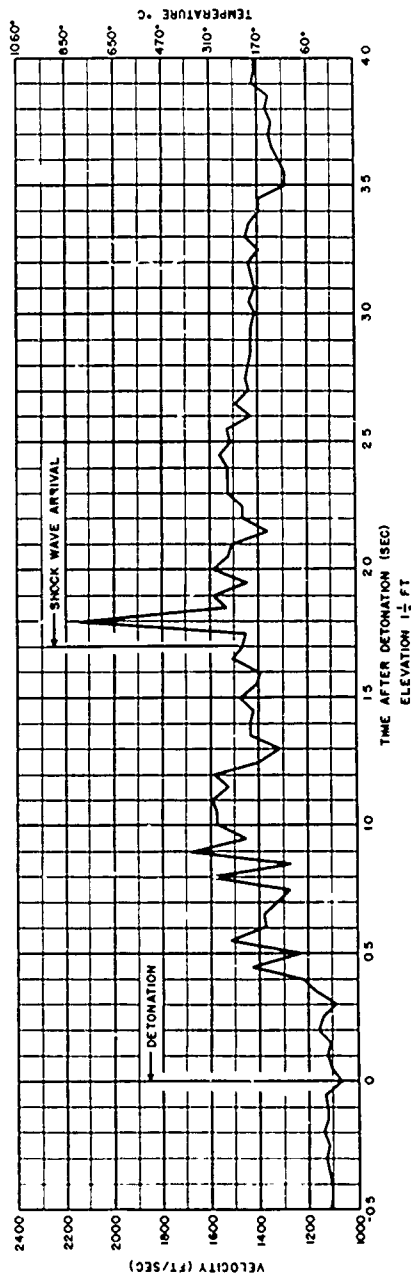
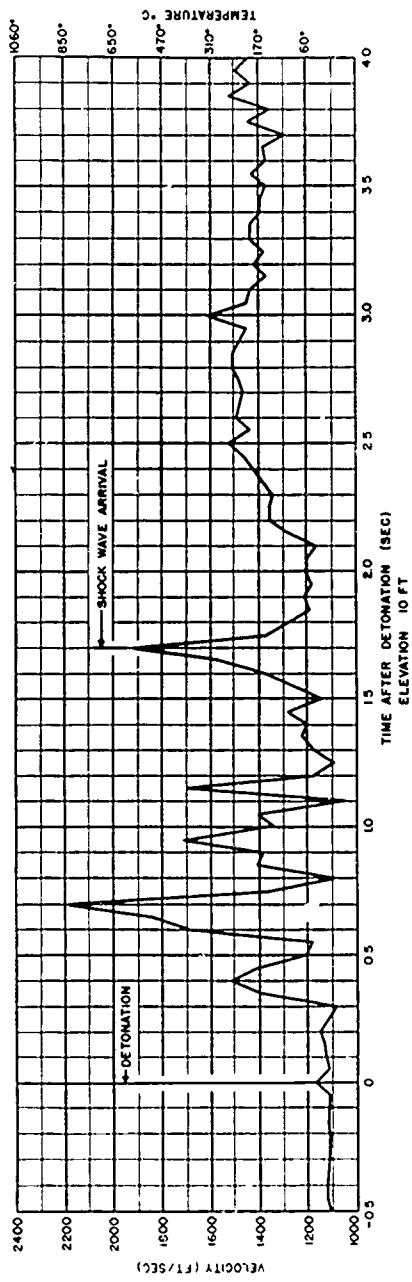
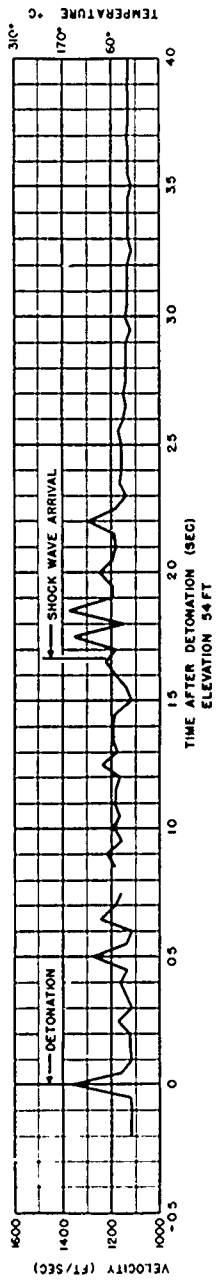

Fig. 3.1 Acoustic Velocity Vs Time Curves Tumbler 3, Tower 200

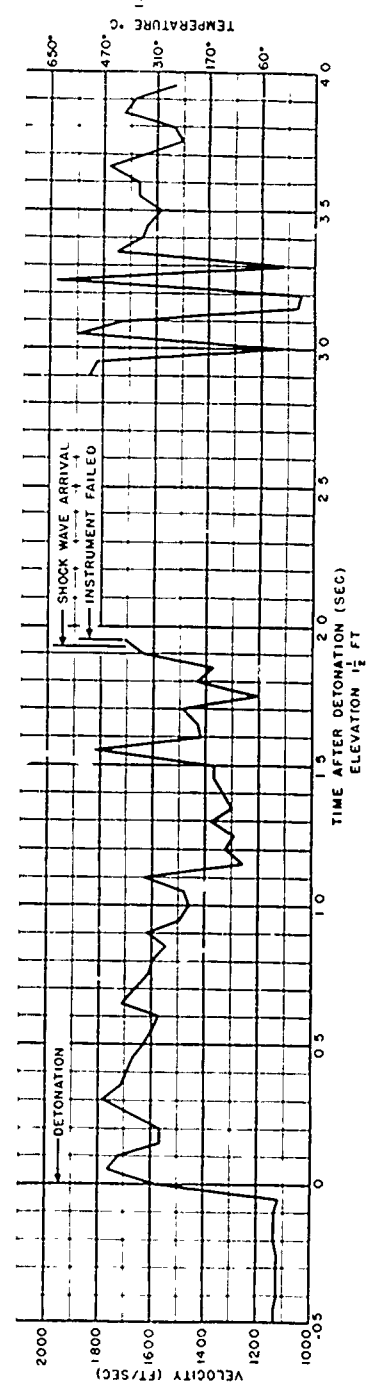
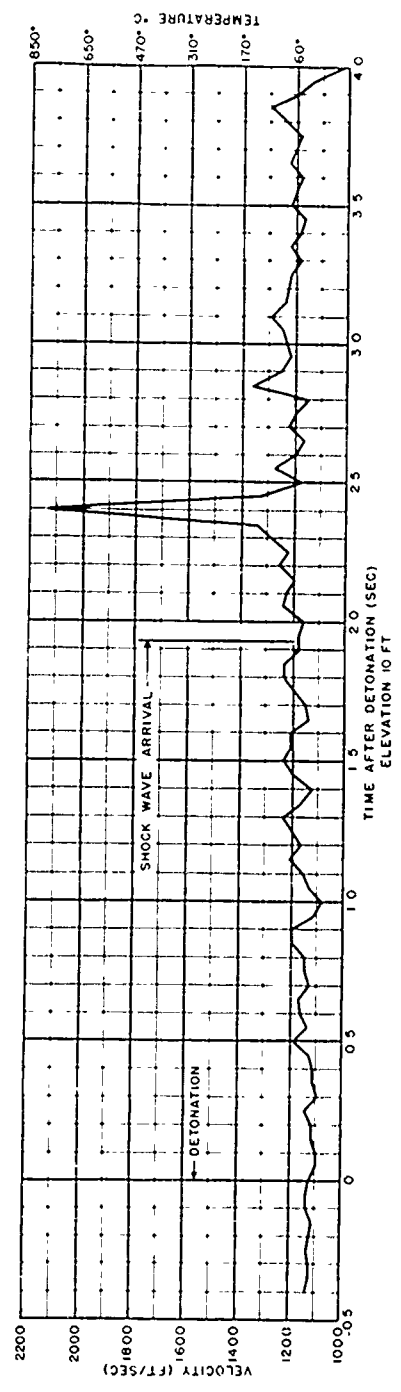
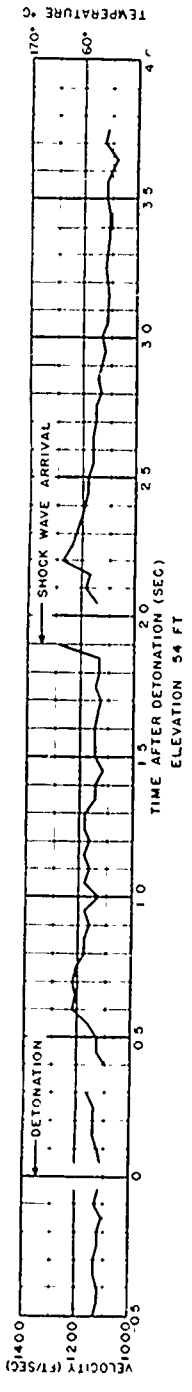

Fig. 3.2 Acoustic Velocity Vs Time Curves Tumbler 3, Tower 202

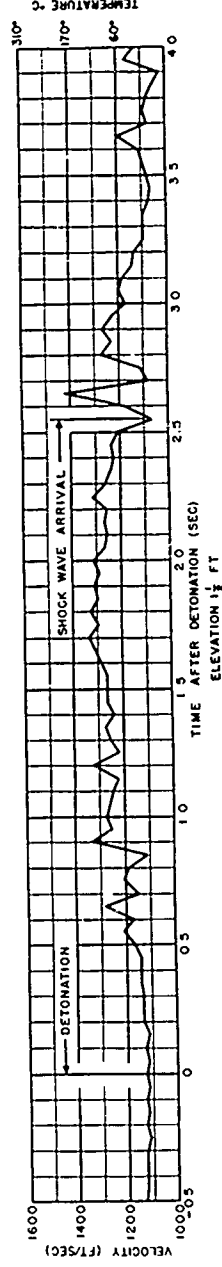
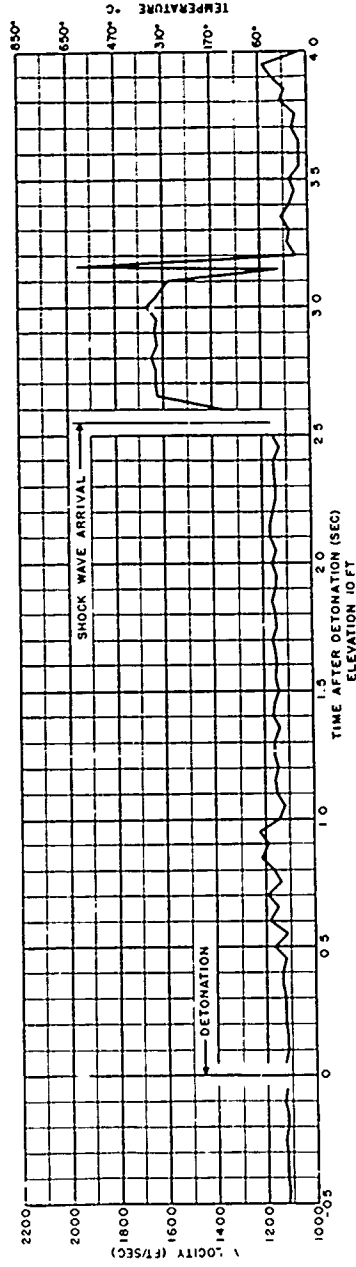
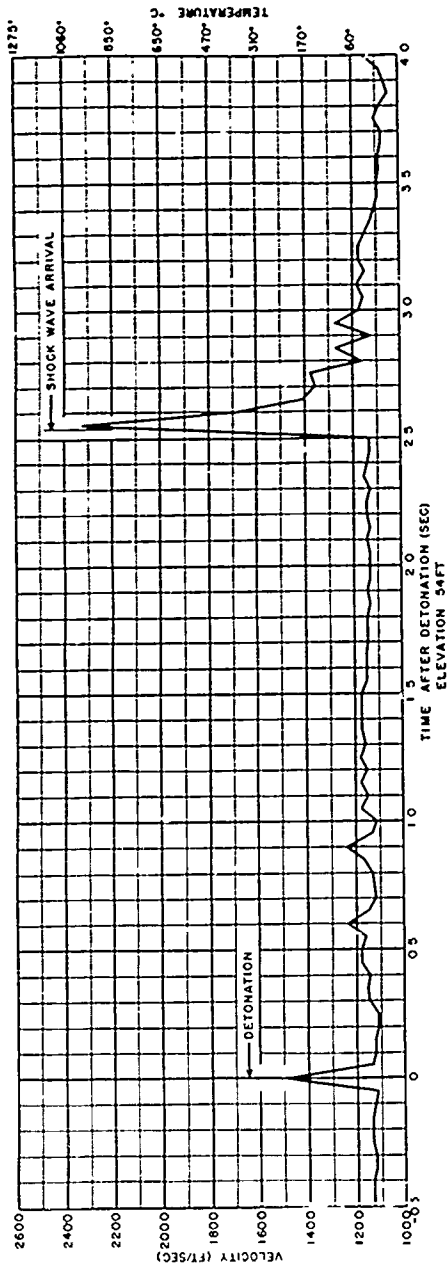

Fig. 3.3 Acoustic Velocity Vs Time Curves Tumbler 3, Tower 204

~~RESTRICTED DATA~~

~~SECRET~~

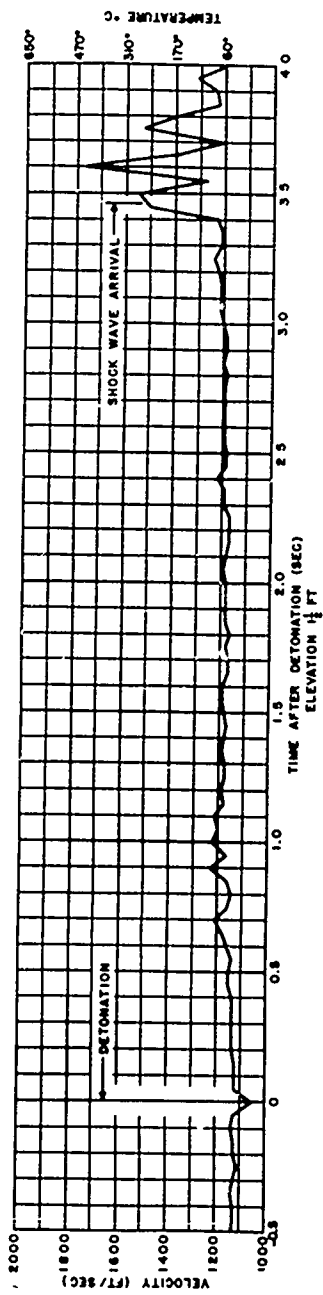
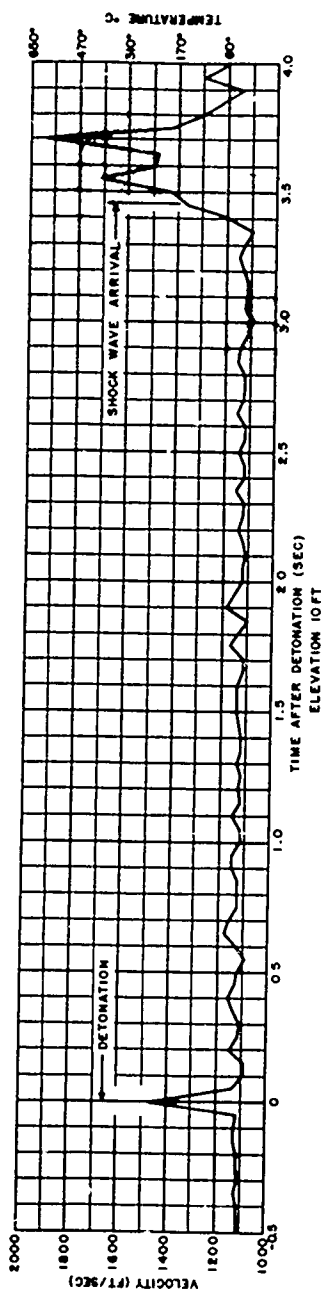
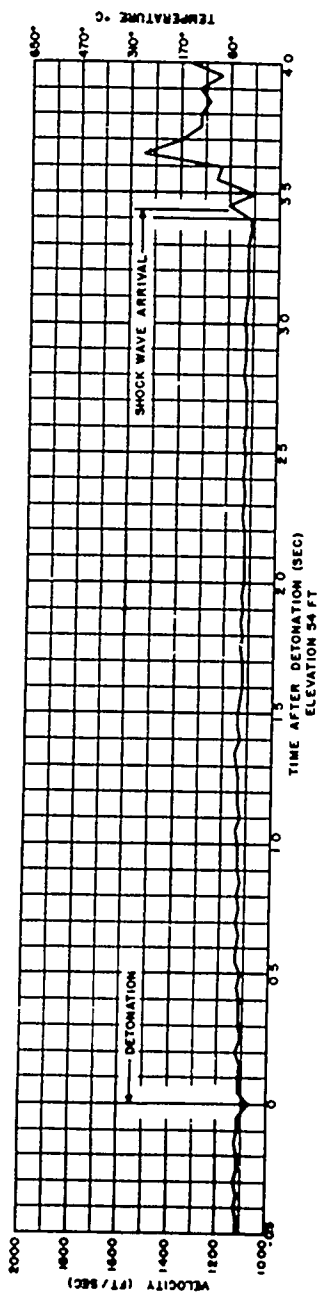

Fig. 3.4 Acoustic Velocity Vs Time Curves Tumbler 3, Tower 206

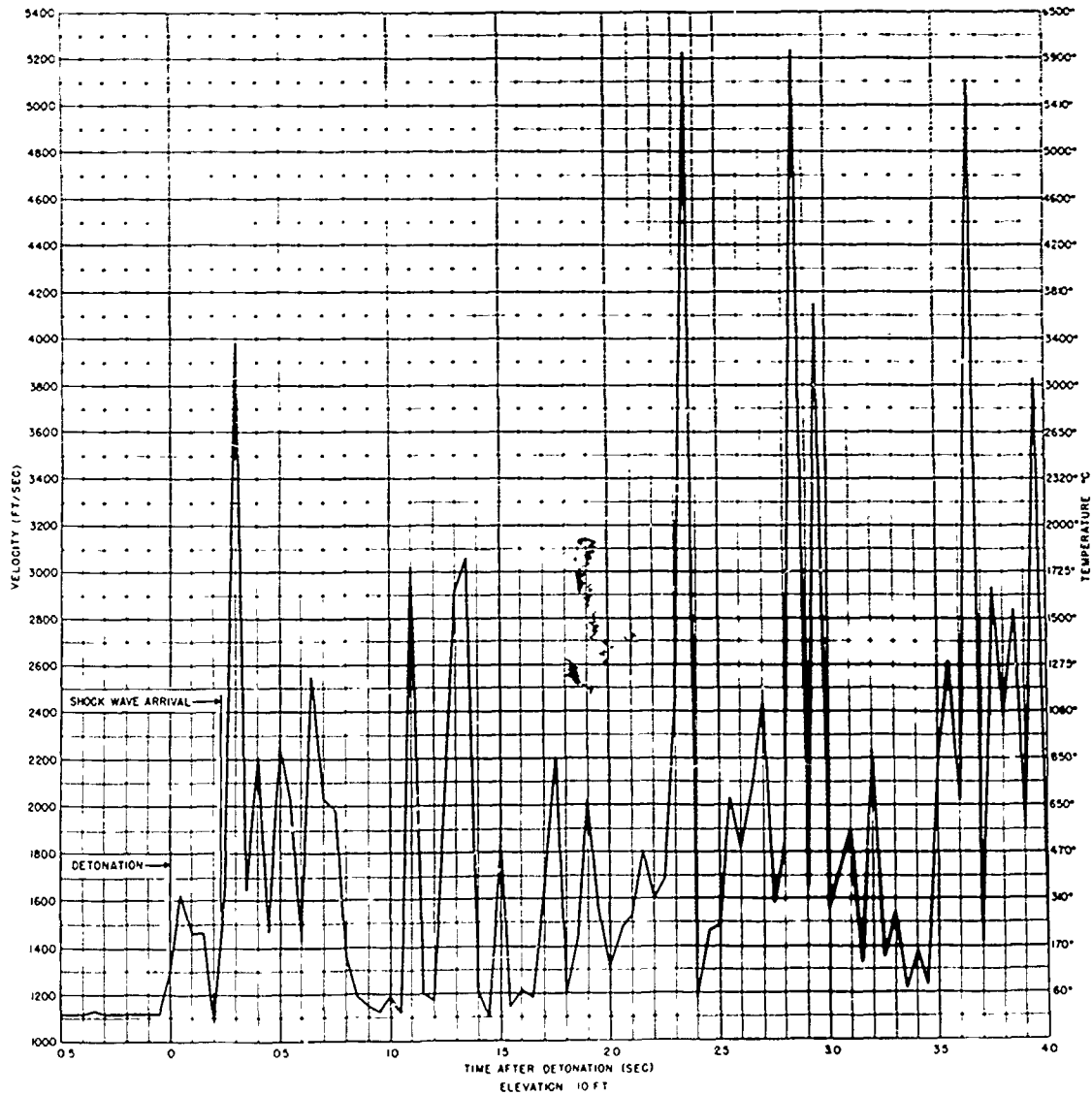
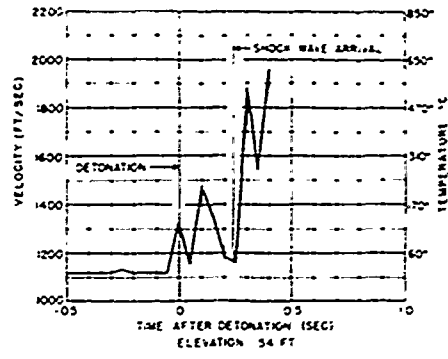
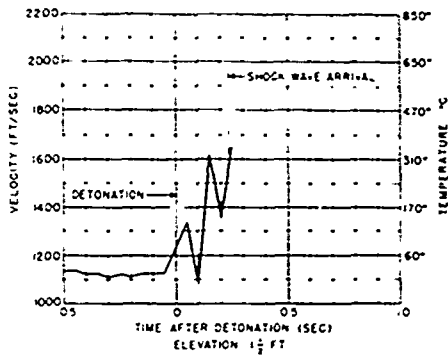

Fig. 3.5 Acoustic Velocity Vs Time Curves Tumbler 4, Tower 200

~~SECRET~~

~~SECRET~~

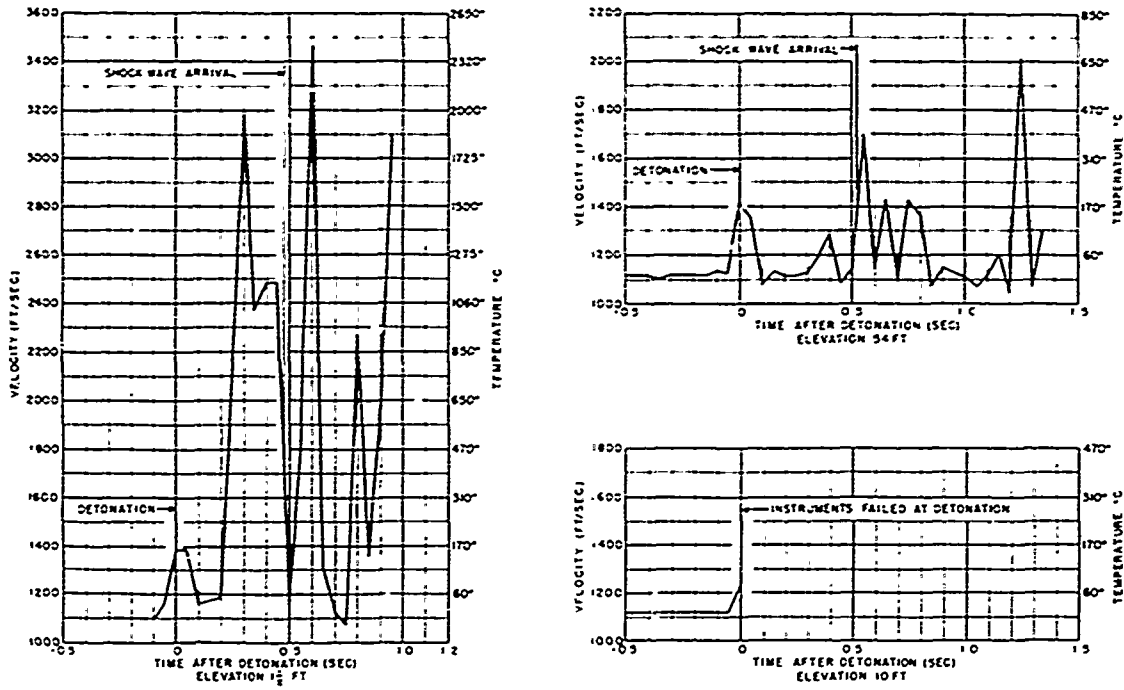

Fig. 3.6 Acoustic Velocity Vs Time Curves Tumbler 4, Tower 202

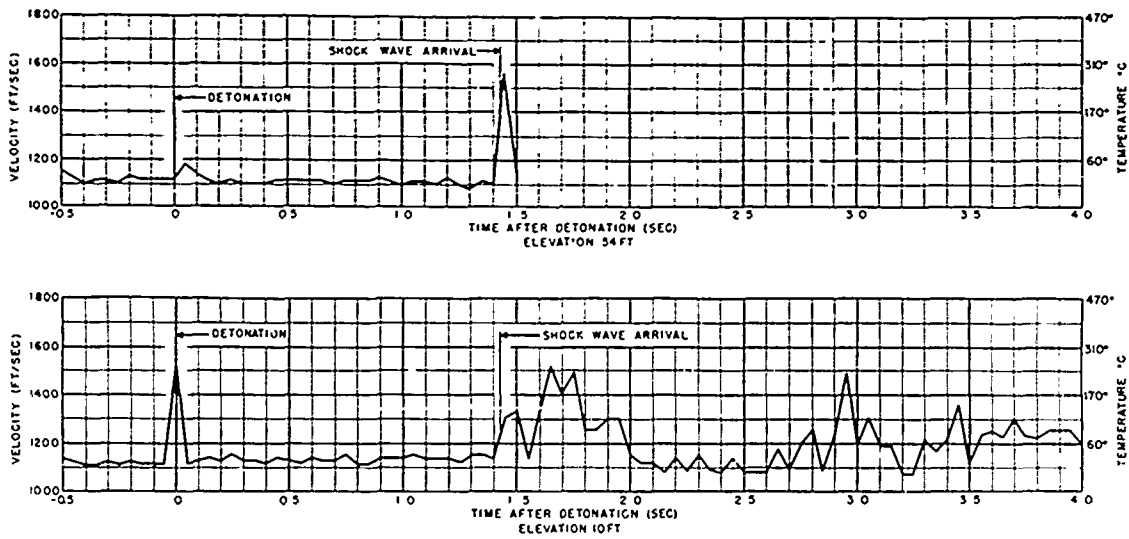
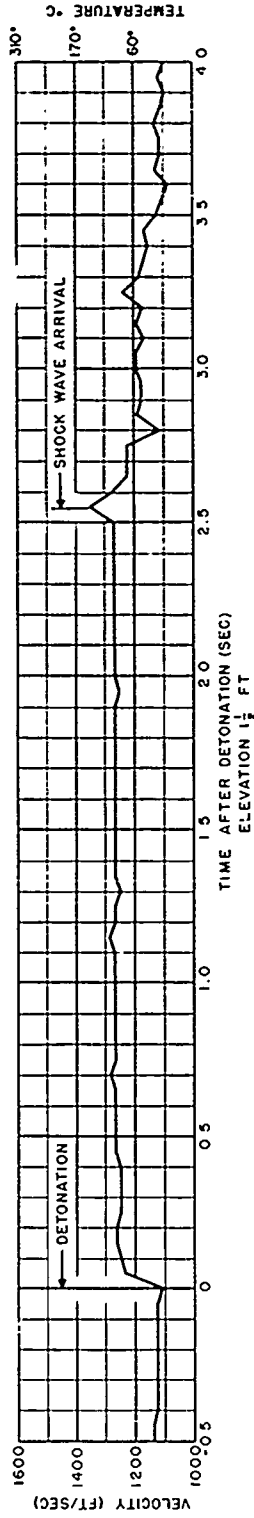
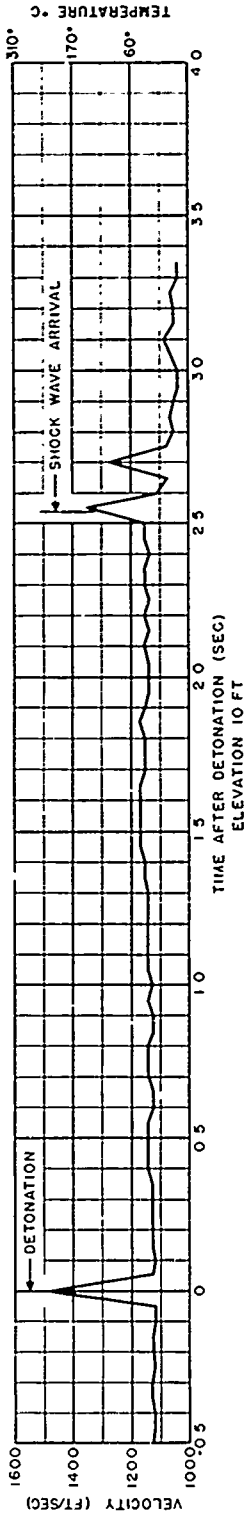
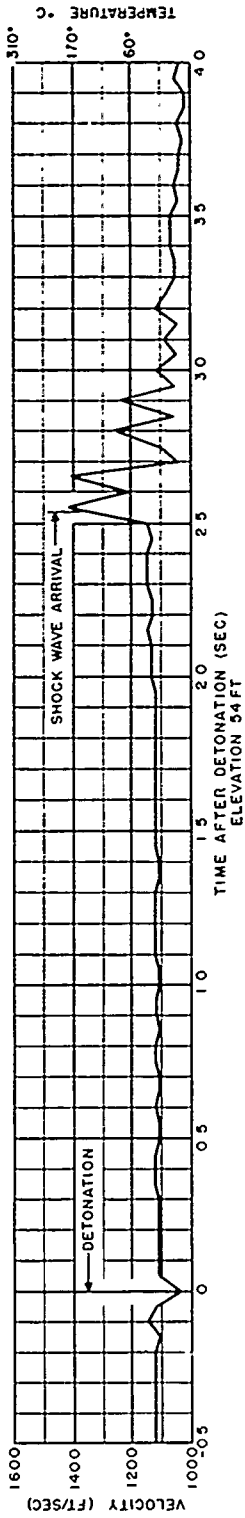

Fig. 3.7 Acoustic Velocity Vs Time Curves Tumbler 4, Tower 204



TEMPERATURE °C

TEMPERATURE °C

TEMPERATURE °C

Fig. 3.8 Acoustic Velocity Vs Time Curves Tumbler 4, Tower 206

SECRET

SECRET

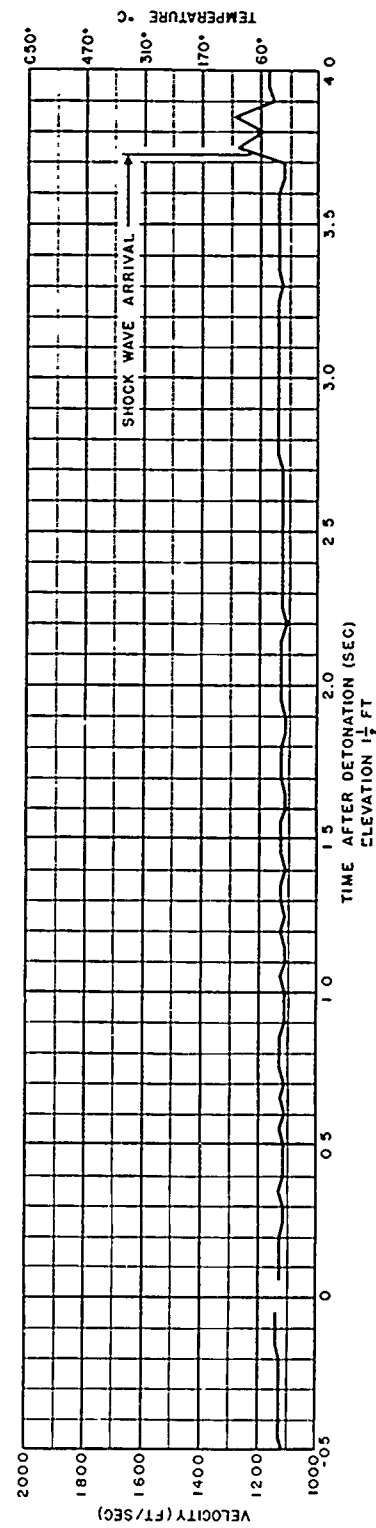
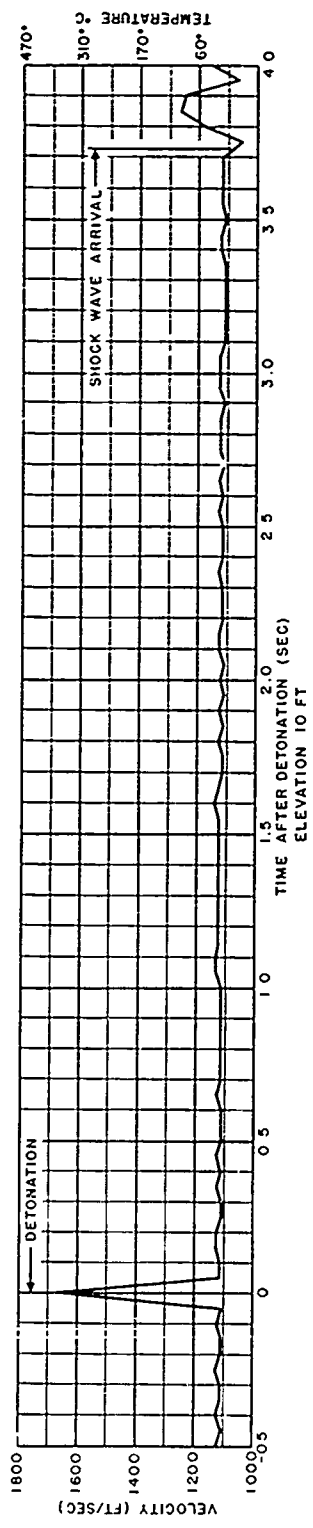
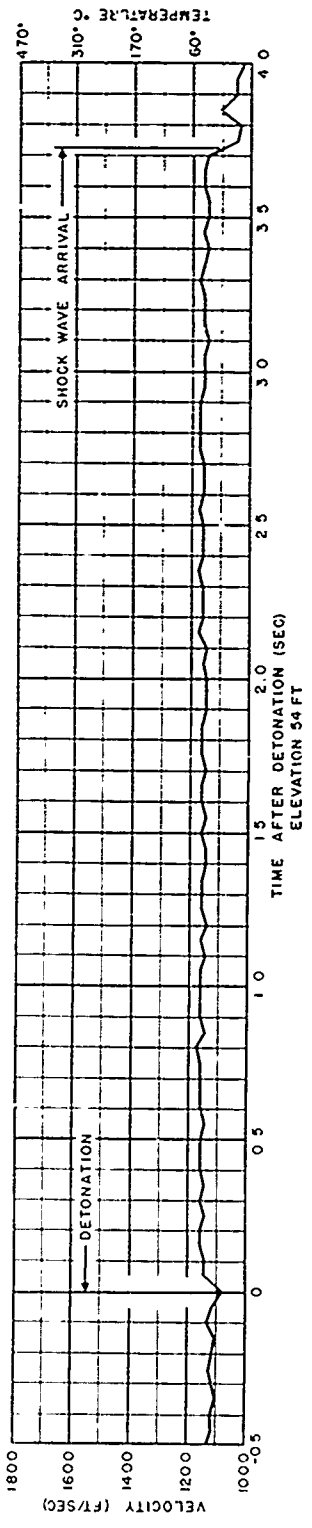

Fig. 3.9 Acoustic Velocity Vs Time Curves Tumbler 4, Tower 208

ATOMIC ENERGY

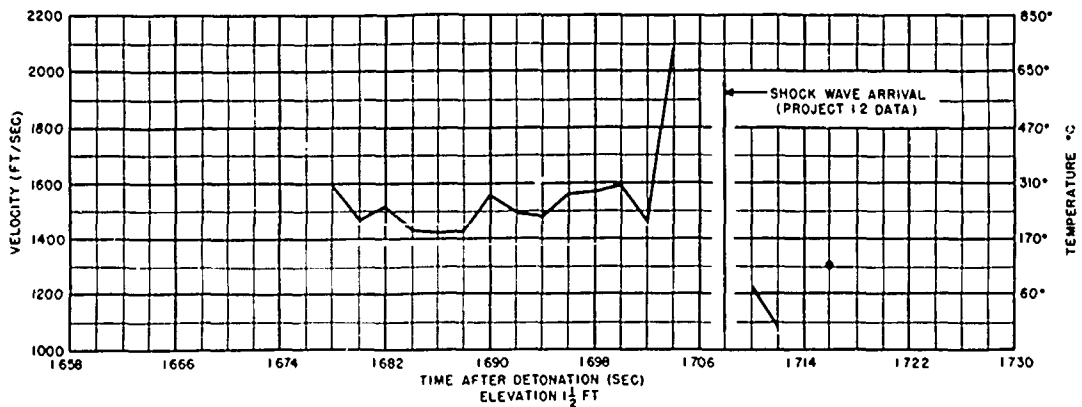
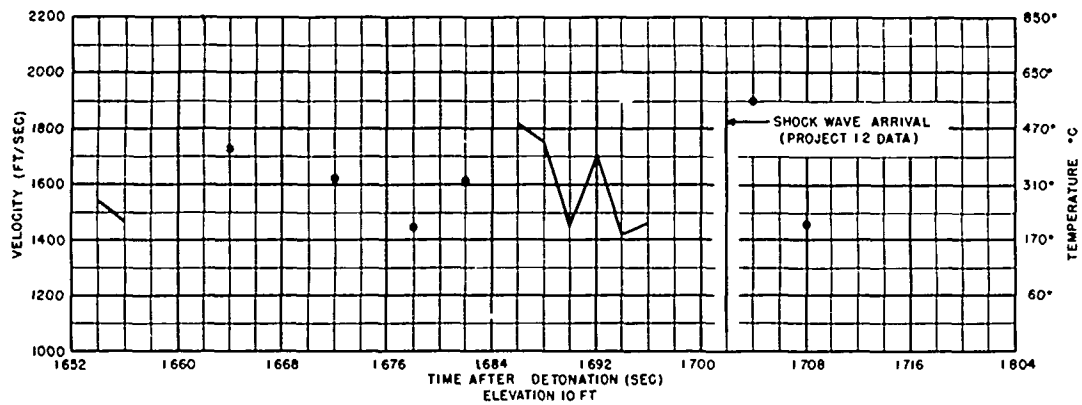
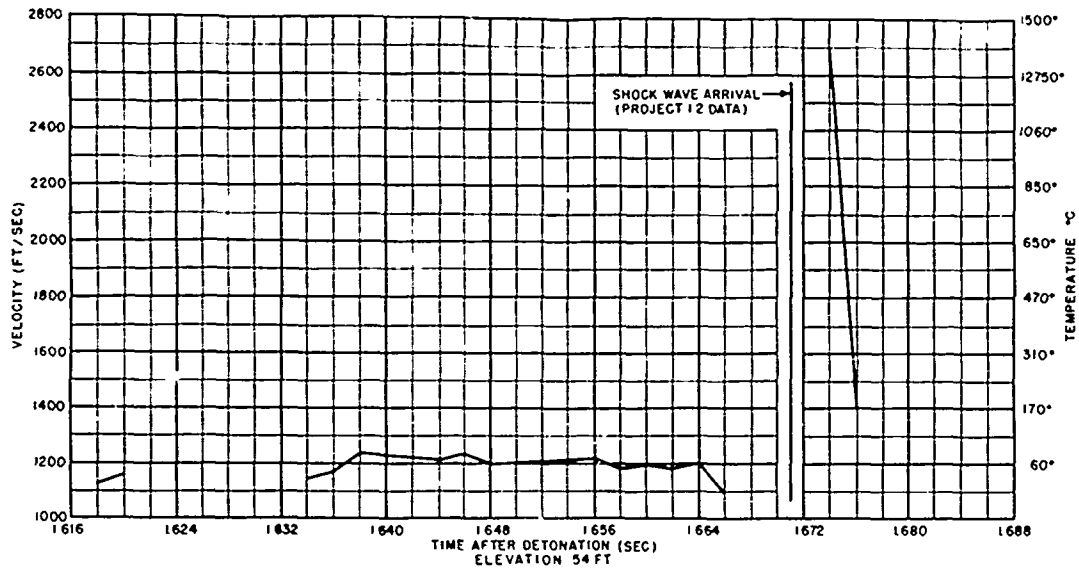

Fig. 3.10 Acoustic Velocity Vs Time Curves Tumbler 3, Tower 200

RECORDED DATA
A

SECRET

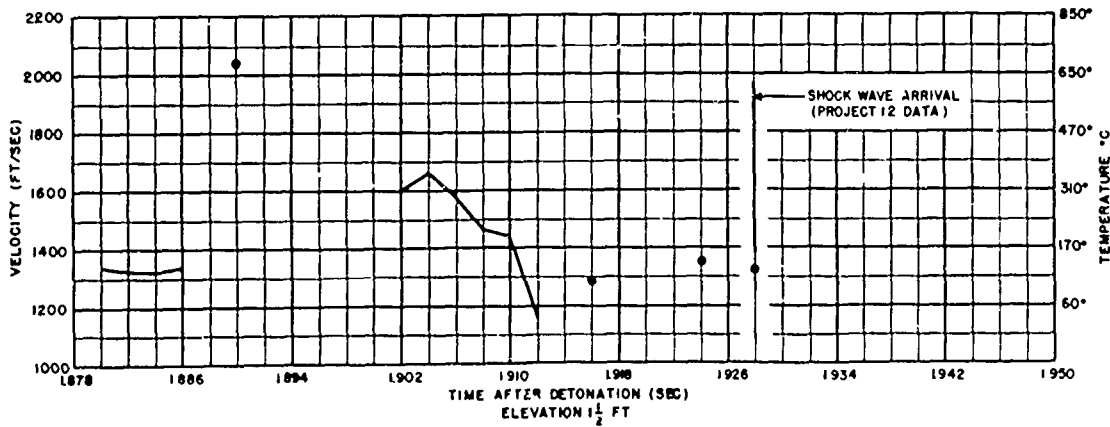
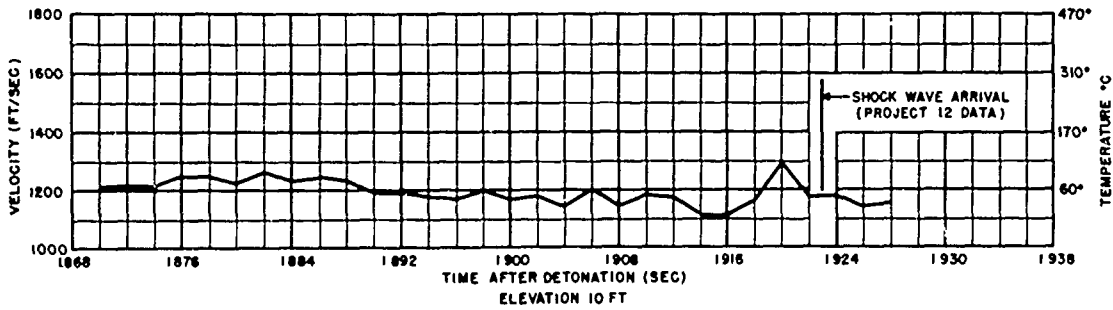
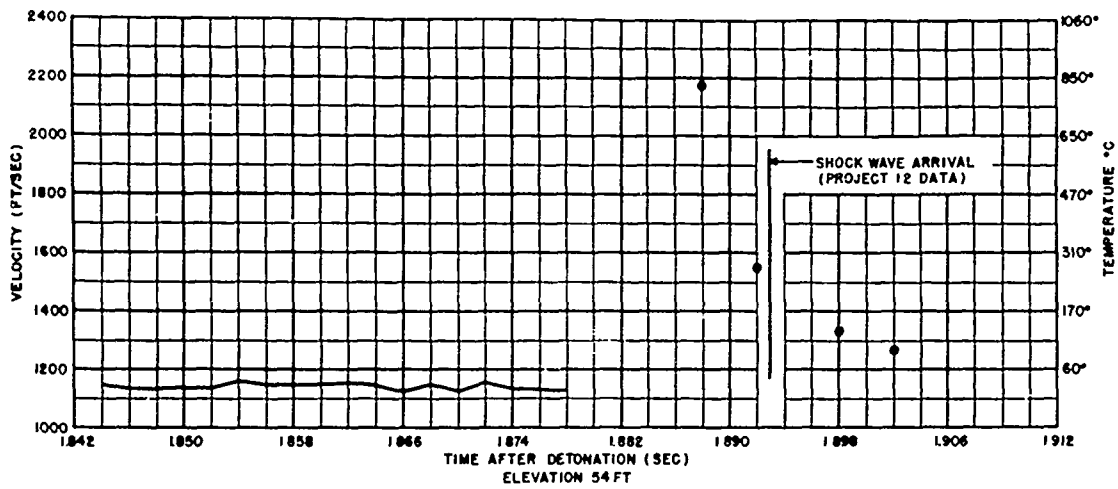

Fig. 3.11 Acoustic Velocity Vs Time Curves Tumbler 3, Tower 202

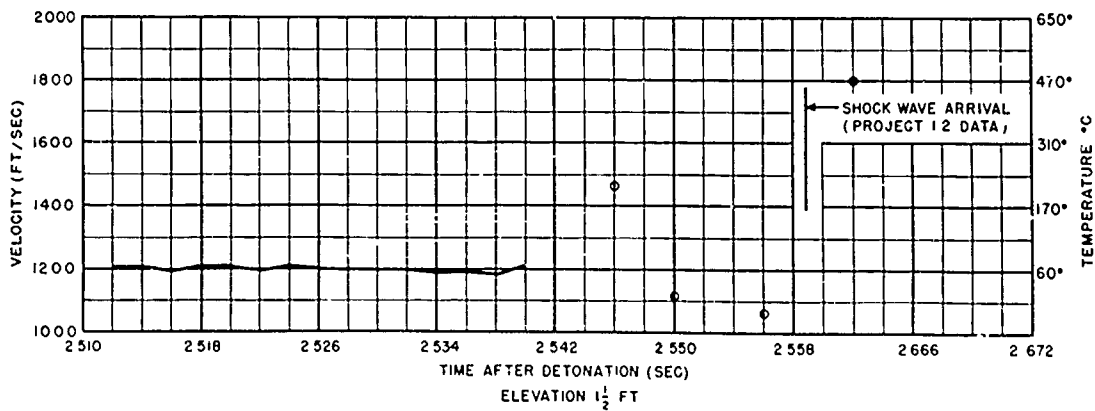
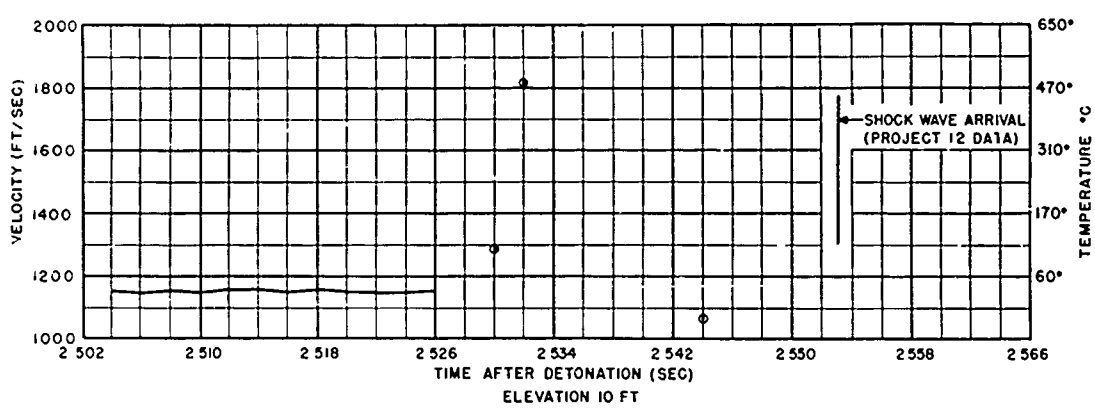
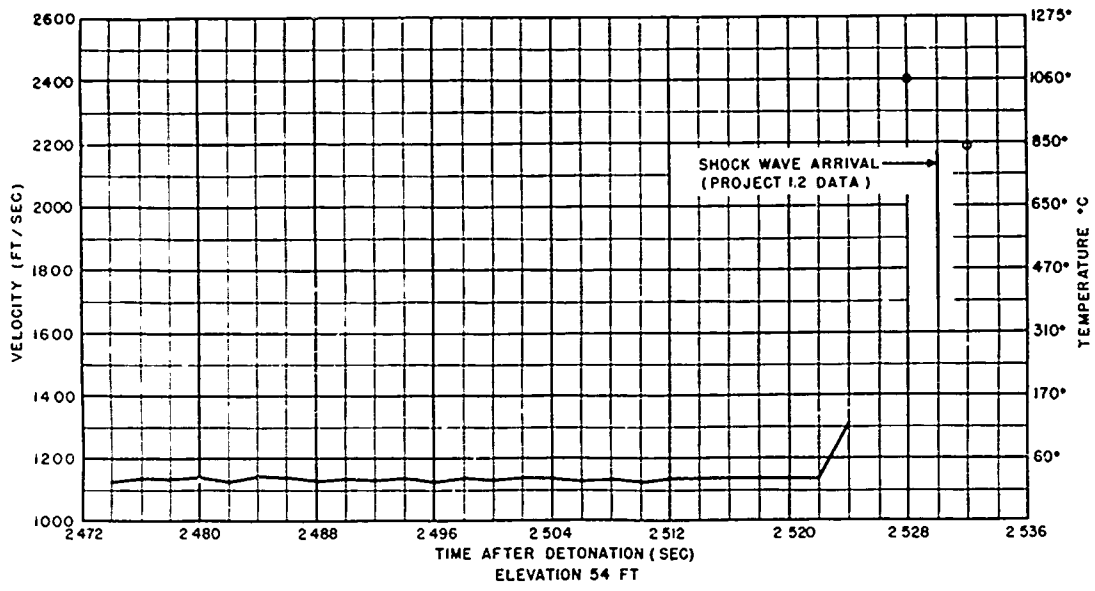

Fig. 3.12 Acoustic Velocity Vs Time Curves Tumbler 3, Tower 204

~~SECRET~~

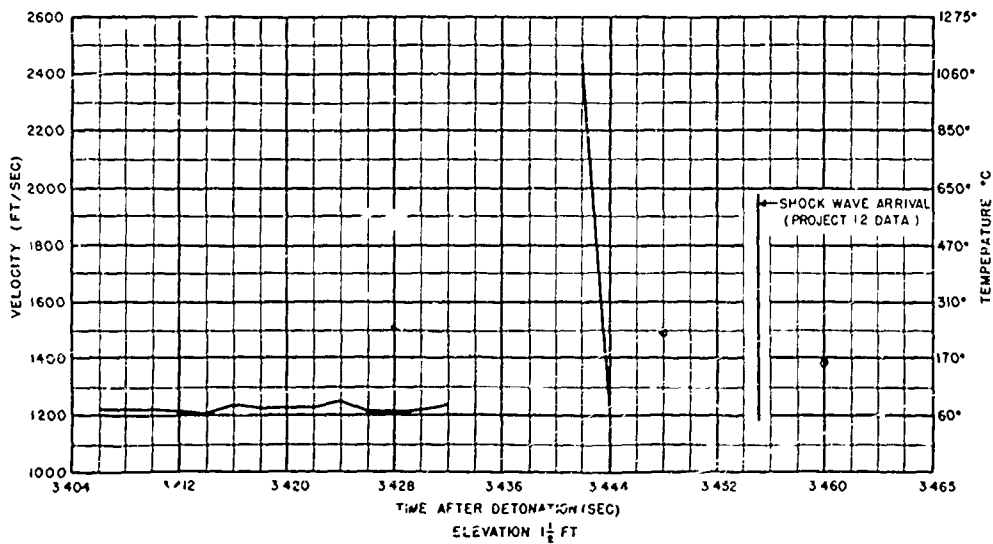
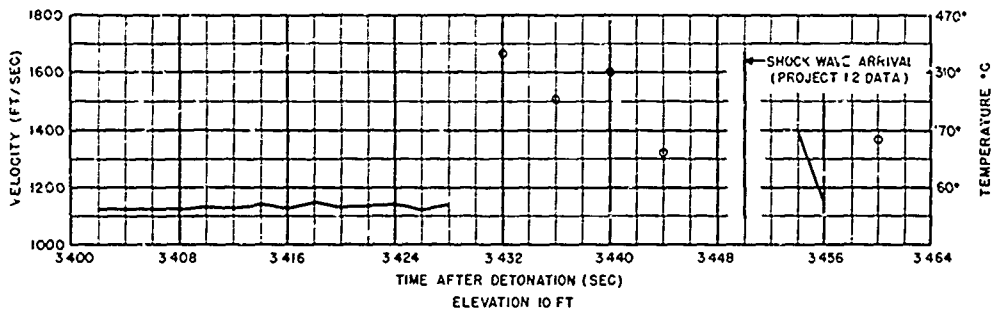
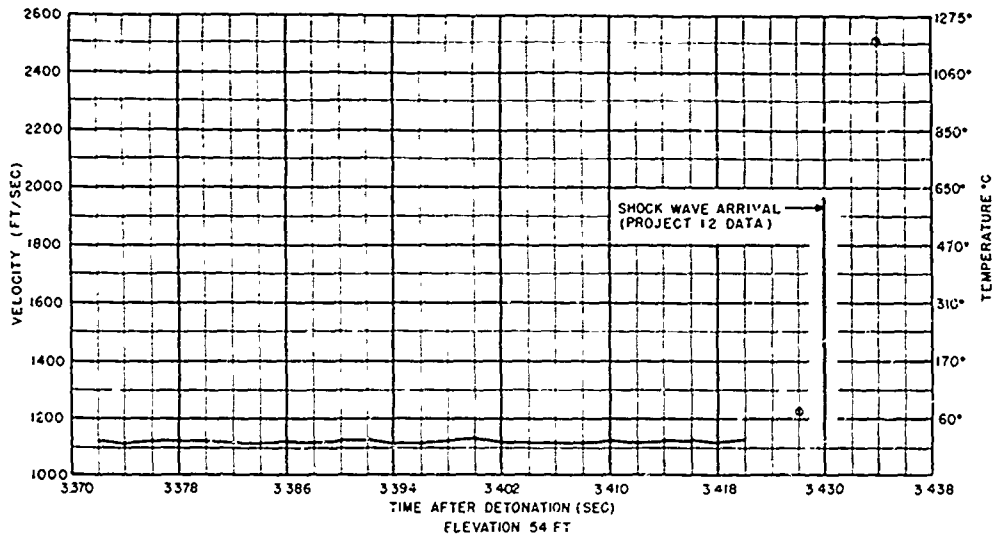

Fig. 3.13 Acoustic Velocity Vs Time Curves Tumbler 3, Tower 206

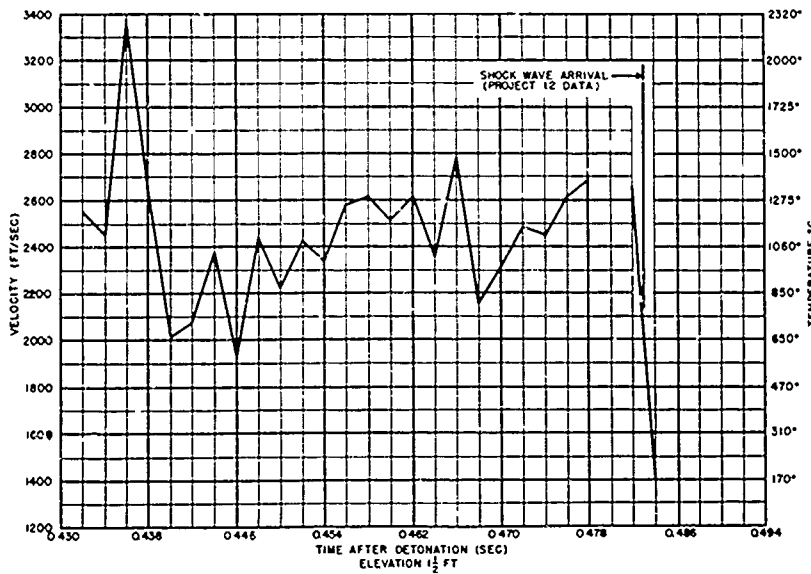
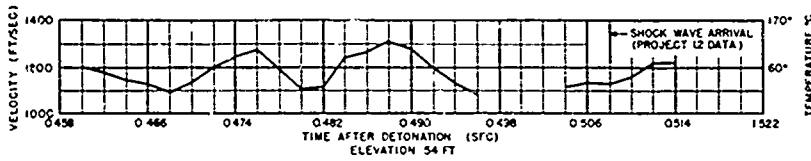

Fig. 3.14 Acoustic Velocity Vs Time Curves Tumbler 4, Tower 202

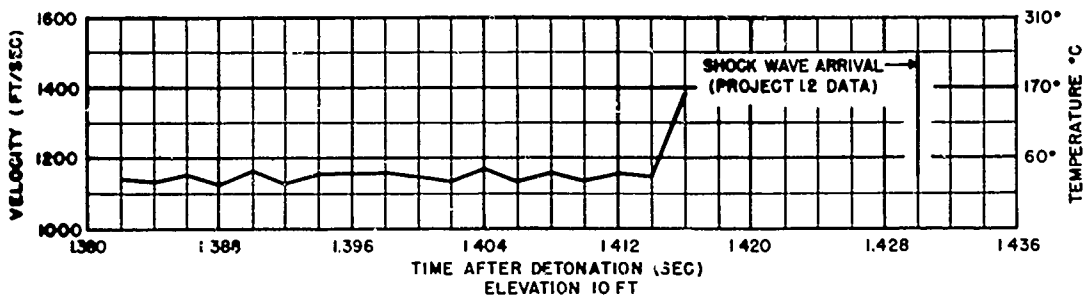
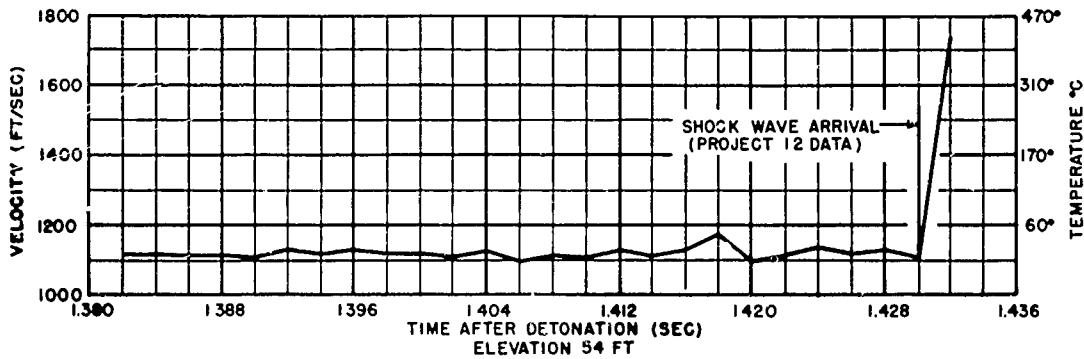

Fig. 3.15 Acoustic Velocity Vs Time Curves Tumbler 4, Tower 204

~~SECRET~~

~~SECRET~~

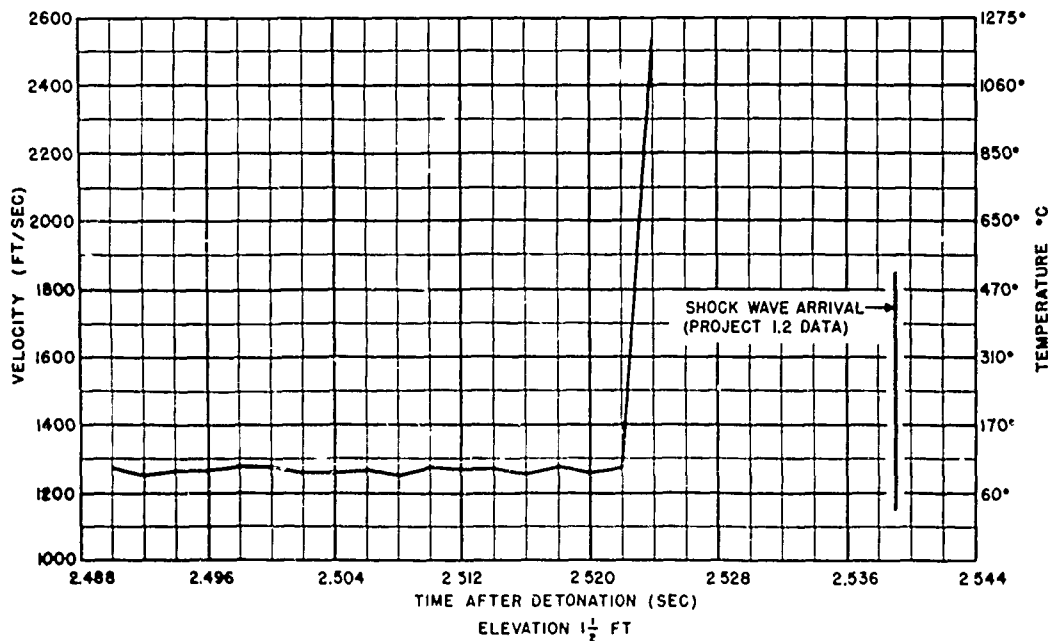
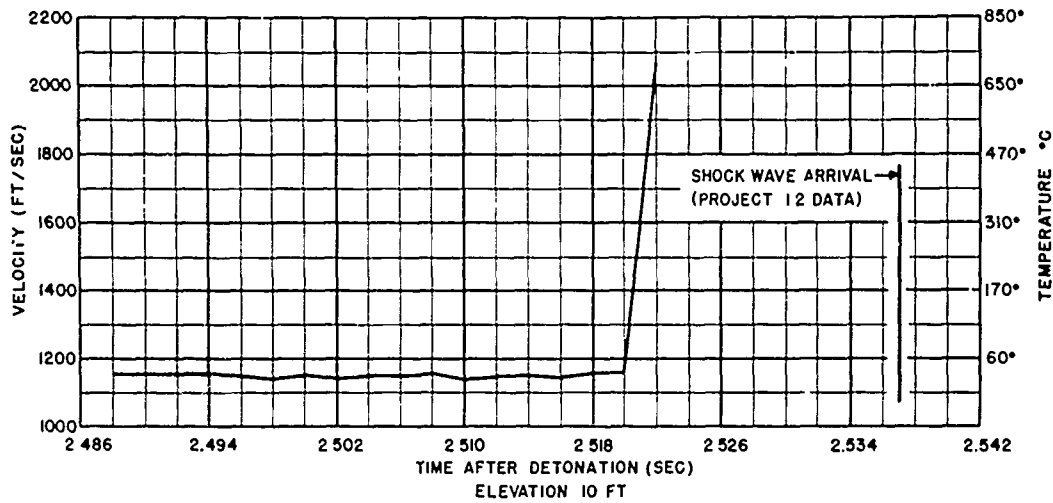
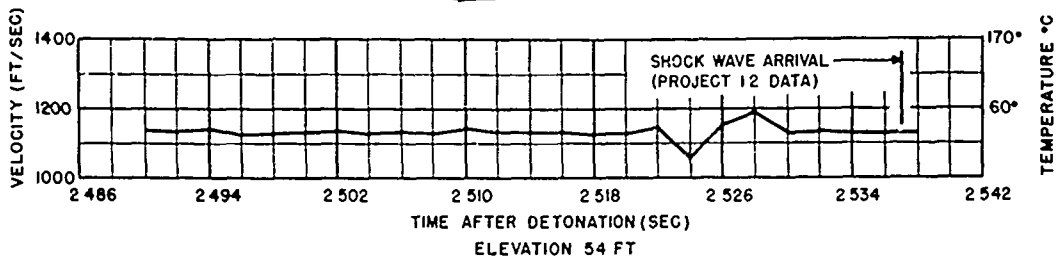

Fig. 3.16 Acoustic Velocity Vs Time Curves Tumbler 4, Tower 206

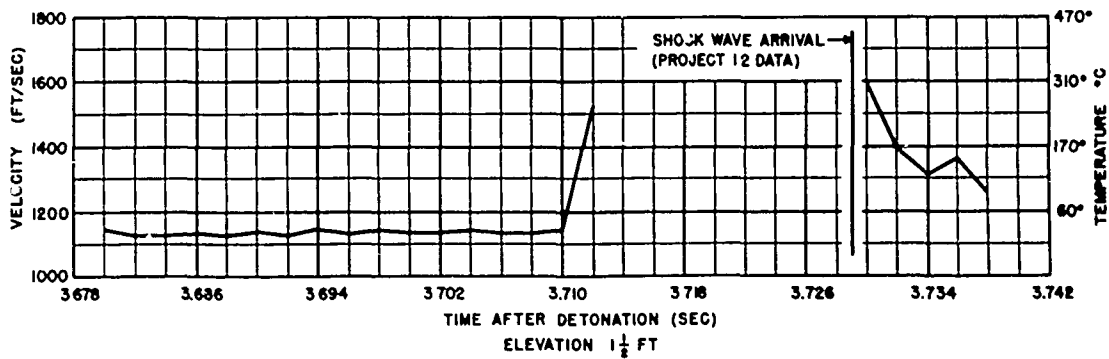
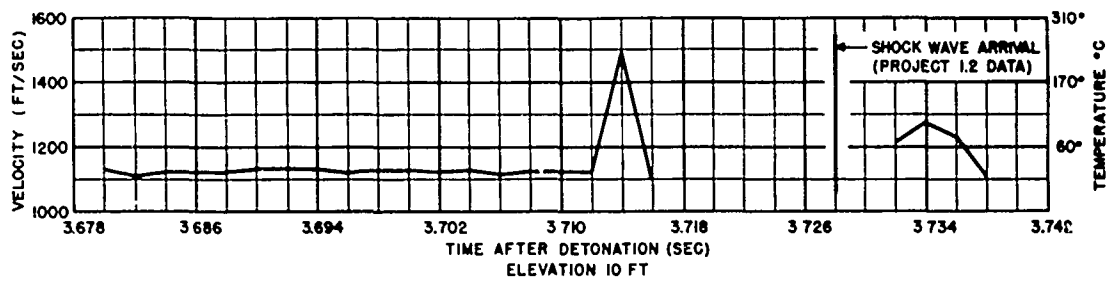
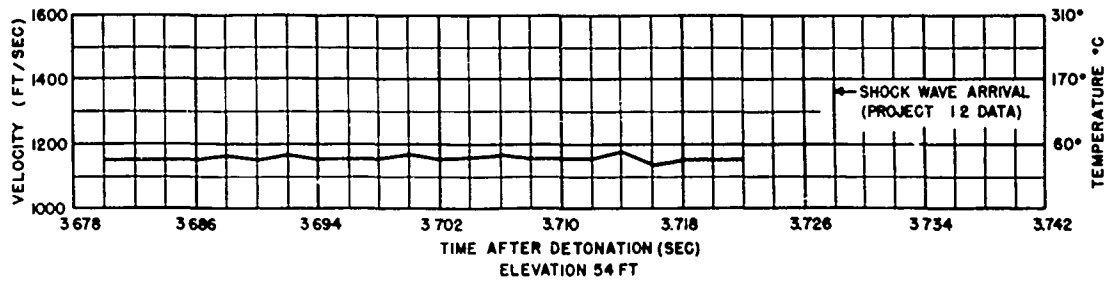

Fig. 3.17 Acoustic Velocity Vs Time Curves Tumbler 4, Tower 208

DISCUSSION

In this section the validity of the records in Chapt 3 will be discussed.

4.1 NOISE

Let noise be defined as any type of disturbance which prevents or hinders the reception of useful data. With this definition the following non-mutually exclusive noise phenomena will be considered.

4.1.1 Seismic Shock

Seismic shock was simulated by the NEL personnel who beat on the field equipment while it was running between tests. After elimination of microphonic tubes, no measurable disturbance was contributed by this type of shock. However, but of no consequence in the case of the NEL records desired, the signature of the seismic wave was left on all Brush paper records, simply because the recorders themselves were jarred by the wave.

4.1.2 Electromagnetic Transients

Electromagnetic transients from the detonation did occur. They did not hinder and, on the contrary, gave the most accurate zero time mark on the NEL records. They are observable on all records - paper, magnetic tape and film. (See figures 2.17, also figures 2.13 through 2.15).

4.1.3 Transducer Movements

The seismic wave might flex the arm supporting the transducers causing the more distant from the pole to vibrate with a sizeable amplitude. The shift with respect to the 500 cps wave (whose wave length exceeds 2 ft at 20°C) is negligible. Movement of the clamps on the pipe prior to shock wave arrival is improbable.

4.1.4 Acoustic Noises in the 10 Kc Region

An acoustic noise test of the effect of a single JATO unit at 500-foot distance, and with the receiver pointed at the JATO which was oriented at right angles to the air path, was made by NEL

at Naval Air Station, North Island, Calif., on 3 March 1952. No noise was picked up by the NEL equipment. It is very possible that high temperature sand may give off noises with components in the 10 Kc region too. The $1\frac{1}{2}$ foot transducers would suffer the most from this effect.

4.1.5 Wind Noise

There is no doubt that wind noise did exist. It was noted by the NEL investigators that great shifts in the air-borne acoustic signals occurred during periods of gustiness when they were working on their field equipment between tests. Other observers^{18/} have noted contributing causes for this. Schilling and his co-workers observed that air temperatures near the ground on ordinary days in the month of May in Pennsylvania sometimes shifted as much as 10°C in less than 2 seconds. In the test area the NEL experimenters encountered extremely gusty conditions. There is no doubt that the acoustic signal in the air path was being shifted by this wind of changing temperature because modulation of the 500 cps signal could be readily detected by clipping a pair of earphones onto the demodulator and listening. This effect vanished when the 4 terminal network of transducers was replaced by a 4 terminal all electrical element network of similar phase shifting characteristics. Assuming wind velocity shifts of 20 feet/second in a matter of seconds combined with temperature variations of 10°C in the same period, variations of 4% in measured velocity could be observed, and this was all due to the relatively mild stimulus of the sunshine. This being true, it is not surprising that the various investigating agencies, who were using equipment of 0.1 second time constant and less, observed such varied magnitudes of velocity and temperature in the period between the atomic detonation and its associated shockwave arrival. If the modulation observed is in amplitude rather than in frequency, the cause is probably destructive interference, explained in section 4.1.6 below.

4.1.6 Reflection and Refraction Effects

The reflection and refraction being discussed are those of the signal between the transducers. Reflection effects of the sound beam from external objects are considered negligible for the following reasons,

1. The 500 cps signal is being transported by the 10 Kc carrier and the wavelength of the latter is approximately 1.4 inches at 20°C.
2. The conical horn, which is an inherent part of the transducer loudspeaker element and whose mouth is one inch in diameter,

^{18/} See reference 6, bib.

has an additional horn coupled to its mouth. The throat diameter of the second horn is 1 inch to match that of the other's mouth. Its mouth diameter is 2 inches and its length is 3/4 inch. The use of this latter horn on a single transducer yields a 3 db increase in signal strength over that obtained when no horn is used. Its directionality pattern at 10 Kc is 40° between half power points. Standing waves between transducers are eliminated by sloping the horn face back from its mouth.

3. Large solid objects introduced into the air gap do introduce reflections but this phenomenon is not expected before shock wave arrival.

4. Shovelfuls of sand thrown through the gap contribute no discernible effects as this was tried while working on the equipment between tests.

Refraction, unlike reflection, is a very probable cause of noise. Two very likely effects are described below.

1. If the receiver were suddenly to be engulfed in a sphere of high temperature air,^{19/} the signal intensity would diminish as the waves would be spread over a wider area and the acoustic spikes at the control cab could become small enough to fail to trip the "flip-flop" circuit. Figure 4.1 shows this phenomenon for regions of velocity of magnitude V and $2V$.

2. A more serious condition would be obtained if a "prism" of hot air were to suddenly occur in the air gap. The resulting destructive interference at the receiver due to multiple path arrivals could reduce the eventual acoustic spikes to zero and not only would the "flip-flop" circuit fail to trip,^{20/} introducing a spurious velocity on the paper tape, but also there would be no way of determining velocity from the magnetic records either.

4.1.7 Turbulence^{21/}

The condition existing when the heat content of the desert sand is suddenly raised above ambient and the soil must dissipate its energy to the air above is strongly conducive to convection cur-

^{19/} Schilling and his co-workers predict this type of phenomenon due to solar radiation, ref 6, p 349, bib.

^{20/} See discussion on Noise Signals on Paper Tapes, sect 4.1.8.

^{21/} For more mathematical rigor, see ref 5., bib.

rents.^{22/} These currents, if visible, would resemble the smoke rings often observed emitted from the stacks of steam locomotives. The hot gases in the center rise upward, turn outward, bend downward, come inward and go up again. The passage of masses of air of different temperatures changes the acoustic velocity measured in the air gap. NEL conducted its own noise tests along these lines and succeeded in shifting the velocity by small amounts. See figures 4.2 and 4.3. The conditions for the 2 tests made were as follows.

1. Two small blow torches were held about 6 inches below the axial line of the transducers and about 2 feet apart, spaced symmetrically about the air gap center point.

2. Suspecting the possibility of acoustic noise pick-up by the receiver in the above test, pieces of paper were then burned under the air gap so that the hot gasses were rising through the path. Again the characteristic velocity shift was in evidence.

4.1.8 Noise Signals On Paper Tapes

The combination of turbulence and multiple path signals due to refraction is considered the major source of noise. The NEL paper tape field records are excellent examples of what the noise did to the system. The failure of an acoustic spike to trip the Eccles-Jordan circuit^{23/} caused the instrument to "assume" that the acoustic spike was very slow in arriving. That is, the velocity in the air gap was small. The result was that the pen went up^{24/} to a low velocity level, came down when the next reference spike came in, and went back up again if the next acoustic spike was also too small to trip the "flip-flop". The velocity vs time records obtained through an analysis of the magnetic tapes do not exhibit these velocity decreases, of course,^{25/} and are consequently much more reliable. However, even in the latter case there are sometimes periods of no data when the acoustic spikes go to zero amplitude, e.g., see fig 2.17 or table C.18.

22/ For an analagous laboratory situation see the discussion of the Benard cell, ref 3, p 219, bib.

23/ See discussion of phase discriminator in sect 2.3.4 and in the Appendix.

24/ In figures 2.13 through 2.15 of velocity vs time, increasing velocity is downward, increasing time to the right.

25/ Since the "flip-flop" circuit was not a part of this system, see sect 2.3.4 for instrumentation details.

4.2 ACCURACY

4.2.1 Velocity Error Due To Cool Air In Transducers

At the time that Project 8.6 was conceived it was generally assumed that at any given time the temperature vs distance plot from the front of one transducer to the other would be relatively constant, probably showing some variations at the transducer faces. It was felt, however, that the air within the horns which connect the transducer diaphragm to the atmosphere would be generally cooler than that outside. Consequently, the total path was made large with respect to that within the horns to minimize the relative error.^{26/} The theoretical maximum probable error in velocity obtained by assuming constant velocity over the whole path when 5 inches of the travel is within horns where the velocity is half way between ambient and that in the air path is 12 per cent for maximum temperatures encountered in Tumbler 4, and 6 per cent for maximum temperatures encountered in Tumbler 3. Table 4.1 gives the theoretical probable errors due to this effect for the Tumbler 3 and 4 velocity magnitudes given in chapt 3.

With the type of turbulence actually encountered, it is probable that the air in the horns got hotter than that indicated in the above assumption, with a resultant decrease in the maximum probable error.

4.2.2 Velocity Error Due To Horn Effect

Since the velocity of sound in a horn is not that of sound in free space, an experiment was performed to determine the magnitude of this effect on the NEL transducers. Two NEL sound velocity meters were set up in a paint oven and the temperature varied from 70°F to 200°F. These temperature readings were taken from the oven's thermometer. The velocities obtained from the two meters are given in table 4.2.

It will be noted that in no case was an error as great as 2 per cent encountered. But it seems that the oven's thermometer was contributing more error than the velocity meters which were generally in better agreement with each other than the thermometer was with either of them. Consequently, under these conditions the velocity meters are much better than the 2 per cent figure indicated by table 4.2.

^{26/} Another effect of large interdiaphragm distance is increased sensitivity but lower signal/noise.

TABLE 4.1

Probable Errors Due to Cool Air in Transducers

Temp (°C)	Actual Velocity (ft/sec)	Tumbler 3 (Interdiaphragm Distance 3 ft) Error (%)	Tumbler 4 (Interdiaphragm Distance 1.99 ft) Error (%)
500	1840	3	4
1000	2340	5	7
2000	3200	6	9
4000	4300	8	11
6000	5220	8	12

In the above table the usual correspondence between temperature and velocity applies. However, when applying the table to the measured velocities appearing in figs. 3.1 through 3.17, it should be remembered that these measured velocities include wind. Consequently, the errors indicated in Table 4.1 will be too high for velocity data containing large wind components.

TABLE 4.2

Velocity Errors for Two NEL Velocity Meters for Temperatures from 70°F to 200°F

Temp as Given by Oven Thermometer (°F)	Velocity if Oven Temperatures are Correct (m/sec)	Velocity Found by Meter 1 (m/sec)	Error (%)	Velocity Found By Meter 2 (m/sec)	Error (%)
70	344	350.5	1.7	350.0	1.7
110	357	354.4	-0.8	355.2	-0.5
120	360	354.4	-1.6	355.1	-1.4
140	365	364.1	-0.3	364.0	-0.2
155	371	373.0	0.5	373.7	0.8
160	372	374.7	0.8	373.9	0.4
170	375	379.1	1.1	374.2	-0.2
180	378	384.1	1.6	381.5	0.9
190	381	384.1	0.8	381.9	0.2
200	384	382.7	-0.3	380.8	-0.9

Security Information

4.2.3 Velocity Error in Reading Spike Spacing

The photographic records obtained from the magnetic tape records are analyzed in the following way. The distance S_1 on the film between a reference spike and its associated acoustic twin which arrives $\Delta t_a + \Delta t_{em}$ secs later is measured. Then the distance S_2 between the same reference spike and the reference spike occurring 0.004 secs later is measured.

$$\text{Therefore, } \frac{S_1}{S_2} = \frac{\Delta t_a + \Delta t_{em}}{0.004} \quad \text{Eq. (4.1)}$$

Solving for Δt_a :

$$\Delta t_a = \frac{4S_1}{1000S_2} - \Delta t_{em} \text{ secs} \quad \text{Eq. (4.2)}$$

All the quantities on the right hand side of Eq.4.2 are known and so Δt_a is determined and, consequently, the velocity is now known by Eq. 2.3. The actual measurement error in determining S_1/S_2 and also Δt_{em} is about 0.2 per cent, negligible when compared with the other errors encountered.

4.3 CALIBRATION

Calibration consists of two parts.

1. The determination of the electro-mechanical time delay of the system at the start of the test. (This technique is described in section 2.2.)
2. A determination of the ratio (pen deflection)/(velocity change) for each channel recorded on the paper tapes.

The technique for 2 is as follows. The experimenter takes the temperature for the transducers' location. Knowing this, the velocity at the transducers is known, and therefore, for a given inter-diaphragm distance d , Δt_a is known. (See sect 2.2.) This velocity corresponds to a certain pen position. Now the system's time delay is changed by inserting 22° of phase shift in the direction of increasing velocity, (i.e., lesser time delay)^{27/} The advancement of the 500 cps wave by 22° is tantamount to decreasing Δt_a by $2(22/360)$ msec.

^{27/} This is accomplished by having an initial time delay introduced at the van and greater than the time delay equivalent of 22° phase shift, say 50° . Then this is shifted to a time delay of 28° making the time delay less. The equivalent velocity shown on the paper consequently increases.

An equivalent velocity is therefore recorded on the paper and the ratio of the pen deflection in millimeters to the velocity change in ft/sec is defined as the calibration sensitivity.

4.4 SMALL ENERGY LOSSES DUE TO TURBULENCE AND WINDS

In section 1.1 the possibility of large energy losses due to turbulence and other air flow was mentioned. Losses of this type would appear to be due either to useless air movements or to some sort of interference of winds with the shock wave. In the latter case the wavefront would not be smooth. If it is true that interference had caused holes and bumps on the shockfront at the "close-in" towers, they had certainly been eliminated by the time the Mach stem had formed (See Project 1.2 data on the shock waves). It would seem that the useless movements theory can be readily disproved by a simple calculation where the postulated wind magnitude is greater than that measured in any case.

Assume that the total air movement associated with the explosion prior to shock arrival is contained in a disc of 4500 foot radius with center at ground zero (tower 206 is on periphery) and 10 feet in height and that the velocity of all air particles in this volume is, for example, of the order of ambient sound velocity.

Then the air particle velocity is approximately 1147 feet/second for a 20°C initial temperature.

The air density is assumed to be $1.105 \times 10^{-3} \text{ gm/cm}^3$. Therefore the kinetic energy of the air in the disc is $1.217 (10)^{19}$ ergs. This is equivalent to less than 0.3 KT of TNT, and for a 20 KT bomb the pressure loss would be less than 0.6 per cent. Admittedly the calculation is crude but the small magnitude of the answer does indicate that this is not the source of destructive energy loss being sought.

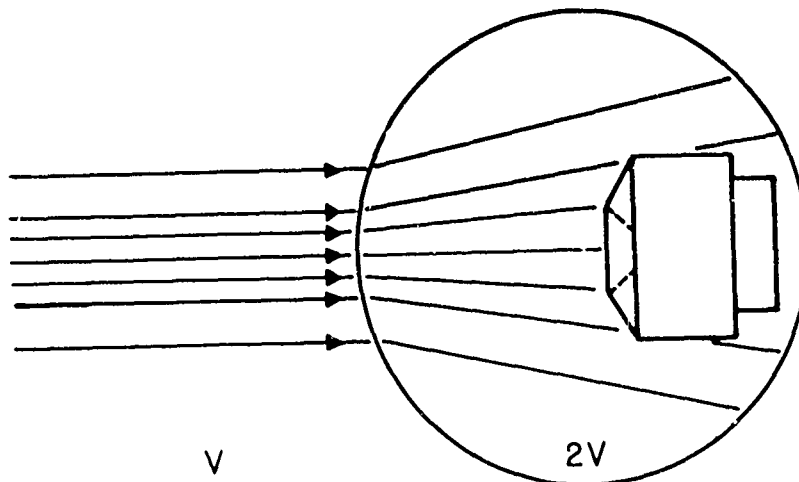

Fig. 4.1 Refraction Due to Hot Air Surrounding Receiver

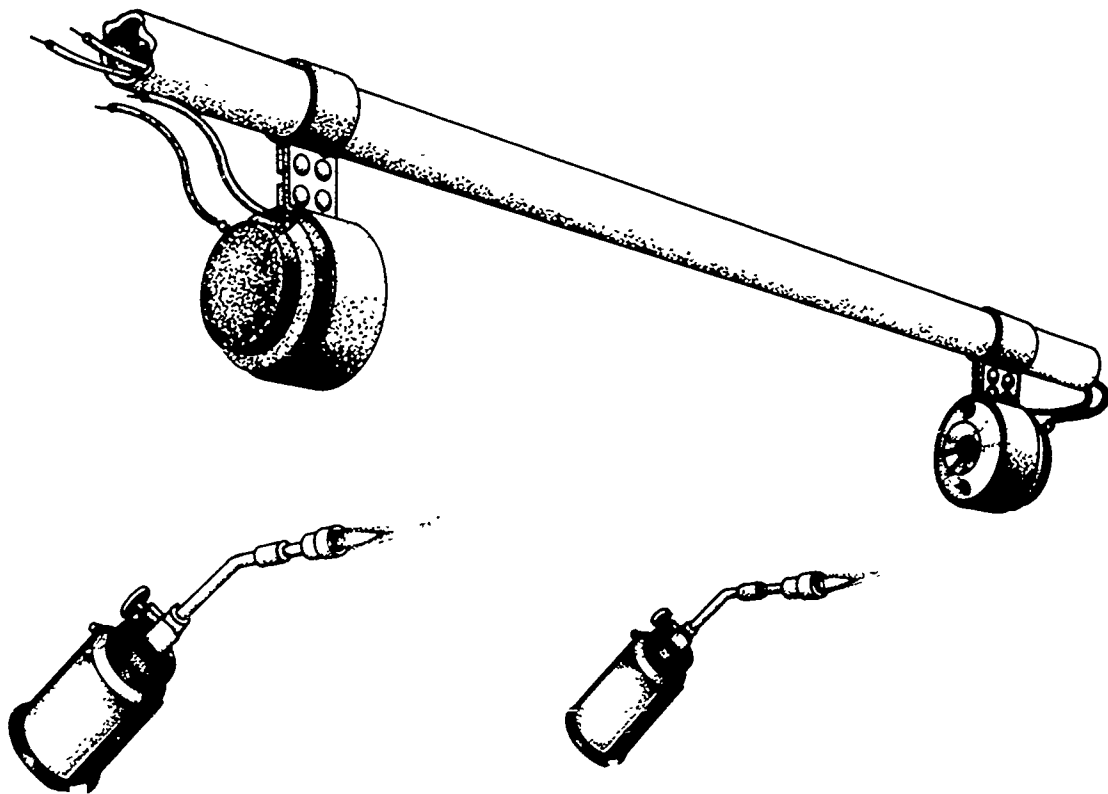

Fig. 4.2 Artificial Noise Test

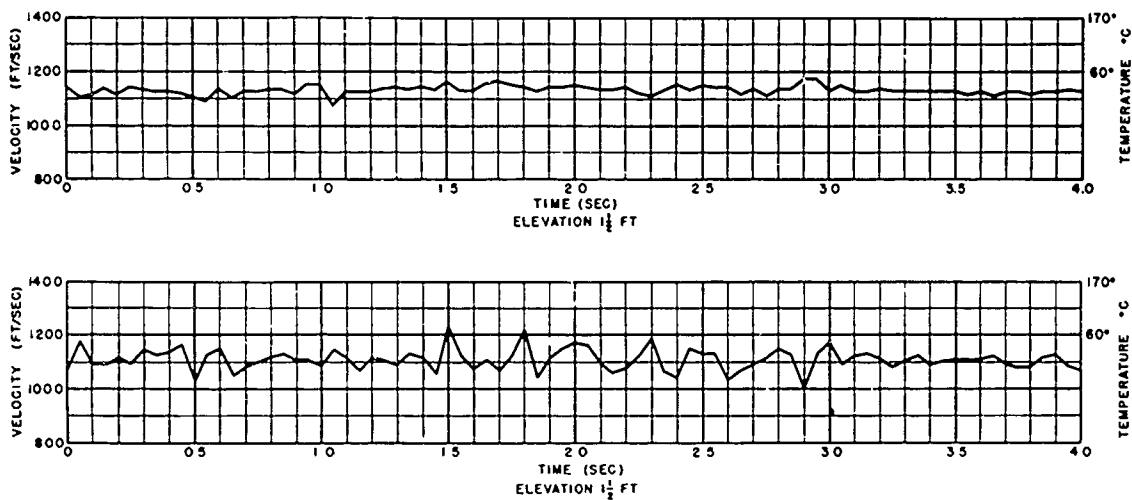

Fig. 4.3 Noise Test at Tower 202. Upper Graph is that for Paper Burning Between Transducers. Lower Graph is that for Blowtorches Held Under Air Path

CONCLUSIONS AND RECOMMENDATIONS5.1 TUMBLER 3 AND 4 DATA

The Tumbler 3 and 4 data given in tables C.1 through D.23 and figures 3.1 through 3.17 represent the best efforts of NEL to furnish regular acoustic velocities at the predetermined times and places. The data of tables D.1 through D.23 and figures 3.10 through 3.17 describe velocity conditions approximately 50 milliseconds before shock wave arrival. These data have a 2 millisecond time resolution and should be used rather than the data in tables C.1 through C.26 or figures 3.1 through 3.9 when determining the effects of velocity conditions just prior to shock wave arrival. The data of figures 3.1 through 3.9 have a 50 millisecond resolution. They describe conditions for 4 seconds after detonation. A comparison of these data with the NRDL temperature measurements²⁸ yields quite encouraging correlations. A qualitative comparison of NRDL and NEL data are given in table 5.1.

In figures 3.1 through 3.17, gradual velocity change is attributed to average temperature and wind, and the large amplitude fluctuations are felt to be caused by turbulence and temperature gradients in the air.

The Tumbler 3, Tower 204, nominal 54 foot elevation data for NEL and NRDL show the best agreement of all these records. The NRDL temperature of 5°C above ambient for preshock gives a total temperature of approximately 25°C at that time.²⁹ This agrees very well with the NEL preshock velocity data given in figure 3.3. The SRI total shock pressure figure of 6.5 psi³⁰ would indicate the presence of a post-shock wind velocity of 300 feet per second.³¹ The component of the latter velocity along the line between the transducers is approximately 200 feet per second as the angle of incidence of the shock wave is about 42° at Tower 204.

The sum of the post-shock acoustic velocity obtained from temperature data (1200 ft/sec) and the wind velocity predicted from

²⁸/ Reference 2, bib.

²⁹/ Page 26, reference 2, bib.

³⁰/ Page 25, Reference 4, bib.

³¹/ Page 125, reference 8, bib.

pressure data (200 ft/sec) yields 1400 feet per second as an expected post-shock measured velocity. The NEL data in figure 3.7 substantiate this 0.1 seconds after shock. The data taken right at shock arrival and for 0.1 seconds after are not considered reliable. Too many spikes were missing in that interval and it is reasoned that a phenomenon which can obliterate spikes can conceivably give erroneous velocity values for the spikes which are received in that time.

There are too many data to warrant a discussion of them all in the above manner for this report. However, it is believed that the rest of the records are as reliable in the pre-shock arrival interval as these, at least during the times when there are plenty of information spikes being recorded. In the post-shock arrival period, all NEL data are subject to suspicion as in all cases the compliance of the transducer diaphragms is changed roughly in inverse proportion to the distance from the blast. A measure of the distortion introduced by this has not been made. However, NEL was not expected to furnish data after shock wave arrival anyway, and the above is only cited to prevent a possible misinterpretation of the post-shock interval data.

5.2 TUMBLER 1 AND 2 DATA

No Tumbler 1 data were obtained because of equipment failure. Excessive noise present in the Tumbler 2 test prevented any useful information from being obtained at that time.

5.3 EQUIPMENT IMPROVEMENT

5.3.1 Concrete Rooms

It is suggested that the field electronic equipment be housed in concrete underground rooms in future tests. The rooms should be large enough so that a man can get inside and work readily. This would tend to keep sand out of the equipment. It is believed that the failure to obtain data at Tower 208 in Tumbler 3 was due to sand in a relay.

5.3.2 Immediate Data at Test Site

NEL hopes to improve its system of recording velocity directly on a paper tape in the field. If the noise problems in the aforementioned can be resolved, data of 0.1 second time resolution will be available immediately after each test.

TABLE 5.1

Correlation of NEL Velocity Data and NRDL Temperature Data

Tumbler Number	Tower Number	Elev (Ft)	Correlation	No Correlation	Remarks
3	200	54	x		Good agreement
		10	x		Good agreement
		1½			NRDL unit failed before 0.4 secs
3	202	54	x		Fair agreement
		10	x		Fair agreement
		1½	x		Fair agreement
3	204	54	x		Very good agreement
		10		x	Poor amplitude agreement
		1½	x		Good agreement
3	206	54	x		Good agreement
		10	x		Good agreement
		1½		x	Poor agreement
3	208	54			NEL units at tower 208 failed to turn on
		10			
		1½			
4	200	54			No NRDL records given for tower 200
		10			
		1½			

NEL instrument levels 1½, 10, 54 feet
 NRDL " " 1, 10, 50 feet

TABLE 5.1 (Cont.)

Correlation of NEL Velocity Data and NRDL Temperature Data

Tumbler Number	Tower Number	Elev (Ft)	Correlation	No Correlation	Remarks
4	202	54		x	Poor agreement
		10			NEL unit failed
		1½			NRDL unit failed at 1000 C° but NEL recorded 2000°C
4	204	54	x		Fair agreement
		10			No NRDL preshock values given
		1½			NEL unit failed
4	206	54	x		Magnitudes different at shock arrival but otherwise similar
		10	x		Good agreement
		1½			No NRDL preshock values given
4	208	54			No NRDL preshock values given
		10	x		Good agreement
		1½	x		Fair agreement but magnitudes quite different

APPENDIX A

DETAILS OF INSTRUMENTATION

~~SECRET~~
on

~~SECRET~~

A.1 STATEMENT

The following descriptions of instruments were written by the engineers who made the first mock-ups. Instrument components are listed in Appendix A of the NEL Preliminary Report "Sound Velocity Changes Near the Ground in the Vicinity of an Atomic Explosion".

A.2 FIVE-HUNDRED CYCLE PER SECOND SIGNAL GENERATOR by J. R. O'Neill

Refer to figures A.1 and A.2 for block diagram and schematic.

This unit furnishes five separate channels of 500 cps sine wave and one output of 500 cps pulses.

The 500 cps signal is generated within the unit. Separate power amplifiers present the signal to their respective 600 ohm balanced lines. The 500 cps signal also drives a pulse generator which provides the reference pulse for the phase discriminators. A circuit is included for introducing a momentary incremental phase shift into the system. The unit requires 300 volts DC at 60 ma and 6.3 volts AC at 3.6 amperes.

A Wein bridge oscillator generates the 500 cps voltage. Two halves of a 12AT7 tube (V101) are used for the amplifier portion of the oscillator. The frequency is controlled by R103 and R106. R148 automatically regulates the amplitude of the generated voltage.

Five separate power amplifiers feed the 500 cps sine wave to the 600 ohm balanced line. Triode power amplifiers (V102, V103, 1/2 V104) couple through transformers to the lines. Signal levels on each line may be adjusted by the gain control on the corresponding amplifier (R112, R116, R120, R124, R128). A meter (M101) is included for reading line signal levels.

The pulse generator input is taken directly from the 500 cps oscillator output. One-half of V104 amplifies the signal and feeds it to the limiter V105. The signal is differentiated and coupled to the pulse line of V106. Input to the pulse generator is regulated by R132.

A phase shift may be introduced in the signal entering the pulse generator by operating either S101 or a remote switch. When S101 is closed, the phase change remains for as long as the switch is depressed. When the field circuit is used, a timing circuit closes the phase shift network composed of R131, R132, R145, C116 and C110, thereby changing the phase of the signal passing through.

A.3 OSCILLATOR-MODULATOR-AMPLIFIER UNIT
by Donald E. Holcomb, Jr.

Refer to figures A.3 and A.4 for block diagram and schematic.

The unit provides 3 separate outputs of 10 Kc carrier modulated by a 500 cps sine wave. A local oscillator furnishes a 10 Kc carrier to a balanced modulator. The carrier is modulated by a 500 cps signal from an external 600 ohm balanced source. The signal from the modulator is used to drive 3 separate power amplifiers of 8 watts maximum sine wave power output each. Outputs are 16 ohm balanced.

A power supply for the unit must furnish 6.3 volts AC or DC at 3.6 amps, 180 volts DC at 7 ma, and 250 volts DC at 230 ma.

The 10 Kc local oscillator is composed of a 2 tube 12AT7 cathode coupled amplifier with a temperature compensated tuned circuit in the positive feedback loop. Frequency adjustment over a limited range is afforded by a variable capacitor C203.

The phase inverter is of the single tube type. Using one half of a 12AT7 tube, it furnishes two signals at the carrier frequency with a 180 degree phase difference. Output is regulated by R210, the carrier adjust control.

A push-pull balanced modulator follows the phase inverter. The carrier signal is applied to the two grids of the 12AT7 modulator tubes, while the 500 cps modulating signal is coupled in through the cathode circuit. The modulating voltage is cancelled in the plate circuit, and only the carrier and side band frequencies appear in the output. R219 may be used to effect good balance in the circuit.

The 500 cps voltage comes from an external 600 ohm balanced source through the transformer T201, and thence through a selective network to the grid of the cathode follower input tube V202A, which drives the cathode of the modulator tube. Per cent modulation is set by the modulation voltage adjustment, R205.

The 10 Kc modulated signal appears at the grids of three separate push-pull amplifier stages using 6AQ5 tubes. Each tube pair is loaded by one 16 ohm balanced load through an output transformer. The maximum output for 100 per cent modulation is 3 watts, of which 2 watts are contained in the carrier and one watt is in the side bands.

Security Information

A.4 DEMODULATOR UNIT
by George O. Pickens

Refer to figures A.5 and A.6 for block diagram and schematic.

The demodulator had the primary function of detecting the 500 cps signal which had travelled across the air gap in the form of a modulating wave on a 10 Kc carrier.

The low level amplitude modulated carrier was conducted from the receiving transducer along a twisted and shielded pair which was balanced by the primary winding of the input transformer. This transformer, which was designed to favor frequencies in the vicinity of the carrier, matched the source impedance to the band-pass filter. This filter passed the carrier and side bands but presented 40 to 60 db loss to most of the noise frequencies. So effectively did it perform that there was never evidence of interference from airborne acoustic noise.

After filtering, the modulated carrier was amplified by a variable gain tube (V301). It was then demodulated and filtered by the diode (V302A) and the following network.

The detected 500 cps signal was amplified by the twin-triode V303 and matched to the transmission line by the output transformer. The other end of the transmission line was terminated and balanced to ground at the phase discriminator.

An AVC voltage was derived from diode V302B and associated network which sampled the output signal and controlled the gain of the first stage. Potentiometer R315, the only field adjustment, was used to set the output signal level.

The plate supply was well filtered by a choke-condenser combination to sufficiently isolate the demodulator channels from the electrical noise the modulator caused in the common battery supply.

Further decoupling was achieved for the first stage in each of the three demodulator channels by R303, C320B and C303.

A centertap for the heater supply was made by dividing resistors R301 and R302, a satisfactory arrangement where it was desired to permit high gain operation with either a DC or a balanced AC supply.

The purpose of the AVC was to give some degree of regulation to the level of the output signal in the presence of a long-time drift of input carrier level and/or percentage modulation. The AVC, however, was too slow to smooth out the short-time amplitude changes caused by certain velocity variations in the air path.

A.5 PHASE DISCRIMINATOR
by James R. Chiles, Jr.

Refer to figures A.7 and A.8 for block diagram and schematic.

The phase discriminator has three important functions:

- (1) To convert the phase modulated signal to spike form;
- (2) To combine the signal spike and reference spike for recording on magnetic tape, and
- (3) To generate a variable width square wave to drive a Brush pen paper recorder.

The phase modulated 500 cps signal is brought to the recording van by a balanced 500 ohm line. The primary of the input transformer T401 is balanced in reference to ground. Its center-tap is returned to ground through a 100 ohm limiting resistor inserted to protect the transformer primary from blast induced longitudinal line currents.

The secondary feeds into a low pass RC filter designed to eliminate all frequencies above 500 cps. A 180° phase shifter couples the signal to the grid of the limiter amplifier V401a. The 500 cps signal is further limited and the square wave at the plate of V401b is put through the differentiating circuit C408 and R412 (fig A.8). The sharp pulse produced in the differentiating network is amplified by V402a to approximately 200 volts peak amplitude. A cathode follower furnishes a low impedance output while preserving the pulse waveform.

A cathode follower, V407b, is provided to prevent loading of the reference pulse master-generator.

The signal pulse and reference pulse feed the magnetic tape recorder mixer-amplifier and the Brush paper recorder driver simultaneously.

The signal and reference pulses are combined across the common cathode resistor of V406a and V406b. The cathode follower, V407a, drives the magnetic tape recording head through impedance matching transformer, T402. A rectifier, 1N34, is connected across the primary of T402 to dampen the transients.

R436 insures that the recording head is supplied from a constant current source. Timing signals (3Kc sine wave) may be recorded simultaneously with pulses through the isolation resistor R433.

The signal and reference pulses are applied to opposite grids of the Eccles-Jordan network of V403a and V403b. The phase difference between pulses determines the conducting and nonconducting periods of

the "flip-flop" tubes. The square wave at the plate of V403b is fed through the clamper tube and detector V404 to the pen driver tube, V405.

A.6 RELAY CONTROL SYSTEM by William D. Campbell

A.6.1 General Description

Refer to wiring schematic, figure A.9.

The NEL control is started by the EGG relays which close in turn at -15 min., -5 min., and at -5 sec. The NEL system is composed of one 110 volt AC, 6 min. timing motor with a SPDT switch, one 110 volt AC, 1 min. timing motor with a SPDT switch, two 110 volt AC DPDT relays and one 110 volt AC 3PDT relay.

When the -15 min. EGG relay closes, it completes the AC circuit for the time mark generator, phase discriminators, and the 500 cps generator.

When the -5 min. EGG relay closes, it completes the AC circuit for the field unit power supplies, tape recorders, and paper recorders, and starts the 6 min. timing motor. The -15 min. EGG relay is wired in parallel with part of the -5 min. relay so that if the -15 min. EGG relay does not throw, the -5 min. relay will turn on all NEL equipment.

A.6.2 Normal Operation

When the -5 sec. EGG relay closes, it closes the 3PDT relay which now parallels both EGG relays so that if any EGG relay opens it makes no difference. Also the -5 sec. EGG relay closes a DPDT relay and starts a 1 min. timing motor. The DPDT relay breaks the circuit for the 6 min. motor, which has been running for 5 minutes, and the 1 min. timing motor at the end of a minute restarts the 6 min. motor which has reset itself so that it will now run for 6 minutes. At the end of the 6 minute interval all equipment is then turned off.

A.6.3 Possible Operation

If at the end of the 6 minutes from the -5 min. EGG relay, the -5 sec. EGG relay has not thrown, the 6 min. motor actuates a DPDT relay which shuts the recorders off, and holds itself open until the -5 sec. EGG relay closes. It also breaks the 6 min. motor circuit so that the motor resets itself. Now all conditions of normal operation described above apply with the one exception that the 6 min. motor is shut off at the time the -5 sec. relay closes.

A.7 TIME MARK GENERATOR
by James R. Chiles, Jr.

Refer to figures A.10 and A.11 for block diagram and schematic.

The Time Mark Generator furnishes very accurate time intervals which are recorded simultaneously on magnetic tape and paper recorders. A side marking relay controlled pen is used on the Brush recorders while a 3 Kc tone is injected in parallel with the signal to the magnetic tape recording head so as to superimpose timing information upon the test information.

In the "timer unit" the intervals are marked by pulses generated by a synchronous motor (Haydon) tripping a micro-switch. The motor operates on a frequency of 60 cps which is controlled by the tuning fork of an American Time Products Frequency Standard Type 2001. The frequency, and hence the motor speed, is accurate to at least 0.1%. A 6AQ5 push-pull power amplifier furnishes the power needed for the frequency standard to drive the synchronous motor.

An RC oscillator generates a 3 Kc signal which is amplified and distributed to three power amplifiers, each of which supplies 3 Kc to 5 separate magnetic recorders.

Normally, the side marking pens are energized and 3 Kc is supplied continuously to the magnetic tape recorders with periodic interruptions accomplished, by causing a multi-pole relay to de-energize the side-marking pens and to "short out" the drive voltage to the 6CA amplifier grid immediately following the 3 Kc oscillator.

Upon receipt of "Blue-box" information, a reversing relay is energized which, in turn, inverts the action of the "interval" relay so that the side-marking pens are normally de-energized and no 3 Kc energy is allowed to reach the tape recorders except when "gated" by the interval pulse generator.

The reversing relay can be reset to pre-shot conditions by a panel-mounted micro-switch.

It must be remembered that the pulses generated by the interval marker generator are not synchronized with or controlled by any external time standard. They merely mark accurate intervals.

External signals supply time information so as to synchronize NEL records with the Test Program time.

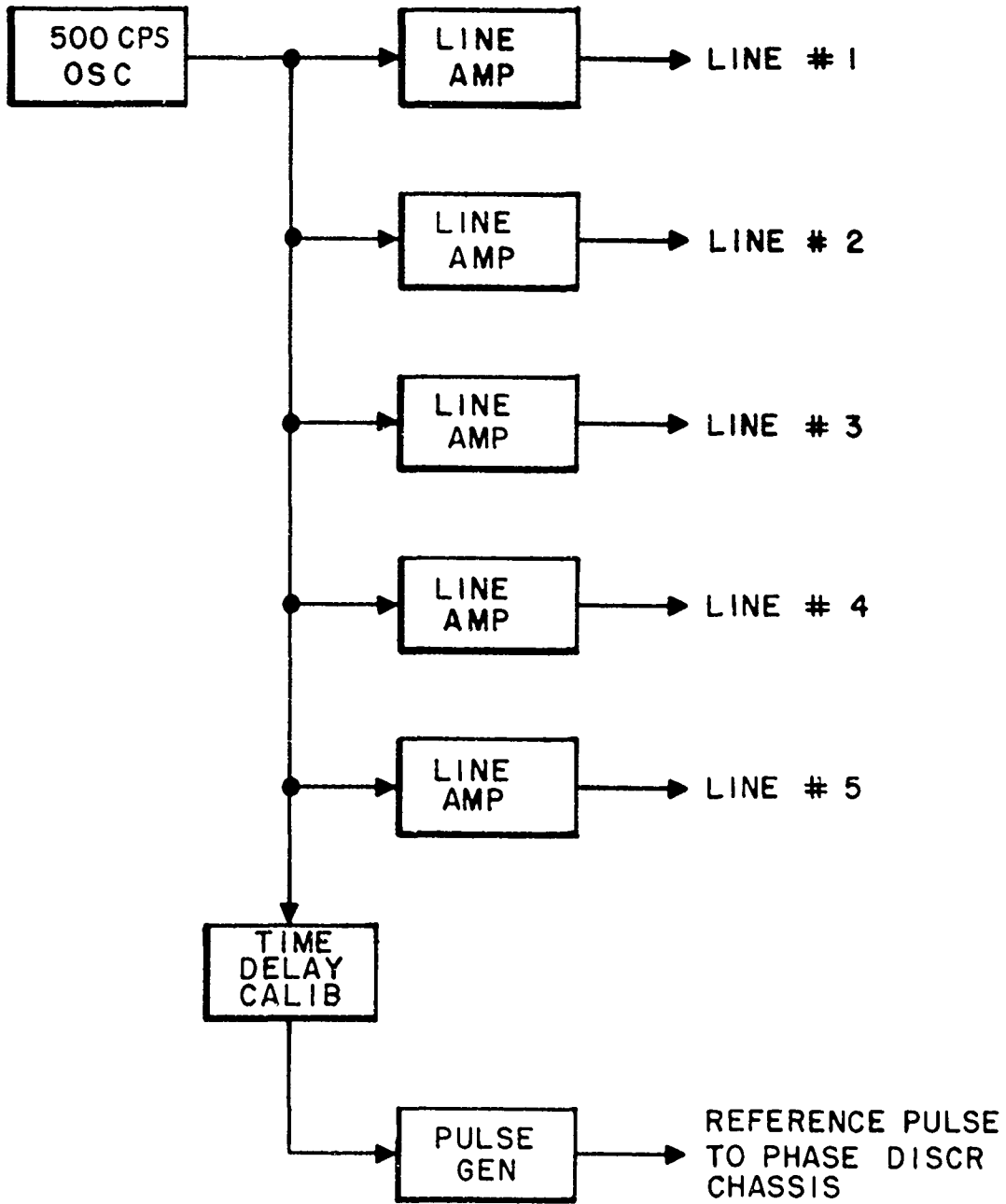

Fig. A.1 500 cps. Signal Generator Block Diagram

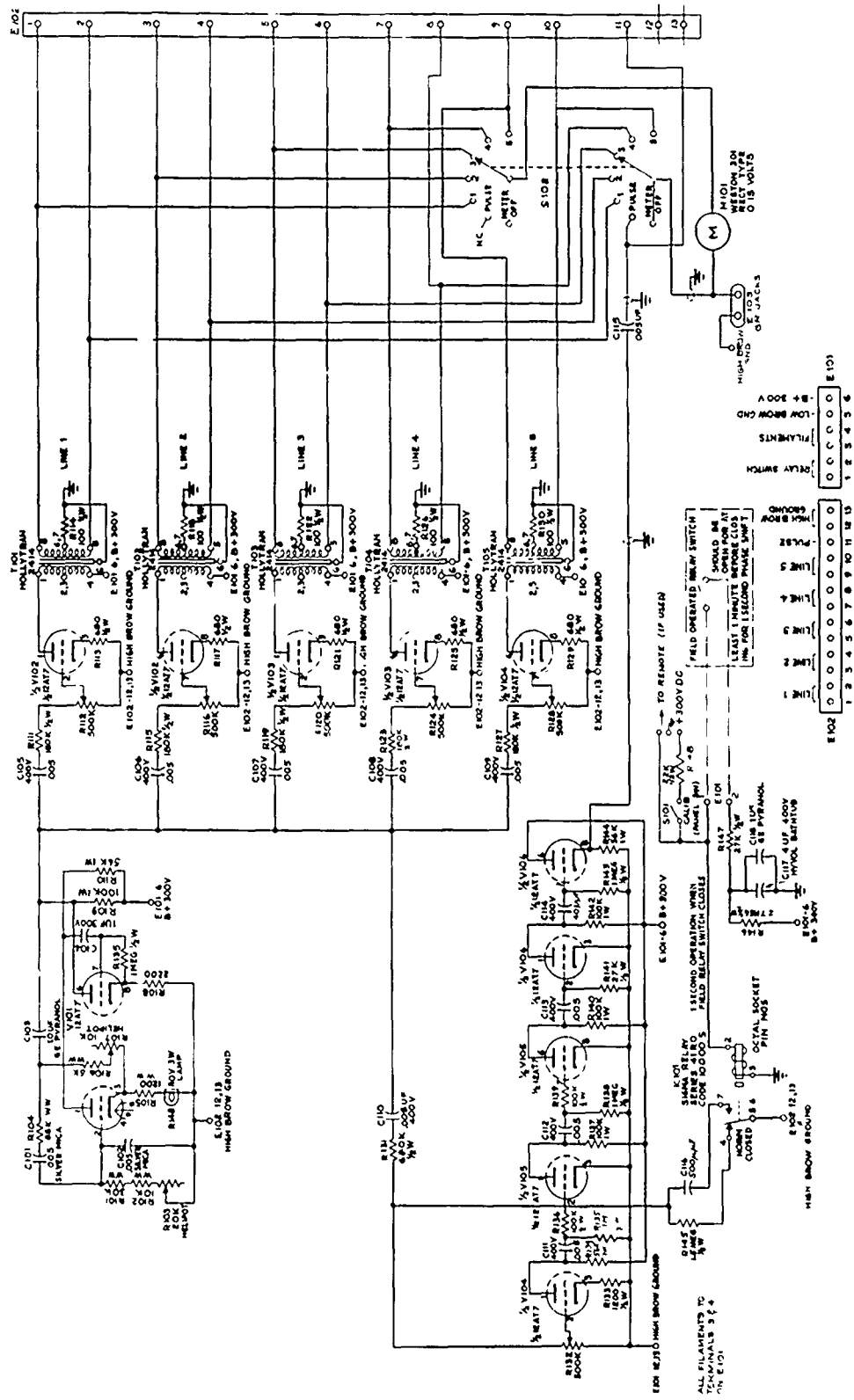

Fig. A.2 500 cps. Signal Generator Schematic

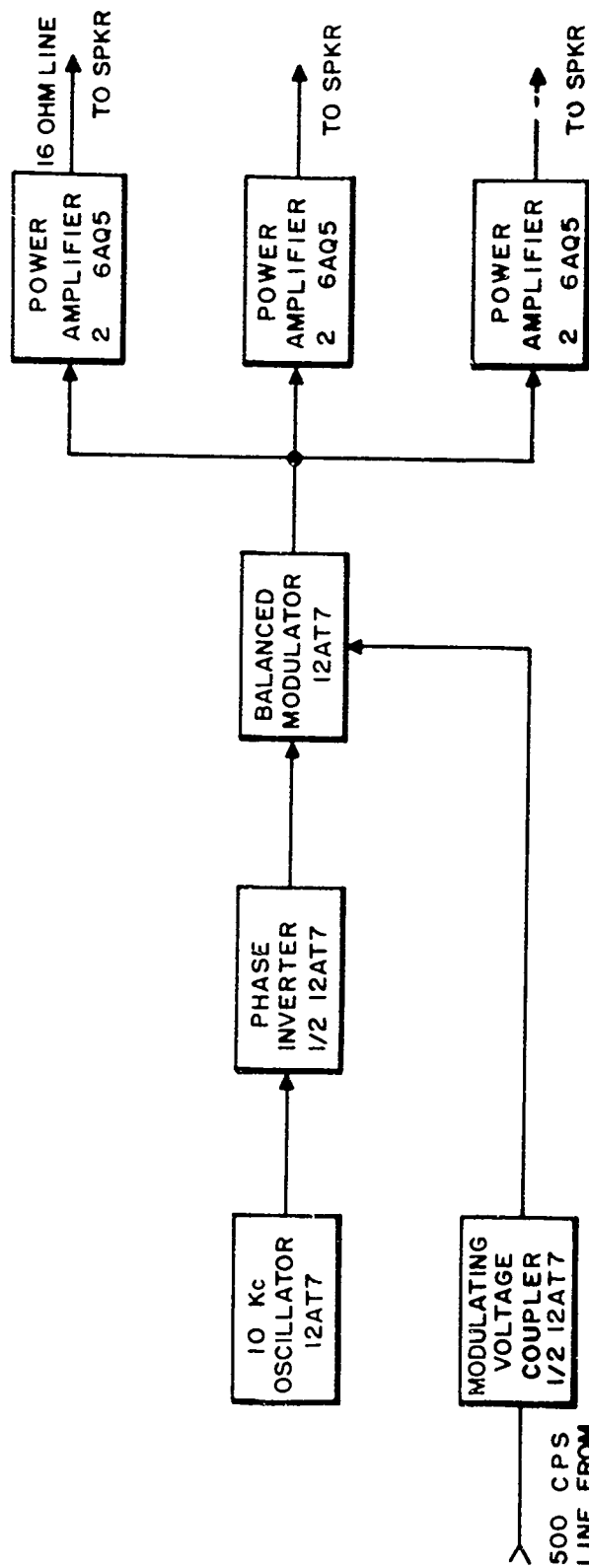

Fig. A.3 10 kc. Oscillator Modulator Unit Block Diagram

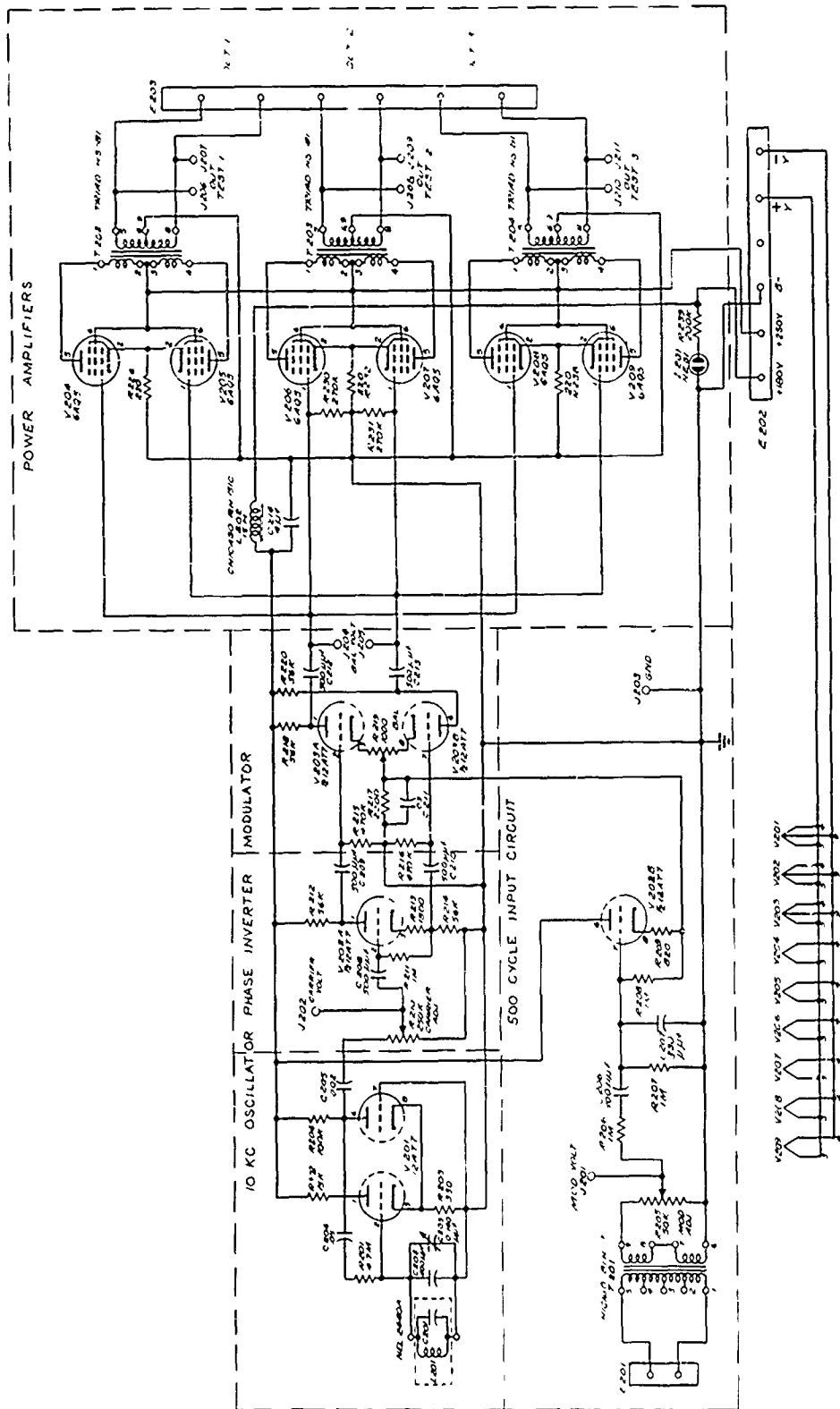

Fig. A.4 10 kc. Oscillator Modulator Unit Schematic

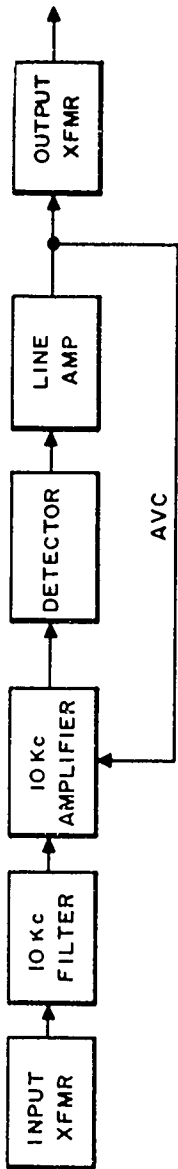

Fig. A.5 Demodulator Unit Block Diagram

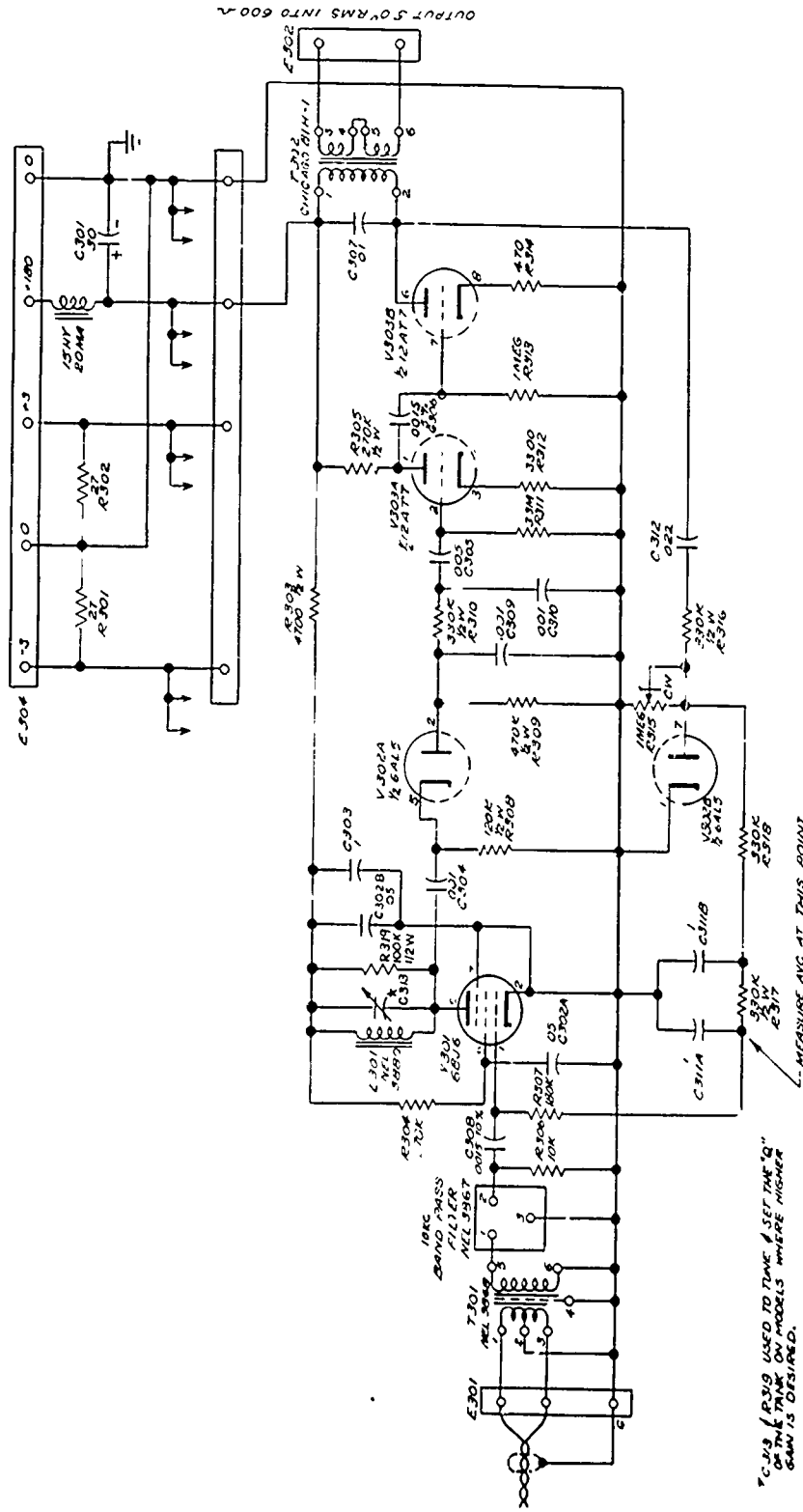

Fig. A.6 Demodulator Unit Schematic

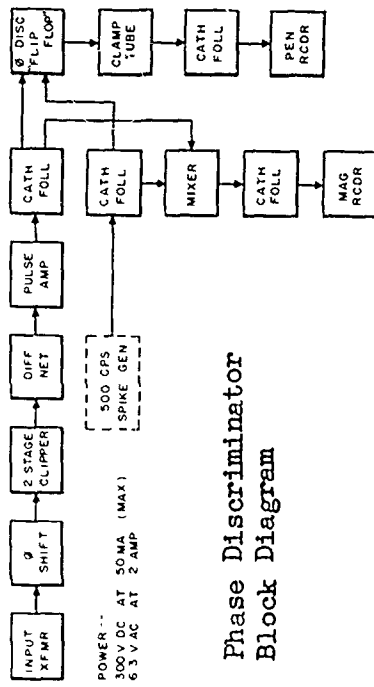

Fig. A.7 Phase Discriminator Block Diagram

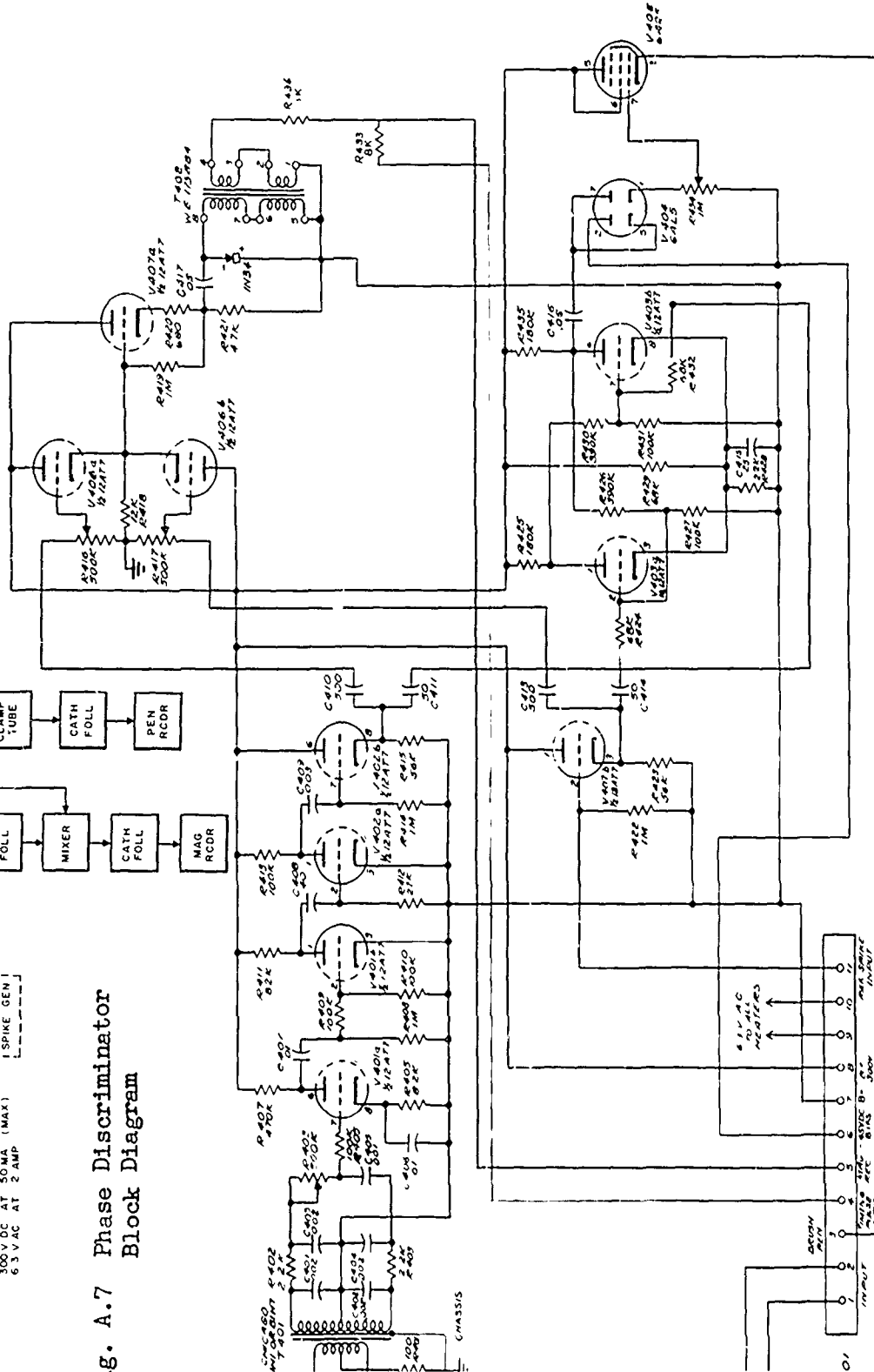

Fig. A.8 Phase Discriminator Schematic

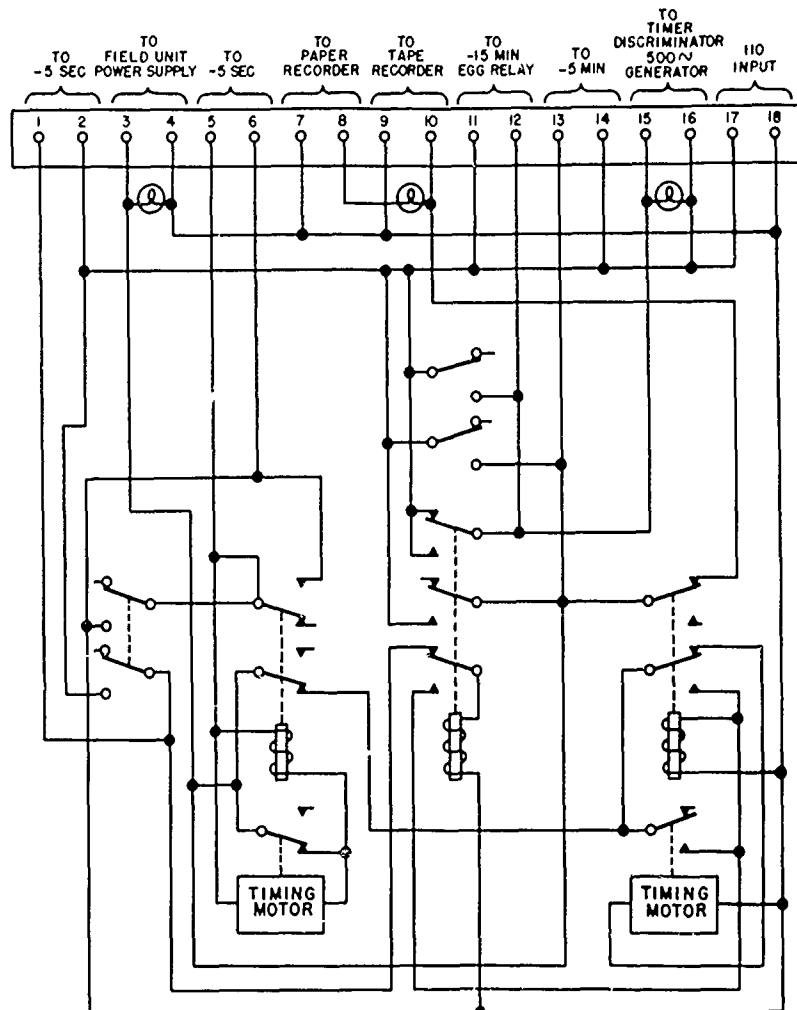

Fig. A.9 Relay Control Diagram Schematic

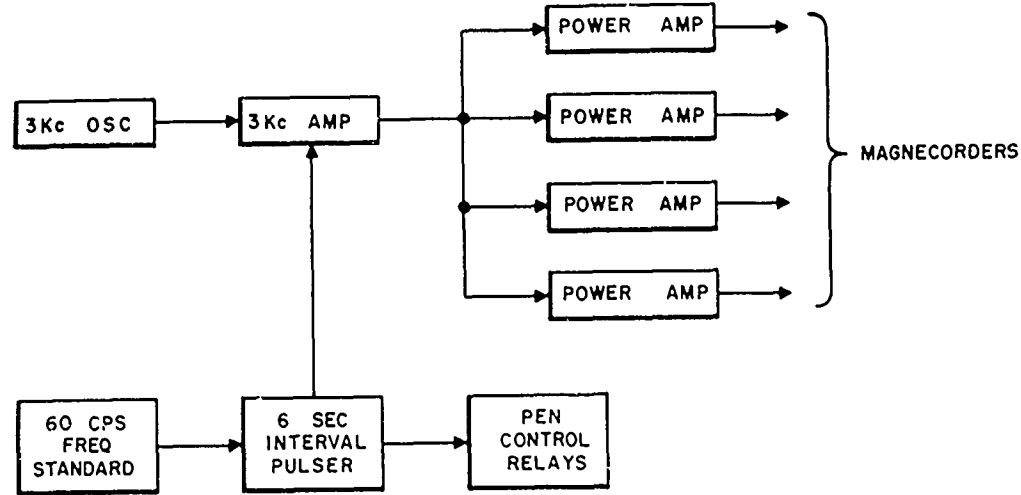

Fig. A.10 Time Mark Generator Block Diagram



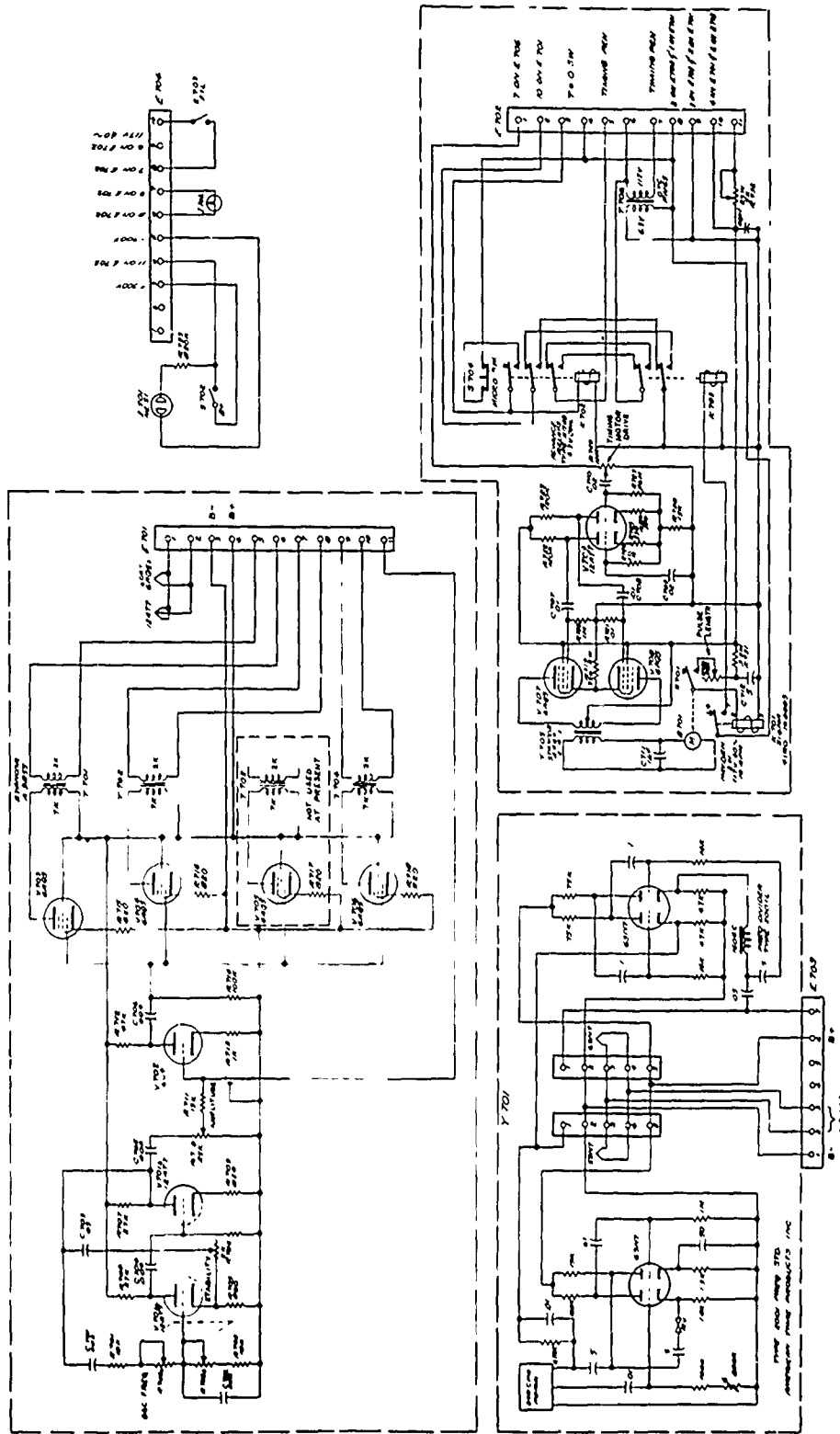

Fig. A.11 Time Mark Generator Schematic

[REDACTED]

APPENDIX B

SOUND FREQUENCY CONSIDERATIONS

by

G. O. Pickens

B.1 STATEMENT

The following is for the readers who are interested in the reasons for the 10 Kc sound carrier and in a post test evaluation.

B.2 EARLY PHILOSOPHY

It was of prime importance to minimize the effect of the very high level acoustic noise which accompanies one of these tests. The logical way was to strive for a high signal-to-noise ratio by (1) operating in a frequency band where the noise was less intense, (2) transmitting a strong signal, (3) directing this signal towards the receiving transducer, and (4) filtering out all but the desired band.

A frequency in the higher end of the audio range was compatible with all four points. There the noise was expected to be less intense. Also the signal could be focused towards the receiver without requiring large horn dimensions. The final choice of 10 Kc, other than its being a "round-number", was influenced by the transmission characteristics of the available transducers.

It was also important to hold to a minimum changes in phase shift in the electrical and mechanical parts of the system since they would be detected erroneously as changes in velocity. If a single audio note were used in the sound path objectionable phase shifts might have occurred in the receiving transducer and the following filter. This would be the case where the note received a frequency modulation from a changing velocity during its transit period in the air path. The same would be true for a carrier, but the angular phase shifts of the modulating wave would be only a fraction of the carrier by approximately the ratio of the modulating frequency to the carrier frequency. Actually, with or without the carrier the signal would also undergo relatively slight shifts in phase in the R-C networks elsewhere in the electrical circuits.

B.3 ACOUSTIC NOISE

The system seemed to be oblivious to all the acoustic noise generators at the test sight. Jatos, rockets, and mortars to mention a few went off undetected. Probably the noise accompanying and following the shock wave had no more than a destructive effect on the transducer diaphragms. Other disturbances, however, made this difficult to ascertain.

SECRET

B.4 DESTRUCTIVE INTERFERENCE

Undoubtedly the greatest source of trouble stemmed from the phenomenon which was responsible for the "noisy" pen records and the missing spikes on the magnetic tapes. The following are the arguments from several observations which seem to be pertinent.

It was found late in the design stage that a 10 Kc carrier underwent a 20 per cent amplitude modulation when transmitted over a 3-foot air path heated by a hot-plate. Such modulation was imperceptible when the frequency was lowered to 1 Kc.

In the field the 500 cps signal output of the demodulator had a tremolo. This tone had been conveyed in the air space by the carrier. The tremolo did not exist when the air link was replaced by an electrical attenuator.

During the extreme conditions of turbulence accompanying the shots the sound signal apparently faded out at times as was evidenced by the absence of the indicating spikes. It was not hard to believe that a tremolo, occurring when warm air pockets were moved by a light breeze, could grow under test conditions until a large random modulation occasionally cut off the carrier.

It was reasoned that an airborne sound of a longer wave length would have less tendency to cancel and reinforce itself while arriving along multiple paths with different delay times. So, on the final test an experimental channel was run, solely for the purpose of gaining more information about this effect.

The airpath frequency was a single tone (not modulated) of six times the wave length of the standard 10 Kc carrier. It was this frequency which conveyed the phase shifts to the detecting equipment. Under the same field condition where a standard channel produced a tremolo in the 500 cps tone, the tone from the experimental unit sounded clear and steady. The pen record made during this shot showed evidence that the signal never faded out. Although some acoustical noise apparently was picked up, the trace was without all the hash common to the other records. (By this time a low-pass pi-section filter had been added to each of the 15 standard channels to prevent the pens from being flipped from the sockets during periods of missing spikes.)

All of these observations seemed to substantiate, at least not refute, the theory that destructive interference was responsible for the hash on the pen records. Fortunately, records were also made on magnetic tape. While extracting their information was quite laborious, an occasional missing spike did no more than lose a bit of information from an over-abundant supply.

[REDACTED]

APPENDIX C

TUMBLER 3 AND 4 TABLES OF
ACOUSTIC VELOCITY VS TIME
FOR INTERVALS FROM DETONATION
TO 4 SECONDS (OR MORE) AFTERWARDS

[REDACTED]

[REDACTED]

[REDACTED]

TABLE C.1

Velocity vs Time Tumbler 3 Tower 200 Elevation 54 Ft
 Total Thermal Radiation 56 Cal/Cm² (from Project 8.3 Data)

Time (Secs)	Vel (Ft/Sec)	Time (Secs)	Vel (Ft/Sec)	Time (Secs)	Vel (Ft/Sec)
-0.20	1119	1.10	1172	2.50	1154
-0.15	1119	1.15	1172	2.55	1163
-0.10	1119	1.20	1163	2.60	1145
-0.05	1119	1.25	1230	2.65	1136
0.00 no spike		1.30	1163	2.70	1145
0.002	1351	1.35	1190	2.75	1136
0.05	1154	1.40	1190	2.80	1136
0.10	1111	1.45	1172	2.85	1132
0.15	1119	1.496	1111	2.90	1132
0.20	1119	1.50 no spike		2.95	1119
0.25	1172	1.55	1136	3.00	1136
0.30	1111	1.60	1181	3.05	1128
0.35	1136	1.65	1210	3.10	1128
0.40	1163	*1.70 no spike		3.15	1128
0.45	1136	1.702	1172	3.20	1128
0.50	1271	1.706	1705	3.25	1119
0.55	1136	1.75	1351	3.30	1128
0.594	1111	1.80	1136	3.35	1128
0.60 no spike		1.85	1376	3.40	1128
0.65 " "		1.90	1190	3.45	1128
0.656	1250	1.95	1190	3.50	1119
0.70	1181	2.00	1240	3.55	1128
0.748	1034	2.05	1190	3.60	1128
0.75	1154	2.10	1172	3.65	1128
0.80 no spike		2.15	1181	3.70	1132
0.85	1181	2.20	1293	3.75	1128
0.90	1210	2.25	1181	3.80	1128
0.95	1154	2.30	1136	3.85	1128
1.00	1190	2.35	1163	3.90	1132
1.05	1163	2.40	1154	3.95	1128
		2.45	1154	4.00	1128

* Shockwave arrival 1.671 (measurement by Project 1.2)

TABLE C.2

Velocity vs Time Tumbler 3 Tower 200 Elevation 10 Ft
 Total Thermal Radiation 56 Cal/Cm² (from Project 8.3 Data)

Time (Secs)	Vel (Ft/Sec)	Time (Secs)	Vel (Ft/Sec)	Time (Secs)	Vel (Ft/Sec)
-0.50	1115	0.95	1714	2.40	1395
-0.45	1124	1.00 no spike		2.45	1463
-0.40	1124	1.002	1333	2.50	1523
-0.35	1119	1.05 no spike		2.55	1435
-0.30	1115	1.054	1408	2.60	1492
-0.25	1111	1.10	1045	2.65	1478
-0.20	1115	1.148	1704	2.70	1463
-0.15	1119	1.15 no spike		2.75	1478
-0.10	1115	1.20	1172	2.80	1508
-0.05	1115	1.25 no spike		2.85	1508
0.00 no spike		1.252	1091	2.90	1478
0.02	1176	1.30	1167	2.95	1449
0.05	1115	1.35	1234	3.00	1604
0.10	1124	1.40	1205	3.05	1449
0.15	1132	1.45	1288	3.10	1435
0.20	1149	1.50	1141	3.15	1370
0.25	1119	1.55	1260	3.20	1422
0.30	1087	1.60 no spike		3.25	1382
0.35	1408	1.606	1370	3.30	1435
0.40	1531	1.65	1554	3.35	1435
0.45	1408	1.70 no spike		3.40	1395
0.50 no spike		*1.75	1370	3.45	1395
0.502	1205	1.80	1276	3.50	1370
0.55	1181	1.85	1195	3.55	1435
0.60 no spike		1.90	1210	3.60	1370
0.602	1676	1.95	1186	3.65	1382
0.65	1840	2.00	1205	3.70	1299
0.70	2190	2.05	1205	3.75 no spike	
0.75	1364	2.10	1158	3.756	1449
0.80 no spike		2.15	1288	3.80	1357
0.804	1079	2.20	1357	3.85	1523
0.85	1408	2.25	1357	3.90	1435
0.90 no spike		2.30	1345	3.95	1492
0.916	1382	2.35	1332	4.00	1449

* Shockwave arrival 1.702 (measurement by Project 1.2)

TABLE C.3

Velocity vs Time Tumbler 3 Tower 200 Elevation 1 1/2 Ft
 Total Thermal Radiation 56 Cal/Cm² (from Project 8.3 Data)

Time (Secs)	Vel (Ft/Sec)	Time (Secs)	Vel (Ft/Sec)	Time (Secs)	Vel (Ft/Sec)
-0.50	1115	0.90 no spike		2.25	1463
-0.45	1107	0.91	1695	2.30	1523
-0.40	1107	0.95 no spike		2.35	1523
-0.35	1115	0.96	1449	2.40	1523
-0.30	1132	1.00	1571	2.45	1554
-0.25	1124	1.05	1571	2.50	1508
-0.20	1141	1.10	1587	2.55	1523
-0.15	1124	1.15 no spike		2.60	1422
-0.10	1124	1.154	1523	2.65	1492
-0.05	1132	1.20	1587	2.70	1435
0.00 no spike		1.25	1403	2.75	1449
0.002	1068	1.30	1310	2.80	1435
0.05	1107	1.35	1435	2.85	1422
0.10	1124	1.40	1435	2.90	1422
0.15	1115	1.45	1422	2.95	1422
0.20	1158	1.50	1478	3.00	1408
0.25 no spike		1.55	1408	3.05	1435
0.252	1141	1.60 no spike		3.10	1408
0.30	1091	1.602	1395	3.15	1422
0.35	1167	1.648	1508	3.20	1435
0.40	1224	1.65 no spike		3.25	1395
0.45 no spike		1.70	1463	3.30	1449
0.456	1435	*1.75	1449	3.35	1435
0.50 no spike		1.798	2158	3.40	1408
0.508	1234	1.80 no spike		3.45	1395
0.55	1538	1.85	1523	3.50	1288
0.60 no spike		1.90	1587	3.55	1288
0.606	1370	1.948	1449	3.60	1310
0.65	1382	1.95 no spike		3.65	1345
0.70	1042	2.00	1587	3.70	1357
0.75	1276	2.05	1523	3.75	1345
0.80 no spike		2.10	1508	3.80	1370
0.808	1604	2.15	1357	3.85	1357
0.85	1266	2.20	1463	3.90	1422
				3.95	1408
				4.00	1408

* Shockwave arrival 1.708 (measurement by Project 1.2)

TABLE C.4

Velocity vs Time Tumbler 3 Tower 202 Elevation 54 Ft
 Total Thermal Radiation 50 Cal/Cm² (from Project 8.3 Data)

Time (Secs)	Vel (Ft/Sec)	Time (Secs)	Vel (Ft/Sec)	Time (Secs)	Vel (Ft/Sec)
-0.50	1128	0.95	1181	2.40	1200
-0.45	1119	1.00	1128	2.45	1181
-0.40	1119	1.05	1181	2.50	1181
-0.35	1128	1.10	1163	2.55	1163
-0.30	1128	1.15	1181	2.60	1163
-0.25	1119	1.20	1163	2.65	1163
-0.20	1119	1.25	1181	2.70	1154
-0.15	1103	1.30	1181	2.75	1154
-0.10	1128	1.35	1145	2.80	1136
-0.05	1119	1.40	1145	2.85	1145
0.00 no spike		1.45	1119	2.90	1128
0.05	1103	1.50	1145	2.95	1119
0.10	1119	1.55	1145	3.00	1128
0.15	1136	1.60	1145	3.05	1111
0.20	1136	1.65	1136	3.10	1103
0.25	1136	1.70	1128	3.15	1103
0.30	1163	1.75	1145	3.20	1111
0.35 no spike		1.80	1136	3.25	1119
0.40	1095	*1.85	1136	3.30	1128
0.45	1128	1.90	1271	3.35	1111
0.50	1128	1.95 no spike		3.40	1103
0.55	1163	2.00 " "		3.45	1103
0.60	1220	2.05	1145	3.50	1111
0.65	1210	2.10	1181	3.55	1111
0.70	1220	2.15	1172	3.60	1103
0.75	1210	2.20	1271	3.65	1095
0.80	1181	2.25	1240	3.70	1128
0.85	1181	2.30	1220	3.75	1119
0.90	1163	2.35	1210		

* Shockwave arrival 1.893 (measurement by Project 1.2)

TABLE C.5

Velocity vs Time Tumbler 3 Tower 202 Elevation 10 Ft
 Total Thermal Radiation 50 Cal/Cm² (from Project 8.3 Data)

Time (Secs)	Vel (Ft/Sec)	Time (Secs)	Vel (Ft/Sec)	Time (Secs)	Vel (Ft/Sec)
-0.40	1128	1.058	1136	2.45	1327
-0.35	1111	1.10	1154	2.50	1172
-0.30	1111	1.15	1200	2.55	1271
-0.25	1119	1.20	1163	2.60	1200
-0.20	1111	1.25	1200	2.65	1163
-0.15	1103	1.30	1230	2.70	1220
-0.10	1128	1.35	1163	2.75	1200
-0.05	1128	1.40	1119	2.80	1154
0.00	1119	1.45	1190	2.85	1364
0.05	1095	1.50	1230	2.90	1260
0.10	1095	1.55	1200	2.95	1220
0.15	1103	1.60	1200	3.00	1230
0.20	1103	1.64	1136	3.05 no spike	
0.25	1136	1.65 no spike		3.056	1250
0.30 no spike		1.70	1145	3.10	1293
0.31	1095	1.75	1190	3.15	1240
0.35	1103	1.80	1230	3.20	1230
0.40	1103	1.85	1230	3.25	1220
0.45	1119	1.90	1181	3.30	1190
0.50	1181	*1.95	1181	3.35	1230
0.55	1128	2.00	1163	3.40	1190
0.60	1154	2.05	1240	3.45	1172
0.65	1163	2.10	1230	3.50	1220
0.70	1128	2.15	1200	3.55	1210
0.75	1145	2.20	1260	3.60	1190
0.80	1145	2.25 no spike		3.65	1230
0.85	1190	2.258	1220	3.70	1210
0.90	1200	2.30	1282	3.75	1190
0.95	1111	2.35 no spike		3.80	1250
1.00	1079	2.36	1339	3.85	1304
1.05 no spike		2.40	2113	3.90	1200
				3.95	1145
				4.00	1027

* Shockwave arrival 1.922 (measurement by Project 1.2)

TABLE C.6

Velocity vs Time Tumbler 3 Tower 202 Elevation 1½ Ft
 Total Thermal Radiation 50 Cal/Cm² (from Project 8.3 Data)

Time (Secs)	Vel (Ft/Sec)	Time (Secs)	Vel (Ft/Sec)	Time (Secs)	Vel (Ft/Sec)
-0.50	1128	1.05	1470	2.45 no spike	
-0.45	1128	1.098	1613	2.484	1049
-0.40	1119	1.10 no spike		2.50 no spike	
-0.35	1119	1.148	1250	2.55 " "	
-0.30	1119	1.15 no spike		2.60 " "	
-0.25	1119	1.194	1316	2.64	1744
-0.20	1128	1.20 no spike		2.65 no spike	
-0.15	1128	1.25	1293	2.688	1948
-0.10	1128	1.30	1376	2.70 no spike	
-0.05	1119	1.35	1293	2.726	1899
0.00	1562	1.40	1327	2.75 no spike	
0.05	1765	1.45	1364	2.80	1875
0.10	1724	1.50 no spike		2.85 no spike	
0.15 no spike		1.514	1364	2.90 " "	
0.152	1562	1.548	1829	2.914	1852
0.20	1562	1.55 no spike		2.95	1829
0.25	1667	1.60	1415	2.998	1071
0.30	1786	1.65	1428	3.00 no spike	
0.35	1704	1.70	1485	3.054	1899
0.40	1685	1.75	1200	3.10	1724
0.45	1667	1.80	1428	3.146	1056
0.50	1630	1.85	1364	3.15 no spike	
0.55	1596	1.90	1630	3.20	1042
0.60	1579	*1.95	1704	3.236	2000
0.65	1704	2.00 no spike		3.25 no spike	
0.70	1442	2.05 " "		3.30 no spike	
0.75	1613	2.10 " "		3.326	1056
0.80	1596	2.15 " "		3.35	1744
0.85	1546	2.20 " "		3.39	1648
0.90	1613	2.25 " "		3.40 no spike	
0.95	1485	2.30 " "		3.45 " "	
0.998	1456	2.35 " "		3.47	1630
1.00 no spike		2.40 " "		3.50	1579

* Shockwave arrival 1.928 (measurement by Project 1.2)

TABLE C.6 (Cont.)

Velocity vs Time Tumbler 3 Tower 202 Elevation 1½ Ft
 Total Thermal Radiation 50 Cal/Cm² (from Project 8.3 Data)

Time (Secs)	Vel (Ft/Sec)	Time (Secs)	Vel (Ft/Sec)	Time (Secs)	Vel (Ft/Sec)
3.55	1667				
3.60 no spike					
3.614	1667				
3.65 no spike					
3.678	1786				
3.70	1648				
3.75 no spike					
3.78	1500				
3.80 no spike					
3.804	1531				
3.85	1724				
3.90 no spike					
3.904	1685				
3.948	1531				
3.95 no spike					
4.00 " "					

TABLE C.7

Velocity vs Time Tumbler 3 Tower 204 Elevation 54 Ft
 Total Thermal Radiation 34 Cal/Cm² (from Project 8.3 Data)

Time (Secs)	Vel (Ft/Sec)	Time (Secs)	Vel (Ft/Sec)	Time (Secs)	Vel (Ft/Sec)
-0.50	1124	1.008	1107	*2.50	1132
-0.45	1124	1.05	1176	2.55	2326
-0.40	1124	1.10	1149	2.60	1714
-0.35	1115	1.15	1176	2.648	1408
-0.30	1115	1.20	1149	2.65 no spike	
-0.25	1124	1.25 no spike		2.70	1357
-0.20	1124	1.266	1176	2.75	1370
-0.15	1124	1.30 no spike		2.80	1167
-0.10	1115	1.308	1158	2.85	1276
-0.05	1107	1.35	1167	2.90	1124
0.00	1463	1.40	1167	2.95	1276
0.05	1124	1.45	1167	3.00	1176
0.10	1115	1.50	1167	3.05	1158
0.15	1115	1.55	1149	3.10	1186
0.20	1107	1.60	1149	3.15	1149
0.25 no spike		1.65	1149	3.20	1176
0.26	1107	1.70	1141	3.25	1176
0.30	1141	1.75	1141	3.30	1149
0.35	1149	1.80	1141	3.35	1124
0.40	1141	1.85	1132	3.40	1107
0.45	1176	1.90	1141	3.45	1099
0.50	1176	1.95	1132	3.50	1099
0.55	1158	2.00	1132	3.55	1091
0.60	1234	2.05	1132	3.60	1091
0.65	1141	2.10	1141	3.65	1083
0.70	1107	2.15	1132	3.70	1083
0.75	1115	2.20	1141	3.75	1107
0.80	1124	2.25	1141	3.80	1091
0.85	1158	2.30	1132	3.85	1053
0.90	1234	2.35	1158	3.90	1068
0.95	1124	2.40	1141	3.95	1091
1.00 no spike		2.45	1132	4.00	1149

* Shockwave arrival 2.530 (measurement by Project 1.2)

TABLE C.8

Velocity vs Time Tumbler 3 Tower 204 Elevation 10 Ft
 Total Thermal Radiation 34 Cal/Cm² (from Project 8.3 Data)

Time (Secs)	Vel (Ft/Sec)	Time (Secs)	Vel (Ft/Sec)	Time (Secs)	Vel (Ft/Sec)
-0.50	1119	1.10	1149	2.70	1630
-0.45	1111	1.15	1154	2.75	1630
-0.40	1115	1.20	1145	2.80	1648
-0.35	1119	1.25	1158	2.85	1622
-0.30	1119	1.30	1158	2.90	1630
-0.25	1124	1.35	1141	2.95	1622
-0.20	1119	1.40	1163	3.00	1667
-0.15	1115	1.45	1154	3.05	1613
-0.10	1124	1.50	1141	3.10	1579
-0.05	1111	1.55	1149	3.15 no spike	
0.00 no spike		1.60	1145	3.154	1119
0.05	1124	1.65	1149	3.156	1948
0.10	1115	1.70	1158	3.20	1049
0.15	1115	1.75	1145	3.25	1087
0.20	1119	1.80	1149	3.30	1079
0.25	1119	1.85	1158	3.35	1103
0.30	1119	1.90	1149	3.40	1079
0.35	1128	1.95	1141	3.45	1056
0.40	1128	2.00	1158	3.50	1071
0.45	1119	2.05	1145	3.55	1034
0.50	1163	2.10	1163	3.60	1034
0.55	1111	2.15	1163	3.65	1034
0.60	1181	2.20	1158	3.70	1064
0.65	1145	2.25	1141	3.75	1049
0.70	1190	2.30	1141	3.80 no spike	
0.75	1136	2.35	1145	3.804	1103
0.80	1163	2.40	1145	3.85	1095
0.85	1210	2.45	1128	3.898	1145
0.90	1190	2.50	1154	3.90 no spike	
0.95	1224	*2.55 no spike		3.948	1186
1.00	1141	2.60	1351	3.95 no spike	
1.05	1119	2.65	1622	4.00	1034

* Shockwave arrival 2.553 (measurement by Project 1.2)

TABLE C.9

Velocity vs Time Tumbler 3 Tower 204 Elevation 1½ Ft
 Total Thermal Radiation 34 Cal/Cm² (from Project 8.3 Data)

Time (Secs)	Vel (Ft/Sec)	Time (Secs)	Vel (Ft/Sec)	Time (Secs)	Vel (Ft/Sec)
-0.50	1132	1.05	1266	2.606	1176
-0.45	1124	1.10	1245	2.65 no spike	
-0.40	1124	1.15	1224	2.652	1422
-0.35	1124	1.20	1322	2.70 no spike	
-0.30	1124	1.25	1214	2.704	1083
-0.25	1115	1.30	1255	2.75	1115
-0.20	1124	1.35	1276	2.80 no spike	
-0.15	1115	1.40	1234	2.802	1266
-0.10	1124	1.45	1266	2.85	1224
-0.05	1115	1.50	1266	2.90 no spike	
0.00 no spike		1.55	1266	2.902	1266
0.008	1124	1.60	1288	2.95	1224
0.05	1115	1.65	1310	3.00	1176
0.10	1124	1.70	1333	3.05	1195
0.15	1115	1.75	1299	3.10	1186
0.20	1132	1.80	1322	3.15	1141
0.25	1132	1.85	1299	3.20	1132
0.30	1132	1.90	1310	3.25	1099
0.35	1141	1.95	1299	3.30	1099
0.40	1141	2.00	1310	3.35	1099
0.45	1141	2.05	1266	3.40	1075
0.50	1167	2.10	1255	3.45	1068
0.55	1205	2.15	1266	3.50	1075
0.60	1167	2.20	1255	3.55	1091
0.65	1288	2.25	1310	3.60	1107
0.70 no spike		2.30	1266	3.65	1195
0.702	1141	2.35	1234	3.70	1075
0.75	1205	2.40	1224	3.75	1091
0.80	1186	2.45	1234	3.80	1083
0.85	1107	2.50	1205	3.85 no spike	
0.90	1333	2.55 no spike		3.852	1060
0.95	1255	*2.554	1060	3.90	1024
1.00	1276	*2.60 no spike		3.948	1158
				3.95 no spike	
				4.00	1124

* Shockwave arrival 2.560 (measurement by Project 1.2)

TABLE C.10

Velocity vs Time Tumbler 3 Tower 206 Elevation 54 Ft
 Total Thermal Radiation 27 Cal/Cm² (from Project 8.3 Data)

Time (Secs)	Vel (Ft/Sec)	Time (Secs)	Vel (Ft/Sec)	Time (Secs)	Vel (Ft/Sec)
-0.50	1115	1.05	1141	2.65	1124
-0.45	1115	1.10	1124	2.70	1124
-0.40	1124	1.15	1132	2.75	1124
-0.35	1115	1.20	1132	2.80	1132
-0.30	1124	1.25	1132	2.85	1124
-0.25	1115	1.30	1141	2.90	1124
-0.20	1115	1.35	1149	2.95	1124
-0.15	1124	1.40	1132	3.00	1132
-0.10	1115	1.45	1141	3.05	1132
-0.05	1115	1.50	1141	3.10	1124
0.00 no spike		1.55	1132	3.15	1124
0.002	1068	1.60	1124	3.20	1124
0.05	1115	1.65	1124	3.25	1124
0.10	1115	1.70	1124	3.30	1124
0.15	1107	1.75	1132	3.35	1115
0.20	1124	1.80	1124	3.40	1115
0.25	1107	1.85	1132	*3.45	1205
0.30	1115	1.90	1124	3.498	1090
0.35	1115	1.95	1132	3.50 no spike	
0.40	1115	2.00	1124	3.544	1255
0.45	1124	2.05	1124	3.55 No spike	
0.50	1115	2.10	1124	3.60	1245
0.55	1132	2.15	1124	3.648	1554
0.60	1132	2.20	1124	3.65 no spike	
0.65	1124	2.25	1132	3.698	1408
0.70	1132	2.30	1124	3.70 no spike	
0.75	1124	2.35	1124	3.75	1322
0.80	1132	2.40	1132	3.80 no spike	
0.85	1124	2.45	1124	3.802	1322
0.90	1132	2.50	1124	3.85	1288
0.95	1132	2.55	1132	3.90	1322
1.00	1132	2.60	1124	3.95	1234
				4.00	1357

* Shockwave arrival 3.430 (measurement by Project 1.2)

TABLE C.11

Velocity vs Time Tumbler 3 Tower 206 Elevation 10 Ft
 Total Thermal Radiation 27 Cal/Cm² (from Project 8.3 Data)

Time (Secs)	Vel (Ft/Sec)	Time (Secs)	Vel (Ft/Sec)	Time (Secs)	Vel (Ft/Sec)
-0.50	1119	1.15	1119	2.80	1119
-0.45	1119	1.20	1128	2.85	1149
-0.40	1119	1.25	1119	2.90	1141
-0.35	1124	1.30	1132	2.95	1107
-0.30	1115	1.35	1119	3.00	1099
-0.25	1119	1.40	1119	3.05	1119
-0.20	1119	1.45	1128	3.10	1107
-0.15	1124	1.50	1132	3.15	1107
-0.10	1124	1.55	1136	3.20	1124
-0.05	1119	1.60	1132	3.25	1149
0.00	1492	1.65	1115	3.30	1124
0.05	1136	1.70	1107	3.35	1099
0.10	1099	1.75	1167	3.40	1167
0.15	1091	1.80	1132	*3.45 no spike	
0.20	1149	1.85	1099	3.452	1357
0.25	1115	1.90	1181	3.50 no spike	
0.30	1103	1.95	1149	3.504	1422
0.35	1136	2.00	1119	3.55	1724
0.40	1163	2.05	1119	3.60 no spike	
0.45	1132	2.10	1107	3.602	1493
0.50	1124	2.15	1115	3.65 no spike	
0.55	1095	2.20	1136	3.652	1485
0.60	1124	2.25	1119	3.70	1935
0.65	1172	2.30	1115	3.75	1422
0.70	1158	2.35	1149	3.798	1214
0.75	1124	2.40	1115	3.80 no spike	
0.80	1128	2.45	1115	3.85 " "	
0.85	1124	2.50	1136	3.90 " "	
0.90	1149	2.55	1115	3.902	1136
0.95	1149	2.60	1115	3.95	1299
1.00	1119	2.65	1145	4.00	1210
1.05	1119	2.70	1128		
1.10	1145	2.75	1119		

* Shockwave arrival 3.450 (measurement by Project 1.2)

~~SECRET~~
TABLE C.12

Velocity vs Time Tumbler 3 Tower 206 Elevation 1½ Ft
Total Thermal Radiation 27 Cal/Cm² (from Project 8.3 Data)

Time (Secs)	Vel (Ft/Sec)	Time (Secs)	Vel (Ft/Sec)	Time (Secs)	Vel (Ft/Sec)
-0.50	1132	1.05	1195	2.65	1195
-0.45	1124	1.10	1205	2.70	1195
-0.40	1124	1.15	1176	2.75	1195
-0.35	1132	1.20	1186	2.80	1186
-0.30	1124	1.25	1176	2.85	1195
-0.25	1115	1.30	1176	2.90	1186
-0.20	1124	1.35	1186	2.95	1186
-0.15	1124	1.40	1176	3.00	1195
-0.10	1132	1.45	1167	3.05	1205
-0.05	1124	1.50	1176	3.10	1205
0.00 no spike		1.55	1186	3.15	1205
0.004	1045	1.60	1186	3.20	1214
0.05	1124	1.65	1167	3.25	1234
0.10	1124	1.70	1167	3.30	1205
0.15	1124	1.75	1176	3.35	1205
0.20	1132	1.80	1158	3.40	1224
0.25	1132	1.85	1176	3.446	1508
0.30	1132	1.90	1176	* 3.45 no spike	
0.35	1132	1.95	1176	3.494	1554
0.40	1132	2.00	1176	3.50 no spike	
0.45	1149	2.05	1186	3.544	1266
0.50	1149	2.10	1176	3.55 no spike	
0.55	1141	2.15	1167	3.60	1796
0.60	1158	2.20	1176	3.65 no spike	
0.65	1176	2.25	1176	3.654	1395
0.70	1205	2.30	1195	3.70	1186
0.75	1158	2.35	1195	3.75 no spike	
0.80	1141	2.40	1205	3.754	1538
0.85	1158	2.45	1186	3.80	1408
0.90	1224	2.50	1186	3.85	1224
0.95	1158	2.55	1195	3.90	1234
1.00	1214	2.60	1195	3.95	1310
				4.00	1195

* Shockwave arrival 3.455 (measurement by Project 1.2)

~~SECRET~~
TABLE C.13

Velocity vs Time Tumbler 4 Tower 200 Elevation 54 Ft*
Total Thermal Radiation Figure Not Given in Project 8.3 Data

Time (Secs)	Vel (Ft/Sec)	Time (Secs)	Vel (Ft/Sec)	Time (Secs)	Vel (Ft/Sec)
-0.50	1118	0.80 no spike		2.25 no spike	
-0.45	1118	0.85 " "		2.30 " "	
-0.40	1118	0.898	1809	2.35 " "	
-0.35	1118	0.90 no spike		2.40 " "	
-0.30	1118	0.95 " "		2.45 " "	
-0.25	1131	0.986	1292	2.50 " "	
-0.20	1118	1.00 no spike		2.55 " "	
-0.15	1118	1.05 " "		2.60 " "	
-0.10	1118	1.10 " "		2.65 " "	
-0.05	1118	1.15 " "		2.70 " "	
0.00	1327	1.186	1118	2.75 " "	
0.05	1144	1.20 no spike		2.80 " "	
0.10 no spike		1.208	1259	2.85 " "	
0.106	1485	1.25 no spike		2.90 " "	
0.148	1363	1.30 " "		2.95 " "	
0.15 no spike		1.35 " "		3.00 " "	
0.20 " "		1.40 " "		3.05 " "	
0.204	1184	1.45 " "		3.10 " "	
0.25	1157	1.50 " "		3.15 " "	
0.28	1877	1.55 " "		3.20 " "	
0.30 no spike		1.60 " "		3.25 " "	
0.35 " "		1.65 " "		3.30 " "	
0.384	1531	1.70 " "		3.35 " "	
0.40 no spike		1.75 " "		3.40 " "	
0.406	1990	1.80 " "		3.45 " "	
0.45 no spike		1.85 " "		3.50 " "	
0.498	1421	1.90 " "		3.55 " "	
0.50 no spike		1.93	2369	3.60 " "	
0.55 " "		1.95	2551	3.65 " "	
0.60 " "		2.00 no spike		3.70 " "	
0.65 " "		2.05 " "		3.75 " "	
0.676	1809	2.10 " "		3.80 " "	
0.70 no spike		2.15 " "		3.85 " "	
0.75 " "		2.20 " "		3.90 " "	
				3.95 " "	
				4.00 " "	

* Shockwave arrival time not given in Project 1.2 data.

TABLE C.14

Velocity vs Time Tumbler 4 Tower 200 Elevation 10 Ft
 Total Thermal Radiation Figure Not Given In Project 8,3 Data

Time (Secs)	Vel (Ft/Sec)	Time (Secs)	Vel (Ft/Sec)	Time (Secs)	Vel (Ft/Sec)
-0.50	1118	0.706	2031	1.65	1118
-0.45	1118	0.748	1990	1.70	1658
-0.40	1118	0.75 no spike		1.75 no spike	
-0.35	1131	0.80 " "		1.754	1106
-0.30	1118	0.802	1363	1.80 no spike	
-0.25	1118	0.85 no spike		1.804	1199
-0.20	1118	0.852	1184	1.85	1442
-0.15	1118	0.90	1144	1.90	2031
-0.10	1118	0.95 no spike		1.95 no spike	
-0.05	1118	0.954	1118	1.952	1555
0.00	1292	1.00	1199	2.00 no spike	
0.05 no spike		1.05	1118	2.002	1309
0.056	1631	1.10 no spike		2.05 no spike	
0.10	1463	1.114	3015	2.052	1485
0.15	1463	1.148	1199	2.10	1531
0.20 no spike		1.15 no spike		2.15 no spike	
0.202	1070	1.20 " "		2.152	1809
*0.25	1631	1.206	1170	2.198	1605
0.30	3980	1.248	2073	2.20 no spike	
0.35	1631	1.25 no spike		2.238	1686
0.40 no spike		1.30	2926	2.25 no spike	
0.402	2211	1.344	1531	2.30 " "	
0.45	1463	1.35 no spike		2.316	2488
0.50 no spike		1.40 " "		2.35 no spike	
0.502	2261	1.412	1199	2.352	5237
0.55 no spike		1.45 no spike		2.40 no spike	
0.552	2031	1.452	1093	2.404	1157
0.598	1421	1.50 no spike		2.446	1463
0.60 no spike		1.506	1842	2.45 no spike	
0.65 " "		1.546	1144	2.50	1485
0.654	2551	1.55 no spike		2.55	2031
0.70 no spike		1.60	1213	2.60	1809

* Shockwave arrival 0.225 (measurement by Project 1.2)

TABLE C.14 (Cont.)

Velocity vs Time Tumbler 4 Tower 200 Elevation 10 Ft
Total Thermal Radiation Figure Not Given In Project 8.3 Data

Time (Secs)	Vel (Ft/Sec)	Time (Secs)	Vel (Ft/Sec)	Time (Secs)	Vel (Ft/Sec)
2.65	2073	3.75 no spike			
2.70	2427	3.766	2926		
2.75 no spike		3.80 no spike			
2.766	1579	3.802	2369		
2.80	1842	3.85 no spike			
2.85 no spike		3.856	2843		
2.86	5237	3.896	1877		
2.896	1605	3.90 no spike			
2.90 no spike		3.95 " "			
2.944	4146	3.954	3827		
3.00 no spike		4.00	1144		
3.008	1555				
3.05	1746				
3.10 no spike					
3.106	1913				
3.15 no spike					
3.16	1309				
3.20	2261				
3.25 no spike					
3.268	1344				
3.30 no spike					
3.308	1555				
3.35 no spike					
3.362	1213				
3.40 no spike					
3.402	1382				
3.45 no spike					
3.462	1228				
3.50 no spike					
3.516	2211				
3.55 no spike					
3.566	2618				
3.60 no spike					
3.612	1990				
3.65 no spike					
3.66	5102				
3.698	1401				
3.70 no spike					

TABLE C.15

Velocity vs Time Tumbler 4 Tower 200 Elevation 1 1/2 Ft
 Total Thermal Radiation Figure Not Given In Project 8.3 Data

Time (Secs)	Vel (Ft/Sec)	Time (Secs)	Vel (Ft/Sec)	Time (Secs)	Vel (Ft/Sec)
-0.50	1137	0.752	4422	2.30 no spike	
-0.45	1137	0.80 no spike		2.35 " "	
-0.40	1124	0.834	3062	2.40 " "	
-0.35	1124	0.85 No spike		2.45 " "	
-0.30	1112	0.852	1730	2.50 " "	
-0.25	1124	0.90 no spike		2.55 " "	
-0.20	1112	0.95 " "		2.60 " "	
-0.15	1124	1.00 " "		2.65 " "	
-0.10	1124	1.05 " "		2.70 " "	
-0.05	1124	1.10 " "		2.75 " "	
0.00	1236	1.108	1354	2.80 " "	
0.05 no spike		1.15	4854	2.85 " "	
0.06	1336	1.20 no spike		2.90 " "	
0.10 no spike		1.25 " "		2.95 " "	
0.104	1087	1.30 " "		3.00 " "	
0.15 no spike		1.35 " "		3.05 " "	
0.172	1618	1.40 " "		3.10 " "	
0.20 no spike		1.45 " "		3.15 " "	
0.202	1354	1.50 " "		3.20 " "	
*0.25 no spike		1.55 " "		3.25 " "	
0.252	1645	1.60 " "		3.30 " "	
0.30 no spike		1.65 " "		3.35 " "	
0.35 " "		1.70 " "		3.40 " "	
0.398	1150	1.75 " "		3.45 " "	
0.40 no spike		1.80 " "		3.50 " "	
0.45 " "		1.85 " "		3.55 " "	
0.50 " "		1.90 " "		3.60 " "	
0.55 " "		1.95 " "		3.65 " "	
0.566	1236	2.00 " "		3.70 " "	
0.60 no spike		2.05 " "		3.75 " "	
0.65 " "		2.10 " "		3.80 " "	
0.70 " "		2.15 " "		3.85 " "	
0.702	4854	2.20 " "		3.90 " "	
0.75 no spike		2.25 " "		3.95 " "	
				4.00 " "	

* Shockwave arrival 0.228 (measurement by Project 1.2)

TABLE C.16

Velocity vs Time Tumbler 4 Tower 202 Elevation 54 Ft
Total Thermal Radiation Figure Not Given in Project 8.3 Data

Time (Secs)	Vel (Ft/Sec)	Time (Secs)	Vel (Ft/Sec)	Time (Secs)	Vel (Ft/Sec)
-0.50	1112	0.756	1432	1.85 no spike	
-0.45	1112	0.794	1372	1.90 " "	
-0.40	1112	0.80 no spike		1.95 " "	
-0.35	1112	0.85 " "		2.00 " "	
-0.30	1112	0.858	1064	2.05 " "	
-0.25	1112	0.90 no spike		2.10 " "	
-0.20	1112	0.914	1150	2.15 " "	
-0.15	1112	0.95 no spike		2.20 " "	
-0.10	1137	0.972	1137	2.25 " "	
-0.05	1124	1.00 no spike		2.30 " "	
0.00	1411	1.002	1112	2.35 " "	
0.05 no spike		1.05 no spike		2.40 " "	
0.06	1354	1.058	1076	2.45 " "	
0.10	1076	1.10	1112	2.50 " "	
0.15	1137	1.15	1206	2.55 " "	
0.20	1112	1.184	1042	2.60 " "	
0.25	1112	1.20 no spike		2.614	1672
0.30	1124	1.25 " "		2.65 no spike	
0.35	1192	1.256	2010	2.70 " "	
0.40 no spike		1.294	1076	2.75 " "	
0.406	1284	1.30 no spike		2.80 " "	
0.45	1087	1.322	1318	2.85 " "	
0.50 no spike		1.35 no spike		2.90 " "	
0.504	1137	1.40 " "		2.95 " "	
*0.55 no spike		1.45 " "		3.00 " "	
0.554	1701	1.50 " "		3.05 " "	
0.592	1137	1.55 " "		3.10 " "	
0.60 no spike		1.60 " "		3.15 " "	
0.65	1432	1.65 " "		3.20 " "	
0.70 no spike		1.70 " "		3.25 " "	
0.702	1099	1.75 " "		3.30 " "	
0.75 no spike		1.80 " "		3.35 " "	

* Shockwave arrival 0.508 (measurement by Project 1.2)

~~SECRET~~
TABLE C.16 (Cont.)

Velocity vs Time Tumbler 4 Tower 202 Elevation 54 Ft
Total Thermal Radiation Figure Not Given In Project 8.3 Data

Time (Secs)	Vel (Ft/Sec)	Time (Secs)	Vel (Ft/Sec)	Time (Secs)	Vel (Ft/Sec)
3.40 no spike					
3.45 " "					
3.50 " "					
3.55 " "					
3.60 " "					
3.65 " "					
3.70 " "					
3.75 " "					
3.80 " "					
3.85 " "					
3.90 " "					
3.95 " "					
4.00 " "					

~~RESTRICTED DATA~~
~~SECRET~~

~~SECRET~~

~~SECRET~~
TABLE C.17

Velocity vs Time Tumbler 4 Tower 202 Elevation 10 Ft
Total Thermal Radiation Figure Not Given In Project 8.3 Data

Time (Secs)	Vel (Ft/Sec)	Time (Secs)	Vel (Ft/Sec)	Time (Secs)	Vel (Ft/Sec)
-0.50	1118	0.90 no spike		2.50 no spike	
-0.45	1118	0.95 " "		2.55 " "	
-0.40	1118	1.00 " "		2.60 " "	
-0.35	1106	1.05 " "		2.65 " "	
-0.30	1118	1.10 " "		2.70 " "	
-0.25	1118	1.15 " "		2.75 " "	
-0.20	1118	1.20 " "		2.80 " "	
-0.15	1118	1.25 " "		2.85 " "	
-0.10	1118	1.30 " "		2.90 " "	
-0.05	1118	1.35 " "		2.95 " "	
0.00 no spike		1.40 " "		3.00 " "	
0.002	1223	1.45 " "		3.05 " "	
0.05 no spike		1.50 " "		3.10 " "	
0.10 " "		1.55 " "		3.15 " "	
0.15 " "		1.60 " "		3.20 " "	
0.20 " "		1.65 " "		3.25 " "	
0.25 " "		1.70 " "		3.30 " "	
0.30 " "		1.75 " "		3.35 " "	
0.35 " "		1.80 " "		3.40 " "	
0.40 " "		1.85 " "		3.45 " "	
0.45 " "		1.90 " "		3.50 " "	
*0.488	3827	1.95 " "		3.55 " "	
0.50 no spike		2.00 " "		3.60 " "	
0.55 " "		2.05 " "		3.65 " "	
0.584	1118	2.10 " "		3.70 " "	
0.60 no spike		2.15 " "		3.75 " "	
0.65 " "		2.20 " "		3.80 " "	
0.684	1327	2.25 " "		3.85 " "	
0.70 no spike		2.30 " "		3.90 " "	
0.75 " "		2.35 " "		3.95 " "	
0.80 " "		2.40 " "		4.00 " "	
0.85 " "		2.45 " "			

* Shockwave arrival 0.486 (measurement by Project 1.2)

TABLE C.18

Velocity vs Time Tumbler 4 Tower 202 Elevation $1\frac{1}{2}$ Ft
Total Thermal Radiation Figure Not Given In Project 8.3 Data

Time (Secs)	Vel (Ft/Sec)	Time (Secs)	Vel (Ft/Sec)	Time (Secs)	Vel (Ft/Sec)
-0.10	1093	1.00 no spike		2.50 no spike	
-0.05	1157	1.05 " "		2.55 " "	
0.00	1382	1.10 " "		2.60 " "	
0.05 no spike		1.15 " "		2.65 " "	
0.084	1382	1.20 " "		2.70 " "	
0.10	1157	1.206	1442	2.75 " "	
0.15	1170	1.25 no spike		2.80 " "	
0.198	1184	1.254	1913	2.85 " "	
0.20 no spike		1.30 no spike		2.90 " "	
0.248	1951	1.35 " "		2.95 " "	
0.25 no spike		1.40 " "		3.00 " "	
0.30	3209	1.45 " "		3.05 " "	
0.35	2369	1.50 " "		3.10 " "	
0.40	2487	1.55 " "		3.15 " "	
0.45	2487	1.60 " "		3.20 " "	
*0.50	1157	1.65 no spike		3.25 " "	
0.55 no spike		1.70 " "		3.30 " "	
0.56	1777	1.75 " "		3.35 " "	
0.60	3431	1.80 " "		3.40 " "	
0.65 no spike		1.85 " "		3.45 " "	
0.66	1309	1.90 " "		3.50 " "	
0.698	1118	1.95 " "		3.55 " "	
0.70 no spike		2.00 " "		3.60 " "	
0.75	1070	2.05 " "		3.65 " "	
0.78	2369	2.10 " "		3.70 " "	
0.80 no spike		2.15 " "		3.75 " "	
0.848	1344	2.20 " "		3.80 " "	
0.85 no spike		2.25 " "		3.85 " "	
0.90 " "		2.30 " "		3.90 " "	
0.904	1913	2.35 " "		3.95 " "	
0.948	3109	2.40 " "		4.00 " "	
0.95 no spike		2.45 " "			

* Shockwave arrival 0.483 (measurement by Project 1.2)

TABLE C.19

Velocity vs Time Tumbler 4 Tower 204 Elevation 54 Ft
 Total Thermal Radiation 57 Cal/Cm² (from Project 8.3 Data)

Time (Secs)	Vel (Ft/Sec)	Time (Secs)	Vel (Ft/Sec)	Time (Secs)	Vel (Ft/Sec)
-0.50	1150	1.15	1099	2.60 no spike	
-0.45	1124	1.20	1124	2.65 " "	
-0.40	1099	1.25	1099	2.70 " "	
-0.35	1112	1.30	1087	2.734	1076
-0.30	1112	1.35	1112	2.75 no spike	
-0.25	1099	1.40	1099	2.754	1064
-0.20	1124	*1.45	1567	2.80 no spike	
-0.15	1112	1.464	1164	2.85 " "	
-0.10	1112	1.50 no spike		2.90 " "	
-0.05	1112	1.55 " "		2.95 " "	
0.00	1112	1.60 " "		3.00 " "	
0.05 no spike		1.65 " "		3.05 " "	
0.054	1178	1.70 " "		3.10 " "	
0.10	1137	1.75 " "		3.15 " "	
0.15	1112	1.80 " "		3.20 " "	
0.20	1099	1.85 " "		3.25 " "	
0.25	1112	1.90 " "		3.30 " "	
0.30	1099	1.95 " "		3.35 " "	
0.35	1099	2.00 " "		3.40 " "	
0.40	1099	2.01	1053	3.412	1053
0.45	1112	2.05	1150	3.45 no spike	
0.50	1112	2.10	1064	3.50 " "	
0.55	1112	2.15 no spike		3.55 " "	
0.60	1112	2.20 " "		3.60 " "	
0.65	1112	2.204	1042	3.65 " "	
0.70	1099	2.25	1042	3.70 " "	
0.75	1112	2.30 no spike		3.75 " "	
0.80	1112	2.312	1053	3.80 " "	
0.85	1112	2.35	1042	3.85 " "	
0.90	1124	2.40 no spike		3.90 " "	
0.95	1112	2.434	1053	3.926	1053
1.00	1099	2.45 no spike		3.95	1042
1.05	1112	2.50 " "		3.99	1042
1.10	1112	2.55 " "		4.00 no spike	

* Shockwave arrival 1.431 (Measurement by Project 1.2)

TABLE C.20

Velocity vs Time Tumbler 4 Tower 204 Elevation 10 Ft
Total Thermal Radiation 57 Cal/Cm² (from Project 8.3 Data)

Time (Secs)	Vel (Ft/Sec)	Time (Secs)	Vel (Ft/Sec)	Time (Secs)	Vel (Ft/Sec)
-0.50	1137	1.20	1137	2.39	1076
-0.45	1124	1.25	1124	2.40 no spike	
-0.40	1112	1.30	1150	2.44	1137
-0.35	1112	1.35	1150	2.45 no spike	
-0.30	1124	1.40	1137	2.49	1076
-0.25	1112	*1.45 no spike		2.50 no spike	
-0.20	1124	1.462	1301	2.55 " "	
-0.15	1112	1.50	1336	2.558	1076
-0.10	1112	1.544	1124	2.60 no spike	
-0.05	1112	1.55 no spike		2.602	1076
0.00	1519	1.598	1336	2.65	1178
0.05	1112	1.60 no spike		2.70	1076
0.10	1124	1.65	1519	2.75 no spike	
0.15	1137	1.694	1392	2.752	1192
0.20	1124	1.70 no spike		2.798	1252
0.25	1150	1.75 " "		2.80 no spike	
0.30	1124	1.754	1496	2.85 " "	
0.35	1124	1.798	1252	2.86	1087
0.40	1112	1.80 no spike		2.898	1236
0.45	1137	1.85	1252	2.90 no spike	
0.50	1124	1.90 no spike		2.95 " "	
0.55	1112	1.904	1301	2.96	1496
0.60	1137	1.95	1301	2.998	1178
0.65	1124	2.00	1150	3.00 no spike	
0.70	1124	2.05 no spike		3.048	1301
0.75	1150	2.056	1112	3.05 no spike	
0.80	1112	2.10	1112	3.10 " "	
0.85	1112	2.15	1076	3.104	1192
0.90	1137	2.20	1137	3.15	1192
0.95	1137	2.25 no spike		3.20	1087
1.00	1137	2.262	1087	3.25 no spike	
1.05	1150	2.30 no spike		3.254	1076
1.10	1137	2.304	1150	3.30	1206
1.15	1137	2.35	1087	3.35	1164

* Shockwave arrival 1.431 (measurement by Project 1.2)

~~SECRET~~

TABLE C.20 (Cont.)

Velocity vs Time Tumbler 4 Tower 204 Elevation 10 Ft
Total Thermal Radiation 57 Cal/Cm² (from Project 8.3 Data)

Time (Secs)	Vel (Ft/Sec)	Time (Secs)	Vel (Ft/Sec)	Time (Secs)	Vel (Ft/Sec)
3.398	1206				
3.40 no spike					
3.45	1354				
3.50	1112				
3.55	1236				
3.60	1252				
3.65	1221				
3.70	1301				
3.75	1236				
3.80	1221				
3.85	1252				
3.90	1252				
3.95	1252				
4.00	1192				

~~SECRET~~

~~SECRET~~

~~SECRET~~

TABLE C.21

Velocity vs Time Tumbler 4 Tower 206 Elevation 54 Ft
Total Thermal Radiation 25 Cal/Cm² (from Project 8.3 Data)

Time (Secs)	Vel (Ft/Sec)	Time (Secs)	Vel (Ft/Sec)	Time (Secs)	Vel (Ft/Sec)
-0.50	1118	1.15	1118	2.80	1259
-0.45	1118	1.20	1118	2.85	1058
-0.40	1118	1.25	1118	2.90	1228
-0.35	1118	1.30	1118	2.95	1058
-0.30	1118	1.35	1106	3.00	1118
-0.25	1118	1.40	1106	3.05	1047
-0.20	1118	1.45	1118	3.10	1093
-0.15	1106	1.50	1118	3.15	1047
-0.10	1144	1.55	1118	3.20	1118
-0.05	1118	1.60	1118	3.25	1082
0.00 no spike		1.65	1118	3.30	1058
0.002	1036	1.70	1118	3.35	1058
0.05	1106	1.75	1118	3.40	1070
0.10	1106	1.80	1118	3.45	1070
0.15	1106	1.85	1118	3.50	1070
0.20	1106	1.90	1118	3.55	1047
0.25	1106	1.95	1118	3.60	1058
0.30	1106	2.00	1131	3.65	1047
0.35	1118	2.05	1131	3.70	1047
0.40	1118	2.10	1131	3.75	1036
0.45	1118	2.15	1144	3.80	1047
0.50	1136	2.20	1131	3.85	1026
0.55	1106	2.25	1131	3.90	1026
0.60	1118	2.30	1144	3.95	1058
0.65	1106	2.35	1144	4.00	1047
0.70	1106	2.40	1144	4.05	1106
0.75	1118	2.45	1131	4.10	1005
0.80	1118	2.50	1144	4.15	1070
0.85	1106	*2.55 no spike		4.20	1005
0.90	1118	2.552	1421	4.25	1036
0.95	1118	2.60	1213	4.30	1093
1.00	1106	2.65	1401	4.35	1015
1.05	1106	2.70	1047	4.40	1082
1.10	1118	2.75	1106	4.45	1026

* Shockwave arrival 2.537 (measurement by Project 1.2)

~~SECRET~~

~~SECRET~~

~~SECRET~~

TABLE C.21 (Cont.)

Velocity vs Time Tumbler 4 Tower 206 Elevation 54 Ft
Total Thermal Radiation 25 Cal/Cm² (from Project 8.3 Data)

Time (Secs)	Vel (Ft/Sec)	Time (Secs)	Vel (Ft/Sec)	Time (Secs)	Vel (Ft/Sec)
4.50	995	6.00	1036	7.75	1047
4.548	1047	6.05	1058	7.80	1047
4.55 no spike		6.10	1047	7.85	1047
4.60	1058	6.15	1047	7.90	1058
4.65	1070	6.20	1036	7.95	1047
4.70	1036	6.25	1047	8.00	1047
4.75 no spike		6.30	1047		
4.752	1070	6.35	1047		
4.80	1047	6.40	1047		
4.848	1118	6.45	1058		
4.85 no spike		6.50	1047		
4.90 " "		6.55	1058		
4.902	1421	6.60	1047		
4.95	1047	6.65	1058		
5.00	1036	6.70	1058		
5.05	1058	6.75	1058		
5.10	1047	6.80	1036		
5.148	1036	6.85	1058		
5.15 no spike		6.90	1058		
5.20	1026	6.95	1058		
5.25	1047	7.00	1058		
5.30	1070	7.05	1058		
5.35	1047	7.10	1058		
5.40	1093	7.15	1058		
5.45	1047	7.20	1058		
5.50	1058	7.25	1070		
5.55	1047	7.30	1058		
5.60	1047	7.35	1058		
5.65	1047	7.40	1058		
5.70	1047	7.45	1047		
5.75	1047	7.50	1058		
5.80	1047	7.55	1058		
5.85	1047	7.60	1047		
5.90	1047	7.65	1047		
5.95	1047	7.70	1047		

~~SECRET~~

~~CONFIDENTIAL~~

TABLE C.22

Velocity vs Time Tumbler 4 Tower 206 Elevation 10 Ft
 Total Thermal Radiation 25 Cal/Cm² (from Project 8.3 Data)

Time (Secs)	Vel (Ft/Sec)	Time (Secs)	Vel (Ft/Sec)	Time (Secs)	Vel (Ft/Sec)
-0.50	1124	1.15	1137	2.796	1053
-0.45	1118	1.20	1137	2.80 no spike	
-0.40	1118	1.25	1137	2.844	1064
-0.35	1124	1.30	1137	2.85 no spike	
-0.30	1124	1.35	1150	2.898	1053
-0.25	1118	1.40	1150	2.90 no spike	
-0.20	1124	1.45	1164	2.948	1042
-0.15	1124	1.50	1164	2.95 no spike	
-0.10	1118	1.55	1164	3.00	1042
-0.05	1118	1.60	1164	3.05	1064
0.00 no spike		1.65	1164	3.10	1087
0.002	1496	1.70	1150	3.15 no spike	
0.05	1124	1.75	1150	3.154	1053
0.10	1118	1.80	1150	3.20	1053
0.15	1124	1.85	1164	3.25	1064
0.20	1124	1.90	1150	3.28	1042
0.25	1124	1.95	1137	3.30 no spike	
0.30	1124	2.00	1137	3.33	1042
0.35	1124	2.05	1137	3.35 no spike	
0.40	1137	2.10	1150	3.40 " "	
0.45	1137	2.15	1137	3.45 " "	
0.50	1137	2.20	1150	3.50 " "	
0.55	1137	2.25	1137	3.55 " "	
0.60	1124	2.30	1150	3.60 " "	
0.65	1124	2.35	1150	3.65 " "	
0.70	1137	2.40	1137	3.70 " "	
0.75	1137	2.45	1150	3.75 " "	
0.80	1137	2.50	1150	3.80 " "	
0.85	1124	*2.55	1354	3.85 " "	
0.90	1124	2.60	1112	3.90 " "	
0.95	1137	2.65	1076	3.95 " "	
1.00	1124	2.70 no spike		4.00 " "	
1.05	1137	2.702	1284	4.05 " "	
1.10	1137	2.75	1076	4.10 " "	

* Shockwave arrival 2.537 (measurement by Project 1.2)

TABLE C.22 (Cont.)

Velocity vs Time Tumbler 4 Tower 206 Elevation 10 Ft
 Total Thermal Radiation 25 Cal/Cm² (from Project 8.3 Data)

Time (Secs)	Vel (Ft/Sec)	Time (Secs)	Vel (Ft/Sec)	Time (Secs)	Vel (Ft/Sec)
4.15 no spike		5.348	1042	7.00	1031
4.20 " "		5.35 no spike		7.05	1031
4.25 " "		5.40 " "		7.10	1020
4.278	1076	5.41	1031	7.15	1053
4.30 no spike		5.45	1020	7.20	1042
4.35 " "		5.50	1064	7.25	1042
4.392	1053	5.55	1020	7.30	1053
4.40 no spike		5.60	1042	7.35	1042
4.45 " "		5.65	1031	7.40	1031
4.452	1042	5.70	1031	7.45	1042
4.486	1042	5.75	1042	7.50	1031
4.50 no spike		5.798	1042	7.55	1031
4.542	1064	5.80 no spike		7.60	1031
4.55 no spike		5.85	1042	7.65	1031
4.60 " "		5.90	1042	7.70	1042
4.624	1042	5.95	1042	7.75	1031
4.65 no spike		6.00	1042	7.80	1042
4.662	1042	6.05	1020	7.85	1042
4.70	1053	6.10	1042	7.90	1053
4.75	1064	6.15	1042	7.95	1053
4.792	1042	6.20	1020	8.00	1053
4.80 no spike		6.25	1020		
4.85	1020	6.30	1020		
4.898	1053	6.35	1020		
4.90 no spike		6.40	1042		
4.95	1064	6.45	1031		
5.00	1031	6.50	1042		
5.03	1076	6.55	1042		
5.05 no spike		6.60	1042		
5.10 no spike		6.65	1042		
5.114	1970	6.70	1042		
5.15	1020	6.75	1053		
5.20	1042	6.80	1042		
5.25 no spike		6.85	1042		
5.27	1053	6.90	1042		
5.30 no spike		6.95	1031		
5.304	1031				

TABLE C.23

Velocity vs Time Tumbler 4 Tower 206 Elevation 1 1/2 Ft
Total Thermal Radiation 25 Cal/Cm² (from Project 8.3 Data)

Time (Secs)	Vel (Ft/Sec)	Time (Secs)	Vel (Ft/Sec)	Time (Secs)	Vel (Ft/Sec)
-0.50	1137	1.05	1268	2.65	1221
-0.45	1137	1.10	1268	2.70	1221
-0.40	1124	1.15	1284	2.75	1221
-0.35	1124	1.20	1268	2.80	1118
-0.30	1124	1.25	1268	2.85	1192
-0.25	1124	1.30	1252	2.90	1178
-0.20	1124	1.35	1268	2.95	1178
-0.15	1124	1.40	1268	3.00	1192
-0.10	1124	1.45	1268	3.05	1192
-0.05	1124	1.50	1268	3.10	1164
0.00 no spike		1.55	1268	3.15	1192
0.002	1112	1.60	1268	3.20	1178
0.05	1236	1.65	1268	3.25	1236
0.10	1252	1.70	1268	3.30	1178
0.15	1268	1.75	1268	3.35	1164
0.20	1268	1.80	1268	3.40	1150
0.25	1252	1.85	1268	3.45	1164
0.30	1252	1.90	1268	3.50	1124
0.35	1252	1.95	1252	3.55	1099
0.40	1252	2.00	1268	3.60	1087
0.45	1268	2.05	1268	3.65	1124
0.50	1268	2.10	1268	3.70	1112
0.55	1268	2.15	1268	3.75	1112
0.60	1268	2.20	1268	3.80	1124
0.65	1268	2.25	1268	3.85	1112
0.70	1284	2.30	1268	3.90	1099
0.75	1268	2.35	1268	3.95	1112
0.80	1268	2.40	1268	4.00	1099
0.85	1268	2.45	1268	4.05	1099
0.90	1268	2.50	1268	4.10	1112
0.95	1268	*2.55	1354	4.15	1124
1.00	1268	2.60	1268	4.20	1099

* Shockwave arrival 2.537 (measurement by Project 1.2)

~~SECRET~~

TABLE C.23 (Cont.)

Velocity vs Time Tumbler 4 Tower 206 Elevation $1\frac{1}{2}$ Ft
Total Thermal Radiation 25 Cal/Cm² (from Project 8.3 Data)

Time (Secs)	Vel (Ft/Sec)	Time (Secs)	Vel (Ft/Sec)	Time (Secs)	Vel (Ft/Sec)
4.25	1099	5.95	1124	7.65	1137
4.30	1124	6.00	1124	7.70	1124
4.35	1112	6.05	1124	7.75	1137
4.40	1112	6.10	1124	7.80	1124
4.45	1112	6.15	1137	7.85	1124
4.50	1099	6.20	1137	7.90	1124
4.55	1099	6.25	1137	7.95	1124
4.60	1124	6.30	1137	8.00	1137
4.65	1124	6.35	1150		
4.70	1124	6.40	1164		
4.75	1137	6.45	1150		
4.80	1124	6.50	1164		
4.85	1164	6.55	1150		
4.90	1192	6.60	1164		
4.95	1192	6.65	1150		
5.00	1164	6.70	1124		
5.05	1178	6.75	1137		
5.10	1178	6.80	1137		
5.15	1178	6.85	1150		
5.20	1178	6.90	1150		
5.25	1178	6.95	1137		
5.30	1137	7.00	1137		
5.35	1124	7.05	1137		
5.40	1137	7.10	1137		
5.45	1124	7.15	1150		
5.50	1137	7.20	1137		
5.55	1150	7.25	1137		
5.60	1150	7.30	1124		
5.65	1150	7.35	1124		
5.70	1164	7.40	1124		
5.75	1137	7.45	1124		
5.80	1124	7.50	1124		
5.85	1124	7.55	1137		
5.90	1137	7.60	1137		

~~SECRET~~
Security Information

~~RESTRICTED DATA~~

~~SECRET~~

TABLE C.24

Velocity vs Time Tumbler 4 Tower 208 Elevation 54 Ft
Total Thermal Radiation 15 Cal/Cm² (from Project 8.3 Data)

Time (Secs)	Vel (Ft/Sec)	Time (Secs)	Vel (Ft/Sec)	Time (Secs)	Vel (Ft/Sec)
-0.50	1131	1.15	1157	2.80	1170
-0.45	1118	1.20	1144	2.85	1170
-0.40	1118	1.25	1157	2.90	1170
-0.35	1106	1.30	1157	2.95	1157
-0.30	1118	1.35	1157	3.00	1157
-0.25	1131	1.40	1144	3.05	1157
-0.20	1118	1.45	1144	3.10	1144
-0.15	1106	1.50	1157	3.15	1157
-0.10	1131	1.55	1144	3.20	1157
-0.05	1118	1.60	1157	3.25	1157
0.00	1082	1.65	1157	3.30	1170
0.05	1144	1.70	1144	3.35	1157
0.10	1144	1.75	1157	3.40	1144
0.15	1157	1.80	1157	3.45	1157
0.20	1157	1.85	1157	3.50	1144
0.25	1144	1.90	1144	3.55	1144
0.30	1157	1.95	1144	3.60	1157
0.35	1144	2.00	1144	3.65	1157
0.40	1157	2.05	1157	3.70	1144
0.45	1157	2.10	1144	*3.75	1047
0.50	1157	2.15	1170	3.80	1036
0.55	1144	2.20	1157	3.848	1106
0.60	1157	2.25	1157	3.85 no spike	
0.65	1157	2.30	1157	3.90 " "	
0.70	1157	2.35	1170	3.906	1047
0.75	1157	2.40	1157	3.95	1047
0.80	1170	2.45	1157	4.00	1026
0.85	1144	2.50	1157	4.05 no spike	
0.90	1157	2.55	1170	4.054	1082
0.95	1157	2.60	1157	4.10 no spike	
1.00	1157	2.65	1157	4.104	1070
1.05	1157	2.70	1157	4.15	1118
1.10	1144	2.75	1170	4.20	1058

* Shockwave arrival 3.728 (measurement by Project 1.2)

~~SECRET~~

~~SECRET~~

~~SECRET~~
TABLE C.24 (Cont.)

Velocity vs Time Tumbler 4 Tower 208 Elevation 54 Ft
Total Thermal Radiation 15 Cal/Cm² (from Project 8.3 Data)

Time (Secs)	Vel (Ft/Sec)	Time (Secs)	Vel (Ft/Sec)	Time (Secs)	Vel (Ft/Sec)
4.25	1026	5.55	1070	6.65 no spike	
4.30	1058	5.596	1106	6.70 " "	
4.35	1058	5.60 no spike		6.712	1015
4.40	1058	5.62	1118	6.75	1015
4.45	1199	5.70 no spike		6.798	1058
4.50	1184	5.75	1070	6.80 no spike	
4.55	1184	5.796	1047	6.848	1026
4.60 no spike		5.80 no spike		6.85 no spike	
4.602	1093	5.842	1118	6.888	1047
4.65	1058	5.85 no spike		6.90 no spike	
4.698	1047	5.90	1047	6.95	1026
4.70 no spike		5.95	1047	7.00	1015
4.748	1047	5.996	1015	7.05	1015
4.80	1070	6.00 no spike		7.10 no spike	
4.85	1093	6.05	1036	7.102	1093
4.90	1058	6.096	1036	7.15	1026
4.95	1093	6.10 no spike		7.20	1026
5.00 no spike		6.148	1036	7.25	1015
5.002	1047	6.15 no spike		7.30 no spike	
5.05	1292	6.20	1070	7.302	1442
5.10 no spike		6.25 no spike		7.35	1015
5.102	1026	6.254	1026	7.40	1015
5.15 no spike		6.30 no spike		7.45	1015
5.156	1036	6.308	1047	7.50	1026
5.20	1047	6.35	1058	7.55	1026
5.25 no spike		6.40	1170	7.60	1026
5.252	1026	6.448	1058	7.65	1026
5.30 no spike		6.45 no spike		7.70	1026
5.308	1047	6.498	1036	7.75	1026
5.35	1058	6.50 no spike		7.80	1026
5.40	1036	6.55	1058	7.85	1015
5.448	1026	6.598	1058	7.90	1058
5.45 no spike		6.60 no spike		7.95	1026
5.50	1026	6.632	1184	8.00	1015

TABLE C.25

Velocity vs Time Tumbler 4 Tower 208 Elevation 10 Ft
 Total Thermal Radiation 15 Cal/Cm² (from Project 8.3 Data)

Time (Secs)	Vel (Ft/Sec)	Time (Secs)	Vel (Ft/Sec)	Time (Secs)	Vel (Ft/Sec)
-0.50	1124	1.10	1124	2.70	1112
-0.45	1112	1.15	1124	2.75	1124
-0.40	1124	1.20	1124	2.80	1124
-0.35	1112	1.25	1124	2.85	1124
-0.30	1112	1.30	1124	2.90	1112
-0.25	1124	1.35	1124	2.95	1124
-0.20	1112	1.40	1124	3.00	1124
-0.15	1112	1.45	1124	3.05	1124
-0.10	1124	1.50	1124	3.10	1112
-0.05	1112	1.55	1124	3.15	1112
0.00	1701	1.60	1137	3.20	1112
0.05	1112	1.65	1124	3.25	1112
0.10	1112	1.70	1112	3.30	1112
0.15	1124	1.75	1112	3.35	1112
0.20	1124	1.80	1124	3.40	1124
0.25	1112	1.85	1112	3.45	1124
0.30	1112	1.90	1124	3.50	1112
0.35	1124	1.95	1112	3.55	1124
0.40	1112	2.00	1124	3.60	1124
0.45	1124	2.05	1112	3.65	1124
0.50	1112	2.10	1124	3.70	1124
0.55	1124	2.15	1124	*3.746	1053
0.60	1112	2.20	1112	3.75 no spike	
0.65	1124	2.25	1112	3.80	1178
0.70	1112	2.30	1112	3.85	1268
0.75	1124	2.35	1124	3.90	1206
0.80	1124	2.40	1112	3.95	1064
0.85	1112	2.45	1112	4.00	1164
0.90	1112	2.50	1112	4.05	1064
0.95	1112	2.55	1124	4.10	1064
1.00	1112	2.60	1112	4.15	1087
1.05	1124	2.55	1124	4.20	1112

* Shockwave arrival 3.728 (measurement by Project 1.2)

~~SECRET~~
TABLE C.25 (Cont.)

Velocity vs Time Tumbler 4 Tower 208 Elevation 10 Ft
Total Thermal Radiation 15 Cal/Cm² (from Project 8.3 Data)

Time (Secs)	Vel (Ft/Sec)	Time (Secs)	Vel (Ft/Sec)	Time (Secs)	Vel (Ft/Sec)
4.25	1042	5.95	1053	7.60	1076
4.30	1053	5.998	1031	7.65	1076
4.35	1087	6.00 no spike		7.70	1076
4.40	1064	6.05	1031	7.75	1076
4.45	1087	6.10	1064	7.80	1064
4.50	1076	6.148	1064	7.85	1076
4.55	1076	6.15 no spike		7.90	1076
4.60	1076	6.20	1087	7.95	1064
4.65	1064	6.25	1064	8.00	1064
4.70	1076	6.30	1064		
4.75	1053	6.35	1112		
4.80	1064	6.40	1064		
4.85	1064	6.45	1064		
4.90	1064	6.50	1064		
4.95	1064	6.55	1064		
5.00	1076	6.60	1076		
5.05	1064	6.65	1064		
5.10	1064	6.70	1099		
5.15	1053	6.75	1064		
5.20	1076	6.80	1076		
5.25	1053	6.85 no spike			
5.30	1064	6.852	1064		
5.35	1031	6.90	1064		
5.40	1064	6.95	1076		
5.45	1042	7.00	1064		
5.50	1042	7.05	1064		
5.55	1042	7.10	1053		
5.598	1042	7.15	1076		
5.60 no spike		7.20	1064		
5.65	1087	7.25	1076		
5.70	1064	7.30	1064		
5.748	1053	7.35	1064		
5.75 no spike		7.40	1064		
5.80	1042	7.45	1064		
5.85	1053	7.50	1076		
5.90	1053	7.55	1076		

~~SECRET~~
TABLE C.26

Velocity vs Time Tumbler 4 Tower 208 Elevation 1½ Ft
Total Thermal Radiation 15 Cal/Cm² (from Project 8.3 Data)

Time (Secs)	Vel (Ft/Sec)	Time (Secs)	Vel (Ft/Sec)	Time (Secs)	Vel (Ft/Sec)
-0.50	1112	1.20	1124	2.90	1137
-0.45	1124	1.25	1112	2.95	1137
-0.40	1124	1.30	1124	3.00	1137
-0.35	1124	1.35	1124	3.05	1137
-0.30	1124	1.40	1112	3.10	1137
-0.25	1124	1.45	1124	3.15	1137
-0.20	1124	1.50	1124	3.20	1137
-0.15	1137	1.55	1124	3.25	1137
-0.10	1137	1.60	1112	3.30	1124
-0.05	1137	1.65	1112	3.35	1137
0.00	4234	1.70	1124	3.40	1137
0.05	1124	1.75	1124	3.45	1137
0.10	1124	1.80	1124	3.50	1137
0.15	1124	1.85	1112	3.55	1137
0.20	1124	1.90	1112	3.60	1137
0.25	1112	1.95	1124	3.65	1124
0.30	1112	2.00	1124	3.70	1124
0.35	1124	2.05	1124	*3.75	1284
0.40	1112	2.10	1124	3.80	1192
0.45	1112	2.15	1124	3.85	1301
0.50	1112	2.20	1112	3.90	1164
0.55	1124	2.25	1124	3.95	1178
0.60	1112	2.30	1124	4.00	1178
0.65	1124	2.35	1124	4.05	1164
0.70	1112	2.40	1124	4.10	1087
0.75	1124	2.45	1124	4.15	1137
0.80	1124	2.50	1124	4.20	1150
0.85	1124	2.55	1124	4.25	1137
0.90	1112	2.60	1124	4.30	1124
0.95	1112	2.65	1124	4.35	1112
1.00	1112	2.70	1124	4.40	1124
1.05	1124	2.75	1137	4.45	1150
1.10	1112	2.80	1137	4.50	1124
1.15	1112	2.85	1137	4.55	1124

* Shockwave arrival 3.729 (measurement by Project 1.2)

~~SECRET~~
TABLE C.26 (Cont)

Velocity vs Time Tumbler 4 Tower 208 Elevation 1½ Ft
Total Thermal Radiation 15 Cal/Cm² (from Project 8.3 Data)

Time (Secs)	Vel (Ft/Sec)	Time (Secs)	Vel (Ft/Sec)	Time (Secs)	Vel (Ft/Sec)
4.60	1137	6.45	1124		
4.65	1137	6.50	1150		
4.70	1137	6.55	1137		
4.75	1137	6.60	1137		
4.80	1137	6.65	1137		
4.85	1124	6.70	1124		
4.90	1124	6.75	1137		
4.95	1124	6.80	1124		
5.00	1124	6.85	1124		
5.05	1124	6.90	1124		
5.10	1112	6.95	1124		
5.15	1124	7.00	1112		
5.20	1137	7.05	1124		
5.25	1137	7.10	1124		
5.30	1099	7.15	1137		
5.35	1124	7.20	1124		
5.40	1124	7.25	1124		
5.45	1124	7.30	1124		
5.50	1112	7.35	1124		
5.55	1124	7.40	1124		
5.60	1099	7.45	1137		
5.65	1124	7.50	1124		
5.70	1099	7.55	1124		
5.75	1099	7.60	1137		
5.80	1099	7.65	1137		
5.85	1137	7.70	1124		
5.90	1112	7.75	1137		
5.95	1087	7.80	1150		
6.00	1124	7.85	1137		
6.05	1099	7.90	1137		
6.10	1112	7.95	1137		
6.15	1099	8.00	1137		
6.20	1137				
6.25	1137				
6.30	1137				
6.35	1137				
6.40	1150				

~~SECRET~~

~~RESTRICTED DATA~~

APPENDIX D

TUMBLER 3 AND 4 TABLES OF
ACOUSTIC VELOCITY VS TIME
FOR INTERVALS OF 50 MILLISECONDS
BEFORE SHOCK WAVE ARRIVAL

The velocity data in Appendix D may differ slightly from those of Appendix C as the former were extracted by tele-reader and IBM machine techniques by a professional computing company, whereas, for the latter the more conventional brute force method of a technician with a ruler was adopted. The author, however, has been unable to discover any major discrepancies.

~~SECRET~~
TABLE D.1

Velocity vs Time Tumbler 3 Tower 200 Elevation 54 Ft

Time (Secs)	Vel (Ft/Sec)	Time (Secs)	Vel (Ft/Sec)	Time (Secs)	Vel (Ft/Sec)
1.618	1123	1.638	1239	1.658	1181
1.620	1158	1.640	1239	1.660	1195
1.622 no spike		1.642	1229	1.662	1185
1.624 " "		1.644	1219	1.664	1200
1.626 " "		1.646	1234	1.666	1094
1.628 " "		1.648	1209	1.668 no spike	
1.630 " "		1.650	1209	*1.670 " "	
1.632 " "		1.652	1209	1.672 " "	
1.634	1145	1.654	1190	1.674	2702
1.636	1167	1.656	1214	1.676	1408

* Shockwave arrival 1.671 (measurement by Project 1.2)

TABLE D.2

Velocity vs Time Tumbler 3 Tower 200 Elevation 10 Ft

Time (Secs)	Vel (Ft/Sec)	Time (Secs)	Vel (Ft/Sec)	Time (Secs)	Vel (Ft/Sec)
1.654	1538	1.674 no spike		1.694	1421
1.656	1463	1.676 " "		1.696	1463
1.658 no spike		1.678	1449	1.698 no spike	
1.660 " "		1.680 no spike		1.700 " "	
1.662 " "		1.682	1612	*1.702 " "	
1.664	1724	1.684 no spike		1.704	1910
1.666 no spike		1.686	1818	1.706 no spike	
1.668	2222	1.688	1754	1.708	1470
1.670 no spike		1.690	1449	1.710 no spike	
1.672	1621	1.692	1714	1.712 " "	

* Shockwave arrival 1.702 (measurement by Project 1.2)

~~SECRET~~
TABLE D.3

Velocity vs Time Tumbler 3 Tower 200 Elevation 1 1/2 Ft

Time (Secs)	Vel (Ft/Sec)	Time (Secs)	Vel (Ft/Sec)	Time (Secs)	Vel (Ft/Sec)
1.660 no spike		1.680	1463	1.700	1587
1.662 " "		1.682	1515	1.702	1456
1.664 " "		1.684	1435	1.704	2097
1.666 " "		1.686	1421	1.706 no spike	
1.668 " "		1.688	1428	*1.708 " "	
1.670 " "		1.690	1554	1.710	1229
1.672 " "		1.692	1492	1.712	1075
1.674 " "		1.694	1477	1.714 no spike	
1.676 " "		1.696	1554	1.716	1304
1.678	1587	1.698	1562	1.718 no spike	

* Shockwave arrival 1.708 (measurement by Project 1.2)

TABLE D.4

Velocity vs Time Tumbler 3 Tower 202 Elevation 54 Ft

Time (Secs)	Vel (Ft/Sec)	Time (Secs)	Vel (Ft/Sec)	Time (Secs)	Vel (Ft/Sec)
1.844	1149	1.864	1149	1.884 no spike	
1.846	1136	1.866	1127	1.886 " "	
1.848	1132	1.868	1149	1.888	2189
1.850	1136	1.870	1127	1.890 no spike	
1.852	1136	1.872	1153	*1.892	1554
1.854	1162	1.874	1136	1.894 no spike	
1.856	1149	1.876	1132	1.896 " "	
1.858	1149	1.878	1127	1.898	1333
1.860	1149	1.880 no spike		1.900 no spike	
1.862	1153	1.882 " "		1.902	1271

* Shockwave arrival 1.893 (measurement by Project 1.2)

~~SECRET~~
~~CONFIDENTIAL~~
TABLE D.5

Velocity vs Time Tumbler 3 Tower 202 Elevation 10 Ft

Time (Secs)	Vel (Ft/Sec)	Time (Secs)	Vel (Ft/Sec)	Time (Secs)	Vel (Ft/Sec)
1.870	1214	1.890	1195	1.910	1185
1.872	1219	1.892	1195	1.912	1181
1.874	1219	1.894	1181	1.914	1119
1.876	1250	1.896	1171	1.916	1115
1.878	1250	1.898	1200	1.918	1162
1.880	1229	1.900	1171	1.920	1293
1.882	1265	1.902	1181	*1.922	1181
1.884	1234	1.904	1149	1.924	1185
1.886	1224	1.906	1209	1.926	1149
1.888	1239	1.908	1149	1.928	1158

* Shockwave arrival 1.922 (measurement by Project 1.2)

TABLE D.6

Velocity vs Time Tumbler 3 Tower 202 Elevation 1½ Ft

Time (Secs)	Vel (Ft/Sec)	Time (Secs)	Vel (Ft/Sec)	Time (Secs)	Vel (Ft/Sec)
1.880	1339	1.900 no spike		1.920 no spike	
1.882	1327	1.902	1604	1.922 " "	
1.884	1321	1.904	1657	1.924	1315
1.886	1333	1.906	1477	1.926 no spike	
1.888 no spike		1.908	1463	*1.928	1315
1.890	2040	1.910	1442	1.930 no spike	
1.892 no spike		1.912	1149	1.932 " "	
1.894 " "		1.914 no spike		1.934 " "	
1.896 " "		1.916	1287	1.936 " "	
1.898 " "		1.918 no spike		1.938 " "	

* Shockwave arrival 1.928 (measurement by Project 1.2)

~~CONFIDENTIAL DATA~~

~~SECRET~~
~~CONFIDENTIAL~~

TABLE D.7

Velocity vs Time Tumbler 3 Tower 204 Elevation 54 Ft

Time (Secs)	Vel (Ft/Sec)	Time (Secs)	Vel (Ft/Sec)	Time (Secs)	Vel (Ft/Sec)
2.474	1127	2.494	1132	2.514	1132
2.476	1136	2.496	1127	2.516	1136
2.478	1132	2.498	1132	2.518	1132
2.480	1136	2.500	1127	2.520	1136
2.482	1127	2.502	1136	2.522	1132
2.484	1140	2.504	1136	2.524	1315
2.486	1136	2.506	1127	2.526	no spike
2.488	1127	2.508	1136	2.528	2400
2.490	1132	2.510	1123	*2.530	no spike
2.492	1127	2.512	1136	2.532	2189

* Shockwave arrival 2.530 (measurement by Project 1.2)

TABLE D.8

Velocity vs Time Tumbler 3 Tower 204 Elevation 10 Ft

Time (Secs)	Vel (Ft/Sec)	Time (Secs)	Vel (Ft/Sec)	Time (Secs)	Vel (Ft/Sec)
2.504	1153	2.524	1149	2.544	no spike
2.506	1149	2.526	1149	2.546	1063
2.508	1153	2.528	no spike	2.548	no spike
2.510	1149	2.530	1287	2.550	" "
2.512	1153	2.532	no spike	*2.552	" "
2.514	1153	2.534	" "	2.554	" "
2.516	1149	2.536	1818	2.556	" "
2.518	1153	2.538	no spike	2.558	" "
2.520	1149	2.540	" "	2.560	" "
2.522	1149	2.542	" "	2.562	" "

* Shockwave arrival 2.553 (measurement by Project 1.2)

TABLE D.9

Velocity vs Time Tumbler 3 Tower 204 Elevation 1½ Ft

Time (Secs)	Vel (Ft/Sec)	Time (Secs)	Vel (Ft/Sec)	Time (Secs)	Vel (Ft/Sec)
2.512	1209	2.532	1195	2.552	no spike
2.514	1209	2.534	1190	2.554	" "
2.516	1195	2.536	1190	2.556	1060
2.518	1200	2.538	1181	2.558	no spike
2.520	1204	2.540	1209	*2.560	" "
2.522	1195	2.542	no spike	2.562	1796
2.524	1204	2.544	" "	2.564	1775
2.526	1200	2.546	1463	2.566	no spike
2.528	1195	2.548	no spike	2.568	" "
2.530	1195	2.550	1111	2.570	" "

* Shockwave arrival 2.560 (measurement by Project 1.2)

TABLE D.10

Velocity vs Time Tumbler 3 Tower 206 Elevation 54 Ft

Time (Secs)	Vel (Ft/Sec)	Time (Secs)	Vel (Ft/Sec)	Time (Secs)	Vel (Ft/Sec)
3.372	1127	3.392	1123	3.412	1115
3.374	1115	3.394	1115	3.414	1123
3.376	1123	3.396	1115	3.416	1123
3.378	1127	3.398	1123	3.418	1115
3.380	1123	3.400	1132	3.420	1123
3.382	1119	3.402	1119	3.422	no spike
3.384	1119	3.404	1119	3.424	1293
3.386	1123	3.406	1115	3.426	no spike
3.388	1119	3.408	1115	3.428	" "
3.390	1123	3.410	1127	*3.430	2521

* Shockwave arrival 3.430 (measurement by Project 1.2)

~~SECRET~~
TABLE D.11

Velocity vs Time Tumbler 3 Tower 206 Elevation 10 Ft

Time (Secs)	Vel (Ft/Sec)	Time (Secs)	Vel (Ft/Sec)	Time (Secs)	Vel (Ft/Sec)	
3.402	1127	3.422	1136	3.442 no spike	1321	
3.404	1127	3.424	1140	3.444		
3.406	1123	3.426	1119	3.446 no spike		
3.408	1127	3.428	1140	3.448 " "		
3.410	1132	3.430 no spike		*3.450 " "		
3.412	1127	3.432	1666	3.452 " "		
3.414	1140	3.434 no spike		3.454		1401
3.416	1127	3.436	1507	3.456		1149
3.418	1145	3.438 no spike		3.458 no spike		
3.420	1127	3.440	1595	3.460		1363
* Shockwave arrival 3.450 (measurement by Project 1.2)						

TABLE D.12

Velocity vs Time Tumbler 3 Tower 206 Elevation 1 1/2 Ft

Time (Secs)	Vel (Ft/Sec)	Time (Secs)	Vel (Ft/Sec)	Time (Secs)	Vel (Ft/Sec)	
3.406	1224	3.426	1219	3.446 no spike	1492	
3.408	1224	3.428	1214	3.448		
3.410	1224	3.430	1214	3.450 no spike		
3.412	1219	3.432	1234	3.452 " "		
3.414	1209	3.434 no spike		*3.454 " "		
3.416	1239	3.436	1176	3.456 " "		
3.418	1229	3.438 no spike		3.458		1204
3.420	1224	3.440 " "		3.460		1388
3.422	1229	3.442	2439	3.462 no spike		
3.424	1250	3.444	1200	3.464 " "		
* Shockwave arrival 3.455 (measurement by Project 1.2)						

TABLE D.13

Velocity vs Time Tumbler 4 Tower 200 Elevation 1 1/2 Ft

Time (Secs)	Vel (Ft/Sec)	Time (Secs)	Vel (Ft/Sec)	Time (Secs)	Vel (Ft/Sec)
0.180 no spike		0.200	1137	0.220 no spike	
0.182 " "		0.202 no spike		0.222 " "	
0.184 " "		0.204	1335	0.224 " "	
0.186	3372	0.206 no spike		0.226	4627
0.188 no spike		0.208	1519	*0.228 no spike	
0.190	5852	0.210 no spike		0.230	4422
0.192 no spike		0.212 " "		0.232	1344
0.194 " "		0.214 " "		0.234 no spike	
0.196	3826	0.216	4326	0.236	1381
0.198 no spike		0.218 no spike		0.238 no spike	

* Shockwave arrival 0.228 (measurement by Project 1.2)

TABLE D.14

Velocity vs Time Tumbler 4 Tower 202 Elevation 54 Ft

Time (Secs)	Vel (Ft/Sec)	Time (Secs)	Vel (Ft/Sec)	Time (Secs)	Vel (Ft/Sec)
0.460	1206	0.480	1105	0.500 no spike	
0.462	1184	0.482	1117	0.502 " "	
0.464	1150	0.484	1243	0.504	1117
0.466	1130	0.486	1267	0.506	1137
0.468	1093	0.488	1309	*0.508	1130
0.470	1137	0.490	1283	0.510	1156
0.472	1206	0.492	1191	0.512	1220
0.474	1251	0.494	1130	0.514	1220
0.476	1267	0.496	1087	0.516 no spike	
0.478	1198	0.498 no spike		**0.518	1507

* Shockwave arrival 0.508 (measurement by Project 1.2)
** Shockwave arrival 0.5182 (measurement by Project 1.4)

~~SECRET~~
TABLE D.15

Velocity vs Time Tumbler 4 Tower 202 Elevation 1½ Ft

Time (Secs)	Vel (Ft/Sec)	Time (Secs)	Vel (Ft/Sec)	Time (Secs)	Vel (Ft/Sec)
0.432	2551	0.454	2341	0.476	2618
0.434	2456	0.456	2584	0.478	2689
0.436	3372	0.458	2618	0.480 no spike	
0.438	2618	0.460	2518	*0.482	2653
0.440	2010	0.462	2618	*0.484	1372
0.442	2072	0.464	2369	0.486 no spike	
0.444	2369	0.466	2802	0.488 " "	
0.446	1932	0.468	2163	0.490 " "	
0.448	2426	0.470	2313	0.492 " "	
0.450	2235	0.472	2487	**0.494 " "	
0.452	2426	0.474	2456		

* Shockwave arrival 0.483 (measurement by Project 1.2)
** Shockwave arrival 0.4941 (measurement by Project 1.4)

TABLE D.16

Velocity vs Time Tumbler 4 Tower 204 Elevation 54 Ft

Time (Secs)	Vel (Ft/Sec)	Time (Secs)	Vel (Ft/Sec)	Time (Secs)	Vel (Ft/Sec)
1.382	1117	1.402	1105	1.422	1111
1.384	1117	1.404	1124	1.424	1137
1.386	1111	1.406	1099	1.426	1117
1.388	1111	1.408	1111	1.428	1124
1.390	1105	1.410	1105	*1.430	1111
1.392	1130	1.412	1124	*1.432	1745
1.394	1117	1.414	1111	**1.434 no spike	
1.396	1124	1.416	1124	1.436	4738
1.398	1117	1.418	1177	1.438	1877
1.400	1117	1.420	1093	1.440 no spike	

* Shockwave arrival 1.431 (measurement by Project 1.2)
** Shockwave arrival 1.4343 (measurement by Project 1.4)

TABLE D.17

Velocity vs Time Tumbler 4 Tower 204 Elevation 10 Ft

Time (Secs)	Vel (Ft/Sec)	Time (Secs)	Vel (Ft/Sec)	Time (Secs)	Vel (Ft/Sec)
1.382	1143	1.402	1137	1.422	2313
1.384	1137	1.404	1170	1.424	no spike
1.386	1156	1.406	1137	1.426	" "
1.388	1124	1.408	1163	1.428	9476
1.390	1163	1.410	1137	1.430	no spike
1.392	1130	1.412	1156	*1.432	" "
1.394	1156	1.414	1150	**1.434	" "
1.396	1156	1.416	1381	1.436	3491
1.398	1163	1.418	no spike	1.438	no spike
1.400	1150	1.420	" "	1.440	" "

* Shockwave arrival 1.431 (measurement by Project 1.2)
 ** Shockwave arrival 1.4343 (measurement by Project 1.4)

TABLE D.18

Velocity vs Time Tumbler 4 Tower 206 Elevation 54 Ft

Time (Secs)	Vel (Ft/Sec)	Time (Secs)	Vel (Ft/Sec)	Time (Secs)	Vel (Ft/Sec)
2.490	1137	2.510	1143	2.530	1130
2.492	1137	2.512	1130	2.532	1137
2.494	1143	2.514	1130	2.534	1130
2.496	1124	2.516	1130	*2.536	1130
2.498	1130	2.518	1124	2.538	1130
2.500	1137	2.520	1130	2.540	no spike
2.502	1137	2.522	1150	**2.542	" "
2.504	1130	2.524	1058	2.544	1326
2.506	1137	2.526	1156	2.546	no spike
2.508	1130	2.528	1191	2.548	1267

* Shockwave arrival 2.537 (measurement by Project 1.2)
 ** Shockwave arrival 2.5421 (measurement by Project 1.4)

TABLE D.19

Velocity vs Time Tumbler 4 Tower 206 Elevation 10 Ft

Time (Secs)	Vel (Ft/Sec)	Time (Secs)	Vel (Ft/Sec)	Time (Secs)	Vel (Ft/Sec)
2.488	1156	2.508	1156	2.528	no spike
2.490	1156	2.510	1143	2.530	1191
2.492	1156	2.512	1150	2.532	no spike
2.494	1156	2.514	1150	2.534	1353
2.496	1150	2.516	1143	*2.536	no spike
2.498	1143	2.518	1156	2.538	" "
2.500	1156	2.520	1156	2.540	" "
2.502	1143	2.522	2094	**2.542	1137
2.504	1150	2.524	no spike	2.544	no spike
2.506	1150	2.526	1069	2.546	1170

* Shockwave arrival 2.537 (measurement by Project 1.2)
 ** Shockwave arrival 2.5432 (measurement by Project 1.4)

TABLE D.20

Velocity vs Time Tumbler 4 Tower 206 Elevation 1 1/2 Ft

Time (Secs)	Vel (Ft/Sec)	Time (Secs)	Vel (Ft/Sec)	Time (Secs)	Vel (Ft/Sec)
2.488	1275	2.508	1275	2.528	no spike
2.490	1251	2.510	1267	2.530	" "
2.492	1267	2.512	1275	2.532	" "
2.494	1267	2.514	1259	2.534	" "
2.496	1275	2.516	1267	*2.536	" "
2.498	1275	2.518	1259	2.538	1421
2.500	1259	2.520	1275	2.540	1496
2.502	1259	2.522	2518	**2.542	no spike
2.504	1267	2.524	no spike	2.544	1283
2.506	1251	2.526	" "	2.546	1267

* Shockwave arrival 2.537 (measurement by Project 1.2)
 ** Shockwave arrival 2.5424 (measurement by Project 1.4)

TABLE D.21

Velocity vs Time Tumbler 4 Tower 208 Elevation 54 Ft

Time (Secs)	Vel (Ft/Sec)	Time (Secs)	Vel (Ft/Sec)	Time (Secs)	Vel (Ft/Sec)
3.680	1150	3.700	1163	3.720	1150
3.682	1150	3.702	1150	3.722	1150
3.684	1150	3.704	1156	3.724 no spike	
3.686	1150	3.706	1163	3.726	2763
3.688	1163	3.708	1156	*3.728 no spike	
3.690	1150	3.710	1156	3.730	1363
3.692	1163	3.712	1156	**3.732 no spike	
3.694	1156	3.714	1177	3.734 " "	
3.696	1156	3.716	1137	3.736 " "	
3.698	1156	3.718	1150	3.738 " "	

* Shockwave arrival 3.728 (measurement by Project 1.2)
 ** Shockwave arrival 3.7332 (measurement by Project 1.4)

TABLE D.22

Velocity vs Time Tumbler 4 Tower 208 Elevation 10 Ft

Time (Secs)	Vel (Ft/Sec)	Time (Secs)	Vel (Ft/Sec)	Time (Secs)	Vel (Ft/Sec)
3.680	1137	3.700	1130	3.720 no spike	
3.682	1117	3.702	1124	3.722	4234
3.684	1124	3.704	1130	3.724 no spike	
3.686	1124	3.706	1117	3.726 " "	
3.688	1124	3.708	1124	*3.728 " "	
3.690	1130	3.710	1124	3.730 " "	
3.692	1130	3.712	1124	3.732	1213
3.694	1130	3.714	1496	**3.734	1275
3.696	1124	3.716	1093	3.736	1236
3.698	1130	3.718 no spike		3.738	1111

* Shockwave arrival 3.728 (measurement by Project 1.2)
 ** Shockwave arrival 3.7350 (measurement by Project 1.4)

Velocity vs Time Tumbler 4 Tower 208 Elevation 1½ Ft

Time (Secs)	Vel (Ft/Sec)	Time (Secs)	Vel (Ft/Sec)	Time (Secs)	Vel (Ft/Sec)
3.680	1150	3.700	1137	3.720	5378
3.682	1130	3.702	1137	3.722	no spike
3.684	1130	3.704	1143	3.724	" "
3.686	1137	3.706	1137	3.726	" "
3.688	1130	3.708	1137	3.728	" "
3.690	1143	3.710	1143	*3.730	1592
3.692	1130	3.712	1530	3.732	1391
3.694	1150	3.714	no spike	**3.734	1317
3.696	1137	3.716	6862	3.736	1363
3.698	1143	3.718	no spike	3.738	1259

* Shockwave arrival 3.729 (measurement by Project 1.2)
 ** Shockwave arrival 3.7346 (measurement by Project 1.4)

~~SECRET~~
BIBLIOGRAPHY

1. Bergman, L., Der Ultraschall, Bell: London, 1938
2. Broida, T.R., Broido, A., Willoughby, A.B., Air Temperatures in the Vicinity of a Nuclear Detonation, Armed Forces Special Weapons Project, Operation Tumbler, Project 8.2, WT-542. Secret, SI, RD.
3. Brunt, D., Physical and Dynamical Meteorology, Cambridge: London, 1944.
4. Doll, E.B., Air Pressure vs Time and Distance, Armed Forces Special Weapons Project, Operation Tumbler, Project 1.2, WT-512. Secret, SI, RD.
5. Marciano, J.J., Temperatures in the Vicinity of an Atomic Explosion, USNEL Internal Memorandum Number 8, Secret, SI, March 1952.
6. Schilling, H.K., Drumheller, C.E., Nyborg, W.L., Thorpe, H.A., On Micrometeorology, American Journal of Physics, V. 14, 6, November-December 1946, pp 343-353.
7. Vigoureux, P., Ultrasonics, Wiley: New York, 1951.
8. The Effects of Atomic Weapons, Los Alamos Scientific Laboratory, September 1950.

~~SECRET~~
~~SECRET~~

DISTRIBUTION

Copy No.

ARMY ACTIVITIES

Asst. Chief of Staff, G-2, D/A, Washington 25, D. C.	1
Asst. Chief of Staff, G-3, D/A, Washington 25, D. C. ATTN: DACofS, G-3, (RR&SW)	2
Asst. Chief of Staff, G-4, D/A, Washington 25, D. C.	3
Chief of Ordnance, D/A, Washington 25, D. C. ATTN: ORDMX-AR	4
Chief Signal Officer, D/A, P&O Div., Washington 25, D. C. ATTN: SIGOP	5- 7
The Surgeon General, D/A, Washington 25, D. C. ATTN: Chairman, Medical R&D Board	8- 10
Chief Chemical Officer, D/A, Washington 25, D. C.	11- 12
Chief of Engineers, D/A, Military Construction Division, Protective Construction Branch, Washington 25, D. C. ATTN: ENGBE	13
Chief of Engineers, D/A, Civil Works Division, Washington, 25, D. C. ATTN: Engineering Division, Structural Branch	14
The Quartermaster General, CBR, Liaison Office, Research and Development Division, Washington 25, D. C.	15- 16
Chief of Transportation, D/A, Washington 25, D. C. ATTN: Military Planning and Intelligence	17
Chief, Army Field Forces, Ft. Monroe, Va.	18- 21
Army Field Forces Board #1, Ft. Pragg, N. C.	22
Army Field Forces Board #2, Ft. Knox, Ky.	23
Army Field Forces Board #4, Ft. Bliss, Tex.	24
Commanding General, First Army, Governor's Island, New York 4, N. Y. ATTN: ACofS, G-4	25- 26
Commanding General, Second Army, Ft. George G. Meade, Md. ATTN: AIAME	27
Commanding General, Second Army, Ft. George G. Meade, Md. ATTN: AIACM	28
Commanding General, Third Army, Ft. McPherson, Ga. ATTN: ACofS, G-3	29- 30
Commanding General, Fourth Army, Ft. Sam Houston, Tex. ATTN: G-3 Section	31- 32
Commanding General, Fifth Army, 1660 E. Hyde Park Blvd., Chicago 15, Ill. ATTN: ALFEN	33
Commanding General, Fifth Army, 1660 E. Hyde Park Blvd., Chicago 15, Ill. ATTN: ALFOR	34
Commanding General, Fifth Army, 1660 E. Hyde Park Blvd., Chicago 15, Ill. ATTN: ALFMD-O	35- 38
Commanding General, Fifth Army, 1660 E. Hyde Park Blvd., Chicago 15, Ill. ATTN: ALFBQ	39
Commanding General, Sixth Army, Presidio of San Francisco, Calif. ATTN: AMGCT-4	40
Commander-in-Chief, European Command, APO 403, c/o PM, New York, N. Y.	41

DISTRIBUTION (Continued)

Copy No.

Commander-in-Chief, U. S. Army Europe, APO 403, c/o PM, New York, N. Y. ATTN: OPOT Division Combat Dev. Branch	42- 43
Commander-in-Chief, Far East Command, APO 500, c/o PM, San Francisco, Calif. ATTN: ACofS, G-3	44- 48
Commanding General, U. S. Army Alaska, APO 942, c/o PM, Seattle, Wash.	49
Commanding General, U. S. Army Caribbean, APO 834, c/o PM, New Orleans, La. ATTN: CG, USARCARIB	50
Commanding General, U. S. Army Carbbbean, APO 834, c/o PM, New Orleans, La. ATTN: CG, USARFANT	51
Commanding General, U. S. Army Caribbean, APO 834, c/c PM, New Orleans, La. ATTN: Cml Off, USARCARIB	52
Commanding General, U. S. Army Caribbean, APO 834, c/o PM, New Orleans, La. ATTN: Surgeon, USARCARIB	53
Commanding General, U. S. Army Pacific, APO 958, c/o PM, San Francisco, Calif. ATTN: Cml Off	54- 55
Commanding General, Trieste U. S. Troops, APO 209, c/o PM, New York, N. Y. ATTN: ACofS, G-3	56
Commandant, Command and General Staff College, Ft. Leaven- worth, Kan. ATTN: ALLIS(AS)	57- 58
Commandant, The Infantry School, Ft. Benning, Ga. ATTN: C.D.S.	59- 60
Commandant, The Artillery School, Ft. Sill, Okla.	61
Commandant, The AA&GM Branch, The Artillery School, Ft. Bliss, Tex.	62
Commandant, The Armored School, Ft. Knox, Ky. ATTN: Classified Document Section, Evaluation and Research Division	63- 64
Commanding General, Medical Field Service School, Brooke Army Medical Center, Ft. Sam Houston, Tex.	65
Commandant, Army Medical Service Graduate School, Walter Reed Army Medical Center, Washington 25, D. C. ATTN: Dept. of Biophysics	66
The Superintendent, U. S. Military Academy, West Point, N. Y. ATTN: Professor of Ordnance	67- 68
Commanding General, The Transportation Center and Ft. Eustis, Ft. Eustis, Va. ATTN: Asst. Commandant, Mili- tary Science and Tactics	69
Commandant, Chemical Corps School, Chemical Corps Train- ing Center, Ft. McClellan, Ala.	70
Commanding General, Research and Engineering Command, Army Chemical Center, Md. ATTN: Special Projects Officer	71
RD Control Officer, Aberdeen Proving Ground, Md. ATTN: Director, Ballistic Research Laboratories	72- 73
Commanding General, The Engineer Center, Ft. Belvoir, Va. ATTN: Asst. Commandant, The Engineer School	74- 76

~~SECRET~~

~~SECRET~~

~~SECRET~~

DISTRIBUTION (Continued)

Copy No.

- Chief of Research and Development, D/A, Washington 25, D. C. 77
- Commanding Officer, Engineer Research and Development Laboratory, Ft. Belvoir, Va. ATTN: Chief, Technical Intelligence Branch 78
- Commanding Officer, Picatinny Arsenal. Dover, N. J. ATTN: ORDBB-TK 79
- Commanding Officer, Frankford Arsenal, Philadelphia, Pa. ATTN: RD Control Officer 80
- Commanding Officer, Army Medical Research Laboratory, Ft. Knox, Ky. 81
- Commanding Officer, Chemical Corps Chemical and Radiological Laboratory, Army Chemical Center, Md. ATTN: Technical Library 82- 83
- Commanding Officer, Transportation R&D Station, Ft. Eustis, Va. 84
- Commanding Officer, Psychological Warfare Center, Ft. Bragg, N. C. 85
- Asst. Chief, Military Plans Division, Rm 516, Bldg 7, Army Map Service, 6500 Brooks Lane, Washington 25, D. C. ATTN: Operations Plans Branch 86
- Director, Technical Documents Center, Evans Signal Lab., Belmar, N. J. 87
- Director, Waterways Experiment Station, PO Box 631, Vicksburg, Miss. ATTN: Library 88
- Director, Operations Research Office, Johns Hopkins University, 6410 Connecticut Ave., Chevy Chase, Md. ATTN: Library 89

NAVY ACTIVITIES

- Chief of Naval Operations, D/N, Washington 25, D. C. ATTN: OP-36 90- 91
- Chief of Naval Operations, D/N, Washington 25, D. C. ATTN: OP-51 92
- Chief of Naval Operations, D/N, Washington 25, D. C. ATTN: OP-53 93
- Chief of Naval Operations, D/N, Washington 25, D. C. ATTN: OP-374 (OEG) 94
- Chief, Bureau of Medicine and Surgery, D/N, Washington 25, D. C. ATTN: Special Weapons Defense Division 95- 96
- Chief, Bureau of Ordnance, D/N, Washington 25, D. C. 97
- Chief, Bureau of Ships, D/N, Washington 25, D. C. ATTN: Code 348 98- 99
- Chief, Bureau of Supplies and Accounts, D/N, Washington 25, D. C. 100

~~SECRET~~

~~TOP SECRET~~

~~SECRET~~
DISTRIBUTION (Continued)

Copy No.

Chief, Bureau of Personnel, D/N, Washington 25, D. C. ATTN: Pers C	101
Chief, Bureau of Yards and Docks, D/N, Washington 25, D. C. ATTN: P-312	102
Chief, Bureau of Aeronautics, D/N, Washington 25, D. C.	103-104
Office of Naval Research, Code 219, Rm 1807, Bldg. T-3, Washington 25, D. C. ATTN: RD Control Officer	105
Commander-in-Chief, U. S. Atlantic Fleet, Fleet Post Office, New York, N. Y.	106-107
Commander-in-Chief, U. S. Pacific Fleet, Fleet Post Office, San Francisco, Calif.	108-109
Commandant, U. S. Marine Corps, Headquarters, USMC, Washington 25, D. C. ATTN: (Code AO3H)	110-113
President, U. S. Naval War College, Newport, Rhode Island	114
Superintendent, USN Postgraduate School, Monterey, Calif.	115-116
Commanding Officer, USN Schools Command, Naval Station, Treasure Island, San Francisco, Calif.	117-118
Director, USMC Development Center, USMC Schools, Quantico, Va. ATTN: MC Tactics Board	119
Director, USMC Development Center, USMC Schools, Quantico, Va. ATTN: MC Equipment Board	120
Commanding Officer, Fleet Training Center, Naval Base, Norfolk 11, Va. ATTN: Special Weapons School	121-122
Commanding Officer, Fleet Training Center (SFPW School), Naval Station, San Diego 36, Calif.	123-124
Commanding Officer, Air Development Squadron 5, USN Air Station, Moffett Field, Calif.	125
Commander, Operational Development Force, U. S. Fleet, Naval Base, Norfolk 11, Va. ATTN: Tact Dev Gp	126
Commander, Operational Development Force, U. S. Fleet, Naval Base, Norfolk 11, Va. ATTN: Air Dept.	127
Commander, Air Force, U. S. Pacific Fleet, Naval Air Station, San Diego, Calif.	128
Commander, Training Command, U. S. Pacific Fleet, c/o Fleet Sonar School, San Diego 47, Calif.	129
Commanding Officer, Naval Damage Control Training Center, U. S. Naval Base, Philadelphia 12, Pa. ATTN: ABC Defense Course	130
Commanding Officer, Naval Unit, Chemical Corps School, Ft. McClellan, Ala.	131
Joint Landing Force Board, Marine Barracks, Camp Lejeune, N. C.	132
Commander, USN Ordnance Laboratory, Silver Spring 19, Md. ATTN: EE	133
Commander, USN Ordnance Laboratory, Silver Spring 19, Md. ATTN: Alias	134

~~SECRET~~
~~CONFIDENTIAL~~

DISTRIBUTION (Continued)

Copy No.

Commander, USN Ordnance Laboratory, Silver Spring 19, Md. ATTN: Aliex	135
Commander, USN Ordnance Test Station, Inyokern, China Lake, Calif.	136
Officer-in-Charge, USN Civil Engineering Research & Evalua- tion Laboratory, Construction Battalion Center, Port Hueneme, Calif. ATTN: Code 753	137-138
Commanding Officer, USN Medical Research Institute, National Medical Center, Bethesda 14, Md.	139
Director, USN Research Laboratory, Washington 25, D. C.	140
Director, The Materiel Laboratory, N. Y. Naval Shipyard, New York, N. Y.	141
Commanding Officer and Director, USN Electronics Laboratory, San Diego 52, Calif. ATTN: Code 210	142
Commanding Officer, USN Radiological Defense Laboratory, San Francisco, Calif. ATTN: Technical Information Division	143-146
Commanding Officer and Director, David W. Taylor Model Basin, Washington 7, D. C. ATTN: Library	147
Commander, Naval Air Development Center, Johnsville, Pa.	148
Commanding Officer, Office of Naval Research Branch Office, 1000 Geary St., San Francisco, Calif.	149-150
Clothing Supply Office, USN Supply Activities, New York, 3d Ave. & 29th St., Brooklyn 32, N. Y. ATTN: R&D Div.	151

AIR FORCE ACTIVITIES

Surplus in TISOR	152
Asst. for Atomic Energy, Headquarters, USAF, Washington 25, D. C. ATTN: DCS/O	153
Asst. for Development Planning, Headquarters, USAF, Wash- ington 25, D. C.	154-155
Director of Operations, Headquarters, USAF, Washington 25, D. C.	156-157
Director of Plans, Headquarters, USAF, Washington 25, D. C. ATTN: War Plans Division	158
Directorate of Requirements, Headquarters, USAF, Wash- ington 25, D. C. ATTN: AFDRQ-SA/M	159
Directorate of Research and Development, Armament Division, DCS/D, Headquarters, USAF, Washington 25, D. C.	160
Directorate of Intelligence, Headquarters, USAF, Washington 25, D. C.	161-162
The Surgeon General, Headquarters, USAF, Washington 25, D. C.	163-164

~~SECRET~~

DISTRIBUTION (Continued)

Copy No.

Commanding General, U. S. Air Forces in Europe, APO 633, c/o PM, New York, N. Y.	165
Commanding General, Far East Air Forces, APO 925, c/o PM, San Francisco, Calif.	166
Commanding General, Alaskan Air Command, APO 942, c/o PM, Seattle, Wash. ATTN: ALOTH	167-168
Commanding General, Northeast Air Command, APO 862, c/o PM, New York, N. Y.	169
Commanding General, Strategic Air Command, Offutt AFB, Omaha, Neb. ATTN: Chief, Operations Analysis	170
Commanding General, Tactical Air Command, Langley AFB. Va. ATTN: Document Security Branch	171-173
Commanding General, Air Defense Command, Ent AFB, Colo.	174-175
Commanding General, Air Materiel Command, Wright-Patterson AFB, Dayton, Ohio	176-178
Commanding General, Air Training Command, Scott AFB, Belleville, Ill.	179-180
Commanding General, Air Research and Development Command, PO Box 1395, Baltimore 3, Md. ATTN: RDDN	181-183
Commanding General, Air Proving Ground, Eglin AFB, Fla. ATTN: AG/TRB	184
Commanding General, Air University, Maxwell AFB, Ala.	185-189
Commandant, Air Command and Staff School, Maxwell AFB, Ala.	190-191
Commandant, Air Force School of Aviation Medicine, Randolph AFB, Tex.	192-193
Commanding General, Wright Air Development Center, Wright- Patterson AFB, Dayton, Ohio. ATTN: WCOESP	194-199
Commanding General, AF Cambridge Research Center, 230 Albany St., Cambridge 39, Mass. ATTN: Atomic Warfare Directorate	200
Commanding General, AF Cambridge Research Center, 230 Albany St., Cambridge 39, Mass. ATTN: CRTSL	201
Commanding General, AF Special Weapons Center, Kirtland AFB, N. Mex. ATTN: Chief, Technical Library Branch	202-204
Commandant, USAF Institute of Technology, Wright-Patterson AFB, Dayton, Ohio. ATTN: Resident College	205
Commanding General, Lowry AFB, Denver, Colo. ATTN: Dept. of Armament Training	206-207
Commanding General, 1009th Special Weapons Sq., Tempo "T", 14th & Constitution Sts., NW, Washington 25 D. C.	208-210
The RAND Corporation, 1700 Main St., Santa Monica, Calif. ATTN: Nuclear Energy Division	211-212

OTHER DEFENSE DEPT. ACTIVITIES

Executive Secretary, JCS, Washington 25, D. C.

213

DISTRIBUTION (Continued)

Copy No.

Director, Weapons Systems Evaluation Group, OSD, Rm 2E1006, Pentagon, Washington 25, D. C.	214
Asst. for Civil Defense, OSD, Washington 25, D. C.	215
Chairman, Armed Services Explosives Safety Board, D/D, Rm 2403, Barton Hall, Washington 25, D. C.	216
Chairman, Research and Development Board, D/D, Washington 25, D. C. ATTN: Technical Library	217
Executive Secretary, Committee on Atomic Energy, Research and Development Board, Rm 3E1075, Pentagon, Washington 25, D. C.	218-219
Executive Secretary, Military Liaison Committee, PO Box 1814, Washington 25, D. C.	220
Commandant, Armed Forces Staff College, Norfolk 11, Va. ATTN: Secretary	221
Commanding General, Field Command, AFSWP, PO Box 5100, Albuquerque. N. Mex.	222-227
Chief, AFSWP, PO Box 2610, Washington 13, D. C.	228-236

ATOMIC ENERGY COMMISSION ACTIVITIES

University of California Radiation Laboratory, PO Box 808, Livermore, Calif. ATTN: Margaret Folden	237
U. S. Atomic Energy Commission, Classified Document Room, 1901 Constitution Ave., Washington 25, D. C. ATTN: Mrs. J. M. O'Leary (for DMA)	238-240
Los Alamos Scientific Laboratory, Report Library, PO Box 1663, Los Alamos, N. Mex. ATTN: Helen Redman	241-243
Sandia Corporation, Classified Document Division, Sandia Base, Albuquerque, N. Mex. ATTN: Wynne K. Cox	244-263
Weapon Test Reports Group, TIS	264
Surplus in TISOR for AFSWP	265-289

ADDITIONAL DISTRIBUTION

Director of Special Weapons Developments, OCAFF, Fort Bliss, Texas. ATTN: Major Hale Mason, Jr.	290
--	-----

