

AD-A956 078



1

AFSCM 375-5

AIR FORCE SYSTEMS COMMAND

DTIC

ELECTE

JAN 29 1992

S

D

SYSTEMS MANAGEMENT

SYSTEMS ENGINEERING

MANAGEMENT PROCEDURES

This document has been approved for public release and sale; its distribution is unlimited.

92 1 28 092

92-02311



FOREWORD

The 375 series of Air Force Systems Command manuals constitutes a procedural baseline for management of programs involving relatively complex hardware, software, and management interfaces. These manuals have been developed from critical analyses of AFSC management experience with major system programs. They represent a standardized, integrated body of proven techniques which, although designed to implement Air Force 375-series regulations governing acquisition of Air Force systems, are applicable as well, to many nonsystem programs with management requirements similar to those of major system programs. Consequently, HQ AFSC will direct the application of these manuals to all programs which Headquarters USAF places under AFR 375 management and, as appropriate, to other AFSC efforts.

The 375 series of AFSC manuals was designed to cover foreseen management needs of systems programs. Consequently, no program will find all provisions of all manuals necessary to its particular needs. These manuals are to be employed selectively only to the extent that they serve the needs of individual programs. It is the responsibility of each program director to determine when departures are warranted and request necessary waivers under the provisions of AFSCR 375-2.

AFSCM 375-5 serves two purposes. First, it defines a common system analysis process that leads to system definition in terms of performance requirements on a total system basis. Secondly it provides a detailed "road map" of engineering actions during a system's life cycle in their relative order of occurrence. It is interrelated with AFSCM 375-1, "Configuration Management During Definition and Acquisition Phases," in that the product of the analysis defined by it is required to prepare Part I of the specifications which form the design requirements baseline. It supplements both AFSCM's 375-3 and 375-4 by expanding on the engineering actions accomplished during the typical system life cycle.

With the increasing complexity of military systems, AFSCM 375-5 represents a forward step to improved management techniques. Any comments or questions regarding this or any of the 375-series documents should be referred to AFSC (SCSV) for resolution.

B. A. Schriever

B. A. SCHRIEVER
 General, USAF
 Commander



UNANNOUNCED

Accession No.	
NTIS	CR641
DTIC	FA3
Unannounced	
Justification	
By	
Dist to	
Date	
Dist	
A-1	734

DISCLAIMER NOTICE

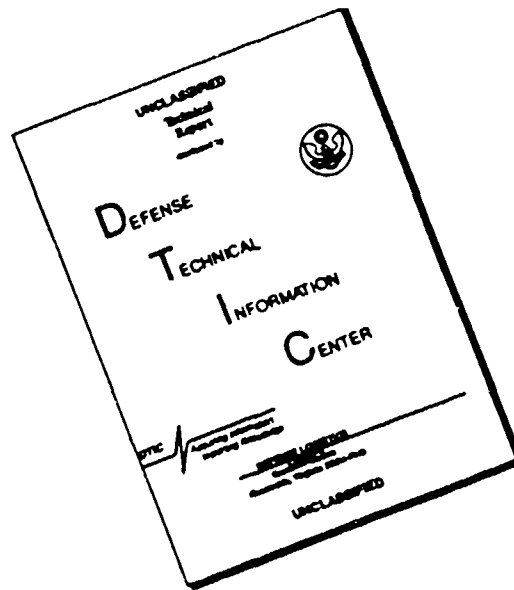

THIS DOCUMENT IS BEST QUALITY AVAILABLE. THE COPY FURNISHED TO DTIC CONTAINED A SIGNIFICANT NUMBER OF PAGES WHICH DO NOT REPRODUCE LEGIBLY.

Systems Management

SYSTEM ENGINEERING MANAGEMENT PROCEDURES

THIS MANUAL ESTABLISHES THE REQUIREMENTS, POLICIES, AND PROCEDURES FOR SPO MANAGEMENT OF THE SYSTEM ENGINEERING EFFORT. IT IS THE SYSTEM ENGINEERING MANAGEMENT STANDARD FOR ALL FUTURE AFSC SYSTEM ACQUISITION PROGRAMS AND PROJECTS.

CONTENTS

	<i>Paragraph</i>	<i>Page</i>
CHAPTER 1—Introduction		
General	1	1
Uniform Design Process	2	1
Management Tool	3	2
Abbreviations and Terms Used in This Manual	4	2
CHAPTER 2—Objectives		
Fundamental Objectives	5	7
Specific Objectives	6	8
CHAPTER 3—Scope		
Applicability	7	9
Manual Organization	8	9
CHAPTER 4—Policy		
Basic Policy	9	11
SPO Project Office Responsibilities	10	11
Review Requirements	11	12
Reviews to be Accomplished	12	13
Documentation Requirements	13	15
Air Force Management Control of System Engineering	14	15
Contractor Management Control of System Engineering	15	16
System Engineering Control Summary	16	16
CHAPTER 5—Concept		
Fundamental Concepts	17	19
CHAPTER 6—Summary of System Engineering Management Process		
Fundamental Cycle of the System Engineering Management Process	18	23
Iteration of the Process	19	24
Documentation	20	25
OPR: SCSV		
DISTRIBUTION: F		
X: (See page vi)		
EXHIBIT 1—Procedures for System Engineering Management		
Introduction	1.0	27
Conceptual Phase Requirements	2.0	28
Definition Phase Requirements	3.0	33
Acquisition Phase Requirements	4.0	59
Operational Phase Requirements	5.0	74

EXHIBIT 2—Implementation Requirements

	<i>Paragraph</i>	<i>Page</i>
Purpose and Scope.....	1.0	75
General.....	2.0	75
GSE TDC or SEG R&T Responsibilities.....	3.0	75
AFPRO Responsibilities.....	4.0	77
Participating Contractor Responsibilities.....	5.0	78
Integrating Assembly on Prime Contractor Responsibilities.....	6.0	79
Integration of Requirement Documentation.....	7.0	80
System Engineering Implementation Plan.....	8.0	80
Summary of System Engineering Documentation and Application Criteria.....	9.0	80
System Engineering Documentation Uses.....	10.0	82
Special Applications of AFSCM 375-5.....	11.0	84
System Engineering Documentation Formal Submittal.....	12.0	84
System Engineering Documentation Changes.....	13.0	85
ATTACHMENT 1—Detail Procedures for Completing System Engineering Documentation		
Preparation of Functional Flow Block Diagrams.....	1.0	87
Requirements Allocation Sheet.....	2.0	90
Trade Study Reports.....	3.0	94
Schematic Block Diagrams.....	4.0	95
Time Line Sheet.....	5.0	96
Design Sheet.....	6.0	97
Facility Interface Sheets.....	7.0	111
End Item Maintenance Sheet.....	8.0	115
Maintenance Loading Analysis.....	9.0	119
Calibration Requirements Summary.....	10.0	123
ATTACHMENT 2—Examples of System Engineering Documentation		
Fundamental Cycle of System Engineering Management Process.....	1.0	127
Top Level Functional Flow Block Diagrams for a Space System and a Missile System.....	2.0	149
Electronic System Functional Flow Block Diagrams.....	3.0	152
Aeronautical System Functional Flow Block Diagrams.....	4.0	156
Facility Functional Flow Block Diagrams.....	5.0	156
Requirements Allocation Sheet.....	6.0	161
Trade Study Report.....	7.0	166
Schematic Block Diagrams.....	8.0	173
Time Line Sheet.....	9.0	187
Design Sheet.....	10.0	139
Facility Interface Sheet.....	11.0	203
End Item Maintenance Sheet.....	12.0	205
Maintenance Loading Analysis.....	13.0	208
Calibration Requirements Summary.....	14.0	212
MGE Provisioning Figure A.....	15.0	215
Facility Perspective and Facility Schematic Diagrams.....	16.0	217
Electronics System Schematic Block Diagrams.....	17.0	226

ILLUSTRATIONS

<i>Figure</i>		<i>Location</i>	<i>Page</i>
1	System Program Office Organization.....	Chap 2	7
2	System Engineering Control Summary.....	Chap 4	17
3	Evolution of Basic System Elements.....	Chap 5	21

Figure		Location	Page
4	Fundamental Cycle of System Engineering Management Process.....	Chap 6	23
5	System Engineering Management Process.....	Atch 2	229
6	Summary of System Engineering Documentation and Application Criteria.....	Exh 2	81
7	System Engineering Documentation Submittal and Approval/Comments Flow.....	Exh 2	85
8	Format for Functional Flow Block Diagrams.....	Atch 1	89
9	Requirements Allocation Sheet.....	Atch 1	94
10	Basic Technique for Developing Schematic Block Diagrams.....	Atch 1	96
11	Time Line Sheet.....	Atch 1	97
12	Design Sheet.....	Atch 1	110
13	Facility Interface Sheet.....	Atch 1	114
14	End Item Maintenance Sheet (Manual).....	Atch 1	119
15	Maintenance Loading Sheet (Example).....	Atch 1	121
16	MGE Utilization Sheet (Example).....	Atch 1	122
17	Personnel Utilization Sheet (Example).....	Atch 1	122
18	Calibration Requirements Summary.....	Atch 1	125
19	First Level Functional Diagram Preceding Example of Step 1.....	Atch 2	128
20	Second Level Functional Diagram Preceding Example of Step 1.....	Atch 2	129
21	Step 1 of System Engineering Management Process.....	Atch 2	130
22	Trade Study Matrix in Support of Step 2.....	Atch 2	131
23	Step 2 of System Engineering Management Process (4 pages).....	Atch 2	132
24	Step 3 of System Engineering Management Process.....	Atch 2	136
25	Schematic Diagram in Support of Step 3.....	Atch 2	137
26	Step 4 of System Engineering Management Process (11 pages).....	Atch 2	138
27	Top Level Functional Diagram for a TMXX Missile System.....	Atch 2	150
28	Top and First Level Functional Diagram for a 6XX Orbiting Space System.....	Atch 2	151
29	Top Level Functional Level Diagrams for a 4XXL Electronic System.....	Atch 2	153, 154
30	First Level Functional Diagram for a 4XXL Electronic System.....	Atch 2	154
31	Second-Level Functional Diagram for a 4XXL Electronic System.....	Atch 2	155
32	Top Level Functional Diagram for a F2XX Aeronautical System.....	Atch 2	157
33	First Level Functional Diagram for a F2XX Aeronautical System.....	Atch 2	158
34	Second-Level Functional Diagram for Facilities to Support the SM-XX System.....	Atch 2	159
35	Third-Level Functional Diagram for Facilities to Support the SM-XX System.....	Atch 2	160
36	RAS for the Function "Integrate and Service SLS" (2 pages).....	Atch 2	162
37	Functional Diagram of "Integrate and Service SLS".....	Atch 2	164
38	RAS for the Function "Integrate Solid Rocket Motor with Core and Pay- load".....	Atch 2	165
39	Trade Study—Comparison of Methods for Measuring Quantities of Loaded Propellant (8 pages).....	Atch 2	167
40	Schematic Diagram of Communications Subsystem.....	Atch 2	176
41	Schematic Diagram (First Level) of Standardized Launch Control System 9XX.....	Atch 2	177
42	Schematic Diagram (Second Level) of Vehicle Checkout Group.....	Atch 2	179
43	Schematic Diagram (Third Level) of Launch Command Function.....	Atch 2	181
44	Schematic Diagram of Propellant Transfer and Pressurization Control.....	Atch 2	183
45	Schematic Diagram of Propellant Transfer and Pressurization Subsystem.....	Atch 2	185
46	Time Line of Launch Countdown.....	Atch 2	188
47	Design Sheet for Communications Control Panel (13 pages).....	Atch 2	190

<i>Figure</i>	<i>Location</i>	<i>Page</i>
48	Facility Interface Sheet for an Electro-Theodolite Set	Atch 2 204
49	End Item Maintenance Sheet for a Telephone Repeater	Atch 2 206
50	RAS for Maintenance Function "Test Telephone Repeater"	Atch 2 207
51	Maintenance Loading	Atch 2 209
52	MGE Utilization	Atch 2 210
53	Personnel Utilization	Atch 2 211
54	Excerpts from CRS for Propulsion Subsystem and a Guidance Subsystem	Atch 2 213
55	Excerpts from CRS for a Rocket Engine and a Launch Console	Atch 2 214
56	Modified MGE Provisioning Figure A	Atch 2 216
57	Facility Perspective for a Maintenance Facility	Atch 2 218
58	Facility Site Plan for a Maintenance Facility	Atch 2 219
59	Maintenance Facility Floor Plan	Atch 2 221
60	Schematic Diagram for SMAB Environmental Control	Atch 2 223
61	Schematic Diagram for Facilities Water Distribution	Atch 2 225
62	Schematic Diagram (Second Level) of Warning and Surveillance Personnel for 4XXL System	Atch 2 227
DISTRIBUTION X (Continued):		
	Letterkenny Army Depot (SSMLE-ATD), Chambersburg, Pa. 17201	125
	Defense Supply Agency (DSAH-XM), Bldg. 6, Door 5, Cameron Station, Alexandria, Va. 22314	400
	Bureau of Naval Weapons (Code PQC-2), Room 3627 Munitions Bldg., Washington, D.C. 20360	70

FOR THE COMMANDER



JOHN F. RASH
Colonel, USAF
Director of Administrative Services

Chapter I

INTRODUCTION

1. GENERAL. In recent years increasingly complex military systems have been designed and developed. During this time, there has been an emerging awareness of the need for and the importance of **TOTAL SYSTEM DESIGN**. Groups of specialists emphasizing reliability, maintainability, survivability/vulnerability, facilities, transportation, safety, human performance, and system testing have forced a recognition that a system does not consist of equipment alone.

a. A "system" as defined in AFR 375-1 is "a composite of equipment, skills, and techniques capable of performing and/or supporting an operational role." Through practice the elements of a system have come to include the organizational equipment required to perform the operational mission, equipment for checkout, maintenance, and training; facilities required to operate and maintain the system; personnel trained and possessing the proper skills to operate and maintain the system; and the computer programs and procedures necessary to operate and maintain the system. In addition, the term "system" encompasses all the ancillary equipment required such as instrumentation, depot tooling and test equipment, installation and checkout equipment, etc.

b. All parts of a system must work together and have a common unified purpose: namely, to contribute to the production of a single set of highest outputs based on given inputs. This absolute necessity for coherence requires an organization of creative technology which can lead to the successful design of a complex military system. This organized creative technology is called "system engineering." Within this manual, system engineering encompasses terms such as system approach, system analysis, system integration, functional analysis, system requirements analysis, reliability analysis, maintenance and maintainability task analysis, and similar functions.

c. System engineering is fundamentally concerned with deriving a coherent total system design to achieve stated requirements. It is vital that those responsible for the management of system engineering recognize the predominant and highly complementary role played by engineering specialists in satisfying total system design requirements. The interplay between the system engineers and the engineering specialists requires the closest coordination and is a major management problem which must be faced and solved.

2. UNIFORM DESIGN PROCESS. No two systems are ever alike in their developmental requirements. However, there is a uniform and identifiable process for logically arriving at system decisions regardless of system purpose, size, or complexity. This manual describes and specifies such a process: i.e., a system engineering management process. The system engineering process described herein is used to logically consider and evaluate each of the innumerable military, technical, and economic variables involved in total system design. Selecting the method of system operation and the system elements is a highly involved process since a change in one system variable will usually affect many other system variables, and rarely in a linear fashion. The generation of a balanced system design requires that each major design decision be based upon the proper consideration of system variables, such as facilities, equipment, computer programs, personnel, procedural data, training, testing, logistics, and intrasystem and intersystem interfaces. All considerations must be made within the effectiveness parameters of time, cost, and performance as defined or developed for the system. This logical consideration, evaluation, and selection of a balanced system design necessitates the closest coordination of selected skilled personnel who are to work as a homogeneous system engineering design team. The system

engineering team is responsible for translating operational or advanced developmental requirements into an operable and economical system. This responsibility will not be satisfied until system documentation is complete: early tests have proven the adequacy of Detail Specifications for design/development and production; and final system tests and early operational use have proved that the equipment, facilities, trained personnel, and procedural data will satisfy the required military mission.

3. MANAGEMENT TOOL:

a. This manual is intended to serve as a management tool and is addressed to the definition of system engineering management procedures required to integrate the scientific engineering skills involved in designing military systems. It does not discuss the application of basic scientific tools of system engineering, such as economics, chemistry, mechanics, electronics, mathematics, or psychotechnics.

b. Succeeding chapters describe the significant aspects of the overall system engineering management process and summarize its objectives and AFSC policies and procedures governing execution of the function. Step-by-step procedural guidance is contained in the exhibits to the manual. Both the succeeding chapters and the exhibits are keyed to reference material and examples of system engineering documentation contained in the attachments.

c. It should be clearly understood from the outset that application of the requirements of this manual will, more often than not, necessitate interpretation for a specific program which then must be included in sufficient detail in the work statement of the applicable contractual instruments to be enforceable. Effective implementation of this manual is dependent upon the vision, degree of understanding, and interest and acceptance by the persons to whom its application is entrusted.

4. ABBREVIATIONS AND TERMS USED IN THIS MANUAL. For explanation of terms not included below, see the following:

- AFR 375-1—Management of System Programs
- AFR 375-2—System Program Office
- AFR 375-3—System Program Director

AFR 375-4—System Program Documentation

AFM 11-1—Air Force Glossary of Standardized Terms and Definitions

AFSCM 375-1—Configuration Management During the Definition and Acquisition Phases

AFSCM 375-2—System Program Office Manual

AFSCM 375-4—System Program Management Manual

(A)—Alphabetic designator.

AAE—Aerospace ancillary equipment—Equipment other than organizational (AVE, OGE, or MGE) required to install, assemble, check-out, test, repair, or train personnel to operate, control, or maintain the system. In cases where multiple utilization is made of organizational equipment (e.g., where organizational MGE test equipment is used in the assembly process in the factory), the organizational categorization (MGE) will apply. Examples of AAE include flight test equipment (instrumentation equipment); depot tooling and depot test equipment (inertial measurement unit calibration test equipment); installation and checkout (I&C) equipment (initial balancing and adjustment equipment for environmental controls); safety-destruct; classes I, II, and III training equipment (crew trainer, mission simulator, actual system equipment as parts or components thereof); and mobile training units.

A&E—Architectural and engineering.

Activation Functions—System production, training, and I&C actions that are necessary to initially procure, fabricate, train, assemble, handle, store, and prepare for shipment the system or system elements at the point of acquisition, and to transport, receive, install, checkout, and, as required, store the system or systems elements at the use location. Such actions are normally nonrepetitive actions during the development program in preparation for system, subsystem, or end-item testing.

ADO—Advanced development objective.

ADPE—Automated data-processing equipment.

AFCMD—Air Force Contract Management Division.

10 March 1966

AFSCM 375-5

AFSC—Air Force specialty code.

AFTO—Air Force technical order.

AMA—Air materiel area.

(A/N)—Alpha/numeric designator.

AVE—Aerospace vehicle equipment.—Equipment which is, of itself, or is part of the manned or unmanned vehicle which operates in the aerospace environment. Examples of aerospace vehicle equipment include bomb-NAV computer, airplane, booster, orbiting space station, engines, reentry vehicle, command module, and guidance package.

CCB—Configuration control board.

CCN—Contract change notice.

CDR—Critical design review.

CEI—Contract end item.

CEIN—Contract end-item number.

Computer Program—The totality of computer programs used to apply the capability of computers to perform specific mission or tasks. The programs can be grouped into three categories: operational, utility, and support. The operational computer program is the link between the computer equipment and the military operators. It is the computer program which provides automated information-processing support to the using command in performing its operational mission. The utility computer programs are programming "tools" such as compilers, assemblers, etc., necessary in the production, development, modification, and use of the operational programs. The support computer programs are those which are used for a variety of monitoring functions but which are not required for system operations.

Critical RPIE Subsystem—A functional subsystem of RPIE, designated as critical early in the definition phase for purposes of analysis of special design treatment. Criteria for designation as critical shall be based on the functional relationship to direct mission operations or support, technical complexity, or safety of personnel or equipment. Critical RPIE subsystems will normally be designated only in conjunction with TSRP.

CRS—Calibration requirements summary.

DRN—Documentation revision notice.

ECP—Engineering change proposal.

Effectiveness Factors—Availability, dependability, and capability and the attendant subdivisions or subroutines including reliability, maintainability, safety, survivability, and vulnerability.

EPOE—End piece of equipment.

ERRC—Expendability - recoverability - reparability cost code.

FACI—First article configuration inspection.

Facilities—Buildings, structures, or other real-property improvements as separately identified on the real-property records, including items of real-property installed equipment attached to or installed in real property. Facilities and RPIE are further broken down into the following categories: (1) technical support real property (TSRP), (2) critical RPIE subsystem; (3) nontechnical support real property (NSRP); (4) industrial facilities.

FCEI—Facility contract end item.

Frequency Allocation—The allocation of frequency spectrum to accommodate new or proposed electromagnetic radiating equipment. For U.S. military systems, the U.S. Joint Frequency Panel, Military Communications Electronics Board (JFP MCEB), approves the development and proposed operation of electromagnetic radiating equipment. Their deliberations are based on joint U.S. military frequency planning and consideration of international and national agreements.

FSE—Facility system engineering.—The system engineering effort related to the total development of the complete technical support facility element of a system, including its earliest definition, site planning, criteria development, design, and logistics and personnel subsystem support. This function coordinates the traditional A&E activities and requirements of the MCP with the system engineering process on a continuing basis from early system concepts to turnover of a complete operational system. The facility system engineer (FSE) is the contractor, AFSC division civil engineering activ-

ity, or combinations thereof that perform the FSE function.

Function—A discrete action required to achieve a given objective, to be accomplished by hardware, computer program, personnel, facilities, procedural data, or a combination thereof. It is an operation the system must perform in order to fulfill its intended mission.

G&C—Guidance and control.

GFE—Government-furnished equipment.

GFP—Government-furnished property.

Gross Function—An operations, maintenance, test, or activation function, or combination thereof, that represents the first possible functional breakdown of a system. Examples of such functions for a missile system could be "flight mission," "launch missile," "missile pre-launch checkout," "organizational maintenance," "produce system," "test system," etc.

GSE/TDC—General system engineering/technical direction contractor, including normal industrial companies providing such services.

IAC—Integrating and assembly (including checkout).

I&C—Installation and checkout.

IM—Item manager.

Indenture—A method of showing relationships to indicate dependence and an order of dependence. Indentures may be shown by actual indentation, numerically or alphabetically. Indenturing breaks down an item into assemblies, subassemblies, components, and parts. The term also applies to the successive breakdown of items such as functional diagrams and schematic diagrams. In this manual, alphabetical indenture is specified (reference Specification MIL-M-8910).

Industrial Facilities—Test, plant, and production facilities, including industrial construction, plant modification or expansion, special tooling, and equipment, acquired with the authorization and funding for Air Force R&D, which are required by a system contractor for research, development, production, and operation of a system element.

IPB—Illustrated Parts Breakdown.

Intersystem/Intrasystem Interfaces—A common boundary between two or more systems/equipments. An example of intersystem interface is a command and control system, interfacing with a strategic weapon system. An example of an intrasystem interface is the autopilot (a system element) interfacing with the pneumatic components of the directional control equipment of the aerospace vehicle.

LP/BP—Local purchase or base procurement.

Maintenance Functions—Actions on a system or system element that are necessary in order to return a failed system element to readiness (corrective maintenance functions) or to insure continuing normal system readiness (preventive maintenance functions). Corrective maintenance functions would include functions such as malfunction detection, isolation, repair replacement, post-repair checkout, and repaired post transport and storage for any system element at any point in the system cycle.

MCN—Master control number.

MCP—Military construction program.

MDS—Mission, design, series.

MGE—Maintenance ground equipment.

MIP—Materiel improvement project.

MTBF—Mean time between failures.

MTBM—Mean time between (preventive or corrective) maintenance actions.

(N)—Numeric designator.

NHA—Next higher assembly.

NSRP—Nontechnical support real property. Fixed capital facility assets of the Air Force, acquired within the authorization and fundings of the MCP which are not system-peculiar or system-oriented and provide conventional nontechnical support to a system; i.e., not critical to the system. Examples include administration buildings, cafeterias, and conventional maintenance shops and warehouses.

OCL—Operational control level.

OGF—Operating ground equipment.

Operations Functions—Repetitive using-command/agency actions performed on a system that has been turned over to the using command and that are required to accomplish the given system objectives in a normal uninterrupted sequence. Examples of such functions for a deployed missile system would include receiving alert indications, positioning or transporting the missile, checking out the system, launching, and accomplishing inflight operations, including required tracking and limited data acquisition necessary to accomplish the basic mission.

OSR—Operational support requirement.

PC—Prime contractor.

PCO—Procuring contracting officer.

PDR—Preliminary design review.

PERT/Cost—Program evaluation review technique and cost.

PMEL—Precision measurement equipment laboratory.

PSPP—Proposed system package plan.

PTDP—Preliminary technical development plan.

QOR—Qualified operational requirement.

QQPRI—Qualitative and quantitative personnel requirements information.

RAS—Requirements allocation sheet.

RPIE—Real-property installed equipment.

RFP—Request for proposal.

SCN—Specification change notice.

SEG/R&T—System Engineering Group of the Research and Technology Division.

SEIP—System engineering implementation plan.

SOR—Specific operational requirement.

SOR/OSR/ADO—Specific operational requirement/operational support requirement/advanced development objective.

SPD—System program director.

SPO—System program office.

SRA—Specialized repair activity.

SSM—System support manager.

System Element—A constituent part of a weapon, support, or electronic system, normally one of the following: (1) hardware, (2) computer program, (3) facilities, (4) personnel, and (5) procedural data.

System Segment—A discrete package of system performance requirements, functional interfaces, and contract end items contracted to one contractor or assigned to one Government organization directly responsible to the procurement agency for that part of a system's total performance.

System Engineering Management—The combination of management actions to be accomplished during the life cycle of the system program by the SPO, SEG, R&T, GSE/TDC, contract management activity, and contractors necessary to control and document the engineering effort directed toward meeting total system requirements. These actions include the establishment and maintenance of the technical integrity over all elements of the system including hardware, computer program, procedural data, facilities, and personnel requirements.

TCTO—Time compliance technical order.

TD—Technical direction.

TEPI—Training equipment planning information.

Test Functions—Actions necessary to demonstrate or otherwise verify that the system and/or system elements are capable of performing basic mission requirements. Such functions would include test requirement determination, testing, test support, and test result evaluation during the conceptual, transition, definition, acquisition, and operational phases (reference AFSCM 375-4). This would include definition phase feasibility tests; engineering evaluation tests, reliability tests, production tests, and other category I tests: acceptance test/verifications; I&C tests; category II tests, including technical approval demonstrations to the using command/agency; follow-on developmental tests; and follow-on operational tests.

TSRP—Technical support real property—Fixed capital facility assets of the Air Force, normally acquired within the authorization and funding of the MCP which are system-peculiar or system-oriented and which are required for all technical aspects of the test, development, and direct mission support of a specific system. Examples of TSRP are (1) operations facilities directly associated with and required for the operation or readiness of the system. Their relationship to other system elements is so intimate that definition of requirements, design, and construction must be accomplished in conjunction with other system elements on a total system basis to meet system objectives; i.e., launch facilities, protective silos, command and control facilities, etc.; (2) technical support facilities for direct and essential support of the operational system and requiring close control

and coordination during definition and design to insure proper interface with OGE and AVE subsystems, i.e., assembly and checkout facilities, fuel storage, and processing and handling, special component receiving, handling, and storage, etc.; (3) test facilities required for test and validation of system components or subsystems where critical configuration and interface between the component or subsystem and the facility must be maintained through the system development and production cycles; (4) range support facilities providing unique and critical system functions in support of the operational or test mission; and (5) special training facilities required for training and subject to the same basic requirements and controls as the operational or support facility.

WUC—Work unit code.

Chapter 2

OBJECTIVES

5. FUNDAMENTAL OBJECTIVES:

a. The basic objective of system engineering is to specify the hardware, computer programs, facilities, personnel, training, and procedural data required to meet AF system mission requirements. This manual prescribes the policies and procedures to be followed in managing the system engineering effort. The system engineering management process encompasses the early identification of (1) AF system objectives, (2) the "design to" requirements necessary to meet these objectives, (3) the "build to" requirements which prescribe the ultimate configuration of the system to be delivered to the user, and (4) the requirements for personnel, training, procedural data, and logistic support. System engineering management as prescribed in this manual, will be initiated in the latter part of the conceptual phase and continue through the definition phase, acquisition phase, and early operational phase of the system life

cycle (reference AF 375 series regulations and AFSCM 375-4). The overall relationship of this manual to other system management manuals is illustrated in figure 1.

b. The two fundamental purposes of the system engineering management process are (1) to establish a single analysis, definition, trade-off, and synthesis of requirements and design solutions on a total system basis and (2) to provide a clear and concise reference source for communication of selected system design solutions between the AF organizations, between AF and the contractors, and among contractor organizations. Design trade-offs must be made in terms of time, cost, and performance, with these factors weighted as appropriate for the system being developed. The single reference source will be evolved in consonance with the design process and will be the basis for the identification, control, and accounting of the system by means of configuration management procedures specified in AFSCM 375-1.

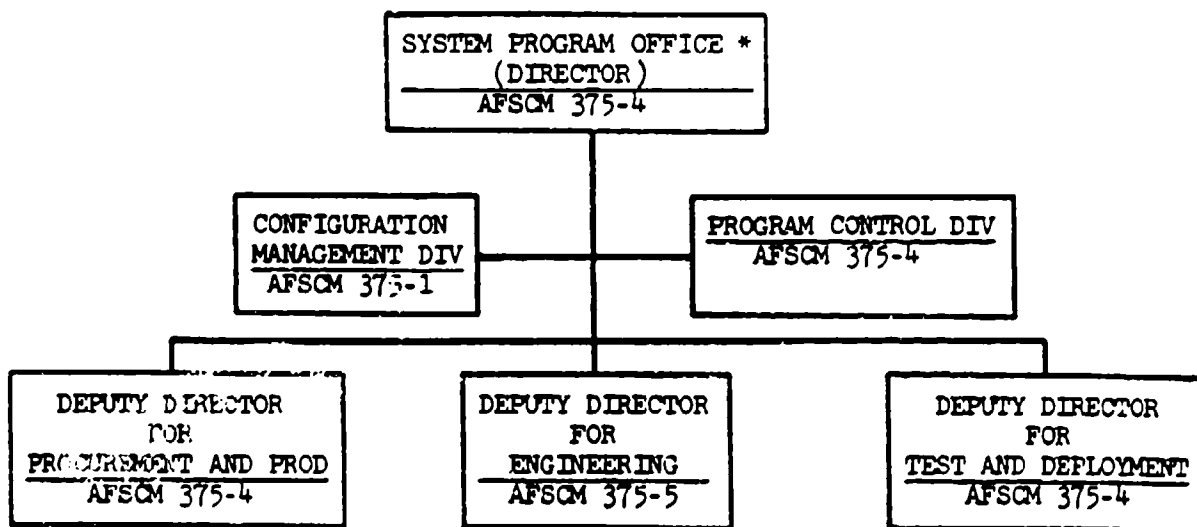

Figure 1. System Program Office Organization (reference AFSCR 23-43).

*For an introduction to the system program office (SPO), reference AFSCM 375-3.

6. SPECIFIC OBJECTIVES. The system engineering management effort will be conducted to satisfy the following specific objectives:

a. Define hardware, computer programs, facilities, personnel, and procedural data that are required to fulfill total system or project objectives.

b. Develop performance, design, and test requirements during early design on the basis of the integration and trade-off of system performance requirements, system elements (equipment, computer programs, facilities, procedural data, and personnel) and system and end-item design constraints (including, for example, reliability, maintainability, survivability, vulnerability, human performance, safety, environment, life support/biomedical, procurability, producibility, interchangeability, and transportability).

c. Interrelate the design effort with the development of requirements for test, production, installation and checkout (I&C), acceptance, quality assurance, maintenance, and personnel at an early point in the development cycle, and maintain this interrelationship throughout the life cycle of the system.

d. Provide early information necessary for reviewing items in the DOD inventory which can meet the requirements of the system under consideration.

e. Define and control the intersystem and intrasystem interfaces at each step throughout the definition and acquisition process.

f. Provide the necessary criteria in the system performance/design requirements general specification and detail specifications for evaluating contractor design development and production effort against specified performance as the basis for incentive-type procurement.

g. Establish procedures for the control and

accomplishment of system design throughout the life cycle of the program.

h. Provide a framework of coherent system requirements to be used as performance, design, and test criteria; serve as source data for development plans, contract work statements, specifications, test plans, design drawings, and other engineering documentation.

i. Establish a single source of standardized system requirement documentation which will provide for clear and concise communication of requirements between the AF and contractors and among contractors. Establish a standardized documentation which will provide a common base for SPO evaluation of contractor proposals.

j. Provide a functional system model for use in generating mathematical models, including simulation techniques, to quantitatively evaluate system effectiveness before, during, and after design, fabrication, and test of a system.

k. Provide the technical basis for configuration management activities, such as definition and justification of program requirements; establishment of the program requirements baseline, design requirements baseline, and product configuration baseline; development of specifications; and justification for engineering change proposals.

l. Eliminate duplication in program requirement documentation.

m. Provide integrated source data for determining training requirements, such as training courses and training equipment.

n. Provide integrated source data for determining logistic requirements, such as provisioning quantities, spare parts, and depot tooling.

o. Provide source data for deriving operating and maintenance procedures, such as technical manuals, technical orders, and utility manuals.

Chapter 3**SCOPE****7. APPLICABILITY**

a. The system engineering procedures specified herein are applicable to any system program or project for which a formal definition phase or acquisition phase is applicable or directed by higher headquarters (reference AFSCM 375-4). However, these procedures can be readily adapted to benefit system programs and projects for which a definition or acquisition phase, in accordance with AFR 375-1, is not directed (reference para. 11.0 exhibit 2).

b. This manual incorporates the requirements of MIL-D-9412D (USAF), "Data for Aerospace Ground Equipment (AGE)."

8. MANUAL ORGANIZATION. This manual establishes and describes a methodology for accomplishing the system engineering management process. It contains two exhibits, in addition to the main body provided in chapters 1 through 6. These exhibits will provide a

basis for contractual requirement on applicable systems or projects as specified below:

a. Exhibit 1, "Procedures for System Engineering Management," presents the requirements to be met by the SPO and contractors in accomplishing system engineering. Exhibit 1 has been designed for contractual application through the use of the procedures outlined in exhibit 2.

b. Exhibit 2, "Implementation Requirements," presents SPO requirements for implementing this manual, an outline for the required system engineering implementation plan (SEIP), and criteria for selecting the system engineering documentation applicable to the specified system or project. Also included are the responsibilities of the Systems Engineering Group of the R&T Division (SEG/R&T), the general system engineering technical direction contractor (GSE/TDC), the integrating assembly contractor (IAC), the prime contractor (PC), and participating contractors.

Chapter 4

POLICY

9. BASIC POLICY. The SPO will conduct system engineering management in accordance with the responsibility, documentation review, and control policies detailed in this chapter. This chapter applies to any part of or exhibits to AFSCM 375-5 which may be individually implemented in a contract and will control in case of conflict.

a. AFSCM 375-5 defines an orderly process for achieving total system design requirements and the documentation of technical information leading to those requirements. It is not intended to direct the contractor on how to manage or organize, nor does it create approval or disapproval rights beyond those called out elsewhere in the contract.

b. Responsibility rests with the system program director (SPD) for effective implementation of system engineering management within the SPO and other interested governmental agencies, participating contractors, and the SEG/R&T or GSE/TDC. Detailed policies and procedures outlining the responsibilities of SEG/R&T and all contractors, including GSE/TDC, for the system engineering processes are specified in exhibit 2.

c. Formal reviews will be scheduled and conducted to provide clear evidence of the progress of the total program and of its technical adequacy in all respects. Such reviews will be comprehensive and will be based on the system engineering process prescribed by this manual. Reviews will include all the technical information relating to the item under study necessary to show its overall adequacy and will incorporate the results of the investigation of the item's technical adequacy with respect to specific disciplines; e.g., maintainability, safety, human performance engineering, electrical design, and mechanical design. No formal reviews will be conducted to assess less than the total design adequacy of an item.

d. Documentation of the system engineering effort will be in accordance with the requirements of this manual. The scope and degree of complexity of the system under consideration may not warrant full implementation of the procedural and documentation requirements specified. The degree to which these requirements are to be applied will be specifically set forth in the PTDP for the definition phase and the PSPP for the acquisition phase (reference para. 8.0 of exhibit 2). Military specifications requiring analytical effort may be applicable to system definition and acquisition. These specifications will be applied only to the extent that they supplement the requirements of this manual. Duplicative effort is to be avoided.

e. Control is to be achieved by directive with Government agencies or by contract with industrial organizations requiring these agencies to comply with the process prescribed by this manual.

f. System engineering management includes the responsibilities of the SPO, the SEG/R&T, and all contractors (including the GSE/TDC) engaged in the engineering effort required to meet system requirements. The above definition includes, as appropriate to the program contract and management structure, the function of facility system engineering (FSE) either as an independent FSE contractor team effort or as an AFSC division civil engineering activity effort supporting the SPO and employing an A&E contractor to accomplish FSE.

10. SPO/PROJECT OFFICE RESPONSIBILITIES. The SPO or project office will provide overall management of the system engineering process defined herein. Hereafter, "SPO" refers to system program office or project office, whichever is applicable. Management includes exercising authority over the development of the system engineering documentation, related con-

controls, and reviews as prescribed by this manual. The SPD has the final approval authority over any controls, reviews, and documentation prescribed by this manual. Specific attention will be given to insuring (1) accomplishment of the SPO actions described in exhibit 1, and (2) the utilization of the system engineering process in determining the impact of program changes on total system requirements. The overall responsibility for insuring participating agency compliance with the system engineering process will be assigned to the SPD. The SPO deputy director of engineering will be assigned the responsibility for technical and administrative management of the detailed system engineering effort required by this manual. In addition to technical task, the deputy director of engineering personnel responsible for system engineering will (1) provide overall guidance to SEG/R&T or GSE/TDC and the contractors on the procedures of this manual; (2) administer and coordinate appropriate schedules; (3) serve as technical adviser to all SPO and SPO-related organizations on the procedures of this manual; (4) disseminate appropriate system engineering documentation to cognizant SPO and SPO-related organizations for technical review; (5) chair meetings held concerning application of this manual; (6) approve the SEIP; and (7) oversee the administrative management of this manual. All organizational elements related organizationally or functionally to the SPO (e.g., civil engineering activity, propulsion, reentry vehicle, and AFCMD) that have a responsibility for any part of the system will adhere to and support the implementation of the system engineering process.

a. *Development of a System Engineering Implementation Plan.* The SPO will establish requirements for the SEG/R&T or GSE/TDC to develop an SEIP to implement the requirements and objectives of this manual (reference para. 8.0, exhibit 2).

b. *Establishment of Contractual Coverage.* The SPO will provide contractual coverage and memoranda of agreement as necessary for the tasks and levels of effort required to implement the responsibilities of the SEG/R&T or GSE/TDC, IAC or PC, and participating con-

tractors specified in exhibit 2. Contractual coverage will include exhibits 1 and 2 as implemented in the SEIP and appropriate 310-1 data items (attachment 1).

c. *Proprietary rights.* Extreme care must be exercised by the SPO not to disclose to third parties any proprietary information properly identified by the contractor in the system engineering data.

11. REVIEW REQUIREMENTS:

a. Integrated system engineering and technical direction of engineering efforts will be reviewed on a periodic basis to determine the technical adequacy of contractor efforts in meeting system requirements, including requirements for system effectiveness, reliability, maintainability, logistic supportability, life support/biomedical, human performance engineering, survivability vulnerability, producibility, procurability, and transportability. These technical reviews, to be conducted by the contractor, will in addition provide a basis for technical direction. The SPO will assure that all interested or affected commands (AFIC, ATC, and using commands) are invited to participate in these reviews in accordance with the system management policies, procedures, and responsibilities contained in AFR's 375-1, -2, -3, and -4. Reviews will be used by the SPO and SEG/R&T or GSE/TDC to evaluate and insure utilization of the system engineering documentation by the contractor as detailed in the contract work statement. The required reviews are categorized as follows: System requirements reviews, system design reviews, preliminary design reviews (PDR), critical design reviews (CDR), first article configuration inspection (FACI), acceptance test, and technical approval demonstration (TAD).

b. During phase 1B of the definition phase (reference fig. 5), scheduled reviews will be established by the SPO and SEG/R&T or GSE/TDC to evaluate the adequacy, completeness, and internal contractor application of the system requirements developed in the system engineering process. During these reviews, the SPO and SEG/R&T or GSE/TDC will insure (1) assignment of action items for disposition

of nonconformance identified as a result of evaluating system engineering documentation: (2) availability of detailed system engineering documentation to assess contractor progress in developing specifications, in selecting equipment and facilities, in defining intersystem interfaces, in establishing personnel and procedural data requirements, and in defining high-risk areas; and (3) documentation of engineering in a way to facilitate synthesis and integration of different contractor system and intersystem elements during phase 1C of the definition phase. During the definition phase, system requirements reviews and system design reviews will be the basis for initiating technical direction. During the acquisition phase, PDRs, CDRs, FACIs, acceptance tests, and TADs will be performed on a scheduled basis to evaluate the conformance of preliminary and detail design with the total system requirements stated in the System and Detail Specification.

c. During phases I and II (reference fig. 2), meetings will be required to resolve technical problems. These meetings will not involve a contractual change and will be classified as technical interchanges, which normally consist of followup actions generated by the scheduled reviews. A technical interchange may also be established and conducted by the IAC or PC as required to achieve integrated system engineering effort. Changes in requirements generated as a result of "in process" reviews will be formalized by technical directives. Technical directives will be communicated to the contractor by the SPO through the PCO. In instances where the technical or contract scope of the change is extensive, technical direction action may be concluded at a subsequent technical direction meeting. Such meetings will be considered an extension of the original "in process" review. Separate technical direction meetings may be necessary to transmit changes in requirements generated by the SPO and SEG/R&T or GSE/TDC or from higher headquarters. In all cases, technical interchanges and technical direction meetings will be conducted within the framework of system engineering established by this manual.

d. Reviews and evaluations of engineering progress will be made during the course of the

program to assure that system design integrity is maintained, technical deficiencies are isolated at the earliest point in time, and necessary changes are identified promptly. In general, the depth of evaluation would include (1) review of system and system segment performance, design, and test requirements including appropriate trade studies from which requirements were derived, (2) analysis and verification of intercontractor functional interfaces, and (3) review of performance and design requirements for and test results of complex contract end items (CEI) and components. Normally, the depth of evaluation would not include recomputation of contractor component/part reliability analysis, detailed structural analysis, and other detailed or standard analytical efforts; verification of material gage selection, standard component/part selection, and detailed functional and physical interfaces; evaluation of standard electronic component packaging and other standard design techniques; and evaluation of detailed circuit analysis, non-critical component/part performance, and design requirements and solutions. While the delineation of the entire range of actions encompassed by system engineering and technical direction reviews will be contingent upon the specific program under consideration, there are significant actions during the definition and acquisition phases which require specific attention. These are described below.

12. REVIEWS TO BE ACCOMPLISHED:

a. *System Requirements Review.* System requirements will be reviewed by the SPO and SEG/R&T or GSE/TDC when a significant part of the system functional requirements has been established and documented during the definition phase. This review will normally be made during the phase IB effort. Specific documentation to be reviewed, the technical depth, the tentative schedule, and number of reviews will be established by the SPO and SEG/R&T or GSE/TDC. For example, the system requirements reviews described in blocks 36 and 43 of exhibit 1 may be accomplished as part of the review called for in block 50. Reviews may result in technical or system management realignment to assure that the contractor's initial

technical interpretation of the contract is in line with program objectives. The contractors shall conduct these reviews of system requirements to insure development of technically definitive data.

b. *System Design Review.* The system design will be reviewed by the SPO and SEG/R&T or GSE/TDC when alternative design approaches, including corresponding test requirements, have been considered and the contractor has defined and selected the equipment, personnel, procedural data, and facilities required. The schedule for this review will be established by the SPO and SEG/R&T or GSE/TDC. The review will normally be conducted by the contractor when the definition effort has progressed to the point where the program requirements and design approach are more precisely defined. As a product of this review and evaluation, a technical understanding is to be reached on the allocation of requirements to (1) the system segments identified in the System Specification, and (2) the CEIs identified in Part I Detail Specifications. This review, together with phase IC evaluation and synthesis, provides the necessary basis for initiation of preliminary design in phase II (see fig. 2).

c. *Preliminary Design Review (PDR).* PDRs will be conducted for each contract end item. When a major integrating contractor is involved, the scope of the review shall encompass the participating contractors. Its purpose is to evaluate the progress, consistency, and technical adequacy of the selected design and test approach and establish compatibility with program requirements and preliminary design. PDRs shall be conducted by the contractor prior to starting detail design. The SPO and SEG/R&T or GSE/TDC will select certain items based on their complexity and will approve the agenda for the corresponding PDR and review the preliminary design. The basic documentation to be reviewed includes the requirements and test sections of the System Specification and the Part I Detail Specifications (prime equipment, facility, identification item, or critical components), and the Inventory Equipment Requirement Detail Specifications: accompanying drawings, schematics; interface

drawings; and other system engineering documentation. PDRs are to assure that the design approach in terms of equipment, personnel, procedural data, and facilities is an acceptable design solution to total system and contract end-item requirements. Considerations at the time of a PDR will include compliance with design and test activation criteria, evaluation of engineering breadboards and mockups, interface between CEIs, schedule compatibility, and design/development cost. PDRs will be conducted on an incremental schedule established by the contractor subject to approval by the SPO. Action items resulting from PDR will be made contractually binding on PDR participants by appropriate PCO action. Detailed requirements and procedures for conducting a PDR are specified in exhibit XIV, AFSCM 375-1.

d. *Critical Design Reviews (CDR).* CDRs will be conducted on each CEI to determine the acceptability of detail design, performance, test, and activation characteristics depicted by the design solution specified in the Part II Detail Specifications (prime equipment, facility, identification item, critical component), accompanying drawings, and other system engineering documentation. In some cases, the design solution may additionally be represented by mockups or breadboard models. These reviews are to be conducted by the contractor prior to complete commitment of design to production. As in PDRs, the SPO and SEG/R&T or GSE/TDC will participate in development of the agenda for the CDR, and review the designs considered significant or critical to overall system design, test, and activation. In establishment of the acceptability of a specific CEI, the prime requisite is to determine whether the recommended detail design and related test requirements adequately satisfy the established end-item design and test requirements, including interfaces with personnel, facilities, and other system equipment. The product of a CDR is SPO and SEG/R&T or GSE/TDC concurrence, rejection, or technical direction relative to complete commitment of a specific design to production. Action items resulting from CDRs shall be made contractually binding on the participants by appropriate PCO

action. CDRs shall be conducted on an incremental schedule established by the contractor subject to approval by the SPO and SEG/R&T or GSE/TDC. Detailed requirements and procedures for conducting CDRs are specified in exhibit XIV, AFSCM 375-1.

e. *First Article Configuration Inspections (FACI)*. FACIs will be conducted by the SPO and SEG/R&T or GSE/TDC on the first article scheduled for category II test or operational inventory suitable for systems integration, whichever is first. The FACI involves comparison of hardware with Part II Detail Specifications and accompanying drawings used in its production. It also includes determination of whether changes dictated by previous reviews have been made. Successful completion of the FACI establishes an approved product configuration baseline for the CEI and results in initiation of formal engineering change procedures (reference exhibit IX of AFSCM 375-1 and ANA Bulletin 445). After the FACI, there will be a contract action to accept delivery of the CEI. Detailed requirements and procedures for conducting FACIs are specified in exhibit XIV, AFSCM 375-1. In the case of communication-electronic facilities, an installation inspection is held after the FACI and the results are certified on an AFTO Form 88, "Communications-Electronics-Meteorological Facility Installation Inspection Certificate" (reference T.O. 31-1-8).

f. *Contract End Item and System Acceptance Test*. Acceptance tests will be held to demonstrate conformance of the CEI to the requirements specified within the applicable Part II Detail Specification. The result of a satisfactory acceptance test is formal acceptance of the CEI by completion of a DD Form 250, "Material Inspection and Receiving Report" (reference AFR 70-14). Subsequent to CEI testing, system level acceptance tests will be performed covering the assembly of end items into subsystems or the complete system.

g. *Technical Approval Demonstrations (TADs)*. Technical approval demonstrations are normally held in conjunction with the turnover of the system to the using command when multiple installations are involved. This review and accompanying tests demonstrates that

each CEI, each subsystem element, and the complete system meet the overall system requirements in the operational environment. The SPD in coordination with the using command determines the need for TADs on particular system.

13. DOCUMENTATION REQUIREMENTS. System engineering results are to be documented on forms covered by AFSCM AFLCM 310-1, following the intent and guidance of exhibit 1 to this manual. This requirement is applied conceptually by listing the required forms on the DD Form 1423, "Contract Data Requirements List." Total system requirements will be identified, defined, and specified on a progressive basis by means of this system engineering documentation. This documentation forms the basis for, evolves in consonance with, and ultimately becomes a product of, the design process. Normally the system engineering documentation required for delivery from a contractor does not go below the CEI level except as warranted for engineering critical components.

14. AIR FORCE MANAGEMENT CONTROL OF SYSTEM ENGINEERING. Engineering effort will be controlled by utilizing the procedures, requirements, documentation, and reviews described by this manual. The level of control to be exercised by the SPO will be progressively increased as a function of the level of design achieved. The level of design will be designated through the use of multiple sequential baselines established at major commitment points in the design process (i.e., for the definition of the system, a program requirements baseline; for the development of the system, a design requirements baseline; and for the production of the system, a product configuration baseline). Management control will be augmented by assuring that all procurement actions are based upon the hardware, computer program, facilities, personnel, and procedural data requirements resulting from the system engineering process defined herein. Positive management control of system engineering will be accomplished by the SPO using the documentation required in paragraph 13 and system requirements reviews, system design reviews, PDRs, CDRs, FACIs, acceptance tests, and technical approval demonstrations.

15. CONTRACTOR MANAGEMENT CONTROL OF SYSTEM ENGINEERING. Contractor management control shall be exercised in conjunction with the contractor's configuration management, internal drawing release, and specification control systems. System engineering documentation established by this manual will be utilized to develop, define, and justify proposed engineering changes controlled by AFSCM 375-1. System engineering documentation will normally not require further expansion once the CEI Part I Specifications and associated interface control documentation have been established except as necessary to support the generation of personnel subsystem information, technical manuals, and the maintenance analysis.

16. SYSTEM ENGINEERING CONTROL SUMMARY. A summary flow is presented in figure 2 to illustrate the use of the management process to control the system engineering effort. Figure 2 is divided horizontally into the following four bands: (1) documentation, (2) type of review, (3) contractual action, and (4) configuration management baselines. The documentation band portrays the major kind of data against which review actions will be conducted. The review band illustrates the type of review necessary. The contractual band shows the contract actions resulting from the review. The configuration management band shows the category of configuration baseline control applicable to or resulting from review. A summary description of each block follows:

a. *Block 1.* System requirements are reviewed incrementally against the program requirements baseline. System requirements reviews assure that total system requirements are being established. The result of these reviews is visibility into the contractor's development of requirements which contribute to satisfying total system objectives.

b. *Block 2.* The system design is reviewed against the program requirements baseline, particularly the System Specification. The system design review takes place when the system ele-

ments have been selected and design approaches have been more precisely defined. The result of this review is visibility into the contractor's selection of system elements and design approaches for satisfying system requirements.

c. *Block 3.* PDRs are conducted against the documentation of preliminary design to validate the approved design requirements baseline (block 2B) established by the Part I Detail Specifications. The PDR assures that (1) design and test requirements are valid, (2) the design and test approach representing the design solution is acceptable, and (3) functional interfaces between end items have been identified. The result of a PDR influences continuance of detail design in accordance with the approved design approach.

d. *Block 4.* CDRs are conducted against the detailed design information available: namely, the initial Part II Detail Specifications. The result of a CDR is a complete commitment of design to production: i.e., the contractor will produce equipment in accordance with the detail design presented at the CDR and modifications to that design which result from CDR. CDR actions in no way relieve the contractor from meeting his contract guarantees.

e. *Block 5.* FACIs are conducted to assure that the hardware matches the completed Part II Detail Specifications and accompanying drawings used in its production. The result of FACI establishes an approved product configuration baseline (block 5A) and is generally a prerequisite to contract action which accepts the delivery of the first article of hardware (block 6A).

f. *Block 6.* Acceptance tests are conducted on CEIs and subsequently the assembled system against accumulated specifications and drawings. The result of acceptance tests is DD Form 250 "sign off" (block 6A).

g. *Block 7.* Technical approval demonstrations are conducted to demonstrate overall performance of the assembled system in its operating environment. The result of demonstration is formal turnover and acceptance of the system by the using agency.

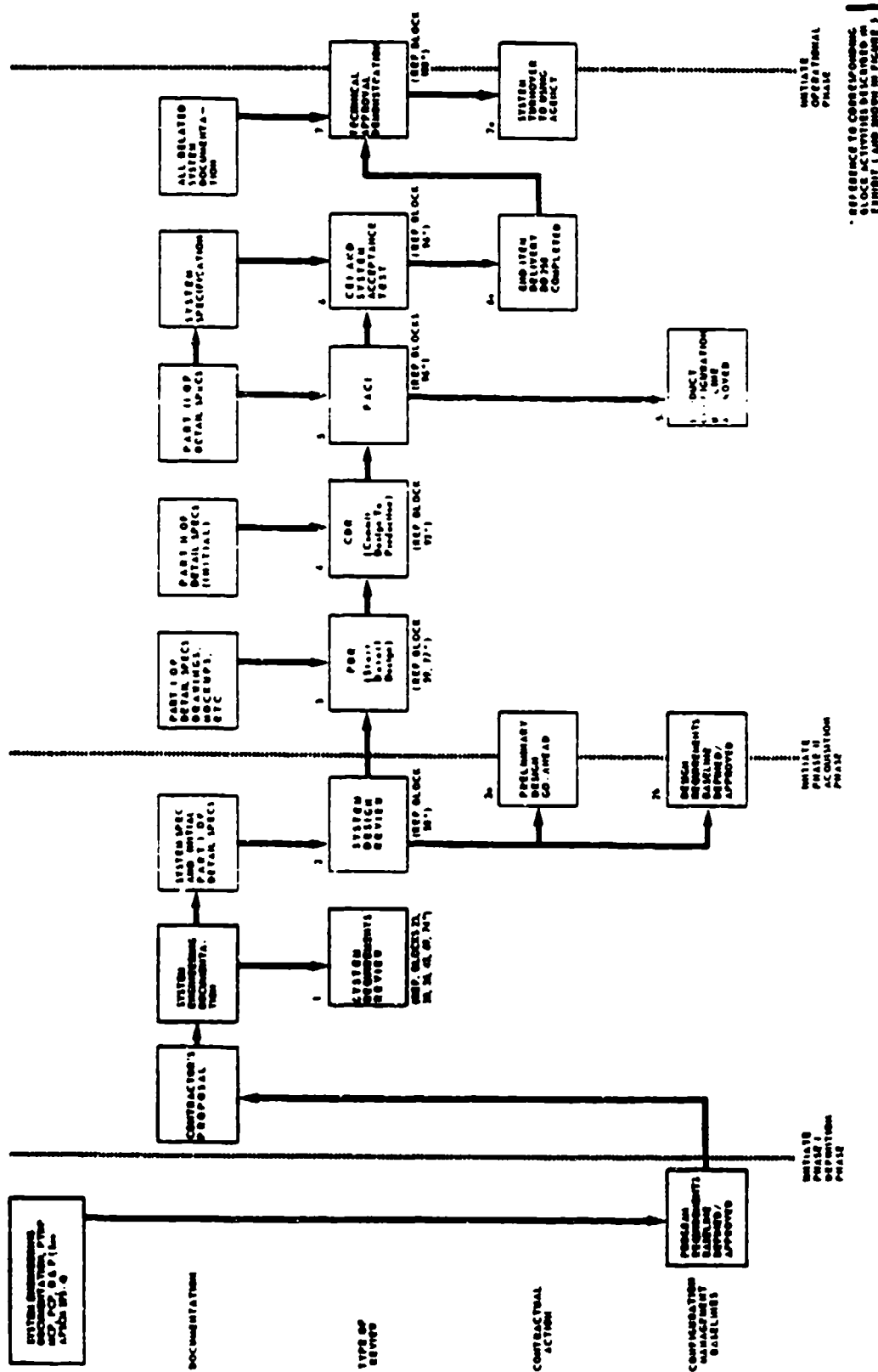

Figure 2. System Engineering Control Summary.

Chapter 5

CONCEPT

17. FUNDAMENTAL CONCEPTS. The three fundamental concepts on which this manual is based are:

a. *Baseline Management.* The intent of this manual is to establish and maintain a system of documentation and positive definition and control between interfacing AF requirements, design requirements, and design solutions of the elements within a system (intrasystem) and between systems (intersystem). This is achieved by means of a concept of establishing and managing the baselines through the use of uniform documentation, engineering reviews, and standard procedures which can insure an orderly transition from one major commitment point to the next in the system engineering process. Baseline management consists of establishing the program requirements baseline, the design requirements baseline, and the product configuration baseline (reference AFSCM 375-1). These three baselines serve as engineering reference points and represent the progressive and evolutionary development of specifications and associated data. The specifications are a forcing function upon design, and since they progress from general requirements to detail requirements, they provide a level of control which is initially of broad scope and is eventually narrowed to be more restrictive as the design becomes more definitive. A constant closed-loop relationship must be maintained between established system and design requirements and design effort, thereby assuring that the design effort is at all times purposefully directed to meet, rather than exceed or fall short of, total AF system requirements.

b. *Design Process.* Fundamentally, the process involved in developing any design is a pattern of common logical steps. The process described herein defines these steps within a framework of engineering management. To the maximum extent practicable the require-

ments of this document must become an integral part of the design effort rather than a parallel or reporting effort which duplicates the normal design effort.

c. *Functional Basis.* An essential element of the process of system engineering is the employment of a functional approach as a frame of reference for the identification of initial requirements at each design level of the system. By translating AF requirements into the operations, maintenance, activation, and test functions, which must be performed by the elements of the system, a common reference point or functional base is established for developing the elements of the system. This functional approach can assure that definition is on a total system basis in full recognition of all involved elements; the possibility of omitting essential elements is reduced; a means for relating hardware, computer programs, facilities, personnel, and procedural data is provided; a clear frame of reference for requirements is established and maintained; and communication between personnel assigned to various system elements is clearly established.

(1) The application of the functional approach to various types of systems results in the logical definition of system elements. Figure 3, reading from left to right, illustrates the system elements for typical system programs. While system program types can vary widely, it is necessary that all system programs initially identify the primary mission functions and requirements, and then identify the functions and requirements for supporting the mission as the only basis for defining total requirements and selecting system elements.

(2) For a typical manned space system, the initial effort is toward developing the flight mission functions in order to define requirements for aerospace vehicle equipment (AVE) and astronauts. Such operations functions may be

"Achieve orbit," "Perform experiments," "Achieve rendezvous," "Recover mission data," and "Recover personnel." These initial functions would then serve as a basis for developing more detailed operations functions in order to identify more detailed requirements and any needed trade-off studies. For example, trade-offs might be conducted against the function "Recover mission data." Alternative approaches might involve either recovering an entire spacecraft or recovering ejected capsules from the spacecraft.

(3) As system engineering progresses, decisions are made regarding means by which functions can be met. These decisions, in turn, form the basis for subsequent further indentures of functions. For example, if the capsule method is selected, this choice will generate additional requirements and possible trade-offs with respect to means for ejecting capsules. Following the consideration of all the necessary functions at the initial level of indenture to define the flight mission functions the process progresses to the next step. In the case of the manned space program, this step would consist of identifying the functions generating requirements which would be met by operating ground equipment, technical support facilities and personnel required to conduct a launch. At this point, required trade-offs would be conducted with respect to selecting the types of operating ground equipment (OGE) necessary to satisfy the required functions. For example, trade-offs might be conducted between automated and manual checkout methods, various tracking systems, and means of communicating with spacecraft.

(4) Maintenance functions would be de-

veloped in much the same manner and in some cases concurrently with the development of operations functions. Maintenance requirements should be analyzed as early as feasible (i.e., once the equipment to be maintained has initially been defined) due to their influence on the final definition of total requirements for AVE, OGE, operations facilities, and operations personnel.

(5) Activation and test functions would be developed on a concurrent basis throughout the definition of system elements. That is, as system elements are defined, the analysis to define the related test and activation requirements (including, in selected areas, production requirements) is accomplished. The resulting test and activation requirements will necessitate the definition of supporting test equipment, special activation handling equipment, transportation equipment, test and activation personnel, and training.

(6) In the case of an electronic reconnaissance system, the initial indenture would consist of the functions necessary for gathering the electronic information in various forms dictated by the requirements of the system. For example, gross operational functions might be "Detect electromagnetic transmissions," "Collect electromagnetic intelligence data," "Reduce intelligence data," and "Interpret intelligence data." Initial trade-offs would select the various types of prime mission OGE including computer equipment and programs, available facilities, and personnel required to satisfy the above-listed functions. The maintenance, activation, and test functions would be derived from subsequent system engineering of these initially selected system elements.

Chapter 6

SUMMARY OF SYSTEM ENGINEERING MANAGEMENT PROCESS

18. FUNDAMENTAL CYCLE OF THE SYSTEM ENGINEERING MANAGEMENT PROCESS. This cycle consists of the four steps shown in figure 4. The process is a method for defining the system on a total basis so that the design will reflect requirements for equipment, computer programs, facilities, procedural data, and personnel in an integrated fashion. It provides the source requirement data for the development of specifications, test plans, and procedures; and the backup data required to define, contract, design, develop, produce, install, checkout, and test the system.

a. Step 1. The first step of the process is started by identifying system requirements such as those contained in a specific operational requirement (SOR) and translating these requirements into basic functional requirements, i.e., statements of operation. These requirements are presented in the form of top and first level functional flow block diagrams (reference atch. 1) to portray the sequential and parallel interactions of functions. At this point, the significant characteristic is a functional design

and no mention is made of hardware, circuits, or devices. This does not mean that design solutions do not occur. Preconceived notions which shape design solutions will undoubtedly exist. The danger lies not in having the notions but in being unwilling to discard them in the face of evidence indicating their unsuitability. It is not necessary to proclaim a solution at this point as *the* solution, but simply to understand its use as a first hypothesis for helping to mold the eventual solution.

b. Step 2. These functions and associated criteria are analyzed and translated into design requirements as the second step of the process. The design requirements are comprised of all requirements, including design constraints, that have a bearing on the functions being analyzed. Equally important, the design requirements contain sufficient technical detail to provide the criteria for: (1) designing equipment and/or computer programs and defining facility equipment and intersystem interfaces, and (2) determining requirements for personnel, training, training equipment, and procedural data.

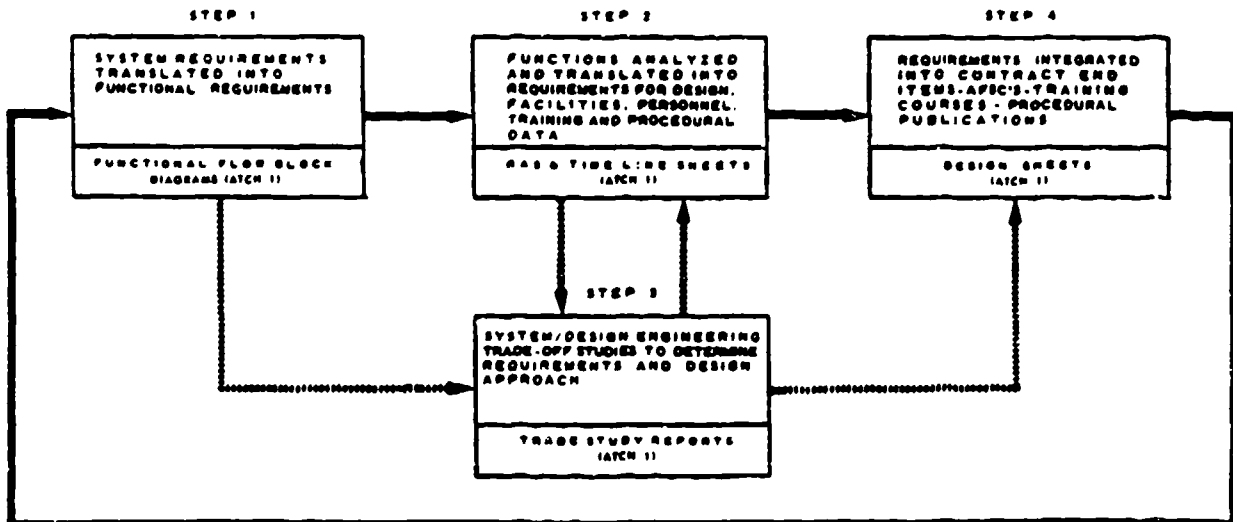

Figure 4. Fundamental Cycle of the System Engineering Management Process.

These requirements are recorded on requirements allocation sheets (RAS) and timeline sheets (reference attachment 1).

c. Step 3. The third fundamental step consists of system/design engineering studies which are performed concurrently with step 2 and step 4 to: (1) determine the selection of alternate functions and functions sequence, (2) determine the design, personnel, training, and procedural data requirements imposed by the functions, (3) determine the best way to satisfy the design requirements, and (4) select the best design approach for integrating the design requirements into CEIs of equipment and/or computer programs. The design* approach is detailed to the point necessary to satisfy the level of requirements listed on the RAS. Normally, these studies will involve trade-offs where the data are in the form of schematic block diagrams, outline drawings, intersystem and intrasystem interface requirements, comparative matrices and data defining the reasons for selecting the approach, including cost considerations which influence the design approach selection. The scientific tools of system/design engineering studies such as probability theory, statistical inference, simulation, computer programming, information theory, queuing theory, servomechanism theory, psychotechnics, cybernetics, mathematics, chemistry, and physics are not discussed here. Though they are vital to and part of the system/design engineering studies, it is not essential to discuss these basic scientific tools in order to prescribe the requirements for effective system engineering management. When required, system/design engineering studies are recorded in a Trade Study Report (reference attachment 1).

*NOTE: The term "design" applies to many levels and points in time of defining and acquiring the system. For example, early design at the system level results in schematics showing the functional interface between end items, whereas at the time of acceptance the design of the system would be represented by all end-item top drawings. The design approach is to be distinguished from the design solution. The design solution would include the top drawing whereas the design approach, concerning physical aspects, for example, would require a control set function to be performed by three chassis: signal conditioning chassis (40 lb.), power switching chassis (50 lb.), and power distribution (30 lb.).

d. Step 4. Utilizing the design approach determined from system design engineering studies, the design requirements developed in step 2 are integrated into CEIs. The contract end-item performance, design, and test requirements are recorded on a design sheet (reference attachment 1). These requirements shall sufficiently define engineering information, utilizing numerical values with associated tolerances, to provide criteria for the detail design, development, and test of the contract end item. The design sheets document the "design to" and "test to" requirements for contract end items and subsequently become sections three and four of the corresponding Part I Detail Specification (reference AFSCM 375-1). The personnel, training, training equipment, and procedural data required are based on the cumulative effect of the line entries in the RAS. Just as the design requirements are to be grouped into CEIs, the human performance tasks required are grouped into Air Force specialty codes (AFSC), the training required is grouped into courses, and the procedures are grouped into technical manuals, technical orders, and other procedural publications. The design sheet and RAS provide the basic data for the preparation of the Qualitative and Quantitative Personnel Requirements Information (QQPRI), Training Equipment Planning Information (TEPI), and procedural data lists. Outputs of step 4 are used to (1) determine intersystem interfaces, (2) determine additional requirements and functions resulting from the technique or device selected which in turn becomes the basis for second-level functional flow block diagrams, and (3) provide feedback to modify or verify system requirements and the functional flow block diagrams prepared in step 1.

19. ITERATION OF THE PROCESS. When the fundamental cycle of the system engineering process documented in top- and first-level functional flow block diagrams, RASs, Trade Study Reports, and design sheets has been completed, the second-level functions are identified and the fundamental cycle is repeated. The same procedure is followed at any additional levels required to define and design the system. Some functions may not require separate diagram levels and may be included in a higher level

diagram. There are interactions and feedbacks between levels as the cycle is repeated. For an example of the fundamental cycle at the third level, reference paragraph 1.0, attachment 2.

20. DOCUMENTATION:

a. Design sheets, together with the RASs, functional flow block diagrams, and Trade Study Reports, serve as the basic documentation against which engineering is evaluated during the definition phase. The design sheets are incorporated into the Part I Detail Specifications used in engineering evaluations, such as PDRs, CDRs, and FACIs accomplished during the acquisition phase. The system engineering management documentation also provides the essential elements for other program management actions. For example, functional flow block diagrams, RASs, end-item maintenance sheets, calibration requirements summaries, and maintenance loading documentation are of prime importance in developing logistic support requirements for the program. Identification and definition of CEIs on design sheets provide the source for specification tree, for PERT/cost program breakdown structure, for procurement action, and the basis for test planning. The system engineering process cannot, and obviously will not, make engineering decisions itself, but it does provide a basis for making the decisions and provides a discipline for engineering and development of systems.

b. There are other factors which must also

be defined as part of the system engineering process. For example, reaction times, maintenance downtime, and maintenance functions required must be considered in determining design requirements and selecting the design approach. The detailed system engineering documentation involves time-line sheets, facility interface sheets, maintenance sheets, and other documentation described in exhibit 1 and attachment 1 to insure consideration of all factors. In some cases, summary sheets for the determination of power-load schedules, electrical input/output signals, monitor and checkout requirements, etc., will be required. Certain systems may not require the utilization of every data item described in exhibit 1 and attachment 1 or may require modification of the data item and documentation. In some cases, additional documentation may be required. In the case of computer programs, documentation tailored to computer program needs may be necessary; e.g., the format of the design sheet would not be appropriate for specifying the design requirements for computer programming; however, some document serving as a design sheet is required. The application of the documentation requirements described herein must be made on a system-by-system basis and specific documentation requirements defined in the contract. In each case, the requirements specified herein will be applied to the system under consideration via the SEIP of the PTDP (reference para. 8.0, exhibit 2).

Exhibit 1

PROCEDURES FOR SYSTEM ENGINEERING MANAGEMENT

1.0 INTRODUCTION. This exhibit establishes the requirements for the step-by-step procedures to be followed in implementing system engineering management during the latter part of the conceptual phase, through the definition and acquisition phases, and the early part of the operational phase. It specifies the required system engineering documentation and prescribes the relationships between documentation, engineering, design reviews, specifications, baselines, and major commitment points. Figure 5* is a sequential actions diagram on a relative time base beginning with issuance of the SOR/CSR/ADO extending through the early part of the operational phase. This diagram portrays system engineering actions to be accomplished by the SPO and GSE/TDC or SEG/R&T and contractors. Hereafter the term "SPO" refers to the SPO and the GSE/TDC or SEG/R&T. The actions identified as octagonal blocks in figure 5 shall be accomplished by the contractors. The actions to be accomplished by the SPO are identified as rectangular blocks.

1.1 Diagram of the System Engineering Management Process. The flow shows a specification line, a system design line, an operations design line, a maintenance design line, and a test support line containing major interacting actions required in conducting system engineering. The outputs, phases, baselines, and SPO

system engineering technical direction review points are identified on the bottom of the flow. A complete list of the documentation required by this manual appears at the beginning of figure 5. The circled numbers appearing below each block identify the documentation associated with the block. There is a continual interaction between lines of actions, and while the actions appear as step functions, they are in fact points on a continuum. Figure 5 provides the contractor with a "road map" of system engineering management actions and specifies the formal points for SPO management review of the system as it is being defined, designed, and developed. The following paragraphs describe and explain the requirements of each block in figure 5.

1.2 Compliance With Related Military Specifications. The implementation of the engineering design process described herein will result in compliance with a substantial portion of the military specifications identified in the list given below. Listed with the specifications are numbers of specific paragraphs which will be satisfied. Separate and parallel efforts shall not be expended in complying with the requirements contained in these paragraphs of military specifications. Subparagraphs are not included unless specifically listed; e.g., listing 3.1.5 does not include 3.1.5.1, etc.

MIL-P-25906 (USAF) (para. 3.1 and all subparagraphs thereto. Paras. 3.4.2f and 3.4.4.b.(1)).

MIL-D-26229A (USAF) (para. 3.1.5, app. 1.2, and para. 4-1.4 of app. 1.4).

MIL-M-26512C (USAF) (paras. 3.4, 3.4.2, 3.5.1.a, 3.5.1.b, 3.5.1.c, 3.5.1.h, 3.5.1.i, 3.6, 3.7, 3.8, and 3.9).

MIL-H-27894A (USAF) (paras. 3.1.1.a, 3.5, 3.5.1, 3.5.2, and 3.6).

MIL-S-38180 (USAF) (paras. 3.2.4, 3.2.4.1, 3.2.4.2, 3.2.4.3, 3.2.6, 3.2.6.1, 3.2.6.2., 3.2.6.3, 3.2.6.3.1, and 3.2.6.3.2).

Procedures for the Development of a Cockpit Subsystem and Accomplishment of Systems Integration, 10 Mar 1958.

Data, Qualitative and Quantitative Personnel Requirements Information (QQPEI), 14 Apr 1961.

Maintainability Program Requirements for Aerospace Systems and Equipment, 13 Dec 1963.

Human Engineering Requirements for Aerospace Systems and Equipment, 9 Jan 1963.

Safety Engineering of Systems and Associated Subsystems, and Equipment; General Requirements for, 30 Sep 1963.

*For convenience, figure 5 is placed as the last page in the manual.

2.0 CONCEPTUAL PHASE REQUIREMENTS.

Block 1. SOR/OSR/Specified ADO Formulated and Issued:

a. A significant result of research, advanced development, and exploratory development achieved during the conceptual phase is a specific operational requirement, an operational support requirement, or an advanced development objective (hereafter referred to as SOR/OSR/ADO) which is issued during conceptual transition. National defense objectives, intelligence estimates, threat information, foreign technology, conceptual studies, and feasibility studies provide military planning organizations with the information necessary to determine the requirement for a new capability. When this capability includes the need for a new system and a qualitative operational requirement (QOR—reference AFR 37-3) has validated the requirements for a new system, then HQ USAF issues an SOR/OSR/ADO.

b. An SOR/OSR/ADO is issued when the military value and the technical and economic feasibility of the proposed system have been established. There is usually some uncertainty about these factors throughout the entire conceptual phase, and consequently some judgment must be made concerning the relative advantages of issuing an SOR/OSR/ADO versus conducting further conceptual system planning studies or feasibility studies. An SOR provides conceptual guidance for all aspects of the system program, outlines the specific parameters, and describes the required characteristics of the system to be defined and developed to fulfill a near-term operational need. A specified ADO is similar to an SOR except that its purpose is to fulfill a long-term operational need (reference AFR 375-1).

c. Normally, an SOR or specified ADO will contain (1) a statement of the military capability required, including reasons for the requirement and background information; (2) if applicable, an enemy effectiveness estimate; (3) a description of the friendly environment including deployment requirement, site locations, support requirements, integration with other systems, security requirements, and self-sufficiency and warning requirements; (4) a concept of

operation maintenance and logistic support, including positive system mission control, dispersal requirements, manning and manpower requirements, personnel facilities requirements, and materiel support requirements; (5) operational performance including, as applicable, readiness requirements, survivability/vulnerability, system effectiveness requirements, penetrability, percentage of kill, damage limitations, payload weights, specific impulse, range, computer programs required, warhead yield requirements, system safety requirements, reliability requirements, communication requirements, altitude requirements, orbit requirements, take-off acceleration, take-off thrust, velocity, in-commission rate, training requirements, specific functions to be performed, type of displays required, number of installations, etc.; (6) estimated cost and schedule; (7) the date when the system is to be available; and (8) a reference list of supporting and related trade studies, including current available DOD projects that address the same threat. The SOR/OSR/ADO establishes the fundamental system requirements which are necessary to begin the system engineering process.

Block 2. Identify, Review, and Select Source Documentation. The initial SPO function in the system engineering process will be to identify, review, and select the documents which have a direct bearing on the system. These documents will consist of the SOR/OSR/ADO, conceptual study reports for the system or similar systems, and specialized data relating to a particular aspect of the system: e.g., use of laser devices or fuel cells and any other documents which will aid in establishing the basic system requirements. The SPO will prepare and maintain a list of these documents and will provide copies of this list to contractors with the statement of work (SOW) for phase 1B (reference AFSCM 375-4).

Block 3. Develop Gross Functions (Operations, Maintenance, Test, and Activation).

a. An initial step in the system engineering process consists of formulating a functional description of the system. This functional description represents a gross level portrayal of the functions which must be met to satisfy total

system requirements and represents the genesis of detail requirement determination. The purpose of this step is to assure that (1) continuity is maintained between system requirements and engineering effort; (2) initial critical decisions in system formulation are documented and can be retrieved as necessary; (3) total system requirements are considered during initial system formulation stages; (4) a means is provided for maintaining positive control of gross functions down to detail equipment functions; and (5) interfaces between systems will be defined; e.g., interfaces with a command and control system, early warning system, existing booster system, or existing aircraft.

b. In developing the gross functions, a clear relationship must be maintained between the basic system requirements stated in the SOR/OSR/ADO and the constraints emanating from products of previous research and technology actions. Thus, requirements of the SOR, JSR/ADO (block 1) and the source documentation (block 2) serve as the basic inputs for the formulation of the gross functions. Changes may originate as the result of changes in basic operational requirements or as a result of changes caused by design iterations which delete or add functions. In either case, a closed-loop relationship must be constantly maintained between basic system requirements and the gross functions. A description of the development of gross functions from the basic system requirements follows.

c. The basic system requirements identify one of the typical system programs shown in figure 3. Within one of these frameworks the basic system requirements will be translated into gross operations, maintenance, test, and activation functions (reference para. 4 for explanations of the functional categories). These functions are then interrelated and flowed in sequence as the top-level functional flow block diagram for the system. Hereafter, functional flow block diagrams are referred to as functional diagrams. The top-level functional diagram portrays the gross functions which must be accomplished by the system program to meet the system objectives.

d. Examples of top-level functional diagrams are shown in paragraphs 2.0, 3.0, and 4.0 of at-

tachment 2. In the case of a manned space system, typical gross operations functions for the primary mission might be (1) Prepare spacecraft and launch facility for launch, (2) Launch spacecraft, (3) Perform space mission, and (4) Recover personnel and mission information. In the case of an electronic system, typical operations functions for the primary mission might be (1) "Detect and track all space objects within defined zone of apprehension," (2) "Identify mission of each object, compute apparent track and target, compose and dispatch warning messages and information concerning available protective measures," and (3) "Display continuous status of space objects and defensive weapons and provide display of other pertinent data when called for." In both instances above, the operations functions must then be supported by maintenance functions. Test and activation functions are required to identify production, acceptance, training, and test functions of a system. Production function development should be accomplished on a selective basis to avoid redefinition of standard factory operations and techniques.

e. As described in chapter 5, these functional terms are vital and serve as group headings for translating system requirements into subfunctions. For example, subfunctions of the gross function, "Launch spacecraft," might be "Load fuel, load oxidizer, calibrate guidance, load breathing oxygen," etc. The level of functions to be identified at this early point will depend upon the degree of available knowledge of the system, the degree of information required to prepare the preliminary technical development plan (PTDP), and the amount of effort programmed for definition phase IA expansion of the PTDP. However, as a minimum, the system operations, test, activation, and maintenance functions will be identified to a level of detail sufficient to define the concepts for operation, maintenance, and category I and category II test and activation. The test concepts thus developed will provide inputs to the initial category I and II test plans described in AFSCM 375-4. At this point, it is expected that first-level functions will be developed to provide first-level functional diagrams for each gross function in the top-level functional dia-

gram. Functional diagrams will be numbered to preserve continuity of functions and will be depicted in the format shown and specified in attachment 1.

f. The functions identified at this point will not be limited to those necessary for operation of the system, but must include consideration of maintenance implications on system design. Maintenance planning shall be considered at this point to preclude the possibility of developing a technically feasible system from an operations viewpoint, before it is determined that the maintenance implications will prove costly or impractical or prevent the system from performing reliably. Maintenance functions identified at this point will reflect the consideration of allowable in-commission rates, downtime allocations, and available maintenance resources. Developing first-level functional diagrams for the gross maintenance functions will be dependent upon the amount of AVE and OGE identified in the SOR/OSR/ADO. In many cases, only an estimate of the first-level maintenance functions can be made at this point, and not until block 34 will there have been sufficient preliminary engineering to complete first-level maintenance functional diagrams. The same situation applies to first-level functional diagrams for test and activation gross functions. Functional diagrams shall be used as a basic starting point for developing block diagrams for effectiveness factors such as reliability, maintainability, etc.

g. Functional diagrams portraying the functional base for determining civil, structural, and architectural requirements will normally be first- and second-level functional diagrams. For an example, reference paragraph 5.0, attachment 2.

h. A careful review of the top- and first-level functional diagrams will be conducted to assure that continuity between flows has been maintained and that trade-offs have been made between alternate functions and flows. For example, a computing function required for status monitoring may be adequately combined with a computing function required for missile guidance. The functional diagram methodology provides a technique for systematically trading off a number of alternate functions and flows

which will meet system requirements. These trade-offs, as well as other trade-offs, require system/design engineering studies to determine which set of functional diagrams will best meet the system requirements in terms of cost, time, and performance. The system/design engineering studies are described in block 8. At this point, these studies involve determining predicted design solutions and requirements for facilities, people, and procedural data for each alternate function or flow. These predicted solutions and requirements are then compared in terms of cost, time, and performance.

i. A maximum effort will be devoted to the preparation of functional diagrams to insure their completeness and accuracy. The basic system requirements must be translated into functions in the form of discrete statements of an objective or standard. For example, sub-functions of the gross function "Flight mission" might be "Provide guidance signals," "Control vehicle attitude," and "Display data."

j. Caution should be exercised to avoid using preconceived equipment configurations as the basis for developing functions. This does not mean, as discussed in chapter 6, that design solutions are totally ignored but, rather, that the top- and first-level functional diagrams will be limited to pure functions in order to provide maximum latitude for allocating functions to the optimum combination of equipment, facilities, and personnel. An exception, however, is the case where the basic system requirements specify the utilization of certain equipment configuration and personnel.

Block 4. Determine Design Requirements (Operations, Maintenance, Test, and Activation).

a. Concurrently with the development of the first-level functional diagrams, the functions determined above are studied for the purpose of translating the functions into initial design/performance requirements and establishing interfaces with other existing or to be developed systems. A part of the study was devoted to conducting trade-offs to determine the selection of alternative functions and function sequences as specified in block 3. Once the alternatives are selected, the study effort continues, analyzing the functions to determine the design re-

quirements to be satisfied by a combination of system elements: i.e., equipment, personnel, facilities, and procedural data. Reference attachment 1, for Trade Study Report requirements.

b. The design requirements should be defined to a level of technical detail which will allow preliminary recommendations for the basic method of accomplishing the gross functions: i.e., some combination of equipment, including computer programs, personnel, and facilities. For example, the recommended basic method for the first-level function "Enable encoder" under the top-level function of "Perform missile launch" would be to do it manually; whereas, the recommended method for the first-level function "Transmitter launch code" under top-level function of "Perform missile launch" would be to do it automatically. The preliminary recommended method for first-level field maintenance function (e.g., "Perform G&C computer controlled calibration sequence") under the gross function of "Support base maintenance" would be to perform it automatically; whereas, the first-level field maintenance function of "Sequence G&C system to calibrate mode" would be to perform it with a man-equipment combination.

c. The design requirements generated from the gross operation, maintenance, test, and activation functions shall include preliminary requirements for facilities. For example, the initial design requirements for one set of top- and first-level functions may be satisfied by selecting underground facilities in order to meet a system survivability requirement; whereas, another set of functions may call for above-ground facilities in order to meet the same system survivability requirement. As these facility requirements are being developed, they will be evaluated for their criticality. Those requirements which are critical to direct mission accomplishment or safety or are dependent on stringent state-of-the-art technology will be allocated to technical support real property (TSRP). The noncritical facility requirements will be allocated to nontechnical support real property (NSRP) design requirements. Preliminary requirements for facilities will be defined to the level of detail necessary

to identify the total facility subsystem concept. Industrial facility requirements will be identified in gross terms, sufficient to allow planning and evaluation of existing resources.

d. Facility system engineering (FSE) will determine preliminary site requirements and evaluate existing facilities or the need for new facilities in order to perform the top- and first-level functions. In determining preliminary site requirements, the facility system engineer must consider (1) the environmental conditions, i.e., operational (overpressure, thermal, etc.) and natural (arctic, tropic, dry, humid, etc.); (2) mobility requirements, i.e., fixed (above or below ground in flat or mountainous terrain) or mobile (air, rail, truck, etc.); (3) deployment concept including use of existing base and availability of existing facilities or deployed in isolated areas that are inaccessible; (4) special security requirements whether manned or unmanned; and (5) hazard criteria. These factors should be contained, at least conceptually, in the documents identified in block 2.

e. In translating functions into design requirements, put emphasis on stating requirements in quantified or well-qualified terms. The analysis of functions to determine the design requirements shall be documented on the requirements allocation sheet (RAS) and supporting trade study reports and timeline sheets (reference attachment 1, for detail requirements).

f. The initial design requirements will, where feasible, be in terms of (1) the purpose of the function; (2) the parameters of design (i.e., input and output values and allowable tolerances); (3) requirements which constrain design such as frequency allocation, power, physical, interface, time, environment, use of standard parts; and (4) requirements for system effectiveness, reliability, human performance, safety, security, maintainability, and transportability. Statements which merely repeat the function title will not be included. For example, for the function "Transport transtage to launch area," the RAS should not read "Provide a means to transport the transtage to the launch area." The design requirements should include specific information relative to transportation distances and prob-

lems peculiar to the modes of transport such as physical characteristics of the transtage, environmental sensitivities of transtage, etc.

g. A major objective of concurrently developing first-level functions and determining the corresponding design requirements is to eliminate nonproductive or nonattainable system design configurations, test concepts, activation concepts, and maintenance concepts. Only the best attainable alternatives should be pursued to the conclusion of having documentation prepared for use in developing the PTDP.

h. The functional diagrams and the functional requirements, including time relationships, identified on the RAS, trade studies, and time lines, shall define the basic functions for deriving (1) system, subsystem, and CFI, (2) as applicable, component reliability requirements and predictions, including mathematical models and reliability inputs to system effectiveness models; and (3) overall system effectiveness models, including availability, repairability, serviceability, and mission reliability considerations. At this point, this functional framework will be gross. Therefore, system effectiveness parameters can normally be developed only to define overall reliability, availability, etc., requirements. As lower level functions and related hardware and personnel requirements are developed, the reliability, maintainability, availability, etc., parameters shall be further defined and utilized as a basis for specific system effectiveness requirements and prediction development.

Block 5. Provide Inputs to Preliminary Technical Development Plan (PTDP).

a. This block represents the culmination of the action directed toward the preparation of engineering information that forms an essential part of the PTDP (reference AFR 375-5). Specific inputs include (1) functional diagrams depicting the functions which must be performed to meet the requirements specified by the SOR/OSR/ADO; (2) engineering descriptions of the functions; (3) gross solutions to system requirements in terms of the design requirements which must be met to satisfy defined functions; (4) predicted equipment configurations based on conceptual phase studies; and

(5) trade-offs considered and areas requiring further exploration with emphasis on high risk, technical, cost, or schedule areas.

b. The summarized engineering information provided for the PTDP forms an engineering base against which subsequent engineering decisions must be evaluated. The engineering information provided in the PTDP defines the technical portion of the program requirements baseline. Where engineering results dictate changes which do not fall within the parameters of the established base, the approved PTDP must be updated to reflect the new parameters. Since the PTDP is the governing authority for the program during the definition phase, it is essential that resulting engineering effort be responsive to, become an integral part of, and be constantly assessed in light of the PTDP. Examples of the specific types of inputs provided to the PTDP are:

(1) *High Risk Areas.* The "Program Summary" section of the PTDP should include high technical risk areas identified by engineering. These areas should be related to the schedules and test portions of the PTDP; i.e., extensive testing which is time consuming might be required for a high risk technical area.

(2) *Functional Diagrams.* Functional diagrams should be included as part of the "Acquisition" section of the PTDP to outline requirements in functional terms, as well as engineering descriptions of the functions in terms of design requirements. This information serves to scope the design effort required.

(3) *Equipment Configuration.* Information concerning the configuration of equipment is used for production and logistic planning and serves as the basis for the information contained in the "Acquisition" and "Logistics" sections of the PTDP; e.g., what are the tooling requirements and how is the program to be logistically supported?

(4) *Activation and Test Concepts.* These concepts are used as a basis for further expansion into section 4 of the initial System Performance/Design Requirements General Specification (reference exhibit I of AFSCM 375-1).

(5) *Mission Profile.* Where appropriate for the type of system to be developed, a mission profile shall be prepared from the flight

10 March 1966

AFSCM 375-5

mission functions and related functional requirements depicted on the functional diagrams, RASs, trade study reports, and time-line sheets.

c. For electronic systems, the engineering inputs to the PTDP shall establish the concept and the intersystem integration requirements necessary to insure an early integrated and compatible hardware computer program capability.

d. It is essential that engineering results are constantly reflected in the PTDP as the program proceeds downstream.

3.0 DEFINITION PHASE REQUIREMENTS

3.1 Phase IA:

Block 6. Expand Operations, Maintenance, Test, and Activation Functions.

a. An initial step during phase IA of the definition phase will be to expand the operations, maintenance, test, and activation functions previously prepared. The SPO will accomplish this action in preparation for the issuance of the RFP.

b. The requirement is to expand top and first-level functional diagrams previously prepared to reflect changes resulting from the approved PTDP and information acquired while awaiting approval of the program requirements baseline. The level of definition attainable at this time will vary; however, it is anticipated that as a minimum, second-level functional diagrams should be prepared. Examples of second-level functional diagrams appear in paragraphs 3.0 and 5.0 of attachment 2.

c. Functional diagrams will serve to structure the System Performance/Design Requirements General Specification (hereafter referred to as System Specification). Since the System Specification includes the requirements for subsystems such as propulsion, guidance, and communications and overall activation and test requirements, it will be necessary to prepare functional diagrams to the level necessary for establishing the parameters of these subsystems. As preliminary design information becomes available, appropriate changes will be made to the functional diagrams. Specific consideration will be given to functional diagrams depicting alternate functional solutions for high technical, cost, and time risk areas. Trade studies will be required to select between al-

ternate flows. Alternative functional diagrams will be maintained until decisions regarding the best design solution can be made.

d. The functions selected and the functional diagrams prepared are to be direct responses to system requirements rather than to preconceived equipment solutions.

Block 7. Determine Additional Design Requirements for Operations, Maintenance, Test, and Activation.

a. The expanded functions will be studied to translate them into design requirements, including performance requirements. The design requirements should be to a sufficient level of technical detail to provide preliminary recommendations for the method of accomplishing the function. This analysis of functions will be documented on the RASs and time line sheets.

b. Blocks 6, 7, and 8 are enveloped with a slight stepping of the blocks. The stepping is to graphically portray that the three activities are initiated sequentially, and the envelope is to indicate that the accomplishment of these activities evolves concurrently.

c. The design requirements will be quantified or well qualified terms expressing the (1) purpose of the function; (2) the parameters of design (e.g., input and output performance values and allowable tolerances); (3) requirements which constrain design such as power, physical, interface, environment; and (4) requirements for effectiveness, reliability, human performance, safety, operability, maintainability, transportability, and survivability/vulnerability.

d. In some cases, it will be necessary for the SPO and the AFSC division civil engineering activity to conduct preliminary site surveys to evaluate existing facilities, including transportation facilities, or the need for new facilities. The results of these site studies will aid initial determination of facility design requirements.

e. The gross system effectiveness parameters defined in block 4 will be further defined as additional design requirements are developed. These design requirements provide the inputs and the technical basis for preparing the initial System Specification (reference block 10).

f. At this point in the process, only the de-

scriptive entries, the "Design requirements" column, and the "Facility requirements" column of the RAS will be specified. Concurrently, time constraints, as appropriate, will be established, apportioned to functions, and specified in the "Design requirements" column. Detail instructions for completing RASs are contained in attachment 1.

Block 8. Identify and Perform Trade-Off Studies.

a. System/design engineering and cost effectiveness studies involving trade-offs were required in blocks 3 and 4 to determine the selection of alternative functions and to determine the requirements for design imposed by the selected functions. These design requirements were at the gross level providing recommended methods for accomplishing the gross- and first-level functions and converting these functions to requirements for design, such as purpose of the function, parameters of design, design constraints, and the requirements for reliability, safety, human performance, maintainability, etc.

b. With accomplishment of more system engineering by expansion of the first-level functional diagrams to a minimum of second-level functional diagrams and determination of the corresponding design requirements (blocks 6 and 7, respectively), additional trade studies are required concurrently with the development of flows and design requirements to provide the technical rationale for selecting certain flows and design requirements. Trade studies shall be performed by the GSE/TDC or SEG/R&T to support the above actions described in blocks 3, 4, 6, and 7. Requirements for trade studies for high-risk areas to be reported in the proposal and those to be performed by the contractors during phase IB will be identified in the RFP. These requirements shall include weighting factors for the significant factors to be used in the trade studies and key data; e.g., costs involving military operations and logistical support. As system engineering progresses, requirements for other trade studies may be identified by the contractor and the SPO. The performance of any additional trade-study effort requiring a change in funding of the phase IB contract will be subject to negotiation.

c. This action represents an early assessment of anticipated problems, focuses management attention on high cost, technical risk, and time constraining areas, and is directed toward predicting the consequences of significant alternative decisions. Since the resulting decisions become irrevocable at an early point in the program, it is essential that adequate management attention be directed to any suspect areas. Certain critical trade study areas will become apparent and will be identified for study. These trade studies are to be accomplished on a system basis by means of approach and standardized reporting to provide a means for systematically considering alternate decisions.

d. Trade studies are made at different levels; thus the detail reporting data required for different trade studies will vary considerably. Trade studies shall be reported describing the the analysis performed and the conclusions reached in selecting from alternative functions and design approaches. As design becomes increasingly detailed, the trade study reports become more definitive. Each trade study report shall cover the following topics: (1) identification and listing of functional and technical design requirements for trade-off; (2) identification of possible design approaches and their design characteristics; (3) comparison matrix of design approaches; and (4) selection of design approach. Detail reporting requirements are specified in attachment 1.

e. It may be that the selection still leaves two or three alternative design approaches. In this case, further detailed evaluation is pursued until the trade study process supports the existence of a "best fit" design approach considering all of the performance, technical feasibility, cost effectiveness, and delivery requirements. Parallel system engineering documentation shall be pursued for each alternative until such time as a firm decision is reached. A brief summary rationale for abandoning alternative design approaches shall be included in the study report.

f. The trade study report is used to generate and justify changes to schematic block diagrams, functional diagrams, and corresponding design requirements contained in the System Specification. As more engineering is done dur-

ing the definition and acquisition phases, the trade study results will affect Part I Detail Specifications. Trade studies of varying levels of complexity and impact will be accomplished during each phase of the system cycle. For example, trade studies range from conceptual level such as manned bombing system versus ballistic missiles, through selection of communication media, such as radio versus land line versus earth current transmission, through design of printed circuits such as soldered versus plug-in units, to trade studies concerning logistics, such as provisioning two items of MGE versus provisioning one item of MGE. Another example would be safety trade studies which include identifying hazards; safety problem areas due to equipment interfaces; safety requirements for conducting maintenance, test, and training during system operation. For electronic systems, computer programs become an important trade study consideration. For an example of a trade study report, reference attachment 2.

g. Trade studies may involve a variety of engineering techniques including complete or partial simulation of operations, environment, and maintenance loading. It may also include an application of probability theory; information theory; human, mental, sensory, and physical capabilities; servomechanism theory; mathematical models; and statistical models. These scientific tools provide the backup analytical data supporting the trade study. The practicability of applying all these tools must be considered. In considering the complexity of many trade studies, it is apparent that quick and reliable means of predicting the outcome for one design approach versus another is paramount. For example, the major factors in the choice of structural material for a space vehicle require a complex trade study. Utilizing the most current scientific tools available is required to provide quick and reliable means of prediction in consideration of (1) economics of the complete vehicle; (2) strength-to-weight ratio of the material; (3) experience of the plant technicians and the design team with particular materials; (4) manufacturing processes available for production and fabrication of

particular materials; (5) aerodynamic heating encountered; (6) physical characteristics of the material in contact with the propellants; and (7) available insulations and bonding techniques.

Block 9. Identify Subsystems and Major End Items, and Prepare Initial System Specification Tree.

a. This activity represents the culmination of efforts directed toward the definition and scoping of subsystems and the initial identification of major end items. The determination of major end items and their functioning relationships will be established by means of schematic block diagrams (hereafter referred to as schematic diagrams) described in detail in attachment 1. At this point in the program only general schematic diagrams can be prepared. As additional information is acquired, the schematic diagrams will become more definitive. The schematic diagrams will be used to establish and define the parameters of interface requirements between CEIs and within each CEI. The identification of subsystems and major end items allows determination of major portions of the system which can be assigned to one contractor or Government agency for design and development (reference exhibit I, AFSCM 375-1).

b. The initial specification tree, reflecting CEI installation in the system (reference figure 2, exhibit I, AFSCM 375-1) will be prepared to graphically portray the decisions regarding the determination of major CEIs and apportionment of engineering efforts. The specification tree represents a gross definition of the relationship between CEIs; i.e., the manner in which each CEI is to be assembled into the next higher level CEI. At this time, the specification tree is not expected to provide a complete identification of all CEIs constituting the hardware element of the system. As system design proceeds, the initial specification tree will be updated to reflect decisions regarding the selection or deletion of CEIs. The specification tree displays the magnitude of the hardware design effort in terms of prospective CEIs.

Block 10. Prepare Initial System Performance/Design Requirements General Specification.

a. The SPO prepares the initial System Specification which is to be included as part of the RFP. The GSE/TDC or SEG R&T shall prepare the technical portions of the initial System Specification. This System Specification presents total system requirements for the design and development effort based on system engineering experience previously acquired and reflects the major engineering decisions which have been made regarding the performance and design of the system.

b. The System Specification shall be based on the system engineering documentation prescribed herein; e.g., RASs and timeline sheets. Content requirements for the System Specification are specified in exhibit I, AFSCM 375-1. The following system engineering documentation shall be part of the System Specification: (1) Functional diagrams depicting the functional parameters of the total system (reference attachment 1). (2) schematic diagrams establishing the design performance parameters of each subsystem (reference, attachment 1). The SPO shall identify the system requirements to be controlled using system requirements ECPs (reference exhibit VIII, AFSCM 375-1) during the phase IB contract period.

c. Gross category I, category II, acceptance, test verification, and I&C requirements will be included in the System Specification to provide an estimate of the scope of the system test program. The test requirements are intended to provide the means of verifying that system performance and design requirements have been met. Results of the system test program conducted to meet the requirements contained in the System Specification will form the basis for the acceptance of the terms and conditions of design and development contracts.

Block 11. Provide Inputs to RFP. This step represents a culmination of all previous system engineering actions; i.e., the work statement included as part of the RFP will contain the cumulative results of engineering knowledge in terms of total system requirements. The significant engineering products to be included in the RFP are:

a. *System Specification.* As previously stated, the System Specification, including the specification tree and system engineering documentation will be included as part of the work statement.

b. *Trade Study Requirements.* Specific trade study requirements will be identified, as well as the approach to be taken in conducting these studies. The trade studies conducted by the GSE/TDC or SEG R&T will be included. Specific procedures and format requirements for trade studies will be specified as stated in attachment 1. The work statements will specify the trade studies to be made during the definition phase.

c. *Test Program Requirements.* This work statement input includes the category I, category II, acceptance, test verification, and I&C requirements contained in the System Specification and the test program requirements emanating therefrom. For example, "The flight test program shall consist of 10 flights, and flight X shall demonstrate that the requirements for stage separation have been met." Requirements for demonstration of reliability, maintainability, and other effectiveness factors as allocated to the various elements of the system shall be included. Any required safety demonstrations and explosive hazard classification testing will also be delineated.

d. *Activation Program Requirements.* The overall requirements for production, I&C, and training shall be included. These requirements will be based upon the System Specification, functional diagrams depicting the activation task, RASs, and time-line sheets. For example, the system engineering documentation relating to activation defines the tasks for installing and checking out the equipment. This would not include detailed I&C requirements that must be based on the detailed configuration information which will appear in Part II Detail Specifications but would include the gross requirements necessary for scoping the I&C tasks.

e. *Incentive Recommendations.* Incentive recommendations by the SPO deputy director of engineering will be based on the identification of high-risk technical, cost, and time areas. Incentives by definition are proportional to the risks involved. Where a high-risk area is in-

10 March 1966

AFSCM 375-5

involved, a proportionate incentive shall be established. Thus, the identification of high-risk areas serves as the basis for the development of incentive provisions.

Block 12. Contractors Start Proposal Preparation.

a. The next group of actions, blocks 12 through 18, depicts a *typical* sequence of actions by contractors in responding to an RFP. These actions are presented to illustrate the contractors' design iteration rather than to prescribe rigid procedures which must be followed by the contractors. It is intended to provide a better understanding of the requirements to be contained within the RFP, and the type and level of response expected in the phase IB proposals.

b. While the delivery of the RFP officially signals the start of the contractor proposal efforts, considerable effort will have been expended by contractors prior to this time: i.e., conceptual phase studies, advanced development efforts, and independent research and development efforts. Therefore, the program will not be starting from a zero point, but will usually have the benefit of considerable background information prior to the issuance of the RFP.

c. During the proposal preparation period, the GSE/TDC or SEG/R&T shall prepare the technical portion of the criteria to be used in evaluating the contractor response to the RFP.

Block 13. Review System Specification and System Engineering Documentation.

a. The System Specification and related system engineering documentation defined herein is the point of departure for contractor engineering actions during the proposal effort. An initial step by the contractor should be to review the System Specification to structure his engineering efforts in response to the RFP. Initial actions include (1) an evaluation of the requirements contained in the System Specification through the use of the background knowledge, experience, and capabilities possessed by the contractor; (2) the establishment of a proposed design approach to the requirements contained in the System Specification; and (3) the assignment of responsibilities to engineering ele-

ments within the contractor's organization for additional preliminary design effort.

b. The system engineering documentation becomes a major engineering management tool in assigning responsibilities to various engineering functions within the contractor's organization. Functional diagrams depict system requirements in functional terms; schematic diagrams depict design characteristics between and within each subsystem; RASs relate the functions to be performed by the system to the design requirement which must be satisfied to meet these functions; and trade study reports describe the comparative analysis and selection between alternative design approaches. As such, the documentation defines the engineering requirements to be satisfied and thereby provides engineering management with the tools necessary for assigning specific responsibilities to each engineering function and for assuring that complete system coverage is attained. Results of engineering efforts during the proposal period should be subsequently reflected in the System Specification and the system engineering documentation submitted as a part of the contractor's proposal, thereby providing a common base for SPO evaluation of contractors' technical proposals.

Block 14. Verify and Expand Functional Diagrams and Design Requirements.

a. Following the review of the RFP data, particularly the work statement, and the System Specification included therein, the contractor should conduct a critical review of the top, first-level, second-level, etc., functional diagrams contained in the RFP. The contractor should verify the accuracy and adequacy of the operations, maintenance, test, and activation functions appearing in the functional diagrams. If necessary, the functions and their flows should be modified to reflect the contractor's technical experience and planned approach to meeting the system requirements. The flows should be expanded to lower levels as necessary to adequately portray his approach to system design. Where alternative modes of operation are applicable, these modes should be represented by alternative flows. The verified and

expanded functional diagrams should be made part of the contractor's technical proposal.

b. Concurrently with the review of the functional diagrams, the contractor should critically review the design requirements contained on the RAS. The contractor should verify the accuracy and adequacy of the requirements for operation, maintenance, test, and activation functions. Where necessary, the requirements should be modified or expanded to reflect the contractor's technical experience and approach. The verified and expanded design requirements should be used to evaluate whether the functions identified and their implied hardware solutions will meet the conditions specified in the System Specification.

c. Time-line analyses should be performed on time-critical functions to determine automatic or manual requirements. Functions should be considered time-critical when the estimated time required to perform the functions has an adverse effect on reaction time, downtime, and/or availability requirements. Time-line analysis should be used to derive time constraints applicable to design requirements identified in the RAS and should provide the basis for evaluating time-sensitive elements defined by the operational concept and plans in the RFP. The time-line data should depict the concurrency, overlap, and sequential relationships of the functions involved in the analysis and evaluation effort. Time-line sheets should be prepared in accordance with attachment 1. The facility requirements contained in the RAS should be reviewed and expanded to reflect the contractor's requirement for facility support, paying particular attention to the development of those requirements that are of a direct technical support nature. Where possible, specific facility performance or design parameters should be listed against the system functions on the RAS.

d. The verified and expanded design requirements on the RAS and time-line sheets should be made part of the contractor's technical proposal.

Block 15. Identify Requirements for End Items, Facilities, and Personnel.

a. Utilizing the design requirements contained on the RASs for operations, test, activa-

tion, and maintenance functions, the contractor should extract portions of one or more RASs and reassemble the design requirements into CEIs by means of schematic diagrams. The contractor should utilize the information provided by schematic diagrams in the System Specification to accomplish the transition from a functional orientation to an equipment orientation. The schematic diagrams provided in the System Specification should be verified and expanded as appropriate. The primary objective of preparing schematic diagrams is to graphically portray interfaces of components and to provide a tool for integrating design requirements into specific equipment and facility design recommendations.

b. A significant action during the preparation of the contractor's proposal should be to identify preliminary design requirements for the major CEIs contained in the specification tree described in block 9. These CEIs will have been identified by the SPO in the initial System Specification. The design requirements should be entered on a design sheet as described in attachment 1. It is not expected that complete design requirements for these major CEIs can be provided in the proposal; however, they should be detailed enough to allow proper evaluation of the intended design approach for the CEI. Requirements which may be satisfied by items of unmodified equipment in DOD inventory (including facilities) or commercially available items should be identified. The contractor should consider (1) equipment defined by current Government specifications or modifications of such equipment; (2) off-the-shelf commercial equipment currently in DOD inventory; and (3) other off-the-shelf commercial equipment or modifications of such equipment. Furthermore, there may have been DOD equipment specified in the SOR/OSR/ADO or PTDP such as a 7040 computer or a Titan II booster.

c. In the process of review and expansion of facility requirements on the RAS, certain facility end items may be tentatively defined, particularly in the case of command and control centers, radar tracking stations, etc. It is necessary to recognize as early as possible that certain facility equipments may impose critical re-

quirements on other facilities. For example, launch spray or deluge facility subsystem requirements may impose critical requirements on water and power subsystems. In the case of contractor identification of a major operational CEI, such as a commercial computer, it may be possible to define detailed facility interface requirements such as power, environment, and floor space. Where this level of detail is indicated by the CEI definition, the facility requirements should be recorded on a facility interface sheet as outlined in attachment 1. Based on these facilities, CEI design requirements, and data provided in the RFP, the contractor shall prepare facility perspectives and schematic diagrams. For examples of facility schematic diagrams and facility perspectives, reference attachment 2.

d. Utilizing (1) personnel and training constraints contained in the System Specification, (2) system design requirements, and (3) preliminary methods of accomplishing gross functions (block 4), the contractor should identify the consequent personnel duties on a gross level, identify personnel positions, and provide an estimate of the number of personnel who will be required to operate, maintain, and control the system.

Block 16. Perform Selected Trade-Off Studies and Identify Definition Trade-Off Requirements.

a. Blocks 14 through 16 are accomplished on a concurrent basis; that is, trade studies are required to provide the technical basis for the actions described by blocks 14 and 15. For example, determining time estimates for time-critical functions will often require comparing one potential solution with another by means of a trade study. It is not intended that all the trade studies specified in the RFP be actually made during the proposal preparation period. Trade studies requiring extensive effort will be made during the definition phase.

b. The contractor should review the Trade Study Reports provided with the RFP and the trade study requirements identified for accomplishment in phase 1B and verify their accuracy, need, and criticality. The contractor should identify, as part of his proposal, any additional critical trade studies required during the defini-

tion phase. The contractor should document, in accordance with attachment 1, the trade studies required to be reported in his technical proposal.

Block 17. Verify and Expand System Specification.

a. The System Specification contained in the RFP presents in standardized format the system design approach to be employed in meeting system requirements. In verifying and expanding the System Specification, the contractor will be required to present engineering decisions which convey an understanding of the requirements, an overall engineering capability, and management acumen.

b. In the System Specification, the contractor should (1) reflect decisions regarding various trade studies performed; (2) expand the specification tree to reflect lower level CEIs, showing the assembly relationship involved in the production and I&C process; (3) present an approach to the test program, including demonstration of effectiveness factors, such as reliability/maintainability and any required safety demonstration, as reflected by the requirements contained in section 4 of the System Specification; (4) present an understanding of the interface requirements of the system (i.e., the relationships between and within subsystems); (5) show his understanding of the dependence the system has on inputs from and outputs to other systems; (6) depict the relationships between facilities, equipment, procedural data, and personnel elements of the system (i.e., which functions have been allocated to each of the above elements and what is the impact on AF manpower, equipment costs, schedules, facility construction, etc.); (7) present the items of inventory or commercial equipment he plans to use as part of the system; (8) confirm the quantitative requirements initially specified by the SPO; and (9) present his approach to the operation and maintenance of the system.

c. It is the intent of the System Specification provided in the RFP to establish a frame of reference for further engineering effort rather than an absolute set of requirements. The specific intent is to allow for maximum flexibility of design approaches to satisfy total system requirements. It is at this point that creative

effort is required and has the largest payoff. The System Specification provides a standard base within which competition can freely operate to ultimately produce the best system at the lowest possible cost in the shortest time period. In verifying and expanding the System Specification, each contractor has maximum flexibility to display his full capabilities within the parameters of system requirements.

d. In the case of an associate contractor structure, each associate will respond to the appropriate subsystems for which he is responsible as well as the general requirements contained in other sections of the System Specification. It will be the task of the Source Selection Board to evaluate the proposals in terms of the best possible combination of contractors with full consideration of interface approaches assumed by each associate contractor.

Block 18. Provide Inputs to Contractors' Proposals. The contractors' engineering approach to the requirements contained in the RFP should be reflected by specific inputs to the proposals. In addition to these engineering inputs, technical inputs should be made to the program management plans such as the Test Plan, the Logistical Support Plan, and the Activation Plan. The system engineering documentation developed during the proposal preparation period should be an integral part of the proposal. Since the proposal submitted in response to the RFP will be subsequently used as the basis for contract negotiations, it is essential that well-defined engineering requirements be established by means of the proposal.

3.2 Phase IB:

Block 19. Engineering Inputs to Phase IB Contract. Contract award for definition signals the start of a significant engineering effort to define the total requirements of the system. The contract will be awarded against the System Specification identified as part of the program requirements baseline. While preceding blocks have described in some detail the preliminary engineering definition effort primarily accomplished by the SPO, it is during phase IB of the program that engineering definition in depth is performed by the contractor. The engineering products of the definition effort

will define the design requirements baseline which scope the total engineering effort for the acquisition phase. It is therefore essential that maximum engineering effort be expended during phase IB to define all the elements of the system in as complete detail as possible. To accomplish the latter, an orderly sequence of steps has been established to assure that a systematic approach is followed. The following steps provide the means for documenting the engineering definition of each element of the system.

Block 20. Identify Applicable Requirements and Update Source Documentation. The contractor shall identify the requirements and corresponding source documentation applicable to the system under consideration. Information sources include the source documentation list provided by the SPO (reference block 2), the negotiated work statement and System Specification, and other background information applicable to the system. The product of this effort shall be a single source documentation list to be used as source reference for the system program. As the documentation contained in the list is updated, the list shall be updated to reflect the current issue dates of the referenced documentation. The intent is to provide a method for identifying in a single place an authoritative reference list of documentation that represents available knowledge of the system program.

Block 21. Develop Detailed Operations Functions.

a. The contractor shall develop detailed operations functional diagrams which depict graphically and sequentially the detailed functions which must be satisfied to meet stated system requirements. These functional diagrams (reference attachment 1) are indentures to the functional diagrams that were presented in the phase IA RFP, expanded by the contractor's proposal, and included in the negotiated System Specification for phase IB.

b. The contractor is not limited to the number of functional diagrams required to indenture each major function. To describe the basic operations requirements of the system in functional terms, it is anticipated that third- or possibly fourth-level functional diagrams will be required. In actual practice, the level of inden-

ture of functional diagrams can be based only on sound engineering judgment and the peculiarities of the system under consideration.

c. From a logical point of view, it is necessary to define operations functions prior to defining maintenance, test, and activation functions. However, it is also true that the development and selection of operations functions can be influenced by previously acquired experience concerning maintenance, test, and activation implications. Operations functions which cannot be logically supported from a maintenance, test, or activation point of view are not to be selected. While the identification of detailed maintenance, test, and activation functions is based upon operations functions solutions, there are other constraints and considerations which limit the selection of these solutions. Subsequent efforts to define the maintenance, test, and activation functions will affect the selected operations functions and will validate or result in changes to previously selected operations functions. The prime emphasis in developing operations functional diagrams should be to determine the minimum essential functions necessary to meet operations requirements.

d. Alternative functional paths for meeting system operations requirements shall be considered. Though trade studies were identified and made earlier, the major portion of system trade studies will be conducted during this phase of the program. It is essential, therefore, to select only those alternatives which offer significant payoffs in terms of time, cost, and performance, and to investigate these alternatives in depth. Engineering decisions shall be made on the basis of the best approach to the system rather than upon any feasible approach. The functional frame of reference specified and depicted by the basic functional diagrams (top-, first-, and second-level) should be stabilized by this time.

e. Since future definition effort will be directed toward deriving solutions to operations functions, major engineering effort shall be expended in preparing functional diagrams to insure completeness and accuracy. Functional diagrams represent the apex of the definition pyramid and establish the total frame-of-reference for the definition of the equipment, facili-

ties, personnel, and procedural data required to meet system objectives. Subsequent indentures cannot be satisfactory if the frame-of-reference is in error. The significance of the initial detailed functional diagrams cannot be overemphasized. They establish the ultimate goals which must be met by the total engineering process.

Block 22. Develop Design Requirements for Operations Functions.

a. This action is an extension of the work prescribed in blocks 4, 7, and 14 and changes made during the contract negotiation. Up until this time, the operations, maintenance, test, and activation functions have been looked at concurrently. The operations functions are now studied in detail. This is not to convey that the impact of maintenance, test, and activation functions is not considered, but to emphasize that, before detail definition for maintenance, test, and activation can be vigorously pursued, engineering must have defined what is to be produced and what is to be maintained, tested, installed, and checked out.

b. Inherent in describing any process is the necessity for specifying required actions in series. This does not imply that the system engineering process simply follows from left to right from block to block without considerable concurrency and feedback of results to change original ideas. These feedbacks are represented by the dotted line from the first group of blocks on the operations design line to the first group of blocks on the maintenance design line.

c. The operations functions shall be translated into design requirements and documented on the RAS. In developing the functional diagrams portraying the operations functions, the contractor must determine design requirements to assess the validity of the function chosen and to provide the basis for future equipment selection configuration. In translation of the operations functions into design requirements, major emphasis shall be placed on quantification of information in performance terms.

d. The RAS shall contain the applicable functional diagram number, the name and number of the function, the design requirements, the facility requirements, and CEI identifica-

tion. The "Design requirements" column shall contain (1) substantiation of the function; (2) parameters of design (i.e., input-output performance values and allowable tolerances); (3) quantitative requirements which constrain design such as power, physical, interface, environment, human performance capabilities and limitations, and time; and (4) requirements for reliability, survivability/vulnerability, safety, maintainability, and transportability. For an example of a RAS completed to this point in the process, reference paragraph 6.0, attachment 2.

e. The "Facility requirements" column shall identify and justify facility functions such as (1) environmental requirements (e.g., temperature and humidity ranges, illumination, and noise levels); (2) power, air conditioning, ventilation, heating, space, and mounting provisions; (3) civil/structural/architectural requirements imposed by the function and design requirements (structural requirements shall be in terms of material and minimum dimensions); and (4) facility equipment identified earlier. The facility requirements, the design requirements, and the top level functional diagram provide the data for facility system engineering (FSE) to identify critical requirements and to complete facility functional diagrams, RASs, schematic diagrams, facility perspectives, and design sheets as appropriate for the TSRP. FSE contractors shall identify those operations, maintenance, test, and activation functions with facility implications and prepare facility functional diagrams. The facility design requirements resulting from the facility functional diagrams shall be documented on RAS. In this case the "Facility requirements" column of the RAS shall be used to identify additional facility requirements imposed by facility design requirements.

f. Time-line analyses shall be performed on the time-critical operational functions which may or may not involve human performance. The design requirements shall be used to determine if the times imposed by the functions on the RAS, when cumulated, will meet the critical time requirements specified in the System Specification. Time-line sheets shall be used to record the time-line analyses as specified

in attachment 1. An example of a time-line sheet of time-critical operations functions is shown in paragraph 9.0 attachment 2. The time lines shall display the length of time required to accomplish a function plus the appropriate function start time considering optimum use of equipment and personnel. Travel time and equipment warmup time are to be included in the time calculations. The time lines determined in block 14 were estimated allowable times, whereas the times calculated or predicted at this point are estimated required times based upon the design requirements developed. The time-line data shall be used to evaluate the operational concept and plans in terms of system reaction time.

Block 23. System Requirements Review.

a. This action consists of the initial SPO review and evaluation of the contractor's effort to define the system requirements in terms of operations functional diagrams, RASs, and time-line sheets. Backup trade studies should be available to support the contractor's technical decisions presented for review. Since this documentation establishes the frame of reference for the remaining system definition effort, the SPO will verify that the frame of reference is valid and that interfaces between contractors have been appropriately allocated. In order to accomplish this validation, it is necessary to assure that all participating contractors have provided their functional diagrams to the appropriate integrating or prime contractor prior to the initial system requirements review. All contractors shall participate in the initial system requirements review.

b. The function of the "in process" review will be to evaluate the progress and direction of the initial phase IB effort rather than to conduct an on-the-spot technical integration of the system. This review serves to inform the SPO that the contractors are performing within the scope of the definition contract and are conducting an effort appropriate to the tasks delineated by their work statements. This action establishes a documented point of departure for future effort. While the degree of formalization and the depth of this review is dependent upon the nature of the program, the review will be the basis for any technical or management re-

alignment considered necessary by the SPO to meet the definition phase objectives. As a minimum, it is expected that the functional diagrams to the third level would be reviewed at this time.

c. This system requirements review will serve as the vehicle for additional direction: e.g., any changes in requirements would be reviewed for impact on established functions and the corresponding design approach. It is to establish an orderly procedure for the exchange of technical information using standardized documentation, between the contractors and the SPO at a specified and scheduled time. This action must assure that engineering decisions are recorded, that actions are assigned to participating agencies, and that technical direction is understood by all concerned activities.

Block 24. Perform Trade-Off Studies (Operations Elements of the Systems).

a. Blocks 24, 25, 26, and 27 are performed concurrently. The contractor shall accomplish (1) the trade studies specifically directed in the definition phase contract and (2) those necessary to provide technical substantiation of requirements for CEIs, facilities, personnel, and training required for operations functions. Where possible, efforts to perform the directed trade studies shall be correlated with the trade study actions required in support of blocks 25, 26, and 27. Trade study efforts shall balance the relationship between categories I and II test requirements, operations design requirements, and activation requirements. The decisions made and documented to date are an input to the trade studies to be performed. The trade studies shall identify alternate CEIs, facilities, personnel, programs for training, and for electronic systems the planned use of computer programs required to satisfy the operations functions and design requirements developed in blocks 21 and 22.

b. The trade studies shall consider as a minimum (1) availability of current equipment in the DOD inventory, existing facilities, facility equipment, personnel with necessary skills, and existing training programs and training equipment; (2) special tooling required; (3) development and production lead times required; (4) state-of-the-art; (5) manufacturing require-

ments; and transportation requirements. Special emphasis shall be directed to assessing the impact on the total system made by the selection of alternate CEIs, facilities, personnel, and training. For example, the effect a spacecraft configuration has upon thrust requirements, payload, size and weight of personnel, and OGE. An example of trade study factors influencing development, costs, and facility requirements in the selection of a propulsion design are (1) damaging noise and vibration levels; (2) engine radioactivity or potential for spreading radioactive material after catastrophic malfunction; (3) propellant toxicity characteristics; and (4) high residual radioactivity after operation.

c. Trade studies shall be documented in accordance with attachment 1, and reported as directed by the SPO. The decisions made from the results of the trade studies shall be reflected on (1) design sheets, inventory equipment requirements and CEI identification specifications, schematic diagrams for operations CEIs; (2) design sheets, inventory equipment requirements specifications, facility perspective, schematic diagrams, and facility interface sheets for facilities; and (3) RASs and time-line sheets for operations personnel and training. Trade study results shall be examined to determine feedback changes to operations functions, design requirements for the operations functions (blocks 21 and 22), and to the System Specification.

Block 25. Develop Design Requirements for Operations End Items.

a. Utilizing the design requirements on the RAS, the contractor shall extract portions of one or more RASs, reassemble the design requirements into operations items by means of schematic diagrams, and develop corresponding gross category I test and gross activation requirements. The design requirements on the RAS, and the initial test requirements shall be integrated on the design sheet for each CEI and critical components. Hereafter, CEI refers to contract end items or critical components. The operations items identified at this point are typically the highest level assemblies expected from the factory. For manned or unmanned space systems, manned or unmanned aircraft systems,

and ballistic missile systems. AVE and OGE comprise the operations CEIs for which design requirements are developed. For electronic systems, OGE (including computers), and computer programs, are the operations CEIs for which design requirements are developed. See figure 3 in chapter 5 for an illustration of the system element breakdown of typical system programs.

b. The design sheet shall be used as the basic design and test requirements document, serving as the "design to" forcing function upon engineering and providing initial category I test requirements. The design sheets prepared during phase IB become sections 3 and 4 of the Part I Detail Specifications which are required products of phase IB. It is mandatory that requirements be stated in engineering terms. Specific numerical input-output performance values and allowable tolerances shall be used rather than general statements. For example, statements such as "the CEI shall be designed to be maintainable" is not acceptable. Rather, the requirements imposed by maintainability shall be stated in quantified or best-estimate quantified or well-qualified terms which define specific design features (see MIL-M-26512C).

c. The basic intent of the design sheet is to provide a single focal point for consideration of all design and categories I and II test requirements for a CEI. Design and test requirements shall reflect inputs from various disciplines such as design engineering, facility engineering, safety engineering, human engineering, maintainability, survivability/vulnerability, reliability, transportability, value engineering, and test and shall be based on design and test requirements in the System Specification, RAS, trade study, and any other system requirements documentation (reference block 20). Entries will vary considerably depending upon the complexity of the CEI, the preliminary design engineering accomplished during the definition phase, and system requirements. During preliminary design engineering and in the process of trade studies, design solutions to design requirements develop. The design solutions selected by the contractor now become recommended design approaches.

d. The design and test requirements for each

CEI shall be documented on the design sheets. Common hand tools, desks, furniture, etc., shall not be identified by means of design sheets. The design sheet shall be identified by the CEI number or for engineering critical components the identification number assigned to the item (reference paragraph 6.2.3, exhibit X, AFSCM 375-1), and shall appear the first time the sheet is prepared. The CEI numbers and nomenclature of the design sheet shall be entered on the RAS under the "Equipment Identification" column adjacent to the corresponding design requirements which the item of equipment satisfies. For items not to be identified on a design sheet the nomenclature and index number (reference attachment 1) shall be entered. The design sheet shall be reserved for contractor furnished equipment. Detail requirements for preparation of the design sheet are specified in attachment 1.

e. Design requirements to be satisfied by DOD standard items of equipment and facilities shall be directly translated from schematic diagrams and RASs into the requirement sections of the appendixes of the Inventory Equipment Requirement Specifications (reference exhibit V, AFSCM 375-1). The contractor shall use the AF technical information file (MIL Handbook 300) and any other means available to insure maximum considerations of (1) equipment defined by current Government specifications or modifications of such equipment; (2) off-the-shelf equipment currently in DOD inventory; and (3) other off-the-shelf equipment or modifications of such equipment. The inventory equipment requirements shall be quantitative and include the functional characteristics of the item in the system, subsystem, installed environment, and complete item identification (i.e., Federal stock number, part number, nomenclature). The functional characteristics and design requirements are to be derived from the systems specification, RAS, trade studies, and other system requirements. The Inventory Equipment Requirements Specification is used directly in lieu of the design sheet whenever the contractor intends to recommend existing unmodified DOD inventory equipment to fulfill the functional characteristics and design requirements. The design sheet is used for inven-

tory equipment and commercial items which are to be substantially modified. The Part II Detail Specification format for prime equipment (reference exhibit II, AFSCM 375-1) is applicable for defining unmodified or slightly modified commercial equipment. The nomenclature part number and/or Federal stock number of the inventory equipment item shall be entered on the RAS in the "Equipment Identification" column and adjacent to the corresponding design requirement which the item of equipment satisfies.

f. Schematic diagrams are used to reassemble the design requirements on the RASs into an integrated set of design requirements comprising a CEI. In the development and use of schematic diagrams and the preceding functional mechanization drawings, trade studies may be required. Schematic diagrams shall depict the functional operation of the recommended equipment in a system installed configuration. Later these schematic diagrams shall be revised to include maintenance characteristics determined from the RASs developed in analyzing maintenance functions. The schematic diagrams shall show how the design requirements on the RAS are to be satisfied by the proposed CEI or subsystem designs. They shall show the flow of signals and sequencing requirements, together with interface requirements with other subsystems and CEIs. Schematic diagrams shall identify the RAS and functions being satisfied. They shall illustrate end-to-end and/or closed-loop functional relationships of the hardware to satisfy design requirements for the operational mode and shall later be revised to include the maintenance mode. The evolution of schematic diagrams starts with functional diagrams and leads to functional mechanization diagrams, which lead to functional schematic diagrams and detail schematic diagrams. The terminology of these diagrams is not standard. Functional mechanization diagrams may be referred to as logic diagrams. However, there are other types of logic diagrams which are used subsequently to schematic diagrams, as in the case of electronic circuitry used to prepare detail drawings. Mechanization, schematic, and logic diagrams are required at different levels, just as "design" occurs at different levels. Detail re-

quirement for schematic diagrams are in attachment 1. An example of schematic diagrams is presented in paragraph 8.0, attachment 2. Detail requirements for logic diagrams are presented in MIL-STD-806.

g. CEI test requirements developed at this point shall be limited to the initial definition of category I tests necessary to demonstrate compliance with the performance and design requirements specified in section 3 of the design sheet. For the purpose of this manual, category I tests are defined as including system, subsystem, and CEI engineering evaluation tests:^{*} preliminary qualification tests^{*}; formal qualification tests; tests and demonstrations of effectiveness factors; and engineering critical components qualification tests necessary as part of the design and development program. Acceptance tests for CEIs, subsystems, and systems are not part of category I tests. Test requirement entries in section 4 of the design sheet shall refer to the section 3 requirement to be demonstrated and shall indicate whether compliance will be demonstrated by engineering evaluation tests, preliminary qualification tests, formal qualification tests, tests and demonstrations of effectiveness factors, engineering critical component qualification tests, or combinations thereof. (Reference AFR 50-14, AFSCM 375-4, and exhibit II of AFSCM 375-1 for category I test objectives.) Where selected section 3 requirements compliance demonstration must be deferred to category II testing due to (1) the integral system relationship of certain CEIs or (2) the need to make such tests in an operational environment, these category II test requirements shall be specifically identified on the design sheet. All category I and category II test requirements shall be identified in section 4, "Quality assurance," in the System Specification and Part I Detail Specifications.

h. Test requirements developed shall be in consonance with the test concepts and requirements established by the program requirements baseline. Test requirements for category I tests should not duplicate each other and should not duplicate the acceptance, I&C, and category II

^{*}NOTE: Limited to tests meeting the criteria in exhibit II, AFSCM 375-1.

test requirements. To minimize test duplication, reliability tests and demonstrations shall be performed as an integral part of other category I tests and category II tests to the greatest extent possible. Effort shall be made to provide test program continuity from a test "measurement-to-be-accomplished" and a time-sequence basis. For example, engineering evaluation and qualification tests may quantitatively verify that a specific pull force will open a critical module drawer under all operations conditions expected to be experienced by the item: acceptance tests would more simply measure the force required to open the module drawer at ambient conditions on the specific item being accepted to determine whether manufacturing tolerances are such that the pull force was within the allowable maximum/minimum ranges specified in the contractual specification; category II tests would not measure the required force at all, but may determine whether the required pull force was within the capability of the personnel simulating the operations situation.

i. CEI, subsystem, and system category I testing shall be done before acceptance of the initial CEI, subsystem, and system. In some instances, acceptance testing may be conducted on a deviation basis. For example, when CEI qualification testing has not been completed before acceptance of the initial CEI, a contractual deviation must be granted before initiation of the CEI acceptance tests.

j. Based on the test requirements for operations CEIs, the test functional diagrams and corresponding RASs, schematics, and test equipment design sheets shall be further expanded or initiated to define new test functions, test sequences, and requirements for special test equipment, test facilities, and test personnel. As the definition phase progresses, test and activation functions and related equipment, facility personnel, and procedural data requirements that are generally defined at this point shall be expanded into test and activation requirements in the same manner as operations and maintenance requirements. Test and activation requirements and solutions shall be subject to the reviews and controls specified for operations and maintenance.

Block 26. Develop Operations Requirements for Facilities.

a. Facility system engineering (FSE) shall integrate facility design requirements into facility CEIs in the same manner as for other operations CEIs (reference block 25). Facility CEIs may be represented by complete facilities such as ADC control centers, SAC launch control facilities, and TAC alert hangars which also serve as facilities for maintenance, or by critical RPIE subsystems such as power generation and distribution and environmental control systems. In some cases facility CEIs may indenture to other CEIs. Facilities that must be constructed for system operation or in support of system operation shall be defined in Facility CEI Specifications (reference exhibit III, AFSCM 375-1). Equipment so identified shall be defined on design sheets, and the determination of RPIE/AGE designation will be made by the Air Force in accordance with AFR 400-41 prior to initiation of the acquisition phase. Facilities or equipment available in Government inventory shall be defined in the Inventory Equipment Requirement Specification (exhibit V, AFSCM 375-1).

b. The essential inputs to the facility CEI Specifications and equipment design sheets shall come from (1) functional diagrams; (2) schematic diagrams; (3) RASs; (4) facility interface sheets; and (5) engineering analysis, evaluation, studies, and site investigations.

c. The facility functions identified by other contractors shall be analyzed by the FSE and further developed into specific facility functions depicted on functional diagrams. This analysis will normally result in the development of lower indenture functional diagrams and preparation of RAS by the FSE to further define the facility requirements and concepts of design.

d. Facility interface sheets prepared by other contractors shall be analyzed by the FSE and collated into design requirements for specific facility CEIs. When being prepared by contractors other than the FSE, the facility interface sheet is a work sheet and a checklist to assist the contractor in developing the facility support requirements for operations equipment. In this manner, each of the participating con-

tractors states his requirements for facilities support of the operations CEI he is defining. The facility interface sheet is the means for transmittal of requirements data to FSE. In the hands of FSE, the facility interface sheet becomes a working tool for the FSE to collect and collate all interface requirements imposed on a particular type of facility subsystem. For example, all facility interface sheets showing CEI requirements for electric power are collated, along with RAS requirements, to provide input to the preparation of the power subsystem schematic block diagram and design sheet. The same facility interface sheets may be sorted by specific locations or areas to derive the structural and environmental requirements for a particular building.

e. The FSE shall originate facility interface sheets where the definition of a particular operations facility CEI results in an interface with another facility CEI: e.g., launch duct requirement for cooling water. They will be handled and processed by the FSE just like any other facility interface sheet. The extent of entries on the facility interface sheet will depend on the extent of definition of facility CEIs and operations CEIs in block 25. Paragraph 7.0, attachment 1, specifies the detail requirements for completing the facility interface sheet. In conjunction with the preliminary design of facilities using schematic diagrams, it will be necessary to make site surveys to confirm the preliminary site surveys made earlier to acquire civil engineering data not otherwise available. The site surveys shall take into consideration topography, aerology/meteorology, and geological and geographic areas. The task of assessing site capabilities with respect to remoteness, industrial, or support considerations shall be defined by the SPO for the FSE conducting the surveys. Incident to site surveys, the investigation of subsurfaces and the analysis of water supplies shall be conducted and reported as prescribed by the SPO.

f. Inventory Equipment Requirement Specifications shall be used only for existing Government facilities and minor modifications thereof. Basic technical requirements to be entered directly in the Inventory Equipment Specification shall be to a level of depth that will allow

technical evaluation of the need for and extent of facility change required. Design characteristics shall not restate available information, but shall reference the identifying number, location, and real property records describing the existing facility.

g. Facility schematic diagrams shall be prepared and used in trade studies and in preparing design sheets. The diagrams shall present the subsystem components in the same logical and sequential manner depicted on the facility functional diagrams. Specific points of interface shall be indicated to depict the subsystem in a total system installed mode. More than one schematic diagram may be developed to indicate alternate methods of satisfying functional requirements. When this is done, the diagram shall be identified and classified in reference to the assigned subsystem.

h. The requirements derived from all sources and analyses are arranged by the FSE into a basic facility concept. Attention shall be given to grouping design requirements on schematic diagrams and design sheets so that the integrity of TSRP, NSRP, and critical RPIE subsystems is established and maintained while recognizing the requirements and procurement policies of the military construction program (MCP). Test and activation considerations must be developed in the test and activation system engineering documentation for facility CEIs, as well as requirements for particular facilities imposed by system or other CEI test and activation functions.

i. The integrated civil/structural/architectural operations design requirements for facilities shall be supported by facility perspectives depicting the area plan, site, elevation, and floor plan. An area plan should show location of the facility with respect to general area. A detailed site plan should include access requirements, special widths, required relationships between outside elements, clearances, parking, loading required setbacks, paving, etc. A floor plan should include dimensional requirements, height requirements (cross section), doors, widths of entrances, location of special electrical or mechanical provisions, clear space requirements and blockouts, elevations, anchor bolts,

or other provisions for equipment identified to be housed in the facility.

Block 27. Develop Requirements for Operations Personnel and Training.

a. With equipment, computer programs, and facilities defined in terms of integrated design requirements on design sheets and the Inventory Equipment Requirements Specifications, the RASs shall now have additional entries made to identify personnel, training, training equipment, and procedural data requirements imposed by the equipment and facilities defined.

b. When function and design requirements on the RAS demand man-equipment interface (human performance to operate operations equipment or facilities): personnel, training, training equipment, and procedural data requirements shall be entered on the RAS. In determination of these requirements, inputs shall be made from engineering, safety specialists, personnel subsystem specialists, and technical publication personnel. The data developed at this point, plus the data to be produced later, shall be used as the source data for determining the (1) extent of training required; (2) preliminary list of training equipment; (3) list of required procedural data; and (4) qualitative and quantitative personnel requirements information (QQPRI). The SPO may require the contractor to prepare selective task analyses to provide more detailed data for determining detail design of man-equipment interfaces; determining the training required; determining programed instruction requirements; selecting and designing training equipment and aids; and preparing the QQPRI. These detailed data shall be based on the criteria contained in the RAS required by contract and shall be developed in accordance with MIL-D-26289 for personnel information.

c. The "Personnel and training equipment requirements" column shall have entries defining (1) the major tasks required to be performed by personnel; (2) the time required to accomplish the tasks; (3) the significant human performance requirements determined by or constraining the tasks, including sustenance and life support requirements; (4) the extent of training required; and (5) training equipment or aids, including the class of training

equipment or aids. The personnel, training, and training equipment required is based on the cumulative effect of the line entries in the "Personnel and training equipment" column of the RAS. Just as the design requirements are to be grouped into CEIs, the tasks are grouped into Air Force specialty codes (AFSC), the training requirements are grouped into courses, the class of training equipment recommended is synthesized into training equipment on design sheets, and the procedures are grouped into procedural data. Where the procedure for operation of equipment and facilities is not obvious, and procedural data are required, the type of procedural data and identifying number shall be entered under the "Procedural data requirements" column. Detailed requirements for completing these columns are specified in attachment 1.

d. The information developed in the "Time required" column serves as an input to and verification of the estimated required times developed for time-critical operations functions in block 22. Time-line sheets shall be used in performing trade studies between the least time required to perform a given function and the best use of personnel and equipment accomplishing the function. Results of these trade studies may lead to a change from the manual operation to automation or mechanization; i.e., in the case where the time for man to calibrate an electronic CEI will not meet reaction time.

e. Based upon the above personnel requirement and task information, category II personnel subsystem test and evaluation concepts and requirements can begin to be formulated to provide inputs to the appropriate test plans.

Block 28. Select AVE and/or OGE and Facilities.

a. This action represents the contractor's identification of equipment, facilities, and computer programs essential to the performance of the intended mission. These equipments, facilities, and computer programs (reference paragraph 19b, chapter 6) shall be defined by means of design sheets or Inventory Equipment Requirements Specifications in terms of design requirements necessary to meet established system functions. This selection of equipment

includes only the equipment which performs the operations mission: e.g., booster, spacecraft, command and control console, and radome. Subsequent selections (reference block 41) will include equipment and facilities required to maintain equipment selected for the operations mission.

b. Engineering management emphasis is required to assure that the selection of equipment and facilities is valid and based on sound engineering judgment and supporting documentation. By tracing the logic of the process from system requirements to functions to design requirements, the engineering manager can substantiate the validity of the equipment selected and, if required, direct additional engineering definition effort. This step represents a major decision point and management must be assured that a thorough job is accomplished. Subsequent effort may require changes in the selection of AVE and/or OGE and facilities; however, maximum management effort should be directed to keep these changes at a minimum. The equipment and facilities selected shall be identified on the specification tree in the System Specification.

Block 29. Identify High Risk Areas and Long Lead Time Items.

a. The contractor shall identify high-risk areas and long-lead-time CEIs which are either time, cost, or performance critical. These high-risk areas and long-lead-time items include items which are state-of-the-art problems, critical materials, engineering critical components, significant dollar cost items, and items which require extensive manufacture or testing time.

b. The purpose of this identification is to direct specific emphasis where required to assure that unforeseen delays, costs, and schedule slippages are not built into the program. While the conceptual and early definition phase efforts will have identified some of the problems to be anticipated in high-risk areas, this action is to assure that these problems are studied and resolved. For example, schedule adjustments, selection of alternative design approaches or early procurement actions may be required.

Block 30. System Requirements Review.

a. The SPO will review the selected AVE and/or OGE and facilities: the personnel requirements; the effectiveness factors apportionment, and high-risk areas for the purpose of assuring that system requirements are being met. The system engineering documentation (e.g., functional diagrams, RASs, schematic diagrams, design sheets, inventory equipment requirement and CEI Identification Specifications, facility interface sheets, trade-study reports, time-line sheets, and facility perspectives, leading to the selection of equipment and facilities) will be selectively reviewed for technical adequacy. Selection of documentation to be reviewed and the depth of review will be established by the SPO. Specific attention will be directed toward a review of interface documentation between related contractors to assure that system compatibility is being maintained. The schematic diagrams will furnish the basic information necessary for the review and evaluation of interface problems and solutions.

b. Actions emanating from contractor and SPO engineering changes will be documented. Where inventory equipment is identified by contractors, the SPO will determine availability of the items. Special emphasis will be directed by the SPO to insuring maximum use of equipment in the DOD inventory and to meeting rather than exceeding or falling short of total system requirements by the equipment design requirements. Where it is apparent that the contractor is undertaking a design effort that clearly exceeds the state-of-the-art, allocated funds, or imposed schedule, appropriate action will be taken to redirect such efforts.

c. The prime objective of this system requirements review is to assure that the definition effort is proceeding in a logical manner toward its ultimate objective. All contractors shall participate in this review. The SPO will assure that the review is conducted so that creative or proprietary differences between contractors are not compromised.

Block 31. Update System Specification.

a. The contractors shall use the results of the engineering effort to update and refine their portions of the System Specification specified

in the phase IB contract. Though shown on a step function to indicate a significant milestone, maintaining an accurate system specification is a continuous effort. Particular attention shall be paid to the design/performance parameters of the subsystems based on interface requirements identified in schematic diagrams. It shall be the function of the SPO deputy director for engineering to assure that subsystems are properly interfaced and that overall system integrity is maintained through the use of the System Specification. The system engineering documentation provides source information for the requirements contained in the System Specification. Changes to this documentation shall be reflected in the System Specification. Changes to the System Specification include expansion of the Specification Tree and development of the CEI list to reflect equipment selected by the activity described in block 28.

b. Updating and refining the System Specification may change the performance/design requirements which were identified as part of the program requirements baseline. Changes to these requirements shall be accomplished using system requirements ECP's in accordance with exhibit VIII, AFSCM 375-1.

Block 32. Develop End-Item Maintenance Functions for Critical RPIE Subsystems, AVE, and/or OGE.

a. The next group of blocks describes the maintenance design engineering actions conducted to define the maintenance design requirements of the system. The ultimate goal of this series of actions is to assure that maintenance implications are considered in depth prior to the additional preliminary design of operations equipment/facilities. It is necessary to consider the sequential maintenance function requirements leading to the selection of equipment (reference block 34) and the maintenance function requirements generated by the equipment previously selected (reference block 28).

b. The first action in this group of blocks is to indenture the operations equipment, defined by the preceding actions into components and to determine the maintenance functions which must be performed on these components.

Equipment maintenance can be categorized into standard functions. It is, therefore, possible to select from a standardized list the equipment maintenance functions required. The list contains the following functions: test-checkout, calibrate, adjust, remove-install, replace, repair-overhaul, protect-service, visual check-inspect, clean-purge-filter-contamination, composite test, system alignment, store-handle, monitor-operate, and interface. The end-item maintenance sheet (reference attachment 1) contains the standard list of maintenance functions and shall be used to record the maintenance requirements for each CEI. For facilities, only critical RPIE subsystems shall be analyzed utilizing end-item maintenance sheets to determine detail maintenance requirements.

c. In identifying the functions required to maintain the AVE and/or OGE and critical RPIE subsystems appropriate considerations of the various modes shall be included. For example, (1) the preventive or corrective maintenance required to keep the system operating while the AVE and/or OGE are in their operating configuration (system installed); (2) the maintenance required on each reparable AVE and OGE assembly which may be removed/installed in the system installed configuration (e.g., modular drawers in equipment racks); and (3) maintenance required on each reparable assembly which may be removed/installed only after its next higher assembly has been removed from the system installed configuration (e.g., computer elements, valves, and printed card circuits).

d. Maintenance functions for each item of AGE and/or OGE and for critical RPIE subsystems shall be identified down to the lowest reparable nonstandard component. In determination of the maintenance functions to be performed on AVE and/or OGE, the following sequence shall be used. First the CEIs are analyzed as a unit. The next step is to indenture each CEI into its major assemblies, then to indenture each major assembly into its lowest reparable components. The above sequence of indentures shall be listed consecutively on the end-item maintenance sheet. At this time it will be impossible to indenture the equipment to the lowest reparable level. The basic intent is to

accomplish the lowest level of indenture possible and to develop lower level indentures as additional information becomes available. The purpose at this time is to assure that design parameters of the equipment selected do not impose excessive or impossible maintenance requirements upon the system.

e. Maintenance functions provide a basis for apportionment of effectiveness values to CEIs and components predicted to be the repairable at organizational and field levels; design of maintenance equipment; determining human performance requirements for maintenance; and provisioning. Attachment I specified the detailed requirements for determining the maintenance requirements utilizing a manual procedure.

Block 33. Develop Design Requirements for End-Item Maintenance Functions.

a. Following the establishment of the functions required to maintain the operations CEIs (critical RPIE subsystems, AVE, and/or OGE), it is necessary to translate these functions into design requirements. The contractor shall record the product of this effort on the RAS. Maintenance implications of the TSRP functions must be considered along with the AVE and OGE. Not only do facilities design requirements derive from AVE and OGE maintenance functions, but also the facilities themselves must be maintained, thereby imposing maintenance requirements on facilities design and, in some cases, requiring MGE for critical RPIE subsystems. The RAS provides the documentation necessary to insure consideration of each function and establishment of corresponding design requirements.

b. After maintenance design requirements are determined, it is necessary to assure that the requirements are either incorporated as maintenance design features into the operations CEIs or that the design requirements are met by MGE required in support of the operations CEIs. An example of the former would be the utilization of a computer accomplishing a guidance function to check CEIs employed in performing the flight control function. An example of the latter would be a test set required to verify that adequate power is being pro-

vided. In the case of the test set, jacks would have to be designed into the AVE to permit the performance of the checkout function.

c. Each maintenance function entered on the end-item maintenance sheet shall contain corresponding design requirement entries on the RAS. The end-item maintenance sheet fulfills a purpose similar to that of the functional diagram: namely, that of delineating the functions which the system elements have to perform. The RAS is used for both the end-item maintenance sheets and the functional diagrams to translate functions into design requirements. These requirements shall be stated in specific terms. For example, input and output voltages should be specified for a maintenance decoder which is required to replace the OGE decoder during test. An example of a specific statement might be "Internal test points shall be provided and must be brought out to test connectors on the drawer fronts to allow the connection of the test equipment."

d. Facility design requirements emanating from AVE and/or OGE shall be entered in the "Facility requirements" column of the RAS. This column contains the data for FSE to determine facility equipment required to support AVE and/or OGE.

e. The maintenance design requirements determined will be preliminary in nature due to the limited preliminary design. The detailing of the requirements will necessitate additional preliminary design of the CEI. Nevertheless, sufficient information concerning requirements should be available to make a preliminary assessment of the design approach to be pursued. As a minimum, sufficient information will have been acquired to proceed with the establishment of the initial parameters of the MGE and facilities required to support the AVE and/or OGE.

Block 34. Develop Detailed System Maintenance Functions.

a. While this action is proceeding concurrently with the action required by block 32, it is a distinctly different effort. The action of block 32 is concerned with the maintenance requirements generated by CEI design. This action is concerned with maintenance requirements generated by system design. While there

will be an interactive effect between the two efforts, the levels of functions are distinctly different.

b. The contractor shall identify system maintenance functions on functional diagrams in the manner prescribed for the formulation of operations functions. As in the case of operations functional diagrams, it is not anticipated that functional diagrams will be indented below the third level. System maintenance requirements were translated into gross functions such as "Launch and launch control maintenance," "Support base maintenance," and "AVE recycle and depot maintenance," on the top-level functional diagrams (reference attachment 2). While gross maintenance requirements have been previously incorporated into the initial design parameters of the AVE and/or OGE and facilities, the detail definition of system maintenance functions will depend upon the specific AVE and/or OGE selected, i.e., it is necessary to determine "what" before the "how" can be thoroughly explored.

c. Each gross function is indented to the level necessary to insure adequate description of the system maintenance requirements in functional terms within the design parameters of the AVE and/or OGE and facilities previously selected. For example, in the case of a space system, it will be necessary to identify the functions which must be performed for the preventive and corrective maintenance of the space vehicle, booster, guidance package, the AVE removable from the booster, including separate stages as appropriate, and other identified OGE. Thus, "Support base maintenance" functional diagrams would be prepared to cover those functions involving the receipt, handling, storage, and transportation of out-of-commission AVE and OGE at the support base. "Launch and launch control maintenance" subfunctions would be established to cover the functions involved in removing and replacing the space vehicle and major end items of the booster: e.g., guidance package and propulsion stages. Maintenance function requirements such as malfunction isolation or corrective action after discovery of a malfunction would also be covered in the "Launch and launch control maintenance" subfunction.

d. The contractor shall assure that maintenance functional diagrams are indented to the level necessary to completely describe the maintenance functions imposed by system requirements. Detailed requirements for the preparation of functional diagrams are covered in attachment 1.

Block 35. Develop Design Requirements for System Maintenance Functions.

a. Following the establishment of the system maintenance functions, the contractor shall develop requirements for a design to satisfy the prescribed functions. This task shall employ the methodology used in determining operations design requirements (reference block 22). Design requirements shall be determined for each function and shall be documented on the RAS. In determination of maintenance design requirements, previously selected AVE and/or OGE equipment will be a major constraint. For example, the design requirements necessary to satisfy the function "Remove command module" will have been predetermined to a large extent by the design parameters of the command module, including size, weight, environmental requirements, etc. This is not to imply that trade studies between maintenance and operational requirements should not be considered but, rather, that there is a direct relationship between selected AVE and/or OGE and maintenance design requirements. Alternate methods for meeting prescribed functions shall be considered in depth.

b. Facility design requirements for TSRP equipment and structures, building, etc., will be recorded on the RAS in the same manner as other equipment. In this case, the "Facility requirements" column will describe the interfaces between facilities and other system equipment: e.g., OGE designed by other contractors. The establishment of design requirements in a systematic manner through the use of standardized documentation provides the means for assuring that design interfaces between equipment and facilities have been properly considered and that a communication link has been established between the various contractors involved. This requirement is especially significant in the case of long-lead-time facilities where construction must begin prior to the com-

pletion of the design of equipment. In this case, the facility design becomes a constraint upon the design of the equipment: e.g., booster length will be restricted by the size of the silo which provides environmental protection and control.

c. The stability and depth of design requirements recorded in the RAS will depend upon the extent of design information available. When additional design information is acquired, design requirements will become more detailed and stable. In the determination of design requirements, the preselection and grouping of design requirements on the basis of preconceived equipment and facility configuration should be avoided.

Block 36. System Requirements Review.

a. This action is similar to the activity described in block 23 but shall be primarily directed toward a review and evaluation of the maintenance functions and requirements. During this review, the SPO will assess the progress of the definition effort and identify the working effectiveness of participating contractors.

b. Maintenance functions developed will be reviewed to determine that the support concepts are valid, technically feasible, and understood by the participating contractors. Functional diagrams will be reviewed for continuity and accuracy. The allocation of functions to participating contractors will be reviewed to assure that interfaces have been adequately covered. The RAS will be reviewed to assure that explicit requirements have been entered for functions identified on the functional diagrams and end-item maintenance sheets. It will not be the function of the review to perform an on-the-spot technical integration of the system but, rather, to review how well the integration effort has been accomplished. As a product of the review, the SPO will identify and assure resolution of any technical integration problems emanating from the definition effort.

c. To assure that this review and all subsequent reviews accomplish the intended purpose and do not delay the contractor's effort during a critical part of the definition or acquisition phase, it is essential that the contractors and the SPO be equally responsive to actions resulting from the reviews.

Block 37. Perform Trade Off Studies (Maintenance Elements of the System).

a. The next sequence of engineering actions (blocks 37, 38, 39, and 40) is directed toward the definition of the basic maintenance elements of the system (MGE, AAE, facilities, and personnel). While each action is discussed separately, the actions are interrelated and must be performed concurrently. The objective of this series of engineering actions is to provide a firm basis for the selection of maintenance system elements which best fit the design requirements previously specified. For achievement of this objective, it is necessary to evaluate design alternatives on the basis of time, cost, and performance. In some cases, engineering judgment will be adequate to justify the design choice or there will be no alternatives to choose from, while in other cases alternatives will have to be considered in detail before valid decisions can be made. The contractor shall accomplish trade studies necessary to provide technical substantiation of requirements for end items, facilities, personnel, and training required to accomplish maintenance functions.

b. This action shall employ the rationale used in conducting trade studies for operations elements (reference block 24). Maintenance trade studies shall be reported in accordance with the requirements of attachment 1. Results shall be reflected on appropriate functional diagrams, RASs, time-line sheets, design sheets, schematic diagrams, and end-item maintenance sheets. Appropriate feedbacks shall be made to operations requirements where maintenance selections result in changes to previously selected operations elements. The objective of these trade studies is to achieve a system balance based on the consideration of total requirements. By placing specific emphasis on maintenance as a separate entity, the contractor and the SPO are able to visualize the entire system. Trade study results will provide a firm basis for the allocation of maintenance functions and design requirements. Maintenance trade studies to be conducted at this time are those required to support the actions specified in blocks 38, 39, and 40.

Block 38. Develop Design Requirements for Maintenance End Items.

a. A critical step in the design process is to develop the design requirements into deliverable CEI packages. This step is based on previously acquired design knowledge, the results of trade studies, and the description of the system in functional terms. The contractor shall determine how system requirements will be met in terms of maintenance CEIs. Additionally, aerospace ancillary equipment (AAE) required to support the maintenance and operation design shall be identified. Specific steps required in the development of design requirements for maintenance end items are similar to those presented in block 23 for operations CEIs.

b. The task of design engineering becomes one of grouping the design requirements appearing on the RASs through the use of schematic diagrams into CEIs. Results of the grouping appear as design requirements on the design sheets. Each design requirement appearing on the RAS shall be covered on one or several design sheets. These design requirements will be further expanded to assure that quantitative input/output information is included which adequately describes the total design requirements of the CEI to be designed, tested, and delivered.

c. MGE resulting from this activity is first-level maintenance equipment: i.e., primarily organizational and, in some cases, field equipment required in support of operations equipment. AAE resulting from this action is that equipment required to train personnel or to install, assemble, checkout, test, or repair the system. These items of equipment do not become organizational equipment: i.e., they are "dead ended." Examples of AAE are flight-test instrumentation equipment, safety-destruct equipment, and a mission simulator. Detailed requirements for preparing design sheets are presented in paragraph 6.0, attachment 1.

Block 39. Develop Maintenance Requirements for Facilities.

a. The FSE shall translate and group the facility design requirements for maintenance into facility CEIs using the methodology that was employed for grouping facility design re-

quirements for operations (reference block 28). The design requirements contained on the RASs shall be grouped by means of schematic diagrams and recorded in Facility CEI Specifications and on design sheets. Existing facilities shall be identified through the use of Inventory Equipment Requirements Specifications.

b. Because of leadtime requirements, facility construction is often required prior to the completion of design and fabrication of equipment. Furthermore, constructed facilities usually do not provide flexibility for changes (e.g., launch facilities and hangars, when hardened, are costly to modify). Therefore, the early establishment of equipment and facility interface control is critical.

c. The facility interface sheet (reference para. 7.0, attachment 1) shall be used by all contractors to document and transmit facility requirements generated by the design requirements of other equipment. This sheet provides a means for recording and transmitting facility interface information from nonfacility contractors to the FSE and will become the basis for the development and assessment of maintenance facility design requirements. The facility interface sheet serves as an interface control document for insuring identification of equipment requirements having an impact on facilities. Facility interface sheets are to be used by the FSE to record facility interface information resulting from the design requirements for RPIE. For example, a fixed crane or hoist defined as maintenance RPIE will require facility power and structural support. A facility interface sheet for the crane would summarize these requirements for input to the preparation of design sheets for the power or structural support facility items.

Block 40. Develop Requirements for Maintenance Personnel and Training.

a. Sufficient information has been acquired to specify the initial requirements for maintenance personnel, training, training equipment, and procedural data. Requirements for maintenance personnel and training shall be developed by the contractor using the RAS the same as described in block 27 for operations personnel and training requirements.

b. As in the case of operations personnel and training requirements, the requirements specified for maintenance personnel and training will be preliminary in nature. The identification of complete personnel and training requirements is dependent upon additional design effort and the identification and selection of the total MGE, AAE, and facilities required for maintenance. However, sufficient information can be acquired concerning personnel and training requirements for an evaluation of the selected system elements: e.g., personnel, facilities, and equipment on the basis of the design requirements appearing on the RAS and design sheets.

c. The personnel and training equipment entries on the RAS will provide information to answer questions such as: Has a proper balance between the various elements been achieved? Are certain areas overloaded? Are skill levels and tasks too demanding? Are training requirements excessive to the capabilities for training? Should a higher degree of automation be achieved?

Block 41. Select MGE, AAE, and Maintenance Facilities.

a. The contractor shall select the MGE and AAE necessary to support the operations elements previously selected in block 28. The contractor shall select the additional facilities peculiar to maintenance which are necessary to satisfy the facility design requirements developed in blocks 38 and 39. This activity represents the first iteration of engineering effort to define the total list of maintenance equipment. All major items of MGE, AAE, and facilities required shall be identified.

b. Subsequent steps include the balancing of selected MGE against previously selected facilities and/or OGE, the analysis of MGE to determine additional maintenance requirements and identification of related MGE, AAE, and facilities for test and activation. Maintenance equipment, facilities, and AAE selected will be identified on the CEI list and the specification tree in the System Specification.

Block 42. Identify High-Risk Areas and Long-Lead-Time Items.

a. This block describes the action directed toward the identification of high-risk maintenance areas. The action required is similar to that performed under block 29 and is a result of the trade studies described in block 37. In trade studies, high-risk areas may have been identified. For example, the use of an airborne computer to perform checkout functions may become a high risk until sufficient experience is accumulated to determine that the computer can accomplish both functions. Other examples of high-risk areas might be (1) the feasibility of developing an automatic malfunction detector of the total system in a system installed configuration; (2) the lead time involved in constructing a new maintenance facility where the total requirements for the facility (in terms of specific environmental tolerances, power requirements, etc.) will not be established in time to meet construction start dates; and (3) the uncertainty of availability of Government test facilities at the time required.

b. There are many maintenance and support factors which must be considered; however, the prime emphasis shall be on major trouble spots, and the criteria for the selection of these can only be based on sound engineering judgment. Where a trouble spot is identified, it may be possible to eliminate or reduce the risk through the selection of an alternate item of equipment.

Block 43. System Requirements Review.

a. The SPO will review effectiveness factor, apportionment, personnel requirements, high-risk areas, and the hardware selected as stated in block 41. Documentation leading up to the selection of the equipment, such as maintenance-oriented functional diagrams, schematic diagrams, RASs, design sheets, and time-line analyses shall be reviewed for technical adequacy and system continuity. Specific attention shall be directed toward the detail review of interface documentation, high-risk areas, and results and progress of selected trade studies involving maintenance. Where inventory equipment has been identified, the SPO shall determine availability of the items.

b. As in block 30, the purpose of this review is to assure that appropriate progress is being made in defining the system and that actions required as a result of previous reviews have been accomplished. Where interfaces or other technical problems cannot be resolved between contractors, the SPO shall arbitrate to assure that necessary technical decisions are reached and that the definition process is permitted to proceed in a timely manner on a total system basis.

Block 44. Perform Trade-Off Studies (Operations Design vs. Maintenance Design).

a. The purpose of this step is to integrate the operations design with the maintenance design to optimize all major system elements. The contractor shall perform any necessary trade studies to insure a balance of selected operations and maintenance equipment, facilities, personnel, and related test and activation requirements for the purpose of evaluating the definition accomplished in terms of meeting rather than exceeding cost, time, and performance requirements.

b. These studies shall consider how well the system defined has considered effectiveness factors and the requirements for performance, maintenance, personnel, development and test, and production. The consideration of factors involved in system downtime such as maintenance and personnel requirements represents a preliminary assessment of the effect that a particular configuration has upon elements of the system involved in maintenance (MGE, personnel, facilities). Decisions resulting from the comparative analysis of operations and maintenance requirements shall be reflected in the system engineering documentation.

Block 45. Prepare Detail Specifications.

a. One of the major objectives of the system engineering process is to provide the foundation for the uniform specification program. System engineering has systematically identified and defined complete "design-to" requirements and related category I and II test requirements for each CEI. The design sheets which have been prepared shall now become the "Requirements and quality assurance" sections (3 and 4) of

the Part I Detail Specifications for prime equipment, facility, identification items, and critical components (reference exhibits II, III, IV, and VI, AFSCM 375-1). Additional specification sections required by AFSCM 375-1 shall be prepared and combined with sections 3 and 4 to form the initial version of the Part I Detail Specification. Inventory Equipment (EI) Specifications shall be developed in accordance with exhibit V, AFSCM 375-1, and as an integral part of the system engineering process. Appropriate changes and additions shall be made to the System Specification to reflect the content of the Detail Specifications prepared.

b. The Part I Detail Specification, as the basic document for specifying all design and test requirements, provides a single line of communication between the designer and the SPO. The accumulation of "design-to" and test information in the Part I Detail Specifications results in establishing the design requirements baseline at the completion of the definition phase (reference chapter 2, AFSCM 375-4 16 March 1964). Though the block portrays specification preparation as a single activity, a continuous relationship must be maintained between operations design and maintenance design and the uniform specification program. As additional items of equipment are selected, corresponding specifications shall be prepared. Changes in design and test requirements shall be incorporated in the appropriate specifications.

Block 46. Update Design Requirements for Operations Functions.

a. The actions described in blocks 46, 47, 48, and 49 represent an expansion in detail of the previous definition effort. Changes to operations functions, design requirements, test requirements, activation requirements, and requirements for equipment, facilities, personnel, and training resulting from maintenance considerations shall be recorded in the system engineering documentation.

b. Design requirements for operations functions shall be updated by the contractor through the use of functional diagrams, RASs, trade studies, and time-line sheets. The reallocation

10 March 1966

AFSCM 375-5

of design, test, and activation requirements resulting from trade studies, as well as the assignment of maintenance functions to operations equipment, shall be recorded in the RAS and time-line sheets.

Block 47. Update Design Requirements for Operations End Items.

a. The contractor shall update the design and test requirements contained in the applicable Detail Specifications. This is accomplished in the same manner as initial design and test requirements for CEIs were developed (reference block 25), with the exception that the schematic diagrams and Detail Specification now contain maintenance design features: e.g., test taps, test gages, and quick disconnect requirements. Changes to Detail Specifications will range from minor changes to the deletion, addition, and repackaging of CEIs. In the case of additional CEIs, it will be necessary to prepare backup end-item maintenance sheets and RASs to assure that maintenance implications have been considered.

b. This action represents applying the results of the efforts made in integrating operations, maintenance, test, and activation requirements. The contractor shall assure that design requirements entered in the Detail Specifications include the decisions made as the result of trade studies and additional design efforts. For example, in the use of electronic systems, an updating of the design requirements for the computer program would:

(1) Specify detail performance and design requirements for the computer program CEIs and identifiable elements within these end items; specify constraints, limits, and standards necessary to insure interface compatibility with the other computer programs and equipment CEIs; and specify details of the functions to be performed by each computer program CEI. This includes necessary logic, mathematical formulas, decisions, sequencing, data formats, data base requirements, etc.

(2) Specify computer programs CEI performance in terms of the functional requirements. This includes requirements which establish the efficiency/effectiveness of the CEIs as viewed by the user.

(3) Specify detail requirements for verification of performance and design of the computer program CEIs and general test methodology to be used.

Block 48. Update Operations Requirements for Facilities.

a. Changes resulting from balancing operations and maintenance requirements and solutions, as well as test and activation requirements and solutions, shall be reflected in facility documentation. The contractor shall make appropriate changes to the Part I Detail Specifications, RASs, facility interface sheets, facility schematic diagrams, and facility perspectives developed earlier (reference block 20) to assure that the impact on facilities has been duly considered. Changes to facilities will vary from minor changes to the deletion or addition of equipment and facilities.

b. Requirements developed from the actions specified in blocks 26 and 39 have identified facilities to fulfill a direct support functional role such as alert hangars, protective silos, runways, propellant loading facility, and maintenance docks. It is now possible to identify new facility requirements imposed by the facility design itself (i.e., electric power, emergency power, deluge, etc.) and to further define the requirements imposed on facilities by the system test and activation requirements.

Block 49. Update Requirements for Operations Personnel and Training.

a. Changes to personnel and training requirements to support operations, as well as test and activation, shall be incorporated on RASs and time-line sheets to reflect the personnel and training aspects of the system that have been considered as part of the trade studies and design effort. The personnel requirements of the system engineering documentation shall be updated and, where contractually required, further detailed into the initial QQPRI document in accordance with the requirements of MIL-D-26239. This document establishes the duties and positions of personnel required to operate, maintain, and control the system and defines the basic tasks assigned or allocated to the positions. Physical location, time to accomplish, and indi-

vidual technical capability are major factors in determining personnel positions and duties. Assignment of tasks to positions must be done on a logical basis.

b. Concurrently with the formulation of the initial QQPRI, the system engineering documentation pertaining to recommended training equipment and extent of training required shall be updated and, where contractually required, restructured into a training equipment planning information (TEPI) document. The formulation of the system training equipment package is dependent upon the effective grouping of training equipment in relation to the extent of training required on the positions identified in the initial QQPRI. Close coordination regarding anticipated student load and availability of training facilities is required between the SPO, ATC, and the using command in order to achieve realistic training requirements.

Block 50. System Design Review.

a. The SPO will review the system design approach and the system elements defined. The review is to identify how the final combination of operations, maintenance, test, and activation requirements has affected program concepts: affected quantities and types of equipment: established new or modified facilities: and established new or modified personnel requirements. The SPO will determine that the requirements for each system element are essential and are in consonance with the program requirements baseline. The review is to determine whether the system design defined presents an optimum balance of system elements and that a technical understanding of all requirements has been reached.

b. This is the last in-process review during phase IB, and it is essential that the documentation developed be critically examined to insure attainment of the objectives of the definition phase. The documentation to be available for review shall include functional diagrams, RASs, trade study reports, schematic diagrams, time-line sheets, initial Part I Detail Specifications, facility interface sheets, facility perspectives, end-item maintenance sheets, and, where applicable, the initial QQPRI and TEPI.

Block 51. Update System Specification. This action represents the final iteration of the System Specification during phase IB. The contractor shall incorporate into the System Specification, the decisions resulting from the engineering required by blocks 32 through 50. Changes to the specification tree shall be made to identify the equipment resulting from the actions described in blocks 41 and 47. The system specification shall incorporate appropriate system engineering documentation: e.g., functional diagrams to describe functional requirements and schematic diagrams to portray interfaces.

Block 52. Complete Detail Specifications. The Detail Specifications initiated in block 43 shall be completed at this time. The contractor shall complete these specifications on the basis of the system engineering documentation accumulated. The Part I Detail Specifications for the operational, utility, and support computer programs may not be completed until Part I Detail Specifications for the prime equipment have been prepared. The completed specifications shall be part of the phase IB final report (reference AFSCM 375-4) and will become contract requirements for the design and development portion of the acquisition phase.

Block 53. Estimate Quantities of AVE and/or OGE, Facilities, and AAE. The contractor shall estimate the quantities of AVE and/or OGE, facilities, and AAE supporting the operations mode of the system. Quantity determination is based on variables such as force size, reliability, alert status requirements, and maintenance downtime and, therefore, bears a direct relationship to the design approach selected. The impact of the selected design approach on the quantities of equipment and facilities shall be evaluated and assessed. Where necessary, specific trade studies shall be conducted to assure that optimum quantity requirements are achieved. Quantity determination can only be estimated at this time: nevertheless, these gross estimates are required to aid in determining program cost and schedule estimates for phase II and for the period beyond phase II. As design becomes more definitive, these initial estimates shall be adjusted accordingly.

Block 54. Estimate Quantities of MGE, Maintenance Facilities, and AAE. Figure 5 shows a parallel activity in the maintenance design line for determining the quantities of the MGE, maintenance facilities, and AAE supporting the maintenance test and the activation modes of the system. This action is similar to that described in block 53 and is a predecessor of blocks 70 through 73 (maintenance loading) and blocks 86 and 87 (provisioning). The test and activation system engineering documentation shall be used as a basis for the system allocation document required by exhibit XI, AFSCM 375-1. These quantity estimates shall be updated as detail designs become available.

Block 55. Provide Inputs to Phase IB Final Reports and the Phase II Proposals. This action depicts the relationship between engineering activities and the final report, and the contractor's firm proposal for the acquisition phase (phase II). The phase IB reports and phase II proposals (reference AFSCM 375-4) shall contain the cumulative results of system engineering. Inputs to the final report include:

- a. Information acquired from trade studies required to summarize their results.
- b. Functional diagrams, schematic diagrams, RASs, facility interface sheets, facility perspectives, and end-item maintenance sheets describing the rationale and design approach selected.
- c. The System Specification and Part I Detail Specifications emanating from the system engineering documentation.
- d. The list of required procedural data based on information acquired from the RASs.
- e. Technical information necessary for the preparation of the contractor's phase II program management plans.
- f. The adequacy of the logistical support plan for the acquisition phase.
- g. The identification of high-risk areas and long-lead-time items.
- h. Information necessary for the development of incentive features.
- i. Estimates of the quantities of equipment, personnel, and facilities required.

3.3 Phase IC:

Block 56. Technical Evaluation and System Engineering Synthesis.

a. Upon receipt of the contractor's phase IB final reports the SPO will (1) evaluate the technical portions of the final reports to determine whether the system defined is technically sound; (2) evaluate high-risk areas identified; (3) evaluate the final report to determine whether the contractor has satisfactorily fulfilled technical tasks of the phase IB statement of work; and (4) synthesize the best features of each contractor's design approach into an optimum system within the overall performance, cost, and schedule requirements and proprietary limitations.

b. Engineering synthesis shall be made only when major deficiencies are in evidence or major advantages would accrue. During this synthesis the SPO will generate new or revised functional diagrams, RAS, trade study reports, schematic diagrams, time-line sheets, Detail Specifications, and effectiveness models, if the requirements specified in the final report do not represent the optimum system or are not conducive to fixed-price, fixed-price incentive, or cost-plus-incentive-fee contracting.

c. Evaluation of each final report and phase II proposal will determine the technical adequacy of the following documentation in light of the program requirements baseline:

- (1) The updated System Specification.
- (2) Functional diagrams and related RAS and time-line sheets.
- (3) Trade study reports, system effectiveness models (including cost effectiveness data), and other technical backup data.
- (4) Part I Detail Specifications and related schematic diagrams and facility interface sheets.
- (5) Contractor's phase II program management plans.
- (6) End-item maintenance sheets and related maintenance RAS.

d. The Part I Detail Specifications, modified as a result of evaluation and synthesis, constitute the defined design requirements baseline.

4.0 Acquisition Phase Requirements:

Block 57. Inputs to Development Contracts. The products of the definition phase (namely

the System Specification and the Part I Detail Specifications, as amended by program redirection and contract negotiation) serve as the basic requirements for the design and development contract. Engineering definition continues throughout the acquisition phase until the system has been described by Part II Detail Specifications and drawings. As additional detailed design information becomes available, changes to existing requirements will be necessary. For example, category I test results may dictate design changes and the necessity for further definition. A line item will be included in the design and development contract to provide for defining additional MGE, AAE, and facilities in order to permit subsequent development of these items. In order to assure that design efforts are constantly directed toward system requirements during phase II, it is necessary to apply progressively tighter controls upon the engineering process. For example, the control during design and development will be achieved by contracting against the Part I Detail Specifications which constitute the approved design requirements baseline. The steps necessary for additional definition of design and for controlling design in a systematic fashion are described in subsequent blocks.

Block 58. Accomplish Preliminary Detail Design.

a. Based upon the System Specification and the Part I Detail Specifications, the contractor shall initiate preliminary detail design. The effort may include developing detail logic diagrams, engineering breadboards, mockups, etc., required to complete preliminary detail design. The evolving system design will begin to identify detailed constraints and additional requirements applicable to the maintenance, manufacturing, and depot-level definition effort.

b. Preliminary design for facilities will initiate engineering effort for the preparation of Part II Detail Specifications (traditionally called Facility Construction Contract Plans and Specifications) in accordance with exhibit III, AFSCM 375-1. Part II Detail Specifications for facility elements which are not likely to be affected by system change will be prepared first, with progressive phasing in of Part II Detail Specifications for higher risk elements as opera-

tion and maintenance requirements are validated.

Block 59. Conduct Preliminary Design Reviews (PDR) on Operations Equipment/Facilities.

a. Preliminary design reviews (PDR) shall be conducted by the contractor on each item of AVE, OGE, AAE, and facilities in accordance with the requirements specified in exhibit XIV, AFSCM 375-1. PDRs shall be conducted for the purpose of assuring that the engineering design approach selected to satisfy the specified design requirements is acceptable. It is necessary to determine a specific design approach in order to proceed with more detailed design. This may lead to the synthesis of alternative approaches that must be studied and evaluated. The PDR and its relationship to other reviews and baseline management is described in chapter 4. PDRs are not intended to restrict design flexibility, particularly detail design, but are intended to prevent random, uncoordinated changes.

b. PDRs shall be conducted on related groups of operations equipment and facilities in order to insure direction of follow-on detail design toward meeting established design requirements. It will be recalled that the Part I Detail Specifications, against which the design and development contract was negotiated, formed the design requirements baseline. Changes to the requirements contained therein are subject to contract negotiation and change. Therefore, engineering efforts directed outside the purview of existing requirements in Part I Detail Specifications are without contract reference.

c. Since the design of operations equipment and facilities determines the requirements for maintenance equipment and facilities, it is essential that an operations design approach be established prior to the initiation of detail maintenance design and detailed test and activation design. Therefore, a PDR on operations equipment/facilities must be conducted before the commencement of detail design for maintenance, test, and activation equipment. The PDR should include consideration of the maintenance concepts resulting from blocks 32 through 43. PDRs shall be conducted on an incremental basis. Each review shall be an

integrated review encompassing all design engineering areas and technical disciplines having an input to the CEI design. Separate formal design reviews shall not be conducted to determine adequacy of a particular design engineering area (e.g., electrical or mechanical) or technical discipline (e.g., effectiveness, reliability, maintainability, safety, or human engineering). Action items resulting from PDRs shall be covered contractually and will be binding upon PDR participants. Schedules and the technical agenda for the PDRs shall be established by the contractor subject to approval by the SPO. The SPO may elect, however, to participate in formulation of the agenda and PDRs on high-risk or complex designs. Attendance at PDRs by the SPO or the designated AFCMD representative will be at the option of the SPO.

d. PDRs shall be conducted on facilities and critical RPIE subsystems, by the AFSC division civil engineering activity to review the preliminary design effort to verify compatibility of the preliminary design approach with Part I Detail Specifications. This will include reviews of the facility support elements (maintenance data, personnel, etc.) developed to date and changes resulting from updated maintenance requirements. TSRP and critical RPIE subsystems design should be approximately 50 percent complete before these reviews are held. Industrial facility and NSRP design should be approximately 70 percent complete before PDRs are conducted. Though the data for facility design are greatly dependent on the development of other system elements, construction leadtimes often force early freezing of facility requirements and, therefore, influence the phasing of facility PDRs with respect to the rest of the system. Nevertheless, the basic function of the PDR for facility CELs is the same as for other CELs.

Block 60. Validate Operations Equipment/Facilities Part I Detail Specifications.

a. The contractor shall incorporate the results of the PDR into the appropriate AVE, OGE, AAE, and facility Part I Detail Specifications. The PDR determined that the design approach was feasible and sound from a design, development, test, and activation view and that the per-

formance/design requirements specified in Part I Detail Specifications can be effectively met. PDRs therefore, serve to validate the Part I Detail Specifications of the equipment/facilities.

b. Changes to Part I Detail Specifications required as the result of PDR actions shall be made using design requirements ECPs in accordance with exhibit IX, AFSCM 375-1.

Block 61. Initiate Detail Design of Operations Equipment/Facilities.

a. The detail design effort transitions from the definition of detail requirements to the definition of detail design solutions. While detail design may have been accomplished to varying degrees during the conceptual and definition phases, the major detail design effort will not have started until after the design requirements baseline for the system has been approved. The subsequent completion of PDRs results in an approved design approach and establishes a firm foundation for detail design. The result of a PDR influences continuance of detail design in accordance with the approved design approach. With the advent of detail design, engineering documentation begins to evolve as detail drawings, interface control drawings, and Part II Detail Specifications for the operations equipment/facilities. The documentation represents a further detailing of the design approach validated as a result of PDR.

b. In the case of computer programs, the detailing of the design approach consists of (1) detail descriptions of individual computer programs or program packages according to input/outputs and functional requirements; (2) detail descriptions of program sequencing, timing, mode of operation, and storage allocation requirements; (3) specification of interprogram communication requirements and executive control features for the computer programs; and (4) specification of limits and tolerances, and the translation into data base storage requirements, the data base element characteristics, and computer program accuracy requirements.

c. Control of detail drawings shall be exercised by means of the contractor's engineering release system (reference exhibit XII, AFSCM

375-1). SPO control of design requirements will be exercised using Part I Detail Specifications. Rigid drawing and Part II Detail Specifications control will not be enforced until after FACI in order to provide for flexibility in detail design.

Block 62. Perform Trade-Off Studies (Maintenance Elements of the System). The contractor shall identify and conduct trade studies of maintenance, test, and activation requirements to determine detail requirements imposed by the AVE or OGE, MGE, and AAE selected during phase IB. Typical subjects for study include levels of maintenance, quantity of equipment, estimated range and depth of required spares and spare parts, facility utilization, test and activation equipment, and total predicted costs. Since there are detail maintenance considerations which have extensive impacts on the total system such as downtime, costs, and in-commission rates, these detail maintenance areas shall be handled in the same systematic manner as were the major operations and maintenance trade studies conducted earlier. The trade studies shall be documented as required by attachment 1. The performance of trade study effort requiring a change in funding of the phase II contract shall be subject to negotiation.

Block 63. Develop Detail Maintenance Functions.

a. Sufficient preliminary design on AVE or OGE, MGE, AAE, and critical RPIE subsystems will have been accomplished to allow more detailed analyses of maintenance requirements. The next series of blocks (blocks 63 through 67) depicts the areas of revising and detailing of maintenance requirements.

b. The contractor shall identify maintenance functions which must be performed on previously selected MGE and related AAE using end-item maintenance sheets. This action is similar to that described in block 32, and includes the expansion of end-item maintenance sheets previously prepared for AVE, OGE, AAE, and critical RPIE subsystems. Maintenance functions shall be indentured down to the lowest repairable nonstandard component for each CEI.

c. Analysis of maintenance requirements for critical RPIE subsystems procured under the MCP will be limited to the level of hardware detail contained in the Part II Detail Specifications and supporting drawings (reference block 58). Where detailed equipment selection or design is left to the option of the construction contractor, the detailed analysis of maintenance requirements to the component level will be delayed until component selection is made and design documented.

d. Sufficient information will be available to determine the requirements for depot-level maintenance. The following paragraphs shall apply for determining depot-level maintenance requirements:

(1) The contractor shall review and evaluate production support plans for the purpose of insuring the maximum continued utilization of production equipment for depot-level maintenance. Contractor production tooling shall be evaluated for possible application to depot maintenance. Whenever a depot function is identical to a function performed by the contractor in production, the production equipment shall be recommended for use by the depot.

(2) The SPO will identify the CEIs which the contractor is to analyze for depot-level maintenance requirements.

(3) The identified CEIs shall be analyzed to the indenture level required to determine special repair activities (SRA) repairable items, and the depot tooling and test equipment required to perform SRA repair functions. Peculiar depot tooling and test equipment shall be analyzed to the level required to identify any peculiar maintenance equipment and all calibration requirements. Nonrepairable parts shall not be identified in the end-item maintenance sheets. Guidelines for the determination of repairable items are presented in AFSCM 65-2/AFLCM 65-3. For SRA, depot tooling, and test equipment functions, end-item maintenance sheets shall be completed. In preparing related RAS, the contractor is not required to complete the "Facility Requirements" column or the "Personnel and training equipment requirements" column, with the exception of the "Time required" subcolumn. Entries in

the "Time required" subcolumn shall be the time required on test equipment to fault isolate and verify repair.

(4) As depot tooling and test equipment is identified, end-item design sheets shall be prepared. In addition to the performance, design, and test requirements, each design sheet shall contain a list of the basic part numbers of all reparable items to be maintained by the recommended end item. Subsequent to review and approval of the end item, the contractor shall incorporate the design sheet in a Part I Detail Specification. Inventory equipment requirements shall be prepared for the depot tooling and test equipment items available in the DOD inventory and the SPO will determine availability of the items. CEI Identification Specifications shall be prepared for those items that are simple in function and design.

Block 64. Develop Detail Design Requirements for Maintenance Functions. The contractor shall develop design requirements for the detail maintenance functions using RAS as explained in block 33. The contractor shall revise previously established design requirements appearing on the RAS to assure that the most current preliminary design information has been recorded. For example, in the establishment of functions and design requirements for lower level items, it may be determined that a lower indenture item can perform the function previously allocated to a higher indenture item. Appropriate adjustment and changes shall be made to reflect engineering decisions of this type. Additional information shall be added to the RAS to define in detail previously determined design requirements.

Block 65. Develop Detail Design Requirements for Maintenance End Items.

a. The contractor shall identify changes to previously selected MGE and determine additional MGE and AAE required to satisfy the detail design requirements appearing on the RAS. This action is similar to that discussed in block 38. The difference is that the equipment being identified at this point is the MGE and AAE required in support of the MGE and AAE selected at block 38. Since the detailed definition represented by this block is con-

strained by the development of preliminary detail design information, it could not have been accomplished during the definition phase. Therefore, the indenturing to be accomplished represents contractually the detailing of existing requirements rather than the identification of new requirements. For example, the design and development contract will have previously scoped the effort required to define the new items identified. The design sheet shall be used to document engineering requirements for the additional CEIs. These design sheets become sections 3 and 4 of the Part I Detail Specifications to be placed on contract for the development of these additional CEIs. Where inventory equipment meets established requirements, the Inventory Equipment Requirement Specification shall be used.

b. Development of detail design requirements for MGE to support RPIE may be delayed until the conclusion of the competitive equipment procurement under the MCP. It is necessary for FSE and the construction agency to identify these requirements as early as possible in the construction cycle to insure availability of long-lead MGE at facility acceptance. The procedure used to identify MGE to support MGE shall be followed for identifying MGE to support RPIE. This will assure that MGE for RPIE is compatible with total system physical and support requirements, that it is not duplicating other MGE in the system; and that maintenance and calibration implications of the MGE are considered.

Block 66. Develop Detail Maintenance Requirements for Facilities.

a. Since preliminary design efforts will have established such specific equipment design parameters as tolerances, sizes, and power requirements, detail maintenance facility requirements can now be developed. The contractor shall determine required changes to previously defined facilities resulting from preliminary design changes to existing MGE and AAE and identification of additional MGE. The step is necessary to assure that previously selected facilities can still accommodate the equipment and that power, environmental, etc., interfaces have been considered. Changes in facility requirements

shall be made to RAS, facility interface sheets, design sheets, and facility perspectives as required by block 39.

b. At this point the total facility design will have progressed well toward completion, including those maintenance elements that are integral with operations facilities, such as work platforms in silos, organizational maintenance areas or shops, and utility services for portable MGE. It will, therefore, be necessary to evaluate proposed facility changes resulting from this detailing and to trade off the design impact of the change against the constraint of the existing facility design completion.

Block 67. Develop Detail Requirements for Maintenance Personnel and Training.

a. As a part of the detailed definition, the contractor shall determine the impact of preliminary design changes and additions to personnel and training requirements (see block 40). The basic tool to be employed shall be the RAS. As design requirements are changed, changes to personnel and training requirements shall be determined in terms of personnel tasks to be performed, performance times required, training equipment required, and changes to procedural data requirements. The initial QQPRI and TEPI shall be further detailed, if necessary, to reflect the results of additional preliminary design.

b. While the above actions (blocks 62-67) are shown as separate steps, they are accomplished on a concurrent basis. A continuous balance must be maintained between the requirements imposed by all elements of the system within the constraints of time, performance, and cost. When equipment requirements impose heavy demands upon personnel and training, an alternative equipment solution should be sought. When facilities constrain equipment design, alternative possibilities must be considered.

Block 68. Select Additional MGE, AAE, and Maintenance Facilities. The contractor shall select additional MGE, AAE, and maintenance facilities to complete the list of maintenance equipment required to support operations, maintenance, test, and activation functions. Normally, any new maintenance facilities identified will be depot-level maintenance or other special-

purpose maintenance facilities that can be designed and constructed independently from previously identified integrated operation and maintenance facilities. The equipment and facilities selected shall be recorded in the CEI list required in the System Specification. The requirement to develop additional equipment and facilities will be incorporated into the development contract.

Block 69. System Requirements Review. The SPO will review additional selection of maintenance elements resulting from blocks 62 through 67. The SPO will take action to contract for the development of these additional CEIs, using the Part I Detail Specifications. Where inventory equipment has been identified, the SPO shall determine the availability of the item. As described in chapter 4, this review is conducted to approve the establishment of any additional maintenance requirements, including facilities. System and CEI effectiveness requirements shall be updated by use of the data developed in blocks 62 through 67. The review to be made is similar to that described in block 43.

Block 70. Perform Maintenance Loading Trade-Off Studies.

a. The actions described in blocks 70, 71, and 72 are accomplished concurrently. The contractor shall perform the trade studies necessary to determine the combination of equipment, spares, and personnel required to effectively maintain the system.

b. In deriving information necessary to "maintenance load" the system, it will be necessary to conduct cost-effectiveness trade studies. Maintenance loading analysis provides an analytical means to determine the quantities of maintenance equipment, spares, and personnel and to examine plausible combinations in arriving at a best fit. Trade studies may be required to establish the basic ground rules necessary for conducting maintenance loading analysis. Examples of basic ground rules may be "Loading will be accomplished on a single failure basis." or "A CEI is in a maintenance mode from the point of malfunction indication until the unit returns to the supply bin."

10 March 1966

AFSCM 375-5

Block 71. Correlate MGE, Personnel, and Spares to Maintenance Functions.

a. Sufficient information should now be available to assess the impact that design has on the quantity of MGE, personnel, and spares required to maintain the system. The contractor shall assure that the design identified will result in attainable maintenance requirements: i.e., that the quantities of equipment and personnel required to maintain the system are not excessive.

b. To determine the impact of design on the quantity of equipment, personnel, and spares required to maintain the system, it is necessary to correlate the required MGE, personnel, and spares with the maintenance functions. The documentation to record these correlations is suggested in attachment 1.

c. Inputs to the maintenance loading analysis include information appearing on time-line sheets, end-item maintenance sheets, RASs, and Part I Detail Specifications. Other inputs necessary include information derived from the Maintenance Plan, System Specification, and other documents listed as source documentation (block 20). For example, such factors as the number of days deployed before units return for preventive maintenance, the number of units to be deployed concurrently, the hours of work per person, and equipment availability must be considered.

Block 72. Determine Total MGE and Maintenance Personnel Required by Location.

a. The correlation of MGE, personnel, and spares to maintenance functions, including the effect of queuing, permits the determination of the utilization frequencies of MGE by maintenance location and the quantity of MGE required to support a given force structure. A suggested way to document this data in summary form is described in attachment 1.

b. The contractor shall develop personnel and equipment utilization data to evaluate the impact of system design on maintenance requirements and to determine production requirement and training loads. For example, the personnel utilization data shall be used as a guide for structuring crews or teams when used with derived time-line data. The information pro-

vides the necessary data for evaluating the impact of design changes. For example, when the reliability of the system changes there will be an effect on the quantity of equipment and personnel required to maintain a constant in-commission rate.

Block 73. Revise Quantity Estimates of Equipment and Personnel. Utilizing the data derived from blocks 70, 71, and 72, the contractor shall revise the quantity estimates determined in blocks 53 and 54. Quantity and location information inputs shall be made to the system allocation document required by exhibit XI, AFSCM 375-1; the QQPRI document for quantities of personnel; and TEPI for training equipment requirements.

Block 74. System Requirements Review. The SPO will review the information acquired from the activities prescribed by blocks 70 through 73. The specific task will be to evaluate the impact of design on maintenance requirements determined as the result of the maintenance loading actions. Since considerable detailed information concerning equipment and personnel quantity requirements is now available, the effectiveness of the planned use of equipment personnel and facilities can be assessed. The maintenance loading analysis data will be reviewed, as well as the updated quantity estimates. As in the case of other SPO reviews, previous review actions will be followed up. This review action provides the basis for technical direction required.

Block 75. Continue Preparing Arrangement, Envelope, Construction, Plan, and Interface Control Drawings.

a. The detail design initiated at block 61 may require development of arrangement, envelope, construction, or plan drawings. Arrangement drawings show any projection or perspective of items with or without controlling dimensions to indicate their relationship. Envelope drawings show outline, overall and mounting dimensions, and other dimensions and data necessary to disclose mechanical, electrical, functional, and physical interchangeability of items. Construction drawings illustrate the design of buildings, structures, and related construction, individually or in groups, and include pertinent

services, equipment utilities, and any other engineering features required to establish the inter-related elements of the design. Construction drawings present design information by pictorial plans, elevations, sections, and details. Maps, perspectives, and site plans are not to be construed as construction drawings. Plan drawings depict foundation framing, floor, or roof plans. A plan drawing indicates the shapes, sizes, and materials of foundations, their relation to the superstructure, and their elevation with reference to a fixed datum plane, location of walls, partitions, bulkheads, structures, companionways, columns, stairs, ventilators, shape and size of roof, etc. These drawings shall be prepared in accordance with MIL-D-70327 and MIL-STD-7.

b. Construction and plan drawings are typical of those prepared in support of facility design for inclusion in Part II Detail Specifications, formerly called "Facility Construction Contract Plans and Specifications" (reference exhibit III, AFSCM 375-1), whereas arrangement- and envelope-type drawings are prepared in support of detail design of hardware. These drawings are representative of the type that are to be prepared to document the progress of the detail design between the PDR and critical design reviews (CDR). Applicable detail design drawings shall be available for use in CDRs. Some of these drawings will have been prepared in preliminary and sketch form during the latter part of the definition phase and prior to the PDR and are now made more definitive.

c. Sufficient detail design information such as schematic diagrams, is available to prepare interface control drawings, which are to be controlled as specified in AFSCM 375-1. Interface control drawings are used to define and portray physical interfaces between equipment being designed or procured by different contractors, to define interface design responsibilities within a contractor organization, and, in the case of facilities, to supplement the facility interface sheet. These drawings are actually prepared as interface responsibilities are defined. Some of these responsibilities may have been defined during the definition phase, particularly in the case of facility interfaces.

Interface control drawings shall be available for use in CDRs and become part of Part I Detail Specifications. Interface control drawings are not used for production.

Block 76. Continue Preparing Assembly, Installation, and Diagram Drawings.

a. With more detail design accomplished, detail drawings, such as assembly, installation, and diagram, shall be developed. Some of these drawings may have been prepared earlier and are not necessarily complete at this point. They form the basis for production drawings.

b. Assembly drawings depict the assembled relationship of two or more items or groups of items and assemblies, or a group of sub-assemblies required to make up an assembly.

c. An installation drawing shows general configuration, attaching hardware, and information to locate, position, and mount an item relative to fixed points and other items. An installation control drawing sets forth dimensional information, clearances, and cable attachments required to install an item to other items.

d. Diagram drawings are detailed schematics of electrical and electronic circuits and fluid mechanics piping/valving diagrams. These detail diagram drawings are to be derived from schematic diagrams and detail design. The detailed schematics shall indicate all interfaces, piping, valves, controls, wiring, terminal, relays, and other components comprising the CEI in their operating relationships. Circuits shall be depicted on an end-to-end basis. For example, one function of the launch control subsystem might be "transfer from ground power to aerospace vehicle power"; the detail schematic would indicate the circuit from the initiating control switch through all of the wiring internal to racks, consoles, and cables, through the aerospace vehicle wiring to the activating motor-driven switch/relay (which transfers the power) and back through the system to the indicator which shows that the function was performed. All wires, terminals, connector/conductor pins, relays, indicators, and/or switches used in this circuit would be included in the schematic.

e. These drawings are representative of the type that are prepared to document the prog-

ress of the detail design. Each system will dictate the type of detail drawings required. Applicable detail design drawings shall be available for use in CDRs. Engineering production drawings shall be prepared in accordance with MIL-D-70327 and the types of drawings shall be in conformance with MIL-STD-7.

Block 77. Conduct PDRs on Maintenance Equipment/Facilities.

a. In light of the design approach established during the PDRs on operations equipment and facilities, the contractor shall develop an engineering approach to the detail design of MGE, maintenance, test, and activation facilities and AAE. PDRs shall be conducted to review the design approach for maintenance equipment and facilities, as described in chapter 4 of this manual, and specified in exhibit XIV, AFSCM 375-1. The objectives of PDRs are to assure that (1) the design requirements baseline approved, established, and contracted against at the end of the definition phase can be achieved, (2) the engineering design approach taken by the contractor is technically feasible and sound, and (3) the detail design can commence to implement the design approach. Action items resulting from PDRs shall be covered contractually and binding upon PDR participants. Changes to the design requirements baseline established by the Part I Detail Specifications shall be made using design requirement ECPs in accordance with exhibit IX, AFSCM 375-1.

b. Changes to system engineering documentation shall be made to reflect changes to design and test requirements, design approach, functional requirements, facility requirements, training and training equipment requirements, personnel tasks, and procedural data requirements. Schedules for PDRs shall be established by the contractor subject to approval by the SPO.

c. For maintenance facilities, PDRs will establish that the maintenance facility requirements updated in blocks 62 through 73 are still compatible with facility design accomplished in blocks 58 and 61 or that design requirements ECPs have been initiated and approved to meet updated facility requirements. PDRs shall be

conducted as described in block 59 of new special maintenance facilities selected in block 68.

Block 78. Validate Maintenance Equipment/Facilities Part I Detail Specifications. The PDRs conducted on maintenance facilities will have determined that the design approach for these items is feasible and sound from a design, development, test, and activation view and that, therefore, the Part I Detail Specification is valid. Changes made to the contracted design/performance requirements during the PDR shall be reflected in Part I Detail Specifications using design requirements ECPs.

Block 79. Initiate Detail Design of Maintenance Equipment/Facilities. This action is similar to that specified in block 61, the items to be designed in detail are maintenance items; i.e., MGE, maintenance facilities, and AAE. As stated in block 65, explicit design or identification of MGE to support RPIE may be delayed until the RPIE to be maintained is specifically identified by the construction contractor.

Block 80. Continue Preparing Arrangement, Envelops, Construction, Plan, and Interface Control Drawings. This action is similar to that specified in block 75, except that the drawings describe the CEIs and facilities required for the maintenance of the system.

Block 81. Continue Preparing Assembly, Installation, and Diagram Drawings. This action is similar to that specified in block 76 with the exception that these detail drawings relate to the maintenance of the system.

Block 82. Expand Category I Test Requirements.

a. The following category I test program efforts have been completed:

(1) Category I test concept identified in PTDP was implemented on test functional diagrams and related RAS (reference blocks 3 and 4) which provided inputs to the category I test plan (reference AFR 80-14 and AFSCM 215-4).

(2) Category I system and subsystem test requirements were developed (reference blocks 10, 17, 31, and 51) and documented in the System Specification.

(3) CEI category I test requirements were developed on design sheets which became sections 3 and 4 of Part I Detail Specifications.

(4) Category I test sequences were developed using functional diagrams and time line sheets and documented in the category I test plan.

(5) Category I test equipment and facilities requirements were developed using schematic diagrams and design sheets (reference blocks 38, 41, 47, and 48).

(6) Category I test personnel requirements were developed using RAS (reference blocks 40 and 49).

b. Using the detail design developed, the contractor shall expand the test requirements identified earlier and outlined above. These test requirements shall be the only basis for the preparation of category I test procedures.

Block 83. Review Category I Test Procedures. Test procedures shall be reviewed on the basis of system engineering documentation, specifications, and detail design data. The reviews shall be selective and shall primarily concern the category I test procedures for the system and major subsystems and CEIs. This review shall assure that the category I test requirements can be effectively implemented.

Block 84. Support Category I Tests. Engineering support of category I test shall include (1) test result evaluation and (2) the identification and resolution of problem areas. Test result evaluation shall utilize the system engineering process, the System Specification, Part I Detail Specifications, and detail design data to assure that compliance with performance and design requirements has been successfully demonstrated. This process shall be applied in resolving technical problem areas arising from the test including definition and justification of required changes.

NOTE: Iterations of System Engineering Process During Detail Design. Figure 5 identifies iterations of the system engineering process during detail design. Since successive iterations or repetitions of the process will follow the same logic as the initial sequence of activities, each repetition resulting from the progression of detail design is not shown. It is not possible to predict the specific nature and depth of the iteration required for all systems. To portray all feedbacks and loops for every engineering decision is not practical. Consequently, a break

in the flow is shown to indicate that there is a continued requirement for repeating the process to reflect changes to engineering decisions as detail design progresses. Iterations will accommodate differences in time phasing of system elements; e.g., facilities will pace the elements they are supporting because of long construction lead times, and facility procurement under the MCP makes it necessary to perform final identification of facility CEIs late in the construction period.

Block 85. Prepare Calibration Requirements Summaries.

a. The SPO may elect to prepare calibration requirements summaries (CRSs) utilizing in-house Air Force resources or may direct them to be prepared by the contractor. When directed contractually, the contractor shall prepare CRSs for evaluating existing or establishing new calibration, certification, and measuring standards for AVE, OGE, MGE, AAE, and facility equipment at organization, field, and depot levels of maintenance. The data in Part I Detail Specifications and RAS provide the input/output parameters requiring calibration, certification, and measuring. The FSE will identify calibration requirements for critical RPIE subsystems. If the equipment requiring calibration is to be procured by competitive bidding under the MCP, identification of specific parameter values may be delayed until selection of specific equipment during construction. In this case, the CRS will be completed by subsequent iteration.

b. Calibration, certification, and measuring requirements shall be determined during the system engineering process. A CRS should be developed and produced in two phases. The contractor's obligations for both phases should be covered in one contract.

(1) The first phase would cover the calibration requirements from the start of CEI determination through category II testing. These calibration requirements would be consolidated by the contractor and are those which are to be complied with by contractors.

(2) The second phase would cover the calibration requirements determined during category II testing and through the operational phase. These calibration requirements would

be consolidated by the contractor with assistance from the SPO and the using command, and are those which are to be complied with by AF operations and maintenance personnel. Phase II calibration requirements would reflect the experiences gained during the early portion of the operational phase.

c. The calibrations workload and out-of-commission time are significant factors that must be reviewed during the detail design process to assure that the total system can be efficiently maintained. The end-item maintenance sheets shall be examined to establish an estimate of time, manpower, skills, and equipment required for calibration.

d. The CRS shall provide a 4-part summary outlining the design requirements for measurement of parameters at each echelon of measurement. The summary provides for displaying the parameters of each item of the system to be measured or calibrated. The CRS shall indicate the ranges and accuracies of the parameters to be measured by each specific device comprising the chain of equipment from the operations requirement to the base standards laboratory. CRSs shall summarize test equipment requirements in both kind and quantity and thereby assure that all parameters to be measured are considered and satisfied and that the potential workload of a base precision measurement equipment laboratory (PMEL) can be appraised.

e. It is not intended to provide calibration capability at local base PMEL level to calibrate all working standards. Where it is not economical to provide this capability, the items will be exchanged. If the working standards are the property of the squadron (category III), the base PMEL (category IV) will be responsible to have a calibrated exchange item on hand at the correct time for exchange. Examples of such items are dead-weight testers and standard cells.

f. Summaries for more than one type of equipment or parameters may be contained on one page. Similar types of parameters (category I) should be grouped on successive pages; however, it is not desired that data be held until a large number of similar summaries can be accumulated. Data provided by subcontractors

or associate contractors shall be segregated in separate sections of the CRS.

g. The calibration requirements information shall be prepared in the format specified in attachment 1. The CRSs shall be revised when corrections or revisions to the Detail Specifications or other detail design engineering documentation reflect a design change in parametric values or means of measurement.

h. Calibration requirements developed for the purpose of controlling the accuracy of the contractors' measuring and test equipment shall be developed in accordance with MIL-C-45662A and MIL-Q-9858A. Unless otherwise specified, CRSs shall be initiated at this point and submitted to the SPO after the CDRs.

Block 86. Prepare Part II Detail Specifications.

The contractor shall prepare Part II Detail Specifications for equipment and facilities. Part II Detail Specifications shall contain reference to an approved top drawing for the CEI and shall be prepared in accordance with exhibits II, III, IV, and VI, AFSCM 375-1. This block does not represent the initiation of engineering and detail design required to formulate the Part II Detail Specification, but it does represent the start of formal documentation of the engineering and detail design. The translation of design into hardware must be constantly assessed within the design requirements and design approach established by Part I Detail Specifications. Emphasis on the "build to" documentation (i.e., Part II Detail Specification) is necessary to assure that the delivered product matches the requirements against which the product is to be delivered and accepted.

Block 87. Determine AVE, OGE, AAE, and MGE Quantities Required.

a. System engineering documentation establishes and maintains continuity between engineering and provisioning. The contractor, with approval from the SPO and SSM, shall establish final firm quantity requirements for AVE, OGE, MGE, and AAE. The contractor shall base CEI quantity determination on the system engineering documentation and quantity estimates made earlier. The required CEIs for test, activation, and the operational inventory shall be procured against Part II Detail Speci-

fications in sufficient time to insure availability when needed.

b. MGE quantity requirements for test, activation, and the operational inventory shall be determined as described in AFPI 71-650. The establishment of firm quantities of MGE shall be based on the system engineering documentation, particularly end-item maintenance sheets.

Block 88. Provide Engineering Inputs to the Selection and Acquisition of Spare Parts.

a. The purpose of this action is to provide engineering inputs to the selection and acquisition of the quantities of spares required to support I&C and category II tests. In order to assure that spares selection is compatible with the requirements of the system, the results of the system engineering effort shall be used as the foundation for the selection and identification of spares quantities required. Major inputs to this action shall be the data provided on the maintenance loading sheets. This latter information shall form the basis for spares provisioning action for the operational inventory as required later in the program by AFPI 71-673.

b. Operational program spare parts for AVE, OGE, MGE, and AAE shall be selected and acquired as set forth in AFPI 71-673. The system engineering documentation establishing the detail maintenance requirements shall be used as the basic source of information in selecting spare parts. Spares shall be selected on an incremental basis as the required information becomes available.

c. Spares for RPIE will be provisioned as outlined in AFR 400-41. FSE shall assure that adequate, realistic recommended spare parts lists are developed from maintenance concept, facility Detail Specifications, vendor data, and maintenance data for delivery as required by AFR 400-41. The selection of RPIE spares may be delayed until the award of facility construction contracts (block 94) and the subsequent updating and expansion of detail facility engineering and support data.

Block 89. Define Acceptance Test/Verification Requirements.

a. Acceptance testing, I&C, and category II testing have similarities of purpose and phasing in system acquisition. In order to avoid un-

necessary test duplication and to permit the selection of optimum test requirements in view of the total planned test program, the definition of all test requirements shall be coordinated as one action. In defining test requirements, emphasis shall be directed toward assuring that (1) major CEIs and subsystem functional interfaces are verified; (2) operations equipment and MGE, rather than special equipment exclusively for I&C or testing, are used to the maximum extent possible; (3) the I&C requirements which are an integral part of testing approximate the operations environment; and (4) the system is operable and maintainable in the operations environment.

b. CEI acceptance test verification requirements shall be developed by the contractor for inclusion in section 4 of Part II Detail Specifications. The test/verification requirements shall be limited to those necessary to demonstrate compliance with the section 3 requirements. The contractor shall define detail test functions and test equipment, personnel, and facilities necessary to implement the acceptance test/verification requirements.

c. Acceptance tests of a CEI may be made on an incremental basis: i.e., testing of a sub-assembly may be required prior to its incorporation into the next higher assembly. Acceptance testing may or may not be concurrent with category I and category II testing.

Block 90. Define Installation and Checkout Requirements. The general requirements for I&C of the system contained in the System Specification shall be amplified and made more definitive. The appropriate activation functional diagrams, RAS, time lines, schematic diagrams, and Part II Detail Specifications shall be expanded or initiated to assure identification of the functional requirements and the attendant equipment, personnel, and facility requirements. Activation functions may include (1) equipment handling, storage, and installation at the use site and (2) equipment post-installation verification tests.

Block 91. Expand Category II Test Requirements.

a. Category II test program requirements shall be further defined by the contractor to (1)

expand the previously developed category II test requirements in the System Specification; (2) expand and integrate the CEI test requirements deferred to category II testing by the Part I Detail Specifications; (3) define the specific category II test functional requirements and related test equipment, facilities, and personnel requirements. Since this effort will include formal demonstration tests preparatory to turnover of the system to the using agency, it necessitates developing test requirements which make maximum use of using agency operations and maintenance personnel and of final operations and maintenance procedural data. For definitions and objectives of category II test, refer to AFR 80-14.

b. Category II tests assure that the system, subsystem, and CEI qualification testing has been satisfactorily completed and that minimum acceptable reliability, maintainability, safety, and other system effectiveness requirements have been successfully demonstrated prior to the turnover to the using agency.

c. The resulting acceptance test, I&C, and category II test requirements and the test requirement/facility detail design data shall be utilized for the preparation of detailed test procedures, I&C procedures, and the using agency turnover plan.

Block 92.—Conduct Critical Design Review (CDR) on Operations and Maintenance Equipment/Facilities.

a. The contractor shall conduct CDR on the operations and maintenance equipment/facilities. CDRs may or may not be attended by the SPO or the designated development engineering representative depending on the results of PDRs, the detail design efforts, and the complexity of the CEI. The schedule of CDRs shall be established by the contractor subject to approval by the SPO. CDRs for facilities will consist of the traditional final design review of the facility detail design and will be conducted by the appropriate AFSC division civil engineering activity. This review will result in completion of part II of the Facility CEI Specifications (block 93) and their issue as "bid packages" to the appropriate construction agency.

b. These reviews are conducted on an incremental basis to insure acceptability of the detail design accomplished since the PDRs. The detail design presented on drawings, schematics, and mockups or actual hardware shall be reviewed against the design requirements and design approach in the Part I Detail Specification. The objective is to determine whether the recommended detail design solution satisfies the design requirements and basic approach established by Part I Detail Specifications. The material reviewed at a CDR will vary depending upon the complexity of the CEI. In some cases, a review of the drawings provided with the initial Part II Detail Specification will suffice; in other cases, the contractor may be required to present soft or hard mockups, breadboards, or prototype hardware to establish that an adequate detail design solution is provided. CDRs are intended to include inspection of all aspects of the design such as performance, packaging, structure, effectiveness factors, and safety.

c. Each CDR shall be an integrated review by all design engineering areas and technical disciplines having an input to the CEI being reviewed. Separate formal design reviews shall not be conducted to determine the adequacy of a single particular design engineering area or technical discipline: e.g., mechanical, electrical, or maintainability and safety. Detailed procedures for CDRs are specified in exhibit XIV, AFSCM 375-1. The relationship to other reviews is specified in chapter 4 above. CDR action items shall be covered contractually and will be binding on CDR participants. Changes resulting from the CDR shall be incorporated in the system engineering documentation and appropriate Detail Specification.

d. For other than facilities, the result of a successful CDR is to commit design to production: i.e., the contractor is permitted to produce equipment in accordance with the detail design presented at the CDR and reflected in Part II Detail Specifications.

NOTE: *Continue System Engineering Process During Production.* A break is shown in figure 5 to indicate that there is a requirement to continue the system engineering process dur-

ing the production effort. As the design and development effort is completed and the production effort is expanded, the updating of and changes to system engineering documentation are reduced until it becomes primarily a change evaluation and justification tool for ECP actions. At the start of production, the SPO will determine when updating and changes to system engineering documentation will be terminated and will identify the level of effort required until that time.

Block 93. Complete Part II Detail Specifications.

a. The contractor shall complete Part II Detail Specifications prior to the first article configuration inspections (FACI). The Part II Detail Specifications and referenced drawings are the complete "build to" documentation necessary for the control, logistic support, and reprocurement of the CEIs. These specifications represent the product of the detail design effort and define the product configuration baseline (reference AFSCMs 375-1 and 375-4).

b. Part II Detail Specifications for facilities will be arranged in appropriate packages for construction bidding and contract award as provided for in the MCP. All documentation, drawings, design calculations, procurement specifications, control estimate, special conditions, etc., necessary for the execution and management of construction traditionally included within the Facility Construction Contract Plans and Specifications will make up part II of the Facility CEI Detail Specifications required by exhibit III, AFSCM 375-1. For critical RPIE subsystems, Part II Detail Specifications shall be completed in accordance with exhibit II, AFSCM 375-1.

Block 94. Inputs to Production and Facility Construction Contract.

a. With the confirmation by DOD/USAF of word to proceed with production and the number of units to be produced having been specified in the production schedule, contracts for production quantities are awarded. These contracts for hardware are negotiated against the Part II Detail Specifications.

b. The actual acquisition of a facility, which is comparable to the production cycle of other system elements, is normally funded and con-

tracted for separately through the MCP. The award of the construction contract is significant in its phasing to other system elements, particularly since it signifies the start of a further identification cycle for system equipment through competitive procurement of commercial standard and "off-the-shelf" hardware. This late phasing of detailed information places a requirement on FSE to provide the best compromise between total system needs and the military construction environment by effectively planning and forecasting the data availability and establishing the submission schedules. In order to meet these requirements, FSE must be fully aware of the needs of the total system engineering process during the acquisition phase. With the award of construction contract, FSE changes from a role of essentially system design to one of primarily monitoring the construction and of updating the support data.

Block 95. Review Acceptance Test/Verification Procedures. The acceptance test verification procedures developed to implement the test requirements defined in block 89 shall be reviewed for compatibility with the test requirements in the System Specification, the Part I Detail Specification, and the system engineering documentation. Selective review of acceptance test procedures shall be accomplished for major subsystems and CEIs. Qualification testing should be completed prior to the start of acceptance testing. When qualification tests are not complete, acceptance testing shall be accomplished on a contract deviation basis.

Block 96. Conduct First Article Configuration Inspections (FACI) on Operations and Maintenance Equipment/Facilities.

a. This action results in the approval of the product configuration baseline and completes the transition of control from "design to" to "build to" documentation. The requirements for FACIs are specified in exhibit XIV, AFSCM 375-1. FACIs compare the detail drawings and specification with the hardware produced from these drawings and specifications. The product of a FACI is formal acceptance of the Part II Detail Specifications and is a prerequisite to CEI acceptance test/verification. Subsequent to a successful FACI,

changes to the Part II Detail Specifications shall be made by means of preliminary and formal ECPs in accordance with exhibit IX. AFSCM 375-1.

b. There will be FACIs for facility CEIs described by Part II Detail Specifications developed under exhibit II. AFSCM 375-1. There is no FACI required for facility CEIs defined under exhibit III. AFSCM 375-1. The equivalent to a FACI for these CEIs is a series of reviews and events during construction and activation. For example, the submission and approval of shop drawings, fabrication drawings, material samples, etc., documents the detail design or equipment selection by the construction contractor. Once approved, these data further define the product configuration baseline. Individual equipment and materials are subject to inspection by the construction agency to insure its compliance with Part II Detail Specification requirements. These inspections may take place at the supplier's facility or at the construction site during installation. Completed facility elements must be inspected for compliance and "as built" drawings must be prepared to document field changes and options exercised by the construction contractor in the actual physical construction and arrangement of equipment. Where performance is specified, acceptance testing will be accomplished and documented prior to the acceptance of the facility from the construction contractor and transfer of accountability by means of DD Form 1354, "Transfer and acceptance of military real property" (reference AFR 88-9). Through this process, the shop drawings, vendor data, and "as built" drawings all become part of the specification package.

c. Because of these differences, it is essential that the AFSC division civil engineering activity establish the proper controls during construction to insure the timely availability of the specification package and that the data be responsive to the needs of the system engineering process as well as the facility construction process.

d. Where communications electronics facility installations are involved, the equivalent to FACI is an inspection which results in the execution of an AFTO Form 88, "Communications-

electronics-meteorological installation inspection certificate," reference T.O. 31-1-8. This inspection shall insure demonstration of the technical adequacy of newly installed, modified, or modernized ground communications-electronics systems.

Block 97. Review Installation and Checkout Procedures. The contractor shall review I&C procedures using system engineering documentation, the System Specification, the Part II Detail Specifications, Inventory Specifications, and related detail design data. The review shall be selective and shall primarily be accomplished on the system and major subsystem checkout procedures and on any critical installation procedures. The reviews shall be directed toward assuring that equipment I&C requirements are properly implemented by the I&C procedures.

Block 98. Review Category II Test Procedures. Category II test procedures shall be reviewed for compatibility with category II system and major subsystem test requirements. This review shall be directed toward assuring that the selected test procedures specified or referenced in the system test plan have been properly considered and will fulfill the appropriate category II test requirements (reference block 89).

Block 99. Support I&C and Category II Tests.

a. System engineering support of the I&C shall be provided for the purpose of (1) facilitating the resolution of technical problem areas; (2) supporting any resulting change definition and justification; (3) supporting any required retest during the I&C operations, and (4) failure analysis.

b. Category II test support shall include (1) test result evaluation to assure that performance and design requirement compliance has been demonstrated; and (2) identification and resolution of problem areas including changes.

Block 100. Conduct Technical Approval Demonstration. There is a requirement to conduct technical approval demonstrations as part of the turnover of the system to the using command (reference AFR 80-28). These demonstrations will be conducted on major systems for the purpose of demonstrating accepting the complete

system in the operational environment. System engineering shall support technical approval demonstrations to be conducted against requirements in the System Specification. The requirements for technical approval demonstrations shall include using command turnover requirements and acceptance requirements that can be demonstrated only in a system-installed operational environment. Required schedules and procedures will be established by the SPO.

Block 101. Assist in Definition of Category III Test Requirements. System engineering support in defining category III test requirements shall be provided by the contractor when directed by the SPO (reference AFR 80-14). Category III test objectives include assessment of system operational capabilities and evaluation of the logistic system, personnel, and procedural data. System-oriented functional diagrams, RAS, time-line sheets, System Specification, and related design data shall be used to identify (1) system requirements data and (2) backup engineering rationale required to define category III test requirements. Although the using command or agency will be responsible for the development of category III test requirements, specific system engineering inputs should be made to insure using command/agency cognizance of the category I, I&C, and category II testing previously accomplished.

5.0 OPERATIONAL PHASE REQUIREMENTS:

Block 102. Review Category III Test Procedures and Support Tests. Review of category III test procedures and the support of category III tests shall be provided by the contractor when directed by the SPO. Test support shall include necessary indoctrination of using command/agency personnel in the system characteristics and mode of operation, selective technical review of the category III test procedures, and assisting in technical evaluation of the test results and failure reports.

Block 103. Develop Follow-On System Modifications.

a. The system engineering process and related data shall be utilized in performing feasi-

bility studies to define and justify major system modifications required as a result of product improvement changes or changes to operational requirements when (1) the AFSC has engineering responsibilities for the system or (2) the AFLC has engineering responsibility but requests technical support from the AFSC. Such modifications are identified as class IV and class V modifications in AFR 57-4.

b. System engineering support of such modifications is identical to support of previous changes (i.e., the system engineering process and the modification of existing and or development of new functional diagrams, RAS, time-line sheets, etc., shall be accomplished to fully define and justify the change). Particular emphasis shall be placed on determining and defining the total system impact of the change; i.e., defining equipment, personnel, facility, and procedural data impacts for affected operations, maintenance, activation, and test functions.

Block 104. Define Follow-On Development Test Requirements. The system engineering process and related data shall be used to define the development test requirements for follow-on system modifications. Such testing may be necessary because of (1) significant changes in system capability or changes in system application that were not tested during category I and II tests and are not part of an overall series change or (2) changes to correct system deficiencies for which test articles were not available during category I and II tests.

Block 105. Review Follow-On Development Test Procedures and Support Tests. Review of follow-on developmental test procedures and test support shall be similar to that accomplished for category II testing (reference blocks 98 and 99).

Block 106. Update System Specification and Part II Detail Specifications. Changes to system performance design requirements or CEI product configuration requirements resulting from testing or system modification shall be reflected in updated specifications in accordance with exhibits VIII and IX, AFSCM 375-1.

Exhibit 2

IMPLEMENTATION REQUIREMENTS

1.0 PURPOSE AND SCOPE. This exhibit presents minimum requirements for implementing AFSCM 375-5. These requirements shall be complied with by the SPO, other Air Force organizations, and contractors involved in the specific system or project.

2.0 GENERAL. As required in paragraph 10, chapter 4, the SPO will assure that the requirements of exhibits 1 and 2 and attachment 1 are specified in the system engineering implementation plan (SEIP, reference para. 5.0), and that the contractor responsibilities described in paragraphs 3.0 through 6.0 are contractually applied to all contractors participating in system programs or projects for which the definition or acquisition phase is applicable. The applicable task describing the required system engineering effort shall be established by the deputy director for engineering and included in the work statements. The SPO will assure that an SEIP is prepared to implement the requirements and objectives of this manual in the most effective manner. Specific consideration will be given to applying selected requirements of this manual to system programs or projects for which a definition or acquisition phase in accordance with AFR 375-1 is not specifically directed when the program would benefit from such application (reference para. 11.0). The SPO will establish memoranda of agreement defining the responsibilities of participating Air Force organizations involved in system engineering the specific system or project. These agreements will include:

- a. Definition of the specific areas of responsibility. For example, the participating AFSCM organization will support the SPO in monitoring and evaluating the contractor's system engineering functions, actions, and results.
- b. Definition of intrasystem and intersystem interface responsibilities.

c. Definition of communication channels between the participating Air Force organizations and the SPO, and between Air Force organizations and participating contractors.

d. Interpretation of Air Force regulations necessary for the successful accomplishment of the requirements of the manual.

3.0 GSE/TDC OR SEG/R&T RESPONSIBILITIES. General system engineering and technical direction shall be accomplished by SEG/R&T or GSE/TDC to assure that overall system technical objectives are being met in an economical and timely manner. In general, the tasks for which the SEG/R&T or GSE/TDC shall be responsible include (1) analysis of basic system requirements and formulation of the initial system performance/design requirements specification, (2) system design verification, (3) evaluation of technical adequacy of system, subsystem and equipment interfaces, (4) system, subsystem, and equipment design and performance integration, (5) analysis and evaluation of system, subsystem and equipment development and test, and (6) technical direction associated with system, subsystem and equipment engineering integration. GSE/TDC or SEG/R&T shall support the SPO in accomplishing the activities described in exhibit I or which the SPO has primary responsibility. Definitive levels of effort required by the SEG/R&T or GSE/TDC to implement these technical tasks should be negotiated and established in a memorandum of agreement. Specific responsibilities for each program phase are included in the following subparagraphs.

3.1 Conceptual Phase (Conceptual Transition). SEG/R&T or GSE/TDC responsibility shall be established at the time the SPO cadre is established. During this phase, the general system engineering and technical direction tasks are directed toward meeting the prerequi-

sites for definition phase described in AFSCM 375-4. This effort shall include supporting the SPO to:

a. Expand the requirements contained in the SOR/OSR/ADO and evolve technical concepts and definitize requirements to a level which will provide a basis for definition phase. Specific system engineering actions during conceptual transition include establishment of mission requirements; derivation of general system requirements, including consideration of facilities, test, and activation development, personnel requirements, and maintenance; initial synthesis of requirements into hardware terms and, as applicable, computer program terms; trade studies; identification of major technical risks; and preparation of technical inputs to the PTDP, including "design to" criteria, overall reliability, survivability/vulnerability, maintainability and safety parameters. The result of this effort by the SEG/R&T or GSE/TDC will be initial system engineering documentation: namely, functional diagrams, RASs, trade study reports, time lines, and schematic diagrams.

b. Formulate, review, and approve the plans and tasks which will be used to implement and control the system engineering effort during the definition and acquisition phases. The SEG/R&T or GSE/TDC will be responsible for preparation of the SEIP to implement the requirements and objectives of this manual. This plan will be prepared in accordance with paragraph 8.0.

c. When contracted studies are required, provide surveillance and review of contractor efforts. Where evaluation indicates a new or changed requirement, initiate technical guidance or direction.

3.2 Phase IA. The SEG/R&T or GSE/TDC shall support the SPO to:

a. Prepare the basic system engineering documentation required by this manual to develop technical inputs to the initial System Performance/Design Requirements General Specification (System Specification).

b. Prepare the technical portions of the initial System Specification required by AFSCM 375-4 and defined in exhibit I, AFSCM 375-1,

in accordance with the procedures specified in exhibit I, AFSCM 375-5.

c. Provide technical inputs to the request for proposal (RFP), including statements of work.

d. Provide clarification of the technical portions of the RFP as required. No contractor direction will be given during proposal preparation.

e. Prepare criteria for and evaluate the technical content of each proposal in support of the source selection board. Assist the source selection board as appropriate.

f. Revise the definition phase statements of work in preparation for phase IB negotiation.

3.3 Phase IB. The SEG/R&T or GSE/TDC shall review, evaluate, advise the SPO on, and initiate technical direction as required to obtain maximum results from the contractor's phase IB report. During conduct of phase IB, the SEG/R&T or GSE/TDC shall inform the SPO if a contractor's approach is not compatible with the requirements in the System Specification. SEG/R&T or GSE/TDC actions during the contractor's definition process shall include technical evaluation of (1) incrementally developed system engineering documentation from all technical aspects: i.e., hardware, personnel, facilities, and procedural data; (2) contractor's expansion, revision of the System Specification; (3) contractor-developed Part I Detail Specifications; and (4) CEIs which involve development of the state-of-the-art, high technical risk, or high acquisition costs. To accomplish the objectives established above, the SEG/R&T or GSE/TDC shall support the SPO to:

a. Provide technical clarification and interpretation of system engineering documentation and specifications to all contractors at the guidance meeting.

b. Schedule and accomplish in-process reviews and technical interchange meetings as necessary on system requirements and system design. These reviews and interchange meetings are specified in paragraph 11, chapter 4. The SEG/R&T or GSE/TDC participation shall include selective technical evaluation of the products of the system engineering process and shall compare the technical evolution of the system with program objectives and total re-

quirements. Based upon this evaluation and comparison, the SEG/R&T or GSE/TDC shall make appropriate recommendations to the SPO.

c. Initiate technical direction as required to assure that the definition phase technical objectives are obtained. Technical direction may result from evaluation of the results of a SE TD review or technical interchange meeting, or from a request by the SPO.

d. Prepare criteria for evaluating the technical content of the contractor's phase IB final report.

e. Resolve technical interface problems, including those which develop between contractors.

3.4 Phase IC. The SEG/R&T or GSE/TDC shall evaluate the technical content of the contractor's phase IB final report. The SEG/R&T or GSE/TDC shall support the SPO to:

a. Perform technical selection of the most promising design approach and of the related system/subsystem elements from each proposal. When required, synthesize these elements justifying selection of proprietary items into a system which best meets program requirements.

b. Revise the system engineering documentation and system effectiveness models and originate new system engineering documentation and system effectiveness models as appropriate to accomplish the evaluation effort and to define an optimized system configuration. Documentation generation or revision will be to the extent required to define system requirements in a manner to permit negotiations of fixed-price, fixed-price-incentive, or cost-plus-incentive contracts for phase II development effort.

c. Update the System Specification and Part I Detail Specifications as required and prepare inputs to the PSPP and technical portions of the phase II statements of work.

d. Make technical recommendations to the SPO relative to the contractor's continuing engineering and development in required areas during phase IC.

e. Provide technical guidance to contractors on their assigned tasks as required. Technically support the source selection board.

f. Provide technical assistance during the phase II definitive contract negotiations.

3.5 Acquisition Phase (Phase II Development).

SEG/R&T or GSE/TDC during phase II will include system/subsystem design and support the SPO deputy director for test and deployment to accomplish test evaluation covered by the System Specification and the Detail Specifications. Since a significant part of general system engineering occurs during the system formulation effort in conceptual-transition and phases IA and IB, technical direction required in regard to resolution of system problems during hardware development in phase II should be minimized. Only in the instance where a major technical question arises from data review, test results, or other stimulus shall technical direction be used. The SEG/R&T or GSE/TDC shall assure that system engineering and technical direction efforts shall be applied to (1) system subsystem design verification and control, (2) evaluation of technical adequacy of system and subsystem performance in view of test results, and (3) assuring that the phase II designs are in fact evolving into an effective system reflecting a practical combination of equipment, facilities, personnel, and procedural data. The SEG/R&T or GSE/TDC shall support the SPO to:

a. Participate in design reviews, acceptance tests, FACI, and technical approval demonstrations as specified in paragraph 12, chapter 4. As appropriate, the SEG/R&T or GSE/TDC shall make recommendations to the SPO and initiate technical direction.

b. Selectively perform technical evaluation and recommend approval of or changes to submitted products of the system engineering process.

4.0 AFPRO RESPONSIBILITIES. The AFPRO development engineering office and production division will provide engineering support to the SPO in accordance with the following subparagraphs:

4.1 AFPRO Development Engineering. The development engineering office at each AFPRO is responsible for support to the SPO under Memoranda of Agreement and as stated in AFSCR 23-39 and AFSCM 375-6. This support is in the area of resident surveillance of the contractor's design, development, and engineering effort. The objective is to provide engineer-

ing support to the SPO and to reduce total decision-making time through in-plant engineering evaluation and management surveillance.

4.1.1 The areas in which development engineering can evaluate and monitor the contractor's activities to provide SPO support are:

- a. Engineering management, including such areas as planning, scheduling, allocation of manpower, and budget control.
- b. Reliability program.
- c. Engineering studies, proposals, and design approaches.
- d. Test plans, test directives, and test activities.
- e. Configuration management.
- f. Engineering changes.
- g. Engineering data control and technical publications.
- h. Value engineering program.
- i. Engineering subcontracting practices.

4.2 AFPRO Production Engineering. The production division of the AFPRO or other contract administration organization is responsible for support to the SPO in surveillance of the contractor's integration of systems engineering with production requirements. The objective is to provide production engineering support to insure producibility and the integrity of development/production schedules and cost.

4.2.1 The production division will evaluate and monitor contractors' actions during all phases in such areas as:

- a. Planning and scheduling of design release to production.
- b. Producibility and manufacturing methods.
- c. Value engineering.

5.0 PARTICIPATING CONTRACTOR RESPONSIBILITIES. Participating contractors shall be responsible for accomplishing the contractor actions described in exhibit 1 for the portion of the system covered in their contracts. Definitive levels of effort required by the participating contractors to comply with the following subparagraphs shall be included in work statements.

5.1 Phase IA. Since phase IA is an unfunded effort, the following efforts are suggested:

a. Prepare and use system engineering documentation as necessary to formulate the technical portion of the phase IB proposal and phase II specimen proposal. This should include expansion of the initial System Specification, expansion of the system engineering documentation provided in the RFP, and the performance of trade-off studies as necessary to identify overall requirements for equipment, facilities, and personnel.

b. Prepare detail phase IB and phase II milestone schedules for inclusion in the phase IB proposal and phase II planning proposal. These schedules should be prepared within the framework of the SEIP to include recommended dates for system engineering process evaluation, documentation review, and input requirements from other participating agencies.

5.2 Phase IB:

a. Prepare, maintain, and use required system engineering documentation to formulate the technical portion of the contractor phase IB final report and to provide a basis for specification preparation, system element identification and quantity determination, test planning, and change evaluation. This shall include systematic definition of requirements for operations, maintenance, test and activation equipment, facilities, personnel, and procedural data; performance of necessary preliminary design as required to accomplish this definition; updating of the initial System Specification; and preparation of Part I Detail Specifications.

b. Prepare definitive phase II milestone schedules within the framework of the SEIP, including dates for system engineering process evaluation, system engineering documentation review, and submittal dates for input requirements from other participating agencies; tentative PDR, CDR, FACI, test and technical approval demonstration scheduling; and tentative hardware drawing release schedules.

c. Submit input data to the integrating assembly contractor (IAC) or prime contractor (PC) as required for system level integration (applicable only when an IAC or PC is participating).

d. Review the technical content of system engineering documentation prepared by other contractors which affects their area of responsibility and effect required action.

e. Conduct required reviews and participate in technical interchange, technical direction, and integration meetings. Submit copies of the minutes of the reviews and meetings to the SPO for review and any required action.

5.3 Phase IC:

a. Provide technical clarification of the phase IB final report including phase II firm proposal upon request.

b. Accomplish additional system engineering as specified by the SPO during the "holding period."

5.4 Acquisition Phase (Phase II Development):

a. Accomplish system segment preliminary and detail design, production, test, acceptance, training, installation and checkout, and other activities necessary to effect system segment acquisition.

b. Prepare, maintain, and use required system engineering documentation as necessary to provide a basis for accomplishing paragraph a, above.

c. Submit input data to the IAC or PC as required for system level integration.

d. Review the technical content of system engineering and other documentation prepared by other contractors which affects their area of responsibility and effect required action.

e. Schedule and conduct required preliminary and critical design reviews as specified in paragraph 12, chapter 4, and participate in technical interchange, technical direction, and integration meetings.

6.0 INTEGRATING ASSEMBLY OR PRIME CONTRACTOR RESPONSIBILITIES. The IAC or PC shall accomplish the contractor activities described in exhibit I to assure detailed definition, integration, and satisfaction of the system requirements. Definitive levels of effort, required by the IAC or PC to comply with the following subparagraphs, shall be included in their work statements:

6.1 Phase IA. Since phase IA is an unfunded effort, the responsibilities listed below are suggested:

a. Take the same actions as are stated for a participating contractor for the portions of the system covered in the IAC's or PC's RFP.

b. Make and document system-level studies as required to interpret, develop, or expand overall system requirements.

c. Prepare, maintain, and use integrated system engineering documentation.

6.2 Phase IB:

a. Assume the same responsibilities as are stated for a participating contractor for the portions of the system covered in the IAC's or PC's contract.

b. Make and document system-level studies as required to interpret, develop, or expand overall system requirements.

c. Review the system engineering documentation prepared by the participating contractors for compliance with overall system requirements and technical adequacy.

d. Prepare, maintain, and use integrated system engineering documentation.

e. Convene and conduct integration meetings as necessary to accomplish timely integration of participating contractor inputs.

6.3 Phase IC:

a. Provide technical clarification of the phase IB final report including phase II firm proposal upon request.

b. Accomplish additional system engineering as specified by the SPO during the "holding period."

6.4 Acquisition Phase (Phase II Development). Assume the same responsibilities as are stated for a participating contractor for the portions of the system covered in the IAC's or PC's contract.

a. Make and document system-level studies as required to interpret, develop, expand, or synthesize overall system requirements and preliminary detailed design solutions.

b. Accomplish system preliminary and detail design, production, test, acceptance, training, installation and checkout, and other actions necessary for system acquisition. Maintenance of the integrated system engineering documentation shall include acting as lead contractor to implement the SPO and GSE/TDC or SEG/R&T comments or approval conditions.

c. Expand, maintain, distribute, and use integrated system engineering documentation as required to provide a basis for system synthesis.

d. Convene and conduct integration meetings as necessary for timely integration of participating contractor inputs. Record and distribute minutes of these meetings.

7.0 INTEGRATION OF REQUIREMENT DOCUMENTATION. The SPO will take specific steps for review of proposed contractor work statements to insure well-defined contractual and technical interfaces between the requirements of this manual and the requirements of related military specifications, including bulletins, exhibits, and standards that are not wholly included in this manual: e.g., reliability requirements of MIL-R-27542; maintainability requirements of MIL-M-26512; safety requirements of MIL-S-38130; personnel requirements of MIL-D-26239; cockpit design requirements of MIL-P-25996; and human engineering requirements of MIL-H-27894.

8.0 SYSTEM ENGINEERING IMPLEMENTATION PLAN. A detail SEIP shall be prepared by the GSE/TDC or SEG/R&T for inclusion in section 17, "definition plan," of the PTDP for the definition phase, and as section 17 of the PSPP for the acquisition phase. The SEIP shall identify:

a. AFSCM 375-5 requirements that are applicable to the system or project which will result in the most effective system engineering shall include (1) identification of specific SEG/R&T or GSE/TDC and contractors' responsibilities (reference para. 3.0) for the system engineering effort; (2) an adaptation of the system engineering management process specified in exhibit 1; (3) identification of the applicable documentation and adaptation thereof, specified in attachment 1, to be provided by the contractors; (4) identification of and plans for required reviews—namely, system requirements reviews, system design reviews, PDRs CDRs, FACIs, and technical approval demonstrations; (5) definition of contractor working relationships; and (6) establishment of contractor communication channels.

b. Specific requirements for the IAC or PC to take lead responsibility for incorporating SPO and GSE/TDC or SEG/R&T comments

and conditions of approval to assure that the system engineering documentation is integrated.

c. Schedules for system engineering documentation preparation, submittals, review, and use including requirements for the submission of system engineering documentation to the SPO, the GSE/TDC or SEG/R&T, the IAC or PC, and the participating contractors, as applicable.

d. During phases I and II, appropriate portions of the SEIP shall be incorporated as task requirements in the contractor work statements and the SEIP shall be kept current throughout the program.

9.0 SUMMARY OF SYSTEM ENGINEERING DOCUMENTATION AND APPLICATION CRITERIA.

Figure 6 provides summary criteria for the GSE/TDC or SEG/R&T in the selection of applicable data formats in this manual for a specific program. These criteria shall be applied with care to assure that the basic system engineering process reflected in this manual is not compromised. For example, for a small program, it may not be necessary to prepare, publish, and maintain maintenance loading information in the specific AFSCM 375-5 data formats in order to develop required MGE, spares, and personnel quantities in a systematic manner. However, the necessary analytical effort to correlate maintenance and personnel requirements by location in determining these quantities must still be made. Additional criteria for the selection of system engineering data are given below.

a. There are three other factors that must be considered in specifying the data requirements that will document the engineering process prescribed by this manual. Two of these are (1) the engineering documentation which must be prepared by the contractor and (2) the documentation which must be delivered to the Air Force. The two are not necessarily the same. The engineering documentation generated by the system engineering process should be selected for delivery to the Air Force on the basis of its actual need, not just because it may be available in the contractor's plant as a result of implementing the requirements of this manual. Both of these requirements must be con-

d. Review the technical content of system engineering documentation prepared by other contractors which affects their area of responsibility and effect required action.

e. Conduct required reviews and participate in technical interchange, technical direction, and integration meetings. Submit copies of the minutes of the reviews and meetings to the SPO for review and any required action.

5.3 Phase IC:

a. Provide technical clarification of the phase IB final report including phase II firm proposal upon request.

b. Accomplish additional system engineering as specified by the SPO during the "holding period."

5.4 Acquisition Phase (Phase II Development).

a. Accomplish system segment preliminary and detail design, production, test, acceptance, training, installation and checkout, and other activities necessary to effect system segment acquisition.

b. Prepare, maintain, and use required system engineering documentation as necessary to provide a basis for accomplishing paragraph a, above.

c. Submit input data to the IAC or PC as required for system level integration.

d. Review the technical content of system engineering and other documentation prepared by other contractors which affects their area of responsibility and effect required action.

e. Schedule and conduct required preliminary and critical design reviews as specified in paragraph 12, chapter 4, and participate in technical interchange, technical direction, and integration meetings.

6.0 INTEGRATING ASSEMBLY OR PRIME CONTRACTOR RESPONSIBILITIES. The IAC or PC shall accomplish the contractor activities described in exhibit I to assure detailed definition, integration, and satisfaction of the system requirements. Definitive levels of effort, required by the IAC or PC to comply with the following subparagraphs, shall be included in their work statements:

6.1 Phase IA. Since phase IA is an unfunded effort, the responsibilities listed below are suggested:

a. Take the same actions as are stated for a participating contractor for the portions of the system covered in the IAC's or PC's RFP.

b. Make and document system-level studies as required to interpret, develop, or expand overall system requirements.

c. Prepare, maintain, and use integrated system engineering documentation.

6.2 Phase IB:

a. Assume the same responsibilities as are stated for a participating contractor for the portions of the system covered in the IAC's or PC's contract.

b. Make and document system-level studies as required to interpret, develop, or expand overall system requirements.

c. Review the system engineering documentation prepared by the participating contractors for compliance with overall system requirements and technical adequacy.

d. Prepare, maintain, and use integrated system engineering documentation.

e. Convene and conduct integration meetings as necessary to accomplish timely integration of participating contractor inputs.

6.3 Phase IC:

a. Provide technical clarification of the phase IB final report including phase II firm proposal upon request.

b. Accomplish additional system engineering as specified by the SPO during the "holding period."

6.4 Acquisition Phase (Phase II Development). Assume the same responsibilities as are stated for a participating contractor for the portions of the system covered in the IAC's or PC's contract.

a. Make and document system-level studies as required to interpret, develop, expand, or synthesize overall system requirements and preliminary detailed design solutions.

b. Accomplish system preliminary and detail design, production, test, acceptance, training, installation and checkout, and other actions necessary for system acquisition. Maintenance of the integrated system engineering documentation shall include acting as lead contractor to implement the SPO and GSE/TDC or SEG/R&T comments or approval conditions.

c. Expand, maintain, distribute, and use integrated system engineering documentation as required to provide a basis for system synthesis.

d. Convene and conduct integration meetings as necessary for timely integration of participating contractor inputs. Record and distribute minutes of these meetings.

7.0 INTEGRATION OF REQUIREMENT DOCUMENTATION. The SPO will take specific steps for review of proposed contractor work statements to insure well-defined contractual and technical interfaces between the requirements of this manual and the requirements of related military specifications, including bulletins, exhibits, and standards that are not wholly included in this manual; e.g., reliability requirements of MIL-R-27542; maintainability requirements of MIL-M-26512; safety requirements of MIL-S-38130; personnel requirements of MIL-D-26239; cockpit design requirements of MIL-P-25898; and human engineering requirements of MIL-H-27894.

8.0 SYSTEM ENGINEERING IMPLEMENTATION PLAN. A detail SEIP shall be prepared by the GSE/TDC or SEG/R&T for inclusion in section 17, "definition plan," of the PTDP for the definition phase, and as section 17 of the PSPP for the acquisition phase. The SEIP shall identify:

a. AFSCM 375-5 requirements that are applicable to the system or project which will result in the most effective system engineering shall include (1) identification of specific SEG/R&T or GSE/TDC and contractors' responsibilities (reference para. 3.0) for the system engineering effort; (2) an adaptation of the system engineering management process specified in exhibit 1; (3) identification of the applicable documentation and adaptation thereof, specified in attachment 1, to be provided by the contractors; (4) identification of and plans for required reviews—namely, system requirements reviews, system design reviews, PDRs, CDRs, FACIs, and technical approval demonstrations; (5) definition of contractor working relationships; and (6) establishment of contractor communication channels.

b. Specific requirements for the IAC or PC to take lead responsibility for incorporating SPO and GSE/TDC or SEG/R&T comments

and conditions of approval to assure that the system engineering documentation is integrated.

c. Schedules for system engineering documentation preparation, submittals, review, and use including requirements for the submission of system engineering documentation to the SPO, the GSE/TDC or SEG/R&T, the IAC or PC, and the participating contractors, as applicable.

d. During phases I and II, appropriate portions of the SEIP shall be incorporated as task requirements in the contractor work statements and the SEIP shall be kept current throughout the program.

9.0 SUMMARY OF SYSTEM ENGINEERING DOCUMENTATION AND APPLICATION CRITERIA.

Figure 6 provides summary criteria for the GSE/TDC or SEG/R&T in the selection of applicable data formats in this manual for a specific program. These criteria shall be applied with care to assure that the basic system engineering process reflected in this manual is not compromised. For example, for a small program, it may not be necessary to prepare, publish, and maintain maintenance loading information in the specific AFSCM 375-5 data formats in order to develop required MGE, spares, and personnel quantities in a systematic manner. However, the necessary analytical effort to correlate maintenance and personnel requirements by location in determining these quantities must still be made. Additional criteria for the selection of system engineering data are given below.

a. There are three other factors that must be considered in specifying the data requirements that will document the engineering process prescribed by this manual. Two of these are (1) the engineering documentation which must be prepared by the contractor and (2) the documentation which must be delivered to the Air Force. The two are not necessarily the same. The engineering documentation generated by the system engineering process should be selected for delivery to the Air Force on the basis of its actual need, not just because it may be available in the contractor's plant as a result of implementing the requirements of this manual. Both of these requirements must be con-

AFSCM 375-5 DOCUMENTATION	DESCRIPTION	BASIC PURPOSE	APPLICATION	
FUNCTIONAL FLOW BLOCK DIAGRAM	IDENTIFY AND SEQUENCE THE SYSTEM AND SYSTEM ELEMENT FUNCTIONS THAT MUST BE ACCOMPLISHED IN ORDER TO ACHIEVE SYSTEM/PROJECT OBJECTIVES.	1. FACILITATES DEVELOPMENT OF SYSTEM REQUIREMENTS IN VIEW OF THE BASIC OPERATIONS THAT MUST BE ACCOMPLISHED TO ACHIEVE SYSTEM OBJECTIVES. 2. DEVELOPS THE BASIS FOR ESTABLISHING INTERSYSTEM FUNCTIONAL INTERFACES AS WELL AS IDENTIFYING SYSTEM RELATIONSHIPS.	ALL SYSTEM PROGRAMS AND PROJECTS FOR WHICH A DEFINITION OR ACQUISITION PHASE IS APPLICABLE OR DIRECTED. ALSO SELECTED PROJECTS IN THE ADVANCED DESIGN PHASE AND EXPEDITIONARY DEVELOPMENT ELEMENTS.	
REQUIREMENT ALLOCATION SHEET (RAS)	DEFINES THE REQUIREMENTS AND CONSTRAINTS PERTAINING TO EACH OF THE FLOW-BLOCK FUNCTIONS AND ADDITIONS TO THESE REQUIREMENTS TO EQUIPMENT FACILITIES, PERSONNEL, AND PROCEDURAL DATA.	1. FACILITATES DEVELOPMENT OF SYSTEM ELEMENT REQUIREMENTS ON A FUNCTIONAL HARDWARE BASIS. 2. FACILITATES CORRELATION OF HARDWARE AND PROCEDURAL DATA REQUIREMENTS TO THE FUNCTIONS THESE SYSTEM ELEMENTS ARE ACCOMPLISHING. 3. IDENTIFIES TRADE-OFF STUDIES REQUIRED TO DETERMINE MORE DETAILED SYSTEM DEFINITION.		
TRADE STUDY REPORT	DOCUMENTS THE TRADE-OFFS AND BACKUP STUDIES PERTAINING TO THE FUNCTIONAL DESIGN AND REQUIREMENTS DEVELOPED ON THE RAS DESIGN SHEET, SCHEMATIC TIMELINE SHEETS AND OTHER SYSTEM ENGINEERING DOCUMENTATION.	FACILITATES SYSTEMATIC CONSIDERATION OF ALL POSSIBLE SOLUTIONS IN VIEW OF DEFINED SYSTEM CONSTRAINTS AND SELECTION OF THE BEST SOLUTION.		
TIMELINE SHEET	PRESENTS SYSTEM FUNCTIONAL ELEMENTS IN THEIR REQUIRED SEQUENCE OF ACCOMPLISHMENT.	1. FACILITATES IDENTIFICATION OF THE ELEMENTS AND SPECIFIC SEQUENCE PARALLEL RELATIONSHIPS BETWEEN FUNCTIONS IN THE DEVELOPMENT OF SYSTEM ELEMENTS. 2. USED TO EVALUATE DESIGN EFFECTIVENESS IN TERMS OF REACTION TIME, PERFORMANCE TIME, MAINTENANCE, EQUIPMENT AND PERSONNEL UTILIZATION TIME.		
SCHEMATIC BLOCK DIAGRAM	SCHEMATICALLY IDENTIFIES AND REPRESENTS HARDWARE, COMPUTER PROGRAMS AND FACILITY SUBSYSTEM END-ITEM COMPONENTS, FUNCTIONAL INTERFACES AND INTERRELATIONSHIPS.	1. TO FACILITATE DEVELOPMENT OF HARDWARE AND COMPUTER PROGRAMS FACILITY ITEMS IN VIEW OF CONSTRAINING INTERFACES. 2. USED TO ALLOCATE REQUIREMENTS DEVELOPED ON THE RAS TO SYSTEM AND CONTRACT END-ITEMS.		
DESIGN SHEET	IDENTIFIES HARDWARE AND COMPUTER PROGRAMS AND FACILITY END-ITEM PERFORMANCE OBJECTIVES, TEST REQUIREMENTS, DRAWING SECTIONS AND FOR PARTS (DETAIL SPECIFICATION REFERENCE AFSCM 375-1).	DEFINES HARDWARE, COMPUTER PROGRAM AND FACILITY PERFORMANCE DESIGN AND "GO" CRITERIA ON AN END-ITEM BASIS.		
FACILITY INTERFACE SHEET	IDENTIFIES FUNCTIONAL AND PHYSICAL INTERFACES BETWEEN EQUIPMENT AND FACILITIES ON AN END-ITEM BASIS.	SUPPLEMENTS THE RAS TO COLLECT AND FURTHER DEVELOPE SPECIFIC EQUIPMENT INTERFACES WITH THE FACILITY ON AN END-ITEM RATHER THAN FUNCTIONAL BASIS.		ANY SYSTEM PROGRAMS OR PROJECTS FOR WHICH A DEFINITION OR ACQUISITION PHASE IS APPLICABLE OR DIRECTED AND THAT WILL RESULT IN EQUIPMENT THAT HAS COMPLEX INTERFACES WITH FACILITIES.
END-ITEM MAINTENANCE SHEET (MANUAL)	SUMMARIZES MAINTENANCE REQUIREMENTS ON A SPECIFIC END-ITEM SUB-ASSEMBLY AND COMPONENT BASIS.	FACILITATES SYSTEMATIC AND COMPLETE DEVELOPMENT OF MAINTENANCE REQUIREMENTS FOR EACH SYSTEM END-ITEM AND SUB-ASSEMBLY COMPONENTS.		ANY SYSTEM PROGRAMS OR PROJECTS FOR WHICH A DEFINITION OR ACQUISITION PHASE IS APPLICABLE OR DIRECTED AND THAT RESULTS IN RELATIVELY COMPLEX NON-STANDARD HARDWARE FACILITIES OR COMPUTER PROGRAM DEV WHICH WILL REQUIRE MAJOR LOGISTIC SUPPORT.
MAINTENANCE SHEETS AUTOMATED	SUMMARIZES MAINTENANCE REQUIREMENTS ON A SPECIFIC END-ITEM SUB-ASSEMBLY AND COMPONENT BASIS. PROVIDES DATA FOR CONFIGURATION MANAGEMENT, COMPUTER PROGRAMS AND DETAIL MAINTENANCE DATA ELEMENTS. MAY BE MODIFIED FOR MANUAL USE.	1. FACILITATES SYSTEMATIC AND COMPLETE DEVELOPMENT OF MAINTENANCE REQUIREMENTS FOR EACH SYSTEM END-ITEM AND SUB-ASSEMBLY COMPONENTS. 2. FACILITATES SORTING AND COMPILING SELECTED ELEMENTS OF LOGISTICS DATA IN SUPPORT OF AFM LOGISTICS ACTIVITIES.		ANY SYSTEM PROGRAMS OR PROJECTS FOR WHICH A DEFINITION OR ACQUISITION PHASE IS APPLICABLE OR DIRECTED AND THAT RESULTS IN RELATIVELY COMPLEX NON-STANDARD HARDWARE FACILITIES OR COMPUTER PROGRAM DEV WHICH WILL REQUIRE MAJOR LOGISTIC SUPPORT.
MAINTENANCE LOADING SHEET	CORRELATES MAINTENANCE FUNCTIONS AND TASKS INCLUDING FREQUENCY OF OCCURRENCE, TIME FOR ACCOMPLISHMENT, ETC. TO PERSONNEL, USE, AND SPARES.	1. FACILITATES DETERMINATION OF THE QUANTITY OF USE, PERSONNEL, AND SPARES REQUIRED TO MAINTAIN THE SYSTEM. 2. PROVIDES AN INPUT TO SYSTEM EFFECTIVENESS STUDIES IN TERMS OF UTILIZATION FACTORS.		ALL SYSTEM PROGRAMS AND PROJECTS FOR WHICH A DEFINITION OR ACQUISITION PHASE IS APPLICABLE OR DIRECTED AND THAT WILL REQUIRE ANY ONE OF THE FOLLOWING: 1. HIGH LAUNCH RATES AND INVOLVING A LARGE NUMBER OF FLIGHT VEHICLES OR END-ITEMS. 2. LARGE NUMBERS OF DIFFERENT END-ITEMS OF A RELATIVELY COMPLEX AND NON-STANDARD NATURE. 3. LARGE NUMBERS OF END-ITEMS DEPLOYED IN HEAVILY DEPLOYED AREAS.
PERSONNEL UTILIZATION SHEET	IDENTIFIES MAINTENANCE PERSONNEL EFFORT BY SPECIFIC MAINTENANCE LOCATION.	1. FACILITATES IDENTIFICATION OF TOTAL MAINTENANCE PERSONNEL REQUIREMENTS. 2. PROVIDES INPUT TO MAINTENANCE LOADING SHEET.	ALL SYSTEM PROGRAMS AND PROJECTS FOR WHICH A DEFINITION OR ACQUISITION PHASE IS APPLICABLE OR DIRECTED THAT WILL BE TURNED OVER TO AN AIR FORCE USING COMMAND OR THAT INVOLVE A LARGE NUMBER OF END-ITEMS REQUIRING PERIODIC CALIBRATION.	
CALIBRATION REQUIREMENTS SUMMARY	SUMMARIZES EQUIPMENT CALIBRATION REQUIREMENTS AT EACH LEVEL OF CALIBRATION.	PROVIDE A CONVENIENT SUMMARY TO DEFINE SYSTEM CALIBRATION AND REPAIRING STANDARD REQUIREMENTS.	ALL SYSTEM PROGRAMS AND PROJECTS FOR WHICH A DEFINITION OR ACQUISITION PHASE IS APPLICABLE OR DIRECTED AND THAT WILL RESULT IN USE DEVELOPMENT WHICH WILL BE REQUIRED BY AFM.	
EQUIPMENT PROVISIONING FIGURE A	DEFINE USE END-ITEM ORDERING DATA.	PROVIDE USE PROVISIONING DATA TO AFM ON AN END-ITEM BASIS.	ALL SYSTEM PROGRAMS AND PROJECTS FOR WHICH A DEFINITION OR ACQUISITION PHASE IS APPLICABLE OR DIRECTED AND THAT WILL RESULT IN USE DEVELOPMENT WHICH WILL BE REQUIRED BY AFM.	

Figure 6. Summary of System Engineering Documentation and Application Criteria.

sidered independently and clearly identified on the DD Form 1423 of the contract.

b. The level of detail to which the engineering documentation is carried by the contractor is the third factor that must be considered and specified in the contract. Normally this should be limited to the CEI level or the level to which all items of deliverable hardware are identified and for which specifications are written. A specific level (e.g., 6th indenture) should not be specified since this could result in more detail than necessary. Configuration management, as specified in AFSCM 375-1, is basically concerned with the CEI level, and the engineering management specified by this manual need complement it only with the engineering data at this same level.

10.0 SYSTEM ENGINEERING DOCUMENTATION USES. Uses of the system engineering documentation will vary depending upon the specific nature of a system or project. As a minimum, the system engineering documentation defined herein shall be utilized during the system life cycle as specified in the subparagraphs set forth below. The primary system engineering documentation to be utilized is parenthetically noted after each required use. System engineering documentation integrated by the IAC or PC shall be used by all contractors and Air Force organizations subsequently to its submission or availability for use in whole or in part. Prior to the submission or availability of the integrated documentation, individual contractor-developed documentation shall be utilized.

10.1 Conceptual Phase Uses:

a. Provide technical inputs to the PTDP (functional diagrams, RASs, Trade Study Reports, time-line sheets).

b. Provide justification and rationale for technical data in PTDP (Trade Study Reports).

10.2 Definition Phase Uses:

a. Provide a basis for preparation of the initial specification tree and revisions/expansions thereto (functional diagrams, RASs, Trade Study Reports, time-line sheets, schematic diagrams, and design sheets).

b. Provide requirements for inclusion in the initial system specification and revisions/expansions thereto (functional diagrams, RASs, Trade Study Reports, time-line sheets, schematic diagrams, and design sheets).

c. Provide requirements for reliability and system effectiveness models (functional diagrams, RASs, Trade Study Reports, time-line sheets, schematic diagrams, design sheets, facility interface sheets, and maintenance sheets).

d. Provide test concepts and overall requirements to support test planning and development (functional diagrams, RASs, Trade Study Reports, schematic diagrams, and design sheets).

e. Provide backup requirement documentation to support the phase IB work statement and phase II specimen work statement preparation (functional diagrams, RASs, Trade Study Reports, time-line sheets, and schematic diagrams).

f. Provide basic requirement documentation in support of contractor phase IA proposal preparation effort (functional diagrams, RASs, Trade Study Reports, time-line sheets, schematic diagrams, design sheets, and facility interface sheets).

g. Provide basic requirement documentation for SPO and GSE/TDC or SEG/R&T and contractor reviews of the phase IB effort (functional diagrams, RASs, Trade Study Reports, time-line sheets, schematic diagrams, design sheets, facility interface sheets, and maintenance sheets).

h. Provide performance, design, and test requirements for Part I Detail Specifications, including specifications for test and activation peculiar end items (functional diagrams, RASs, Trade Study Reports, time-line sheets, schematic diagrams, design sheets, facility interface sheets, and maintenance sheets).

i. Provide requirements for personnel, training, and procedural data in the form of initial QQPRI, TEPI, and procedural data list respectively (functional diagrams, RASs, Trade Study Reports, and time-line sheets).

j. Provide documentation to support the evaluation of contractor phase IB and II proposals and phase IB final reports (functional

diagrams, RASs, Trade Study Reports, time-line sheets, schematic diagrams, design sheets, facility interface sheets, and maintenance sheets).

10.3 Acquisition Phase Uses:

a. Provide a basis for the expansion and verification of the System Specification and Detail Specifications and preparation of drawings (functional diagrams, RASs, Trade Study Reports, time-line sheets, schematic diagrams, MGE, design sheets, facility interface sheets, and maintenance sheets).

b. Provide category I, category II, acceptance, and I&C test requirements for inclusion in the System Specification and Detail Specification and in support of the development of detailed I&C, category I, and category II test procedures, plans, directives, and other test documentation (functional diagrams, RASs, Trade Study Reports, time-line sheets, and schematic diagrams).

c. Provide basic requirement documentation to support reviews, including PDRs and CDRs, and provide backup requirement documentation to support FACIs, acceptance tests, and technical approval demonstrations (functional diagrams, RASs, Trade Study Reports, time-line sheets, schematic diagrams, facility interface sheets, and maintenance sheets).

d. Provide basic system element requirements for inclusion in activation, operations, and maintenance procedural data (functional diagrams, RASs, Trade Study Reports, time-line sheets, schematic diagrams, maintenance sheets, and maintenance loading documentation).

e. Provide basic requirement data in support of problem evaluation, test result evaluation, and required change definition during acceptance, I&C, category I, and category II testing (functional diagrams, RASs, Trade Study Reports, time-line sheets, and schematic diagrams).

f. Provide the basic quantitative and qualitative requirements for personnel to prepare QQPRI (functional diagrams, RASs, Trade Study Reports, time-line sheets, maintenance loading documentation including personnel utilization sheets, maintenance sheets, and calibration requirements summaries).

g. Provide requirement documentation for defining the training program (functional diagrams, RASs, Trade Study Reports, time-line sheets, schematic diagrams, maintenance sheets, and maintenance loading documentation).

h. Provide basic requirement data for equipment and facility quantities, spare part provisioning, servicing, equipment calibration, depot overhaul, and other logistics support requirements (functional diagrams, RASs, Trade Study Reports, time-line sheets, schematics, maintenance loading documentation including MGE utilization sheets, maintenance sheets, MGE provisioning lists (Figure A), and calibration requirements summaries).

i. Provide basic requirements for I&C and selected critical production activities (functional diagrams, RASs, Trade Study Reports, time-line sheets, schematic diagrams, and maintenance sheets).

j. Provide basic requirement documentation in support of category III test requirement development, test procedures, test plans, and other test documentation (functional diagrams, RASs, Trade Study Reports, time-line sheets, and schematic diagrams).

10.4 Operational Phase Uses:

a. Provide basic requirement documentation in support of follow-on operational test requirement development, test procedures, test plans, and other test documentation (functional diagrams, RASs, Trade Study Reports, schematic diagrams, and time-line sheets).

b. Provide technical requirements in support of (1) problem evaluation and required changes to category III and follow-on operational testing, (2) the analysis of system test data, and (3) follow-on system modifications (functional diagrams, RASs, Trade Study Reports, schematic diagrams, time-line sheets, maintenance sheets, and maintenance loading documentation).

10.5 Engineering Change Justification. The system engineering documentation shall be used to provide definition and justification of technical changes to design requirements, specifications, drawings, and equipment/facilities in support of AFSCM 375-1 configuration management activities: e.g., providing the substan-

tiation of performance effectiveness required by block 21 of the ECP form (functional diagrams, RASs, Trade Study Reports, schematic diagrams, time-line sheets, facility interface sheets, design sheets, maintenance sheets, and maintenance loading documentation).

11.0 SPECIAL APPLICATIONS OF AFSCM 375-5. It is advantageous for systems and projects that are in the exploratory or advanced development program element of the R&D program VI to implement selected requirements from this manual.

a. The development of three basic system engineering documentation elements can most contribute to such programs: namely, functional diagrams, schematic diagrams, and directly related engineering studies. Functional diagrams can be prepared to identify and interrelate the basic functions necessary to accomplish the system or project objectives. Engineering studies can then be performed to define the requirements associated with the functions in conjunction with the schematic diagrams and to apportion these requirements to equipment, personnel, and facilities as applicable. Studies should reflect the overall content requirements of the RASs and Trade Study Reports. Trade-offs would be an inherent part of such studies. For certain advanced development program element systems or projects such as X-15, the addition of the RASs and design sheets can be beneficially utilized for determining total integrated requirements.

b. Advantages that can be gained through the selective application of the requirements of this manual to such systems are that it would (1) accomplish the system or project objectives in a systematic manner starting with an analysis of the function and the subsequent determination of the system functional requirements that must be satisfied to meet these objectives; thereby providing a functional framework to be used as a complete checklist to assure that the system elements are developed in view of all system requirements and constraints, (2) provide a permanent record and rapid determination of the rationale behind the decisions made during the accomplishment of the system or project objectives; (3) facilitate transition of the system engineering effort accomplished while a system

or project is categorized in an exploratory or advanced development program element, to the system engineering effort required in the event that the system or project is reclassified as an engineering or operational system development program element; and (4) provide a structured source of system requirements to facilitate communication within the contractor's organization and between the contractor and the SPO.

12.0 SYSTEM ENGINEERING DOCUMENTATION FORMAL SUBMITTAL. Contractors shall complete and submit system engineering documentation required on the DD Form 1423 (reference para. 8 of chapter 3) in accordance with figure 7 and the contractual submittal schedules. Only the data which are required for delivery on the DD Form 1423 will be submitted. Figure 7 represents a typical participating contractor/IAC/PC submittal and TD/comment loop during the definition and acquisition phases. Final formal submittal during the definition phase will be as a part of the phase IB final report. Where only a prime or single contractor or contractor team is involved, submittals shall be made directly from the contractor to the SPO. The system engineering documentation shall be "packaged" for formal submittal in accordance with the following subparagraphs unless otherwise agreed to by the SPO and the contractor:

12.1 Volume I—Introduction and Indexes. This volume shall include general instructions for the use of all the volumes, including a brief explanation of each documentation element, its use, and its relationship with other documentation elements. Included shall be a listing of source data such as the SOR/OSR/ADO, conceptual study reports, and specialized data related to a specific aspect of the system. It shall also include a general table of contents for all volumes, and a general index which shall be subject oriented and relate to specific volumes and pages. The index subject headings will depend on the nature of the specific program. For example, it may contain such general headings as "Equipment" under which may be listed "Launch Complex OGE" or "Electrical Power Equipment," "Vehicle Handling Equipment," or "Guidance Equipment," etc. Correlation to the related system engineering documentation

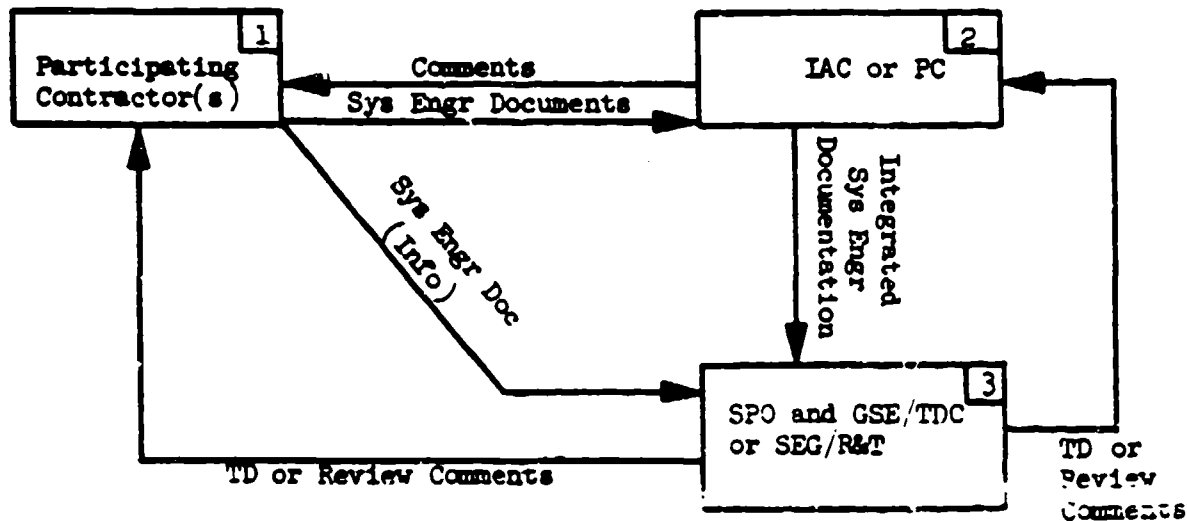

Figure 7. System Engineering Documentation Submittal and TD/Comments Flow.

would then be made by volume and page number for each subheading. Another general heading may be "Personnel," under which may be listed "AFSC," "Maximum Personnel per Maintenance Team," etc. Individual volumes and logical groupings of data within these volumes of over 25 pages shall have functions or equipment/facility end item identifiers related to page numbers.

12.2 Volume II—Functional Documentation. This volume shall contain operations, test, and activation functional diagrams and related RASs and tie-line sheets in numerical and decimal sequence.

12.3 Volume III—Trade Study Reports. This volume shall be used to report the required trade study prepared in support of the system engineering effort. The Trade Study Reports to be submitted shall be directed by the SPO.

12.4 Volume IV—Schematic Diagrams. This volume shall contain system and subsystem schematic diagrams organized in a logical, progressive manner.

12.5 Volume V—Equipment/Facility Documentation. This volume shall contain equipment and facility design sheets and facility interface sheets. As the design sheet becomes Part I of Detail Specifications, they shall be replaced by a reference to the specific Detail Specifications. Where design sheets are not prepared for equipment (e.g., inventory equipment requirements items and identification items), a refer-

ence to the appropriate detail specification shall be included. Equipment categorization within this volume shall be as follows:

- a. AVE.
- b. OGE.
- c. MGE.
- d. AAE.
- e. Facilities.

12.6 Volume VI—Equipment/Facility Maintenance Requirements. This volume shall contain maintenance functional diagrams and maintenance sheets.

12.7 Volume VII—Maintenance Loading Documentation. This volume shall contain all the maintenance loading sheets, MGE utilization sheets, and personnel utilization sheets.

12.8 Volume VIII—Calibration Requirement Summaries. This volume shall contain the calibration requirement summaries sectionalized by equipment category as in volume V.

13.0 SYSTEM ENGINEERING DOCUMENTATION CHANGES. Changes to any portion of the system engineering documentation that have been submitted to the IAC or SPO or that have been made available for the participating contractors internal use shall be specifically controlled and issued in a timely manner to insure currency of the submitted or available documentation.

- a. Changes to system engineering documentation resulting from or leading to engineering changes that are controlled in accordance with

the requirements of AFSCM 375-1 (class I changes) shall be submitted as part of the specification change notice, and system requirements, design requirements, and normal ECPs. The specific word change to the system engineering documentation, amplified as necessary to define or justify the specific engineering change, shall be included in the change proposal.

b. System engineering documentation changes leading to or resulting from engineering changes not requiring approval by the SPO or in accordance with AFSCM 375-1 (class II changes) shall be incorporated in the integrated documentation on an "as identified" basis.

c. Changes to system engineering documentation shall be reflected in the participating contractors data and the IAC integrated data.

d. System engineering document changes shall be submitted in the same manner as original submittals as represented on figure 7 when not associated with AFSCM 375-1 change proposals. When associated with such change proposals, they shall be submitted as an integral part of the change proposals in accordance with AFSCM 375-1.

13.1 Revisions. The following is a suggested method of editorially revising system engineering data:

a. Documentation requiring revision of over 50 percent of the original pages shall be submitted as a total revision identified by a letter change.

b. Documentation requiring revision of less than 50 percent of the content shall be changed by the submission of Document Revision Notices (DRN). DRNs shall not be required for documentation changes prior to initial submission or availability of the documentation. The format of the DRN shall be established by

the IAC or PC and shall contain, as a minimum, a title block identifying the documents to be changed, date, originator, etc., a description of change, section identifying the old and new information, a reference to the related AFSCM 375-1 change proposal identifier, and a signature approval block.

c. A DRN shall be forwarded with each volume initially submitted. In this case, the text within the body of the DRN under "Description of Change" shall state "Initial Submission." A dash (—) shall be entered as the identifier following the document number.

d. A DRN shall be used to forward each change submitted. In this case, the description of change information shall, in addition to describing the change, reference each affected element of the system engineering documentation; i.e., function number, number identifying the design sheet (CEI number), paragraph reference, etc. The DRN will be identified with the revision letter of the document to which it applies followed by a sequentially assigned numeric suffix; e.g., "LM 1234-C-2" would be the second DRN issued against the C (third) revision of the functional diagram identified by drawing number LM 1234. When used to support AFSCM 375-1 change proposals, etc., DRNs shall be appropriately amplified and integrated with the change proposal to completely define and/or justify the basic system change.

e. Revisions directed by the SPO shall not be constituted as authority to delay documentation change incorporation by means of DRN procedures. A master file of complete change status shall be maintained in a control location within each participating contractor's organization. This master file shall at all times reflect the current system configuration.

DETAIL REQUIREMENTS FOR COMPLETING SYSTEM ENGINEERING DOCUMENTATION

1.0 PREPARATION OF FUNCTIONAL FLOW BLOCK DIAGRAMS. Functional diagrams are drawings, to be approved and released internally within a contractor's facility in the same manner as other engineering drawings. Functional diagrams are developed for the primary purpose of structuring system requirements into functional terms, and the main emphasis shall be on accuracy and completeness rather than upon format. However, as an aid in developing, interpreting, and providing standardization necessary to accomplish interfaces between contractors, certain basic rules and symbols have been developed and shall be followed, whenever practical, in the physical layout of the functional diagrams. These requirements are covered in subsequent paragraphs. The functional identification and basic symbols for functional diagrams are illustrated in figure 8.

1.1 Function Numbering. Functions identified on the functional diagrams at each level shall be numbered in a manner which preserves the continuity of functions and provides information with respect to function origin throughout the system. Functions on the top level functional diagram shall be numbered 1.0, 2.0, 3.0, etc. Functions which further indenture these top functions shall contain the same parent identifier and shall be coded at the next decimal level for each indenture. For example, the first indented function of function 3.0 would be 3.1, the second 3.1.1, the third 3.1.1.1, etc. For expansion of a higher level function within a particular level of indenture, a numerical sequence shall be used to preserve the continuity of function. For example, if more than one function is required to amplify function 3.0 at the first level of indenture, the sequence shall be 3.1, 3.2, 3.3, . . . 3.n. For expansion of function 3.3 at the second level, the numbering shall be 3.3.1, 3.3.2, 3.3.n. Where several levels of indentures appear on a single functional diagram, the same pattern shall be maintained. While the basic ground rule shall be to maintain a minimum level of indentures on any one particular flow, it may become necessary to include

several levels to preserve the continuity of functions and to minimize the number of flows required to functionally depict the system. The general criteria for the number of functions and level of indentures appearing on any particular flow shall be accuracy and clarity of presentation based on judgment.

1.2 Function Reference. Each functional diagram shall contain a reference to its next higher functional diagram through the use of a reference block. For example, function 4.3 should be shown as a reference block in the case where the functions 4.3.1, 4.3.2, 4.3.n, are being used to expand function 4.3. Reference blocks shall also be used to indicate interfacing functions as appropriate.

1.3 Function Block. Each separate function on a functional diagram shall be presented in a single box enclosed by a solid line as depicted in figure 8. Blocks used for reference to other flows shall be indicated as partially enclosed boxes labeled "Ref." Each function may be as gross or detailed as required by the level of functional diagram on which it appears, but it shall stand for a definite, finite, discrete action to be accomplished by equipment, personnel, facilities, or any combination of the three. Questionable or tentative functions shall be enclosed in dotted blocks as depicted by figure 8.

1.4 Flow Connection. Lines connecting functions shall indicate only the functional flow, and shall not represent either a lapse in time or any intermediate activity. Vertical and horizontal lines between blocks shall indicate that all functions so interrelated must be performed in either a parallel or series sequence as indicated. Diagonal lines may be used to indicate alternative sequences (cases where alternative paths lead to the next function in the sequence). In this latter case, the use of a diagonal line indicates that any of the functions so interrelated will lead to the next indicated function.

1.5 Flow Direction. Functional diagrams shall be laid out so that the functional flow is from left to right and the reverse flow, in the case of a functional loop, from right to left.

Primary input lines shall enter the function block from the left side; the primary output or "go" line shall exit from the right and the "no go" line from the bottom of the box. However, where other considerations dictate a different arrangement to highlight a physical area, level of maintenance, or other significant consideration, a different arrangement might be employed.

1.6 Summing Gates. A circle shall be used to depict a summing gate. As in the case of functional blocks, lines shall enter and/or exit the summing gate as appropriate (reference fig. 8). The summing gate is used to indicate the convergence or divergence of parallel or alternative functional paths and is annotated with the terms "AND" or "OR." The term "AND" is used to indicate that parallel functions leading into the gate must be accomplished before proceeding into the next function or that paths emerging from the "AND" gate must be accomplished after the preceding function. The term "OR" is used to indicate that

any of several alternative paths (alternative functions) converge to or diverge from the "OR" gate. The "OR" gate thus indicates that alternative paths may lead to or follow a particular function.

1.7 GO—NO GO Paths. The symbols "G" and "Ḡ" are used to indicate "GO" and "NO GO" paths. The symbols are entered adjacent to the lines leaving a particular function to indicate alternative functional paths (reference fig. 8).

1.8 Numbering Procedure for Changes to Functional Diagrams. In order to provide a rapid means for changing flows without causing extensive or chain reaction revision of numbering, the following procedure shall be used. Additions of functions to existing data shall be accomplished by locating the new function in its correct position without regard to sequence of numbering. The new function shall be numbered using the first unused number at the level of indenture appropriate for the new function. Example:

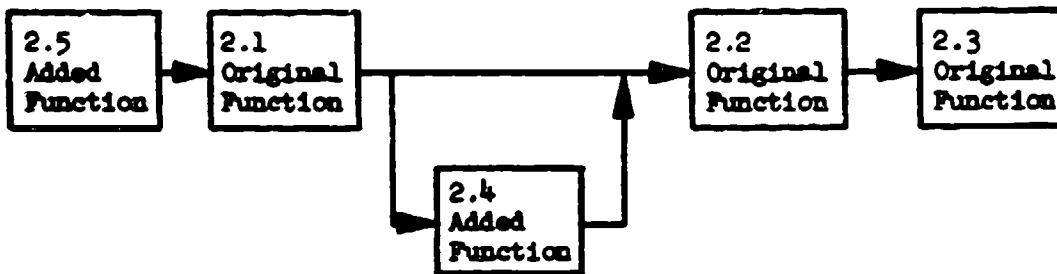

When previously established functions must be redelegated to a different functional string, the function to be moved shall be considered retired and the new location of that function shall be

considered as a new addition to the acquiring strings and shall be treated as above. Example:

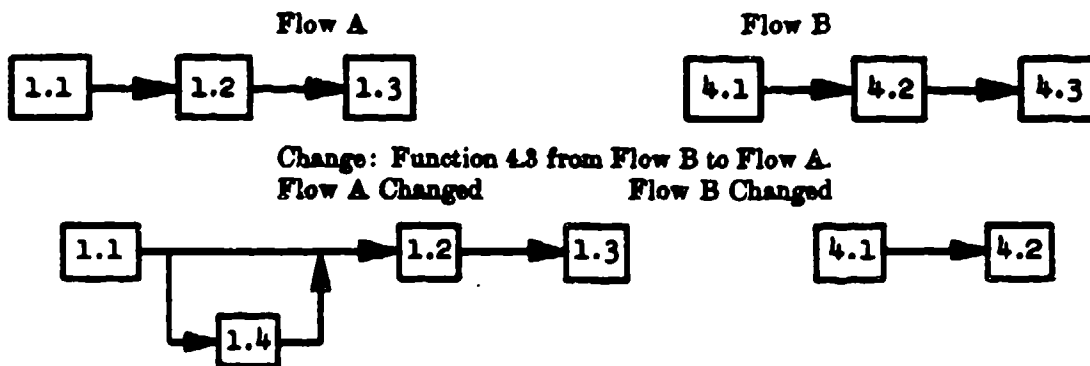

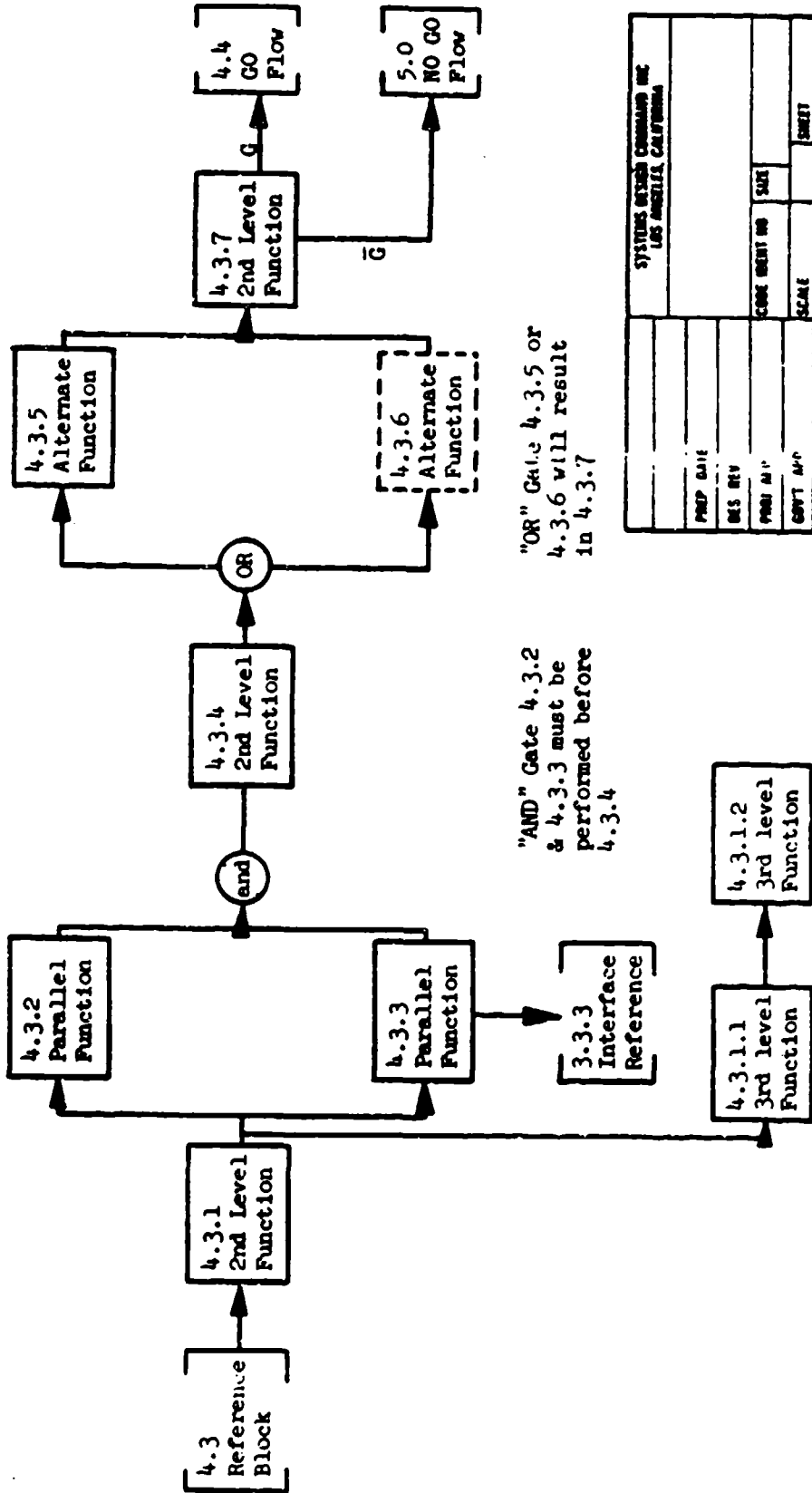

Figure 8. Format for Functional Flow Block Diagram.

1.9 Example of Functional Diagram. For examples of functional diagrams, reference attachment 2.

1.10 AFSCM/AFLCM 310-1 Data Item Number. Reference S-52-6.1.

2.0 REQUIREMENTS ALLOCATION SHEET. Requirements allocation sheets (RAS) shall contain an analysis of each function or group of functions depicted on the functional diagrams and shall be submitted in the format* presented in figure 9 in accordance with the following requirements:

Block A—Reference the title and number of the drawing containing the functional diagram from which the functions being analyzed originated. When the RASs are used to document the analysis of the functions on the end item maintenance sheets, enter the nomenclature and number of the CEI. The number shall be the applicable CEI number, of index number (reference column E2).

Column B—Enter the name and number of each block on the referenced functional diagram in numerical sequence. Subfunctions which evolve as a product of the RAS analysis but which are not identified as discrete functions on the functional diagram may be identified in this column to minimize unnecessary diagram expansion. Functions shall be expanded by a list of these subfunctions only when additional design requirements are generated. When the RAS is used to document the analysis of the functions on the end item maintenance sheet, column B shall contain the following:

1. Line item—the horizontal line number entry on the end item maintenance sheet.

2. Description of the maintenance functions on the end item maintenance sheet.

Column C—This column contains design requirements which result from analysis of the function identified in column B. These requirements shall be developed and expanded in detail to provide technical criteria for recommending and evaluating methods of satisfying each functional requirement in terms of a given combination of equipment, facilities, and personnel. These requirements are developed in equal depth

*NOTE: Format size and typing for all sheets required by this attachment shall be commensurate with good commercial practice, reasonableness of cost, and providing a copy which is legible and convenient to use. The sheet size and typing shall be coordinated between SPO and all contractors to insure uniformity among contractors.

for maintenance functions reflected on the maintenance sheets as well as operational and maintenance functions identified on functional diagrams. The objectives of the design requirement entries are to (1) establish functional and design requirements for inclusion in the design sheet and, subsequently, into the requirements section of the Part I Detail Specification; (2) initiate recognition of intrasystem and intersystem interface requirements and facility requirements; and (3) initiate recognition of personnel requirements. Design requirement entries shall include:

1. Description of the function including the "what" and "why" of the function; i.e., answering the questions: Why is the function necessary? Why should the functions be accomplished at this point in the sequence of actions? What engineering characteristics of this function are related to engineering characteristics of another function?

2. Specific design characteristics created by the function; i.e., input, output, performance values, and allowable quantitative tolerances. Include maintenance requirements as applicable such as checkout limits, calibration limitations and requirements, accessibility requirements, limiting prerequisites such as identification of pressurized and toxic environments, critical disassembly requirements, etc. Detail should be sufficient for direct use as criteria which initiate and control the system and system element design. Included should be technical detail sufficient for engineering to extract portions of one or more RASs and in conjunction with schematics reassemble them into the design sheet as integrated design requirements.

3. Requirements which constrain or have significant influence on design such as power, physical dimension and weight, controlled and natural environment, and human performance capabilities and limitations. Time constraints either created by or constraining the function shall be identified. Illustration of such constraints might be computation-solving times, countdown or event timing, and time budget allocations established as a part of system availability or effectiveness studies.

4. Requirements for effectiveness factors (i.e., reliability, maintainability, and transportability), safety, and survivability/vulnerability.

5. Functional and technical interface requirements evolving from analysis of the func-

tion shall be separately identified to facilitate interface surveillance and collection. The requirements describing the interface shall be specific and quantified. Where intersystem interface is specified, the configuration of that system shall be specified together with the technical characteristics of the interface. *NOTE:* Where the above requirements are products of Trade Study Reports or other backup studies, specifications, etc., a specific reference to that document shall be made.

Column D—This column shall contain the facility requirements imposed by the design requirements in column C. The entries shall identify:

1. Controlled and natural environmental requirements: e.g., temperature and humidity ranges, illumination and noise levels, wind and snow loading, precipitation, penetration and abrasion effect, and atmospheric pressure.

2. Utility requirements; e.g., power (electrical, hydraulic, etc.), air conditioning, ventilation, and heating to be satisfied by the facility.

3. Civil/structural/architectural requirements. Requirements for structures shall be in terms of functional requirements, induced environment, and minimum dimensions. Requirements for space, access, and monitoring in existing structures shall be described in terms of minimum dimensions necessary to accommodate the equipment.

4. Facility equipment, if identified earlier in the system engineering process.

The following is a list of considerations for specifying site, building, and special equipment requirements:

1. *Site Preparation:*

a. The need for disposal of commercial and domestic wastes, and whether buried services (electrical, telephone, water, gas, propellants) are required must be stated.

b. To support road and rail requirements, such items as maximum wheel load, radius of turns, widths, maximum grade, and parking needs must be stated.

c. To determine clearances for facilities, define acoustic, blast including fragmentation pattern, and toxic levels, as well as security and access requirements.

2. *Buildings:*

a. Occupancy of a building must be defined by considering its prime function, the number of personnel it must accommodate, the

services it must provide, and whether or not time is a factor.

b. Dimensional requirements evolve from the controlling features of the major item to be housed (such as transporter dimensions).

c. Heating and ventilation requirements are established from equipment operational and/or personnel needs. Environmental requirements derived from such needs should be stated in specific terms, such as "Room temperature shall range from 70°-80° F. dry bulb and relative humidity shall not exceed 55 percent at 80° F. dry bulb. Heat dissipation of — B.t.u./hr. will be emitted from the equipment.

d. Acoustical requirements are established to insure acceptable noise levels.

e. Communications requirements (excluding electronic gear) for cabling, towers, ducts, and public address systems are derived from the urgency of certain tasks.

f. Services such as electrical power requirements must be stated in volts, amperage, or KW load and frequency; illumination in terms of required intensity; and water in terms of required flow and pressures.

3. *Special Equipment:*

a. Crane requirements must be supported by the required capacity, number of hooks, envelope to be serviced by the crane, speed of hook, or bridge travel.

b. Elevators should be supported by their prime use, required capacity of freight/passengers, number of floors to be serviced, and whether operation should be manual or automatic.

c. Requirements for moving platforms shall state access, location (including required elevators), capacity, and manual or power operation, as well as time elements involved.

d. Mobile structures are defined by their prime use, loading, envelope of service, time elements, special requirements, services on structure, and personnel involved shall be stated.

e. Power generation requirements must be supported by the criticality of designated loads, their demand and load vs time pattern, and reliability of service required.

f. Propellant storage requirements must state fuel to be stored, its toxicity and handling hazards, capacity required, pumping and transfer method, and whether fire water systems and decontamination systems are required.

(For facility system engineering contractors, this column shall contain requirements on other RPIE subsystems or civil/structural/architectural requirements imposed by the critical RPIE subsystems under analysis in column C.)

Column E:

Column E1—Enter the short-form nomenclature of the end item of AVE, OGE, MGE, AAE, or facility equipment, or items of equipment for which a design sheet or applicable Detail Specification is not required. Once nomenclature is used against a given function or within a given function, the item may be identified thereafter by number if available.

Column E2—Enter the CEI number or applicable Detail Specification number or index number corresponding to the nomenclature.

(Items necessary for the support of the mission not identified on design sheets or Detail Specifications shall be identified by an index number. A list of these items shall be prepared and maintained by the integrating or prime contractor with inputs from associate contractors. Examples of these items include locally procured/base purchased, technical operating equipment, vehicle authorization list, locally manufactured items, special tools, and common hand tools. Greases, lubricants, abrasives, etc., shall also be identified. The list must contain the Federal stock number and LP/BP coding or the manufacturer's identification if the FSN is not available and usage and quantity recommended. The list shall identify the specific item and reference the RAS on which the requirement for the item originated. Index numbers shall be assigned by the integrating or prime contractor to each item in the list to provide an appropriate reference number for the RASs. Care should be taken in assigning index numbers to prevent duplicating CEI numbers.) AFR 67-3 should be used as a guide in determining locally procured/base procured items.

Column F—For functions that are to be completely automated and will not involve personnel, this column may be eliminated. For these functions a separate sheet may be used with columns B, C, D, and E only for efficient presentation.

Column F1—Enter the human perform-

ance task requirements which constrain or significantly affect accomplishment of the requirements stated in columns B and C. These task requirements shall be specified to the level of technical depth that will facilitate identification of human engineering requirements and procedure development. Detail task identification and analysis (when required) shall be a separate but correlated effort. Procedural instructions shall not be included. As task is defined as a concise statement of a unit of work that cannot be reduced into two or more significant parts. If a breakdown of a statement of work would result in stating obvious actions such as "Bolt in place" or "open access door," the breakdown is not to be considered significant. If a statement of work to be performed by equipment, facilities, personnel, or some combination thereof, can be broken into two or more significant parts, it is a function. For example, "Install communication equipment" can be broken into at least two significant parts: "Install transmitting equipment" and "Install receiving equipment." Task requirement shall be identified by alpha-numeric extensions of the function number in column B. For example, function 3.1.2 would have corresponding tasks numbered 3.1.2.a, 3.1.2.b, etc., 3.2.1.n, with task breakdown numbered 3.1.2.a.1, 3.1.2.a.2, etc.

Column F2—Enter the elapsed time required to accomplish the task in seconds, minutes, hours, or days to the first decimal. Use S=sec., M=min., H=hour, D=day, e.g., 3.5 S means 3.5 seconds.

Column F3—For the task requirements outlined in F1 which demand human performance, make the following entries as appropriate:

1. Crew coordination; i.e., if the task requires more than one person, define the coordination requirement, including the communications necessary, if any, and number of personnel involved.

2. Job knowledge; i.e., state whether theory of operation is required or just an understanding of the procedures necessary to accomplish the task.

3. Making decisions; i.e., if the task requires judgment or decision, summarize action and the criteria which control that action.

4. Safety procedures; i.e., if the task requires more than normal caution to prevent injury to personnel, or equipment malfunction, summarize the procedural criteria which will minimize risk.

5. Performance under stress; i.e., if the personnel actions are to be performed under time or technical stress, summarize the significant conditions under which stress occurs.

6. Skill demands for critical tasks; i.e., define perceptual judgmental, and motor demands.

7. Define sustenance and other life support requirements imposed by the functions and design requirements.

Column F₁—Enter training and training equipment requirements to indicate the extent of training required and whether training equipment or aids are required as well as the recommended type for the functions and tasks identified in columns B and F1. The following code shall be used to indicate the extent of training required:

X Requires no training.

A Requires a general familiarization through discussion and/or demonstration.

B Requires a briefing on the knowledge or job task to meet the job requirements; does not need to apply the information received.

C Requires a briefing on the knowledge or job task to meet the job requirements; needs to apply the information received in a non-job-like situation, such as written tests or verbal problem-solving situations.

D Requires a briefing on the knowledge or job task; needs to perform or apply representative portions of the job task or knowledge in a job-like situation either on actual equipment or trainers.

E Requires a briefing on the knowledge or job task; needs to perform the complete job task or apply the knowledge in a job-like situation on actual equipment or trainers.

F Same as E but performed a sufficient number of times to insure proficiency in all phases of performance.

(The training equipment or aids recommended shall be one of the following three classes: class 1 includes trainers such as (1) mission simulator, (2) part-task trainer, (3) training attach-

ments; class II includes actual AVE, OGE, MGE, or facility end items and parts and components thereof; and class III includes training aids such as (1) animated panels, (2) cutways, (3) exploded or site displays, (4) training films, (5) charts and transparencies. Requirements for mobile training units (MTUs) shall be identified. For training equipment end items, the CEI number of applicable Detail Specification number shall be entered in this column as appropriate.)

Column G—Functions which produce complicated or hazardous requirements involving personnel will generally dictate the need for procedural information. Column G provides the means for assuring that the contractor has considered available data, and, where not available, has programed development of the procedural data. Entry in this column shall in all cases be specific. For engineering development programs where a technical order contract has not been established, enter the nomenclature, number, and type of procedural data available or to be established (test directives, test procedures, or specific equipment procedures). Where the requirements are applicable to operational military programs, include the T.O. number in existence or to be established; the type of T.O.; e.g., operating instructions, explosive ordnance instructions, and calibration requirements. Include the applicable T.O. preparation specification against each type of data to be prepared. Commercially available publications may be applicable to either development engineering efforts or operational military programs. Application of these data shall be indicated by title, document number, and supplier. In any category previously described, changes required to make existing procedural data suitable for the technical requirement involved shall be noted by a parenthetical (c) following document number; i.e., Sperry Gyro 25656 G (c) or T.O. 21m-L6M 26C-1-2CL-3 (c).

2.1 Identifying Information. Appropriate identifying information, including the revision letter, date, approval, document number, and page number, shall be entered at the bottom of the sheet.

2.2 Example of RAS. For an example of a RAS, reference attachment 2.

2.3 AFSCM/AFLCM 310-1 Data Item Number. Reference S-53-6J.

REQUIREMENTS ALLOCATION SHEET		Functional Design Title & No. _____ or Memorandum & No. of CD _____ (A)		Equipment (E) Identification (E1) or Detail Part or Index or Master Control No. (E2)	PERSONNEL AND TRAINING EQUIPMENT REQUIREMENTS (F)				Personnel Data Requirements (G)
Function Name & No. (B)	Design Requirements (C)	Facility Requirements (D)	Memorandum (E1)	Tasks (F1)	Time Req. (F2)	Perform. Reqs. (F3)	Tool & Test Equip. Req. (F4)	(G)	

Revision _____ Date _____ Approval _____ Document No. _____ Page No. _____ of _____

Figure 9. Requirements Allocation Sheet.

3.0 TRADE STUDY REPORTS. The content of the study report may consist of extracts from designer's notebook, contractors' internal memorandums, minutes of meetings, reductions of presentation charts and formal engineering reports, etc., as long as the study report contains as a minimum the following:

3.1 Identification and Listing of Functional and Technical Design Requirements for Trade-Off. Identify and list the functional and technical design requests which are subject to trade-off. The functional requirement is listed first, and then related technical design requirements are listed. For example, "Determine quantity of loaded propellant" would be a functional requirement and "The propellant loading measurement system must be capable of indicating the quantity of propellant loaded to each tank to an accuracy of ± 35 percent by weight of propellant required" would be a design requirement. Immediately following each listed requirement, a reference shall be made which identifies the source of the requirement if available; this reference shall consist of the title, file number, date, page number, and paragraph number from which the requirement statement was extracted.

3.2 Identification of Possible Design Approaches and Their Design Characteristics. List the possible design approaches and identify significant design characteristics of each design approach. Utilize any weighting provided in the contract work statement. The list would be generated concurrently with the above requirements. Only reasonably attainable design approaches shall be pursued considering technical

capabilities, cost, time schedules, resource limitations, or other constraints as specified in system requirement documentation. For each potential and alternative design approach listed, the contractor shall identify significant applicable characteristics. These characteristics shall relate and be restricted to the attributes of the design approach bearing most directly on its feasibility in relation to the requirements set forth above. The significant characteristics shall reflect predicted impact on such factors as cost, effectiveness, personnel and training requirements, technical orders, schedules, performance, survivability, vulnerability, growth potential, facilities, security (clandestine vulnerability), transportability, procurability, and producibility.

3.3 Comparison Matrix of Design Approaches. Prepare a matrix to compare the design characteristics for each design approach to determine the degree to which the design approaches satisfy the functional and technical design requirements. The objective is to facilitate rapid comparison and evaluation of potential design approaches and to allow preliminary screening out of those design approaches that are inconsistent with the functional and technical design requirements. For submittal purposes, the contractor should attempt to combine the matrix information required with the information required in paragraph 3.2 above. Where applicable, include cost-effectiveness models and cost-analysis data.

3.4 Selection of Design Approach. Select the most promising design approach and provide reasons to substantiate the selection. The rea-

sons given for the selection shall be in the form of schematic diagrams, outline drawings, interface details, functional diagrams, reliability data, maintainability data, statistical inference data, and narrative and any other backup data deemed necessary to support the selection. The reasons shall cover the requirements the selected approach imposes on other areas of the system. The requirements imposed on facilities training, training equipment, human performance, and procedural data shall be determined and entered on the RAS.

3.5 Trade Study Report Index. The contractor shall prepare and maintain a current Trade Study Report index identifying all the trade studies required, the studies completed, and those to be completed.

3.6 Example of Trade Study Report. For an example of a Trade Study Report, reference attachment 2.

3.7 AFSCM/AFLCM 310-1 Data Item Number. Reference S-54-6.1.

4.0 SCHEMATIC BLOCK DIAGRAMS. Schematics shall be prepared to identify (1) intersystem relationships (e.g., a command/control system, interfaces with a strategic weapon system, etc.); (2) intrasystem relationships, including the relationship between constituent elements of a subsystem; e.g., in a communication subsystem interfaces between closed-circuit TV, work station intercom, remote site communication, spacecraft communication, etc.; and (3) subordinate detailed schematics as required to augment (1) and (2) above. The essential characteristic of a schematic is to delineate by symbols (schematic, architectural, electronic, mathematical, structural, mechanical, etc.) the features and relationships of end items, subsystems, components, and parts. Schematic block diagrams are used as the basis for reassembling functional and technical requirements and criteria as established and documented within the Trade Study Reports and RASs, into an integrated set of design requirements comprising a system (including interfaces with other systems), an end item, or a group of related end items.

4.1 Detail Content of Schematic Diagrams. The schematic shall be structured in a manner that will show the functional interfaces and ap-

portionment of requirements between major systems, within the system, between the elements of the system (equipment, personnel, facilities), and between end items; end-to-end and/or closed-loop relationships; and the maintenance or checkout aspects of the proposed design. The amount of detail shown in the schematic diagram will vary depending upon the point in time that the schematic is prepared, the level of information available in the RAS and trade studies, and the level at which hardware requirements are being described (system, major subsystem, major end item, black box, etc.). Sufficient detail shall be shown to illustrate how the design requirements are to be met. As system definition progresses, the schematic diagrams are updated to incorporate new requirements such as maintainability features, self-test capability, read-out indications, monitoring capability, critical pressures, voltages, and other quantitative expressions of system performance.

4.2 Characteristics of Schematic Diagrams. Schematic diagrams shall be prepared in accordance with standard engineering practices, identified and controlled as drawings, and included in AFSCM 375-1 specifications. Reference MIL-STD-7 for definition and examples of electronic and mechanical schematics. Schematic diagrams shall have the following characteristics in common (the diagrams and significant elements within the diagrams shall be uniquely identified to provide the basis):

a. Generating a family of lower level of detail diagrams traceable from the top down or from the bottom up.

b. Collecting and apportioning effective RAS requirements or trade study requirements against applicable system or subsystem equipment.

c. Identification of major intersystem and intrasystem requirements and interrelationships.

4.3 Developing Schematic Diagrams. The basic technique for developing schematic block diagrams is illustrated in figure 10. The first-level schematic diagram shall be complete for the subsystem or subsystems being developed. The schematic shall depict a "closed loop" including a block depiction of intersystem interfaces.

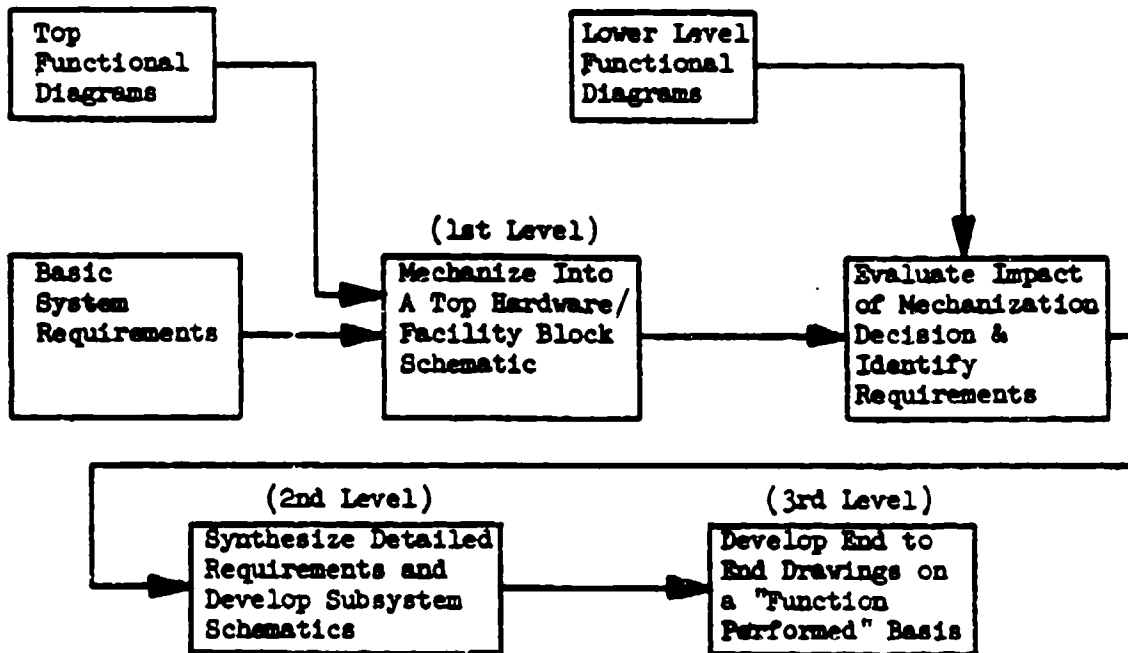

Figure 10. Basic Techniques for Developing Schematic Block Diagrams.

4.3.1 Second-level detail diagrams shall be technical expansions of first-level diagram and will relate contract end items (CEI) within the subsystem. Input and output expansion shall be related to the interfaces expressed in the first-level diagrams.

4.3.2 Third-level detail diagrams shall be organized functionally to define significant end-to-end system logic across all hardware and facility interfaces involved; i.e., power subsystem, launch control, flight sequence, malfunction detection and control, etc. Hardware designators established in first- and second-level detail schematics shall be used against the logic elements to depict interfaces with facilities and equipment and maintain a traceable relationship to the other schematic diagrams. For those functions to be accomplished which are time critical in any system such as computer sequencing, launch control, staging, etc., time shall govern the layout of the drawing; i.e., reading from left to right, one begins with the initial functions and proceeds so that the operations sequence of all applicable hardware is clearly shown.

4.3.3 Third-level detail diagrams shall have significant wave forms, voltage levels, pres-

ures, etc., appropriately noted in the diagrams. Within the preparation cycle, third-level diagrams are prepared prior to or concurrently with preparation of the applicable Part I Detail Specifications and serve to insure end-to-end system integrity at a detailed logic level.

4.4 Example of Schematic Diagram. For examples of schematic diagrams including a family of related schematic diagrams, reference attachment 2.

4.5 AFSCM/AFICM 310-1 Data Item Number. Reference S-55-6.1.

5.0 TIME LINE SHEET. Time line sheets shall be submitted in the format presented in figure 11 in accordance with the following requirements:

Block A—Enter the time-critical functions appearing on functional diagrams. Functions shall be considered time-critical when the estimated time required to perform the function directly affects system design reaction time or down time. Time-critical functions may or may not involve human performance.

Block B—Enter the location where the functions and corresponding tasks (if applicable) are to be performed.

TIME LINE SHEET	FUNCTION A	LOCATION B	TYPE OF MAINTENANCE (IF APPLICABLE) C
SOURCE OF FUNCTION D	FUNCTION AND CORRESPONDING TASKS (IF APPLICABLE) E		TIME () (BAR CHART) F
~~~~~			
~~~~~			

REVISION _____ DATE _____ APPROVAL _____ DOCUMENT NO. _____ PAGE NO. ___ OF ___

Figure 11. Time Line Sheet.

Block C—This entry is applicable only for functions involving maintenance. When applicable, indicate preventive or corrective maintenance.

Column D—Enter the functional diagram drawing number, function block number, and document number of the RAS containing the function. Enter the end item maintenance sheet line item and CEI number whenever the function has been derived from the end item maintenance sheet.

Column E—Enter the functions and corresponding tasks (if applicable) contained on functional diagrams or RASs. Corresponding tasks will not be applicable for all time-critical functions. For time-critical functions involving human performance, identify the Air Force specialty code (AFSC).

Column F—Enter the elapsed time estimated to accomplish functions and corresponding tasks if applicable in seconds, minutes, hours, or days to the first decimal in bar chart manner. The total time in days, hours, minutes, and/or seconds shall be entered at the end of each time bar. Use S=sec, M=min, H=hour, D=day; e.g., 3.5 S means 3.5 seconds. Time estimates shall assume optimum utilization of equipment and personnel.

3.1 Identifying Information. Appropriate identifying information including the revision letter, date, approval, document number, and page number shall be entered at the bottom of the sheet.

3.2 Example of Time Line Sheet. For an example of a time line sheet, reference attachment 2.

5.3 AFSCM/AFLCM 310-1 Data Item Number. Reference S-56-6.1.

6.0 DESIGN SHEET. Design sheets, utilizing source information from the RASs, shall be prepared according to the format shown in figure 12. A design sheet shall be required for each prime equipment CEI, facility CEI, and modified inventory equipment item or engineering critical component, but is not required for identification items, unmodified inventory equipment items, or company standard parts. The contractor may find it necessary to utilize additional internal documentation to supplement the design sheet in order to establish and maintain control of his design effort. Such supplementary documentation will not be included in the Detail Specifications.

Block A—Enter the short-form nomenclature of the contract end item, and abbreviated category of equipment; i.e., AVE, OGE, MGE, AAE, or facility equipment.

Block B—Enter the CEI or critical component code identification detail specification number assigned to the item. These numbers shall be assigned in accordance with the requirements in exhibit X, AFSCM 375-1.

Column C—The information entered on the design sheet shall organize the requirements under the paragraph headings shown in figure 12. Each design sheet shall contain both a "Requirements" section (section 3.0) and a "Quality Assurance Provisions" section (section 4.0), which physically become sections 2 and 4 of Part I Detail Specifications. Where appropriate, indicate the function block number appearing on the functional diagram or the

line item number/master control number appearing on the maintenance sheets which generated the particular requirement. This function source reference shall be entered immediately to the left of the applicable requirement. The subparagraphs of section 3.0, "Requirements," shall contain, in addition to the basic requirements, a description of the contractor's intended design approach which describes how the requirement will be satisfied. The design sheets for prime equipment CEIs and for technical support real property (TSRP) facility CEIs shall comply with the paragraphing requirements in exhibit II, AFSCM 375-1. The design sheets for non-technical support real property shall comply with the paragraphing requirements in exhibit III, AFSCM 375-1. The content requirements for these paragraphs are repeated here for convenience, and in some instances requirements have been expanded to provide additional information. These additions are identified by a vertical line in the margin opposite the addition. For those paragraphs which do not apply to the CEI covered by the design sheet, the title of the paragraph and the comment "N/A" (not applicable) shall be entered.

6.1 Identifying Information. Appropriate identifying information including the revision letter, date, approval, and page number shall be entered at the bottom of the sheet as indicated.

6.2 Example of Design Sheet. For an example of a design sheet, reference attachment 2.

6.3 Paragraph Content Requirements for Prime Equipment and TSRP Facility CEIs Section 3, "Requirements." This section shall contain performance and design requirements for the CEI. This section shall include the functional requirements for the CEI and establish requirements which are suitable for proof during test. This section shall define the CEI and specify design constraints and standards necessary to insure compatibility of the CEI with existing inventory as appropriate. For CEIs which directly support systems, performance and design requirements included are allocated from, identical with, or in recognition of, requirements established by the system specification. Requirements included herein shall be specified in

terms of the CEI itself and not by reference to equipments/facilities with which the CEI must be compatible. Quantitative requirements shall be included within the principle subparagraphs set forth below.

Paragraph 3.1. "Performance." This paragraph shall specify CEI performance in terms of functional requirements. This paragraph shall include requirements which are suitable for proof during test and which establish the capability of the CEI as viewed by the ultimate user. Requirements included herein shall be specified to the level of detail necessary to establish limits for design. Quantitative requirements shall be specified within the two principle subparagraphs included herein.

Paragraph 3.1.1. "Functional Characteristics." This paragraph shall specify, within the subparagraphs included herein, the limiting functional characteristics of the contract end item. This includes performance characteristics which are established by and are the product of analysis as well as performance characteristics which are determined by design. Quantitative requirements shall be specified within the principle subparagraphs included herein. Where fairly complex functional interfaces with other equipment CEIs exist, care should be taken to assure that the required functional characteristics represent requirements indicative of the basic "end result" function of the CEI to be developed, as well as CEI specific input/output characteristics. For example, functional characteristics for an item of OGE required to check out a space vehicle flight control system shall include quantitative identification of the flight control equipment parameters (and required tolerances) to be verified by the OGE as well as the direct input/output signal characteristics of the OGE item itself.

Paragraph 3.1.1.1. "Primary Performance Characteristics." This paragraph shall specify in subparagraphs as appropriate, the primary performance characteristics of the CEI. Requirements specified herein are the product of analysis, stated in terms which do not preselect design solution. "Primary performance characteristics," as used herein, are the limiting performance parameters which must be specified to constrain design when requirements es-

established by primary mission/use of the CEI; e.g., for aircraft, this could include limiting mission profiles, armament, etc.; for an engine this could include thrust, thrust to weight ratio, etc. Requirements included herein shall be stated in quantitative terms, within tolerances, using standard, measurable properties of the CEI itself. Primary performance characteristics shall include power requirements and limitation. Performance characteristics should be specific enough to permit direct progression into detail design effort. For example, in the case of a space vehicle engine, a performance requirement to "provide sufficient thrust to propel the space vehicle" is obviously too general to identify technically meaningful criteria. Rather, specific vehicle dynamic limitations, engine thrust requirements, engine ISP, engine characteristic velocity, etc., are required. Another example would be a requirement for an item to be compatible with a particular type of new propellant. Rather than simply stating that "the item shall be propellant compatible," the specific type of materials to be used in the item in order to insure propellant compatibility may be required.

Paragraph 3.1.1.2, "Secondary Performance Characteristics." This paragraph shall specify in subparagraphs as appropriate, the secondary characteristics of the CEI. Performance characteristics included herein generally presuppose, or are recorded after, a basic design approach has been established, and in this sense are a product of the design process. "Secondary performance characteristics," as used herein, are those parameters which are not necessarily mission/use critical but which must be specified to properly constrain complete design of the CEI; e.g., for an aircraft this could include such things as ground towing speeds, various emergency operation characteristics, etc.; for an engine this could include maximum continuous operating time at emergency rated power, etc. Requirements included herein shall be stated in quantitative terms, with tolerances, using standard, measurable properties of the CEI itself. For complex CEIs, it may be necessary to specify secondary characteristics in terms of functional subsystems to properly control design. For example, considering the air-

craft of an aircraft weapon system as a CEI, it may be necessary to index specific requirements under hydraulics, fuel supply, or direct current electrical system within the aircraft specification. This indexing of requirements is acceptable. This should be accomplished by addressing a separate subparagraph within paragraph 3.1.1.2 to each such subsystem grouping. Care must be exercised when this method of specifying requirements is implemented. It is not the intent to permit the redundant specification of performance characteristics for a given CEI within the specification of a second CEI by identifying the first CEI as a subsystem in the second CEI. For example, considering again an aircraft weapon system, it is not acceptable to specify the characteristics for the engine in the CEI specification for the aircraft. In this case, the aircraft is a CEI and is specified in a separate and distinct specification. The engine is a CEI and is specified in a separate and distinct specification. The specification for the aircraft would list, in paragraph 3.2.2.1, the engine as a CEI installed therein. There would be, in paragraph 3.2.1.2 of both the engine specification and the aircraft specification, an exact callout of the interface between the engine and the airframe or a reference to the interface drawings or other engineering documentation which defines the interface and controls the design of these two CEIs.

Paragraph 3.1.2, "Operability." This paragraph shall specify performance requirements which are general measures of efficiency of the CEI as viewed by the ultimate user. This includes the classic "ilities" such as reliability, maintainability, transportability, survivability, vulnerability, etc., as well as ability to operate in the natural environment, human engineering features, self-checking features, safety features, etc. For CEIs which directly support systems performance requirements included are allocated from, identical with, or in recognition of requirements established by the system specification. To the extent practical, such requirements shall be incorporated herein by reference to the system specification and system documentation. Quantitative requirements shall be specified in subparagraphs to include those stated herein.

Paragraph 3.1.2.1. "Reliability." This paragraph shall specify reliability in quantitative terms, such as measures of availability, mean time to failure, or duration of single downtimes, whichever is appropriate and based on the correct system reliability measure. All measures will include the definition of success (or failure) at a stated confidence level and time period necessary for complete demonstration of reliability requirements.

Paragraph 3.1.2.2. "Maintainability." This paragraph shall specify maintainability requirements for the CEI. Requirements shall be stated in quantitative terms (e.g., mean time to repair, maintenance man-hours per operating hours, etc.), with tolerances or otherwise specified in a manner which can be verified by inspection or demonstrated by test. Also included shall be an explicit description of the maintenance concept established for the item. The determination of the maintenance concept shall consider the nature and frequency of the scheduled and unscheduled maintenance requirements, the capability of military personnel to perform the maintenance tasks, and the cost of physical constraints of providing the necessary maintenance resources. The maintenance concept shall form the basis for justifying acquisition of maintenance resources in range, depth, and configuration. Also indicated shall be the major factors which led to the establishment of the maintenance concept. In addition, maintainability-related characteristics shall be specified in subparagraphs to include the following:

Paragraph 3.1.2.2.1, "Maintenance and Repair Cycles." This paragraph shall specify requirements for maintenance cycles for the CEI; e.g., scheduled organization maintenance every 25 operating hours, depot overhaul every 1,000 operating hours, etc.

Paragraph 3.1.2.2.2, "Service and Access." This paragraph shall specify requirements for ease of service, such as access doors, built-in tools, self-test capability, inspection windows, test jacks, sealed and life warranted bearings, expendable plug-ins, etc. It shall include requirements for capability of the CEI to be drained, discharged, snubbed or otherwise secured, provided with quick disconnects, etc.

It shall specify requirements for the operating status of the equipment during service and/or access; e.g., power on/power off, organizational level remove and replace only, depot level bench repair, etc.

Paragraph 3.1.2.3, "Useful Life." This paragraph shall specify useful life requirements for the CEI. It shall include requirements for shelf-life as well as operating life, and combinations thereof, and shall be compatible with paragraph 3.1.2.2.1 in terminology used to specify useful life. "Useful life" is defined to be the period from time of delivery of the CEI to the procuring agency until its identity is destroyed by classifying it as salvage and/or it is subjected to cannibalization.

Paragraph 3.1.2.4, "Environmental." Standard of natural and dynamic environment which the CEI is to withstand shall be included herein; e.g., wind loading, snow loading, precipitation, ranges in temperature: humidity; atmospheric pressure and density; wind shear; vertical velocities; turbulence; shock; acceleration; noise and vibration; salt spray; sand; dust; penetration and abrasion. The standards for space environment shall be included if appropriate; e.g., energy input from solar radiation, particle mass and energy spectrum, etc. For CEIs which support systems this paragraph shall incorporate the applicable environmental paragraphs of the System Specifications by direct incorporation or by reference. For CEIs which require an artificial environment at all times the controlled environment shall be specified herein. In such cases, this paragraph shall begin with the note "This CEI requires a controlled environment at all times as specified in this paragraph." Constraints of the controlled environment such as cooling air, air pressure, maximum and minimum temperature and humidity, illumination levels, and noise levels.

Paragraph 3.1.2.5, "Transportability." Requirements peculiar to transportability shall be specified herein. Requirements peculiar to "transport mode" specified in paragraph 3.2.1.2, "Detailed interface definition," shall not be redundantly specific in this paragraph. This paragraph shall specify restrictions on the maximum dimensions and weight of the CEI as crated for shipment and shall include pecu-

liar or unusual tie-down requirements imposed by specified methods of transportation. If mobility is a significant feature of this CEI, this paragraph shall include the time, in terms of man-hours and/or elapsed time, allocated to prepare this CEI for transport. This paragraph shall also specify detail requirements for packaging and packing for shipment wherein the packing and packaging methods themselves require development and qualification. Materials handling requirements and, where possible, modes of transportation shall be specified. Transportability criteria and limitations shall be in accordance with AFR 80-18.

Paragraph 3.1.2.6. "Human Performance." Human performance requirements for the CEI shall be specified in this paragraph. For CEIs which directly support systems, this paragraph shall cite the appropriate paragraphs of the system specification which establishes the human performance/human engineering requirements for all systems equipment and incorporate requirements peculiar to this CEI on an "add" or "delete" basis. Include requirements imposed upon the CEI to protect personnel from environments which inhibit human performance.

Paragraph 3.1.2.7. Safety. Requirements for this CEI which must be specified to preclude or limit hazard to personnel and equipment shall be specified. To the extent practical, these requirements shall be imposed by citing established and recognized standards. For CEIs which directly support systems, this paragraph shall cite the appropriate paragraph of the system specification which establishes system safety requirements, amending it on an "add" or "delete" basis for applicability to this CEI. The requirements specified in this section shall not duplicate requirements contained in other sections. Limiting safety characteristics peculiar to this CEI due to hazard in assembly, disassembly, test, transport, storage, operation, and maintenance shall be specified when not provided by standard industrial and Air Force practices and regulations nor provided by the system specification. In addition, "fail safe" and emergency operating restrictions shall be specified. These shall include applicable requirements for interlocks, emergency and

standby circuits, etc., necessary to prevent damage to equipment or injury to personnel, or recovery of the CEI in the event of damage or failure. Requirements shall be specified in the following subparagraphs as appropriate:

3.1.2.7.1 Flight Safety.

3.1.2.7.2 Ground Safety.

3.1.2.7.3 Nuclear Safety.

3.1.2.7.4 Personnel Safety.

3.1.2.7.5 Explosive and/or Ordnance Safety.

Paragraphs 3.2. "CEI Definition." This paragraph shall, in subparagraphs included herein, specify the mechanical and functional relationship of the CEI to other equipments/facilities, identify individual critical components incorporated in the CEI which require individual detail specifications.

Paragraph 3.2.1. "Interface Requirements." This paragraph shall specify, either directly or by reference, requirements imposed on the design of the CEI because of its relationship to other equipment/facilities. This includes schematic arrangement and/or other suitable data which establishes limits for detail design and is the product of system engineering. It also includes detailed interface definition, which is in part the product of design and is developed during the design and development of the CEI. General and descriptive material may be included in basic paragraph 3.2.1. Quantitative requirements shall be included in the subparagraphs included herein. The interface requirements for the CEI shall include not only intrasystem interfaces but, where necessary, any intersystem interface requirements.

Paragraph 3.2.1.1. "Schematic Arrangement." The relationship of the CEI to other equipment/facilities with which it must interface shall be graphically portrayed in this paragraph. This paragraph shall incorporate, in subparagraphs as appropriate, either directly or by reference, a schematic diagram, inboard profile, or equivalent engineering drawing of the CEI. The graphic portrayal of the CEI shall be accomplished to the level of detail necessary to identify the existence of physical interfaces between the CEI and other identified equipments/facilities. The graphic portrayal shall be accomplished to the level of detail neces-

sary to identify the nature of the interface. e.g., mechanical, hydraulic, electrical, communications, etc.

Paragraph 32.12, "Detailed Interface Definition." This paragraph shall specify in subparagraphs as appropriate, in quantitative terms with tolerances, the mechanical and functional relationship of the CEI to interfacing equipment and facilities, to the level of detail necessary to permit detail design. Mechanical relationship of the CEI to interfacing equipment/facilities shall be expressed in terms of dimensions with tolerances of the CEI and related equipment/facilities, at the point of contact, referenced to a common datum plane or point. The means of mechanical connection shall be specified; e.g., bolt circle; marmon clamp, mounting pad, etc. Tolerances shall be established to permit the widest practical latitude in manufacture while maintaining the engineering integrity of the CEI. Functional interfaces shall specify the input/output requirements of the CEI in terms of voltages, pressures, accelerations, limiting temperature ranges, thermal shock limitations, loads, purity requirements for chemicals, etc. They may be the result of direct mechanical interconnect of the CEI to other equipments/facilities, or they may be the result of performance relationship; e.g., autopilot gain and missile bending modes, fire control response and aircraft pitch and roll rates, etc. (In circumstances where there are distinct modes for equipment (e.g., storage mode, operational mode, transport modes, etc.) and the functional interfaces differ with the change in mode, the requirements shall be specified in a manner to be clearly identifiable with each mode.) Tolerances established for functional interfaces shall be as broad as practical to permit use of unsophisticated equipment while maintaining the engineering integrity of the CEI. This paragraph shall incorporate, either directly or by reference, interface drawings and/or other engineering documentation necessary to specify the mechanical and functional interfaces of this CEI with other equipment/facilities.

Paragraph 32.2, "Component Identification." This paragraph shall identify, in the subparagraphs included herein, components or compo-

nent equivalent items incorporated in the CEI which, because of their engineering or supply significance, must be individually specified. This paragraph shall list these items within the categories established and defined in the subparagraphs included. The terms "component" and "property," as used in this paragraph, include both mechanical assemblies such as motors, drives, etc., as well as materials such as hydraulic fluids, fuels, lubricants, bonding agents, etc., and includes tapes and/or EAM decks, containing computer programs, if part of the CEI.

Paragraph 32.21, "Government-Furnished Property List." This paragraph shall list the Government-furnished property which the CEI must be designed to incorporate. The listing shall identify the property by reference to its nomenclature, specification number, and, if appropriate, its CEI number or part number. The term "Government-furnished property," as used herein, includes other CEIs which assemble into a given CEI as well as components and materials which must be incorporated into the design of the CEI. *NOTE:* The GFP list is a product of the definition phase and should be available prior to the design and development portion of the acquisition phase.

Paragraph 32.22, "Engineering Critical Components List." This paragraph shall list the engineering critical components within the CEI. The term "Engineering critical component," as used, is defined to be a component or a component equivalent item which, because of its complexity, the critical impact of its potential failure, anticipated producibility problems, or the qualification of which can be extrapolated to and be accepted as complete qualification for the CEI, must have an individual specification which includes qualification requirements. Engineering critical components are further defined to include all computer programs which are a part of the CEI. Engineering critical components shall be identified by nomenclature, specification number, and, if appropriate, basic part number. Components other than those listed as engineering critical shall be considered individually qualified, for purposes of procurement to support the CEI,

upon acceptance by the procuring agency of the CEI itself as a qualified item.

Paragraph 3.2.3. "Logistics Critical Components List." This paragraph shall list the logistics critical components within the CEI. Logistics critical components or component equivalent items are those items which are selected for multiple source reprourement in support of the CEI, and thus require individual specifications. Logistics critical components shall be identified herein by their nomenclature, specification number, and, if appropriate, part number. *NOTE:* This list of items will, in general, closely parallel the list of vendor-supplied items which the contractor procured from outside sources for assembly into the CEI. The individual specifications for logistics critical items will normally be delivered to the procuring activity at the time of delivery of the qualification data on the CEI itself. The procuring activity will establish requirements for the selection of logistic critical components and for the delivery of specifications for them as part of the design and development contract. This paragraph of the specification shall be amended to incorporate individual logistics critical items as they are identified during the progress of design and development.

Paragraph 3.3. "Design and Construction." This paragraph shall specify design and construction requirements for the CEI. This includes both general design features, e.g., dimensions and weight, as well as detail standards and specification, which must be satisfied by the design and construction of the CEI. To the extent possible, requirements included herein, other than those included in paragraph 3.3.1, shall be specified by reference to established military standards and specifications. For CEIs which directly support systems, the content of subparagraphs included herein, with the exception of paragraph 3.3.1 and subparagraphs thereto, represents recognition of a requirement established within the system specification. The appropriate paragraphs of the system specification shall be referenced herein and amended for applicability to the CEI on an "add" and "delete" basis. Design requirements and features should be specified in sufficient detail to permit direct progression into detail design.

For example, paragraph 3.1.2.1 will require a CEI to meet a specific reliability MTBF requirement. Design and construction requirements should identify the specific design requirements and features that are necessary to meet this MTBF figure (e.g., requirements for selection of high reliability parts, requirements for the adoption of specific circuitry design techniques, etc.). Introductory material may be included in basic paragraph 3.3. Quantitative requirements shall be specified in subparagraphs to include the following:

Paragraph 3.3.1. "General Design Features." This paragraph shall, in subparagraphs as appropriate, specify design features and limiting physical characteristics of the CEI; e.g., size, weight, shape, individual critical dimensions, packaging constraints, etc. Requirements specified herein may be descriptive (e.g., "Access panels shall not be designed to carry primary structural loads") or expressed in quantitative terms (e.g., "Landing gear tract shall not exceed 20 feet"). Requirements to be specified shall normally be verifiable by inspection of the CEI. Arrangement drawings, three-view drawings, list drawings, and equivalent engineering documentation may be incorporated in this paragraph either directly or by reference. Included shall be design features for the controls required by man to operate and maintain the equipment, fault isolation, accessibility, packaging, calibration; e.g., use of test points, taps, disconnects, etc., certification, measuring, and monitoring. Design features for monitoring shall include, in terms of equipment, the displays required by man to operate and maintain the end item, the source of monitoring information (i.e., signals, pressures, malfunctions, etc.) and the displays required by man for monitoring the status of the end item. Included shall be human engineering design criteria applicable to insuring safe, reliable, and efficient operation and maintenance.

Paragraph 3.3.2. "Selection of Specifications and Standards." This paragraph shall specify requirements, criteria, and constraints pertinent to the selection and imposition of Federal, military, and contractor specifications and standards; e.g., "All standards or specifications, other than those established and approved for

use by the Air Force, must be approved by the procuring activity prior to incorporation into the CEI specification." For a list of specifications and standards, see Federal Supply Classification Listing of DOD Standardization Documents. For use of specifications and standards, reference MIL-STD-143.

Paragraph 3.3.3. "Materials, Parts, and Processes." This paragraph specifies requirements for, or prohibits the use of, individual, and types of, materials, parts, and processes. Materials, parts, processes, and special tooling included in this paragraph shall be identified by reference to pertinent specifications.

Paragraph 3.3.4. "Standard and Commercial Parts." This paragraph shall specify requirements pertinent to the use of standard and commercial parts.

Paragraph 3.3.5. "Moisture and Fungus Resistance." Moisture and fungus resistance requirements shall be specified in this paragraph.

Paragraph 3.3.6. "Corrosion of Metal Parts." This paragraph shall specify requirements for the use of protective coatings and other corrosion control requirements. Whenever dissimilar metals are in direct contact, the method for controlling electrolytic corrosion will be specified.

Paragraph 3.3.7. "Interchangeability and Replaceability." This paragraph shall specify requirements for components, assemblies, and parts of the CEI to be interchangeable and replaceable. Entries in this paragraph are for the purpose of establishing a condition of design—not to define the conditions of interchangeability that are required by the assignment of part number. For example, "All fairings and cowlings for the aircraft shall be designed to be readily removed and replaced by quick disconnects and shall be interchangeable within a type, model, series of the aircraft to the extent required by MIL-I-8500." *NOTE:* The relationship of interchangeability to part number identification is defined in MIL-D-70827.

Paragraph 3.3.8. "Workmanship." This paragraph shall specify the general requirements for workmanship incident to fabrication of the CEI. Requirements shall be included herein to make the information available to the

designer so that it will be properly called out on drawings and other engineering documentation. A sample entry might read: "The CEI, including all parts and assemblies, shall be constructed and finished in accordance with MIL-STD- ——. Thoroughness of soldering, wiring, impregnation of coils, marking of parts and assemblies, plating, painting, riveting, machine-screw assemblage, welding, brazing, and freedom of parts from burrs, shall comply with MIL-STD- ——."

Paragraph 3.3.9. "Electromagnetic Interference." This paragraph shall specify requirements related to electromagnetic interference, in terms of the environment which the CEI must accept and the environment which it generates. Included shall be requirements to assure that electromagnetic interference signals are not radiated or conducted which would cause malfunction of other equipment, including electro explosive devices, and that interference is maintained within prescribed tolerances.

Paragraph 3.3.10. "Identification and Marking." This paragraph shall specify the identification and marking requirements for the CEI. "Identification and Marking" entries in this paragraph shall include coding requirements for wiring, plumbing, identification of hazardous conditions, explosive components, etc. A sample entry might read: "All electrical wiring contained in this CEI shall be identified in accordance with MIL-STD- ——."

Paragraph 3.3.11. "Storage." Requirements peculiar to making the CEI storable shall be specified in this paragraph. This shall include, but not be limited to, specification of maximum storage duration, storage environment, restriction pertaining to maintenance while in storage, etc. To the extent that storage environment has been specified in paragraphs 3.1.2.4 and 3.2.1.2, it shall not be redundantly specified in this paragraph.

Section 4. "Quality Assurance Provisions." Requirements for formal verification of the performance, design, and construction of the CEI shall be specified in this paragraph. Formal verification of performance, design, and construction of the CEI shall determine acceptance of design and development engineering, under the terms and conditions of the design and de-

velopment contract. This paragraph shall specify formal verification requirements to a level of detail which:

a. Specifies a verification requirement and method in section 4 for each performance and design requirement in section 3. The methods of verification to be specified herein shall include inspection of the CEI, review of analytical data, demonstrations, test, and review of test data.

b. Specifies each requirement for verification, other than by inspection of the CEI, to the level of detail necessary to clearly establish the scope and accuracy of the test method.

c. Permits ready identification of each verification requirement specified in section 4 with the appropriate performance/design requirement paragraph in section 3.

d. Allocates verification requirements to the subparagraphs included herein. *NOTE:* Formal verification to be specified herein shall not incorporate, either directly or by reference, detail test planning documentation and operating instruction. Requirements specified herein shall be the basis for preparation and validation of such documents.

All test/verification requirements shall be specified within the subparagraphs included herein.

Paragraph 4.1. "Category I Test." The term "Category I test," as used herein, is defined to include all testing of the CEI other than that accomplished during the formal category II and III (or equivalent) system test programs. (Reference para. 4.2 below.) Category I testing is subdivided into the following broad types on the basis of primary reasons for acquiring the test data:

a. *Engineering Test and Evaluation.* An integral part of the development process, oriented primarily to acquire data to support the design and development process; e.g., aircraft structural test, materials test, etc.

b. *Preliminary Qualification Test.* Formal tests oriented primarily to achieve interim acceptance of performance and design characteristics, prior to (1) committing the CEI to manned operation or (2) committing the design to a costly, complete formal qualification program; e.g., preliminary flight rating tests for

engines, preliminary explosive classification tests for ordnance and propellants, sensitivity levels of electroexplosive devices to radio frequency and electromagnetic fields, etc.

c. *Formal Qualification Tests.* Formal tests oriented primarily to satisfy specified requirements of the procuring activity for formal demonstration of performance and design adequacy of the CEI for inventory use.

d. *Reliability Tests and Analyses.* Formal tests and analyses oriented primarily to satisfy specified requirements of the procuring activity for demonstrated reliability. *NOTE:* Data which are included in reliability analyses comes from many sources. "Reliability tests," as used herein, are limited to testing which would not be done except for the need for reliability data.

e. *Engineering Critical Component Qualification.* Formal qualification of identified and specified components/assemblies which are contained in, or a part of, a CEI. It is not the intent to include in this specification all category I test requirements. Only requirements for category I test which satisfy criteria as established by the following paragraphs shall be included herein:

Paragraph 4.1.1. "Engineering Test and Evaluation." Engineering tests which satisfy one or more of the following criteria shall be included herein:

a. Require use of Government test facilities, e.g., verification of requirements specified in paragraph 3.1.2.4.

b. Are intended to be the only source of data to satisfy specific requirements in section 3; e.g., static test of aircraft structure to satisfy requirements in paragraph 3.1.1.1 or paragraph 3.3.1; screen room testing to satisfy requirements in paragraph 3.3.9.

c. Must be accomplished as part of an integrated engineering test program involving other system/inventory equipment; e.g., verification of requirements in paragraph 3.2.1.2. Routine engineering and laboratory tests accomplished in support of design and development, which do not satisfy one or more of the criteria above, shall not be specified herein.

NOTE: Requirements for verification included in the system specification, which are directly

related to requirements specified herein, may be incorporated by reference to avoid redundant establishment of the requirement.

Paragraph 4.1.2. "Preliminary Qualification Tests." This paragraph shall specify only those preliminary qualification tests which require formal recognition by the Air Force: e.g., verification of requirements specified in paragraph 3.1.2.7 prior to the introduction of the CEI into a Government test facility; preliminary flight rating tests on engines prior to first flight or start of formal qualification; etc. Preliminary qualification testing accomplished by the contractor in support of design and development which does not require recognition by the Air Force, other than that it is within the general terms and conditions of contract, shall not be specified. Requirements for preliminary qualifications specified herein shall reference specific requirements in section 3 if these tests are to be the formal basis for the verification that specific requirements of section 3 have been satisfied.

Paragraph 4.1.3. "Formal Qualification Tests." This paragraph shall specify requirements for formal qualification of the CEI to demonstrate or verify that each requirement established in section 3 has been satisfied. This paragraph shall, in subparagraphs as appropriate, specify the requirement and method of verification for each requirement specified in section 3, with the following exceptions:

a. The requirement in section 3 has been identified with, and verification that it has been satisfied has been accomplished by, one of the tests included in paragraphs 4.1.1 and 4.1.2 above.

b. The requirement in section 3 is peculiar to paragraph 3.1.2.1. Verification of reliability requirements shall be treated in paragraph 4.1.4, to follow.

c. The requirement in section 3 is peculiar to category II type system testing and will be identified in paragraph 4.2 to follow.

Each requirement shall be verified by inspection, review of analytical data, demonstration, or test and review of test data, or combinations of these. This paragraph may contain a subparagraph for each of the principal methods of verification and may specify the requirements

of section 3 to be verified by the method. For example:

*"4.1.3 Formal Qualification Test—*The following subparagraphs specify the requirements for and methods of formally verifying that each requirement in section 3 has been satisfied:

*"4.1.3.1 Inspection—*The following requirements of section 3 shall be verified by an inspection of the CEI at time and place of qualification testing:

"Paragraph 3.1.2.2.2, 'Service and Access'

"Paragraph 3.3.1, 'General Design Features' (the following listed dimensional features only):

"Paragraph 3.2.1.1, 'Schematic Arrangement'

"Paragraph 3.3.3, 'Materials, Parts, and Processes'

"Paragraph 3.3.4, 'Standard and Commercial Parts'

"Paragraph 3.3.7, 'Interchangeability and Replaceability'

"Paragraph 3.3.8, 'Workmanship'

"Paragraph 3.3.10, 'Identification and Marking,' etc.

*"4.1.3.2 Analyzes—*The following requirements of section 3 shall be verified by review of analytical data:

"Paragraph 3.1.2.2, 'Maintainability.' To include a review of the maintenance portion of the system engineering documentation and contractor internal documentation analyzing the anticipated modes of failure of the CEI.

"Paragraph 3.1.2.3, 'Useful Life.' To include analysis of contractor experience data to date of review, vendor historical and analytical summaries, as well as stress analyses accomplished on critical assemblies, etc.

*"4.1.3.3 Demonstrations—*The following requirements of section 3 shall be verified by demonstrations:

"Paragraph 3.1.2.2.2, 'Service and Access.' The demonstration shall include one complete maintenance overhaul cycle of the CEI as required by technical manuals.

"Paragraph 3.1.2.5, 'Transportability.' The demonstration shall include a complete preparation for movement, and movement of

the CEI. This demonstration shall be accomplished as part of the actual movement of the CEI to the environmental test facility.

4.1.3.4 Tests—The following requirements in section 3 shall be verified during the formal qualification test program.

“Paragraph 3.1.1, ‘Functional Characteristics’

“Paragraph 3.1.2.2, ‘Maintainability’

“Paragraph 3.1.2.4, ‘Environmental’

“Paragraph 3.3.9, ‘Electromagnetic Interference,’ etc.

“The formal qualification test program shall include three units of the CEI. One shall undergo continuous test in the engineering test laboratory. It shall be operated continuously for a period of 3 months while being used as required by paragraph 3.1.1, etc. The second unit shall undergo screen room testing, then be transferred to shaketable testing, etc.”

Paragraph 4.1.4, “Reliability Test and Analyses.” Requirements for analyses to verify requirements of paragraph 3.1.2.1 which have been satisfied shall be specified herein. This shall include the sources of data, volume of data, assumptions basic to the validity of raw data input, and analytical method. Requirements for testing specifically and solely to acquire reliability data shall be included herein, to the level of detail necessary to establish the scope and accuracy of the reliability data to be acquired, and the scope of the test program.

Paragraph 4.1.5, “Engineering Critical Component Qualification.” This paragraph shall identify, for each of the engineering critical components listed in paragraph 3.2.2.2, the specification which contains its formal qualification test requirements.

Paragraph 4.2, “Category II Test Program.” For CEIs which directly support systems, this paragraph shall identify requirements specified in section 3 which cannot be verified until the CEI is assembled into or used with other system equipment. Verification that the requirement has been satisfied must be listed as a category II test requirement. For nonsystem equipment, verification that all requirements in section 3 have been satisfied must be accomplished within the testing identified in paragraph 4.1 above.

6.4 Paragraph Content Requirements for NSRP Facility CEI's Section 3, “Requirements.” This section shall contain performance and design requirements for the facility. This section shall include the functional requirements for the facility and establish requirements which are measures of the efficiency/effectiveness of the facility as viewed by the ultimate user. This section shall define the facility, identify critical interfaces, and specify design constraints and standards necessary to insure compatibility with existing or contemplated hardware. For integrated facilities, performance and design requirements included are allocated from, identical with, or in recognition of requirements established by the system specification. Requirements included shall be specified in terms of the facility itself and not by reference to equipment with which the facility must be compatible. The following represents an outline of specific information required in this FCEI Specification (however, it is not to be construed as preventing the addition of such information as may be required to properly identify the peculiar system facility requirements):

Section 3.1, “General Concept.” This section shall describe in detail the use to which the facility will be put: describe the flow of personnel, material, and functions to be performed in the facility, including time elements, etc.; identify the maintenance and logistic policies to be employed; establish design-useful life requirements; establish facility self-sufficiency requirements and special facility survival requirements.

Section 3.2, “Siting and Layout”:

a. Provide an area plan showing location of facility with respect to general area.

b. Provide a detailed site plan showing:

(1) Access requirements, special width requirements.

(2) Required relationships between outside elements.

(3) Clearances.

(4) Parking, loading, required set-backs, paving, walks, drainage, etc.

(5) Existing contours.

(6) Quantity-distance separation requirements for explosive facilities and operations.

(7) Blockouts, elevations, anchor belts, or other provisions for equipment.

Section 3.3. "General Criteria":

a. Civil:

- (1) Axle or wheel loads on roads.
- (2) Special lane width of roads.
- (3) Turn and weight provisions for special vehicles.
- (4) Jack loads, transfer requirements.
- (5) Parking (number of vehicles).
- (6) Grades on roads, type pavement (flexible or rigid), walks, type (flexible or rigid).
- (7) Special water and sewage requirements. Quantity and nature of water and sewage, if special.
- (8) Special fire protection requirements (exterior).
- (9) Fencing and security.
- (10) Location and types of existing utilities, if any (water, gas, sewer, electrical, storm drainage).

b. Architectural:

- (1) Personnel occupancy, types, hours per day.
- (2) Designation of use of areas within facility, partition layout, hazardous areas, and special treatment areas.
- (3) Types of special doors required.
- (4) Floor level requirements; floor drainage.
- (5) Window requirements, if any.
- (6) Controlling dimension requirements.
- (7) Clear ceiling heights.
- (8) Exterior architectural treatment (concrete, masonry, brick, etc.). Indicate whether treatment is to match existing, if applicable.
- (9) USAF explosive safety requirements for construction.

c. Structural:

- (1) Crane and hoist location and loads; control requirements.
- (2) Floor and roof loads, special loads, seismic loads, wind loads, and clear interior heights.
- (3) Clear span and column-free areas.
- (4) Blast loads; shielding requirements.
- (5) Personnel ladders; elevators.
- (6) Transfer piers; dock loads.

(7) General configuration of building; number of stories.

(8) Barricades and shielding for explosive blast areas.

d. Mechanical:

- (1) Interior potable water.
- (2) Environment limits; temperature, humidity, and ventilation.
- (3) Compressed air.
- (4) Fire protection.
- (5) Vibration and acoustical requirements.
- (6) Equipment cooling requirements.

e. Electrical:

- (1) Power requirements—type and magnitude.
- (2) Light intensities.
- (3) Communications requirements.
- (4) Grounding.

f. Equipment (provide layout and list each piece of equipment):

- (1) Equipment name.
- (2) Units required (number).
- (3) Purpose of equipment.
- (4) Size of equipment (governing dimensions, weight).
- (5) Power requirements—heat gain, BTUs per hour, type cooling, in-out temperatures, and relative humidities.
- (6) Minimum access requirements—front, back, and sides.

Section 4. "Quality Assurance Provisions." This section shall identify special testing, quality control procedures, and/or performance verification requirements necessary to insure the adequacy of special or unique facility provisions. *NOTE:* Standard facility verification requirements shall not be included herein.

6.5 Paragraph Content for Trainer Contract End Items:

6.5.1 There is no change from content described in 6.3 except as follows:

Paragraph 3.1.1.1, "Primary Performance Characteristics." This paragraph shall include:

s. A summary of the training tasks to completely qualify Air Force personnel to operate and maintain the system equipment represented by the trainer, including identification

and locations of operational equipment upon which these tasks will be performed in the operational situation. This summary should reflect both organizational and field levels of operation and maintenance.

b. A list of the training tasks identified in the preceding paragraph which the trainer will support, accompanied by a statement of the method by which the trainer will support the tasks listed (i.e., method by which malfunction can be inserted in the trainer system to practice isolation of malfunctions or emergency operating procedures).

c. A statement of limitations inherent in the trainer design which may preclude adequate support of the total operations procedures and field maintenance procedures (i.e., bench repair of malfunctioned electronic chassis).

d. Other trainers—Reference to other trainers/training equipment or operational equipment to be used jointly with or to supplement the trainer to cover the training tasks and limitations described in paragraphs 3.1.1.1 a and b above.

e. Simultaneous training—Identification of the tasks covered by this trainer requiring simultaneous student participation at different work stations. Training task numbers from paragraph 3.1.1.1 b above should be used.

f. Class Size—The maximum number of students that may be efficiently trained simultaneously with this trainer in (1) demonstration with observers and (2) student participation.

g. Fault Insertion—The types of faults to be inserted, the methods of generating such faults, where they will be inserted in the system, source of information identifying the faults to be inserted, and a description of the provisions in trainer design for including additional faults not identifiable during trainer design.

h. Special Features—A description of the special features of the trainer which make it more flexible as a training device than the operational hardware which it reflects—i.e., the capability of controlling functions that are automatically sequenced in the operational equipment; simulation of system equipment to provide a capability of continuously operating/recycling in a training situation.

Paragraph 3.1.2.1. "Reliability." For trainers this paragraph will reflect a requirement for a specified period of continuous operation and use in terms of "turned on" time in hours and number of training cycles. This requirement must be derived as a function of the scheduled course and class load, organic maintenance capability of the user, and desired useful life of the trainer.

Paragraph 3.1.2.5. "Transportability." For a trainer, state whether it is to be permanently installed at a specific location, road mobile, railroad mobile, or air mobile.

Paragraph 3.2.2. "Component Identification." Add the following: "This paragraph shall also list the major items of equipment required to operate with a trainer in an instructional situation by the following categories:

"a. Contractor-furnished system operational equipment.

"b. Government-furnished equipment (by expected source)."

Paragraph 3.2.2.2. "Engineering Critical Components List." Add the following: "Computer programs included in this list for trainers will cite the specific system functional data documents from which they were derived."

Paragraph 3.3.1. "General Design Features." Add the following:

"3.3.1.1 Trainer Description." A description of the trainer identifying the major units and their relationship to each other and to the represented operational equipment. These relationships shall be stated in terms of the signals to be received by the terminal equipment and how such signals will be generated or simulated in the trainer. This text shall be supported by appropriate data flow diagrams of these signals, indicating where provision shall be made for fault insertion and sequence interruption.

"3.3.1.2 Related Functional Simulation." A description of how operational equipment or functions not physically represented in the trainer will be simulated. The degree of simulation or visual presentations, control positions, and physical configuration of the operational equipment being reflected in the trainer shall be specified.

DESIGN SHEET	NOMENCLATURE (A)	CEI NO. OR CRITICAL COMPONENT CODE IDENTIFICATION DETAIL SPEC NO. _____ (B)
REQUIREMENTS FOR DESIGN AND TEST (C)		
<p>3 REQUIREMENTS</p> <p>3.1 PERFORMANCE</p> <p>3.1.1 FUNCTIONAL CHARACTERISTICS</p> <p>3.1.1.1 PRIMARY PERFORMANCE CHARACTERISTICS</p> <p>3.1.1.2 SECONDARY PERFORMANCE CHARACTERISTICS</p> <p>3.1.2 OPERABILITY</p> <p>3.1.2.1 RELIABILITY</p> <p>3.1.2.2 MAINTAINABILITY</p> <p>3.1.2.3 USEFUL LIFE</p> <p>3.1.2.4 ENVIRONMENT</p> <p>3.1.2.5 TRANSPORTABILITY</p> <p>3.1.2.6 HUMAN PERFORMANCE</p> <p>3.1.2.7 SAFETY</p> <p>3.2 CEI DEFINITION</p> <p>3.2.1 INTERFACE REQUIREMENTS</p> <p>3.2.1.1 SCHEMATIC ARRANGEMENT</p> <p>3.2.1.2 DETAILED INTERFACE DEFINITION</p> <p>3.2.2 COMPONENT IDENTIFICATION</p> <p>3.2.2.1 GOVT-FURNISHED PROPERTY LIST</p> <p>3.2.2.2 ENGINEERING CRITICAL COMPONENTS LIST</p> <p>3.2.2.3 LOGISTICS CRITICAL COMPONENTS LIST</p> <p>3.3 DESIGN AND CONSTRUCTION</p> <p>3.3.1 GENERAL DESIGN FEATURES</p> <p>3.3.2 SELECTION OF SPECIFICATIONS AND STANDARDS</p> <p>3.3.3 MATERIALS, PARTS AND PROCESSES</p> <p>3.3.4 STANDARD AND COMMERCIAL PARTS</p> <p>3.3.5 MOISTURE AND FUNGUS RESISTANCE</p> <p>3.3.6 CORROSION OF METAL PARTS</p> <p>3.3.7 INTERCHANGEABILITY AND REPLACEABILITY</p> <p>3.3.8 WORKMANSHIP</p> <p>3.3.9 ELECTROMAGNETIC INTERFERENCE</p> <p>3.3.10 IDENTIFICATION AND MARKING</p> <p>3.3.11 STORAGE</p> <p>4 QUALITY ASSURANCE PROVISIONS</p> <p>4.1 CATEGORY I TEST</p> <p>4.1.1 ENGINEERING TEST AND EVALUATION</p> <p>4.1.2 PRELIMINARY QUALIFICATION TESTS</p> <p>4.1.2.1 FORMAL QUALIFICATION TESTS</p> <p>4.1.2.1.1 INSPECTION</p> <p>4.1.2.1.2 ANALYSES</p> <p>4.1.2.1.3 DEMONSTRATIONS</p> <p>4.1.2.1.4 TESTS</p> <p>4.1.4 RELIABILITY TESTS AND ANALYSES</p> <p>4.1.5 ENGINEERING CRITICAL COMPONENT QUALIFICATION</p> <p>4.2 CATEGORY II SYSTEM TEST PROGRAM</p> <p>NOTE: FOR YSRP FACILITY CEI DESIGN SHEETS, SECTIONS 3.0 AND 4 SHALL BE AS SPECIFIED ABOVE FOR PRIME EQUIPMENT CEI DESIGN SHEETS. FOR YSRP FACILITY CEI DESIGN SHEETS THE FOLLOWING OUTLINE (REFERENCE AFSCM 375-1, EXHIBIT III) SHALL BE USED.</p> <p style="margin-left: 40px;">3 REQUIREMENTS</p> <p style="margin-left: 40px;">3.1 GENERAL CONCEPT</p> <p style="margin-left: 40px;">3.2 SITING AND LAYOUT</p> <p style="margin-left: 40px;">3.3 GENERAL CRITERIA</p> <p style="margin-left: 40px;">4 QUALITY ASSURANCE PROVISIONS</p>		

REVISION _____ APPROVAL _____ DATE _____ PAGE NO. _____ OF _____

Figure 13. Design Sheet.

3.3.1.3 Human Engineering. For trainers, identification of areas where operating, maintenance, or instruction station difficulties have been minimized through human engineering practices as defined in MIL-STD-803A, "Human Engineering Design Criteria for Aerospace Systems and Equipment."

3.3.1.4 Modification. Description of the design features of the trainer which will allow for modification of trainer system or subsystems to later system model series.

3.3.1.5 Ease of Modification. Careful consideration shall be given to possible future changes in the operational equipment, and sufficient design flexibility shall be incorporated in the trainer to permit rapid and inexpensive modifications when such changes occur. Possible future attachments to the trainer shall be considered which will increase its training value in terms of an expanded operational mission. When applicable, the design shall provide for rapid and inexpensive connection of the device to related equipment so as to accomplish more advanced training or to provide integrated crew training as well as individual training.

3.3.1.6 Simplicity. System training objectives shall be analyzed to determine the minimum equipment complexity needed for essential training functions. This analysis shall consider such factors as (1) the degree of physical simulation required for optimum transfer of training, (2) the extent to which controls and displays should be incorporated as operable equipment, and (3) the feasibility of automating the equipment or certain of its features; e.g., incorporating automatic functions to relieve instructor and operator personnel of routine manual operations."

Paragraph 3.3.9. "Electromagnetic Interference." Add the following: "Particular attention should be accorded the problems which may arise from the use of different transmitting frequencies for the training situation than those used in the operational situation. Additionally, the specific requirements regarding physical location of the trainer on a base should be stated so as to preclude unnecessary interference with normal communications of the local populace."

Paragraph 4.1.4 "Reliability Test and Analysis." Add the following: "Reliability testing on

system equipment used as training equipment is not normally required. However, an analysis based on existing reliability data on weapon system parts and other components is necessary. This analysis shall be sufficient to substantiate the requirements of paragraph 3.1.2.1."

Paragraph 4.2 "Category II Test Program." Add the following: "An acceptance inspection covering the functional characteristics and suitability shall be outlined defining the tests to be used in determining the adequacy of the trainer to accomplish the general and specific objectives of section 3. This outline shall describe the criteria, methods, materials, and personnel. Further procedural checklists developed for use with the trainer will be compatible with and representative of the checklist and procedures developed for the system which this trainer represents. The objectives of this acceptance inspection are to determine:

"a. The functional adequacy and performance capability of the equipment in relation to its planned use in the training mission.

"b. Design adequacy in terms of layout, recording devices, tolerances, limits of operation, proficiency measures, and related characteristics.

"c. The adequacy of installation, calibration, and maintenance procedures, including training equipment parts consumption.

"d. The suitability of the equipment as reflected in the responses of representative students, instructors, and operators."

6.6 AFSCM/AFLCM 310-1 Data Item Number. Reference S-57-6.1.

7.0 FACILITY INTERFACE SHEETS. The facility interface sheet (fis) shall be submitted in the format illustrated in figure 13 and prepared in accordance with the following requirements:

Block A—Nomenclature and CEI Number. Enter the nomenclature and identification of the equipment (AVE, OGE, RPIE, etc.) for which the facility requirements are being identified.

Block B—Originator. Enter the identification of the contractor or other agency originating the sheet and the equipment identified in block A.

Block C—Site Effectivity. Enter the site, location, or general area of use of the equipment

identified in block A. If the equipment location is fixed within a particular facility area, this area should be identified, along with the major location. If the equipment is portable, state this and identify general area of use; e.g., "Portable equipment, missile ready and maintenance areas, all squadrons." Amplify the location information as necessary in the specific requirements.

Block D—Reference Functions. Enter the function numbers for which the equipment identified in block A is used, and the appropriate RAS reference numbers where the functions are documented.

Block E—Environmental Requirements. Using the checklist at the top of the column, enter the requirements data for each checklist heading using the numeric designation from the checklist. These entries will be derived from the appropriate sections of the design sheet, e.g., environmental, human performance, safety, etc. Entries will be as brief as possible, stressing quantitative values, but complete enough to fully portray the environmental requirements and effects of the equipment as outlined in the following description of each heading. When the checklist heading is not applicable to the equipment identified in block A, indicate this with an "N/A" entry for the corresponding checklist heading number.

(1) *Vibration/Shock/Acoustic Level*—The maximum limits that the equipment should be subjected to by the facility environment will be stated in qualitative terms. Likewise, if the equipment itself creates vibration, shock, or acoustics that will influence the facility environment or surrounding equipment, this will be stated and the quantities entered.

(2) *Temperature and Humidity*—Enter the temperature and humidity extremes (high and low) that must be provided for the equipment by the facility environment.

(3) *Forced Ventilation/Air Changes*—If equipment requires forced ventilation from facility air supply, state requirements in terms of minimum and maximum temperatures and humidity, and flow in CFM. Air change requirements in facility controlled spaces will be stated in air changes per hour.

(4) *Illumination*—State maximum or minimum illumination levels to be provided on console or work surfaces of equipment in foot candles, for each surface of interest.

(5) *Personal Occupancy*—State number of personnel required for normal operation and their proximity to equipment. If special provision must be made for significant numbers of maintenance personnel, so state.

(6) *Electro-magnetic Interference/Compatibility*—Enter tolerance limits of equipment for radiated electro-magnetic interference (EMI) in terms of frequency and power level and for powerline ground interference potentials in terms of volts, etc., and frequency. If the equipment itself produces radiation or powerline harmonics that will affect the facility environment, then these must be stated.

(7) *Contamination Level*—Enter any constraints on facility environment imposed by contaminant-level tolerance of equipment: e.g., "Air in room shall contain less than 100 particles .5 microns or greater per 100 cubic feet of air." Also, if equipment releases contaminants or has potential of creating contamination hazards, these limits will be stated.

(8) *Hazards/Safety*—Enter qualitative and quantitative values of hazards or safety to personnel and/or the facility imposed by installation of the equipment in the facility environment, not covered under other headings.

(9) *Heat Rejection Rate*—If equipment releases heat to facility environment, not covered under other headings, so state.

(10) *Critical Time Factors*—Enter any time critical operating or accessibility considerations that will affect facility environment: e.g., "Equipment must operate for a maximum of 28 hours continuously every 48 hours without access for service or degradation of facility environment."

(11) *Other Special Environmental Requirements*—Enter any other special environmental considerations not covered by one of the above headings.

Block F—Interface Design Requirements. In a manner similar to block E, this block and checklist will be used to state the design requirements data for the physical interfaces between the equipment identified in block A and the ap-

propriate facilities. The data for these entries will be derived from the applicable sections of the design sheet to satisfy the following check-list descriptions.

(1) *Envelope and Weight*—Enter the physical envelope dimensions of the equipment and its total installed weight. If special fixtures are required for its movement or installation, enter these weight and size parameters also.

(2) *Mounting Provisions*—Enter method location and controlling dimensions for fixed equipment: e.g., "Wall-mounted in silo with center line 3 feet above level 14; floor-bolted on 3' x 6' pad within 8 feet radius of umbilical tower base"; etc. Portable equipment will be indicated as portable, bench rest, portable, caster mounted; etc.

(3) *Electric Power*—State power required to operate equipment in terms of volts, watts, frequency, power factor, stability, and tolerances: e.g., "480 ± 4 volts, 1.5 kw., .9 p.f. 60 ± 0.5 c.p.s." State connection requirements: i.e., permanently wired, special connectors, source fused, etc. If electrical load is large (500 w. or greater) and cyclical in nature, state time variant nature related to system functions and time.

(4) *Electrical Grounding*—State grounding requirements in terms of ohms, connection points, wire size, type, method of connection: i.e., solder, lugs, etc.

(5) *Water and Gas Service*—Enter requirements for water, gas, or other fluids to be supplied by facilities in terms of minimum-maximum pressures, flow rates, purity requirements, minimum-maximum temperatures and water hardness-mineral content.

(6) *Access*—Enter any controlled dimension requirements, special platforms, etc., required to operate or maintain the equipment in its installed configuration: e.g., "Clear access required behind console 72" deep by 20" wide by 84" high for removal of mercury column."

(7) *Position/Location*—Enter detailed position, orientation, or location information where critical to operation of equipment; e.g., "Console face must be within 10 feet maximum and 6 feet minimum of display panel DS-10 with top rear of console toward panel."

(8) *Handling Provisions*—Enter requirements imposed on facility to handle or move

portable equipment into its location of use: e.g., "Provide elevator or other hoisting means to place test set within 4 feet vertically of elevation 41 and within 10 feet horizontally of missile center line."

(9) *Fire/Hazard Provisions*—Enter specific location or configuration requirements for facility protective or removal devices: e.g., "A minimum of 800 GPM water deluge will be provided distributed evenly over top and four sides of equipment enclosure, to be actuated on command of controller. Ninety-nine percent containment and removal in enclosed drain required for toxic deluge products."

(10) *Other Special Interface Considerations*—Any special interface requirements not covered by the above will be entered under this category. Include critical time envelopes not covered under other headings.

It is emphasized that the information entered in block F as instructed above does not replace or substitute for interface control drawings. Depending on the point in the system engineering process, this sheet may be the input to the development of the definitive interface control drawings, at which time the drawings become a supplement to the FIS to graphically illustrate and detail the physical interface. Where such a drawing has been issued, the appropriate heading entry will refer to this drawing and the drawing appended to the facility interface sheet.

Facility interface sheet entries are subject to iteration with the system engineering process. Entries will always be made as completely as possible. Where certain information is recognized as a requirement but simply not available, the entry will indicate the missing but recognized requirement with a blank: e.g., "Required electric power will be 220 ± 18v., 60 ± 10 c.p.s. 30 - k.w. at - p.f." Subsequent updating of the format will continue by the originator until all requirements are stated and blanks filled in. Where a reasonable estimate can be established, it will be entered, followed by the designation "(est)." When verified, the "(est)" designation will be removed by revision to the facility interface sheet.

7.1 Identifying information. Appropriate identifying information including the revision letter, date, approval, document number, and

FACILITY INTERFACE SHEET		A. REGULATIONS AND CR MESSAGES		B. REFERENCE FUNCTION		C. SITE EFFECTIVITY		D. INTERFACE SPECIAL REQUIREMENTS	
		SYMBOL CATEGORY				SYMBOL CATEGORY			
(1) VIBRATION / SHOCK / ACOUSTIC LEVEL	(4) ELECTROMAGNETIC INTERFERENCE COMPATIBILITY	(1) DEVELOPE AND BEIGN	(1) VIBRATION / SHOCK / ACOUSTIC LEVEL	(1) DEVELOPE AND BEIGN	(1) VIBRATION / SHOCK / ACOUSTIC LEVEL	(1) DEVELOPE AND BEIGN	(1) DEVELOPE AND BEIGN	(1) DEVELOPE AND BEIGN	(1) DEVELOPE AND BEIGN
(2) TEMPERATURE AND HUMIDITY	(7) CONTAMINATION LEVEL	(2) UNDERFLOOR EQUIPMENT	(2) TEMPERATURE AND HUMIDITY	(2) UNDERFLOOR EQUIPMENT	(2) TEMPERATURE AND HUMIDITY	(2) UNDERFLOOR EQUIPMENT	(2) TEMPERATURE AND HUMIDITY	(2) UNDERFLOOR EQUIPMENT	(2) TEMPERATURE AND HUMIDITY
(3) PRESSURE VENTILATION / AIR CHANGES	(8) HAZARDOUS MATERIALS	(3) ELECTRICAL POWER	(3) PRESSURE VENTILATION / AIR CHANGES	(3) ELECTRICAL POWER	(3) PRESSURE VENTILATION / AIR CHANGES	(3) ELECTRICAL POWER	(3) PRESSURE VENTILATION / AIR CHANGES	(3) ELECTRICAL POWER	(3) PRESSURE VENTILATION / AIR CHANGES
(4) ILLUMINATION	(9) SILENT ELECTRONIC DATA	(4) ELECTRICAL GROUNDING	(4) ILLUMINATION	(4) ELECTRICAL GROUNDING	(4) ILLUMINATION	(4) ELECTRICAL GROUNDING	(4) ILLUMINATION	(4) ELECTRICAL GROUNDING	(4) ILLUMINATION
(5) PRESSURE OCCUPANCY	(10) CRITICAL TIME FACTORS	(5) WATER AND GAS SERVICE	(5) PRESSURE OCCUPANCY	(5) WATER AND GAS SERVICE	(5) PRESSURE OCCUPANCY	(5) WATER AND GAS SERVICE	(5) PRESSURE OCCUPANCY	(5) WATER AND GAS SERVICE	(5) PRESSURE OCCUPANCY
	(11) OTHER SPECIAL REQUIREMENTS								

DRAWN _____ DATE _____ APPROVAL _____ SECURITY NO _____
 _____ PAGE _____ OF _____

Figure 13. Facility Interface Sheet.

page number shall be entered at the bottom of the sheet. Pages will be numbered consecutively starting from one for each end item, and not consecutively by submittal or system.

7.2 Example of Facility Interface Sheet. For an example of a completed facility interface sheet, reference attachment 2.

7.3 AFSCM/AFLCM 310-1 Data Item Number. Reference S-38-8.1.

8.0 END ITEM MAINTENANCE SHEET. Detail requirements for manually completing end item maintenance sheets are specified herein. End item maintenance sheets shall be submitted in the format presented in figure 14 in accordance with the following requirements:

Column A—Enter the CEI number, inventory equipment or CEI requirement specification number of AVE, OGE, MGE, or AAE on which the study is being made.

Column B—Enter the letter "A" for addition, "C" for change, and "D" for deletion, as applicable to column A. A number following the letter shall be entered to indicate the numbered change or addition it is; e.g., "C6" would be change 6, and "A2" would be addition 2.

Column C—Enter the relative position of the item within the group assembly hardware breakdown starting with indenture "A" identifying the highest level of a given item of hardware to be produced or furnished as an entity by the Government, and progressing in order through B, C, D, etc., in accordance with the mechanical disassembly relationship of the parts being analyzed. For example, B is a subassembly of A; C is a subassembly of B; etc. The breakdown shall be continued down to the lowest maintenance significant item. Entries in this column shall indicate the order of disassembly as described in MIL-M-8910 of the item under analysis. In the case of communications, electronic, or meteorology equipment, MIL-T-9041 is the guiding specification.

Column D—Enter identification (see MIL-M-8910) of subsystem or equipment being analyzed. For organizational and field levels of maintenance, repairable items will be listed by basic part number and any identifying dash numbers; nonrepairable or overhaul items will be listed by the basic part number only. The part number shall be updated as necessary to

reflect the official part number used by the Air Force for procurement of the item as soon as available. Normal evolution of system design may create instances where interim retrofit configurations may be identified in this column. If this occurs, the authorizing ECP and/or SCN number, together with a retrofit complete date, will be entered parenthetically below the noun and name entry.

Column E—Subsequent to design requirements baseline establishment, ECPs will generate a need for specific effectivity identification. The specific effectivity will be noted in this column opposite the applicable equipment entry. The purpose of the entry in this column is to identify the end item of which the items being analyzed are a part. The serial number of the next higher end item must be used because of hardware differences that might exist within a given part number. Where configuration differences exist within the next higher end item that would affect the usability of the item under analysis, insert the lowest and highest serial number of the next higher end item. In cases where the specific item under analysis is usable on all serial numbers of the higher end item, insert the lowest serial number and "and subsequent," etc. End items for which there is no higher end item will reflect only their serial numbers.

Column F—Identifies the configuration of equipment at the time the maintenance function in column G is accomplished. Only one of these columns shall be filled out for a maintenance function; no entry shall be made if this is a "whenever" function.

Column F1—System Installed. Enter an "x" to indicate that the preventive corrective maintenance functions required to keep the system operating are being performed while the equipment is in its operating configuration. An entry indicates that the maintenance functions are required to keep the system operating or return it to operable status.

Column F2—Subsystem Assembled (or Primary Spare). Enter an "x" to note repairable equipment that is required as a spare at user level. This column applies only to repairable equipment that can be removed and installed (usually preissue items), e.g., electronic

drawers, cooling unit assemblies. An entry indicates that the maintenance functions are performed on a subsystem or module that has been removed from the system but not disassembled.

Column F3—Subsystem Disassembled (or Secondary Spare). Enter an "x" to not reparable equipment that is required as a spare. This column applies to reparable equipment that is removed and installed to correct a malfunction on equipment in an assembled subsystem or primary spare; e.g., power supply modules, computer elements and valves.

*Column G—*Enter identification of the maintenance functions required on equipment listed under column D. Subcolumns 1 through 14 identify basic maintenance functions which may apply to the equipment entered in column D. Only one function entry shall be made per line item. As each entry is made in column G, the preventive and corrective maintenance frequency of that function shall be entered in the appropriate subcolumn of column H. Each major assembly shall be analyzed as a complete assembly for maintenance functions and maintenance frequency (1) in a system installed, (2) for subsystem-assembled configuration, and (3) as an end item, whether it is primary spare or a secondary spare. After analysis as an end item, the major assembly will be broken down in a logical order of disassembly on successive sheets. The lower indenture items identified thereon shall be subject to analysis as performed on higher level equipment.

Subcolumn G1—TEST identifies the requirement to isolate the failures on malfunctioned equipment. Enter letter "T" for "test" in subcolumn G1, when applicable. **CHECKOUT** identifies the requirements to establish or ascertain whether the item is properly functioning. Enter "C" for "checkout" in subcolumn G1 when applicable.

Subcolumn G2—CALIBRATE identifies the requirements to periodically compare installed equipment with equipment established as an authorized or recognized standard and to correlate or adjust as necessary the tested equipment to meet the standard. Enter "C" for "calibrate" in subcolumn G2 when applicable. **ADJUST** (or *aline*) identifies the requirement to mechanically or electronically bring into a

specified tolerance any subsystems, module, or component for the purpose of making the functional assembly (or assemblies) operate as a unit; e.g., setting of limit switches, pressure valves, adjusting clutch faces. Enter "A" for "adjust" in subcolumn G2 when applicable.

Subcolumn G3—REMOVE identifies the requirement to disconnect, unmount, and physically remove any equipment configuration from any other equipment configuration; e.g., remove a drawer assembly from an OGE console for a scheduled inspection. Enter "R" for "remove" in subcolumn G3 when applicable. **INSTALL** identifies the requirement to connect, mount, and physically return the item removed to its original configuration. Enter "I" for "install" in the column G3 when applicable.

Subcolumn G4—REPLACE indicates the requirement to replace the items under analysis with a serviceable item. Enter "R" for "replace" in subcolumn G4.

Subcolumn G5—REPAIR identifies the requirement to replace unserviceable components and/or parts or structural repair exclusive of complete disassembly or teardown of the equipment. Enter "R" for "repair" in the subcolumn G5 when applicable. (*NOTE: Repair of subsystems and major assemblies usually consists of the removal, replacement, and repair of lower indenture components.*) **OVERHAUL** identifies the requirement for complete disassembly, detailed inspection, rework, replacement of unserviceable parts, assembly and test of equipment. Entry of an "O" for "overhaul" in subcolumn G5 indicates that the contractor recommends that further repair or maintenance of the item should be accomplished at a depot.

Subcolumn G6—PROTECT identifies the requirement to provide environmental protection for any item of equipment in any configuration status; e.g., temperature control, humidity control, air condition control, pressurize, contamination detection, place in containers, etc. Enter "P" for "protect" in subcolumn G6 when applicable. **SERVICE** identifies the requirement for replenishing fuel, gases, liquids, chemical solids, dessicants, and lubricants. Enter "S" for "service" in subcolumn G6, when applicable.

Subcolumn G7—VISUAL CHECK identifies the requirement to visually inspect any equip-

ment configuration for all external defects that may be identified visually, such as fluid or gas leaks, dents, corrosion, and other physical conditions. Enter "V" for "visual check" in subcolumn G7 when applicable. INSPECT identifies the requirement to perform necessary actions after maintenance to insure quality of repair. This function generally applies to mechanical items and would include such functions as inspecting installation of safety wires and inspecting welds. Enter "I" for "inspect" in subcolumn G7, when applicable.

Subcolumn G8—CLEAN identifies the requirement to remove residual accumulations of dust, dirt, oils, fuels, gases, liquids, and lubricants. Included in this definition is the cleaning required in preparation for inspection. Preparation for application of preservation substances is accomplished by washing with soap, water, detergents, solvents, vapors, sonic, or other cleaning methods. Enter "C" for "clean" in subcolumn G8 when applicable. PURGE identifies the requirement to expel from a subsystem, or assembly thereof, unwanted contaminants, fumes, vapors, gases, and liquids by means which do not require the disassembly of the subsystem or assembly thereof, but rather accomplish the cleaning function by expelling or extracting the unwanted contaminants (hydraulic fluid, fluorolube, etc.) from the environment or environment vehicle. For example, bleeding a hydraulic system to remove air, expelling fuel vapors from lines and tanks by running dry nitrogen through the system, or removing fluid from subsystem, or purifying and returning the same fluid to the same subsystem. Enter "P" for "purge" in subcolumn G8 when applicable. DECONTAMINATE identifies the requirement to remove toxic contaminants. Enter a "D" for "decontaminate" in subcolumn G8 when applicable. Enter also the appropriate hazard designation as specified in paragraph 3.2.6.2.1 of MIL-S-38130.

Subcolumn G9—COMPOSITE TEST (or composite checkout) identifies the requirement to establish that the operating parameters have been met after integrating the item with multiple subsystems. Normally, composite test is performed on a complete aerospace vehicle or

complete ground subsystem; e.g., combined subsystem test, ground subsystem self test.

Subcolumn G10—SYSTEM ALINE identifies the requirement (after maintenance and composite testing) for restoring the system to total mission capability; e.g., securing a facility and removal of maintenance personnel and equipment. These requirements should normally be identified in detail on the RAS and associated functional diagrams. Enter an "S" for system "aline" in subcolumn G10 when applicable.

Subcolumn G11—STORE and HANDLE functions are self-explanatory and will usually be generated on a "whenever" basis; e.g., an item must be handled "whenever" it is removed. Enter "S" or "H" for "store" or "handle," in subcolumn G11 when applicable.

Subcolumn G12—MONITOR and OPERATE. This entry indicates whether the item is either continuously monitored or continuously operated. Enter "M" for "monitored," "O" for "operated," and "B" for "both" in subcolumn G12 when applicable.

Subcolumn G13—OTHER. This entry indicates that a function other than those listed is required to maintain the item under analysis; e.g., stop, disconnect, move, hold, etc.; enter "x" in subcolumn G13 when applicable and provide explanation in the RAS.

Subcolumn G14—INTERFACE. INTERFACE identifies the requirement that two or more subsystems or components to be used in conjunction to perform maintenance on a complete system configuration. Enter an "x" for "interface" in subcolumn G14 when applicable and provide an explanation in the RAS.

Column H—This column is subdivided into three subcolumns within which is recorded the contractor's frequency recommendation relevant to the requirements for preventive maintenance. Also to be recorded is the frequency of corrective maintenance for each applicable function identified in column G. If a specific function occurs at two different frequencies, a separate line will be used for each frequency at which the function is accomplished. Entries made in this column will be recorded as follows:

Subcolumn H1—This subcolumn shall be used to indicate the calendar and/or operating

time cycles that may be accumulated on the item under analysis prior to requiring accomplishment of the maintenance function indicated on the same line to keep the item in the ready status or to return it to ready status. Periodic visual inspections, service functional tests, calibration, adjustment, and replacement of assemblies or parts are examples of requirements to which this subcolumn may apply. Frequencies of functions identifying operating or calendar time will be entered as a number followed by one of these letter codes: D=Days, M=Months, S=Seconds, H=Hours, C=Cycles; e.g., "15D" would indicate the functions were required every 15 days. The reporting of the functions and their schedule will be in accordance with the following instructions: Reasons for the frequency selection shall be narrated on the RAS in the "Design Requirements" column to substantiate performance of the functions. If the maintenance function is schedules but not on the basis of time (operating or calendar), the requirement shall be entered under the preventive column using the following codes when applicable:

(1) PI—This code identifies a maintenance function required PRIOR TO INSTALLATION in the equipment configuration for which it is intended.

(2) R—This code identifies a maintenance function required upon RECEIPT from the factory/depot.

(3) PM—This code identifies a maintenance function required PRIOR TO MISSION.

(4) POM—This code identifies a maintenance function required after every POST MISSION or post start period. Post start would include an aborted mission condition.

(5) PU—This code identifies a maintenance function required PRIOR TO USE of the item.

Subcolumn H2—This entry identifies the corrective maintenance interval for corrective maintenance functions. The failure rate shall be identified in the terms of number of failures per month per unit such as wing or number of cycles of operation to failure. The code designating the time unit and the quantity shall be entered in the same manner as subcolumn H1 entries.

Subcolumn H3—When accomplishment of a particular function requires that additional functions be performed, an "x" will be entered in subcolumn H3. For example, if whenever a given module is replaced the system required "checkout," then this checkout will be indicated as a "whenever" function to be accomplished at the interval identified in columns H1 and H2. The "x" in the "whenever" column refers to the preceding function.

Column J—This column identifies the period of time, expressed in calendar months, when an item may remain in serviceable stock for issue. At the end of this time, the item must be withdrawn from serviceable status for maintenance actions to reestablish its operational reliability for an additional period; e.g., replacement of cured dated parts, functional test required, renew packaging and/or preservative. Enter calendar months in this subcolumn or "IND" if the item has an indefinite shelf life.

Column K—This column is used to correlate levels of maintenance to be accomplished with maintenance locations within the systems complex. The column may be divided into subcolumns for identifying the gross maintenance locales of the system. For example, SRA, squadron maintenance shop, support base, and flight-line maintenance. Each horizontal line entry identified by a maintenance function in column G shall be coded with the appropriate subcolumns of K as to the specific area recommended for performance.

Column L—Whenever equipment is required to accomplish a function or to aid in accomplishing a function as determined from the RAS, an identifying number of the MGE recommended will be entered in this column. This number will either be CEI number, Detail Specification number, or index number. When base-procured (BP) or local-purchase (LP) items are involved for which the design sheet or applicable specification is not applicable, the contractor shall identify equipment recommendations of this type by index number and whether BP or LP. AFR 67-3 should be used as guidance for AF criteria in deciding on LP/BP items.

Column M—Every item of equipment listed on this sheet (system-installed, primary spare,

secondary spare) is a spare configuration required by maintenance. Column M is subdivided into five subcolumns. Information required by provisioning for each spare configuration will be entered in the subcolumns as follows:

Subcolumn M1—Source Code. The method of determining codes for this column after equipment has been analyzed is contained in part four, AFSCM 65-2, AFLCM 65-3. Entries made in this subcolumn will reflect in code from the analysis data contained in the previous column entries which pertain to the equipment configuration as a spare to be applied by maintenance at a specified maintenance level.

Subcolumn M2—Maintenance Repair Level Code. Enter maintenance repair level code.

Subcolumn M3—IR. Interchangeable and replaceable status shall be entered in this subcolumn in accordance with MIL-I-8500.

Subcolumn M4—Quantity/Assembly. Enter a figure indicating the total number of times the

item is used in the next higher assembly. "Assembly" is defined as "a number of parts or subassemblies or any combination thereof joined together to perform a specific function."

Subcolumn M5—Quantity/Article. Enter a figure indicating the total number of times the item is used in the next higher assembly. "Article" is defined as "a component or components and necessary assemblies, subassemblies, and parts connected or associated together to perform an operational function (end item)."

8.1 Identifying Information. Appropriate identifying information including the revision letter, date, approval, document number, and page number shall be entered at the bottom of the sheet.

8.2 Example of End Item Maintenance Sheet. For an example of an end item maintenance sheet, reference attachment 2.

8.3 AFSCM/AFLCM 310-1 Data Item Number. Reference S-59-6.1.

Figure 14. End Item Maintenance Sheet (Manual).

9.0 MAINTENANCE LOADING ANALYSIS. To determine the impact of design on the quantity of MGE, personnel, and spares required to maintain the system, it is necessary to correlate the MGE, personnel, and spares required with the maintenance functions to be performed. Paragraphs 9.1, 9.2, and 9.3 present an example of a methodical way of correlating maintenance

loading requirements. Use of the formats provided in figures 15, 16, and 17 is not mandatory. The contractor may develop other formats tailored to his system. The approach chosen, however, should combine the selected data element requirements specified in the example into an effective maintenance loading analysis procedure.

9.1 Example of Maintenance Loading Sheet. Requirements for completing figure 15 are as follows:

Block A—Location. Enter the area in which maintenance is to be accomplished.

Block B—Types of Maintenance Preventive or Corrective. Underscore the type of maintenance to be performed as either preventive or corrective.

Block C—Time Line Sheet. Information in columns D and E is derived directly from the time line sheet. No entry is required in block C.

Column D—Source of Function. Enter functional diagram number in the cases where the source of the function is the functional diagram. Enter the end item maintenance sheet line item and CEI number in the cases where the function has been derived from that sheet.

Column E—Functions and Corresponding Tasks. Enter the functions and corresponding tasks (if applicable) contained on the RAS. In the cases where tasks are applicable, enter the AFSC.

Column F—Indenture. Enter the equipment breakdown level appearing on the maintenance sheet.

Column G—Frequency of Function. The maintenance frequency or average number of times per month that a given function and corresponding tasks must be performed for a given system force structure is entered in this column. For corrective maintenance, the maintenance frequency and failure rate of the equipment being maintained is identical. The failure rate data are to be obtained from the design sheet and the maintenance sheet. For example, if the force size involves a 50-unit wing and the function to be performed is based on an MTBF of 7200 hours, the frequency of the function would be determined as follows:

$$\begin{aligned} \text{Frequency rate} &= \frac{\text{Force Size} \times \text{Hours}}{(24 \text{ day} \times 30 \text{ day month}) \text{ MTBF}} \\ &= \frac{50 \times 720}{7200} = 5/\text{Wing/month} \end{aligned}$$

Preventive maintenance frequencies are obtained directly from the maintenance sheet.

Column H—Time Line (Hours). The total maintenance loop time derived from the time line sheet for a particular function is entered in this column.

Column J—Number of Personnel (AFSC). The number and types of personnel by AFSC required to perform the function are to be entered in this column. Entries are derived from the requirements information on the RASs.

Column K—Man-Hours Maintenance. The total man-hours expended per AFSC per maintenance function is entered in this column. Where one or more men of the same AFSC are occupied for the total elapsed time of the function, the entry in this column is the product of (number of people) (frequency of function) (time line); i.e., columns J, G, and H. Where several AFSCs are required to perform the function, the entries in this column are calculated from the time lines. The man-hours by AFSC are added together and multiplied by the frequency (column G) to derive the man-hours maintenance entry.

Column L—Man-Months. The time in this column is obtained by dividing each entry in column K by 140 (average productive hours per man per month on a single-shift basis allowing percentage for nonwork time).

Column M—Down Time. Entries in this column shall reflect the total time per month that the operational system is out of commission for maintenance. The time in this column is the product of the frequency of functions and time line information contained in columns G and H. It shall be emphasized that the time in this column represents the total length of time it takes to restore the system to an alert or ready status following the detection of a malfunction or the accomplishment of preventive maintenance. As such, it would include, where necessary, travel time and the actual organizational-level maintenance required to return the system to an alert or ready status.

Column N—Spares Quantity/Month. Entries in this column show the number of spares required per month. The spares quantity is to be based on a consideration of the failure rate of the item, the optimum maintenance response to fault indications, and, as necessary, the re-

pair cycle from removal of the malfunctioning item to its restoration as a serviceable spare.

Column O—MGE Utilization. Entries in this column shall indicate the number of times per month each piece of MGE is to be used for a particular function (column G), the time required to perform the function (column H), and the utilization that is to be made of MGE. The MGE utilization is a product of the number of times per month each piece of MGE is to be used for a particular function (column G) and the time required to perform the function (column H) divided by equipment availability (assume equipment available for use 8 hours per day for 30 days a month).

Column P—MGE Identification. This column shall contain the identification of the MGE to be used for each function by CEI number and appropriate nomenclature.

9.1.1 Identifying Information. Appropriate identifying information including the revision letter, date, approval, document number, and page number shall be entered at the bottom of the sheet as indicated.

9.1.2 Example of Maintenance Loading Sheet. For an example of a maintenance loading sheet, reference attachment 2.

9.1.3 AFSCM AFLCM310-1 Data Item Number. Reference S-00-15.0.

9.2 MGE Utilization Sheet. Requirements for completing the MGE utilization sheet are as follows.

Column A—MGE CEI Number. Enter the CEI number of the MGE under consideration.

Column B—Nomenclature. Enter MGE nomenclature in this column.

Column C—Quantity in Use by Maintenance Location. Subcolumn headings shall be added to the chart which identifies the maintenance locations of the systems. Under each of these locations and opposite the MGE identified in columns A and B, the utilization frequencies appearing in column O of the maintenance loading sheet shall be tabulated.

Column D—Quantity of MGE Recommended. This entry shall summarize (across columns 1 through 5) the quantity recommended to support a given system force structure. In the computation of quantity requirements, consideration shall be given to the utilization of items at multiple locations: e.g., if a unit is used only 25 percent of the time at one location and 25 percent at another location, it might be possible to employ a simple unit for both locations. Information appearing in column D represents

MAINTENANCE LOADING SHEET		A LOCATION _____								B TYPE OF MAINTENANCE PREVENTIVE OR CORRECTIVE				
C THE LINE SHEET		D MGE CEI NUMBER	E POS. OF FUNCTION	F TIME LINE REQD.	G NO. OF PI P A (A/CD)	H MGE REQD EASST	I MGE REQD EASST	J MGE REQD EASST	K MGE REQD EASST	L MGE REQD EASST	M MGE REQD EASST	N MGE REQD EASST	O MGE REQD EASST	P MGE REQD EASST
1 SOURCE OF FUNCTION	2 FUNCTION & CORRESPONDING TABLE													

REVISION _____ DATE _____ APPROVAL _____ DOCUMENT NO. _____ PAGE NO. _____ OF _____

Figure 15. Maintenance Loading Sheet (Example).

the recommended provisioning quantity requirement.

9.2.1 Identifying Information. Appropriate identifying information including the revision letter, date, approval, document and page

number shall be entered at the bottom of the sheet.

9.2.2 Example of MGE Utilization Sheet. For an example of a MGE utilization sheet, reference attachment 2.

MGE UTILIZATION SHEET		C QUANTITY BY MAINTENANCE LOCATION								D CAPACITY REQUIREMENT
		1	2	3	4	5	6	7	8	
A AFSC NUMBER	B DESCRIPTION									

REVISION _____ DATE _____ APPROVAL _____ DOCUMENT NO. _____ PAGE NO. _____ OF _____

Figure 16. MGE Utilization Sheet (Example).

9.2.3 AFSCM/AFLCM 310-1 Data Item Number. Reference S-61-18.0.

9.3 Example of Personnel Utilization Sheet. Requirements for completing figure 17 are as follows:

Column A—AFSC. Enter the AFSCs tabulated on the maintenance loading sheets in increasing serial code numbers.

Column B—Title and Tasks. Enter the title and corresponding tasks of the AFSC derived from the loading sheets, RAS, and maintenance sheets.

Column C—Man-Months by Maintenance Location. The subcolumn headings shall be identical to those established for the MGE utilization sheet. Under each of the subcolumns and opposite each AFSC identified, enter the man-month figure derived from column L of the maintenance loading sheet.

Column D—Total Man-Months. This column shall summarize (across columns 1 through 8) the quantity of personnel recommended. As in the case of MGE quantities, consideration shall be given to the employment of personnel

PERSONNEL UTILIZATION SHEET		C QUANTITIES BY MAINTENANCE LOCATION								D TOTAL MAN-MONTHS
		1	2	3	4	5	6	7	8	
A AFSC	B TITLE AND TASKS									

REVISION _____ DATE _____ APPROVAL _____ DOCUMENT NO. _____ PAGE NO. _____ OF _____

Figure 17. Personnel Utilization Sheet (Example).

10 March 1966

AFSCM 375-5

at multiple locations as a function of personnel availability.

9.3.1 Identifying Information. Appropriate identifying information including the revision letter, date, approval, document and page number shall be entered at the bottom of the sheet.

9.3.2 Example of Personnel Utilization Sheet. For an example of a personnel utilization sheet, reference attachment 2.

9.3.3 AFSCM/AFLCM 310-1 Data Item Number. Reference S-62-18.0.

10.0 CALIBRATION REQUIREMENTS SUMMARY (CRS) (see figure 18):

10.1 Requirements. Calibration and certification requirements shall be considered during all phases of system design and production. The calibration workload and the out-of-commission time are significant factors that must be reviewed periodically during the design process to assure that the total system can be efficiently maintained. The maintainability aspects of the components and the various subsystems shall be examined to form an estimate of time and manpower required for calibration. In assuring a minimum calibration workload, the contractor will normally give the consideration to the use of test points or taps, end to end calibrations, accessibility, and degree of actual calibration required based on the operational system requirements. An objective is to provide for calibration to proper standards based on manufacturing specifications. Calibration requirements summaries shall be prepared as condensed, factual records of the contractor's review and evaluation of the parameters which must be measured, the necessary accuracies, and the time involved in calibration.

a. Data shall be prepared on a summary sheet in accordance with figure 18 and shall be submitted as full-size black-and-white copy, on a good quality of paper equivalent to 20-pound sulphite bond. An original and three copies are required.

b. Unless otherwise specified, revisions to CRSs will be accomplished when corrections or revisions to previously approved CEI are approved or design changes in end items or AGE create changes in parametric values or means of measurement.

10.2 Content:

a. The CRS is divided into four basic categories of equipment. The first category of equipment represents operational equipment such as major subsystem, components of the end item, and operating ground equipment, further reduced to an analysis of the components having measurement parameters requiring periodic calibration or verification. In general, each succeeding category of equipment represents equipment that is required to calibrate or verify the preceding category of equipment. Each item of equipment in each succeeding category is also reduced to an analysis of the measurement parameters requiring calibration or verification. The last category of equipment represents the standards for calibration to be used by the Air Force base precision measurement equipment laboratory (PMEL). It is not required that the contractor complete this last category, except where an item is required and is not defined in T.O. 33-1-14. (The space shall be provided on the CRS for use by the Air Force activities.)

b. The information required on the CRS is extracted and transposed from the engineering data furnished in the chain of approved CEIs, and direct reference shall be made to the CEI item name and number.

c. The summary shall indicate the ranges and accuracies of the parameters to be measured by each specific item comprising the chain of equipment from the operational requirement to the base laboratory standards. This document shall summarize test equipment requirements in both kind and quantity and thereby assure that all parameters to be measured are considered and satisfied, and the potential workload of a base PMEL can be appraised.

d. Summaries for more than one type of equipment or parameter may be contained on one page. Similar types of parameters (Cat I) should be grouped on successive pages; however, it is not desired that data be held until a large number of similar summaries can be accumulated.

e. Data provided by subcontractors or associate contractors shall be segregated in separate sections of the CRS.

10.3 Composition of the Calibration Requirements Summary. The four categories and applicable columns are defined as follows:

a. *Category I*—Operational system, subsystem, or operating ground equipment whose parameters are to be measured, verified, or adjusted to specific tolerances.

(1) *Content No.*—An identification or reference number used to display the sequence of breakdown or physical location of the item listed in the next succeeding column. Only items of hardware and measurement requirements will be identified with a content number.

(2) *Description of Item*—The identification of the system, subsystem, equipment, assembly, module or component by nomenclature, manufacturer and part number; and its functions which must be measured, tested, verified, checked, adjusted, or calibrated in order to determine its operational characteristics. If item is identified as an approved CEI item, the CEI number shall also be referenced.

(3) *Specification Range and Accuracy*—The manufacturer's range and tolerance. Example: 25-0-25 volts dc, 2 percent full scale.

(4) *Operational Range or Specific Value*—The range or values required by the operational equipment that must be calibrated to meet the end item or AGE operational specifications. Example: 14-0-14 volts dc, 1.88 volts dc.

(5) *Operational Tolerance*—The accuracy requirements within which the equipment must perform to meet operational specifications. Example: 5 percent full scale.

(6) *Calibration Interval*—The calibration interval or time lapse recommended by the contractors between calibration or verification.

(7) *Number per Squadron*—The quantity recommended for each squadron.

(8) *Time Required to Calibrate*—The elapsed time required to complete only the actual verification or calibration of the particular item. This should not include transportation or removal and reinstallation time.

(9) *System Down Time*—The total elapsed time the system will be out-of-commission to complete the verification or calibration of this particular item. The time listed shall be that required if only this particular item was being

calibrated. If there are identical items that will usually be calibrated during this time, the time listed shall be the consolidated time out of commission for calibrating the group. However, for nonsimilar items, the time listed shall be the time out of commission to calibrate that item, although other items might be calibrated at the same time.

b. *Category II*—Peculiar measurement equipment required to check out, maintain and calibrate category I equipment. Examples: test sets, fault isolation equipment, etc. Applicable columns are:

(1) *Description of Item*—The identification of the measurement equipment by nomenclature, manufacturer and/or part number, and its functional capabilities to support the preceding categories.

(2) *Specification Range or Specific Value*—The limits of performance as defined by the manufacturer to meet the requirements in the preceding categories.

(3) *Specification Tolerance*—The amount of deviation from the nominal as defined by the manufacturer.

(4) *Calibration Interval*—(Same as in para. 10.3a(6).)

(5) *Number Per Squadron*—(Same as in para. 10.3a(7).)

(6) *Time Required to Calibrate*—(Same as in para 10.3a(8).)

c. *Category III*—Precision measurement equipment: (commercial or Air Force standard items) used for maintenance, trouble shooting, testing, verification, or calibration of category I and II items. Applicable columns and descriptions are the same as described in paragraph 10.3b.

d. *Category IV*—(see para. 10.2a)—Calibration equipment used to calibrate items in category II and III. (These items are normally assigned to the base precision measurement equipment laboratory). Applicable columns are:

(1) *Description of Item*—(Same as para. 10.3b(1) or 88k technical order number.

(2) *Specification Range or Specific Value*—The limits of use as defined by the manufacturer or 88K series technical order calibration instructions.

(3) *Specification Tolerance*—The amount of deviation from the nominal as defined by the manufacturer or 33K series technical order calibration instructions.

(4) *Calibration Interval*—(Same as in para. 103a(6).)

10.4 General Format Arrangement and Instructions. The format is arranged to permit reading from left to right for each item of equipment, with increasing accuracies in each category. There may be precision measurement equipment listed in category III used for "maintenance and trouble shooting equipment" below the calibration or verification items prior to next list of category I item.

a. Each assembly or AGE item will be listed under "Description of Item" column by CEI number, specification number, and nomenclature. Assemblies shall be identified by numerals in the "Content Number" column. Each assembly shall be further broken down into subassemblies for panels and identified by letters in the "Content Number" column. A further breakdown of the assembly shall be made until each segment is identified presenting one or more parameters to be measured (see fig. 18).

b. Where automatic checkout equipment is used, it may be difficult to identify all measurement parameters accomplished by the automatic equipment. Where it is not practical to identify such parameters, it shall be sufficient to identify the verification references or standards within the checkout equipment. These reference standards might be such items as reference diodes, standard cells, precision resis-

tors, etc. If this is the case, then these standards with their ranges and tolerances shall be referred to as category I items.

c. If the overall parameters being measured by the automatic checkout equipment can be readily identified, then they shall be so listed under category I and the checkout equipment shall be shown under category II. In this case, the measured ranges and their tolerances shall be entered in the columns for operational range or specific value, and operational tolerance, of category I. An example might be: DC voltages from 10 volts to 100 volts plus or minus 0.1 volts, voltages from 10 to 500 volts plus or minus 0.5 volts, 320 volts plus or minus 0.5 volts, AC, 400 c.p.s. voltages, 3 to 150 volt, etc. This method will permit easy verification of the suitability of the reference standards. Standard and commercial test equipment items fall into three classes as follows:

- (1) Precision measurement equipment (PME) used for calibration and placed in category III.
- (2) Maintenance and trouble shooting equipment and listed in category III.
- (3) Components of peculiar items and listed in category I or II.

Except when AGE items are used for maintenance and trouble shooting, the system parameters to be checked with the item shall appear in the preceding operational range and tolerance columns.

d. There will be cases where an operational system check in category I may require calibration or verification by an item listed in category

The table in Figure 18 is a summary of calibration requirements. It is organized into four main columns, each representing a different category of equipment or parameter. Each column contains a grid of rows, with some cells containing specific technical data and others containing diagonal lines, indicating that the data is not applicable or is to be determined elsewhere. The columns are labeled as follows from left to right: 'OPERATIONAL RANGE - CATEGORY I', 'OPERATIONAL RANGE - CATEGORY II', 'OPERATIONAL RANGE - CATEGORY III', and 'CALIBRATION INTERVAL - CATEGORY IV'. The rows represent different parameters to be measured or calibrated, such as 'DC VOLTAGE', 'AC VOLTAGE', 'RESISTANCE', etc. The table also includes a 'CONTENT NUMBER' column and a 'DESCRIPTION OF ITEM' column.

Figure 18. Calibration Requirements Summary.

III or IV due to the accuracy requirement. In these cases, the unused category columns shall be annotated "N/A" to denote nonapplicability. The use of a category IV item to calibrate a category I item at the operating position shall be avoided, whenever possible.

e. In the case of pressure gages, there will normally be transfer gages to be connected in the line for comparison and verification of the operating gage. The transfer gage in this case will be a category II item, supported by a test stand as a category III item, and the dead-weight tester used by the PMEL to calibrate the test stand will be a category IV item. Transfer gages may be designated as category III items and if no other test gage is used, category II will be marked "N/A." If the basic gage is not a part of the system during countdown but is used as an operating gage in

a particular test stand, the test stand, would be listed as a category II item.

f. It is not intended to provide calibration capability at base precision measurement equipment laboratory level to calibrate all working standards. In those cases where it is not economical to provide this capability, the items will be exchanged. If the working standards are the property of the squadron (category III), the base precision measurement equipment laboratory (category IV) will be responsible to have a calibrated exchange item on hand at the correct time for exchange. Example of such items are dead weight testers, standard cells, etc.

10.5 Example of Calibration Requirements Summary. For an example of a calibration requirements summary, reference attachment 2.
10.6 AFSCM/AFLCM 310-1 Data Item Number. Reference S-83-23.0.

EXAMPLES OF SYSTEM ENGINEERING DOCUMENTATION

1.0 FUNDAMENTAL CYCLE OF SYSTEM ENGINEERING MANAGEMENT PROCESS. Figures 19 through 26 provide an example of the fundamental cycle of the system engineering management process and documentation described in chapter 6.

1.1 Step 1. Step 1 of the process begins with the preparation of functional diagrams. Step 1 of this example starts with the third-level functional diagram: figure 21. Figures 19 and 20 show the preceding first- and second-level functional diagrams to provide background for the example.

1.2 Step 2. Figure 22 represents a trade study matrix in support of step 2. Step 2 consists of an analysis of the functions on the third-level functional diagram through the use of the requirements allocation sheet (RAS) shown in figure 23. The trade study matrix provides an input to the RAS for a requirement for storing pneumatic energy to release the activators. It should be noted that the trade study between

electrical, hydraulic, and pneumatic approach may not, in a real case, require a Trade Study Report, but is included here to present a simple illustration of a trade study.

1.3 Step 3. Step 3 of the process is to accomplish and document the trade study as illustrated by a matrix in figure 24. Trade studies may support either step 1, 2, or 4 and may occur prior to, during, or after these steps. For example, figure 22 supports step 2, whereas figure 24 supports step 4. Figure 25 is a schematic diagram in support of step 3.

1.4 Step 4. Step 4 involves the integration of design requirements on the RAS shown in figure 23 into a CEI by means of the design sheet. One resulting CEI is shown in figure 26. For the purpose of this example, the stage latic activator unit was selected as a CEI due to its diverse requirements. The qualitative and quantitative requirements shown in figure 26 are representative of the depth anticipated at the end of phase IB.

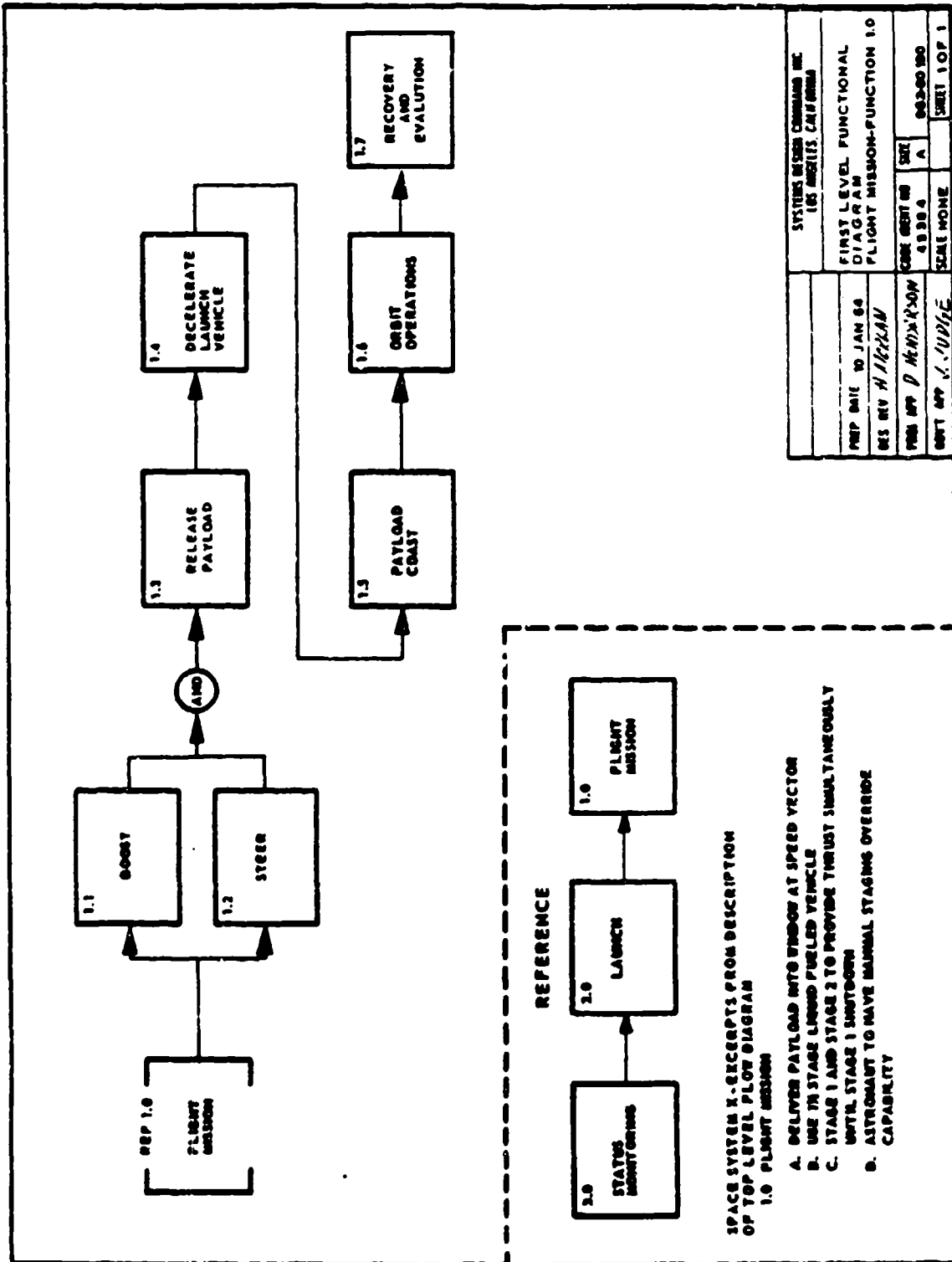
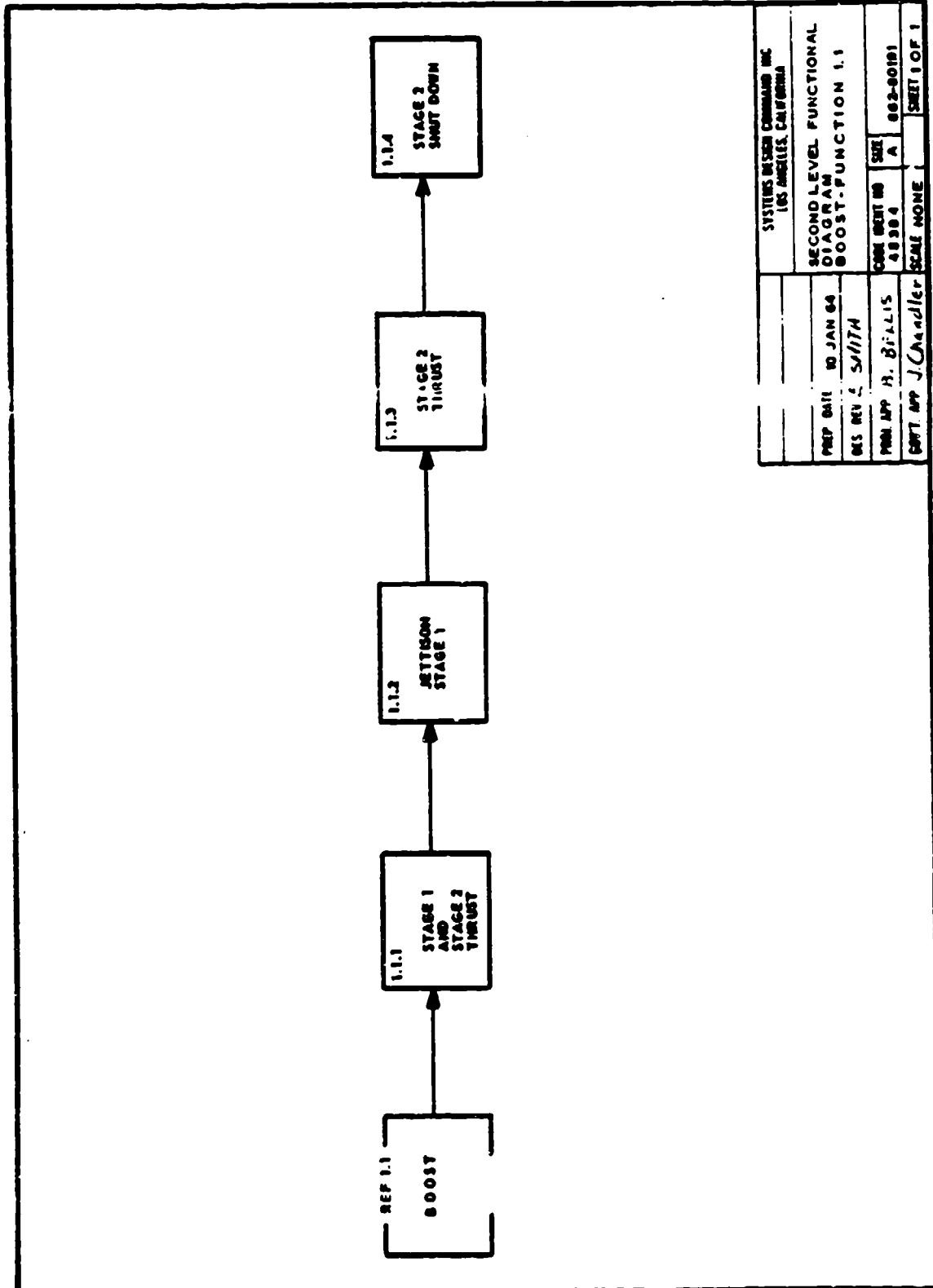

Figure 19. First-Level Functional Diagram Preceding Example of Step 1.



SYSTEMS DESIGN COMMAND INC LOS ANGELES, CALIFORNIA	
PREP DATE	10 JAN 64
DES REV	4 S/17H
PREP APP	H. B. FALLIS
DATE	10 JAN 64
SCALE	NONE
SHEET 1 OF 1	

Figure 20. Second-Level Functional Diagram. Preceding Example of Step 1.

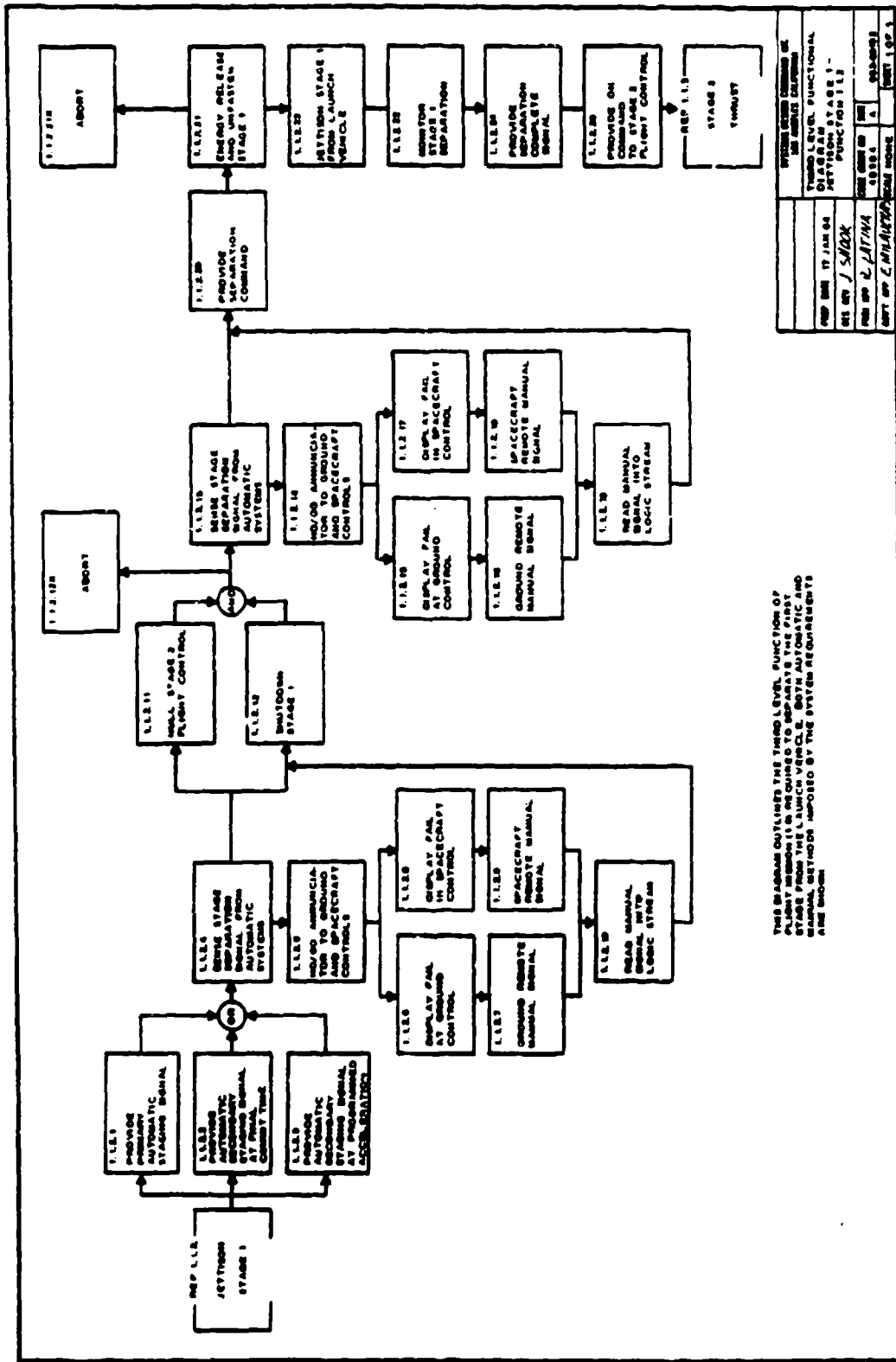

Figure 2: Step 1 of System Engineering Management Process.

NOMENCLATURE		COMPARISON MATRIX OF DESIGN APPROACHES			SELECTION
Track-Off Jetstream Stage 1		1	2	3	
<p>POWER</p> <p>Means shall be provided to cause either automatic or manual (override by astronaut) separation of the Stage 1 engine motor (helium) section from the launch vehicle within 800 milliseconds of a staging command. (Reference function 1.1.2 and SAS Document 2-00002 16 Feb 1966.)</p> <p>Locate helium pressure flask in Stage 1 assembly.</p> <p>Jetstreaming Stage 1 shall not cause damage to the launch vehicle. (Reference function 1.1.2 and SAS Document 2-00002 16 Feb 1966.)</p> <p>Interface</p> <p>Use available 28 VDC airborne electrical system.</p> <p>Procurability</p> <p>Staging status data shall be monitored and relayed to ground control and spacecraft. (Reference function 1.1.2 and SAS Document 2-00002 16 Feb 1966.)</p> <p>Use commercially available parts where possible.</p>	<p>ELECTRICAL APPROACH</p> <p>A signal from guidance through the autopilot programmer energizes a solenoid which physically disconnects the fastening device.</p> <p>Energy Source: Battery</p> <p>DISCUSSION</p> <p>PRO</p> <p>1. Simpler, straight-forward logic. Self contained power source.</p> <p>2. No problem to design effective manual override display and control.</p> <p>CON</p> <p>1. The solenoid requires too much power, drain on battery.</p> <p>2. Surges cause voltage spikes and interference with other electronic systems.</p> <p>3. A relay is needed to translate the guidance signal into solenoid power control. Relays and solenoids have a poor reliability history.</p>	<p>HYDRAULIC APPROACH</p> <p>A signal from guidance through the autopilot programmer controls a hydraulic valve. Energy to actuate the unlatching device is drawn from the anti-cipated airborne hydraulic power supply.</p> <p>DISCUSSION</p> <p>PRO</p> <p>1. The electrical energy required to operate a hydraulic valve is less than under Solution 1.</p> <p>2. Hydraulic power will be available in both Stage 1 & Stage 2.</p> <p>3. No problem to design effective manual override display and control.</p> <p>CON</p> <p>1. This method would involve tapping the stability control system, causing frequency response problems.</p> <p>2. Possible hydraulic leakage could cause a contamination problem.</p>	<p>HYDRAULIC APPROACH</p> <p>A signal from guidance through the autopilot programmer controls a pneumatic valve (for trade-off selection) which releases pneumatic pressure into a cylinder/actuator. A pushrod actuates the unlatching mechanism. Energy will be supplied by the airborne pneumatic system.</p> <p>DISCUSSION</p> <p>1. The electrical energy required to operate the pneumatic valve is less than under Solution 1.</p> <p>2. Leaks would not cause catastrophic failure.</p> <p>3. Tapping the existing airborne pneumatic system does not cause interference with other consumers of pneumatic energy.</p> <p>4. No problem to design effective manual override display and control.</p> <p>CON</p> <p>1. In-line lines are difficult to seal.</p>	<p>Performance 3. 2. 1</p> <p>Maintainability 1. 3. 2</p> <p>Reliability 3. 2. 1</p> <p>Safety 3. 1. 2</p> <p>Procurability 1. 3. 2</p> <p>SELECTION</p> <p>Solution 3</p> <p>NOTE: See Section 4 of trade study report for reasons of selection.</p>	
<p>FUNCTIONAL & TECHNICAL DESIGN REQUIREMENTS</p>					
<p>For example purposes only representative requirements and partial discussion are listed.</p>					

Figure 22. Trade Study No. 7 Support of Step 2.

REQUIREMENTS ALLOCATION SHEET	Function, Diagram Title and No. or Reference and No. of CEI		Equipment Identification		PERSONNEL AND TRAINING EQUIPMENT REQUIREMENTS				Procedural Data Requirements
	Function Name & Number	Design Requirements	Facility Requirements	Manpower	CEI or Detail Spot or Index or Master Control Number	Tests	Time Req	Performance Requirements	
1.1.2.1 Function Name & Number	Design Requirements	Facility Requirements	Manpower	CEI or Detail Spot or Index or Master Control Number	Tests	Time Req	Performance Requirements	Top & Top Equip Req	Procedural Data Requirements
1.1.2.1.1 Function Name & Number	Design Requirements	Facility Requirements	Manpower	CEI or Detail Spot or Index or Master Control Number	Tests	Time Req	Performance Requirements	Top & Top Equip Req	Procedural Data Requirements
1.1.2.1.2 Function Name & Number	Design Requirements	Facility Requirements	Manpower	CEI or Detail Spot or Index or Master Control Number	Tests	Time Req	Performance Requirements	Top & Top Equip Req	Procedural Data Requirements
1.1.2.1.3 Function Name & Number	Design Requirements	Facility Requirements	Manpower	CEI or Detail Spot or Index or Master Control Number	Tests	Time Req	Performance Requirements	Top & Top Equip Req	Procedural Data Requirements
1.1.2.1.4 Function Name & Number	Design Requirements	Facility Requirements	Manpower	CEI or Detail Spot or Index or Master Control Number	Tests	Time Req	Performance Requirements	Top & Top Equip Req	Procedural Data Requirements
1.1.2.1.5 Function Name & Number	Design Requirements	Facility Requirements	Manpower	CEI or Detail Spot or Index or Master Control Number	Tests	Time Req	Performance Requirements	Top & Top Equip Req	Procedural Data Requirements

Revision 1 Date 10 Mar 1966 Approval 4. M. ... Document Number ... Page Number 121

Figure 23. Step 2 of System Engineering Management Process.

REQUIREMENTS ALLOCATION SHEET	Federal Program Title and No. _____ or _____		Equipment Identification		PERSONNEL AND TRAINING EQUIPMENT REQUIREMENTS				Procedural Data Requirements
	Nameplate and No. of CEI _____		Nameplate _____	CR or Detail Spot or Index or Master Control Number _____	Tasks _____	Time Req _____	Performance Requirement _____	Tap & Tap Equip Req _____	
	Design Requirements	Facility Requirements							
1.1.1.1.1.1.1	11 1000 1	10 10000 1
1.1.1.1.1.1.2	11 1000 2	10 10000 2
1.1.1.1.1.1.3	11 1000 3	10 10000 3
1.1.1.1.1.1.4	11 1000 4	10 10000 4
1.1.1.1.1.1.5	11 1000 5	10 10000 5
1.1.1.1.1.1.6	11 1000 6	10 10000 6
1.1.1.1.1.1.7	11 1000 7	10 10000 7
1.1.1.1.1.1.8	11 1000 8	10 10000 8
1.1.1.1.1.1.9	11 1000 9	10 10000 9
1.1.1.1.1.1.10	11 1000 10	10 10000 10

Revision _____ Date _____ Approval _____ Document Number 2.1.1.1.1.1.1 Page Number 1.1.1.1.1.1.1

Figure 23 (Continued). Step 2 of System Engineering Management Process.

REQUIREMENTS ALLOCATION SHEET	Functional Diagram Title and No.		Equipment Identifications		PERSONNEL AND TRAINING EQUIPMENT REQUIREMENTS			Procedural Data Requirements
	Module and No. of CI		Maneu- vres	CFI or Detail Spot or Index or Master Control Number	Tests	Time Req	Performance Requirements	
Function Name & Number	Design Requirements		Facility Requirements					
1.1.1.1 Circuit Breaker 1.1.1.1 1.1.1.1	1.1.1.1 Circuit Breaker 1.1.1.1 1.1.1.1		1.1.1.1 Circuit Breaker 1.1.1.1 1.1.1.1			1.1.1.1 Circuit Breaker 1.1.1.1 1.1.1.1		

Page Number 1-11

Document Number 2-200

Approval

Date 11/11/65

Revision 1

Figure 23 (Continued). Step 2 of System Engineering Management Process.

NOMENCLATURE		COMPARISON MATRIX OF DESIGN APPROACHES			SELECTION
Trade-off Release Energy to Unlatch Stage 1		1	2	3	
<p>FUNCTIONAL & TECHNICAL DESIGN REQUIREMENTS</p> <p>Operability Stored pneumatic energy shall be released by a valve to activate (the Stage 1 unlatching mechanism). Valve flow parameters must insure positive and rapid energy release to the unlatching mechanism. All connectors shall comply with military standards for threads and fittings (reference function 1.2.14 and BAS Document 2-00002 16 Feb 1964.)</p> <p>20 VDC 2.1.5 will be required to actuate the release valve (reference function 1.2.14 and BAS Document 2-00002 16 Feb 1964.)</p>		<p>SOLENOID VALVE</p> <p>A solenoid valve operated by a 20 VDC signal from guidance and control will relieve energy to the actuating mechanism.</p> <p><u>PRO</u></p> <p>1. Solenoid valve is an off the shelf component with standard line connectors.</p> <p><u>CON</u></p> <p>1. Solenoid. etc. heavy.</p> <p>2. Voltage spikes would be caused in the DC line.</p> <p>3. A heavy load would be imposed on diodes in the guidance and control autopilot programmer switch.</p>	<p>EXPLOSIVE VALVE</p> <p>An explosive valve operated by a 20 VDC signal from guidance and control will relieve energy to the actuating mechanism.</p> <p><u>PRO</u></p> <p>1. Explosive valve is an off the shelf component with standard line connectors.</p> <p>2. Low power is required to fire the explosive squib.</p> <p>3. No valve leakage prior to actuation.</p> <p>4. Instant response.</p> <p>5. Light weight.</p> <p>6. No voltage spikes would be caused in the DC line.</p> <p><u>CON</u></p> <p>1. The valve cannot be tamper tamably checked out, but has a good reliability record.</p>	<p>3</p>	<p>Performance 2.1</p> <p>Reliability 2.1</p> <p>Provenability 2.1</p> <p>SELECTION</p> <p>Solution 2</p> <p>NOTE: See section 6 of trade study report for reasons of selection.</p>
<p>For example purposes only representative requirements and partial discussion are listed.</p>					

Figure 24. Step 3 of System Engineering Management Process.

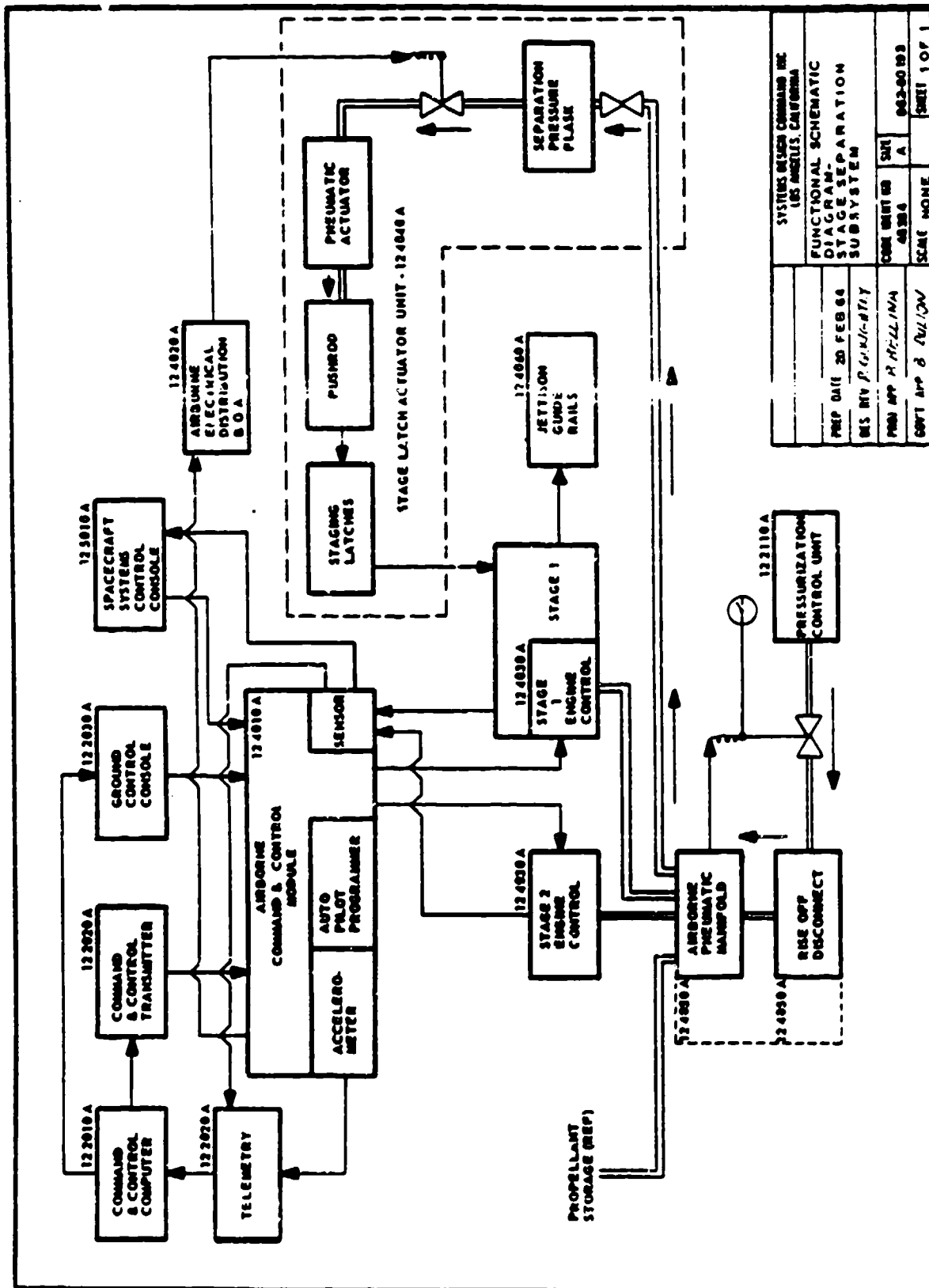

Figure 25. Schematic Diagram in Support of Step 3.

DESIGN SHEET	NOMENCLATURE STAGE LATCH ACTUATOR UNIT	CE: NO. OR CRITICAL COMPONENT CODE IDENTIFICATION 124020A DETAIL SPEC NO. _____
REQUIREMENTS FOR DESIGN AND TEST		
<p>3. Requirements</p> <p>3.1 Performance</p> <p>3.1.1 Functional Characteristics</p> <p>The stage latch actuating unit shall assure positive assembly of stages 1 and 2 and shall also function to properly unlock the stages upon receipt of the proper command.</p> <p>3.1.1.1 Primary Performance Characteristics</p> <ol style="list-style-type: none"> The stage unlocking function must be completed in 200 milliseconds from the time of unlock command. The unlock command shall consist of a 28 VDC \pm 1.5 VDC pulse of 25 ms \pm 1.5 ms duration. Zero-time shall be the time at which the command pulse reaches .90 of the minimum voltage amplitude limit. Power to accomplish the unlocking function shall be obtained from a primary vehicle source. A positive mechanical lock mechanism shall be provided. <p>3.1.1.2 Secondary Performance Characteristics</p> <p>FUNCTION 1.1.2.15</p> <ol style="list-style-type: none"> The stage latch actuating unit shall contain mechanical latches actuated by a pneumatic valve with the pneumatic energy being provided from a pressure storage flask containing helium. Pressurized helium shall be released by an explosive valve to actuate the unfastening mechanism. Pneumatic energy released at the separation signal shall cause four pneumatic actuators to retract staging latches from the stage 2 assembly. A push rod shall connect the actuator with the latches. The actuators shall consist of a cylinder and piston assembly. Piston travel shall cause the required push rod/latch motion to effect separation. The stage latches shall be caused to rotate by the push rod motion to achieve disengagement from the latch striker assembly. Rotation shall not exceed 30°. The force provided by an actuator to overcome the latch grasp of separation shall not exceed 200 pounds. The weight of helium bled from the A/B pneumatic manifold to power the stage latch actuating unit shall not exceed 0.250 pounds. Stage latch actuator unit pneumatic pressure decay shall not exceed 100 psi per hour. The decay rate shall not degrade the primary performance characteristics. <p>3.1.2 Operability</p> <p>3.1.2.1 Reliability</p> <p>The MTBF for the stage latch actuating unit in the operational mode, i.e., from helium tank pressurized to a point before stage latch unlock command, shall be 24 hours + 1 hour or shall be 10 pressurize-depressurize cycles, whichever occurs first. The MTBF for the unit in the actuate mode, i.e., from stage latch unlock command to stage latches unlocked, shall be twenty (20) seconds, or shall be one valve operating cycle, whichever occurs first.</p>		

REVISION C APPROVAL J. SHOOK DATE 20 May 1964 PAGE NO. 1 OF 11

Figure 26. Step 4 of System Engineering Management Process.

DESIGN SHEET	NOMENCLATURE STAGE LATCH ACTUATOR UNIT	CEI NO. OR CRITICAL COMPONENT CODE IDENTIFICATION <u>124020A</u> DETAIL SPEC NO. _____
REQUIREMENTS FOR DESIGN AND TEST		
<p>3.1.2.2 Maintenance</p> <p>FUNCTION 3.1.2.2.1 Maintainability</p> <p>1.1.2.14 a) The mean time to replace any one component of the stage latch actuating unit identified in paragraph 3.1.2.2.3 shall not exceed 30 man-minutes.</p> <p>b) The pneumatic actuators, the pneumatic regulator, and the pneumatic pressure sensor shall be the only components subject to organizational maintenance.</p> <p>3.1.2.2.2 Maintenance Repair Cycle</p> <p>a) The pressure sensor shall be calibrated each 1000 installed hours.</p> <p>b) The pressure regulator shall be calibrated each 2000 installed hours.</p> <p>c) A helium leak check shall be conducted following removal and replacement of any component.</p> <p>d) The pneumatic actuators and the pressure regulator shall be subject to a field maintenance/overhaul cycle following each installed period of 12 months.</p> <p>3.1.2.2.3 Service and Access</p> <p>a) The release valve, the pneumatic actuators, the pressure regulator, the pressure flask and the pressure sensor shall all be readily accessible for replacement and/or repair.</p> <p>b) The components of the stage latch actuating unit shall be packaged to assure removal of individual components without interference with other components of the complete assembly or other parts within quadrant 3.</p> <p>c) Provision shall be made to retain the airborne pneumatic system pressure if it is necessary to replace the stage latch actuator components. A shut-off valve shall be installed between the airborne pneumatic manifold and the pressure flask to accomplish this requirement.</p> <p>d) Provision shall be made to vent pneumatic pressure from the stage latch actuator unit.</p> <p>e) The stage latch actuator vent valve shall be interlocked with the airborne pneumatic system supply shut-off valve. The interlock shall prevent opening the vent valve while the airborne pneumatic system supply valve is open.</p> <p>f) The stage latch actuator unit shall be depressurized during any actions requiring removal and replacement of any component.</p> <p>g) A switch shall be installed in the common power lead to the explosive valve to prevent damage to the equipment or injury to personnel when the latch mechanism is being inspected or repaired. The switch shall have the capability of grounding the explosive valve power input terminal while in the power disconnect position. The switch shall be constructed to provide make-before-break capability during both the connect and disconnect actuations.</p> <p>3.1.2.3 Useful Life</p> <p>a) The pressure flask shall have an operating life of 5000 hours in the pressurized mode.</p> <p>b) The service life of all components of the stage latch actuator unit</p>		

REVISION C APPROVAL _____ DATE 20 MAY 1966 PAGE NO. 2 OF 11

Figure 26 (Continued). Step 4 of System Engineering Management Process.

DESIGN SHEET	NOMENCLATURE STAGE LATCH ACTUATOR UNIT	CEI NO. OR CRITICAL COMPONENT CODE IDENTIFICATION 124020A DETAIL SPEC NO. _____
REQUIREMENTS FOR DESIGN AND TEST		
<p style="text-align: center;">shall be six (6) years, except for maintenance parts such as O-rings and seals.</p> <p>3.1.2.4 Environment</p> <p>3.1.2.4.1 Natural Environment</p> <p>The stage latch actuating unit shall be capable of operating satisfactorily during or following the following natural environmental conditions:</p> <ol style="list-style-type: none"> a) Atmospheric Pressure: 30.5 in. Hg to 10.0 in. Hg b) Ambient Temperature: 30°F to 120°F c) Humidity: 100% R.H. d) Dirt, Dust, Sand: Particles at velocities up to 100 ft/sec and densities up to 2 ounces/ft³ /sec. e) Solar Heating: Standard BTU/ft² /hr. f) Salt Atmosphere: Exposure for periods up to 1000 hours. <p>3.1.2.4.2 Induced Environment</p> <p>The stage latch actuating unit shall be capable of operating satisfactorily during or following the following induced environmental conditions:</p> <ol style="list-style-type: none"> a) Temperature: -30°F to 220°F (parts exposed to atmosphere), - 60°F to 160°F (parts within thrust section). b) Atmospheric Pressure: 30.5 in. Hg to 1.0x10⁻⁶ in. hg. c) Vibration: 10 to 1000 cp; @ 2.5 g. RMS d) Acceleration: 3.5G + 0.0G - 3.5G e) Radiation, Space: Nominal for altitudes less than 1.0 X 10⁶ feet; mean time of exposure less than 60 seconds ± 5 sec. f) RF fields: less than 0.1 v/meter <p>3.1.2.5 Transportability</p> <ol style="list-style-type: none"> a) Performance of the installed stage latch actuating unit shall not be degraded by transport vibration, shock, or other environment. b) Performance of individual components shall not be degraded by transport vibration, shock, or other environment. c) Transport media appropriate to (a) shall be limited to (1) air transport and (2) ground-handling trailer. d) Transport media appropriate to (b) shall be (1) air transport, (2) motor carrier, (3) lift-truck, (4) hand-truck, (5) hand-carry. e) Appropriate existing packaging and packing methods shall be employed to satisfy requirements of (b). Ref.: MIL-P-7936. <p>3.1.2.6 Human Performance - Not applicable.</p> <p>3.1.2.7 Safety</p> <p>3.1.2.7.1 Personnel Safety</p> <ol style="list-style-type: none"> a) The pressure flask assembly shall be prominently marked to indicate the danger of explosion if not depressurized prior to removal. b) Electrical continuity of the explosive valve igniter circuit shall be checked by using only a type PCT-801B pyrotechnic circuit tester. c) The explosive valve electrical connector shall be equipped with a shorting device installed on the electrical connector contacts to prevent valve actuation from high-energy radio frequency fields. The shorting plug shall be removed only for purposes of checking electrical continuity or for purposes of installing the valve electrical connector. At all other times the shorting plug shall be installed. 		

REVISION C APPROVAL _____ DATE 20 MAY 1964 PAGE NO. 3 OF 11

Figure 26 (Continued). Step 4 of System Engineering Management Process.

DESIGN SHEET	NOMENCLATURE STAGE LATCH ACTUATOR UNIT	CEI NO. OR CRITICAL COMPONENT CODE IDENTIFICATION <u>121020A</u> DETAIL SPEC NO. _____
--------------	---	---

REQUIREMENTS FOR DESIGN AND TEST

d. Other: See 3.1.2.2.3 c, d, e, f, j.
 3.1.2.7.2 Equipment Safety - Not applicable.
 3.1.2.8 Noise and Vibration
 Applicable acoustic induced vibration and mechanical vibration limits are specified in paragraph 3.1.2.4.2 c.

3.2 CEI Definition

FUNCTION 3.2.1 Interface Requirements
 1.1.2.7 a) The separation signal shall be as described in Para. 3.1.1.1 b.
 b) The helium interface connector shall be located on the stage separation panel.
 c) The latches shall be located as shown in drawing number _____ to properly engage the latch striker assembly.

3.2.1.1 Schematic Arrangement
 a) The schematic arrangement of the stage latch actuating unit shall be as shown on drawing number _____.
 b) Physical interfaces are as shown by drawing number _____.

3.2.1.2 Detailed Interface Definition
 a) The mechanical interfaces of the stage latch actuating unit are identified in drawings _____ and _____, and in Paragraph 3.1.1.2.
 b) Functional interfaces of the stage latch actuating unit are identified in paragraph 3.1.1.1, and in Engineering Document _____.

3.2.2 Component Identification

3.2.2.1 GFP List
 a) Explosive Valve Spec. No. _____
 Part No. _____

3.2.2.2 Engineering Critical Component List
 a) Pressure vessel
 b) Actuator

3.2.2.3 Logistic Critical Component List
 a) Pressure vessel
 b) Actuator
 c) Relief valve
 d) Explosive valve

3.3 Design and Construction

FUNCTION 3.3.1 General Design Features
 1.1.2.13 a) A pressure flask shall be employed to store helium at pressures not to exceed 600 psi and at temperatures not to exceed 120°F.
 b) The pressure flask shall be located in quadrant 3, approximately at station 1127. Mounting shall be by two brackets attached to the main vehicle frame.
 c) A pressure transducer shall be employed to provide a means of indicating vessel pressure at the ground monitor. An on/off indicating switch (for switching 28 VDC power), a momentary test switch, and a zero adjust potentiometer shall be provided for the pressure sensing network.
 d) The explosive valve shall be a single body of stainless steel with an electrically operated poppet interbody. The construction will allow rapid evaluation of the valve condition through use of pressure and voltage checking.

REVISION C APPROVAL _____ DATE 20 May 1966 PAGE NO. 1 OF 11

Figure 26 (Continued). Step 4 of System Engineering Management Process.

10 March 1966

DESIGN SHEET	NOMENCLATURE STAGE LATCH ACTUATOR UNIT	CEI NO. OR CRITICAL COMPONENT CODE IDENTIFICATION <u>124020</u> DETAIL SPEC NO. _____
REQUIREMENTS FOR DESIGN AND TEST		
<p>e) The pressure flask shall be constructed with a minimum of openings and welds. The construction shall allow rapid and effective evaluation of flask condition by use of X-ray and pressure inspection techniques.</p> <p>3.3.2 Selection of Specifications and Standards Specifications and Standards for parts and components of the stage latch actuating unit shall be selected in accordance with MIL-STD-143.</p> <p>3.3.3 Materials Parts and Processes</p> <ol style="list-style-type: none"> All fittings shall conform to the requirements of MIL-F-5509A. All pneumatic piping shall be identified in accordance with MIL-S-1247. The pneumatic system shall be sealed by the (x) process. <p>3.3.4 Standard and Commercial Parts</p> <ol style="list-style-type: none"> Maximum use shall be made of standard and commercial parts in the design of the stage latch actuating unit. All connectors on the pneumatic release valve shall comply with military standards for threads and fittings. <p>3.3.5 Moisture and Fungus Resistance</p> <ol style="list-style-type: none"> Fungus Resistance - Not applicable Moisture Resistance - Reference: 3.1.2.4.1 c. <p>3.3.6 Corrosion of Metal Parts Whenever dissimilar metals are in direct contact, suitable methods for controlling electrolytic corrosion shall be used, complying with MIL-F-7179. Ref: MS33526.</p> <p>3.3.7 Interchangeability and Replaceability All parts and assemblies of the stage latch mechanism shall meet the interchangeability requirements of MIL-I-8500.</p> <p>3.3.8 Workmanship The stage latch actuating unit including all parts and assemblies shall be constructed and finished in accordance with best commercial practices.</p> <p>3.3.9 Electromagnetic Interference/Susceptibility</p> <ol style="list-style-type: none"> Electromagnetic Interference - Not applicable. Electromagnetic Susceptibility. Means shall be provided to prevent detonation of the explosive valve from extraneous voltages induced in the wiring leading to the power input terminal. <p>3.3.10 Identification and Marking</p> <ol style="list-style-type: none"> Hazardous Conditions: Reference 3.1.2.7.1. a. Components shall be marked in accordance with MIL-STD-130. Fluid lines shall be banded in accordance with AND10375. <p>3.3.11 Storage The storage life of all components of the stage latch actuator unit shall be six (6) years, except for O-rings and seals made from organic materials, which shall have a storage life of 3 years.</p>		

REVISION C APPROVAL _____ DATE 20 May 1964 PAGE NO. 5 OF 11

Figure 26 (Continued). Step 4 of System Engineering Management Process.

10 March 1966

AFSCM 375-5

DESIGN SHEET	NOMENCLATURE STAGE LATCH ACTUATOR UNIT	CEI NO. OR CRITICAL COMPONENT CODE IDENTIFICATION <u>124020A</u> DETAIL SPEC NO. _____
--------------	---	---

REQUIREMENTS FOR DESIGN AND TEST

4. Quality Assurance Provisions

- a) Performance, design and construction requirements specified in Section 3. are formally verified by the provisions of this section. Formal verification shall establish acceptance of design and development engineering.
- b) Each requirement appearing in Section 3. is associated with:
 - (1) verification method (s)
 - (2) test categories
 - (3) subparagraphs of Section 4. where the verification of such Section 3. requirement has been accommodated.
- c) A reference Index provides for accountability of each Section 3. requirement and corresponding Section 4. verification provision. The index follows paragraph 4.2.

4.1 Category I Test

4.1.1 Engineering Test and Evaluation - Not applicable

4.1.2 Preliminary Qualification Tests

Preliminary qualification tests are performed to achieve interim acceptance of performance and design characteristics prior to utilization of the contract end item under one or more of the following conditions: a) Manned operations; b) Integrated testing with other equipments and/or with facilities; c) Committing the item to an extensive, costly qualification program.

4.1.2.1

(3.1.2.2.3.c)

Demonstrate provisions for retaining airborne system pneumatic pressure during maintenance operations.

4.1.2.2

(3.1.2.2.3.d)

Demonstrate provisions for preventing inadvertent operation of explosive valve during latch maintenance operations.

4.1.2.3

(3.1.2.2.3.4)

Demonstrate pressure relief provisions for the stage latch actuating unit helium pressure flask.

4.1.2.4

(3.1.2.2.3.e.f)

Demonstrate the interlock provisions for A/B helium system pressure valve open and stage latch actuator unit helium pressure flask vent valve open.

4.1.2.5

(3.1.2.7.1.a)

By inspection, verify presence and proper message content of warning markings on stage latch actuator unit pressure flask.

4.1.3 Formal Qualification Tests

Formal qualification tests are conducted to satisfy specific requirements of the procuring agency to verify that all requirements of Section 3. are satisfied. Accomplishment of the verifications constitutes acceptance of design and development engineering. Verifications are organized according to method of accomplishment. The methods are (1) inspection (2) review of analytical data (3) demonstration and (4) test.

REVISION C APPROVAL _____ DATE 20 May 1966 PAGE NO. 6 OF 11

Figure 26 (Continued). Step 4 of System Engineering Management Process.

10 March 1966

DESIGN SHEET	NOMENCLATURE STAGE LATCH ACTUATOR UNIT	CEI NO. OR CRITICAL COMPONENT CODE IDENTIFICATION <u>124020A</u> DETAIL SPEC NO. _____
REQUIREMENTS FOR DESIGN AND TEST		
<p>4.1.3.1 Inspection The following requirements of Section 3 shall be verified by inspection of the CEI at time and place of qualification testing.</p> <p>a) (3.2.1.1; 3.3.1.b) Schematic arrangement of stage latch actuating unit referenced to Dwg. No. _____.</p> <p>b) (3.2.2) Randomly selected components/parts of the stage latch actuating unit will be compared against provisions of MIL-STD-145.</p> <p>c) (3.3.3.a) Randomly selected fittings will be compared for conformance to requirements of MIL-F-5509A.</p> <p>d) (3.3.3.b) Pneumatic piping identification will be compared against requirements of MIL-S-1247.</p> <p>e) (3.3.3.c) Pneumatic system sealing process will be examined for conformance with Process Std 30122.</p> <p>f) (3.3.4.a) The utilization of standard and commercial parts in the design of the stage latch actuating unit shall be verified.</p> <p>g) (3.3.4.b) Pneumatic release valve connectors shall be examined for conformance to MIL-P-8564.</p> <p>h) (3.3.6) Metallic interfaces shall be verified to conform with MIL-F-7179 and MS33586, electrolysis control.</p> <p>i) (3.3.7) Random selections of parts and assemblies shall be made by the qualification team to establish conformance with provisions of MIL-I-3500.</p> <p>j) (3.3.8) Construction and finish of the stage latch actuating unit shall be verified to conform to best commercial assembly and process practices.</p> <p>k) (3.3.10) Conformance to MIL-STD-130 for identification and marking of components and assemblies of the stage latch actuating unit shall be verified.</p> <p>l) (3.2.2.1) Verify installation of correct government furnished parts.</p> <p>4.1.3.2 Review of Analytical Data</p> <p>a) (3.1.2.1; 3.1.2.3) Review accumulated stage latch actuator unit longevity data. The data shall differentiate between periods of</p> <ol style="list-style-type: none"> (1) Unit de-energized (no helium) (2) Unit energized (helium loaded) (3) Unit activated (valve released) <p>b) (3.1.1.1; 3.1.1.2; 3.1.2.4.1; 3.1.2.5) Review analytical data to verify performance characteristics are acceptable</p>		

REVISION C APPROVAL _____ DATE 20 May 1964 PAGE NO. 7 OF 11

Figure 26 (Continued). Step 4 of System Engineering Management Process.

DESIGN SHEET	NOMENCLATURE STAGE LATCH ACTUATOR UNIT	CEI NO. OR CRITICAL COMPONENT CODE IDENTIFICATION <u>12 020</u> DETAIL SPEC NO. _____
REQUIREMENTS FOR DESIGN AND TEST		
<p>Following exposure to transport shocks, loads, and environments.</p> <p>c) (3.1.1.2.6) Explosive valve flow parameters shall be verified by review of GTP data.</p> <p>d) (3.1.2.3.a; 3.3.1.a) Pressure flask operating life shall be verified by review of vendor data on similar pressure vessels.</p> <p>e) (3.1.2.3.b) Explosive valve service life shall be verified by review of GTP data.</p> <p>f) (3.1.2.2.1; 3.1.2.2.2; 3.1.2.2.3) Systems engineering maintainability documentation is to be reviewed to compare predicted failure modes against failure data accumulated during development. Maintenance periods for developmental failures are to be compared against predicted maintenance time requirements.</p> <p>4.1.3.3 Demonstrations Demonstrations related to maintainability shall be accomplished in accordance with following provisions:</p> <p>a) (3.1.2.2.3a) Demonstrate the accessibility of the stage latch actuator components for repair and replacement.</p> <p>b) (3.1.2.2.3b through 3.1.2.2.3c; 3.1.2.7) Demonstrate provisions for removal of stage latch actuator components without interference with other components of the complete assembly or other parts within q3, by performing one complete maintenance inspection for the stage latch actuating unit.</p> <p>c) (3.3.1.d) Demonstrate explosive valve physical condition evaluation process by use of pressure and voltage checks.</p> <p>d) (3.3.1.e) Demonstrate evaluation of pressure flask physical condition through use of pressure and X-ray techniques.</p> <p>e) (3.2.1a) Demonstrate electrical interface capability.</p> <p>f) (3.2.1b) Demonstrate pneumatic interface capability.</p> <p>g) (3.2.1c) Demonstrate mechanical interface capability.</p> <p>4.1.3.4 Tests</p> <p>a) (3.1.1.1 and 3.1.1.2) Obtain statistical data to verify overall design adequacy and conformance to functional requirements.</p> <p>b) (3.1.1.1; 3.1.1.2; 3.1.2.4.1) Obtain statistical data to verify performance characteristics are not degraded by exposure to natural environments.</p> <p>c) (3.1.1.1; 3.1.1.2; 3.1.2.4.2; 3.3.9) Obtain statistical data to verify performance characteristics are not degraded by exposure to induced environments.</p> <p>d) Data required under 4.1.3.4 shall be acquired through ground environmental</p>		

REVISION C APPROVAL _____ DATE 20 Mar 1966 PAGE NO. 3 OF 11

Figure 26 (Continued). Step 4 of System Engineering Management Process.

DESIGN SHEET	NOMENCLATURE STATE LATCH ACTUATOR UNIT	CEI NO. OR CRITICAL COMPONENT CODE IDENTIFICATION <u>224020A</u> DETAIL SPEC NO. _____
REQUIREMENTS FOR DESIGN AND TEST		
<p>tests, environmental simulation tests, and flight tests. One article shall be employed for ground and simulated environment tests. Three samples of data from flight testing shall be provided from category I testing specified for CEI 4030, and two samples of data shall be provided from category I increased flight testing of CEI 4030 with CEI 4010.</p> <p>a) The zero time reference shall be the time at which the release signal acquires a value of 23.05 VDC; i.e., 0.00 Sec.</p> <p>b) State latch actuator release shall be considered executed when the latch lip has a clearance of 0.1250 inches with the latch striker. The release signal and the latch lip release are generated by the motion of the latch about the latch pivot.</p> <p>c) State latch actuator unit parameters to be sampled shall consist of the following:</p> <ol style="list-style-type: none"> (1) Pressure vessel fill time referenced to A/B pneumatic manifold relief load start signal. (2) Pressure vessel relief temperature and pressure during <ol style="list-style-type: none"> (a) load (c) post-load to valve activate (3) Pneumatic actuator extension position in respect to release signal zero time. (4) Pneumatic actuator force in respect to zero time reference. (5) Release latch angular position and latch lip motion in respect to zero time reference. (6) Pressure regulator inlet and outlet pressures. <p>d) Appropriate small sample statistical tests shall be conducted on the data.</p> <p>4.1.4 Reliability Test and Analysis</p> <p>a) (3.1.2.1) Sufficient reliability data is acquired from historical data and through testing required by 4.1.1, 4.1.2, 4.1.3.2 and 4.1.3.4 to preclude the necessity for additional tests to acquire reliability data.</p> <p>4.1.5 Engineering Critical Component Qualification (3.2.2.2) Qualification requirements for each Engineering Critical Component are contained in the referenced specification.</p> <p>Pressure Vessel Spec. _____ Actuator Spec. _____</p> <p>4.2 Category II Test</p> <p>a) (3.1.2.2.1; 3.1.2.2.2; 3.1.2.2.3; 3.1.2.7.1) Perform randomly selected maintenance cycle operations employing appropriate technical manuals and personnel.</p> <p>b) (3.3.1.c) Demonstrate operation of the tank pressure ground monitor, including operation of all controls and indicators.</p>		

REVISION C APPROVAL _____ DATE 20 MAR 1966 PAGE NO. 9 OF 11

Figure 26 (Continued). Step 4 of System Engineering Management Process.

10 March 1966

AFSCM 375-

DESIGN SHEET	NOMENCLATURE STAGE BENCH ACTUATOR UNIT	CEILING OR CRITICAL COMPONENT CODE IDENTIFICATION 124020 DETAIL SPEC NO. _____
--------------	---	---

REQUIREMENTS FOR DESIGN AND TEST

VERIFICATION CROSS REFERENCE INDEX

METHOD LEGEND: N/A. - Not Applicable

2- Review of Analytical Data

1- Inspection

3- Demonstration

- Test

TEST. C. LEGEND: A - Engineering Test & Evaluation

B - Preliminary Qualification

C - Formal Qualification

D - Reliability Test & Analysis

E - Engineering Detailed Component Qualification

SECTION 3. REQUIREMENT REFERENCE	VERIFICATION METHOD (3)					TEST CATEGORY						SECTION 4. VERIFICATION REQUIREMENT
	N/A	1	2	3	4	A	B	C	D	E	II	
3.	☐											
3.1	☐											
3.1.1	☐											
3.1.1.1			☐					☐				4.1.3.2.b
3.1.1.2			☐					☐				4.1.3.4.a,b,c
3.1.2	☐							☐				4.1.3.2.b,c
3.1.2.1			☐					☐				4.1.3.4.a,b,c,
3.1.2.2	☐								☐			4.1.3.2.a
3.1.2.2.1			☐									4.1.3.2.a
3.1.2.2.2	☐											4.1.3.2.f
3.1.2.2.3			☐									4.2.a
3.1.2.2.4			☐		☐							4.1.3.2.f
3.1.2.2.5			☐		☐							4.2.a
3.1.2.2.6			☐		☐			☐				4.1.2.1,2,3,4
3.1.2.2.7			☐		☐			☐				4.1.3.2.f
3.1.2.2.8			☐		☐			☐				4.1.3.3.a,b
3.1.2.3			☐		☐							4.2.a
3.1.2.4	☐							☐				4.1.3.2.a,d,e
3.1.2.4.1			☐					☐				4.1.3.2.b
3.1.2.4.2			☐					☐				4.1.3.4.b
3.1.2.5			☐					☐				4.1.3.4.c
3.1.2.6	☐											4.1.3.2.b
3.1.2.7	☐											
3.1.2.7.1			☐					☐				4.1.2.5
3.1.2.7.2			☐								☐	4.2.a
3.1.2.8	☐											
3.2	☐											

REVISION C APPROVAL _____ DATE 20 May 1964 PAGE NO. 10 OF 11

Figure 26 (Continued). Step 4 of System Engineering Management Process.

DESIGN SHEET	NOMENCLATURE SPACE LAUNCH ACTUATOR UNIT					CEI NO OR CRITICAL COMPONENT CODE IDENTIFICATION 17 020A DETAIL SPEC NO. _____						
REQUIREMENTS FOR DESIGN AND TEST												
VERIFICATION CROSS REFERENCE INDEX												
METHOD LEGEND: N.A. - Not Applicable 1- Inspection 2- Review of Analytical Data 3- Demonstration -Test												
SMT. I. LEGEND: A - Engineering Test & Evaluation B - Preliminary Qualification C - Formal Qualification D - Reliability Test & Analysis E - Engineering Critical Component Qualification												
SECTION 3. REQUIREMENT REFERENCE	VERIFICATION METHOD (C)					TEST CATEGORY I					SECTION 4. VERIFICATION REQUIREMENT	
	NA	1	2	3	-	A	B	C	D	E		II
3.2.1								X				-1.3.3.e,f,g -1.3.1.a
3.2.1.1		X						X				
3.2.1.2								X				
3.2.2								X				-1.3.1.1
3.2.2.1								X				-1.5
3.2.2.2								X				
3.2.2.3								X				
3.3	X											
3.3.1												-1.3.1.a
								X				4.1.3.2.d
								X				4.1.3.3.c,d
								X			X	4.2.b
3.3.2												-1.2.1.b
3.3.3								X				-1.3.1.c,d,e
3.3.4								X				4.1.3.1.f,g
3.3.5	X											
3.3.6								X				4.1.3.1.h
3.3.7								X				4.1.3.1.i
3.3.8								X				4.1.3.1.j
3.3.9								X				4.1.3.1.c
3.3.10								X				4.1.3.1.k
3.3.11	X											

REVISION _____ APPROVAL _____ DATE 20 May 1964 PAGE NO. 11 OF 11

Figure 26 (Continued). Step 4 of System Engineering Management Process.

10 March 1966

AFSCM 375-

2.0 TOP LEVEL FUNCTIONAL FLOW BLOCK DIAGRAMS FOR A SPACE SYSTEM AND A MISSILE SYSTEM:

2.1 Figure 27. Figure 27 shows an example of a top-level functional diagram for a missile (mobile type) system. The diagram contains the gross functions which must be accomplished to meet system objectives. The function num-

bers on the top-level functional diagrams arbitrarily indicate the relative importance and sequence of preparing lower level diagrams; e.g., function 1.0 would be expanded first, then function 2.0, and 3.0, etc.

2.2 Figure 28. Figure 28 shows an example of a top- and first-level functional diagram for a 6XX orbiting space system.

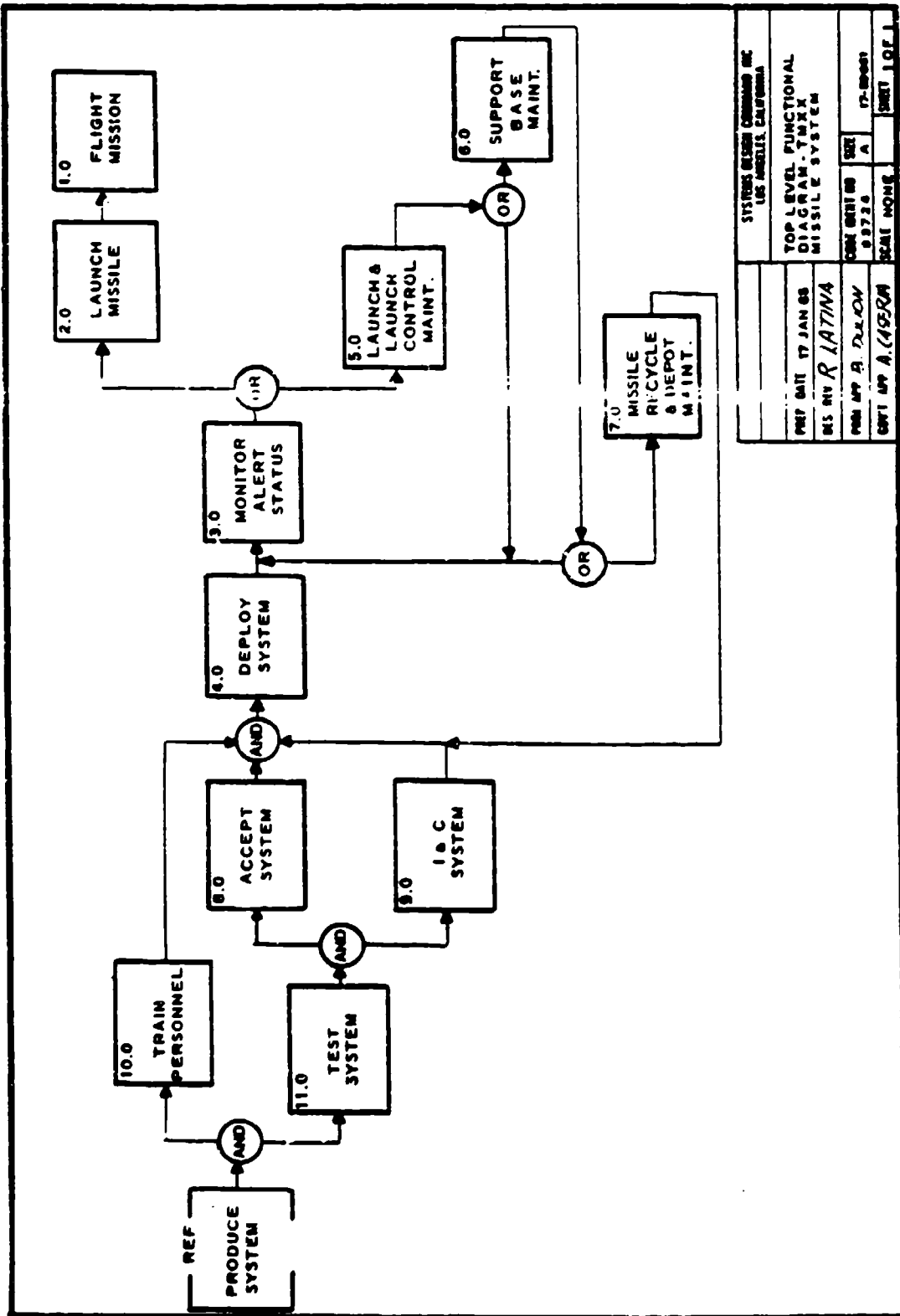
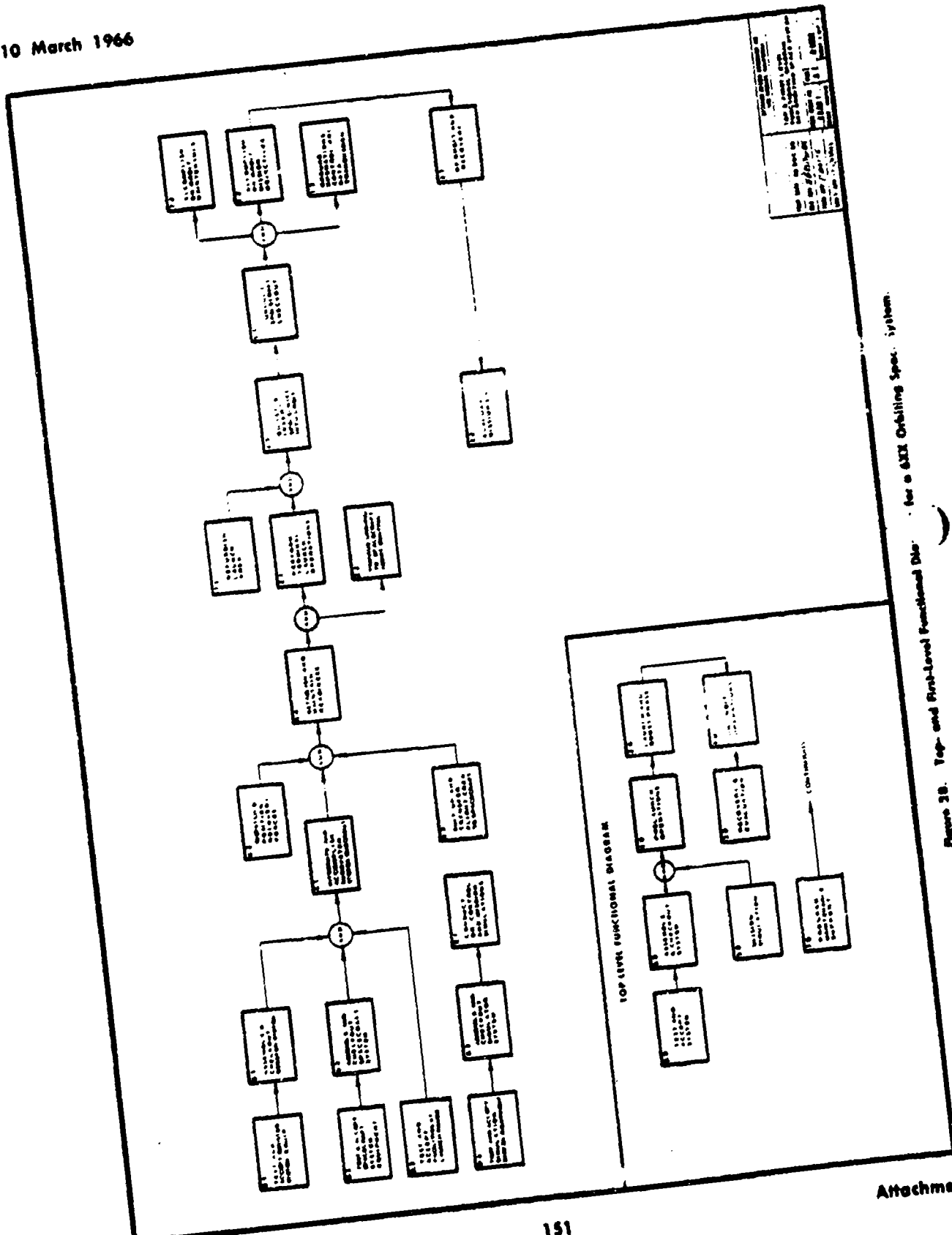

Figure 27. Top-Level Functional Diagram for a TALLIX Missile System.

10 March 1966

AFSCM 375-



Attachment 2

Figure 28. Top- and First-Level Functional Diagram for 63X Orbiting Spec. System.

3.0 ELECTRONIC SYSTEM FUNCTIONAL FLOW BLOCK DIAGRAMS. Figures 29 and 31 provide examples of functional diagrams as applied to a 4XXL electronic system.

3.1 Figure 29. Figure 29 shows the gross functions required to totally satisfy the mission of the system and the relationships between these functions.

3.2 Figure 30. Figure 30 shows the first-level expansion of top-level function 5.0, "strike effect evaluation."

3.3 Figure 31. Figure 31 shows a second-level expansion of first-level function 5.2, "strike report verification," and includes the identification of data input/output and data files supporting each function.

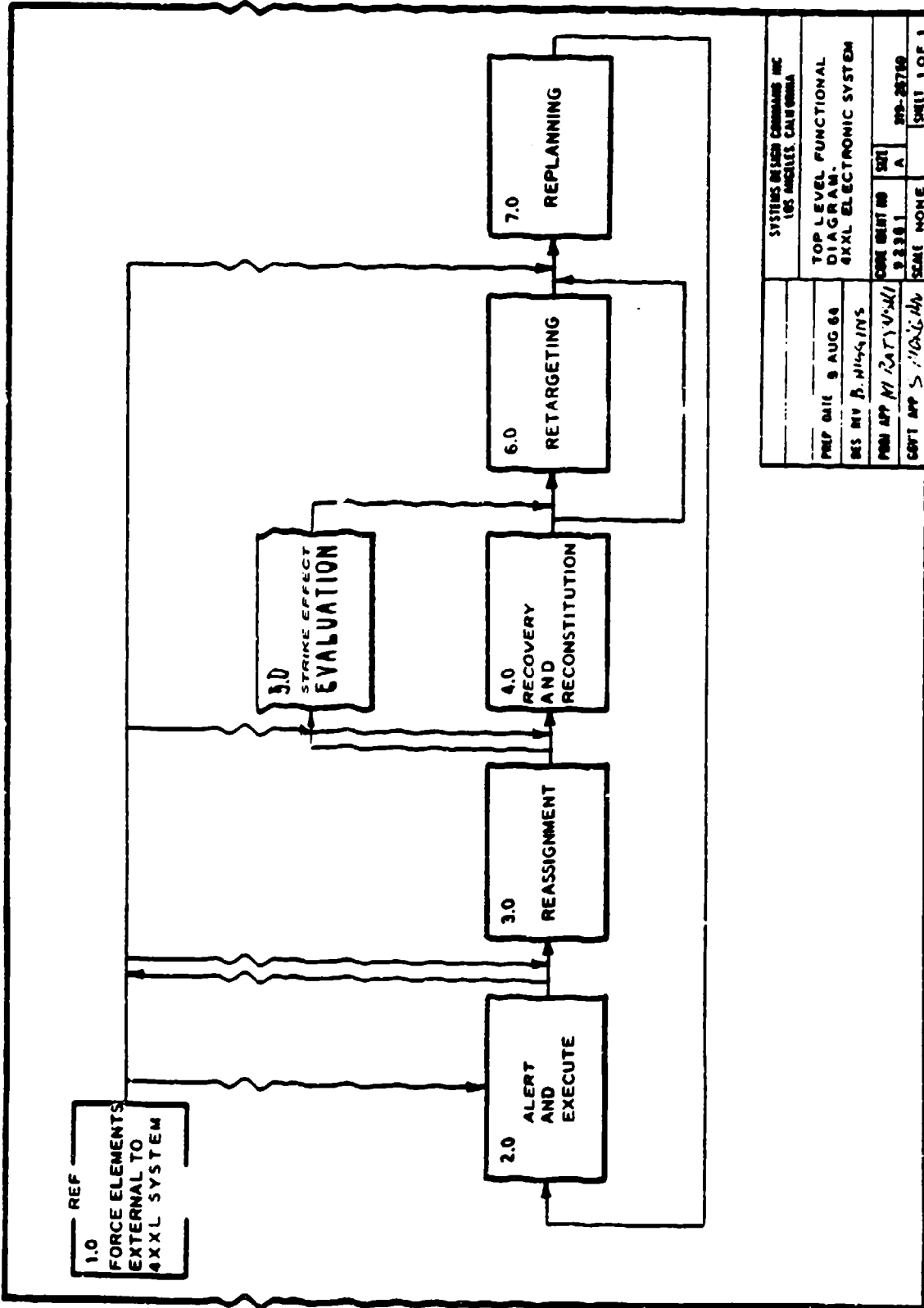

SYSTEMS DESIGN COMPANY INC LOS ANGELES, CALIFORNIA			
TOP LEVEL FUNCTIONAL DIAGRAM - 4XXL ELECTRONIC SYSTEM			
PREP DATE	9 AUG 64	CORE UNIT NO	SU1
DES BY	B. HIGGINS	9 2 3 8 1	A
PROJ APP	M. RATYNSKI	SCALE	NONE
COPY APP	S. D. J. J.	SHEET	1 OF 1

Figure 29. Top-Level Functional Diagram for a 4XXL Electronic System.

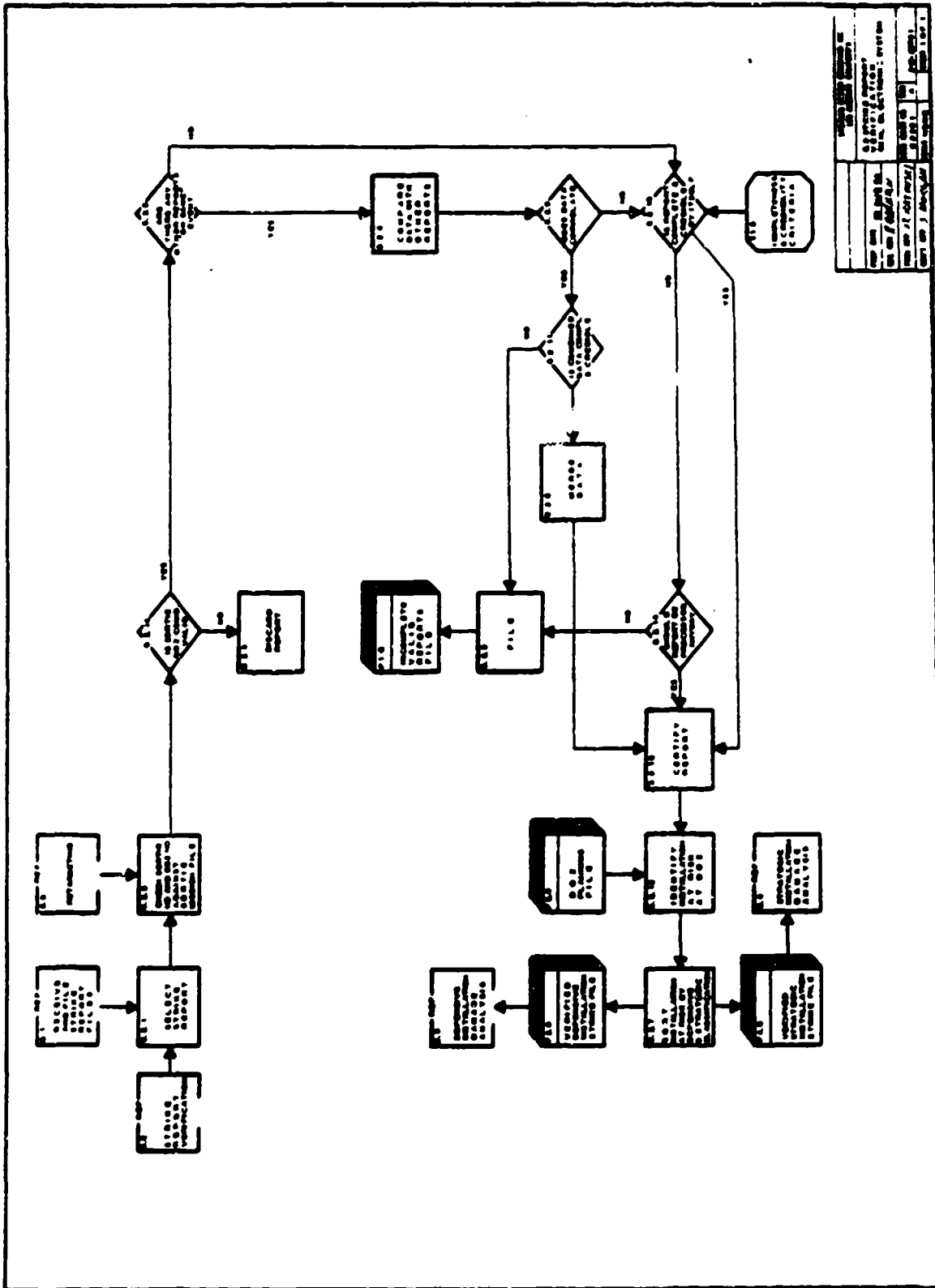

Figure 31. Second-Level Functional Diagram for a 4028 Electronic System.

4.0 AERONAUTICAL SYSTEM FUNCTIONAL FLOW BLOCK DIAGRAMS:

4.1 Figure 32. Figure 32 shows an example of a top-level functional diagram for an F2XX aeronautical system. The diagram contains the gross functions which must be accomplished to meet system objectives.

4.2 Figure 33. Figure 33 shows the first-level expansion of top-level function 1.0, "Tactical operations."

5.0 FACILITY FUNCTIONAL FLOW BLOCK DIAGRAMS:

5.1 Figure 34. Figure 34 shows an example of a second-level functional diagram for facilities, which expands the first-level function 8.1, "Maintain fixed and protective environment."

5.2 Figure 35. Figure 35 shows a third-level functional diagram expanding the second-level function 8.1.1, "Generate and distribute power."

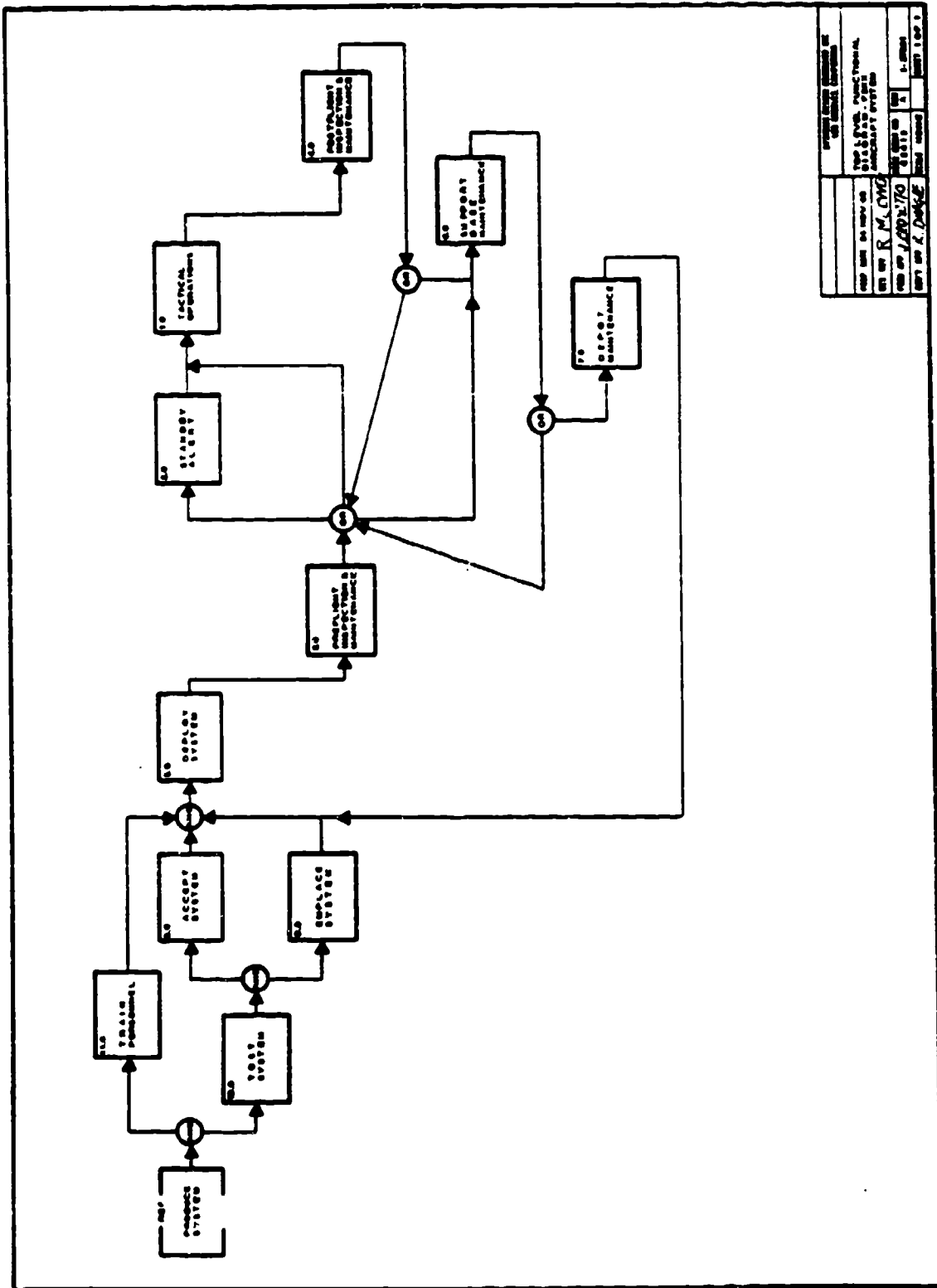

Figure 21. Top-Level Functional Diagram for an F2X Acceleration System.

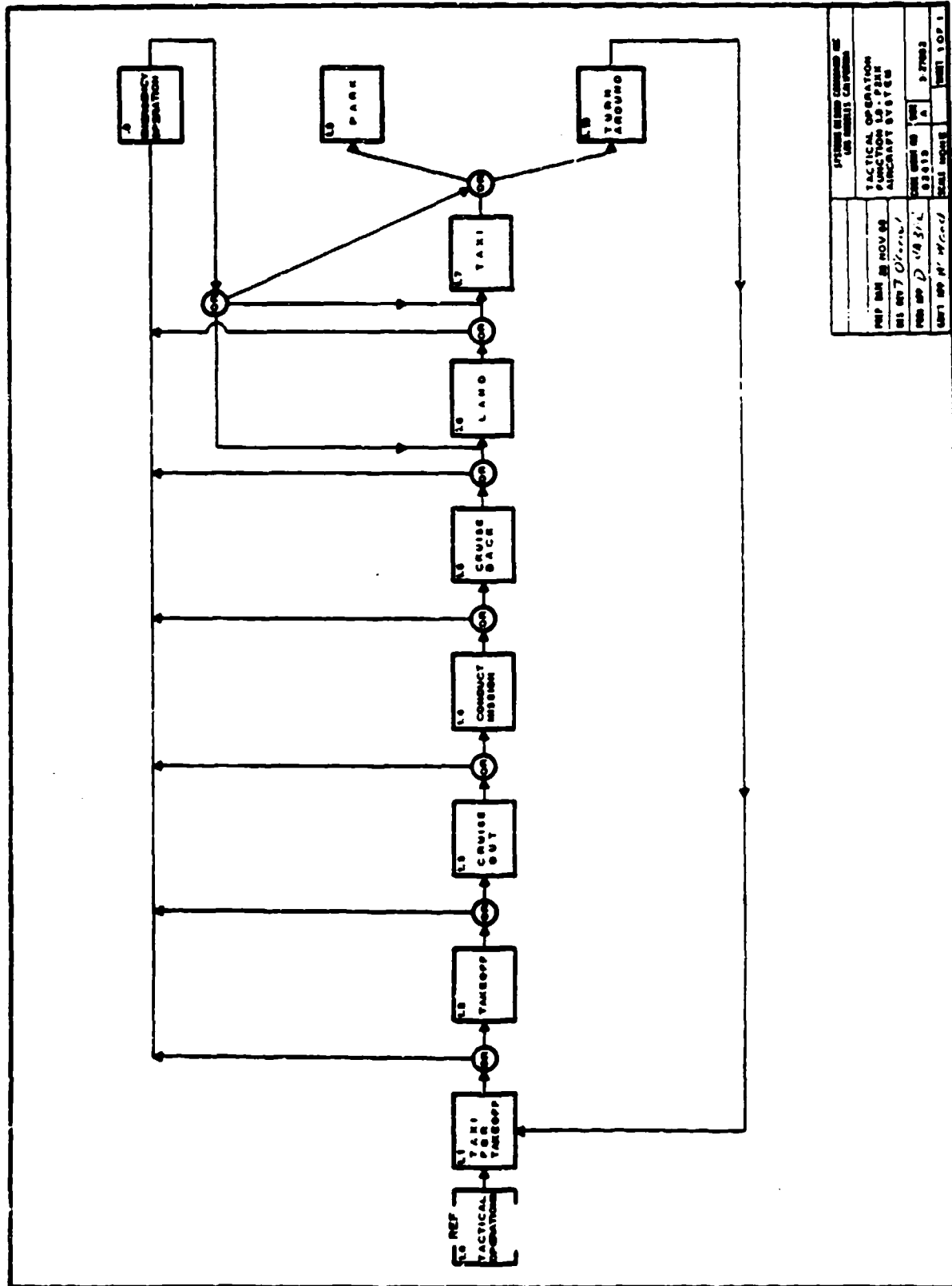

Figure 33. First-Level Functional Diagram for an F22X Aeronautical System.

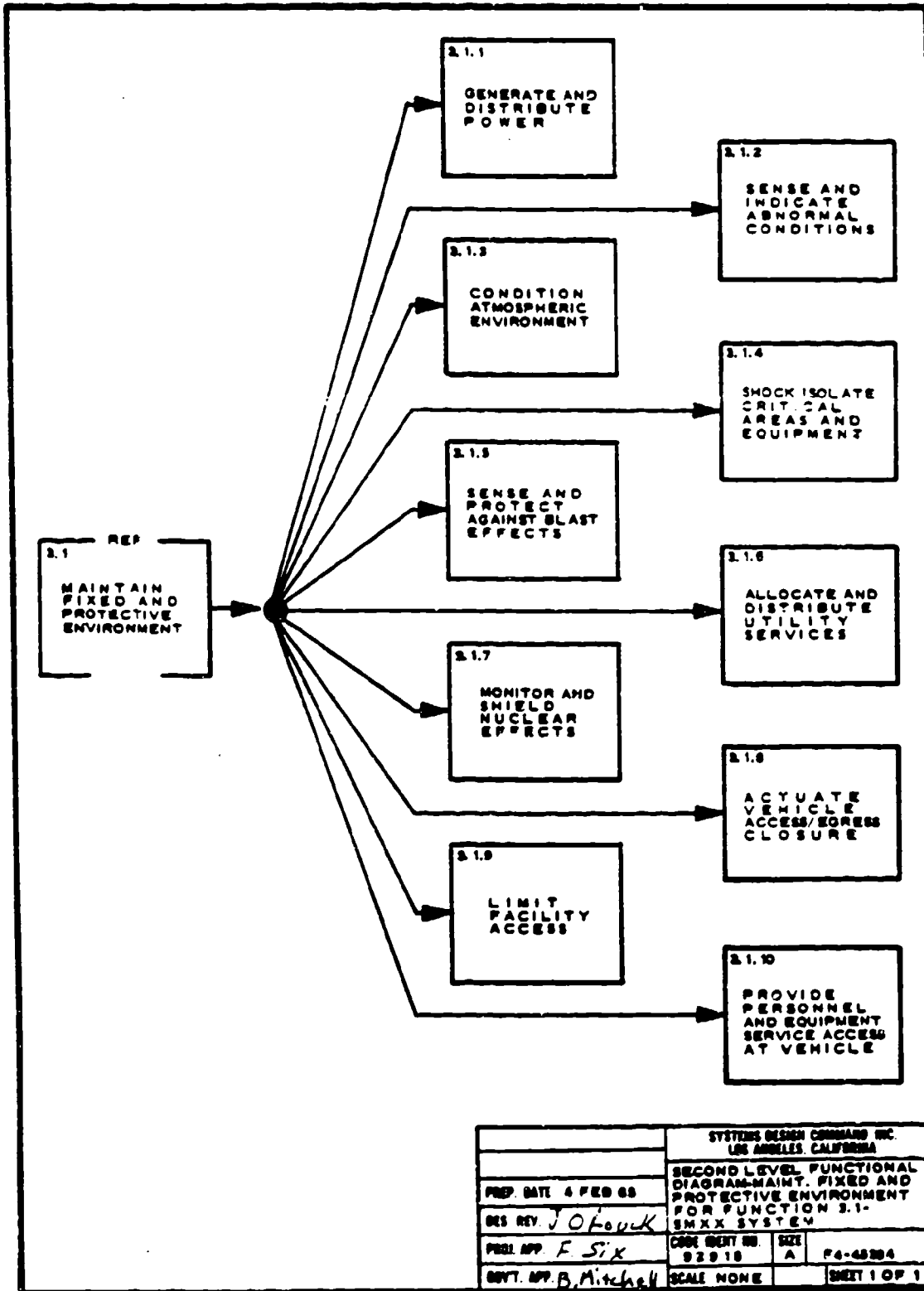
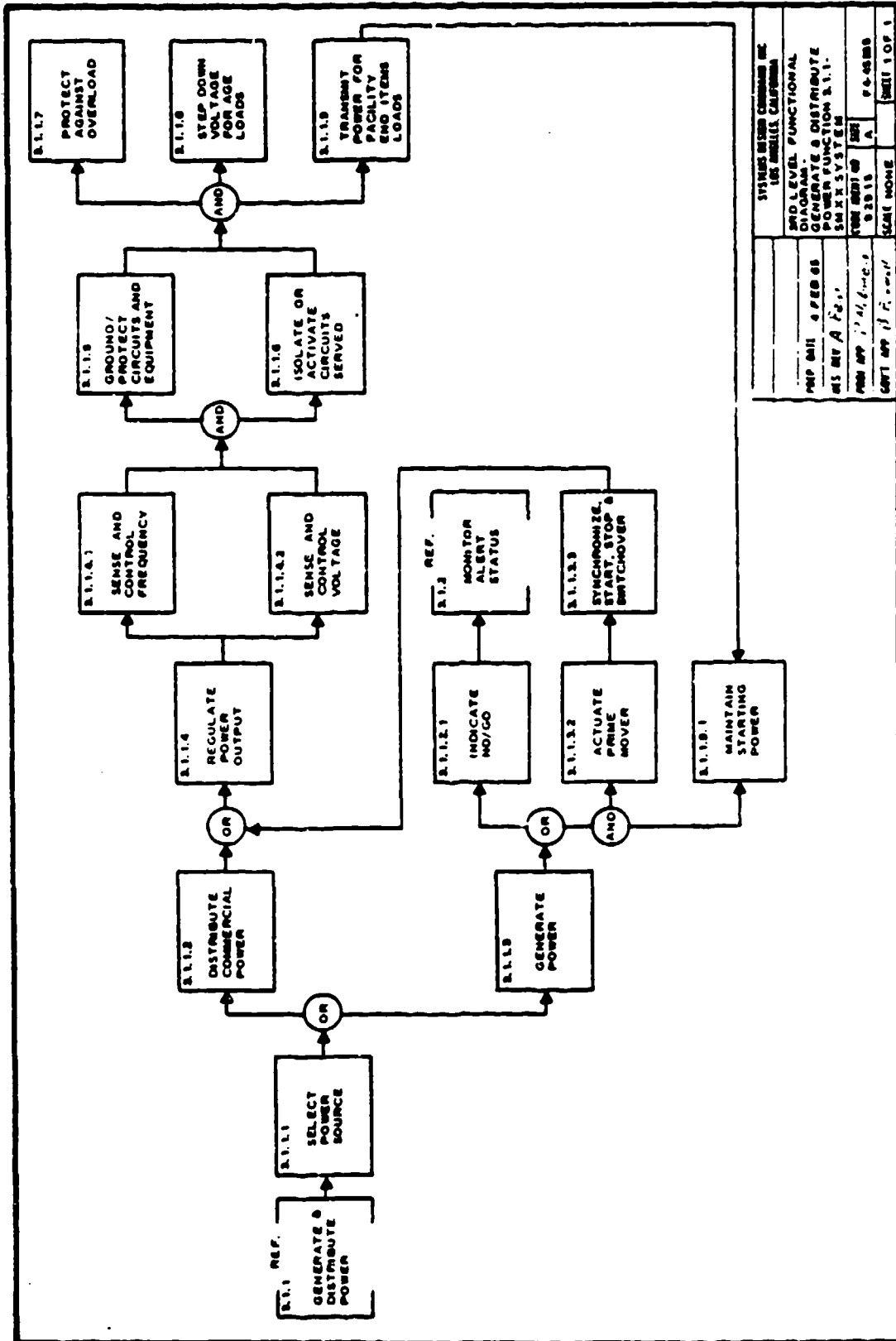

Figure 34. Second-Level Functional Diagram for Facilities to Support the SMOX System.



SYSTEMS DESIGN COMMANDER MC LOS ANGELES CALIFORNIA			
3RD LEVEL FUNCTIONAL DIAGRAM			
REF NO	4 FEB 66	GENERATE & DISTRIBUTE POWER FUNCTION 3.1.1.	
DES BY	A. P. J.	SMAX SYSTEM	
FORM NO	7-41, 6-65	FORM NO	7-41, 6-65
SCALE	1:1	SCALE	1:1

Figure 35. Third-Level Functional Diagram for Facilities to Support SMAX System.

10 March 1966

AFSCM 375-5

6.0 REQUIREMENTS ALLOCATION SHEET:

6.1 Figures 36 and 37. Figure 36 is an example of a requirements allocation sheet (RAS) which would be completed at the point of block 22 of exhibit I. Figure 37 shows the functional diagram containing the functions which have

been translated into design requirements on the RAS.

6.2 Figure 38. Figure 38 is another example of a requirements allocation sheet (RAS) showing more detailed information in the facilities, personnel, and training areas.

Function Name & Number	Foothead Diagram Title and No. _____ Incorporates and Number (SAC) (S) _____ or _____ Manufacturers and No. of CR		Equipment Identification		PERSONNEL AND TRAINING EQUIPMENT REQUIREMENTS				Procedural Basic Requirements
	Design Requirements	Facility Requirements	Non-disturb	CEI or Disturb Index or Master Control Number	Tests	Time Req	Performance Requirements	Ing & Top Equip Req	
4.2 Function Name & Number									
4.4 Function Name & Number									

Page Number 1 of 1

Document Number 4814

Approval _____

Date 10 March 1966

Figure 26. BAS for the Function "Integrates and Service SSI's."

FUNCTIONAL BIODIAGNOSTIC AND NO. OF PERSONNEL AND TRAINING EQUIPMENT REQUIREMENTS	REQUIREMENTS ALLOCATION SHEET		Facility Requirements		Equipment Identification		PERSONNEL AND TRAINING EQUIPMENT REQUIREMENTS				Procedural Data Requirements	
	Function Name & Number	Design Requirements	Design Requirements	Facility Requirements	Name-Status	CEI or Detail Index or Master Control Number	Tasks	Time Req	Performance Requirements	Ins & Tool Equip Req		
1.0 1.0.1 1.0.2 1.0.3	<p>1.0.1.1. The design shall provide for the generation, storage, and retrieval of test data. This requirement is satisfied by the design of the test equipment.</p> <p>1.0.1.2. The design shall provide for the generation, storage, and retrieval of test data. This requirement is satisfied by the design of the test equipment.</p> <p>1.0.1.3. The design shall provide for the generation, storage, and retrieval of test data. This requirement is satisfied by the design of the test equipment.</p> <p>1.0.1.4. The design shall provide for the generation, storage, and retrieval of test data. This requirement is satisfied by the design of the test equipment.</p> <p>1.0.1.5. The design shall provide for the generation, storage, and retrieval of test data. This requirement is satisfied by the design of the test equipment.</p> <p>1.0.1.6. The design shall provide for the generation, storage, and retrieval of test data. This requirement is satisfied by the design of the test equipment.</p> <p>1.0.1.7. The design shall provide for the generation, storage, and retrieval of test data. This requirement is satisfied by the design of the test equipment.</p> <p>1.0.1.8. The design shall provide for the generation, storage, and retrieval of test data. This requirement is satisfied by the design of the test equipment.</p> <p>1.0.1.9. The design shall provide for the generation, storage, and retrieval of test data. This requirement is satisfied by the design of the test equipment.</p> <p>1.0.1.10. The design shall provide for the generation, storage, and retrieval of test data. This requirement is satisfied by the design of the test equipment.</p>											
1.0.4												
1.0.5												
1.0.6												

Revision _____ Date _____ Approval _____ Document Number _____ Page Number _____

Figure 36 (Continued). BAS for the Function "Integrate and Service SSLS."

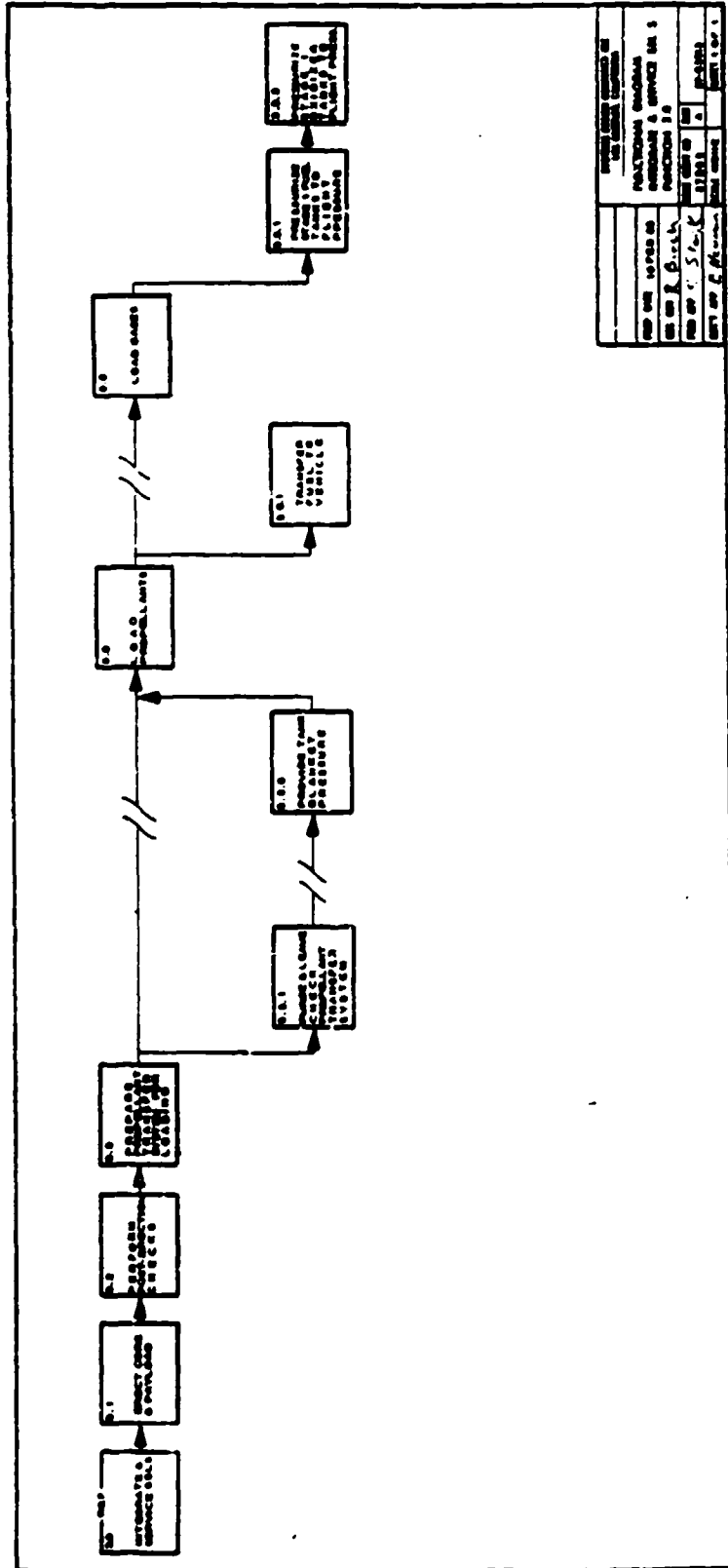

Figure 37. Functional Diagram of Integrals and Service SLS.

Equipment Allocation Sheet	Functional Diagram Title and No.		Equipment Identification (CI or Detail) Spec or Indicator Control Number	PERSONNEL AND TRAINING EQUIPMENT REQUIREMENTS				Procedural Date Requirements	
	Requirements Allocation Sheet	Homeoffice & No. of CB		Design Requirements	Facility Requirements	Personnel Status	Tasks		Time Req
3.1.1 Operator 3.1.2 Supervisor 3.1.3 Maintenance Personnel		3.1.1 Operator 3.1.2 Supervisor 3.1.3 Maintenance Personnel	3.1.1 Operator 3.1.2 Supervisor 3.1.3 Maintenance Personnel	3.1.1 Operator 3.1.2 Supervisor 3.1.3 Maintenance Personnel	3.1.1 Operator 3.1.2 Supervisor 3.1.3 Maintenance Personnel	3.1.1 Operator 3.1.2 Supervisor 3.1.3 Maintenance Personnel	3.1.1 Operator 3.1.2 Supervisor 3.1.3 Maintenance Personnel	3.1.1 Operator 3.1.2 Supervisor 3.1.3 Maintenance Personnel	3.1.1 Operator 3.1.2 Supervisor 3.1.3 Maintenance Personnel
3.1.4 Operator 3.1.5 Supervisor 3.1.6 Maintenance Personnel		3.1.4 Operator 3.1.5 Supervisor 3.1.6 Maintenance Personnel	3.1.4 Operator 3.1.5 Supervisor 3.1.6 Maintenance Personnel	3.1.4 Operator 3.1.5 Supervisor 3.1.6 Maintenance Personnel	3.1.4 Operator 3.1.5 Supervisor 3.1.6 Maintenance Personnel	3.1.4 Operator 3.1.5 Supervisor 3.1.6 Maintenance Personnel	3.1.4 Operator 3.1.5 Supervisor 3.1.6 Maintenance Personnel	3.1.4 Operator 3.1.5 Supervisor 3.1.6 Maintenance Personnel	3.1.4 Operator 3.1.5 Supervisor 3.1.6 Maintenance Personnel

Revision: _____ Date: _____ Approval: _____ Document Number: _____ Page Number: _____

Figure 38. BAS for the Function "Integrate Solid Rocket Motor With Core and Payload."

AFSCM 375-5

10 March 1966

7.0 TRADE STUDY REPORT. Figure 39 is an example of a Trade Study Report on determining a design approach for measuring accurate

quantities of loaded propellants. The actual Trade Study Report would consist of more data than are practical to show in figure 39.

	TITLE Comparison of Methods for Measuring Quantities of Loaded Propellant	TRADE STUDY REPORT NO. <u>173</u> DATE <u>15 Sep 64</u>
<p>1. <u>Scope.</u> This trade study report presents an evaluation of methods for measuring the quantities of loaded propellants and recommends a specific design approach for the AX Space Launch Vehicle.</p> <p>2. <u>Functional and Technical Design Requirements.</u></p> <p>a. The mass of loaded propellants is critical in achieving specified SOR orbital insertion requirements. Accordingly, the propellant loading system must be capable of indicating the quantity of the propellant loaded in each tank to an accuracy of $\pm 0.35\%$ by weight of propellant required. (Reference Volume II, Document 96-5230, dated 2 Aug 64, containing RASs specifying the requirements for the function "Load Propellants"; and trade study AX2340 Vehicle Performance Analysis, dated 25 July 64.)</p> <p>b. The fuel blend consists of: 51.0 \pm 0.5% hydrazine (MIL-P-2653-A); 47.0% minimum UDMH (MIL-P-25604B); and 1.5% maximum of water and other soluble impurities. The nominal density of the fuel blend at 60°F is 50.75 lbs cu ft. A basic deviation in density of the blend of $\pm 0.5\%$ is permitted. The coefficient of thermal expansion at 65°F is .0005753 in/in - °F. (Reference MIL-P-27402 (USAF), 26 April 1960, page 6, para 3.8.)</p> <p>c. Propellant temperatures shall range between 25°F to 65°F. Ambient temperatures will range between 25°F DB and 95°F DB. (Reference Propellant Utilization Study, 23 August 1964, page 137, para 36.)</p> <p>d. Construction materials utilized in the measurement system that will be exposed directly to the propellants shall not be adversely affected by such exposure and shall be compatible with the propellants. (Reference O DOD R&E Handbook, "Handling and Storage of Liquid Propellants," 1 June 1961, page 69, para 3.5.)</p> <p>e. The measurement system shall be required to perform in the range of liquid pressures from 0 to 150 psig.</p> <p>f. The measurement system shall be capable of indicating the quantity of unused propellant removed from each tank after a SCF or Flight Readiness Firing to an accuracy of $\pm 0.35\%$ by weight of propellant removed. If necessary, propellant trapped on board, which cannot be removed by normal PTFS means after firing tests, shall be accounted for by other means of measurement or calculation.</p> <p>3. <u>Design Approaches and Significant Design Characteristics.</u></p> <p>a. Four design approaches were selected for study:</p> <ol style="list-style-type: none"> (1) Digital Weight System (2) Calibrated Storage Vessels (3) Booster Tank High Level Point Sensors (4) Positive Displacement Flowmeter 		
APPROVAL <u>L. Siltanen</u>		PAGE NO. <u>1 of 5</u>

Figure 39. Comparison of Methods for Measuring Quantities of Loaded Propellant

10 March 1966

	TITLE Comparison of Methods for Measuring Quantities of Loaded Propellant	TRADE STUDY REPORT NO. 173 DATE 15 SEP 64
<p>b. Positive Displacement Flowmeter.</p> <p>The following is a partial list of typical characteristics related to a Positive Displacement Flowmeter.</p> <p>(1) The "A" type flowmeter can be calibrated to an accuracy of $\pm 0.05\%$ in a test liquid.</p> <p>(2) The "A" type flowmeter has been soaked in oxidizer liquid and vapor for a period of six weeks to demonstrate compatibility; after inspection and cleaning, the meter was run in water tests during which it functioned satisfactorily. (Ref Test Report 19325.)</p> <p>(3) The flowmeter measurement method and associated equipment are shown schematically in Illustration 1 for the fuel operation only; the schematic for oxidizer is nearly identical.</p> <p>(4) The operation of the flowmeter measurement method and associated equipment is indicated in the schematic diagram shown on Illustration 2.</p> <p>(5) Etc., (In the actual trade study report, additional specific performance capabilities, operability characteristics, maintainability characteristics, etc., would be identified and listed.)</p> <p>c. Calibrated Storage Vessel *</p> <p>d. Digital Weight System *</p> <p>e. Booster Tank High Level Point Sensor *</p> <p>* The significant characteristics of the other three design approaches would be stated in separate paragraphs.</p>		
APPROVAL _____		PAGE NO. 2 of 8

Figure 39 (Continued). Comparison of Methods for Measuring Quantities of Loaded Propellant



TITLE
Comparison of Methods for
Measuring Quantities of Loaded
Propellant

TRADE STUDY
REPORT NO. 173
DATE 15 SEP 64

ILLUSTRATION 1 SCHEMATIC DIAGRAM - FLOWMETER MEASUREMENT METHOD
(FUEL LOADING ONLY SHOWN)

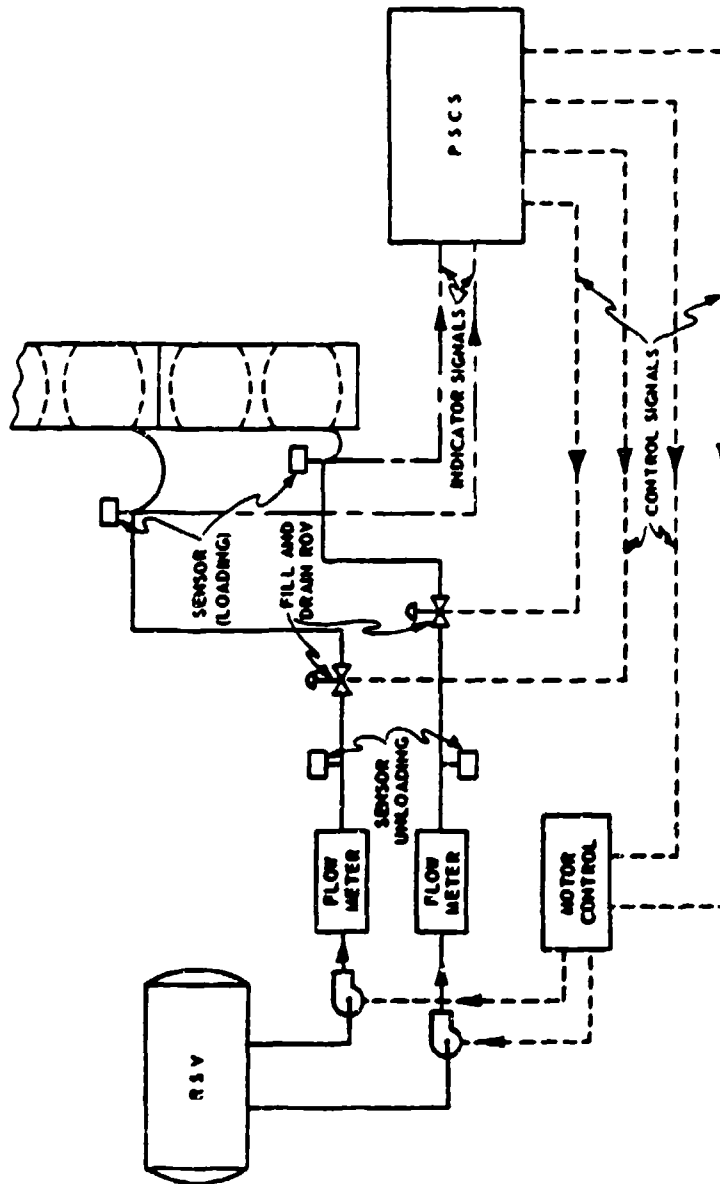

APPROVAL _____

PAGE NO. 3 of 6

Figure 29 (Continued). Comparison of Methods for Measuring Quantities of Loaded Propellant

	TITLE	TRADE STUDY
	Comparison of Methods for Measuring Quantities of Loaded Propellant	REPORT NO. 173
		DATE 15 SEP 64

ILLUSTRATION 2 SCHEMATIC DIAGRAM - FLOWMETER OPERATION



APPROVAL _____

PAGE NO. 4 of 8

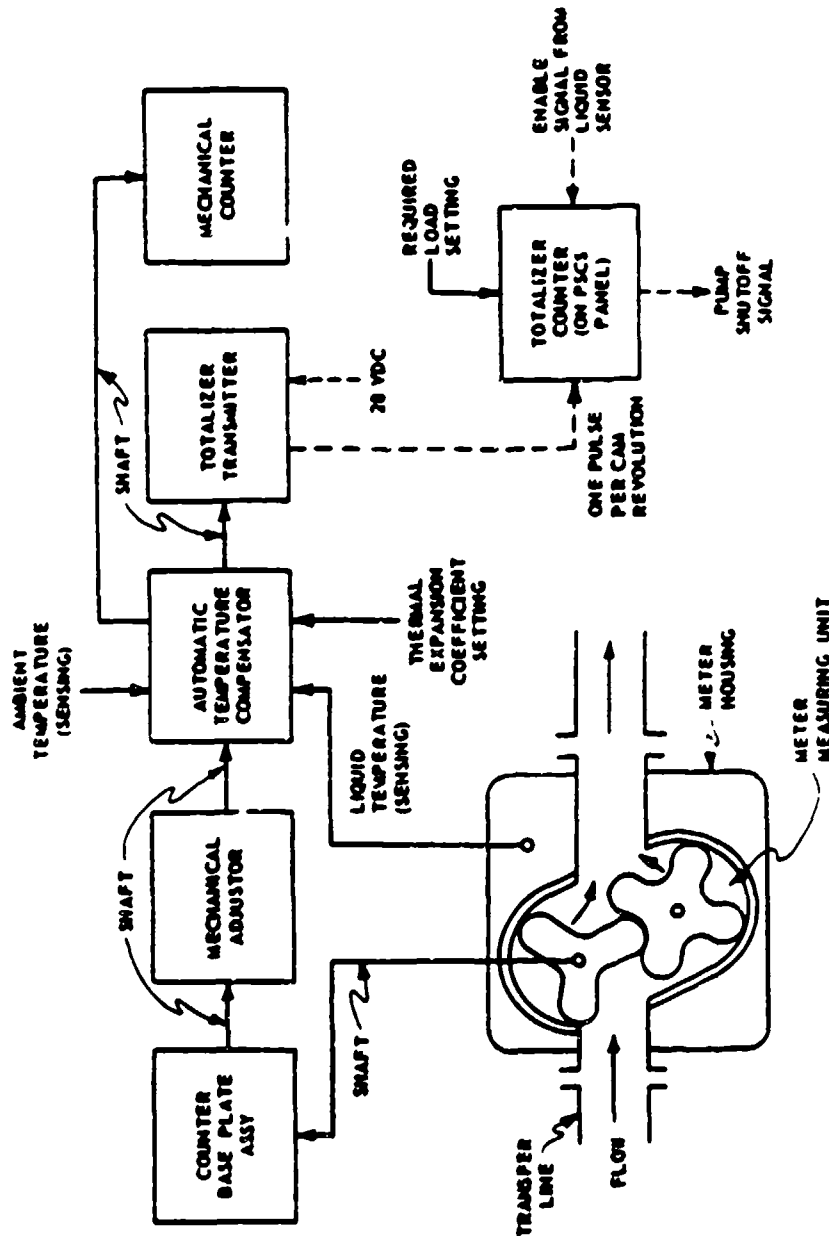
Figure 39 (Continued). Comparison of Methods for Measuring Quantities of Loaded Propellant

	<p>TITLE Comparison of Methods for Measuring Quantities of Loaded Propellant</p>	<p>TRADE STUDY REPORT NO. <u>173</u> DATE <u>15 SEP 64</u></p>	
<p>4. <u>Comparison Matrix of Design Approaches.</u> The digital weight system was rejected as soon as it was verified that the extent of accuracy attainable was $\pm 9.1\%$.</p>			
<p>Functional and Technical Design Requirements</p>	<p>High Booster Tank Level Point Sensors</p>	<p>Calibrated Storage Vessel</p>	<p>Flowmeter</p>
<ol style="list-style-type: none"> 1. Accuracy of $\pm 0.3\%$ by weight. 2. Titan Program Experience 3. Similar Program Experience 4. Applicability to Gemini Launch Vehicle (GLV) Program 5. Reliability MEF=1000 hrs 6. Compatibility with Propellants (See item c of par 3.3) 	<p>$\pm 0.28\%$</p> <p>Used in all Titan II R&D missile launches, in conjunction with calibrated vernier vessel.</p> <p>Unknown for this application.</p> <p>With flowmeter replacing verniers vessels for topping loads, will meet time requirements. Cannot perform unloading measurements when required, except with vernier vessel or flowmeters.</p> <p>Adequate reliability, est 1000 hrs</p> <p>Titan II experience indicates no problems.</p>	<p>$\pm .30\%$</p> <p>Abandoned in favor of point sensor method for Titan II R&D program.</p> <p>None for this application.</p> <p>With vernier vessel, cannot meet time requirements. If flowmeters are used, transfer control becomes more complex and errors of more doubtful magnitude. Cannot perform unloading measurements when required except with vernier vessels and flowmeters.</p> <p>Adequate reliability, est 1000 hrs</p> <p>Titan II experience indicates no problems.</p>	<p>$\pm 0.20\%$</p> <p>Used for Titan I JEM lot missile fuel loadings Operational Titan I system uses for fuel loading also.</p> <p>Thor R&D and tactical programs (no specific data available).</p> <p>Capable of meeting all functional requirements for loading and unloading. Requires shortest PIFS operation time for loading and unloading.</p> <p>Exceeds reliability, est 2000 hrs</p> <p>Meter function after 6-week soaking in oxidiser at W-D. Rock Mountain Arsenal reports no problems with fuel. Tests at Wylie Labs will be used to confirm.</p>

APPROVAL _____

PAGE NO. 5 of 8

Figure 39 (Continued). Comparison of Methods for Measuring Quantities of Loaded Propellant

	<p>TITLE Comparison of Methods for Measuring Quantities of Loaded Propellant</p>	<p>TRADE STUDY REPORT NO. <u>173</u> DATE <u>15 SEP 66</u></p>	
<p>4. <u>Comparison Matrix of Design Approaches.</u> (Cont'd)</p>			
Functional and Technical Design Requirements	High Booster Tank Level Point Sensors	Calibrated Storage Vessel	Flowmeter
<p>7. Procurability for GLV required at AD Aug 19 required at Cape Dec 19</p> <p>8. Maintainability. Minimum pad time required.</p> <p>9. Operability-- Do not require any peculiar or difficult skills.</p> <p>10. Safety (see item d of par 3.3.)</p> <p>11. Cost</p> <p>12. Producibility</p> <p>13. Vulnerability</p> <p>14. Growth Potential</p> <p>15. Etc.</p>	<p>Sensors and vernier vessel can meet schedule. Special build item. 120 day lead time.</p> <p>Maintenance by replacement of sensors. (See flowmeters for further comment.)</p> <p>Requires skilled operators to make computations before loading and in application of correction factors.</p> <p>Safe</p> <p>1.7 million (includes flowmeters required for topping loads and vernier vessels)</p> <p>N/A</p> <p>N/A</p> <p>N/A</p> <p>Etc.</p>	<p>Procurement of RSV with bulkheads and vernier vessel. Special build item requires 240 day lead time. Schedule would be tight.</p> <p>Bulkheads in RSV hamper cleaning efforts. Must be cleaned in place.</p> <p>Same as point sensor method.</p> <p>Hazardous because operators are required in the fuel and oxidizer forms during loading operations.</p> <p>1.5 million</p> <p>N/A</p> <p>N/A</p> <p>N/A</p> <p>Etc.</p>	<p>Flowmeters available "off-the-shelf" 60 day lead time.</p> <p>Periodic cleaning and recalibration of meters, can be removed for maintenance spare meters required. To protect warranty, manufacture must do meter disassembly and reassembly for cleaning.</p> <p>Same as point sensor method. However, this method, depends least on operator skill than other methods due to automatic weight determination capability.</p> <p>Safe</p> <p>1.062 million See Table I</p> <p>N/A</p> <p>N/A</p> <p>N/A</p> <p>Etc.</p>

APPROVAL _____

PAGE NO. 6 of 8

Figure 39 (Continued). Comparison of Methods for Measuring Quantities of Loaded Propellant

	TITLE Comparison of Methods for Measuring Quantities of Loaded Propellant	TRADE STUDY REPORT NO. <u>173</u> DATE <u>15 SEP 64</u>
<p>5. <u>Recommended Design Approach.</u></p> <p>The positive displacement flowmeter is recommended for the following reasons:</p> <ul style="list-style-type: none"> a. A flowmeter accuracy of 0.2% is attainable and meets the requirements of the overall measurement system. (Best accuracy of those examined.) b. Maintenance including calibration of the flowmeters is readily accomplished on a remove and replace basis to minimize pad time. c. It meets all functional requirements including time constraints, in terms of establishing the load in individual LV tanks in the shortest PTPS operation time (dual loading technique). d. Measurements of propellants removed from individual tanks after SCF and FRF can be readily accomplished without additional equipment. e. The method depends least of those examined on the skill of the operator. f. The components associated with the system are "off-the-shelf" and readily available. g. It is easily adapted to supporting the point sensor method if experience indicates the need for an alternative. h. Illustration 3 is a mechanization diagram showing the positive displacement flowmeter within the fuel distribution unit. 		
APPROVAL _____	PAGE NO. <u>7 of 8</u>	

Figure 39 (Continued). Comparison of Methods for Measuring Quantities of Loaded Propellant



TITLE
 Comparison of Methods for
 Measuring Quantities of Loaded
 Propellants

TRADE STUDY
 REPORT NO. 173
 DATE 15 SEP 64

ILLUSTRATION 3 MECHANIZATION DIAGRAM OF THE PROPELLANT
 TRANSFER & PRESSURIZATION

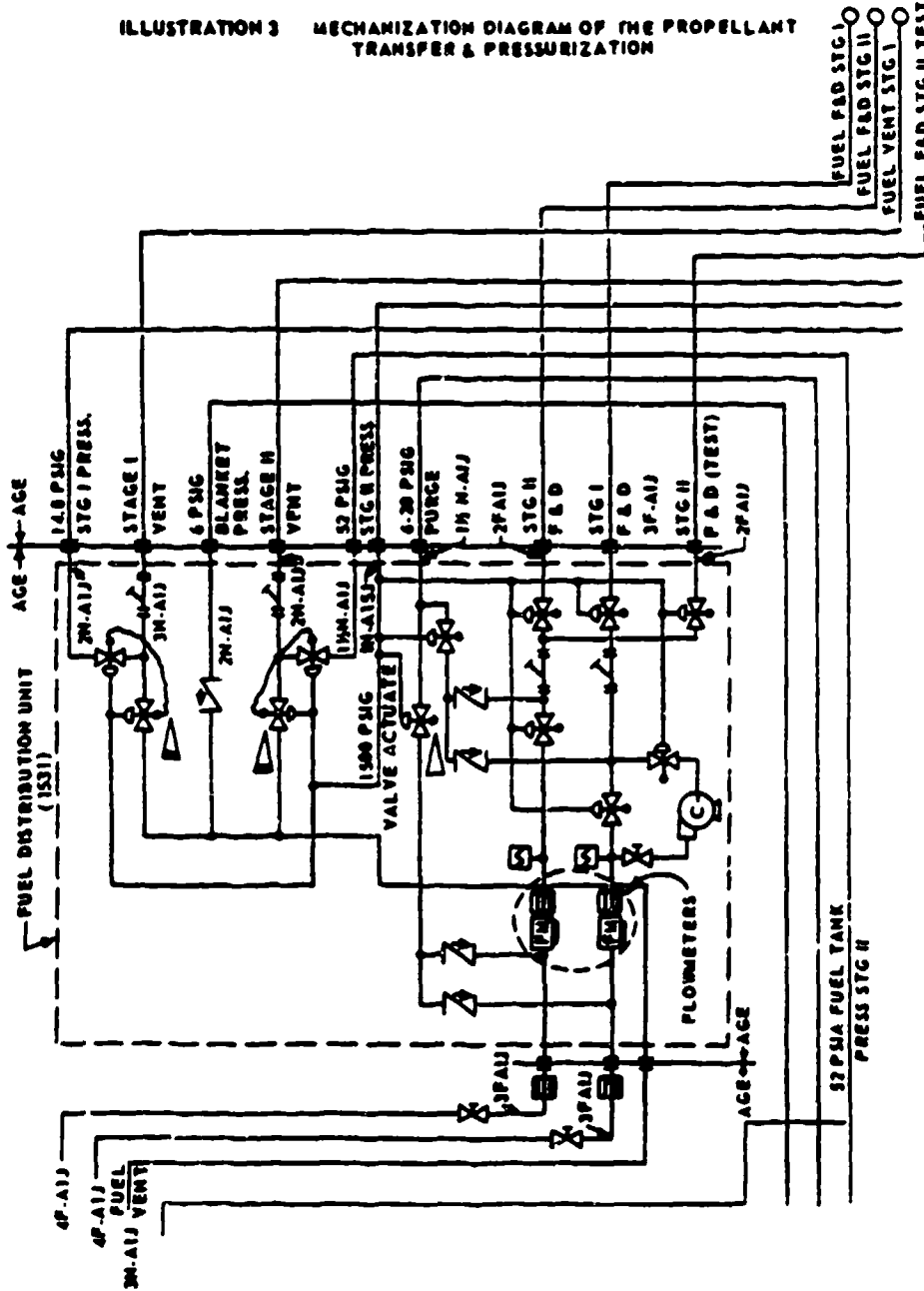

APPROVAL _____

PAGE NO. 6 of 8

Figure 39 (Continued). Comparison of Methods for Measuring Quantities of Loaded Propellant

10 March 1966

AFSCM 375-5

8.0 SCHEMATIC BLOCK DIAGRAMS:

8.1 Figure 40. Figure 40 is an example of a schematic diagram portraying the functions involved in a communications subsystem.

8.2 Figures 41, 42, and 43. Figures 41, 42, and 43 show an example of a family of related schematic diagrams pertaining to a standardized launch-control system 9XX developed as

an entity to interface with an existing launch vehicle, spacecraft, and facility. The figures portray three levels of detail of schematic diagrams.

8.3 Figures 44 and 45. Figures 44 and 45 are examples of schematic diagrams for a propellant transfer and pressurization subsystem. These diagrams relate to the trade study example provided in paragraph 7.0.

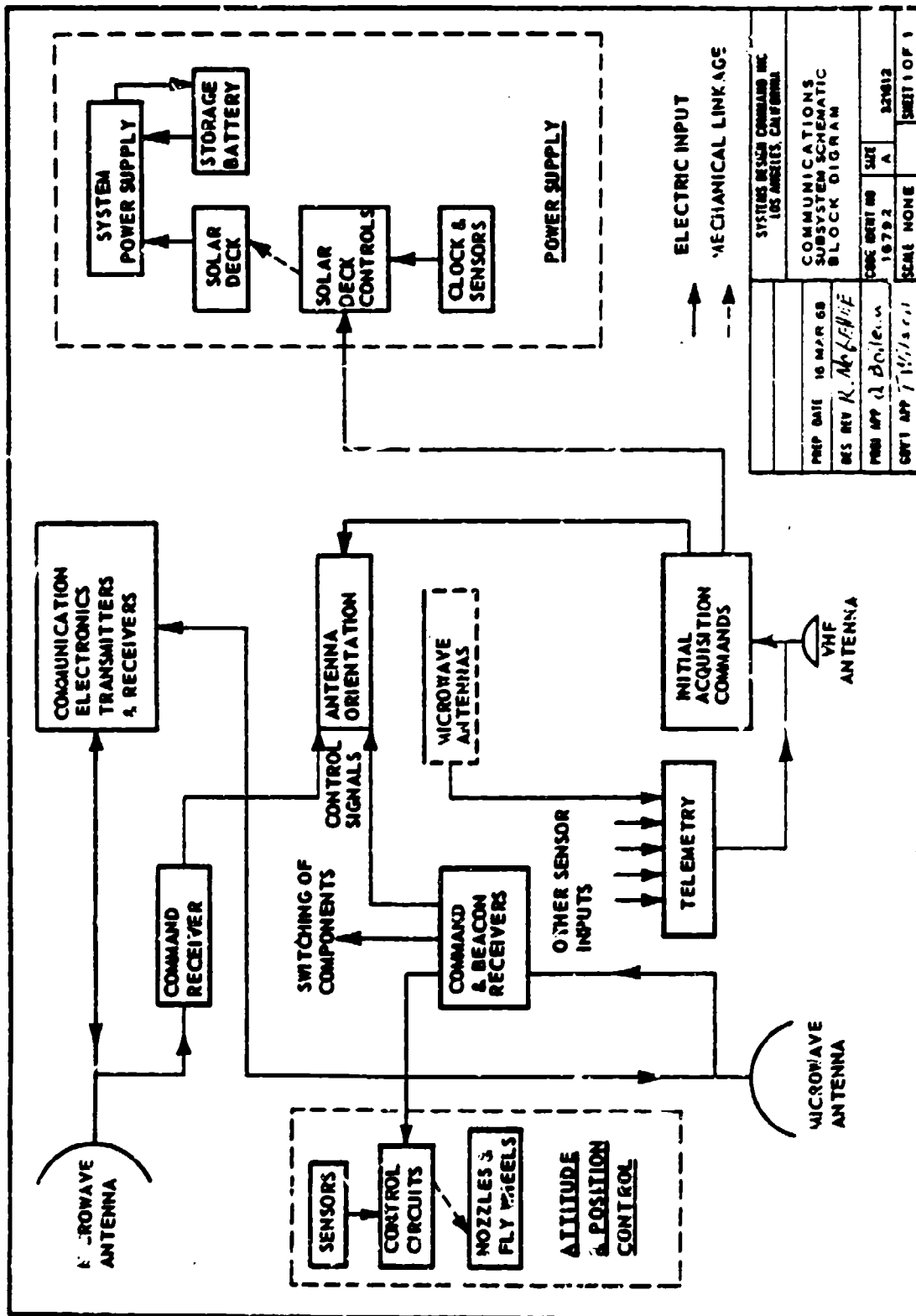

SYSTEMS DESIGN COMPANY INC LOS ANGELES, CALIFORNIA	
PREP DATE 16 MAR 68	COMMUNICATIONS SUBSYSTEM SCHEMATIC BLOCK DIAGRAM
DESIGNER R. M. [Signature]	SIZE A
PROJ APP 2 [Signature]	CDC DWT NO 16782
CRT APP 7 [Signature]	SCHEM NAME SHEET 1 OF 1

Figure 10. Schematic Diagram of Communication Subsystem.

10 March 1966

AFSCM 375-5

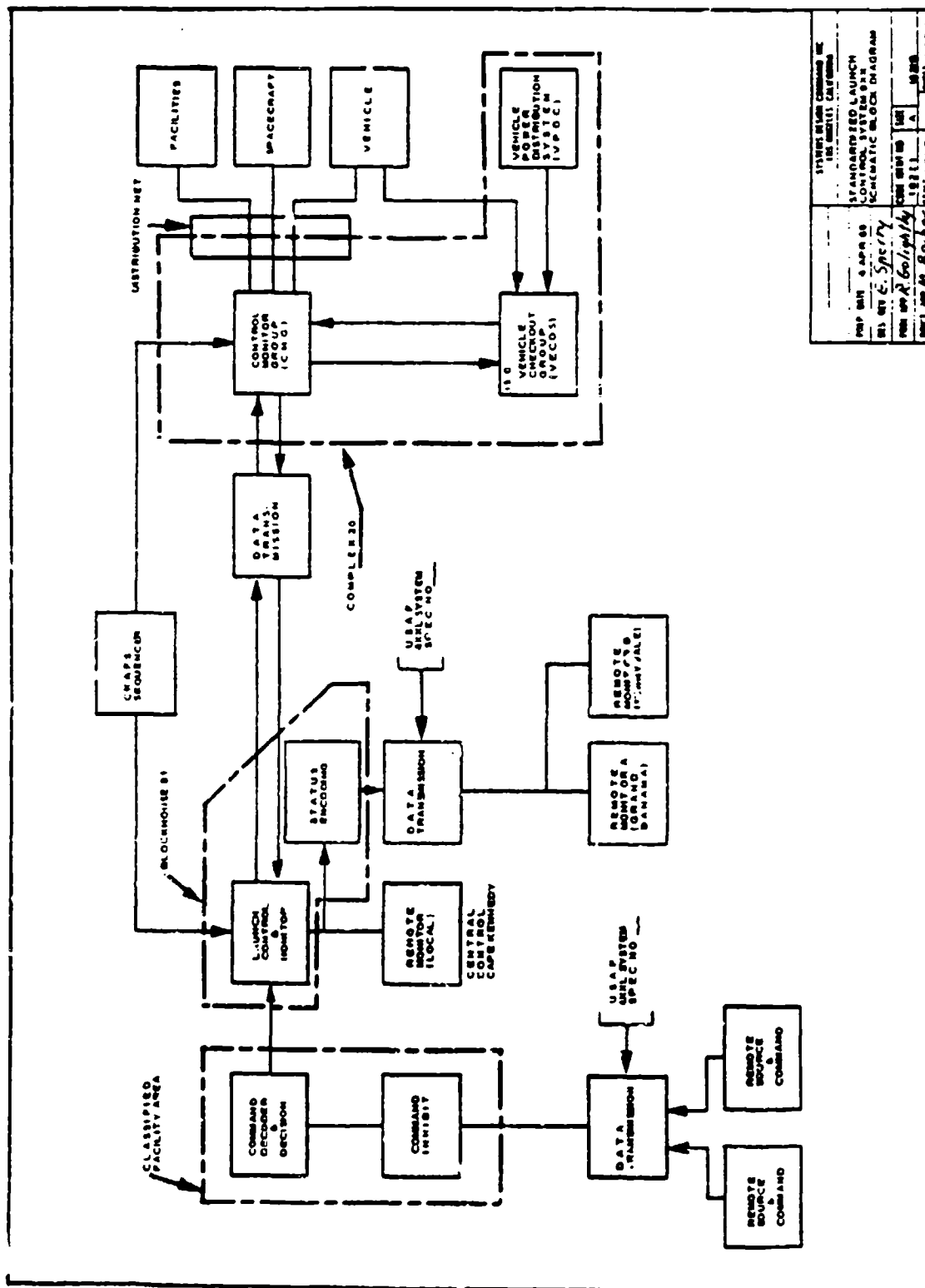

Figure 41. Schematic Diagram (First Level) Standardized Launch Control System.

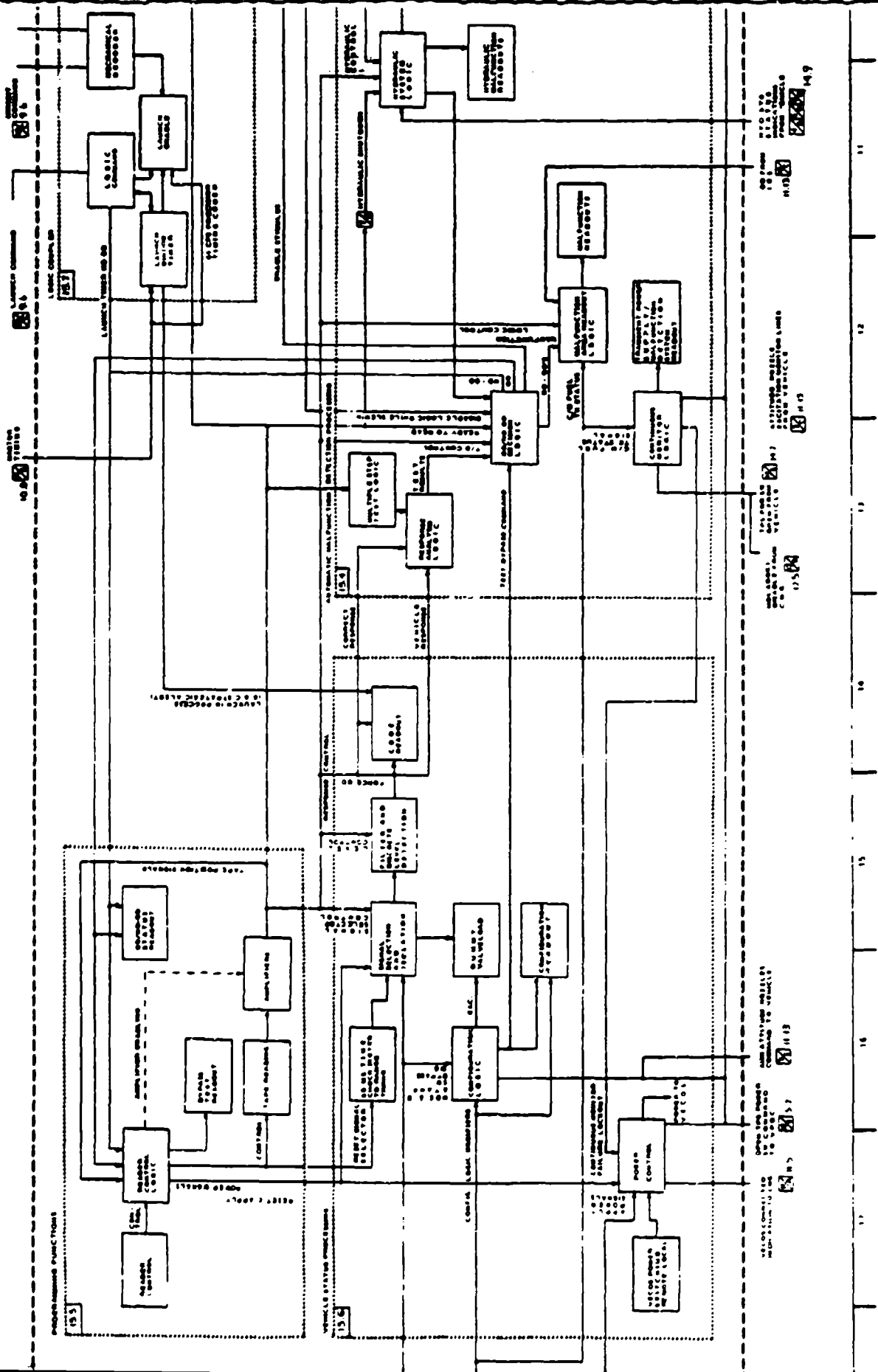

Figure 42 Schematic Diagram (Second Level) of Vehicle Check-out Group

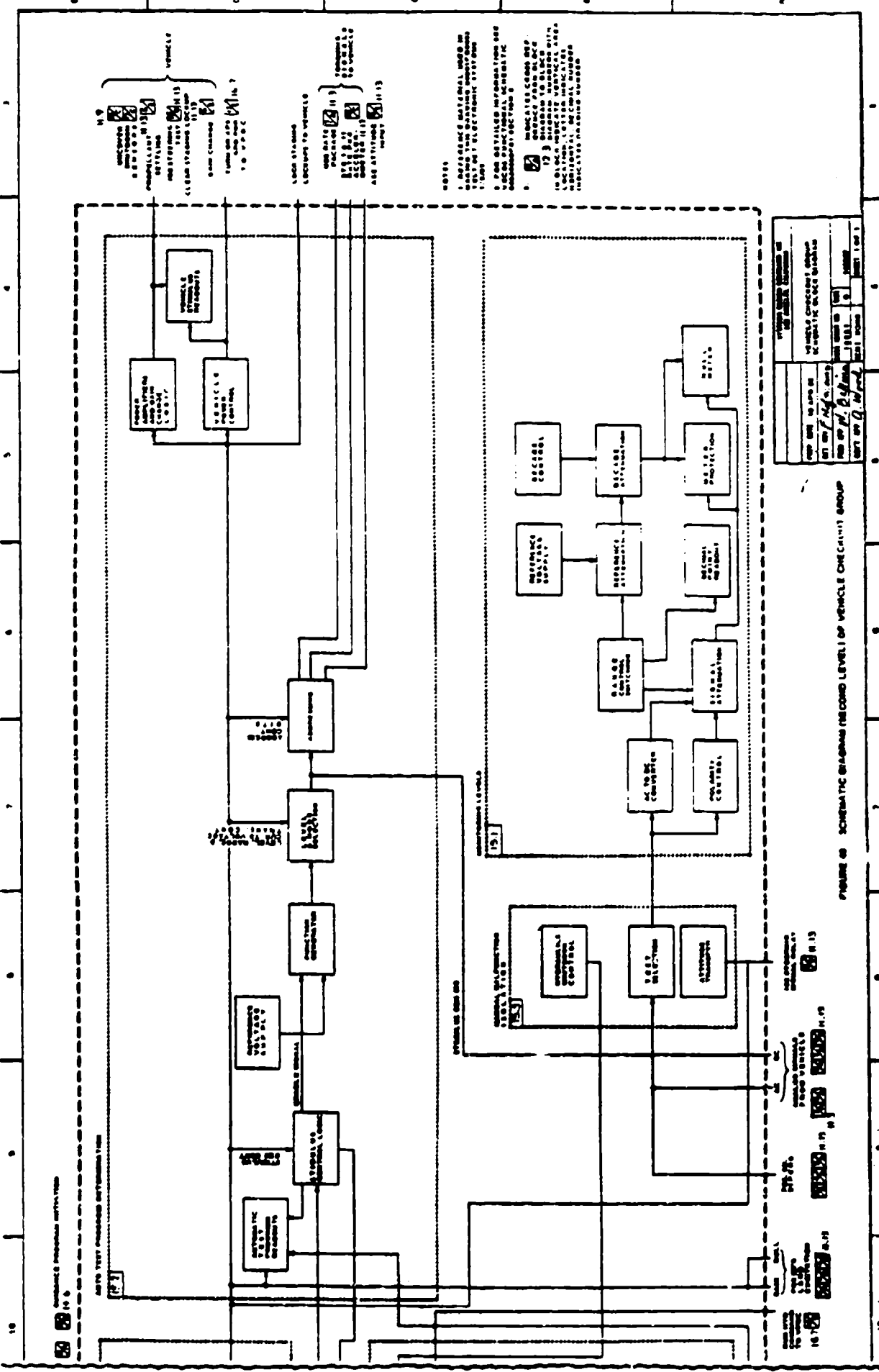

FIGURE 48 SCHEMATIC DIAGRAM (RECORD LEVEL) OF VEHICLE CHECKOUT GROUP

Figure 48 Continued. Schematic Diagram (Record Level) of Vehicle Checkout Group.

10 March 1946

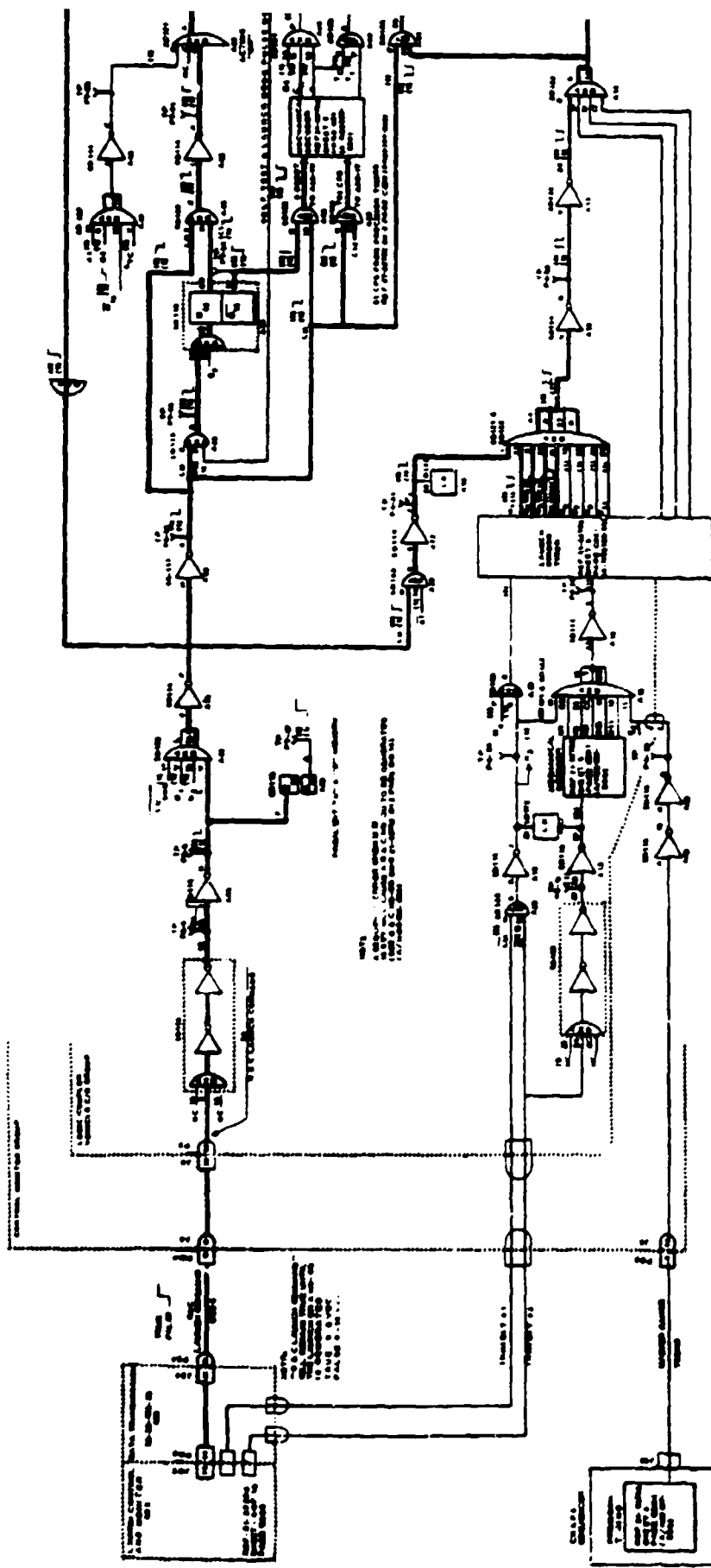
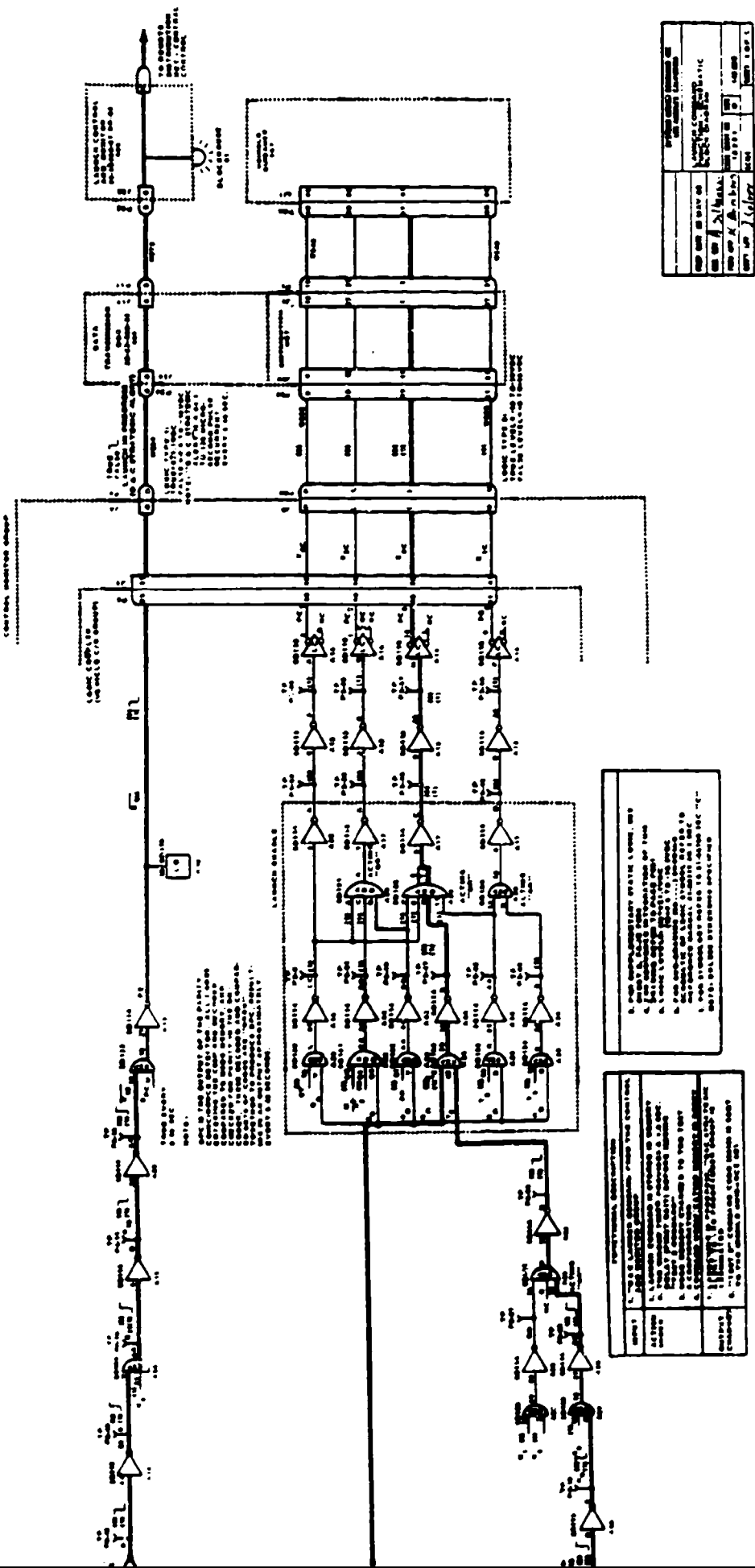

Figure 43. Schematic Diagram (Third Level of Command Function)



OPERATIONAL CHECKS:

- 1. THE CIRCUITRY FROM THE LEFT TO THE RIGHT IS:
- 2. THE CIRCUITRY FROM THE LEFT TO THE RIGHT IS:
- 3. THE CIRCUITRY FROM THE LEFT TO THE RIGHT IS:
- 4. THE CIRCUITRY FROM THE LEFT TO THE RIGHT IS:
- 5. THE CIRCUITRY FROM THE LEFT TO THE RIGHT IS:
- 6. THE CIRCUITRY FROM THE LEFT TO THE RIGHT IS:
- 7. THE CIRCUITRY FROM THE LEFT TO THE RIGHT IS:
- 8. THE CIRCUITRY FROM THE LEFT TO THE RIGHT IS:

OPERATIONAL CHECKS:

- 1. THE CIRCUITRY FROM THE LEFT TO THE RIGHT IS:
- 2. THE CIRCUITRY FROM THE LEFT TO THE RIGHT IS:
- 3. THE CIRCUITRY FROM THE LEFT TO THE RIGHT IS:
- 4. THE CIRCUITRY FROM THE LEFT TO THE RIGHT IS:
- 5. THE CIRCUITRY FROM THE LEFT TO THE RIGHT IS:
- 6. THE CIRCUITRY FROM THE LEFT TO THE RIGHT IS:
- 7. THE CIRCUITRY FROM THE LEFT TO THE RIGHT IS:
- 8. THE CIRCUITRY FROM THE LEFT TO THE RIGHT IS:

Figure 43 (Continued) Schematic Diagram (Third Level) of Length Command Function

10 March 1966

AFSCM 375-3)

9.0 TIME LINE SHEET. Figure 46 provides an example of a time line for the time critical function, "Launch countdown."

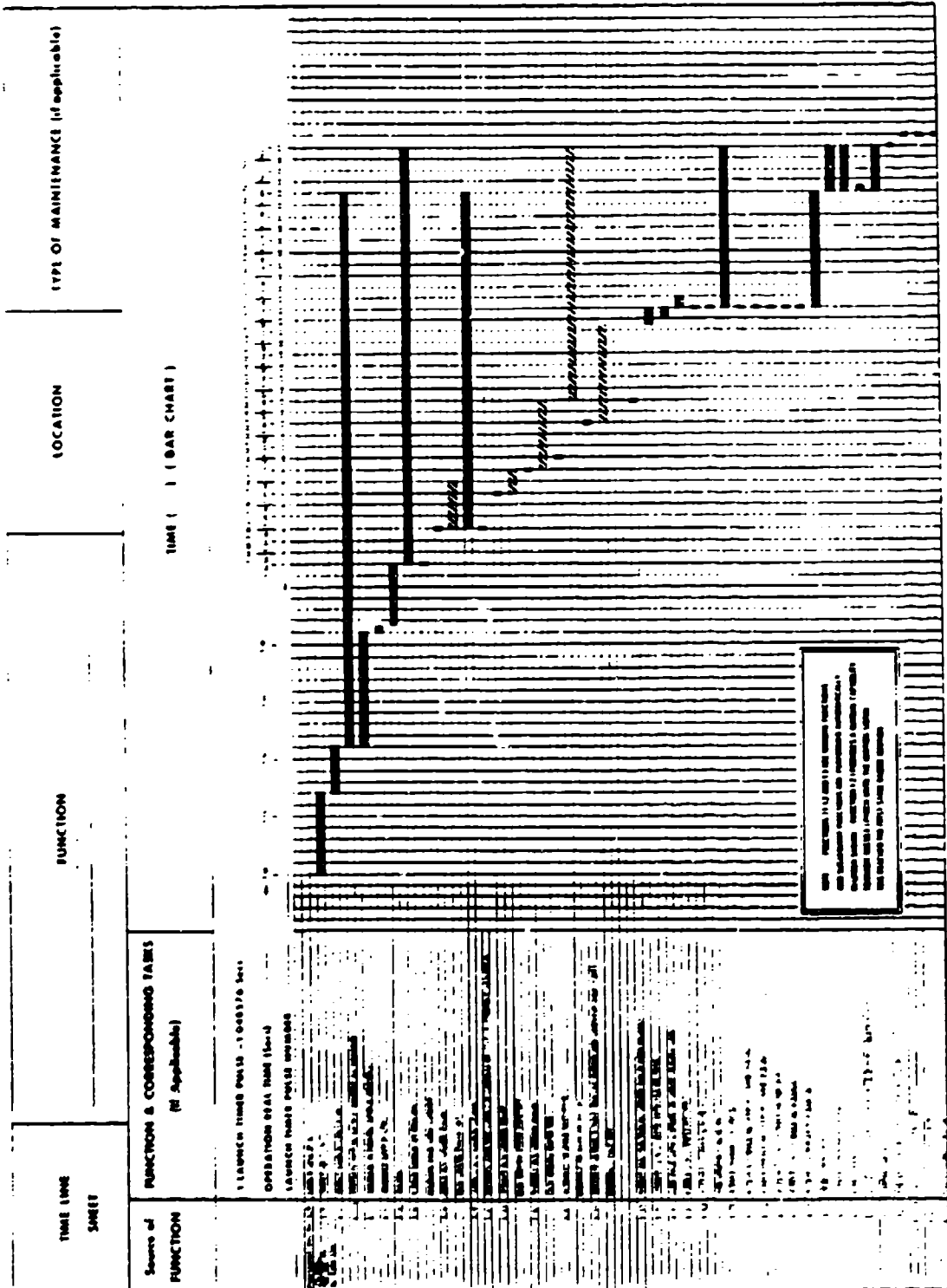

Revision _____ Date _____ Approved _____ Document No. _____ Page No. _____

Figure 46. Time Line of Launch Countdown.

10 March 1966

AFSCM 375-5)

10.0 DESIGN SHEET. Figure 47 is an example
of a design sheet for a communications control

panel CEI.

DESIGN SHEET	NOMENCLATURE COMMUNICATIONS CONTROL PANEL (CCP)	CEI NO OR CRITICAL COMPONENT CODE IDENTIFICATION <u>345E78A</u> DETAIL SPEC NO. _____
REQUIREMENTS FOR DESIGN AND TEST		
<p>3. Requirements Performance, design, and construction requirements specified herein are applicable to the Communications Control Panel (CCP). The CCP is a part of the Ground Electronic Subsystem (GES).</p> <p>3.1. Performance</p> <p>3.1.1 Functional Characteristics The CCP shall provide the capability for selecting among designated communications paths both receipt and initiation of voice communications, and shall also provide the capability for signaling, monitoring, and displaying status of the various communications links and channels.</p> <p>3.1.1.1 Primary Performance Characteristics</p> <p>FUNCTION 2.6.11 a) A selection capability shall permit connection of the handset or headset to the following voice communication paths:</p> <ol style="list-style-type: none"> (1) Launch facilities (LF) (2) Dial lines 1 and 2 (TELCOM 1 & 2) (3) Hardened Voice Channel (HVC) (4) Emergency War Order I (EWO I) (5) Emergency War Order II (EWO II) (6) Security Control Center (SCC) (7) Instrument Control Center (ICC) (8) High Frequency Radio Link (HF) (9) Ultra High Frequency Radio Link (UHF) (10) Very High Frequency Radio Link (VHF) (11) Inter-Phone Communications (IPC) <p>FUNCTION 2.39.3 b) An audio monitoring capability shall be incorporated for the TELCOM, HF, UHF, and VHF links.</p> <p>FUNCTION 2.39.4 c) Signaling capability shall be provided for selectively alerting other facilities to incoming communications.</p> <p>FUNCTION 2.39.6 d) Visual indication of individual voice path traffic status shall be provided.</p> <p>FUNCTION 2.39.7 e) A common audible alarm shall be provided to alert the CCP operator to incoming communications from any of the communications links identified in 3.1.1.1 a., excepting for the LF-IPC (3.1.1.1 a.11).</p> <p>FUNCTION 2.44.10 f) Provision shall be made to permit connecting a single telephone dial to either of the two dial lines (TELCOM 1 & 2).</p> <p>FUNCTION 2.45.2 g) Individual visual indicators shall be provided to indicate receipt of a Primary Alert System (PAS) message from either the Strategic Air Command (SAC) or the Numbered Air Force Headquarters (NAFH) circuits.</p> <p>FUNCTION 2.45.3 h) Two separate and distinct audible alarm tones shall be provided to indicate status of the Message Processing Control System (MPCS).</p> <p>FUNCTION 2.45.4 i) A pre-emptive audio monitoring capability shall be provided for the 279L messages over all other audible signals at the CCP.</p> <p>j) The CCP shall meet the applicable requirements of the Cable Subsystem Transmission criteria document MPO-SR-11-5-400, and of Weapon Effects criteria document GM 75269.</p> <p>3.1.1.2 Secondary Performance Characteristics</p> <p>FUNCTION 2.6.11 a) The CCP shall be equipped with controls for initiating the function of switching the handset or headset from one talking path to another.</p>		

REVISION B APPROVAL T. BLACK DATE 4 JUN 1965 PAGE NO. 1 OF 13

Figure 47. Design Sheet for Communications Control Panel.

10 March 1966

AFSCM 375-5

DESIGN SHEET	NOMENCLATURE COMMUNICATIONS CONTROL PANEL (CCP)	CEI NO. OR CRITICAL COMPONENT CODE IDENTIFICATION <u>345678A</u> DETAIL SPEC NO. _____
--------------	--	---

REQUIREMENTS FOR DESIGN AND TEST

FUNCTION
2.39.3

- b) The controls shall consist of three banks of locking pushbutton switches.
 - c) Each bank of switches shall be equipped with a single clear button which shall release any locked switch to its normal position.
 - d) Only one switch in each bank shall have locking capability at any one time; depressing a second switch in the same bank shall automatically unlock the first switch and allow the second switch to lock.
 - e) Switch Bank One (SB-1) shall contain ten switches. Each of these ten switches shall control the voice path to an individual and separate LF.
 - f) Switch Bank Two (SB-2) shall contain eight switches which connect the voice paths for HF, UHF, VHF, EWO I, EWO II, EVC, SCC, and ICC. One switch only shall connect to one voice path.
 - g) Switch Bank Three (SB-3) shall contain two switches: one switch for TELCOM 1 and TELCOM 2; and one switch for connecting the IPC with the LF.
 - h) Controls for audibly monitoring TELCOM, HF, UHF, and VHF shall consist of four alternate action pushbutton switches, a panel mounted speaker, and a volume control to adjust the speaker sound level. The TELCOM switch shall connect the speaker to any desired voice path other than the HF, UHF, or VHF channels. Each of the radio channels shall be connected to the speaker by depressing a corresponding switch. Only one switch shall be capable of being locked in at any one time.
- 3.1.2 Operability
- 3.1.2.1 Reliability
The reliability factor for the CCP shall not be less than .9979 at a confidence level of 95%.
 - 3.1.2.2 Maintenance
 - 3.1.2.2.1 Maintainability
 - a) Mean time to repair (MTTR) any failed component of the CCP designated for organizational maintenance shall not exceed 20 man-minutes.
 - b) Mean time to repair (MTTR) any failed component of the CCP designated for field maintenance shall not exceed 8 man-hours.
 - c) Fault isolation necessary to isolate malfunctions to gross areas (e.g., equipment rack, console) shall be provided. A capability shall be provided to isolate malfunctions to the drawer or equivalent levels with the CCP in the installed configuration.
 - d) Fault isolation shall be accomplished by maintenance procedures and/or MGE.
 - 3.1.2.2.2 Maintenance Repair Cycle
 - a) Scheduled organizational maintenance shall be required after no less than each 2000 operating hours.
 - b) The scheduled maintenance shall be accomplished in no more than 35 real-time minutes.
 - 3.1.2.2.3 Service and Access
 - a) Indicator lamps and control knobs shall be replaceable from the panel front.
 - b) The CCP shall be removable as a complete unit from the console.
 - c) Provisions shall be made to minimize the effort required to disengage the CCP plug-in connectors from the console mounted receptacles.
 - d) A positive plug-receptacle alignment provision shall be incorporated in the CCP to prohibit incurring plug-receptacle damage during CCP removal or installation.

REVISION B APPROVAL _____ DATE 4 JUN 1965 PAGE NO. 2 OF 13

Figure 47 (Continued). Design Sheet for Communications Control Panel.

DESIGN SHEET	NOMENCLATURE COMMUNICATIONS CONTROL PANEL (CCP)	CEI NO. OR CRITICAL COMPONENT CODE IDENTIFICATION <u>345678A</u> DETAIL SPEC NO. _____
REQUIREMENTS FOR DESIGN AND TEST		
<p>3.1.2.3 Useful Life - Not applicable.</p> <p>3.1.2.4 Environmental</p> <p>3.1.2.4.1 Non-Operating Conditions</p> <ol style="list-style-type: none"> a) Ambient temperature: no cooling required. b) Storage temperature range: -65°F to -150°F; duration not to exceed 15 days. c) Humidity range: 0 to 100% RH. d) Altitude: Sea level to 50,000 ft.; duration not to exceed 50 hours at altitudes in excess of 7000 feet. e) Vibration = (1) 3.5G RMS from 5 to 50 cps, double amplitude limit 0.4 inch. (2) 1.5G RMS from 50 to 300 cps. (3) vibration can occur in any axis. <p>3.1.2.4.2 Operating Conditions</p> <ol style="list-style-type: none"> a) Humidity Range: 45% to 60% RH. b) Altitude: Sea level to 7000 ft. c) Shock: Reference-Criteria Document GM75269. 200G peak at equipment attach points in each of the 6 directions. d) Vibration: (1) 3G RMS from 2 to 8 cps, double amplitude limit less than 6 inches. (2) 2G RMS from 8 to 2000 cps. (3) vibration can occur in any axis. <p>3.1.2.5 Transportability</p> <ol style="list-style-type: none"> a) The CCP shall be designed to withstand shipping and handling shocks of 100G peak acceleration. b) The CCP shall be transportable by aircraft and motor vehicles. c) The CCP shall be packaged in such a way as to preclude the possibility of damage to the panel or components. d) Before being placed in its shipping container, the CCP shall be totally enclosed by a suitable film material sealed to prevent entry of dust, dirt, or other atmosphere-borne contaminants. e) Packaging shall be in accordance with appropriate methods extracted from MIL-P-7936. <p>3.1.2.6 Human Performance</p> <ol style="list-style-type: none"> a) Design of the CCP including controls and displays shall comply with human engineering criteria on console and panel layout specified in MIL-STD-803A-1. b) Controls shall be grouped by function to minimize operating effort and complexity. c) The basic colors for indicators and switches shall be black and white. d) Positive lock and interlock controls shall be incorporated throughout. <p>3.1.2.7 Safety</p> <p>3.1.2.7.1 Personnel Safety</p> <ol style="list-style-type: none"> a) CCP grounding shall be accomplished to conform with drawing number 00-251437. b) RF gaskets shall be employed to shield against electrostatic fields. <p>3.1.2.7.2, Equipment Safety - Not applicable.</p> <p>3.1.2.8 Noise and Vibration</p> <p>Components shall not be employed in the CCP which simulate the sounds produced by the audible signaling devices.</p>		

REVISION B APPROVAL _____ DATE 4 JUN 1965 PAGE NO. 3 OF 13

Figure 47 (Continued). Design Sheet for Communications Control Panel.

10 March 1966

AFSCM 375-5

DESIGN SHEET	NOMENCLATURE COMMUNICATIONS CONTROL PANEL (CCP)	CEI NO. OR CRITICAL COMPONENT CODE IDENTIFICATION <u>345678A</u> DETAIL SPEC NO. _____
REQUIREMENTS FOR DESIGN AND TEST		
<p>3.2 CEI Definition</p> <p>3.2.1 Interface Requirements</p> <p>The CCP shall interface with the following:</p> <ul style="list-style-type: none"> a) Communications Control Console Ref: CEI Number 141506A b) Intra Site Cabling Ref: CEI Numbers 140067A, 140068A, 140069A c) Voice Terminal Equipment Ref: CEI Number 146452A d) SAC Cable Transmission Equipment (CTE) and Monitor Rack Ref: CEI Number 140112A e) Handset Ref: CEI Number 140372A f) Headset Ref: CEI Number 140352A <p>3.2.1.1 Schematic Arrangement</p> <ul style="list-style-type: none"> a) Physical CCP layout Ref: Drawing number 00-251437 b) Voice Switch and Control Interface Diagram Ref: Drawing number 00-25-251583 <p>3.2.1.2 Detailed Interface Definition</p> <ul style="list-style-type: none"> a) Power, Electrical See: Table I, "Power Furnished," Appendix 10-3(a). b) Signal Interfaces See: Table II, "Signal Interfaces," Appendix 10-3(b). <p>3.2.2 Component Identification</p> <ul style="list-style-type: none"> 3.2.2.1 Government-Furnished Property List - Not applicable. 3.2.2.2 Engineering Critical Components List - Not applicable. 3.2.2.3 Logistics Critical Components List - Not applicable. <p>3.3 Design and Construction</p> <p>3.3.1 General Design Features</p> <ul style="list-style-type: none"> a) The dimensions of the CCP are shown on drawing numbers 01-253027, "Panel, Communications Control." The CCP shall be completely removable from the console by loosening holding screws on the face of the panel and then jacking the panel out of the console. b) Connecting circuits from the panel to the console shall be made by plug-in type connectors mounted on the rear of the panel. Handles shall be provided for lifting the panel out of the console. <p>FUNCTION 2.6.11 c) Three banks of switches shall be grouped according to function and further integrated on the panel to minimize effort and complexity during system operation. All switches shall be notably mounted on the front of the panel. Each bank of switches shall contain a single clear button. Only one switch shall be capable of being locked in at any one time.</p> <p>FUNCTION 2.39.3 d) A telephone dial, telephone handset, FM speaker, and volume controls for the speaker and handset/headset to adjust sound levels shall be mounted on the front of the panel.</p> <p>3.3.2 Selection of Specifications and Standards</p> <ul style="list-style-type: none"> a) MIL-STD-143 shall be the basis for determining usage of specifications and standards. 		

REVISION B APPROVAL _____ DATE 4 Jun 1965 PAGE NO. 4 OF 13

Figure 47 (Continued). Design Sheet for Communications Control Panel.

DESIGN SHEET	NOMENCLATURE COMMUNICATIONS CONTROL PANEL (CCP)	CEI NO OR CRITICAL COMPONENT CODE IDENTIFICATION 345678A DETAIL SPEC NO. _____
--------------	--	---

REQUIREMENTS FOR DESIGN AND TEST

- b) All standards or specifications, other than those established and approved for use by the Air Force, must be approved by the procuring agency prior to incorporation.
- 3.3.3 Materials, Parts, and Processes
Structural design of the CCP shall incorporate materials, fabrication, assembly, and test requirements in compliance with paragraph 3.2.1.2 of the System Specification. Materials shall be selected according to ASES List 100. Comply with requirements of MIL-E-4150.
- 3.3.4 Standard and Commercial Parts.
Parts shall be selected according to the following priorities:
a) P1: Reliability Improvement Plan (RIP) approved parts.
b) P2: RIP parts in the approval cycle.
c) P3: MIL-STD Parts.
- 3.3.5 Moisture and Fungus Resistance
3.3.5.1 Fungus Resistance
The CCP shall utilize non-nutrient materials throughout.
- 3.3.5.2 Moisture Resistance
a) The CCP shall be protected by a packaging technique to prevent condensation during shipment and storage.
b) The CCP shall be installed in a protected, climatic environment during operation.
- 3.3.6 Corrosion of Metal Parts
Use of dissimilar metals in direct contact shall be avoided unless such metals are electrolytically compatible. Finish shall conform with requirements of MIL-STD-808.
- 3.3.7 Interchangeability and Replaceability
The CCP shall be directly interchangeable mechanically and electrically with any other CCP.
- 3.3.8 Workmanship
The CCP shall meet finish requirements of paragraph 3.2.1.6 of the System Specification, and shall otherwise be constructed and finished in accordance with best commercial practice.
- 3.3.9 Electromagnetic Interference
a) Shielding shall be employed on an individual basis at the rack level. Shielded cable/wire shall be used for all signal paths.
b) Twisted pairs shall be employed where possible for all circuits to minimize wire to wire surge voltage effects.
c) Lines shall be equipped with isolation transformers to eliminate induced longitudinal surges.
d) Voltage limiters shall be installed across windings on the equipment side of transformers.
- 3.3.10 Identification and Markings
Identification and marking shall comply with MIL-STD-130. Identification plates shall conform to MS24123. Comply with requirements of MIL-T-704 when paint marking.
- 3.3.11 Storage
Reference paragraph 3.1.2.4.1.

REVISION B APPROVAL _____ DATE 4 Jun 1965 PAGE NO. 5 OF 13

Figure 47 (Continued). Design Sheet for Communications Control Panel.

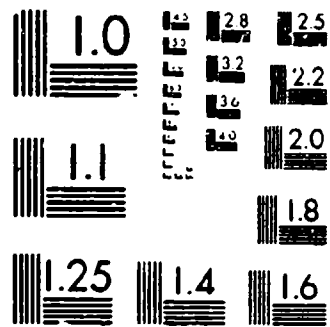

MICROCOPY RESOLUTION TEST CHART
NATIONAL BUREAU OF STANDARDS-1963-A

10 March 1966

AFSCM 375-5

DESIGN SHEET	NOMENCLATURE COMMUNICATIONS CONTROL PANEL (CCP)	CEI NO. OR CRITICAL COMPONENT CODE IDENTIFICATION <u>1-5678A</u> DETAIL SPEC NO. _____																																																																																																																																																																																		
REQUIREMENTS FOR DESIGN AND TEST																																																																																																																																																																																				
<p>APPENDIX 10-3 (a)</p> <p>TABLE I POWER FURNISHED</p> <table style="width: 100%; border-collapse: collapse;"> <thead> <tr> <th style="text-align: left;">SOURCE</th> <th style="text-align: left;">VOLTAGE</th> <th style="text-align: left;">TOLERANCE</th> <th style="text-align: left;">FREQUENCY</th> <th style="text-align: left;">TOLERANCE</th> <th style="text-align: left;">POWER</th> <th style="text-align: left;">PHASE</th> <th style="text-align: left;">WIRES</th> </tr> </thead> <tbody> <tr> <td>6207</td> <td>-24V</td> <td>±1%</td> <td>DC</td> <td>N.A.</td> <td>40W</td> <td>N.A.</td> <td>N.A.</td> </tr> </tbody> </table> <p>APPENDIX 10-3 (b)</p> <p>TABLE II SIGNAL INTERFACES</p> <table style="width: 100%; border-collapse: collapse;"> <thead> <tr> <th style="text-align: left;"><u>SIGNAL NAMES</u></th> <th style="text-align: left;"><u>SIGNAL FREQUENCY</u></th> <th style="text-align: left;"><u>DB LEVEL</u></th> <th style="text-align: left;"><u>VOLT LEVEL</u></th> <th style="text-align: left;"><u>INTERFACE W/ CEI NO.</u></th> <th style="text-align: left;"><u>NO. OF LINES</u></th> </tr> </thead> <tbody> <tr> <td>Visual Monitor Facility-I</td> <td>3-5 cps</td> <td>N.A.</td> <td>0 to -24VDC</td> <td>140067A 140068A 140069A</td> <td>1</td> </tr> <tr> <td>To Visual Monitor Facility-10</td> <td>3-5 cps</td> <td>↓</td> <td>↓</td> <td>↓</td> <td>1</td> </tr> <tr> <td>Select Line Facility-I</td> <td>-</td> <td>↓</td> <td>↓</td> <td>↓</td> <td>3</td> </tr> <tr> <td>To Select Line Facility-10</td> <td>-</td> <td>↓</td> <td>↓</td> <td>↓</td> <td>3</td> </tr> <tr> <td>Ring Line All</td> <td>-</td> <td>↓</td> <td>↓</td> <td>↓</td> <td>2</td> </tr> <tr> <td>Select Line Interphones</td> <td>-</td> <td>↓</td> <td>↓</td> <td>↓</td> <td>2</td> </tr> <tr> <td>Select Line Dial Line-I</td> <td>-</td> <td>↓</td> <td>↓</td> <td>↓</td> <td>5</td> </tr> <tr> <td>Visual Monitor Dial Line-I</td> <td>3-5 cps</td> <td>↓</td> <td>↓</td> <td>↓</td> <td>1</td> </tr> <tr> <td>Select Line Dial Line-II</td> <td>-</td> <td>↓</td> <td>↓</td> <td>↓</td> <td>5</td> </tr> <tr> <td>Visual Monitor Dial Line-II</td> <td>-</td> <td>↓</td> <td>↓</td> <td>↓</td> <td>1</td> </tr> <tr> <td>Select Line - HF Radio</td> <td>-</td> <td>↓</td> <td>↓</td> <td>↓</td> <td>5</td> </tr> <tr> <td>Visual Monitor HF Radio</td> <td>3-5 cps</td> <td>↓</td> <td>↓</td> <td>↓</td> <td>1</td> </tr> <tr> <td>Radio Key Signal</td> <td>-</td> <td>↓</td> <td>↓</td> <td>↓</td> <td>2</td> </tr> <tr> <td>Select Line - UHF Radio</td> <td>-</td> <td>↓</td> <td>↓</td> <td>↓</td> <td>3</td> </tr> <tr> <td>Visual Monitor UHF Radio</td> <td>3-5 cps</td> <td>↓</td> <td>↓</td> <td>↓</td> <td>1</td> </tr> <tr> <td>Select Line - VHF Radio</td> <td>-</td> <td>↓</td> <td>↓</td> <td>↓</td> <td>3</td> </tr> <tr> <td>Visual Monitor VHF Radio</td> <td>3-5 cps</td> <td>↓</td> <td>↓</td> <td>↓</td> <td>1</td> </tr> <tr> <td>Select Direct Line</td> <td>-</td> <td>↓</td> <td>↓</td> <td>↓</td> <td>3</td> </tr> <tr> <td>Visual Monitor Direct Line</td> <td>3-5 cps</td> <td>↓</td> <td>↓</td> <td>↓</td> <td>1</td> </tr> <tr> <td>Select EWO I</td> <td>-</td> <td>↓</td> <td>↓</td> <td>↓</td> <td>3</td> </tr> <tr> <td>Visual Monitor EWO I</td> <td>-</td> <td>↓</td> <td>↓</td> <td>↓</td> <td>1</td> </tr> <tr> <td>Select HVC</td> <td>-</td> <td>↓</td> <td>↓</td> <td>↓</td> <td>3</td> </tr> <tr> <td>Visual Monitor HVC</td> <td>3-5 cps</td> <td>↓</td> <td>↓</td> <td>↓</td> <td>1</td> </tr> <tr> <td>Ring Line HVC (5 separate Ring Lines)</td> <td>-</td> <td>↓</td> <td>↓</td> <td>↓</td> <td>5</td> </tr> <tr> <td>Select EWO II</td> <td>-</td> <td>↓</td> <td>↓</td> <td>↓</td> <td>3</td> </tr> <tr> <td>Visual Monitor EWO II</td> <td>3-5 cps</td> <td>↓</td> <td>↓</td> <td>↓</td> <td>1</td> </tr> </tbody> </table>			SOURCE	VOLTAGE	TOLERANCE	FREQUENCY	TOLERANCE	POWER	PHASE	WIRES	6207	-24V	±1%	DC	N.A.	40W	N.A.	N.A.	<u>SIGNAL NAMES</u>	<u>SIGNAL FREQUENCY</u>	<u>DB LEVEL</u>	<u>VOLT LEVEL</u>	<u>INTERFACE W/ CEI NO.</u>	<u>NO. OF LINES</u>	Visual Monitor Facility-I	3-5 cps	N.A.	0 to -24VDC	140067A 140068A 140069A	1	To Visual Monitor Facility-10	3-5 cps	↓	↓	↓	1	Select Line Facility-I	-	↓	↓	↓	3	To Select Line Facility-10	-	↓	↓	↓	3	Ring Line All	-	↓	↓	↓	2	Select Line Interphones	-	↓	↓	↓	2	Select Line Dial Line-I	-	↓	↓	↓	5	Visual Monitor Dial Line-I	3-5 cps	↓	↓	↓	1	Select Line Dial Line-II	-	↓	↓	↓	5	Visual Monitor Dial Line-II	-	↓	↓	↓	1	Select Line - HF Radio	-	↓	↓	↓	5	Visual Monitor HF Radio	3-5 cps	↓	↓	↓	1	Radio Key Signal	-	↓	↓	↓	2	Select Line - UHF Radio	-	↓	↓	↓	3	Visual Monitor UHF Radio	3-5 cps	↓	↓	↓	1	Select Line - VHF Radio	-	↓	↓	↓	3	Visual Monitor VHF Radio	3-5 cps	↓	↓	↓	1	Select Direct Line	-	↓	↓	↓	3	Visual Monitor Direct Line	3-5 cps	↓	↓	↓	1	Select EWO I	-	↓	↓	↓	3	Visual Monitor EWO I	-	↓	↓	↓	1	Select HVC	-	↓	↓	↓	3	Visual Monitor HVC	3-5 cps	↓	↓	↓	1	Ring Line HVC (5 separate Ring Lines)	-	↓	↓	↓	5	Select EWO II	-	↓	↓	↓	3	Visual Monitor EWO II	3-5 cps	↓	↓	↓	1
SOURCE	VOLTAGE	TOLERANCE	FREQUENCY	TOLERANCE	POWER	PHASE	WIRES																																																																																																																																																																													
6207	-24V	±1%	DC	N.A.	40W	N.A.	N.A.																																																																																																																																																																													
<u>SIGNAL NAMES</u>	<u>SIGNAL FREQUENCY</u>	<u>DB LEVEL</u>	<u>VOLT LEVEL</u>	<u>INTERFACE W/ CEI NO.</u>	<u>NO. OF LINES</u>																																																																																																																																																																															
Visual Monitor Facility-I	3-5 cps	N.A.	0 to -24VDC	140067A 140068A 140069A	1																																																																																																																																																																															
To Visual Monitor Facility-10	3-5 cps	↓	↓	↓	1																																																																																																																																																																															
Select Line Facility-I	-	↓	↓	↓	3																																																																																																																																																																															
To Select Line Facility-10	-	↓	↓	↓	3																																																																																																																																																																															
Ring Line All	-	↓	↓	↓	2																																																																																																																																																																															
Select Line Interphones	-	↓	↓	↓	2																																																																																																																																																																															
Select Line Dial Line-I	-	↓	↓	↓	5																																																																																																																																																																															
Visual Monitor Dial Line-I	3-5 cps	↓	↓	↓	1																																																																																																																																																																															
Select Line Dial Line-II	-	↓	↓	↓	5																																																																																																																																																																															
Visual Monitor Dial Line-II	-	↓	↓	↓	1																																																																																																																																																																															
Select Line - HF Radio	-	↓	↓	↓	5																																																																																																																																																																															
Visual Monitor HF Radio	3-5 cps	↓	↓	↓	1																																																																																																																																																																															
Radio Key Signal	-	↓	↓	↓	2																																																																																																																																																																															
Select Line - UHF Radio	-	↓	↓	↓	3																																																																																																																																																																															
Visual Monitor UHF Radio	3-5 cps	↓	↓	↓	1																																																																																																																																																																															
Select Line - VHF Radio	-	↓	↓	↓	3																																																																																																																																																																															
Visual Monitor VHF Radio	3-5 cps	↓	↓	↓	1																																																																																																																																																																															
Select Direct Line	-	↓	↓	↓	3																																																																																																																																																																															
Visual Monitor Direct Line	3-5 cps	↓	↓	↓	1																																																																																																																																																																															
Select EWO I	-	↓	↓	↓	3																																																																																																																																																																															
Visual Monitor EWO I	-	↓	↓	↓	1																																																																																																																																																																															
Select HVC	-	↓	↓	↓	3																																																																																																																																																																															
Visual Monitor HVC	3-5 cps	↓	↓	↓	1																																																																																																																																																																															
Ring Line HVC (5 separate Ring Lines)	-	↓	↓	↓	5																																																																																																																																																																															
Select EWO II	-	↓	↓	↓	3																																																																																																																																																																															
Visual Monitor EWO II	3-5 cps	↓	↓	↓	1																																																																																																																																																																															

REVISION 2 APPROVAL _____ DATE 4 Jun 1965 PAGE NO. 6 OF 13

Figure 47 (Continued). Design Sheet for Communications Control Panel.

DESIGN SHEET	NOMENCLATURE COMMUNICATIONS CONTROL PANEL (CCP)	CEI NO. OR CRITICAL COMPONENT CODE IDENTIFICATION <u>345678A</u> DETAIL SPEC NO. _____
--------------	--	---

REQUIREMENTS FOR DESIGN AND TEST

APPENDIX 10-3 (b) (Cont.)

TABLE II
SIGNAL INTERFACES

<u>SIGNAL NAMES</u>	<u>SIGNAL FREQUENCY</u>	<u>DB LEVEL</u>	<u>VOLT LEVEL</u>	<u>INTERFACE/W CEI NO.</u>	<u>NO. OF LINES</u>
Ring Line EWO II (3 separate Ring Lines)	-	N.A.	0 to -24VDC	1-00067A 1-00068A 1-00069A	5
Lamp Test	-	↓	↓	↓	6
Select HF Monitor	-	↓	↓	↓	2
Select VHF Monitor	-	↓	↓	↓	2
Select UHF Monitor	-	↓	↓	↓	2
Select Tel Monitor	-	↓	↓	↓	2
Handset/Headset Output	Audio	-15DBM	-	↓	2
Handset/Headset Input	Audio	-10DBM	-	↓	2
Monitor and Alarm	Audio	-	-	↓	2

REVISION B APPROVAL _____ DATE 4 Jun 1965 PAGE NO. 7 OF 13

Figure 47 (Continued). Design Sheet for Communications Control Panel.

DESIGN SHEET	NOMENCLATURE COMMUNICATIONS CONTROL PANEL (CCP)	CEI NO. OR CRITICAL COMPONENT CODE IDENTIFICATION 3-5270A DETAIL SPEC NO. _____
REQUIREMENTS FOR DESIGN AND TEST		
<p>.. Quality Assurance Provisions</p> <p>a) Performance, design, and construction requirements specified in Section 3. are formally verified by the provisions of this section. Formal verification shall establish acceptance of design and development engineering.</p> <p>b) Each requirement appearing in Section 3. is associated with:</p> <p>(1) verification method(s)</p> <p>(2) test category(s)</p> <p>(3) subparagraphs of Section 4. where the verification of each Section 3. requirement has been accommodated.</p> <p>c) A reference index provides for accountability of each Section 3. requirement and corresponding Section 4. verification provision. The index follows paragraph 4.2.</p> <p>4.1 Category I Test</p> <p>4.1.1 Engineering Test and Evaluation - Not applicable.</p> <p>4.1.2 Preliminary Qualification Tests - Not applicable.</p> <p>4.1.3 Formal Qualification Tests</p> <p>Formal qualification tests shall be conducted to satisfy specific requirements of the procuring agency to verify that all requirements of Section 3. are satisfied. Successful accomplishment of the verification shall constitute acceptance of design and development engineering. Requirements of Section 3. which deal in CEI reliability are covered separately in paragraph 4.1.4.</p> <p>Verifications are organized in subparagraphs according to the method of accomplishment. The methods are (1) inspection, (2) review of analytical data, (3) demonstration, and (4) test.</p> <p>4.1.3.1 Inspection</p> <p>The following requirements of Section 3. shall be verified by inspection of the CEI at the time and place of qualification testing.</p> <p>3.1.2.6 Human Performance</p> <p>3.2.7.1 Personnel Safety</p> <p>3.3 Interface Requirements</p> <p>3.3.1 Schematic Arrangement</p> <p>3.2.1.2 Detailed Interface Definition</p> <p>3.3.1 General Design Features</p> <p>3.3.2 Selection of Specifications and Standards</p> <p>3.3.3 Materials, Parts, and Processes</p> <p>3.3.4 Standard and Commercial Parts</p> <p>3.3.5 Moisture and Fungus Resistance</p> <p>3.3.6 Corrosion of Metal Parts</p> <p>3.3.8 Workmanship</p> <p>3.3.9 Electromagnetic Interference</p> <p>3.3.10 Identification and Marking</p> <p>4.1.3.2 Review of Analytical Data</p> <p>The listed requirements of Section 3. shall be verified by Review of Analytical Data.</p> <p>3.1.2.1 Reliability; See 4.1.4.</p> <p>4.1.3.3 Demonstrations</p> <p>The following requirements of Section 3. shall be verified by demonstration.</p> <p>a) (3.1.1) Functional Characteristics</p> <p>Verification of functional characteristics shall be accomplished by</p>		

REVISION B APPROVAL _____ DATE 4 Jun 1965 PAGE NO. 3 OF 13

Figure 47 (Continued). Design Sheet for Communications Control Panel.

DESIGN SHEET	NOMENCLATURE COMMUNICATIONS CONTROL PANEL (CCP)	CEILING OF CRITICAL COMPONENT CODE IDENTIFICATION 345678A DETAIL SPEC NO _____
REQUIREMENTS FOR DESIGN AND TEST		
<p>demonstrations conducted under subparagraphs b and c.</p> <p>b) (3.1.1.1) Primary Performance Characteristics Demonstrate, by random selection among the various communications paths, the ability of the CCP to connect with any of such appropriately simulated communications paths. The demonstration shall include, by appropriate simulation techniques, verification of the CCP characteristics required by paragraph 3.1.1.1.</p> <p>c) (3.1.1.2) Secondary Performance Characteristics. Demonstrate operation of switching controls and lock-unlock-release provisions for these controls. The demonstration shall include simulated termination of the voice paths for all switch banks.</p> <p>d) (3.1.2.2.1) Maintainability Demonstrate, by selection among components designated for organizational maintenance, and employing appropriate procedures, that the MTRF is within required limits. The items selected shall be determined by random selection. The demonstration shall include one (1) randomly selected field maintenance item.</p> <p>e) (3.1.2.2.2) Maintenance Repair Cycle One demonstration shall be conducted of the scheduled organizational maintenance employing appropriate procedures. Use of panel removal tool shall be demonstrated. The time factor for the scheduled maintenance shall be adjusted to compensate for technician familiarity, and approved by the justification team.</p> <p>f) (3.1.2.2.3) Service and Access The demonstration required by e. shall include verification of service and access requirements.</p> <p>g) (3.1.2.5) Transportability A demonstration shall be conducted to prepare two CCP units for movement, and shall include movement of these units from the place of packing/packaging to the environmental test location. The demonstration shall verify inclusion of all required packing/packaging provisions for the CCPs.</p> <p>h) (3.1.2.5) Noise and Vibration Demonstrate that no components simulate sounds produced by the audible signaling devices in conjunction with the primary performance characteristics demonstration required in 4.1.3.3.</p> <p>i) (3.3.7) Interchangeability and Replaceability Interchangeability of the CCP shall be demonstrated by random selection of a CCP and subsequent installation in the console required for demonstrations of d, e, f, and g. The requirement that a CCP is interchangeable in terms of any console implies that one console shall be compatible with any CCP.</p> <p>4.1.3.4 Tests The following requirements of Section 3. shall be satisfied by test and review of test data.</p> <p>3.1.2.4.1 Non-Operating Conditions, Environmental 3.1.2.4.2 Operating Conditions, Environmental Environmental tests shall be conducted to verify that the CCP performs properly during or following being subjected to various environments. Two units shall be utilized for all environmental tests. Before testing begins, these units shall be arbitrarily assigned control numbers CCP-1 and CCP-2.</p>		

REVISION B APPROVAL _____ DATE 4 Jun 1965 PAGE NO. 9 OF 13

Figure 47 (Continued). Design Sheet for Communications Control Panel.

10 March 1966

AFSCM 375-5

DESIGN SHEET	NOMENCLATURE COMMUNICATIONS CONTROL PANEL (CCP)	CEILING OR CRITICAL COMPONENT CODE IDENTIFICATION <u>345675A</u> DETAIL SPEC NO _____
REQUIREMENTS FOR DESIGN AND TEST		
<p>a) Storage Tests CCP-1 shall be stored, in its shipping container, for a period of not more than 15 days at a temperature of -65°F and a pressure of 23.0 inches mercury, at a relative humidity approximately 100%. At the end of this period, the packaged unit shall be returned to ambient temperature and unpacked. The unit shall be examined for indications of damage, and then shall be subjected to one operating cycle. The equipment shall then be subjected to shock testing.</p> <p>b) Shock Testing CCP-1 shall withstand applied shocks, with the equipment operating, which shall not cause equipment damage and/or malfunction. Acceleration peaks of 200G shall be applied and measured at the normal point of CCP attachment. One shock in each of the six directions shall be applied. This unit shall then be employed for non-operating vibration testing. The relative humidity during shock testing will not be controlled.</p> <p>c) Vibration Testing Non-operating CCP-1 shall be subjected to sinusoidal vibrations of 3.5G RMS from 5 to 50 cps (limited to 0.4 inch double amplitude), and also 1.5G RMS from 50 to 300 cps. Sweep duration shall be limited to one sweep at one-half octave per minute, both increasing and decreasing in frequency, applied in each mutually perpendicular axis. CCP-1 shall then be operated 3 cycles. CCP-1 condition shall be evaluated at the conclusion of this test and a recommendation prepared for its disposition. The Material Review Board shall make the final disposition decision.</p> <p>d) Altitude Tests CCP-2, in its packaged condition, shall be subjected to a high altitude test. The unit shall be placed in a cold chamber and the temperature shall be reduced at the rate of 5°F per minute until the temperature reaches -65°F at a pressure of 3.44 inches of mercury. The temperature and pressure shall be maintained for a period not to exceed 50 hours. The unit shall then be returned to ambient temperature, unpacked and inspected for damage. The unit shall then be subjected to one operating cycle before proceeding to high temperature storage tests.</p> <p>e) CCP-3 shall be subjected to an environmental temperature of 150°F for a period not to exceed 15 days and a relative humidity of 40% to compensate for nonprotective packaging. At the end of this period the CCP shall be returned to ambient temperature, and at a pressure of 23.09 inches of mercury shall be subjected to operating vibration testing.</p> <p>f) Vibration Testing, Operating CCP-2 shall be subjected to sinusoidal vibrations of 3G RMS from 2 to 8 cps (limited to 6 inches double amplitude), and also 2G RMS from 8 to 2000 cps. Sweep duration shall be limited to one sweep at one-half octave per minute, both increasing and decreasing in frequency, applied in each mutually perpendicular axis. CCP-2 shall be energized during these tests, and shall be operated 3 cycles upon termination of the vibration sequence. CCP-2 condition shall be evaluated at the conclusion of this test and a recommendation prepared for its disposition. The Material Review Board shall make the final disposition decision.</p> <p>4.1.4 Reliability Test and Analysis Verification of reliability factors specified in paragraph 3.1.2.1 shall be</p>		

REVISION 3 APPROVAL _____ DATE 4 Jun 1965 PAGE NO. 10 OF 13

Figure 47 (Continued). Design Sheet for Communications Control Panel.

10 March 1966

DESIGN SHEET	NOMENCLATURE COMMUNICATIONS CONTROL PANEL (CCP)	CEI NO. OR CRITICAL COMPONENT CODE IDENTIFICATION <u>345E78A</u> DETAIL SPEC NO. _____
REQUIREMENTS FOR DESIGN AND TEST		
<p>accomplished by review and comparison of analytical and component historical data.</p> <p>The analytical data source shall be the systems engineering reliability analysis documentation. The historical data source shall consist of CCP component histories. These histories shall include test, production volume, production lot sizes, lot failure rates and codes, lot acceptance test rates, lot use failure rates and codes, and marginal application histories.</p> <p>The historical data shall be evaluated and or existing evaluations shall be compared against reliability analysis predictions. The comparisons shall be based on the log normal distribution of failures, and appropriate statistical techniques shall be employed to conclude the analysis.</p> <p>4.1.5 Engineering Critical Component Qualification - Not applicable.</p> <p>4.2 Category II Test - Not applicable.</p>		

REVISION B APPROVAL _____ DATE 4 Jun 1965 PAGE NO. 11 OF 13

Figure 47 (Continued). Design Sheet for Communications Control Panel.

10 March 1966

AFSCM 375-5

DESIGN SHEET		NOMENCLATURE COMMUNICATIONS CONTROL PANEL (CCP)					CEI NO OR CRITICAL COMPONENT CODE IDENTIFICATION <u>4567EA</u> DETAIL SPEC NO _____					
REQUIREMENTS FOR DESIGN AND TEST												
VERIFICATION CROSS REFERENCE INDEX												
<p>METHOD LEGEND: N.A. - Not Applicable 2 - Review of Analytical Data 1 - Inspection 3 - Demonstration 4 - Test</p> <p>QAT. 1 LEGEND: A-Engineering Test & Evaluation B-Preliminary Qualification C-Formal Qualification D-Reliability Test & Analysis E-Engineering Critical Component Qualification</p>												
SECTION 3.0 REQUIREMENT REFERENCE	VERIFICATION METHOD(S)					TEST CATEGORY					SECTION 4.0 VERIFICATION REQUIREMENT	
	NA	1	2	3	4	A	B	C	D	E		
3.0	x											
3.1	x											
3.1.1				x				x				4.1.3.3a
3.1.1.1				x				x				4.1.3.3b
3.1.1.2				x				x				4.1.3.3c
3.1.2	x											
3.1.2.1			x						x			4.1.3.3, -1.1
3.1.2.2	x											
3.1.2.2.1				x				x				4.1.3.3d
3.1.2.2.2				x				x				4.1.3.3e
3.1.2.2.3				x				x				4.1.3.3f
3.1.2.3	x											
3.1.2.4	x											
3.1.2.4.1					x			x				4.1.3.4
3.1.2.4.2					x			x				4.1.3.4
3.1.2.5				x				x				4.1.3.3g
3.1.2.6		x						x				4.1.3.1
3.1.2.7	x											
3.1.2.7.1		x						x				4.1.3.1
3.1.2.7.2	x											
3.1.2.8				x				x				4.1.3.3h
3.2	x											
3.2.1		x						x				4.1.3.1
3.2.1.1		x						x				4.1.3.1
3.2.1.2		x						x				4.1.3.1
3.2.2	x											
3.2.2.1	x											
3.2.2.2	x											
3.2.2.3	x											

REVISION B APPROVAL _____ DATE 4 Jun 1965 PAGE NO. 12 OF 13

Figure 47 (Continued). Design Sheet for Communications Control Panel.

DESIGN SHEET	NOMENCLATURE COMMUNICATIONS CONTROL PANEL (CCP)	DETAILED CRITICAL COMPONENT CODE IDENTIFICATION <u>1-5678A</u> DETAIL SPEC NO _____
--------------	--	--

REQUIREMENTS FOR DESIGN AND TEST

VERIFICATION CROSS REFERENCE INDEX (Cont.)

METHOD LEGEND: N/A - Not Applicable R - Review of Analytical Data
 I - Inspection D - Demonstration T - Test

TEST CATEGORY LEGEND: A-Engineering Test & Evaluation B-Preliminary Qualification
 C-Formal Qualification D-Reliability Test & Analysis
 E-Engineering Critical Component Qualification

SECTION 3.0 REQUIREMENT REFERENCE	VERIFICATION METHOD(S)					TEST CATEGORY					SECTION 4.0 VERIFICATION REQUIREMENT	
	NA	I	D	T	R	I						II
						A	B	C	D	E		
4.1.3.1	X							X				
4.1.3.1		X						X				4.1.3.1
4.1.3.1		X						X				4.1.3.1
4.1.3.1		X						X				4.1.3.1
4.1.3.1		X						X				4.1.3.1
4.1.3.1		X						X				4.1.3.1
4.1.3.1					X			X				4.1.3.31
4.1.3.1		X						X				4.1.3.1
4.1.3.1		X						X				4.1.3.1
4.1.3.1	X							X				4.1.3.1

REVISION B APPROVAL _____ DATE 6 Jun 1965 PAGE NO. 13 OF 13

Figure 47 (Continued). Design Sheet for Communications Control Panel.

10 March 1966

AFSCM 375-

11.0 FACILITY INTERFACE SHEET. Figure 48
is an example of a facility interface sheet for an

electro-theodolite set. azimuth alignment.

FACILITY INTERFACE SHEET		REFERENCE FUNCTION	
ORGANIZATION	SYMBOL CATEGORY	SYMBOL CATEGORY	SYMBOL CATEGORY
AF, Electromagnetic Interference	(1) VENTILATION BRICKS (2) TEMPERATURE AND HUMIDITY (3) FORCED VENTILATION AIR CHANGES (S/S) (4) ILLUMINATION (5) PERSONNEL OCCUPANCY (H A)	(1) ELECTROMAGNETIC INTERFERENCE COMPATIBILITY (2) CONTAMINATION LEVEL (H A) (3) HAZARDOUS SAFETY (4) HEAT REJECTION RATE (5) CRITICAL TIME FACTORS (H A) (6) OTHER SPECIAL REQUIREMENTS	(1) DEVELOPER AND WEIGHT (2) ADAPTIVE PROVIDEDS (3) ELECTRICAL POWER (4) ELECTRICAL GROUNDING (5) WATER AND GAS SERVICE (H A) (6) ACCESS (7) POSITION LOCATION (8) HAZARDOUS PROVIDEDS (H A) (9) FIRE HAZARD PROVIDEDS (H A) (10) OTHER SPECIAL INTERFACE CONSIDERATIONS
(1) The LBASIS will withstand overall random acoustic energy of 120dB over a frequency range 31.5 cps to 10,000 cps for 10 seconds.			(1) The LBASIS envelope will be designed for a weight of 2000 lbs. weight will be approximately 2000 lbs.
(2) Range of 40° F to 40° F and relative humidity of 0-55			(2) Shelter is required to protect LBASIS from weather and ground level effects consistent with humidity and temperature, and to protect cables and penetrations.
(4) 170 foot candles for small details, to a brightness contrast, plus supplementary			(3) A concrete floor shall be provided for the shelter. The floor shall be finished with a smooth surface. The floor shall be finished with a smooth surface. The floor shall be finished with a smooth surface.
(6) LBASIS is designed for a minimum of self-generated radio interference and maximum susceptibility to electro-interference per MIL-STD-461C. Preparation and supporting equipment must use best available practices in shielding, construction and grounding.			(4) LBASIS will be designed for a minimum of self-generated radio interference and maximum susceptibility to electro-interference per MIL-STD-461C. Preparation and supporting equipment must use best available practices in shielding, construction and grounding.
(8) No fungus resistant materials shall be used (see per MIL-STD-883C)			(5) Power interconnection to be in accordance with the MIL-STD-883C Group I location specifications.
(9) Heat rejection rate for LBASIS is _____ B.T.U./H.			(6) Grounding shall be separately (from facilities provided by user) where available. Installation will not exceed 100 ohms impedance per MIL-STD-461C.
(11) A minimum of 7 days without LBASIS requalification (derive vehicle number)			(7) Panels and controls will be located within the shelter. Controls shall be clearly marked and labeled. Panels and controls will be clearly marked and labeled. Panels and controls will be clearly marked and labeled.
			(8) Location of LBASIS within the shelter will be as follows: (a) 10 feet from the shelter entrance. (b) 10 feet from the shelter entrance. (c) 10 feet from the shelter entrance.
			(9) A minimum of 7 days without LBASIS requalification (derive vehicle number)

DESIGN NO. _____ DATE: 10 Mar 1966 APPROVAL: _____ ACCOUNT NO. _____ FIG. NO. _____ OF _____

Figure 48. An Electro Interference Set for Facility Interface Sheet.

10 March 1966

AFSCM 375-1)

12.0 END ITEM MAINTENANCE SHEET. Figure 49 is an example of an end item maintenance sheet for a telephone repeater which is the sec-

ond indenture of radio set AM-GRC 132. A portion of the corresponding RAS for the test maintenance function is shown in figure 50.

LINE ITEM	CONDITION MAINTENANCE SHEET		METS STATUS		MAINTENANCE FUNCTIONS										MAINT LOGS			NAME LOCATION		MCS (10-10-60)		Administrative PL Number Data													
	IDENTIFICATION	DESCRIPTION	WIP	ASMB	INSTALL	TEST OF CHECK	CALLS & ADJ	REMOVE INSTALL	REPLACE	REPR OVERHAUL	PROTECT MBY	VIS CHECK MBY	CLEAN FORCE FILTER DECONTAMINATE	COMPOSITE TEST	SYSTEM ALIGN	STORE HANDLE	MONITOR OPERATE	OTHER	INTERFACE	PREVENTIVE	CORRECTIVE	EMERGENCY	SHELF LIFE	ICC MLO MM	SUPPLY BASE	ASB	ISA	SOURCE CODE	EBRC CODE	ADP	QTY ASSEM	QUANT ARTICLE			
1																																			
2																																			
3																																			
4																																			
5																																			
6																																			
7																																			
8																																			
9																																			
10																																			
11																																			
12																																			

Figure 49 End Item Maintenance Sheet for Telephone Repeater.

REQUIREMENTS ALLOCATION SHEET		Functional Diagram Title and No.		Equipment Identification		PERSONNEL AND TRAINING EQUIPMENT REQUIREMENTS				Procedural Date Requirements
Function Name & Number	Design Requirements	Facility Requirements	Requirements and No. of CEI	Nomenclature	CEI or Detail Spot or Master Control Number	Tasks	Time Req	Performance Requirements	Eng & Insp Equip Req	
1.01.01	1.01.01.01: The system shall be capable of receiving and processing signals from the ground station and relaying them to the aircraft. The system shall be capable of receiving and relaying signals from the aircraft to the ground station. The system shall be capable of receiving and relaying signals from the aircraft to the ground station. The system shall be capable of receiving and relaying signals from the aircraft to the ground station.									
1.01.02	1.01.02.01: The system shall be capable of receiving and processing signals from the ground station and relaying them to the aircraft. The system shall be capable of receiving and relaying signals from the aircraft to the ground station. The system shall be capable of receiving and relaying signals from the aircraft to the ground station. The system shall be capable of receiving and relaying signals from the aircraft to the ground station.									
1.01.03	1.01.03.01: The system shall be capable of receiving and processing signals from the ground station and relaying them to the aircraft. The system shall be capable of receiving and relaying signals from the aircraft to the ground station. The system shall be capable of receiving and relaying signals from the aircraft to the ground station. The system shall be capable of receiving and relaying signals from the aircraft to the ground station.									
1.01.04	1.01.04.01: The system shall be capable of receiving and processing signals from the ground station and relaying them to the aircraft. The system shall be capable of receiving and relaying signals from the aircraft to the ground station. The system shall be capable of receiving and relaying signals from the aircraft to the ground station. The system shall be capable of receiving and relaying signals from the aircraft to the ground station.									
1.01.05	1.01.05.01: The system shall be capable of receiving and processing signals from the ground station and relaying them to the aircraft. The system shall be capable of receiving and relaying signals from the aircraft to the ground station. The system shall be capable of receiving and relaying signals from the aircraft to the ground station. The system shall be capable of receiving and relaying signals from the aircraft to the ground station.									

Revision: _____ Date: _____ Approval: _____ Document Number: _____ Page Number: _____

Figure 50 BAS for Maintenance Function "Fast Telephone Repeater"

13.0 MAINTENANCE LOADING ANALYSIS:

13.1 Figure 51. Figure 51 is an example of a maintenance loading sheet illustrating the recording of maintenance information against functions by location. The MGE utilization appearing in column O is summarized on the MGE utilization sheet to determine total quantities of equipment. The personnel information recorded in column L is summarized by AFSC and location and presented in summary fashion on the personnel utilization sheet.

13.2 Figure 52. Figure 52 is an example of an MGE utilization sheet recording the use of MGE by location and recommended quantity of

equipment based on the recorded utilization. For the purpose of the example, it was assumed that 50 units were deployed (column C-1) and there was only one each of the other maintenance locations (columns C-2 through C-5).

13.3 Figure 53. Figure 53 is an example of a personnel utilization sheet illustrating the recording of time by location of each AFSC. This information is a compilation of the information appearing in column L of the maintenance loading sheet. Certain systems require extensive and continuous operational readiness training which should be accounted for in the formulation of the personnel utilization data.

Maintenance Category (MORT)	Circulation								Type of maintenance performed on objective	
	Time Log (MORT)	Number of Participants	Number of Participants	Number of Participants	Number of Participants	Number of Participants	Number of Participants	Number of Participants	Number of Participants	Number of Participants
Low (MORT 1) - [unclear] and [unclear]	1.00	1.00	1.00	1.00	1.00	1.00	1.00	1.00	1.00	1.00
Low (MORT 2) - [unclear]	1.00	1.00	1.00	1.00	1.00	1.00	1.00	1.00	1.00	1.00
Low (MORT 3) - [unclear]	1.00	1.00	1.00	1.00	1.00	1.00	1.00	1.00	1.00	1.00

SECTION B DATE 10 MAR 1966 APPROVAL [signature] CIRCULATION 1.00 PAGE 1 of 6

Figure 51. Maintenance Leading Sheet.

MAGCEN NUMBER	DESCRIPTION	QUANTITY IN USE BY ADMINISTRATION LOCATION										Quantity SECURE						
		1	2	3	4	5	6	7	8	9	10							
1001	5110 Handline				1000													
1002	Attachment 40				1000													
1003	Cable Assembly Set, Power Fluorescent		1000															
1004	Portable Tester G & C Counter	1000																
1005	Power Supply, DC Portable					1000												

FORM 100-1 (Rev. 1-55) DATE 15 Feb 1966 APPROVAL E. G. M. 18 DOCUMENT NO. 14875 PAGE NO. 1 of 4

Figure 52. MAGC Utilization.

AFSC	Title and AFSC Job	Personnel Utilization Summary										Total Man Months			
		1	2	3	4	5	6	7	8	9	10				
11A	Operations (11A)	1.1													1.1
11B	General Com Equipment Operator (11B)	1.1													1.1
11C	Engine System Mechanic	1.1													1.1
11D	Radio System Specialist	1.1													1.1
11E	Search & Rescue Equipment Operator	1.1													1.1
11F	Vehicle Operator	1.1													1.1
11G	Communications Specialist	1.1													1.1

AFSCM 375-5 1 of 5

Figure 53. Personnel Utilization

AFSCM 375-5

10 March 1966

14.0 CALIBRATION REQUIREMENTS SUMMARY.

Examples of excerpts from the CRS for a propulsion subsystem and a guidance subsystem are

shown in figure 54. Excerpts from the CRS for a rocket engine and a launch console are shown in figure 55.

C O M P O N E N T	Calculation Requirements Summary														
	OPERATIONAL ELEMENT CATEGORY				PERFORMANCE ELEMENT CATEGORY				PRECISION ELEMENT CATEGORY				CALCULATION ELEMENT CATEGORY		
REQ NO	DESCRIPTION	REQ NO	DESCRIPTION	REQ NO	DESCRIPTION	REQ NO	DESCRIPTION	REQ NO	DESCRIPTION	REQ NO	DESCRIPTION	REQ NO	DESCRIPTION		
1	Propulsion Subsystem	1	Propulsion Subsystem	1	Propulsion Subsystem	1	Propulsion Subsystem	1	Propulsion Subsystem	1	Propulsion Subsystem	1	Propulsion Subsystem		
2	Guidance Subsystem	2	Guidance Subsystem	2	Guidance Subsystem	2	Guidance Subsystem	2	Guidance Subsystem	2	Guidance Subsystem	2	Guidance Subsystem		
3	Control Subsystem	3	Control Subsystem	3	Control Subsystem	3	Control Subsystem	3	Control Subsystem	3	Control Subsystem	3	Control Subsystem		
4	Power Subsystem	4	Power Subsystem	4	Power Subsystem	4	Power Subsystem	4	Power Subsystem	4	Power Subsystem	4	Power Subsystem		
5	Structural Subsystem	5	Structural Subsystem	5	Structural Subsystem	5	Structural Subsystem	5	Structural Subsystem	5	Structural Subsystem	5	Structural Subsystem		

REQ NO 101100 - 4 APPROVAL NUMBER 200720 DOCUMENT NUMBER 200720 PAGE NUMBER 1 of 1

Figure 54. Excerpt from CRS for Propulsion Subsystem and Guidance Subsystem.

CALIBRATION REQUIREMENTS SUMMARY												
CAGE CODE	OPERATIONAL CATEGORY: CATEGORY I				PRECISION WEAS EQUIP: CATEGORY II				CALIBRATION EQUIP: CATEGORY III			
	SPECIFICATION RANGE AND ACCURACY		CALIBRATION INTERVAL		SPECIFICATION RANGE AND ACCURACY		CALIBRATION INTERVAL		SPECIFICATION RANGE AND ACCURACY		CALIBRATION INTERVAL	
	QTY	UNIT	TIME	PERIOD	QTY	UNIT	TIME	PERIOD	QTY	UNIT	TIME	PERIOD
01	0-50 0-100 0-200 0-300 0-400 0-500 0-600 0-700 0-800 0-900 0-1000	Pressure Group	1	1	1	1	1	1	1	1	1	1
02	0-100 0-200 0-300 0-400 0-500 0-600 0-700 0-800 0-900 0-1000	Pressure Group	1	1	1	1	1	1	1	1	1	1
03	0-100 0-200 0-300 0-400 0-500 0-600 0-700 0-800 0-900 0-1000	Pressure Group	1	1	1	1	1	1	1	1	1	1
04	0-100 0-200 0-300 0-400 0-500 0-600 0-700 0-800 0-900 0-1000	Pressure Group	1	1	1	1	1	1	1	1	1	1
05	0-100 0-200 0-300 0-400 0-500 0-600 0-700 0-800 0-900 0-1000	Pressure Group	1	1	1	1	1	1	1	1	1	1
06	0-100 0-200 0-300 0-400 0-500 0-600 0-700 0-800 0-900 0-1000	Pressure Group	1	1	1	1	1	1	1	1	1	1
07	0-100 0-200 0-300 0-400 0-500 0-600 0-700 0-800 0-900 0-1000	Pressure Group	1	1	1	1	1	1	1	1	1	1
08	0-100 0-200 0-300 0-400 0-500 0-600 0-700 0-800 0-900 0-1000	Pressure Group	1	1	1	1	1	1	1	1	1	1
09	0-100 0-200 0-300 0-400 0-500 0-600 0-700 0-800 0-900 0-1000	Pressure Group	1	1	1	1	1	1	1	1	1	1
10	0-100 0-200 0-300 0-400 0-500 0-600 0-700 0-800 0-900 0-1000	Pressure Group	1	1	1	1	1	1	1	1	1	1
11	0-100 0-200 0-300 0-400 0-500 0-600 0-700 0-800 0-900 0-1000	Pressure Group	1	1	1	1	1	1	1	1	1	1
12	0-100 0-200 0-300 0-400 0-500 0-600 0-700 0-800 0-900 0-1000	Pressure Group	1	1	1	1	1	1	1	1	1	1
13	0-100 0-200 0-300 0-400 0-500 0-600 0-700 0-800 0-900 0-1000	Pressure Group	1	1	1	1	1	1	1	1	1	1
14	0-100 0-200 0-300 0-400 0-500 0-600 0-700 0-800 0-900 0-1000	Pressure Group	1	1	1	1	1	1	1	1	1	1
15	0-100 0-200 0-300 0-400 0-500 0-600 0-700 0-800 0-900 0-1000	Pressure Group	1	1	1	1	1	1	1	1	1	1
16	0-100 0-200 0-300 0-400 0-500 0-600 0-700 0-800 0-900 0-1000	Pressure Group	1	1	1	1	1	1	1	1	1	1
17	0-100 0-200 0-300 0-400 0-500 0-600 0-700 0-800 0-900 0-1000	Pressure Group	1	1	1	1	1	1	1	1	1	1
18	0-100 0-200 0-300 0-400 0-500 0-600 0-700 0-800 0-900 0-1000	Pressure Group	1	1	1	1	1	1	1	1	1	1
19	0-100 0-200 0-300 0-400 0-500 0-600 0-700 0-800 0-900 0-1000	Pressure Group	1	1	1	1	1	1	1	1	1	1
20	0-100 0-200 0-300 0-400 0-500 0-600 0-700 0-800 0-900 0-1000	Pressure Group	1	1	1	1	1	1	1	1	1	1
21	0-100 0-200 0-300 0-400 0-500 0-600 0-700 0-800 0-900 0-1000	Pressure Group	1	1	1	1	1	1	1	1	1	1
22	0-100 0-200 0-300 0-400 0-500 0-600 0-700 0-800 0-900 0-1000	Pressure Group	1	1	1	1	1	1	1	1	1	1
23	0-100 0-200 0-300 0-400 0-500 0-600 0-700 0-800 0-900 0-1000	Pressure Group	1	1	1	1	1	1	1	1	1	1
24	0-100 0-200 0-300 0-400 0-500 0-600 0-700 0-800 0-900 0-1000	Pressure Group	1	1	1	1	1	1	1	1	1	1
25	0-100 0-200 0-300 0-400 0-500 0-600 0-700 0-800 0-900 0-1000	Pressure Group	1	1	1	1	1	1	1	1	1	1
26	0-100 0-200 0-300 0-400 0-500 0-600 0-700 0-800 0-900 0-1000	Pressure Group	1	1	1	1	1	1	1	1	1	1
27	0-100 0-200 0-300 0-400 0-500 0-600 0-700 0-800 0-900 0-1000	Pressure Group	1	1	1	1	1	1	1	1	1	1
28	0-100 0-200 0-300 0-400 0-500 0-600 0-700 0-800 0-900 0-1000	Pressure Group	1	1	1	1	1	1	1	1	1	1
29	0-100 0-200 0-300 0-400 0-500 0-600 0-700 0-800 0-900 0-1000	Pressure Group	1	1	1	1	1	1	1	1	1	1
30	0-100 0-200 0-300 0-400 0-500 0-600 0-700 0-800 0-900 0-1000	Pressure Group	1	1	1	1	1	1	1	1	1	1
31	0-100 0-200 0-300 0-400 0-500 0-600 0-700 0-800 0-900 0-1000	Pressure Group	1	1	1	1	1	1	1	1	1	1
32	0-100 0-200 0-300 0-400 0-500 0-600 0-700 0-800 0-900 0-1000	Pressure Group	1	1	1	1	1	1	1	1	1	1
33	0-100 0-200 0-300 0-400 0-500 0-600 0-700 0-800 0-900 0-1000	Pressure Group	1	1	1	1	1	1	1	1	1	1
34	0-100 0-200 0-300 0-400 0-500 0-600 0-700 0-800 0-900 0-1000	Pressure Group	1	1	1	1	1	1	1	1	1	1
35	0-100 0-200 0-300 0-400 0-500 0-600 0-700 0-800 0-900 0-1000	Pressure Group	1	1	1	1	1	1	1	1	1	1
36	0-100 0-200 0-300 0-400 0-500 0-600 0-700 0-800 0-900 0-1000	Pressure Group	1	1	1	1	1	1	1	1	1	1
37	0-100 0-200 0-300 0-400 0-500 0-600 0-700 0-800 0-900 0-1000	Pressure Group	1	1	1	1	1	1	1	1	1	1
38	0-100 0-200 0-300 0-400 0-500 0-600 0-700 0-800 0-900 0-1000	Pressure Group	1	1	1	1	1	1	1	1	1	1
39	0-100 0-200 0-300 0-400 0-500 0-600 0-700 0-800 0-900 0-1000	Pressure Group	1	1	1	1	1	1	1	1	1	1
40	0-100 0-200 0-300 0-400 0-500 0-600 0-700 0-800 0-900 0-1000	Pressure Group	1	1	1	1	1	1	1	1	1	1

FORM 10-10-1964 APPROVAL: [Signature] DOCUMENT NUMBER: 4400-10 PAGE NUMBER: 1 of 1

Figure 55. Excerpts from CFS for Becht Engine and Launch Console.

10 March 1966

AFSCM 375-5)

15.0 MGE PROVISIONING FIGURE A. Figure 56 is an example of an MGE provisioning fig-

ure A of AFPI 71-650 which reflects the modifications specified in attachment 1.

)

)

MAINTENANCE GROUND EQUIPMENT																	
PROVISIONING LIST																	
UNIT CODE	SYMBOL AND MODEL OF UNIT (MILITARY SYMBOLS)	REFERENCE SYMBOLS AND IFCM ELECTRONICS UNIT OPTIONAL FOR OTHERS	FEDERAL STOCK NUMBER	ITEM NAME		PRIME CONTRACTORS		QTY PER ASSY	QTY PER COMP	QTY PER UNIT	TOTAL MAXIMUM REQUIRED	UNIT PRICE	ESTIMATE UNIT PRICE	TOTAL ESTIMATE PRICE	REMARKS		
				ITEM AND LOT NO	FEDERAL SUPPLY CODE	PART NUMBER	MANUFACTURER										
10			14	10	REAROUT SET	10017000	10017000	1	1	1	1	10000.00	10000.00				
CONTRACT NUMBER										STANDARD SPALT LAUNCH VEHICLE						PAGE 1 OF 10	
CONTRACTOR										METERED SYSTEMS INC						DATE OF LIST 1 FEB 66	

Figure 56. Modified MGE Provisioning Figure.

10 March 1966

AFSCM 375-5

16.0 FACILITY PERSPECTIVE AND FACILITY SCHEMATIC DIAGRAMS. Figure 57 shows an example of a facility concept perspective illustrating the general layout and concept for a maintenance facility. Figure 58 is the site plan for the same facility concept, illustrating more detail, specific areas, and critical dimension

parameters. Figure 59 illustrates further detail development of work space within the maintenance facility. Figures 60 and 61 illustrate preliminary functional schematic diagrams used in the analysis, allocation, and development of design requirements for critical RPIE subsystems.

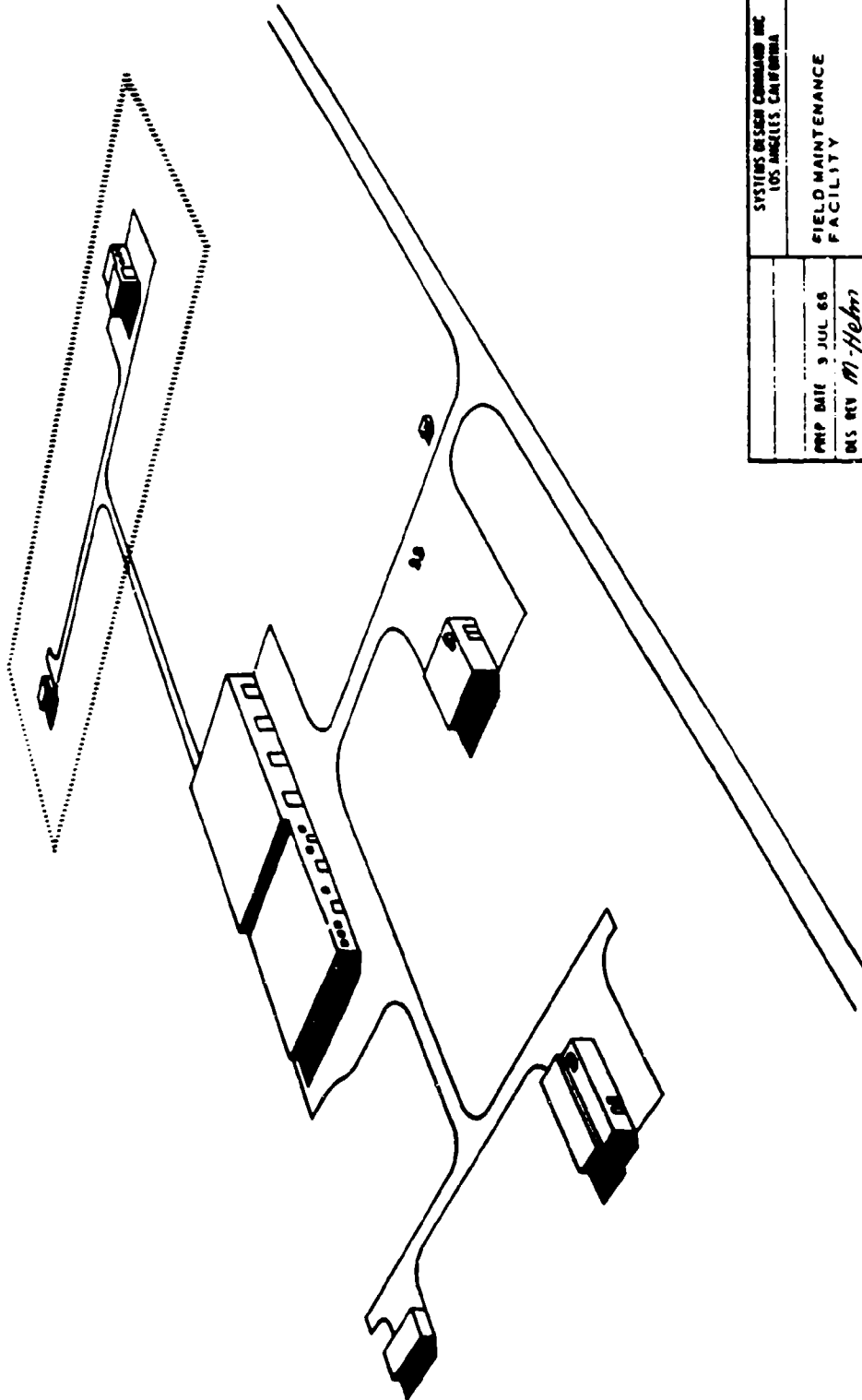

SYSTEMS DESIGN COMPANY INC LOS ANGELES, CALIFORNIA			
FIELD MAINTENANCE FACILITY			
PREP DATE	3 JUL 68	CONTRACT NO	4-7029
DLS REV	M-Hehn	SHEET NO	A
PROJ MGR	D. Bayless	SCALE	1 OF 1
DRY APP	B. Huey		

Figure 57. Facility Perspective for a Maintenance Facility.

10 March 1966

AFSC

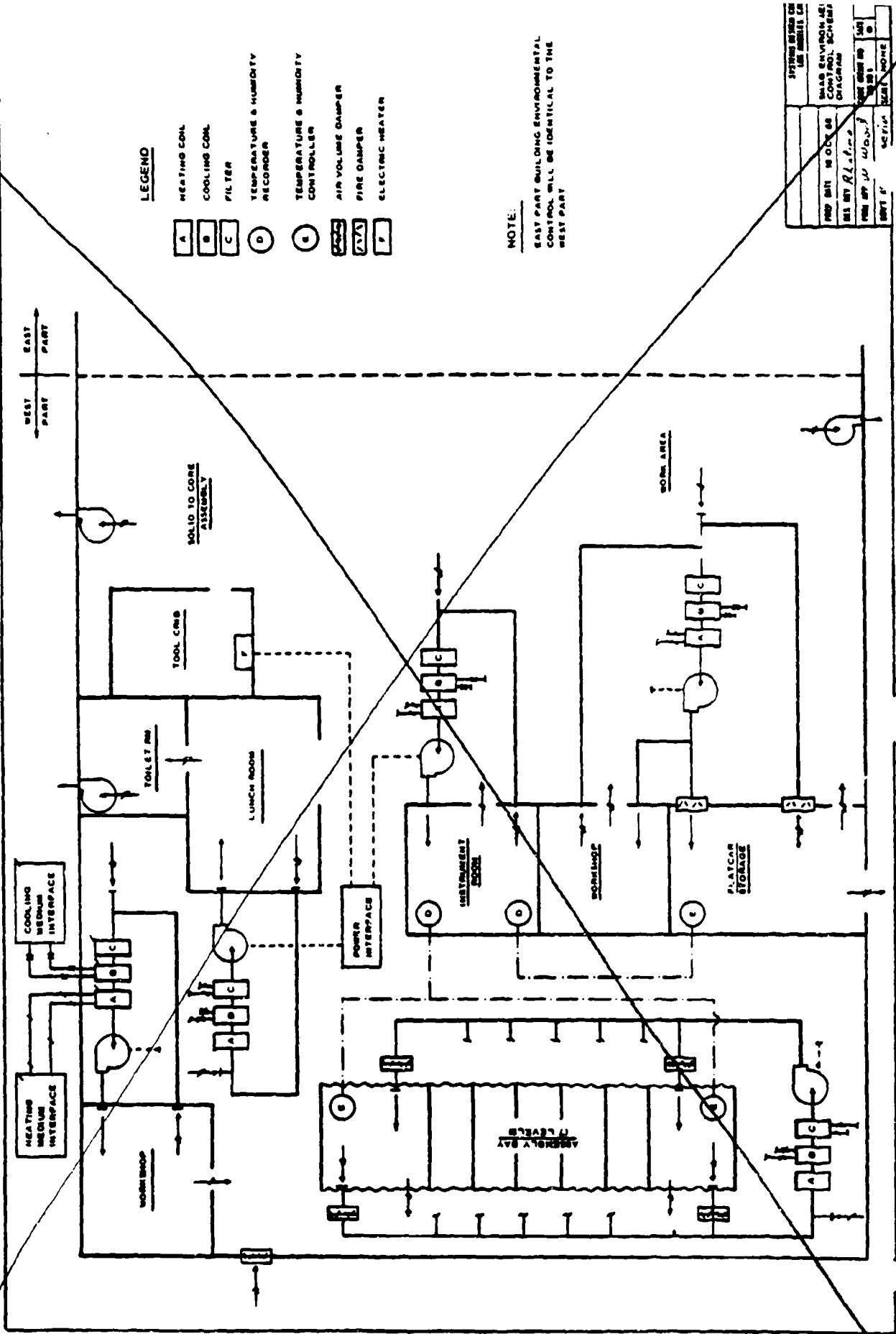

LEGEND

- A [Symbol]
- B [Symbol]
- C [Symbol]
- D [Symbol]
- E [Symbol]
- G [Symbol]
- H [Symbol]
- F [Symbol]

HEATING COIL
 COOLING COIL
 FILTER
 TEMPERATURE & HUMIDITY RECORDER
 TEMPERATURE & HUMIDITY CONTROLLER
 AIR VOLUME DAMPER
 FIRE DAMPER
 ELECTRIC HEATER

NOTE:

EAST PART BUILDING ENVIRONMENTAL CONTROL WILL BE IDENTICAL TO THE WEST PART

SYSTEMS ENGINEER	DATE	REVISION
DESIGNER	DATE	REVISION
CHECKED BY	DATE	REVISION
APPROVED BY	DATE	REVISION

Figure 60 Schematic Diagram for SHAB Environment: 1st Control

10 March 1966

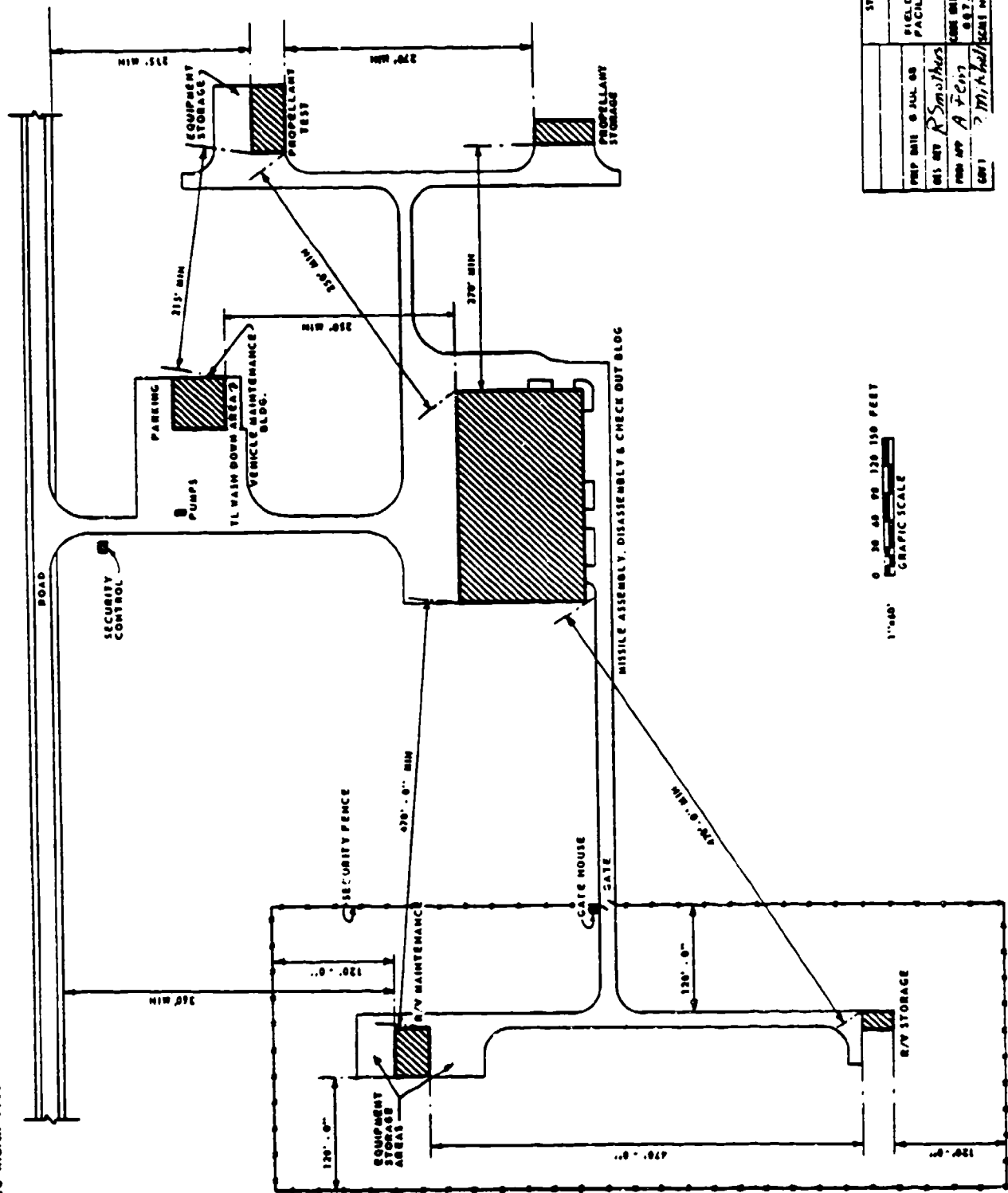

SYSTEMS	100
FIELD MAINT	
FACILITY	
PREP MAIL	6 JUL 68
MS RT	R Smothers
PROP MP	A F Ent
GMT	7 171, 164/164 HOME

0 30 60 90 120 150 FEET
 1"=60'
 GRAPHIC SCALE

Figure 5B Facility, Site Plan for Maintenance Facility

219/220

10 March 1964

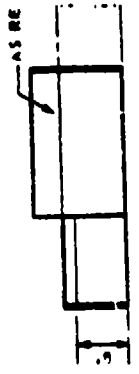

SECTION B

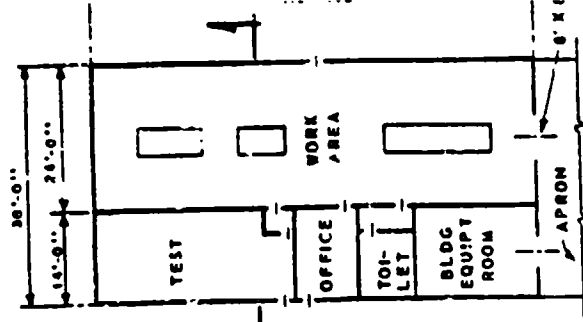

FLOOR PLAN

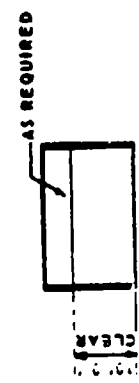

SECTION A

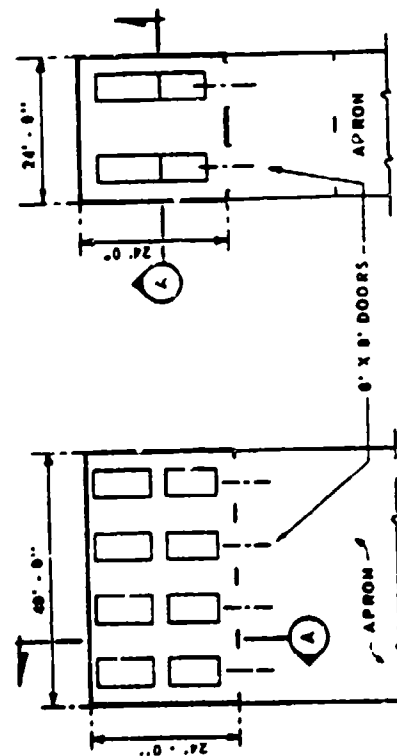

FLOOR PLAN

NOTES:
1. THESE TWO BUILDINGS CAN BE COMBINED WITHIN ONE (1) BUILDING

ROOM	SIZE (FT)	AREA (SQ. FT.)
TEST	14 X 26	364
OFFICE	14 X 16	224
TOILET	14 X 8	112
BUILDING EQUIPT. RM.	14 X 20	280
WORK AREA	24 X 70	1680
TOTAL BLDG	38 X 78	2660
STORAGE FOR 2 ASSEMBLED PROPELLANT PEGS	30 X 24	576
STORAGE FOR 8 SINGLE ENGINES	40 X 24	960

PROPELLANT STORAGE BLDGS
SEE NOTE NO. 1

7/16" = 1' 0"
0 8 16 24 32 40 FEET
GRAPHIC SCALE

PROPELLANT TEST BLDG

SYSTEMS DESIGNED BY	FIELD MAINT FACILITY PL
PREP DATE	10 JUL 68
DES BY	H Stein
CHKD BY	D. Gold, H. K. ...
DATE	...
SCALE	...

Figure 29. Mainstore Facility Floor Plan

10 March 1964

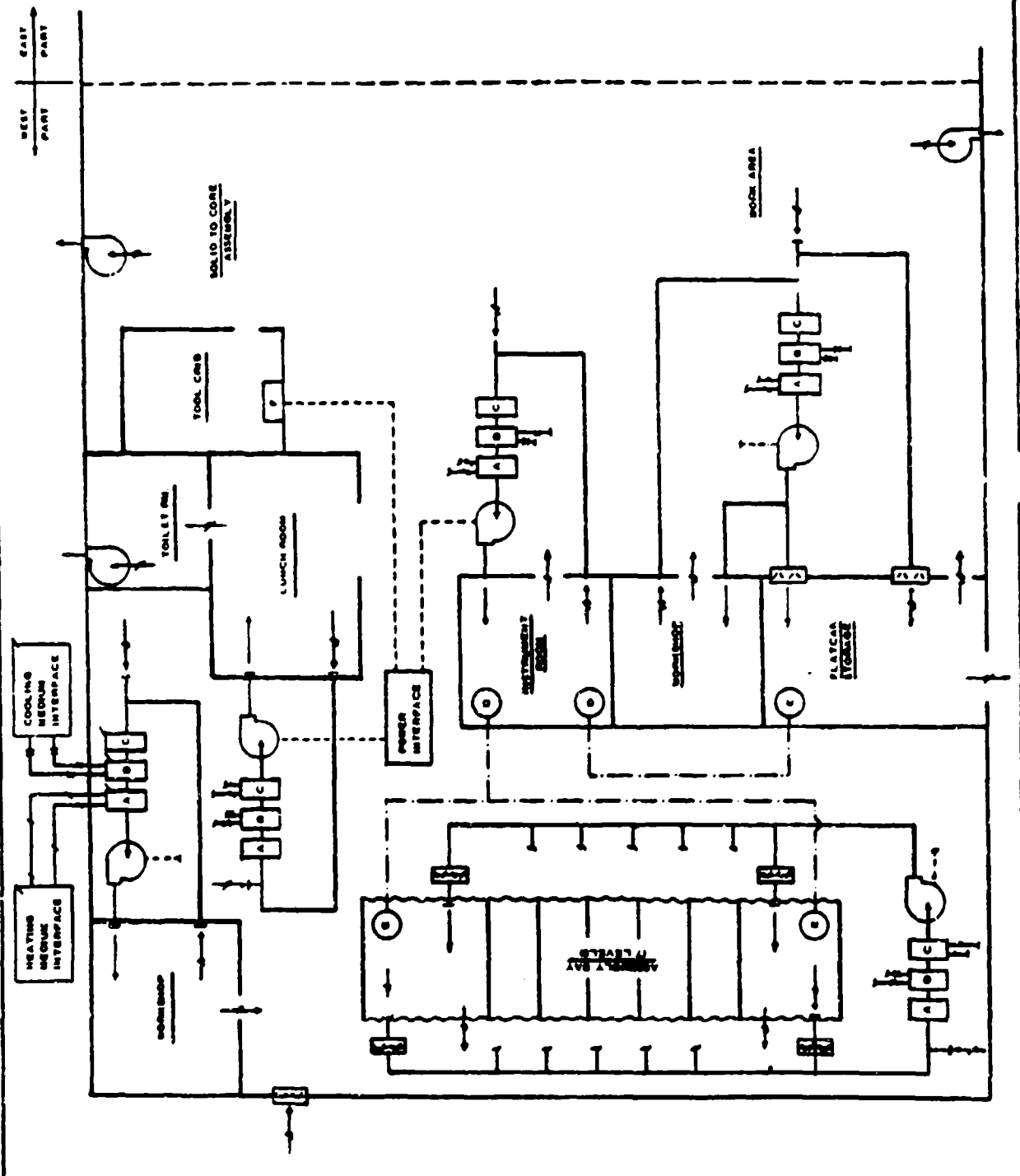

LEGEND

- A [Symbol A]
- B [Symbol B]
- C [Symbol C]
- D [Symbol D]
- E [Symbol E]
- F [Symbol F]

HEATING COIL
 COOLING COIL
 FILTER
 TEMPERATURE & HUMIDITY RECORDER
 TEMPERATURE & HUMIDITY CONTROLLER
 AIR VOLUME DAMPER
 FIRE DAMPER
 ELECTRIC HEATER

NOTE:

EAST PART BUILDING ENVIRONMENTAL CONTROL WILL BE IDENTICAL TO THE WEST PART

SYSTEMS ENGINEER	DATE
DESIGNED BY	DATE
CHECKED BY	DATE
APPROVED BY	DATE
REVISION	DESCRIPTION
1	INITIAL
2	DATE
3	DATE
4	DATE
5	DATE
6	DATE
7	DATE
8	DATE
9	DATE
10	DATE

Figure 40 Schematic Diagram for S1A3 Building Environmental Control

223/224

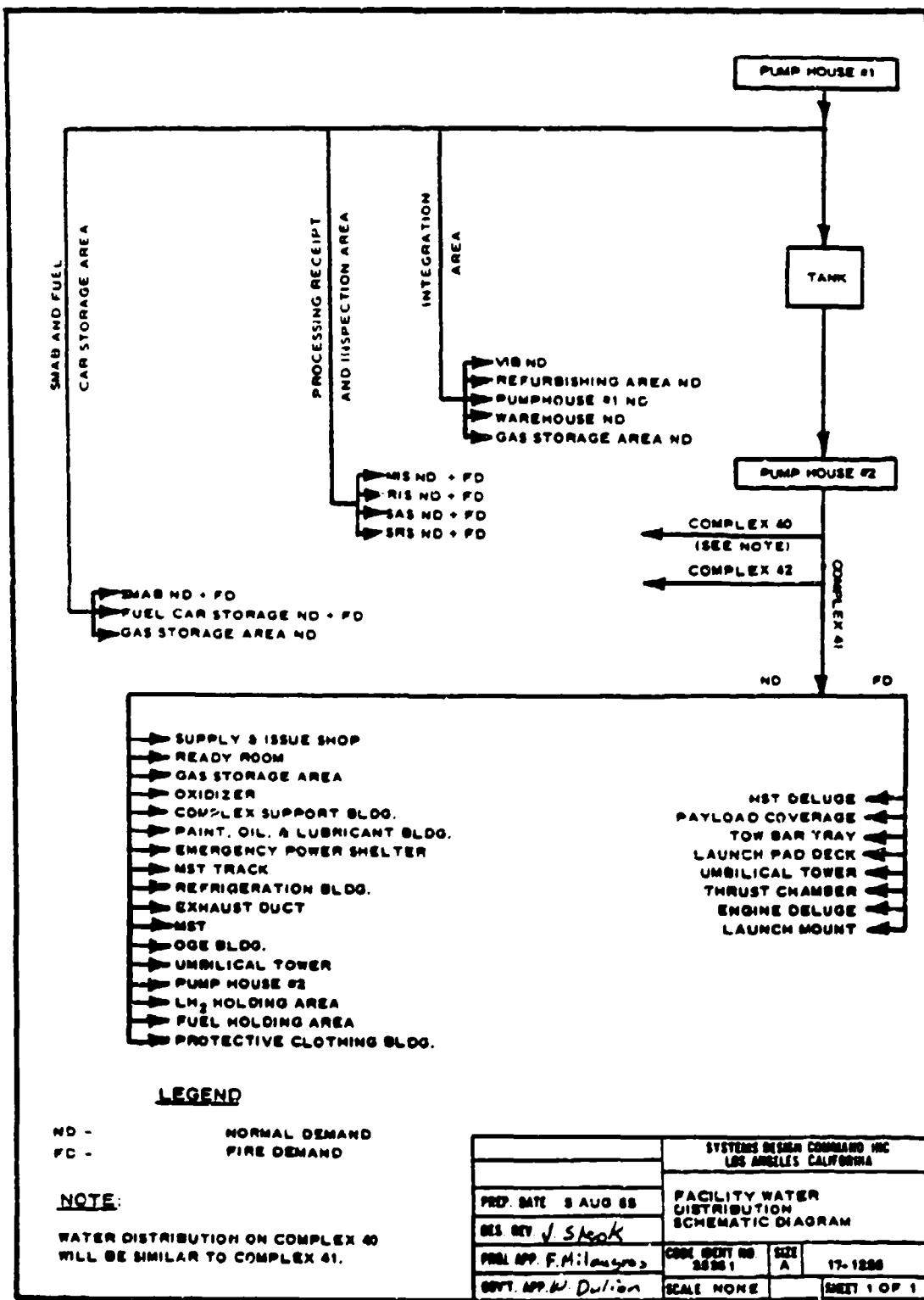

Figure 61. Schematic Diagram for Facilities Water Distribution.

AFSCM 375-5

10 March 1966

17.0 ELECTRONICS SYSTEM SCHEMATIC BLOCK DIAGRAM. Figure 62 is an example of applying schematic diagram methodology to deter-

mine interfaces between control position for 4XXL warning and surveillance system.

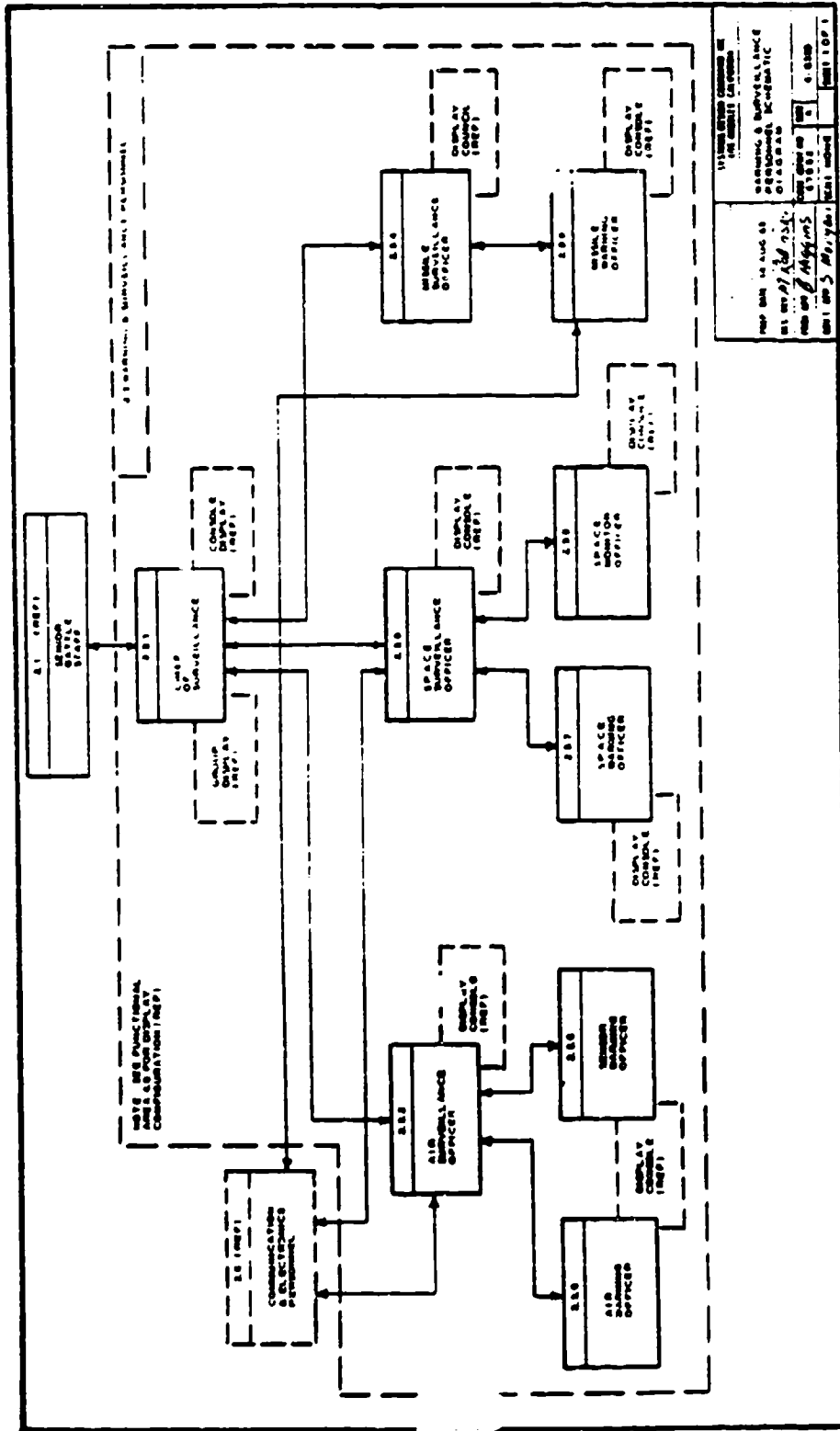
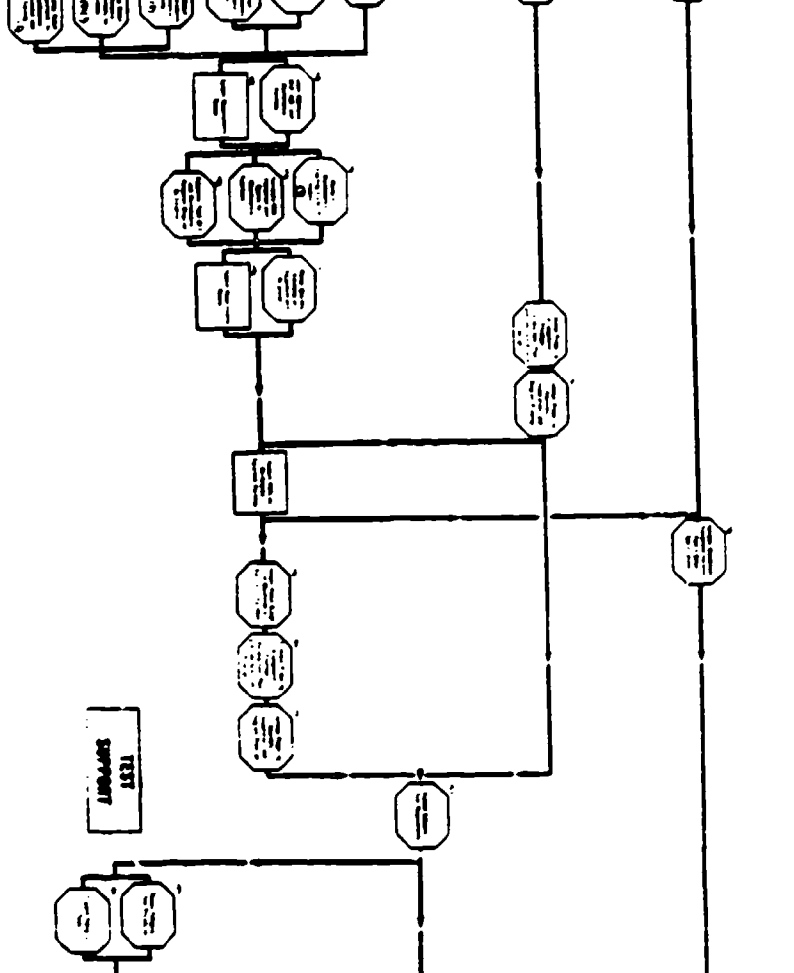

Figure 62. Schematic Diagram (Second Level) of Working and Surveillance Personnel for a 4XXX System.



TEST



TEST

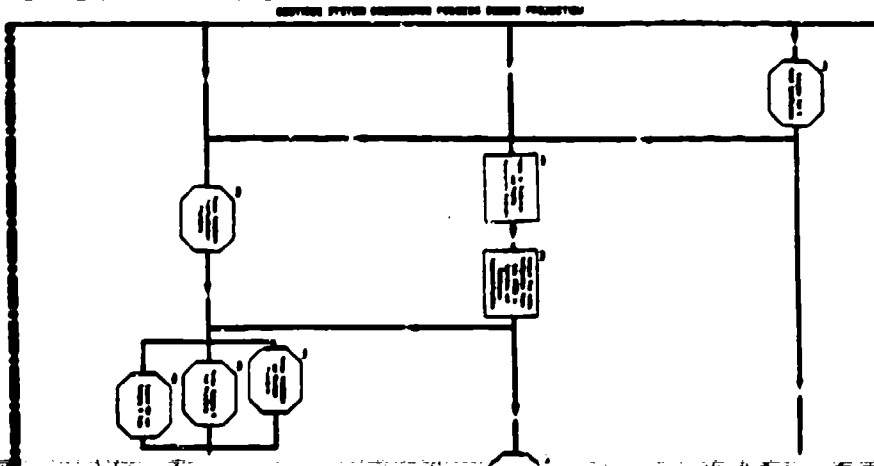
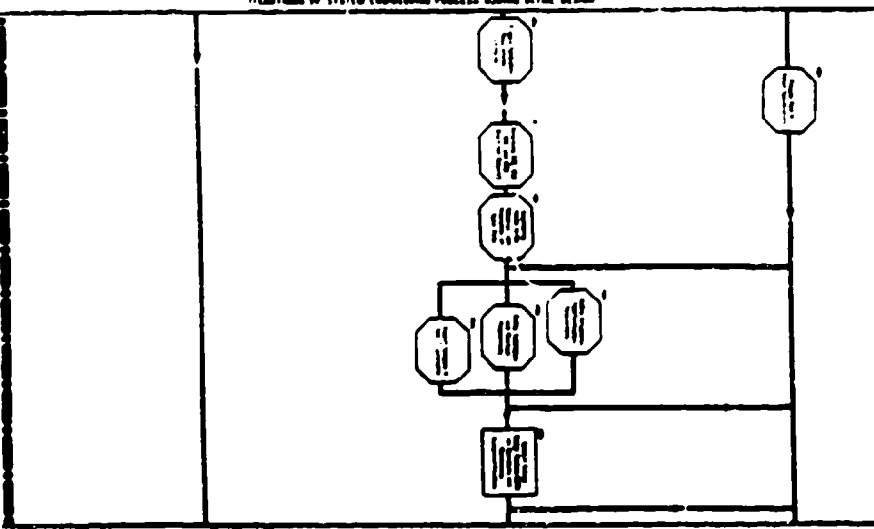

10 March 1968

SYSTEM ENGINEERING MANAGEMENT PROCESS FIG. 5

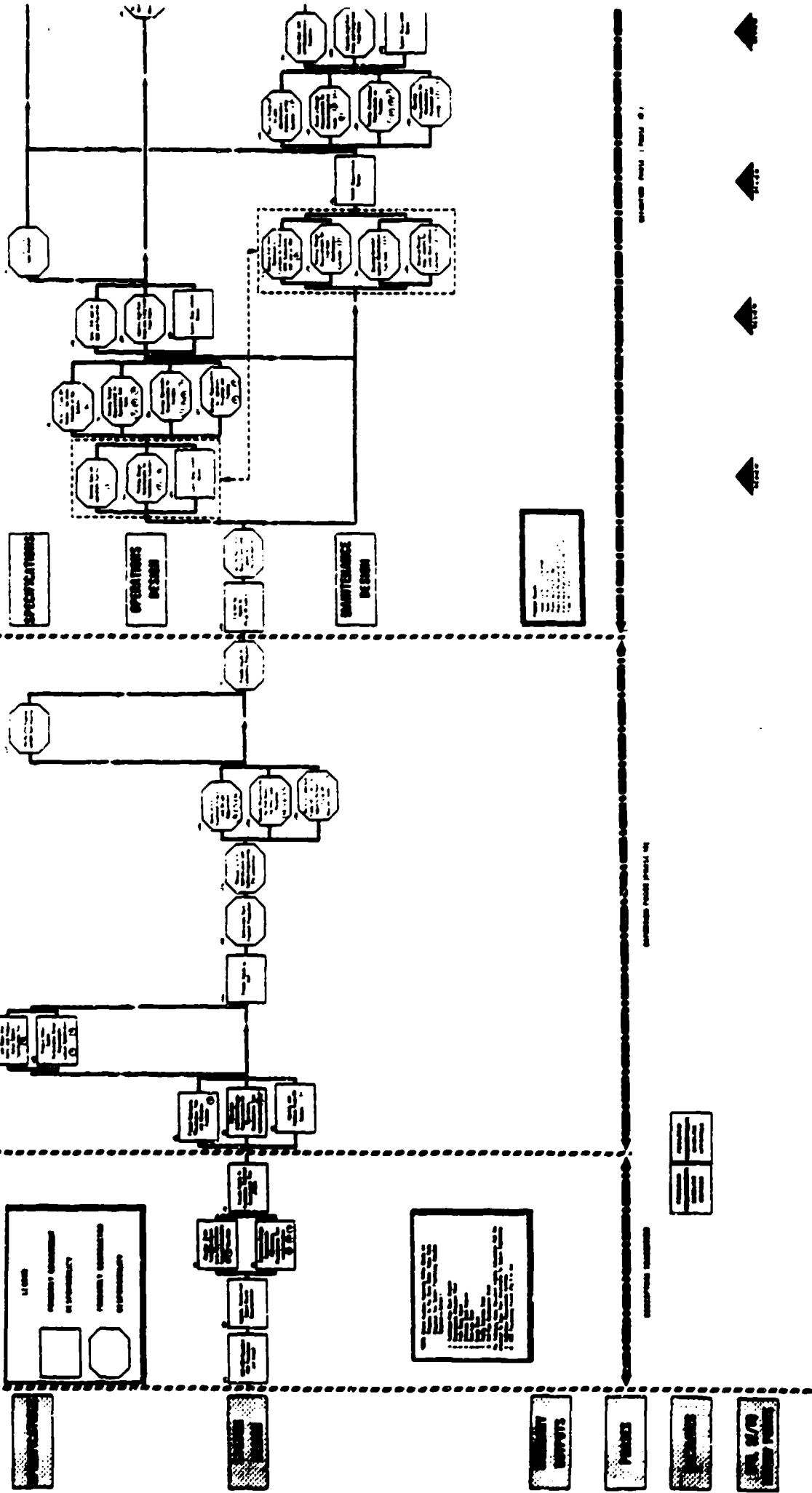

Document Page 1 of 10

Document Page 1 of 10

Document Page 1 of 10



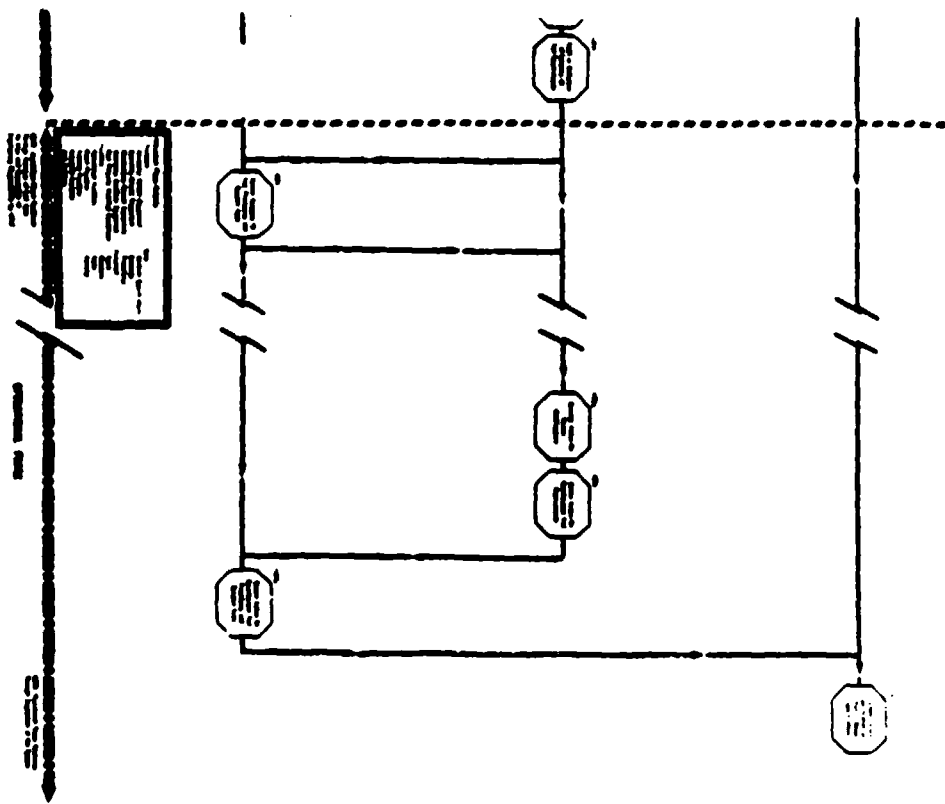

AFSCM 375-5

MISSION ELEMENTS		MAINTENANCE ELEMENTS		
FLIGHT OR PRIME MISSION	MISSION READINESS AND INITIATION	ORGANIZATIONAL LEVEL MAINTENANCE	FIELD LEVEL MAINTENANCE	DEPOT LEVEL MAINTENANCE
MANAGED SPACE SYSTEM	AEROSPACE VEHICLE EQUIPMENT (AVE) PERSONNEL	<p>OPERATING GROUND EQUIP (GGE) FACILITIES PERSONNEL</p> <p>EARTH SPACE</p> <p>↑ EARTH MAINTAINED ONLY</p> <p>↑ SPACE MAINT REQUIRED</p>	<p>ASSEMBLY MAINTENANCE SHOPS</p> <p>MAINTENANCE EQUIPMENT FACILITIES PERSONNEL</p>	<p>SPECIALIZED REPAIR ACTIVITY (SRA)</p> <p>SPECIALIZED REPAIR ACTIVITY (SRA)</p>
	AEROSPACE VEHICLE EQUIPMENT (AVE)	<p>OPERATING GROUND EQUIP (GGE) FACILITIES PERSONNEL</p> <p>EARTH SPACE</p> <p>↑ EARTH MAINTAINED ONLY</p> <p>↑ SPACE MAINT REQUIRED</p>	<p>ASSEMBLY MAINTENANCE SHOPS</p> <p>MAINTENANCE EQUIPMENT FACILITIES PERSONNEL</p>	<p>SPECIALIZED REPAIR ACTIVITY (SRA)</p> <p>SPECIALIZED REPAIR ACTIVITY (SRA)</p>
UNMANAGED SPACE SYSTEM	AEROSPACE VEHICLE EQUIPMENT (AVE)	<p>OPERATING GROUND EQUIP (GGE) FACILITIES PERSONNEL</p> <p>EARTH SPACE</p> <p>↑ EARTH MAINTAINED ONLY</p> <p>↑ SPACE MAINT REQUIRED</p>	<p>ASSEMBLY MAINTENANCE SHOPS</p> <p>MAINTENANCE EQUIPMENT FACILITIES PERSONNEL</p>	<p>SPECIALIZED REPAIR ACTIVITY (SRA)</p> <p>SPECIALIZED REPAIR ACTIVITY (SRA)</p>
	AEROSPACE VEHICLE EQUIPMENT (AVE)	<p>OPERATING GROUND EQUIP (GGE) FACILITIES PERSONNEL</p> <p>EARTH SPACE</p> <p>↑ EARTH MAINTAINED ONLY</p> <p>↑ SPACE MAINT REQUIRED</p>	<p>ASSEMBLY MAINTENANCE SHOPS</p> <p>MAINTENANCE EQUIPMENT FACILITIES PERSONNEL</p>	<p>SPECIALIZED REPAIR ACTIVITY (SRA)</p> <p>SPECIALIZED REPAIR ACTIVITY (SRA)</p>
BALLISTIC MISSILE SYSTEM	AEROSPACE VEHICLE EQUIPMENT (AVE)	<p>OPERATING GROUND EQUIP (GGE) FACILITIES PERSONNEL</p> <p>EARTH SPACE</p> <p>↑ EARTH MAINTAINED ONLY</p> <p>↑ SPACE MAINT REQUIRED</p>	<p>ASSEMBLY MAINTENANCE SHOPS</p> <p>MAINTENANCE EQUIPMENT FACILITIES PERSONNEL</p>	<p>SPECIALIZED REPAIR ACTIVITY (SRA)</p> <p>SPECIALIZED REPAIR ACTIVITY (SRA)</p>
	AEROSPACE VEHICLE EQUIPMENT (AVE)	<p>OPERATING GROUND EQUIP (GGE) FACILITIES PERSONNEL</p> <p>EARTH SPACE</p> <p>↑ EARTH MAINTAINED ONLY</p> <p>↑ SPACE MAINT REQUIRED</p>	<p>ASSEMBLY MAINTENANCE SHOPS</p> <p>MAINTENANCE EQUIPMENT FACILITIES PERSONNEL</p>	<p>SPECIALIZED REPAIR ACTIVITY (SRA)</p> <p>SPECIALIZED REPAIR ACTIVITY (SRA)</p>
MANAGED AIRCRAFT SYSTEM	AEROSPACE VEHICLE EQUIPMENT (AVE) PERSONNEL	<p>AEROSPACE MAINT GROUND EQUIP (MGE) FACILITIES PERSONNEL</p>	<p>FLIGHT LINE MAINTENANCE</p>	<p>SPECIALIZED REPAIR ACTIVITY (SRA)</p> <p>SPECIALIZED REPAIR ACTIVITY (SRA)</p>
	AEROSPACE VEHICLE EQUIPMENT (AVE) PERSONNEL	<p>AEROSPACE MAINT GROUND EQUIP (MGE) FACILITIES PERSONNEL</p>	<p>FLIGHT LINE MAINTENANCE</p>	<p>SPECIALIZED REPAIR ACTIVITY (SRA)</p> <p>SPECIALIZED REPAIR ACTIVITY (SRA)</p>
ELECTRONIC SYSTEM	PRIME MISSION GROUND OPERATING EQUIP PERSONNEL (GEP) FACILITIES PERSONNEL COMPUTER PROGRAM	<p>AEROSPACE MAINT GROUND EQUIP (MGE) FACILITIES PERSONNEL</p> <p>↑ EARTH MAINTAINED ONLY</p> <p>↑ SPACE MAINT REQUIRED</p>	<p>IN SYSTEM CHECK</p>	<p>SPECIALIZED REPAIR ACTIVITY (SRA)</p> <p>SPECIALIZED REPAIR ACTIVITY (SRA)</p>
	PRIME MISSION GROUND OPERATING EQUIP PERSONNEL (GEP) FACILITIES PERSONNEL COMPUTER PROGRAM	<p>AEROSPACE MAINT GROUND EQUIP (MGE) FACILITIES PERSONNEL</p> <p>↑ EARTH MAINTAINED ONLY</p> <p>↑ SPACE MAINT REQUIRED</p>	<p>IN SYSTEM CHECK</p>	<p>SPECIALIZED REPAIR ACTIVITY (SRA)</p> <p>SPECIALIZED REPAIR ACTIVITY (SRA)</p>

COMPUTER PROGRAM MAINTAINED

TYPICAL SYSTEM PROGRAMS

10 March 1966

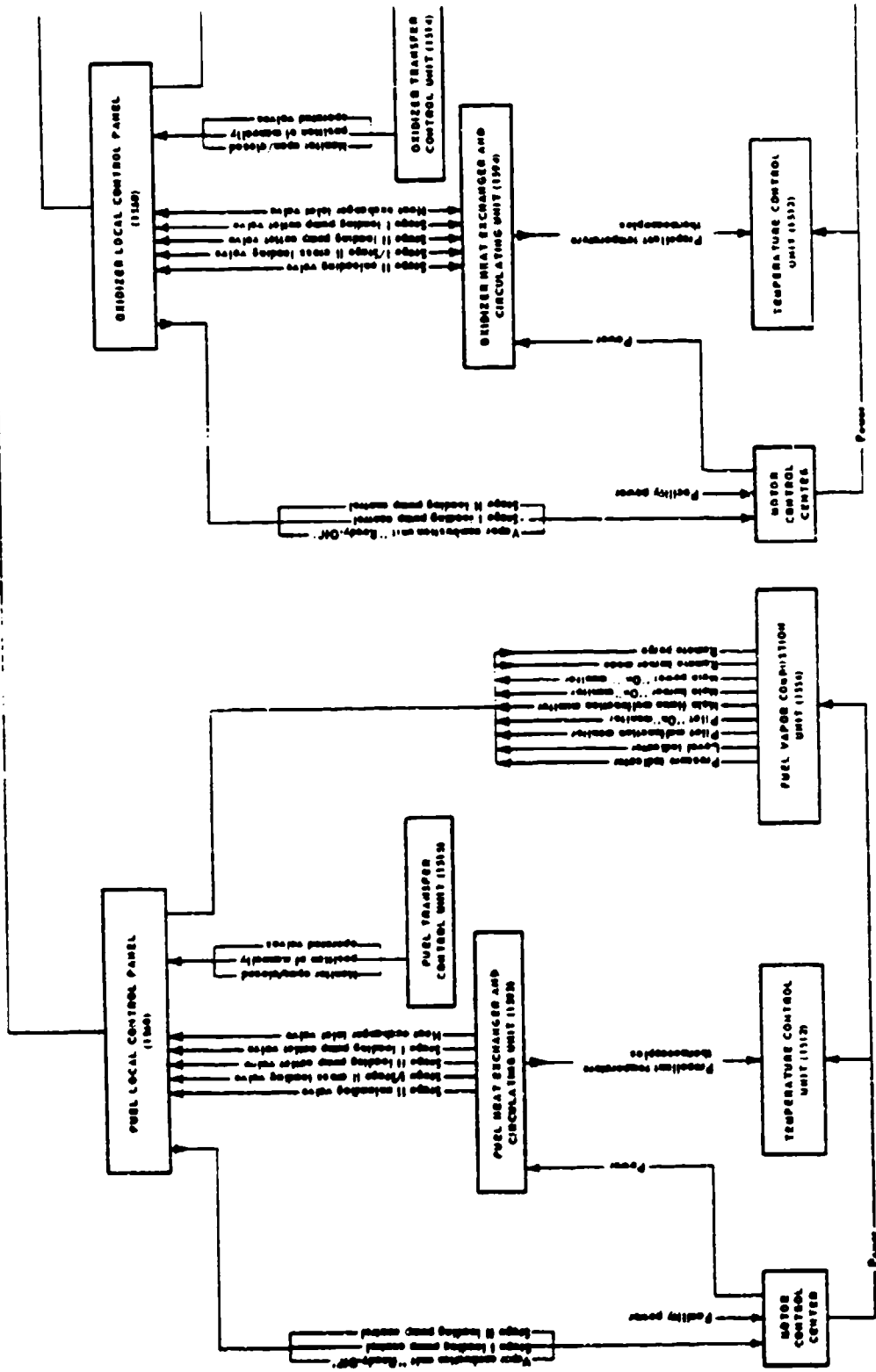

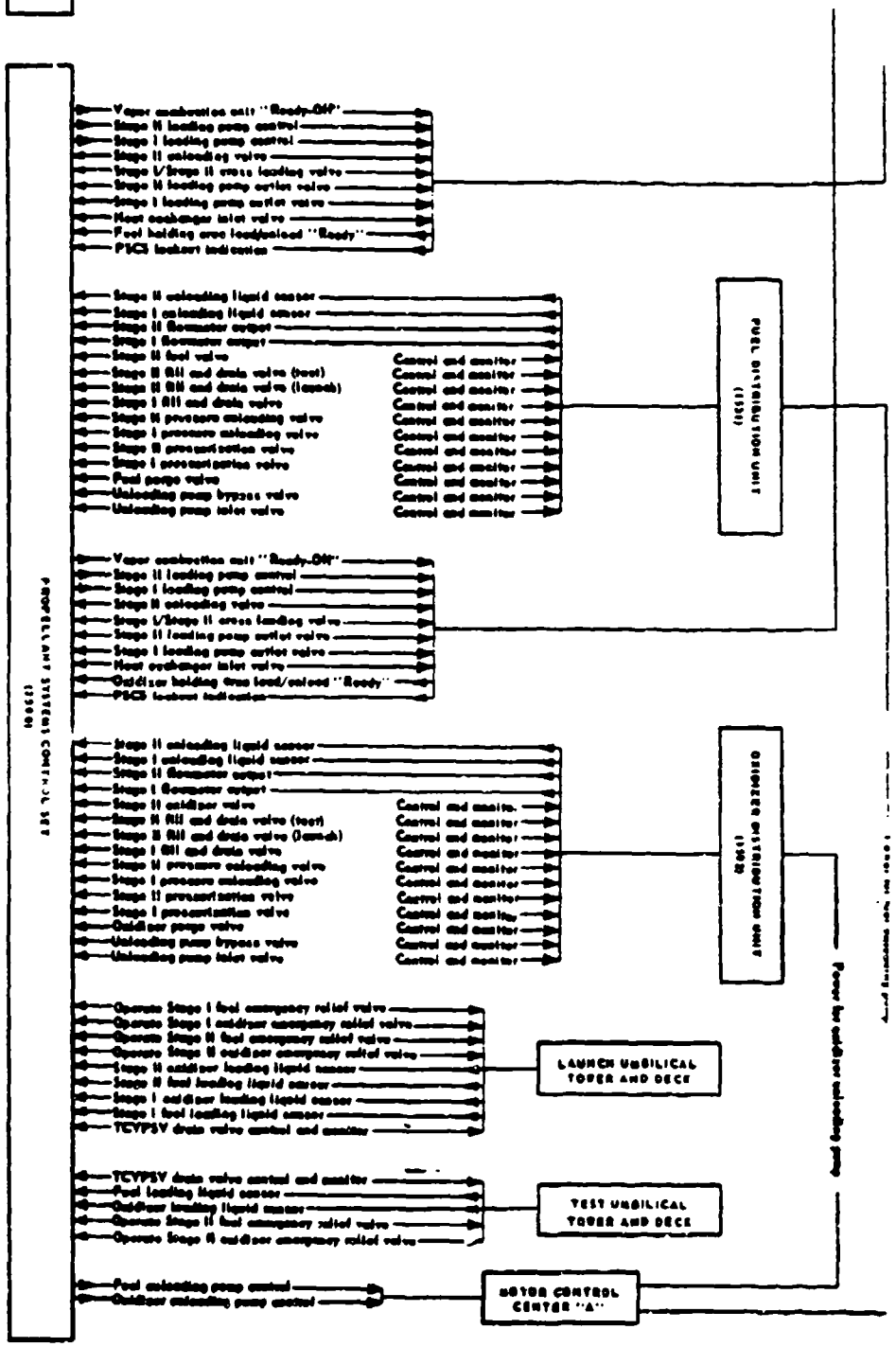

PROPULSION SYSTEM CONTROL SET	11304
DATE	11/10/88
BY	W. J. ...
CHKD BY	...
APP'D BY	...
REV.	...
NO.	...
DATE	...
BY	...
CHKD BY	...
APP'D BY	...
REV.	...
NO.	...
DATE	...
BY	...
CHKD BY	...
APP'D BY	...
REV.	...
NO.	...
DATE	...
BY	...
CHKD BY	...
APP'D BY	...
REV.	...
NO.	...
DATE	...
BY	...
CHKD BY	...
APP'D BY	...

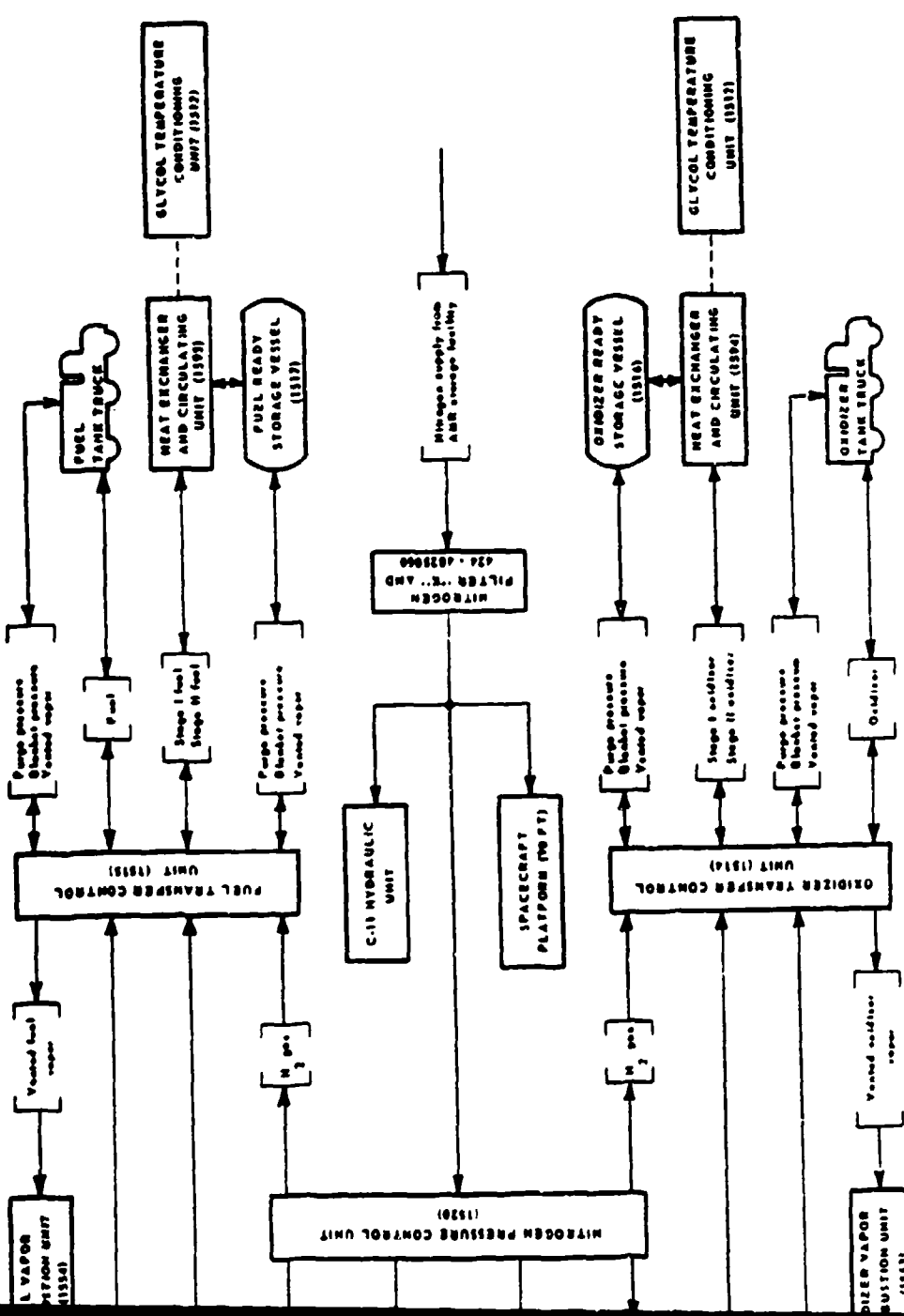

SYSTEMS ENGINEERING DEPARTMENT		100 MILITARY CAMPUS	
PROPELLANT TRANSFER & PRESSURIZATION SUBSYSTEM SCHEMATIC BLOCK DIAGRAM			
REP. NO.	10 APR 68	REV.	0
DES. BY	D. J. McQuinn	CHKD. BY	J. M. Quinn
APP. BY	J. M. Quinn	DATE	10 APR 68
CONT. BY	J. M. Quinn	CONT. NO.	103000
			SHEET 1 OF 1

Transfer and Pressurization Subsystem

Attachment 2

10 March 1966

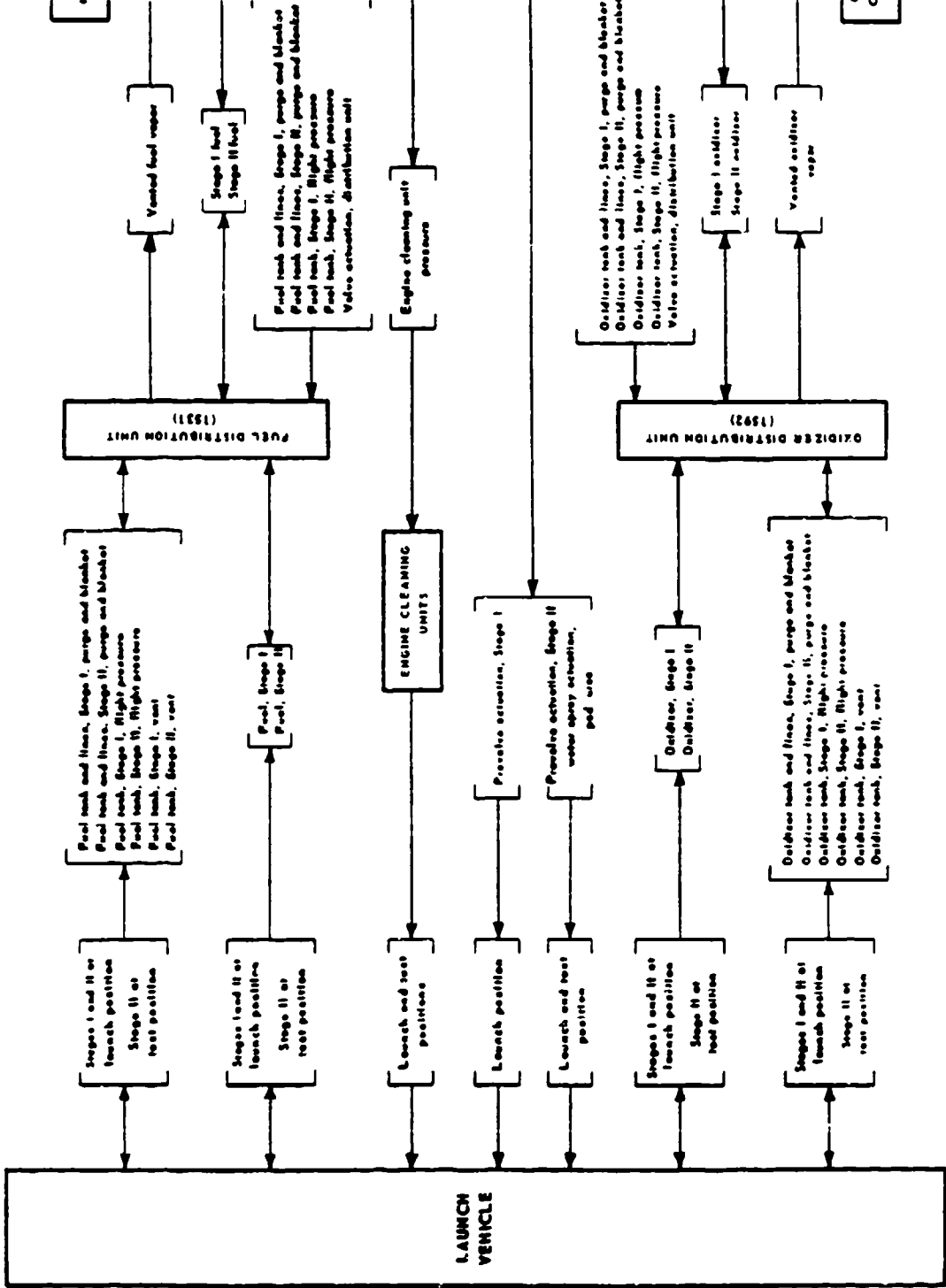

Figure 45 - Schematic Diagram of