

PHOTOGRAPH THIS SHEET

AD A 951 939

DTIC ACCESSION NUMBER

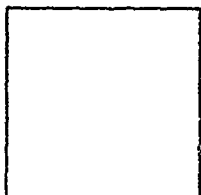

LEVEL

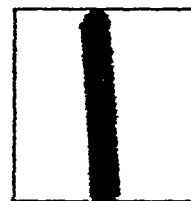

INVENTORY

The TPRC Data Series, Volume 5

DOCUMENT IDENTIFICATION

1970

DISTRIBUTION STATEMENT A

Approved for public release;
Distribution Unlimited

DISTRIBUTION STATEMENT

ACCESSION FOR	
NTIS	GRA&I <input checked="" type="checkbox"/>
DTIC	TAB <input type="checkbox"/>
UNANNOUNCED	<input type="checkbox"/>
JUSTIFICATION	
(1970)	
BY	
DISTRIBUTION /	
AVAILABILITY CODES	
DIST	AVAIL AND/OR SPECIAL
A	21

DISTRIBUTION STAMP

DTIC
ELECTE
S JUN 9 1983 D
D

DATE ACCESSIONED



UNANNOUNCED

83 05 18 006

DATE RECEIVED IN DTIC

PHOTOGRAPH THIS SHEET AND RETURN TO DTIC-DDA-2

THERMOPHYSICAL PROPERTIES OF MATTER

The TPRC Data Series

VOLUME 5

7009¹¹

SPECIFIC HEAT

Nonmetallic Solids

A951939

DISTRIBUTION STATEMENT A

Approved for public release;
Distribution Unlimited

PROPERTY OF
THERMOPHYSICAL PROPERTIES RESEARCH CENTER

SPECIFIC HEAT

Nonmetallic Solids

THERMOPHYSICAL PROPERTIES OF MATTER
The TPRC Data Series

A Comprehensive Compilation of Data by the
Thermophysical Properties Research Center (TPRC), Purdue University

Y. S. Touloukian, Series Editor
C. Y. Ho, Series Technical Editor

- Volume 1. Thermal Conductivity—Metallic Elements and Alloys
- Volume 2. Thermal Conductivity—Nonmetallic Solids
- Volume 3. Thermal Conductivity—Nonmetallic Liquids and Gases
- Volume 4. Specific Heat—Metallic Elements and Alloys
- Volume 5. Specific Heat—Nonmetallic Solids
- Volume 6. Specific Heat—Nonmetallic Liquids and Gases
- Volume 7. Thermal Radiative Properties—Metallic Elements and Alloys
- Volume 8. Thermal Radiative Properties—Nonmetallic Solids
- Volume 9. Thermal Radiative Properties—Coatings
- Volume 10. Thermal Diffusivity
- Volume 11. Viscosity
- Volume 12. Thermal Expansion—Metallic Elements and Alloys
- Volume 13. Thermal Expansion—Nonmetallic Solids

New data on thermophysical properties are being constantly accumulated at TPRC. Contact TPRC and use its interim updating services for the most current information

THERMOPHYSICAL PROPERTIES OF MATTER
VOLUME 5

SPECIFIC HEAT

Nonmetallic Solids

Y. S. Touloukian

Director
Thermophysical Properties Research Center
and
Distinguished Atkins Professor of Engineering
School of Mechanical Engineering
Purdue University
and
Visiting Professor of Mechanical Engineering
Auburn University

E. H. Buyco

Assistant Professor of Engineering
Purdue University
Calumet Campus
Formerly
Assistant Senior Researcher
Thermophysical Properties Research Center
Purdue University

IFI/PLENUM • NEW YORK-WASHINGTON • 1970

Library of Congress Catalog Card Number 73-129616

SBN (13-Volume Set) 306-67020-8

SBN (Volume 5) 306-67025-9

Copyright © 1970, Purdue Research Foundation

IFI/Plenum Data Corporation is a subsidiary of
Plenum Publishing Corporation
227 West 17th Street, New York, N.Y. 10011

Distributed in Europe by Heyden & Son, Ltd.
Spectrum House, Alderton Crescent
London N.W. 4, England

Printed in the United States of America

"In this work, when it shall be found that much is omitted, let it not be forgotten that much likewise is performed..."

SAMUEL JOHNSON, A.M.

From last paragraph of Preface to his two-volume *Dictionary of the English Language*, Vol. I, page 5, 1755, London, Printed by Strahan.

Foreword

In 1957, the Thermophysical Properties Research Center (TPRC) of Purdue University, under the leadership of its founder, Professor Y. S. Touloukian, began to develop a coordinated experimental, theoretical, and literature review program covering a set of properties of great importance to science and technology. Over the years, this program has grown steadily, producing bibliographies, data compilations and recommendations, experimental measurements, and other output. The series of volumes for which these remarks constitute a foreword is one of these many important products. These volumes are a monumental accomplishment in themselves, requiring for their production the combined knowledge and skills of dozens of dedicated specialists. The Thermophysical Properties Research Center deserves the gratitude of every scientist and engineer who uses these compiled data.

The individual nontechnical citizen of the United States has a stake in this work also, for much of the science and technology that contributes to his well-being relies on the use of these data. Indeed, recognition of this importance is indicated by a mere reading of the list of the financial sponsors of the Thermophysical Properties Research Center; leaders of the technical industry of the United States and agencies of the Federal Government are well represented.

Experimental measurements made in a laboratory have many potential applications. They might be used, for example, to check a theory, or to help design a chemical manufacturing plant, or to compute the characteristics of a heat exchanger in a nuclear power plant. The progress of science and technology demands that results be published in the open literature so that others may use them. Fortunately for progress, the useful data in any single field are not scattered throughout the tens of thousands of technical journals published throughout the world. In most fields, fifty percent of the useful work appears in no more than thirty or forty journals. However, in the case of TPRC, its field is so broad

that about 100 journals are required to yield fifty percent. But that other fifty percent! It is scattered through more than 3500 journals and other documents, often items not readily identifiable or obtainable. Nearly 50,000 references are now in the files.

Thus, the man who wants to use existing data, rather than make new measurements himself, faces a long and costly task if he wants to assure himself that he has found all the relevant results. More often than not, a search for data stops after one or two results are found—or after the searcher decides he has spent enough time looking. Now with the appearance of these volumes, the scientist or engineer who needs these kinds of data can consider himself very fortunate. He has a single source to turn to; thousands of hours of search time will be saved, innumerable repetitions of measurements will be avoided, and several billions of dollars of investment in research work will have been preserved.

However, the task is not ended with the generation of these volumes. A critical evaluation of much of the data is still needed. Why are discrepant results obtained by different experimentalists? What undetected sources of systematic error may affect some or even all measurements? What value can be derived as a "recommended" figure from the various conflicting values that may be reported? These questions are difficult to answer, requiring the most sophisticated judgment of a specialist in the field. While a number of the volumes in this Series do contain critically evaluated and recommended data, these are still in the minority. The data are now being more intensively evaluated by the staff of TPRC as an integral part of the effort of the National Standard Reference Data System (NSRDS). The task of the National Standard Reference Data System is to organize and operate a comprehensive program to prepare compilations of critically evaluated data on the properties of substances. The NSRDS is administered by the National Bureau of Standards under a directive from the Federal Council for Science

and Technology, augmented by special legislation of the Congress of the United States. TPRC is one of the national resources participating in the National Standard Reference Data System in a united effort to satisfy the needs of the technical community for readily accessible, critically evaluated data.

As a representative of the NBS Office of Standard Reference Data, I want to congratulate Professor Touloukian and his colleagues on the accomplishments represented by this Series of reference data

books. Scientists and engineers the world over are indebted to them. The task ahead is still an awesome one and I urge the nation's private industries and all concerned Federal agencies to participate in fulfilling this national need of assuring the availability of standard numerical reference data for science and technology.

EDWARD L. BRADY
Associate Director for Information Programs
National Bureau of Standards

Preface

Thermophysical Properties of Matter, the TPRC Data Series, is the culmination of twelve years of pioneering effort in the generation of tables of numerical data for science and technology. It constitutes the restructuring, accompanied by extensive revision and expansion of coverage, of the original *TPRC Data Book*, first released in 1960 in loose-leaf format, 11" x 17" in size, and issued in June and December annually in the form of supplements. The original loose-leaf *Data Book* was organized in three volumes: (1) metallic elements and alloys, (2) nonmetallic elements, compounds, and mixtures which are solid at N.T.P., and (3) nonmetallic elements, compounds, and mixtures which are liquid or gaseous at N.T.P. Within each volume, each property constituted a chapter.

Because of the vast proportions the *Data Book* began to assume over the years of its growth and the greatly increased effort necessary in its maintenance by the user, it was decided in 1967 to change from the loose-leaf format to a conventional publication. Thus, the December 1966 supplement of the original *Data Book* was the last supplement disseminated by TPRC.

While the manifold physical, logistic, and economic advantages of the bound volume over the loose-leaf oversize format are obvious and welcome to all who have used the unwieldy original volumes, the assumption that this work will no longer be kept on a current basis because of its bound format would not be correct. Fully recognizing the need of many important research and development programs which require the latest available information, TPRC has instituted a *Data Update Plan* enabling the subscriber to inquire, by telephone if necessary, for specific information and receive, in many instances, same-day response on any new data processed or revision of published data since the latest edition. In this context, the TPRC Data Series departs drastically from the conventional handbook and giant multivolume classical works, which are no longer adequate media for the dissemination of

numerical data of science and technology without a continuing activity on contemporary coverage. The loose-leaf arrangements of many works fully recognize this fact and attempt to develop a combination of bound volumes and loose-leaf supplement arrangements as the work becomes increasingly large. TPRC's *Data Update Plan* is indeed unique in this sense since it maintains the contents of the TPRC Data Series current and live on a day-to-day basis between editions. In this spirit, I strongly urge all purchasers of these volumes to complete in detail and return the *Volume Registration Certificate* which accompanies each volume in order to assure themselves of the continuous receipt of annual listing of corrigenda during the life of the edition.

The TPRC Data Series consists initially of 13 independent volumes. The initial ten volumes will be published in 1970, and the remaining three by 1972. It is also contemplated that subsequent to the first edition, each volume will be revised, updated, and reissued in a new edition approximately every fifth year. The organization of the TPRC Data Series makes each volume a self-contained entity available individually without the need to purchase the entire Series.

The coverage of the specific thermophysical properties represented by this Series constitutes the most comprehensive and authoritative collection of numerical data of its kind for science and technology.

Whenever possible, a uniform format has been used in all volumes, except when variations in presentation were necessitated by the nature of the property or the physical state concerned. In spite of the wealth of data reported in these volumes, it should be recognized that all volumes are not of the same degree of completeness. However, as additional data are processed at TPRC on a continuing basis, subsequent editions will become increasingly more complete and up to date. Each volume in the Series basically comprises three sections, consisting of a text, the body of numerical data with source references, and a material index.

The aim of the textual material is to provide a complementary or supporting role to the body of numerical data rather than to present a treatise on the subject of the property. The user will find a basic theoretical treatment, a comprehensive presentation of selected works which constitute reviews, or compendia of empirical relations useful in estimation of the property when there exists a paucity of data or when data are completely lacking. Established major experimental techniques are also briefly reviewed.

The body of data is the core of each volume and is presented in both graphical and tabular format for convenience of the user. Every single point of numerical data is fully referenced as to its original source and no secondary sources of information are used in data extraction. In general, it has not been possible to critically scrutinize all the original data presented in these volumes, except to eliminate perpetuation of gross errors. However, in a significant number of cases, such as for the properties of liquids and gases and the thermal conductivity of all the elements, the task of full evaluation, synthesis, and correlation has been completed. It is hoped that in subsequent editions of this continuing work, not only new information will be reported but the critical evaluation will be extended to increasingly broader classes of materials and properties.

The third and final major section of each volume is the material index. This is the key to the volume, enabling the user to exercise full freedom of access to its contents by any choice of substance name or detailed alloy and mixture composition, trade name, synonym, etc. Of particular interest here is the fact that in the case of those properties which are reported in separate companion volumes, the material index in each of the volumes also reports the contents of the other companion volumes.* The sets of companion volumes are as follows:

Thermal conductivity:	Volumes 1, 2, 3
Specific heat:	Volumes 4, 5, 6
Radiative properties:	Volumes 7, 8, 9
Thermal expansion:	Volumes 12, 13

The ultimate aims and functions of TPRC's Data Tables Division are to extract, evaluate, reconcile, correlate, and synthesize all available data for the thermophysical properties of materials with

*For the first edition of the Series, this arrangement was not feasible for Volume 7 due to the sequence and the schedule of its publication. This situation will be resolved in subsequent editions.

the result of obtaining internally consistent sets of property values, termed the "recommended reference values." In such work, gaps in the data often occur, for ranges of temperature, composition, etc. Whenever feasible, various techniques are used to fill in such missing information, ranging from empirical procedures to detailed theoretical calculations. Such studies are resulting in valuable new estimation methods being developed which have made it possible to estimate values for substances and/or physical conditions presently unmeasured or not amenable to laboratory investigation. Depending on the available information for a particular property and substance, the end product may vary from simple tabulations of isolated values to detailed tabulations with generating equations, plots showing the concordance of the different values, and, in some cases, over a range of parameters presently unexplored in the laboratory.

The TPRC Data Series constitutes a permanent and valuable contribution to science and technology. These constantly growing volumes are invaluable sources of data to engineers and scientists, sources in which a wealth of information heretofore unknown or not readily available has been made accessible. We look forward to continued improvement of both format and contents so that TPRC may serve the scientific and technological community with ever-increasing excellence in the years to come. In this connection, the staff of TPRC is most anxious to receive comments, suggestions, and criticisms from all users of these volumes. An increasing number of colleagues are making available at the earliest possible moment reprints of their papers and reports as well as pertinent information on the more obscure publications. I wish to renew my earnest request that this procedure become a universal practice since it will prove to be most helpful in making TPRC's continuing effort more complete and up to date.

It is indeed a pleasure to acknowledge with gratitude the multisource financial assistance received from over fifty of TPRC's sponsors which has made the continued generation of these tables possible. In particular, I wish to single out the sustained major support being received from the Air Force Materials Laboratory-Air Force Systems Command, the Office of Standard Reference Data-National Bureau of Standards, and the Office of Advanced Research and Technology-National Aeronautics and Space Administration. TPRC is indeed proud to have been designated as a National Information Analysis Center for the Department of Defense as well as a component of the National

Standard Reference Data System under the cognizance of the National Bureau of Standards.

While the preparation and continued maintenance of this work is the responsibility of TPRC's Data Tables Division, it would not have been possible without the direct input of TPRC's Scientific Documentation Division and, to a lesser degree, the Theoretical and Experimental Research Divisions. The authors of the various volumes are the senior staff members in responsible charge of the work. It should be clearly understood, however, that many have contributed over the years and their contributions are specifically acknowledged in each volume. I wish to take this opportunity to personally

thank those members of the staff, research assistants, graduate research assistants, and supporting graphics and technical typing personnel without whose diligent and painstaking efforts this work could not have materialized.

Y. S. TOULOUKIAN

Director

*Thermophysical Properties Research Center
Distinguished Atkins Professor of Engineering*

Purdue University
Lafayette, Indiana
July 1969

Introduction to Volume 5

This volume of *Thermophysical Properties of Matter*, the TPRC Data Series, was initiated in recent years and follows the general format of the Center's work on thermal conductivity.

The volume comprises three major sections: the front text material together with its bibliography, the main body of numerical data and its references, and the material index.

The text material is intended to assume a role complementary to the main body of numerical data, the presentation of which is the primary purpose of this volume. It is felt that a concise discussion of the theoretical nature of the property under consideration together with a review of predictive procedures and recognized experimental techniques will be appropriate in a major reference work of this kind. The extensive reference citations given in the text should lead the interested reader to a highly comprehensive literature for a detailed study. It is hoped, however, that enough detail is presented for this volume to be self-contained for the practical user.

The main body of the volume consists of the presentation of numerical data compiled over the years in a most comprehensive and meticulous manner. The scope of coverage includes most non-metallic materials of engineering importance which are in the solid state at normal temperature and pressure. The extraction of all data directly from their original sources ensures freedom from errors of transcription. Furthermore, some gross errors appearing in the original source documents have been corrected. The organization and presentation of the data together with other pertinent information in the use of the tables and figures are discussed in detail in the text of the section entitled *Numerical Data*.

It is regrettable that the authors have not yet had the time to review and evaluate critically the extensive data compiled in this volume. However, it is hoped that the user will be able to exercise proper selectivity and discretion among conflicting sets of data based on the extensive information reported for each set in the accompanying specification tables.

As stated earlier, all data have been obtained from their original sources and each data set is so referenced. TPRC has in its files all documents cited in this volume. Those that cannot be readily obtained elsewhere are available from TPRC in microfiche form.

The material index at the end of this volume covers the contents of all three companion volumes (Volumes 4, 5, and 6) on specific heat. It is hoped that the user will find these comprehensive indices helpful.

This work has grown out of activities made possible principally through the support of the Air Force Materials Laboratory—Air Force Systems Command, under the monitorship of Mr. John H. Charlesworth. In the preparation of this volume we have drawn most heavily upon the scientific literature and hence we feel a debt of gratitude to the authors of the referenced articles.

While this volume is primarily intended as a reference work for the designer, researcher, experimentalist, and theoretician, the teacher at the graduate level may also use it as a teaching tool to point out to his students the topography of the state of knowledge on the specific heat of nonmetals. We believe there is also much food for reflection by the specialist and the academician concerning the meaning of "original" investigation and its "information content."

The authors are keenly aware of the possibility of many weaknesses in a work of this scope. We hope that we will not be judged too harshly and that we will receive suggestions regarding references omitted, additional material groups needing more detailed treatment, improvements in presentation, and, most important, any inadvertent errors. If the *Volume Registration Certificate* accompanying this volume is returned, the reader will assure himself of receiving annually a list of corrigenda as possible errors come to our attention.

Lafayette, Indiana
July 1969

Y. S. TOULOUKIAN
E. H. BUYCO

Contents

Foreword	vii
Preface	ix
Introduction to Volume 5	xiii
Grouping of Materials and List of Figures and Tables	xvii

Theory, Estimation, and Measurement

<i>Notation</i>	1a
<i>Theory of Specific Heat of Solids</i>	3a
1. Introduction	3a
2. Definitions	3a
3. Dulong and Petit's Law	4a
4. Einstein's Specific Heat Theory	4a
5. Debye's Specific Heat Theory	5a
6. Electronic Specific Heat	6a
7. Magnetic Specific Heat	7a
8. Low-Temperature Specific Heat	8a
9. Normal and Superconducting Materials	8a
<i>Other Major Sources of Data</i>	9a
<i>Methods for the Measurement of the Specific Heat of Solids</i>	11a
1. Introduction	11a
2. Nernst-Type Adiabatic Vacuum Calorimeter	11a
3. Modified Adiabatic Calorimeter	11a
4. Drop Ice Calorimeter	12a
5. Drop Isothermal Water Calorimeter	13a
6. Drop Copper Block Calorimeter	14a
7. Pulse-Heating Method	14a
8. Comparative Method	15a
<i>References to Text</i>	17a

Numerical Data

<i>Data Presentation and Related General Information</i>	19a
1. Scope of Coverage	19a
2. Presentation of Data	19a
3. Symbols and Abbreviations used in the Figures and Tables	19a
4. Conversion Factors for Units of Specific Heat	21a
5. Classification of Materials	21a
6. Convention for Bibliographic Citation	21a
7. Crystal Structures, Transition Temperatures, and Other Pertinent Physical Constants of the Elements	22a

Numerical Data on Specific Heat of Nonmetallic Solids (See pp. xvii to xxx for detailed listing of entries for each of the following groups of materials)

1. Elements	1
2. Oxides	21
3. Antimonides	297
4. Arsenides	307
5. Beryllides	313
6. Borides	335
7. Carbides	395
8. Germanides	481
9. Iodides	485
10. Phosphides	517
11. Selenides	527
12. Silicides	559
13. Sulfides	635
14. Tellurides	717
15. Bromides	759
16. Chlorides	785
17. Fluorides	915
18. Hydrides	1033
19. Nitrides	1075
20. Carbonates	1109
21. Nitrates and Nitrites	1139
22. Sulfates	1161
23. Glasses and Cermets	1227
24. Oxygen Compounds	1289
<i>References to Data Sources</i>	1639

Material Index

<i>Material Index to Specific Heat Companion Volumes 4, 5, and 6</i>	A1
--	----

GROUPING OF MATERIALS AND LIST OF FIGURES AND TABLES

1. ELEMENTS

Figure and/or Table No.	Name	Symbol	Page No.
1	Boron	B	1
2A	Carbon (Diamond)	C	4
2B	Carbon (Graphite)	C	9
3	Iodine	I	15
4	Phosphorous	P	18
5	Sulfur	S	21

2. OXIDES

		Formula	
6	Aluminum Oxide	Al_2O_3	25
7	Diantimony Tetraoxide	Sb_2O_4	30
8	Diantimony Pentaoxide	Sb_2O_5	33
9	Arsenic Sesquioxide	As_2O_3	36
10	Diarsenic Pentaoxide	As_2O_5	39
11	Barium Oxide	BaO	42
12	Beryllium Oxide	BeO	45
13	Bismuth Sesquioxide	Bi_2O_3	48
14	Boron Sesquioxide	B_2O_3	51
15	Cadmium Oxide	CdO	54
16	Calcium Oxide	CaO	57
17	Cerium Dioxide	CeO_2	60
18	Cerium Sesquioxide	Ce_2O_3	64
19	Chromium Sesquioxide	Cr_2O_3	67
20	Cobalt Monoxide	CoO	70
21	Tricobalt Tetraoxide	Co_3O_4	73
22	Copper(ous) Oxide	Cu_2O	76
23	Copper(ic) Oxide	CuO	80
24	Dysprosium Oxide	Dy_2O_3	83
25	Erbium Oxide	Er_2O_3	86
26	Europium Oxide	Eu_2O_3	99
27	Gadolinium Oxide	Gd_2O_3	92
28	Gallium Oxide	Ga_2O_3	95
29	Germanium Dioxide	GeO_2	98
30	Hafnium Dioxide	HfO_2	101
31	Holmium Oxide	Ho_2O_3	104
32	Iron(ous) Oxide	$Fe_{0.94}O$	107
33	Iron(ic) Oxide	Fe_2O_3	110
34	Triiron Tetraoxide	Fe_3O_4	114
35	Lanthanum Oxide	La_2O_3	118

2. OXIDES (continued)

Figure and/or Table No.	Name	Formula	Page No.
36	Lead Oxide	PbO	122
37	Lead Dioxide	PbO ₂	125
38	Lead Sesquioxide	Pb ₂ O ₃	128
39	Trilead Tetraoxide	Pb ₃ O ₄	131
40	Lithium Oxide	Li ₂ O	134
41	Lutetium Sesquioxide	Lu ₂ O ₃	137
42	Magnesium Oxide	MgO	140
43	Manganese Monoxide	MnO	145
44	Manganese Dioxide	MnO ₂	148
45	Manganese Sesquioxide	Mn ₂ O ₃	151
46	Trimanganese Tetraoxide	Mn ₃ O ₄	154
47	Mercury(II) Oxide	HgO	157
48	Molybdenum Dioxide	MoO ₂	160
49	Molybdenum Trioxide	MoO ₃	163
50	Neodymium Oxide	Nd ₂ O ₃	166
51	Neptunium Dioxide	NpO ₂	169
52	Nickel Oxide	NiO	172
53	Niobium Monoxide	NbO	175
54	Niobium Dioxide	NbO ₂	178
55	Niobium Pentaoxide	Nb ₂ O ₅	181
56	Potassium Superoxide	KO ₂	184
57	Hexapraseodymium Undecaoxide	Pr ₆ O ₁₁	187
58	Plutonium Dioxide	PuO ₂	190
59	Samarium Oxide	Sm ₂ O ₃	193
60	Scandium Oxide	Sc ₂ O ₃	196
61	Silver Oxide	Ag ₂ O	199
62A	Silicon Dioxide (Quartz glass)	SiO ₂	202
62B	Silicon Dioxide (Quartz crystal)	SiO ₂	207
62C	Silicon Dioxide (Cristobalite)	SiO ₂	210
62D	Silicon Dioxide (Tridymite)	SiO ₂	213
63	Sodium Oxide	Na ₂ O	216
64	Sodium Peroxide	Na ₂ O ₂	219
65	Sodium Superoxide	NaO ₂	222
66	Strontium Oxide	SrO	225
67	Ditantalum Pentaoxide	Ta ₂ O ₅	228
68	Tellurium Dioxide	TeO ₂	231
69	Thorium Dioxide	ThO ₂	234
70	Tin Monoxide (Stannous oxide)	SnO	237
71	Tin Dioxide (Stannic oxide)	SnO ₂	240
72	Titanium Monoxide	TiO	243
73	Titanium Dioxide	TiO ₂	246
74	Titanium Sesquioxide	Ti ₂ O ₃	250
75	Trititanum Pentaoxide	Ti ₃ O ₅	253
76	Tungsten Trioxide	WO ₃	256
77	Uranium Dioxide	UO ₂	259
78	Uranium Trioxide	UO ₃	262

2. OXIDES (continued)

Figure and/or Table No.	Name	Formula	Page No.
79	Triuranium Octaoxide	U ₃ O ₈	265
80	Tetrauranium Nonaoxide	U ₄ O ₉	269
81	Vanadium Monoxide	VO	272
82	Vanadium Sesquioxide	V ₂ O ₃	275
83	Divanadium Tetraoxide	V ₂ O ₄	278
84	Divanadium Pentaoxide	V ₂ O ₅	281
85	Ytterbium Oxide	Yb ₂ O ₃	284
86	Yttrium Oxide	Y ₂ O ₃	287
87	Zinc Oxide	ZnO	290
88	Zirconium Dioxide	ZrO ₂	293

3. ANTIMONIDES

39	Aluminum Antimonide	AlSb	297
90	Gallium Antimonide	GaSb	300
91	Indium Antimonide	InSb	303

4. ARSENIDES

92	Gallium Arsenide	GaAs	307
93	Indium Arsenide	InAs	310

5. BERYLLIDES

94	Dihafnium 21-Beryllide	Hf ₂ Be ₂₁	313
95	Molybdenum Dodecaberyllide	MoBe ₁₂	316
96	Niobium Dodecaberyllide	NbBe ₁₂	319
97	Tantalum Dodecaberyllide	TaBe ₁₂	322
98	Ditantalum 17-Beryllide	Ta ₂ Be ₁₇	325
99	Titanium Dodecaberyllide	TiBe ₁₂	328
100	Zirconium 13-Beryllide	ZrBe ₁₃	331

6. BORIDES

101	Chromium Monoboride	CrB	335
102	Chromium Diboride	CrB ₂	338
103	Hafnium Diboride	HfB ₂	341
104	Magnesium Diboride	MgB ₂	345
105	Magnesium Tetraboride	MgB ₄	348
106	Molybdenum Diboride	MoB ₂	352
107	Dimolybdenum Boride	Mo ₂ B	355

xx *Grouping of Materials and List of Figures and Tables*

6. BORIDES (continued)

Figure and/or Table No.	Name	Formula	Page No.
108	Molybdenum Boride	MoB	358
109	Niobium Boride (Nonstoichiometric)	NbB _x	361
110	Niobium Diboride	NbB ₂	365
111	Tantalum Diboride	TaB ₂	368
112	Tantalum Boride	TaB	372
113	Thorium Tetraboride	ThB ₄	375
114	Titanium Diboride	TiB ₂	378
115	Tungsten Boride	WB	382
116	Ditungsten Boride	W ₂ B	385
117	Ditungsten Pentaboride	W ₂ B ₅	388
118	Zirconium Diboride	ZrB ₂	391

7. CARBIDES

119	Aluminum Carbide + ΣX_1	Al ₄ C ₃ + ΣX_1	395
120	Diberyllium Carbide + ΣX_1	Be ₂ C + ΣX_1	399
121	Tetraboron Carbide	B ₄ C	402
122	Calcium Dicarbide	CaC ₂	405
123	Trichromium Dicarbide	Cr ₃ C ₂	408
124	Pentachromium Dicarbide	Cr ₅ C ₂	411
125	Tetrachromium Carbide	Cr ₄ C	414
126	Heptachromium Tricarbide	Cr ₇ C ₃	417
127	Hafnium Carbide	HfC	420
128	Triiron Carbide	Fe ₃ C	424
129	Trimanganese Aluminum Carbide	Mn ₃ AlC	427
130	Trimanganese Zinc Carbide	Mn ₃ ZnC	430
131	Trimanganese Carbide	Mn ₃ C	433
132	Dimolybdenum Carbide	Mo ₂ C	436
133	Niobium Carbide (Nonstoichiometric)	NbC _x	439
134	Niobium Carbide	NbC	442
135	Plutonium Carbide	PuC	445
136	Silicon Carbide	SiC	448
137	Tantalum Carbide	TaC	451
138	Thorium Carbide (Nonstoichiometric)	ThC _x	454
139	Titanium Carbide	TiC	457
140	Tungsten Carbide	WC	460
141	Uranium Carbide	UC	463
142	Uranium Dicarbide	UC ₂	466
143	Uranium Carbide (Nonstoichiometric)	UC _x	469
144	Diuranium Tricarbide	U ₂ C ₃	472
145	Vanadium Carbide	VC	475
146	Zirconium Carbide	ZrC	478

8. GERMANIDES

Figure and/or Table No.	Name	Formula	Page No.
147	Dimagnesium Germanide	Mg ₂ Ge	481

9. IODIDES

148	Antimony Sulfur Iodide	SbSI	485
149	Arsenic Triiodide	AsI ₃	488
150	Cadmium Diiodide	CdI ₂	491
151	Cesium Iodide	CsI	494
152	Lead Diiodide	PbI ₂	497
153	Potassium Iodide	KI	500
154	Rubidium Iodide	RbI	503
155	Sodium Iodide	NaI	506
156	Titanium Tetraiodide	TiI ₄	510
157	Uranium Tetraiodide	UI ₄	513

10. PHOSPHIDES

158	Aluminum Phosphide	AlP	517
159	Gallium Phosphide	GaP	520
160	Indium Phosphide	InP	523

11. SELENIDES

161	Iron Diselenide	FeSe ₂	527
162	Iron Selenide (Nonstoichiometric)	Fe _x Se	530
163	Heptairon Octaselenide	Fe ₇ Se ₈	533
164	Triiron Tetraselenide	Fe ₃ Se ₄	536
165	Manganous Selenide	MnSe	539
166	Mercury Selenide	HgSe	542
167	Nickel Selenide (Nonstoichiometric)	Ni _x Se	545
168	Nickel Diselenide	NiSe ₂	549
169	Disilver Selenide	Ag ₂ Se	553
170	Silver Selenide (Nonstoichiometric)	Ag _x Se	556

12. SILICIDES

171	Trichromium Silicide	Cr ₃ Si	559
172	Pentachromium Trisilicide	Cr ₅ Si ₃	562
173	Chromium Silicide	CrSi	565
174	Chromium Disilicide	CrSi ₂	568
175	Cobalt Silicide	CoSi	571

12. SILICIDES (continued)

Figure and/or Table No.	Name	Formula	Page No.
176	Germanium Silicide (Nonstoichiometric)	Ge_xSi_y	574
177	Iron Silicide	$FeSi$	577
178	Pentairon Trisilicide	Fe_5Si_3	580
179	Triiron Silicide	Fe_3Si	583
180	Trimanganese Silicide	Mn_3Si	586
181	Manganese Silicide (Nonstoichiometric)	$MnSi_x$	589
182	Molybdenum Disilicide	$MoSi_2$	592
183	Trimolybdenum Silicide	Mo_3Si	595
184	Tantalum Disilicide	$TaSi_2$	598
185	Titanium Silicide	$TiSi$	601
186	Titanium Disilicide	$TiSi_2$	604
187	Pentatitanium Trisilicide	Ti_5Si_3	607
188	Tungsten Disilicide	WSi_2	610
189	Triuranium Silicide	U_3Si	613
190	Uranium Trisilicide	USi_3	616
191	Uranium Disilicide	USi_2	619
192	Triuranium Disilicide + Triuranium Monosilicide	$U_3Si_2 + U_3Si$	622
193	Trivanadium Silicide	V_3Si	625
194	Vanadium Disilicide	VSi_2	628
195	Pentavanadium Trisilicide	V_5Si_3	631

13. SULFIDES

196	Diantimony Trisulfide	Sb_2S_2	635
197	Arsenic Sulfide	AsS	638
198	Diarsenic Trisulfide	As_2S_3	641
199	Barium Sulfide	BaS	644
200	Dibismuth Trisulfide	Bi_2S_3	647
201	Cadmium Sulfide	CdS	650
202	Calcium Sulfide	CaS	653
203	Cerium Sulfide	CeS	656
204	Dicerium Trisulfide	Ce_2S_3	659
205	Copper Sulfide	CuS	662
206	Dicopper Sulfide	Cu_2S	665
207	Diindium Sulfide (Nonstoichiometric)	In_2S_x	668
208	Iron Sulfide (Nonstoichiometric)	Fe_xS	671
209	Iron Sulfide	FeS	674
210	Iron Disulfide	FeS_2	677
211	Lead Sulfide	PbS	681
212	Manganese Sulfide	MnS	684
213	Mercury Sulfide	HgS	687
214	Molybdenum Disulfide	MoS_2	690
215	Nickel Sulfide	NiS	693
216	Trinickel Disulfide	Ni_3S_2	696
217	Platinum Sulfide	PtS	699
218	Platinum Disulfide	PtS_2	702

13. SULFIDES (continued)

Figure and/or Table No.	Name	Formula	Page No.
219	Silver Sulfide (Nonstoichiometric)	Ag_xS	705
220	Strontium Sulfide	SrS	708
221	Strontium Disulfide	SrS_2	711
222	Zinc Sulfide	ZnS	714

14. TELLURIDES

223	Bismuth Tritelluride	Bi_2Te_3	717
224	Cadmium Telluride	$CdTe$	720
225	Digallium Tritelluride	Ga_2Te_3	723
226	Iron Telluride (Nonstoichiometric)	Fe_xTe	726
227	Iron Ditelluride	$FeTe_2$	729
228	Manganous Telluride	$MnTe$	732
229	Nickel Telluride (Nonstoichiometric)	$NiTe_x$	735
230	Nickel Ditelluride	$NiTe_2$	738
231	Palladium Telluride	$PdTe$	741
232	Palladium Ditelluride	$PdTe_2$	744
233	Platinum Telluride	$PtTe$	747
234	Platinum Ditelluride	$PtTe_2$	750
235	Disilver Telluride	Ag_2Te	753
236	Silver Telluride (Nonstoichiometric)	Ag_xTe	756

15. BROMIDES

237	Cadmium Dibromide	$CdBr_2$	759
238	Copper Bromide	$CuBr$	762
239	Potassium Bromide	KBr	765
240	Rubidium Bromide	$RbBr$	769
241	Sodium Bromide	$NaBr$	772
242	Strontium Bromide	$SrBr$	775
243	Titanium Tribromide	$TiBr_3$	778
244	Titanium Tetrabromide	$TiBr_4$	781

16. CHLORIDES

245	Barium Dichloride	$BaCl_2$	785
246	Barium Dichloride Dihydrate	$BaCl_2 \cdot 2H_2O$	788
247	Cadmium Dichloride	$CdCl_2$	791
248	Calcium Dichloride	$CaCl_2$	794
249	Cesium Chloride	$CsCl$	797
250	Chromium Dichloride	$CrCl_2$	800

16. CHLORIDES (continued)

Figure and/or Table No.	Name	Formula	Page No.
251	Chromium Trichloride	CrCl_3	803
252	Cobalt Dichloride	CoCl_2	806
253	Cobalt Dichloride Hexahydrate	$\text{CoCl}_2 \cdot 6\text{H}_2\text{O}$	909
254	Copper Dichloride	CuCl_2	812
255	Copper Dichloride Dihydrate	$\text{CuCl}_2 \cdot 2\text{H}_2\text{O}$	815
256	Dysprosium Trichloride Hexahydrate	$\text{DyCl}_3 \cdot 6\text{H}_2\text{O}$	818
257	Erbium Trichloride Hexahydrate	$\text{ErCl}_3 \cdot 6\text{H}_2\text{O}$	822
258	Gadolinium Trichloride Hexahydrate	$\text{GdCl}_3 \cdot 6\text{H}_2\text{O}$	826
259	Holmium Trichloride Hexahydrate	$\text{HoCl}_3 \cdot 6\text{H}_2\text{O}$	829
260	Iron Dichloride	FeCl_2	832
261	Lithium Chloride	LiCl	835
262	Magnesium Dichloride	MgCl_2	838
263	Magnesium Dichloride Monohydrate	$\text{MgCl}_2 \cdot \text{H}_2\text{O}$	841
264	Magnesium Dichloride Dihydrate	$\text{MgCl}_2 \cdot 2\text{H}_2\text{O}$	844
265	Magnesium Dichloride Tetrahydrate	$\text{MgCl}_2 \cdot 4\text{H}_2\text{O}$	847
266	Magnesium Dichloride Hexahydrate	$\text{MgCl}_2 \cdot 6\text{H}_2\text{O}$	850
267	Manganese Dichloride	MnCl_2	853
268	Manganous Dichloride Tetrahydrate	$\text{MnCl}_2 \cdot 4\text{H}_2\text{O}$	856
269	Neodymium Trichloride Hexahydrate	$\text{NdCl}_3 \cdot 6\text{H}_2\text{O}$	859
270	Nickel Dichloride	NiCl_2	863
271	Nickel Dichloride Hexahydrate	$\text{NiCl}_2 \cdot 6\text{H}_2\text{O}$	866
272	Phosphorus Trichloride	PCl_3	859
273	Potassium Chloride	KCl	872
274	Rhenium Trichloride	ReCl_3	878
275	Silicon Tetrachloride	SiCl_4	881
276	Silver Chloride	AgCl	884
277	Sodium Chloride	NaCl	887
278	Strontium Dichloride	SrCl_2	890
279	Titanium Trichloride	TiCl_3	893
280	Uranium Trichloride	UCl_3	896
281	Uranium Tetrachloride	UCl_4	899
282	Vanadium Dichloride	VCl_2	902
283	Vanadium Trichloride	VCl_3	905
284	Zinc Dichloride	ZnCl_2	908
285	Zirconium Tetrachloride	ZrCl_4	911

17. FLUORIDES

286	Aluminum Trifluoride	AlF_3	915
287	Barium Difluoride	BaF_2	918
288	Beryllium Difluoride	BeF_2	921
289	Calcium Difluoride	CaF_2	924
290	Cerium Trifluoride	CeF_3	927
291	Cesium Monohydrogen Difluoride	CsHF_2	931
292	Cobalt Difluoride	CoF_2	934
293	Hafnium Tetrafluoride	HfF_4	937
294	Iron Difluoride	FeF_2	940
295	Lithium Fluoride	LiF	943

17. FLUORIDES (continued)

Figure and/or Table No.	Name	Formula	Page No.
296	Trilithium Aluminum Hexafluoride	Li_3AlF_6	947
297	Dilithium Beryllium Tetrafluoride	Li_2BeF_4	950
298	Lithium Monohydrogen Difluoride	LiHF_2	953
299	Magnesium Difluoride	MgF_2	956
300	Manganese Difluoride	MnF_2	959
301	Molybdenum Hexafluoride	MoF_6	962
302	Nickel Fluosilicate Hexahydrate, A	$\text{NiSiF}_6 \cdot 6\text{H}_2\text{O}$	966
303	Nickel Fluosilicate Hexahydrate, B	$\text{Ni}_2\text{SiF}_8 \cdot 6\text{H}_2\text{O}$	970
304	Nickel Difluoride	NiF_2	973
305	Niobium Pentafluoride	NbF_5	976
306	Potassium Fluoride	KF	979
307	Potassium Hydrogen Difluoride	KHF_2	982
308	Rubidium Fluoride	RbF	985
309	Rubidium Monohydrogen Difluoride	RbHF_2	988
310	Silicon Tetrafluoride	SiF_4	991
311	Sodium Fluoride	NaF	994
312	Trisodium Aluminum Hexafluoride	Na_3AlF_6	997
313	Sodium Monohydrogen Difluoride	NaHF_2	1000
314	Strontium Difluoride	SrF_2	1003
315	Thallium Monohydrogen Difluoride	TlHF_2	1006
316	Thorium Tetrafluoride	ThF_4	1009
317	Titanium Tetrafluoride	TiF_4	1012
318	Uranium Tetrafluoride	UF_4	1015
319	Uranium Hexafluoride	UF_6	1018
320	Vanadium Trifluoride	VF_3	1021
321	Xenon Tetrafluoride	XeF_4	1024
322	Zinc Difluoride	ZnF_2	1027
323	Zirconium Tetrafluoride	ZrF_4	1030

18. HYDRIDES

324	Germanium Tetrahydride	GeH_4	1033
325	Lithium Hydride	LiH	1036
326	Tantalum Hydride	Ta_2H	1040
327	Titanium Hydride (Nonstoichiometric)	TiH_x	1044
328	Titanium Dihydride	TiH_2	1047
329	Uranium Trihydride	UH_3	1050
330	Vanadium Hydride (Nonstoichiometric)	VH_x	1053
331	Yttrium Hydride	YH_2	1056
332	Yttrium Trihydride	YH_3	1059
333	Yttrium Dideutride	YD_2	1062
334	Yttrium Trideutride	YD_3	1066
335	Zirconium Hydride (Nonstoichiometric)	ZrH_x	1069
336	Zirconium Dihydride	ZrH_2	1072

19. NITRIDES

Figure and/or Table No.	Name	Formula	Page No.
337	Aluminum Nitride	AlN	1075
338	Boron Nitride	BN	1078
339	Hafnium Nitride	HfN	1081
340	Trimagnesium Dinitride	Mg ₃ N ₂	1084
341	Silicon Nitride	SiN ^{Si₃N₄}	1087
342	Tantalum Nitride	TaN	1090
343	Titanium Nitride	TiN	1093
344	Uranium Nitride	UN	1096
345	Uranium Nitride (Nonstoichiometric)	UN _x	1099
346	Vanadium Nitride	VN	1103
347	Zirconium Nitride	ZrN	1106

20. CARBONATES

348	Barium Carbonate	BaCO ₃	1109
349	Calcium Carbonate	CaCO ₃	1112
350	Calcium Magnesium Dicarboxate	CaMg(CO ₃) ₂	1115
351	Lithium Carbonate	Li ₂ CO ₃	1118
352	Manganese Carbonate	MnCO ₃	1121
353	Dipotassium Carbonate	K ₂ CO ₃	1124
354	Disilver Carbonate	Ag ₂ CO ₃	1127
355	Disodium Carbonate	Na ₂ CO ₃	1130
356	Sodium Bicarbonate	NaHCO ₃	1133
357	Strontium Carbonate	SrCO ₃	1136

21. NITRATES and NITRITES

358	Barium Dinitrate	Ba(NO ₃) ₂	1139
359	Gadolinium Trinitrate Hexahydrate	Gd(NO ₃) ₃ · 6H ₂ O	1142
360	Potassium Nitrate	KNO ₃	1145
361	Silver Nitrite	AgNO ₂	1148
362	Sodium Nitrate	NaNO ₃	1151
363	Strontium Nitrate	Sr(NO ₃) ₂	1154
364	Thallium Nitrate	TlNO ₃	1157

22. SULFATES

365	Dialuminum Trisulfate	Al ₂ (SO ₄) ₃	1161
366	Dialuminum Trisulfate Hexahydrate	Al ₂ (SO ₄) ₃ · 6H ₂ O	1164
367	Diammonium Sulfate	(NH ₄) ₂ SO ₄	1167
368	Ammonium Aluminum Disulfate	NH ₄ Al(SO ₄) ₂	1170
369	Ammonium Aluminum Disulfate Dodecahydrate	NH ₄ Al(SO ₄) ₂ · 12H ₂ O	1173

22. SULFATES (continued)

Figure and/or Table No.	Name	Formula	Page No.
370	Barium Sulfate	BaSO ₄	1176
371	Beryllium Sulfate	BeSO ₄	1179
372	Calcium Sulfate	CaSO ₄	1182
373	Calcium Sulfate Hemihydrate	CaSO ₄ · ½H ₂ O	1185
374	Calcium Sulfate Dihydrate	CaSO ₄ · 2H ₂ O	1188
375	Cesium Aluminum Disulfate Dodecahydrate	CsAl(SO ₄) ₂ · 12H ₂ O	1191
376	Cobalt Sulfate Heptahydrate	CoSO ₄ · 7H ₂ O	1194
377	DicEuropium Trisulfate Octahydrate	Eu ₂ (SO ₄) ₃ · 8H ₂ O	1197
378	Iron Sulfate Heptahydrate	FeSO ₄ · 7H ₂ O	1200
379	Dimercury Sulfate	Hg ₂ SO ₄	1203
380	Nickel Sulfate Hexahydrate	NiSO ₄ · 6H ₂ O	1206
381	Dipotassium Sulfate	K ₂ SO ₄	1209
382	Potassium Aluminum Disulfate	KAl(SO ₄) ₂	1212
383	Potassium Aluminum Disulfate Dodecahydrate	KAl(SO ₄) ₂ · 12H ₂ O	1215
384	Disodium Sulfate	Na ₂ SO ₄	1218
385	Disodium Sulfate Decahydrate	Na ₂ SO ₄ · 10H ₂ O	1221
386	Zinc Sulfate Heptahydrate	ZnSO ₄ · 7H ₂ O	1224

23. GLASSES and CERMETS

387	Aluminosilicate Glass	SiO ₂ + Al ₂ O ₃ + ΣX _i	1227
388	Borosilicate Glass	SiO ₂ + B ₂ O ₃ + ΣX _i	1230
389	High Silica Glass	SiO ₂ + ΣX _i	1234
390	Pyroceram		1237
391	Soda Lime Glass	SiO ₂ + Na ₂ O + ΣX _i	1240
392	Beryllium + Beryllium Oxide, Cermet	Be + BeO	1243
393	Beryllium Oxide + Beryllium, Cermet	BeO + Be	1246
394	Beryllium Oxide + Beryllium + Molybdenum, Cermet	BeO + Be + Mo	1249
395	Beryllium Oxide + Molybdenum, Cermet	BeO + Mo	1252
396	Beryllium Oxide + Molybdenum Dodecaberyllide, Cermet	BeO + MoBe ₁₂	1255
397	Beryllium Oxide + Niobium Dodecaberyllide, Cermet	BeO + NbBe ₁₂	1258
398	Beryllium Oxide + Tantalum Dodecaberyllide, Cermet	BeO + TaBe ₁₂	1261
399	Beryllium Oxide + Titanium Dodecaberyllide, Cermet	BeO + TiBe ₁₂	1264
400	Beryllium Oxide + Zirconium 13-Beryllide, Cermet	BeO + ZrBe ₁₃	1267
401	Boron Nitride + Diboron Trioxide + ΣX _i , Cermet	BN + B ₂ O ₃ + ΣX _i	1270
402	Boron Nitride + Carbon, Cermet	BN + C	1273
403	Carbon + Silicon Carbide, Cermet	C + SiC	1276
404	Silicon Carbide + Carbon + ΣX _i , Cermet	SiC + C + ΣX _i	1279
405	Tungsten Carbide + Cobalt, Cermet	WC + Co	1282
406	Zirconium Dioxide + Titanium, Cermet	ZrO ₂ + Ti	1285

24. OXYGEN COMPOUNDS

Figure and/or Table No.	Name	Formula	Page No.
407	Dialuminum Silicon Pentaoxide	Al_2SiO_5	1289
408	Hexaaluminum Disilicon 13-Oxide	$Al_6Si_2O_{13}$	1292
409	Dialuminum Disilicon Heptaoxide Dihydrate	$Al_2Si_2O_7 \cdot 2H_2O$	1295
410	Dialuminum Titanium Pentaoxide	Al_2TiO_5	1298
411	Barium Silicon Trioxide	$BaSiO_3$	1301
412	Dibarium Silicon Tetraoxide	Ba_2SiO_4	1304
413	Barium Disilicon Pentaoxide	$BaSi_2O_5$	1307
414	Dibarium Trisilicon Octaoxide	$Ba_2Si_3O_8$	1310
415	Barium Titanium Trioxide	$BaTiO_3$	1313
416	Dibarium Titanium Tetraoxide	Ba_2TiO_4	1316
417	Barium Uranium Tetraoxide	$BaUO_4$	1319
418	Barium Zirconium Trioxide	$BaZrO_3$	1322
419	Beryllium Dialuminum Tetraoxide	$BeAl_2O_4$	1325
420	Diberyllium Silicon Tetraoxide	Be_2SiO_4	1329
421	Calcium Dialuminum Tetraoxide	$CaAl_2O_4$	1332
422	Calcium Tetraaluminum Heptaoxide	$CaAl_4O_7$	1335
423	Tricalcium Dialuminum Hexaoxide	$Ca_3Al_2O_6$	1338
424	Dodecacalcium 14-Aluminum 33-Oxide	$Ca_{12}Al_{14}O_{33}$	1341
425	Calcium Diboron Tetraoxide	CaB_2O_4	1344
426	Calcium Tetraboron Heptaoxide	CaB_4O_7	1347
427	Dicalcium Diboron Pentaoxide	$Ca_2B_2O_5$	1350
428	Tricalcium Diboron Hexaoxide	$Ca_3B_2O_6$	1353
429	Calcium Diiron Tetraoxide	$CaFe_2O_4$	1356
430	Dicalcium Diiron Pentaoxide	$Ca_2Fe_2O_5$	1359
431	Calcium Molybdenum Tetraoxide	$CaMoO_4$	1362
432	Calcium Silicon Trioxide	$CaSiO_3$	1365
433	Dicalcium Silicon Tetraoxide	Ca_2SiO_4	1368
434	Tricalcium Silicon Pentaoxide	Ca_3SiO_5	1371
435	Tricalcium Disilicon Heptaoxide	$Ca_3Si_2O_7$	1374
436	Calcium Titanium Trioxide	$CaTiO_3$	1377
437	Tricalcium Ditanium Heptaoxide	$Ca_3Ti_2O_7$	1380
438	Calcium Tungsten Tetraoxide	$CaWO_4$	1383
439	Calcium Uranium Tetraoxide	$CaUO_4$	1386
440	Calcium Divanadium Hexaoxide	CaV_2O_6	1389
441	Dicalcium Divanadium Heptaoxide	$Ca_2V_2O_7$	1392
442	Tricalcium Divanadium Octaoxide	$Ca_3V_2O_8$	1395
443	Calcium Zirconium Trioxide	$CaZrO_3$	1398
444	Dicalcium Dialuminum Silicon Heptaoxide	$Ca_2Al_2SiO_7$	1401
445	Calcium Dialuminum Disilicon Octaoxide	$CaAl_2Si_2O_8$	1404
446	Calcium Dialuminum Disilicon Octaoxide Dihydrate	$CaAl_2Si_2O_8 \cdot 2H_2O$	1407
447	Dicalcium Tetraaluminum Octasilicon 24-Oxide Heptahydrate	$Ca_2Al_4Si_8O_{24} \cdot 7H_2O$	1410
448	Calcium Magnesium Disilicon Hexaoxide	$CaMgSi_2O_6$	1413
449	Dicalcium Magnesium Disilicon Heptaoxide	$Ca_2MgSi_2O_7$	1416
450	Tricalcium Magnesium Disilicon Octaoxide	$Ca_3MgSi_2O_8$	1419
451	Dicalcium Pentamagnesium Octasilicon 23-Oxide Monohydrate	$Ca_2Mg_5Si_8O_{23} \cdot H_2O$	1422

24. OXYGEN COMPOUNDS (continued)

Figure and/or Table No.	Name	Formula	Page No.
452	Cobalt Diiron Tetraoxide	CoFe_2O_4	1425
453	Cobalt Iron Tetraoxide (Nonstoichiometric)	$\text{Co}_x\text{Fe}_y\text{O}_4$	1428
454	Cobalt Tungsten Tetraoxide	CoWO_4	1431
455	Copper Iron Tetraoxide (Nonstoichiometric)	$\text{Cu}_x\text{Fe}_y\text{O}_4$	1434
456	Copper Diiron Tetraoxide	CuFe_2O_4	1437
457	Triberbium Pentagallium Dodecaoxide (Garnet)	$\text{Er}_3\text{Ga}_5\text{O}_{12}$	1440
458	Iron Dialuminum Tetracxide	FeAl_2O_4	1443
459	Iron Dichromium Tetraoxide	FeCr_2O_4	1446
460	Iron Dicobalt Tetraoxide	FeCo_2O_4	1449
461	Diiron Silicon Tetraoxide	Fe_2SiO_4	1452
462	Iron Titanium Trioxide	FeTiO_3	1455
463	Lead Molybdenum Tetraoxide	PbMoO_4	1458
464	Lead Tungsten Tetraoxide	PbWO_4	1461
465	Lithium Aluminum Dioxide	LiAlO_2	1464
466	Lithium Iron Dioxide	LiFeO_2	1467
467	Lithium Iron Tetraoxide (Nonstoichiometric)	$\text{Li}_x\text{Fe}_y\text{O}_4$	1470
468	Dilithium Titanium Trioxide	Li_2TiO_3	1473
469	Lithium Zinc Iron Tetraoxide (Nonstoichiometric)	$\text{Li}_x\text{Zn}_y\text{Fe}_z\text{O}_4$	1476
470	Magnesium Dialuminum Tetraoxide	MgAl_2O_4	1479
471	Magnesium Dichromium Tetraoxide	MgCr_2O_4	1482
472	Magnesium Diiron Tetraoxide	MgFe_2O_4	1485
473	Magnesium Iron Tetraoxide (Nonstoichiometric)	$\text{Mg}_x\text{Fe}_y\text{O}_4$	1488
474	Magnesium Molybdenum Tetraoxide	MgMoO_4	1491
475	Magnesium Silicon Trioxide	MgSiO_3	1494
476	Dimagnesium Silicon Tetraoxide	Mg_2SiO_4	1497
477	Trimagnesium Tetrasilicon Undecaoxide Monohydrate	$\text{Mg}_3\text{Si}_4\text{O}_{11} \cdot \text{H}_2\text{O}$	1500
478	Dimagnesium Tetraaluminum Pentasilicon 18-Oxide	$\text{Mg}_2\text{Al}_4\text{Si}_5\text{O}_{18}$	1503
479	Magnesium Titanium Trioxide	MgTiO_3	1506
480	Magnesium Dytanium Pentaoxide	MgTi_2O_5	1509
481	Dimagnesium Titanium Tetraoxide	Mg_2TiO_4	1512
482	Magnesium Tungsten Tetraoxide	MgWO_4	1515
483	Magnesium Divanadium Hexaoxide	MgV_2O_6	1518
484	Dimagnesium Divanadium Heptaoxide	$\text{Mg}_2\text{V}_2\text{O}_7$	1521
485	Manganese Silicon Trioxide	MnSiO_3	1524
486	Trineodymium Pentagallium Dodecaoxide (Garnet)	$\text{Nd}_3\text{Ga}_5\text{O}_{12}$	1527
487	Nickel Diiron Tetraoxide	NiFe_2O_4	1530
488	Nickel Iron Tetraoxide (Nonstoichiometric)	$\text{Ni}_x\text{Fe}_y\text{O}_4$	1533
489	Nickel Zinc Diiron Tetraoxide (Nonstoichiometric)	$\text{Ni}_x\text{Zn}_y\text{Fe}_z\text{O}_4$	1536
490	Potassium Trialuminum Trisilicon Undecaoxide	$\text{KAl}_3\text{Si}_3\text{O}_{11}$	1540
491	Potassium Trialuminum Trisilicon Undecaoxide Monohydrate	$\text{KAl}_3\text{Si}_3\text{O}_{11} \cdot \text{H}_2\text{O}$	1543
492	Silicon Dioxide + Dialuminum Trioxide + ΣX_i	$\text{SiO}_2 + \text{Al}_2\text{O}_3 + \Sigma X_i$	1546
493	Sodium Aluminum Dioxide	NaAlO_2	1549
494	Sodium Boron Dioxide	NaBO_2	1552
495	Disodium Tetraboron Heptaoxide	$\text{Na}_2\text{B}_4\text{O}_7$	1556

24. OXYGEN COMPOUNDS (continued)

Figure and/or Table No.	Name	Formula	Page No.
496	Sodium Iron Dioxide	NaFeO_2	1560
497	Disodium Molybdenum Tetraoxide	Na_2MoO_4	1563
498	Disodium Dimolybdenum Heptaoxide	$\text{Na}_2\text{Mo}_2\text{O}_7$	1566
499	Disodium Silicon Trioxide	Na_2SiO_3	1569
500	Disodium Disilicon Pentaoxide	$\text{Na}_2\text{Si}_2\text{O}_5$	1572
501	Disodium Tellurium Tetraoxide	Na_2TeO_4	1575
502	Disodium Titanium Trioxide	Na_2TiO_3	1578
503	Disodium Dytanium Pentaoxide	$\text{Na}_2\text{Ti}_2\text{O}_5$	1581
504	Disodium Trititanium Heptaoxide	$\text{Na}_2\text{Ti}_3\text{O}_7$	1584
505	Disodium Tungsten Tetraoxide	Na_2WO_4	1587
506	Disodium Ditungsten Heptaoxide	$\text{Na}_2\text{W}_2\text{O}_7$	1590
507	Sodium Vanadium Trioxide	NaVO_3	1593
508	Trisodium Vanadium Tetraoxide	Na_3VO_4	1596
509	Tetrasodium Divanadium Heptaoxide	$\text{Na}_4\text{V}_2\text{O}_7$	1599
510	Sodium Aluminum Trisilicon Octaoxide	$\text{NaAlSi}_3\text{O}_8$	1602
511	Strontium Silicon Trioxide	SrSiO_3	1605
512	Distrontium Silicon Tetraoxide	Sr_2SiO_4	1608
513	Strontium Titanium Trioxide	SrTiO_3	1611
514	Distrontium Titanium Tetraoxide	Sr_2TiO_4	1614
515	Strontium Zirconium Trioxide	SrZrO_3	1617
516	Triytterbium Pentagallium Dodecaoxide(Garnet)	$\text{Yb}_3\text{Ga}_5\text{O}_{12}$	1620
517	Triyttrium Pentagallium Dodecaoxide(Garnet)	$\text{Y}_3\text{Ga}_5\text{O}_{12}$	1623
518	Zinc Diiron Tetraoxide	ZnFe_2O_4	1626
519	Dizinc Silicon Tetraoxide	Zn_2SiO_4	1629
520	Dizinc Titanium Tetraoxide	Zn_2TiO_4	1632
521	Zirconium Silicon Tetraoxide	ZrSiO_4	1635

Theory, Estimation, and Measurement

Notation

A	Grüneisen constant; Cross-sectional area	Q	Amount of heat absorbed or removed from the system
a	Lattice constant; Empirical constant	R	Gas constant, $8.3143 \text{ J K}^{-1} \text{ g-mol}^{-1}$
b	Empirical constant	s	Spin vector
c, C	Heat capacity of mass m , specific heat per unit mass	T	Temperature, K
C_a, C_f	Constant which depends on particular type of lattice and on crystal structure, respectively	t	Time
C_e	Electronic specific heat	V	Volume
C_p, C_v	Specific heat at constant pressure and constant volume, respectively	v	Specific volume
d	Density	W	Work done on or by the system
e	Base of natural logarithm, 2.71828	x, x_m	$h\nu/kT$ and $h\nu_D/kT$, respectively, as used in equation (17)
E	Total energy of an oscillator, particle, or system; Internal energy; Voltage	X_i	Atomic mole or mass fraction of i th component in an alloy or mixture
H	Enthalpy	α, α_f	Coefficient of thermal linear expansion, and a constant which depends on crystal structure, respectively
$(\Delta H)_f$	Heat of fusion	β	Coefficient of isobaric volumetric expansion; Constant in Debye cube law
h	Planck constant, $6.6262 \times 10^{-27} \text{ erg sec}$	γ	Constant in the electronic specific heat relation (26)
I	Electrical current	θ_D, θ_E	Characteristic Debye temperature and Einstein temperature, $h\nu_D/k$ and $h\nu/k$, respectively
J, J'	Quantum mechanical exchange constants	ν	Frequency of oscillation of a particle
K	Calibration factor in ice drop calorimeter	ν_D	Debye frequency
k	Boltzmann constant, $1.3806 \times 10^{-16} \text{ erg K}^{-1}$	ω	Natural angular frequency
L	Linear dimension	ρ	Electrical resistivity
m	Mass of a particle, system, or specimen	ρ_e	Number of free electrons per unit volume
m_e	Mass of an electron	ϵ	Energy of an oscillation
n	Integer, 0, 1, 2, 3, . . .	π	Mathematical constant, 3.14159 . . .
N_A	Avogadro's number, $6.0222 \times 10^{23} \text{ g-mol}^{-1}$	κ_T	Isothermal compressibility, as used in equation (36)
N_e	Number of electrons per gram atom		
p	Momentum of a particle; Pressure of a gas		
q	Direction coordinate from equilibrium position		

Theory of Specific Heat of Solids

1. INTRODUCTION

Rapid advances in the frontiers of science and technology have brought about a general realization of the fact that the present limitations in many technical developments are a direct result of inadequate knowledge of the thermophysical properties of materials. In the high-temperature range ($T > 1000$ K), interest in the determination of specific heats of materials has been hastened because of the requirements in space programs as well as industrial applications. The need for data at high temperatures has advanced our knowledge in many areas of solid state studies such as lattice vibrations, energy levels in magnetic solids, electronic distributions, and many other atomic and molecular phenomena.

The measurement of specific heat at cryogenic temperatures ($C_p \cong C_v$ for $T \leq 4$ K) provides us with a direct means to test theoretical models of a system. For instance, precise specific heat measurements were needed to test the validity of Debye's and Einstein's theory for specific heat of solids at low temperatures. Finally, knowledge of accurate specific heat data at low temperature is very useful in studies of cryogenic techniques.

2. DEFINITIONS

When a quantity of heat Q is added to a system so that there is a change in temperature, $T_2 - T_1$, then the mean heat capacity of the mass m of the substance is defined by

$$\bar{c} = \frac{Q}{T_2 - T_1} \quad (1)$$

The limiting value of the above ratio as the temperature changes by dT is defined as the true heat capacity, i.e.,

$$c = \frac{dQ^*}{dT} \quad (2)$$

* dQ is used instead of dQ to indicate that it is not an exact differential.

In order to obtain a quantity that is independent of the mass, m , of a substance, equation (2) is divided by m ; i.e.,

$$C = \frac{c}{m} = \frac{dQ}{m dT} \quad (3)$$

The quantity q represents the amount of heat per unit mass, so that equation (3) may also be written as

$$C = \frac{dq}{dT} \quad (4)$$

Raising the temperature of a unit mass of a substance by an amount dT , however, does not define the process in a thermodynamic sense; for instance, it will take a different amount of heat dq if the process is at constant pressure than when the process is at constant volume. As a matter of fact there are an infinite number of different processes for a system at temperature T to change to a temperature $T + dT$. It is clear, therefore, that an infinite number of specific heats could also be defined for a substance. The two processes that are most commonly used in thermodynamics are those at constant volume and constant pressure. For these two processes equation (4) may be written

$$C_p = \left(\frac{dq}{dT} \right)_p \quad (5)$$

and

$$C_v = \left(\frac{dq}{dT} \right)_v \quad (6)$$

Experimentally, the values of the specific heat measured are either at constant pressure, C_p , or at constant volume, C_v . The units most commonly used for specific heat are $\text{cal g}^{-1} \text{K}^{-1}$, $\text{Btu lb}^{-1} \text{F}^{-1}$, $\text{joules kg}^{-1} \text{K}^{-1}$. The units for molar or atomic specific heat are $\text{cal g-mol}^{-1} \text{K}^{-1}$, $\text{Btu lb-mol}^{-1} \text{F}^{-1}$, $\text{joules kg-mol}^{-1} \text{K}^{-1}$, $\text{cal g-atom}^{-1} \text{K}^{-1}$, $\text{joules kg-atom}^{-1} \text{K}^{-1}$, etc.

3. DULONG AND PETIT'S LAW

In 1819 Dulong and Petit [9] published the results of their measurements on the specific heat at constant pressure of thirteen solid elements at room temperature. From these measurements, they observed that the product of the specific heat at constant pressure and the atomic weight was approximately a constant, about 6 cal g-atom⁻¹ K⁻¹. Subsequent researches, extending from 1840 to 1862, revealed the general applicability of the Dulong and Petit's law to several metallic elements, when the specific heat at constant pressure was determined at temperatures sufficiently below their melting point but not far below room temperature. During the same period an important extension of Dulong and Petit's law was applied to chemical compounds, i.e., the molar specific heat of a compound is equal to the sum of the atomic specific heats of its constituent elements. This law which is generally referred to as the Kopp-Neumann law [32] has also been applied to predict the atomic specific heat of alloys. For alloys, the atomic specific heat is equal to the sum of the product of the atomic specific heat of each constituent element and its atomic fraction. If an alloy consists of elements 1, 2, 3, . . . , *n*, with atomic fraction $X_1, X_2, X_3, \dots, X_n$ and atomic specific heat $C_{p1}, C_{p2}, C_{p3}, \dots, C_{pn}$, then the atomic specific heat of the alloy is

$$C_p = \sum_{i=1}^n X_i C_{p_i} \quad (7)$$

Equation (7) should be applied with caution for alloys especially near magnetic and phase transitions. Bottema and Jaeger [5] have applied the Kopp-Neumann law to the alloy Ag₃Au and they found that the experimental data on the specific heat at constant pressure of this alloy agree closely with the calculated values between 0 C to 400 C. Between 400 C and 800 C, the values obtained from the Kopp-Neumann law were 0.5 percent to 1.8 percent higher than the experimental results. Buyco [46] calculated the specific heat of the alloys of aluminum, beryllium, nickel, and iron between 300 K to 1000 K and found the calculated values agree with the experimental data to within 5 percent.

The theoretical justification of the law of Dulong and Petit was demonstrated by Boltzmann in 1871. The results obtained previously by Dulong and Petit also follow from Boltzmann's equipartition of energy theorem. Complete and detailed derivation of this theorem is discussed elsewhere [15, 20, 21, 33, and 43].

The following is a brief exposition. The energy of a linear harmonic oscillator consists of kinetic and potential energies, i.e.,

$$E = \frac{p^2}{2m} + \frac{m\omega^2 q^2}{2} \quad (8)$$

where p is the momentum, m is the mass, ω is the natural angular frequency, q is the distance from equilibrium position, and E is the total energy of an oscillator. From the theorem of equipartition of energy [15, 20, 21, 31], each degree of freedom contributes ($kT/2$) to the energy of a particle in equilibrium. A three-dimensional oscillator which has six degrees of freedom will therefore have an internal energy of $3kT$ at thermal equilibrium. A gram-atom of an element has N_A atoms; hence, the internal energy is $3N_A kT$. The specific heat at constant volume is obtained by differentiating the internal energy with respect to temperature at constant volume, i.e.,

$$\left(\frac{\partial E}{\partial T}\right)_v = C_v = 3N_A k \quad (9)$$

where N_A is the Avogadro constant and k is the Boltzmann constant. The product of Avogadro constant and Boltzmann constant is equal to the gas constant R . Therefore:

$$C_v = 3R \approx 5.96 \text{ cal mol}^{-1} \text{ K}^{-1}$$

Hence, the Dulong and Petit value of about 6 cal mol⁻¹ deg⁻¹ for the specific heat of metallic solids can be accounted for on the basis of classical statistical mechanics. However, the observation of Dulong and Petit was short lived. In 1875 Weber [48] showed that the atomic specific heat of silicon, boron, and carbon are considerably lower than the values predicted by Dulong and Petit. For example, the atomic specific heat of crystalline silicon, boron, and diamond were found to be 4.8, 2.7, and 1.8 cal mol⁻¹ deg⁻¹, respectively, at room temperature. Subsequent specific heat measurements at low temperatures ($T < 300$ K) revealed that the specific heat of solids increased rapidly with temperature and almost leveled off about their Debye temperature. Classical theory does not explain this behavior for solids. It should also be noted that classical theory encounters the same difficulty in the behavior of molar specific heats.

4. EINSTEIN'S SPECIFIC HEAT THEORY

Einstein [10] proposed a simple model to account

for the decrease in the specific heat at low temperatures below the value $3R$ per mole which was obtained at elevated temperatures. His oversimplified physical model considers the thermal properties of the vibrations of a lattice of N_A atoms as a set of $3N_A$ independent harmonic oscillators in one dimension, each with the same frequency, ν . He then quantized the energy of the oscillators in accordance with the results obtained by Planck. According to Planck, a harmonic oscillator does not have a continuous energy spectrum but can accept energy values equal to an integer times $h\nu$, where ν is the frequency of oscillations and h is the Planck constant. Hence the possible energy levels of an oscillator may be given by

$$\epsilon = n h \nu \quad n = 0, 1, 2, 3, \dots$$

The average energy of an oscillator at temperature T , according to the well known Planck formula [7, 20, 21, 32], is

$$\bar{\epsilon} = \frac{h\nu}{\exp(h\nu/kT) - 1} \quad (10)$$

In Einstein's model the vibrational energy of a solid element containing N_A atoms is $3N_A$ times the average energy of an oscillator, i.e.,

$$\bar{E} = 3N_A \frac{h\nu}{\exp(h\nu/kT) - 1} \quad (11)$$

The results obtained from quantum mechanics however showed that the average energy of an oscillator [7, 15] should be written as

$$\bar{\epsilon} = \frac{h\nu}{2} + \frac{h\nu}{\exp(h\nu/kT) - 1} \quad (12)$$

instead of as in equation (10).

The result obtained for the specific heat by differentiating equation (10) is the same as that obtained from equation (12). In any case the specific heat for one atom of an element is

$$\left(\frac{\partial E}{\partial T}\right)_v = C_v = \frac{3N_A k (h\nu/kT)^2 \exp(h\nu/kT)}{[\exp(h\nu/kT) - 1]^2} \quad (13)$$

For convenience, the characteristic Einstein temperature defined by $\theta_E = h\nu/k$ may be introduced in equation (13) to obtain

$$C_v = \frac{3R(\theta_E/T)^2 \exp(\theta_E/T)}{[\exp(\theta_E/T) - 1]^2} \quad (14)$$

In the high-temperature range with $T \gg \theta_E$ [15, 20, 21, 32], equation (14) upon expansion in power series becomes

$$C_v \cong 3R \left[1 - \frac{1}{12} \left(\frac{\theta_E}{T} \right)^2 \right] \quad (15)$$

When the value of $[(\theta_E/T)^2/12]$ is such that it is very much smaller than 1, then Einstein's theory yields the classical Dulong and Petit value of $6 \text{ cal mol}^{-1} \text{ deg}^{-1}$.

In the low-temperature region $T \ll \theta_E$, equation (14) may be written approximately as

$$C_v \cong 3R \left(\frac{\theta_E}{T} \right)^2 \exp(-\theta_E/T) \quad (16)$$

According to equation (16), the low-temperature specific heat of solids should approach zero exponentially. Experimental evidence indicates that C_v approaches zero more slowly than this. The reason for the discrepancy between Einstein's theoretical prediction and the experimental results may be explained on the basis of the assumption made in the theory that each atom in a solid vibrates independently of the others but with precisely the same frequency. However, in spite of the weakness in Einstein's theory, his pioneering work opened the way for the application of quantum theory to the specific heat of solids.

5. DEBYE'S SPECIFIC HEAT THEORY

From the point of view of the wave whose wavelength is large compared with the interatomic distances, a crystal may appear like a continuum. The fundamental assumption of Debye [6] is that the continuum model may be employed for all possible vibrational modes of the crystal. Debye has given a limit to the total number of vibrational modes equal to $3N_A$, where N_A is the number of atoms in a gram atom of an element. In this case, the frequency spectrum which corresponds to an ideal continuum is cut off in order to comply with a total of $3N_A$ modes. This procedure should provide a maximum frequency ν_D (Debye frequency) which is common to both the longitudinal and transverse modes. By associating with each vibrational mode a harmonic oscillator of the same frequency, Debye obtained the following expression [7, 15, 20, 21, 32] for the vibrational energy:

$$\bar{E} = 9N_A h \nu_D \left(\frac{kT}{h\nu_D} \right)^4 \int_0^{x_m} \frac{x^3 dx}{e^x - 1} \quad (17)$$

where

$$x = hv/kT \quad x_m = hv_D/kT$$

Clearly, when $T \gg \theta_D$, x_m is small compared with unity for the whole integration range. In this case $e^x - 1 \cong x$ so that equation (17) could easily be integrated to obtain the expression

$$\bar{E} \cong 3N_A kT \quad (18)$$

Then

$$\left(\frac{\partial \bar{E}}{\partial T}\right)_v = C_v = 3N_A k = 3R \cong 6 \text{ cal mol}^{-1} \text{ deg}^{-1}$$

a result agreeing with classical theory.

At very low temperatures, $T \ll \theta_D$, the upper limit of integration in equation (17) may be replaced by infinity since $hv/kT \rightarrow \infty$ as $T \rightarrow 0$. It is now possible to integrate equation (17) as follows [51]

$$\int_0^\infty \frac{x^3 dx}{e^x - 1} = 6 \sum_1^\infty \frac{1}{n^4} = \frac{\pi^4}{15} \quad (19)$$

Hence

$$\bar{E} = \frac{3}{5} \pi^4 N_A k T \left(\frac{T}{\theta_D}\right)^3 \quad (20)$$

and

$$C_v = \left(\frac{\partial \bar{E}}{\partial T}\right)_v = \frac{12}{5} \pi^4 N_A k \left(\frac{T}{\theta_D}\right)^3 \quad (21)$$

or

$$C_v = \frac{12}{5} \pi^4 R \left(\frac{T}{\theta_D}\right)^3 \quad (22)$$

For one atom or one mole of a substance, $R = 1.987 \text{ cal mol}^{-1} \text{ deg}^{-1}$ so that equation (22) may be written as

$$C_v = 464.5 \left(\frac{T}{\theta_D}\right)^3 \text{ cal mol}^{-1} \text{ deg}^{-1} \quad T < \left(\frac{\theta_D}{50}\right) \quad (23)$$

Debye's theory predicts a cube law dependence of the specific heat of the elements for temperatures $T < (\theta_D/10)$. The range of validity of this law [15] has now been restricted to $T < (\theta_D/50)$ as a result of more recent theoretical work on specific heat studies. The predictions of Debye's theory agree quite well with experimental values of the specific heat of solids and is a definite improvement over Einstein's work.

Due to improved calorimetric measurements at low temperatures ($T < 5 \text{ K}$), in recent years accurate

specific heat values revealed that Debye's equation for C_v does not fit the experimental results precisely. Furthermore, it was observed that θ_D , which according to Debye's theory is a constant, did in fact vary with temperature. The deficiency of the Debye theory may be explained on the basis of the approximation made in treating solids as a continuous elastic media and neglecting the discreteness of the atoms.

Further improvements on Debye's theory was developed by Born and Karman [4]. They calculated the frequency spectrum by considering the lattice modes of vibration for a particular crystal structure under investigation. The method is involved so that one is referred to the original work [4] for detailed discussion.

6. ELECTRONIC SPECIFIC HEAT

In 1900, Drude [8] suggested a model for a free-electron theory of metals. He assumed that metals contain free electrons in thermal equilibrium with the atoms of the solid. He further assumed that the potential energy of the free electrons is equal to the product of the number of electrons per unit volume and the average energy of an electron. The essential feature in the problem is the determination of the number of electrons with energy between E and $E + dE$. Classical theory using Maxwell-Boltzmann statistics [2, 8, 15, 20, 21, 32, 43], would give an expression for the electronic specific heat as

$$C_e = \frac{3}{2} N_e k \quad (24)$$

Using Fermi-Dirac statistics [7, 15, 19, 20, 21, 31, 32], the following expression for the electronic specific heat may be obtained at low temperatures:

$$C_e = \pi^2 K (2m_e k/h^2) \left(\frac{\pi}{3\rho_e}\right)^{2/3} T \quad (25)$$

or simply

$$C_e = \gamma T \quad (26)$$

where ρ_e is the number of free electrons per unit volume, γ is the proportionality constant, T is the absolute temperature, N_e is the number of electrons per gram atom, m_e is the mass of an electron, k is the Boltzmann constant, h is the Planck constant, R is the gas constant, and C_e is the electronic specific heat.

The specific heat of metals below the Debye temperature and "very much" below the Fermi temperature [15, 19, 20, 21, 32] may be expressed as

the sum of the electronic specific heat and the lattice specific heat, i.e.,

$$C_v = \gamma T + \beta T^3 \quad (27)$$

Indeed, this relationship has been verified by accurate low temperature specific heat measurements. At sufficiently low temperature ($T < 1$ K) the electronic specific heat is dominant, while at high temperatures the lattice contribution is predominant.

7. MAGNETIC SPECIFIC HEAT

There are two types of materials that exhibit a magnetic contribution to the total specific heat: namely, the ferromagnetic and the ferrimagnetic materials.

A ferromagnet is a material [7, 15, 20, 21, 32] that contains a spontaneous magnetic moment. This means that this material possesses a magnetic moment even in the absence of an external magnetic field. This type of material exhibits a magnetic ordering with parallel alignment of adjacent spins. A ferromagnetic material has a Curie temperature, T_c , which is defined as the temperature above which magnetization disappears, and the material becomes paramagnetic. The Curie temperature separates the ordered ferromagnetic phase from the disordered paramagnetic phase.

An antiferromagnet is a material [7, 15, 20, 21, 32], that has spins which are ordered in an antiparallel arrangement. There is no net magnetic moment at temperatures below the Néel temperature. Hysteresis is usually observed and a sharp maximum in the susceptibility curve is exhibited. Above the Néel temperature, the spins are said to be free, and the material becomes paramagnetic. In some ways ferrimagnetic materials are similar to the ferromagnetic materials except that in the former the adjacent spins are unequal and antiparallel. The Néel temperature may be defined for ferrimagnetic material as the temperature separating the ordered ferrimagnetic phase from the disordered paramagnetic phase.

For ferri- and ferromagnets, the internal energy [7, 15, 20, 21, 32], is given by the expression

$$\bar{E} = 4\pi V(2\alpha_f J_s a^2) \left(\frac{kT}{2\alpha_f J_s a^2} \right)^{5/2} \int_0^x \frac{x^4 dx}{e^{x^2} - 1} \quad (28)$$

At low temperatures the upper limit for x may be taken equal to infinity and hence the integral may be easily determined. Differentiating equation (28) gives the magnetic specific heat [15]

$$C_M = \frac{d\bar{E}}{dT} = C_f N_A k \left(\frac{kT}{2J_s} \right)^{3/2} \quad (29)$$

where α_f and C_f are constants which depend upon crystal structure, a is the lattice constant, J is the quantum mechanical exchange constant, k is the Boltzmann constant, N_A is the Avogadro number, s is the magnitude of the spin vector, and V is the volume of the material.

Equation (29) shows that at low temperatures the ferromagnetic contribution to the specific heat is proportional to the three-halves power of the absolute temperature. For metals which are ferromagnetic [15], the total specific heat is equal to the sum of the electronic, lattice, and magnetic terms, i.e.,

$$C_v = \gamma T + \beta T^3 + \delta T^{3/2} \quad (30)$$

For ferrimagnets, which are electrical insulators, [15], the electronic term is negligible compared with the other terms, so that the total specific heat may be given by the expression

$$C_v = \beta T^3 + \varepsilon T^{3/2} \quad (31)$$

Both sides of equation (31) may be divided by $T^{3/2}$ to give

$$C_v/T^{3/2} = \beta T^{3/2} + \varepsilon \quad (32)$$

A plot of $C_v/T^{3/2}$ versus $T^{3/2}$ should give a straight line with slope β and intercept ε .

For the case of antiferromagnetic materials [15], the expressions for the mean internal energy is

$$\bar{E} = 4\pi V(2\alpha_a J_s a^2) \left(\frac{kT}{2\alpha_a J_s a^2} \right)^4 \int_0^x \frac{x^3 dx}{e^{x^2} - 1} \quad (33)$$

The upper limit for integration may be taken as equal to infinity at low temperatures so that differentiation of equation (33) gives the magnetic specific heat [15, 28]

$$C_M = C_a N_A k \left(\frac{kT}{2J_s} \right)^3 \quad (34)$$

where C_a is a constant which depends upon the type of lattice and J is the magnitude of the exchange constant.

The striking difference between the contributions to the specific heat exhibited by ferromagnets and ferrimagnets is the $T^{3/2}$ dependence in the former and T^3 dependence in the latter. Hence for antiferromagnetic materials, the temperature dependence is of the same form as the Debye's T^3 formula. The separation of the spin wave contribution from the lattice specific heat in antiferromagnetic materials is indeed very difficult.

8. LOW-TEMPERATURE SPECIFIC HEAT

The specific heat of solids is ordinarily measured at constant pressure. The specific heat at constant volume is that which is obtained if the interatomic distance is kept constant as the temperature changes. The specific heat at constant volume, C_v , may be assumed to be approximately equal to the specific heat at constant pressure, C_p , at cryogenic temperatures. At high temperatures, $C_p > C_v$. This difference is obtained from the classical thermodynamic relations

$$C_p - C_v = -T \left(\frac{\partial V}{\partial T} \right)_p^2 / \left(\frac{\partial V}{\partial p} \right)_T \quad (35)$$

From the definition of the isothermal compressibility

$$\kappa_T = - \left(\frac{\partial V}{\partial p} \right)_T / V \quad (36)$$

and the isobaric coefficient of volumetric expansion

$$\beta = \left(\frac{\partial V}{\partial T} \right)_p / V \quad (37)$$

Using equations (36) and (37), equation (35) may be written as

$$C_p - C_v = \frac{TV\beta^2}{\kappa_T} \quad (38)$$

By rearranging equation (38), this may also be written as

$$C_p - C_v = \left(\frac{V\beta^2}{\kappa_T C_p^2} \right) C_p^2 T = AC_p^2 T \quad (39)$$

where

$$A = \frac{V\beta^2}{\kappa_T C_p^2}$$

The parameter A is called the Grüneisen constant, which is actually only approximately constant [15] over a wide range of temperature. If A is calculated at any one temperature from values of V , β , and κ_T , it may be used [15, 20, 21, 32] to calculate $C_p - C_v$ over a wide range of temperature without introducing a serious error.

For isotropic substances, the isothermal coefficient of volumetric expansion may be written in terms of the coefficient of linear expansion

$$\beta = \left(\frac{\partial V}{\partial T} \right)_p / V = 3 \left[\left(\frac{\partial L}{\partial T} \right)_p / L \right] = 3\alpha \quad (40)$$

Hence, from equation (38)

$$C_p - C_v = \frac{9\alpha^2}{\kappa_T} TV = \left(\frac{9V\alpha^2}{\kappa_T C_p^2} \right) C_p^2 T \quad (41)$$

where

$$A = \frac{9V\alpha^2}{\kappa_T C_p^2}$$

In the absence of contributions from magnetic and nuclear specific heat, the expression for C_v for most metals has been shown [15, 20, 21, 32] to be

$$C_v = \gamma T + \beta T^3 \quad (27)$$

where γT is the electronic contribution and βT^3 is the lattice contribution. For nonmetals, the electronic contribution may be very small compared with the lattice term so that

$$C_v = \beta T^3 \quad (42)$$

When the nuclear quadrupole moment interacts with the electronic field gradient of the lattice and the electron, then the total specific heat of the substance is given as

$$C_v = \gamma T + \beta T^3 + \alpha T^{-2} \quad (43)$$

where αT^{-2} is the nuclear contribution to the total specific heat.

9. NORMAL AND SUPERCONDUCTING MATERIALS

At a certain critical temperature (superconducting temperature), several materials exhibit superconducting behavior [15, 20, 21, 32]. Below this temperature, the specific heat of a superconducting material is found to depart significantly from the values obtained for a normally behaving material. It is also found that if an external magnetic field of sufficient strength is applied while the specific heat of the material is being measured, the values obtained correspond to what the normal values would be. Hence, the specific heat values obtained experimentally in the presence of sufficient external magnetic field below the superconducting critical temperature are referred to as the normal specific heat (C_N) while the values obtained in the absence of a magnetic field are referred to as superconducting specific heat (C_S). For example, the critical superconducting temperatures of aluminum and niobium are approximately 1.196 K and 9.22 K, respectively.

Other Major Sources of Data

There exists in the literature a number of reference sources which, while less extensive in scope, may nevertheless prove valuable to the reader. While it is not the intent here to cite every available review, it is felt that the following works, listed in chronological order, are of particular significance. One should note that most of the citations do not present critical evaluation of the data they report.

Furukawa, Saba, and Reily [12] report on the critical analysis of the thermodynamic properties of copper, silver, and gold between 0 and 300 K. A tabulation is given for the values of specific heat C_p , enthalpy $H - H_0^0$, entropy S^0 , Gibbs energy $G - H_0^0$, enthalpy function $(H - H_0^0)/T$ and Gibbs energy function $(G - H_0^0)/T$. The report also contains a comparison of the values of the electronic coefficient of the specific heat and the 0 K limiting Debye characteristic temperature with their selected values. An appraisal of low-temperature calorimetry is also given.

Touloukian [44] edited a handbook entitled *Thermophysical Properties of High Temperature Solid Materials* consisting of nine books totaling more than 8500 pages. The properties covered in the handbook are density, melting point, heat of fusion, heat of vaporization, heat of sublimation, electrical resistivity, specific heat at constant pressure, thermal conductivity, thermal diffusivity, thermal linear expansion, thermal radiative properties (absorptance, emittance, reflectance, and transmittance), and vapor pressure. Generally, only materials with melting points above 800 K are included, except for materials within the categories of polymers, plastics, and composites.

Touloukian, Gerritsen, and Moore [45], *Thermophysical Properties Research Literature Retrieval Guide*, consisting of a set of three books, contains references for 33,700 research documents on thermophysical properties of matter. The properties covered are thermal conductivity, specific heat at constant pressure, viscosity, thermal radiative properties (emissivity, absorptivity, reflectivity, transmissivity),

optical constants (total and spectral), diffusion coefficient, thermal diffusivity, and Prandtl number. This publication supersedes the earlier works of this series (Volume I, 1960 and Volume II, 1963), and constitutes an enlarged and consolidated definitive work reporting the total literature through June 1964.

Schick [29] edited a comprehensive work entitled *Thermodynamics of Certain Refractory Compounds*. Volume 2 of this work includes thermodynamic properties of borides, carbides, nitrides, and oxides of 31 elements in the temperature range from 0 to 6000 K. Over 160 thermodynamic tables, together with comprehensive discussions, are presented.

Moeller et al.'s [24] compilation on *Thermophysical Properties of Thermal Insulating Materials* should prove useful in cryogenic and high temperature applications. The properties included in this compilation are thermal conductivity, thermal linear expansion, specific heat, total normal emittance, thermal diffusivity, compressive strength, density, melting point, and modulus of elasticity. Various experimental methods for determining thermal properties are described and their accuracies are indicated.

Wood and Deem [52] report on the compilation of specific heat, thermal linear expansion, and thermal conductivity data for materials of possible structural usefulness above 1500 K. Data are presented graphically with notations as to measurement methods and test conditions.

Hultgren, Orr, Anderson, and Kelley [16] published their book on the *Selected Values of Thermodynamic Properties of Metals and Alloys* in 1963. This book presents in tabular form heat capacity, enthalpy, entropy, free energy function, and vapor pressure. In some cases the heat of fusion, melting point, and other transition temperatures are also given. For the binary alloys, phase diagrams are included.

Eldridge and Deem [11] issued a report under the auspices of the Data and Publication Panel of

ASTM-ASME joint committee on effects of temperature on the properties of metals. The metals covered are Al, Co, Fe, Mg, Mo, Ni, and their alloys. The properties included are thermal conductivity, thermal linear expansion, specific heat, electrical resistivity, density, emissivity, diffusivity, and magnetic permeability. Emphasis is given to data over a range from cryogenic (2 K) to elevated temperatures (2800 K).

Johnson [17] edited a compendium of the properties of materials at low temperatures. The first phase of the compendium covers properties of ten fluids (Part I), properties of solids (Part II), and an extensive bibliography of references (Part III). The properties covered are density, expansivity, thermal conductivity, specific heat, enthalpy, heats of transition, phase equilibria, dielectric constants, adsorption, surface tension, and viscosity for solid, liquid, and gas phases of He, H₂, Ne, N₂, O₂, air, CO, F₂, A, and NH₃. Data sheets, primarily in graphic form, are

presented for "best values" of data collected. The sources of the materials used, other references, and tables of selected values with appropriate comments are furnished with each data sheet.

Kelley's [18] bulletin contains the then-available high-temperature specific heat data for the elements and inorganic compounds. The thermodynamic properties are listed in tables and algebraic expressions for their representations are also given.

Stull and Sinke [40] published their well-known reference work on the *Thermodynamic Properties of the Elements* in 1956. This book reports specific heat as well as thermodynamic property values for the elements in their condensed and gaseous state. A search of the literature was made by the authors through 1955. Whenever experimental data were not available, reasonable estimates were made in order to fill the gaps in information. A tabulation of thermodynamic values from 298.15 K to 3000 K is given for the elements.

Methods for the Measurement of the Specific Heat of Solids

1. INTRODUCTION

There are few methods for the practical and precise determination of the specific heat of solids. Although many variants and minor modifications or improvements are reported in the various references cited in this section, the most important ones are described in detail in reference [54]. References [55] to [61] also constitute major works on calorimetry including various specialized applications.

The primary methods for the measurement of the specific heat of solids which are commonly used are the method of mixtures or drop method, adiabatic method, comparative method, pulse-heating method, and modifications of these. A number of specific calorimetric techniques are briefly described in this section.

The method of mixtures [14, 37, 50] is widely employed for measuring specific heats of solids above room temperature. This method frequently gives accurate results in a temperature range where no phase transition exists. The usual method consists of dropping the substance under investigation from a furnace temperature into a calorimeter (at room or ice temperature) and the quantity that is obtained directly is the change in enthalpy. Heat capacities are obtained from these values by differentiation, i.e., $C_p = (\partial H / \partial T)_p$. This method is inherently not suitable for use with substances which undergo phase transitions over the temperature range of interest or whose specific heat is highly temperature sensitive.

Various methods of obtaining directly the true specific heat based on the Nernst calorimeter [38, 42, 47, 49] have been used successfully in obtaining precise data in the temperature range below room temperature. Attempts to use this method at moderately high temperatures have not produced accurate results because of heat exchange with the

surroundings. This method involves the measurement of energy required to raise the temperature of the substance over small temperature intervals from a fraction of a degree to a few degrees.

2. NERNST-TYPE ADIABATIC VACUUM CALORIMETER

A typical adiabatic vacuum calorimeter consists of a block over which an insulated coil of platinum wire is wound. The block may be either a solid sample under investigation or a container for the solid sample. The block is suspended by leads in a vacuum-tight container. The container is cooled in a dewar containing liquid air, hydrogen, or helium, depending on the temperature range involved. At the start of the operation, the vacuum-tight container is filled with helium gas at very low pressure while the block is cooled to the bath temperature by heat transfer through the helium gas. After the block has been cooled, the gas is removed by pumping and a known amount of heat is applied to the platinum coil by means of electric current for a given time interval. The temperature rise of the block is measured by means of a suitable resistance thermometer. The specific heat is then determined from the measured heat input and temperature change of the sample. Improved versions of the Nernst-type adiabatic calorimeter are described by Taylor and Smith [42], Wallace *et al.* [47], and Westrum [49].

The calorimeter assembly which is discussed by Wallace *et al.* [47] consisted of the sample container, the thermal shields, the outer jacket with associated radiation shields, and the vacuum system. Figure 1 presents a schematic diagram of the calorimeter.

3. MODIFIED ADIABATIC CALORIMETER

A modification of the direct method has been applied successfully by Schmidt and Leidenfrost [30]

to obtain the specific heats of powders and granular materials from 273 K to 773 K. The determination of specific heats was carried out for Mond Nickel (99.85% Ni) with an accuracy of 0.6 percent.

The theory of the method as employed for a continuously heated adiabatic calorimeter for measuring powders and granular materials is discussed in detail in reference [30].

Consider a calorimeter and sample system with negligible heat loss to the surroundings, then the heat input may be expressed as

$$\frac{dQ}{dt} = mC_p \frac{dT}{dt} + W_c \frac{dT}{dt} \quad (44)$$

where dQ/dt is the heat input per unit time, T is the temperature, t is the time, m is the mass of the specimen, W_c is the thermal constant of calorimeter body and heater element, energy per degree, and C_p is the specific heat of specimen. From equation (44),

$$C_p = \frac{1}{m} \left[\frac{dQ/dt}{dT/dt} - W_c \right] \quad (45)$$

It is desirable to achieve as small a temperature variation as possible if the specific heat is assumed

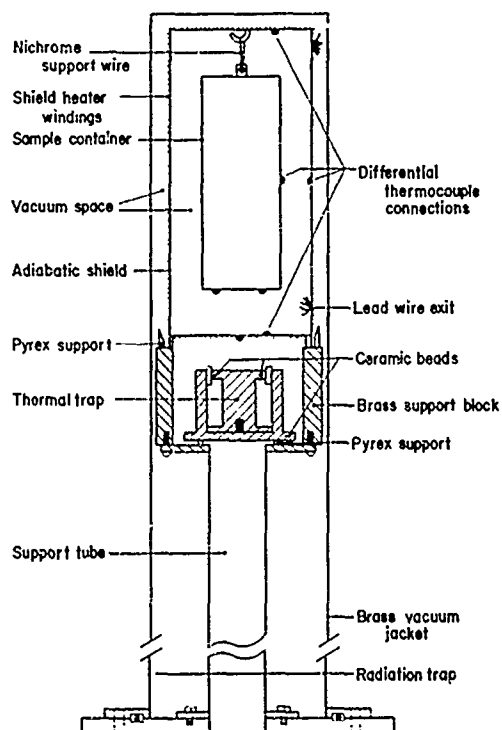

Fig. 1. Schematic diagram for adiabatic specific heat calorimeter [47].

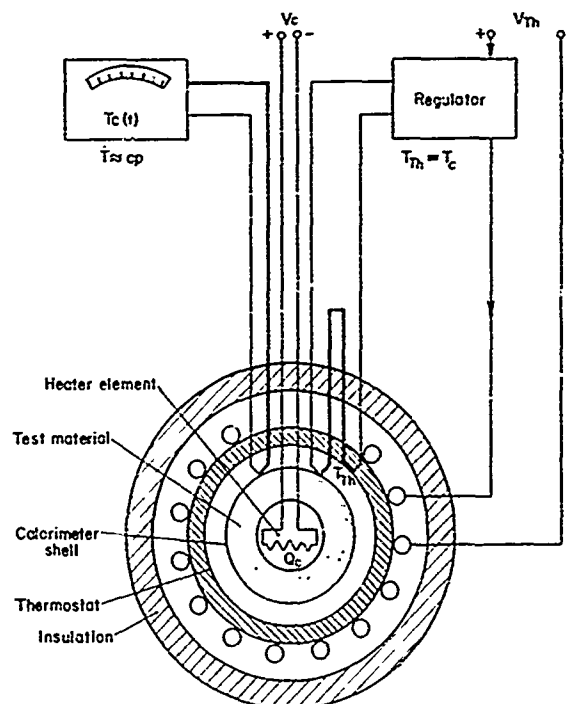

Fig. 2. Schematic diagram for spherical adiabatic calorimeter [30].

constant during each measurement interval. On the other hand, this temperature variation must be large enough to lend itself to precision measurement. The heating must be such that steady-state condition is reached within a reasonable length of time. Schmidt and Leidenfrost [30] have shown that for powders or granular materials of low thermal diffusivity, the following assumptions can be satisfied well enough to yield accurate measurements:

1. The temperature field is dependent only on time and the radial coordinate.
2. The sample is uniformly homogeneous, and its properties are constant over small temperature differences.
3. The sum of the heat capacities of the calorimeter body and its inside heater is small compared with the heat capacity of the sample mass.

The experimental arrangement of the apparatus is shown in schematic form in Fig. 2.

4. DROP ICE CALORIMETER

In this method [13] the heat given off by the sample is used to melt a portion of the ice in an equilibrium ice-water bath and the resulting change

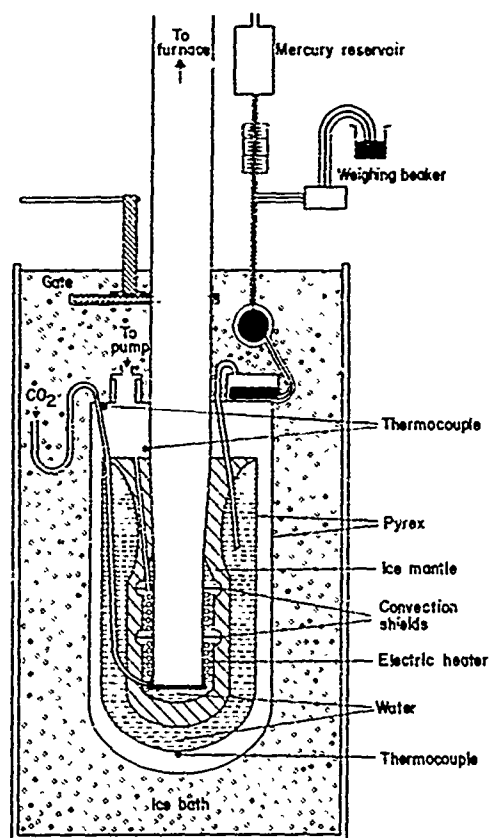

Fig. 3. Schematic diagram for drop ice calorimeter [13].

in volume of the bath is measured by the change in height of a mercury column. The calibration factor for a particular calorimeter (ratio of heat input to mass of mercury displaced by melted ice) is determined from the following expression:

$$K = \Delta H_f / (v_i - v_w) d_m \quad (46)$$

where K is the calibration factor, ΔH_f is the heat of fusion of ice, v_i is the specific volume of ice, v_w is the specific volume of water, and d_m is the density of mercury.

The calibration factor K relates the enthalpy change of the specimen to the height of the mercury column. Values of $(H_T - H_{273.15})$ are then determined for various initial specimen temperatures. These data are either represented graphically or by a suitable empirical relation. The specific heat curve is either derived from the graphically smoothed enthalpy data or from the equation

$$C_p = \frac{d}{dT}(H_T - H_{273.15})_p$$

A schematic drawing of the ice calorimeter is shown in Fig. 3. A central well is provided to receive the specimen whose enthalpy is to be determined. An electric heater, sheathed in a metal tube, is soldered on the outside of the well in order to introduce known amounts of heat for calibration purposes. The lower portion of the well is surrounded by two coaxial glass vessels which provide an insulating space between the inner ice-water system and the surrounding ice bath. Any volume change resulting from the melting of ice in the inner vessel displaces an equivalent volume of mercury and is collected in a beaker and weighed to account for the change in mercury in the calorimeter. A special gate prevents heat transfer from above to the calorimeter along the central well.

5. DROP ISOTHERMAL WATER CALORIMETER

In the drop water calorimeter a sample is heated in the furnace and dropped into the calorimeter

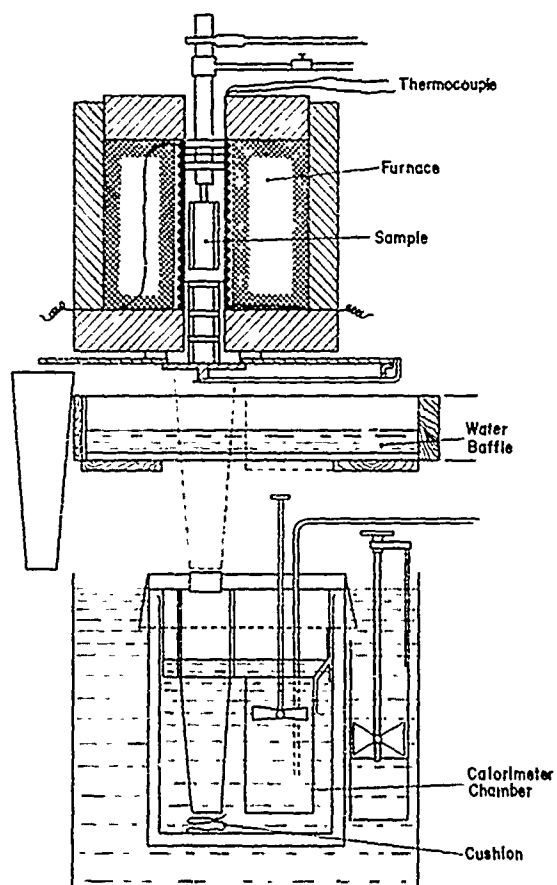

Fig. 4. Schematic diagram for drop isothermal water calorimeter [50].

proper, which consists of a water bath with free air space above. The water in the bath is stirred to assure uniform temperature. The calorimeter is enclosed by an isothermal jacket and the top is covered with copper plates which have a constant temperature because of their high thermal conductivity. The rise in the temperature of the calorimeter is measured with great accuracy by using a Beckmann thermometer or a sensitive thermopile. The enthalpy change of the specimen is determined from the known heat capacity of the calorimeter and its temperature rise. The enthalpy change may be referred to either 273.15 K or 298.15 K. In either case the specific heat is obtained from the smoothed enthalpy data by either graphical or analytical differentiation, i.e.,

$$C_p = \frac{d(H_T - H_{298.15})_p}{dT}$$

A schematic drawing [50] is shown in Fig. 4 to illustrate the details of the apparatus.

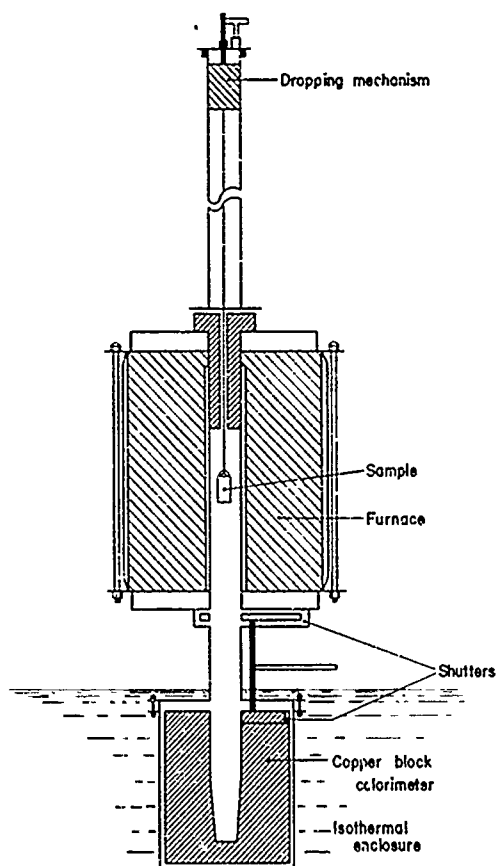

Fig. 5. Schematic diagram for drop isothermal copper block calorimeter [37].

6. DROP COPPER BLOCK CALORIMETER

This drop calorimeter employs a copper block which is submerged in an isothermal oil bath. The temperature of the calorimeter is measured using a special bridge network of copper and manganin resistances. The heat released from the sample is distributed to the copper block because of its high thermal conductivity. Generally it takes some time to achieve uniform heat distribution. The change in enthalpy of the specimen is measured in terms of the amount of heat absorbed by the copper block in changing from its initial temperature to its final temperature. This value is then corrected to 298.15 K so that the tabulated enthalpy values of the specimen are referred to 298.15 K, that is, $H_T - H_{298.15}$. The specific heat as a function of temperature may then be derived from the smoothed enthalpy data obtained either graphically or from the equation

$$C_p = \frac{d}{dT}(H_T - H_{298.15})_r$$

A schematic diagram according to Southard [37] is shown in Fig. 5.

7. PULSE-HEATING METHOD

The pulse-heating method of measuring specific heat is very attractive, particularly for materials that are electrical conductors. This method was first discussed by Avramescu [1] and later modified by other investigators [2, 25, 39, 41]. The method involves the rapid heating of small samples in vacuum. Voltage probes are attached across the central portion of the sample wire which is then mounted in a high-vacuum system. The sample is connected to an electrical circuit consisting of a large storage battery, a variable resistor, a fixed resistor, and a high-current relay controlled by a timing circuit which determines the duration of the pulse. A schematic diagram of a typical circuit [41] for the measurement of specific heat is shown in Fig. 6. The current flowing through the specimen and the voltage drop across the central portion are measured simultaneously as a function of time. The specific resistance at each time interval is calculated from the relationship $\rho = AE/LI$, where A is the cross-sectional area of sample, E is the voltage, I is the current, and L is the distance between voltage probes. This specific electrical resistance is then plotted as a function of time. The specific heat at any temperature T is given by the equation

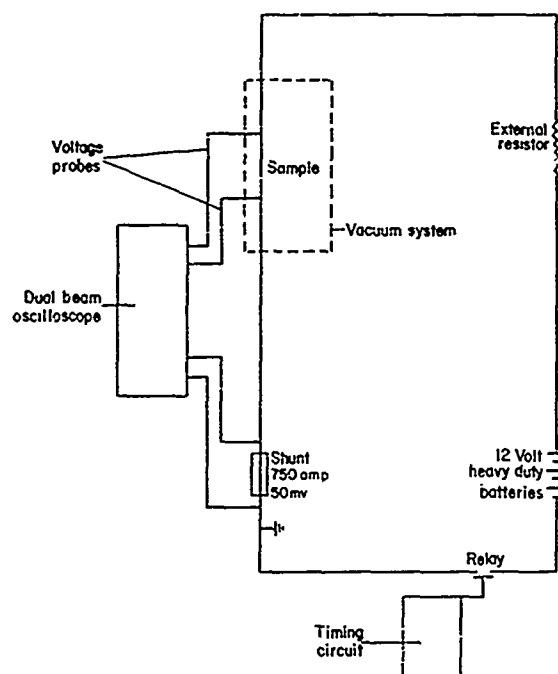

Fig. 6. Schematic diagram of circuit for specific heat measurement using pulse-heating method [41].

$$C_p = \frac{EI(d\rho/dT)}{Jm(d\rho/dt)} \quad (47)$$

where C_p is the specific heat, $\text{cal g}^{-1} \text{K}^{-1}$, J is the conversion factor, $4.184 \text{ joules cal}^{-1}$, m is the mass of sample between voltage probes, grams, $d\rho/dT$ is the

temperature coefficient of the resistance at temperature T , $d\rho/dt$ is the time rate of change of resistivity at temperature T , and ρ is the electrical resistivity of sample.

8. COMPARATIVE METHOD

The method consists of placing a specimen with its temperature-monitoring thermocouple in a refractory container of low thermal conductivity and in turn placing this in a furnace whose temperature is maintained constant above or below the specimen temperature. The container is calibrated by determining its heating rate when empty and then with a reference sample of known specific heat. Separate electrical heating circuits are usually provided for the specimen and the shield so that their temperature will rise equally and simultaneously in order to reduce heat losses. The specific heat C_{p2} of the unknown specimen is calculated from the following relation:

$$\frac{C_{p2}W_2}{C_{p1}W_1} = \frac{\Delta t_2/\Delta T_2 - \Delta t_r/\Delta T_r}{\Delta t_1/\Delta T_1 - \Delta t_r/\Delta T_r} \quad (48)$$

where $(\Delta t/\Delta T)$ is the slope of a time-temperature curve, and the subscripts r , 1, and 2 represent the empty container, the container with specimen 1, and the container with specimen 2, respectively. The papers by Boggs and Wiebelt [3] and Smith [34] give excellent accounts in the use of this method.

Irreproducible heating or cooling conditions and differences in thermal conductivity between the unknown and reference specimen usually account for the inaccuracies encountered in this method.

References to Text

1. Aramescu, A., "Temperature Variation of the True Specific Heat of Conductivity Copper and Conductivity Aluminum up to the Melting Point," *Z. Tech. Physik* 20, 213-17, 1939.
2. Baxter, H., "Determination of Specific Heat of Metals," *Nature* 153, 316, 1944.
3. Boggs, J. H. and Wiebelt, J. A., "An Investigation of a Particular Comparative Method of Specific Heat Determination in the Temperature Range of 1500 F to 2600 F," USAEC TID-5734, 1-91, 1960.
4. Born, M. and Karman, T., "Vibrations in Space Lattices," *Physik Z.* 13, 297-309, 1912.
5. Bottema, J. A. and Jaeger, F. M., "The Law of Additive Atomic Heats in Intermetallic Compounds," *Proc. Acad. Sci. Amsterdam* 35, 928-31, 1932.
6. Debye, P., "The Theory of Specific Heat," *Ann. Physik* 39 (4), 789-839, 1912.
7. Dekker, A. J., *Solid State Physics*, Prentice-Hall, Inc., 1-525, 1961.
8. Drude, P., "The Electronic Theory of Metal," *Ann. Physik* 1, 566-613, 1900.
9. Dulong, P. L. and Petit, A. T., *Ann. Chim.* 10, 395-413, 1819.
10. Einstein, A., "The Planck's Theory of Radiation and the Theory of Specific Heat," *Ann. Physik* 22 (4), 180-90, 1907.
11. Eldridge, E. A. and Deem, H. W., "Report on Physical Properties of Metals and Alloys from Cryogenic to Elevated Temperatures," ASTM-ST-296, 1-206, 1961.
12. Furukawa, G. T., Saba, W. G., and Reilly, M. L., "Critical Analysis of the Heat-Capacity Data of the Literature and Evaluation of Thermodynamic Properties of Copper, Silver, and Gold from 0 to 300 K," NSRDS-NBS 18, 1-49, 1968.
13. Ginnings, D. C. and Corruccini, R. J., "An Improved Ice Calorimeter—The Determination of its Calibration Factor and the Density of Ice at 0 C," *J. Res. Natl. Bur. Std.* 38, 583-91, 1947.
14. Ginnings, D. C. and Furukawa, G. T., "Heat Capacity Standards for the Range 14 to 1200 K," *J. Am. Chem. Soc.* 75, 522-7, 1953.
15. Gopal, E. S. R., *Specific Heats at Low Temperatures*, Plenum Press, 1-111, 1966.
16. Hultgren, R., Orr, R. L., Anderson, P. D., and Kelley, K. K., *Selected Values of Thermodynamic Properties of Metals and Alloys*, John Wiley and Sons, Inc., 1-963, 1963.
17. Johnson, V. J. (Editor), "A Compendium of the Properties of Materials at Low Temperature," WADD-TR-60-56, Pt. 2, 1-333, 1960. [AD 249 786]
18. Kelley, K. K., "Data on Theoretical Metallurgy. XIII. High-Temperature Heat Capacity and Entropy Data for the Elements and Inorganic Compounds," U.S. Bur. Mines Bull. 584, 1-232, 1960.
19. King, A. L., *Thermophysics*, W. H. Freeman and Company, 1-369, 1962.
20. Kittel, C., *Introduction to Solid State Physics*, John Wiley and Sons, Inc., 122-5, 1963.
21. Kittel, C., *Elementary Solid State Physics*, John Wiley and Sons, Inc., 49-52, 1962.
22. Lehman, G. W., "Thermal Properties of Refractory Materials," WADD-TR-60-581, 1-19, 1960. [AD 247 411], [PB 160 804]
23. Levinson, L. S., "High Temperature Drop Calorimeter," *Rev. Sci. Instr.* 36 (6), 639-42, 1962.
24. Moeller, C. E., Loser, J. B., Thompson, M. B., Snyder, W. E., and Hopkins, V., "Thermophysical Properties of Thermal Insulating Materials," ASD-TDR-64-5, 1-362, 1964. [AD 601 535], [N64 22689]
25. Nathan, A. M., "A Dynamic Method for Measuring the Specific Heat of Metals," *J. Appl. Phys.* 22, 234-5, 1951.
26. Parker, W. J., Jenkins, R. J., Butler, C. P., and Abbott, G. L., "Flash Method of Determining Thermal Diffusivity, Heat Capacity and Thermal Conductivity," *J. Appl. Phys.* 32, 1679-84, 1961.
27. Reif, F., *Fundamentals of Statistical and Thermal Physics*, McGraw-Hill Book Co., Inc., 1-651, 1965.
28. Sachs, M., *Solid State Theory*, McGraw-Hill Book Co., Inc., 143-68, 1963.
29. Schick, H. L. (Editor), *Thermodynamics of Certain Refractory Compounds, Vol. 2*, Academic Press, 1-775, 1966.
30. Schmidt, E. O. and Leidenfrost, W., "Adiabatic Calorimeter for Measurements of Specific Heats of Powder and Granular Materials at 0 C to 500 C," *ASME 2nd Symp. Thermophysical Properties*, Princeton, N.J., 178-84, 1962.
31. Sears, F. W., *An Introduction to Thermodynamics, The Kinetic Theory of Gases, and Statistical Mechanics*, Addison-Wesley Publishing Co., Inc., 1-373, 1964.
32. Seitz, F., *The Modern Theory of Solids*, McGraw-Hill Book Co., Inc., 38-9, 1940.
33. Slater, J. C., *Introduction to Chemical Physics*, McGraw-Hill Book Co., Inc., 1939.
34. Smith, C. S., "A Simple Method for Thermal Analysis Permitting Quantitative Measurements of Specific and Latent Heats," *Trans. AIME* 137, 1936, 1940.
35. Smith, D. F., Kaylor, C. E., Walden, G. E., Taylor, A. R., and Gayle, J. B., "Construction, Calibration and Operation of Ice Calorimeter," U.S. Bur. Mines Rept. Invest. 5832, 1-20, 1961.

36. Sommerfeld, A., "The Electronic Theory of Metals," *Naturwiss* 15, 825-32, 1927.
37. Southard, J. C., "A Modified Calorimeter for High Temperatures. The Heat Content of Silica, Wollastonite, and Thorium Dioxide above 25°," *J. Am. Chem. Soc.* 63, 3142-6, 1941.
38. Sterrett, K. F., Blackburn, D. A., Bestul, A. B., Chang, S. S., and Horman, J., "An Adiabatic Calorimeter for the Range 10 K to 360 K," *J. Res. Natl. Bur. Std.* 69C, 19-26, 1965.
39. Strittmater, R. C., Pearson, G. J., and Danielson, G. C., "Measurements of Specific Heats by a Pulse Method," *Proc. Iowa Acad. Sci.* 64, 466-70, 1957.
40. Stull, D. R. and Sinke, G. C., *Thermodynamic Properties of the Elements*, Am. Chem. Soc., 1-234, 1956.
41. Taylor, R. E. and Finch, R. A., "The Specific Heats and Resistivities of Molybdenum, Tantalum, and Rhenium," *J. Less-Common Metals* 6, 283-94, 1964.
42. Taylor, A. R. and Smith, D. F., "Construction, Calibration, and Operation of a Low-Temperature Adiabatic Calorimeter," U.S. Bur. Mines Rept. Invest. 5974, 1-17, 1962.
43. Tolman, R. C., *Principles of Statistical Mechanics*, Oxford Univ. Press, London, 1938.
44. Touloukian, Y. S. (Editor), *Thermophysical Properties of High Temperature Solid Materials*, MacMillan Co., Vols. 1, 2, 3, 4, 5, and 6, 1-8500, 1967.
45. Touloukian, Y. S., Gerritsen, J. K., and Moore, N. Y., *Thermophysical Properties Research Literature Retrieval Guide*, Plenum Press, 2nd Ed., Books 1, 2, and 3, 1967.
46. Touloukian, Y. S. (Editor), "Recommended Values of the Thermophysical Properties of Eight Alloys, Major Constituents and Their Oxides," TPRC Rept. 16, 323-46, 1966.
47. Wallace, W. E., Craig, R. S., and Johnston, W. V., "An Adiabatic Calorimeter for the Range 15 C to 290 C," U.S. At. Energy Comm., NYD-6328, 1-16, 1966.
48. Weber, H. F., "The Specific Heat of Elements Carbon, Boron, and Silicon," *Phil. Mag.* 49, 161-301, 1875.
49. Westrum, E. F., Jr., "Cryogenic Calorimetric Contributions to Chemical Thermodynamics," *J. Chem. Educ.* 39 (9), 443-54, 1962.
50. White, W. P., "Specific Heat Determination at Higher Temperatures," *Am. J. Sci.* 47 (4), 1-59, 1919.
51. Whittaker, E. T. and Watson, G. N., *Modern Analysis*, Cambridge Univ. Press, 4th edition, 1938.
52. Wood, W. D. and Deem, H. W., "Thermal Properties of High-Temperature Materials," RSIC-202, 1-399, 1964. [AD 455 069]
53. Zemansky, M. W., *Heat and Thermodynamics*, McGraw-Hill Book Co., Inc., 1-484, 1957.
54. McCullough, J. P. and Scott, D. W. (Editors), *Experimental Thermodynamics, Volume I, Calorimetry of Non-Reacting Systems*, Plenum Press (New York)/Butterworths (London), 1968.
55. White, W. P., *The Modern Calorimeter*, Chemical Catalog Co., New York, 1928.
56. Swietoslowski, W., *Microcalorimetry*, Reinhold, New York, 1964.
57. Calvet, E. and Prat, H., *Microcalorimétrie*, Masson et Cie, Paris, 1956.
58. Roth, W. A. and Becker, F., *Kalorimetrische Methoden zur Bestimmung chemischer Reaktionswärmen*, F. Vieweg, Braunschweig, 1956.
59. Rossini, F. D. (Editor), *Experimental Thermochemistry*, Vol. I, Interscience, New York, 1956.
60. Weissberger, A. (Editor), "Calorimetry" in *Technique of Organic Chemistry Vol. I. Physical Methods of Organic Chemistry*, Chap. X, Interscience, New York, 1959.
61. Skinner, H. A. (Editor), *Experimental Thermochemistry*, Vol. II, Interscience, London, 1962.

Numerical Data

Data Presentation and Related General Information

1. SCOPE OF COVERAGE

The materials studied in this volume consist of nonmetallic elements, oxides, and other nonmetallic compounds and mixtures. The nonmetallic elements and compounds are listed in the table of contents in alphabetical order according to chemical name. The data presented are original experimental data on the specific heat of these materials as reported by various investigators. These data were extracted from the world's technical and scientific literature, United States Government Publications, Doctoral and Masters dissertations, data supplied by private companies, and special reports of major research centers throughout the world. The range of temperatures covered is from zero degree Kelvin to the melting point and beyond. For most high-temperature materials, no information is found in the liquid range.

2. PRESENTATION OF DATA

The data for all substances are presented in graphical and tabular form together with a specification table for each substance. The specification table gives the temperature range, the original reference number, the curve number, reported estimates of error, year of publication of the original document, specimen designation, and such other pertinent information as composition or purity of sample, test environment, mechanical, chemical, and thermal history of the test specimen, etc., to the extent provided in the original source document. The data for the specific heat of the materials are plotted on a log-log scale for comparative evaluation. When several sets of data are coincident, the graphical plotting of all of them would lead to confusion. For this reason, some of the sets of data points are omitted from the figures. They are, however, reported in the data tables and specification tables.

The numerical data are presented in double columns. The temperature T is in degrees Kelvin, and the specific heat C_p in calories per gram per degree Kelvin. A unique curve number is assigned to each set of data. This corresponds exactly to the number which also appears in the specification table and on the figure.

The two general types of data that are obtainable from the literature are the true specific heat data obtained directly from the results of measurements using, for instance, the Nernst-type calorimeter and the derived true specific heat data, deduced from direct enthalpy measurements using the drop technique. In the latter type an empirical equation has been fitted by the authors to the enthalpy data by least squares technique and specific heat obtained by differentiation. The results are usually tabulated at rounded temperature intervals.

3. SYMBOLS AND ABBREVIATIONS USED IN THE FIGURES AND TABLES

<i>Symbol</i>	<i>Definition</i>	<i>Units</i>
T	Temperature	degree Kelvin, K
C_p	Constant pressure specific heat	$\text{cal g}^{-1} \text{K}^{-1}$
C_v	Constant volume specific heat	$\text{cal g}^{-1} \text{K}^{-1}$
M. P.	Melting point	degree Kelvin, K
T. P.	Transition point	degree Kelvin, K
s. c.	Superconducting	
N	Normal	
c	Cubic	
f.c.c.	Face-centered cubic	
b.c.c.	Body-centered cubic	
h	Hexagonal	
c.p.h.	Close-packed hexagonal	

CONVERSION FACTORS FOR UNITS OF SPECIFIC HEAT

MULTIPLY by appropriate factor to OBTAIN →	$\text{cal}_{\text{th}} \text{ g-mol}^{-1} \text{ C}^{-1}$	$\text{cal}_{\text{th}} \text{ g}^{-1} \text{ C}^{-1}$	$\text{cal}_{\text{th}} \text{ g-mol}^{-1} \text{ C}^{-1}$	$\text{cal}_{\text{th}} \text{ g}^{-1} \text{ C}^{-1}$	$\text{cal}_{\text{IT}} \text{ g-mol}^{-1} \text{ C}^{-1}$	$\text{cal}_{\text{IT}} \text{ g}^{-1} \text{ C}^{-1}$	$\text{cal}_{\text{IT}} \text{ g}^{-1} \text{ C}^{-1}$	$\text{J g-mol}^{-1} \text{ K}^{-1}$	$\text{J g}^{-1} \text{ K}^{-1}$	$\text{J kg-mol}^{-1} \text{ K}^{-1}$	$\text{J kg}^{-1} \text{ K}^{-1}$	$\text{Btu}_{\text{th}} \text{ lb}^{-1} \text{ F}^{-1}$	$\text{Btu}_{\text{th}} \text{ lb}^{-1} \text{ F}^{-1}$	$\text{Btu}_{\text{IT}} \text{ lb}^{-1} \text{ F}^{-1}$
$\text{cal}_{\text{th}} \text{ g-mol}^{-1} \text{ C}^{-1}$	1	1/M	0.999331	0.999331/M	0.999331	0.999331/M	4.184	4.184/M	4.184 × 10 ³	4.184/M × 10 ³	1/M	1	1/M	0.999331/M
$\text{cal}_{\text{th}} \text{ g}^{-1} \text{ C}^{-1}$	M	1	0.999331M	0.999331	0.999331M	0.999331	4.184M	4.184	4.184 × 10 ³	4.184M × 10 ³	1	1	1	0.999331
$\text{cal}_{\text{IT}} \text{ g-mol}^{-1} \text{ C}^{-1}$	1.00067	1.00067/M	1	1/M	1/M	1	4.1868	4.1868/M	4.1868 × 10 ³	(4.1868/M) × 10 ³	1.00067/M	1.00067/M	1.00067/M	1/M
$\text{cal}_{\text{IT}} \text{ g}^{-1} \text{ C}^{-1}$	1.00067M	1.00067	M	1	1	1	4.1868M	4.1868	4.1868 × 10 ³	4.1868M × 10 ³	1.00067	1.00067	1.00067	1
$\text{J g-mol}^{-1} \text{ K}^{-1}$	0.239006	0.239006/M	0.238846	0.238846/M	0.238846	0.238846/M	1	1/M	1 × 10 ³	1 × 10 ³ /M	0.239006/M	0.239006/M	0.239006/M	0.238846/M
$\text{J g}^{-1} \text{ K}^{-1}$	0.239006M	0.239006	0.238846M	0.238846	0.238846M	0.238846	M	1	M × 10 ³	10 ³	10 ³	0.239006	0.239006	0.238846
$\text{J kg-mol}^{-1} \text{ K}^{-1}$	2.39006 × 10 ⁻⁴	(2.39006/M) × 10 ⁻⁴	2.38846 × 10 ⁻⁴	(2.38846/M) × 10 ⁻⁴	2.38846 × 10 ⁻⁴	(2.38846/M) × 10 ⁻⁴	10 ⁻³	10 ⁻³ /M	1	1/M	1/M	(2.39006/M) × 10 ⁻¹	(2.39006/M) × 10 ⁻¹	(2.38846/M) × 10 ⁻¹
$\text{J kg}^{-1} \text{ K}^{-1}$	2.39006M × 10 ⁻⁴	2.39006 × 10 ⁻⁴	2.38846M × 10 ⁻⁴	2.38846 × 10 ⁻⁴	2.38846M × 10 ⁻⁴	2.38846 × 10 ⁻⁴	M × 10 ⁻³	10 ⁻³	M	M	1	2.39006 × 10 ⁻¹	2.39006 × 10 ⁻¹	2.38846 × 10 ⁻¹
$\text{Btu}_{\text{th}} \text{ lb}^{-1} \text{ F}^{-1}$	M	1	0.999331M	0.999331	0.999331M	0.999331	4.184M	4.184	4.184 × 10 ³	4.184M × 10 ³	1	1	1	0.999331
$\text{Btu}_{\text{IT}} \text{ lb}^{-1} \text{ F}^{-1}$	1.00067M	1.00067	M	1	1	1	4.1868M	4.1868	4.1868 × 10 ³	4.1868M × 10 ³	1.00067	1.00067	1.00067	1

Classification of Materials

Classification	Limits of composition (weight percent)*			
	X ₁	X ₁ + X ₂	X ₂	X ₃
1. Nonmetallic elements	>99.5	—	<0.2	<0.2
2. Compounds	>95.0	—	<2.0	<2.0
3. Binary mixtures (or solutions)	—	≥95.0	≥2.0	≤2.0
4. Multiple mixtures (or solutions)	—	≥95.0	>2.0	>2.0
	—	<95.0	≥2.0	≤2.0
	—	<95.0	>2.0	>2.0
	≤95.0	—	<2.0	<2.0

*X₁ ≥ X₂ ≥ X₃ ≥ X₄ ≥

4. CONVERSION FACTOR FOR UNITS OF SPECIFIC HEAT

The conversion factors given in the table on page 20a are based upon the following basic definitions:

$$\begin{aligned}
 1 \text{ lb} &= 0.45359237 \text{ kg}^* \\
 1 \text{ cal}_{\text{th}} &= 4.184 \text{ (exactly) J}^* \\
 1 \text{ cal}_{\text{IT}} &= 4.1868 \text{ (exactly) J}^* \\
 1 \text{ Btu}_{\text{th}} \text{ lb}^{-1} \text{ F}^{-1} &= 1 \text{ cal}_{\text{th}} \text{ g}^{-1} \text{ C}^{-1} \dagger \\
 1 \text{ Btu}_{\text{IT}} \text{ lb}^{-1} \text{ F}^{-1} &= 1 \text{ cal}_{\text{IT}} \text{ g}^{-1} \text{ C}^{-1} \dagger
 \end{aligned}$$

The subscripts "th" and "IT" designate "thermochemical" and "International Steam Table," respectively.

5. CLASSIFICATION OF MATERIALS

The classification scheme as shown in the table for nonmetallic solids contained in this volume is based upon the chemical composition of the material. This scheme is mainly for the convenience of material grouping and data organization, and is not intended to be used as definitions for the various material groups.

6. CONVENTION FOR BIBLIOGRAPHIC CITATION

For the following types of documents the

*National Bureau of Standards, "New Values for the Physical Constants Recommended by NAS-NRC," *NBS Tech. News Bull.* 47(10), 175-7, 1963.

†Mueller, E. F. and Rossini, F. D., "The Calory and the Joule in Thermodynamics and Thermochemistry," *Am. J. Phys.* 12(1), 1-7, 1944.

bibliographic information is cited in the sequences given below.

Journal Article:

- Author(s)—The names and initials of all authors are given. The last name is written first, followed by initials.
- Title of article—In this volume, the titles of the journal articles listed in the *References to Text* are given, but not of those listed in the *References to Data Sources*.
- Journal title—The abbreviated title of the journal as in *Chemical Abstracts* is given.
- Series, volume, and number—If the series is designated by a letter, no comma is used between the letter for series and the numeral for volume, and they are underlined together. In case series is also designated by a numeral, a comma is used between the numeral for series and the numeral for volume, and only the numeral representing volume is underlined. No comma is used between the numerals representing volume and number. The numeral for number is enclosed in parentheses.
- Pages—The inclusive page numbers of the article.
- Year—The year of publication.

Report:

- Author(s).
- Title of report—In this volume, the titles of the reports listed in the *References to Text* are given, but not of those listed in the *References to Data Sources*.
- Name of the responsible organization.
- Report, or bulletin, circular, technical note, etc.
- Number

- f. Part
- g. Pages
- h. Year
- i. ASTIA's AD number—This is given in square brackets whenever available.

Book:

- a. Author(s)
- b. Title
- c. Volume
- d. Edition
- e. Publisher
- f. Place of publication
- g. Pages
- h. Year.

7. CRYSTAL STRUCTURES, TRANSITION TEMPERATURES, AND OTHER PERTINENT PHYSICAL CONSTANTS OF THE ELEMENTS

The table on the following pages contains information on the crystal structure, transition temperatures, and certain other pertinent physical constants of each element. This information is very useful in data analysis and synthesis. However, no attempt has been made to critically evaluate the temperatures/constants given in the table and they should not be considered recommended values. This table has an independent series of numbered references which immediately follow the table.

CRYSTAL STRUCTURES, TRANSITION TEMPERATURES, AND OTHER PERTINENT PHYSICAL CONSTANTS OF THE ELEMENTS

Name	Atomic Number	Atomic Weight ^a	Density, ^b kgm. ⁻³ · 10 ⁻³	Crystal Structure	Phase Transition Temp., K	Superconducting Temp., K	Debye Temperature at 0 K, K		Melting Point, K		Boiling Point, K		Critical Temp., K
							K	K	K	K	K	K	
Actinium	89	(227)	10.07 ¹⁰	f. c. c. ²			124 ³	100 ⁴ (at ~50 K)	1323 ⁵	3200 ± 300 ⁶			
Aluminum	13	26.9815	2.702 ⁵	f. c. c. ⁷		1.196 ⁵ 1.17 ⁸ 1.18 ⁹	423 ± 5 ³	390 ³	933.2 ^{3,10}	2723 ^{3,10}		8650 ¹¹ 7740 ¹⁰	
Americium	95	(243)	11.7 ⁵	Double c. p. h. ²			150 ³	200 ¹⁴	1473 ²⁵	2880 ¹⁰⁸			
Antimony	51	121.75	6.684 ²⁸	r. ² (?)	367.8 (γ-?) ¹⁵	2.6 (Sb II, high-pressure modification) ⁹	903.7 ¹³	903.65 ²³	1907 ± 10 ²	2989 ¹⁵			
Argon	18	39.948	0.0017824 ²⁹ (at 273.2 K and 1 atm)	? (?)	690 ¹³ (?)			83.8 ¹⁷	87.29 ¹³	151 ¹⁵			
Arsenic	33	74.9216	5.73 (gray, at 287.2 K) ²⁹ 4.7 (black) ²⁹ 2.0 (yellow) ²⁹	r. ⁷ (gray) c. (yellow)	?		236 ³	275 ¹⁸	1090 ¹³ (35.8 atm) (35.8 atm) sublim. 856 ⁹	1090 ¹³			
Astatine	85	(210)							573.2 ¹⁹	650 ²⁰			
Barium	56	137.34	3.5 ²⁹	b. c. c. (α) ¹³ ? (β)	648 ^{13,21} (α-β)		110.5 ± 1.8 ²²	116 ¹¹⁶	998.2 ⁵	1910 ³		3663 ¹⁰ 3920 ¹⁰	
Berkelium	97	(249)							1550 ²⁸	3142 ± 100 ³		6153 ¹⁵	
Beryllium	4	9.0122	1.85 ²⁹	c. p. h. ² (α) b. c. c. (β)	1533 ²⁴ (α-β)	~6 ¹⁰⁸ ~8.4 ¹⁰⁶	1160 ²⁵	1031 ³					
Bismuth	83	208.980	9.78 ²⁹	r. ²	3.9 (Bi II, at 2.5 kbar) ⁹ 7.2 (Bi III, at 27 kbar) ⁹		119 ± 2 ³	116 ± 5 ¹	544.525 ^{3,111}	1824 ± 8 ³		4620 ²¹	
Boron	5	10.811	2.50 ⁴²	Simple r. ² (α) t. (β)	1473 (α-β) ²		1315 ⁵³	1362 ³	2573 ⁵	4050 ± 100 ³⁰			
Bromine	35	79.903	3.119 ²⁹	orthorh. ⁸					266.0 ¹⁷	331.93 ²⁹		584 ¹⁵	

^a Atomic weights are based on ¹²C = 12 as adopted by the International Union of Pure and Applied Chemistry in 1961; those in parentheses are the mass numbers of the isotopes of longest known half-life.
^b Density values are given at 293.2 K unless otherwise noted.
^c Superscript numbers designate references listed at the end of the table.

Name	Atomic Number	Atomic Weight ^a	Density, ^b kgm ⁻³ · 10 ⁻³	Crystal Structure	Phase Transition Temp., K	Superconducting		Néel Temp., K	Debye Temperature at 0 K, K	Melting Point, K	Boiling Point, K	Critical Temp., K
						Transition Temp., K	Curie Temp., K					
Cadmium	48	112.40	8.65 ²³	c.p.h. ² b.c.c. ⁴ (γ)		0.56 ⁵ 0.52 ⁹		252 ± 48 ³	221 ³ 170 (b.c.c., Subl. ¹³ at ~85 K)	594.16 ^{3,10} 594.1 ¹³ (at 0.11 mm Hg)	1038 ³	1903 ¹⁵ 3560 ¹⁰⁹
Calcium	20	40.08	1.55 ²⁹	f.c.c. ⁷ (α) b.c.c. ¹ (β)	737 ⁶² (α-β)			234 ± 5 ³	280 ³	1123 ¹⁹ 1123 ¹³ (at 0.35 mm Hg)	1765 ³	3267 ¹⁵
Californium	98	(251)										
Carbon (amorphous)	6	12.01115	1.8~2.1 ²⁹					240 ± 5 ³¹	1874 ³	Subl. ⁵ 3925-3970 ⁵	5100 ⁵	4473 ⁵
Carbon (diamond)	6	12.01115	3.51 ²⁹	d. ¹⁸				402 ± 11 ³	1550 ³	Subl. ⁵ 3925-3970 ⁵	4473 ⁵	
Carbon (graphite)	6	12.01115	2.26 ²⁹ (α)	h. ² (α) r. ¹ (β)				146 ³	198 ³⁴	1077 ²⁶	3972 ³	10400 ¹⁰⁹
Cerium	58	140.12	6.90 ²⁹	f.c.c. ³² (α) Double c.p.h. ² (β) f.c.c. ³² (γ) b.c.c. ³² (δ) b.c.c. ²	103 ± 5 ³² (α-β) 263 ± 5 ³² (β-γ) 1003 ³² (γ-δ)			1 ³²				
Cesium	55	132.905	1.873 ²⁹	b.c.c. ²				40 ± 5 ³	43 ³³	301.9 ²⁹ Subl. ¹⁹ 301.9 ¹⁹ (at 1.2 μHg)	939 ³⁵	115,116,118 ¹⁵ 2060 ¹⁰⁹ 1900 ¹⁰⁹
Chlorine	17	35.453	0.003214 ²⁹ (at 273.2 K)	t. ¹⁶								
Chromium	24	51.996	7.16 ⁴²	c.p.h. ^{17,d} (α) b.c.c. ¹ (β)	~299 ¹⁷ (α-β) ^d			598 ± 32 ³	424 ³	2118 ³³	2918 ± 35 ³	
Cobalt	27	58.9332	8.862 ⁴²	c.p.h. ¹⁷ (α) f.c.c. ¹⁷ (β) f.c.c. ²	690 ³² (α-β)			452 ± 17 ³	386 ³	1765 ^{3,10}	3223 ³	
Copper	29	63.54	8.933 ²⁹	f.c.c. ²				342 ± 2 ³	310 ³	1356 ^{3,10}	2811 ± 20 ⁴¹	8500 ¹¹ 8280 ¹⁰⁹
Curium	96	(247)	7 ⁴²	Double c.p.h. ³								
Dysprosium	66	162.50	8.556 ⁴²	c.p.h. ² (α) b.c.c. ¹ (β)	Near m.p. ² (α-β)			172 ± 35 ³	158 ⁴⁴	177 ¹²	3011 ⁴⁴	7640 ¹⁰⁹

^d Close-packed hexagonal crystalline modification of chromium may be formed by electrodeposition below 293 K under special conditions of deposition process. This c.p.h. form is unstable and will irreversibly transform into b.c.c. form on heating.

(ferroc-antiferromag.)

Name	Atomic Number	Atomic Weight	Density, ^b kg m ⁻³ · 10 ⁻³	Crystal Structure	Phase Transition Temp., ^c K	Superconducting Transition Temp., ^d K	Curie Temp., ^e K	Nel Temp., ^f K	Debye Temperature at 0 K, ^g K	Debye Temperature at 298 K, ^h K	Melting Point, ⁱ K	Boiling Point, ^j K	Critical Temp., ^k K
Einsteinium	99	(254)											
Erbium	68	167.26	9.06 ⁴²	c. p. h. (α) b. c. c. (β)	1643 ² (α-β)		19 ⁴	80 ⁴	134 ± 10 ⁴⁵	163 ⁴⁴	1770 ²⁶	3000 ³	7250 ¹⁰⁹
Europtium	63	151.96	5.245 ²³	b. c. c. ⁷				~90 ⁴	127 ³		1099 ⁵	1971 ⁴⁶	4600 ¹⁰⁹
Fermium	100	(253)											
Fluorine	9	18.9984	0.001695 ²⁹ (at 273.2 K and 1 atm)	c. (β-F ₂)							53.58 ⁵	85.24 ¹⁵	14.4 ¹⁵
Francium	87	(223)							39 ³		300.2 ¹⁹	879 ¹⁰⁹	
Gadolinium	64	157.25	7.87 ⁴²	c. p. h. (α) b. c. c. (β)	1535 ³² (α-β)		292 ⁴⁰		170 ³	155 ± 3 ³	1579 ¹⁹	3540 ³	8070 ¹⁰⁹
Gallium	31	69.72	5.91 ²³	orthorh. (α) t. (β)	275.6 ¹³ (α-β) (at 8.86 × 10 ⁶ mm Hg)	1.091 ⁵ 7.2 ³⁵ (Ga II, high-pressure modification)			317 ³	240 ¹⁴ (total at ~63 K)	302.93 ⁶ 275.6 ¹⁹ (at 8.86 × 10 ⁶ mm Hg)	2510 ³	7620 ²⁷
Germanium	32	72.59	5.36 ²³	d. ⁷		5.5 ⁴⁷ (at ~118 kbar) 8-10 ⁸			378 ± 22 ³	403 ²	1210.6 ⁵	3100 ³	5642 ¹⁵
Gold	79	196.967	19.3 ⁴²	f. c. c. ⁷					165 ± 1 ³	178 ± 8 ³	1336.2 ^{5,10} 1336.15 ²³	3240 ³	6500 ¹¹ 8060 ¹⁰⁹
Hafnium	72	178.49	13.28 ⁴²	c. p. h. (α) b. c. c. (β)	2023 ± 20 ⁴⁵ (α-β)	0.16 ⁹ 0.35 ¹⁰⁸			256 ± 5 ³	213 ²³	2495 ¹⁹	4575 ± 150 ⁴⁷	
Helium	2	4.0026	0.0001785 ²³ (at 273.2 K and 1 atm)	c. p. h. ¹⁶						30 ⁴ (at ~45 K)	3.45 ²⁷ 1.8 ± 0.2 ¹⁷ (at 30 atm)	4.216 ¹³ 4.22 ²³	5.3 ¹³
Holmium	67	164.930	8.80 ²³	c. p. h. (α) b. c. c. (β)	Near m. p. (α-β)		20 ⁴	132 ⁴	114 ± 7 ⁴⁵	161 ⁴⁴	1794 ¹⁹	3228 ⁵¹	
Hydrogen	1	1.00797	0.0000987 ²⁹ (at 273.2 K and 1 atm)	c. p. h. ¹⁶							116 (para., 13.8 ± 0.1 ¹⁷ at ~68 K) 105 (ortho., at ~53 K)	20.39 ¹³ 20.37 ²³	33.3 ¹⁵
Indium	49	114.82	7.3 ²³	f. c. t. ⁷		3.4035 ⁵			108.8 ± 0.3 ³	129 ¹⁴	423.76 ^{3,110}	2279 ± 6 ³	4377 ¹⁵ 7050 ¹⁰⁹
Iodine	53	126.9044	4.53 ²³	orthorh. ¹⁶						105 ⁴ (at ~53 K) subl. 298.16 ¹³ (at 0.31 mm Hg)	386.8 ²⁹ 386.8 ¹³	457.50 ¹⁵	785 ¹⁵
Iridium	77	192.2	22.5 ⁴²	f. c. c. ⁷		0.14 ^{5,9}			425 ± 5 ³	228 ³	2716 ^{3,10}	4820 ± 30 ³	

Name	Atomic Number	Atomic Weight ^a	Density, ^b kg m ⁻³ · 10 ⁻³	Crystal Structure	Phase Transition Temp., K	Superconducting		Néel Temp., K	Debye Temperature, at 0 K, K	Melting Point, K	Boiling Point, K	Critical Temp., K
						Transition Temp., K	Transition Temp., K					
Neptunium	93	(237)	20.46 ⁴²	orthorh. (α) t. (β) b. c. c. (γ) f. c. c.	551 ² (α-β) 813 ² (β-γ)	9.13 ⁵ 9.09 ⁸ 9.1 ⁹	631 ⁴⁰	121 ³	163 ³	913.2 ¹	4150 ³	
Nickel	28	58.71	8.90 ⁴²	b. c. c. (γ) f. c. c.				427 ± 14 ³	345 ³	1726 ^{3,10} 1726 ± 4 ⁶¹	3055 ¹⁷	629.4 ¹⁰⁹ 1175.0 ¹⁰⁹
Niobium	41	92.906	8.57 ⁴²	b. c. c.				241 ± 13 ³	260 ⁶⁴	2741 ± 27 ³ 2686 ⁶⁵	4813 ⁶⁴	1800.0 ¹⁰⁹
Nitrogen	7	14.0067	0.0012506 ²³	c. (α) h. (β)	35.62 ¹³ (α-β)			70 ⁴ (at ~35 K)		63.29 ¹	77.34 ^{13,23}	126.2 ¹⁵
Nobelium	102	(254)		c. p. h.		0.655 ⁵ 0.65 ³		500 ⁶⁷	400 ⁶⁸	3283 ± 10 ⁶⁹	5300 ± 100 ⁷⁰	
Osmium	76	190.2	22.48 ²³	c. p. h.								
Oxygen	8	15.9994	0.001429 ²³ (at 273.2 K and 1 atm)	b. c. orthorh. (α) r. (β) c. (γ)	23.876 ± 0.01 ¹¹² (α-β) 43.818 ± 0.01 ¹¹³ (β-γ)				250 ⁴ (at ~125 K) 500 ³⁶ (at ~250 K)	54.8 ⁵	90.19 ¹³ 90.18 ²³	154.8 ¹⁵
Palladium	46	106.4	12.02 ²³	f. c. c.				283 ± 16 ³	275 ¹⁴	1825 ^{3,10}	3200 ³	
Phosphorus	15	30.9738	1.82 ²³ (β) 2.22 ²³ (γ) 2.69 ²³ (δ)	h. (α) b. c. c. (β) c. (γ)	196 ¹⁷ (α-β) 298.16 ¹³ (β-γ) 298.16 ¹⁷ (β-δ)			193 ³ (white) 325 ³ (red)	576 ³ (white) 800 ³ (red)	317.3 ⁶ (white) 1300 ¹² (black)	553 ¹³	983.8 ¹⁵
Platinum	78	195.09	21.45 ²³	f. c. c.				234 ± 1 ³	225 ± 5 ³	2042 ^{3,10}	4100 ³	628.0 ¹⁵
Plutonium	94	(242)	19.737 ²³ (at 298.2 K)	Simple monoc. (α) b. c. monoc. (β) f. c. orthorh. (γ) f. c. c. (δ) b. c. t. (δ') b. c. c. (ε)	396.7 ¹² (α-β) 475 ¹³ (β-γ) 591.4 ¹³ (γ-δ) 729 ¹³ (δ-δ') 757 ± 3 ¹³ (δ'-ε)			171 ¹¹	176 ¹⁴	912.7 ⁵	3727 ¹⁵	
Polonium	84	(210)	9.3 ²³ (α) 9.5 ²³ (β)	Simple c. (α) r. (β) b. c. c.	327 ± 1.5 ¹⁶ (α-β)			81 ³		527.2 ⁵	1235 ²⁰	2261 ¹¹
Potassium	19	39.102	0.86 ²³	b. c. c.				89.4 ± 0.5 ³	100 ³	336.8 ⁵	1027 ³⁵	245.0 ¹⁰⁹ 214.0 ¹⁰⁹
Praseodymium	59	140.907	6.769 ²³	Double c. p. h. (α) b. c. c. (β)	1071 ³² (α-β)			85 ± 1 ⁶⁵	130 ¹⁸	1102 ± 2 ¹⁹	3616 ⁵⁰	890.0 ¹⁰⁹

Name	Atomic Number	Atomic Weight	Density, ^b kg m ⁻³ · 10 ⁻³	Crystal Structure	Phase Transition Temp., ^c K	Superconducting		N ₂ Col Temp., ^d K	Debye Temperature at 0 K, ^e K	Melting Point, ^f K	Boiling Point, ^g K	Critical Temp., ^h K
						Transition Temp., ^c K	Curie Temp., ^c K					
Promethium	61	(145)			1185 ¹²⁰ (α-β)				1553 ± 10 ^{#1}	2730 ³		
Protactinium	91	(231)	15.37 ⁴²	b. c. c. ²		1.4 ⁹		159 ³	1503 ⁵	4680 ³		
Radium	88	(226)	5 ²³					89 ³	973.2 ⁵	1900 ³		
Radon	86	(222)	0.00973 ²⁵ (at 273.2 K and 1 atm)	f. c. c. ⁷				400 ⁴ (at ~200 K)	202.2 ⁵	211 ¹³		377.16 ¹⁵
Rhenium	75	186.2	21.1 ⁴⁵	c. p. h. ²		1.698 ²⁶		429 ± 22 ³	3453 ⁵	6035 ± 135 ³	20000 ¹¹	
Rhodium	45	102.905	12.45 ⁴²	f. c. c. ⁷	possible transformation at 1373-1473 K ⁵¹			480 ± 12 ³	2233 ^{3,10,22}	3960 ± 60 ³		
Rubidium	37	85.47	1.53 ²³	b. c. c. ²				54 ± 4 ³	312.01 ⁵	959 ³³		18.115, 11F 2100 ¹⁰⁹ 2490 ¹⁰⁹
Ruthenium	44	101.07	12.2 ²⁹	c. p. h. (α) ? (β) ? (γ) ? (δ)	1308 ^{13,121} (α-β) 1473 ^{13,121} (β-γ) 1773 ^{13,121} (γ-δ)	0.45 ^{5,9}		600 ⁴⁷	2525 ± 10 ⁶³	-4325 ± 25 ³		
Samarium	62	150.35	7.54 ²³	r. (α) ³² b. c. c. ³² (β)	1190 ³² (α-β)			116 ⁴⁵	1345.2 ⁵³	2140 ³		5100 ¹⁰⁹
Scandium	21	44.956	3.00 ⁴²	c. p. h. (α) b. c. c. (β)	1607 ² (α-β)			470 ± 80 ⁵²	1812 ⁵	3537 ± 30 ³		
Selenium	34	78.96	4.50 ¹⁹ (α) 4.80 ¹⁹ (β)	monocl. (α) h. (β) amorphous ⁷	304 ^{84,117} (vitrification) 398 ¹³ (vit. -β) 423 ¹³ (α-β)	7.3 ⁸⁵ (at ~118 kbar)		151.7 ± 0.4 ⁸⁶ 80 ³⁶ (at ~415 K) 150 ¹⁵⁰ (at ~75 K)	490.2 ⁵	1009 ¹³ (Se ₂) 958.0 ¹³ (Se ₄ , 37) 1027 ¹³ (Se ₂)		1757 ¹³
Silicon	14	28.086	2.33 ⁴²	d. ⁷		7.5 ⁴⁷ (at 118-128 kbar)		647 ± 11 ³	1685 ± 2 ⁸⁷	2763 ²⁸		5159 ¹⁵
Silver	47	107.870	10.5 ²³	f. c. c. ²				228 ± 3 ³	1294.0 ^{3,13}	2468 ± 15 ⁴¹		7460 ¹¹
Sodium	11	22.9898	0.9712 ²³	b. c. c. ²	Martensitic transformation at low temp. ⁵⁶			157 ± 1 ³	371.0 ¹³	1154 ³⁵		2860 ¹¹ 2400 ¹⁰⁹
Strontium	38	87.62	2.60 ²³	f. c. c. (α) c. p. h. (β) b. c. c. (γ)	488 ²⁸ (α-β) 878 ⁸⁵ (β-γ)			147 ± 1 ²²	1042 ⁵	1645 ³		3059 ¹⁵ 3810 ¹⁰⁹
Sulfur	16	32.064	2.07 ²³ (α) 1.96 ²³ (β)	r. (α) ⁷ monocl. (β)	368.6 ¹³ (α-β)			200 ³ (β)	386.0 ⁴⁹ (α) 250 ⁸⁸ (α) 392.2 ⁵ (β) at 40 K) Subl. 368.6 ¹³ (at 0.0047 mm Hg)	717.75 ^{3,10} 1313 ¹⁵		
Tantalum	73	180.948	16.6 ⁴²	b. c. c. ²		4.483 ³ 4.48 ⁸		247 ± 13 ³	3269 ⁵	5760 ± 60 ³		22000 ¹¹

Name	Atomic Number	Atomic Weight	Density, ^b kg m ⁻³ · 10 ⁻³	Crystal Structure	Phase Transition Temp., K	Superconducting Transition Temp., K	Curie Temp., K	Neel Temp., K	Debye Temperature at 0 K, K	Debye Temperature at 298 K, K	Melting Point, K	Boiling Point, K	Critical Temp., K
Technetium	43	(99)	11.50 ²⁹	c. p. h. ²		8.22 ⁶ 11.2 ⁹			75.1 ³	422 ³	2473 ± 0 ³	5300 ³	
Tellurium	52	127.60	6.24 ²⁹ 6.00 (amorph.)	h. (α) ⁷ ? (β) ⁵ amorph.	621 ¹³ (α-β)	3.3 (Te II, at 56 kbar)			141 ± 12 ³		722.7 ⁵	1163 ± 1 ³	2329 ¹⁵
Terbium	65	158.924	8.25 ²⁹	c. p. h. ² b. c. c. ² (β)	Near m. p. (α-β)		219 ⁸⁰	230 ⁸⁰	150 ⁹¹	158 ⁴⁴	1629 ¹⁹	3810 ³	
Thallium	81	204.37	11.85 ²⁹	c. p. h. ² b. c. c. ² (β)	508.3 (α-β)	2.39 ⁵ 2.38 ⁸ 2.37 ⁹			88 ± 1 ³	96 ¹⁶	576.2 ¹⁹	1939 ³²	3219 ¹⁵
Thorium	90	232.038	11.7 ⁴²	f. c. c. ² (α) b. c. c. ² (β)	1673 ± 25 ³³ (α-β)	1.368 ⁵ 1.37 ⁹			170 ⁸⁴	100 ¹⁴	2023 ¹⁹	4500 ²⁰	14550 ¹⁰⁹
Thulium	69	168.934	9.32 ²⁹	c. p. h. ² (α) b. c. c. ² (β)	Near m. p. (α-β)		22 ⁸⁵ (ferro-antiferro.)	53 ⁸⁶	127 ± 1 ⁴⁵	167 ⁴⁴	1818 ⁵	2266 ⁹¹	6430 ¹⁰⁹
Tin	50	118.69	5.750 ²⁹ 7.31 (β)	f. c. c. ¹ (α) b. c. t. ¹ (β) r. ²³ (?)	286.2 ± 3 ⁸³ (α-β)	3.722 ⁵ (β)			236 ± 24 ³ (gray) 196 ± 9 ³ (white)	254 ³ (gray) 170 ¹⁴ (white)	505.06 ^{3,10} 2766 ± 14 ³	8000 ¹¹	8000 ¹¹
Titanium	22	47.90	4.5 ²⁹	c. p. h. ¹ (α) b. c. c. ² (β)	1155 ¹³ (α-β)	0.39 ^{5,9}			425 ± 5 ³	380 ¹⁴	1953 ⁹⁹	3586 ¹⁰⁰	
Tungsten	74	183.85	19.3 ²⁹	b. c. c. ²		0.011 ¹²²			388 ± 17 ³	312 ± 3 ³	3653 ^{3,10,15}	6000 ± 200 ³	23000 ¹¹
Uranium	92	238.03	19.07 ²⁸	orthorh. (α) t. ¹ (β) b. c. c. ² (γ)	37 ± 2 ¹¹⁹ (α-β) 93813 (α-β) 104913 (β-γ)	0.68 ⁵ (α) 1.80 ⁵ (γ)			200 ^{3M}	300 ³	1405.6 ± 0.6 ¹⁰¹	3950 ± 250 ¹⁰²	12500 ²⁷ 12000 ¹⁰⁹
Vanadium	23	50.942	6.1 ²⁸	b. c. c. ²		5.3 ⁵ 5.03 ⁹			326 ± 54 ³	390 ¹⁴	2192 ± 2 ⁶¹	3582 ± 42 ³	11200 ¹⁰⁹
Xenon	54	131.30	0.005851 ²⁸ (at 273.2 K and 1 atm)	f. c. c. ¹⁶							161.2 ²⁶	165.1 ¹³	289.75 ¹⁵
Ytterbium	70	173.04	7.02 ³²	f. c. c. ³² (α) b. c. c. ² (β)	1071 ^{2,5} (α-β)				118 ¹⁰³		1097 ¹²	1970 ³	4420 ¹⁰⁹
Yttrium	39	88.905	4.47 ²⁹	c. p. h. ² (α) b. c. c. ² (β)	1753 ¹¹⁹ (α-β)				268 ± 52 ³	214 ¹⁰⁴	1798 ¹¹³	3670 ¹⁰³	2950 ¹⁰⁹
Zinc	30	65.37	7.140 ²⁹	c. p. h. ²		0.875 ⁵ 0.85 ⁹			316 ± 20 ³	237 ± 3 ³	692.655 ^{3,110}	1175 ¹⁰⁴	2169 ¹⁰⁹ 2910 ¹⁰⁹
Zirconium	40	91.22	6.57 ⁵⁹	c. p. h. ¹ (α) b. c. c. ² (β)	1135 ¹³ (α-β)	0.546 ⁵ 0.55 ⁹			289 ± 24 ³	150 ¹⁴	2125 ¹⁹	4650 ²⁰	12300 ¹⁰⁹

REFERENCES

(Crystal Structures, Transition Temperatures, and Other Pertinent Physical Constants of the Elements)

1. Farr, J. D., Giorgi, A. L., and Bowman, M. G., USAEC Rept. LA-1545, 1-13, 1953.
2. Elliott, R. P., Constitution of Binary Alloys, 1st Suppl., McGraw-Hill, 1965.
3. Gschneider, K. A., Jr., Solid State Physics (Sietz, F. and Turnbull, D., Editors), 16, 275-426, 1964.
4. Gopal, E. S. R., Specific Heat at Low Temperatures, Plenum Press, 1966.
5. Weast, R. C. (Editor), Handbook of Chemistry and Physics, 47th Ed., The Chemical Rubber Co., 1966-67.
6. Foster, K. W. and Fauble, L. G., J. Phys. Chem., 64, 958-60, 1960.
7. The Institution of Metallurgists, Annual Yearbook, pp. 68-73, 1960-61.
8. Meaden, G. T., Electrical Resistance of Metals, Plenum Press, 1965.
9. Matthias, B. T., Geballe, T. H., and Compton, V. B., Rev. Mod. Phys., 35, 1-22, 1963.
10. Stimson, H. F., J. Res. NBS, 42, 209, 1949.
11. Grosse, A. V., Rev. Hautes Tempér. et Réfract., 3, 11-46, 1966.
12. Spedding, F. H. and Daane, A. H., J. Metals, 6 (5), 504-10, 1954.
13. Rossini, F. D., Wagman, D. D., Evans, W. H., Levine, S., and Jaffe, I., NBS Circ. 500, 537-822, 1952.
14. deLaunay, J., Solid State Physics, 2, 219-303, 1956.
15. Gates, D. S. and Thodos, G., AIChE J., 6 (1), 50-4, 1960.
16. Gray, D. E. (Coordinating Editor), American Institute of Physics Handbook, McGraw-Hill, 1957.
17. Sasaki, K. and Sekito, S., Trans. Electrochem. Soc., 59, 437-60, 1931.
18. Anderson, C. T., J. Am. Chem. Soc., 52, 2296-300, 1930.
19. Trombe, F., Bull. Soc. Chim. (France), 20, 1010-2, 1953.
20. Stull, D. R. and Sinke, G. C., Thermodynamic Properties of the Elements in Their Standard State, American Chemical Soc., 1956.
21. Rinck, E., Ann. Chim. (Paris), 18 (10), 455-531, 1932.
22. Roberts, L. M., Proc. Phys. Soc. (London), B70, 738-43, 1957.
23. Zemansky, M. W., Heat and Thermodynamics, 4th Ed., McGraw-Hill, 1957.
24. Martin, A. J. and Moore, A., J. Less-Common Metals, 1, 85, 1959.
25. Hill, R. W. and Smith, P. L., Phil. Mag., 44 (7), 636-44, 1953.
26. Moffatt, W. G., Pearsall, G. W., and Wulff, J., The Structure and Properties of Materials, Vol. I, pp. 205-7, 1964.
27. Grosse, A. V., Temple Univ. Research Institute Rept., 1-40, 1960.
28. Lyman, T. (Editor), Metals Handbook, Vol. 1, 8th Ed., American Soc. for Metals, 1961.
29. Lange, N. A. (Editor), Handbook of Chemistry, Revised 10th Edition, McGraw-Hill, 1967.
30. Paule, R. C., Dissertation Abstr., 22, 4200, 1962.
31. Burk, D. L. and Friedberg, S. A., Phys. Rev., 111 (5), 1275-82, 1958.
32. Spedding, F. H. and Daane, A. H. (Editors), The Rare Earths, John Wiley, 1961.
33. McHargue, C. J., Yakel, H. L., and Letter, C. K., ACTA Cryst., 10, 832-33, 1957.
34. Arajs, S. and Colvin, R. V., J. Less-Common Metals, 4, 159-68, 1962.
35. Bonilla, C. F., Sawhney, D. L., and Makansi, M. M., Trans. Am. Soc. Metals, 55, 877, 1962.
36. Rosenberg, H. M., Low Temperature Solid State Physics, Oxford at Clarendon Press, 1965.
37. Arajs, S., J. Less-Common Metals, 4, 46-51, 1962.
38. Edwards, A. R. and Johnstone, S. T. M., J. Inst. Metals, 84 (8), 313-7, 1956.
39. Lagneborg, R. and Kaplow, R., ACTA Metallurgica, 15 (1), 13-24, 1967.
40. Kittel, C., Introduction to Solid State Physics, 3rd Ed., John Wiley, 1967.
41. Kirshenbaum, A. D. and Cahill, J. A., J. Inorg. and Nucl. Chem., 25 (2), 232-34, 1963.
42. Touloukian, Y. S. (Ed.), Thermophysical Properties of High Temperature Solid Materials, MacMillan, Vol. 1, 1967.
43. Griffel, M., Skochdopole, R. E., and Spedding, F. H., J. Chem. Phys., 25 (1), 75-9, 1956.
44. Gschneider, K. A., Jr., Rare Earth Alloys, Van Nostrand, 1961.
45. Dreyfus, B., Goodman, B. B., Lacaze, A., and Trolliet, G., Compt. Rend., 253, 1764-6, 1961.

46. Spedding, F.H., Hanak, J.J., and Daane, A.H., *Trans. ADME*, 212, 379, 1958.
47. Buckel, W. and Wittig, J., *Phys. Lett. (Netherlands)*, 17 (3), 187-8, 1965.
48. Deardorff, D.K. and Kata, H., *Trans. ADME*, 215, 376-7, 1959.
49. Panish, M.B. and Reif, L., *J. Chem. Phys.*, 38 (1), 253-6, 1963.
50. Miller, A.E. and Daane, A.H., *Trans. ADME*, 230, 568-72, 1964.
51. Spedding, F.H. and Daane, A.H., *USAEC Rept. IS-350*, 22-4, 1961.
52. Montgomery, H. and Pells, G.P., *Proc. Phys. Soc. (London)*, 78, 622-5, 1961.
53. Kaufman, L. and Clougherty, E.V., *ManLabs, Inc., Semi-Annual Rept. No. 2*, 1963.
54. Lounasmaa, O.V., *Proc. 3rd Rare Earth Conf.*, 1963, Gordon and Breach, New York, 1964.
55. Baker, H., *WADC TR 57-194*, 1-24, 1957.
56. Reed, R.P. and Breedis, J.F., *ASTM STP 387*, pp. 60-132, 1966.
57. Hansen, M., *Constitution of Binary Alloys*, 2nd Edition, McGraw-Hill, p. 1268, 1958.
58. Smith, P.L., *Conf. Phys. Bases Temp., Inst. Intern. du Froid, Paris*, 281, 1956.
59. Powell, R.W. and Tye, R.P., *J. Less-Common Metals*, 3, 202-15, 1961.
60. Yamamoto, A.S., Lundin, C.E., and Nachman, J.F., *Denver Res. Inst. Rept.*, NP-11023, 1961.
61. Oriana, R.A. and Jones, T.S., *Rev. Sci. Instr.*, 25, 248-51, 1954.
62. Smith, J.F., Carlson, O.N., and Vest, R.W., *J. Electrochem. Soc.*, 103, 409-13, 1956.
63. Edwards, J.W. and Marshal, A.L., *J. Am. Chem. Soc.*, 62, 1382, 1940.
64. Morin, F.J. and Maita, J.P., *Phys. Rev.*, 129 (3), 1115-20, 1963.
65. Pendleton, W.N., *ASD-TDR-63-164*, 1963.
66. Woerner, P.F. and Wakefield, G.F., *Rev. Sci. Instr.*, 33 (12), 1456-7, 1962.
67. Walcott, N.M., *Conf. Phys. Bases Temp., Inst. Intern. du Froid, Paris*, 286, 1956.
68. White, G.K. and Woods, S.B., *Phil. Trans. Roy. Soc. (London)*, A251 (995), 273-302, 1959.
69. Douglass, R.W. and Adkns, E.F., *Trans. ADME*, 221, 248-9, 1961.
70. Panish, M.B. and Reif, L., *J. Chem. Phys.*, 37 (1), 128-31, 1962.
71. Bridgman, P.W., *J. Am. Chem. Soc.*, 36 (7), 1344-63, 1914.
72. Slack, G.A., *Phys. Rev.*, A139 (2), 507-15, 1965.
73. Sandenaw, T.A. and Gibney, R.B., *J. Phys. Chem. Solids*, 6 (1), 81-8, 1958.
74. Sandenaw, T.A., Olsen, C.E., and Gibney, R.B., *Plutonium 1960, Proc. 2nd Intern. Conf. (Grison, E., Lord, W.B.H., and Fowler, R.D., Editors)*, 66-79, 1961.
75. Mulford, R.N.R., *USAEC Rept. LA-2813*, 1-11, 1963.
76. Goode, J.M., *J. Chem. Phys.*, 26 (5), 1269-71, 1957.
77. Cable, J.W., Moon, R.M., Koehler, W.C., and Wollan, E.O., *Phys. Rev. Letters*, 12 (20), 553-5, 1964.
78. Murao, T., *Progr. Theoret. Phys. (Kyoto)*, 20 (3), 277-86, 1958.
79. Grigor'ev, A.T., Sokolovskaya, E.M., Budennaya, L.D., Iyutina, I.A., and Maksimona, M.V., *Zhur. Neorg. Khim.*, 1, 1052-63, 1956.
80. Daane, A.H., *USAEC AECD-3209*, 1950.
81. Weigel, F., *Angew. Chem.*, 75, 451, 1963.
82. Nassau, K. and Broyer, A.M., *J. Am. Ceram. Soc.*, 45 (10), 474-8, 1962.
83. McKeown, J.J., *State Univ. of Iowa, Ph. D. Dissertation*, 1-113, 1958.
84. Abdullaev, G.B., M'akhtiyeva, S.I., Abdinov, D.Sh., and Aliev, G.M., *Phys. Letters*, 23 (3), 215-6, 1966.
85. Wittig, J., *Phys. Rev. Letters*, 15 (4), 159, 1965.
86. Fukuroi, T. and Muto, Y., *Tohoku Univ. Res. Inst. Sci. Rept.*, A8, 213-22, 1956.
87. Olette, M., *Compt. Rend.*, 244, 1033-6, 1957.
88. Sheldon, E.A., and King, A.J., *ACTA Cryst.*, 6, 100, 1953.
89. Eastman, E.D. and McGavock, W.C., *J. Am. Chem. Soc.*, 59, 145-51, 1937.
90. Araj, S. and Colvin, R.V., *Phys. Rev.*, A136 (2), 439-41, 1964.
91. Roach, P.R. and Lounasmaa, O.V., *Bull. Am. Phys. Soc.*, 7, 408, 1962.
92. Shchukarev, S.A., Semenov, G.A., and Rat'kovskii, I.A., *Zh. Neorgan. Khim.*, 7, 469, 1962.
93. Pearson, W.B., *A Handbook of Lattice Spacings and Structures of Metals and Alloys*, Pergamon Press, 1953.

94. Smith, P.L. and Walcott, N.M., Conf. Phys. Basses Temp., Inst. Intern. du Froid, 263, 1956.
95. Davis, D.D. and Bozorth, R.M., Phys. Rev., 118 (6), 1543-5, 1950.
96. Aliev, N.G. and Volkenstein, N.V., Soviet Physics - JETP, 22 (5), 997-8, 1966.
97. Spedding, F.H., Barton, R.J., and Daane, A.H., J. Am. Chem. Soc., 79, 5160, 1957.
98. Raynor, G.V. and Smith, R.W., Proc. Roy. Soc. (London), A244, 101-9, 1958.
99. Savitskii, E.M. and Burhkanov, G.S., Zhur. Neorg. Khim., 2, 2609-16, 1957.
100. Argent, B.B. and Milne, J.G.C., Niobium, Tantalum, Molybdenum and Tungsten, Elsevier Publ. Co. (Quarrell, A.G., Editor), pp. 160-8, 1951.
101. Argonne National Laboratory, USAEC Rept. ANL-5717, 1-67, 1957.
102. Holden, A.N., Physical Metallurgy of Uranium, Addison-Wesley, 1958.
103. Lounasmaa, O.V., Phys. Rev., 129, 2460-4, 1963.
104. Jennings, L.D., Miller, R.E., and Spedding, F.H., J. Chem. Phys., 33 (6), 1849-52, 1960.
105. Ackerman, R.J. and Rauh, E.G., J. Chem. Phys., 36 (2), 448-52, 1962.
106. Rosenblatt, G.M. and Birchenall, C.E., J. Chem. Phys., 35 (3), 788-94, 1961.
107. Streb, W.E., Jordan, T.H., and Lipscomb, W.N., J. Chem. Phys., 37 (12), 2962-5, 1962.
108. Samsonov, G.V. (Editor), Handbook of the Physicochemical Properties of the Elements, Plenum Press, 1968.
109. Kopp, I.Z., Russ. J. Phys. Chem., 41 (6), 782-3, 1967.
110. Stimson, H.F., in Temperature, Its Measurement and Control in Science and Industry (Herzfeld, C.M., Ed.), Vol. 3, Part 1, Reinhold, New York, pp. 59-66, 1962.
111. McLaren, E.H., in Temperature, Its Measurement and Control in Science and Industry (Herzfeld, C.M., Ed.), Vol. 3, Part 1, Reinhold, New York, pp. 185-93, 1962.
112. Orlova, M.P., in Temperature, Its Measurement and Control in Science and Industry (Herzfeld, C.M., Ed.), Vol. 3, Part 1, Reinhold, New York, pp. 179-83, 1962.
113. Grosse, A.V., J. Inorg. Nucl. Chem., 28, 2125-9, 1966.
114. Hochman, J.M. and Bonilla, C.F., in Advances in Thermophysical Properties at Extreme Temperatures and Pressures (Gratch, S., Ed.), ASME 3rd Symposium on Thermophysical Properties, Purdue University, March 22-25, 1965, ASME, pp. 122-30, 1965.
115. Dillon, I.G., Illinois Institute of Technology, Ph.D. Thesis, June 1965.
116. Hochman, J.M., Silver, I.L., and Bonilla, C.F., USAEC Rept. CU-2660-13, 1964.
117. Abdullaev, G.B., Mekhtieva, S.I., Abdinov, D.Sh., Aliev, G.M., and Aieva, S.G., Phys. Status Solidi, 13(2), 315-23, 1966.
118. Fisher, E.S. and Dever, D., Phys. Rev., 2, 170(3), 607-13, 1968.
119. Beaudry, B.J., J. Less-Common Metals, 14(3), 370-2, 1968.
120. Williams, R.K. and McElroy, D.L., USAEC Rept. ORNL-TM 1424, 1-32, 1966.
121. Jaeger, F.M. and Rosenbaum, E., Proc. Nederland Akademie van Wetenschappen, 44, 144-52, 1941.
122. Gibson, J.W. and Hein, R.A., Phys. Letters, 12(25), 688-90, 1964.
123. Grosse, A.V., Research Institute of Temple Univ., Report on USAEC Contract No. AT(30-1)-2082, 1-71, 1965.

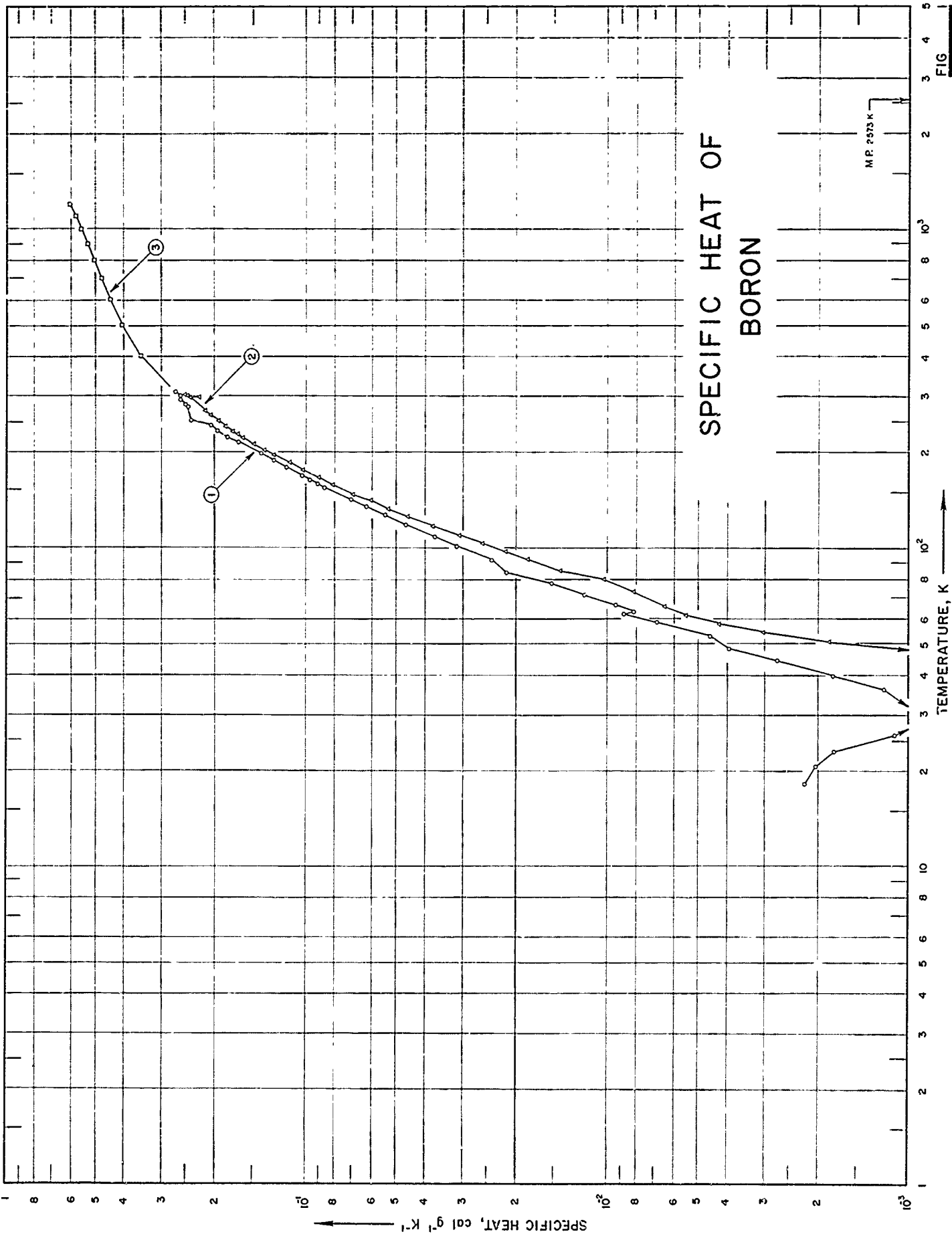

SPECIFICATION TABLE NO. 1 SPECIFIC HEAT OF BORON

(Impurity < 2.00% each; total impurities < 5.00%)

[For Data Reported in Figure and Table No. 1]

Curve No.	Ref. No.	Year	Temp. Range, K	Reported Error, %	Name and Specimen Designation	Composition (weight percent), Specifications and Remarks
1	92	1951	18-308			Extremely pure; amorphous.
2	92	1951	17-304			Extremely pure; crystalline; heated under vacuum to 1700-1900 C.
3	162	1960	298-1200		Boron III	0.08 Si, 0.06 Na, 0.04 Fe and 0.02 Ni; amorphous; sample supplied by the Fairmount Chemical Company; sealed in gold ampoules.

DATA TABLE NO. 1 SPECIFIC HEAT OF BORON
 [Temperature, T, K; Specific Heat, Cp, Cal g⁻¹ K⁻¹]

T	Cp	T	Cp	T	Cp
18.25	2.201 x 10 ⁻³	303.26	2.629 x 10 ⁻¹ *	251.28	1.954 x 10 ⁻¹
20.55	2.044	308.29	2.725	261.67	2.078
23.04	1.757	<u>CURVE 2</u>		270.29	2.172
25.89	1.110	16.90	4.312 x 10 ⁻⁴ *	297.74	2.263
29.08	8.602 x 10 ⁻⁴ *	19.47	4.625*	296.44	2.434
35.98	1.202 x 10 ⁻³	21.89	6.937*	301.79	2.487
39.70	1.776	24.90	8.232*	303.71	2.516
44.43	2.710	27.84	5.920*	<u>CURVE 3</u>	
48.52	3.940	30.48	5.550*	298	2.643 x 10 ⁻¹ *
52.97	4.551	32.74	4.782*	400	3.562
58.71	6.873	35.47	3.811*	500	4.099
62.25	8.806	40.48	3.691*	600	4.490
63.10	8.121	43.87	5.938*	700	4.814
66.10	9.379	48.12	1.508 x 10 ⁻³	800	5.102
71.20	1.193 x 10 ⁻²	50.96	1.831	900	5.369
77.03	1.539	54.51	3.006	1000	5.623
83.79	2.154	57.77	4.246	1100	5.868
91.78	3.405	61.46	5.485	1200	6.108
100.83	3.154	65.23	6.484		
108.93	3.737	72.71	8.158		
118.06	4.625	79.58	1.023 x 10 ⁻²		
127.04	5.457	84.7	1.434		
135.43	6.299	91.61	1.828		
142.40	7.067	97.02	2.167		
155.10	8.676	103.11	2.585		
159.49	9.120	109.72	3.080		
163.88	9.694	116.81	3.765		
168.71	1.027 x 10 ⁻¹	125.43	4.588		
178.62	1.156	133.00	5.309		
187.96	1.281	140.54	6.086		
197.89	1.405	147.98	6.928		
215.29	1.680	157.86	8.103		
223.73	1.833	166.08	9.000		
233.59	1.973	175.54	1.020 x 10 ⁻¹		
243.69	2.083	185.96	1.141		
252.69	2.415	195.77	1.280		
277.62	2.477*	202.71	1.375		
279.62	2.471*	211.43	1.490		
283.18	2.476*	220.70	1.617		
283.85	2.530*	227.43	1.690		
288.97	2.547*	232.75	1.752		
291.10	2.622*	241.07	1.850		
296.58	2.610*				
300.26	2.629				

* Not shown on plot

SPECIFIC HEAT OF CARBON (DIAMOND)

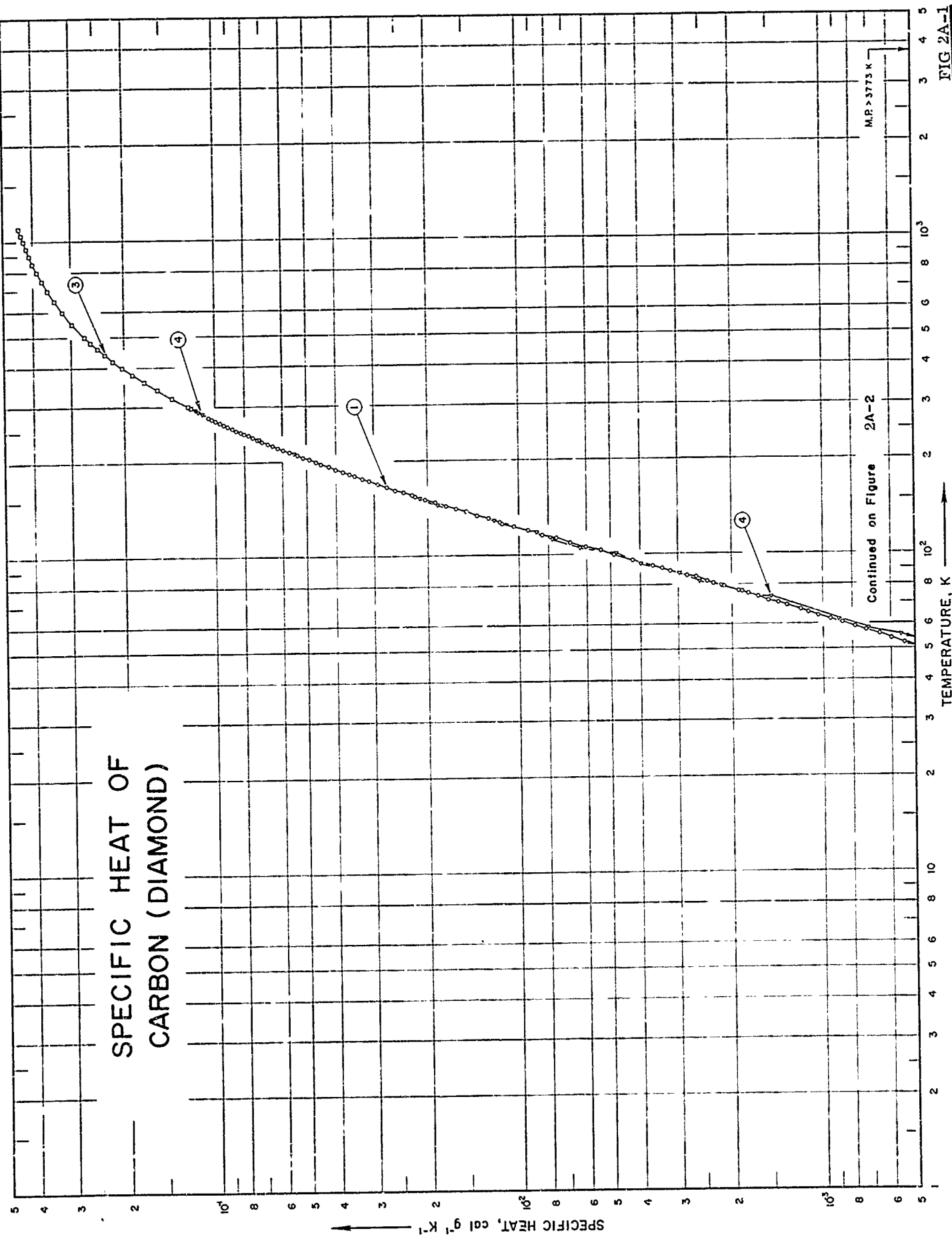

Continued on Figure 2A-2
M.P. > 3773 K
FIG 2A-1

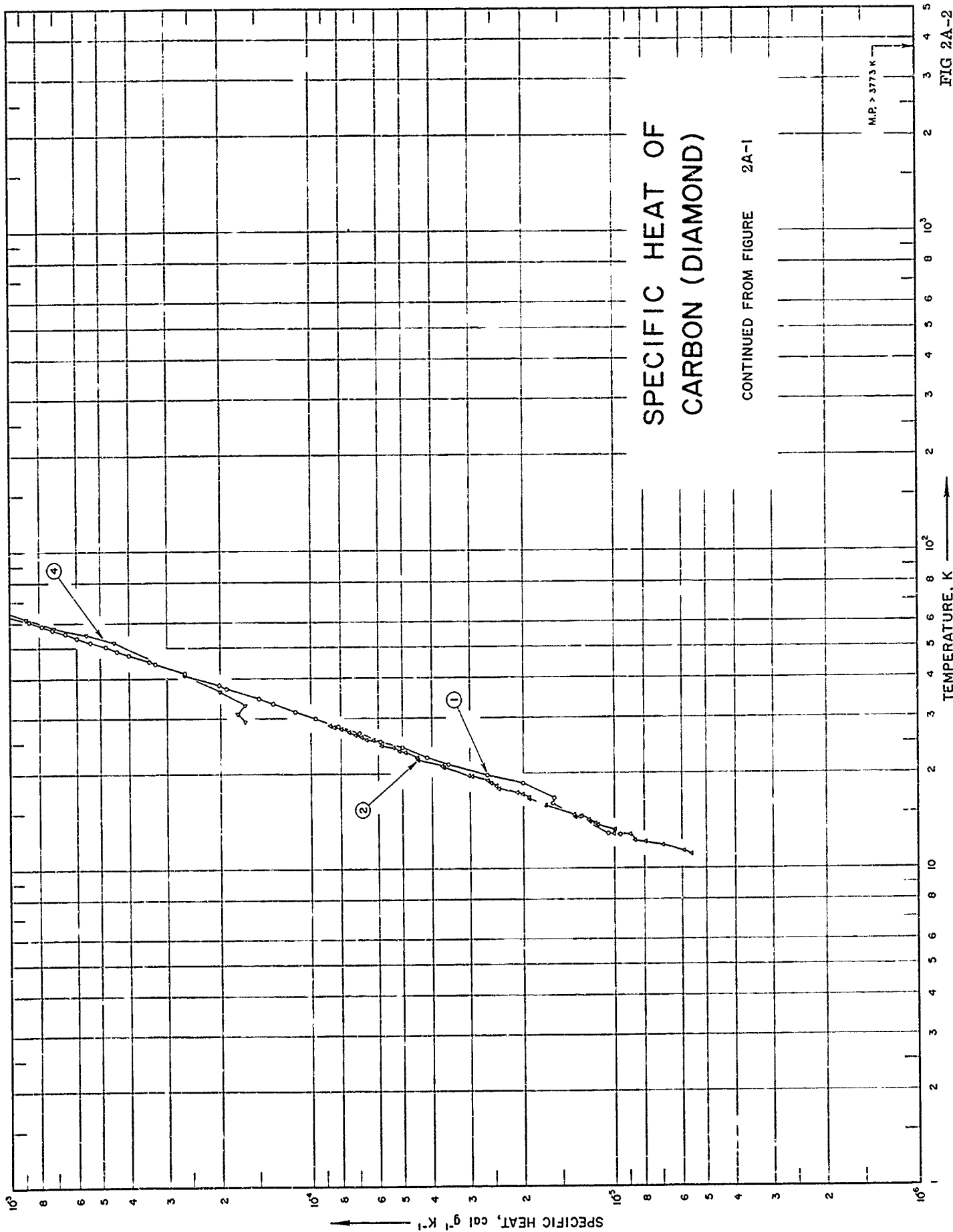

SPECIFIC HEAT OF
CARBON (DIAMOND)

CONTINUED FROM FIGURE 2A-1

SPECIFICATION TABLE NO. 2-A SPECIFIC HEAT OF CARBON (DIAMOND)

(Impurity < 2.00% each; total impurities < 5.00%)

[For Data Reported in Figure and Table No. 2-A]

Curve No.	Ref. No.	Year	Temp. Range, K	Reported Error, %	Name and Specimen Designation	Composition (weight percent)	Specifications and Remarks
1	1	1958	12- 272	< 6.0	Commercial diamond	Commercial grade; under helium atmosphere.	
2	2	1958	11- 200	< 6.0	Diamond chips	High purity.	
3	3	1962	298-1100	0.4	Diamond		
4	4	1953	30- 300		Fragmanted bort	Traces of Al, Mg; low concentrations Fe, Si, region of misalignment; 20% crystals were fluorescent.	

DATA TABLE NO. 2-A SPECIFIC HEAT OF CARBON (DIAMOND)

[Temperature, T, K; Specific Heat, C_p , Cal $g^{-1} K^{-1}$]

T	CURVE 1		CURVE 1 (cont.)		CURVE 2 (cont.)		CURVE 2 (cont.)		CURVE 3		CURVE 4	
	T	C_p	T	C_p	T	C_p	T	C_p	T	C_p	T	C_p
12.833	9.58 x 10 ⁻⁶	76.409	182.415	3.623 x 10 ⁻²	13.774	1.13 x 10 ⁻⁵	81.236	2.291 x 10 ⁻³ *	298.15	1.218 x 10 ⁻¹	29.47	1.7 x 10 ⁻⁴
12.968	1.05 x 10 ⁻⁵	76.685	185.742	3.808	13.844	1.16	82.239	2.406*	300	1.233	31.00	1.8
16.015	1.60	79.165	189.157	4.010	14.202	1.22	80.239	2.406*	320	1.399	33.08	1.7
16.745	1.58	79.452	192.641	4.227	14.232	1.22	80.160	2.025*	340	1.565	36.53	2.0*
18.631	2.01	80.868	196.192	4.449	14.540	1.31	81.907	2.359*	360	1.727	41.63	2.7*
19.757	2.72	81.972	199.611	4.660	14.587	1.35	83.533	2.546*	380	1.886	44.07	3.2*
21.304	3.53	82.410	203.157	4.901	14.676	1.29	85.490	4.357 x 10 ⁻² *	400	2.038	52.18	4.5
22.464	4.18	84.808	206.809	5.139	14.756	1.37	197.400	4.540	420	2.184	55.20	5.7
24.100	5.00	85.550	210.341	5.387	14.756	1.72	199.000	4.636*	440	2.323	58.31	7.2
25.276	5.90	87.112	215.014	5.701	15.800	1.69			460	2.456	62.54	8.89
26.994	6.92	88.700	218.511	5.955	16.549	1.90			480	2.582	66.40	1.06 x 10 ⁻³ *
28.299	8.12	90.190	222.107	6.207	17.271	2.01			500	2.702	69.36	1.30 x 10 ⁻³ *
29.992	9.75	92.201	225.595	6.467	17.400	2.09			550	2.973	73.20	1.48
31.332	1.12 x 10 ⁻⁴	96.025	229.264	6.723	17.811	2.40			600	3.210	74.91	1.70
33.407	1.34	99.904	232.816	7.003	17.811	2.40			650	3.415	76.16	1.85*
34.606	1.48	103.985	236.364	7.259	18.236	2.45			700	3.593	79.57	2.17
37.316	1.90	106.381	239.816	7.527	18.655	2.55			750	3.747	82.36	2.56
38.046	2.02	109.756	243.176	7.784	18.996	2.61			800	3.883	87.34	2.97
41.319	2.61	113.212	246.452	8.037	19.546	2.95			850	4.002	93.70	3.98
41.325	2.61	116.719	249.159	8.239	19.686	3.07			900	4.110	100.33	4.80
44.491	3.28	120.283	252.541	8.517	21.023	3.67			950	4.205	106.71	6.32
45.228	3.44	123.697	256.939	8.794	21.183	3.69			1000	4.302	112.68	7.77
47.570	4.01	126.975	261.648	9.105	22.209	4.47			1050	4.392	118.02	8.75
48.985	4.41	127.870	265.168	9.360	22.429	4.48			1100	4.483	123.42	1.03 x 10 ⁻² *
50.450	4.82	131.154	268.789	9.678	23.319	4.89					129.11	1.21*
52.045	5.40	134.485	270.507	9.972	23.577	5.12					134.78	1.40*
53.980	5.98	137.805	274.134	1.028 x 10 ⁻¹	24.238	5.37					141.38	1.69*
55.597	6.54	141.116	277.675	1.057	24.648	5.87					146.55	1.86
57.333	7.21	144.495			24.934	5.82					152.64	2.12*
58.957	7.87	147.945			25.517	6.27					158.46	2.40*
60.540	8.62	151.444			25.619	6.58					164.10	2.70*
62.189	9.42	154.989			26.188	6.82					169.53	2.91*
63.648	1.031 x 10 ⁻³	156.186			26.559	7.15					175.06	3.14*
65.392	1.124	159.510			27.066	7.50					179.78	3.49*
66.750	1.194	162.867			27.626	7.98					185.29	3.78*
68.591	1.311	166.298			28.070	8.38					191.11	4.14*
70.070	1.401	169.777			28.418	8.63					196.00	4.43*
71.787	1.512	173.316			28.880	8.83 x 10 ⁻⁶					200.29	4.68*
73.386	1.637	176.730			29.061	9.92*					205.77	5.05*
74.995	1.763	180.042			30.178	2.190*					210.85	5.36

* Not shown on plot

DATA TABLE NO. 2-A (continued)

T	C _p
	CURVE 4 (cont.)
213.09	5.50 x 10 ⁻²
216.67	5.78*
226.77	6.54*
231.79	6.77*
236.78	7.20
241.93	7.62*
246.39	7.88*
250.76	8.24*
257.11	8.73*
265.99	9.52
271.55	1.000 x 10 ⁻¹ *
277.48	1.043*
281.26	1.079
285.22	1.118
290.80	1.149
293.51	1.172*
299.07	1.224*
300.57	1.234

* Not shown on plot

UNCLASSIFIED

SECURITY CLASSIFICATION OF THIS PAGE (When Data Entered)

REPORT DOCUMENTATION PAGE		READ INSTRUCTIONS BEFORE COMPLETING FORM
1. REPORT NUMBER	2. GOVT ACCESSION NO.	3. RECIPIENT'S CATALOG NUMBER
4. TITLE (and Subtitle) Thermophysical Properties of Matter--The TPRC Data Series--Vol. 5. Specific Heat Nonmetallic Solids		5. TYPE OF REPORT & PERIOD COVERED Data Book (See block 18)
7. AUTHOR(s) Touloukian, Y.S. and Buyco, E. H.		6. PERFORMING ORG. REPORT NUMBER TPRC Data Series/Vol. 5
9. PERFORMING ORGANIZATION NAME AND ADDRESS CINDAS/Purdue University 2595 Yeager Road West Lafayette, IN 47906		8. CONTRACT OR GRANT NUMBER(s) F33615-68-C-1229
11. CONTROLLING OFFICE NAME AND ADDRESS Defense Logistics Agency DTIC-AI/Cameron Station Alexandria, VA 22314		10. PROGRAM ELEMENT, PROJECT, TASK AREA & WORK UNIT NUMBERS
14. MONITORING AGENCY NAME & ADDRESS (if different from Controlling Office) Army Materials & Mechanics Research Center Attn: DRXMR-P/Arsenal Street Watertown, MA 02172		12. REPORT DATE 1970
		13. NUMBER OF PAGES 1,737
16. DISTRIBUTION STATEMENT (of this Report) Unlimited		15. SECURITY CLASS. (of this report) Unclassified
		15a. DECLASSIFICATION/DOWNGRADING SCHEDULE
17. DISTRIBUTION STATEMENT (of the abstract entered in Block 20, if different from Report)		
18. SUPPLEMENTARY NOTES TEPIAC Publication (DTIC Source Code 413571) Limited hard copies on Data Book available from publisher: Plenum Publishing Corp, 227 W. 17th St., New York, NY 10011 Price \$150/copy. Microfiche copy available from DTIC		
19. KEY WORDS (Continue on reverse side if necessary and identify by block number) *Specific heat--*thermophysical properties--*elements--*nonmetallic solids--alumina--antimonides--carbides--nitrides--oxides--aluminum oxide--phosphides-- (continue on reverse side)		
20. ABSTRACT (Continue on reverse side if necessary and identify by block number) The TPRC Data Series published in 13 volumes plus a Master Index volume constitutes a permanent and valuable contribution to science and technology. This 17,000 page Data Series should form a necessary acquisition to all scientific and technological libraries and laboratories. These volumes contain an enormous amount of data and information for thermophysical properties on more than 5,000 different materials of interest to reserachers in government laboratories and the defense industrial establishment. (continue on reverse side)		

DD FORM 1473 1 JAN 73 EDITION OF 1 NOV 65 IS OBSOLETE

Unclassified
SECURITY CLASSIFICATION OF THIS PAGE (When Data Entered)

19. KEYWORDS (cont)

silicates--sulfates--inorganic compounds--sulfides--iodides--chlorides--
carbonates--nitrates--beryllia--fluorides--beryllium oxides--brimstone--
bromides--selenides--tellurides--calcia--borates--carbon--graphite--diamond--
cermets --corundum--iron oxides--glass--borosilicate glass--silica glass--
leaded glass--lime glass--pyrex glass--soda glass--pyroceram--quartz--
quartz glass--silica

20. ABSTRACT (cont)

Volume 5. 'Specific Heat - Nonmetallic Solids, ' Touloukian, Y.S. and
Buyco, E. H., 1737 pp., 1970.

Volume 5 in this 14 volume TPRC Data Series provides data on nonmetallic
materials which are in the solid state at normal temperature and pressure,
including five elements, 83 simple oxides, 115 complex oxides, 298 nonoxide
compounds, and 20 groups of glasses and cermets.

1737 pages, 1970 \$150.00 (\$180.00 outside US)

0101

FIGURE SHOWS ONLY 20 OF THE CURVES REPORTED IN TABLE

SPECIFIC HEAT OF CARBON (GRAPHITE)

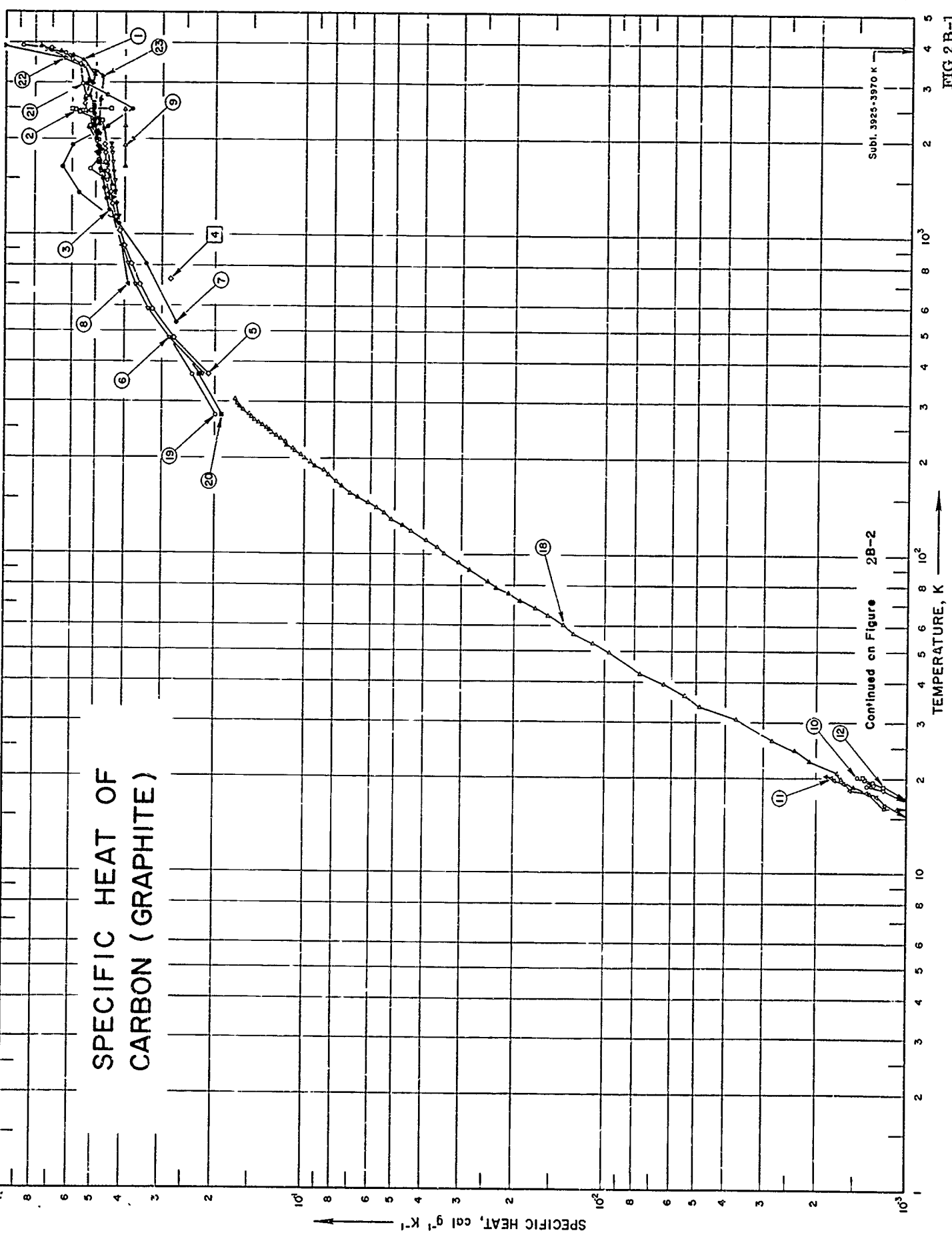

SPECIFIC HEAT OF CARBON (GRAPHITE)

CONTINUED FROM FIGURE 2B-1

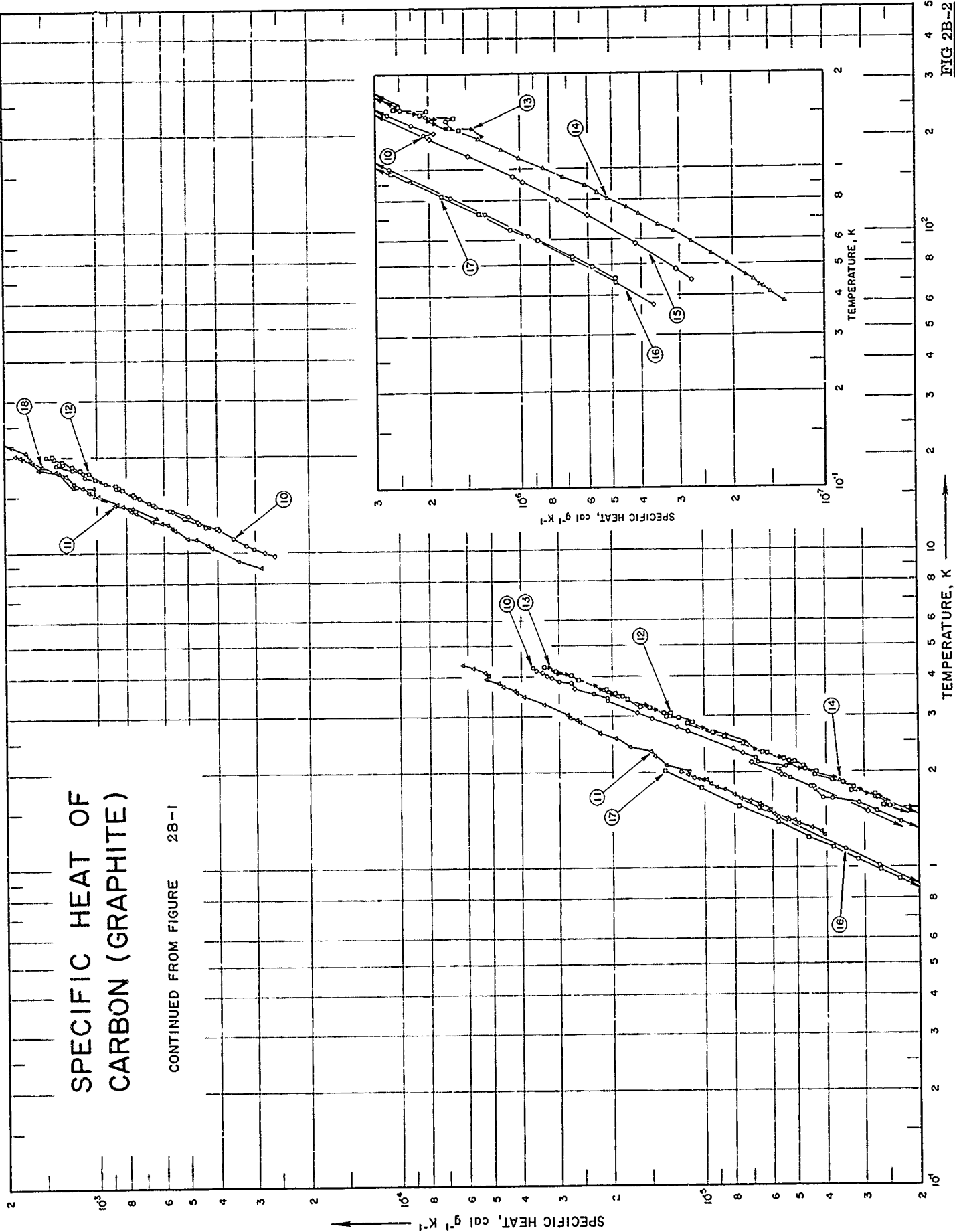

FIG 2B-2

SPECIFICATION TABLE NO. 2-B SPECIFIC HEAT OF CARBON (GRAPHITE)

(Impurity < 2.00% each; total impurities < 5.00%)

[For Data Reported in Figure and Table No. 2-B]

Curve No.	Ref. No.	Year	Temp. Range, K	Reported Error, %	Name and Specimen Designation	Composition (weight percent), Specifications and Remarks
1	5	1960	1447-1676	± 5.0	3474 D	Very fine-grained and uniform; extruded; density = 65.0 lb ft ⁻³ .
2	6	1962	1993-2483	± 5.0	Carbon graphite	< 0.001 Al, < 0.001 Si, 0.0001 B, Ca, and Mg.
3	7	1965	1200-2600	0.14		Density = 131 lb ft ⁻³ .
4	8	1962	729		Graphite brick	
5	9	1960	366-1922	± 1.0	7087	Grade 7087 graphite; extruded; sealed in 95% argon - 5% hydrogen; density = 106.5 lb ft ⁻³ (75 F).
6	9	1960	366-1922	± 1.0	GBH	Grade GBH graphite; molded; sealed in 95% argon - 5% hydrogen; density = 109.0 lb ft ⁻³ (75 F).
7	10	1962	533-3033	± 5.0	ATJ	99.5 C, 0.2 Si, 0.1 Fe, trace Ca, Mg, molded and fired; density = 110.3 lb ft ⁻³ . Sealed in helium.
8	11	1960	699-1811	< 2.9	ATJ	
9	10	1962	1644-2477	± 5.0	CS	
10	13	1958	1-20	± 0.8	H-CS-II pile graphite	0.4 ash, 0.005 gas, trace Fe, Mg, Ni.
11	13	1958	1-20	± 0.8	SA-25	< 0.05 ash, 0.01 gas, slight trace B, Fe, Si.
12	13	1958	1-20	± 0.8	CNG	< 0.05 ash, 0.001 gas, trace Mg, Ni, slight trace B; Canadian Natural Graphite.
13	13	1958	1-20	± 0.8	CNG-B	0.0004 B, Boronated Canadian Natural Graphite.
14	14	1963	0.4-2	± 2.0	NMG	Natural Madagascar Graphite; pumped for at least 3 days at room temperature; > 100 μ average crystallite dimension; very low degree of stacking faults.
15	14	1963	0.4-2	± 2.0	Pile graphite	Pumped for at least 3 days at room temperature; 240 Å average crystallite dimensions; low degree of stacking faults.
16	14	1963	0.4-2	± 2.0	Graphitized lamp-black SA 25	Pumped for at least 3 days at room temperature; average crystallite dimensions L _c = 125 Å, L _a = 90 Å; high degree of stacking faults.
17	14	1963	0.4-2	± 2.0	Pyrographite	Pumped for at least 3 days at room temperature; average crystallite dimensions L _c = 265 Å, L _a = 200 Å; very high degree of stacking faults.
18	15	1953	13-300		CS	High purity.
19	16	1956	273-1922		GBH	Under He atmosphere.
20	16	1956	273-1922		7087	Under He atmosphere.
21	17	1957	13-300		Acheson	0.27 Al, 0.07 Fe, 0.07 Si, 0.06 Pb, trace, Ca, Mg, Cu, Cr, V, Be, Ti and B; 1.5 x 10 ²¹ cm ⁻¹ total integrated neutron flux; exposed in Hanford reactor for several years at 350 C; kept in a vacuum for 24 hours.
22	12	1955	17-300	± 5.0	Ceylon natural graphite	0.06 ash, large foliated crystals.

DATA TABLE NO. 2-B SPECIFIC HEAT OF CARBON (GRAPHITE)

[Temperature, T, K; Specific Heat, C_p , Cal $g^{-1} K^{-1}$]

T	C_p	T	C_p	T	C_p	T	C_p	T	C_p
1447	4.41 x 10 ⁻¹	1900	4.94 x 10 ⁻¹	1478	4.33 x 10 ⁻¹	1799	4.504 x 10 ⁻⁶	14.163	6.380 x 10 ⁻⁴
1676	4.57	2000	4.96	1589	4.36	1915	5.292	14.429	6.697
1694	4.90	2100	5.00	1700	4.39	2037	5.783	14.774	7.067*
1839	4.90	2200	5.03	1811	4.41	2074	5.427	14.951	7.174
1868	4.81	2300	5.05	1866	4.42	2149	6.727	15.355	7.539
2103	4.91	2400	5.08			2200	6.850*	16.130	8.533
2232	4.91	2500	5.09			2202	6.833	16.186	8.392
2278	4.54*	2600	5.11			2285	7.504	16.871	9.250
2555	5.09			533	2.7 x 10 ⁻¹	2344	8.040*	17.443	1.083 x 10 ⁻³
2722	5.25			811	3.4	2369	8.016	17.924	1.117
2778	5.23*			1089	4.2	2688	1.137 x 10 ⁻⁵	18.347	1.199
3000	5.14			1366	5.7	2760	1.231	18.922	1.365
3077	4.30*	729	2.79*	1644	6.5	2937	1.478	19.922	1.282
3198	5.07*	729	2.80*	1922	6.0	3066	1.658	20.114	1.469
3221	5.05*			2200	1.6	3341	2.083		
3525	5.52			2478	3.8	3420	2.097		
3656	5.97			2755	4.6	3519	2.317		
3711	6.00*	366	2.11 x 10 ⁻¹	3033	5.4	3596	2.428		
3719	5.59*	478	2.75			3596	2.479*	1.267	4.076 x 10 ⁻⁶
3739	5.84*	589	3.24			3660	2.652	1.296	4.197
3767	6.58	700	3.56			3802	2.748	1.336	4.493
3818	7.02	811	3.80			3863	2.993	1.371	4.945
3905	7.65	922	4.00			3901	3.022*	1.405	5.152
		1033	4.17			3960	3.170	1.415	5.334
		1144	4.29			4000	3.289	1.427	5.397
		1255	4.40			4050	3.357	1.518	5.968
		1366	4.48			4097	3.395*	1.473	6.237
		1478	4.55*			4127	3.401	1.520	6.131
		1529	4.60			4177	3.401	1.544	6.563*
		1700	4.64			4177	3.561	1.562	6.550
		1811	4.68			4189	3.479*	1.573	6.629
		1866	4.69			4217	3.518*	1.620	7.112
						4279	3.736*	1.641	7.602
						4285	3.757	1.696	8.027
						9719	2.581 x 10 ⁻⁴	1.717	8.135*
						9959	2.765	1.765	8.608
						10233	3.004	1.788	9.100
						10577	3.189	1.882	9.489
						10902	3.608*	1.826	9.325*
						11211	3.529	1.836	9.542*
						11477	3.933*	1.856	9.542*
						11766	3.927	1.883	9.892
						12085	4.325	1.890	1.017 x 10 ⁻⁵
						12595	4.622	1.957	1.132
						13147	4.965	1.976	1.095*
						13662	5.548	2.010	1.123
								2.025	1.152*

* Not shown on plot

DATA TABLE NO. 2-B (continued)

CURVE 11 (cont'd)		CURVE 12 (cont'd)		CURVE 12 (cont'd)		CURVE 13 (cont'd)		CURVE 15		CURVE 18	
T	Cp	T	Cp	T	Cp	T	Cp	T	Cp	T	Cp
14.378	8.483 x 10 ⁻⁴	1.950	4.363 x 10 ⁻⁶	13.125	5.217 x 10 ⁻⁶	2.488	7.402 x 10 ⁻⁶	0.4477	2.74 x 10 ⁻⁷	12.92	6.3 x 10 ⁻⁴
15.119	9.842	1.964	4.357*	13.664	5.648*	2.601	8.458	0.4829	3.10	13.77	7.6
15.524	1.094 x 10 ⁻³	1.982	4.311	14.119	6.283*	2.666	9.208	0.5221	4.19	15.15	1.01 x 10 ⁻³
16.034	1.117	2.008	4.412*	14.427	6.467	2.745	1.011 x 10 ⁻⁵	0.7175	6.02	16.06	1.02
16.589	1.187	2.016	4.398*	14.885	7.121	2.945	1.213*	0.8025	7.52	16.20	1.18
17.557	1.267	2.036	4.707	15.180	7.476	3.059	1.362*	0.9120	9.83	17.88	1.32
18.101	1.357	2.056	4.942	15.393	7.408*	3.131	1.430	0.9469	1.067 x 10 ⁻⁶	18.73	1.51
18.476	1.547	2.061	4.892*	15.894	8.157	3.238	1.549	1.1066	1.484	19.93	1.65
19.352	1.622	2.070	4.773*	16.209	8.633*	3.327	1.658*	1.2089	1.998	20.77	1.70
19.825	1.741	2.111	5.078*	16.311	8.567	3.439	1.843*	1.4306	2.11	22.47	2.11
20.034	1.737	2.142	5.073*	17.113	9.825*	3.530	2.005	1.7229	4.425	24.67	2.36
20.138	1.774	2.151	5.303	17.177	1.007*	3.643	2.188	1.9532	5.623	26.29	2.82
20.337	1.851	2.198	5.517	17.237	1.027*	3.735	2.281	2.1395	7.047	33.57	3.69
		2.254	6.105*	17.846	1.053	3.844	2.473*			36.33	4.86
		2.296	6.259	18.223	1.126	3.964	2.571*			39.36	5.46
		2.299	6.500	18.741	1.197	4.051	2.813			42.48	6.39
		2.454	7.510	19.124	1.226	4.178	3.085			49.44	7.67
		2.567	8.625*	19.477	1.295*	4.276	3.241*			52.95	9.67
		2.575	8.617	19.846	1.383	4.291	3.232			56.48	1.27
		2.657	9.400	19.987	1.394*					60.20	1.38
		2.832	1.117 x 10 ⁻⁸ *	20.110	1.397					64.16	1.55
		2.843	1.104*							67.90	1.71
		2.847	1.136							71.49	1.92
		2.860	1.090							75.17	2.09
		2.954	2.027*							78.50	2.32
		1.537	2.028							82.39	2.46
		1.545	2.477							89.52	2.83
		1.549	2.307*							100.39	3.43
		1.553	2.432*							106.59	3.61
		1.583	2.519							112.49	3.94
		1.595	2.617							123.88	4.72
		1.603	2.589*							129.43	5.06
		1.620	2.397*							135.19	5.45
		1.652	2.722							140.57	5.75
		1.677	3.089							146.37	6.18
		1.683	2.770							152.42	6.68
		1.687	2.859*							158.23	7.01
		1.689	2.899*							163.93	7.55
		1.73-	3.315							169.40	7.88
		1.735	3.132*							177.55	8.37
		1.750	3.256*							183.60	8.62
		1.788	3.252*							189.24	9.25
		1.794	3.497							200.81	1.006 x 10 ⁻¹
		1.827	3.544*							206.11	1.036
		1.831	3.540							211.10	1.087
		1.847	3.725*								
		1.849	3.522*								
		1.889	3.844								

CURVE 16		CURVE 17	
T	Cp	T	Cp
0.3747	3.65 x 10 ⁻⁷	0.4546	4.88 x 10 ⁻⁷
0.4401	4.87	0.4918	5.81
0.5217	6.74	0.5287	6.77
0.6194	9.43	0.5981	5.98
0.7252	1.313 x 10 ⁻⁶	0.6479	1.071 x 10 ⁻⁶
0.8186	1.690	0.7298	1.371
1.0138	2.697	0.8237	1.819
1.1425	3.487	0.9116	2.301
1.4414	5.772	0.9766	2.669
1.5445	6.696	1.0578	3.159
1.7809	9.156*	1.1500	3.814
1.9151	1.079 x 10 ⁻⁵	1.2467	4.568
2.0068	1.191	1.3786	5.774
		1.5620	7.758
		1.7717	1.024 x 10 ⁻⁵
		2.0134	1.395

CURVE 14		CURVE 13	
T	Cp	T	Cp
0.3816	1.36 x 10 ⁻⁷	0.3816	1.36 x 10 ⁻⁷
0.4090	1.51	0.4090	1.51
0.4250	1.59	0.4250	1.59
0.4475	1.63	0.4475	1.63
0.4613	1.70	0.4613	1.70
0.5011	1.81	0.5011	1.81
0.5404	2.07	0.5404	2.07
0.5905	2.35	0.5905	2.35
0.6352	2.73	0.6352	2.73
0.6686	3.12	0.6686	3.12
0.7214	4.07	0.7214	4.07
0.7571	4.46	0.7571	4.46
0.8089	5.16	0.8089	5.16
0.8419	5.62	0.8419	5.62
0.8879	6.14	0.8879	6.14
0.9429	7.20	0.9429	7.20
1.0095	8.44	1.0095	8.44
1.0899	1.001 x 10 ⁻⁶	1.0899	1.001 x 10 ⁻⁶
1.1563	1.158	1.1563	1.158
1.2507	1.372	1.2507	1.372
1.3516	1.680	1.3516	1.680
1.4644	2.039	1.4644	2.039
1.6636	2.769	1.6636	2.769
1.8722	3.632	1.8722	3.632
2.350	6.571	2.350	6.571

* Not shown on plot

DATA TABLE NO. 2-B (continued)

T	Cp	T	Cp	T	Cp	T	Cp
<u>CURVE 18 (contd)</u>							
215.80	1.099 x 10 ⁻¹	373	1.80 x 10 ⁻¹	80.91	2.71 x 10 ⁻²	17.70	1.12 x 10 ⁻³
220.40	1.157	366	2.26	85.56	2.94	18.46	1.45
225.30	1.165	478	2.75	85.68	2.95	21.65	1.67
230.44	1.213	589	3.18	90.28	3.17	23.45	1.94
235.55	1.252	700	3.54	91.15	3.24	25.47	2.22
240.48	1.291	811	3.85	94.90	3.42	27.92	2.62
245.20	1.322	922	4.09	95.39	3.46	31.55	3.02
249.33	1.348	1033	4.28	101.21	3.77	33.31	4.48
254.34	1.388	1144	4.40	106.36	4.06	35.76	5.02
259.69	1.421	1255	4.46	111.19	4.33	38.64	6.39
264.92	1.473	1366	4.46	116.14	4.68	41.63	7.19
269.89	1.507	1478	4.40	118.22	4.79	44.75	8.12
271.49	1.513*	1589	4.28	121.08	4.94	47.87	8.83
275.53	1.539	1700	4.10	127.74	5.32	51.66	1.17 x 10 ⁻²
279.94	1.572*	1811	3.86	132.64	5.68	55.67	1.20
282.37	1.589*	1922	3.71	137.56	5.98	59.78	1.42
284.07	1.602	1366	3.55	141.65	6.28	63.94	1.61
286.99	1.625*	1478	3.55	147.05	6.61	68.06	1.70
291.21	1.659	1589	3.71	152.61	7.15	72.14	1.93
293.22	1.652*	1700	3.55	158.01	7.56	76.11	2.22
294.71	1.683*	1811	3.55	163.40	7.98	83.14	2.53
296.95	1.684*	1922	3.55	169.29	8.46	88.05	2.72
299.02	1.702*	12.82	1.14 x 10 ⁻³	175.14	8.70	93.06	3.02
300.57	1.714	13.99	1.42	181.23	9.20	97.88	3.15
<u>CURVE 21*</u>							
		14.68	1.51	187.63	9.68	107.48	3.41
		15.22	1.61	194.03	1.013 x 10 ⁻¹	106.86	3.68
		16.02	1.82	200.40	1.058	111.16	3.90
		16.44	1.86	206.87	1.108	115.93	4.12
		17.86	2.21	212.77	1.221	120.92	4.47
		18.07	2.20	218.87	1.303	125.96	4.67
		20.05	2.39	224.73	1.378	130.37	5.00
		20.23	2.49	230.87	1.410	134.89	5.19
		22.48	2.76	236.57	1.501	139.32	5.42
		27.08	4.18	242.73	1.563	143.90	5.66
		29.38	4.95	248.60	1.610	148.51	6.01
		31.26	5.25	259.51	1.638	156.61	6.58
		34.37	7.09	268.23	1.674	169.88	7.19
		37.04	7.37	275.71	1.727	178.12	7.95
		39.74	8.83	279.25	1.638	189.64	8.62
		42.48	9.33	282.65	1.674	195.16	8.72
		45.60	1.06 x 10 ⁻²	286.22	1.727	202.28	9.32
		49.42	1.13	289.90	1.772	208.75	9.77
		53.55	1.41	296.59	1.792	216.79	1.032 x 10 ⁻¹
		57.45	1.51	300.25	1.827	223.28	1.070
		61.02	1.74	303.68	1.827	229.27	1.097
		68.15	1.96			233.61	1.150
		72.20	2.24			235.64	1.147
		76.46	2.51				
		80.69	2.69				
<u>CURVE 19</u>							
273	1.98 x 10 ⁻¹						
366	2.38						
478	2.81						
589	3.18						
700	3.51						
811	3.78						
922	4.00						
1033	4.17						
1144	4.28						
1255	4.35						
1365	4.36						
1478	4.32						
1589	4.23						
1700	4.08						
1811	3.88						
1866	3.77						
1922	3.64						

* Not shown on plot

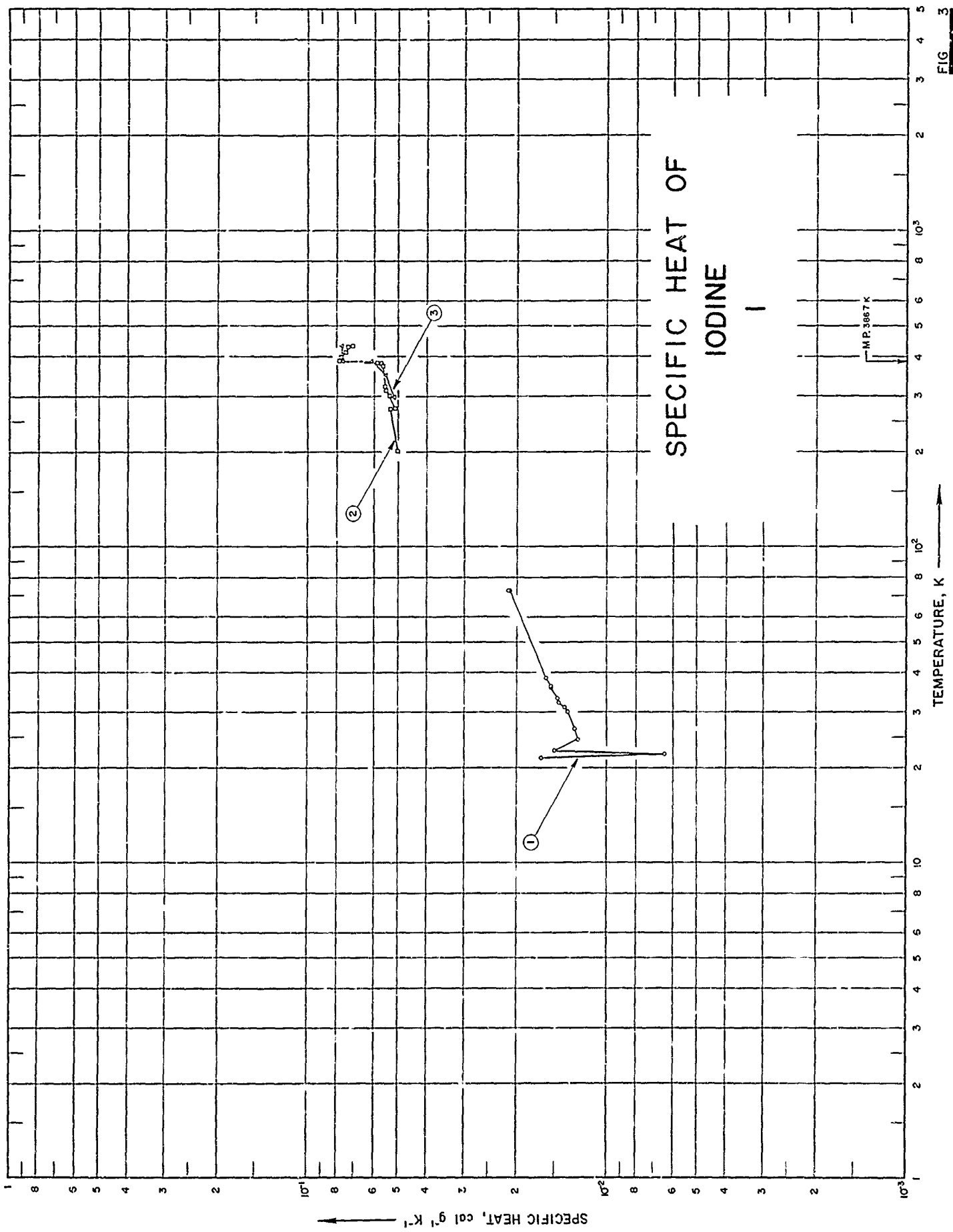

SPECIFICATION TABLE NO. 3 SPECIFIC HEAT OF IODINE

(Impurity <2.00% each; total impurities <5.00%)

[For Data Reported in Figure and Table No. 3]

Curve No.	Ref. No.	Year	Temp. Range, K	Reported Error, %	Name and Specimen Designation	Composition (weight percent), Specifications and Remarks
1	453	1916	22-73			
2	454	1936	202-433			
3	455	1938	298-433			Merck reagent; purified.

DATA TABLE NO. 3 SPECIFIC HEAT OF IODINE
 [Temperature, T, K; Specific Heat, C_p , Cal g⁻¹ K⁻¹]

T	C_p	T	C_p
<u>CURVE 1</u>		<u>CURVE 3</u>	
Series 1		Series 3	
	6.422×10^{-3}	298.15	5.153×10^{-2}
22.0	1.351×10^{-2}	300	5.153*
30.0	1.458	350	5.495
32.2	1.548	(s) 386.75	6.150
36.4	1.592	(t) 386.75	7.693
38.5		400	7.683*
		433	7.683
Series 2			
21.5	1.663×10^{-2}		
22.7	1.489		
24.6	1.257		
26.5	1.288		
28.6	1.422		
31.0	1.391		
33.2	1.466		
35.9	1.540		
72.9	2.120		
72.9	2.147		
<u>CURVE 2</u>			
202.2	5.00×10^{-2}		
202.9	5.05*		
274.6	5.31		
275.1	5.12		
275.3	5.23*		
275.5	5.20*		
301.5	5.34		
301.9	5.40*		
314.8	5.48		
315.0	5.49*		
322.8	5.52		
348.7	5.60*		
375.7	5.61		
380.3	5.70		
383.2	5.92		
389.4	7.88		
398.8	7.77		
413.2	7.48		
413.9	7.37		
432.7	7.10		

* Not shown on plot

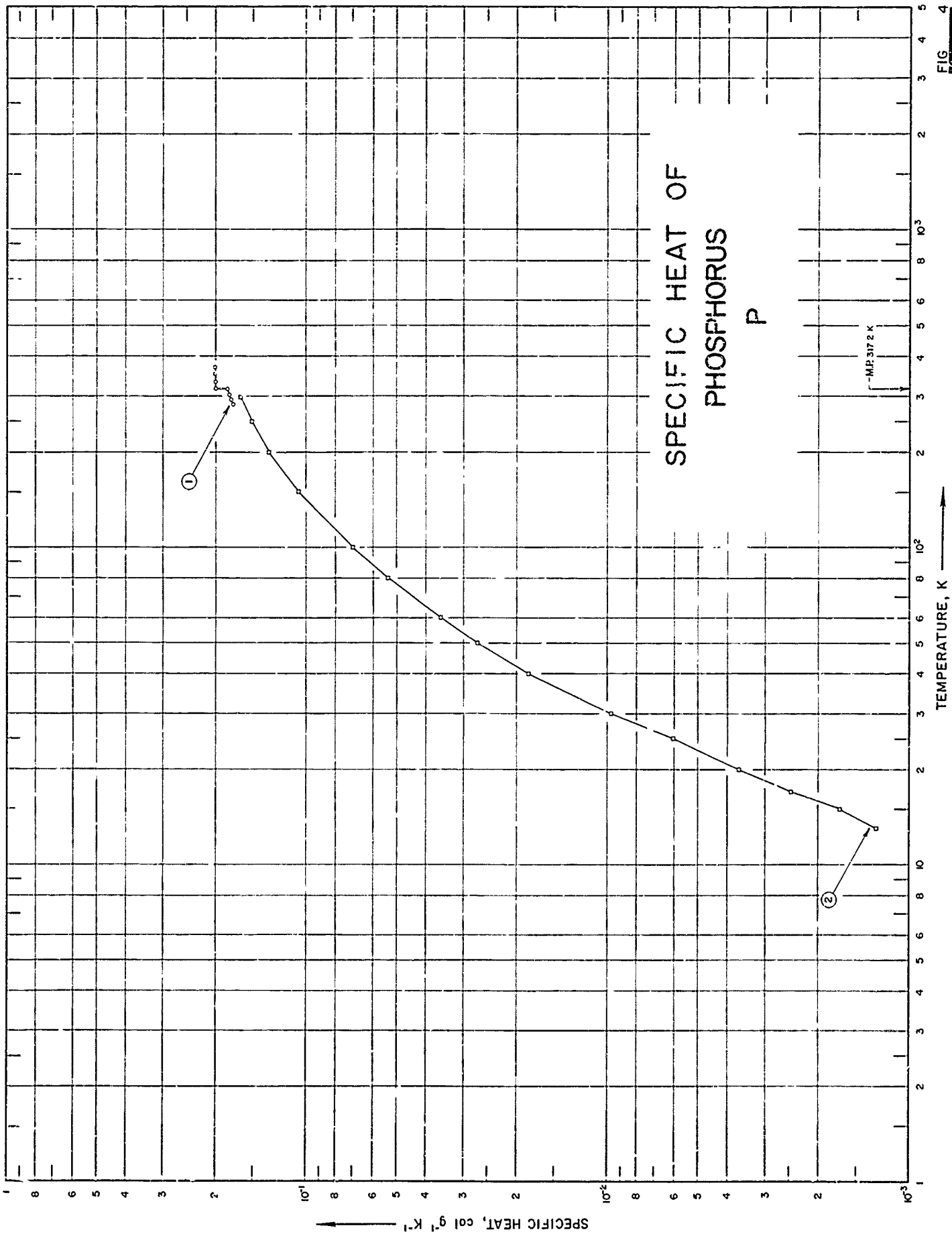

FIG. 4

SPECIFICATION TABLE NO. 4 SPECIFIC HEAT OF PHOSPHORUS

(Impurity < 2.00% each; total impurities < 5.00)

[For Data Reported in Figure and Table No. 4 J

Curve No.	Ref. No.	Year	Temp. Range, K	Reported Error, %	Name and Specimen Designation	Composition (weight percent), Specifications and Remarks
1	456	1942	283-370			
2	457	1965	13-298		Black Phosphorus	99.12 P, ~0.3 C and ~0.3 Pb.

DATA TABLE NO. 4 SPECIFIC HEAT OF PHOSPHORUS
 [Temperature, T, K; Specific Heat, C_p , Cal $g^{-1} K^{-1}$]

T	C_p
<u>CURVE 1</u>	
283.15	1.754×10^{-1}
293.15	1.777
303.15	1.800
(s) 317.35	1.833
(t) 317.35	2.002
323.15	2.004*
333.15	2.009
343.15	2.012*
353.15	2.015
363.15	2.017*
370.15	2.019
<u>CURVE 2</u>	
13	1.28×10^{-3}
15	1.69
17	2.45
20	3.664
25	6.028
30	9.715
40	1.825×10^{-2}
50	2.700
60	3.577
80	5.353
100	6.993
150	1.064×10^{-1}
200	1.336
250	1.513
298.15	1.665

* Not shown on plot

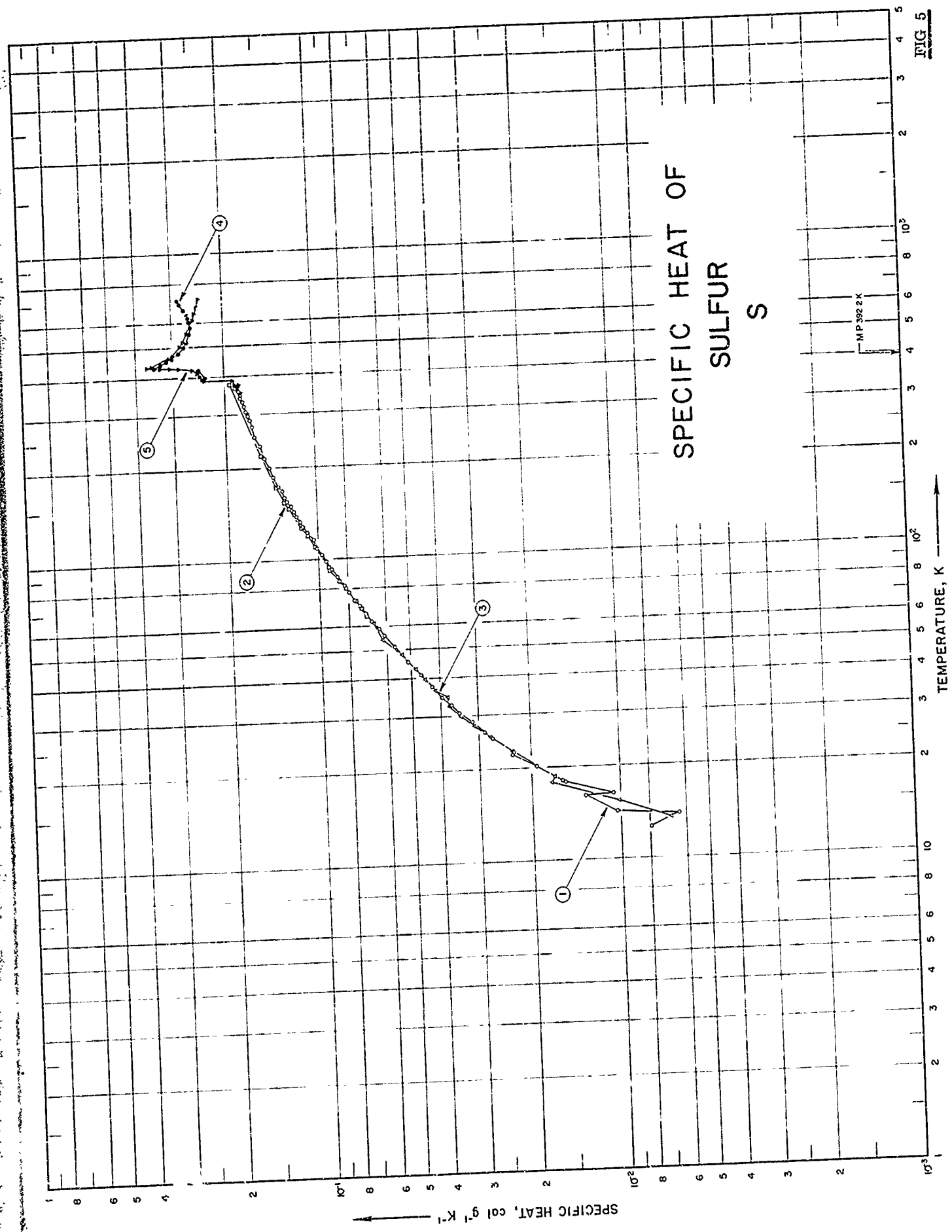

FIG 5

SPECIFICATION TABLE NO. 5 SPECIFIC HEAT OF SULFUR
(Impurity < 2.00% each; total impurities < 5.00)

[For Data Reported in Figure and Table No. 5.]

Curve No.	Ref. No.	Year	Temp. Range, K	Reported Error, %	Name and Specimen Designation	Composition (weight percent), Specifications and Remarks
1	450	1937	13-366	0.5	Rhombohedral	0.001 CS ₂ ; pure crystallized commercial product melted and maintained at 120 C for several days; distilled in Pyrex Glass and recrystallized; freed of CS ₂ by heating at 85 ± 5 C at 1 mm pressure for 8 days.
2	450	1927	65-376	0.5	Monoclinic	Same as above.
3	450	1937	14-61	0.5		A mixture of 60% monoclinic form and 40% rhombic form.
4	451	1954	333-713			
5	452	1959	303-718	0.1-0.2	Rhombohedral	99.999 S; sample supplied by NBS.

DATA TABLE NO. 5 SPECIFIC HEAT OF SULFUR

[Temperature, T, K; Specific Heat, C_p , Cal. g⁻¹K⁻¹]

CURVE 1		CURVE 1 (cont.)		CURVE 1 (cont.)		CURVE 2		CURVE 4 (cont.)		CURVE 5 (cont.)	
T	C_p	T	C_p	T	C_p	T	C_p	T	C_p	T	C_p
12.68	7.923×10^{-3}	128.63	1.125×10^{-1}	257.12	1.600×10^{-2}	04.83	6.993×10^{-2}	433	3.47×10^{-1}	388.357	1.888×10^{-1}
13.85	6.363	132.02	1.149*	258.85	1.604*	68.82	7.268	443	3.28	388.357	2.364
14.26	1.032×10^{-2}	133.29	1.152	263.79	1.623*	72.82	7.583	453	3.14	393	2.384
16.13	1.323	134.02	1.163*	265.93	1.619*	80.12	8.178	463	3.02	403	2.425
16.33	1.064	137.45	1.172*	272.91	1.634	84.76	8.559	473	2.92*	403	2.475
17.99	1.541	139.32	1.182	280.15	1.648*	91.98	9.138	483	2.82*	423	2.569
18.16	1.575	139.63	1.177*	280.47	1.652*	94.31	9.283	493	2.79*	429	2.854
20.26	1.925	144.50	1.205	287.32	1.663	98.25	9.573*	503	2.74	430	3.054
20.27	1.968*	145.01	1.207*	289.12	1.661*	102.55	9.825*	513	2.70*	431	3.314
22.23	2.311	150.39	1.233	289.26	1.659*	110.08	1.027 x 10 ⁻¹	523	2.67	432	3.616*
22.61	2.283	150.40	1.234*	290.17	1.679*	119.59	1.086	533	2.64*	433	3.671
25.18	2.692	150.40	1.234*	295.48	1.672*	127.24	1.136	543	2.62*	434	3.629*
26.38	2.860	152.21	1.252*	296.46	1.660*	147.42	1.256	553	2.61	435	3.581
28.66	3.157	155.44	1.272	296.55	1.685	154.91	1.297	563	2.60*	436	3.529*
30.71	3.475	157.92	1.277*	297.71	1.658*	172.41	1.374	573	2.59*	437	3.490*
32.62	3.687	160.16	1.296	298.28	1.673*	219.80	1.538	583	2.59	443	3.325*
34.68	3.974	163.26	1.303*	301.40	1.690*	375.14	1.924*	593	2.59*	453	3.165*
37.70	4.286	165.08	1.313*	302.32	1.689*	376.16	1.926	603	2.60	463	3.064
41.10	4.660	165.31	1.316*	303.97	1.689*			613	2.61*	473	2.984
45.39	5.122	167.75	1.319	306.13	1.705			623	2.62	483	2.918*
51.99	6.132	169.50	1.333*	311.46	1.718*			633	2.64*	493	2.864*
55.90	6.379	174.26	1.331*	312.42	1.720*			643	2.66	503	2.818
59.82	6.482*	174.76	1.354	319.98	1.740			653	2.68*	513	2.779*
62.54	6.755	180.25	1.366*	320.92	1.745*			663	2.70	523	2.742
63.99	6.828*	181.33	1.360*	323.17	1.744*			673	2.73*	533	2.710*
66.33	7.013	187.56	1.401	324.37	1.762*			683	2.76*	543	2.681*
68.84	7.286*	188.86	1.417*	325.87	1.763*			693	2.79	553	2.654
70.04	7.352	194.00	1.423*	330.34	1.749			703	2.82*	563	2.639*
73.22	7.651	200.83	1.448	331.32	1.775*			713	2.85	573	2.607*
74.04	7.655*	202.25	1.462*	335.76	1.734*			593	2.87*	583	2.587*
74.61	7.648*	207.38	1.466*	338.11	1.770*			603	2.569*	593	2.569*
78.12	7.966	208.25	1.479*	340.22	1.777			613	1.699 x 10 ⁻¹	603	2.533*
82.44	8.278	214.59	1.475*	344.16	1.765*			623	1.716*	613	2.538
87.66	8.706	215.69	1.495	346.87	1.787*			633	1.733*	623	2.525*
92.81	9.092	220.99	1.513*	347.86	1.801*			643	1.749*	633	2.513*
96.29	9.323*	222.50	1.518*	353.74	1.790*			653	1.765*	643	2.502
98.83	9.438	226.56	1.528*	357.23	1.806			663	1.780	653	2.491*
100.83	9.626*	229.53	1.536*	361.21	1.772*			673	1.795*	663	2.480*
103.92	9.782	236.46	1.547	364.02	1.851*			683	1.802	673	2.469*
105.25	9.838*	236.51	1.555*	364.59	1.769*			693	1.844*	683	2.457
109.80	1.013 x 10 ⁻¹	244.79	1.577*	365.60	1.854			303	1.803*	693	2.443*
117.13	1.044	249.02	1.585*					313	1.789	703	2.428*
122.76	1.094	253.63	1.605					323	1.749*	713	2.409*
								333	1.749*	717.75	2.400
								343	1.765*		
								353	1.780		
								363	1.795*		
								368.54	1.802		
								373	1.844*		
								374	1.803*		
								374	1.789		
								374	1.858		
								423	1.877*		

* Not shown on plot

FIGURE SHOWS ONLY 13 OF THE CURVES REPORTED IN TABLE

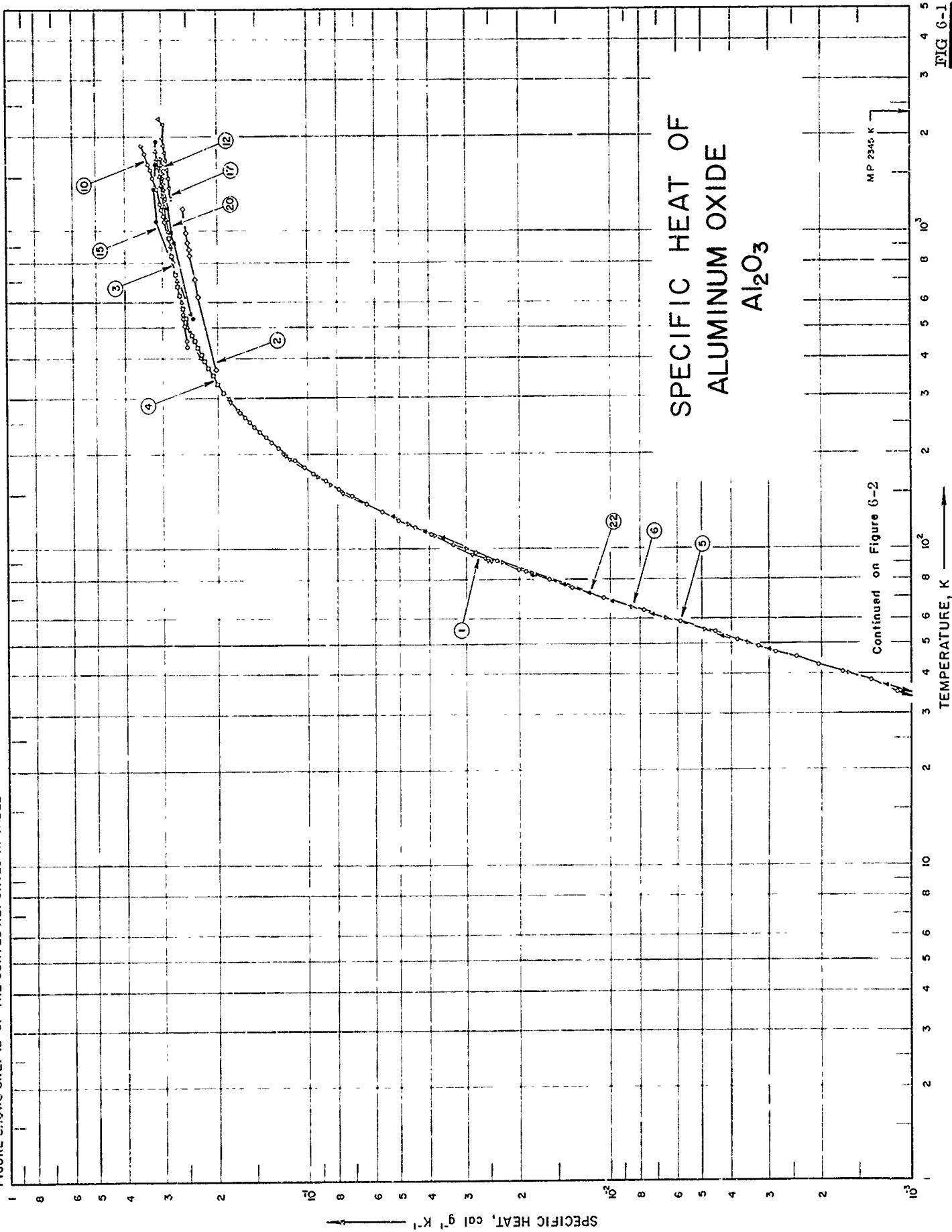
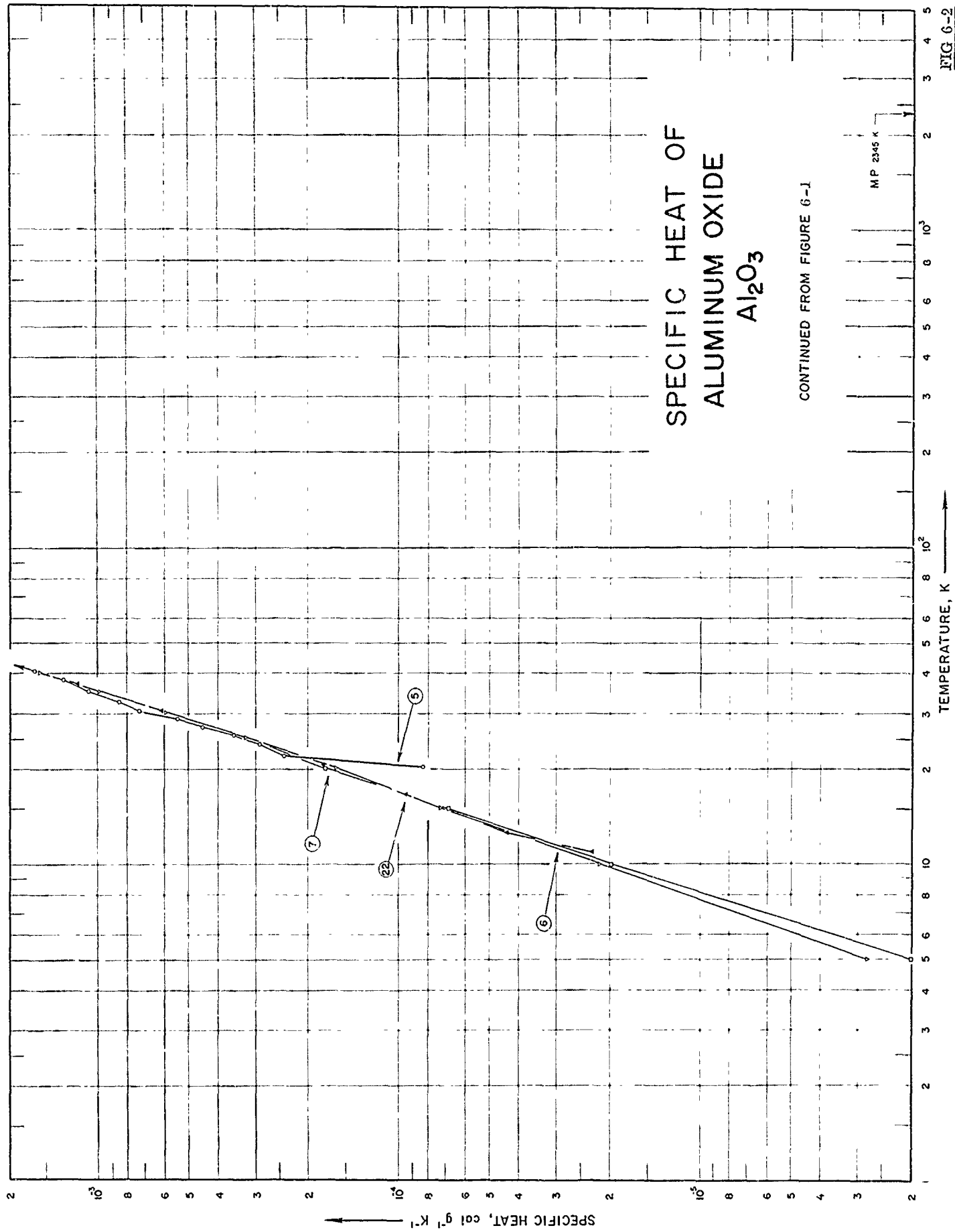

FIG 6-1

SPECIFIC HEAT OF ALUMINUM OXIDE Al_2O_3

CONTINUED FROM FIGURE 6-1



SPECIFICATION TABLE NO. 6 SPECIFIC HEAT OF ALUMINUM OXIDE Al_2O_3

[For Data Reported in Figure and Table No. 6]

Curve No.	Ref. No.	Year	Temp. Range, K	Reported Error, %	Name and Specimen Designation	Composition (weight percent), Specifications and Remarks
1	18	1926	91-291			99.3 Al_2O_3 .
2	19	1929	369-1187			Sapphire.
3	20	1945	298-1800	± 0.4		100 Al_2O_3 ; natural almost colorless sapphire.
4	21	1947	273-1173	1.0-2		Corundum, synthetic sapphire; 0.02 - 0.03 impurities mostly SiO_2 .
5	22	1950	20-295			Synthetic sapphire; 0.02 SiO_2 .
6	23	1953	5-1200	0.2		Corundum, synthetic sapphire; 0.01 - 0.02 impurities.
7	24	1956	5-1200	0.2		Corundum, synthetic sapphire; 99.98 Al_2O_3 , 0.005 each Fe, Si, and 0.002 Cr.
8	25	1956	337-523			Synthetic sapphire; calorimetric standard.
9	26	1958	312-689			Pure Al_2O_3 .
10	27	1958	435-1884	2.9		Al_2O_3 ; polycrystalline.
11	28	1960	65-300			α - Al_2O_3 .
12	29	1960	1089-1700			Synthetic sapphire.
13	30	1960	325-986	0.5		99.997 Al_2O_3 , 0.0013 Cr, 0.001 Fe, 0.001 Mo, and 0.0004 Cu.
14	31	1960	533-1228	2.9		Synthetic sapphire.
15	32	1962	533-1922	≤ 5.0		100 Al_2O_3 ; density 233 lb ft ⁻³ .
16	33	1961	342-764			Natl. Bur. Std. standard sample; scratched on 0.065 and treated with hot HCl to remove traces of Fe.
17	34	1961	1273-2273	1.3		Synthetic sapphire.
18	35	1962	53-291	± 0.10		Calorimetry conference synthetic sapphire.
19	36	1962	283-303	0.10		Calorimetry conference standard.
20	37	1963	552-1385			Synthetic sapphire.
21	38	1963	1300-2000	≤ 3.0		98.7 Al_2O_3 and 1.0 SiO_2 ; sintered; under argon atmosphere.
22	39	1965	10-353	0.1		Synthetic sapphire.

DATA TABLE NO. 6 (continued)

T	C _p	T	C _p	T	C _p	T	C _p	T	C _p	T	C _p		
100	3.010 × 10 ⁻²	320	1.957 × 10 ⁻¹	800	2.820 × 10 ⁻¹	660.05	2.702 × 10 ⁻¹	65	8.493 × 10 ⁻³	379.91	2.186 × 10 ⁻¹		
105	3.408	325	1.980	820	2.834	669.75	2.711	70	1.079 × 10 ⁻²	425.59	2.330		
110	3.826	330	2.002	840	2.846	676.35	2.721	80	1.611	455.63	2.334		
115	4.257	335	2.022	860	2.857	689.05	2.731	90	2.266	476.52	2.445		
120	4.702	340	2.044	880	2.868	CURVE 10 434.82 2.519 × 10 ⁻¹ 457.04 2.535 507.59 2.572 533.15 2.591 550.37 2.603 616.48 2.651* 627.59 2.659* 696.48 2.709* 750.38 2.748* 810.93 2.792* 837.04 2.810* 872.04 2.836* 892.04 2.851* 938.71 2.884* 1012.59 2.938* 1079.82 2.987 1088.71 2.992* 1123.71 3.018 1179.82 3.059 1239.26 3.102 1273.71 3.127* 1366.48 3.193 1413.15 3.228* 1486.48 3.281 1492.59 3.285* 1574.26 3.344 1644.26 3.395 1662.04 3.408* 1716.48 3.447 1763.71 3.481 1820.93 3.523* 1883.15 3.568		100	3.037	476.86	2.457		
125	5.155	345	2.064	900	2.879			120	4.708	110	3.835	478.52	2.522
130	5.617	350	2.083	920	2.889			120	4.708	120	4.708	522.47	2.522
135	6.083	360	2.122	940	2.898			130	5.649	130	5.649	524.48	2.522
140	6.554	370	2.158	960	2.907			140	6.591	140	6.591	473.98	2.618
145	7.02	380	2.191	980	2.916			150	7.513	150	7.513	575.89	2.623
150	7.495	390	2.224	1000	2.924			160	8.444	160	8.444	622.49	2.665
155	7.968	400	2.254	1020	2.932			170	9.395	170	9.395	624.52	2.665
160	8.436	410	2.283	1040	2.939			180	1.033 × 10 ⁻¹	180	1.033 × 10 ⁻¹	653.85	2.700
165	8.901	420	2.310	1060	2.946			190	1.123	190	1.123	673.16	2.733
170	9.362	430	2.336	1080	2.953			200	1.208	200	1.208	675.18	2.733
175	9.817	440	2.360	1100	2.959			210	1.289	210	1.289	726.61	2.780
180	1.026 × 10 ⁻¹	450	2.384	1120	2.966			220	1.365	220	1.365	728.66	2.768
185	1.071	460	2.405	1140	2.971			230	1.439	230	1.439	748.94	2.794
190	1.114	470	2.427	1160	2.977			240	1.512	240	1.512	750.93	2.789
195	1.156	480	2.447	1180	2.983	250	1.584	250	1.584	780.04	2.818		
200	1.199	490	2.467	1200	2.988	260	1.646	260	1.646	782.03	2.806		
205	1.240	500	2.486	1200	2.988	270	1.704	270	1.704	816.16	2.848		
210	1.280	510	2.503	337.35	2.020 × 10 ⁻¹	280	1.755	280	1.755	818.02	2.846		
215	1.319	520	2.521	423.55	2.315	290	1.817	290	1.817	850.45	2.853		
220	1.358	530	2.538	423.55	2.315	300	1.868	300	1.868	885.62	2.890		
225	1.395	540	2.553	523.15	2.530	337.35	2.020 × 10 ⁻¹	337.35	2.020 × 10 ⁻¹	887.59	2.890		
230	1.432	550	2.568	627.25	2.669	1088.9	2.956 × 10 ⁻¹	1088.9	2.956 × 10 ⁻¹	887.59	2.890		
235	1.468	560	2.583	627.25	2.669	1144.4	2.973*	1144.4	2.973*	887.59	2.890		
240	1.503	570	2.598	732.05	2.771	1200.0	2.987*	1200.0	2.987*	935.61	2.904		
245	1.538	580	2.611	825.05	2.848	1255.5	3.000*	1255.5	3.000*	986.36	2.930		
250	1.571	590	2.624	923.35	2.899	1311.1	3.012*	1311.1	3.012*	986.36	2.930		
255	1.603	600	2.637	923.35	2.899	1492.59	3.285*	1492.59	3.285*	986.82	2.937		
260	1.635	610	2.650	311.92	1.920 × 10 ⁻¹	1492.59	3.285*	1492.59	3.285*	533.15	2.63 × 10 ⁻¹		
265	1.666	620	2.661	321.65	1.964	1574.26	3.344	1574.26	3.344	672.04	2.72		
270	1.696	630	2.672	523.15	2.530	1644.26	3.395	1644.26	3.395	672.04	2.72		
275	1.715	640	2.684	627.25	2.669	1662.04	3.408*	1662.04	3.408*	810.93	2.80		
280	1.754	650	2.705	732.05	2.771	1716.48	3.447	1716.48	3.447	949.82	2.89		
285	1.782	660	2.715	825.05	2.848	1763.71	3.481	1763.71	3.481	1088.71	2.97		
290	1.809	670	2.725	923.35	2.899	1820.93	3.523*	1820.93	3.523*	1227.59	3.06		
295	1.836	680	2.734	923.35	2.899	1883.15	3.568	1883.15	3.568				
298.16	1.852	700	2.743	311.92	1.920 × 10 ⁻¹								
300	1.861	720	2.760	321.65	1.964								
305	1.886	740	2.777	331.35	2.008								
310	1.914	760	2.769	341.05	2.048								
315	1.934	780	2.807	350.65	2.086								

*Not shown on plot

DATA TABLE NO. 6 (continued)

T	Cp	T	Cp	T	Cp	T	Cp	T	Cp
<u>CURVE 16*</u>									
Series 1									
344	2.08 x 10 ⁻¹	1273.15	2.859 x 10 ⁻¹	1300	3.014 x 10 ⁻¹	551.95	2.46 x 10 ⁻¹	1350	3.012
380	2.27	1473.15	2.913	1350	3.012	920.65	2.79	1400	3.007
406	2.30	1573.15	2.941	1450	3.034	996.55	2.85	1450	3.034
436	2.37	1673.15	2.969	1500	3.047	1097.75	2.92*	1500	3.047
492	2.47	1773.15	2.996	1550	3.046	1190.25	2.92	1550	3.046
515	2.52	1873.15	3.024	1600	3.059	1282.55	3.04*	1600	3.059
544	2.57	1973.15	3.051	1650	3.067	1385.55	3.03*	1650	3.067
566	2.60	2173.15	3.016	1700	3.071	1385.55	3.03*	1700	3.071
591	2.63	2273.15	3.134	1750	3.074	1385.55	3.03*	1750	3.074
614	2.65	<u>CURVE 18*</u>							
638	2.66	53.377	4.375 x 10 ⁻³	1800	3.078	1385.55	3.03*	1800	3.078
662	2.68	56.621	5.353	1850	3.085	1385.55	3.03*	1850	3.085
685	2.71	59.604	6.342	1900	3.081	1385.55	3.03*	1900	3.081
703	2.73	62.273	7.392	1950	3.081	1385.55	3.03*	1950	3.081
721	2.75	66.033	8.915	2000	3.076	1385.55	3.03*	2000	3.076
740	2.78	68.349	9.998	<u>CURVE 22</u>					
762	2.81	85.703	1.989 x 10 ⁻²	Series 1					
Series 2									
342	2.04	89.379	2.242	10.908	2.344 x 10 ⁻⁵	12.554	4.454	162.907	8.624
378	2.19	91.860	2.417	12.554	4.454	16.613	9.611	169.569	9.337
405	2.28	94.004	2.566	16.613	9.611	20.606	1.828 x 10 ⁻⁴	177.166	1.067 x 10 ⁻¹
433	2.33	95.559	2.681	25.456	3.586*	25.456	3.586*	184.408	1.128
461	2.41	98.257	2.885	30.449	6.376	30.449	6.376	191.346	1.188
490	2.47	102.140	3.187	36.793	1.207 x 10 ⁻³	36.793	1.207 x 10 ⁻³	198.666	1.188
513	2.52	102.140	3.187	42.775	2.025*	42.775	2.025*	206.352	1.252
538	2.56	102.140	3.187	47.765	2.970	47.765	2.970	213.751	1.313
561	2.60	102.140	3.187	52.831	4.236	52.831	4.236	221.771	1.372
585	2.64	102.140	3.187	Series 2					
609	2.66	102.140	3.187	61.852	7.199	61.852	7.199	238.598	1.496
630	2.69	102.140	3.187	63.953	8.038*	63.953	8.038*		
653	2.71	102.140	3.187	67.952	9.782	67.952	9.782		
680	2.75	102.140	3.187						
701	2.78	102.140	3.187						
722	2.80	102.140	3.187						
743	2.84	102.140	3.187						
764	2.86	102.140	3.187						

* Not shown on plot

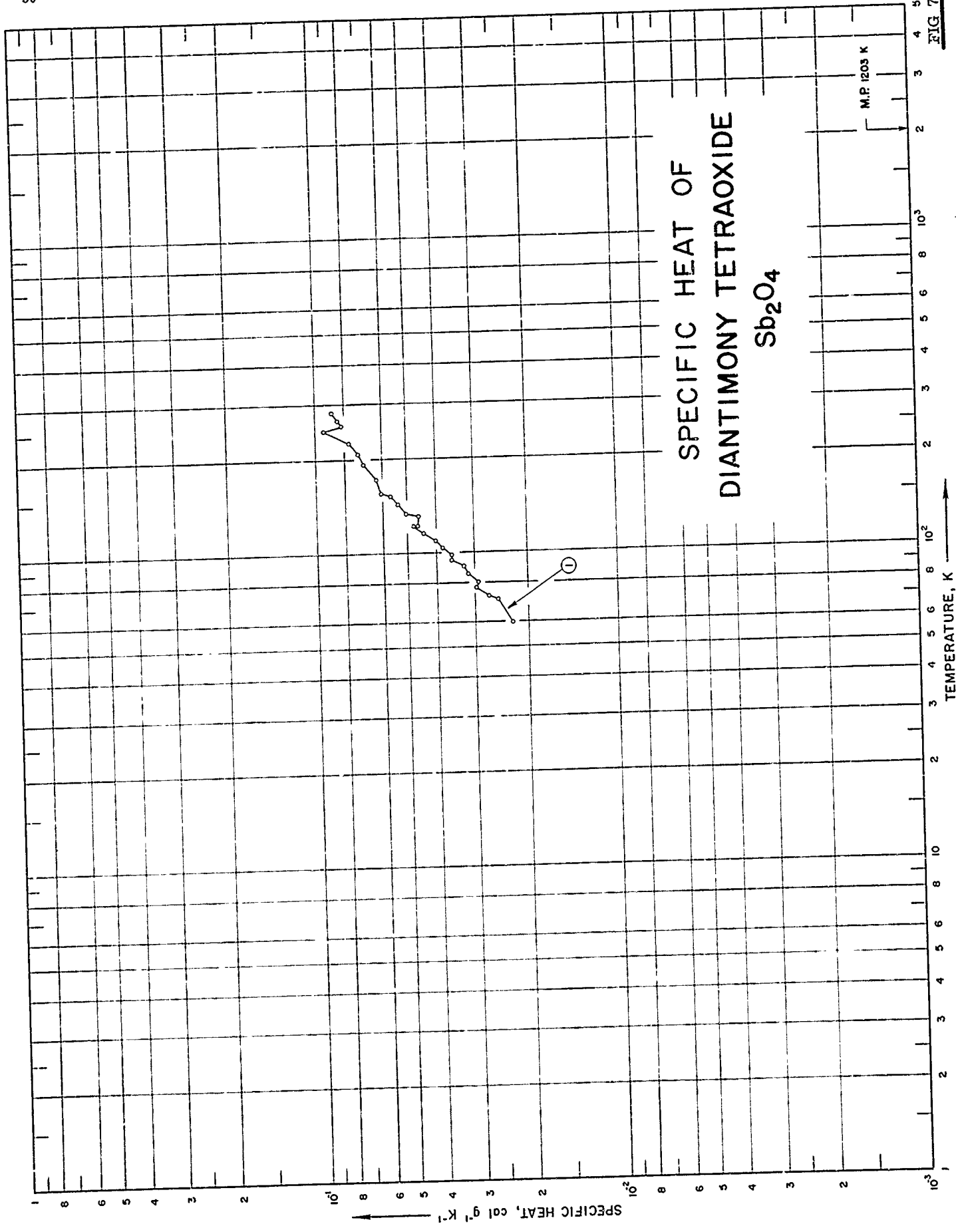

FIG. 7

SPECIFICATION TABLE NO. 7 SPECIFIC HEAT OF DIANTIMONY TETRACOXIDE Sb_2O_4

[For Data Reported in Figure and Table No. 7]

Curve No.	Ref. No.	Year	Temp. Range, K	Reported Error, %	Name and Specimen Designation	Composition (weight percent). Specifications and Remarks
1	40	1930	73-285	1		Correct ratio for Sb_2O_4 , prepared by boiling mixture of Sb_2O_3 and HNO_3 ; washed free of HNO_3 , dried, and heated at 850 C under vacuum; density 6.47 g cm^{-3} at 23.8 C.

DATA TABLE NO. 7 SPECIFIC HEAT OF DIANTIMONY TETRAOXIDE Sb_2O_4 [Temperature, T, K; Specific Heat, C_p , Cal g⁻¹ K⁻¹]

T	C_p
CURVE 1	
72.8	2.705 x 10 ⁻²
77.3	2.978
80.1	2.947
85.6	3.162
90.6	3.259
94.4	3.584
98.5	3.577
104.3	3.847
115.7	4.436
122.6	4.787
59.8	2.258
70.8	2.522
134.8	5.041
143.8	5.389
165.6	6.094
193.7	6.950
209.7	7.220
236.1	7.785
100.1	3.577*
103.7	3.743*
109.0	4.036
114.8	4.309*
118.8	4.472*
123.1	4.608
131.3	4.589
153.1	5.672
172.7	6.299
200.9	7.070*
229.3	7.707*
247.8	9.373
256.4	8.204
266.9	8.459
271.9	8.488*
278.8	8.618*
294.9	8.836

* Not shown on plot

SPECIFIC HEAT OF
DIANTIMONY PENTAOXIDE
 Sb_2O_5

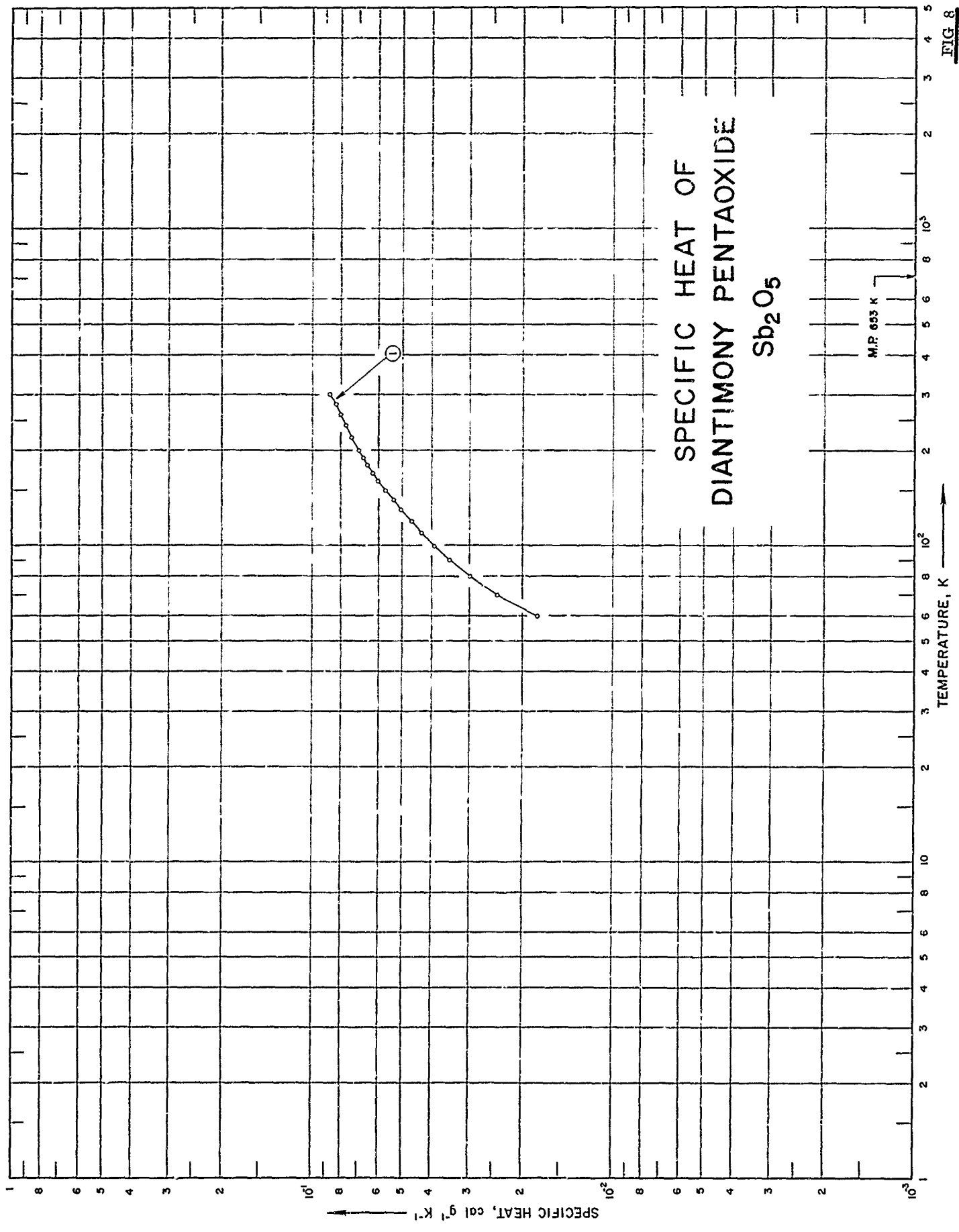

SPECIFICATION TABLE NO. 8 SPECIFIC HEAT OF DIANTIMONY PENTAOXIDE Sb_2O_5

[For Data Reported in Figure and Table No. 8]

Curve No.	Ref. No.	Year	Temp. Range, K	Reported Error, %	Name and Specimen Designation	Composition (weight percent), Specifications and Remarks
1	40	1930	60-300	1		Obtained from measurement of two hydrated samples.

DATA TABLE NO. 8 SPECIFIC HEAT OF DIANTIMONY PENTAOXIDE Sb_2O_5 [Temperature, T, K; Specific Heat, C_p , Cal $g^{-1} K^{-1}$]

T	C_p
<u>CURVE 1</u>	
60	1.777 x 10 ⁻²
70	2.420
80	2.986
90	3.487
100	3.913
110	4.328
120	4.689
130	5.036
140	5.376
150	5.706
160	6.006
170	6.281
180	6.547
190	6.785
200	7.008
210	7.212*
220	7.416
230	7.601*
240	7.756
250	7.901*
260	8.046
270	8.204*
280	8.368
290	8.538*
300	8.726

* Not shown on plot

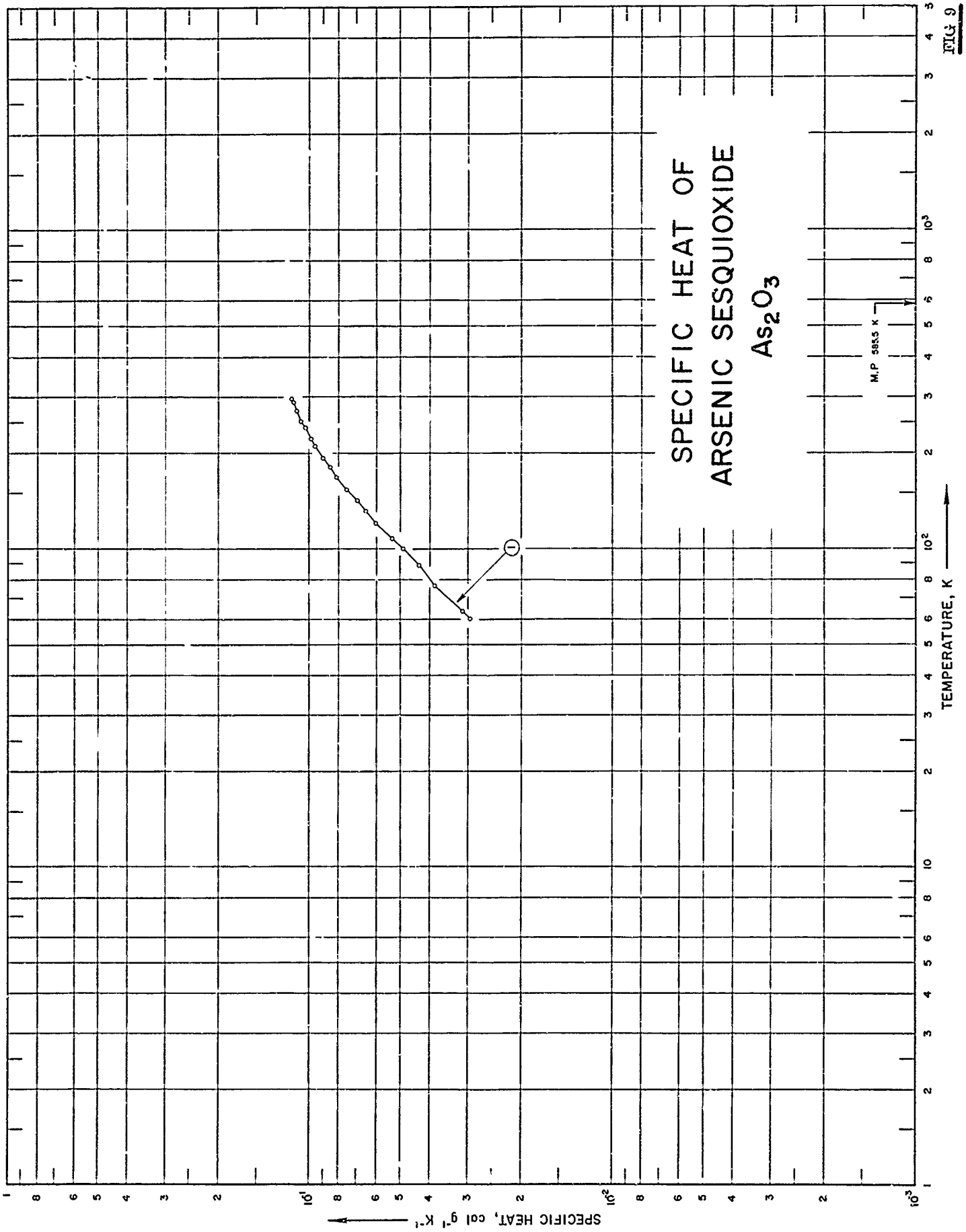

FIG. 9

SPECIFICATION TABLE NO. 9 SPECIFIC HEAT OF ARSENIC SESQUIOXIDE As_2O_3

[For Data Reported in Figure and Table No. 9]

Curve No.	Ref. No.	Year	Temp. Range, K	Reported Error, %	Name and Specimen Designation	Composition (weight percent), Specifications and Remarks
1	104	1930	60-296			>99.8 As_2O_3 ; crystalline of octahedral structure; density 3.85 g cm^{-3} .

DATA TABLE NO. 9 SPECIFIC HEAT OF ARSENIC SESQUIOXIDE As_2O_3 [Temperature, T, K; Specific Heat, C_p , Cal $\text{g}^{-1} \text{K}^{-1}$]

T	C_p
	<u>CURVE 1</u>
60.2	2.950×10^{-2}
63.9	3.133
76.9	3.863
89.0	4.369
100.0	4.902
108.1	5.330
121.1	6.053
132.0	6.543
143.0	6.973
154.9	7.528
168.9	8.155
181.0	8.549
194.7	9.059
210.4	9.600
223.0	9.893
241.9	1.035×10^{-1}
253.7	1.073
272.2	1.103
288.7	1.135
291.6	1.142*
296.6	1.151

*Not shown on plot

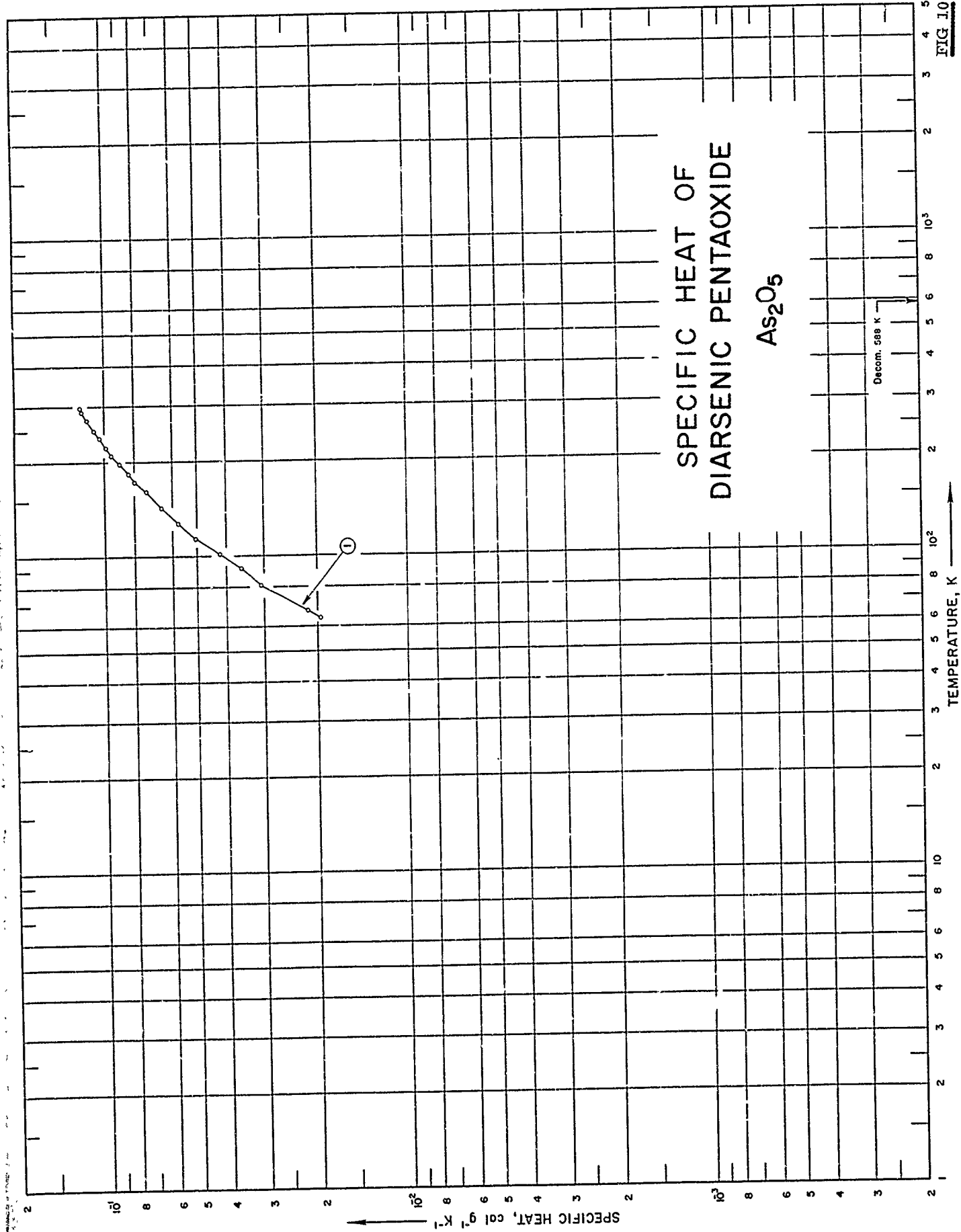

FIG 10

SPECIFICATION TABLE NO. 10 SPECIFIC HEAT OF DIARSENIC PENTAOXIDE As_2O_5

[For Data Reported in Figure and Table No. 10]

Curve No.	Ref. No.	Year	Temp. Range, K	Reported Error, %	Name and Specimen Designation	Composition (weight percent), Specifications and Remarks
1	309	1930	63-296			>99.7 As_2O_5 and 0.2 As_2O_3 ; crystalline aggregates; density 4.32 g cm ⁻³ .

DATA TABLE NO. 10 SPECIFIC HEAT OF DIARSENIC PENTAOXIDE As₂O₅

[Temperature, T, K; Specific Heat, C_p, Cal g⁻¹ K⁻¹]

T	C _p
	<u>CURVE 1</u>
63.5	1.962 x 10 ⁻²
67.1	2.152
80.8	3.088
91.6	3.595
101.9	4.224
114.0	5.032
127.8	5.789
143.5	6.568
160.9	7.298
168.5	7.790*
173.2	8.007
181.5	8.386*
184.1	8.390
196.9	9.003
209.8	9.521
222.0	9.947
239.1	1.048 x 10 ⁻¹
251.1	1.091
270.3	1.153
287.1	1.194
291.7	1.204*
296.2	1.204

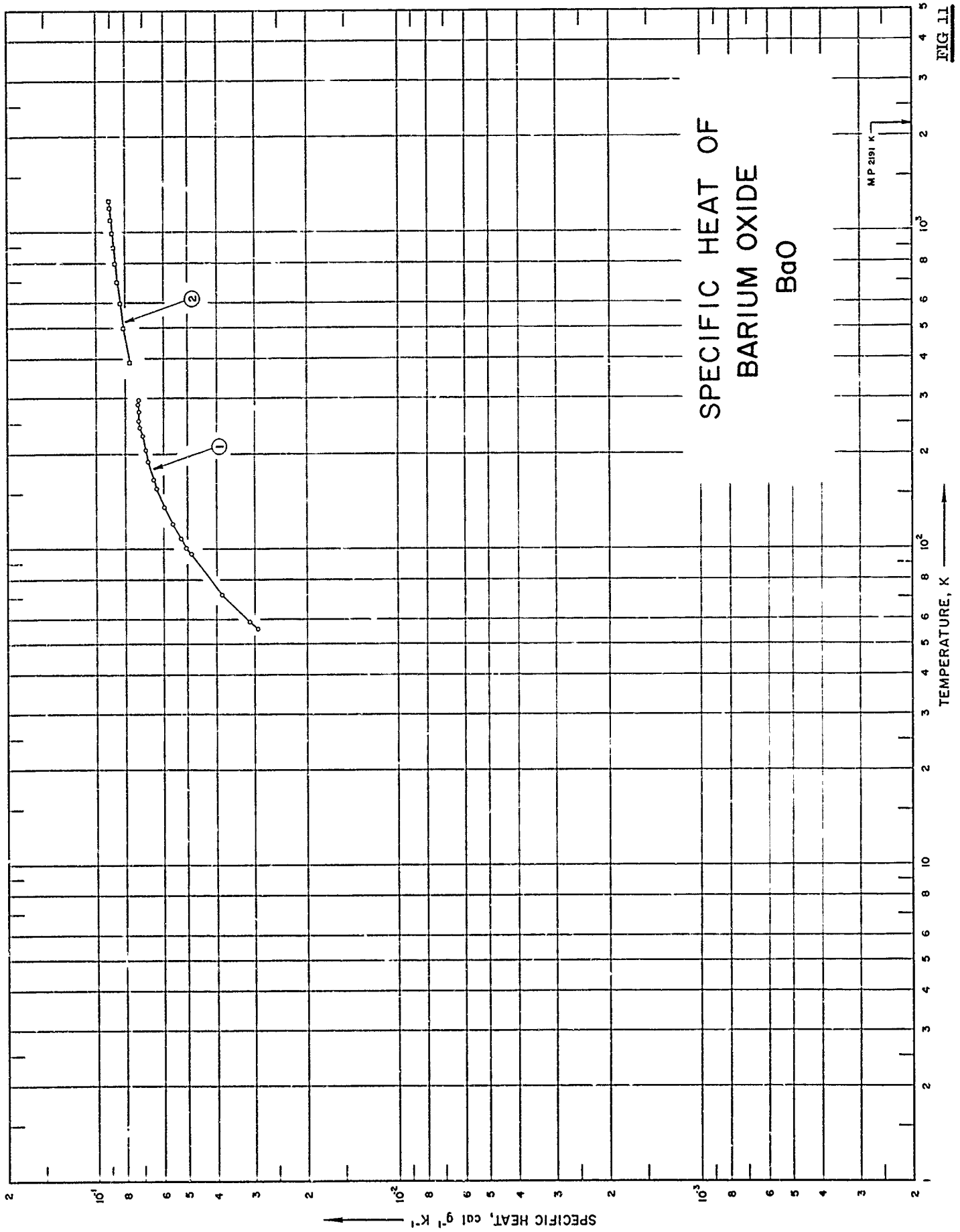

FIG 11

SPECIFICATION TABLE NO. 11 SPECIFIC HEAT OF BARIUM OXIDE BaO

[For Data Reported in Figure and Table No. 11]

Curve No.	Ref. No.	Year	Temp. Range, K	Reported Error, %	Name and Specimen Designation	Composition (weight percent), Specifications and Remarks
1	41	1935	56-299			Kahlbaum best grade.
2	42	1951	390-1262			99 BaO; and ~1 SiO ₂ .

DATA TABLE NO. 11 SPECIFIC HEAT OF BARIUM OXIDE BaO

[Temperature, T, K; Specific Heat, C_p , Cal g⁻¹ K⁻¹]

T	C_p
<u>CURVE 1</u>	
56.1	2.912 x 10 ⁻²
59.2	3.104
72.1	3.845
97.0	4.870
101.5	5.027*
102.8	5.075*
109.1	5.267
120.6	5.602
136.6	5.956
156.2	6.322
166.8	6.471
190.2	6.742
207.1	6.879
230.1	7.010
230.5	7.107*
244.2	7.205
250.1	7.199*
255.7	7.225
259.4	7.244*
274.3	7.218
287.6	7.296
298.6	7.244
<u>CURVE 2</u>	
390	7.721 x 10 ⁻²
400	7.770*
500	8.129
600	8.355
700	8.518
800	8.648
900	8.758
1000	8.856
1100	8.946
1200	9.031
1262	9.082

* Not shown on plot

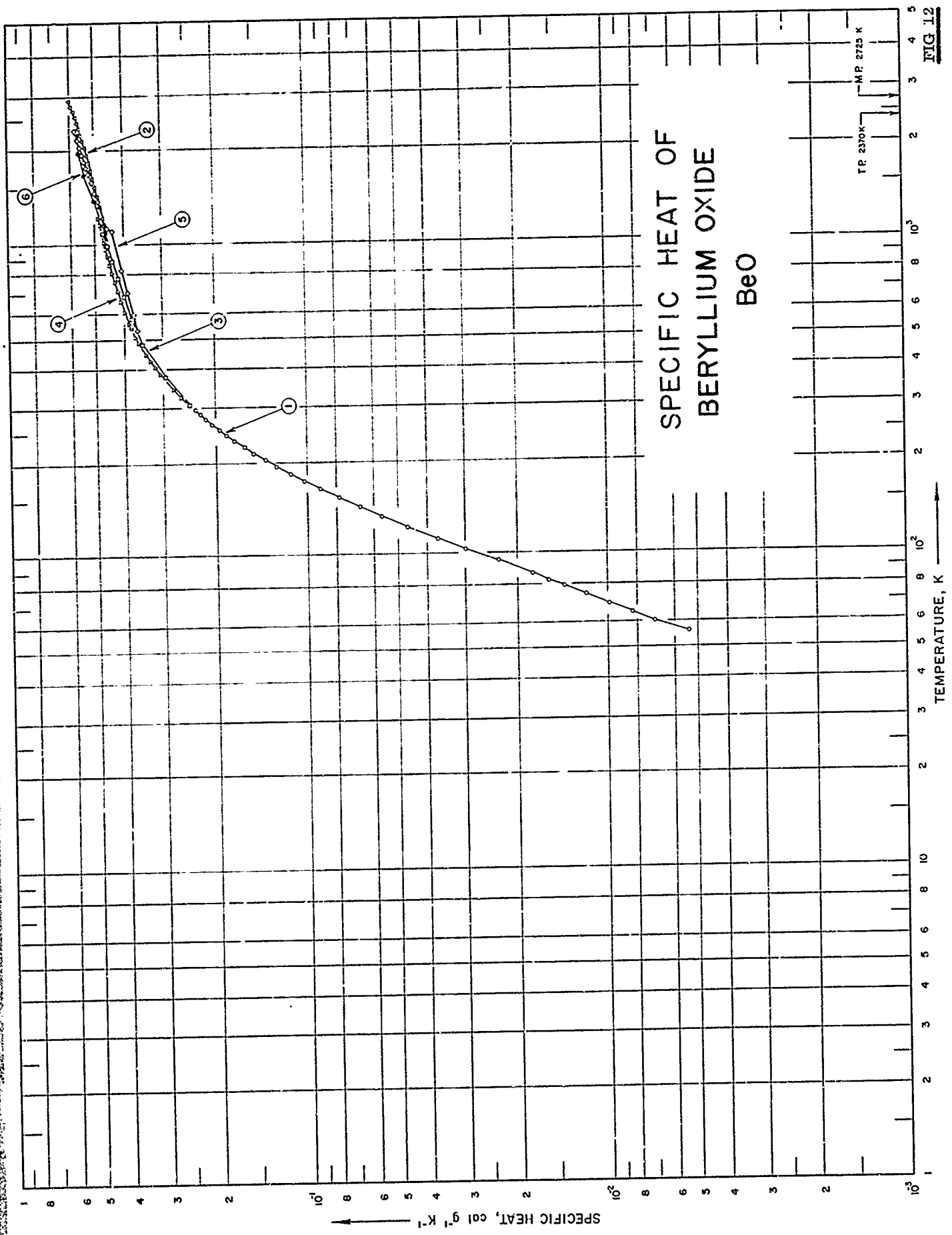

FIG. 12

SPECIFICATION TABLE NO. 12 SPECIFIC HEAT OF BERYLLIUM OXIDE BeO

[For Data Reported in Figure and Table No. 12 j

Curve No.	Ref. No.	Year	Temp. Range, K	Reported Error, %	Name and Specimen Designation	Composition (weight percent), Specifications and Remarks
1	43	1939	55-292			99.6 BeO.
2	44	1960	1200-2820	0.25-0.5		99.9 BeO, with impurities of Al, Ni, Cu, Zn, Ag, Fe, and Ti; pressed and sintered with 0.1 glucose as cementing substance at 1400-1800 C.
3	45	1962	303-1073	±3		
4	46	1963	298-1200	0.40		99.96 BeO, 0.01 Si, 0.007 Al, 0.002 K, 0.002 Na, 0.001 Cs, 0.001 Fe, <0.001 Ca, <0.001 Cu, <0.00005 Li, <0.00005 Mg; supplied by Norton Co.; pressed, fired at 1800 C and sintered.
5	47	1963	526-2280	±5		99.5 BeO, 0.01 Si, 0.005 Al, 0.002 Mo, 0.001 Ca, 0.001 Cr, 0.001 Fe, 0.001 Na, 0.001 Ni, 0.0003 Mn, ≤0.0001 B, Cd, Li, <0.0001 Co, Cu; supplied by Brush Beryllium Co.; cold pressed; density 179 lb ft ⁻³ .
6	48	1963	533-2200	±5		Sample supplied by Zirconium Corp. of America; crushed in hardened steel mortar to pass 100-mesh screen; pressed and sintered; density at 25 C before exposure; apparent density (AST M method B311-58) 183 lb ft ⁻³ , true density (by immersion in xylene) 187 lb ft ⁻³ .

DATA TABLE NO 12 SPECIFIC HEAT OF BERYLLIUM OXIDE BeO

[Temperature, T, K; Specific Heat, C_p, Cal g⁻¹K⁻¹]

T	C _p	T	C _p	T	C _p
55.5	5.356 x 10 ⁻³	2100	5.541 x 10 ⁻¹	950	4.659 x 10 ⁻¹ *
59.9	6.954	2200	5.625	1000	4.717
64.0	8.233	2300	5.709	1050	4.771*
68.4	9.832	2400	5.792	1100	4.822*
73.2	1.175 x 10 ⁻²	2500	5.876	1150	4.870
78.0	1.399	2600	5.959	1200	4.916
81.3	1.578	2700	6.043*	CURVE 5	
81.5	1.583	2800	6.126*	527.04	3.668 x 10 ⁻¹
85.7	1.778	2820	6.143	589.82	3.777
94.5	2.306	CURVE 3		693.71	3.954
103.4	2.966	363.15	2.48 x 10 ⁻¹	818.15	4.157
111.9	3.681	373.15	2.98 x 10 ⁻¹	1009.26	4.453
122.1	4.636	473.15	3.54	1112.04	4.604*
132.1	5.683	573.15	3.84	1202.59	4.732*
142.0	6.695	673.15	4.08	1358.70	4.943
152.2	7.846	773.15	4.26	1440.37	5.047
162.8	9.097	873.15	4.43	1555.93	5.189
172.5	1.026 x 10 ⁻¹	973.15	4.60	1653.71	5.303
182.0	1.1443	1073.15	4.76	1744.32	5.405
192.4	1.2730	CURVE 4		1812.04	5.478
202.3	1.3933	298.15	2.440 x 10 ⁻¹ *	1899.82	5.568
212.5	1.5172	300	2.457*	2005.37	5.672
222.3	1.6351	320	2.637	2138.71	5.794
232.6	1.7606	340	2.803*	2247.04	5.886*
242.4	1.8685	360	2.956*	2277.59	5.911
252.3	1.9772	380	3.097	CURVE 6	
262.2	2.0895	400	3.230	533.15	3.85 x 10 ⁻¹
272.4	2.1938	420	3.348	810.93	4.17*
282.2	2.2846	440	3.454	1088.71	4.70
288.4	2.3273*	460	3.551*	1366.48	5.10
292.4	2.3773	480	3.640	1644.26	5.50
CURVE 2		500	3.721	1922.04	5.70
1142	4.741 x 10 ⁻¹	550	3.899	2199.82	5.70
1200	4.789	600	4.046		
1300	4.873	650	4.171		
1400	4.957	700	4.278		
1500	5.040	750	4.372		
1600	5.124	800	4.455		
1700	5.207	850	4.529		
1800	5.291	900	4.597		
1900	5.374				
2000	5.458				

* Not shown on plot

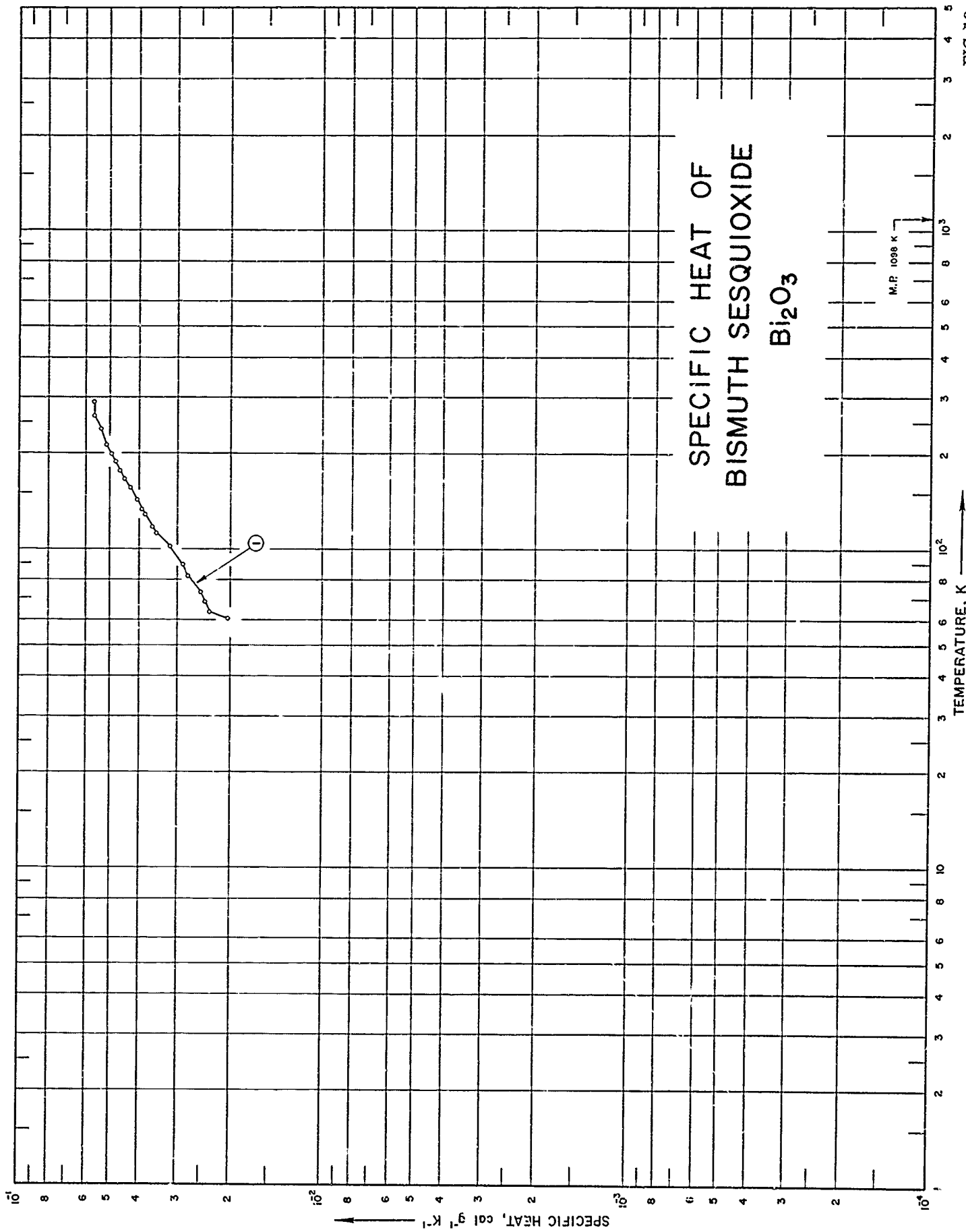

FIG. 13

SPECIFICATION TABLE NO. 13 SPECIFIC HEAT OF BISMUTH SESQUIOXIDE Bi_2O_3

[For Data Reported in Figure and Table No. 13]

Curve No.	Ref. No.	Year	Temp. Range, K	Reported Error, %	Name and Specimen Designation	Composition (weight percent), Specifications and Remarks
1	49	1930	60-289			99.6 Bi_2O_3 ; density 9.33 g cm^{-3} at 23.3 C .

DATA TABLE NO. 13 SPECIFIC HEAT OF BISMUTH SESQUIOXIDE Bi_2O_3 [Temperature, T, K; Specific Heat, C_p , Cal $\text{g}^{-1} \text{K}^{-1}$]

T	C_p
<u>CURVE 1</u>	
60.6	2.039×10^{-2}
63.7	2.337
68.7	2.412
73.6	2.498
82.6	2.758
89.3	2.858
101.4	3.159
113.0	3.500
118.6	3.618
129.2	3.820
143.1	4.062
155.7	4.283
166.4	4.474
175.8	4.612
188.5	4.796
198.2	4.925
134.7	3.914
213.3	5.122
238.4	5.339
289.3	5.633
262.1	5.616
271.4	5.642*
279.7	5.695*

*Not shown on plot

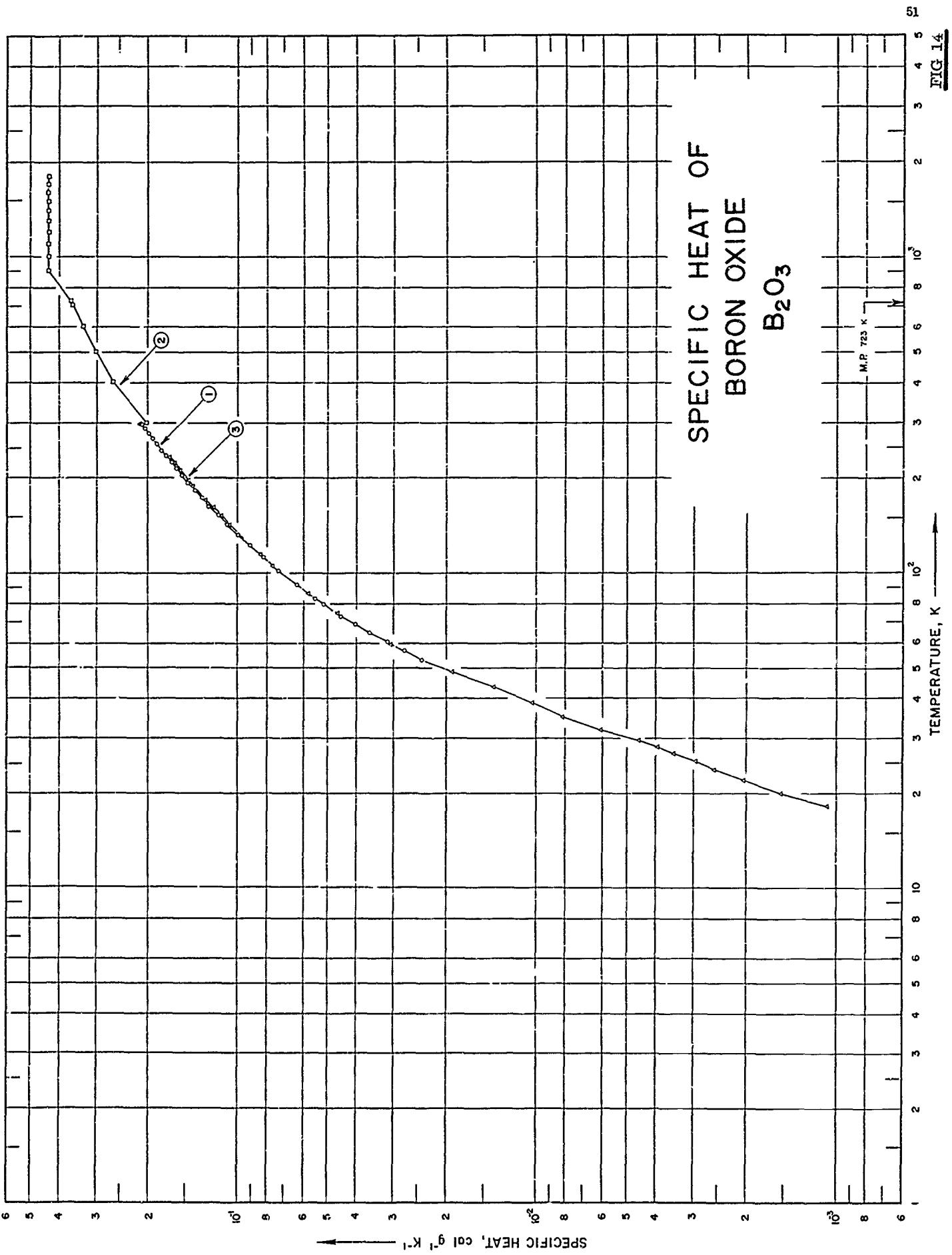

FIG 14

SPECIFICATION TABLE NO. 14 SPECIFIC HEAT OF BORON OXIDE B_2O_3

[For Data Reported in Figure and Table No. 14 J

Curve No.	Ref. No.	Year	Temp. Range, K	Reported Error, %	Name and Specimen Designation	Composition (weight percent), Specifications and Remarks
1	50	1941	52-295			99.7 B_2O_3 , 0.10 H_2O , 0.10 accounted for in impurities of original boric acid, 0.10 unaccounted; prepared from boric acid by heating 1 week at 120 C after which temperature raised 10 C daily up to 200 C for one day, resulting crystals heated 400 C for two days.
2	51	1941	289-1800			Two samples of boron sesquioxide glass; 99.30 - 99.79 B_2O_3 , 0.06 - .055 A_2O .
3	52	1950	18-295			B_2O_3 ; moisture free to about 0.1%; prepared by heating for one week boric acid (0.05 impurity) at 120 - 130 C after which temperature increased 10 C per day until it remained at 200 C for one day; resulting mixture crystallized at 200 C over three day period; temperature raised to 400 C for two days under vacuum; resulting material crushed, screened and heated three more days at 400 C under vacuum.

DATA TABLE NO. 14 SPECIFIC HEAT OF BORON OXIDE B₂O₃

[Temperature, T, K; Specific Heat, C_p, Cal g⁻¹ K⁻¹]

T	C _p	T	C _p	T	C _p
<u>CURVE 1</u>					
52.9	2.434 x 10 ⁻²	1400	4.372 x 10 ⁻¹	247.38	1.829 x 10 ⁻¹
56.3	2.760	1500	4.372	257.32	1.882
60.1	3.165	1600	4.372	273.10	1.982
64.3	3.620	1700	4.372	284.00	2.069
68.4	4.057	1800	4.372	296.60	2.151
72.7	4.512	<u>CURVE 3</u>			
79.4	5.188	18.08	1.073 x 10 ⁻³		
82.7	5.511	19.94	1.535		
91.5	6.340	21.58	2.035		
101.8	7.345	23.64	2.549		
112.0	8.258	25.19	2.921		
122.2	9.137	26.55	3.489		
132.6	1.002 x 10 ⁻¹	27.95	3.937		
143.2	1.092	29.30	4.585		
153.2	1.167	31.57	6.081		
163.7	1.257	34.81	8.171		
174.0	1.332	38.65	1.085 x 10 ⁻²		
183.8	1.404	43.33	1.390		
194.5	1.482	48.48	1.503		
204.3	1.551	53.53	2.488*		
214.5	1.617	59.10	3.069		
224.3	1.689	63.20	3.488*		
234.9	1.759	69.72	4.056*		
244.7	1.818	74.23	4.632		
255.1	1.887	79.58	5.095*		
265.6	1.950	85.90	5.800		
275.7	2.005	89.71	6.200		
285.6	2.066	104.82	7.634		
295.1	2.114	114.39	8.420		
<u>CURVE 2</u>					
298.15	2.046 x 10 ⁻¹	123.32	9.182		
300	2.060*	132.19	9.917		
400	2.646	141.77	1.071 x 10 ⁻¹		
500	3.032	150.98	1.147		
600	3.341	160.31	1.216		
700	3.612	159.98	1.290		
(s) 723	3.671	187.01	1.416		
(l) 900	4.372	195.35	1.475		
1000	4.372	204.19	1.539		
1100	4.372	210.32	1.579		
1200	4.372	220.39	1.644		
1300	4.372	230.55	1.707		
		235.87	1.743		

* Not shown on plot

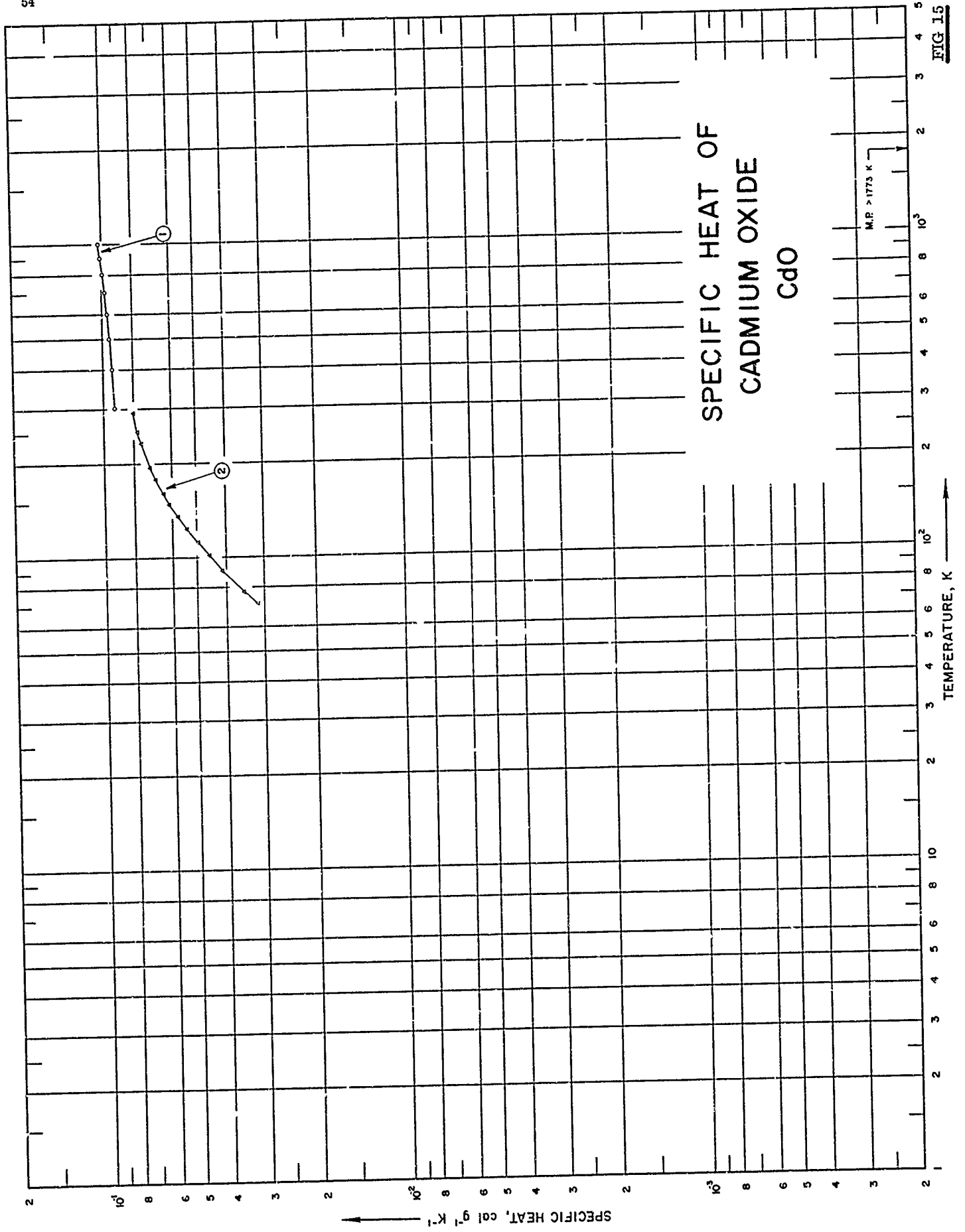

FIG. 15

SPECIFICATION TABLE NO. 15 SPECIFIC HEAT OF CADMIUM OXIDE CdO

[For Data Reported in Figure and Table No. 15]

Curve No.	Ref. No.	Year	Temp. Range, K	Reported Error, %	Name and Specimen Designation	Composition (weight percent), Specifications and Remarks
1	54	1965	300-1000	1.3		99.9525 CdO; supplied by J. T. Baker Chemical Co..
2	152	1928	71-253			Crystalline; prepared by heating pure cadmium oxide in an open platinum dish at 1100 C for 3 days.

DATA TABLE NO. 15 SPECIFIC HEAT OF CADMIUM OXIDE CdO
 [Temperature, T, K; Specific Heat C_p , Cal g⁻¹ K⁻¹]

T	C_p
<u>CURVE 1</u>	
300	9.174×10^{-2}
400	9.330
500	9.486
600	9.642
700	9.798
800	9.953
900	1.011×10^{-1}
1000	1.026
<u>CURVE 2</u>	
71.3	3.176×10^{-2}
77.9	3.501
90.5	4.117
101.1	4.551
112.2	4.986
124.2	5.407
136.1	5.810
148.0	6.188
160.9	6.471
288.0	8.061*
289.2	8.061*
290.4	8.022
151.9	6.266*
177.1	6.833
194.9	7.138
232.5	7.694
253.5	7.835

* Not shown on plot

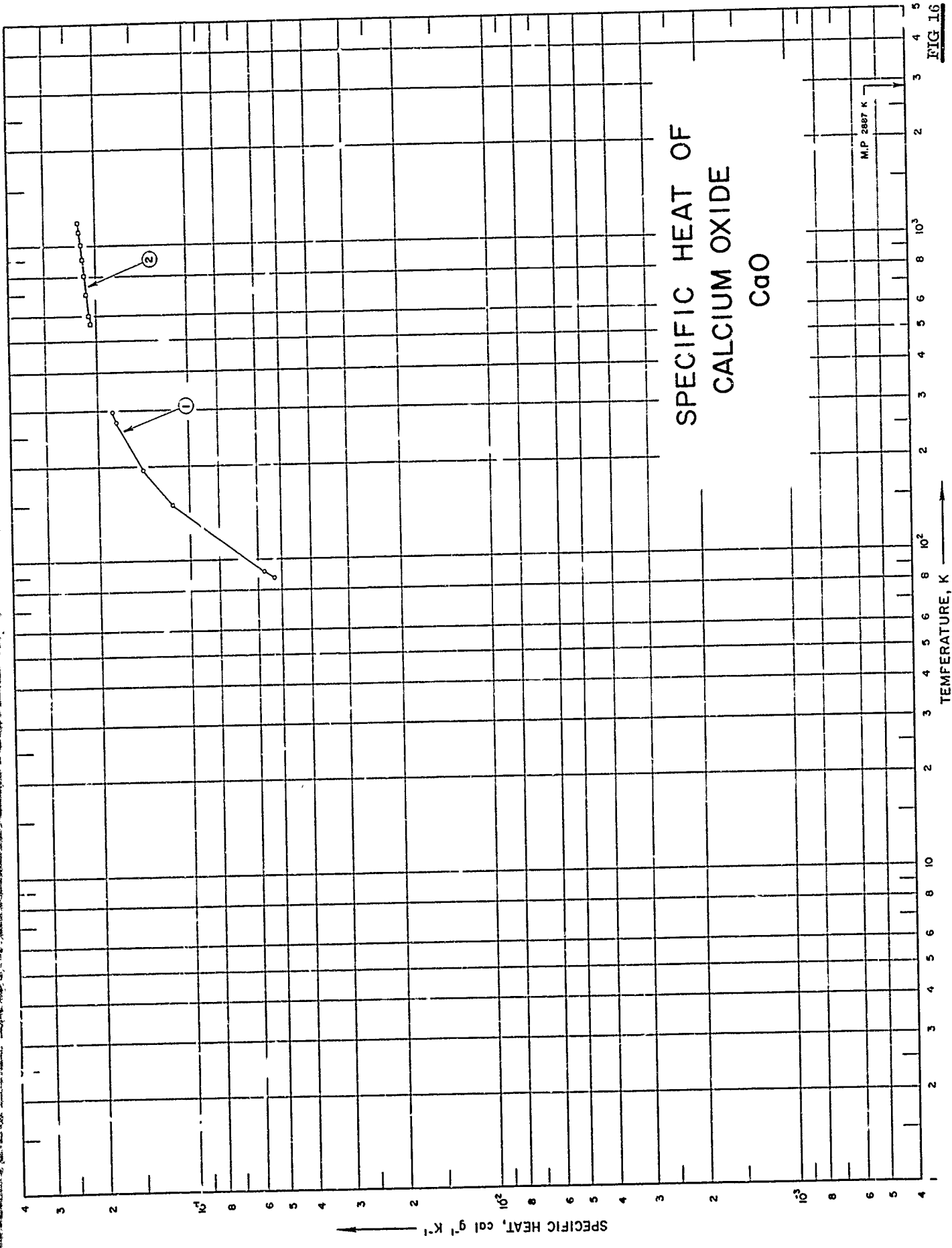

SPECIFIC HEAT OF
CALCIUM OXIDE
CaO

FIG. 16

SPECIFICATION TABLE NO. 16 SPECIFIC HEAT OF CALCIUM OXIDE CaO

[For Data Reported in Figure and Table No. 16]

Curve No.	Ref. No.	Year	Temp. Range, K	Reported Error, %	Name and Specimen Designation	Composition (weight percent), Specifications and Remarks
1	53	1926	87-293	1.0		98.8 CaO, 0.4 H ₂ O.
2	42	1951	563-1176			Material obtained by calcinating CaO ₃ at 800 C in vacuum.

DATA TABLE NO. 16 SPECIFIC HEAT OF CALCIUM OXIDE CaO
 [Temperature, T, K; Specific Heat, Cp, Cal g⁻¹ K⁻¹]

T	Cp
<u>CURVE 1</u>	
87.2	5.35 x 10 ⁻²
87.7	5.36*
91.1	5.79
92.2	5.91*
150.3	1.156 x 10 ⁻¹
194.0	1.446
197.1	1.474*
275.4	1.762
277.8	1.772*
282.1	1.794*
292.7	1.808
<u>CURVE 2</u>	
563	2.130 x 10 ⁻¹
600	2.148
700	2.189
800	2.223
900	2.252
1000	2.278
1100	2.302
1176	2.320

* Not shown on plot

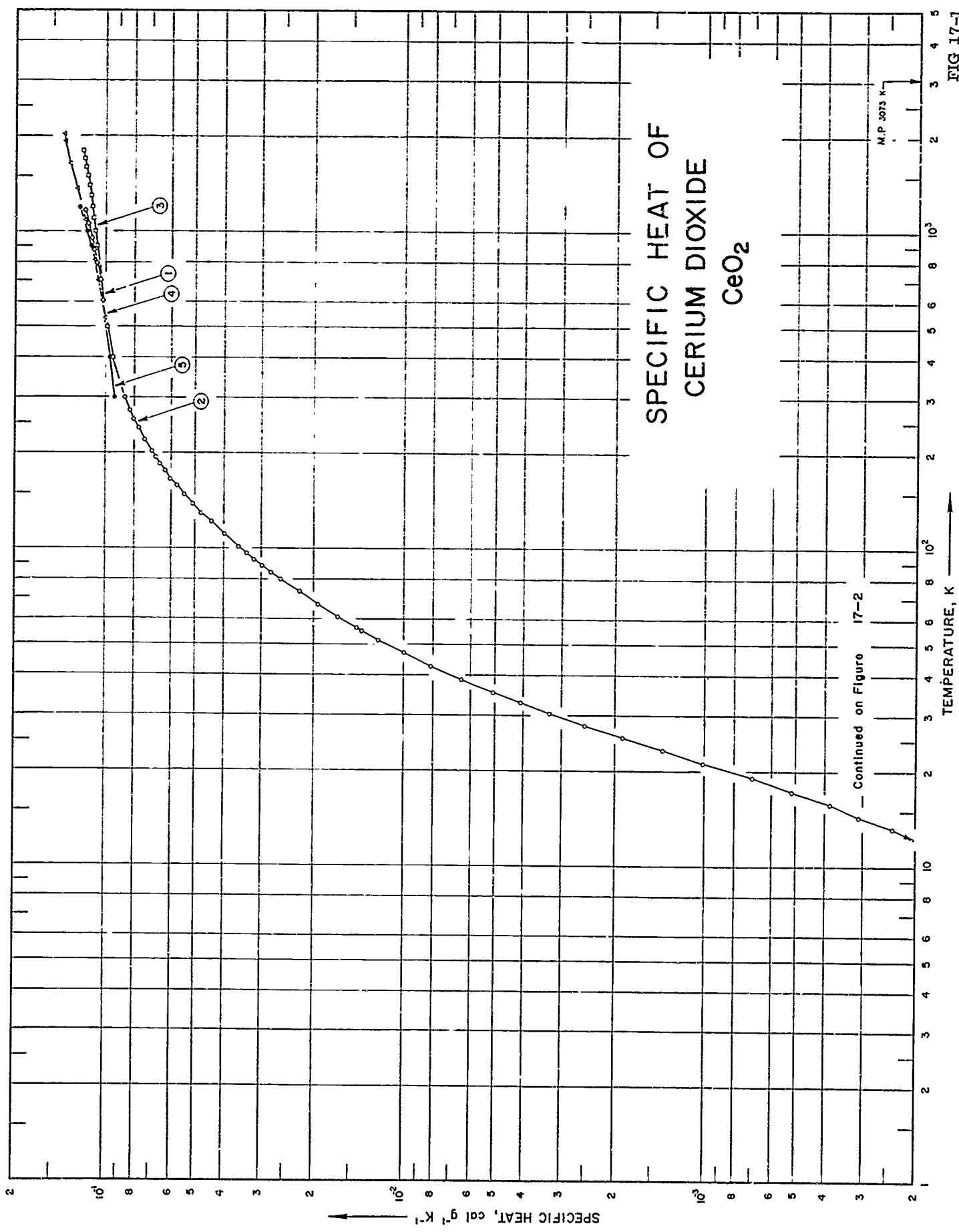
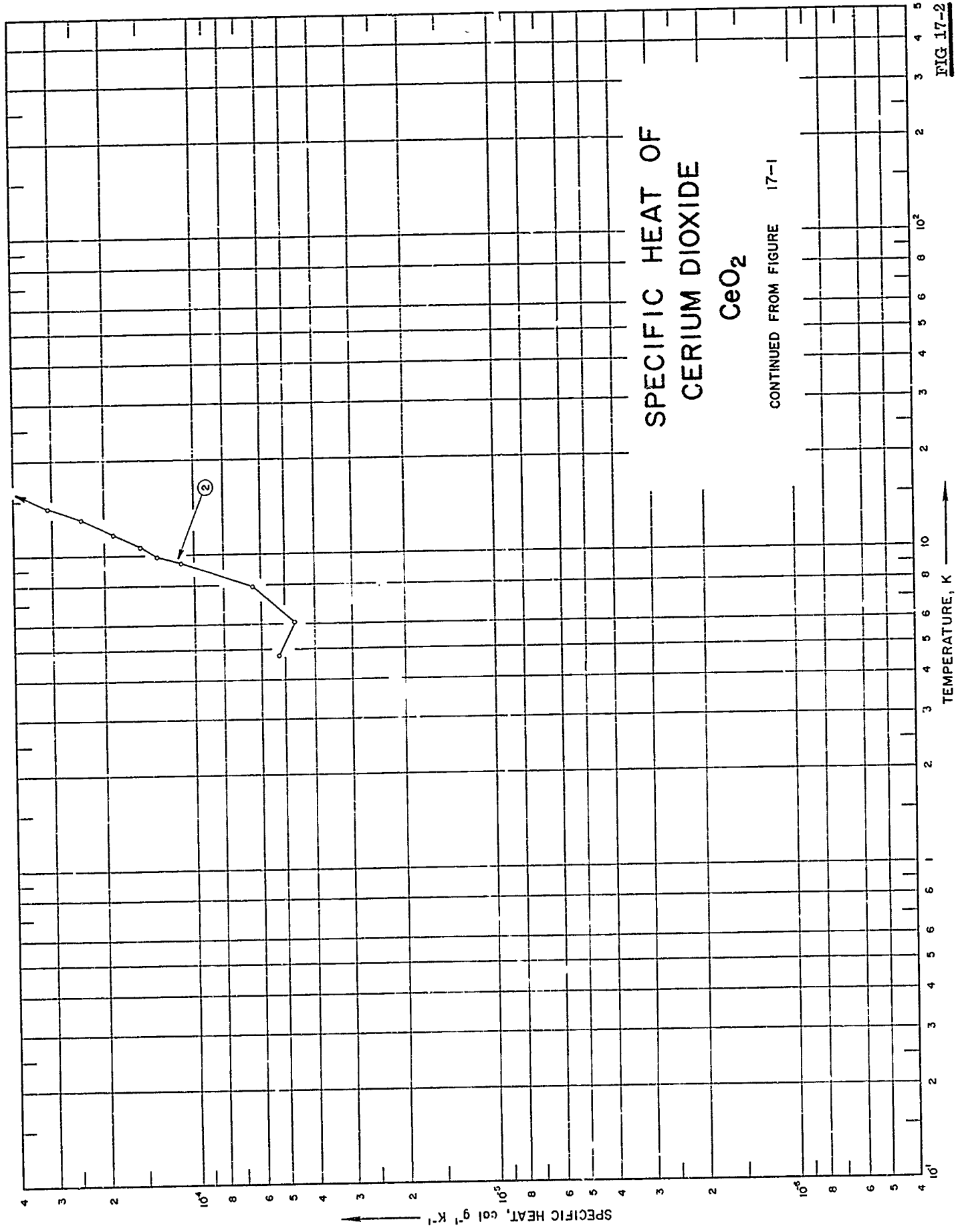

FIG 17-1



SPECIFICATION TABLE NO. 17 SPECIFIC HEAT OF CERIUM DIOXIDE CeO_2

[For Data Reported in Figure and Table No. 17]

Curve No.	Ref. No.	Year	Temp. Range, K	Reported Error, %	Name and Specimen Designation	Composition (weight percent), Specifications and Remarks
1	55	1960	608-1172	0.2		99.9 CeO_2 .
2	285	1961	5-302	0.1-10		~99.98 CeO_2 ; prepared by precipitating cerium hydroxide using gaseous ammonia and igniting in air to dioxide at 1000 C for 72 hrs.
3	57	1961	298-1800	0.2		99.9 CeO_2 ; supplied by Lindsay Chemical Co., heated at 1050 C for 1 hr.
4	48	1962	533-2044	≤ 5		Composition before exposure: 82.2 Ce, 0.2 Zr, 0.1 Ca; after exposure: 81.5 Ce, 0.10 C; supplied by Zirconium Corp. of America; crushed in hardened steel mortar to pass 100-mesh screen, pressed and sintered; density at 25 C before exposure: apparent density (ASTM method B311-58) 412 lb ft ⁻³ , true density (by immersion in xylene) 429 lb ft ⁻³ , after exposure: apparent density 410 lb ft ⁻³ , true density 422 lb ft ⁻³ .
5	54	1965	300-1200	0.5		Spectroscopically pure; supplied by Johnson, Mathey and Co. Ltd., London.

DATA TABLE NO. 17 SPECIFIC HEAT OF CERIUM DIOXIDE CeO_2
 [Temperature, T, K; Specific Heat, C_p , Cal $\text{g}^{-1}\text{K}^{-1}$]

T	C_p	T	C_p	T	C_p
<u>CURVE 1</u>					
608.1	1.020×10^{-1}				
702.3	1.046				
797.3	1.073				
874.1	1.095				
951.9	1.117				
1066.2	1.150				
1171.7	1.180				
<u>CURVE 2</u>					
Series 1					
4.81	5.228×10^{-5}				
6.14	4.647				
7.97	6.391				
9.40	1.104×10^{-4}				
9.94	1.336				
10.70	1.511				
11.74	1.859				
13.15	2.382				
14.38	3.079				
15.66	3.835				
17.16	5.113				
19.00	6.914				
21.10	1.011×10^{-3}				
23.26	1.383				
25.49	1.877				
27.84	2.492				
30.37	3.259				
32.82	4.084				
35.37	5.026				
38.85	6.426				
42.85	8.105				
47.02	9.976				
51.65	1.210×10^{-2}				
56.66	1.444				
55.32	1.380				
60.96	1.655				
66.86	1.938				
73.12	2.235				
80.15	2.573				
88.36	2.963				
96.76	3.345				
121.27	4.398				
<u>CURVE 2 (cont.)</u>					
Series 2					
84.27	2.770×10^{-2}				
92.55	3.155				
101.64	3.561				
110.92	3.963				
120.31	4.356*				
129.59	4.726				
138.75	5.073				
147.95	5.404				
157.15	5.717				
166.34	6.007				
175.63	6.281				
185.01	6.536				
194.26	6.774				
203.32	6.989				
212.20	7.187*				
220.94	7.367				
229.62	7.535*				
239.51	7.704				
247.55	7.855*				
256.58	8.000*				
265.54	8.134*				
274.58	8.267*				
283.63	8.384*				
292.64	8.500				
301.69	8.599				
<u>CURVE 3</u>					
298.15	8.549×10^{-2} *				
300	8.572*				
400	9.407				
500	9.856				
600	1.015×10^{-1} *				
700	1.036*				
800	1.057*				
900	1.073				
1000	1.089				
1100	1.103				
1200	1.117				
1300	1.130				
1400	1.143				
1500	1.155				
<u>CURVE 4</u>					
533.15	1.00×10^{-1}				
810.93	1.09				
1088.71	1.17				
1366.48	1.25				
1644.26	1.32				
1922.04	1.37				
2044.26	1.38				
<u>CURVE 5</u>					
300	9.255×10^{-2}				
400	9.581				
500	9.912*				
600	1.024×10^{-1} *				
700	1.056*				
800	1.089*				
900	1.122				
1000	1.154*				
1100	1.187*				
1200	1.220				

* Not shown on plot

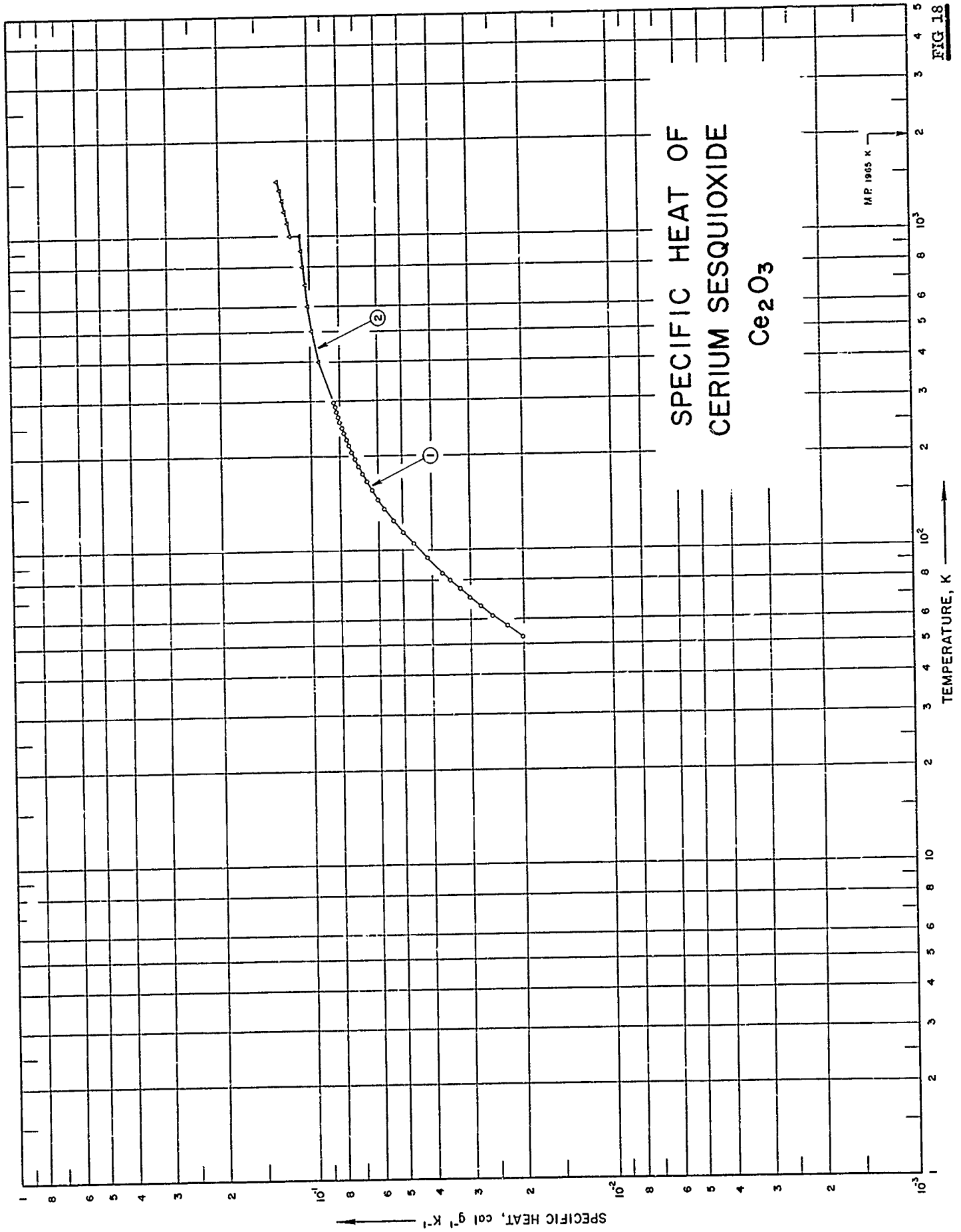

FIG 18

SPECIFICATION TABLE NO. 18 SPECIFIC HEAT OF CERUM SESQUIOXIDE Ce_2O_3

[For Data Reported in Figure and Table No. 18]

Curve No.	Ref. No.	Year	Temp. Range, K	Reported Error, %	Name and Specimen Designation	Composition (weight percent), Specifications and Remarks
1	58	1963	50-298	0.10		$Ce_2O_{3.33}$: 0.02 Al_2O_3 , < 0.002 C; measured under nitrogen atmosphere.
2	59	1963	298-1500			$Ce_2O_{3.33}$: 99.9 CeO_2 , 0.02 Al_2O_3 , 0.001 C.

DATA TABLE NO. 18 SPECIFIC HEAT OF CERIUM SESQUOXIDE Ce_2O_3 [Temperature, T, K; Specific Heat, C_p , Cal $\text{g}^{-1} \text{K}^{-1}$]

T	C_p		T	C_p
	CURVE 1	CURVE 2 (cont.)		
52.96	2.007×10^{-2}	(β) 1300	1.2249 $\times 10^{-1}$	
57.27	2.250	(β) 1400	1.2489	
61.73	2.522	(β) 1500	1.2729	
66.17	2.761			
70.66	2.995			
75.18	3.235			
80.02	3.482			
84.61	3.689			
94.47	4.140			
105.03	4.594			
114.78	4.981			
124.76	5.350			
135.97	5.728			
145.67	6.005			
155.74	6.276			
165.85	6.520			
176.10	6.763			
186.13	6.955			
196.02	7.136			
206.40	7.312			
216.39	7.461			
226.39	7.604			
236.19	7.741			
245.62	7.866			
256.84	7.990			
266.35	8.083			
276.97	8.186			
286.81	8.274			
296.61	8.351			
CURVE 2				
(α) 298.15	8.3611×10^{-2} *			
300	8.3874*			
400	9.3399			
500	9.8246			
600	1.0125 $\times 10^{-1}$			
700	1.0339			
800	1.0506			
900	1.0647			
(α)1000	1.0770			
(β)1000	1.1515			
1100	1.1762			
1200	1.2006			

* Not shown on plot

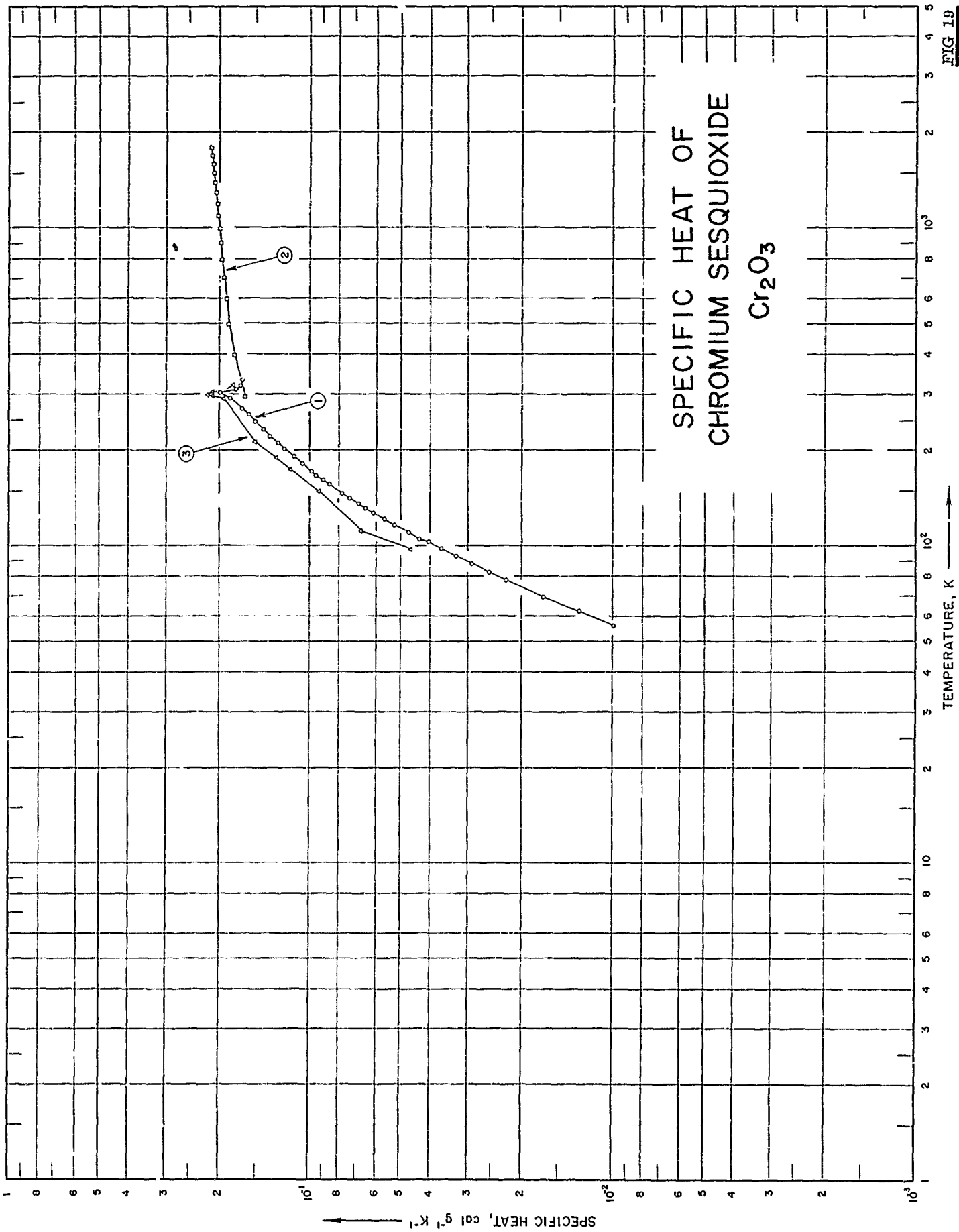

FIG 19

SPECIFICATION TABLE NO. 19 SPECIFIC HEAT OF CHROMIUM SESQUIOXIDE Cr_2O_3

[For Data Reported in Figure and Table No. 19]

Curve No.	Ref. No.	Year	Temp. Range, K	Reported Error, %	Name and Specimen Designation	Composition (weight percent), Specifications and Remarks
1	60	1937	56-335			100 Cr_2O_3 .
2	61	1944	298-1800			Sample prepared by firing ammonium chromate in air at 1000 C.
3	62	1952	98-322			

DATA TABLE NO. 19 SPECIFIC HEAT OF CHROMIUM SESQUIOXIDE Cr_2O_3
 [Temperature, T, K; Specific Heat, C_p , Cal $\text{g}^{-1} \text{K}^{-1}$]

T	C_p	T	C_p	T	C_p
56.3	9.893×10^{-3}	294.9	1.8524×10^{-1} *	98	4.605×10^{-2}
62.5	1.288×10^{-2}	296.2	1.8708*	112	6.742
69.4	1.695	299.6	1.8998*	149	9.308
78.5	2.248	299.7	1.9024*	174	1.1577×10^{-1}
83.0	2.543	301.5	1.9320*	190	1.2959
88.1	2.901	302.4	1.9432*	214	1.5130
93.0	3.264	302.6	1.9445*	291	1.9340
98.1	3.659	303.7	1.9622*	294	1.9734*
98.6	3.703*	304.4	1.9728*	298	2.1050
102.9	4.058	305.5	1.9787	300	2.1938
105.9	4.333	306.6	1.9491*	307	2.1017
107.4	4.426*	306.7	1.9280*	310	1.8748*
111.1	4.691	308.3	1.9294*	320	1.8156*
117.2	5.230	309.7	1.8090*	330	1.8156*
122.2	5.674	311.1	1.7912*	329	1.7892*
127.4	6.126	311.6	1.7623*	322	1.7991
132.1	6.514	313.9	1.7550		
136.4	6.874	316.8	1.7096*		
141.7	7.341	320.2	1.6899		
147.0	7.782	324.8	1.6754*		
157.4	8.598	329.9	1.6761*		
162.2	9.005	335.6	1.6669		
168.5	9.505				
172.7	9.821				
176.6	1.0137×10^{-1} *				
182.6	1.0584				
187.4	1.0933*				
192.1	1.1314				
199.6	1.1827*				
203.6	1.2123				
207.9	1.2459*				
212.6	1.2781				
217.9	1.3117*				
223.7	1.3557				
229.0	1.3906*				
234.9	1.4307				
239.7	1.4570*				
247.6	1.5130				
260.4	1.5919				
273.3	1.6800				
276.7	1.7037*				
281.8	1.7432*				
293.4	1.8438				

T	C_p	T	C_p
298.15	1.643×10^{-1}		
300	1.647*		
400	1.781		
500	1.851		
600	1.896		
700	1.928		
800	1.954		
900	1.977		
1000	1.987		
1100	2.016		
1200	2.033		
1300	2.050		
1400	2.067		
1500	2.083		
1600	2.099		
1700	2.115		
1800	2.130		

T	C_p	T	C_p
294.9	1.8524×10^{-1} *		
296.2	1.8708*		
299.6	1.8998*		
299.7	1.9024*		
301.5	1.9320*		
302.4	1.9432*		
302.6	1.9445*		
303.7	1.9622*		
304.4	1.9728*		
305.5	1.9787		
306.6	1.9491*		
306.7	1.9280*		
308.3	1.9294*		
309.7	1.8090*		
311.1	1.7912*		
311.6	1.7623*		
313.9	1.7550		
316.8	1.7096*		
320.2	1.6899		
324.8	1.6754*		
329.9	1.6761*		
335.6	1.6669		

* Not shown on plot

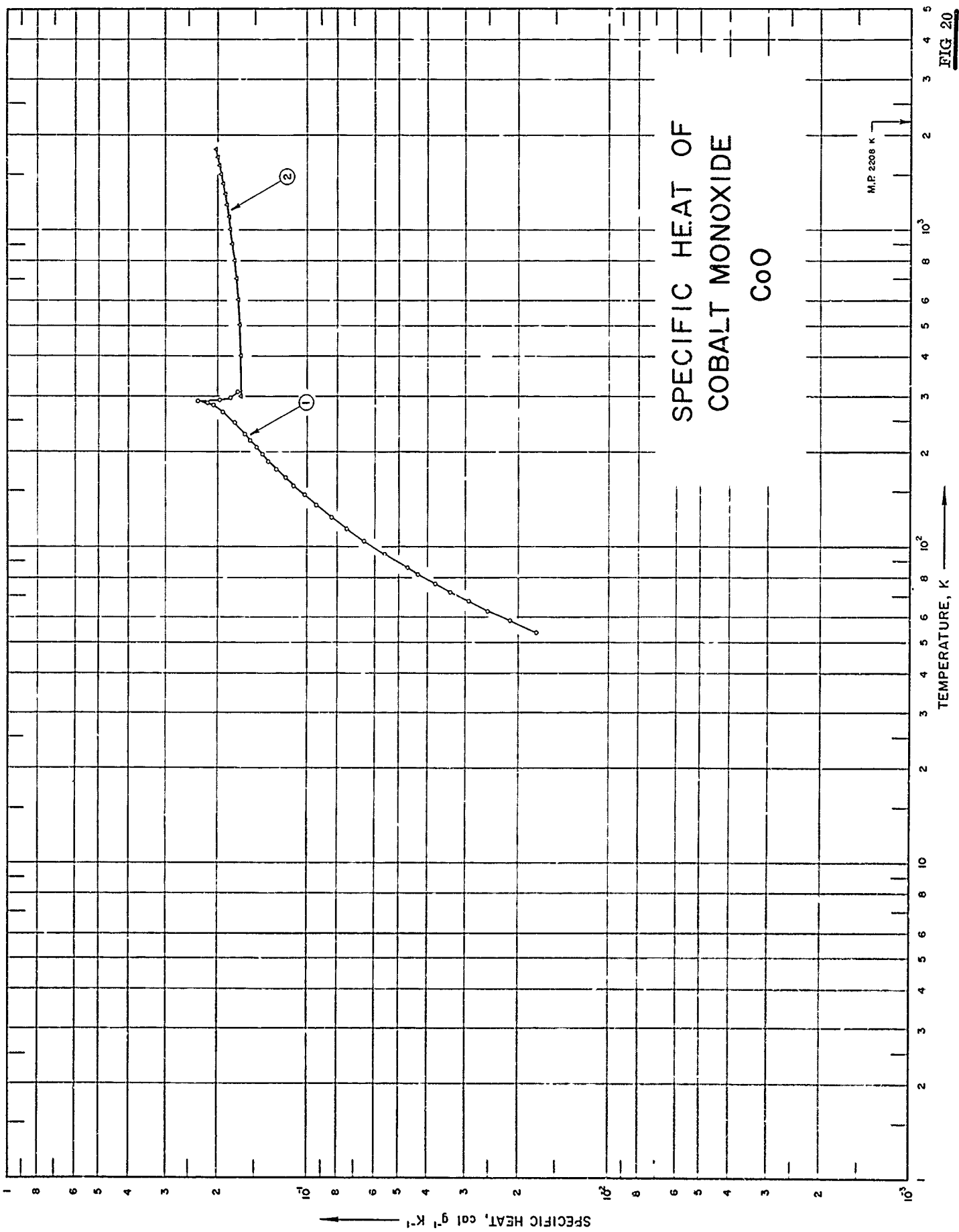

FIG 20

SPECIFICATION TABLE NO. 23 SPECIFIC HEAT OF COBALT MONOXIDE CoO

[For Data Reported in Figure and Table No. 20]

Curve No.	Ref. No.	Year	Temp. Range, K	Reported Error, %	Name and Specimen Designation	Composition (weight percent), Specifications and Remarks
1	63	1957	53-308			CoO, 78.61 Co; prepared from recrystallized reagent grade cobaltous sulfate heptahydrate.
2	64	1958	298-1800	0.5		78.61 Co, 21.36 O ₂ , 0.02 SiO ₂ , 0.01 S; reheated 72 hrs in air at 1180 - 1230 C, then 28 hrs in helium at 1150 - 1160 C.

DATA TABLE NO. 20 SPECIFIC HEAT OF COBALT MONOXIDE CoO

[Temperature, T, K; Specific Heat, C_p , Cal g^{-1} K $^{-1}$]

CURVE 1		CURVE 2	
T	$C_p \times 10^{-2}$	T	$C_p \times 10^{-1}$
53.61	1.747	298.15	1.681
58.27	2.133	300	1.682
62.80	2.530	400	1.682
67.20	2.929	500	1.697
71.72	3.352	600	1.718
76.31	3.783	700	1.741
81.76	4.308	800	1.766
85.71	4.687	900	1.751
94.37	5.524	1000	1.817
104.79	6.536	1100	1.844
114.22	7.426	1200	1.870
124.28	8.367	1300	1.897
135.71	9.390	1400	1.924
145.57	1.027 $\times 10^{-1}$	1500	1.951
155.66	1.113	1600	1.978
165.67	1.193	1700	2.005
175.82	1.272	1800	2.032
185.97	1.351		
195.82	1.419		
206.10	1.490		
215.94	1.558		
225.96	1.627		
235.85	1.694*		
245.65	1.761		
256.13	1.841*		
266.10	1.926		
276.03	2.028*		
279.74	2.083		
282.15	2.121*		
284.06	2.173		
285.48	2.228*		
286.36	2.252*		
286.48	2.287*		
287.37	2.345		
288.27	2.255*		
289.27	2.147*		
290.33	1.969		
291.44	1.889*		
292.59	1.841*		
294.25	1.803		
296.82	1.775*		
297.34	1.771*		
299.87	1.750*		
303.40	1.734*		
307.61	1.722		

*Not shown on plot

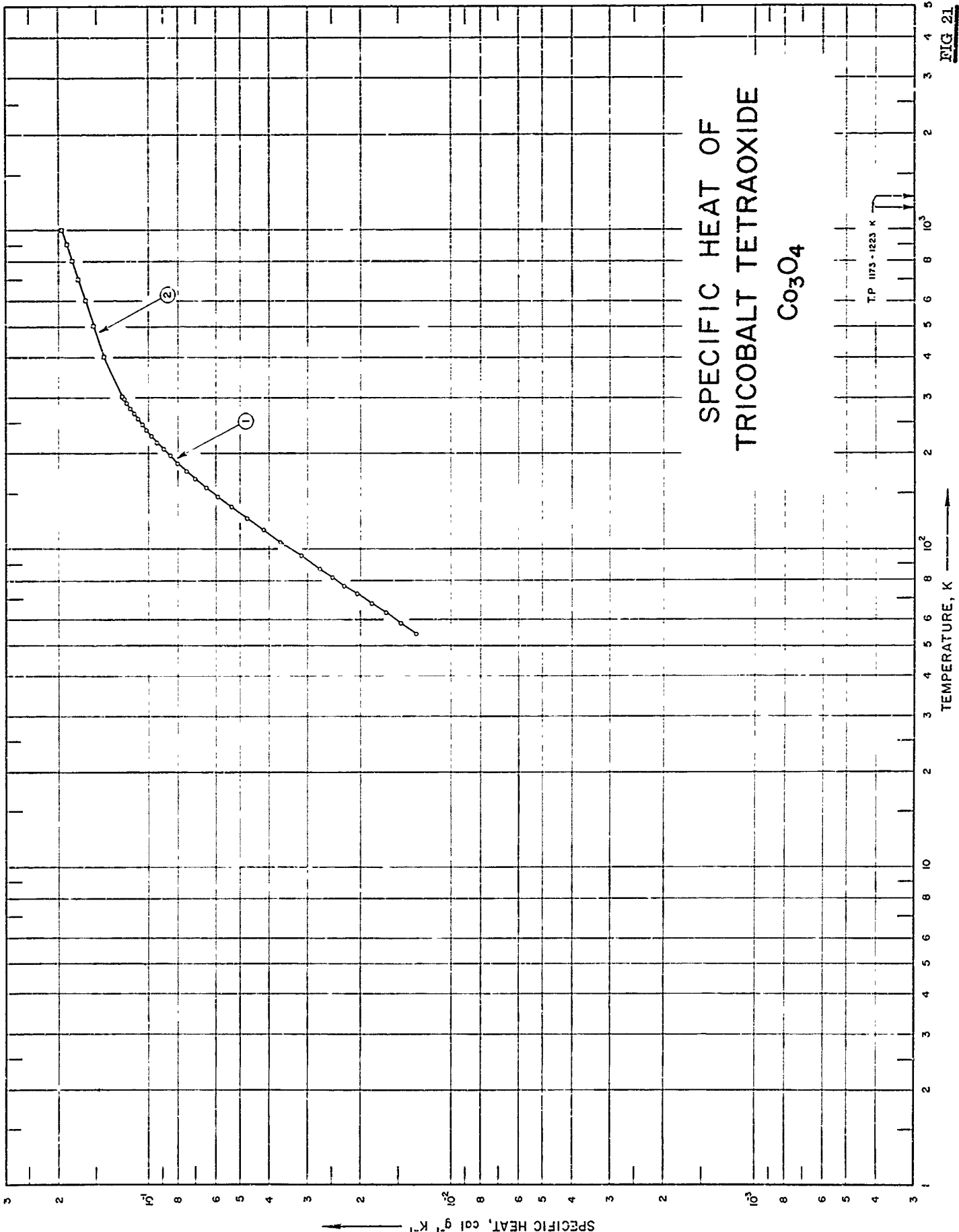

FIG 21

SPECIFICATION TABLE NO. 21 SPECIFIC HEAT OF TRICOBALT TETRAOXIDE Co_3O_4

[For Data Reported in Figure and Table No. 21]

Curve No.	Ref. No.	Year	Temp. Range, K	Reported Error, %	Name and Specimen Designation	Composition (weight percent), Specifications and Remarks
1	63	1957	54-296			
2	64	1958	298-1000	0.5		Cobalt spinel Co_3O_4 ; prepared from recrystallized reagent grade cobalt sulfate heptahydrate. 73.40 Co; prepared from reagent grade cobalt sulfate heptahydrate by heating in air 15 days at 850 C and 16 hrs at 900 C; quenched to room temperature.

DATA TABLE NO. 21 SPECIFIC HEAT OF TRICOBALT TETRAOXIDE Co_3O_4 [Temperature, T, K; Specific Heat, C_p , Cal $\text{g}^{-1} \text{K}^{-1}$]

T	C_p
<u>CURVE 1</u>	
54.02	1.309×10^{-2}
58.55	1.472
63.05	1.641
67.68	1.843
72.32	2.050
76.78	2.261
81.40	2.473
86.53	2.722
94.92	3.143
104.98	3.675
114.67	4.190
124.81	4.755
136.03	5.369
148.76	5.921
155.91	6.482
165.95	7.014
176.02	7.524
186.06	8.039
196.02	8.500
206.38	8.990
216.33	9.418
226.40	9.833
236.23	1.022×10^{-1}
245.77	1.057
256.47	1.095
266.42	1.129
276.33	1.162
286.92	1.192
296.34	1.216
<u>CURVE 2</u>	
298.15	1.225×10^{-1} *
300	1.229
400	1.416
500	1.540
600	1.640
700	1.729
800	1.811
900	1.890
1000	1.966

* Not shown on plot

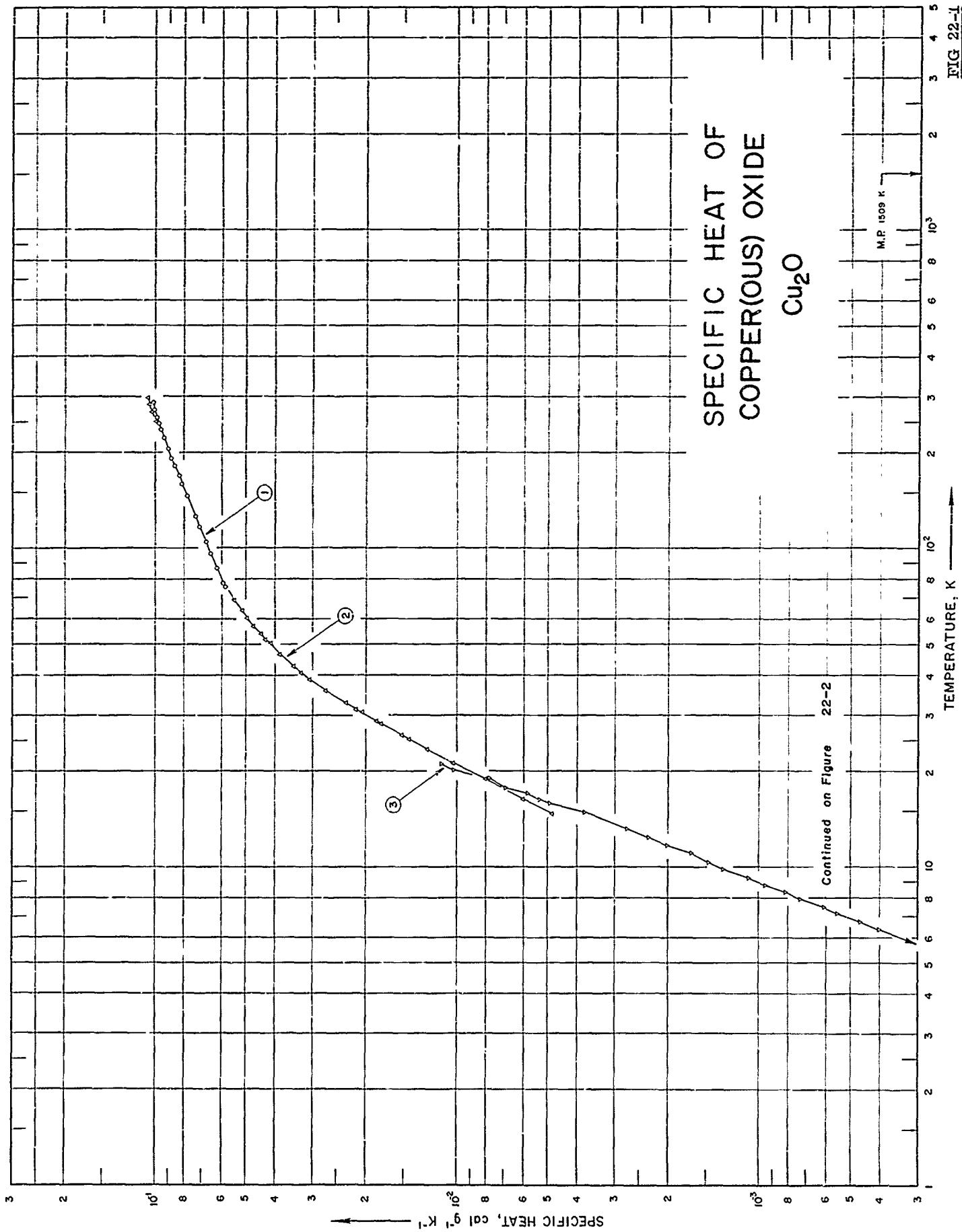
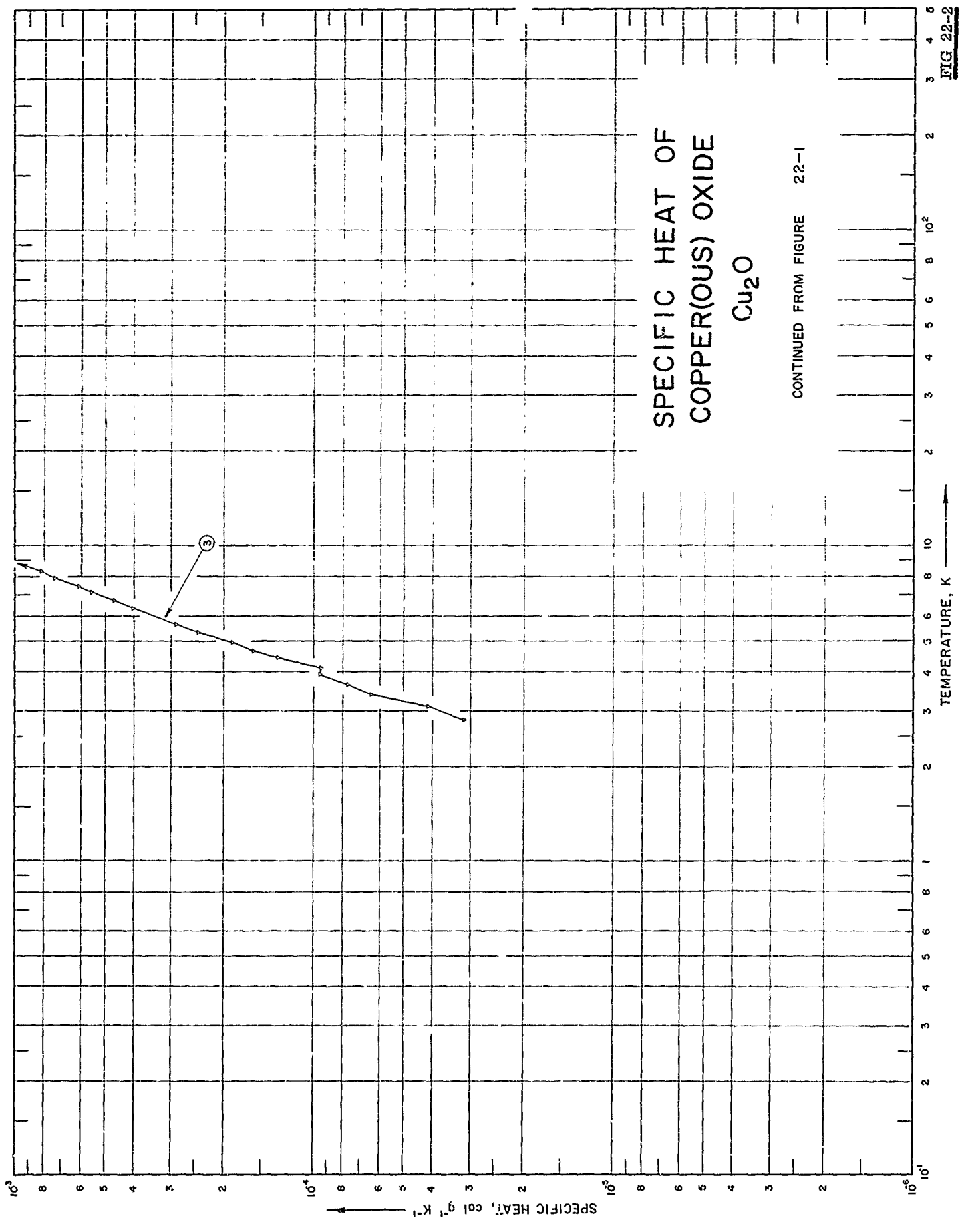

FIG 22-1

SPECIFIC HEAT OF COPPER(OUS) OXIDE Cu₂O

CONTINUED FROM FIGURE 22-1



SPECIFICATION TABLE NO. 22 SPECIFIC HEAT OF COPPER(OUS) OXIDE Cu_2O

[For Data Reported in Figure and Table No. 22]

Curve No.	Ref. No.	Year	Temp. Range, K	Reported Error, %	Name and Specimen Desig.	Composition (weight percent), Specifications and Remarks
1	65	1929	76-291			100 Cu_2O .
2	66	1951	14-300			99.8 Cu_2O ; prepared by precipitation of a warm Fehling solution with dextrose.
3	67	1962	2-19			99.4 Cu_2O ; finely divided red powder; prepared by reduction of warm Fehling solution with dextrose.

DATA TABLE NO. 22 SPECIFIC HEAT OF COPPER(OUS) OXIDE Cu_2O [Temperature, T, K; Specific Heat, C_p , Cal $\text{g}^{-1}\text{K}^{-1}$]

T	CURVE 1		CURVE 2 (cont.)		CURVE 3	
	T	C_p	T	C_p	T	C_p
75.9	5.847 x 10 ⁻²	47.04	3.914 x 10 ⁻²	2.794	3.151 x 10 ⁻⁵	
78.4	5.954	50.34	4.164	3.087	4.157	
87.0	6.245	51.84	4.322	3.375	6.441	
96.9	6.538	54.00	4.478	3.635	7.699	
105.3	6.794	57.01	4.716	3.937	9.522	
117.0	7.115	57.82	4.760*	4.107	9.445	
125.6	7.346	60.65	4.983*	4.406	1.328 x 10 ⁻⁴	
147.0	7.842	61.65	5.013*	4.662	1.596	
159.9	8.149	64.01	5.172	4.943	1.882	
170.0	8.310	69.44	5.470	5.313	2.449	
182.9	8.611	76.39	5.801*	5.671	2.898	
192.9	8.855	82.80	6.052*	6.384	4.015	
206.1	9.072	88.31	6.254*	6.760	4.649	
223.5	9.365	94.28	6.465*	7.138	5.518	
236.1	9.575	101.73	6.689*	7.496	6.125	
247.6	9.736	109.75	6.886*	7.910	7.328	
259.0	9.869	116.62	7.070*	8.335	8.195	
252.1	9.771*	124.00	7.259*	8.778	9.529	
273.5	1.004 x 10 ⁻¹	131.66	7.475*	9.269	1.086 x 10 ⁻³	
289.1	1.013	138.81	7.664*	9.811	1.313	
291.0	1.025*	145.42	7.832*	10.385	1.471	
		153.63	8.020*	11.019	1.688	
		160.73	8.195*	11.723	2.033	
		166.88	8.328*	12.462	2.326	
		174.06	8.488*	13.196	2.743	
14.72	4.869 x 10 ⁻³	181.20	8.642*	14.951	3.795	
16.47	6.036	187.89	8.782*	15.975	4.939	
18.99	8.076	194.87	8.928*	16.423	5.343	
21.31	1.028 x 10 ⁻²	203.79	9.075*	17.076	5.837	
23.49	1.253	212.62	9.264*	17.793	6.917	
25.22	1.448	229.00	9.410*	19.081	7.814	
26.00	1.530	236.16	9.578*	20.207	1.031 x 10 ⁻²	
28.22	1.793	243.54	9.690*	21.090	1.126	
28.75	1.846	252.12	9.802*			
30.53	2.068	259.67	9.934			
31.31	2.157	269.67	1.008 x 10 ⁻¹ *			
32.84	2.347	275.47	1.024			
35.70	2.710	283.67	1.033*			
38.89	3.087	291.67	1.044			
40.87	3.280	299.64	1.054*			
42.72	3.498		1.063			
43.39	3.543*					
46.69	3.861					

* Not shown on Plot

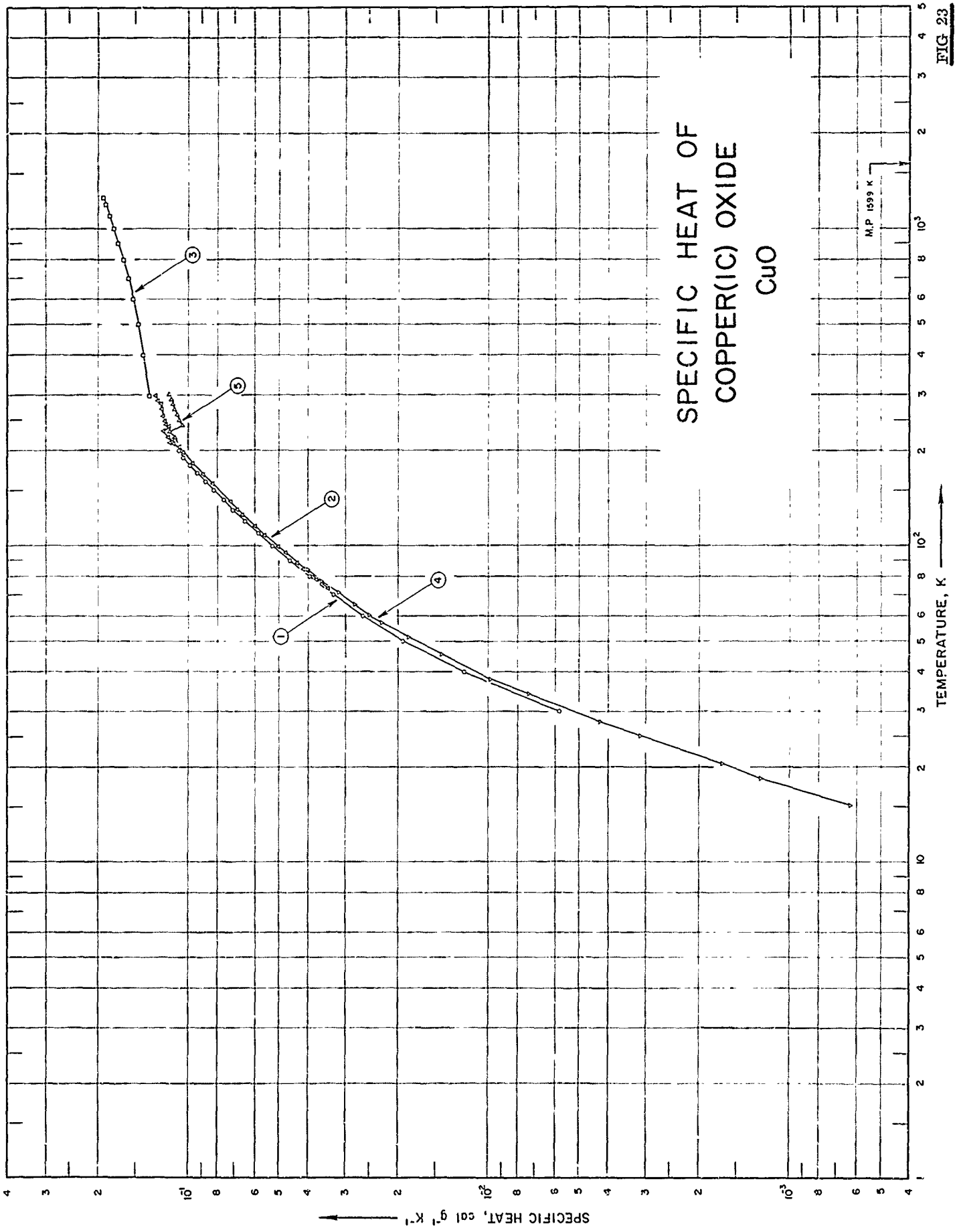

FIG. 23

SPECIFICATION TABLE NO. 23 SPECIFIC HEAT OF COPPER (IC) OXIDE CuO

[For Data Reported in Figure and Table No. 23]

Curve No.	Ref. No.	Year	Temp. Range, K	Reported Error, %	Name and Specimen Designation	Composition (weight percent), Specifications and Remarks
1	68	1928	30-200			Kahlbaum purity.
2	65	1929	71-302			99.4 CuO and 0.6 Cu ₂ O.
3	69	1933	298-1253			
4	70	1953	15-297			99.95 CuO; prepared by heating electrolytic copper (99.95 Cu) at 800 C in furnace for several days, repeatedly ground and oxidized.
5	71	1954	200-300			

DATA TABLE NO. 23 SPECIFIC HEAT OF COPPER (IC) OXIDE, CuO

[Temperature, T, K; Specific Heat, C_p , Cal g⁻¹K⁻¹]

T	C_p	T	C_p	T	C_p	T	C_p
<u>CURVE 1</u>							
30	5.8×10^{-3} *	212.3	1.149×10^{-1}	204.7	1.073×10^{-1}	231.68	1.158×10^{-1} *
40	1.2×10^{-2} *	214.4	1.128*	209.7	1.106*	240.26	1.160*
50	1.91*	219.9	1.166*	212.6	1.146*	248.52	1.173*
60	2.595*	221.3	1.159*	229.4	1.184*	187.12	9.780×10^{-2} *
70	3.256	224.4	1.179*	233.5	1.155*	196.44	1.025×10^{-1} *
80	3.917	237.9	1.158	238.2	1.155*	205.38	1.075
90	4.55	241.1	1.182	261.5	1.211*	214.58	1.068
100	5.20^*	248.7	1.197	265.7	1.200*	223.76	1.165
110	5.81*	258.3	1.204	271.4	1.218	232.53	1.159
120	6.41*	130.7	6.812 x 10 ⁻²	<u>CURVE 3</u>			
130	7.02*	133.7	6.954*	298.15	1.345×10^{-1}	249.12	1.173
140	7.57*	138.1	7.171	300	1.346*	15.14	6.286×10^{-4}
150	8.15	153.8	8.032*	300	1.346*	18.46	1.245×10^{-3}
160	8.70	157.2	8.252	400	1.407	20.50	1.660
170	9.25	163.0	8.552*	500	1.467	25.08	3.118
180	9.76	169.2	8.868	600	1.528	27.84	4.249
190	1.03×10^{-1}	183.5	9.601	700	1.588	34.01	7.317
200	1.07	211.1	1.121×10^{-1} *	800	1.648	37.96	9.819
<u>CURVE 2</u>							
71.3	3.244×10^{-2} *	217.0	1.126	900	1.709	45.48	1.432×10^{-2}
73.7	3.407*	230.5	1.203	1000	1.769	51.56	1.8254
75.8	3.550*	240.7	1.179*	1100	1.829	57.17	2.254
78.7	3.739	281.2	1.238	1200	1.890	60.30	2.482
81.8	3.926*	284.9	1.255*	1253	1.921	65.42	2.790
84.8	4.114	287.5	1.258	<u>CURVE 4</u>			
88.2	4.321	299.4	1.292*	218.60	1.144×10^{-1}	77.42	3.570
91.7	4.493*	301.6	1.291*	227.52	1.168*	84.02	3.987*
95.2	4.701	193.8	1.025*	235.81	1.161*	90.70	4.423*
99.5	4.994	197.6	1.036	243.96	1.166*	97.97	4.823*
108.5	5.552	201.1	1.045*	253.11	1.184*	105.40	5.307*
111.6	5.733*	204.5	1.069*	262.92	1.195*	112.95	5.752
115.2	5.940	208.1	1.105*	272.57	1.210*	121.73	6.250*
119.2	6.203*	211.6	1.134*	282.06	1.223*	130.62	6.745
122.2	6.428*	216.0	1.121*	289.47	1.255*	138.50	7.177*
125.2	6.556	219.2	1.135*	297.23	1.271*	146.57	7.661*
142.1	7.469*	228.8	1.184*	156.60	1.024×10^{-1}	155.84	8.186*
199.5	1.054×10^{-1} *	246.0	1.174*	174.47	1.130*	165.06	8.643*
203.5	1.076*	261.2	1.206*	183.73	9.626*	174.47	9.130*
210.1	1.116	289.1	1.263*	192.32	1.006×10^{-1} *	192.32	1.006 x 10 ⁻¹ *
		293.6	1.265	200.99	1.052*	200.99	1.052*
				209.82	1.109*	209.82	1.109*

Not shown on Plot

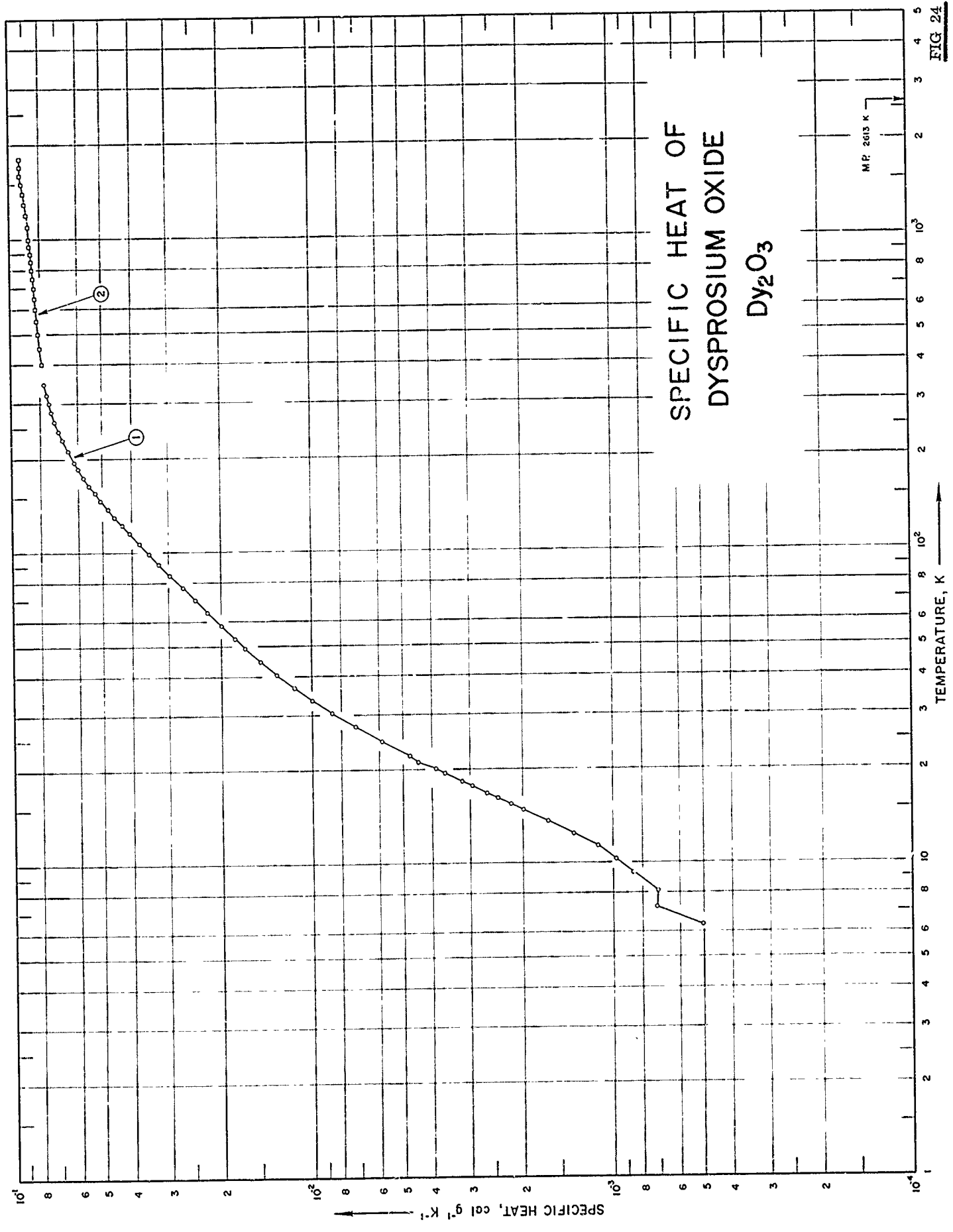

FIG 24

SPECIFICATION TABLE NO. 24 SPECIFIC HEAT OF DYSPROSIUM OXIDE Dy₂O₃

[For Data Reported in Figure and Table No. 24]

Curve No.	Ref. No.	Year	Temp. Range, K	Reported Error, %	Name and Specimen Designation	Composition (weight percent), Specifications and Remarks
1	72	1962	6-346	0.1		99.9 Dy ₂ O ₃ , 0.015 Y, 0.010 C, and 0.010 Si; powder specimen; supplied by Michigan Chemical Co; helium atmosphere.
2	59	1963	400-1800			99.9 Dy ₂ O ₃ ; dried at 1100 - 1200 C.

DATA TABLE NO. 24 SPECIFIC HEAT OF DYSPROSIUM OXIDE, Dy₂O₃
 [Temperature, T, K; Specific Heat, C_p, Cal g⁻¹K⁻¹]

T	C _p	T	C _p	T	C _p
CURVE 1		CURVE 1 (cont.)		CURVE 1 (cont.)	
Series 1					
6.36	5.013 x 10 ⁻⁴	84.33	2.948 x 10 ⁻²	328.56	7.641 x 10 ^{-2*}
7.24	7.131	91.92	3.217	337.99	7.700
8.16	7.105	99.39	3.475	346.58	7.735
9.31	8.552	107.09	3.742	CURVE 2	
10.35	9.785	115.16	4.020	400	7.869 x 10 ⁻²
11.42	1.126 x 10 ⁻³	122.74	4.273	450	7.983
12.49	1.354	Series 5		500	8.076
13.64	1.649	130.43	4.523	550	8.156
14.90	1.955	138.70	4.775	600	8.227
16.27	2.421	147.25	5.030	650	8.291
17.79	2.949	155.99	5.268	700	8.351
19.52	3.603	165.06	5.501	750	8.408
21.20	4.426	174.35	5.727	800	8.462
Series 2					
15.54	2.190	Series 6		850	8.514
16.87	2.627	177.48	5.791*	900	8.564
18.42	3.174	186.19	5.979	950	8.614
20.17	3.866	194.78	6.153*	1000	8.662
22.33	4.735	203.32	6.311	1050	8.709*
24.72	5.858	212.31	6.467	1100	8.756*
27.55	7.169	221.54	6.611*	1150	8.802*
30.52	8.555	230.64	6.740	1200	8.848
33.55	9.963	Series 7		1250	8.893*
36.59	1.146 x 10 ⁻²	239.84	6.877*	1300	8.938*
40.66	1.308	245.45	6.936*	1350	8.983*
44.92	1.483	254.80	7.046*	1400	9.027
49.57	1.668	263.29	7.139	1450	9.071*
Series 3					
53.15	1.803	272.50	7.239*	1500	9.115
58.44	1.999	281.86	7.319	1550	9.159*
64.37	2.221	291.18	7.397*	1600	9.249
70.77	2.446	300.40	7.464	1650	9.249*
77.39	2.684	309.76	7.534	1700	9.249*
84.82	2.966	319.15	7.590	1750	9.249*
				1800	9.249

* Not shown on Plot

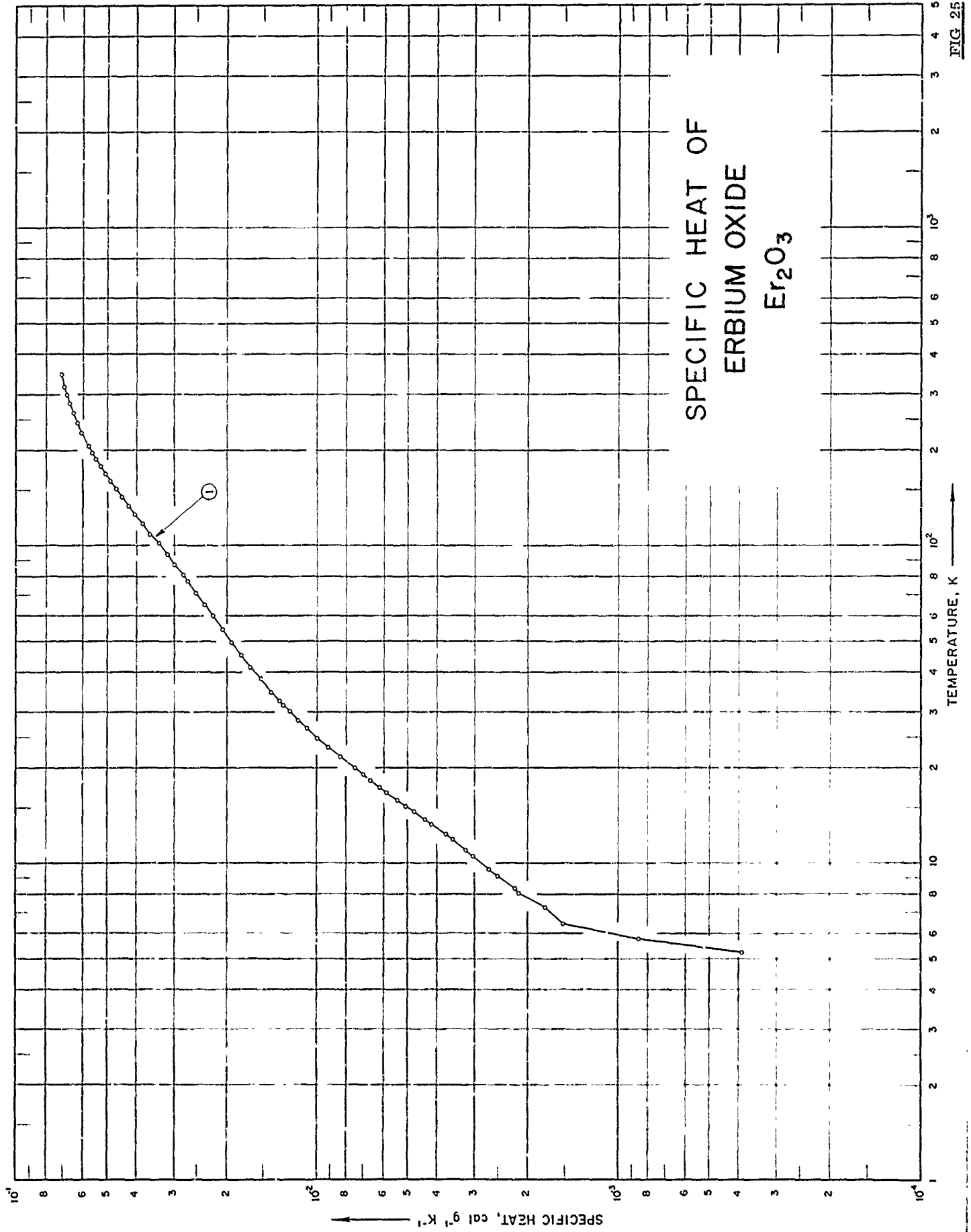

FIG 25

SPECIFICATION TABLE NO. 25 SPECIFIC HEAT OF ERBIUM OXIDE Er₂O₃

[For Data Reported in Figure and Table No. 25]

Curve No.	Ref. No.	Year	Temp. Range, K	Reported Error, %	Name and Specimen Designation	Composition (weight percent), Specifications and Remarks
1	72	1962	5-346	0.1		99.9 Er ₂ O ₃ , 0.035 Tm, 0.010 Ca, 0.010 Dy, 0.010 Si, and 0.003 Ho; powder specimen; sample supplied by the Michigan Chemical Co; measured in helium atmosphere.

DATA TABLE NO. 25 SPECIFIC HEAT OF ERBIUM OXIDE, Er_2O_3
 [Temperature, T, K, Specific Heat, C_p , Cal $\text{g}^{-1}\text{K}^{-1}$]

T	C_p	T	C_p	T	C_p
CURVE 1		CURVE 1 (cont.)		CURVE 1 (cont.)	
Series 1					
80.89	2.776×10^{-2}	18.38	6.625×10^{-3}	272.02	6.551×10^{-1} *
87.29	2.959	20.02	7.485	281.19	6.638
94.21	3.145	21.67	8.313	290.33	6.716
101.76	3.348	23.31	9.155	299.53	6.789
109.79	3.571	24.96	9.971	308.44	6.855*
117.87	3.791	26.64	1.076×10^{-2}	317.78	6.920
126.06	4.013	28.39	1.154	327.16	6.980*
134.50	4.235	30.23	1.237	335.58	7.038*
143.25	4.455	32.51	1.333	345.64	7.085
151.94	4.664	Series 4			
160.54	4.857	28.46	1.157*		
169.21	5.046	31.56	1.290		
178.22	5.226	34.66	1.417		
Series 2					
5.26	3.895×10^{-4}	38.06	1.542		
5.78	8.549	41.65	1.661		
6.46	1.514×10^{-3}	45.47	1.783		
7.28	1.749	49.75	1.912		
8.06	2.136	54.76	2.056		
9.12	2.502	60.14	2.207		
10.53	3.033	65.47	2.355		
11.98	3.542	71.16	2.502		
13.32	4.151	77.79	2.680		
14.58	4.766	84.94	2.893*		
15.89	5.398	179.34	5.249*		
17.43	6.164	188.84	5.422		
19.07	6.991	197.78	5.584		
Series 3					
8.33	2.191×10^{-3}	207.09	5.736		
9.57	2.685	Series 5			
11.00	3.195	208.99	5.764*		
12.41	3.728	217.95	5.900*		
13.76	4.371	227.01	6.026		
15.19	5.048	236.11	6.143*		
16.76	5.840	244.97	6.264		
		253.90	6.360*		
		262.98	6.457		

* Not shown on Plot

FIG 26

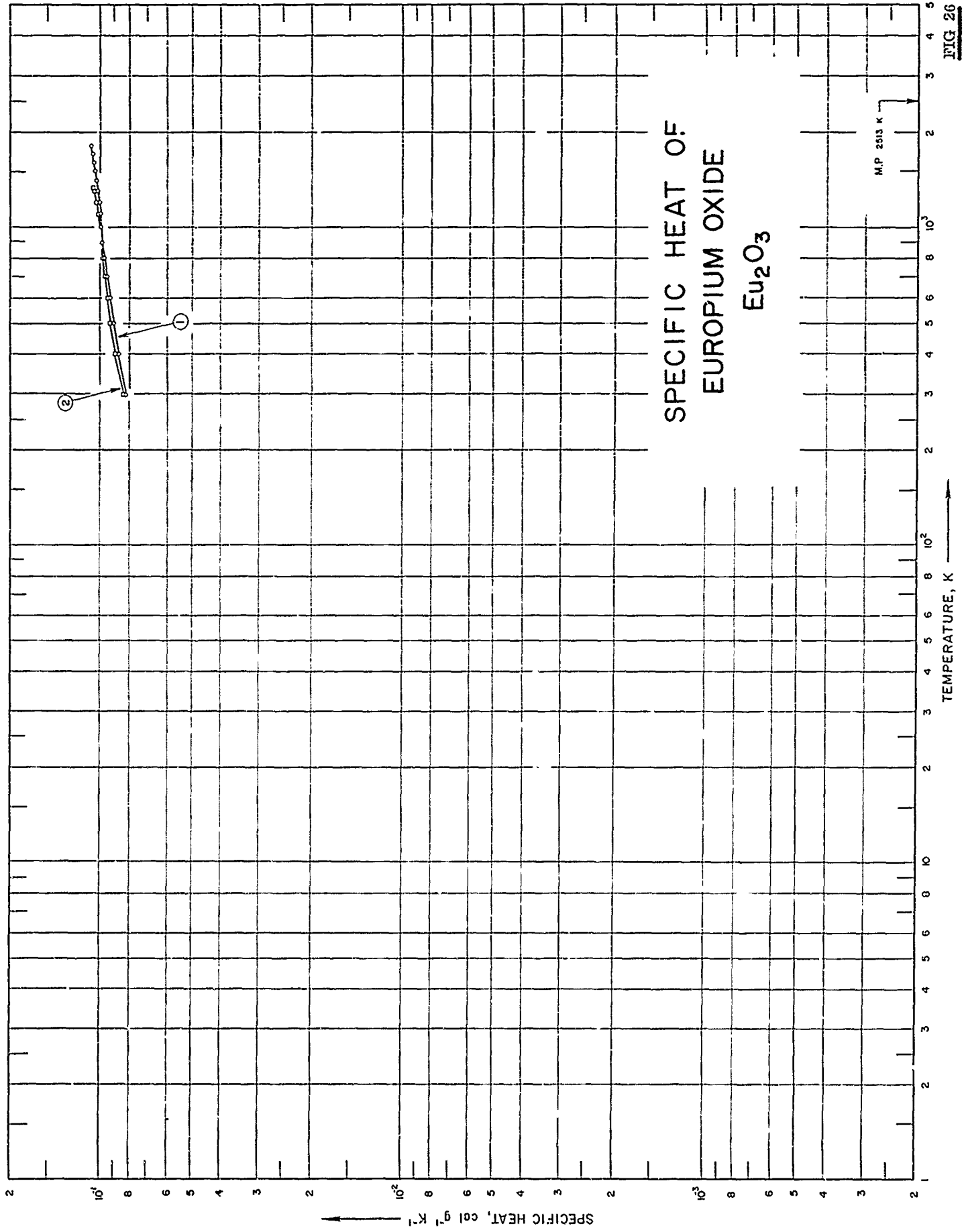

Reference: J. Chem. Phys. 17, 157 (1949)

SPECIFICATION TABLE NO. 26 SPECIFIC HEAT OF EUROPIUM OXIDE Eu_2O_3

[For Data Reported in Figure and Table No. 26]

Curve No.	Ref. No.	Year	Temp. Range, K	Reported Error, %	Name and Specimen Designation	Composition (weight percent), Specifications and Remarks
1	73	1962	298-1800	0.2		99.9 Eu_2O_3 ; monoclinic; measured in helium atmosphere.
2	73	1962	298-1350	0.2		99.9 Eu_2O_3 ; cubic; measured in helium atmosphere.

DATA TABLE NO. 26 SPECIFIC HEAT OF EUROPIUM OXIDE, Eu_2O_3
 [Temperature, T, K; Specific Heat, C_p , Cal $\text{g}^{-1}\text{K}^{-1}$]

CURVE 1	
298	8.295×10^{-2}
300	8.307*
400	8.779
500	9.096
600	9.352
700	9.580
800	9.792
895	9.986*
895	9.884*
900	9.890*
1000	1.001×10^{-1}
1100	1.013
1200	1.025
1300	1.036
1400	1.048
1500	1.060
1600	1.072
1700	1.084
1800	1.095

CURVE 2	
298	8.463×10^{-2}
300	8.479*
400	9.023
500	9.342
600	9.572
700	9.760
800	9.926
900	1.008×10^{-1} *
1000	1.022*
1100	1.036
1200	1.050
1300	1.063
1350	1.070

* Not shown on Plot

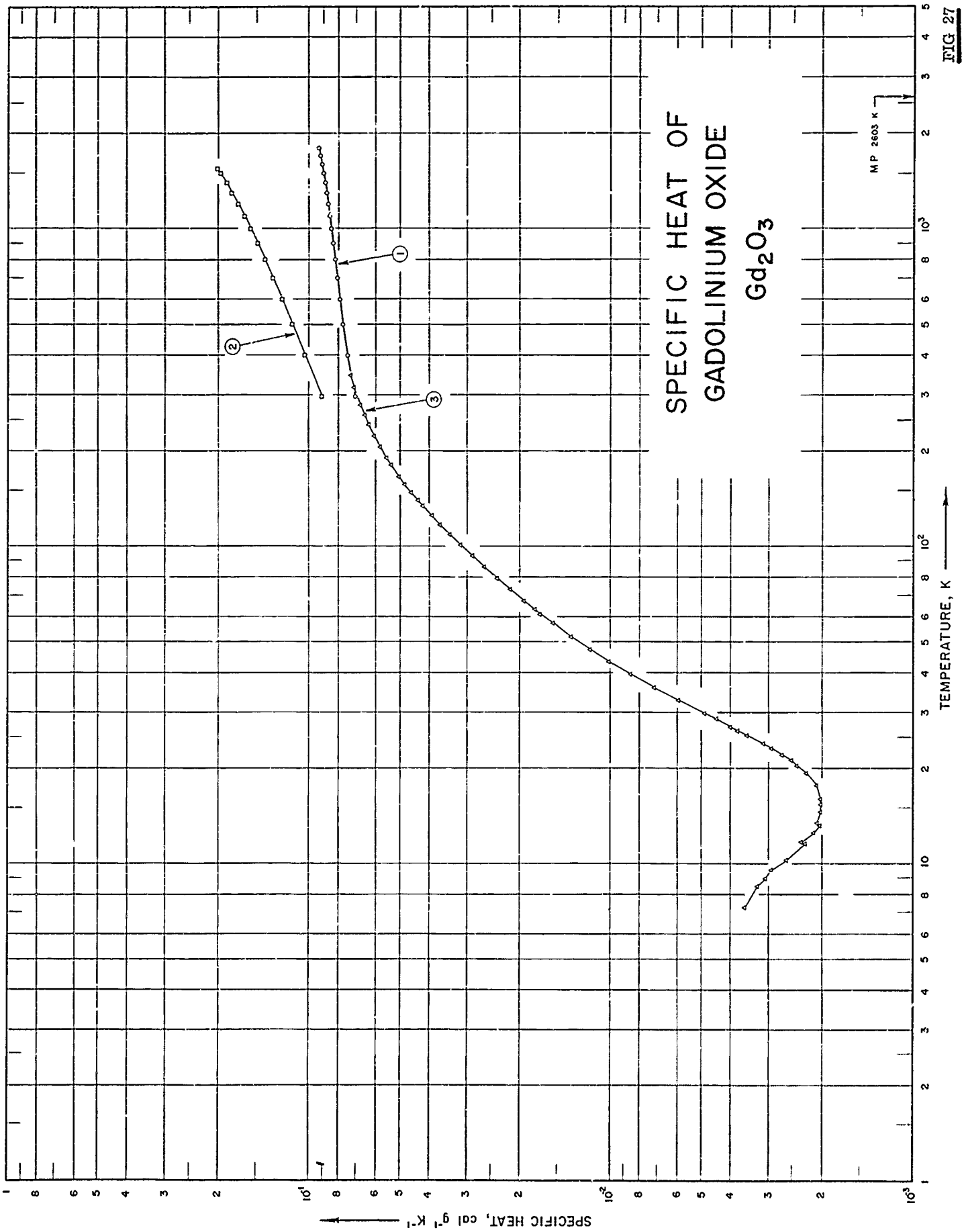

FIG 27

SPECIFICATION TABLE NO. 27 SPECIFIC HEAT OF GADOLINIUM OXIDE Gd_2O_3

[For Data Reported in Figure and Table No. 27]

Curve No.	Ref. No.	Year	Temp. Range, K	Reported Error, %	Name and Specimen Designation	Composition (weight percent), Specifications and Remarks
1	73	1962	298-1800	0.2		99.9 Gd_2O_3 ; monoclinic; measured in helium atmosphere.
2	73	1962	298-1550	0.2		99.9 Gd_2O_3 ; cubic; measured in helium atmosphere.
3	72	1962	7-346	0.1		99.90 Gd_2O_3 , 0.045 Y, 0.020 Si, 0.010 Ca, and 0.0075 Eu; sample supplied by Michigan Chemical Co; pelleted under pressure of 2000 - 4000 psi; fired at 1170 K; measured in helium atmosphere.

DATA TABLE NO. 27 SPECIFIC HEAT OF GADOLINIUM OXIDE, Gd₂O₃[Temperature, T, K; Specific Heat C_p, Cal g⁻¹K⁻¹]

T	C _p	T	C _p	T	C _p	T	C _p
CURVE 1		CURVE 3 (cont.)		CURVE 3 (cont.)		CURVE 3 (cont.)	
298	7.028 x 10 ⁻²	186.97	4.822 x 10 ⁻²	32.71	5.939 x 10 ⁻³	269.20	6.681 x 10 ⁻² *
300	7.040	165.89	5.035	35.95	7.170	278.61	3.781
400	7.478	Series 2		39.52	8.560	288.05	6.860*
500	7.734	7.28	3.600 x 10 ⁻³	43.30	1.005 x 10 ⁻²	297.72	6.955*
600	7.917	8.48	3.274	47.34	1.167	307.61	7.037
700	8.066	8.98	3.062	51.97	1.351	317.42	7.115
800	8.197	10.21	2.620	57.25	1.555	327.16	7.183*
900	8.318	11.71	2.342	63.11	1.784	336.80	7.250*
1000	8.432	13.18	2.030	Series 5			
1200	8.649	14.53	2.028	61.16	1.710		
1300	8.754	16.00	2.022	67.25	1.940		
1400	8.857	17.63	2.088	73.10	2.185		
1500	8.959	19.32	2.251	Series 6			
1600	9.061	21.14	2.527	79.21	2.380		
1700	9.161	23.11	2.935	86.08	2.640		
1800	9.262	25.48	3.542	93.33	2.886		
CURVE 2		28.58	4.488	101.12	3.150		
298	9.052 x 10 ⁻²	Series 3		116.95	3.679		
300	9.084*	8.45	3.230*	125.30	3.943		
400	1.039 x 10 ⁻¹	9.52	2.941	134.35	4.212		
500	1.141	10.56	2.557*	143.89	4.480*		
600	1.233	11.56	2.273	153.66	4.737*		
700	1.319	12.52	2.138	163.29	4.974*		
800	1.402	13.50	2.066*	172.50	5.183*		
900	1.484	14.48	2.028*	181.55	5.377		
1000	1.565	15.45	2.014*	190.55	5.553		
1100	1.645	16.55	2.036*	Series 7			
1200	1.725	17.77	2.099*	196.38	5.658*		
1300	1.804	19.03	2.218*	205.30	5.815		
1400	1.884	20.45	2.414	214.55	5.967*		
1500	1.963	22.04	2.701	223.70	6.105		
1550	2.002	23.92	3.128	232.62	6.232*		
CURVE 3		26.34	3.790	241.46	6.359		
Series 1		Series 4		250.54	6.469*		
139.94	4.375 x 10 ⁻²	27.01	3.995	259.86	6.579		
148.25	4.599	29.80	4.894				

* Not shown on Plot

FIGURE SHOWS ONLY 1 OF THE CURVES REPORTED IN TABLE

SPECIFIC HEAT OF
GALLIUM OXIDE
 Ga_2O_3

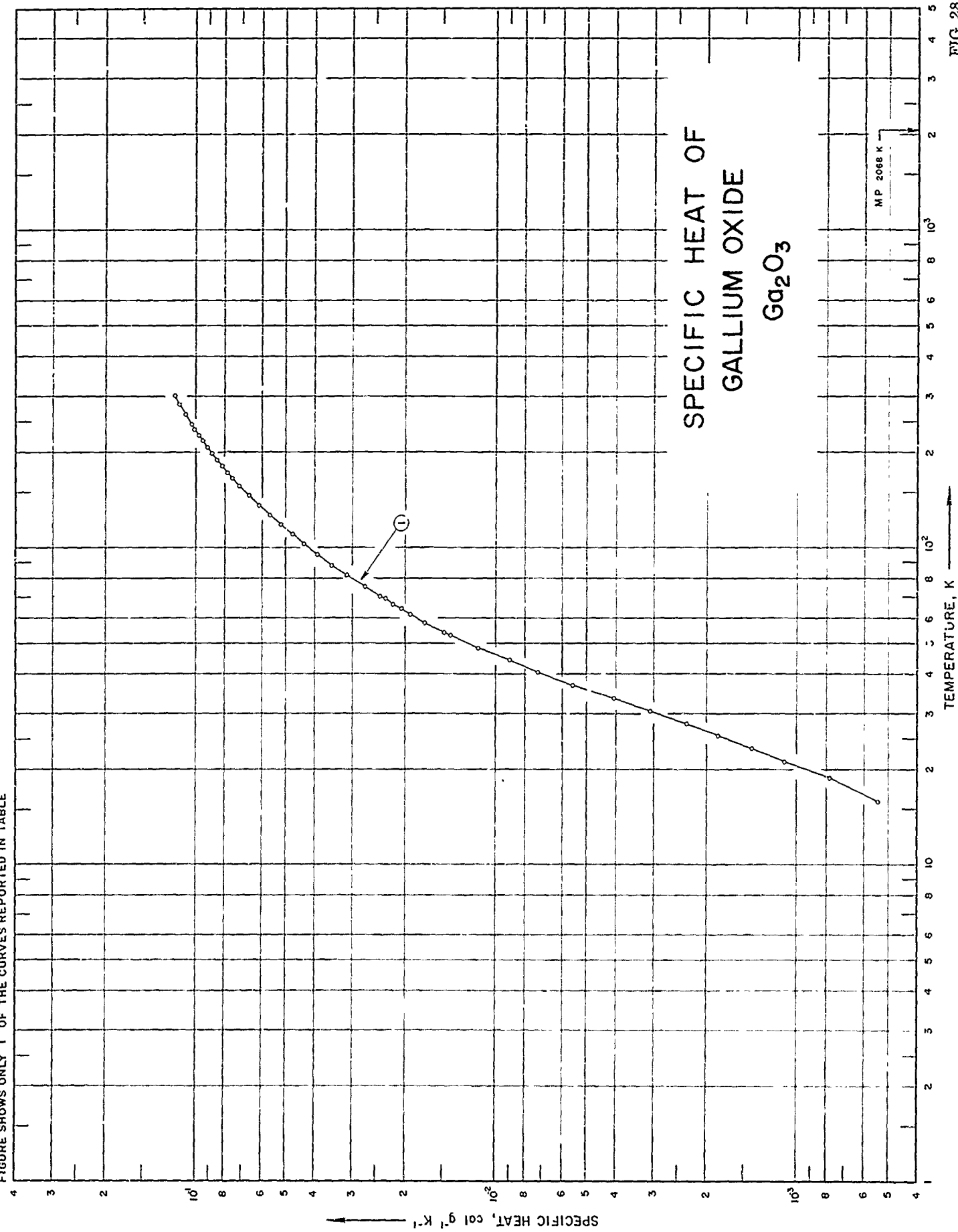

SPECIFICATION TABLE NO. 28 SPECIFIC HEAT OF GALLIUM OXIDE Ga₂O₃

[For Data Reported in Figure and Table No. 28]

Curve No.	Ref. No.	Year	Temp. Range, K	Reported Error, %	Name and Specimen Designation	Composition (weight percent), Specifications and Remarks
1	74	1952	15-300			98.67 βGa ₂ O ₃ , 1.16 SiO ₂ , 0.1 ZnO, 0.05 each Fe ₂ O ₃ , Al ₂ O ₃ , 0.02 SnO ₂ , 0.01 NiO, 0.008 CuO, 0.001 each V ₂ O ₅ , MoO ₃ , PbO, and MnO; corrected for impurities.
2	75	1958	53-298			99.9 Ga ₂ O ₃ , 0.05 ZnO, <0.01 other impurities.

DATA TABLE NO. 28 SPECIFIC HEAT OF GALLIUM OXIDE, Ga₂O₃
 [Temperature, T, K; Specific Heat, C_p, Cal g⁻¹K⁻¹]

T	C _p	T	C _p
	<u>CURVE 1</u>		<u>CURVE 1 (cont.)</u>
15.82	5.39 x 10 ⁻⁴	226.86	9.742 x 10 ⁻²
18.89	7.79	235.78	1.001 x 10 ⁻¹
21.22	1.10 x 10 ⁻³	247.01	1.035
23.43	1.41	254.44	1.056*
25.64	1.84	264.03	1.085*
27.94	2.34	272.90	1.111*
30.60	3.08	273.47	1.111*
33.56	4.07	283.04	1.135
36.91	5.559	292.26	1.159*
40.54	7.218	300.79	1.174
44.29	8.979		
48.61	1.150 x 10 ⁻²		
53.02	1.417		
54.23	1.485		
58.08	1.721		
58.60	1.762*		
61.78	1.922		
64.15	2.061		
66.61	2.200		
69.27	2.331		
69.65	2.343*		
70.54	2.414		
70.59	3.396*		
75.54	2.721*		
76.45	2.774		
82.03	3.127		
83.34	3.206*		
88.46	3.500*		
89.07	3.537*		
95.37	3.900		
103.09	4.341		
110.41	4.751		
118.32	5.192		
127.15	5.666		
136.41	6.119		
146.70	6.631		
156.80	7.122		
165.76	7.517		
173.88	7.859		
182.01	8.184		
189.83	8.493		
198.92	8.813		
207.91	9.107		
217.62	9.464		
		<u>CURVE 2</u>	
		53.81	1.486 x 10 ⁻²
		58.36	1.747
		62.79	2.002
		67.37	2.271
		71.99	2.547
		76.45	2.807
		80.29	3.047
		84.16	3.266
		94.92	3.898
		105.09	4.489
		114.63	5.016
		124.55	5.554
		135.99	6.146
		145.48	6.626
		155.76	7.112
		165.77	7.560
		175.70	7.992
		186.26	8.424
		196.26	8.803
		206.43	9.182
		216.26	9.512
		226.28	9.854
		236.27	1.016 x 10 ⁻¹
		246.10	1.044
		256.50	1.076
		266.30	1.110
		276.63	1.126
		286.83	1.149
		296.34	1.173
		298.15	1.175

* Not shown on Plot

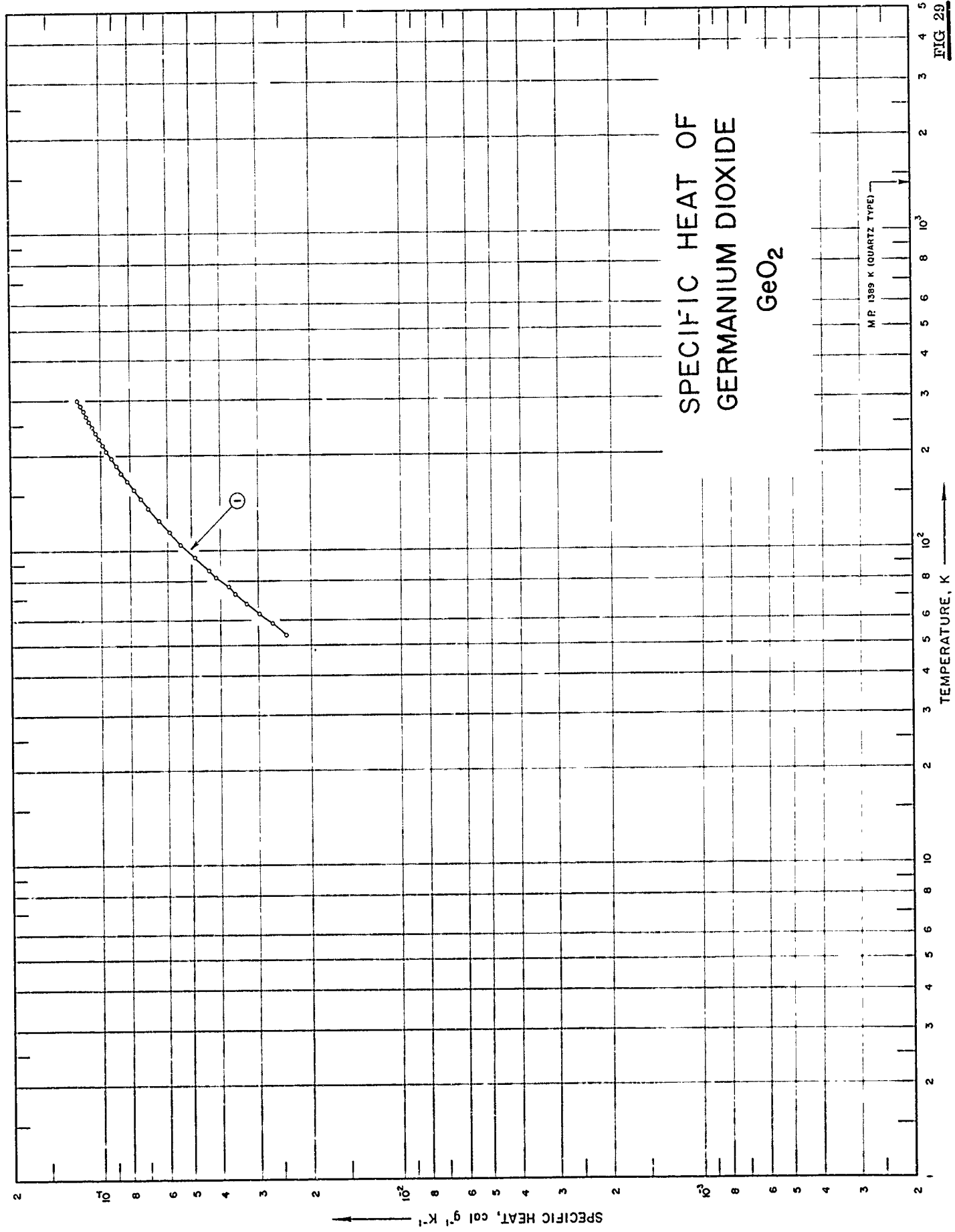

FIG 29

SPECIFICATION TABLE NO. 29 SPECIFIC HEAT OF GERMANIUM DIOXIDE GeO₂

[For Data Reported in Figure and Table No. 29]

Curve No.	Ref. No.	Year	Temp. Range, K	Reported Error, %	Name and Specimen Designation	Composition (weight percent), Specifications and Remarks
1	75	1955	53-298			99.99 GeO ₂ .

DATA TABLE NO. 29 SPECIFIC HEAT OF GERMANIUM DIOXIDE, GeO_2 [Temperature, T, K; Specific Heat, C_p , Cal $\text{g}^{-1}\text{K}^{-1}$]

T	C_p
CURVE 1	
53.97	2.413×10^{-2}
58.36	2.682
62.88	2.969
67.42	3.260
72.13	3.553
76.51	3.744
81.73	4.126
86.03	4.370
94.30	4.872
104.51	5.421
114.50	5.903
124.61	6.396
136.30	6.929
145.73	7.348
155.95	7.758
166.05	8.147
176.03	8.513
186.14	8.867
196.08	9.185
206.48	9.535
216.39	9.837
226.11	1.013×10^{-1}
236.21	1.040
245.77	1.065
256.32	1.095
266.51	1.119
276.41	1.142
286.79	1.165*
296.24	1.188*
298.15	1.190

* Not shown on Plot

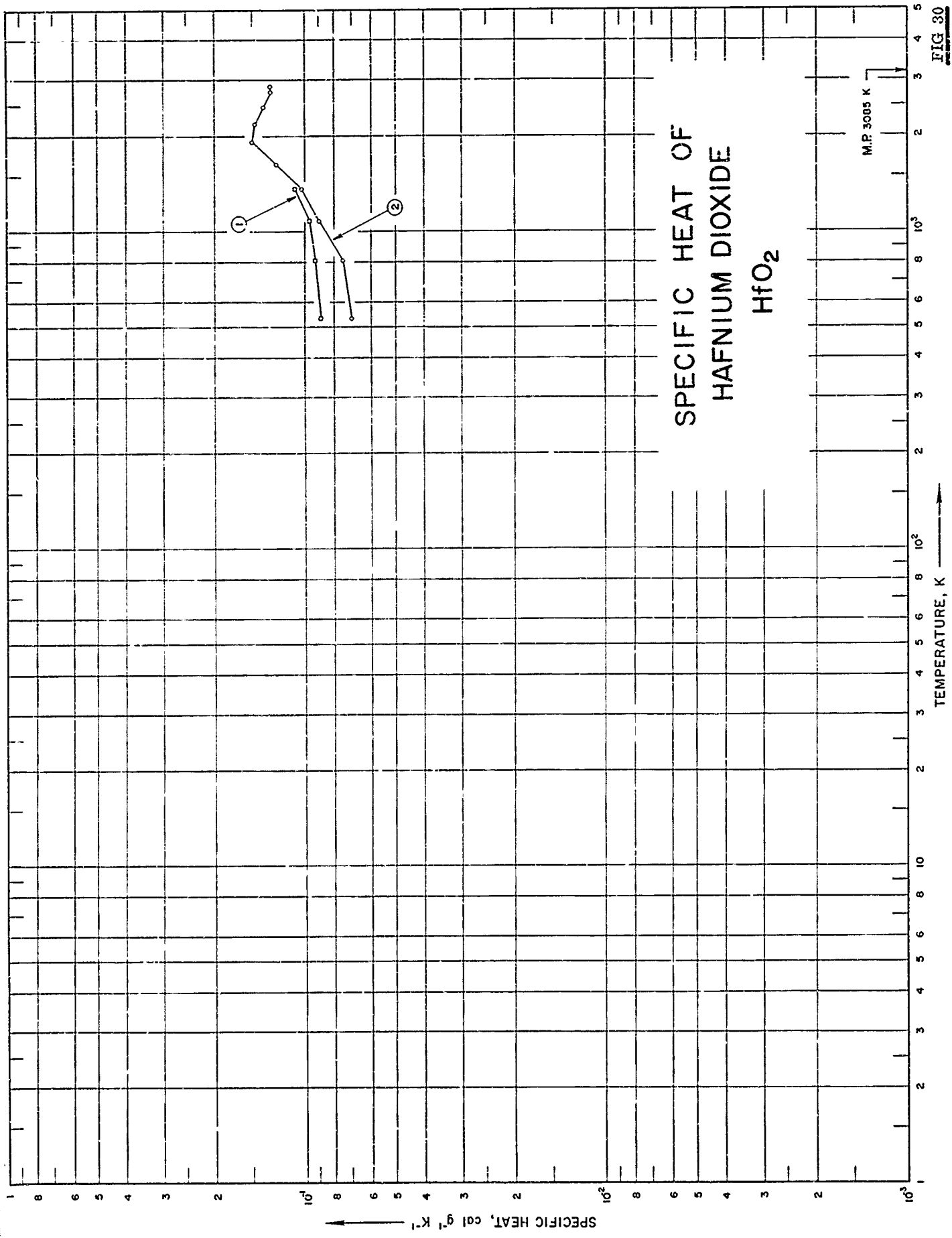

FIG 30

SPECIFICATION TABLE NO. 30 SPECIFIC HEAT OF HAFNIUM DIOXIDE HfO_2

[For Data Reported in Figure and Table No. 30]

Curve No.	Ref. No.	Year	Temp. Range, K	Reported Error, %	Name and Specimen Designation	Composition (weight percent), Specifications and Remarks
1	76	1961	533-1366	5.0		97.0 HfO_2 , 2.3 Zr; sample made by spraying powdered ZrO_2 using powder gun with 90 $\text{ft}^3 \text{hr}^{-1} \text{N}_2$, 10 $\text{ft}^3 \text{hr}^{-1} \text{H}_2$ plasma gas and 10 $\text{ft}^3 \text{hr}^{-1}$ carrier gas; density 524 lb ft^{-3} .
2	48	1962	533-2894			Before exposure: 82.0 Hf, 2.5 Fe, 0.3 Mg, 0.10 Ca, 0.10 Ti; after exposure: 84.0 Hf, 0.5a C; sample supplied by Zirconium Corp. of America; crushed in a hardened steel mortar to pass 100-mesh screen; pressed and sintered; density at 25 C, before exposure: apparent density (ASMT method B3; 1-58) 561 lb ft^{-3} , true density (by immersion in xylene) 595 lb ft^{-3} ; after exposure: apparent density 557 lb ft^{-3} , true density 601 lb ft^{-3} .

DATA TABLE NO. 30 SPECIFIC HEAT OF HAFNIUM DIOXIDE HfO_2 [Temperature, T, K. Specific Heat, C_p , Cal $\text{g}^{-1}\text{K}^{-1}$]

T	C_p
<u>CURVE 1</u>	
533.15	8.85×10^{-2}
810.93	9.25
1088.71	9.66
1366.48	1.08×10^{-1}
<u>CURVE 2</u>	
533.15	7.0×10^{-2}
810.93	7.5
1088.71	9.0
1366.48	1.03×10^{-1}
1644.26	1.25
1922.04	1.50
2199.82	1.47
2477.59	1.38
2755.37	1.30
2894.26	1.31

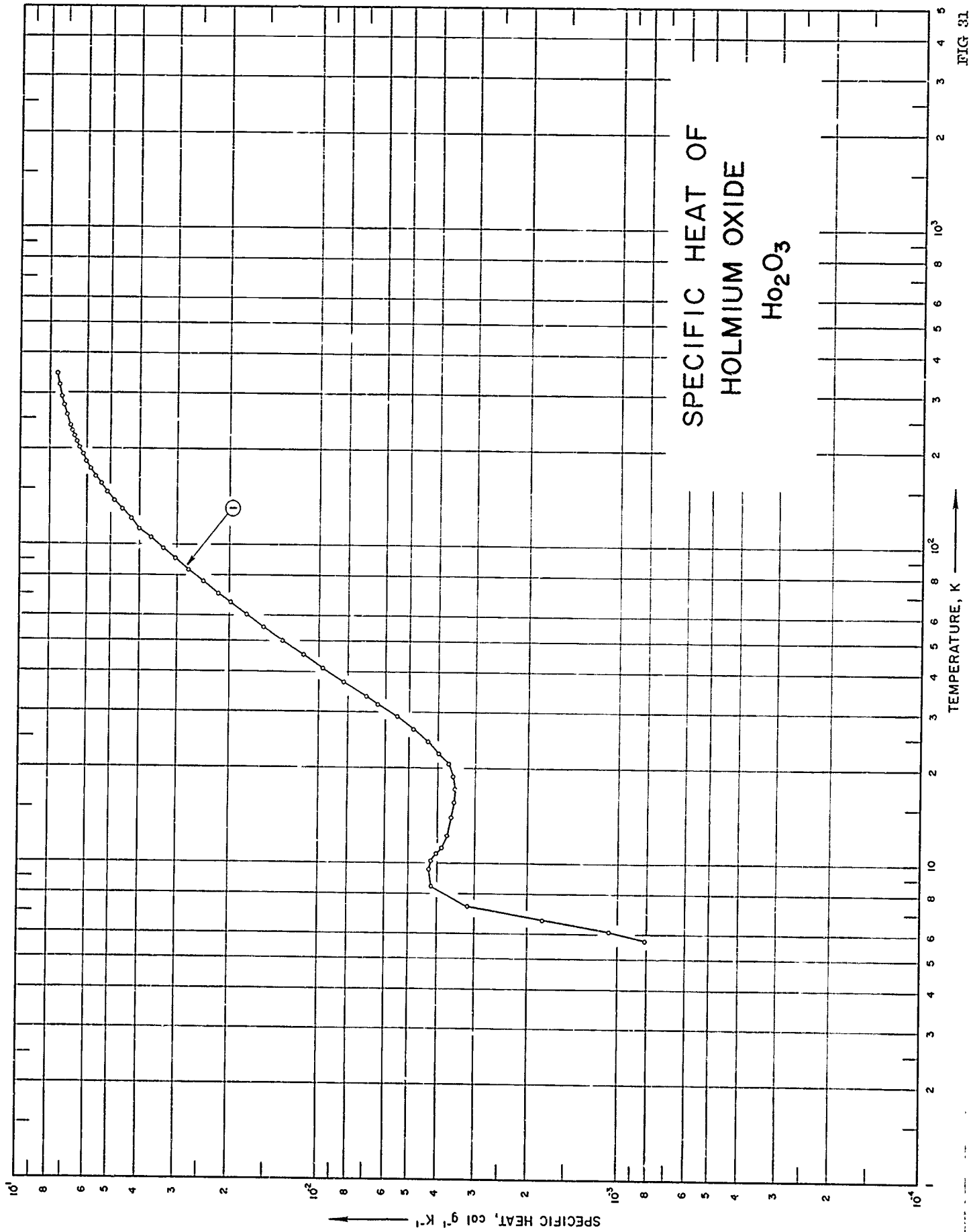

FIG. 31

SPECIFICATION TABLE NO. 31 SPECIFIC HEAT OF HOLMIUM OXIDE Ho_2O_3

[For Data Reported in Figure and Table No. 31]

Curve No.	Ref. No.	Year	Temp. Range, K	Reported Error, %	Name and Specimen Designation	Composition (weight percent), Specifications and Remarks
1	72	1963	6-346	0.1		99.9 Ho_2O_3 , 0.010 Ca, 0.010 Er, and 0.010 Si; powder specimen; sample supplied by the Michigan Chemical Co, measured in helium atmosphere.

DATA TABLE NO. 31 SPECIFIC HEAT OF HOLMIUM OXIDE, Ho₂O₃[Temperature, T, K; Specific Heat, C_p, Cal g⁻¹K⁻¹]

T	C _p	T	C _p
CURVE 1		CURVE 1 (cont.)	
Series 1			
70.63	2.159 x 10 ⁻²	5.75	8.098 x 10 ⁻⁴
77.08	2.430	6.11	1.063 x 10 ⁻³
83.72	2.722	6.64	1.773
90.54	3.075	7.32	3.157
97.87	3.314	8.49	4.184
105.81	3.637	9.61	4.248
113.89	3.960	10.84	4.020
121.35	4.248	12.36	3.713
129.99	4.560	14.00	3.607
138.60	4.846	15.62	3.522
147.16	5.113	17.20	3.501
155.96	5.362	18.81	3.552
165.02	5.595	20.58	3.687
174.24	5.809	22.39	3.962
183.42	6.000	24.35	4.303
192.85	6.177	26.58	4.811
202.33	6.330	29.09	5.486
211.49	6.465	31.85	6.338
220.62	6.590		
Series 2			
229.08	6.696	10.20	4.195
238.25	6.796	11.26	3.853
247.41	6.886	12.49	3.697
256.66	6.974	13.86	3.616
267.87	7.053	15.35	3.530
275.00	7.122	33.61	6.910
284.06	7.185	37.25	8.223
293.10	7.243	41.08	9.644
302.21	7.296	45.31	1.123 x 10 ⁻²
311.55	7.344	50.10	1.319
320.91	7.400	55.32	1.528
329.92	7.439	60.63	1.747
338.42	7.484	66.18	1.977
346.71	7.503	72.31	2.227
		79.44	2.533
Series 3			
Series 4			

Not shown on Plot

FIG 32

SPECIFIC HEAT OF IRON(OUS) OXIDE FeO

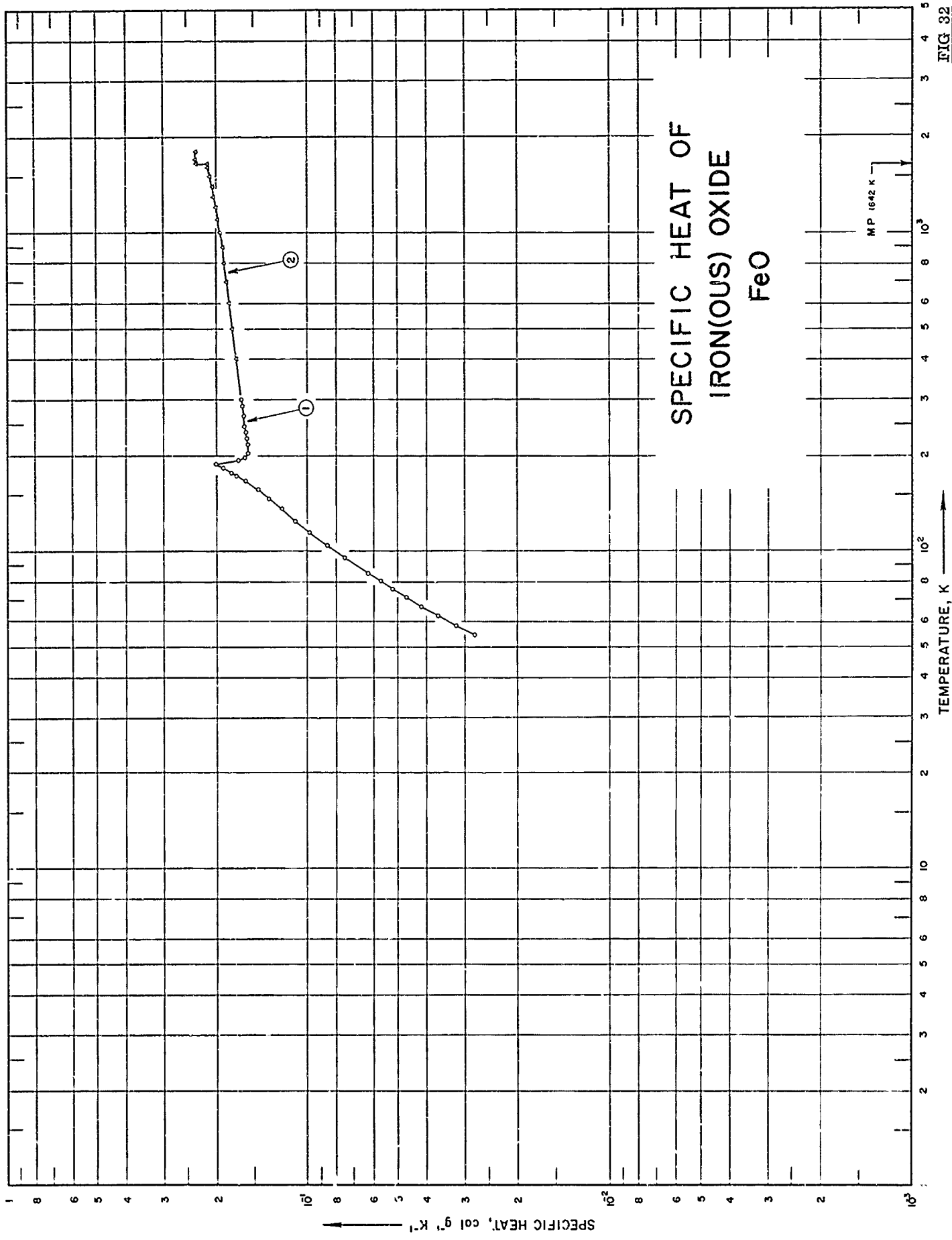

SPECIFICATION TABLE NO. 32 SPECIFIC HEAT OF IRON (OUS) OXIDE $Fe_{0.847}O$

[For Data Reported in Figure and Table No. 32]

Curve No.	Ref. No.	Year	Temp. Range, K	Reported Error, %	Name and Specimen Designation	Composition (weight percent), Specifications and Remarks
1	77	1951	54-298			76.60 Fe, 23.18 O ₂ , 0.17 SiO ₂ .
2	78	1951	298-1800			76.60 Fe, 23.18 O, 0.17 Si; heated 4.9 to 9.3 days at 1150 K and quenched.

DATA TABLE NO. 32 SPECIFIC HEAT OF IRON(OUS) OXIDE, Fe_{0.87}O[Temperature, T, K; Specific Heat, C_p, Cal g⁻¹K⁻¹]

CURVE 1		CURVE 2	
T	C _p	T	C _p
54.37	2.803 x 10 ⁻²	298.55	1.670 x 10 ⁻¹
58.24	3.212	300	1.672*
62.44	3.693	400	1.747
66.91	4.210	500	1.789
71.42	4.725	600	1.840
75.91	5.247	700	1.876
80.22	5.760	800	1.910
84.96	6.322	900	1.942
94.95	7.511	1000	1.973
104.72	8.656	1100	2.004
114.66	9.874	1200	2.034
124.81	1.104 x 10 ⁻¹	1300	2.064
135.97	1.235	1400	2.094
146.31	1.354	1500	2.123
155.93	1.473	1600	2.153
165.84	1.616	1650	2.168
167.52	1.646*	1650	2.366
172.56	1.736	1700	2.366
175.89	1.800*	1800	2.366
177.03	1.817*		
180.58	1.877*		
183.33	1.916		
185.54	1.944*		
185.92	1.961*		
187.67	2.019		
190.10	1.983*		
193.50	1.704		
196.32	1.633		
197.97	1.608*		
202.87	1.582*		
206.65	1.578*		
216.52	1.584		
226.21	1.595		
236.06	1.605		
245.84	1.614		
257.20	1.624*		
266.08	1.639*		
276.05	1.648*		
286.29	1.659		
296.46	1.665*		
298.16	1.669		

* Not shown on Plot

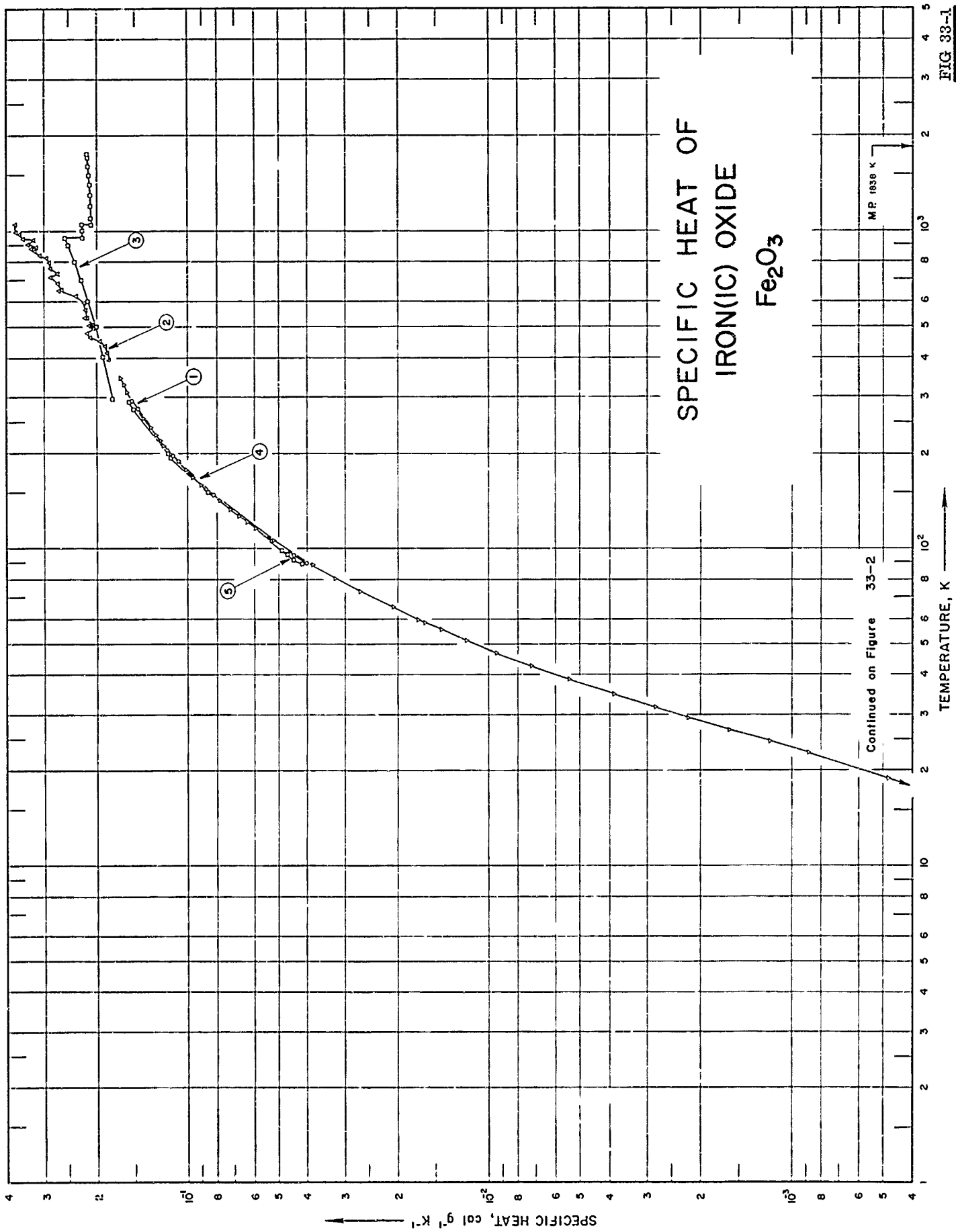
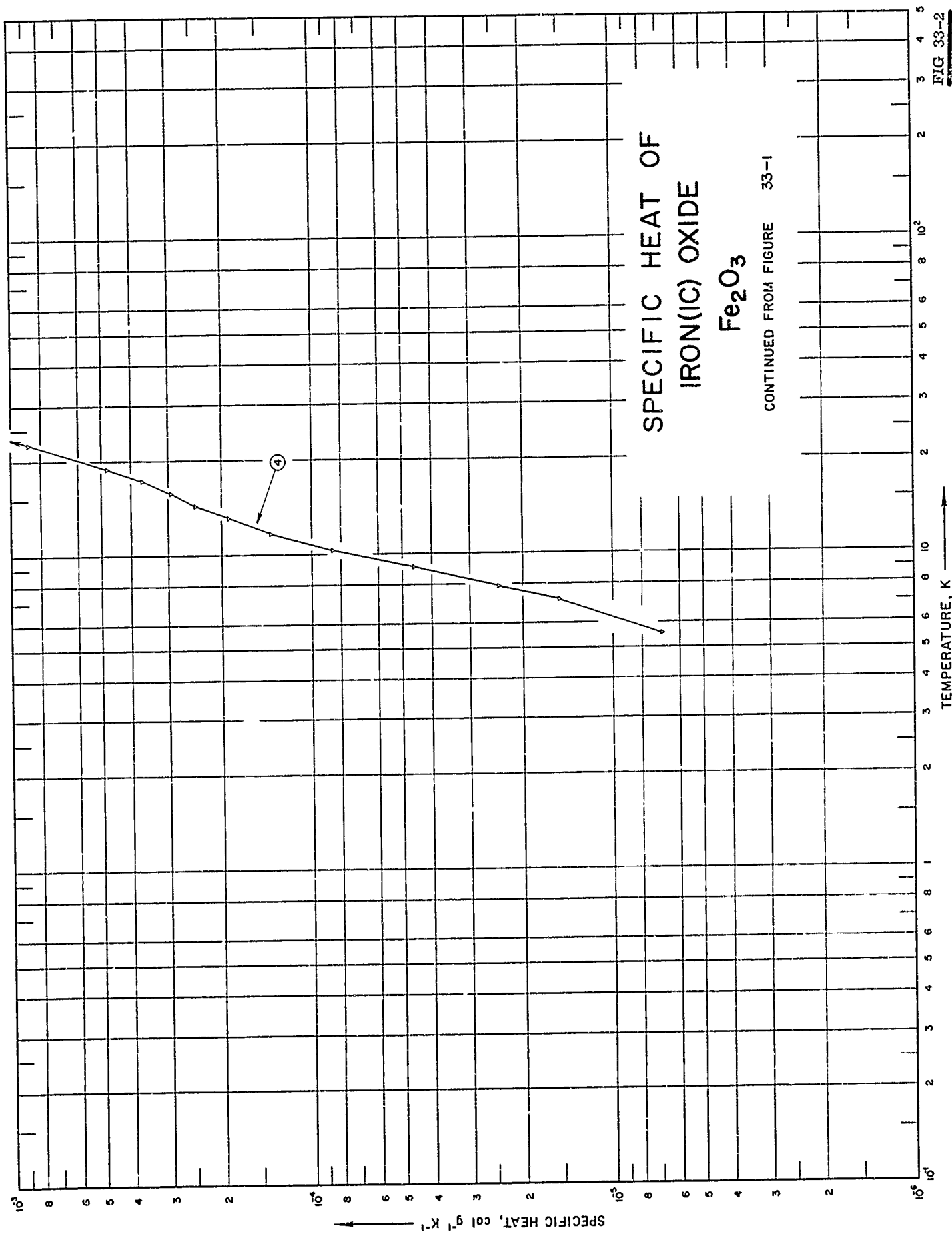

FIG 33-1



SPECIFIC HEAT OF
IRON(II) OXIDE
Fe₂O₃

CONTINUED FROM FIGURE 33-1

SPECIFICATION TABLE NO. 33 SPECIFIC HEAT OF IRON (IC) OXIDE Fe_2O_3

[For Data Reported in Figure and Table No. 33]

Curve No.	Ref. No.	Year	Temp. Range, K	Reported Error, %	Name and Specimen Designation	Composition (weight percent), Specifications and Remarks
1	18	1926	89-292			Specular; 99.2 Fe_2O_3 , 0.5 H_2O , and 0.5 SiO_2 .
2	79	1926	391-1051	≤ 0.5		98.73 Fe_2O_3 , 0.620 SiO_2 , 0.345 Mn, 0.117 Fe_3O_4 , 0.028 C, 0.027 S, and 0.02 P, finely powdered crystalline Fe_2O_3 .
3	78	1951	298-1750			69.86 Fe; prepared from reagent grade $FeCl_2$.
4	80	1959	5-345			0.01 Mn, < 0.01 Al, Co, Mg, Ni, and S, and < 0.001 Ca, Cu, and Sn.
5	18	1926	88-289			Kahlbaum's purity; 99.5 Fe_2O_3 and 0.5 H_2O .

DATA TABLE NO. 33 SPECIFIC HEAT OF IRON(II) OXIDE, FeO
 [Temperature, T, K; Specific Heat, C_p, Cal g⁻¹K⁻¹]

T	C _p	T	C _p	T	C _p	T	C _p	T	C _p		
<u>CURVE 1</u>											
89.8	4.04 × 10 ⁻²	Series 3 (cont.)		1600	2.162 × 10 ⁻¹	Series 2 (cont.)		CURVE 5 (cont.)			
90.3	4.14*	715.5	2.87 × 10 ⁻¹	1700	2.172	301.23	1.563 × 10 ⁻¹	194.3	1.141 × 10 ⁻¹		
90.5	4.10*	737.5	2.71	γ1750	2.178	310.20	1.592	198.5	1.162		
95.5	4.45	763	2.88	<u>CURVE 4</u>						274.9	1.521
148.4	8.27	799	2.91	Series 1						276.7	1.525*
186.9	1.082 × 10 ⁻¹	823	2.98	Series 3						286.9	1.551*
192.8	1.109*	840	3.14	58.61	1.636 × 10 ⁻²	10.31	8.453	289.4	1.561		
196.3	1.128	880	3.35	65.30	2.083	11.65	1.365 × 10 ⁻⁴				
275.9	1.477	904	3.42	73.20	2.683	13.02	1.885				
278.1	1.486*	Series 4									
289.1	1.534*	864	3.26	80.93	3.242	14.39	2.442				
291.9	1.539	870.5	3.20	88.57	3.837	15.72	2.937				
<u>CURVE 2</u>											
Series 2											
391.0	1.82 × 10 ⁻¹	889	3.22	96.83	4.470*	17.25	3.651				
393.5	1.84	936	3.28	106.36	5.202	18.97	4.803				
414.0	1.86	941	3.58	116.07	5.951	22.70	8.804				
450.5	1.97	991.5	3.76	121.39	6.356	24.65	1.169 × 10 ⁻³				
490.5	2.04*	1051	3.80	127.04	6.781	26.89	1.607				
493.0	2.07	<u>CURVE 3</u>									
508.0	2.07	Series 2									
533.0	2.17	α298.15	1.793 × 10 ⁻¹	177.24	1.017 × 10 ⁻¹	29.24	2.197				
Series 3											
419.2	1.87*	300	1.796*	185.88	1.068*	29.24	2.197				
435	1.89	400	1.922	194.32	1.115*	31.56	2.801				
463	2.11	500	2.044	202.65	1.160*	34.80	3.859				
479.5	2.17	600	2.163	210.85	1.202	38.75	5.424				
483.7	2.06*	700	2.281	219.61	1.245	42.76	7.239				
505.5	2.14	800	2.399	228.19	1.285	46.99	9.411				
535	2.22	900	2.516	Series 2							
567	2.20	α950	2.575	223.58	1.266*	51.51	1.194 × 10 ⁻²				
592.5	2.23	β950	2.254	232.31	1.304*	55.81	1.447				
626.5	2.36	γ1050	2.254	241.06	1.343*	59.71	1.709				
654.5	2.64	1100	2.106	258.22	1.413	<u>CURVE 5</u>					
682	2.72*	1200	2.118	266.75	1.446	88.3	4.12 × 10 ⁻²				
685.5	2.73	1300	2.128	275.38	1.478*	91.8	4.42				
701.5	2.70	1400	2.140	283.78	1.507*	95.8	4.65				
		1500	2.151	292.35	1.534*	98.3	4.85				
						150.3	8.58				

* Not shown on Plot

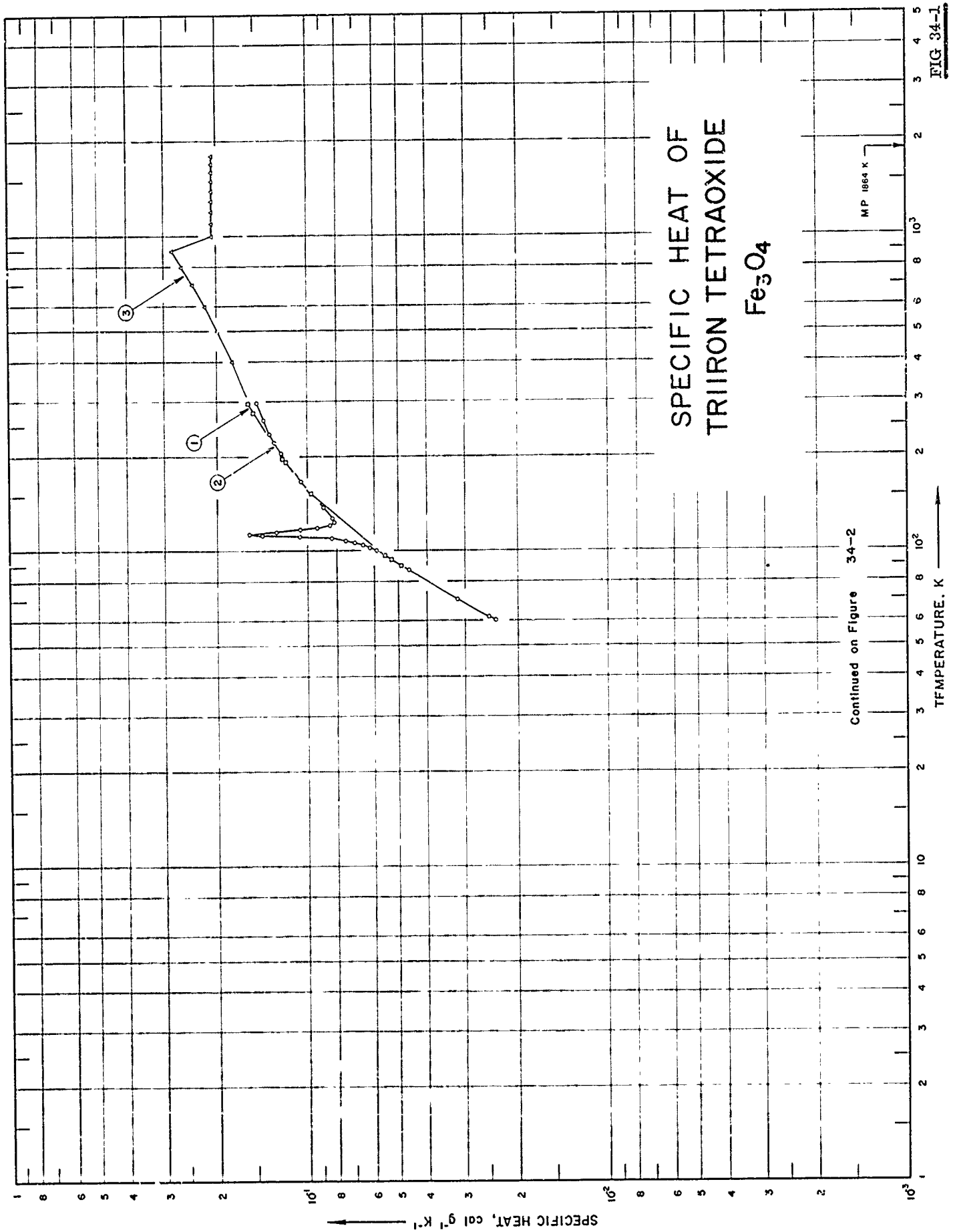
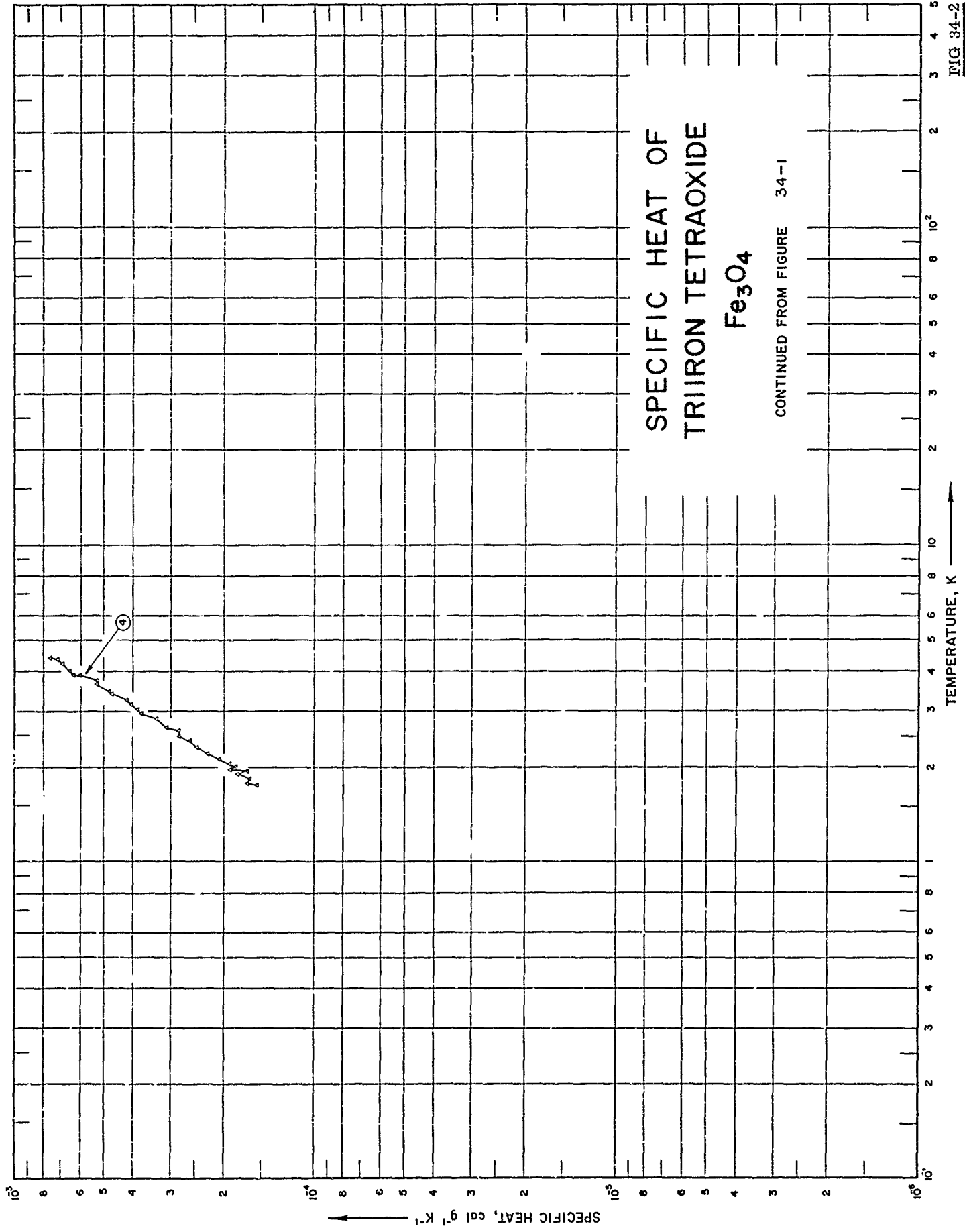

FIG 34-2

SPECIFIC HEAT OF
TRIIRON TETRAOXIDE
 Fe_3O_4

CONTINUED FROM FIGURE 34-1



SPECIFICATION TABLE NO. 34 SPECIFIC HEAT OF TRIRON TETRAOXIDE Fe_3O_4

[For Data Reported in Figure and Table No. 34]

Curve No.	Ref. No.	Year	Temp. Range, K	Reported Error, %	Name and Specimen Designation	Composition (weight percent), Specifications and Remarks
1	18	1926	90-295			99.00 Fe_3O_4 , 0.63 Fe_2O_3 , and 0.37 others.
2	65	1929	60-300			99.00 Fe_3O_4 , 0.63 Fe_2O_3 , and 0.37 others.
3	78	1951	298-1800			72.16 Fe, 27.54 O_3 , 0.22 SiO_2 ; prepared from ferric oxide by heating 8 hrs at 1630 K under vacuum.
4	81	1956	1.8-4.2			Natural magnetite crystal.

DATA TABLE NO. 34 SPECIFIC HEAT OF TRIRON TETRAOXIDE Fe_3O_4 [Temperature, T, K; Specific Heat, C_p , Cal $g^{-1} K^{-1}$]

T	CURVE 1		T	CURVE 2 (cont.)		T	CURVE 4 (cont.)	
	C_p	10^{-2}		C_p	10^{-1}		C_p	10^{-4}
90.0	4.88	10^{-2}	235.7	1.347	10^{-1}	2.966	3.778	10^{-4}
90.2	4.93		239.2	1.358*		3.068	3.871	
94.2	5.24		231.3	1.325*		3.167	4.081	
96.9	5.50		243.0	1.374*		3.269	4.241	
153.2	3.68		261.1	1.411		3.410	4.746	
193.5	1.186	10^{-1}	CURVE 3			3.483	4.839	
197.2	1.205		α 298.15			3.567	4.963*	
276.3	1.513		300	1.565*	10^{-1} *	3.667	5.360	
278.7	1.525*		400	1.569*		3.776	5.305	
292.1	1.558*		500	1.778		3.906	6.086	
295.0	1.570		600	1.986		4.059	6.609	
CURVE 2			700	2.193		4.231	6.955	
297.3	1.480	10^{-1}	800	2.402		4.416	7.264	
299.7	1.485*		900	2.610		4.427	7.677	
60.5	2.373	10^{-2}	1000	2.818		1.768	1.56	
62.0	2.492		1100	2.073		1.832	1.63*	
70.5	3.166		1200	2.073		1.907	1.80	
87.6	4.591		1300	2.073		1.970	1.90	
100.7	5.904		1400	2.073		2.050	1.96*	
103.0	6.210		1500	2.073		2.181	2.27*	
105.1	6.564		1600	2.073		2.273	2.471*	
107.0	6.950		1700	2.073		2.697	3.035*	
108.8	7.458		1800	2.073		2.732	3.200*	
110.4	8.314		CURVE 4			3.933	6.399	
112.0	1.063	10^{-1}	1.780	1.67	10^{-4}	4.150	6.906*	
113.6	1.422		1.845	1.65		4.363	7.247	
114.7	1.566		1.953	1.68				
115.9	1.274		2.011	1.83				
117.6	1.062		2.058	1.91				
119.4	9.294	10^{-2}	2.142	2.09				
121.8	8.413		2.211	2.29				
124.8	8.184		2.327	2.461				
127.5	8.275		2.437	2.609				
138.9	8.866*		2.511	2.815				
153.7	9.773		2.603	2.832				
167.5	1.052	10^{-1}	2.687	3.104				
191.4	1.165*		2.851	3.364				
206.2	1.235							
222.1	1.296							

Not shown on Plot

SPECIFIC HEAT OF
LANTHANUM OXIDE
La₂O₃

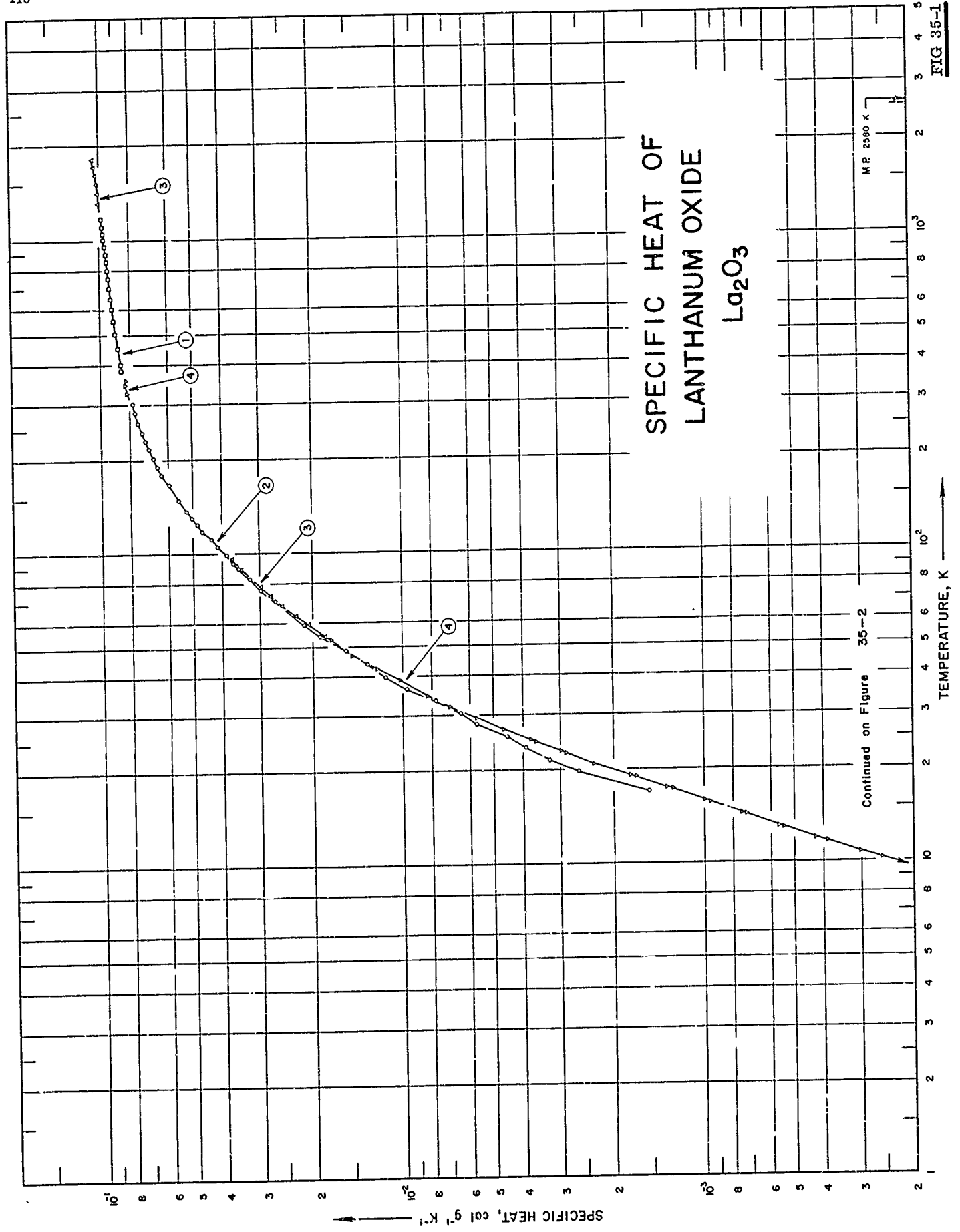
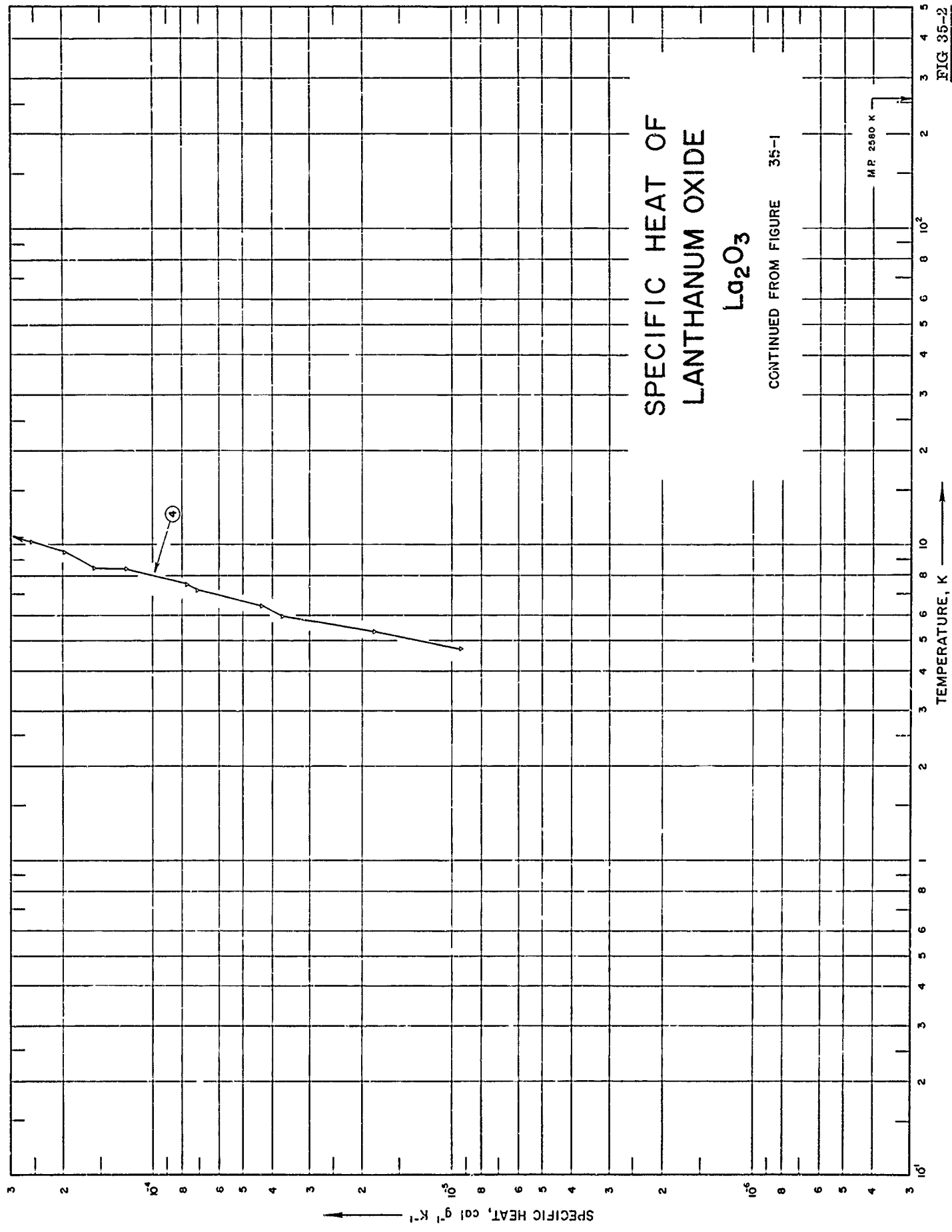

FIG 35-2



SPECIFIC HEAT, cal g⁻¹ K⁻¹

TEMPERATURE, K

SPECIFICATION TABLE NO. 35 SPECIFIC HEAT OF LANTHANUM OXIDE La_2O_3

[For Data Reported in Figure and Table No. 35]

Curve No.	Ref. No.	Year	Temp. Range, K	Reported Error, %	Name and Specimen Designation	Composition (weight percent), Specifications and Remarks
1	82	1951	383-1171			
2	83	1959	16-300			
3	84	1961	53-1800	0.1		99.997 La_2O_3 , 0.00015 Fe_2O_3 ; sample supplied by the Lindsay Chemical Co.; heated to constant weight at 950 C for 2 hrs in air to decompose hydroxide or carbonate.
4	72	1962	5-355	0.1		99.997 La_2O_3 ; measured under vacuum 99.997 La_2O_3 ; sample supplied by Lindsay Chemical Co.; pelleted under pressure 2000-4000 psi; fired at 1170 K; measured in helium atmosphere.

DATA TABLE NO. 35 SPECIFIC HEAT OF LANTHANUM OXIDE, La_2O_3
 [Temperature, T, K; Specific Heat, C_p , Cal g⁻¹K⁻¹]

T	C_p	T	C_p	T	C_p	T	C_p	T	C_p
383	8.533 x 10 ⁻²	104.46	4.140 x 10 ⁻²	124.92	4.861 x 10 ⁻²	5.30	1.8 x 10 ⁻⁵	34.48	8.318 x 10 ⁻¹
400	8.607	110.89	4.370	136.13	5.220*	6.38	4.30	38.81	1.028 x 10 ⁻²
450	8.786	117.22	4.598	146.13	5.521*	7.45	7.67	42.33	1.235
500	8.927	123.45	4.836	156.10	5.785*	8.39	8.39	46.93	1.474
550	9.044	129.89	5.026	166.13	6.043*	10.14	2.55	52.20	1.748
600	9.144	136.43	5.251	176.23	6.267*	11.51	3.898	57.54	2.020*
650	9.233	142.67	5.416*	187.09	6.494*	12.82	5.432	62.94	2.294*
700	9.313	148.65	5.586*	196.39	6.660*	14.07	7.213	68.40	2.558*
750	9.386	155.04	5.727*	206.99	6.853*	15.49	9.515	74.05	2.821*
800	9.455	166.03	5.995	215.84	6.997*	17.04	1.271 x 10 ⁻¹	80.14	3.108*
850	9.520	171.57	6.160*	226.23	7.151*	20.54	2.231	87.07	3.431
900	9.583	177.35	6.333	236.12	7.286*	22.42	2.876	83.51	3.257 x 10 ⁻² *
950	9.643	183.07	6.547*	245.72	7.399*	24.41	3.637	90.51	3.577*
1000	9.701	188.81	6.818	255.29	7.522*	49		97.82	3.869*
1050	9.757	201.66	7.097*	266.07	7.625*	50		105.38	4.164*
1100	9.812	215.03	7.388	275.99	7.725*	600		113.35	4.465*
1150	9.867*	221.90	7.693*	286.69	7.829*	700		121.18	4.748*
1171	9.889	228.54	7.160	296.34	7.924*	800		128.88	5.009*
		235.16	7.253*	398	8.556	900		137.29	5.279*
		241.61	7.338	40*	8.565	9.44	1.96	146.06	5.540*
		254.11	7.528*	50	8.912	10.65	3.04	154.72	5.776*
		260.07	7.577*	600	9.146	11.82	4.266	160.14	5.911*
16.91	1.538 x 10 ⁻³	272.36	7.693*	700	9.327	12.95	5.617	168.82	6.123*
21.27	3.275	279.79	7.758	800	9.480	14.26	7.458	177.41	6.316*
25.35	3.922	287.18	7.794*	900	9.616	15.70	9.344	186.16	6.501*
25.36	4.509	294.27	7.876	1000	9.742	17.29	1.329 x 10 ⁻³	195.26	6.679*
30.39	6.479	300.30	7.872	1100	9.861	18.99	1.756*	204.56	6.841*
33.12	7.833			1200	9.973	20.82	2.232*	213.89	6.995*
36.13	9.772			1300	1.009 x 10 ⁻¹	22.74	2.999	223.06	7.133*
39.73	1.155 x 10 ⁻²			1400	1.020	24.73	3.763	230.45	7.240*
43.95	1.337			1500	1.030	26.82	4.650	240.01	7.375*
48.52	1.556			1600	1.041	29.19	5.730		
53.73	1.899			1700	1.051	31.84	7.001		
58.49	2.146			1800	1.062	34.79	8.480*		
69.81	2.665					38.27	1.025 x 10 ⁻² *		
75.77	2.971								
82.12	3.215								
88.71	3.514								
92.13	3.662								
98.17	3.888								

* Not shown on Plot

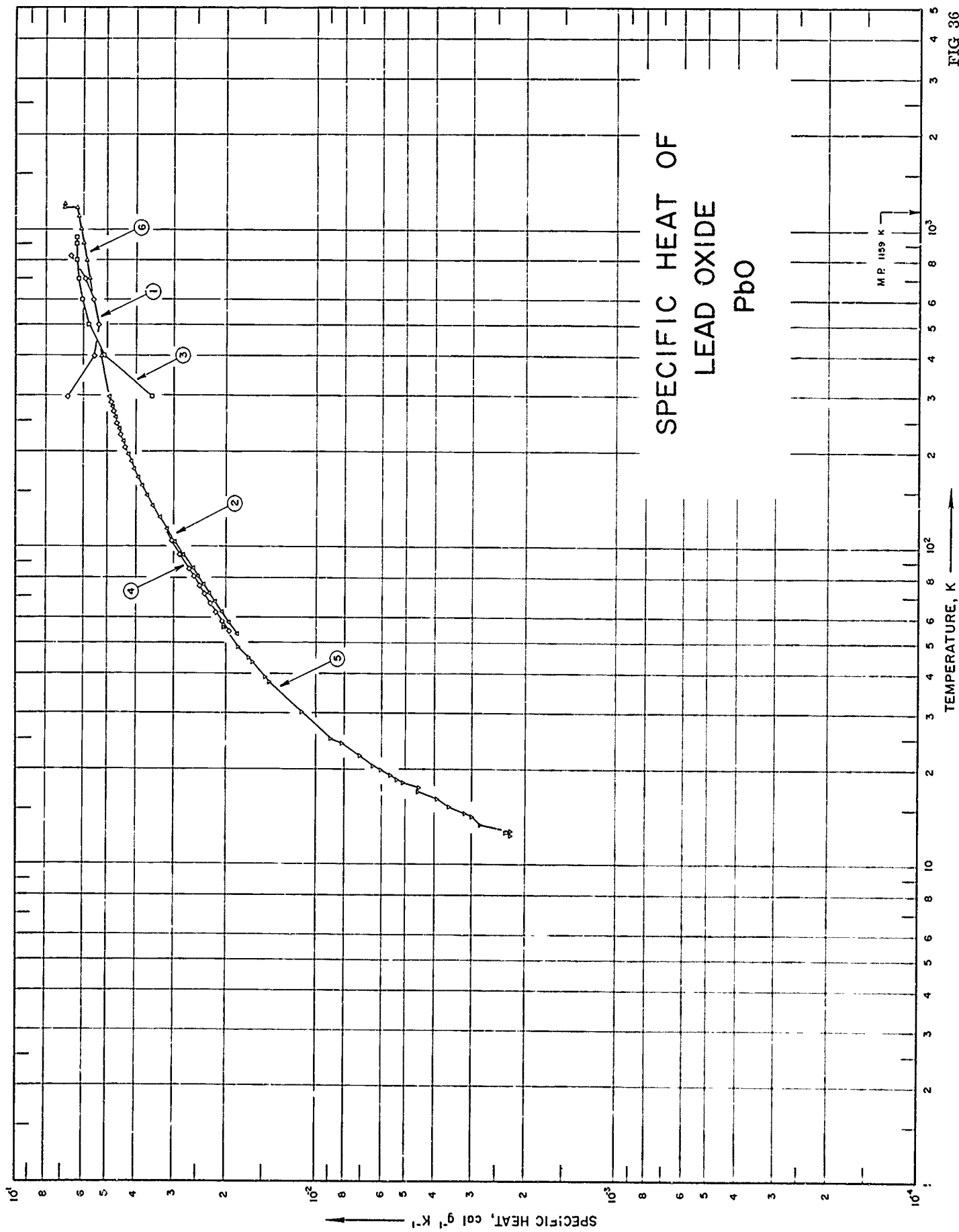

FIG 36

SPECIFICATION TABLE NO. 36 SPECIFIC HEAT OF LEAD OXIDE PbO

[For Data Reported in Figure and Table No. 36]

Curve No.	Ref. No.	Year	Temp. Range, K	Reported Error, %	Name and Specimen Designation	Composition (weight percent), Specifications and Remarks
1	85	1942	298-823		Red PbO	Red lead monoxide; dried in vacuum desiccator with potassium hydroxide and later for 2 wks with anhydrous magnesium perchlorate; heated at 140 C and later at 400 C.
2	86	1958	53-298		Red PbO	92.69 Pb; prepared by heating electrolytic lead dioxide in a vacuo at 430 - 480 C for 8 wks.
3	85	1942	298-943		Yellow PbO	Yellow lead monoxide; prepared by heating red monoxide at 600 C for 3 hrs.
4	86	1958	54-302		Yellow PbO	92.84 Pb; prepared by heating lead carbonate 560 - 580 C for 80 hrs, 725 C for 10 hrs; quench to room temperature.
5	87	1960	12-303		Yellow PbO	99.5 PbO; crystalline; dried at 150 C and 0.05 mm Hg; measured under 20 mm Hg helium.
6	88	1961	300-1200	0.01	Yellow PbO	

DATA TABLE NO. 36 SPECIFIC HEAT OF LEAD OXIDE, PbO
 (Temperature, T, K, Specific Heat, C_p , Cal $g^{-1} K^{-1}$)

T	C_p	T	C_p	T	C_p	T	C_p	T	C_p
CURVE 1		CURVE 3		CURVE 4		CURVE 5		CURVE 5 (cont.)	
298	6.767×10^{-2}	298	3.541×10^{-2}	12.47	2.24×10^{-1}	100.53	2.971×10^{-2}	229.96	4.503×10^{-2}
300	6.723	300	3.589	12.70	2.33	105.88	3.074	233.05	4.534
400	5.512	400	5.104	12.74	2.24	107.99	3.109	237.11	4.532
500	5.329	500	5.759	13.42	2.82	111.01	3.154	240.65	4.610
600	5.550	600	6.076	14.23	3.00	114.00	3.213	241.36	4.570
700	5.961	700	6.233	14.55	3.18	117.37	3.257	244.41	4.637
800	6.475	800	6.304	15.35	3.59	119.05	3.289	250.30	4.651
823	6.602	900	6.326	16.25	3.94	123.55	3.365	256.16	4.700
		943	6.326	17.03	4.570	125.17	3.387	266.17	4.740
				17.60	4.525	127.78	3.432	271.91	4.785
				18.31	5.108	130.36	3.463	274.95	4.790
				18.54	5.377	132.07	3.495	289.95	4.861
				18.92	5.466	135.02	3.540	294.47	4.784
				19.25	5.601	138.00	3.584	295.38	4.888
				19.48	5.645	139.87	3.625	298.39	4.893
				20.05	6.049	143.83	3.670	299.18	4.906
				20.61	6.093	145.99	3.701	299.48	4.920
				20.85	6.497	152.88	3.795	301.37	4.920
				21.09	6.676	154.97	3.822	302.71	4.924
				22.15	7.124	161.68	3.925		
				24.12	8.155	167.23	3.965		
				25.04	8.916	170.73	4.019		
				30.42	1.116×10^{-2}	172.95	4.050		
				37.83	1.443	178.20	4.073		
				39.11	1.488	186.42	4.171		
				47.86	1.640	189.09	4.180		
				48.00	1.689	193.05	4.225		
				48.84	1.828	193.43	4.248		
				49.99	1.855	197.26	4.35		
				56.63	2.034	200.14	4.283		
				58.73	2.083	201.15	4.301		
				61.70	2.151	204.28	4.328		
				64.37	2.209	204.59	4.333		
				71.03	2.366	208.62	4.364		
				74.67	2.446	209.14	4.368		
				77.76	2.505	213.94	4.386		
				81.09	2.594	217.86	4.422		
				84.00	2.657	218.99	4.422		
				86.53	2.715	223.69	4.463		
				89.36	2.782	225.77	4.480		
				97.44	2.817	229.76	4.539		

T	C_p	T	C_p
CURVE 2		CURVE 6	
53.40	1.835×10^{-2}	300	4.903×10^{-2}
58.07	1.951	400	5.210
62.71	2.064	500	5.418
67.26	2.173	600	5.586
71.67	2.279	800	5.736
76.13	2.379	900	5.876
81.30	2.490	1000	6.010
85.97	2.588	1100	6.268
94.64	2.768	1165.7	6.352
104.71	2.969	1165.7	6.960
114.78	3.154	1200	6.960
124.89	3.333		
135.91	3.513		
149.79	3.666		
155.84	3.805		
165.83	3.930		
176.34	4.050		
186.35	4.159		
195.99	4.247		
206.38	4.347		
216.27	4.425		
226.09	4.502		
236.73	4.574		
245.91	4.623		
256.39	4.691		
266.62	4.749		
276.58	4.798		
286.79	4.847		
296.27	4.901		
298.15	4.906		

Not shown on Plot

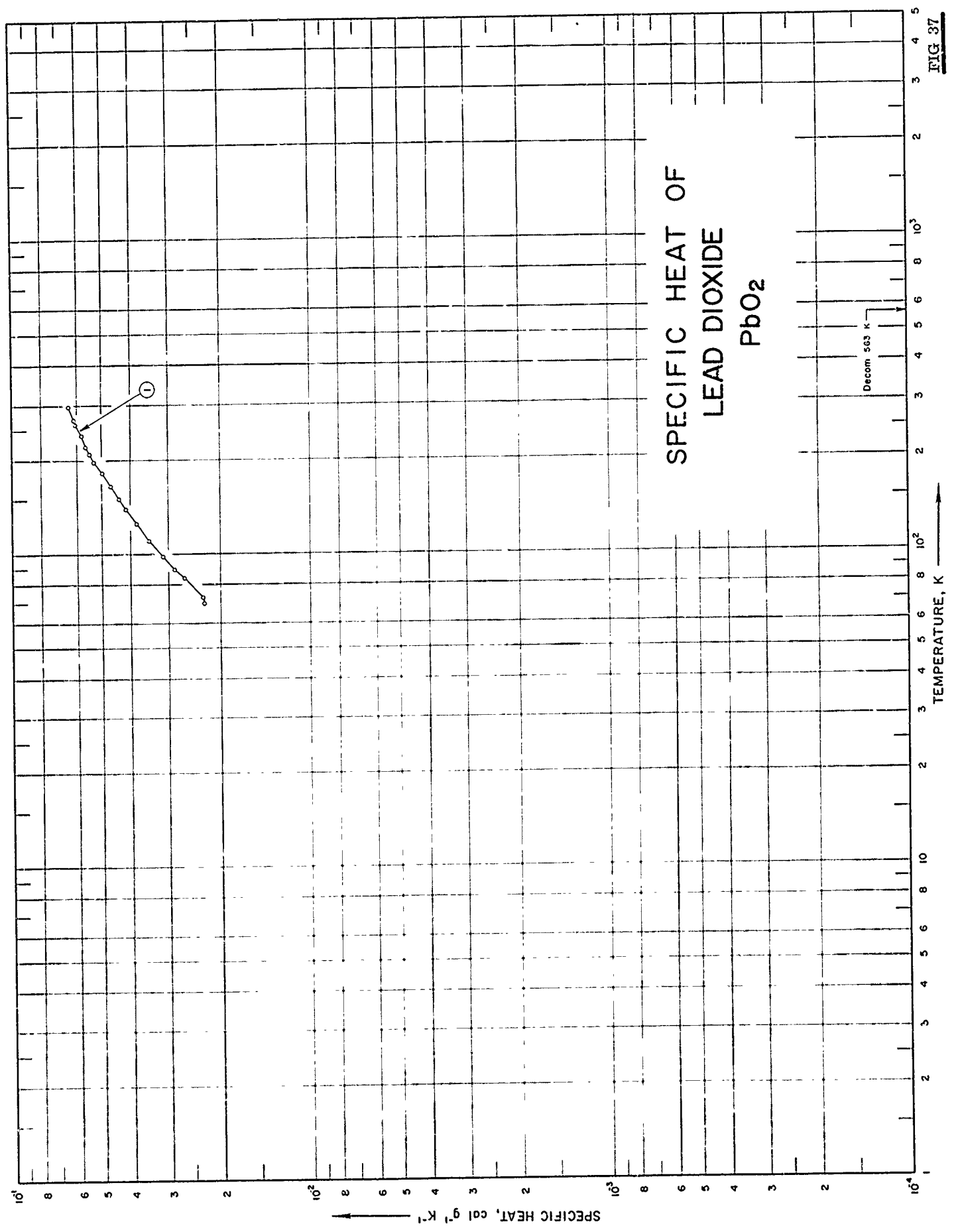

FIG 37

SPECIFICATION TABLE NO 37 SPECIFIC HEAT OF LEAD DIOXIDE PbO₂

[For Data Reported in Figure and Table No. 37]

Curve No.	Ref. No.	Year	Temp. Range, K	Reported Error, %	Name and Specimen Designation	Composition (weight percent), Specifications and Remarks
1	311	1929	70-297			99.5 theoretical amount of active oxygen; prepared by electrolysis of acid solution of lead nitrate.

DATA TABLE NO. 37 SPECIFIC HEAT OF LEAD DIOXIDE PbO_2
 [Temperature, T, K; Specific Heat, C_p , Cal $\text{g}^{-1} \text{K}^{-1}$]

T	C_p
	<u>CURVE 1</u>
69.9	2.270 x 10 ⁻²
73.1	2.378
84.5	2.653
89.8	2.870
98.9	3.129
111.6	3.485
126.0	3.829
140.7	4.168
151.8	4.373
166.9	4.695
183.4	4.992
198.4	5.318
212.9	5.481
227.9	5.644
242.0	5.832
261.6	6.104
270.5	6.200
298.1	6.446*
297.2	6.451

* Not shown on plot

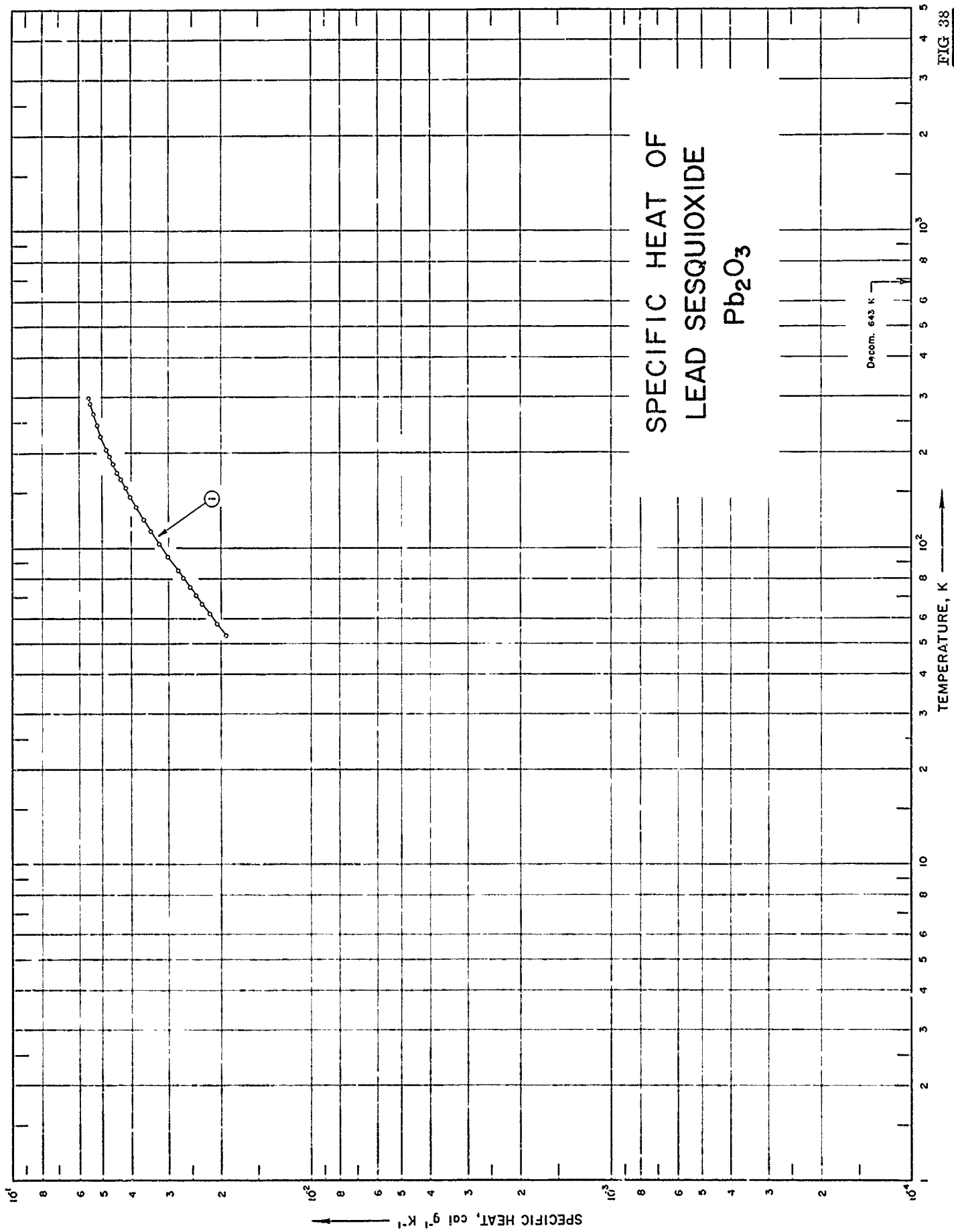

FIG 38

SPECIFICATION TABLE NO. 38 SPECIFIC HEAT OF LEAD SESQUIOXIDE Pb_2O_3

[For Data Reported in Figure and Table No. 38]

Curve No.	Ref. No.	Year	Temp. Range, K	Reported Error, %	Name and Specimen Designation	Composition (weight percent), Specifications and Remarks
1	86	1958	53-298			80.64 Pb.

DATA TABLE NO. 38 SPECIFIC HEAT OF LEAD SESQUIOXIDE, Pb_2O_3
 [Temperature, T, K; Specific Heat, C_p , Cal $g^{-1}K^{-1}$]

T	C_p
CURVE 1	
53.36	1.923×10^{-2}
58.06	2.060
62.66	2.188
67.03	2.314
71.50	2.431
75.95	2.545
81.00	2.677
85.48	2.783
94.96	3.008
104.75	3.227
114.88	3.438
124.78	3.635
136.53	3.854
145.90	4.018
155.87	4.180
166.02	4.329
175.85	4.459
186.19	4.595
196.05	4.710
206.42	4.829
216.45	4.931*
226.13	5.028*
235.97	5.112*
245.91	5.199*
256.50	5.285*
266.45	5.365*
276.38	5.426*
287.09	5.493*
296.56	5.558*
298.15	5.566

* Not shown on Plot

FIG. 39

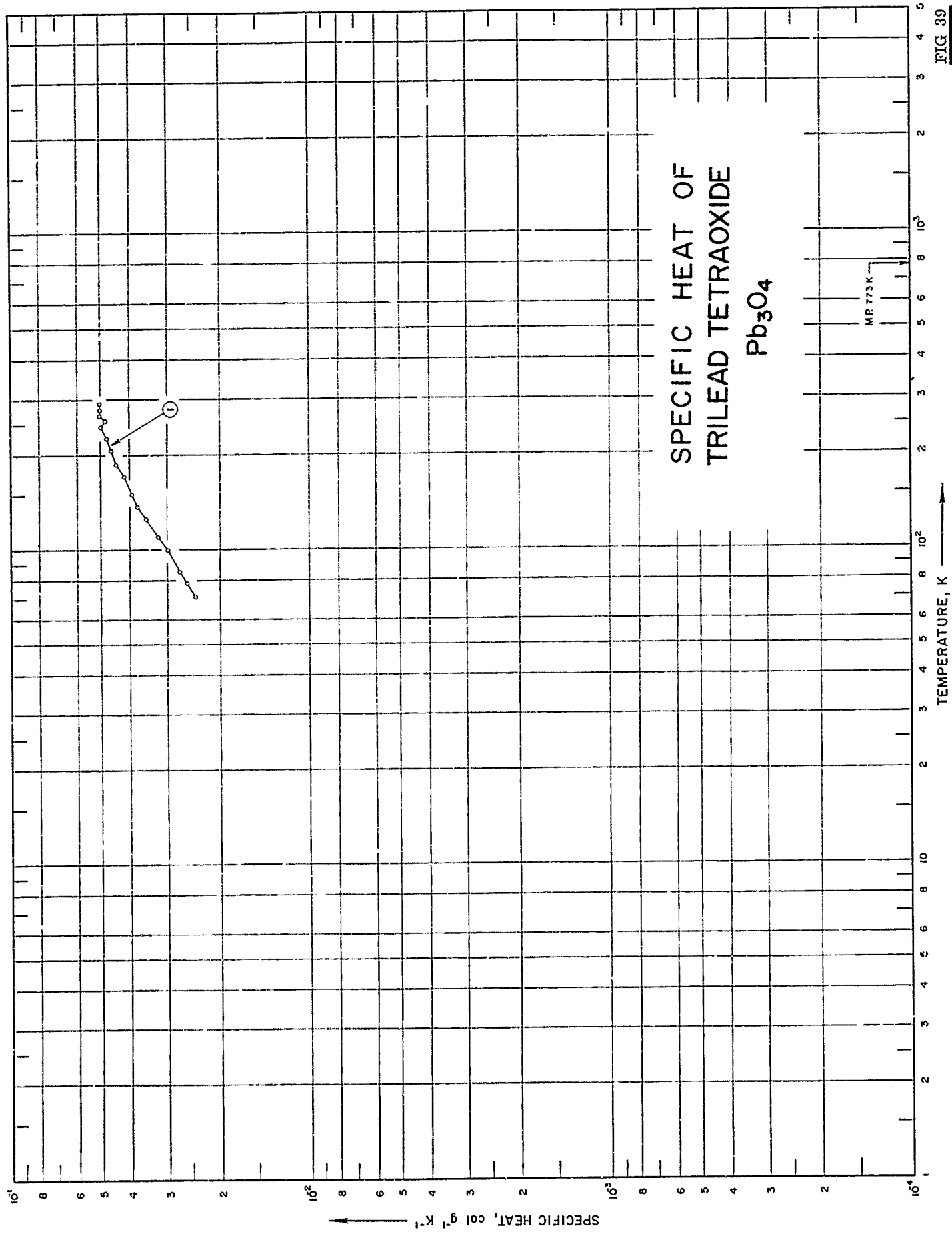

SPECIFICATION TABLE NO. 39 SPECIFIC HEAT OF TRILEAD TETRAOXIDE Pb_3O_4

[For Data Reported in Figure and Table No. 39]

Curve No.	Ref. No.	Year	Temp. Range, K	Reported Error, %	Name and Specimen Designation	Composition (weight percent), Specifications and Remarks
1	311	1929	71-292			97.0% of theoretical active oxygen, reduction by hydrogen showed 90.62 Pb (90.66 Pb theo.); prepared by decomposition of electrolytic lead dioxide in γ stirred bath of molten potassium nitrate at 460 C, then washed out and dried at 120 C.

DATA TABLE NO. 39 SPECIFIC HEAT OF TRILEAD TETRAOXIDE Pb_3O_4 [Temperature, T, K; Specific Heat, C_p , Cal $g^{-1} K^{-1}$]

T	C_p
71.5	2.429 x 10 ⁻²
78.5	2.599
85.6	2.744
100.1	2.997
111.7	3.257
127.1	3.543
138.6	3.766
151.3	3.950
172.1	4.196
187.4	4.425
208.8	4.618
227.1	4.774
247.1	4.994
259.8	4.813
266.2	5.023
278.2	5.013
292.6	5.026

CURVE 1

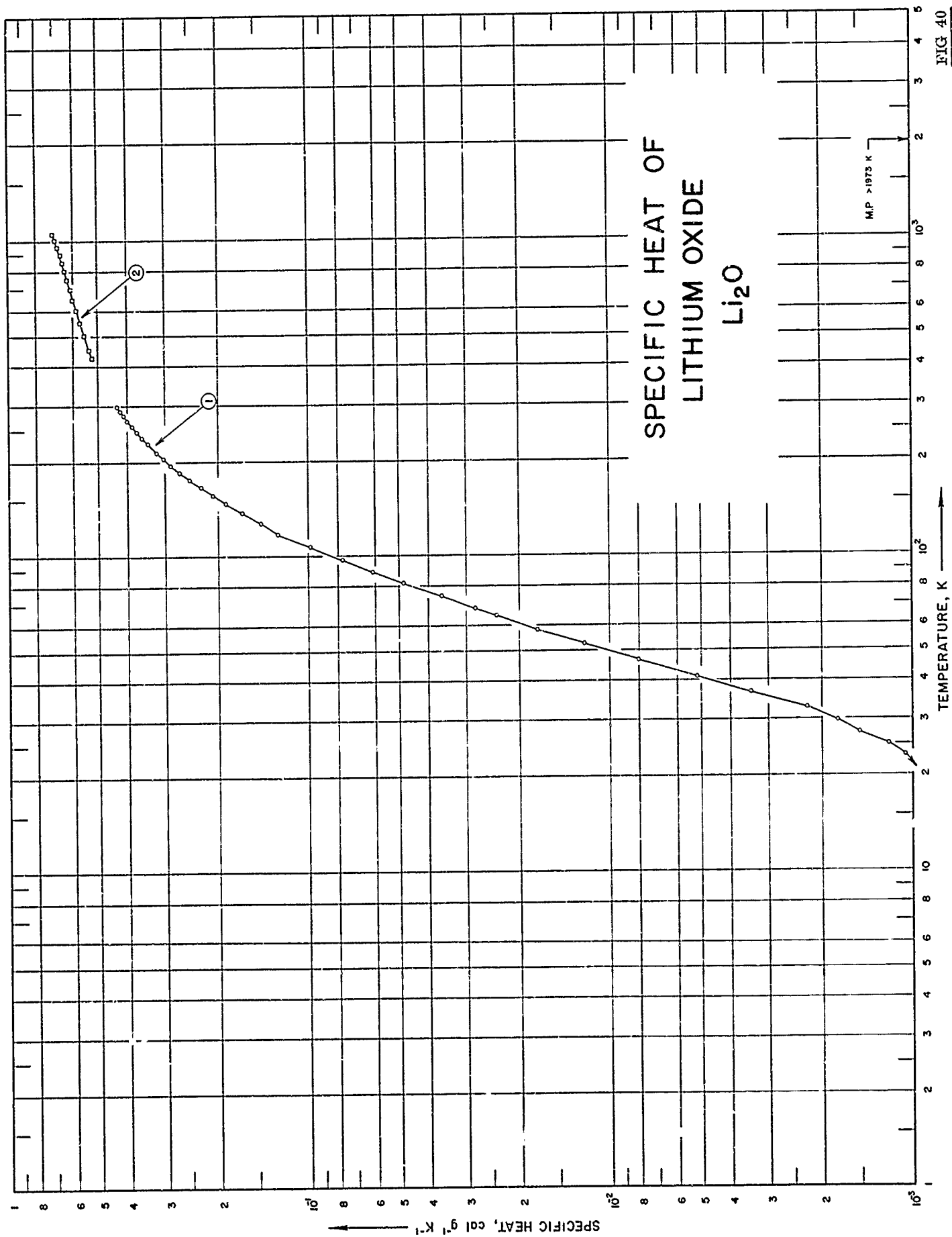

FIG 40

SPECIFICATION TABLE NO. 40 SPECIFIC HEAT OF LITHIUM OXIDE Li_2O

[For Data Reported in Figure and Table No. 40]

Curve No.	Ref. No.	Year	Temp. Range, K	Reported Error, %	Name and Specimen Designation	Composition (weight percent), Specifications and Remarks
1	89	1951	17-298			99.74 Li_2O and 0.26 CaO ; heat treated in nickel crucible at 1000 to 1300 C for 3 to 5 hrs; corrected for impurities.
2	90	1955	424-1050			99.2 Li_2O , 0.8 LiOH ; prepared from 99.9 Li_2O_2 .

DATA TABLE NO. 40 SPECIFIC HEAT OF LITHIUM OXIDE, Li_2O
 [Temperature, T, K, Specific Heat, C_p , Cal $\text{g}^{-1}\text{K}^{-1}$]

T	C_p		T	C_p
	CURVE 1	CURVE 2		
17.06	6.62×10^{-4} *		425	5.238×10^{-1}
20.68	9.64×10^{-4} *		450	5.357
23.93	1.06×10^{-3}		500	5.565
25.01	1.20		550	5.745
27.23	1.50		600	5.906
29.87	1.77		650	6.055
32.81	2.24		700	6.193
36.59	3.41		750	6.325
41.04	5.15		800	6.451
46.44	8.03		850	6.573
52.12	1.22×10^{-2}		900	6.691
58.05	1.75		950	6.807
64.51	2.39		1000	6.921
68.01	2.80		1050	7.034
74.26	3.63			
81.75	4.840			
88.90	6.124			
97.03	7.751			
107.30	9.913			
117.64	1.227×10^{-1}			
127.38	1.448			
137.49	1.675			
146.97	1.891			
155.73	2.082			
164.96	2.277			
174.90	2.482			
184.52	2.687			
194.17	2.877			
204.23	3.049			
208.11	3.113*			
214.43	3.207			
227.44	3.432			
238.53	3.590			
248.71	3.731			
258.38	3.863			
268.03	4.001			
279.01	4.121			
288.74	4.235			
298.89	4.330			

* Not shown on Plot

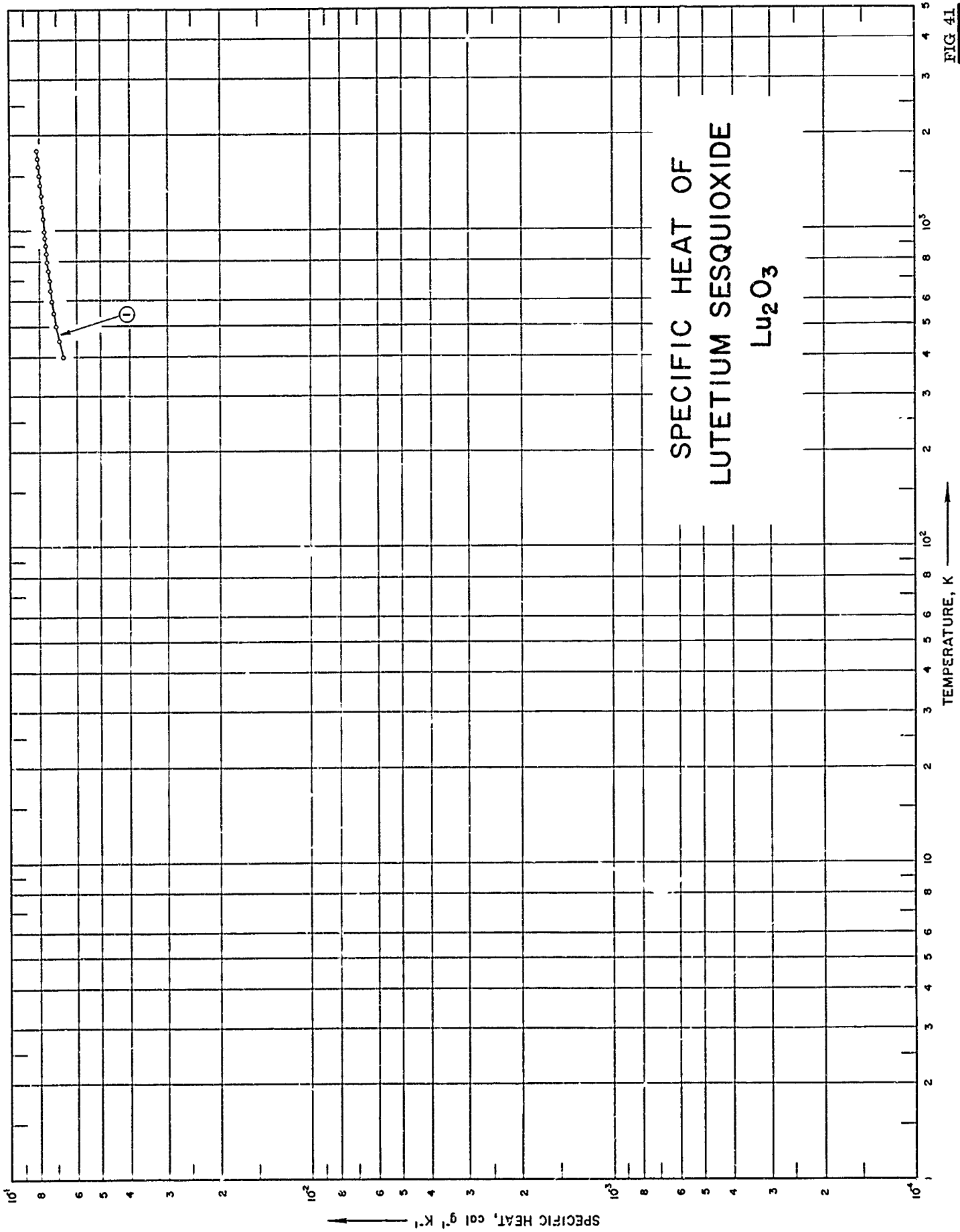

FIG. 41

SPECIFICATION TABLE NO. 41 SPECIFIC HEAT OF LUTETIUM SESQUIOXIDE Lu_2O_3

[For Data Reported in Figure and Table No. 41]

Curve No.	Ref. No.	Year	Temp. Range, K	Reported Error, %	Name and Specimen Designation	Composition (weight percent), Specifications and Remarks
1	53	1963	400-1800			99.9 Lu_2O_3 ; dried at 1100 - 1200 C.

DATA TABLE NO. 41 SPECIFIC HEAT OF LUTETIUM SESQUOXIDE, Lu_2O_3
 [Temperature, T, K; Specific Heat, C_p , Cal $\text{g}^{-1}\text{K}^{-1}$]

T	C_p
	6.642 x 10 ⁻²
400	6.857
450	7.018
500	7.142
550	7.242
600	7.325
650	7.395
700	7.456
750	7.509
800	7.558
850	7.602
900	7.643
950	7.681
1000	7.750
1100	7.814
1200	7.873
1300	7.930
1400	7.984
1500	8.036
1600	8.087
1700	8.136
1800	

CURVE 1.

Not shown on Plot

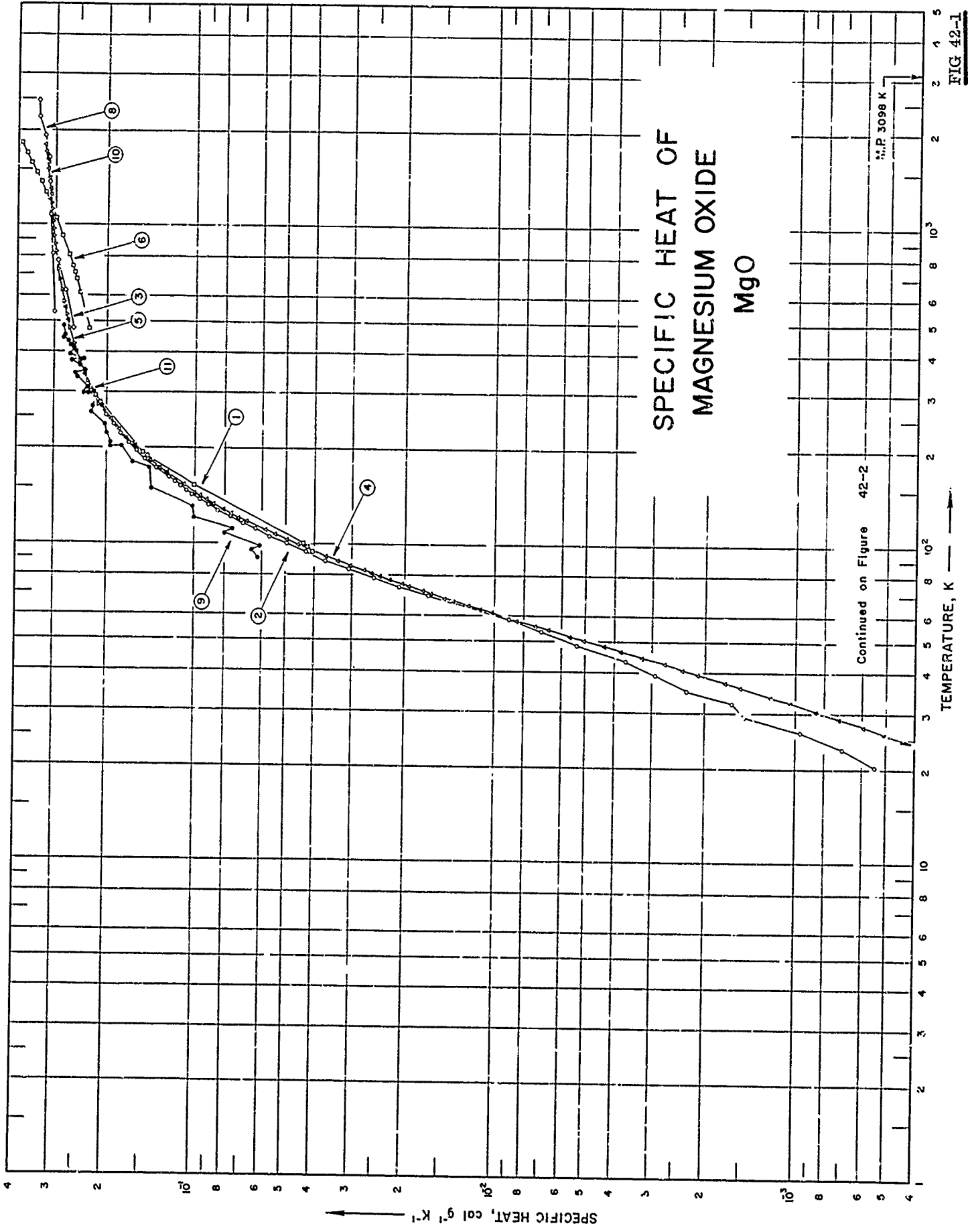
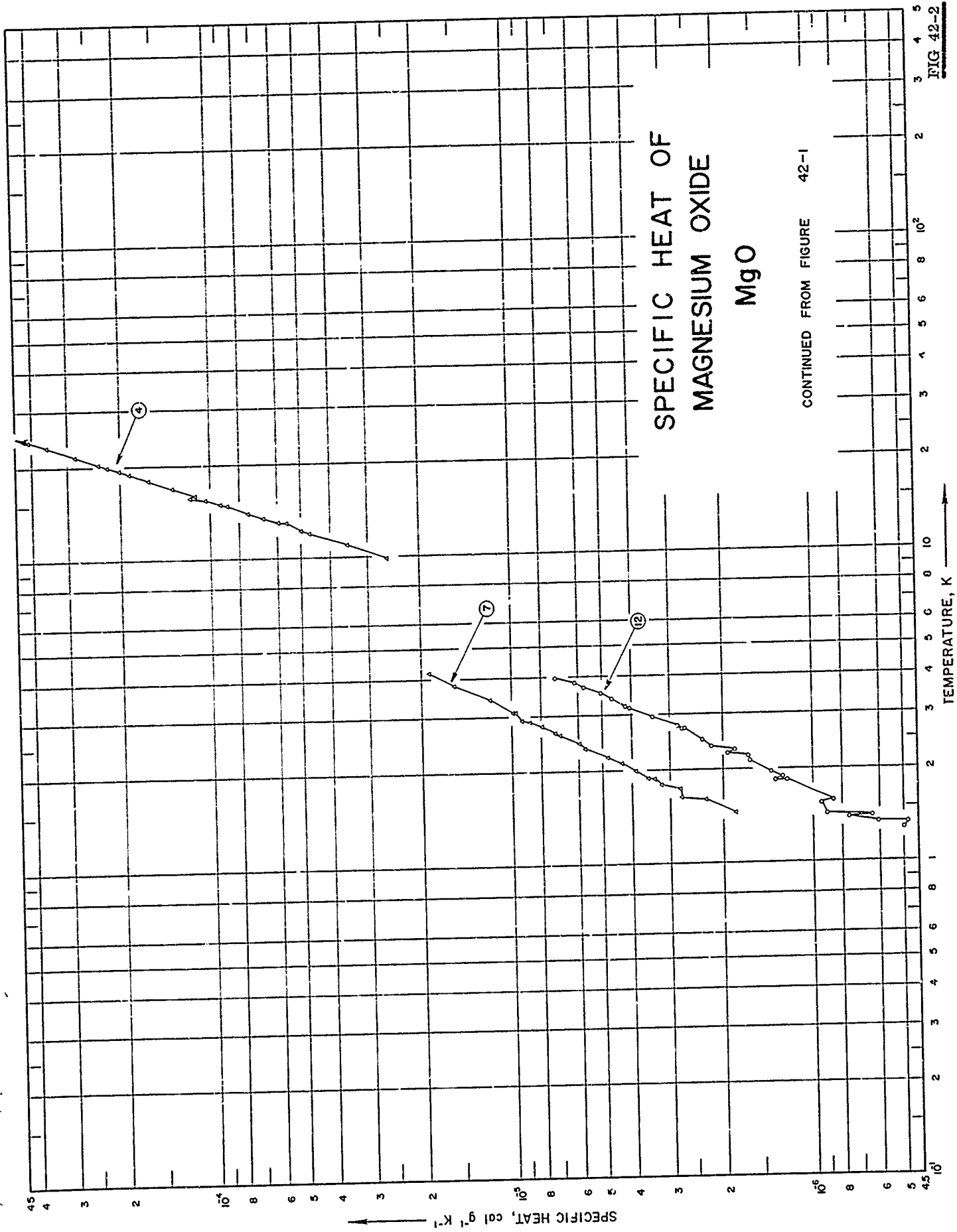

FIG 42-1



SPECIFIC HEAT OF
MAGNESIUM OXIDE
MgO

CONTINUED FROM FIGURE 42-1

SPECIFICATION TABLE NO. 42 SPECIFIC HEAT OF MAGNESIUM OXIDE MgO

[For Data Reported in Figure and Table No. 42]

Curve No.	Ref. No.	Year	Temp. Range, K	Reported Error, %	Name and Specimen Designation	Composition (weight percent), Specifications and Remarks
1	18	1926	94-291			High grade sample, fused magnesium oxide; supplied by Norton Co.
2	91	1937	20-300			95 MgO and ~5 Mg(OH) ₂ ; sample prepared by decomposing Mg(OH) ₂ under vacuum at 300 C and raised to 350 C at the end of decomposition; corrected for Mg(OH) ₂ .
3	92	1950	473-773		Magnesia	MgO.
4	93	1959	9-270	≤0.5		Single crystals; supplied by Norton Co.; heated in a vacuum at 150 C for 18 hrs; 10 ⁻⁶ mm Hg vacuum; helium atmosphere.
5	94	1960	273-1173	0.25		Bal. MgO, 0.025 Ca, 0.020 Fe, 0.009 Si, 0.008 Mn, 0.004 Al, <0.002 Na, <0.001 Ag, <0.001 Cr, and <0.001 Cu; single crystal; supplied by Norton Co.
6	95	1961	475-1811	3.0		>99.0 MgO, <0.5 Si, and <0.3 Mn; density 186 lb ft ⁻³ ; measured under helium atmosphere.
7	96	1962	1.3-4.2			Surface area of 166 m ² g ⁻¹ .
8	48	1962	533-2478	≤5.0		Before exposure: 59.4 Mg, 0.3 Fe, 0.3 Si, 0.2 Ca, and 0.1 Al; after exposure: 60.1 Mg and <0.05 C; sample supplied by Zirconium Corp. of America; crushed in hardened steel mortar to pass 100-mesh screen; pressed and sintered; before exposure: apparent density (ASTM method B311-58) 206 lb ft ⁻³ , true density (by immersion in xylene) 219 lb ft ⁻³ ; after exposure: apparent density 218 lb ft ⁻³ , true density 224 lb ft ⁻³ .
9	97	1962	90-481	≤5.0		MgO crystal, probably pure; Hanova liquid platinum was applied on the specimen's front surface for opaqueness and then painted with Parson's black for constant absorptivity; Hanova liquid platinum coatings were applied also on specimen's rear surface to obtain good conductive surface.
10	98	1963	298-1800	0.1		99.93 MgO, 0.04 Al ₂ O ₃ , and 0.01 SiO ₂ ; macro crystalline.
11	46	1963	298-1200	0.40		99.9 MgO, 0.025 Ca, 0.02 Fe, 0.009 Si, 0.008 Mn, 0.004 Al, <0.002 Na, <0.001 Ag, and <0.001 Cr, <0.001 Cu; fused.
12	96	1962	1.3-4			Surface area of 13.1 m ² g ⁻¹ .

DATA TABLE NO. 42 SPECIFIC HEAT OF MAGNESIUM OXIDE MgO [Temperature, T, K; Specific Heat, Cp, Cal g⁻¹K⁻¹]

T	Cp	T	Cp	T	Cp	T	Cp	T	Cp																														
CURVE 1																																							
94.1	4.02 x 10 ⁻²	166.76	1.287 x 10 ⁻¹ *	12.898	5.569 x 10 ⁻⁵	61.092	1.019 x 10 ⁻²	185.672	1.451 x 10 ⁻¹ *																														
97.9	4.42	172.75	1.353	12.906	5.907	62.701	1.117	189.309	1.486*																														
98.5	4.50*	178.83	1.419*	13.450	6.414	64.358	1.224	192.864	1.519*																														
100.0	4.70	184.81	1.481	13.905	7.442	66.494	1.368	196.348	1.550*																														
151.8	1.101 x 10 ⁻¹	190.51	1.534*	14.686	8.762	67.915	1.468	199.765	1.579*																														
188.4	1.452	195.81	1.582*	14.898	9.196	70.232	1.639	201.580	1.596																														
193.4	1.502	200.72	1.629*	15.471	1.042 x 10 ⁻⁴	71.463	1.734	204.901	1.623																														
275.3	2.090	205.76	1.664*	15.696	1.174	73.910	1.833	208.165	1.651*																														
278.0	2.137*	210.20	1.708*	15.896	1.126	74.978	2.022	211.376	1.677																														
288.3	2.170*	215.36	1.744*	16.019	1.124*	77.450	2.239	214.540	1.703																														
291.0	2.184	220.34	1.789	16.873	1.340	79.233	2.403	217.813	1.726*																														
CURVE 2																																							
20.34	5.46 x 10 ⁻⁴	225.06	1.819*	16.909	1.343*	80.845	2.563	221.192	1.753*																														
23.05	6.99	230.50	1.853*	17.921	1.601	82.406	2.716	224.522	1.778*																														
26.08	9.65	236.51	1.887	18.101	1.650*	85.494	3.029	226.412	1.791																														
29.16	1.48 x 10 ⁻³	242.55	1.932*	18.123	1.669*	88.488	3.344	229.672	1.815*																														
32.07	1.63	248.29	1.966*	18.851	1.861	91.417	3.675	232.890	1.838*																														
35.17	2.30	253.74	1.999	19.932	1.887*	92.952	3.724*	236.068	1.859*																														
39.15	2.93	258.99	2.033*	19.194	2.003	95.624	4.123*	239.351	1.881*																														
43.40	3.67	264.18	2.062*	19.937	2.210	99.306	4.542	242.736	1.903*																														
48.30	5.33	269.15	2.080*	20.263	2.354	102.902	4.969	246.081	1.925																														
52.52	6.97	274.10	2.105*	20.548	2.424*	106.484	5.403	249.388	1.938*																														
58.26	8.95	278.78	2.142*	21.500	2.833	110.069	5.837	250.938	1.952*																														
69.01	1.66 x 10 ⁻²	283.90	2.164*	23.104	3.513	113.639	6.254*	253.750	1.972*																														
73.62	2.07	289.19	2.196*	24.216	4.086	117.191	6.713	256.967	1.994*																														
78.46	2.535	294.25	2.232*	25.867	5.046	120.730	7.157	260.152	2.009*																														
83.53	3.073	300.68	2.254	27.247	5.954	124.263	7.596	263.308	2.028*																														
88.77	3.673	CURVE 3																																					
94.26	4.291	473	2.58 x 10 ⁻¹	30.419	8.511	129.700	8.253*	266.436	2.045*																														
99.94	4.950	623	2.76	32.362	1.034 x 10 ⁻³	133.280	8.717	269.793	2.063																														
105.51	5.623	773	2.92	33.692	1.201	136.904	9.159	CURVE 5																															
111.23	6.305	<table border="0"> <tr><td>273.15</td><td>2.110 x 10⁻¹</td></tr> <tr><td>323.15</td><td>2.309</td></tr> <tr><td>373.15</td><td>2.454</td></tr> <tr><td>423.15</td><td>2.565</td></tr> <tr><td>473.15</td><td>2.652</td></tr> <tr><td>523.15</td><td>2.723</td></tr> <tr><td>573.15</td><td>2.781</td></tr> <tr><td>623.15</td><td>2.830</td></tr> <tr><td>673.15</td><td>2.871</td></tr> <tr><td>723.15</td><td>2.907</td></tr> <tr><td>773.15</td><td>2.938*</td></tr> <tr><td>823.15</td><td>2.965</td></tr> <tr><td>873.15</td><td>2.989</td></tr> </table>									273.15	2.110 x 10 ⁻¹	323.15	2.309	373.15	2.454	423.15	2.565	473.15	2.652	523.15	2.723	573.15	2.781	623.15	2.830	673.15	2.871	723.15	2.907	773.15	2.938*	823.15	2.965	873.15	2.989			
273.15	2.110 x 10 ⁻¹																																						
323.15	2.309																																						
373.15	2.454																																						
423.15	2.565																																						
473.15	2.652																																						
523.15	2.723																																						
573.15	2.781																																						
623.15	2.830																																						
673.15	2.871																																						
723.15	2.907																																						
773.15	2.938*																																						
823.15	2.965																																						
873.15	2.989																																						
116.04	6.910	<table border="0"> <tr><td>1.612</td><td>2.743 x 10⁻⁶</td></tr> <tr><td>1.717</td><td>2.771</td></tr> <tr><td>1.850</td><td>3.379</td></tr> <tr><td>2.430</td><td>5.975</td></tr> <tr><td>2.628</td><td>7.190</td></tr> <tr><td>2.800</td><td>8.708</td></tr> <tr><td>3.084</td><td>9.721</td></tr> <tr><td>3.388</td><td>1.187 x 10⁻⁵</td></tr> <tr><td>3.785</td><td>1.557</td></tr> <tr><td>4.188</td><td>1.863</td></tr> </table>									1.612	2.743 x 10 ⁻⁶	1.717	2.771	1.850	3.379	2.430	5.975	2.628	7.190	2.800	8.708	3.084	9.721	3.388	1.187 x 10 ⁻⁵	3.785	1.557	4.188	1.863									
1.612	2.743 x 10 ⁻⁶																																						
1.717	2.771																																						
1.850	3.379																																						
2.430	5.975																																						
2.628	7.190																																						
2.800	8.708																																						
3.084	9.721																																						
3.388	1.187 x 10 ⁻⁵																																						
3.785	1.557																																						
4.188	1.863																																						
121.57	7.617										<table border="0"> <tr><td>1.612</td><td>2.743 x 10⁻⁶</td></tr> <tr><td>1.717</td><td>2.771</td></tr> <tr><td>1.850</td><td>3.379</td></tr> <tr><td>2.430</td><td>5.975</td></tr> <tr><td>2.628</td><td>7.190</td></tr> <tr><td>2.800</td><td>8.708</td></tr> <tr><td>3.084</td><td>9.721</td></tr> <tr><td>3.388</td><td>1.187 x 10⁻⁵</td></tr> <tr><td>3.785</td><td>1.557</td></tr> <tr><td>4.188</td><td>1.863</td></tr> </table>									1.612	2.743 x 10 ⁻⁶	1.717	2.771	1.850	3.379	2.430	5.975	2.628	7.190	2.800	8.708	3.084	9.721	3.388	1.187 x 10 ⁻⁵	3.785	1.557	4.188	1.863
1.612	2.743 x 10 ⁻⁶																																						
1.717	2.771																																						
1.850	3.379																																						
2.430	5.975																																						
2.628	7.190																																						
2.800	8.708																																						
3.084	9.721																																						
3.388	1.187 x 10 ⁻⁵																																						
3.785	1.557																																						
4.188	1.863																																						
127.56	8.452	<table border="0"> <tr><td>1.612</td><td>2.743 x 10⁻⁶</td></tr> <tr><td>1.717</td><td>2.771</td></tr> <tr><td>1.850</td><td>3.379</td></tr> <tr><td>2.430</td><td>5.975</td></tr> <tr><td>2.628</td><td>7.190</td></tr> <tr><td>2.800</td><td>8.708</td></tr> <tr><td>3.084</td><td>9.721</td></tr> <tr><td>3.388</td><td>1.187 x 10⁻⁵</td></tr> <tr><td>3.785</td><td>1.557</td></tr> <tr><td>4.188</td><td>1.863</td></tr> </table>																		1.612	2.743 x 10 ⁻⁶	1.717	2.771	1.850	3.379	2.430	5.975	2.628	7.190	2.800	8.708	3.084	9.721	3.388	1.187 x 10 ⁻⁵	3.785	1.557	4.188	1.863
1.612	2.743 x 10 ⁻⁶																																						
1.717	2.771																																						
1.850	3.379																																						
2.430	5.975																																						
2.628	7.190																																						
2.800	8.708																																						
3.084	9.721																																						
3.388	1.187 x 10 ⁻⁵																																						
3.785	1.557																																						
4.188	1.863																																						
132.60	9.065										<table border="0"> <tr><td>1.612</td><td>2.743 x 10⁻⁶</td></tr> <tr><td>1.717</td><td>2.771</td></tr> <tr><td>1.850</td><td>3.379</td></tr> <tr><td>2.430</td><td>5.975</td></tr> <tr><td>2.628</td><td>7.190</td></tr> <tr><td>2.800</td><td>8.708</td></tr> <tr><td>3.084</td><td>9.721</td></tr> <tr><td>3.388</td><td>1.187 x 10⁻⁵</td></tr> <tr><td>3.785</td><td>1.557</td></tr> <tr><td>4.188</td><td>1.863</td></tr> </table>									1.612	2.743 x 10 ⁻⁶	1.717	2.771	1.850	3.379	2.430	5.975	2.628	7.190	2.800	8.708	3.084	9.721	3.388	1.187 x 10 ⁻⁵	3.785	1.557	4.188	1.863
1.612	2.743 x 10 ⁻⁶																																						
1.717	2.771																																						
1.850	3.379																																						
2.430	5.975																																						
2.628	7.190																																						
2.800	8.708																																						
3.084	9.721																																						
3.388	1.187 x 10 ⁻⁵																																						
3.785	1.557																																						
4.188	1.863																																						
137.25	9.638	<table border="0"> <tr><td>1.612</td><td>2.743 x 10⁻⁶</td></tr> <tr><td>1.717</td><td>2.771</td></tr> <tr><td>1.850</td><td>3.379</td></tr> <tr><td>2.430</td><td>5.975</td></tr> <tr><td>2.628</td><td>7.190</td></tr> <tr><td>2.800</td><td>8.708</td></tr> <tr><td>3.084</td><td>9.721</td></tr> <tr><td>3.388</td><td>1.187 x 10⁻⁵</td></tr> <tr><td>3.785</td><td>1.557</td></tr> <tr><td>4.188</td><td>1.863</td></tr> </table>																		1.612	2.743 x 10 ⁻⁶	1.717	2.771	1.850	3.379	2.430	5.975	2.628	7.190	2.800	8.708	3.084	9.721	3.388	1.187 x 10 ⁻⁵	3.785	1.557	4.188	1.863
1.612	2.743 x 10 ⁻⁶																																						
1.717	2.771																																						
1.850	3.379																																						
2.430	5.975																																						
2.628	7.190																																						
2.800	8.708																																						
3.084	9.721																																						
3.388	1.187 x 10 ⁻⁵																																						
3.785	1.557																																						
4.188	1.863																																						
142.03	1.031 x 10 ⁻¹										<table border="0"> <tr><td>1.612</td><td>2.743 x 10⁻⁶</td></tr> <tr><td>1.717</td><td>2.771</td></tr> <tr><td>1.850</td><td>3.379</td></tr> <tr><td>2.430</td><td>5.975</td></tr> <tr><td>2.628</td><td>7.190</td></tr> <tr><td>2.800</td><td>8.708</td></tr> <tr><td>3.084</td><td>9.721</td></tr> <tr><td>3.388</td><td>1.187 x 10⁻⁵</td></tr> <tr><td>3.785</td><td>1.557</td></tr> <tr><td>4.188</td><td>1.863</td></tr> </table>									1.612	2.743 x 10 ⁻⁶	1.717	2.771	1.850	3.379	2.430	5.975	2.628	7.190	2.800	8.708	3.084	9.721	3.388	1.187 x 10 ⁻⁵	3.785	1.557	4.188	1.863
1.612	2.743 x 10 ⁻⁶																																						
1.717	2.771																																						
1.850	3.379																																						
2.430	5.975																																						
2.628	7.190																																						
2.800	8.708																																						
3.084	9.721																																						
3.388	1.187 x 10 ⁻⁵																																						
3.785	1.557																																						
4.188	1.863																																						
146.78	1.072	<table border="0"> <tr><td>1.612</td><td>2.743 x 10⁻⁶</td></tr> <tr><td>1.717</td><td>2.771</td></tr> <tr><td>1.850</td><td>3.379</td></tr> <tr><td>2.430</td><td>5.975</td></tr> <tr><td>2.628</td><td>7.190</td></tr> <tr><td>2.800</td><td>8.708</td></tr> <tr><td>3.084</td><td>9.721</td></tr> <tr><td>3.388</td><td>1.187 x 10⁻⁵</td></tr> <tr><td>3.785</td><td>1.557</td></tr> <tr><td>4.188</td><td>1.863</td></tr> </table>																		1.612	2.743 x 10 ⁻⁶	1.717	2.771	1.850	3.379	2.430	5.975	2.628	7.190	2.800	8.708	3.084	9.721	3.388	1.187 x 10 ⁻⁵	3.785	1.557	4.188	1.863
1.612	2.743 x 10 ⁻⁶																																						
1.717	2.771																																						
1.850	3.379																																						
2.430	5.975																																						
2.628	7.190																																						
2.800	8.708																																						
3.084	9.721																																						
3.388	1.187 x 10 ⁻⁵																																						
3.785	1.557																																						
4.188	1.863																																						
151.39	1.127										<table border="0"> <tr><td>1.612</td><td>2.743 x 10⁻⁶</td></tr> <tr><td>1.717</td><td>2.771</td></tr> <tr><td>1.850</td><td>3.379</td></tr> <tr><td>2.430</td><td>5.975</td></tr> <tr><td>2.628</td><td>7.190</td></tr> <tr><td>2.800</td><td>8.708</td></tr> <tr><td>3.084</td><td>9.721</td></tr> <tr><td>3.388</td><td>1.187 x 10⁻⁵</td></tr> <tr><td>3.785</td><td>1.557</td></tr> <tr><td>4.188</td><td>1.863</td></tr> </table>									1.612	2.743 x 10 ⁻⁶	1.717	2.771	1.850	3.379	2.430	5.975	2.628	7.190	2.800	8.708	3.084	9.721	3.388	1.187 x 10 ⁻⁵	3.785	1.557	4.188	1.863
1.612	2.743 x 10 ⁻⁶																																						
1.717	2.771																																						
1.850	3.379																																						
2.430	5.975																																						
2.628	7.190																																						
2.800	8.708																																						
3.084	9.721																																						
3.388	1.187 x 10 ⁻⁵																																						
3.785	1.557																																						
4.188	1.863																																						
156.19	1.170	<table border="0"> <tr><td>1.612</td><td>2.743 x 10⁻⁶</td></tr> <tr><td>1.717</td><td>2.771</td></tr> <tr><td>1.850</td><td>3.379</td></tr> <tr><td>2.430</td><td>5.975</td></tr> <tr><td>2.628</td><td>7.190</td></tr> <tr><td>2.800</td><td>8.708</td></tr> <tr><td>3.084</td><td>9.721</td></tr> <tr><td>3.388</td><td>1.187 x 10⁻⁵</td></tr> <tr><td>3.785</td><td>1.557</td></tr> <tr><td>4.188</td><td>1.863</td></tr> </table>																		1.612	2.743 x 10 ⁻⁶	1.717	2.771	1.850	3.379	2.430	5.975	2.628	7.190	2.800	8.708	3.084	9.721	3.388	1.187 x 10 ⁻⁵	3.785	1.557	4.188	1.863
1.612	2.743 x 10 ⁻⁶																																						
1.717	2.771																																						
1.850	3.379																																						
2.430	5.975																																						
2.628	7.190																																						
2.800	8.708																																						
3.084	9.721																																						
3.388	1.187 x 10 ⁻⁵																																						
3.785	1.557																																						
4.188	1.863																																						
161.39	1.233										<table border="0"> <tr><td>1.612</td><td>2.743 x 10⁻⁶</td></tr> <tr><td>1.717</td><td>2.771</td></tr> <tr><td>1.850</td><td>3.379</td></tr> <tr><td>2.430</td><td>5.975</td></tr> <tr><td>2.628</td><td>7.190</td></tr> <tr><td>2.800</td><td>8.708</td></tr> <tr><td>3.084</td><td>9.721</td></tr> <tr><td>3.388</td><td>1.187 x 10⁻⁵</td></tr> <tr><td>3.785</td><td>1.557</td></tr> <tr><td>4.188</td><td>1.863</td></tr> </table>									1.612	2.743 x 10 ⁻⁶	1.717	2.771	1.850	3.379	2.430	5.975	2.628	7.190	2.800	8.708	3.084	9.721	3.388	1.187 x 10 ⁻⁵	3.785	1.557	4.188	1.863
1.612	2.743 x 10 ⁻⁶																																						
1.717	2.771																																						
1.850	3.379																																						
2.430	5.975																																						
2.628	7.190																																						
2.800	8.708																																						
3.084	9.721																																						
3.388	1.187 x 10 ⁻⁵																																						
3.785	1.557																																						
4.188	1.863																																						
CURVE 4																																							
9.759	2.585 x 10 ⁻⁵	9.759	2.617*	44.504	3.232	155.549	1.337*	243.15	2.565																														
9.799	2.617*	9.844	2.659*	46.547	3.810	158.847	1.173*	243.15	2.565																														
10.849	3.463	48.208	4.329	162.244	4.329	162.244	1.212*	243.15	2.565																														
10.878	3.575*	50.287	5.053	165.739	5.053	165.739	1.249	243.15	2.565																														
10.914	3.587*	51.740	5.614	172.989	5.614	172.989	1.288*	243.15	2.565																														
11.892	4.617	55.670	7.313	175.409	7.313	175.409	1.325*	243.15	2.565																														
11.911	4.651*	57.902	8.429	178.719	8.429	178.719	1.384*	243.15	2.565																														
12.138	4.966	59.175	9.107*	182.142	9.107*	182.142	1.420*	243.15	2.565																														

* Not shown on plot

DATA TABLE NO. 42 (continued)

CURVE 7 (cont.)		CURVE 9 (cont.)		CURVE 10 (cont.)		CURVE 12	
T	C _p	T	C _p	T	C _p	T	C _p
Series 2							
1.431	1.810 x 10 ⁻⁶	258.15	2.24 x 10 ⁻¹	1250	3.0928 x 10 ⁻¹	Series 1	
1.587	2.276	269.15	2.22	1300	3.1079	1.315	4.825 x 10 ⁻⁷
1.707	2.849*	296.15	2.30	1350	3.1227*	1.371	7.587
1.774	3.191	296.15	2.35*	1400	3.1372	1.410	6.992
1.858	3.544	297.15	2.19*	1450	3.1515*	1.819	1.330 x 10 ⁻⁶
1.968	3.888	297.15	2.39	1500	3.1656*	1.932	1.374
2.091	4.319	301.15	2.40*	1550	3.1794*	Series 2	
2.180	4.800	302.15	2.22*	1600	3.1931	1.267	4.985 x 10 ⁻⁷
2.336	5.702	309.15	2.31	1650	3.2067*	1.335	6.058
3.586	6.924	332.15	2.50	1700	3.2202	1.396	6.342
2.753	7.943	341.15	2.54	1750	3.2335*	1.525	9.354
2.895	9.277	349.15	2.38	1800	3.2468	1.559	8.542
3.084	9.982	361.15	2.46	CURVE II			
CURVE 8							
533.15	3.00 x 10 ⁻¹	375.15	2.62	298.15	2.209 x 10 ⁻¹	1.819	1.222 x 10 ⁻⁶
810.93	3.05	379.15	2.40	300	2.217	1.853	1.254
1088.71	3.10	393.15	2.65	320	2.297*	2.099	1.617
1366.48	3.13	410.15	2.56	340	2.365	2.177	1.646
1644.26	3.15	419.15	2.64	360	2.427*	2.161	1.665*
1922.04	3.25	431.15	2.68	380	2.481*	2.282	1.809
2199.82	3.40	437.15	2.65*	400	2.528	2.664	2.736
2477.59	3.40	441.15	2.75	420	2.576*	2.724	2.813
CURVE 9							
90.15	6.2 x 10 ⁻²	481.15	2.78	440	2.607*	2.684	2.686*
95.15	6.5	490	2.2133 x 10 ⁻¹ *	460	2.641*	2.226	1.919
98.15	6.1	500	2.2229*	480	2.671*	2.341	2.170
108.15	8.0	550	2.4149*	500	2.699	2.458	2.324
111.15	7.5	550	2.5438*	550	2.759	2.674	2.666
120.15	1.01 x 10 ⁻¹	600	2.6361*	600	2.809*	2.916	3.398
149.15	1.40	650	2.7055*	650	2.852*	3.135	4.046
173.15	1.43	700	2.7600*	700	2.888	3.355	4.635
180.15	1.64	750	2.8044*	750	2.921*	3.504	5.077
201.15	1.78	800	2.8416*	800	2.950*	3.794	6.159
201.15	1.93	850	2.8736*	850	2.976*	2.971	3.420*
221.15	1.98	900	2.9019*	900	2.999*	3.176	4.198
237.15	2.02*	950	2.9271*	950	3.026*	3.411	4.683*
245.15	2.03*	1000	2.9502*	1000	3.046*	3.666	5.736
CURVE 10							
90.15	6.2 x 10 ⁻²	1050	2.9715*	1150	3.089*	3.923	7.155
95.15	6.5	1100	2.9913*	1200	3.102		
98.15	6.1	1000	3.0101*				
108.15	8.0	1050	3.0279*				
111.15	7.5	1100	3.0450*				
120.15	1.01 x 10 ⁻¹	1150	3.0614*				
149.15	1.40	1200	3.0774*				
173.15	1.43						
180.15	1.64						
201.15	1.78						
201.15	1.93						
221.15	1.98						
237.15	2.02*						
245.15	2.03*						

Not shown on plot

FIG 43

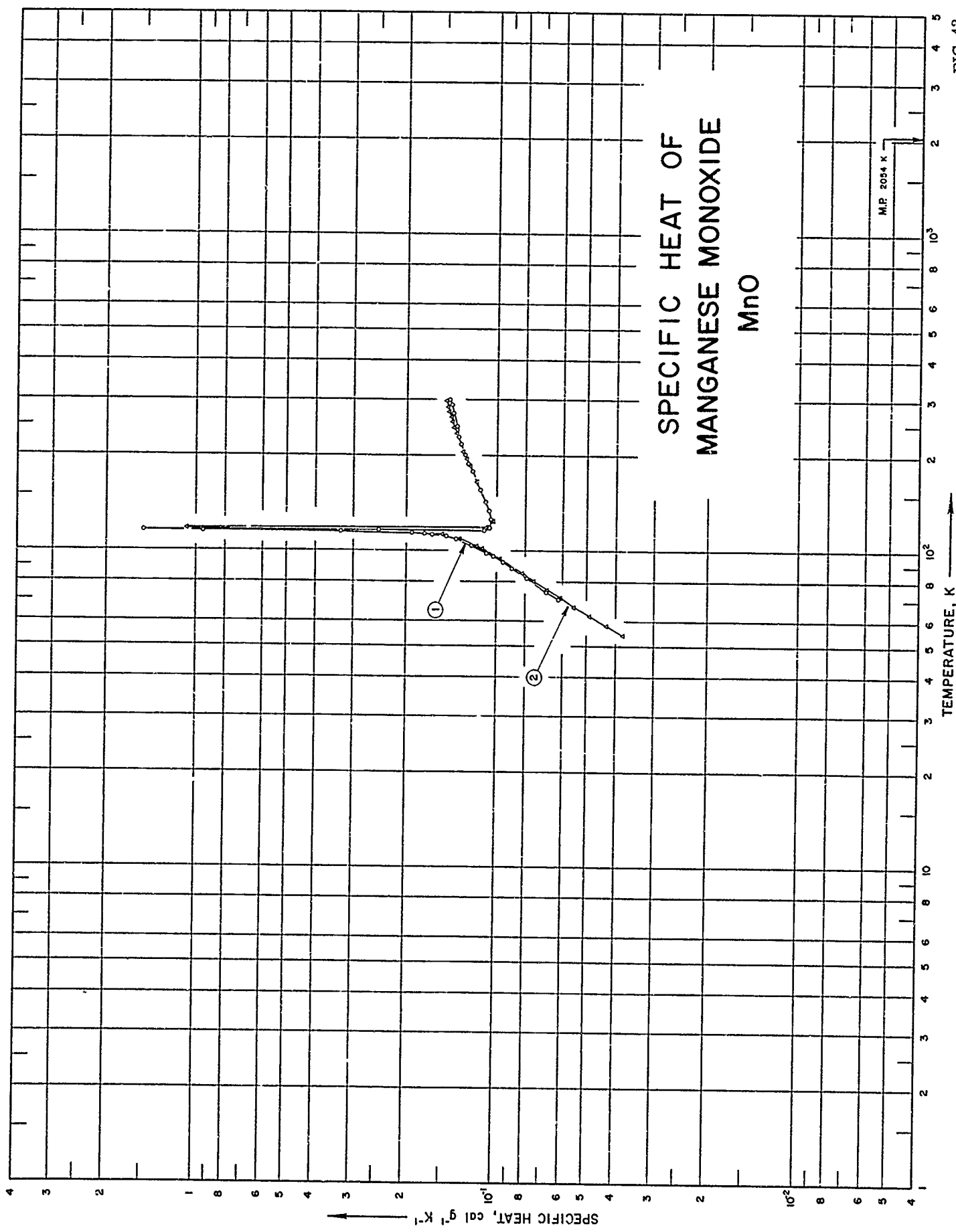

SPECIFICATION TABLE NO. 43 SPECIFIC HEAT OF MANGANESE MONOXIDE MnO

[For Data Reported in Figure and Table No. 43]

Curve No.	Ref. No.	Year	Temp. Range, K	Reported Error, %	Name and Specimen Designation	Composition (weight percent), Specifications and Remarks
1	99	1928	70-300			99.0 MnO; finely crystalline bright green product; prepared by reduction of amorphous Mn_3O_4 .
2	77	1951	54-298			99.85 MnO, 0.030 available oxygen, and 0.005 S; prepared from electrolytic manganese.

DATA TABLE NO. 43 SPECIFIC HEAT OF MANGANESE MONOXIDE MnO

[Temperature, T, K; Specific Heat, C_p , Cal g⁻¹ K⁻¹]

CURVE 1		CURVE 2	
T	C_p	T	C_p
70.4	6.240×10^{-2}	54.69	3.818×10^{-2}
74.3	6.864	58.42	4.320
82.1	7.965	62.45	4.903
88.5	8.949	66.80	5.534
92.1	9.582	71.27	6.174
96.5	1.038×10^{-1}	75.73	6.814
98.9	1.093	80.55	7.538
104.8	1.236*	85.21	8.250
108.8	1.362*	94.71	9.832
109.1	1.386*	102.10	1.126×10^{-1}
109.9	1.428*	103.99	1.172
111.0	1.485*	106.04	1.225*
112.0	1.548*	109.76	1.346
113.0	1.651	113.32	1.525
113.9	1.762	114.94	1.737*
114.8	1.943	116.25	1.906*
115.5	3.341	117.78	1.081×10^0
115.7	9.541	119.19	1.094×10^{-1}
115.9	1.5164×10^0	120.69	1.060*
116.2	3.378×10^{-1} *	121.41	1.053*
116.5	2.488	124.63	1.044
117.1	1.105	135.74	1.065*
118.5	1.066*	145.90	1.102*
118.9	1.061*	155.66	1.135*
126.8	1.053	165.74	1.174
128.6	1.055*	175.92	1.210*
134.5	1.070	185.99	1.244
143.3	1.099	196.02	1.275
155.6	1.145	206.26	1.302
178.0	1.216	216.20	1.331*
189.7	1.259	226.16	1.356*
203.3	1.293	236.00	1.378
217.5	1.334	245.69	1.400
229.7	1.352	256.05	1.418
247.1	1.371	265.94	1.437
289.1	1.432*	276.07	1.456
293.7	1.446*	286.28	1.472
300.2	1.452	296.40	1.485*
272.9	1.409	298.16	1.486

* Not shown on plot

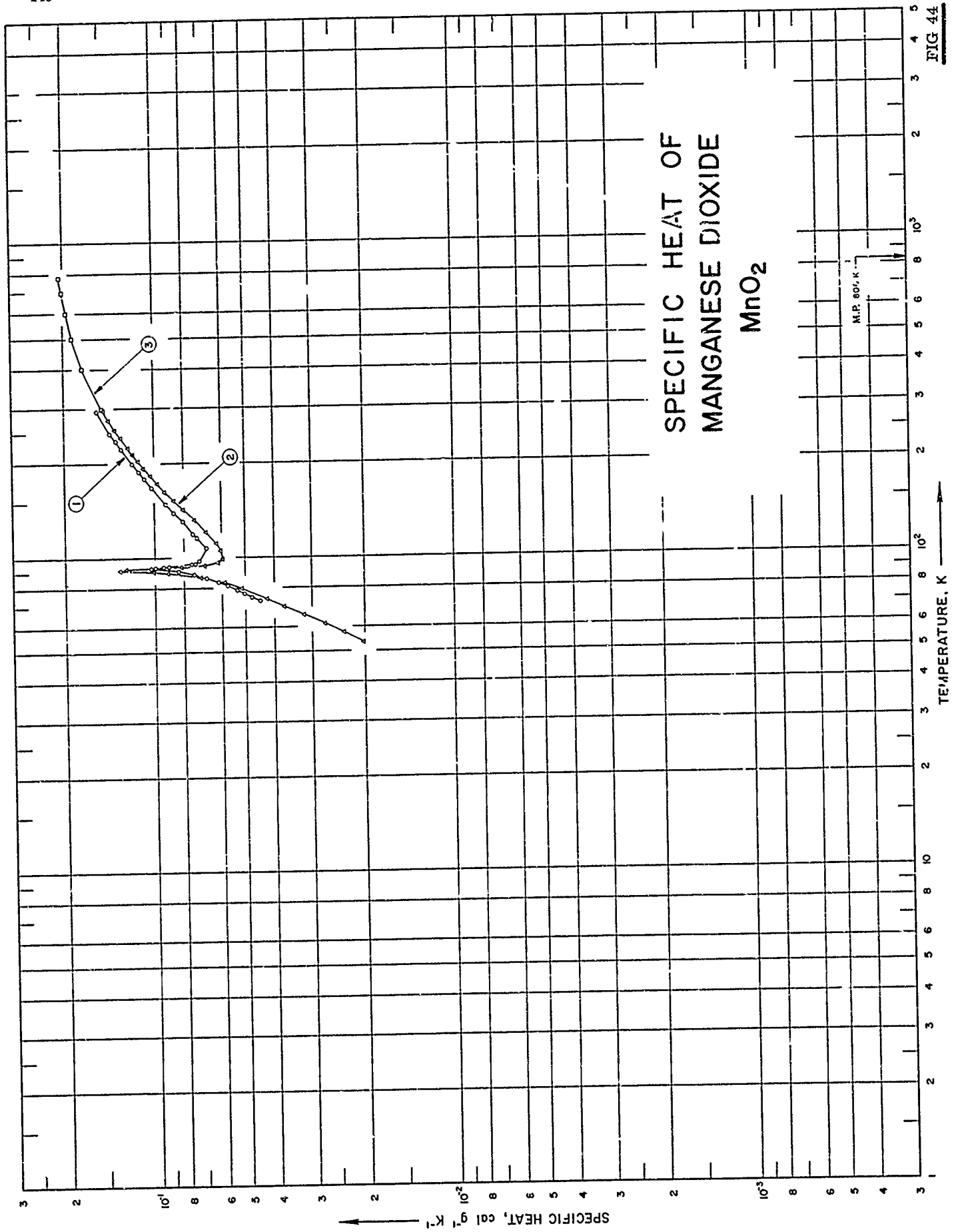

FIG 44

SPECIFICATION TABLE NO. 44 SPECIFIC HEAT OF MANGANESE DIOXIDE MnO_2

[For Data Reported in Figure and Table No. 44]

Curve No.	Ref. No.	Year	Temp. Range, K	Reported Error, %	Name and Specimen Designation	Composition (weight percent)	Specifications and Remarks
1	99	1928	72-293			99.6 MnO_2 ; prepared by heating the nitrate at 170 K.	
2	100	1943	53-294			99.88 MnO_2 ; pulverized and heated at 500 C in a stream of pure oxygen.	
3	101	1943	298-780			100.00 MnO_2 ; density 318.5 lb ft ⁻³ .	

DATA TABLE NO. 44 SPECIFIC HEAT OF MANGANESE DIOXIDE MnO₂
[Temperature, T, K; Specific Heat, C_p, Cal g⁻¹ K⁻¹]

CURVE 1		CURVE 2 (cont.)		CURVE 2 (cont.)		CURVE 3	
T	C _p	T	C _p	T	C _p	T	C _p
72.5	4.457 x 10 ⁻² *	73.9	4.257 x 10 ⁻²	225.4	1.232 x 10 ⁻² *	298.15	1.491 x 10 ⁻¹
72.8	4.487*	79.8	5.187*	235.9	1.275*	300	1.504*
74.6	4.732*	80.4	5.286*	241.1	1.296	400	1.743
74.8	4.774	83.3	5.891	245.7	1.316*	500	1.872
76.7	5.029	84.3	6.174*	252.5	1.341*	600	1.954
78.8	5.313	86.7	7.003*	256.4	1.354	700	2.015
81.1	5.744	87.6	7.470*	266.3	1.391*	780	2.056
83.4	6.177	89.4	9.028	276.1	1.423		
86.0	6.727	90.1	1.014 x 10 ⁻¹	285.8	1.450*		
88.3	7.419	91.4	1.313	294.7	1.479		
90.2	8.350	92.1	1.256				
90.3	8.446*	93.5	8.187 x 10 ⁻²				
91.8	9.788*	94.4	6.827				
92.5	1.039 x 10 ⁻¹	96.2	6.183				
92.9	9.958 x 10 ⁻²	97.4	6.058*				
93.2	9.969*	99.2	5.977*				
93.7	9.363	100.4	5.957*				
93.9	8.983	102.0	5.965*				
95.4	7.533	103.3	5.981*				
95.6	7.368	105.4	6.031				
97.4	7.12	106.7	6.071*				
107.2	6.73	111.1	6.254*				
115.4	7.229	112.5	6.318*				
119.7	7.492	120.7	6.747				
130.2	8.058	122.2	6.833*				
139.6	8.619	132.0	7.399				
148.8	9.197	132.9	7.447*				
165.9	1.020 x 10 ⁻¹	142.6	8.020				
179.3	1.089	143.4	8.077*				
188.7	1.135	152.5	8.605				
199.5	1.190	153.4	8.653*				
221.9	1.293	163.3	9.219*				
236.6	1.345	164.1	9.270*				
249.6	1.402	173.6	9.779				
292.6	1.564*	174.3	9.824*				
293.8	1.566	183.9	1.034				
		184.5	1.037*				
		194.4	1.089				
		195.0	1.093*				
		204.6	1.137*				
		205.2	1.141*				
		214.7	1.184*				
		215.3	1.187*				
		224.8	1.227				

CURVE 2

53.5	2.017 x 10 ⁻²
57.3	2.349
61.1	2.715
65.5	3.199
69.8	3.704

* Not shown on plot

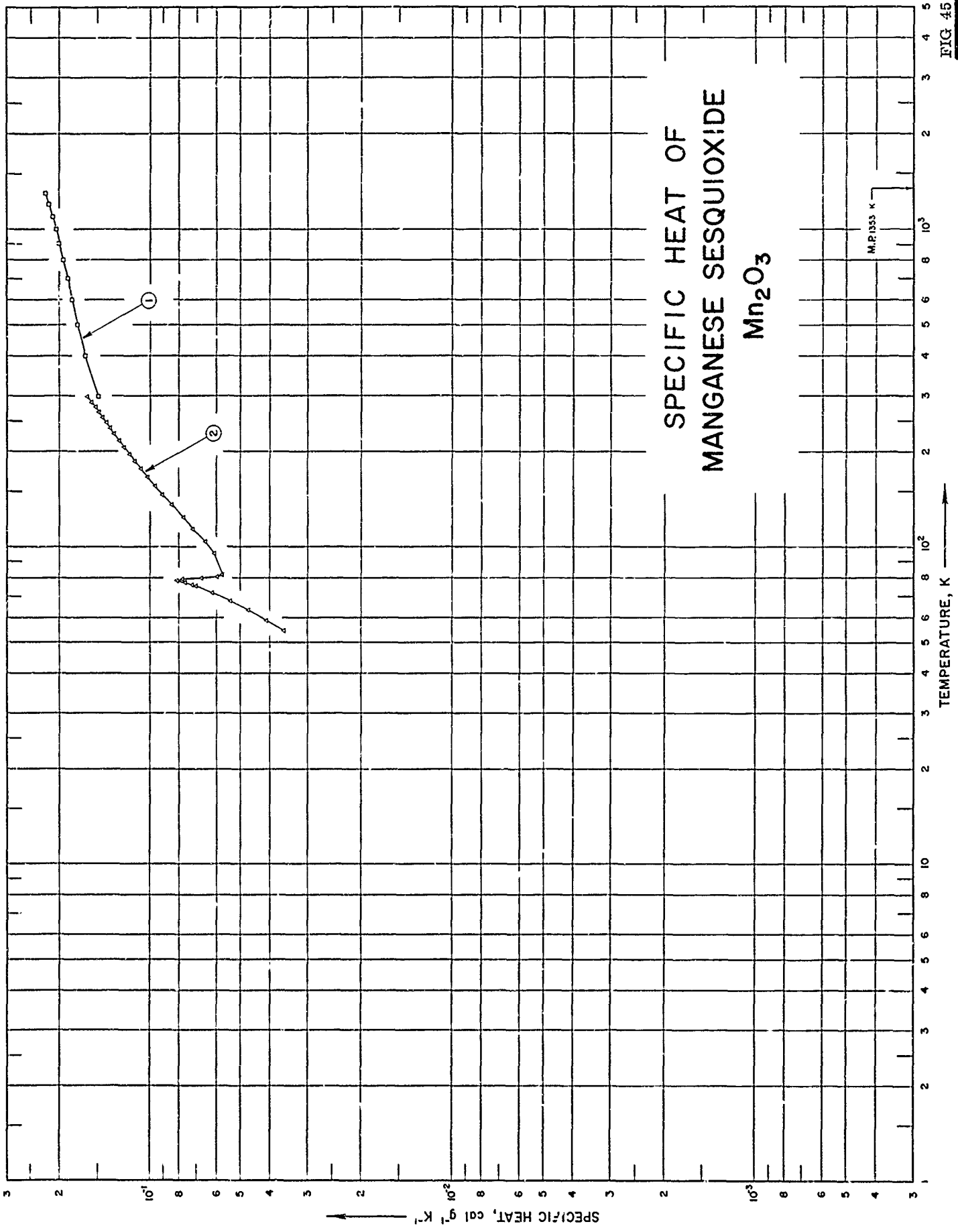

SPECIFICATION TABLE NO. 45 SPECIFIC HEAT OF MANGANESE SESQUIOXIDE Mn_2O_3

[For Data Reported in Figure and Table No. 45]

Curve No.	Ref. No.	Year	Temp. Range, K	Reported Error, %	Name and Specimen Designation	Composition (weight percent), Specifications and Remarks
1	102	1954	298-1300			Mn_2O_3 , 69.64 Mn, and 10.13 O_2 .
2	103	1954	54-298			63.64 Mn, 10.13 O_2 (theoretical 69.59 and 10.14).

DATA TABLE NO. 45 SPECIFIC HEAT OF MANGANESE SESQUIOXIDE Mn_2O_3
 [Temperature, T, K; Specific Heat, C_p , Cal g⁻¹ K⁻¹]

T	C_p	
	CURVE 1	CURVE 2 (cont.)
298.15	1.495×10^{-1}	1.323×10^{-1}
300	1.498*	1.359
400	1.651	1.397
500	1.750	1.442
600	1.828	1.491
700	1.896	1.530
800	1.959	1.581
900	2.019	1.621*
1000	2.077	1.630
1100	2.134	
1200	2.189	
1300	2.245	

CURVE 2

T	C_p	
	CURVE 1	CURVE 2
54.39	3.596×10^{-2}	
56.81	4.114	
63.23	4.736	
67.51	5.417	
71.77	6.218	
75.32	7.051	
75.94	7.272	
77.28	7.652	
78.28	8.121	
79.33	7.804	
79.98	6.759	
80.39	5.997	
81.92	5.784	
83.68	5.737*	
84.27	5.734*	
95.17	6.136	
104.60	6.582	
114.70	7.203	
124.51	7.798	
135.88	8.489	
146.36	9.109	
155.68	9.648	
166.07	1.023×10^{-1}	
176.08	1.078	
185.97	1.129	
196.09	1.177	
206.31	1.225	
216.43	1.270	

* Not shown on plot.

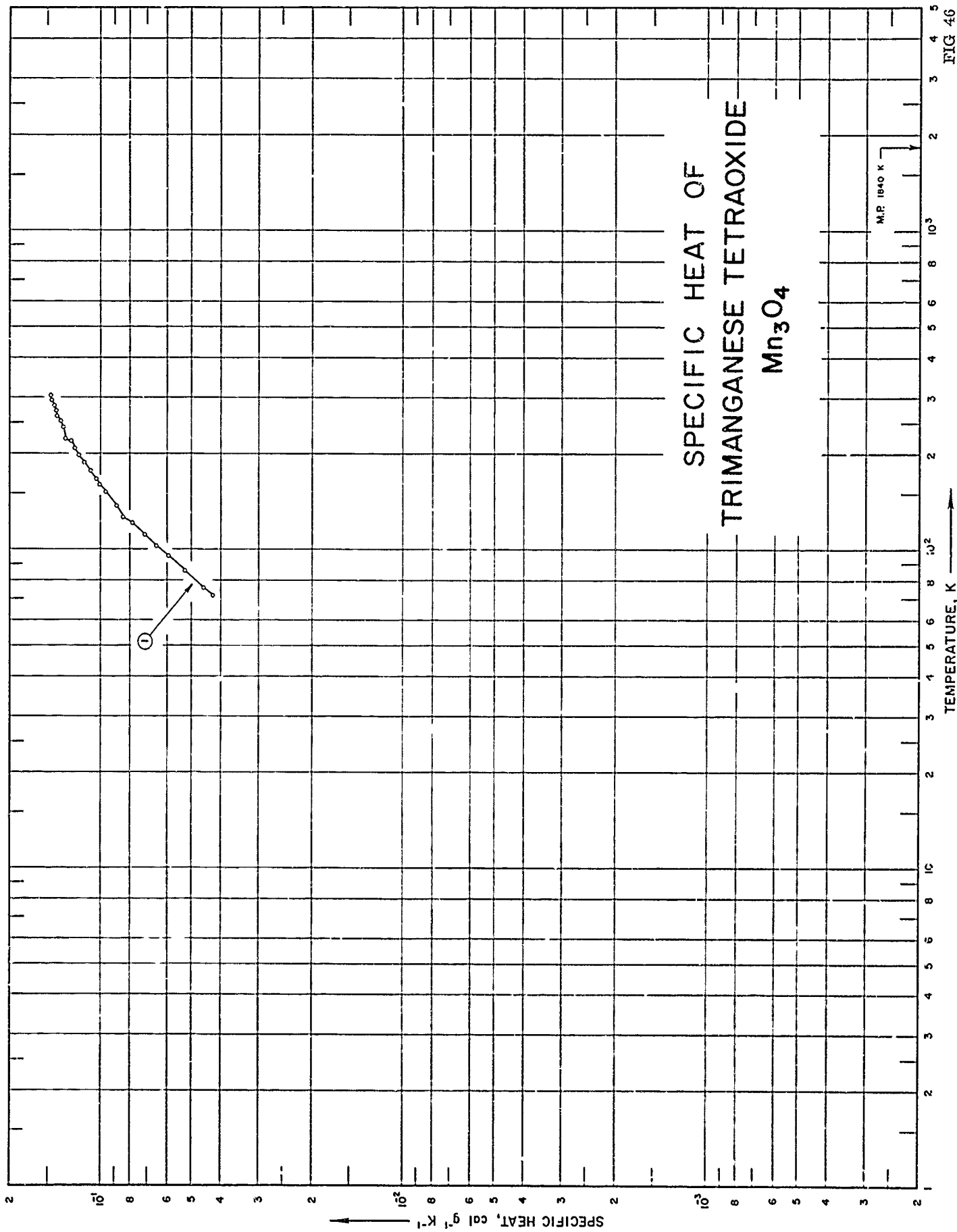

FIG 46

SPECIFICATION TABLE NO. 46 SPECIFIC HEAT OF TRIMANGANESE TETRAOXIDE Mn_3O_4

[For Data Reported in Figure and Table No. 46]

Curve No.	Ref. No.	Year	Temp. Range, K	Reported Error, %	Name and Specimen Designation	Composition (weight percent), Specifications and Remarks
1	99	1928	72-305			Finely crystalline; prepared from C. P. grade MnS .

DATA TABLE NO. 46 SPECIFIC HEAT OF TRIMANGANESE TETRAOXIDE Mn_3O_4
 [Temperature, T, K; Specific Heat, C_p , Cal $g^{-1} K^{-1}$]

T	C_p
	<u>CURVE 1</u>
72.2	4.250×10^{-2}
76.0	4.571
85.5	5.292
95.6	5.978
103.6	6.564
111.9	7.189
121.5	7.875
127.8	8.413
138.2	8.867
151.9	9.675
160.0	1.009×10^{-1}
167.4	1.047
177.6	1.097
188.0	1.148
199.1	1.195
200.4	1.196
209.4	1.234
220.0	1.256
223.2	1.318
241.4	1.341
252.5	1.367
263.1	1.401
271.5	1.418
283.4	1.432
295.3	1.457
305.2	1.462

*Not shown on plot

FIG 47

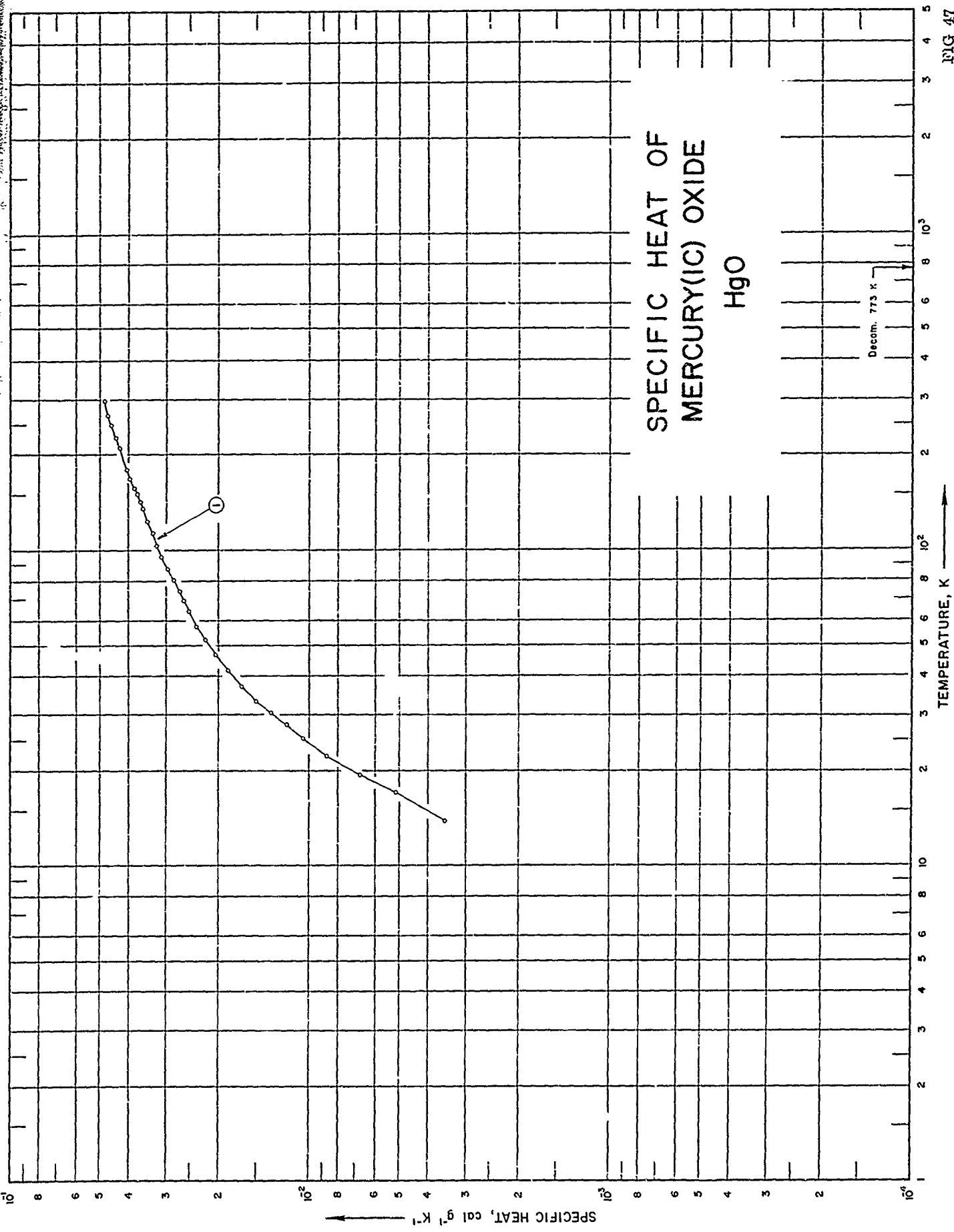

SPECIFICATION TABLE NO. 47 SPECIFIC HEAT OF MERCURY (IC) OXIDE HgO

[For Data Reported in Figure and Table No. 47]

Curve No.	Ref. No.	Year	Temp. Range, K	Reported Error, %	Name and Specimen Designation	Composition (weight percent), Specifications and Remarks
1	105	1953	15-298	≤0.5		Red modification, 0.020 insol. HCl, 0.010 nonvolatile matter, 0.001 Cl ₂ , 0.004 Fe, 0.005 SO ₄ , and 0.003 total N ₂ .

DATA TABLE NO. 47 SPECIFIC HEAT OF MERCURY (IC) OXIDE HgO
 [Temperature, T, K; Specific Heat, C_p , Cal g⁻¹ K⁻¹]

T	C_p
CURVE 1	
14.89	3.509×10^{-3}
17.06	5.106
19.45	6.759
22.33	8.702
25.41	1.051×10^{-2}
28.10	1.192
30.69	1.346
32.49	1.500
37.24	1.676
41.78	1.867
46.96	2.047
52.24	2.210
57.58	2.380
58.36	2.374*
64.59	2.513
69.17	2.610
74.56	2.700
80.84	2.840
87.52	2.962
95.56	3.111
104.34	3.229
114.42	3.331
124.94	1.464
136.03	3.594
142.70	3.667*
147.34	3.721*
150.84	3.734
158.15	3.850
169.51	3.958
180.87	4.055
210.58	4.295
216.19	4.330*
227.55	4.418
240.44	4.493
240.62	4.498
250.73	4.599
250.86	4.579*
262.10	4.680*
268.37	4.703
278.18	4.758*
291.23	4.824*
298.24	4.840

* Not shown on plot

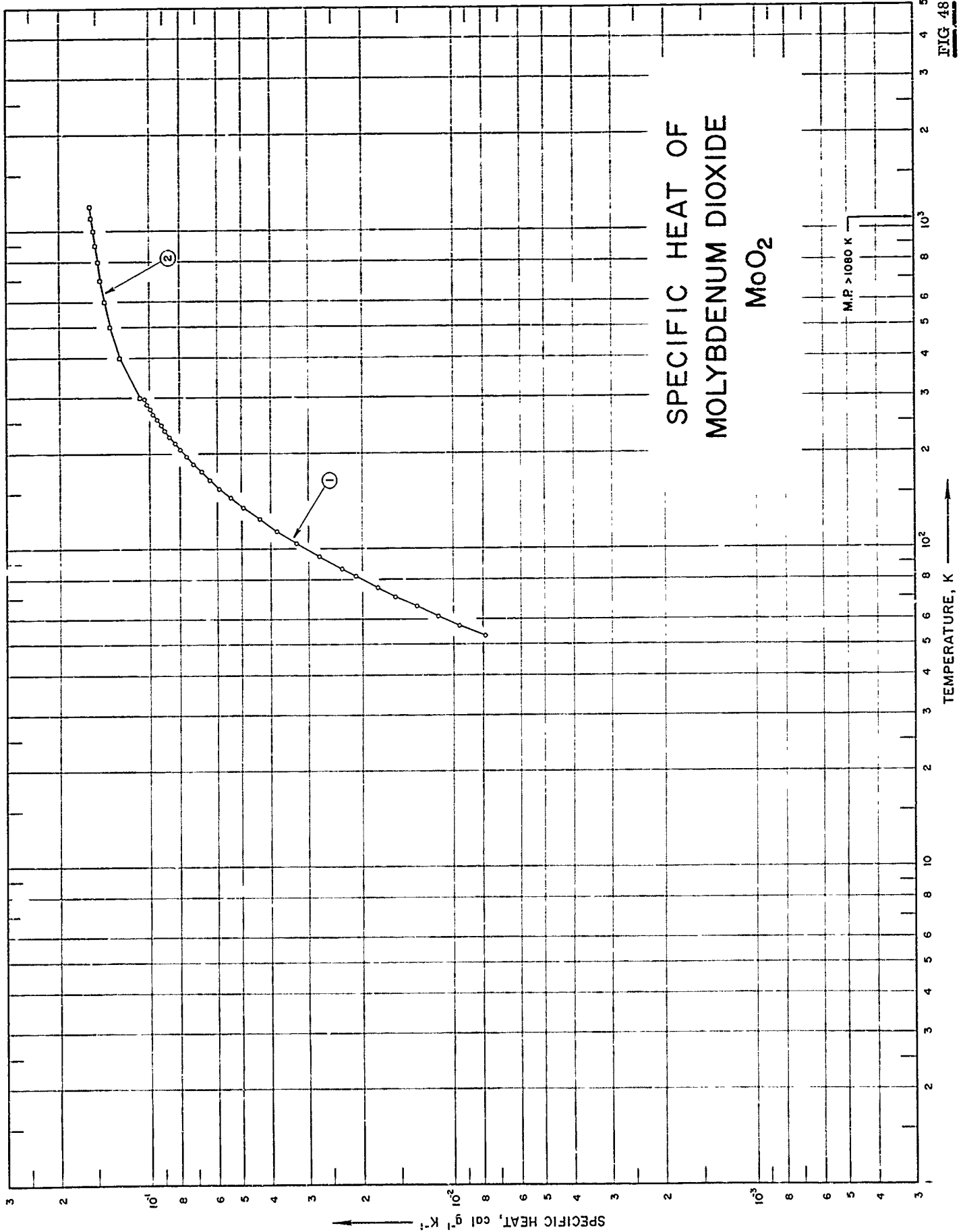

FIG 48

SPECIFICATION TABLE NO. 48 SPECIFIC HEAT OF MOLYBDENUM DIOXIDE MoO₂

[For Data Reported in Figure and Table No. 48]

Curve No.	Ref. No.	Year	Temp. Range, K	Reported Error, %	Name and Specimen Designation	Composition (weight percent), Specifications and Remarks
1	75	1958	53-296			74.99 Mo.
2	54	1965	300-1200	1.8		Supplied by Climax Molybdenum Co.

DATA TABLE NO. 48 SPECIFIC HEAT OF MOLYBDENUM DIOXIDE MoO_2
 [Temperature, T, K; Specific Heat, C_p , Cal $\text{g}^{-1} \text{K}^{-1}$]

T	C_p
<u>CURVE 1</u>	
53.31	7.871×10^{-3}
57.41	9.544
61.61	1.126×10^{-2}
66.05	1.321
70.92	1.552
75.82	1.778
82.14	2.096
86.86	2.328
94.94	2.757
104.96	3.291
114.84	3.810
125.00	4.349
135.77	4.906
145.61	5.403
155.99	5.898
165.87	6.353
175.90	6.776
186.08	7.202
196.06	7.570
206.29	7.949
215.51	8.270
226.01	8.613
236.26	8.918
245.67	9.168
255.32	9.458
266.21	9.723
276.10	9.958
286.48	1.021×10^{-1}
296.00	1.043^*

T	C_p
<u>CURVE 2</u>	
300	1.072×10^{-1}
400	1.257
500	1.352
600	1.412
700	1.455
800	1.488
900	1.517
1000	1.542
1100	1.566
1200	1.587

* Not shown on plot

FIG 49

SPECIFIC HEAT OF MOLYBDENUM TRIOXIDE MoO3

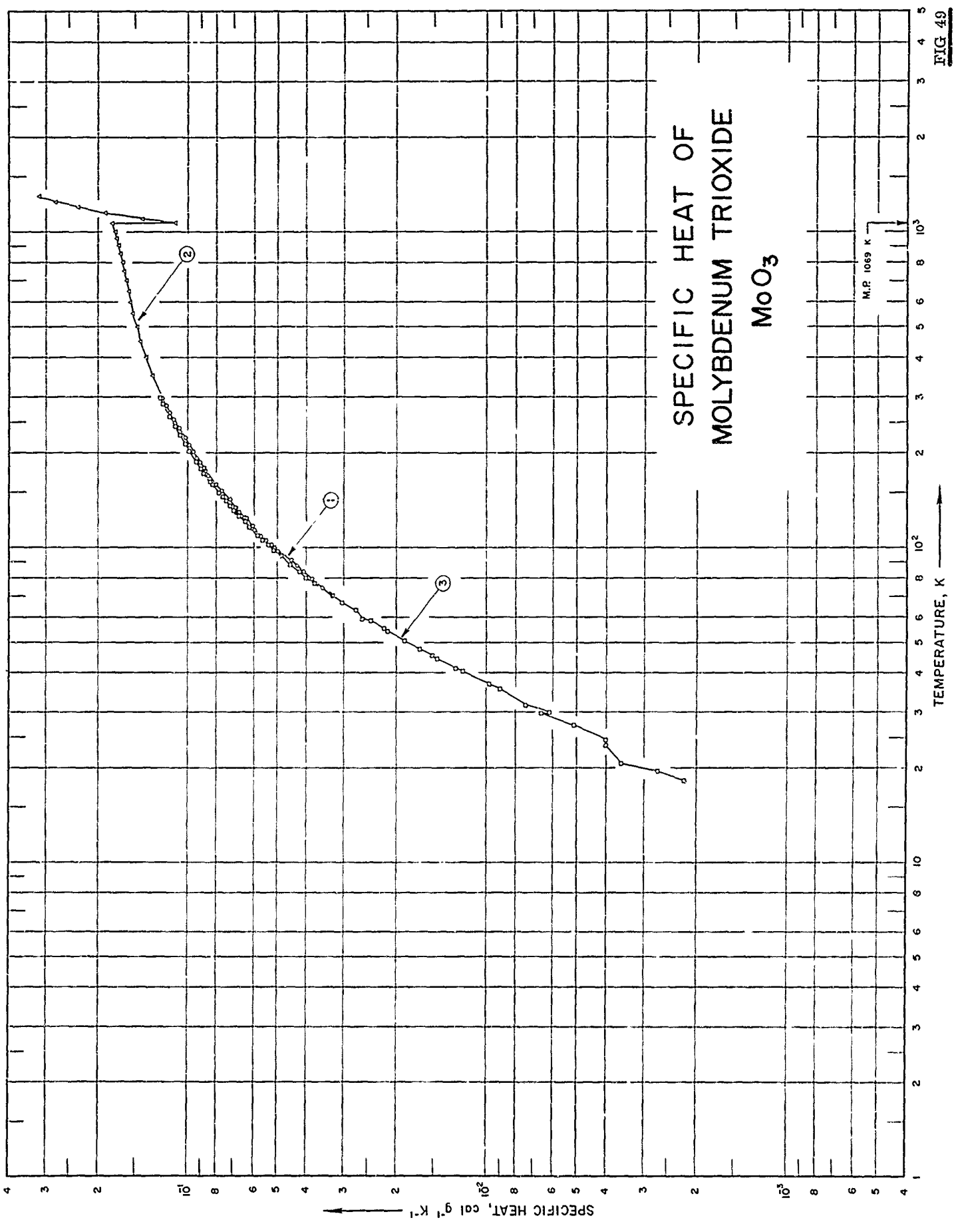

SPECIFICATION TABLE NO. 49 SPECIFIC HEAT OF MOLYBDENUM TRIOXIDE MoO_3

[For Data Reported in Figure and Table No. 49]

Curve No.	Ref. No.	Year	Temp. Range, K	Reported Error, %	Name and Specimen Designation	Composition (weight percent), Specifications and Remarks
1	106	1943	70-299			99.9 MoO_3 ; small transparent rhombic crystal.
2	107	1953	70-1300			MoO_3 ; $66.8 \pm 0.05 \text{ Mo}$, 0.005 non-volatile with HCl at 450 C, 0.001 insoluble in NH_3 , and trace of heavy metals and alkaline metals.
3	108	1956	20-300			MoO_3 , C. P. grade.

DATA TABLE NO. 49 SPECIFIC HEAT OF MOLYBDENUM TRIOXIDE MoO_3 [Temperature, T, K; Specific Heat, C_p , Cal g⁻¹ K⁻¹]

CURVE 1		CURVE 2		CURVE 3		CURVE 3 (cont.)		CURVE 3 (cont.)	
T	C_p	T	C_p	T	C_p	T	C_p	T	C_p
70.05	3.286×10^{-2}	70	3.283×10^{-2}	94.01	4.875×10^{-2}	260.27	1.154×10^{-1}	18.27	2.20×10^{-3}
74.48	3.54	75	3.565*	98.19	5.133	264.79	1.165*	20.86	3.58
79.75	3.84	100	5.143	102.18	5.387*	269.28	1.178*	23.68	4.03
83.95	4.10	125	6.520	106.02	5.619	273.74	1.188*	30.02	6.18
87.70	4.30	150	7.877*	109.73	5.837	278.15	1.200*	36.59	9.851
91.15	4.50	175	8.740	113.31	6.043*	282.54	1.208*	41.58	1.269×10^{-2}
97.55	5.00	225	1.075 $\times 10^{-1}$ *	116.79	6.232	286.89	1.219*	45.27	1.520*
101.79	5.27	250	1.104*	121.10	6.489	291.20	1.230*	48.36	1.731*
105.58	5.49	273.16	1.165*	126.20	6.750	295.49	1.239*	51.12	1.917*
109.22	5.72	275	1.170*	131.10	7.006	299.76	1.246	55.02	2.184*
114.00	5.98	298.16	1.227*	135.85	7.257				
117.65	6.08	300	1.226*	140.49	7.477				
124.72	6.38	350	1.329	145.03	7.695				
129.36	6.75	400	1.398	149.46	7.898*				
134.07	6.947	450	1.453	153.79	8.087*				
132.25	7.235	500	1.497	158.04	8.280				
144.65	7.420*	550	1.556	162.22	8.452*				
151.50	7.725	600	1.569	167.21	8.649*				
154.87	7.864*	650	1.600	172.98	8.882*				
159.51	8.101	700	1.629	178.65	9.089*				
163.47	8.267*	750	1.656	181.69	9.215*				
169.45	8.545	800	1.683	187.18	9.408*				
179.40	8.879*	850	1.708	192.58	9.606*				
182.50	9.087*	900	1.732	197.89	9.779*				
186.37	9.143	950	1.756	203.13	9.940				
192.46	9.358	1000	1.779	208.28	1.013 $\times 10^{-1}$ *				
201.05	9.622	1050	1.801*	213.38	1.027				
208.92	9.872*	(s) 1068.36	1.810	218.34	1.043*				
212.87	9.969	(l) 1068.36	1.113	223.30	1.058*				
220.05	1.018 $\times 10^{-1}$ *	1100	1.440	228.21	1.069				
224.12	1.027	1150	1.920	233.06	1.083*				
230.39	1.048*	1200	2.375	237.86	1.097*				
234.69	1.059*	1250	2.806	242.62	1.109				
240.15	1.079	1300	3.212						
250.67	1.109*								
254.86	1.120								
260.30	1.133*								
268.20	1.153								
280.32	1.181								
294.72	1.216*								
298.73	1.223								

* Not shown on plot

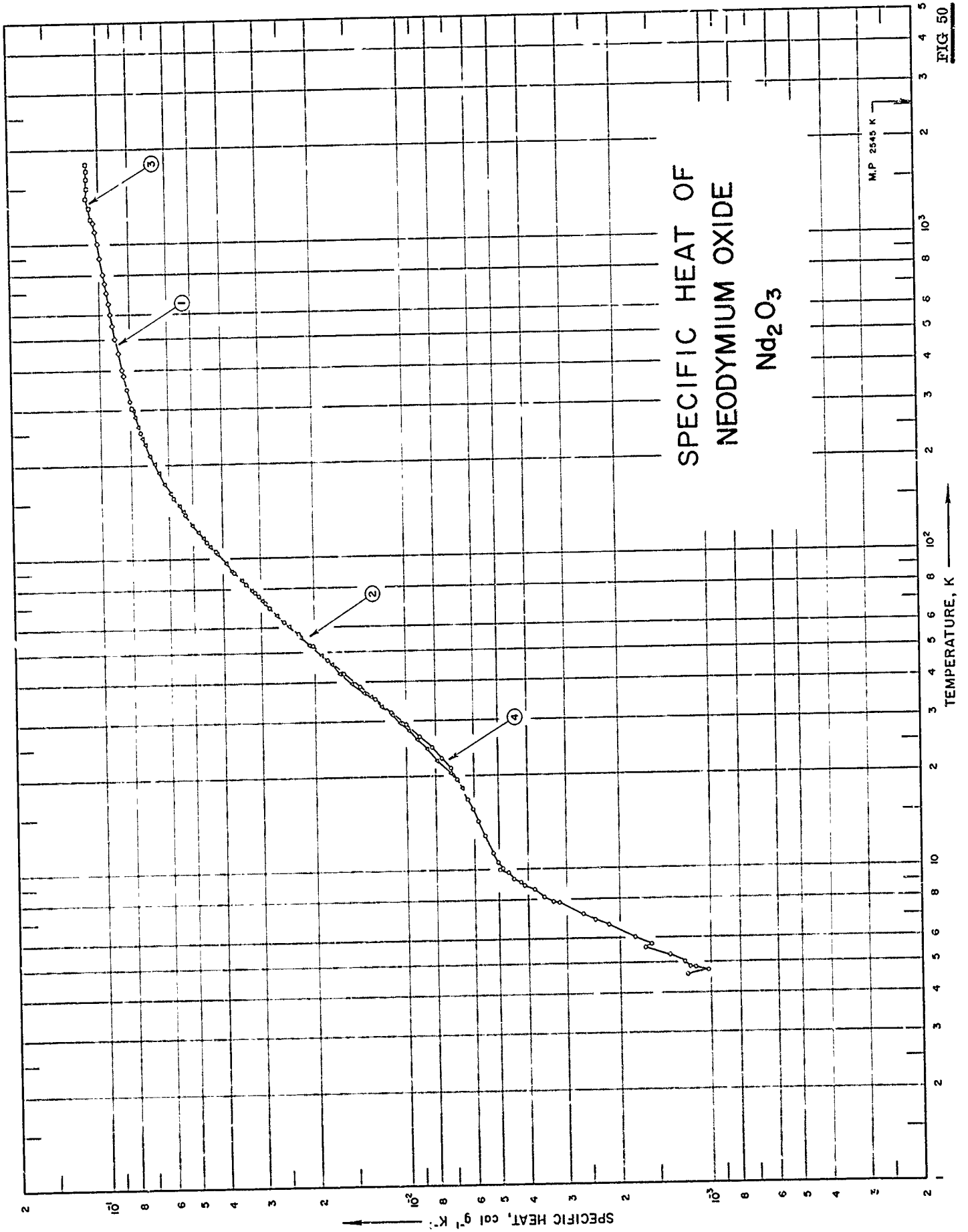

FIG 50

SPECIFICATION TABLE NO. 63 SPECIFIC HEAT OF NEODYMIUM OXIDE Nd_2O_3

[For Data Reported in Figure and Table No. 60]

Curve No.	Ref. No.	Year	Temp. Range, K	Reported Error, %	N. m. S. Specimen Designation	Composition (weight percent), Specifications and Remarks
1	82	1951	383-1171			
2	83	1958	18-298			99.9 Nd_2O_3 , <0.1 Pr_2O_3 , and <0.1 Sm_2O_3 ; sample supplied by the Lindsay Chemical Co.; heated to constant weight at 950 C for 24 hrs in air to decompose hydroxides or carbonates.
3	73	1962	298-1795	0.2		99.9 Nd_2O_3 ; hexagonal; measured in helium atmosphere.
4	72	1962	5-346	0.1		99.9 Nd_2O_3 ; sample supplied by the Lindsay Chemical Co; pelleted under 2000 - 4000 psi; fired at 1170 K; measured in helium atmosphere.

FIG 51

SPECIFIC HEAT OF NEPTUNIUM DIOXIDE

NpO₂

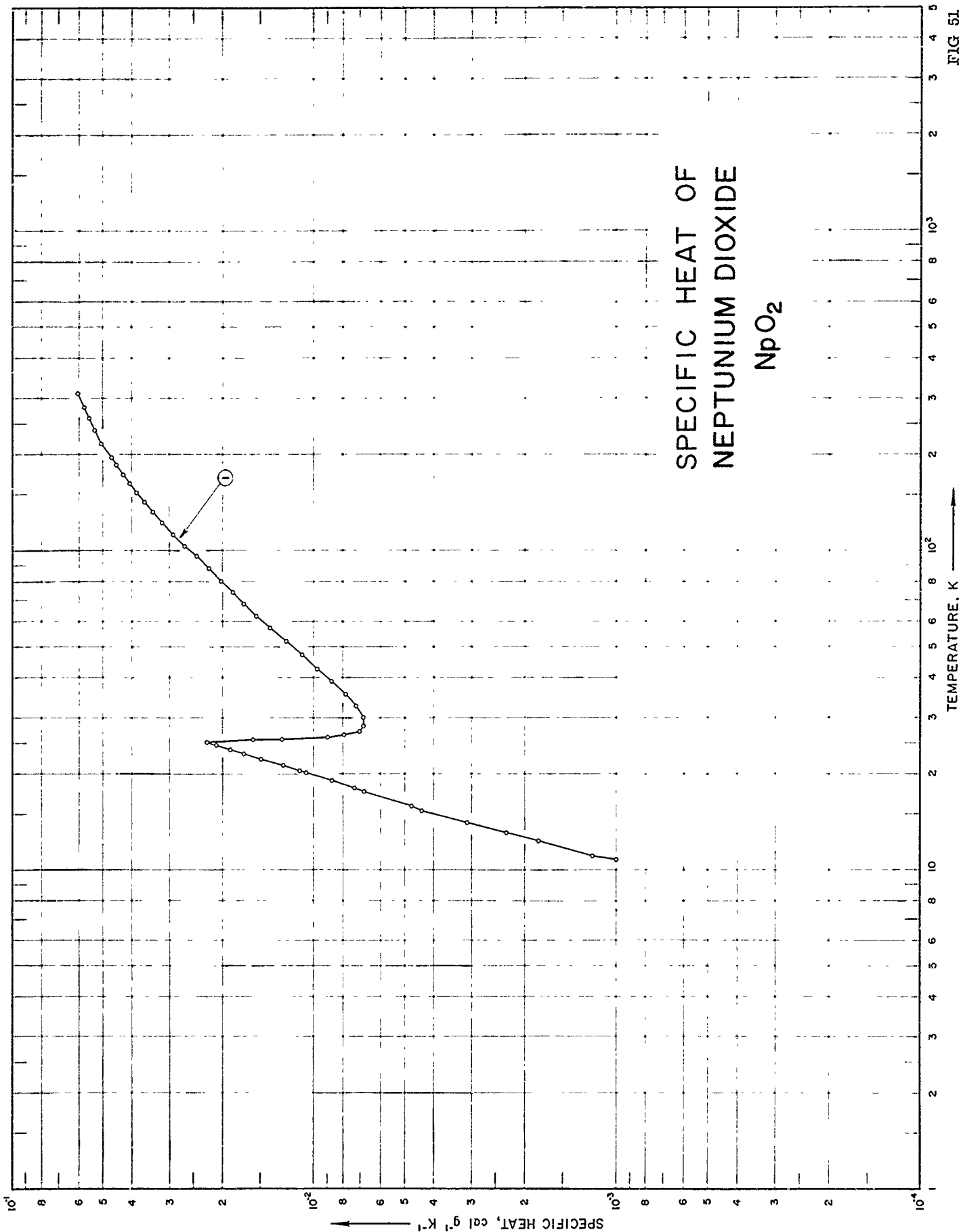

SPECIFICATION TABLE NO. 51 SPECIFIC HEAT OF NEPTUNIUM DIOXIDE NpO_2

[For Data Reported in Figure and Table No. 51]

Curve No.	Ref. No.	Year	Temp. Range, K	Reported Error, %	Name and Specimen Designation	Composition (weight percent), Specifications and Remarks
1	109	1953	10-312			99.9% NpO_2 , <0.1 total Cr, Fe, and Ca, Np^{237} prepared by U^{238} (n, 2n) U^{237} β^{-1} Np^{237} , hydroxide precipitated from acid solution and ignited to constant weight in air in Pt boat at 700 C.

DATA TABLE NO. 51 SPECIFIC HEAT OF NEPTUNIUM DIOXIDE, NpO_2
 [Temperature, T, K; Specific Heat, C_p , Cal $\text{g}^{-1}\text{K}^{-1}$]

T	C_p	T	C_p
CURVE 1		CURVE 1 (cont.)	
Series 1			
10.82	1.0×10^{-3}	25.71	1.59×10^{-2}
12.44	1.8	26.08	8.99×10^{-3}
14.09	3.1	26.52	7.95*
15.90	4.75	27.13	7.25*
17.67	6.80	27.99	6.95*
19.17	8.70	52.43	1.24×10^{-2} *
20.39	1.06×10^{-2}	57.52	1.39
21.42	1.26	62.78	1.54
22.44	1.49	68.40	1.70
23.29	1.70	74.18	1.85
23.98	1.88	80.73	2.02
24.63	2.10	86.10	2.22
25.21	2.26	96.52	2.44
25.84	1.27	104.79	2.67
26.60	7.91×10^{-3}	113.97	2.91
27.38	7.06	123.87	3.17
28.41	6.84	133.28	3.40
30.13	6.84	143.35	3.62
32.71	7.24	153.87	3.854
35.62	7.84	164.38	4.077
39.07	8.77	174.89	4.289
42.99	9.74	185.78	4.504
47.44	1.09×10^{-2}	196.70	4.683
52.27	1.23	207.36	4.869*
		217.73	5.010*
		228.55	5.155*
		239.12	5.300
		249.80	5.374*
		260.69	5.526*
		271.48	5.682*
		282.04	5.779
		292.42	5.846*
		302.64	5.868
		312.69	6.002
Series 2			
11.08	1.2×10^{-3}		
13.12	2.3		
15.40	4.39		
18.10	7.32		
20.54	1.11×10^{-2}		
22.47	1.52*		
23.88	1.87*		
24.76	2.15*		
25.27	2.26*		

* Not shown on Plot

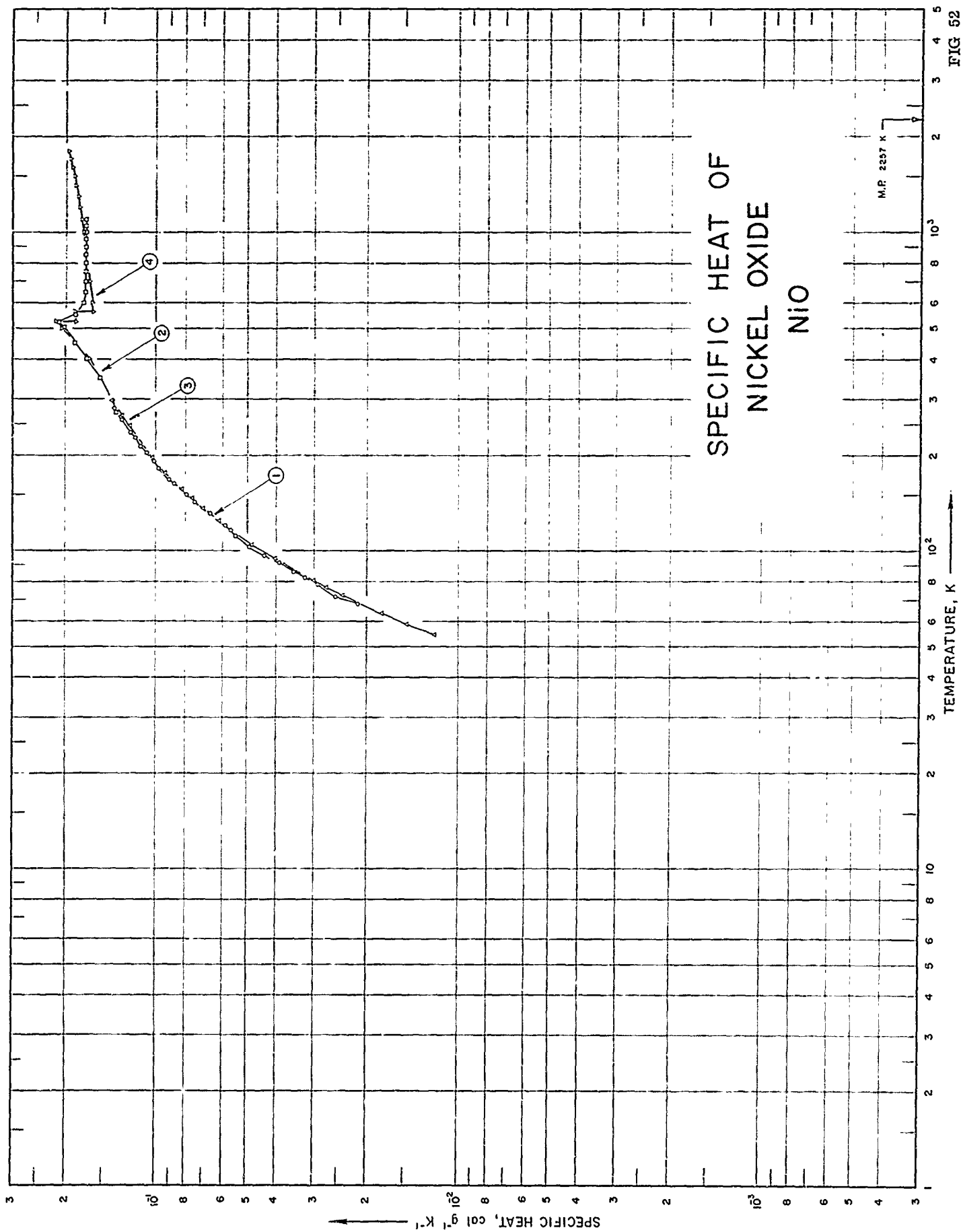

FIG 52

SPECIFICATION TABLE NO. 52 SPECIFIC HEAT OF NICKEL OXIDE NiO

[For Data Reported in Figure and Table No. 52]

Curve No.	Ref. No.	Year	Temp. Range, K	Reported Error, %	Name and Specimen Designation	Composition (weight percent), Specifications and Remarks
1	110	1940	68-297			<0.2 impurities; transparent cubic crystals.
2	111	1955	273-1100			78.51 - 78.54 Ni and 0.01 - 0.1 Si; prepared by decomposing $Ni(NO_3)_2 \cdot 6 H_2O$ and heating 8 hrs at 1000 C.
3	63	1957	54-296			99.96 NiO, 0.05 CoO, 0.02 acid insoluble, and 0.01 Na_2O ; prepared from reagent grade hexahydrate of nickelous nitrate and nickelous sulfate.
4	64	1958	298-1800	0.4		99.96 NiO, 0.05 CoO, 0.01 NO_2O , and 0.02 acid insoluble; prepared from reagent grade nickelous nitrate hexahydrate and nickelous sulfate hexahydrate.

DATA TABLE NO. 52 SPECIFIC HEAT OF NICKEL OXIDE, NiO
 [Temperature, T, K; Specific Heat, C_p , Cal $g^{-1}K^{-1}$]

CURVE 1		CURVE 2		CURVE 3 (cont.)		CURVE 4 (cont.)	
T	C_p	T	C_p	T	C_p	T	C_p
68.05	2.151×10^{-2}	273.16	1.357×10^{-1}	124.60	6.279×10^{-2}	900	$1.729 \times 10^{-1}*$
71.96	2.555	300	1.414*	135.88	7.053	1000	1.756
78.19	2.925	350	1.547	145.55	7.679	1100	1.783
82.07	3.216	400	1.700	155.86	8.327*	1200	1.810
85.89	3.514*	450	1.865	165.78	8.866	1300	1.837
86.70	$3.539*$	500	2.036	175.84	9.424	1400	1.864
91.08	3.918	523.16	2.117	185.78	9.941*	1500	1.891
94.42	4.141*	550	1.86	195.94	1.042×10^{-1}	1600	1.918
96.32	4.414	600	1.75	206.13	1.089*	1700	1.945
103.13	4.943	650	1.728	216.19	1.132*	1800	1.972
111.70	5.480	700	1.728	225.85	1.173*	1800	1.972
115.71	5.678	750	1.728	236.07	1.211		
120.33	5.975	800	1.728	245.63	1.246		
131.10	6.69	850	1.728	256.29	1.285*		
141.72	7.47	900	1.728	266.15	1.318		
150.08	7.94*	950	1.728	276.01	1.349*		
151.86	8.06*	1000	1.728	286.43	1.381		
162.37	8.75	1050	1.728	295.94	1.412		
168.09	9.10*	1100	1.728				
172.61	9.40*						
181.32	9.85						
183.01	$1.00 \times 10^{-1}*$						
190.75	1.02						
204.20	1.09						
213.13	1.14						
225.34	1.18						
235.37	1.22						
247.81	1.27*						
257.49	1.31*						
277.20	1.374*						
280.32	1.396						
296.68	1.413						

CURVE 3		CURVE 4	
T	C_p	T	C_p
54.28	1.20×10^{-2}	298.15	$1.418 \times 10^{-1}*$
58.93	1.488	300	1.420*
63.49	1.795*	400	1.670
68.10	2.117	500	2.055
72.47	2.433	525	2.162
76.74	2.745	550	1.858*
80.22	3.009*	565	1.838
83.81	3.271*	565	1.838
94.66	4.000	600	1.648
104.97	4.871*	700	1.675*
114.57	5.566*	800	1.702*

* Not shown on Plot

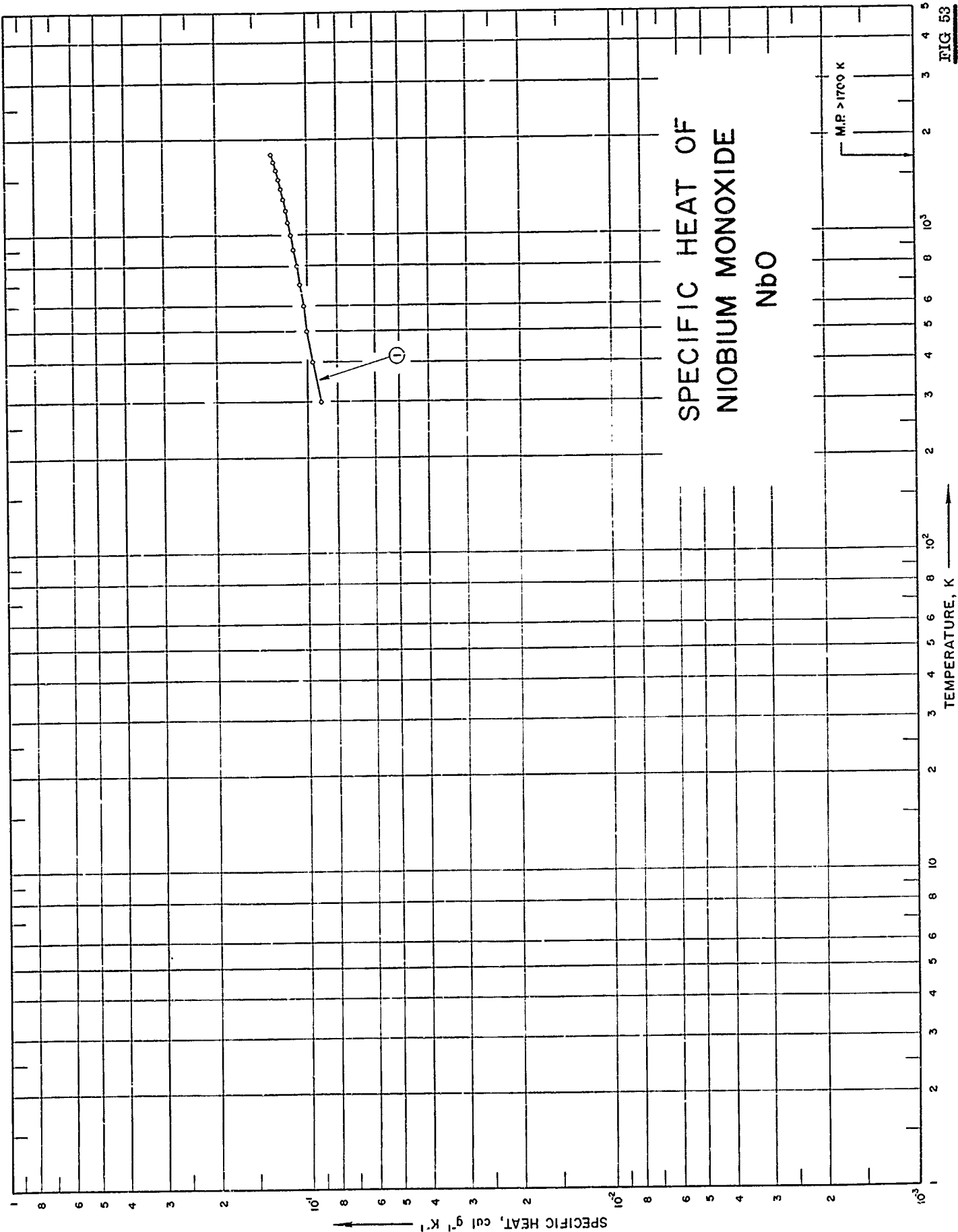

FIG 53

SPECIFICATION TABLE NO. 53 SPECIFIC HEAT OF NIOBIUM MONOXIDE NbO

[For Data Reported in Figure and Table No. 53]

Curve No.	Ref. No.	Year	Temp. Range, K	Reported Error, %	Name and Specimen Designation	Composition (weight percent), Specifications and Remarks
1	112	1960	300-1810			Prepared synthetically from high purity Nb ₂ O ₅ , carbothermic Nb and carbon black.

DATA TABLE NO. 53 SPECIFIC HEAT OF NIOBIUM MONOXIDE, NbO
 [Temperature, T, K; Specific Heat, C_p , Cal $g^{-1}K^{-1}$]

T	C_p
<u>CURVE 1</u>	
300	9.063×10^{-2}
400	9.632
500	1.001×10^{-1}
600	1.031
700	1.059
800	1.084
900	1.107
1000	1.130
1100	1.152
1200	1.176
1300	1.198
1400	1.220
1500	1.242
1600	1.264
1700	1.286
1800	1.308

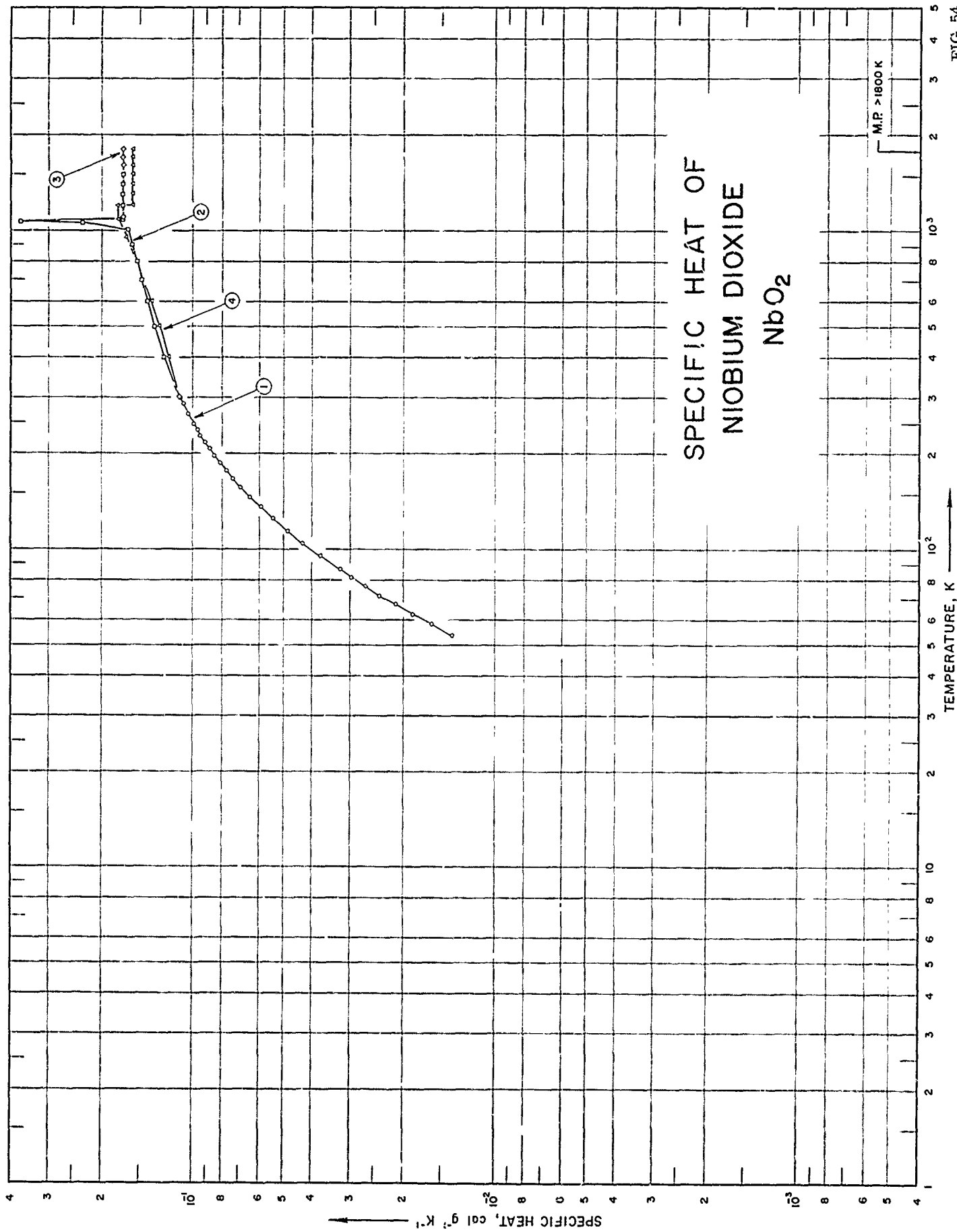

FIG. 54

SPECIFICATION TABLE NO. 54 SPECIFIC HEAT OF NIOBIUM DIOXIDE NbO₂

[For Data Reported in Figure and Table No. 54]

Curve No.	Ref. No.	Year	Temp. Range, K	Reported Error, %	Name and Specimen Designation	Composition (weight percent), Specifications and Remarks
1	75	1958	53-296			99.9 NbO ₂ .
2	113	1960	298-1500	1		74.42 Nb.
3	112	1960	300-1800			99.90 NbO ₂ ; prepared by reduction of niobium pentoxide with hydrogen for 4 hrs at 950-1000 C;
4	57	1961	298-1800	0.2		given 4 hrs more treatment in hydrogen at 950-1000 C.

DATA TABLE NO. 54 SPECIFIC HEAT OF NIOBIUM DIOXIDE, NbO₂[Temperature, T, K; Specific Heat, C_p, Cal g⁻¹K⁻¹]

CURVE 1		CURVE 2 (cont.)		CURVE 4 (cont.)	
T	C _p	T	C _p	T	C _p
53.45	1.387 x 10 ⁻²	1000	1.649 x 10 ⁻¹	β1090	1.777 x 10 ⁻¹
58.11	1.622	1010	1.654*	1100	1.777
62.58	1.874	1059	2.330	β1200	1.777
67.17	2.135	1069	3.716	γ1200	1.589
71.77	2.405	1080	1.704*	1300	1.589
76.56	2.676	1100	1.704*	1400	1.589
81.56	2.977	1200	1.704	1500	1.589
86.26	3.249	1300	1.704	1600	1.589
95.12	3.763	1400	1.704	1700	1.589
104.85	4.320	1500	1.704	γ1800	1.589
114.69	4.856	<u>CURVE 3</u>			
124.96	5.415	300	1.108 x 10 ⁻¹		
136.02	5.966	400	1.251*		
145.71	6.448	500	1.344*		
156.03	6.913	600	1.417*		
165.95	7.330	700	1.481*		
176.26	7.735	800	1.540*		
185.96	8.118	900	1.595*		
196.07	8.462	1000	1.649*		
206.31	8.799	1100	1.704		
216.49	9.103	1200	1.704*		
226.25	9.407	1300	1.704*		
236.23	9.647	1400	1.704*		
245.71	9.904	1500	1.704*		
256.53	1.017 x 10 ⁻¹ *	1600	1.704		
266.63	1.038*	1700	1.704		
276.19	1.059*	1800	1.704		
286.82	1.073*				
296.30	1.100				
		<u>CURVE 4</u>			
298.15	1.104 x 10 ⁻¹ *	0.298.15	1.100 x 10 ⁻¹ *		
300	1.106*	300	1.102*		
400	1.251	400	1.207		
500	1.344	500	1.296		
600	1.417	600	1.380		
700	1.481*	700	1.461*		
800	1.541	800	1.540*		
900	1.539	0.950	1.618		
900	1.555		1.657		

* Not shown on Plot

FIG 55

SPECIFIC HEAT OF DINIIOBIUM PENTAOXIDE Nb2O5

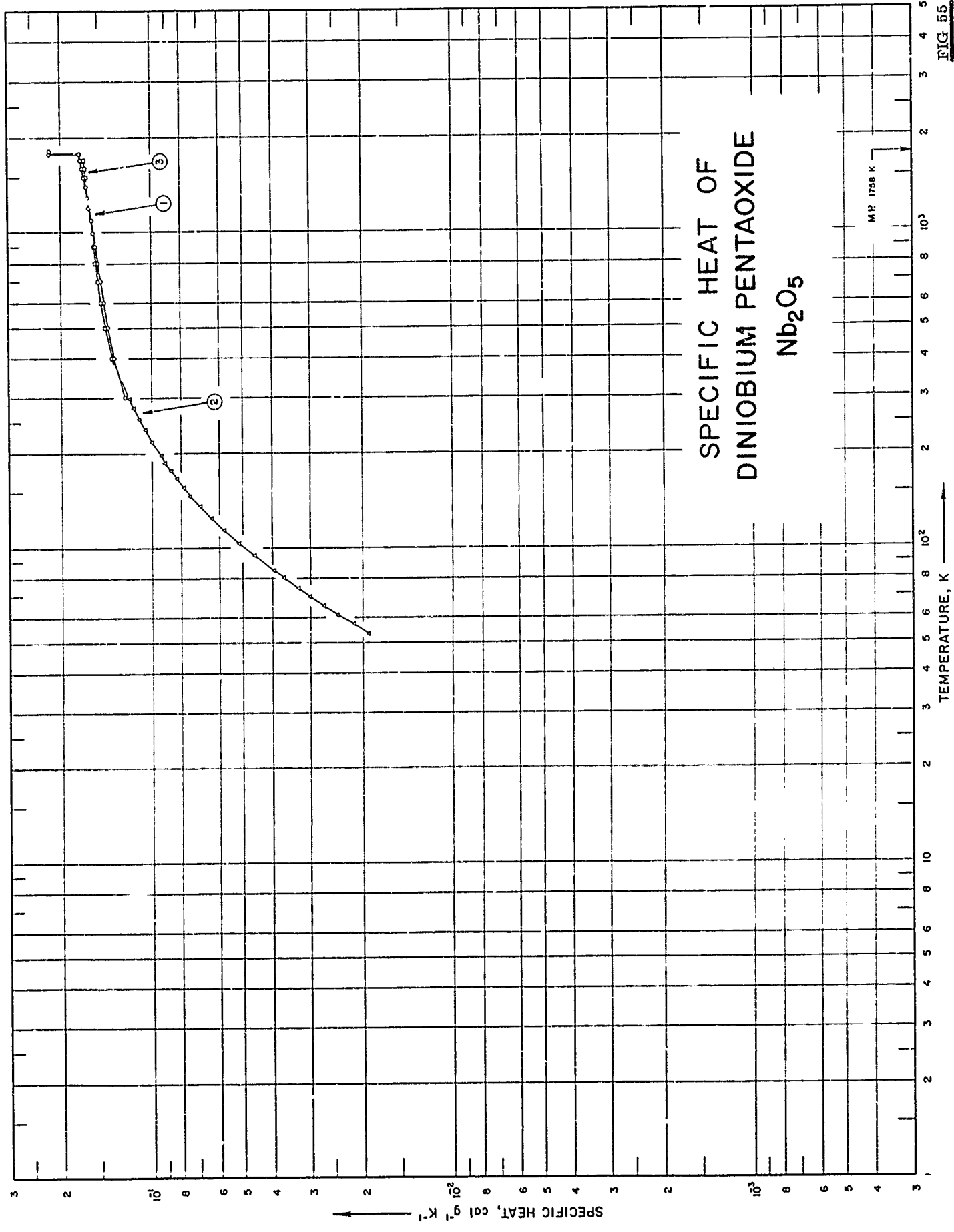

SPECIFICATION TABLE NO. 55 SPECIFIC HEAT OF DINIOBIUM PENTAOXIDE Nb₂O₅

[For Data Reported in Figure and Table No. 55]

Curve No.	Ref. No.	Year	Temp. Range, K	Reported Error, %	Name and Specimen Designation	Composition (weight percent), Specifications and Remarks
1	114	1953	300-1810	±0.5		0.03 Si, <0.05 Mg, and <0.01 Ti; crystalline; heated to 1050 C before measurements.
2	103	1954	53-298			<0.10 impurities.
3	112	1960	300-1700			

DATA TABLE NO. 55 SPECIFIC HEAT OF DINIOBIUM PENTAOXIDE Nb_2O_5 [Temperature, T, K; Specific Heat, C_p , Cal $g^{-1}K^{-1}$]

T	C_p	T	C_p
<u>CURVE 1</u>			
300	1.223×10^{-1}	216.60	1.00×10^{-1}
400	1.333	228.17	1.03*
500	1.395	236.41	1.05
600	1.438	245.82	1.074 ^A
700	1.473	256.19	1.100 ^A
800	1.503	266.49	1.120 ^A
900	1.529	276.76	1.145
1000	1.555	286.50	1.165*
1100	1.579	296.64	1.185*
1200	1.602	298.16	1.187
1300	1.625		
1400	1.647		
1500	1.669		
1600	1.691		
1700	1.712		
(s) 1785	1.731		
(l) 1785	2.178		
1800	2.178*		
1810	2.178		
<u>CURVE 2</u>			
53.24	1.93×10^{-2}	300	1.192×10^{-1} *
57.12	2.15	400	1.340
61.25	2.42	500	1.415
65.58	2.71	600	1.462
71.06	3.00	700	1.495
74.52	3.28	800	1.522
80.17	3.66	900	1.544*
84.45	3.94	1000	1.564*
94.75	4.60	1100	1.582*
104.36	5.18	1200	1.599*
114.54	5.79	1300	1.615*
124.62	6.35	1400	1.630*
136.03	6.94	1500	1.646
146.39	7.44	1600	1.661
155.98	7.86	1700	1.676
166.28	8.30		
176.36	8.67		
186.11	9.05		
196.13	9.32		
206.15	9.68*		

CURVE 3

300	1.192×10^{-1} *
400	1.340
500	1.415
600	1.462
700	1.495
800	1.522
900	1.544*
1000	1.564*
1100	1.582*
1200	1.599*
1300	1.615*
1400	1.630*
1500	1.646
1600	1.661
1700	1.676

CURVE 2

53.24	1.93×10^{-2}
57.12	2.15
61.25	2.42
65.58	2.71
71.06	3.00
74.52	3.28
80.17	3.66
84.45	3.94
94.75	4.60
104.36	5.18
114.54	5.79
124.62	6.35
136.03	6.94
146.39	7.44
155.98	7.86
166.28	8.30
176.36	8.67
186.11	9.05
196.13	9.32
206.15	9.68*

* Not shown on Plot

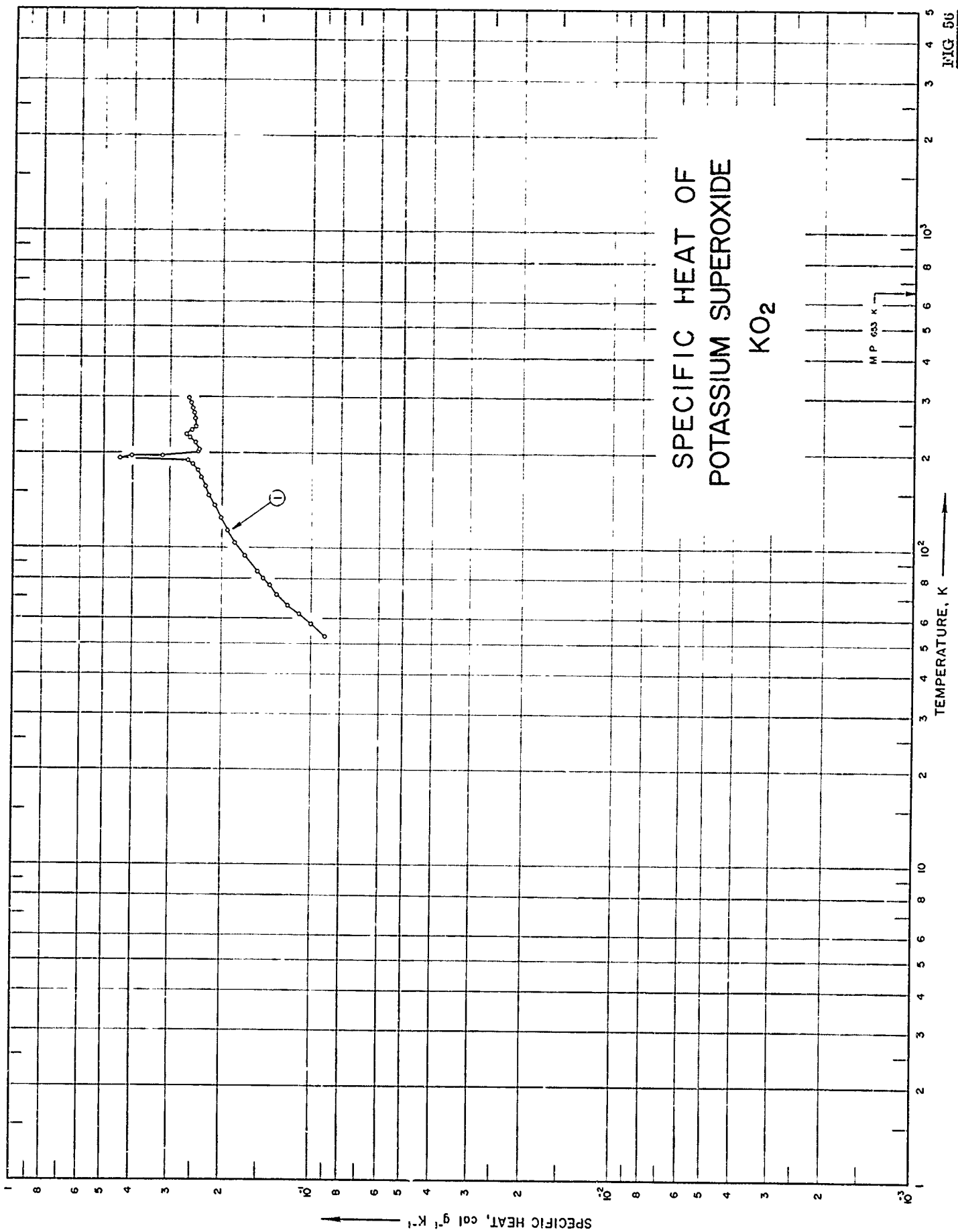

SPECIFICATION TABLE NO. 56 SPECIFIC HEAT OF POTASSIUM SUPEROXIDE KO_2

[For Data Reported in Figure and Table No. 56]

Curve No.	Ref. No.	Year	Temp. Range, K	Reported Error, %	Name and Specimen Designation	Composition (weight percent), Specifications and Remarks
1	240	1953	52-296			92.4 KO_2 , 3.5 Na_2O_3 , and 4.1 KCO_3 ; corrected for impurities.

DATA TABLE NO. 56 SPECIFIC HEAT OF POTASSIUM SUPEROXIDE KO_2 [Temperature, T, K; Specific Heat, C_p , Cal g⁻¹ K⁻¹]

T	C_p
<u>CURVE 1</u>	
52.59	9.053×10^{-2}
57.29	1.006×10^{-1}
62.05	1.116
66.72	1.218
71.49	1.312
76.19	1.398
80.00	1.463
84.07	1.533
94.83	1.695
104.70	1.820
114.88	1.940
125.06	2.045
136.09	2.145
146.17	2.229
156.04	2.300
166.36	2.374
176.21	2.446
183.54	2.525
186.22	2.567*
188.63	2.647
192.51	4.474
195.31	4.076
195.86	3.206
200.25	2.435
205.02	2.415
206.44	2.426*
216.68	2.494
219.56	2.522*
224.64	2.581
226.25	2.605*
228.96	2.651
232.87	2.633*
236.37	2.550
236.93	2.537*
241.47	2.478
246.14	2.476*
256.71	2.494
266.24	2.518*
276.41	2.547
286.62	2.575
296.72	2.602

Not shown on plot

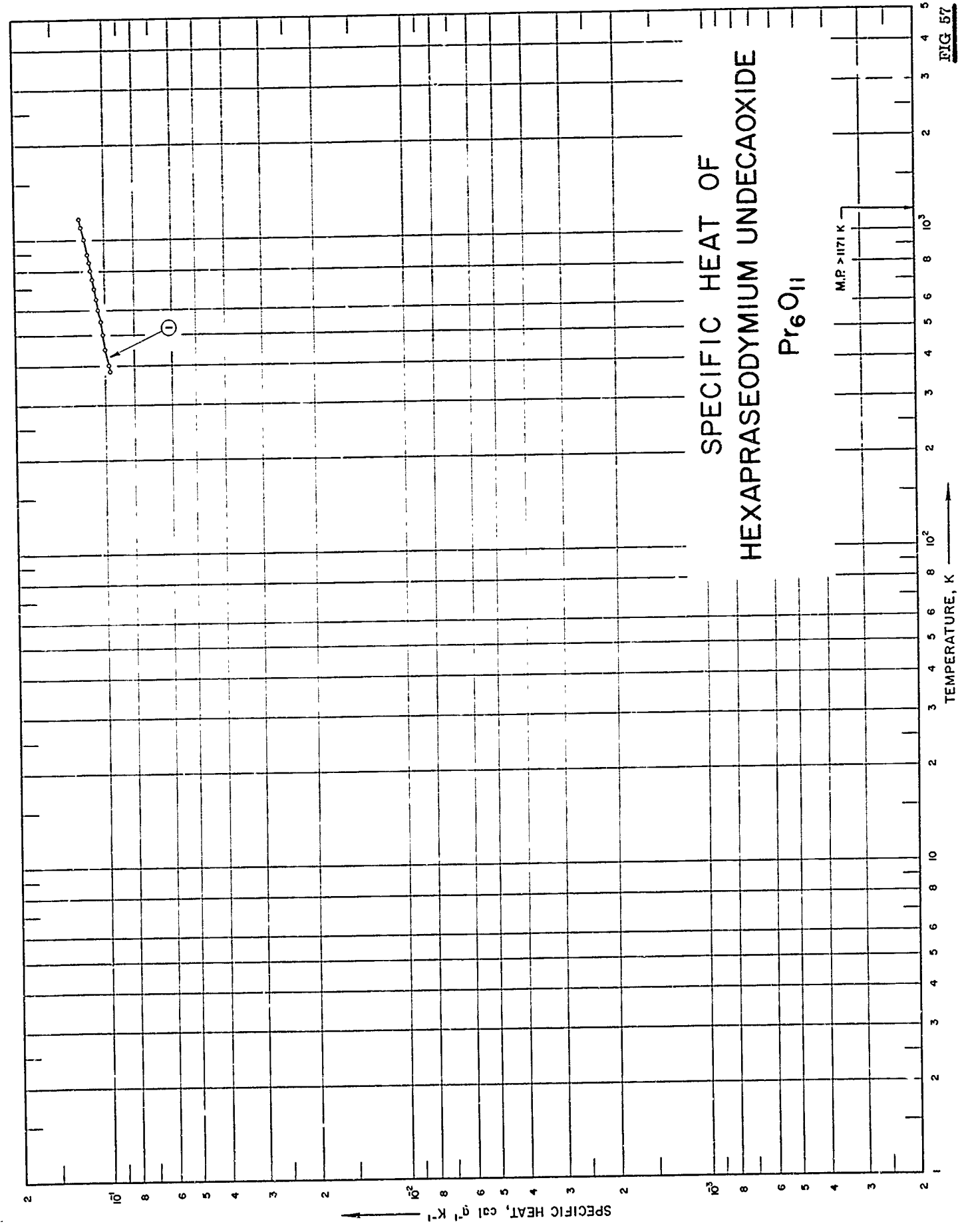

FIG. 57

SPECIFICATION TABLE NO. 57 SPECIFIC HEAT OF HEXAPRASEODYMIUM UNDECAOXIDE Pr_6O_{11}

[For Data Reported in Figure and Table No. 57]

Curve No.	Ref. No.	Year	Temp. Range, K	Reported Error, %	Name and Specimen Designation	Composition (weight percent), Specifications and Remarks
1	82	1951	383-1171			99.5 Pr_6O_{11}

DATA TABLE NO. 57 SPECIFIC HEAT OF HEXAPRASEODYMIUM UNDECAOXIDE Pr_6O_{11}
 [Temperature, T, K; Specific Heat, C_p , Cal $\text{g}^{-1}\text{K}^{-1}$]

T	C_p
CURVE 1	
383	9.689×10^{-2}
400	9.784
450	1.003×10^{-1}
500	1.025
550	1.044
600	1.061
650	1.078
700	1.094
750	1.109
800	1.124
850	1.138
900	1.152
950	1.166*
1000	1.180
1050	1.194*
1100	1.207*
1150	1.221*
1171	1.226

* Not shown on Plot

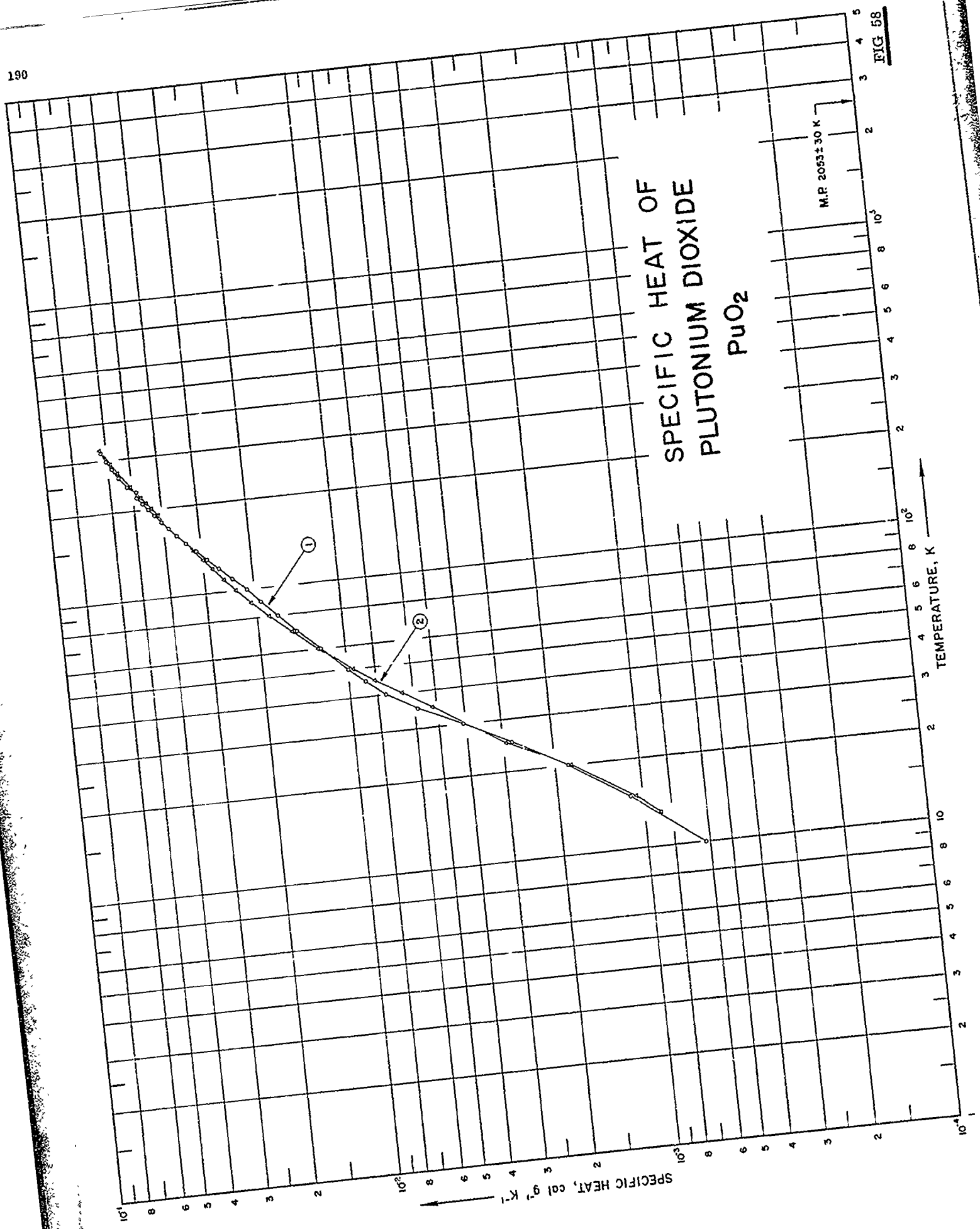

FIG 58

SPECIFICATION TABLE NC. 59 SPECIFIC HEAT OF PLUTONIUM DIOXIDE PuO₂

[For Data Reported in Figure and Table No. 58]

Curve No.	Ref. No.	Year	Temp. Range, K	Reported Error, %	Name and Specimen Designation	Composition (weight percent), Specifications and Remarks
1	115	1962	10-320			87.30 Pu, after initial preparation; 0.010 Ni, 0.008 Si, 0.004 C, 0.004 Fe, <0.002 Cr, 0.0004 Cu, 0.0004 Mn, and 0.0043 ppm other elements, after being compressed twice in steel die; 0.320 Fe, 0.240 Ni, 0.055 Am, 0.030 Si, 0.030 Mn, 0.0025 Cu, 0.0196 other elements; pressed at 50,000 psi and fired in air atmosphere at 1650 - 1700 C for 5 hrs.
2	116	1963	13-325			Same as above.

DATA TABLE NO. 58 SPECIFIC HEAT OF PLUTONIUM DIOXIDE PuO₂
 [Temperature, T, K; Specific Heat, C_p, Cal g⁻¹ K⁻¹]

T	CURVE 1		T	CURVE 2 (cont.)	
	C _p	C _p		C _p	C _p
10		6.204 x 10 ⁻⁴	25		2.92 x 10 ⁻³
15		1.102 x 10 ⁻³	30		4.12*
20		1.796	35		5.18
25		2.766	40		6.57
30		4.088	45		8.10
35		5.825	50		9.56
40		7.482	60		1.25 x 10 ⁻²
45		8.723	70		1.53
50		9.964	80		1.80
60		1.237 x 10 ⁻²	90		2.07
70		1.467	100		2.34
80		1.693	110		2.55
90		1.912	120		2.77
100		2.124	130		2.96
110		2.369	140		3.18
120		2.628	150		3.39*
130		2.883	160		3.58*
140		3.131	170		3.80*
150		3.369	180		3.98*
160		3.602	190		4.16
170		3.825	200		4.38
180		4.044	210		4.53
190		4.252	220		4.70
200		4.456	230		4.89*
210		4.650	240		5.07
220		4.836	250		5.25*
230		4.836	260		5.43*
240		5.190	270		5.58
250		5.354*	280		5.73*
260		5.511*	290		5.88
270		5.661*	298.15		5.99*
280		5.803	300		6.02*
290		5.937*	310		6.17*
298.15		6.040	320		6.28*
300		6.066*	325		6.35
310		6.186*			
320		6.299			
<u>CURVE 2</u>					
13		8.76 x 10 ⁻⁴			
15		1.06 x 10 ⁻³			
20		1.75			

* Not shown on plot

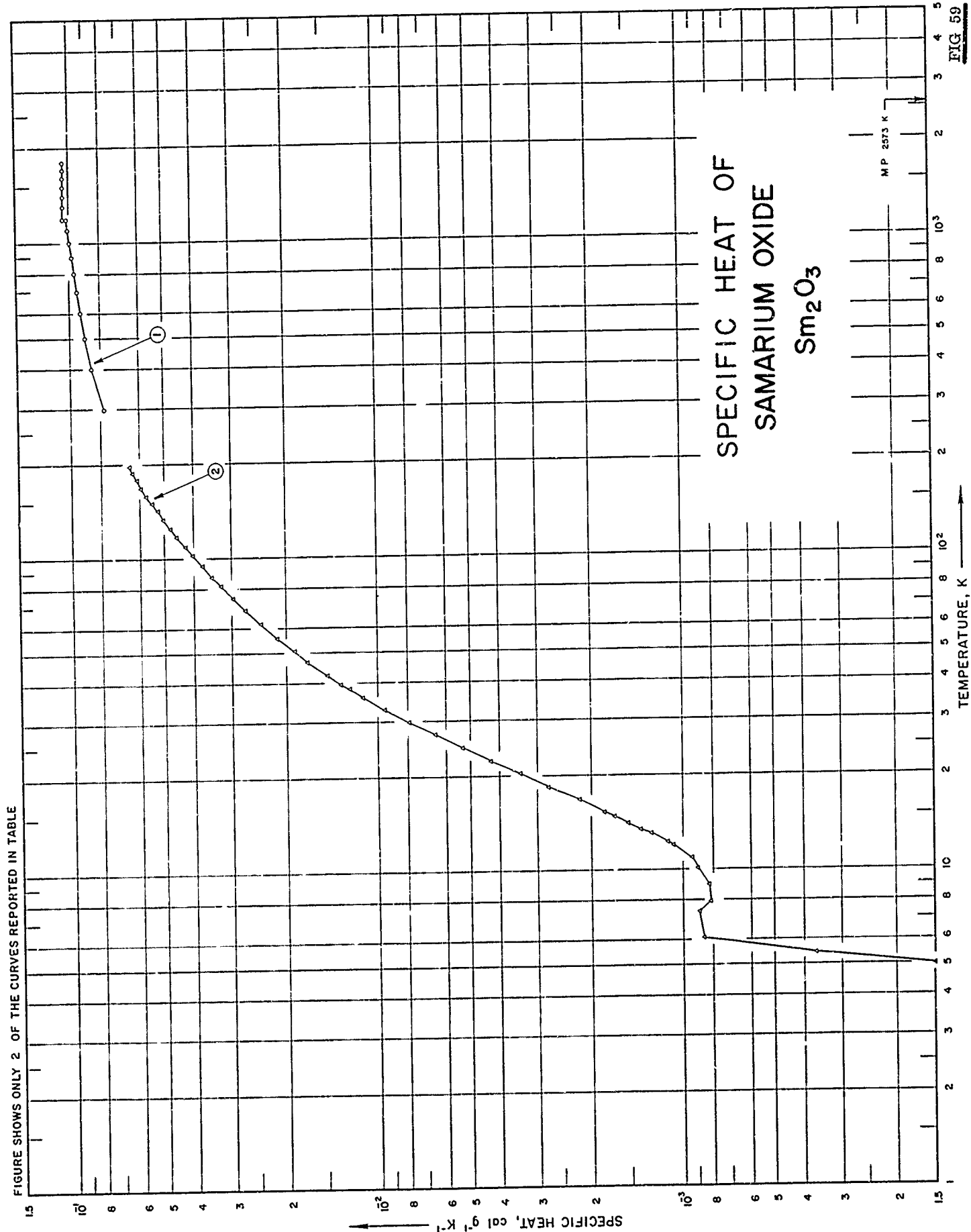

SPECIFICATION TABLE NO. 59 SPECIFIC HEAT OF SAMARIUM OXIDE Sm_2O_3

[For Data Reported in Figure and Table No. 59]

Curve No.	Ref. No.	Year	Temp. Range, K	Reported Error, %	Name and Specimen Designation	Composition (weight percent). Specifications and Remarks
1	73	1962	298-1798	0.2		99.9 Sm_2O_3 ; monoclinic; measured in helium atmosphere.
2	72	1962	5-346	0.1		99.9 Sm_2O_3 , 0.035 Ca, 0.020 Si, and 0.010 Eu; supplied by Michigan Chemical Co; pelleted under 2000 - 4000 psi; fired at 1170 K; measured under helium atmosphere.
3	73	1962	298-1149	0.2		99.9 Sm_2O_3 ; cubic, measured under helium atmosphere.

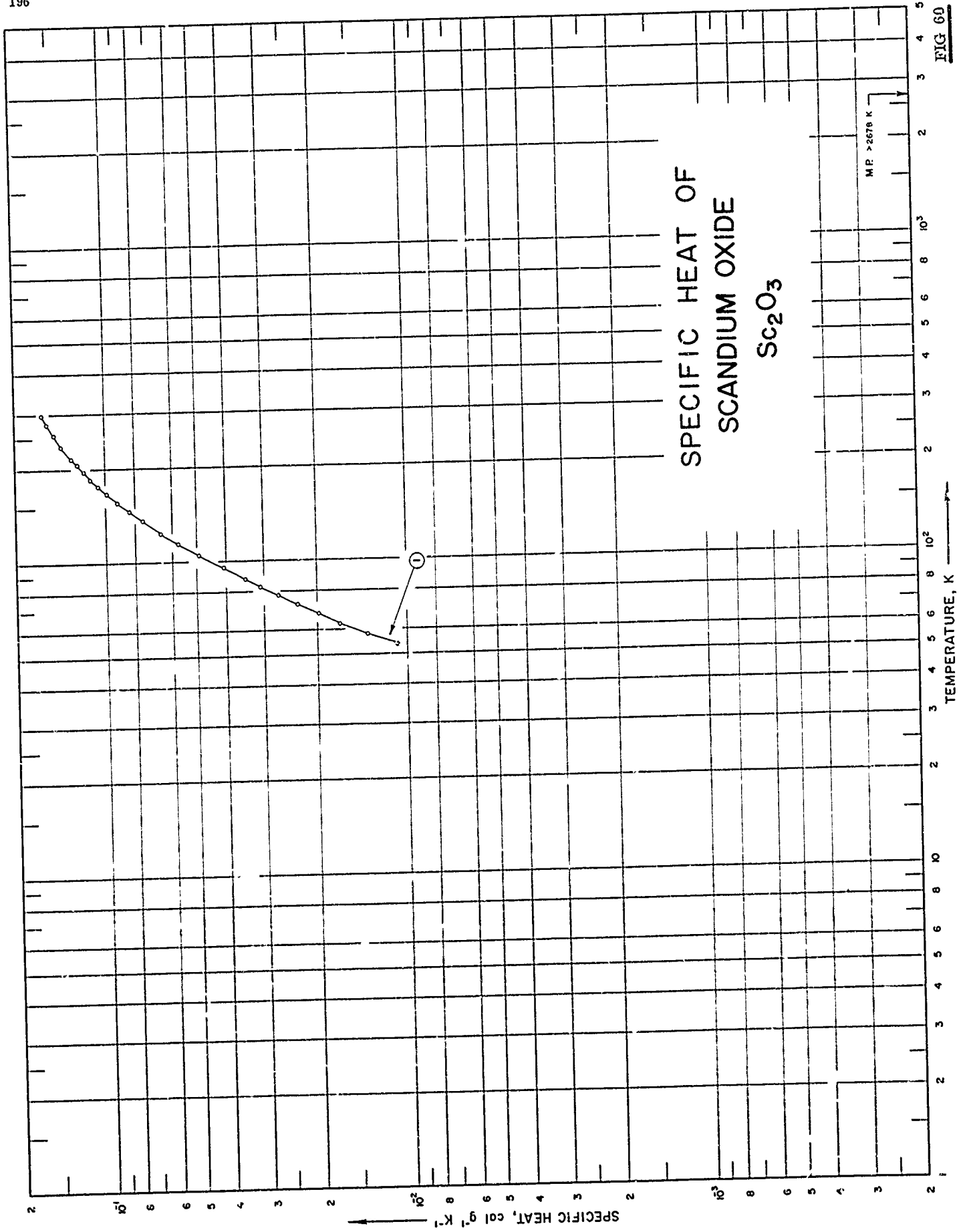

FIG 60

SPECIFICATION TABLE NO. 60 SPECIFIC HEAT OF SCANDIUM OXIDE Sc_2O_3

[For Data Reported in Figure and Table No. 60]

Curve No.	Ref. No.	Year	Temp. Range, K	Reported Error, %	Name and Specimen Designation	Composition (weight percent), Specifications and Remarks
1	58	1963	53-296	0.10		99.9 Sc_2O_3 ; measured in nitrogen atmosphere.

DATA TABLE NO. 60 SPECIFIC HEAT OF SCANDIUM OXIDE, Sc_2O_3 [Temperature, T, K; Specific Heat, C_p , Cal $\text{g}^{-1}\text{K}^{-1}$]

T	C_p
	CURVE 1
53.33	1.083×10^{-2}
57.88	1.361
62.66	1.684
67.40	1.978
72.37	2.312
77.45	2.692
82.61	3.088
87.45	3.454
95.25	4.086
105.01	4.914
114.82	5.768
124.49	6.587
135.77	7.541
145.51	8.361
156.08	9.180
166.13	9.919
176.21	1.064×10^{-1}
186.12	1.129
196.38	1.191
206.47	1.249
216.17	1.302*
226.23	1.355*
236.46	1.405*
246.33	1.447*
256.42	1.490*
266.74	1.527
276.64	1.564
286.92	1.595
296.27	1.629

* Not shown on Plot

SPECIFIC HEAT OF SILVER OXIDE

Ag₂O

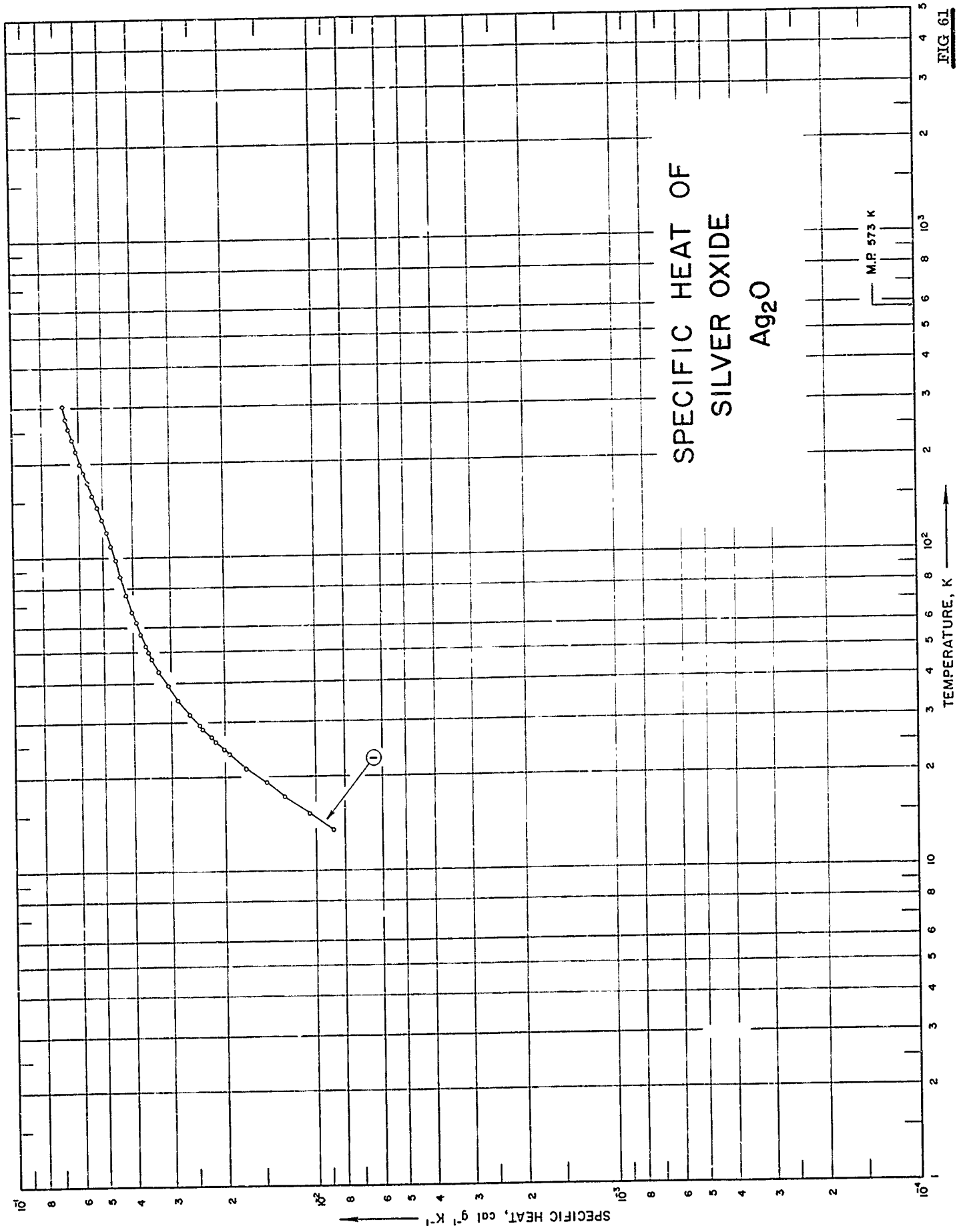

FIG 61

SPECIFICATION TABLE NO. 61 SPECIFIC HEAT OF SILVER OXIDE Ag_2O

[For Data Reported in Figure and Table No. 61]

Curve No.	Ref. No.	Year	Temp. Range, K	Reported Error, %	Name and Specimen Designation	Composition (weight percent), Specifications and Remarks
1	117	1962	14-302			~98.9 Ag_2O , 0.05 Cu, 0.04 H_2O and 0.01 other impurities; prepared by long heating in contact with water at 325 C under 200 atmosphere of O_2 ; annealed; measured in helium atmosphere.

DATA TABLE NO. 61 SPECIFIC HEAT OF SILVER OXIDE Ag_2O
 [Temperature, T, K; Specific heat, C_p , Cal $\text{g}^{-1}\text{K}^{-1}$]

T	C_p	T	C_p
	CURVE 1		CURVE 1 (cont.)
Series 1			
13.5	8.760×10^{-3}	198.85	5.955×10^{-2}
15.28	1.053×10^{-2}	204.77	6.011*
17.22	1.277	211.08	6.080
19.12	1.463	217.57	6.153
21.25	1.705	223.79	6.210*
23.58	1.946	230.21	6.274*
25.93	2.153	237.15	6.330*
28.44	2.386	243.70	6.408*
31.51	2.619	250.06	6.464*
35.05	2.870	256.28	6.503
39.10	3.098	262.56	6.568*
43.44	3.314	268.81	6.624*
47.74	3.491	275.47	6.671
52.22	3.651	281.52	6.714*
57.03	3.797	288.07	6.740*
62.09	3.923	294.66	6.775*
67.01	4.048	301.67	6.796
76.12	4.225*		
81.40	4.320	Series 2	
87.16	4.419	24.50	2.020
92.87	4.496*	26.63	2.218
98.27	4.578*	29.17	2.434
103.66	4.656*	32.43	2.680*
109.25	4.729*	36.25	2.943*
114.86	4.820*	40.49	3.167*
120.55	4.898	45.38	3.383*
126.47	4.997*	50.52	3.590
132.62	5.079*	55.35	3.750*
138.80	5.183	60.11	3.884*
144.95	5.260	64.78	3.996*
150.98	5.338*	69.64	4.099*
157.12	5.433	74.36	4.181*
163.07	5.511*	78.97	4.272*
168.82	5.580*		
174.90	5.665		
180.95	5.735*		
186.92	5.808*		
193.02	5.882		

* Not shown on Plot

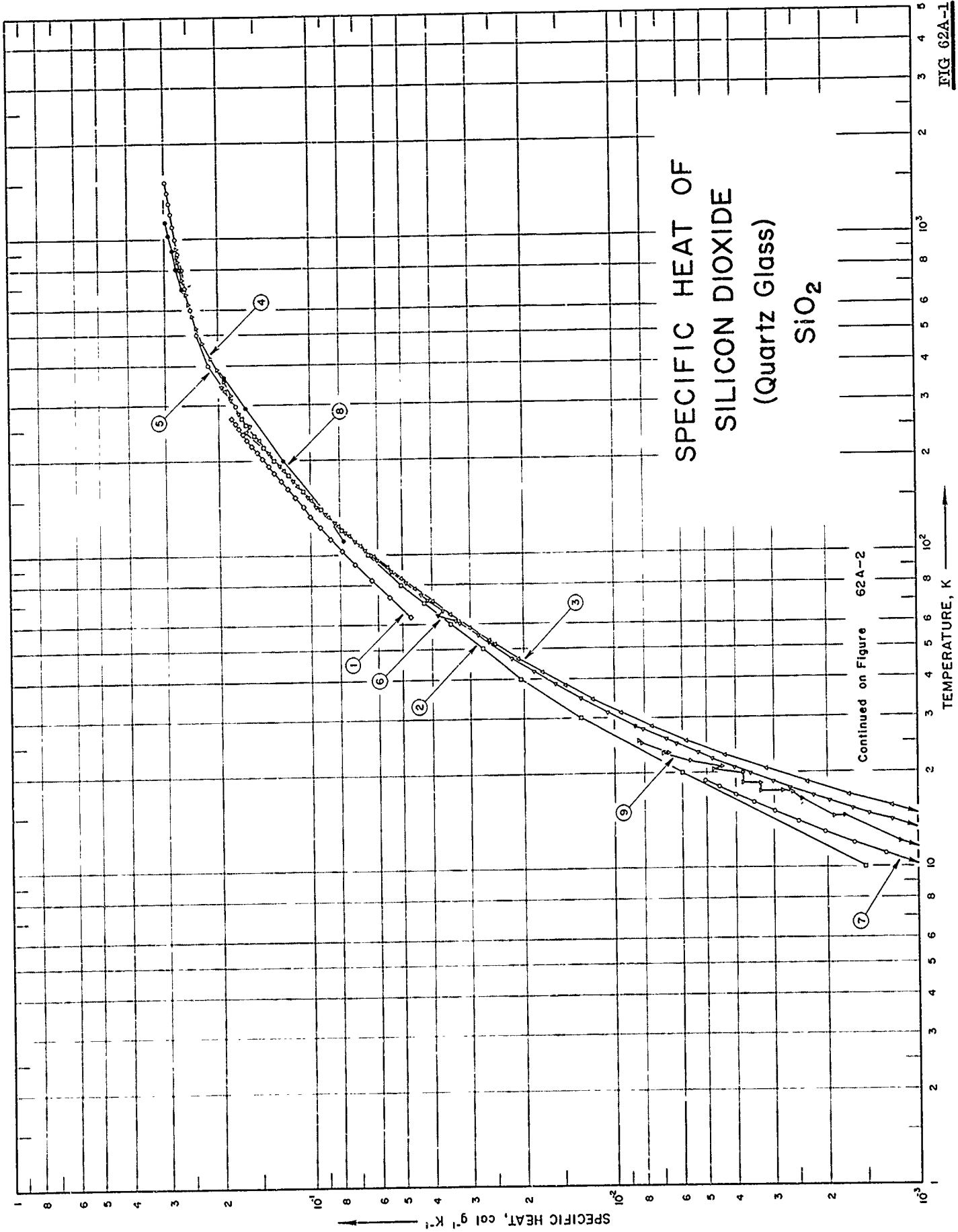
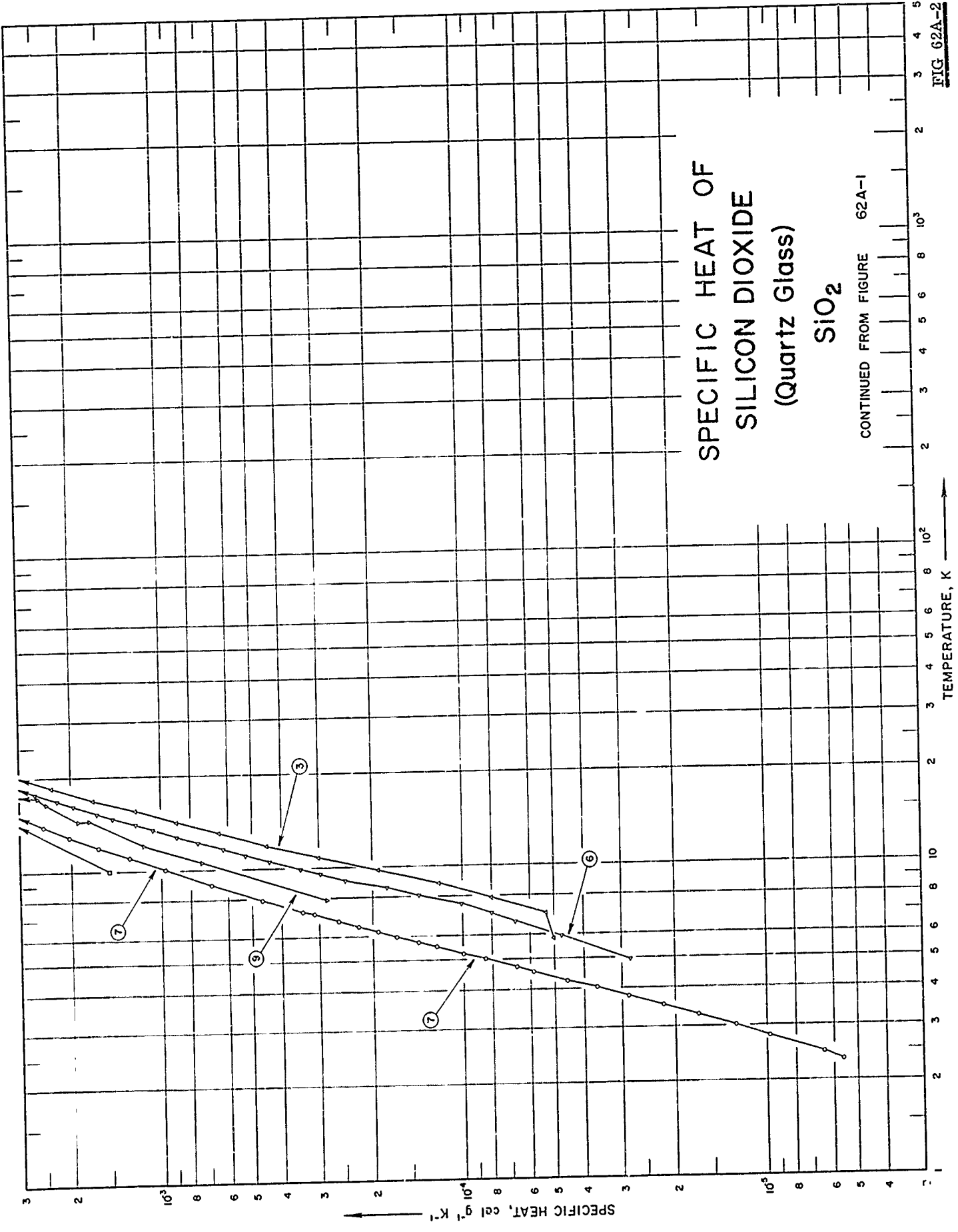

FIG 62A-1



SPECIFIC HEAT OF
SILICON DIOXIDE
(Quartz Glass)
SiO₂

CONTINUED FROM FIGURE 62A-1

FIG 62A-2

SPECIFICATION TABLE NO. 62-A SPECIFIC HEAT OF SILICON DIOXIDE (Quartz Glass) SiO_2

[For Data Reported in Figure and Table No. 62-A.]

Curve No.	Ref. No.	Year	Temp. Range, K	Reported Error, %	Name and Specimen Designation	Composition (weight percent), Specifications and Remarks
1	118	1911	63-273			Glass.
2	119	1921	10-273			Glass; amorphous.
3	120	1956	5-344	5 at 5K 1 at 10K <0.1 above 25K		99.97 SiO_2 ; specimen from Brazil; vitreous silica; irradiated with neutrons for 30 days at 35 C with damaging flux of 2.5×10^{19} nvt.
4	121	1936	323-935			Transparent without blemish; from Brazil.
5	122	1941	298-1520			99.95 SiO_2 and 0.05 residue; silica glass; prepared from transparent vitreous silica tubing by crushing and screening out fines.
6	120	1956	5-343	5 at 5K 1 at 10K <0.1 above 25K		99.97 SiO_2 ; specimen from Brazil; vitreous silica; irradiated with neutrons for 30 days at 35 C with damaging flux of 7.7×10^{19} nvt.
7	123	1959	2-18			Optical quality; annealed at 1100 C after crushing.
8	9	1960	111-1144			Sample obtained from Hanovia Chemical Co; fused silica.
9	124	1962	8-25			Silica; irradiated with 7.7×10^{19} n cm ⁻² fast neutrons.

DATA TABLE NO. 62-A SPECIFIC HEAT OF SILICON DIOXIDE (Quartz Glass) SiO₂[Temperature, T, K; Specific Heat, C_p, Cal g⁻¹K⁻¹]

T	C _p	T	C _p	T	C _p	T	C _p	T	C _p		
<u>CURVE 1</u>											
63.15	4.7 x 10 ⁻²	5.81	5.0 x 10 ⁻⁵	233.65	1.482 x 10 ⁻¹	1300	2.899 x 10 ⁻¹	192.60	1.265 x 10 ⁻¹		
73.15	5.5	7.00	5.3	243.67	1.532*	1400	2.942	211.70	1.371		
83.15	6.3	7.90	8.0	253.60	1.580*	1500	2.984*	221.46	1.422*		
93.15	7.15	8.81	1.2 x 10 ⁻⁴	263.50	1.626*	1520	2.992	<u>CURVE 6</u>			
103.15	7.9	9.78	1.91	273.44	1.676*	<u>Series 1</u>					
113.15	8.6	10.83	3.01	283.43	1.716*	192.60	4.38	10.58	4.38		
123.15	9.3	11.95	4.49	285.09	1.720*	211.70	6.26	11.66	6.26		
133.15	1.00 x 10 ⁻¹	13.13	6.46	295.05	1.762*	221.46	8.89	12.84	8.89		
143.15	1.06	14.28	8.94	305.04	1.803*	<u>Series 2</u>					
153.15	1.13	15.58	1.255 x 10 ⁻³	314.84	1.841	61.96	2.224	16.94	2.224		
163.15	1.19	16.99	1.696	324.48	1.879*	74.65	3.014	18.73	3.014		
173.15	1.25	18.61	2.325	334.16	1.916*	81.43	4.078	20.84	4.078		
183.15	1.32	20.51	3.182	344.04	1.953*	88.58	5.342	23.17	5.342		
193.15	1.38	22.79	4.352	<u>CURVE 4</u>						25.65	6.800
202.15	1.44	25.38	5.833	323.95	1.830 x 10 ⁻¹	96.26	3.357 x 10 ⁻²	28.32	8.60		
213.15	1.50	28.15	7.573	356.55	1.935	104.08	6.646	34.72	1.30		
223.15	1.56	31.14	9.57	388.85	2.028	110.31	7.120	38.53	1.58		
233.15	1.62	34.48	1.19 x 10 ⁻²	420.95	2.128	126.67	8.347	42.46	1.856		
243.15	1.67	38.11	1.46	472.65	2.262	135.13	9.961	46.81	2.199		
253.15	1.72	42.01	1.746	528.65	2.362	143.93	9.580	51.84	2.573		
263.15	1.77	46.60	2.094	576.25	2.441	153.22	1.021 x 10 ⁻¹	<u>Series 4</u>			
273.15	1.82	51.85	2.496	624.25	2.497	163.09	1.085*	7.0	8.0 x 10 ⁻⁵		
<u>CURVE 2</u>											
10	1.5 x 10 ⁻³	53.24	2.601	673.35	2.556	173.12	1.149	8.08	1.4 x 10 ⁻⁴		
20	6.0	58.85	3.034	747.85	2.636	182.74	1.207*	9.07	2.46		
30	1.3 x 10 ⁻²	64.61	3.490	801.35	2.676	192.11	1.261*	9.96	3.46		
40	2.05	71.13	3.998	851.85	2.706	226.45	1.448*	11.12	5.29		
50	2.72	78.01	4.544	887.85	2.748	246.69	1.499*	12.29	7.54		
60	3.48	84.30	5.051	935.85	2.748	266.49	1.641*	13.51	1.07 x 10 ⁻³		
70	4.26	91.32	5.504	<u>CURVE 5</u>						14.84	1.46
80	5.06	99.05	6.201	298.15	1.765 x 10 ⁻¹	256.62	1.598	16.29	1.969		
100	6.43	107.16	6.824	300	1.775*	266.49	1.684*	17.95	2.661		
120	7.90	115.54	7.463	400	2.161	276.39	1.712	19.91	3.583		
140	9.23	124.07	8.105	500	2.359	282.66	1.753*	22.15	4.792		
160	1.06 x 10 ⁻¹	132.77	8.743	600	2.484	292.21	1.794*	24.69	6.283		
180	1.19	141.62	9.368*	700	2.574	302.13	1.834*	27.60	8.077		
200	1.32	150.25	9.966	800	2.645	312.34	1.870*	30.85	1.03 x 10 ⁻²		
220	1.43	159.11	1.056 x 10 ⁻¹	900	2.705	322.28	1.912*	34.40	1.28*		
240	1.53	166.51	1.103	1000	2.759	332.78	1.952	38.15	1.55*		
260	1.63	176.33	1.164*	1100	2.809	343.45	1.952	<u>Series 3</u>			
273	1.682	185.91	1.222	1200	2.855	<u>CURVE 7</u>					
<u>CURVE 3 (cont.)</u>											
<u>CURVE 5 (cont.)</u>											
<u>CURVE 6 (cont.)</u>											
<u>CURVE 7</u>											
<u>CURVE 6 (cont.)</u>											
<u>CURVE 7</u>											

* Not shown on plot

DATA TABLE NO. 62-A (continued)

T	C _p	T	C _p
<u>CURVE 7 (cont.)</u>			
17.051	4.004×10^{-3}	Series 4	
18.015	4.540	14.6	1.90×10^{-3}
18.980	5.077	17.4	2.60
<u>CURVE 8</u>			
111.5	7.8×10^{-2}	20.5	4.76
144	9.3	23.1	6.97
199	1.23×10^{-1}	25.4	8.37
293	1.64		
366	1.92		
477	2.26*		
588	2.48*		
699	2.63		
810	2.75		
922	2.84		
1033	2.92		
1144	2.98		
<u>CURVE 9</u>			
Series 1			
12.1	1.15×10^{-3}		
14.6	1.75		
16.5	2.43		
18.5	3.31		
20.9	4.43		
Series 2			
17.5	2.80×10^{-1}		
18.6	3.78		
20.0	3.78		
21.9	5.51		
23.2	6.09		
24.9	8.16		
Series 3			
7.9	2.83×10^{-4}		
10.6	7.32		
14.4	1.75×10^{-3} *		
17.5	3.31		

* Not shown on plot

FIG 62B

SPECIFIC HEAT OF SILICON DIOXIDE (Quartz Crystal) SiO_2

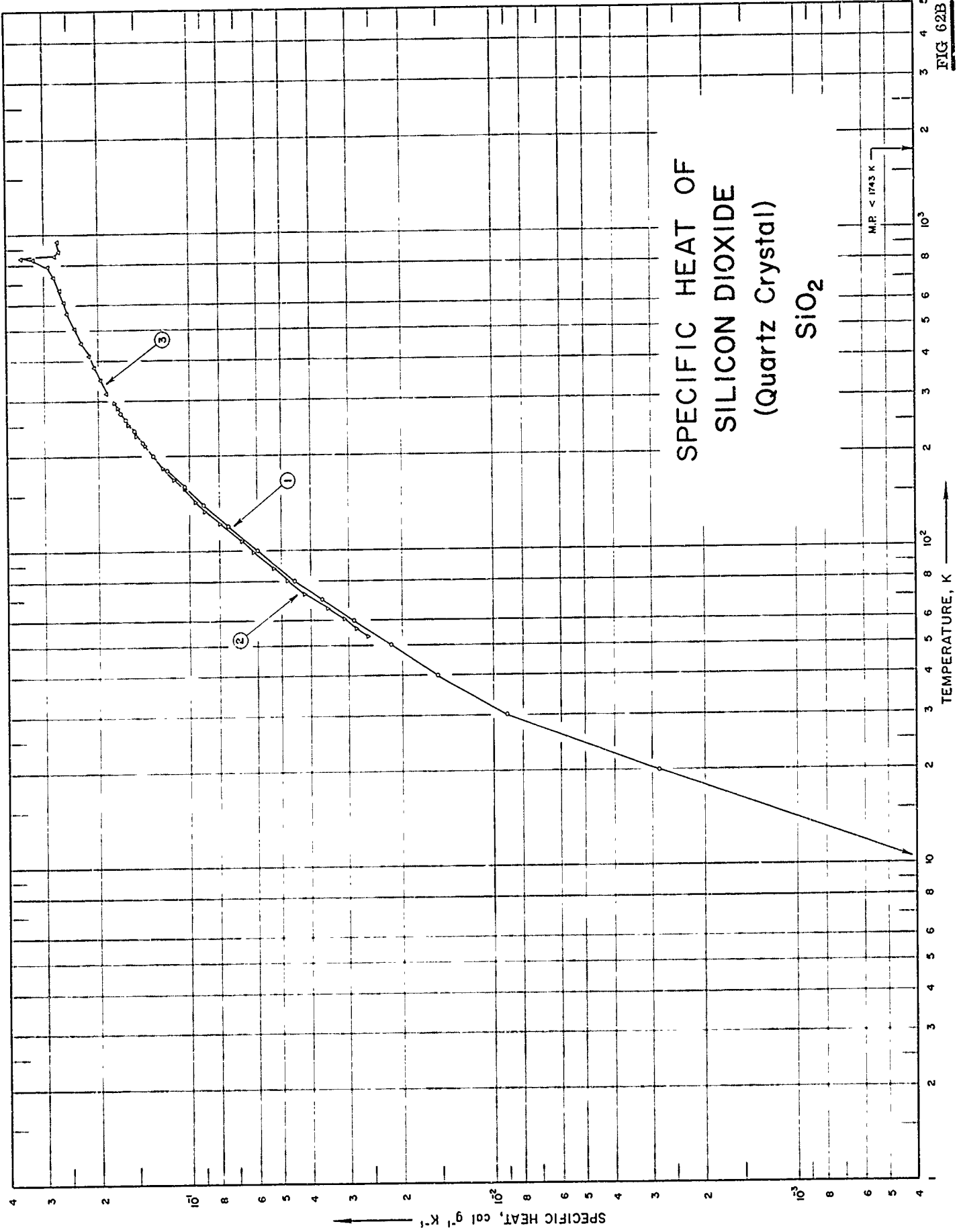

SPECIFICATION TABLE NO. 62-B SPECIFIC HEAT OF SILICON DIOXIDE (Quartz Crystal) SiO_2

[For Data Reported in Figure and Table No. 62-B]

Curve No.	Ref. No.	Year	Temp. Range, K	Reported Error, %	Name and Specimen Designation	Composition (weight percent), Specifications and Remarks
1	119	1921	10-273			99.93 SiO_2 , and 0.07 impurities; α -quartz; density 2.6378 g cm^{-2} at 22.2 C.
2	125	1936	53-296			
3	121	1936	317-949			

DATA TABLE NO. 62-B SPECIFIC HEAT OF SILICON DIOXIDE (Quartz Crystal) SiO₂
 [Temperature, T, K; Specific Heat, C_p, Cal g⁻¹ K⁻¹]

T	C _p	T	C _p
	<u>CURVE 1</u>	<u>CURVE 2</u>	<u>CURVE 3</u>
10	3.66 x 10 ⁻⁴ *	316.65	1.872 x 10 ⁻¹
20	2.83 x 10 ⁻³	334.05	1.925*
30	8.99	348.95	1.960
40	1.53 x 10 ⁻²	367.53	2.011
50	2.17	381.25	2.057*
60	2.87	390.65	2.092*
70	3.66	403.35	2.129*
80	4.50	414.65	2.145
100	5.96	428.95	2.192*
120	7.46	441.15	2.222*
140	8.96	456.35	2.271
160	1.04 x 10 ⁻¹	475.95	2.314*
180	1.18	506.65	2.377*
200	1.31	534.15	2.443*
220	1.42	565.45	2.516
240	1.52	585.25	2.541*
260	1.62	610.35	2.589
273	1.689	640.65	2.634*
	<u>CURVE 2</u>	570.15	2.683
53.4	2.57 x 10 ⁻²	702.95	2.723*
56.4	2.80	732.25	2.791
60.3	3.08	758.55	2.851*
65.4	3.50	777.45	2.912*
72.8	4.17	792.55	2.949
80.0	4.76	808.75	3.036*
87.5	5.27	820.65	3.100*
98.9	6.12	827.25	3.183*
107.9	6.70	834.65	3.271
122.1	7.91	840.65	3.460*
134.1	8.85	844.35	3.610
143.8	9.54	855.05	2.783
156.2	1.035 x 10 ⁻¹	866.55	2.689*
169.1	1.12	883.45	2.698
184.8	1.22	899.95	2.703*
197.7	1.29*	921.05	2.714*
216.1	1.39	949.45	2.721
234.7	1.49		
252.1	1.58		
272.0	1.70*		
285.0	1.72		
296.1	1.76		

* Not shown on plot

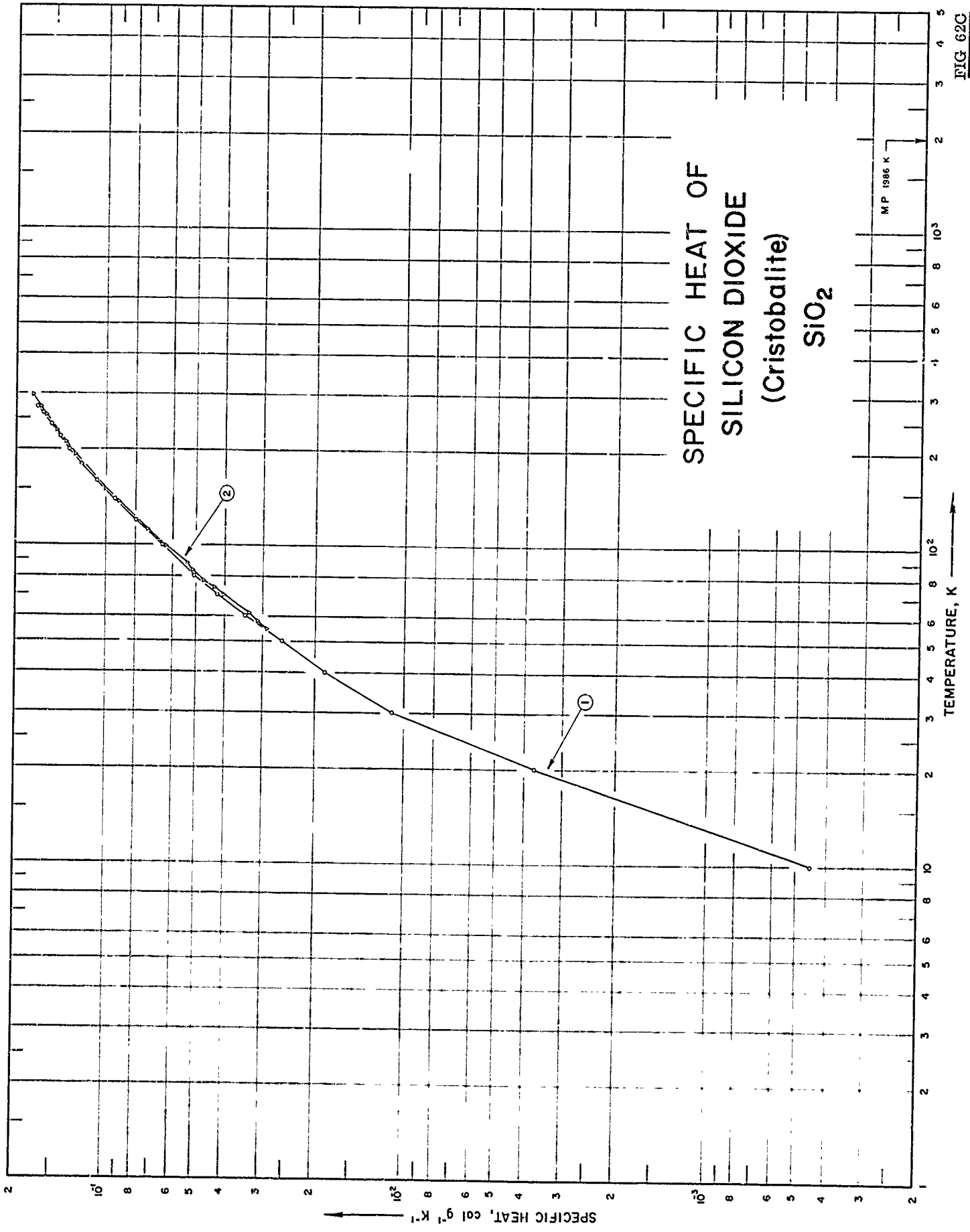

FIG 62C

SPECIFICATION TABLE NO. 62-C SPECIFIC HEAT OF SILICON DIOXIDE (CRISTOBALITE) SiO_2

[For Data Reported in Figure and Table No. 62-C.]

Curve No.	Ref. No.	Year	Temp. Range, K	Reported Error, %	Name and Specimen Designation	Composition (weight percent), Specifications and Remarks
1	119	1921	10-273			
2	125	1936	54-297			99.99 SiO_2 ; cristobalite; density 2.3201 g cm^{-3} at 23.3 C .

DATA TABLE NO. 62-C SPECIFIC HEAT OF SILICON DIOXIDE (CRISTOBALITE) SiO_2
 [Temperature, T, K; Specific Heat, C_p , Cal $\text{g}^{-1} \text{K}^{-1}$]

T	C_p
<u>CURVE 1</u>	
10	4.5×10^{-4}
20	3.7×10^{-3}
30	1.1×10^{-2}
40	1.85
50	2.57
60	3.40
70	4.26
80	5.06
100	6.43
120	7.93
140	9.36
160	1.08×10^{-1}
180	1.21
200	1.34
220	1.44
240	1.54
260	1.64
273	1.709

T	C_p
<u>CURVE 2</u>	
54.8	2.89×10^{-2}
57.8	3.10
61.3	3.33
69.9	4.03
73.7	4.36
77.7	4.71
83.9	5.11
88.0	5.37
99.8	6.31
112.0	7.25
120.4	6.78*
136.8	9.05
150.7	1.005×10^{-1}
164.0	1.09*
178.2	1.18*
193.7	1.27
210.9	1.365
229.5	1.47
241.4	1.525*
257.1	1.595
272.2	1.66
297.2	1.755
297.3	1.77*

* Not shown on plot

FIG 62D

SPECIFIC HEAT OF
SILICON DIOXIDE
(Tridymite)
SiO2

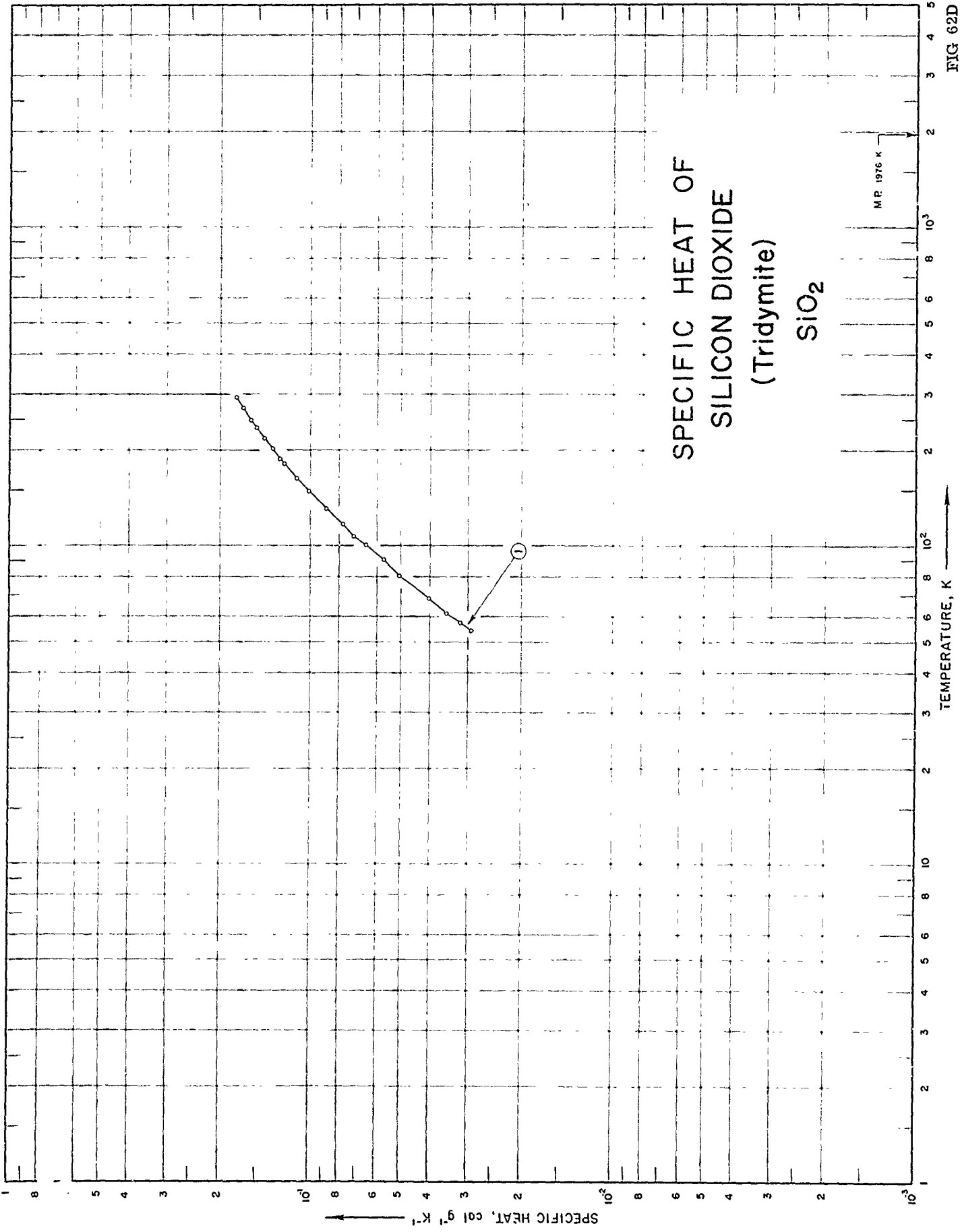

SPECIFICATION TABLE NO. 62-D SPECIFIC HEAT OF SILICON DIOXIDE (TRIDYMIT) SiO_2

[For Data Reported in Figure and Table No. 62-D]

Curve No.	Ref. No.	Year	Temp. Range, K	Reported Error, %	Name and Specimen Designation	Composition (weight percent), Specifications and Remarks
1	125	1936	54-295			99.46 SiO_2 ; tridymite; density 2.2777 g cm^{-3} at 23.7 C .

DATA TABLE NO. 62-D SPECIFIC HEAT OF SILICON DIOXIDE (TRIDYMITHE) SiO_2 [Temperature, T, K; Specific Heat, C_p , Cal g⁻¹ K⁻¹]

T	C_p
	<u>CURVE 1</u>
54.2	2.931×10^{-2}
57.6	3.170
61.5	3.517
68.6	4.003
80.5	5.026
90.8	5.710
100.4	6.563
108.8	7.148
117.7	7.796
131.4	8.836
149.3	1.010×10^{-1}
164.3	1.113
181.6	1.220
187.9	1.258
202.6	1.339
219.5	1.429
235.4	1.515
249.1	1.579
271.8	1.679
278.1	1.704
290.8	1.757
294.9	1.769

 % Not shown on plot

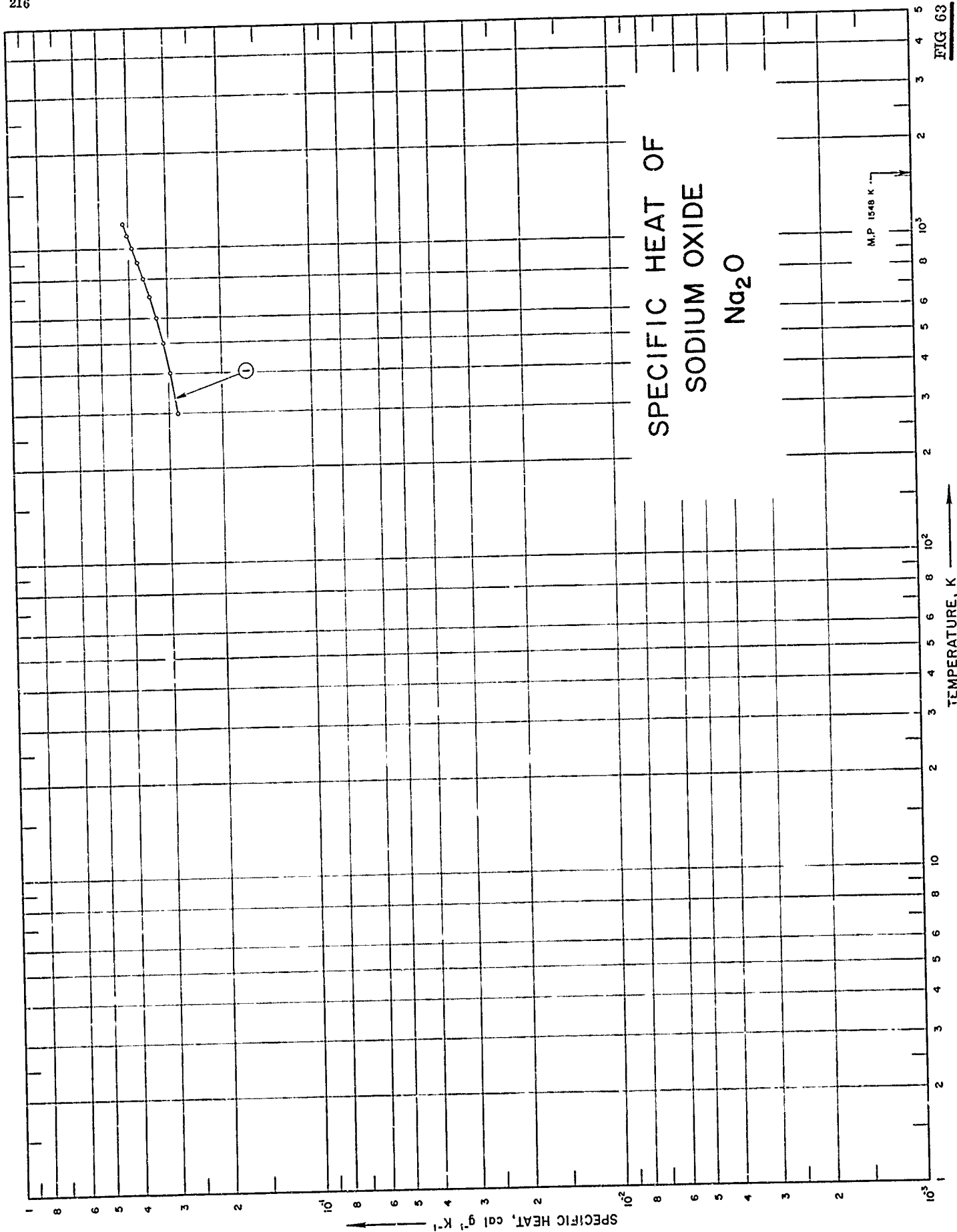

FIG 63

SPECIFICATION TABLE NO. 63 SPECIFIC HEAT OF SODIUM OXIDE Na_2O

[For Data Reported in Figure and Table No. 63]

Curve No.	Ref. No.	Year	Temp. Range, K	Reported Error, %	Name and Specimen Designation	Composition (weight percent), Specifications and Remarks
1	126	1960	298-1170	± 2		96.76 Na_2O , ± 0.33 Na_2CO_3 and 0.91 Na_2O_2 .

DATA TABLE NO. 63 SPECIFIC HEAT OF SODIUM OXIDE, Na_2O
 [Temperature, T, K; Specific Heat, C_p , Cal $\text{g}^{-1}\text{K}^{-1}$]

T	C_p
<u>CURVE 1</u>	
258	2.813×10^{-1}
300	2.816
400	2.976
500	3.135
600	3.294
700	3.454
800	3.613
900	3.772
1000	3.932
1100	4.091
1170	4.203

* Not shown on Plot

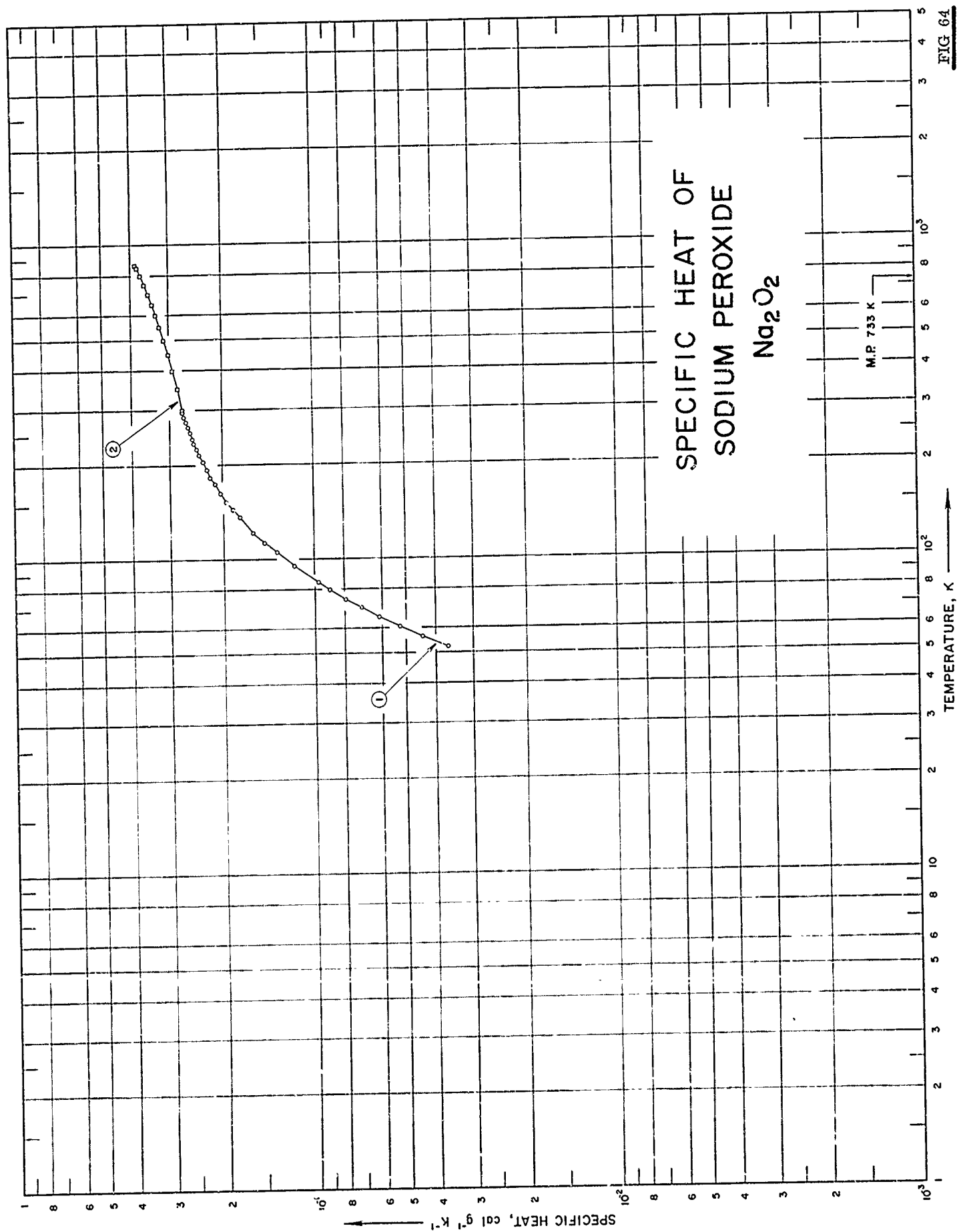

SPECIFICATION TABLE NO. 64 SPECIFIC HEAT OF SODIUM PEROXIDE Na_2O_2

[For Data Reported in Figure and Table No. 64]

Curve No.	Ref. No.	Year	Temp. Range, K	Reported Error, %	Name and Specimen Designation	Composition (weight percent), Specifications and Remarks
1	240	1953	52-298			94.0 Na_2O_2 , 3.6 Na_2O , and 2.4 Na_2CO_3 ; corrected estimates for NaO small.
2	241	1959	298-869			98.3 Na_2O_2 , 1.5 Na_2CO_3 , and 0.2 Na_2O .

DATA TABLE NO. 64 SPECIFIC HEAT OF SODIUM PEROXIDE, Na_2O_2 [Temperature, T, K, Specific Heat, C_p , Cal $\text{g}^{-1}\text{K}^{-1}$]

T	C_p	
	CURVE 1	CURVE 2 (cont.)
52.31	3.654×10^{-2}	3.542×10^{-1}
56.81	4.414	3.642
61.35	5.277	3.742
65.80	6.163	3.842
70.33	7.059	3.890
74.93	7.917	
80.22	8.934	
84.44	9.731	
95.78	1.177×10^{-1}	
106.35	1.349	
114.49	1.475	
123.72	1.607	
137.21	1.776	
145.08	1.864	
154.62	1.960	
164.79	2.054	
175.81	2.149	
184.78	2.212	
195.21	2.269	
205.61	2.344	
215.99	2.405	
225.87	2.458	
235.68	2.501	
244.94	2.532	
255.27	2.586	
265.47	2.626	
275.32	2.662	
285.55	2.703	
296.32	2.726*	
298.16	2.737	
CURVE 2		
298	2.738×10^{-1}	
300	2.742	
350	2.842	
400	2.942	
450	3.042	
500	3.142	
550	3.242	
600	3.342	
650	3.442	

* Not shown on Plot

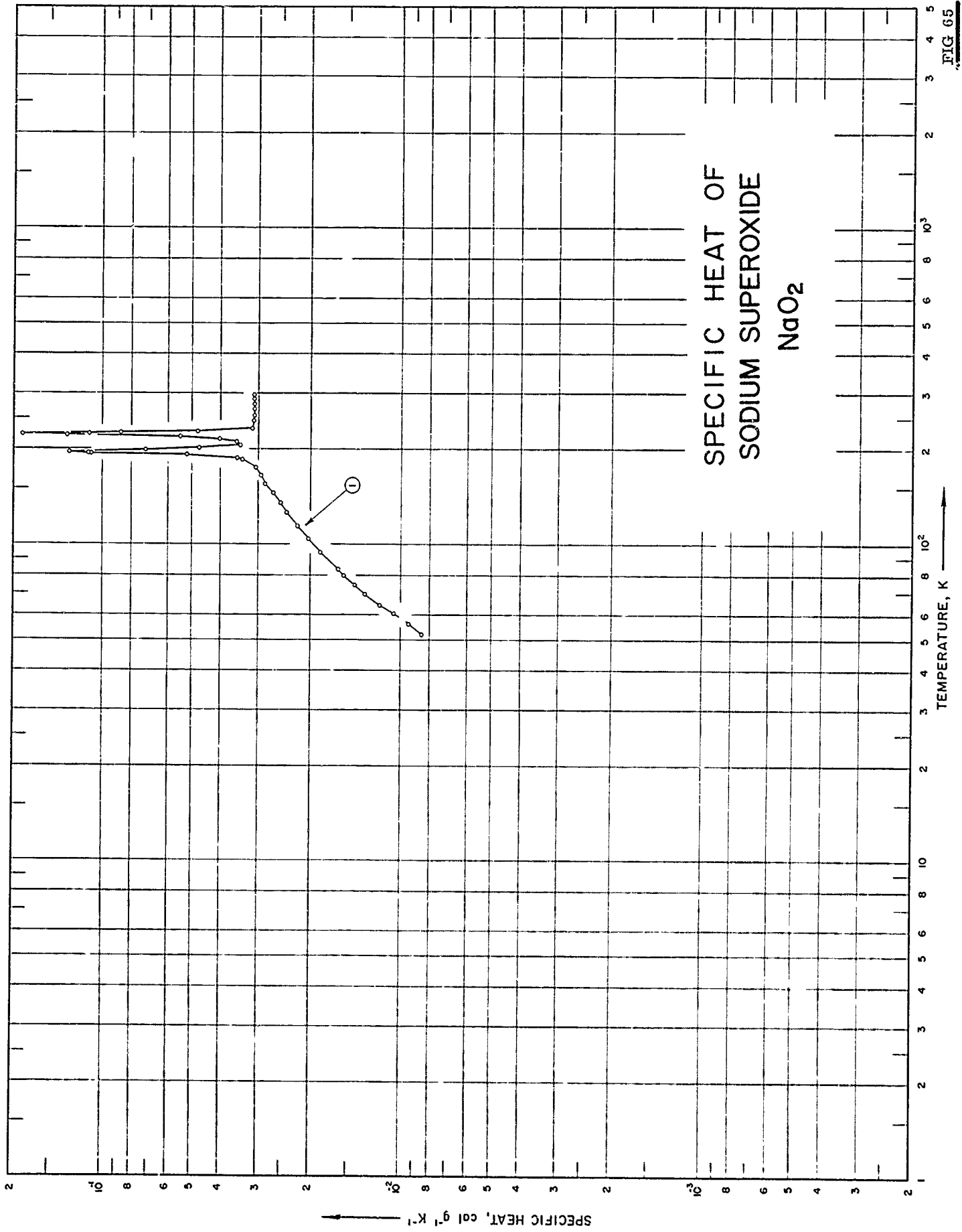

SPECIFICATION TABLE NO. 65 SPECIFIC HEAT OF SODIUM SUPEROXIDE Na_2O_2

[For Data Reported in Figure and Table No. 65]

Curve No.	Ref. No.	Year	Temp. Range, K	Reported Error, %	Name and Specimen Designation	Composition (weight percent), Specifications and Remarks
1	240	1953	52-296			92.5 Na_2O_2 , 6.0 Na_2O , and 1.5 Na_2CO_3 ; corrected for impurities.

DATA TABLE NO. 65 SPECIFIC HEAT OF SODIUM SUPEROXIDE NaO_2 [Temperature, T, K; Specific Heat, C_p , Cal $\text{g}^{-1} \text{K}^{-1}$]

T	C_p
52.13	5.524×10^{-2}
56.02	9.471
60.41	1.067×10^{-1}
64.97	1.196
69.61	1.323
74.36	1.442
79.71	1.563
83.56	1.640
94.46	1.871
104.34	2.056
114.45	2.236
126.97	2.429
135.91	2.558
145.86	2.695
155.74	2.855
165.83	2.957
175.79	3.098
185.70	3.402
187.15	3.540
191.51	5.268
194.23	1.105×10^0
194.38	1.133
196.23	1.316
198.49	7.264×10^{-1}
201.82	4.798
206.02	3.478
206.03	3.458*
210.30	3.584
214.99	3.947*
215.47	4.082
219.11	5.548
221.79	1.341×10^0
223.27	1.882
224.55	1.123
225.02	8.700×10^{-1}
227.98	4.860
232.14	3.184
235.94	3.158*
245.75	3.138
255.89	3.127
266.19	3.129
276.01	3.127
286.26	3.133
296.46	3.133

* Not shown on plot

SPECIFIC HEAT OF STRONTIUM OXIDE SrO

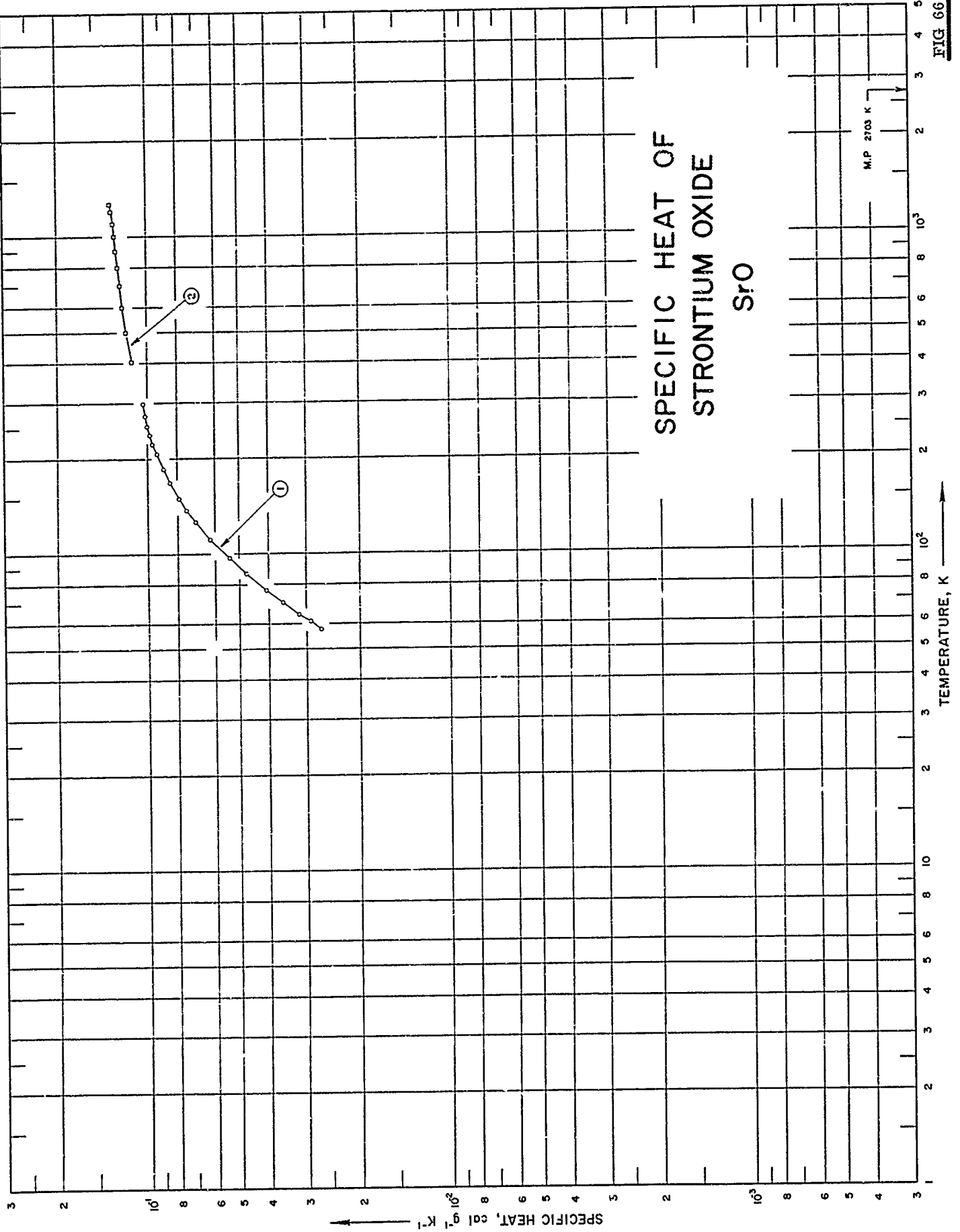

FIG 66

SPECIFICATION TABLE NO. 66 SPECIFIC HEAT OF STRONTIUM OXIDE SrO

[For Data Reported in Figure and Table No. 66]

Curve No.	Ref. No.	Year	Temp. Range, K	Reported Error, %	Name and Specimen Designation	Composition (weight percent), Specifications and Remarks
1	41	1935	58-298			Kahlbaum best grade; impurities mainly carbonate; -14 + 35 mesh size; measured under vacuum.
2	42	1951	405-1265			SrO obtained by thermal decomposition of SrCO ₃ at 1000 C in a vacuum.

DATA TABLE NO. 66 SPECIFIC HEAT OF STRONTIUM OXIDE, SrO
 [Temperature, T, K; Specific Heat, C_p , Cal g⁻¹K⁻¹]

T	C_p
<u>CURVE 1</u>	
57.9	2.680×10^{-2}
61.2	2.897
64.3	3.163
70.0	3.589
76.8	4.071
86.8	4.725
97.1	5.378
111.2	6.219
126.1	6.948
138.4	7.455
149.9	7.890
168.6	8.451
185.3	8.873
207.7	9.307
222.6	9.630
238.3	9.823
254.4	1.002×10^{-1}
273.3	1.016
279.9	1.025*
290.4	1.030*
298.4	1.039
<u>CURVE 2</u>	
495	1.128×10^{-1}
500	1.175
600	1.207
700	1.231
800	1.250
900	1.267
1000	1.282
1100	1.295
1200	1.308
1265	1.317

* Not shown on Plot

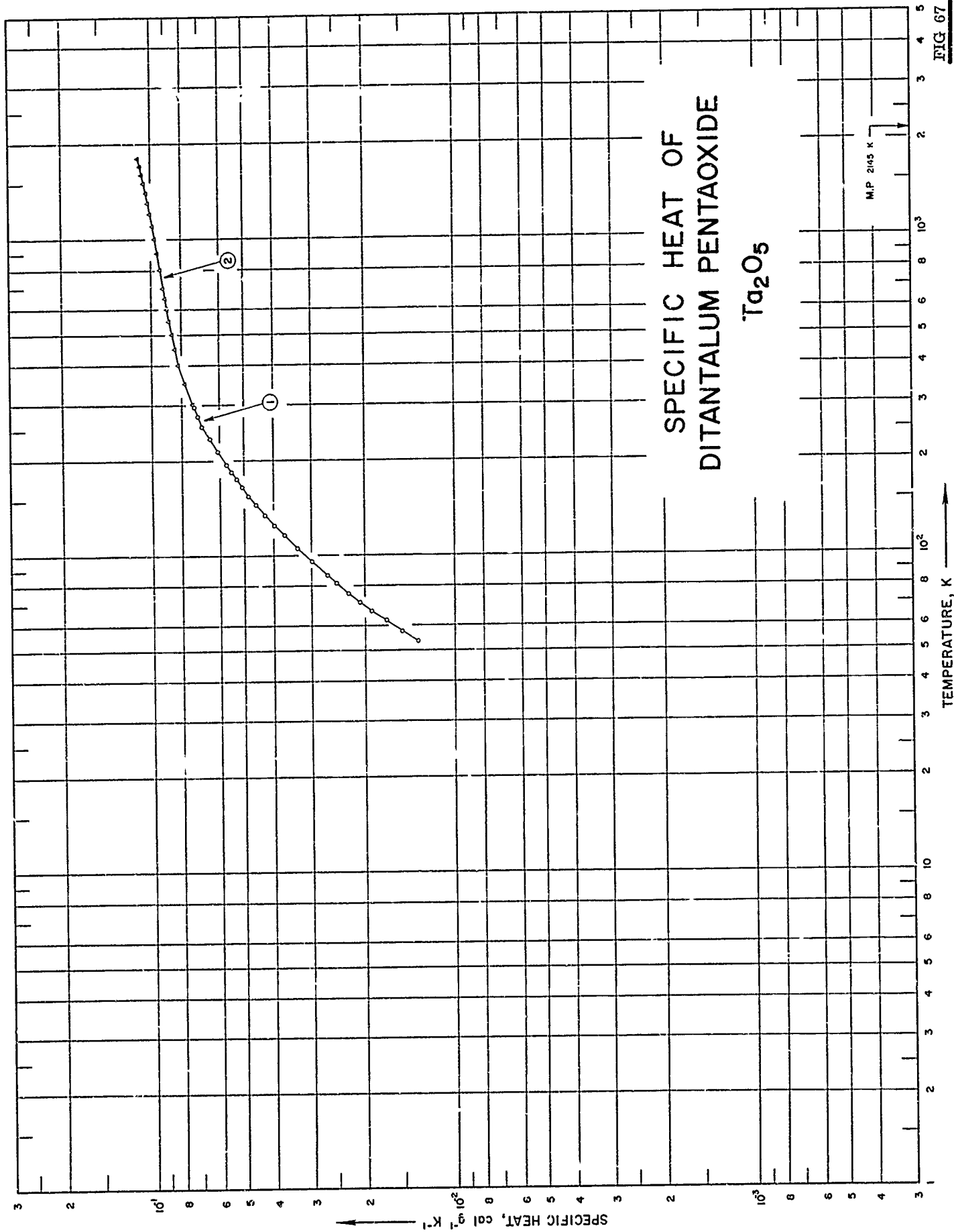

FIG 67

SPECIFICATION TABLE NO. 67 SPECIFIC HEAT OF DITANTALUM PENTAOXIDE Ta_2O_5

[For Data Reported in Figure and Table No. 67]

Curve No.	Ref. No.	Year	Temp. Range, K	Reported Error, %	Name and Specimen Designation	Composition (weight percent), Specifications and Remarks
1	127	1940	53-294			Virtually atomic weight purity; compressed into pellets.
2	114	1953	298-1800	≤0.4		Heated to 1200 C before measurement.

DATA TABLE NO. 67 SPECIFIC HEAT OF DITANTALUM PENTAOXIDE Ti_2O_5 [Temperature, T, K; Specific Heat, C_p , Cal $g^{-1}K^{-1}$]

T	C_p	CURVE 2 (cont.)	
		T	C_p
53.4	1.329×10^{-2}	800	9.351×10^{-2}
57.6	1.499	850	9.449*
62.1	1.693	900	9.544
66.6	1.891	950	9.635*
70.9	2.069	1000	9.724
75.4	2.257	1050	9.810*
81.5	2.474	1100	9.895
86.2	2.648	1150	9.979*
95.6	2.970	1200	1.006×10^{-1}
105.3	3.328	1250	1.014*
115.7	3.665	1300	1.022
124.9	3.959	1350	1.030*
134.9	4.269	1400	1.038
145.0	4.550	1450	1.046*
154.7	4.806	1500	1.054*
165.0	5.055	1550	1.062
174.6	5.283	1600	1.070
184.4	5.498	1650	1.077*
194.5	5.704	1700	1.085
203.4	5.895*	1750	1.093*
214.2	6.085	1800	1.100
224.5	6.273*		
234.7	6.461		
245.2	6.642*		
255.8	6.825*		
265.8	6.934*		
275.5	7.049		
285.0	7.189*		
294.2	7.266		

CURVE 2	
T	C_p
298	7.307×10^{-2} *
300	7.330
350	7.799
400	8.130
450	8.380
500	8.579
550	8.747
600	8.892
650	9.021
700	9.139
750	9.248

* Not shown on Plot

SPECIFIC HEAT OF TELLURIUM DIOXIDE TeO₂

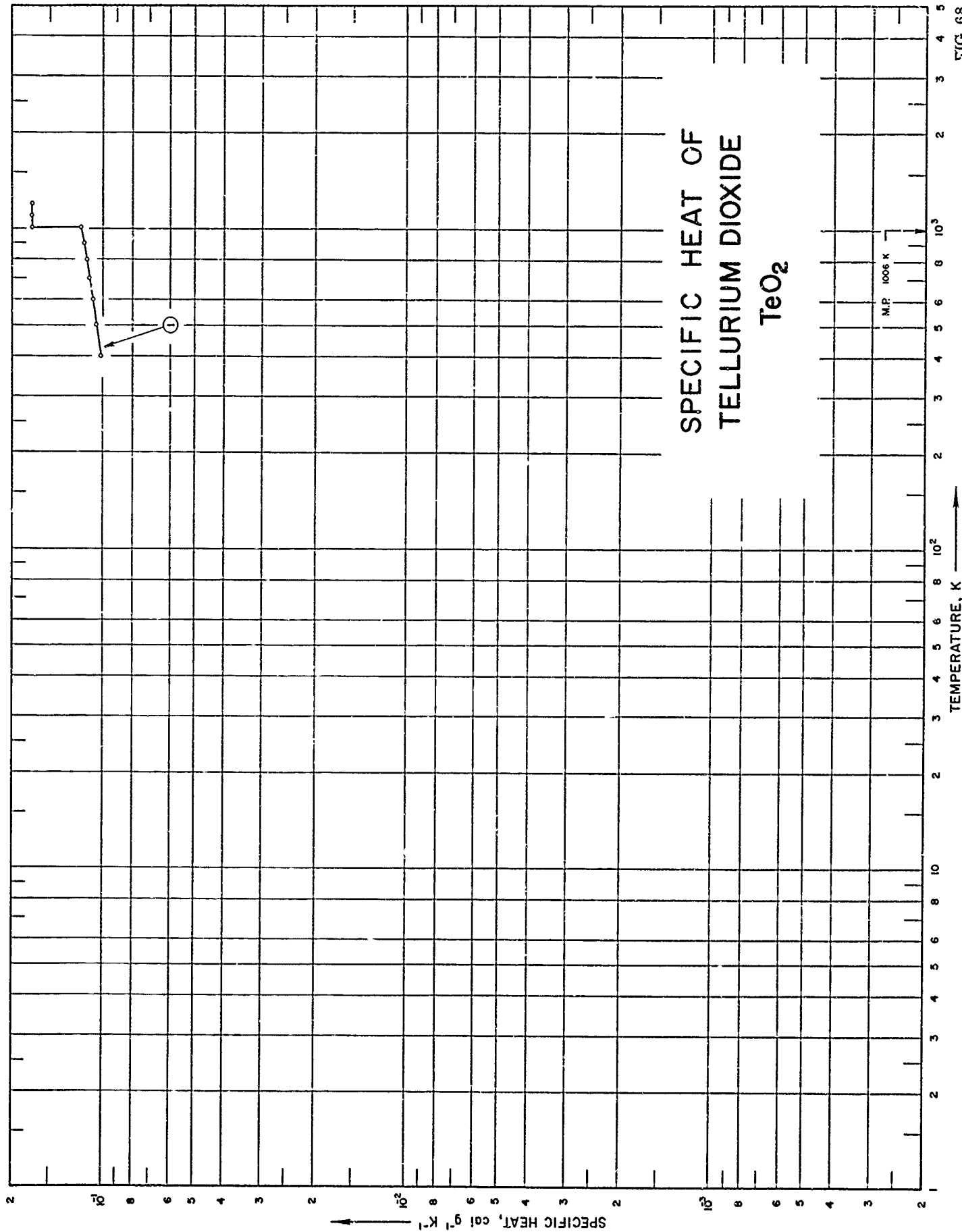

SPECIFICATION TABLE NO. 68 SPECIFIC HEAT OF TELLURIUM DIOXIDE TeO_2

[For Data Reported in Figure and Table No. 68]

Curve No.	Ref. No.	Year	Temp. Range, K	Reported Error, %	Name and Specimen Designation	Composition (weight percent), Specifications and Remarks
1	128	1962	400-1200	0.5		Spectroscopically pure with only traces of Ag, Ca, Na, Si, Mn; supplied by the Johnson, Matthey Co., Ltd.; sealed under argon atmosphere.

DATA TABLE NO. 68 SPECIFIC HEAT OF TELLURUM DIOXIDE, TeO_2
 [Temperature, T, K; Specific Heat, C_p , Cal $\text{g}^{-1}\text{K}^{-1}$]

T	C_p
CURVE 1	
400	1.016 x 10^{-1}
500	1.055
600	1.086
700	1.113
800	1.138
900	1.163*
1000	1.187*
1006.16	1.188
1006.16	1.719
1100	1.722
1200	1.726

* Not shown on Plot

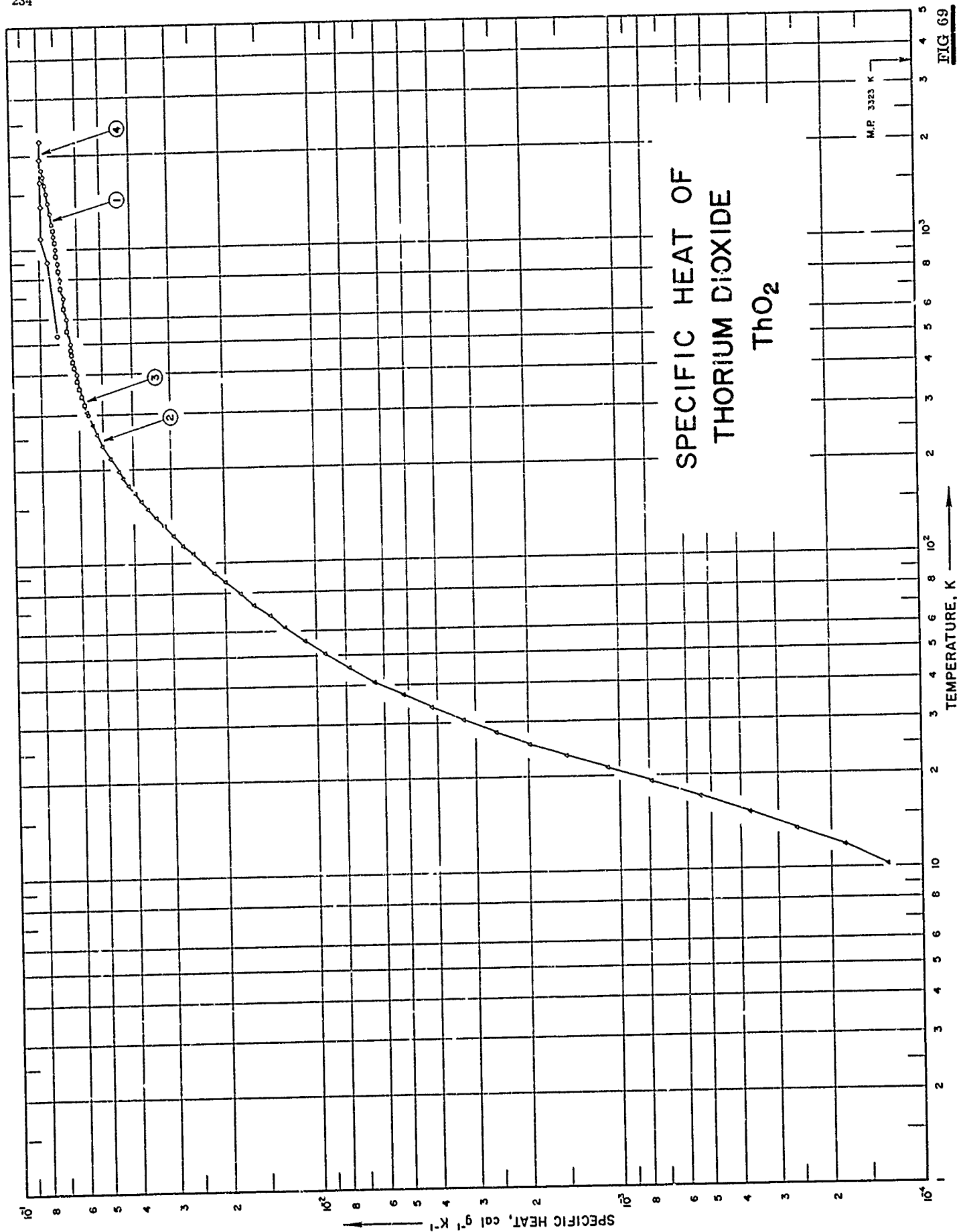

FIG 69

SPECIFICATION TABLE NO. 69 SPECIFIC HEAT OF THORIUM DIOXIDE ThO₂

[For Data Reported in Figure and Table No. 69]

Curve No.	Ref. No.	Year	Temp. Range, K	Reported Error, %	Name and Specimen Designation	Composition (weight percent), Specifications and Remarks
1	122	1941	299-1790	0.5		99.28 ThO ₂ , 0.26 common metals, 0.46 rare earth.
2	129, 130	1953	10-305			Thoria ThO ₂ , 0.015 max. rare earth, 0.005 each Al, Si, 0.004 La, and <0.005 others.
3	131	1961	298-1200	0.3-0.5	Sample 1	99.95 ThO ₂ , 0.01 Al, 0.005 Ca, 0.005 Cu, 0.004 Fe, <0.001 B, and <0.0005 Cr; supplied by the Lindsay Chemical Co; pressed; fired; sintered; density 605 lb ft ⁻³ .
4	48	1962	533-2200	≤5.0		Sample supplied by Zirconium Corp. of America; crushed in hardened steel mortar to pass 100-mesh screen, pressed and sintered; density at 25 C, before exposure: apparent density (ASTM method B311-58) 568 lb ft ⁻³ , true density (by immersion in xylene) 604 lb ft ⁻³ .

DATA TABLE NO. 69 SPECIFIC HEAT OF THORIUM DIOXIDE, ThO₂
 [Temperature, T, K; Specific Heat, C_p, Cal g⁻¹K⁻¹]

T	C _p	T	C _p	T	C _p
<u>CURVE 1</u>					
298.15	5.588 × 10 ⁻²	61.39	1.263 × 10 ⁻² *	480	6.370 × 10 ⁻²
300	5.501*	67.11	1.453*	500	6.423*
400	6.081	74.95	1.658*	550	6.522
500	6.351	84.37	1.932	600	6.605*
600	6.538	92.34	2.157	650	6.681*
700	6.686	99.61	2.355	700	6.745
800	6.813	106.97	2.554	750	6.806
900	6.928	114.43	2.752	800	6.859*
1000	7.036	122.30	2.955	850	6.912
1100	7.139	130.77	3.165	900	6.957*
1200	7.238	139.55	3.378	950	7.007
1300	7.335	148.37	3.577	1000	7.048*
1400	7.430	157.30	3.770	1050	7.094
1500	7.525	166.27	3.949	1100	7.135*
1600	7.618	175.73	4.127	1150	7.177*
1700	7.710	185.75	4.301	1200	7.215*
1790	7.793	195.89	4.468	<u>CURVE 4</u>	
<u>CURVE 2</u>					
10.19	1.3 × 10 ⁻⁴	185.66	4.297*	533.15	7.0 × 10 ⁻²
11.85	1.8	195.64	4.460	810.93	7.5
13.44	2.6	205.69	4.615*	1088.71	7.9
15.15	3.7	215.83	4.755	1366.48	7.9
17.09	5.76	226.06	4.888*	1644.26	7.9
19.14	7.84	236.26	5.013	1922.04	7.9
21.18	1.09 × 10 ⁻³	246.35	5.148*	2199.82	7.9
23.27	1.97	256.45	5.229	<u>CURVE 3</u>	
25.46	2.55	266.58	5.327*	298.15	5.590 × 10 ⁻² *
27.83	3.28	276.62	5.418*	300	5.609
30.52	4.161	286.58	5.501*	320	5.749
33.59	5.183	296.52	5.577*	340	5.870
37.00	6.410	305.40	5.645	360	5.973
40.93	7.803	<u>CURVE 3</u>			
45.48	9.352	298.15	5.590 × 10 ⁻² *	380	6.060
55.86	1.097 × 10 ⁻²	300	5.609	400	6.139*
61.63	1.271*	320	5.749	420	6.207
61.43	1.265*	340	5.870	440	6.268
67.15	1.433	360	5.973	460	6.325
72.93	1.602	380	6.060		
79.41	1.788	400	6.139*		
86.35	1.990	420	6.207		
		440	6.268		
		460	6.325		

* Not shown on Plot

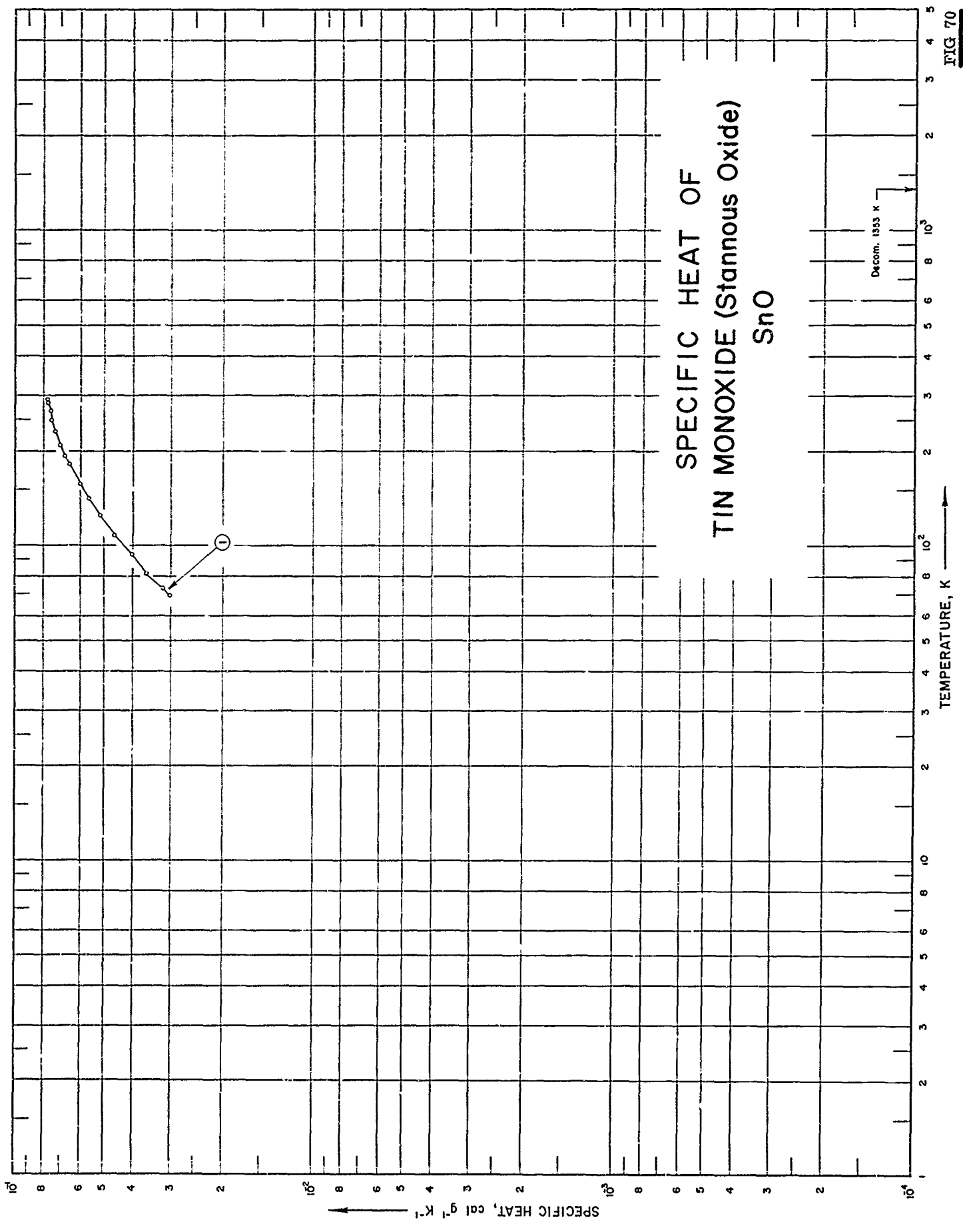

FIG. 70

SPECIFICATION TABLE NO. 70 SPECIFIC HEAT OF TIN MONOXIDE (STANNOUS OXIDE) SnO

[For Data Reported in Figure and Table No. 70]

Curve No.	Ref. No.	Year	Temp. Range, K	Reported Error, %	Name and Specimen Designation	Composition (weight percent), Specifications and Remarks
1	132	1929	69-292			98.0 SnO; prepared by precipitation of Sn(OH) ₂ with ammonia from a boiling solution of pure SnCl ₂ .

DATA TABLE NO. 70 SPECIFIC HEAT OF TIN MONOXIDE (STANNOUS OXIDE), SnO

[Temperature, T K; Specific Heat, C_p , Cal g⁻¹K⁻¹]

T	C_p
<u>CURVE 1</u>	
69.6	3.019 x 10 ⁻²
73.0	3.192
81.7	3.645
93.3	4.033
108.1	4.641
125.0	5.178
140.8	5.638
156.9	6.047
181.7	6.575
193.5	6.809
209.7	7.079
230.2	7.362
251.3	7.550
268.3	7.602
284.3	7.803
292.5	7.810

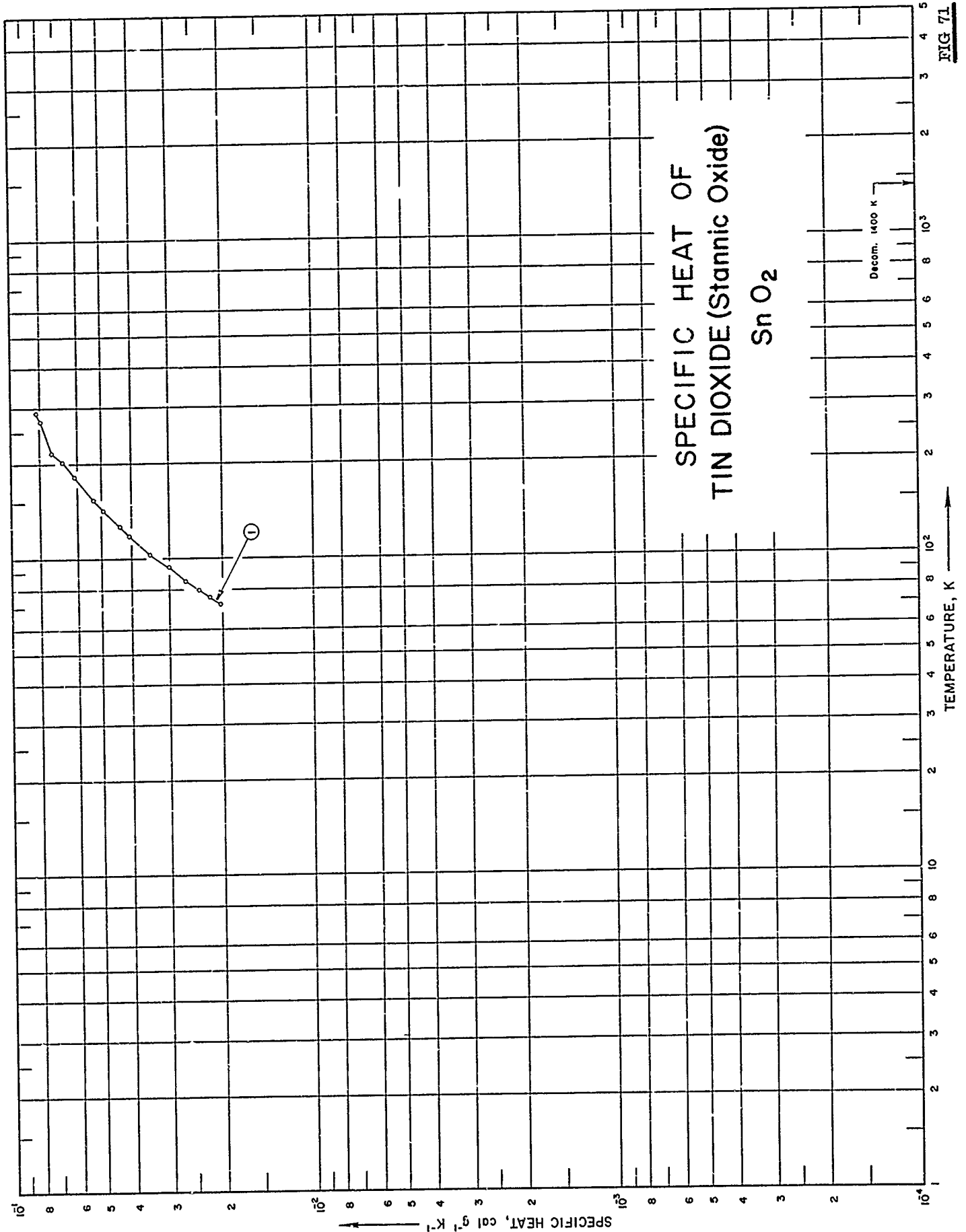

FIG. 71

SPECIFICATION TABLE NO. 71 SPECIFIC HEAT OF TIN DIOXIDE (STANNIC OXIDE) SnO₂

[For Data Reported in Figure and Table No. 71]

Curve No.	Ref. No.	Year	Temp. Range, K	Reported Error, %	Name and Specimen Designation	Composition (weight percent), Specifications and Remarks
1	132	1929	72-289			> 99.0 SnO ₂ , prepared by action of dilute HNO ₃ on pure electrolytic tin.

DATA TABLE NO. 71 SPECIFIC HEAT OF TIN DIOXIDE (STANNIC OXIDE), SnO_2
 [Temperature, T, K; Specific Heat, C_p , $\text{Cal g}^{-1}\text{K}^{-1}$]

T	C_p
CURVE 1	
71.8	2.048×10^{-2}
75.2	2.205
79.3	2.401
84.8	2.651
93.8	3.007
103.6	3.478
118.2	4.091
125.0	4.393
124.2	4.938
154.6	5.377
181.8	6.184
202.7	6.755
215.5	7.332
271.6	7.976*
273.4	8.062*
287.2	8.162*
289.4	8.235

* Not shown on Plot

FIG 72

SPECIFIC HEAT OF TITANIUM MONOXIDE

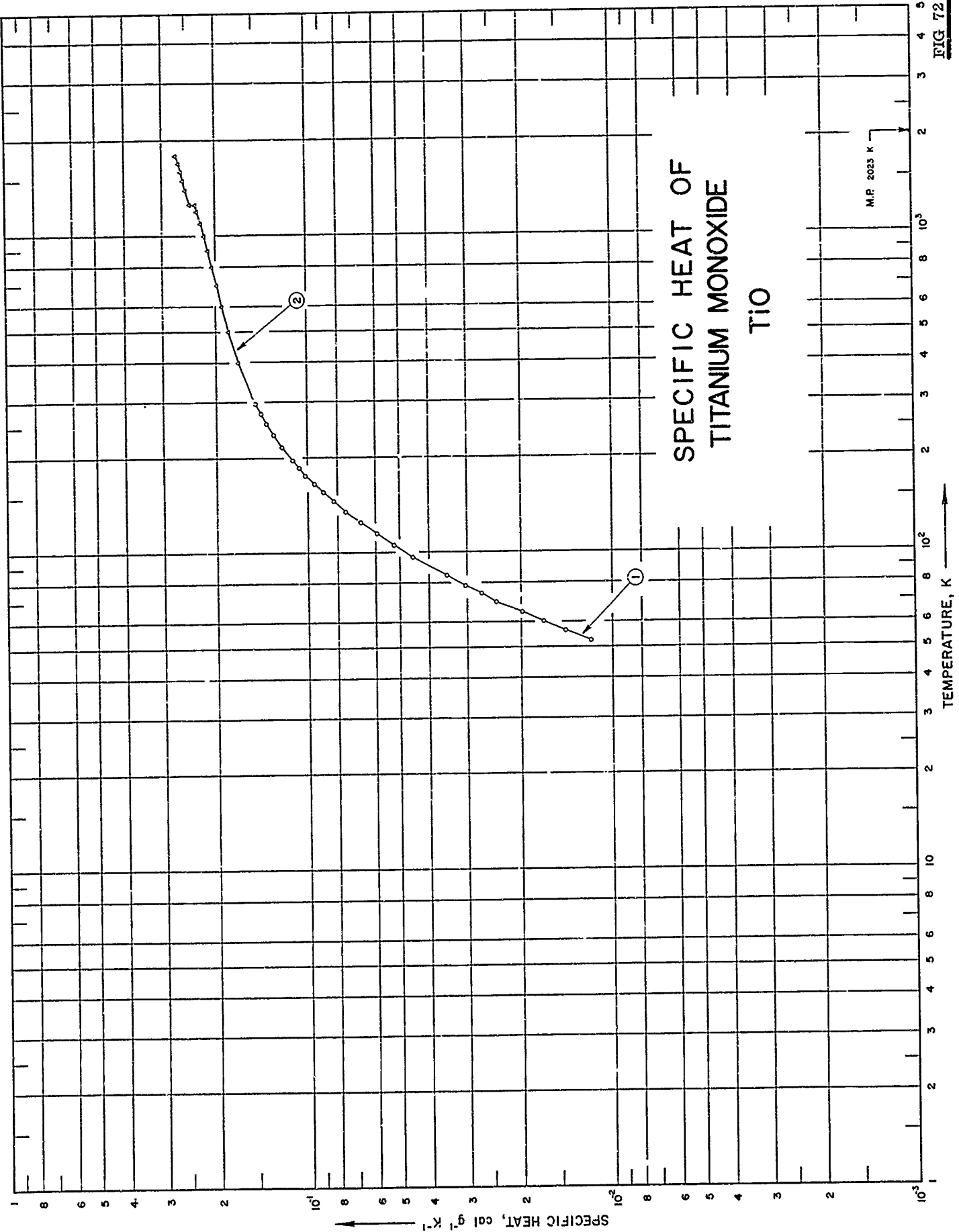

SPECIFIC HEAT, cal g⁻¹ K⁻¹

TEMPERATURE, K

SPECIFICATION TABLE NO. 72 SPECIFIC HEAT OF TITANIUM MONOXIDE TiO

[For Data Reported in Figure and Table No. 72]

Curve No.	Ref. No.	Year	Temp. Range, K	Reported Error, %	Name and Specimen Designation	Composition (weight percent), Specifications and Remarks
1	133	1946	53-296			99.2 TiO, 0.7 Si, and 0.1 Ti.
2	134	1946	298-1800	1		99.2 TiO, 0.1 TiC, and 0.7 Si; measured in helium atmosphere.

DATA TABLE NO. 72 SPECIFIC HEAT OF TITANIUM MONOXIDE, TiO

[Temperature, T, K; Specific Heat, C_p, Cal g⁻¹K⁻¹]

T	CURVE 1		T	CURVE 2 (cont.)	
	C _p	10 ⁻²		C _p	10 ⁻¹
52.6	1.18	1.8	β1264	2.448	2.448
56.7	1.43		1300	2.465	2.465
60.6	1.690		1400	2.512	2.512
64.8	1.989		1500	2.559	2.559
69.7	2.410		1600	2.606	2.606
74.2	2.704		1700	2.652	2.652
78.6	3.049		β1800	2.700	2.700
84.5	3.518				
96.9	4.516				
105.7	5.228				
115.1	5.977				
125.1	6.759				
135.1	7.510				
145.8	8.268				
155.4	8.925				
165.5	9.565				
176.2	1.021	10 ⁻¹			
185.9	1.075				
196.3	1.128				
205.8	1.177*				
215.8	1.222*				
226.1	1.264*				
235.8	1.300*				
246.2	1.337*				
256.2	1.375*				
266.2	1.406*				
276.2	1.434*				
286.1	1.462*				
296.3	1.490*				

CURVE 2	
α298.15	1.495 × 10 ⁻¹ *
300	1.499*
400	1.698
500	1.820
600	1.912
700	1.989
800	2.059
900	2.125
1000	2.188
1100	2.250
1200	2.309
α1264	2.347

* Not shown on Plot

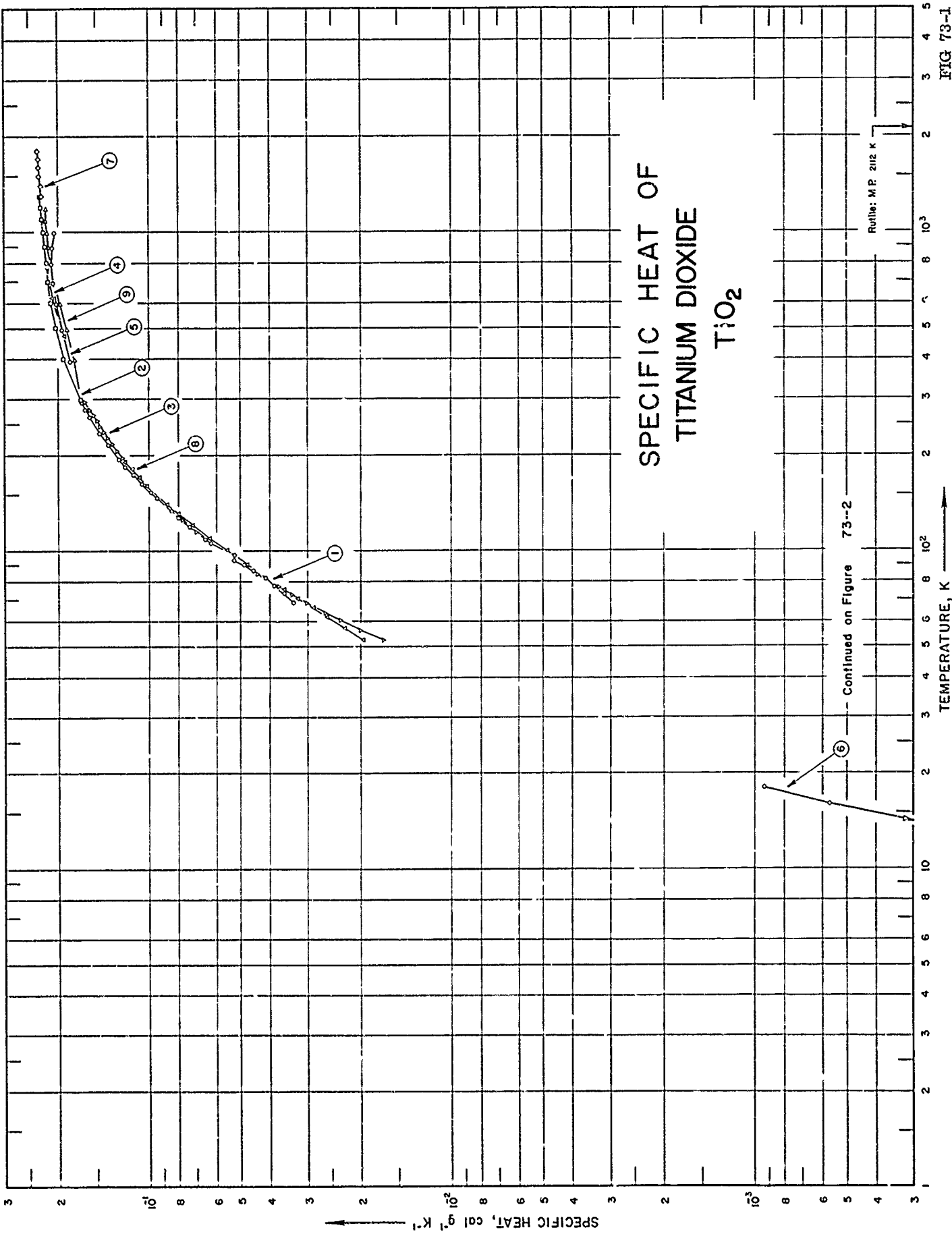
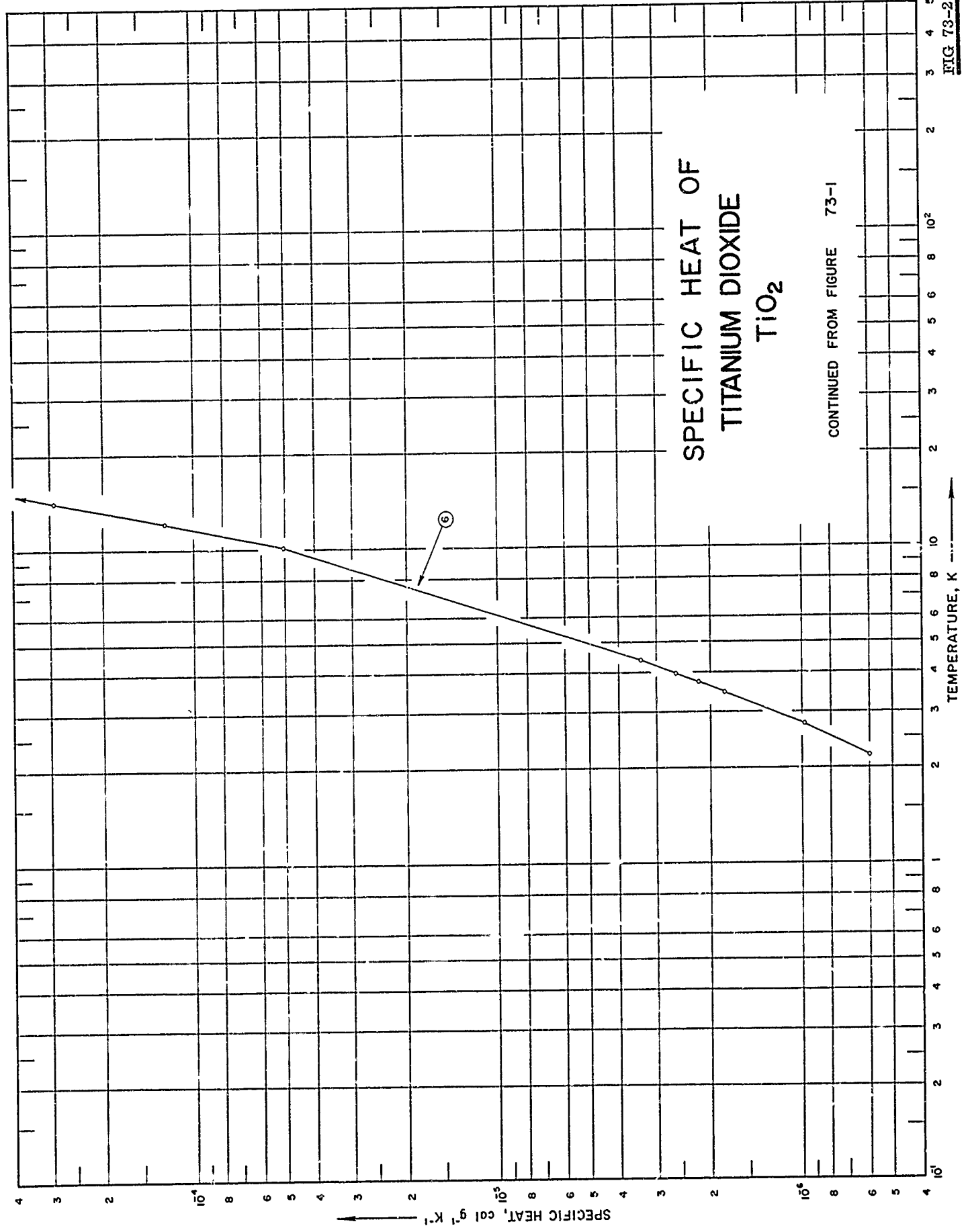

FIG 73-1

FIG 73-2



SPECIFICATION TABLE NO. 73 SPECIFIC HEAT OF TITANIUM DIOXIDE TiO_2

[For Data Reported in Figure and Table No. 73]

Curve No.	Ref. No.	Year	Temp. Range, K	Reported Error, %	Name and Specimen Designation	Composition (weight percent), Specifications and Remarks
1	135	1939	69-295			< 0.4 SiO_2 ; powdered, pressed into pellets.
2	134	1946	298-1300	0.5	Anatase	99.0% TiO_2 , 0.30 SiO_2 , 0.15 CaO , and 0.07 others; dried 4 hrs at 1050 C.
3	136	1947	53-298	± 0.3	Anatase	99.3 TiO_2 and 0.3 H_2O ; density 242 lb ft ⁻³ ; corrected for H_2O .
4	92	1950	473-773		Anatase	Doubtful accuracy.
5	137	1956	393-993			X-ray showed only lines of anatase; synthetically prepared from doubly distilled TiCl_4 , heated 4 hrs at 585 C; density 243.7 lb ft ⁻³ .
6	138	1958	2-18		Rutile	Transparent, but slightly yellow.
7	134	1946	298-1800	0.2	Rutile	97.90 TiO_2 , 0.55 ZrO_2 , 0.5 SiO_2 , 0.27 V_2O_5 , 0.15 CaO , 0.15 Fe_2O_3 , 0.12 Al_2O_3 , and 0.10 others.
8	136	1947	53-298	± 0.3	Rutile	99.7 TiO_2 ; density 265 lb ft ⁻³ .
9	137	1956	293-1193		Rutile	X-ray showed no lines of anatase; white with slight yellow cast; synthetically prepared from doubly distilled TiCl_4 ; heated 1.5 hrs at 930 C; density 259.1 lb ft ⁻³ .

DATA TABLE NO. 73 SPECIFIC HEAT OF TITANIUM DIOXIDE, TiO₂[Temperature, T, K; Specific Heat, C_p, Cal g⁻¹K⁻¹]

T	C _p	T	C _p	T	C _p	T	C _p		
CURVE 1									
Series 1									
85.40	4.46 × 10 ⁻² *	400	1.926 × 10 ⁻¹	473	1.91 × 10 ⁻¹	1600	2.324 × 10 ⁻¹		
89.15	4.84 × 10 ⁻² *	500	2.042	623	2.10	1700	2.338		
93.23	5.26 × 10 ⁻² *	600	2.110	773	2.18	1800	2.352		
106.02	6.31 × 10 ⁻² *	700	2.156	CURVE 5					
112.99	6.67 × 10 ⁻² *	800	2.191	393	1.837 × 10 ⁻¹	CURVE 8			
119.50	7.35 × 10 ⁻² *	900	2.219	493	1.949	52.5	1.967 × 10 ⁻²		
128.35	8.01 × 10 ⁻² *	1000	2.244	593	2.034	57.0	2.260		
137.52	8.76 × 10 ⁻² *	1100	2.265	693	2.086	61.9	2.594		
153.80	9.87 × 10 ⁻² *	1200	2.285	793	2.108	66.0	2.887		
163.53	1.06 × 10 ⁻¹ *	1300	2.303	893	2.099	70.8	3.247		
174.28	1.13 × 10 ⁻¹ *	CURVE 3						75.4	3.596
184.34	1.20 × 10 ⁻¹ *	52.5	1.683 × 10 ⁻²	993	2.060	79.5	3.914*		
194.77	1.26 × 10 ⁻¹ *	56.2	2.000	CURVE 6				90.5	4.775
215.08	1.37 × 10 ⁻¹ *	60.1	2.340	2.16	5.982 × 10 ⁻⁷	100.1	5.554		
224.70	1.4 × 10 ⁻¹ *	63.9	2.638	2.72	9.570	109.7	6.340		
234.22	1.46 × 10 ⁻¹ *	68.7	3.024	3.42	1.795 × 10 ⁻⁶	120.2	7.184		
244.20	1.50 × 10 ⁻¹ *	72.9	3.383	3.69	2.183	130.5	8.065		
264.22	1.58 × 10 ⁻¹ *	77.2	3.748	3.92	2.602	140.4	8.766*		
274.23	1.62 × 10 ⁻¹ *	84.8	4.402	4.31	3.380	150.7	9.516*		
295.07	1.68 × 10 ⁻¹ *	95.2	5.330*	4.31	3.380	160.7	1.022 × 10 ⁻¹		
Series 2									
68.78	3.34 × 10 ⁻²	104.5	6.125	10.0	5.085 × 10 ⁻⁵	170.6	1.086		
73.06	3.57 × 10 ⁻²	115.2	6.992	12.0	1.256 × 10 ⁻⁴	180.7	1.150		
77.80	3.87 × 10 ⁻²	125.3	7.772*	14.0	2.931	189.9	1.208		
82.10	4.12 × 10 ⁻²	134.9	8.479*	16.0	5.683	201.1	1.263*		
86.13	4.51 × 10 ⁻²	145.7	9.229*	18.0	9.332	211.2	1.317*		
90.05	4.87 × 10 ⁻²	155.5	9.905*	CURVE 7					
94.32	5.24 × 10 ⁻²	165.6	1.119 × 10 ⁻¹ *	298.15	1.688 × 10 ⁻¹ *	231.1	1.406*		
105.60	6.27 × 10 ⁻²	175.6	1.174*	300	1.695*	240.9	1.447*		
109.69	6.52 × 10 ⁻²	185.6	1.230*	400	1.920*	251.1	1.491*		
134.65	8.42 × 10 ⁻²	195.9	1.283*	500	2.031*	261.3	1.529*		
146.68	9.42 × 10 ⁻²	216.3	1.337*	600	2.098*	271.1	1.564*		
277.09	1.656 × 10 ⁻¹ *	226.3	1.377*	700	2.142*	281.0	1.597*		
286.40	1.656 × 10 ⁻¹ *	235.8	1.421*	800	2.174*	290.7	1.627*		
291.90	1.672 × 10 ⁻¹ *	246.2	1.458*	900	2.201*	297.7	1.645*		
CURVE 2									
298.15	1.688 × 10 ⁻¹ *	256.1	1.498*	1000	2.224*	298.16	1.647*		
300	1.695 × 10 ⁻¹ *	266.3	1.533*	1100	2.244*	CURVE 9			
Series 3									
298.15	1.688 × 10 ⁻¹ *	276.5	1.579*	293	1.681 × 10 ⁻¹ *	793	2.116 × 10 ⁻¹ *		
300	1.695 × 10 ⁻¹ *	286.0	1.612*	393	1.778	893	2.160		
Series 4									
298.15	1.688 × 10 ⁻¹ *	295.8	1.648*	493	1.866	993	2.190		
300	1.695 × 10 ⁻¹ *	298.16	1.654*	593	1.979*	1093	2.204		
Series 5									
298.15	1.688 × 10 ⁻¹ *	298.16	1.654*	693	2.056	1193	2.203		

* Not shown on Plot

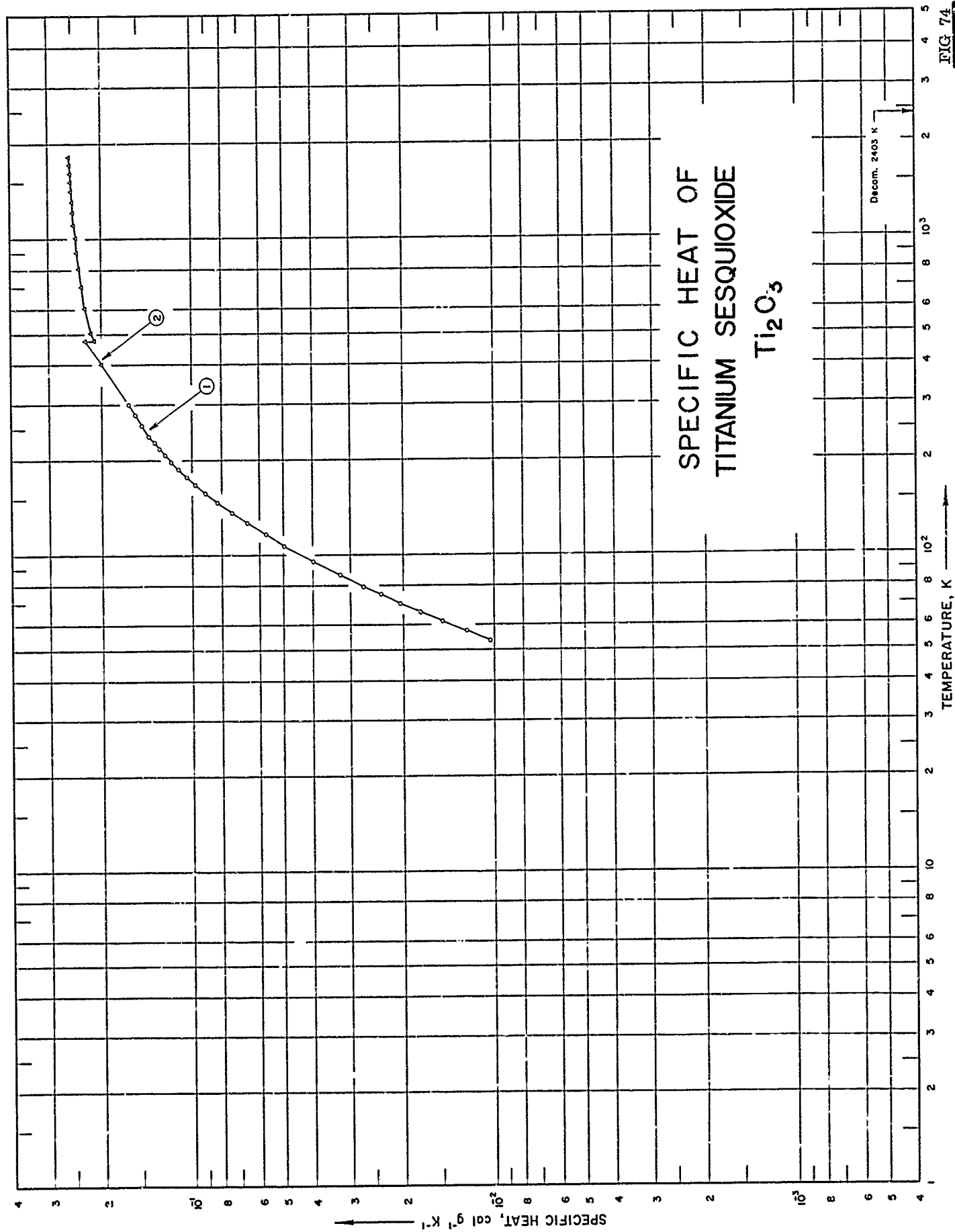

FIG 74

SPECIFICATION TABLE NO. 74 SPECIFIC HEAT OF TITANIUM SESQUIOXIDE Ti_2O_3

[For Data Reported in Figure and Table No. 74]

Curve No.	Ref. No.	Year	Temp. Range, K	Reported Error, %	Name and Specimen Designation	Composition (weight percent), Specifications and Remarks
1	133	1946	53-298			99.4 Ti_2O_3 , 0.3 SiO_2 , and 0.3 TiC .
2	134	1946	298-1800	0.2-1.5		99.4 Ti_2O_3 , 0.3 TiC , and 0.3 SiO_2 ; prepared from finely ground reaction mixture of C and TiO_2 by heating 20 hrs at 1400 C.

DATA TABLE NO. 74 SPECIFIC HEAT OF TITANIUM SESQUIOXIDE, Ti_2O_3
 [Temperature, T, K; Specific Heat, C_p , Cal $g^{-1}K^{-1}$]

T	C_p	T	C_p
CURVE 1		CURVE 2 (cont.)	
53.0	1.023×10^{-2}	800	2.373×10^{-1}
57.0	1.234	900	2.405
61.1	1.481	1000	2.431
65.4	1.750	1100	2.453
69.7	2.039	1200	2.471
74.3	2.361	1300	2.487
78.8	2.693	1400	2.502
85.6	3.215	1500	2.516
94.8	3.951	1600	2.529
106.4	4.924	1700	2.541
115.2	5.680	1800	2.553
125.2	6.524		
135.2	7.357		
145.6	8.198		
155.5	8.985		
165.5	9.722		
175.6	1.045×10^{-1}		
185.6	1.109		
195.9	1.173		
205.9	1.234		
216.2	1.292		
226.2	1.344		
235.7	1.399		
235.8	1.461*		
240.3	1.437*		
244.7	1.430*		
246.2	1.433*		
256.0	1.470*		
266.1	1.507*		
276.2	1.545*		
286.1	1.579*		
296.4	1.612*		
298.16	1.618		
CURVE 2			
α 298.15	1.618×10^{-1} *		
300	1.624*		
400	1.997		
ϕ 473	2.268		
β 473	2.136		
500	2.173		
600	2.269		
700	2.320		

* Not shown on Plot

SPECIFIC HEAT OF TRITANIUM PENTAOXIDE Ti_3O_5

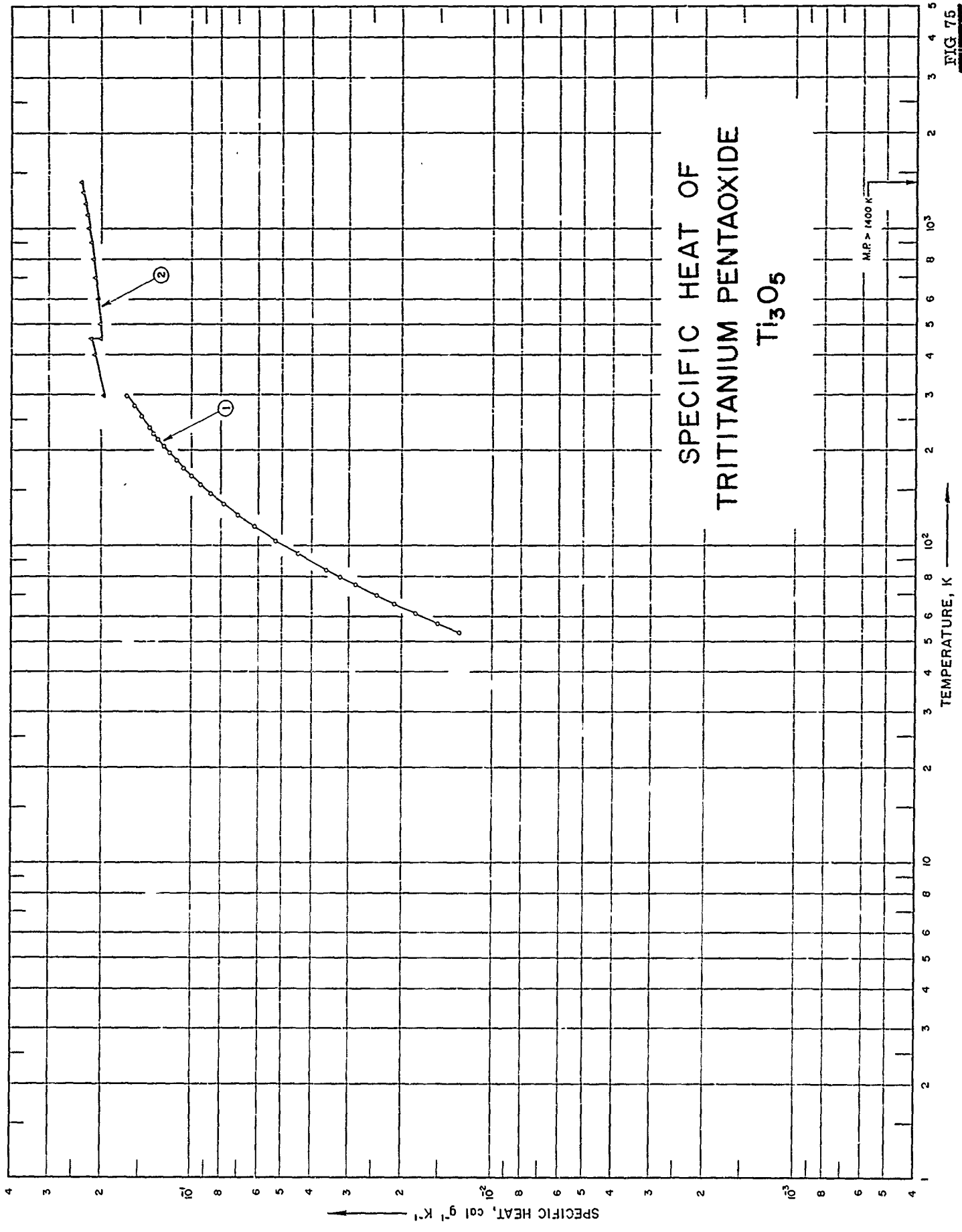

FIG 75

SPECIFICATION TABLE NO. 75 SPECIFIC HEAT OF TRITITANIUM PENTAOXIDE Ti_3O_5

[For Data Reported in Figure and Table No. 75]

Curve No.	Ref. No.	Year	Temp. Range, K	Reported Error, %	Name and Specimen Designation	Composition (weight percent), Specifications and Remarks
1	133	1946	53-298			99.1 Ti_3O_5 , 0.7 SiO_2 , and 0.2 TiC .
2	134	1946	298-1400	0.2-4		99.1 Ti_3O_5 , 0.7 SiO_2 , and 0.2 TiC ; prepared by reduction of TiO_2 with C under vacuum for 8 hrs at 1300 C.

DATA TABLE NO. 75 SPECIFIC HEAT OF TRIYTIANIUM PENTAOXIDE Ti_3O_5 [Temperature, T, K; Specific Heat, C_p , Cal g⁻¹K⁻¹]

T	C_p	
	CURVE 1	CURVE 2 (cont.)
53.1	1.286×10^{-2}	2.15×10^{-1}
56.9	1.523	2.18
61.0	1.803	2.22
65.4	2.111	2.25
69.6	2.434	2.29
75.0	2.854	2.32
79.4	3.208	2.36
83.9	3.576	
94.1	4.420	
104.3	5.284	
115.1	6.200	
125.2	7.045	
135.1	7.845	
145.8	8.672	
155.7	9.383	
165.7	1.009×10^{-1}	
175.6	1.078	
185.7	1.139	
195.9	1.198	
205.5	1.254	
216.1	1.309	
226.1	1.356	
235.8	1.399	
246.0	1.445*	
256.1	1.489	
266.2	1.529*	
276.3	1.568*	
286.3	1.603*	
296.6	1.649*	
298.16	1.654	
	CURVE 2	
α298.15	1.978×10^{-1}	
300	1.981	
400	2.113	
α450	2.179	
β450	2.02	
500	2.04	
600	2.07	
700	2.11	

* Not shown on Plot

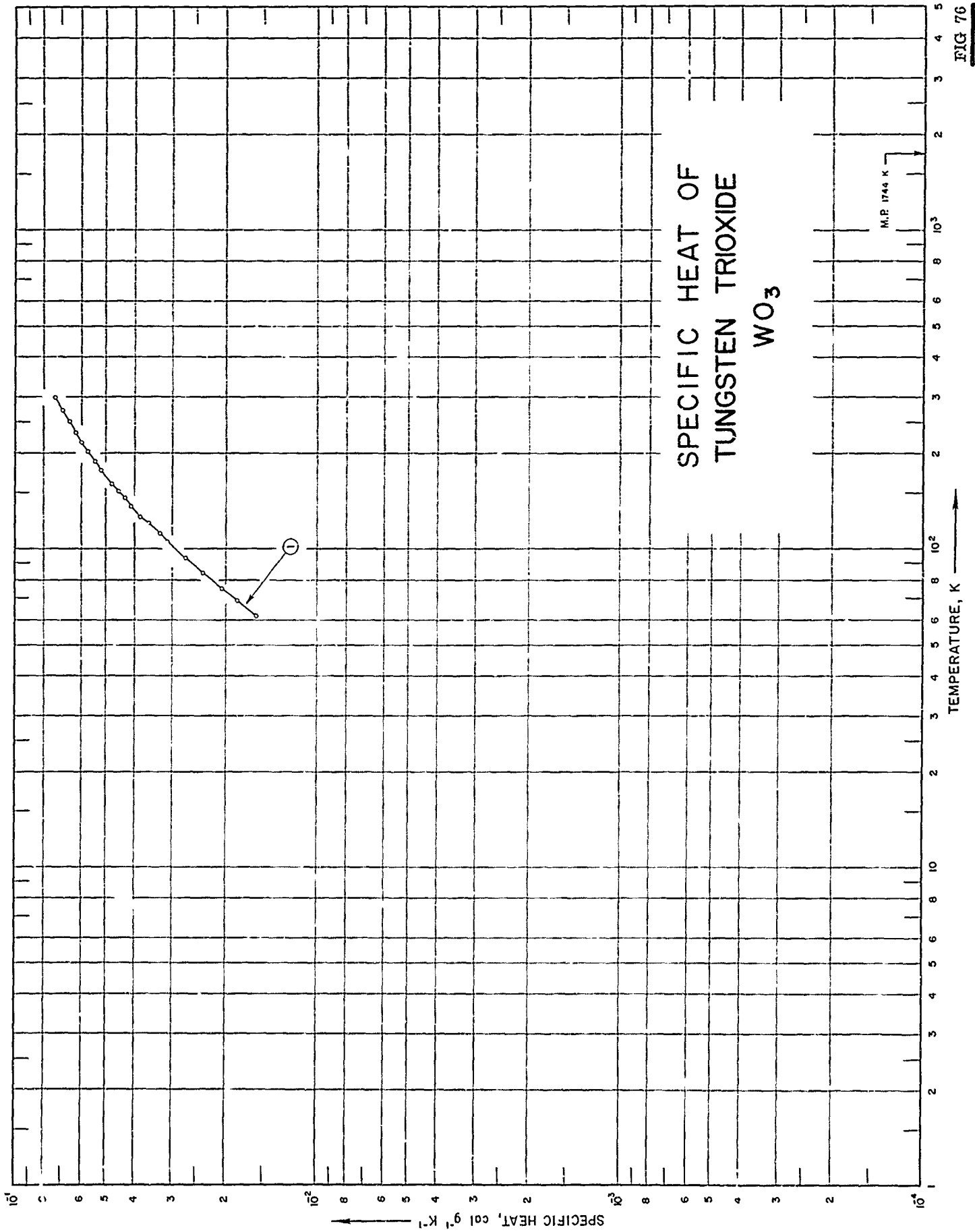

FIG 76

SPECIFICATION TABLE NO. 76 SPECIFIC HEAT OF TUNGSTEN TRIOXIDE WO_3

[For Data Reported in Figure and Table No. 76]

Curve No.	Ref. No.	Year	Temp. Range, K	Reported Error, %	Name and Specimen Designation	Composition (weight percent), Specifications and Remarks
1	106	1945	63-299	± 0.3		Rhombohedral crystal.

DATA TABLE NO. 76 SPECIFIC HEAT OF TUNGSTEN TRIOXIDE, WO₃
 [Temperature, T, K; Specific Heat, C_p, Cal g⁻¹K⁻¹]

T	C _p
CURVE I	
62.90	1.59 x 10 ⁻²
63.37	1.64*
68.98	1.84
71.55	1.97*
75.25	2.06*
79.68	2.25*
84.20	2.37
88.90	2.53*
93.80	2.72
105.22	3.14
112.44	3.31
120.52	3.63
126.86	3.854
136.30	4.126
144.96	4.327
152.88	4.566
160.16	4.801
167.68	4.979*
177.86	5.206*
183.46	5.335*
189.08	5.452
203.95	5.778*
212.20	5.963*
216.13	6.054
230.95	6.323*
236.40	6.399*
242.85	6.531*
251.79	6.626*
267.50	6.887
273.68	6.989
287.03	7.232*
299.20	7.402

* Not shown on Plot

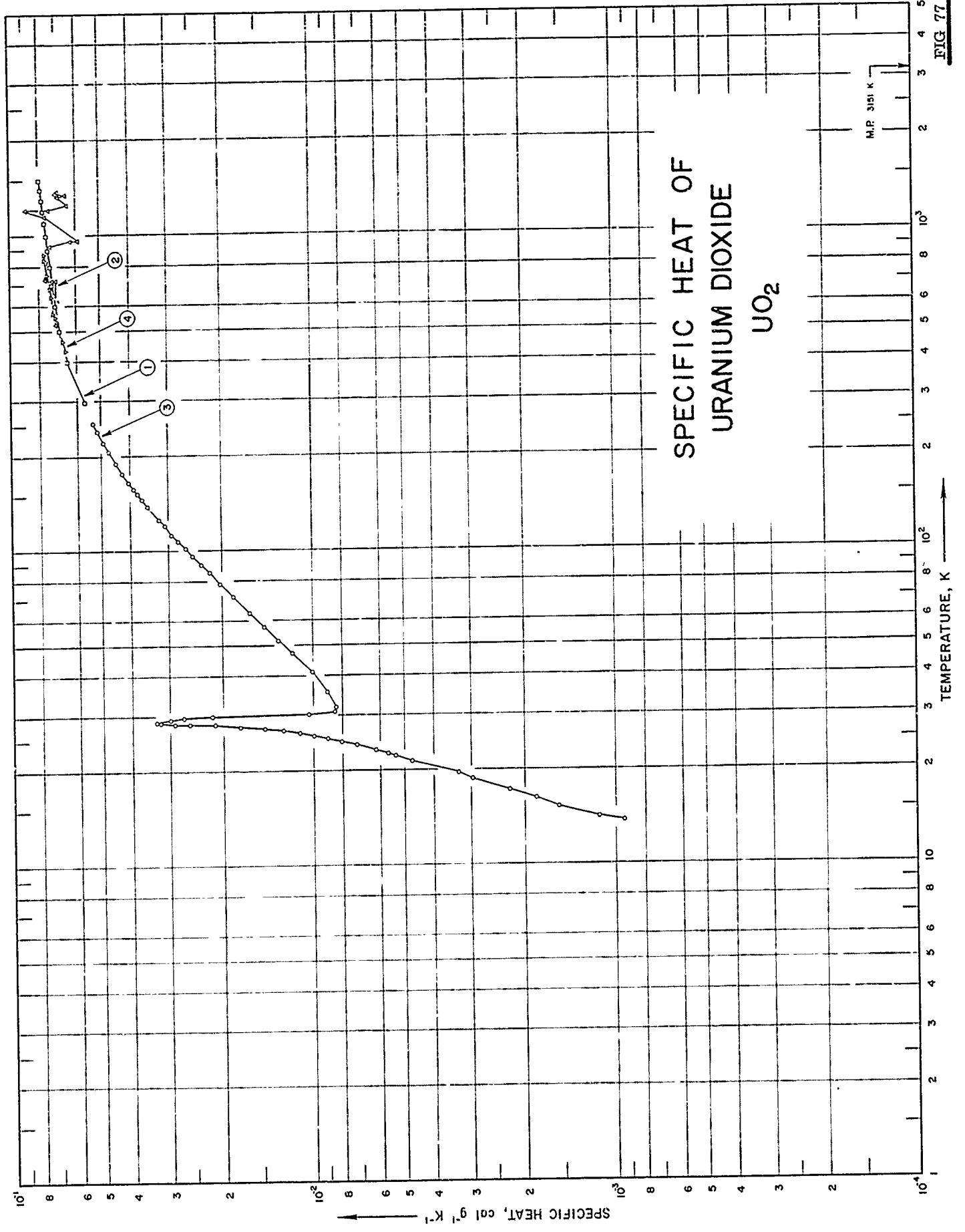

FIG. 77

SPECIFICATION TABLE NO. 77 SPECIFIC HEAT OF URANIUM DIOXIDE UO_2

[For Data Reported in Figure and Table No. 77]

Curve No.	Ref. No.	Year	Temp. Range, K	Reported Error, %	Name and Specimen Designation	Composition (weight percent), Specifications and Remarks
1	139	1947	298-1500	0.1		UO_2 , 88.26 U (theoretically 88.15).
2	140	1949	525-1378	≤ 15		99.7 UO_2 ; average values of Cp from 50 C to T C.
3	141, 142	1952	14-255	0.2		99.3 UO_2 and 0.7 UO_3 , traces of other metal oxides; 88.6 U, powder of well crystallized particles.
4	143	1958	433-876	0.8		88.0 U and < 0.01 Fe, Si; brown powder; prepared by reduction of U_3O_8 with hydrogen at 800 C.

DATA TABLE NO. 77 SPECIFIC HEAT OF URANIUM DIOXIDE UO_2
 [Temperature, T, K; Specific Heat, C_p , Cal g⁻¹ K⁻¹]

T	C_p	T	C_p	T	C_p	T	C_p
<u>CURVE 1</u>		<u>CURVE 3 (cont.)</u>		<u>CURVE 3 (cont.)</u>		<u>CURVE 4</u>	
298	5.638×10^{-2}	<u>Series 1 (cont.)</u>		<u>Series 3 (cont.)</u>		433.15	6.50×10^{-2}
300	5.661*	18.77	2.99×10^{-3}	28.16	2.572×10^{-2}	467.15	6.67
400	6.433	21.49	4.724	28.36	2.933*	494.15	6.80*
500	6.823	41.14	1.003×10^{-2}	28.54	3.226*	501.15	6.87*
600	7.082	47.20	1.169	28.71	3.325	502.15	6.87*
700	7.230	51.99	1.301	28.89	3.258*	512.15	6.96*
800	7.360	57.23	1.452	29.06	3.196*	553.15	7.04
900	7.468	<u>Series 2</u>		<u>Series 4</u>		554.15	7.02*
1009	7.563	13.68	9.40×10^{-4}	63.62	1.617×10^{-2}	571.15	7.15
1100	7.648	15.27	1.55×10^{-3}	71.60	1.837	606.15	7.18*
1200	7.727	17.29	2.25	78.96	2.024	644.15	7.24
1300	7.802	19.61	3.32	85.08	2.191	649.15	7.32*
1400	7.874	22.69	5.691	90.52	2.344	682.15	7.34
1500	7.944	28.37	2.890×10^{-2}	96.22	2.496	692.15	7.36*
<u>CURVE 2</u>		28.57	3.235	102.04	2.624	702.15	7.34*
525.15	7.0×10^{-2}	28.83	3.184*	108.09	2.774	714.15	7.45*
526.15	7.0*	29.07	3.165*	113.37	2.924	730.15	7.39*
528.15	6.9*	29.32	2.985	120.06	3.067	743.15	7.42*
722.15	7.2	29.60	2.694	126.17	3.214	757.15	7.48
728.15	7.6	29.89	2.165	139.71	3.519	766.15	7.42*
827.15	7.3	30.28	1.037	146.20	3.654	781.15	7.62*
939.15	7.5*	30.88	8.449×10^{-3}	152.45	3.777	819.15	7.60*
964.15	5.9	31.35	8.368*	158.61	3.899	830.15	7.60*
1153.15	7.6	31.94	8.402	165.21	4.025	840.15	7.64
1155.15	7.7*	32.72	8.468*	171.86	4.140*	850.15	7.68*
1161.15	7.7*	35.67	8.975	176.57	4.247	865.15	7.68*
1208.15	5.8	<u>Series 3</u>		183.81	4.354*	876.15	7.68
1212.15	7.4	22.26	5.368×10^{-3}	190.95	4.454		
1252.15	6.4	23.32	6.217	193.57	4.536*		
1336.15	6.9	24.12	7.187	200.83	4.643*		
1350.15	6.5	24.06	7.057*	207.85	4.714		
1359.15	7.0	24.78	8.013	221.36	4.928		
1378.15	6.9	25.40	8.961	228.91	4.991*		
<u>CURVE 3</u>		25.90	9.960	234.97	5.080*		
<u>Series 1</u>		26.45	1.115×10^{-2}	241.70	5.154		
14.15	1.14×10^{-3}	26.91	1.260	248.45	5.228*		
16.23	1.84	27.30	1.451	255.18	5.302		
		27.64	1.749				
		28.05	2.123				

* Not shown on plot

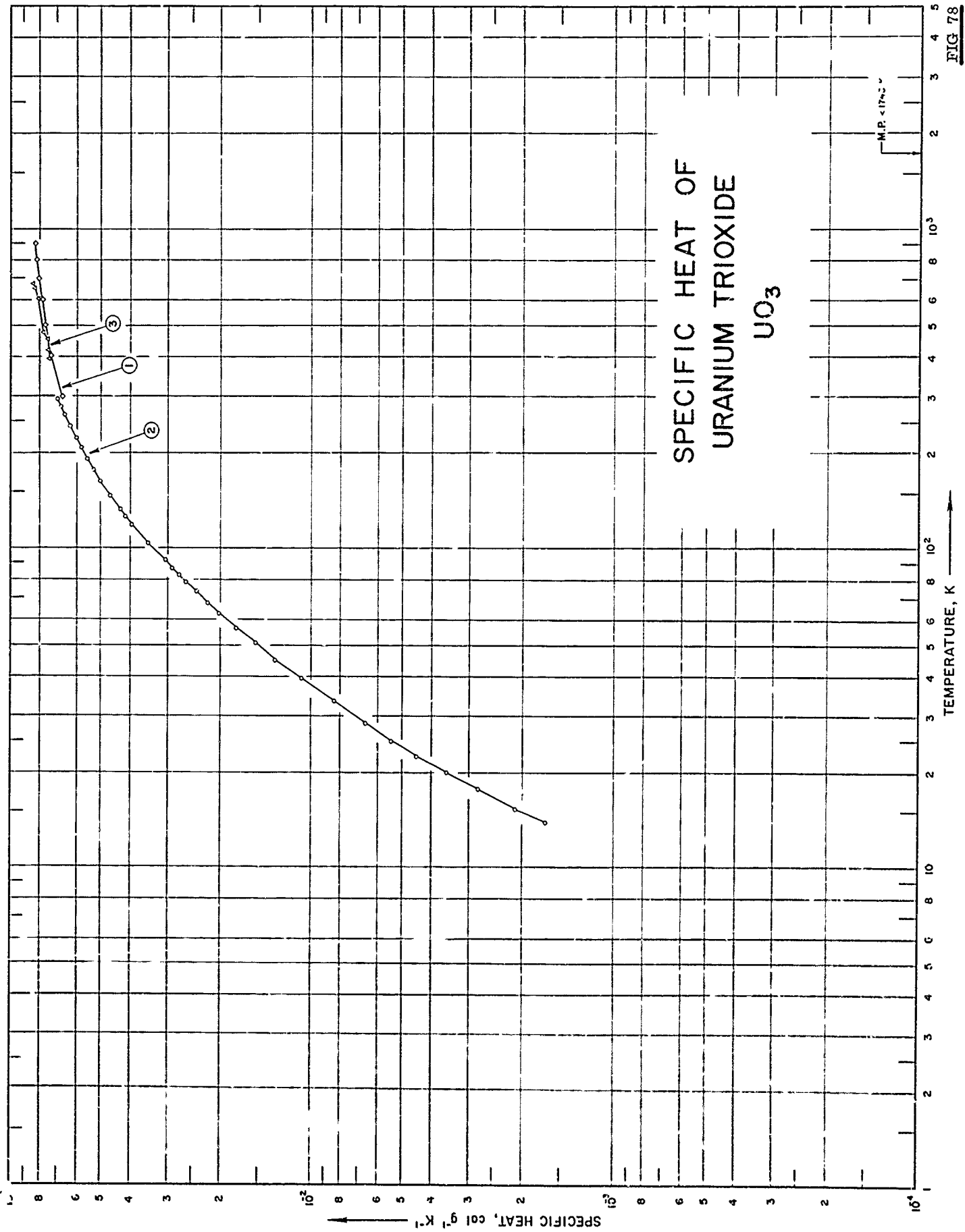

FIG 78

SPECIFICATION TABLE NO. 78 SPECIFIC HEAT OF URANIUM TRIOXIDE UO_3

[For Data Reported in Figure and Table No. 78]

Curve No.	Ref. No.	Year	Temp. Range, K	Reported Error, %	Name and Specimen Designation	Composition (weight percent), Specifications and Remarks
1	139	1947	298-500			UO_3 , 83.02 U (theoretically 83.22 U).
2	141, 142	1952	13-294	0.2 above 55K		UO_3 , 0.003 H_2O ; prepared by decomposing uranyl nitrate 8 hrs at 300 C, ground dried 3 hrs at 100 C.
3	143	1958	392-573	1.3		83.00 U and <0.003 Fe; amorphous orange powder; prepared by ignition of $UO_4 \cdot 2H_2O$ at 280 - 300 C.

DATA TABLE NO. 78 SPECIFIC HEAT OF URANIUM TRIOXIDE UO₃
 [Temperature, T, K; Specific Heat, C_p, Cal g⁻¹ K⁻¹]

T	C _p	T	C _p
<u>CURVE 1</u>			
298	6.51C x 10 ⁻²	199.74	5.761 x 10 ⁻²
300	6.834*	207.09	5.866*
400	7.428	214.29	5.995*
500	7.750	221.08	6.093
600	7.966	227.84	6.184*
700	8.131	234.84	6.292*
800	8.270	241.83	6.397
900	8.393	248.74	6.523*
<u>CURVE 2</u>			
13.81	1.69 x 10 ⁻³	256.04	6.596*
15.24	2.13	263.45	6.680
17.52	2.31	270.89	6.827*
19.96	3.580	278.46	6.882
22.32	4.506	285.84	6.890*
24.92	5.460	294.51	7.047
28.31	6.638	<u>CURVE 3</u>	
33.20	8.414	392.15	7.50 x 10 ⁻²
39.03	1.090 x 10 ⁻²	419.15	7.56
44.73	1.326	451.15	7.60
50.48	1.540	473.15	7.85*
56.59	1.793	485.15	7.87*
62.98	2.044	601.15	8.13
67.60	2.222	651.15	8.37
73.60	2.449	673.15	8.50
78.77	2.642		
82.51	2.779		
86.83	2.933		
92.09	3.083		
104.49	3.538		
119.30	3.992		
126.32	4.202		
132.86	4.366		
139.55	4.537*		
146.17	4.698		
152.71	4.848*		
156.57	4.939*		
163.16	5.983		
169.56	5.205*		
176.25	5.348*		
183.53	5.478*		
190.46	5.603		

* Not shown on plot

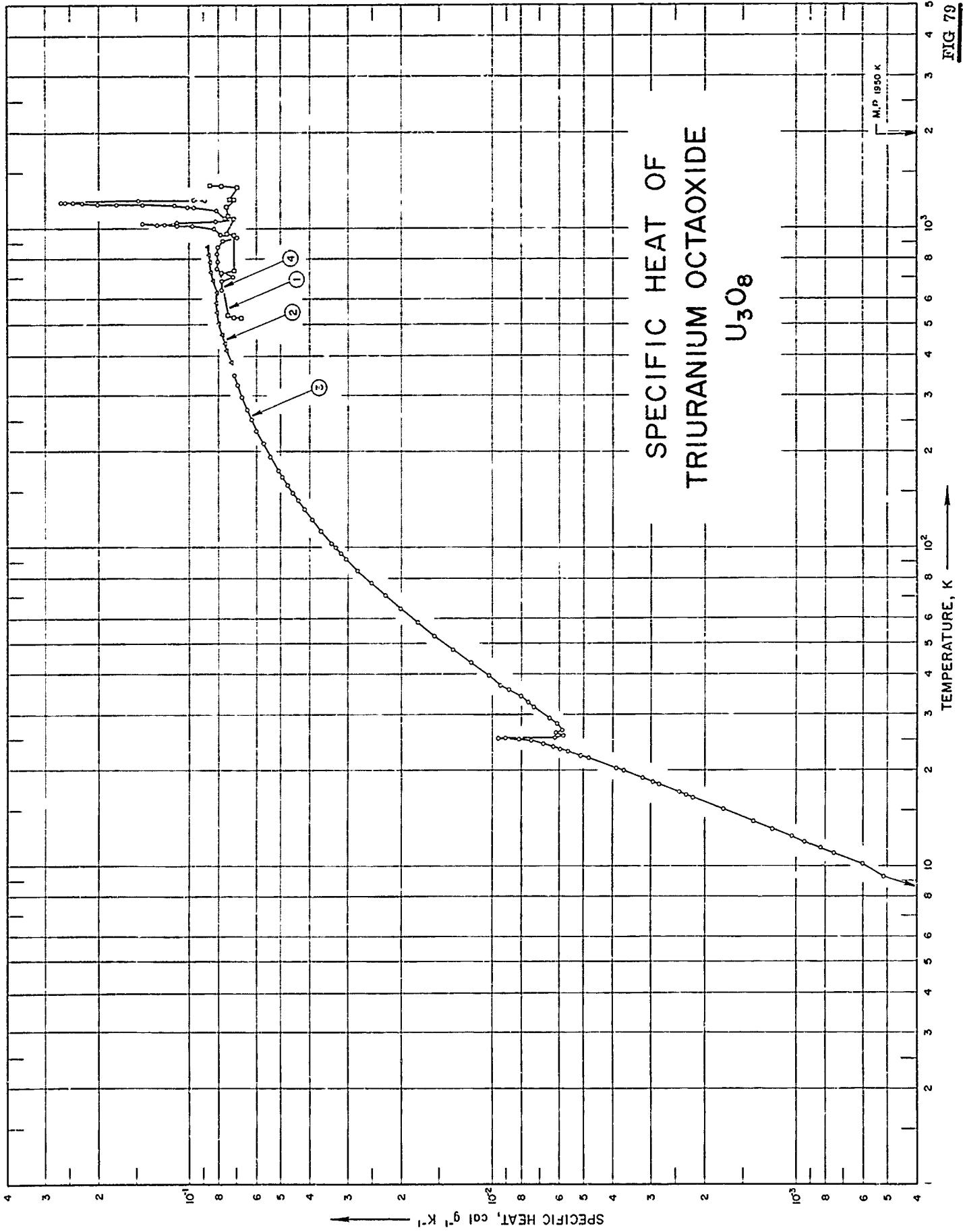

FIG 79

SPECIFICATION TABLE NO. 79 SPECIFIC HEAT OF TRIURANIUM OCTOXIDE U_3O_8

[For Data Reported in Figure and Table No. 79]

Curve No.	Ref. No.	Year	Temp. Range, K	Reported Error, %	Name and Specimen Designation	Composition (weight percent), Specifications and Remarks
1	144	1949	526-1365	≤15		Nearly 100 U_3O_8 ; average values of Cp from 50 C to 7C.
2	143	1953	380-875	0.6		84.79 U, 0.002 Fe, Si; deep olive green powder; prepared by ignition of $UO_2(NO_3)_2 \cdot 6H_2O$ at 850 C.
3	145	1959	5-347	0.1-1		0.020 Si, 0.006 Al, 0.003 Mg, 0.002 Ni, 0.001 Fe, 0.0003 Cu, and 0.000008 > B; prepared from uranyl nitrate hexahydrate, the U_3O_8 produced was reduced to UO_2 by heating in dry purified hydrogen gas at 500 C until H_2O formation ceased, temperature raised to 1200 C and sample kept at this temperature for 4 hrs before cooling to room temperature, oxidized in air at 800 C to constant weight and then heated 7 days at 800 C under vacuum, cooled to room temperature over 2 months.
4	146	1961	641-1233	1-3		84.78 U.

DATA TABLE NO. 79 SPECIFIC HEAT OF THURANIUM OCTOXIDE U₃O₈

[Temperature, T, K; Specific Heat, C_p, Cal g⁻¹ K⁻¹]

CURVE 1		CURVE 2 (cont.)		CURVE 3		CURVE 3 (cont.)		CURVE 3 (cont.)		CURVE 3 (cont.)		CURVE 3 (cont.)		CURVE 4		CURVE 5 (cont.)		CURVE 6		CURVE 6 (cont.)			
T	C _p	T	C _p	T	C _p	T	C _p	T	C _p	T	C _p	T	C _p	T	C _p	T	C _p	T	C _p	T	C _p	T	C _p
526.15	6.8 x 10 ⁻²	590.15	8.237 x 10 ⁻² *	95.80	3.180 x 10 ⁻²	36.93	9.451	13.59	1.337 x 10 ⁻³ *	17.11	2.445 x 10 ⁻³	18.94	3.214	26.15	5.779 x 10 ⁻³ *	641.15	7.85 x 10 ⁻²	22.17	5.015*	662.15	7.86*	26.34	5.747*
528.15	7.2	600.15	8.169*	103.64	3.426	39.63	1.031 x 10 ⁻²	14.96	1.735*	18.94	3.214	22.32	5.800*	26.48	5.919*	662.15	7.86*	23.22	5.800*	662.15	7.86*	26.48	5.919*
725.15	7.9	607.15	8.186*	112.78	3.696			16.47	2.205	22.32	5.800*	23.22	5.800*	26.68	5.794*	662.15	7.86*	24.17	6.680*	662.15	7.86*	26.68	5.794*
726.15	8.0*	615.15	8.250*	122.11	3.953			18.09	2.844	24.17	6.680*	24.17	6.680*	27.97	6.160*	662.15	7.86*	24.73	7.388*	662.15	7.86*	27.97	6.160*
739.15	8.0*	623.15	8.260*	131.23	4.189			19.96	3.708	24.17	6.680*	24.73	7.388*			662.15	7.86*	25.11	8.252*	662.15	7.86*		
951.15	7.2	624.15	8.143*	140.23	4.403			21.92	4.849	25.11	8.252*	25.11	8.252*			662.15	7.86*	25.41	9.113	662.15	7.86*		
961.15	7.6	631.15	8.174	148.76	4.593			23.07	5.664	25.41	9.113	25.41	9.113			662.15	7.86*	25.49	9.173*	662.15	7.86*		
1086.15	7.2	635.15	8.219*	157.14	4.768			23.46	6.330	25.49	9.173*	25.49	9.173*			662.15	7.86*	25.58	10.11	662.15	7.86*		
1095.15	7.5*	637.15	8.247*	165.91	4.936			23.83	6.995*	25.58	10.11	25.58	10.11			662.15	7.86*	25.65	11.45	662.15	7.86*		
1097.15	7.5*	648.15	8.307*	175.01	5.109			24.18	7.695*	25.65	10.11	25.65	10.11			662.15	7.86*	25.73	12.57	662.15	7.86*		
1174.15	7.6	652.15	8.313*	184.09	5.272*			24.83	8.331	25.73	12.57	25.73	12.57			662.15	7.86*	26.00	13.94	662.15	7.86*		
1242.15	7.4	653.15	8.237*	193.22	5.424			25.13	8.938*	26.00	13.94	26.00	13.94			662.15	7.86*	26.12	15.41	662.15	7.86*		
1242.15	7.4	661.15	8.345*	202.34	5.570*			25.42	9.586*	26.12	15.41	26.12	15.41			662.15	7.86*	26.12	16.94	662.15	7.86*		
1247.15	7.5*	667.15	8.300*	211.63	5.714			25.72	10.338*	26.12	15.41	26.12	15.41			662.15	7.86*	26.12	18.51	662.15	7.86*		
1350.15	7.0	676.15	8.402*	221.06	5.852*			26.00	11.194*	26.12	15.41	26.12	15.41			662.15	7.86*	26.12	20.17	662.15	7.86*		
1357.15	7.9	688.15	8.388					26.50	12.146*	26.12	15.41	26.12	15.41			662.15	7.86*	26.12	21.84	662.15	7.86*		
1364.15	8.5*	707.15	8.440*					26.50	13.194*	26.12	15.41	26.12	15.41			662.15	7.86*	26.12	23.57	662.15	7.86*		
1365.15	8.6	715.15	8.458*					26.50	14.342*	26.12	15.41	26.12	15.41			662.15	7.86*	26.12	25.34	662.15	7.86*		
		718.15	8.464*					26.50	15.590*	26.12	15.41	26.12	15.41			662.15	7.86*	26.12	27.22	662.15	7.86*		
		729.15	8.484*					26.50	16.938*	26.12	15.41	26.12	15.41			662.15	7.86*	26.12	29.17	662.15	7.86*		
		730.15	8.503					26.50	18.386*	26.12	15.41	26.12	15.41			662.15	7.86*	26.12	31.35	662.15	7.86*		
		741.15	8.529*					26.50	20.034*	26.12	15.41	26.12	15.41			662.15	7.86*	26.12	33.66	662.15	7.86*		
		753.15	8.541*					26.50	21.882*	26.12	15.41	26.12	15.41			662.15	7.86*	26.12	36.19	662.15	7.86*		
		755.15	8.554*					26.50	23.930*	26.12	15.41	26.12	15.41			662.15	7.86*	26.12	38.84	662.15	7.86*		
		422.15	7.576*					26.50	26.178*	26.12	15.41	26.12	15.41			662.15	7.86*	26.12	41.68	662.15	7.86*		
		437.15	7.666					26.50	28.726*	26.12	15.41	26.12	15.41			662.15	7.86*	26.12	44.71	662.15	7.86*		
		459.15	7.775*					26.50	31.474*	26.12	15.41	26.12	15.41			662.15	7.86*	26.12	47.94	662.15	7.86*		
		463.15	7.828*					26.50	34.422*	26.12	15.41	26.12	15.41			662.15	7.86*	26.12	51.47	662.15	7.86*		
		464.15	7.831					26.50	37.570*	26.12	15.41	26.12	15.41			662.15	7.86*	26.12	55.34	662.15	7.86*		
		485.15	7.945*					26.50	40.918*	26.12	15.41	26.12	15.41			662.15	7.86*	26.12	59.45	662.15	7.86*		
		504.15	8.030					26.50	44.466*	26.12	15.41	26.12	15.41			662.15	7.86*	26.12	63.81	662.15	7.86*		
		508.15	8.03					26.50	48.214*	26.12	15.41	26.12	15.41			662.15	7.86*	26.12	68.44	662.15	7.86*		
		513.15	8.009*					26.50	52.162*	26.12	15.41	26.12	15.41			662.15	7.86*	26.12	73.35	662.15	7.86*		
		526.15	8.095*					26.50	56.310*	26.12	15.41	26.12	15.41			662.15	7.86*	26.12	78.46	662.15	7.86*		
		528.15	8.080*					26.50	60.658*	26.12	15.41	26.12	15.41			662.15	7.86*	26.12	83.91	662.15	7.86*		
		530.15	8.047*					26.50	65.306*	26.12	15.41	26.12	15.41			662.15	7.86*	26.12	89.51	662.15	7.86*		
		530.15	8.047*					26.50	70.254*	26.12	15.41	26.12	15.41			662.15	7.86*	26.12	95.36	662.15	7.86*		
		543.15	8.131					26.50	75.502*	26.12	15.41	26.12	15.41			662.15	7.86*	26.12	101.35	662.15	7.86*		
		555.15	8.143*					26.50	81.150*	26.12	15.41	26.12	15.41			662.15	7.86*	26.12	107.59	662.15	7.86*		
		558.15	8.169*					26.50	87.198*	26.12	15.41	26.12	15.41			662.15	7.86*	26.12	114.09	662.15	7.86*		
		572.15	8.181*					26.50	93.646*	26.12	15.41	26.12	15.41			662.15	7.86*	26.12	120.84	662.15	7.86*		
		573.15	8.186*					26.50	100.494*	26.12	15.41	26.12	15.41			662.15	7.86*	26.12	127.94	662.15	7.86*		
		575.15	8.206*					26.50	107.742*	26.12	15.41	26.12	15.41			662.15	7.86*	26.12	135.39	662.15	7.86*		
		586.15	8.206					26.50	115.490*	26.12	15.41	26.12	15.41			662.15	7.86*	26.12	143.13	662.15	7.86*		

* Not shown on plot

DATA TABLE NO. 79 (continued)

T	C _p
<u>CURVE 4 (cont.)</u>	
1189.15	1.432 x 10 ⁻¹
1193.55	1.750
1197.95	2.012
1202.35	2.269
1206.75	2.447
1211.15	2.585
1215.15	2.663
1220.15	2.457*
1224.55	1.481
1228.95	8.90 x 10 ⁻²
1233.35	9.70

* Not shown on plot

FIG 80

SPECIFIC HEAT OF
TETRAURANIUM NONAOXIDE
U4O9

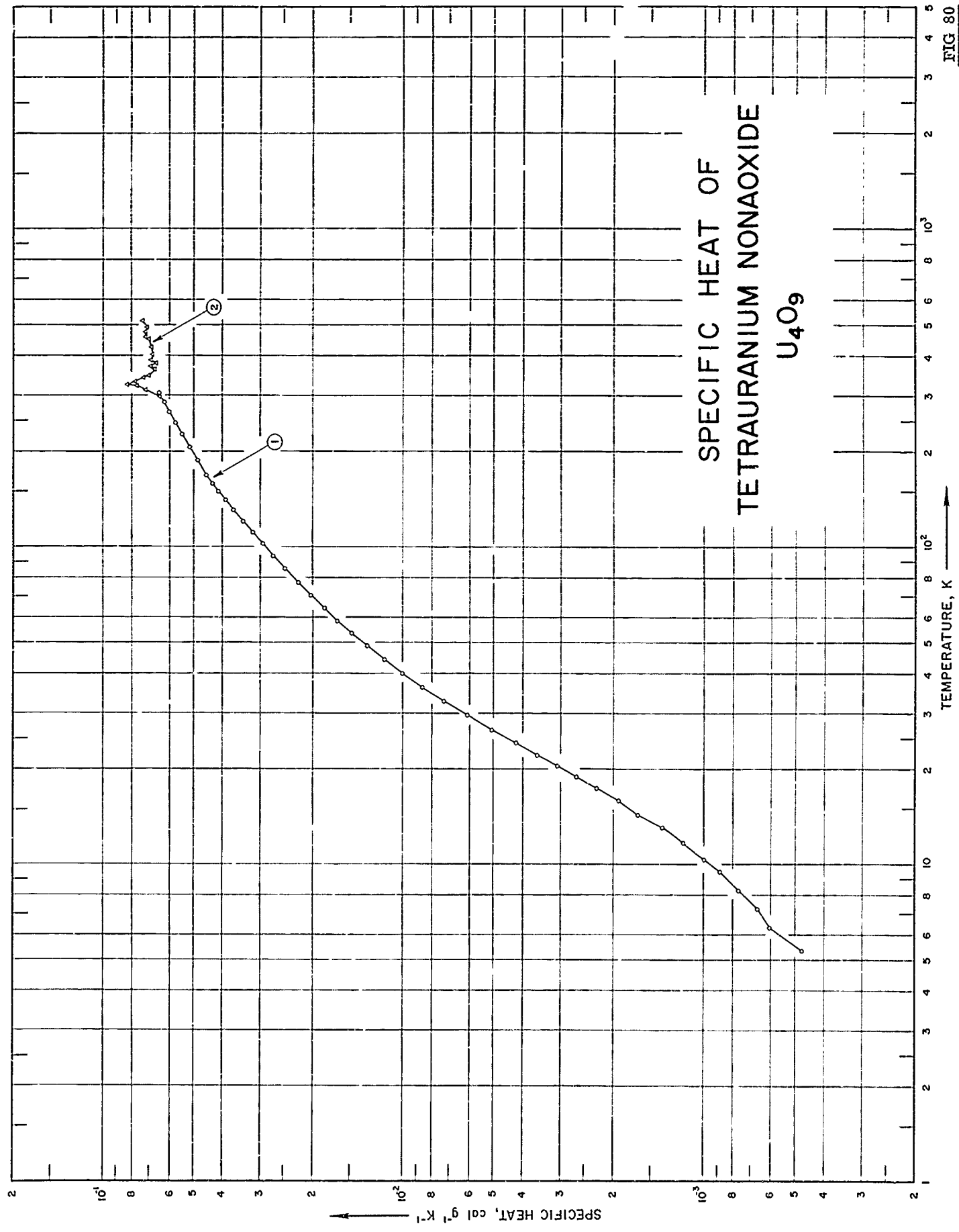

SPECIFICATION TABLE NO. 80 SPECIFIC HEAT OF TETRAURANIUM NONAOXIDE U_4O_9

[For Data Reported in Figure and Table No. 80]

Curve No.	Ref. No.	Year	Temp. Range, K	Reported Error, %	Name and Specimen Designation	Composition (weight percent), Specifications and Remarks
1	147	1957	5-310	0.1 above 5K 1 at 14 K and 5 at 5 K		<p>U_4O_9, 86.81 ± 0.08 U (86.86 theoretical), 13.14 ± 0.02 O_2 (13.14 theoretical), 0.007 Si, 0.001 Al, 0.001 Cu, 0.0007 Fe, 0.0005 Mg, 0.0001 Pb, and 0.00002 B; preparation: U_2O_8 reduced to UO_2 by heating in alumina boats in a stream of anhydrous hydrogen at 500 C until evolution of H_2O ceased, then heating for additional 4 hrs at 1200 C, cooled in H_2 atmosphere, stoichiometric UO_2 and U_3O_8 were mixed in quartz tubes and evaluated; mixture heated 7 days at 800 C and gradually cooled to 20 C over 2 months period.</p> <p>Prepared from 99.9 powdered UO_2; UO_2 was reduced in dry hydrogen gas 12-20 hrs, part of UO_2 was oxidized in air at 650 C for 5 hrs to U_3O_8. Stoichiometric mixture of UO_2 and U_3O_8 were ground and mixed carefully to homogeneous, heated at 950 C for 180 hrs and then gradually cooled down to room temperature for 100 hrs.</p>
2	148	1965	297-515			

DATA TABLE NO. 80 SPECIFIC HEAT OF TETRAURANIUM NONAOXIDE U_3O_8
 [Temperature, T, K; Specific Heat, C_p , Cal $g^{-1} K^{-1}$]

T	C_p	T	C_p	T	C_p
CURVE 1		CURVE 1 (cont.)		CURVE 2 (cont.)	
Series 1					
5.37	4.743×10^{-4}	130.54	3.663×10^{-2}	333	7.82×10^{-2}
6.32	6.020	140.24	3.894	337	7.64*
7.23	6.659	150.01	4.113	347	7.04
8.28	7.662	159.70	4.320	355	6.86*
9.46	8.848	169.27	4.515	363	6.72
10.42	9.943	169.14	4.511*	371	6.96
11.71	1.168×10^{-3}	178.59	4.692*	379	6.68
13.05	1.377	178.59	4.864	387	6.91
14.44	1.654	187.33	5.019*	395	6.89*
15.91	1.926	206.79	5.177	403	6.85
17.46	2.270	216.47	5.321*	411	6.91*
18.98	2.654	226.29	5.467	419	6.86*
20.49	3.083	236.22	5.604*	427	6.91
22.18	3.582	246.27	5.747	435	6.82*
24.13	4.220	256.46	5.877*	443	7.00*
26.62	5.070	266.75	6.015	451	7.05
29.57	6.111	276.88	6.143*	459	7.22
32.76	7.259	286.92	6.265	467	7.08*
36.29	8.617	296.88	6.381*	475	7.23
40.00	1.003×10^{-2}	306.82	6.518	483	7.08*
44.28	1.154	Series 3			
48.90	1.318	9.28	8.483×10^{-4} *	491	7.15
53.72	1.484	10.65	1.003×10^{-3} *	499	7.05*
58.72	1.651	11.98	1.795*	507	7.00*
64.17	1.830	13.26	1.423*	515	7.40
70.46	2.024	14.56	1.669*		
77.61	2.240	15.99	1.945*		
85.46	2.477	17.53	2.285*		
93.72	2.708	CURVE 2			
102.64	2.947	297	6.49×10^{-2}		
Series 2					
63.05	1.793×10^{-2} *	301	6.44*		
69.39	1.992*	305	7.09*		
76.58	2.209*	309	7.04*		
84.39	2.444*	313	7.22		
92.59	2.675*	317	7.47*		
101.49	2.916*	321	7.72		
111.14	3.173	325	8.31		
120.91	3.423	329	8.36		

*Not shown on plot

SPECIFIC HEAT OF
VANADIUM MONOXIDE
VO

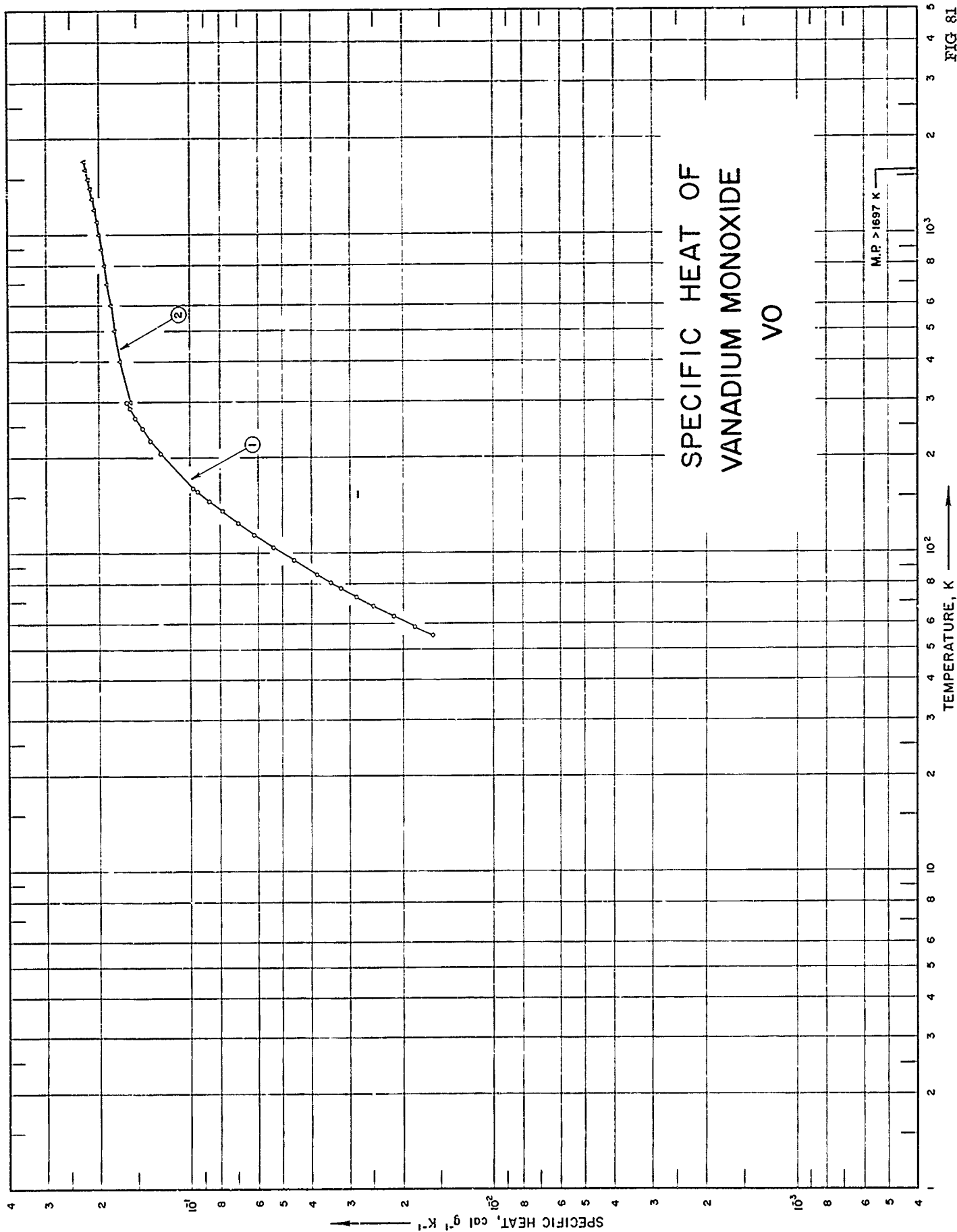

FIG 81

SPECIFICATION TABLE NO. 81 SPECIFIC HEAT OF VANADIUM MONOXIDE VO

[For Data Reported in Figure and Table No. 81]

Curve No.	Ref. No.	Year	Temp. Range, K	Reported Error, %	Name and Specimen Designation	Composition (weight percent), Specifications and Remarks
1	77	1951	54-298			98.2 VO; 74.72 V, 0.92 Si, 0.23 NaO, and 0.10 Fe.
2	102	1954	298-1700			98.2 VO, small amounts of V ₂ O ₃ .

DATA TABLE NO. 81 SPECIFIC HEAT OF VANADIUM MONOXIDE VO
 [Temperature, T, K; Specific Heat, C_p , Cal $g^{-1} K^{-1}$]

T	C_p	
	CURVE 1	CURVE 2 (cont.)
54.97	1.585×10^{-2}	2.214×10^{-1}
58.61	1.818	1700
63.11	2.134	2.248
68.07	2.496	
72.87	2.844	
77.61	3.198	
80.49	3.432	
85.40	3.806	
94.98	4.563	
104.53	5.323	
114.72	6.157	
124.62	6.951	
135.96	7.860	
146.22	8.680	
155.95	9.419	
160.46	9.788	
206.39	1.251×10^{-1}	
216.23	1.303*	
226.13	1.352*	
237.24	1.403*	
245.79	1.439	
256.10	1.479*	
266.20	1.519	
275.58	1.552*	
286.34	1.589	
296.36	1.619*	
298.16	1.622	
CURVE 2		
298.15	1.578×10^{-1}	
300	1.581*	
400	1.706	
500	1.781	
600	1.837	
700	1.885	
800	1.927	
900	1.965	
1000	2.004	
1100	2.040	
1200	2.076	
1300	2.111	
1400	2.145	
1500	2.180	

* Not shown on plot

SPECIFIC HEAT OF VANADIUM SESQUIOXIDE V_2O_3

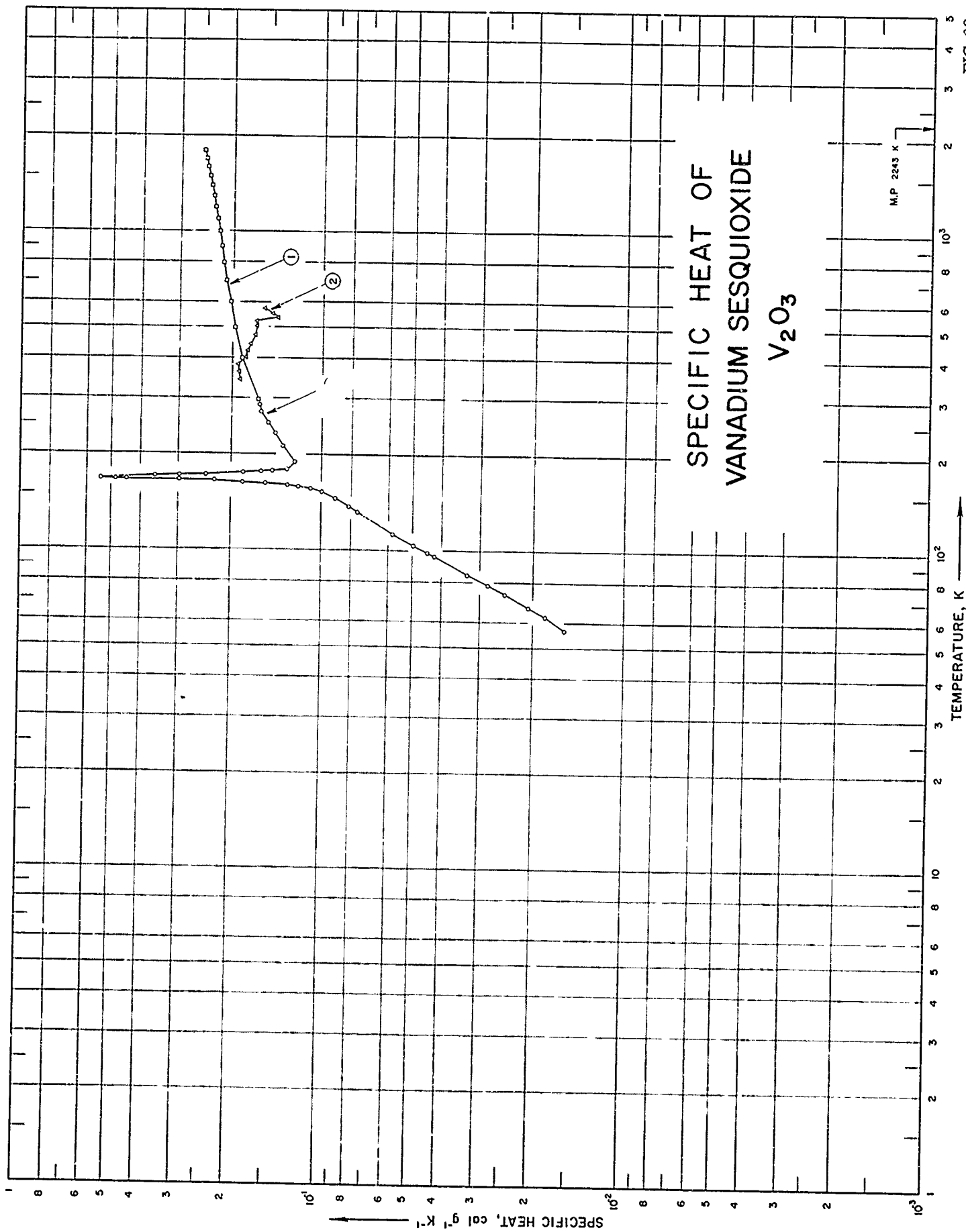

SPECIFICATION TABLE NO. 82 SPECIFIC HEAT OF VANADIUM SESQUIOXIDE V_2O_5

[For Data Reported in Figure and Table No. 82]

Curve No.	Ref. No.	Year	Temp. Range, K	Reported Error, %	Name and Specimen Designation	Composition (weight percent), Specifications and Remarks
1	149	1947	298-1500			67.89 V; prepared by heating pure V_2O_5 in a silica flask at 800 C in a stream of pure hydrogen until no further water vapor has evolved.
2	150	1951	343-573	2.0		
3	151	1936	57-287			Powder compressed into pellets at pressure of 2 tons per in. ² ; density 4.83 g cm ⁻³ at 22.0 C.

DATA TABLE NO. 82 SPECIFIC HEAT OF VANADIUM SESQUIOXIDE V_2O_5 [Temperature, T, K; Specific Heat, C_p , Cal g $^{-1}$ K $^{-1}$]

T	C_p	T	C_p	T	C_p	
CURVE 1		CURVE 3		CURVE 3 (cont.)		
298.15	1.646×10^{-1}	Series 1				Series 2 (cont.)
300	1.651*	56.9	1.571×10^{-2}	153.8	1.020×10^{-1} *	
400	1.859	62.5	1.829	161.6	1.394*	
500	1.972	66.9	2.077	168.4	4.500*	
600	2.106	73.4	2.488	169.4	5.094*	
700	2.155	78.4	2.825	178.8	1.406*	
800	2.199	84.6	3.308	187.9	1.238*	
900	2.239	96.2	4.225	192.3	1.250*	
1000	2.277	113.5	5.803	157.6	1.129*	
1100	2.313	132.4	7.618	186.3	1.241*	
1200	2.349	145.7	9.033	153.1	1.004*	
1300	2.384	213.8	1.357×10^{-1}	193.9	1.257*	
1400	2.418	234.7	1.448	152.9	1.002*	
1500	2.451	231.3	1.524	157.4	1.115*	
1600	2.485	273.0	1.604			
1700	2.485	287.2	1.628			
1800	2.518	98.9	4.461×10^{-2}			
		104.4	4.374			
		137.7	8.139			
		Series 2				
343.15	1.89×10^{-1}	165.7	2.276×10^{-1}			
353.15	1.89*	189.9	1.241			
363.15	1.90	153.2	1.008			
373.15	1.91*	156.9	1.037			
383.15	1.92*	159.2	1.202			
393.15	1.89*	161.0	1.303			
403.15	1.83	164.7	1.547			
413.15	1.81*	166.6	2.371			
423.15	1.79	167.7	4.448			
433.15	1.76*	168.4	4.856			
443.15	1.75	169.2	5.406			
453.15	1.73*	170.9	3.562			
463.15	1.71*	171.9	2.976			
473.15	1.69	173.0	2.437			
483.15	1.68*	175.2	1.835			
493.15	1.67*	176.7	1.598			
503.15	1.67	178.2	1.460			
513.15	1.67*	180.4	1.313*			
523.15	1.67	182.0	1.288*			
538.15	1.43	185.2	1.242*			
543.15	1.45*					
553.15	1.48					
563.15	1.52*					
573.15	1.55					

* Not shown on plot

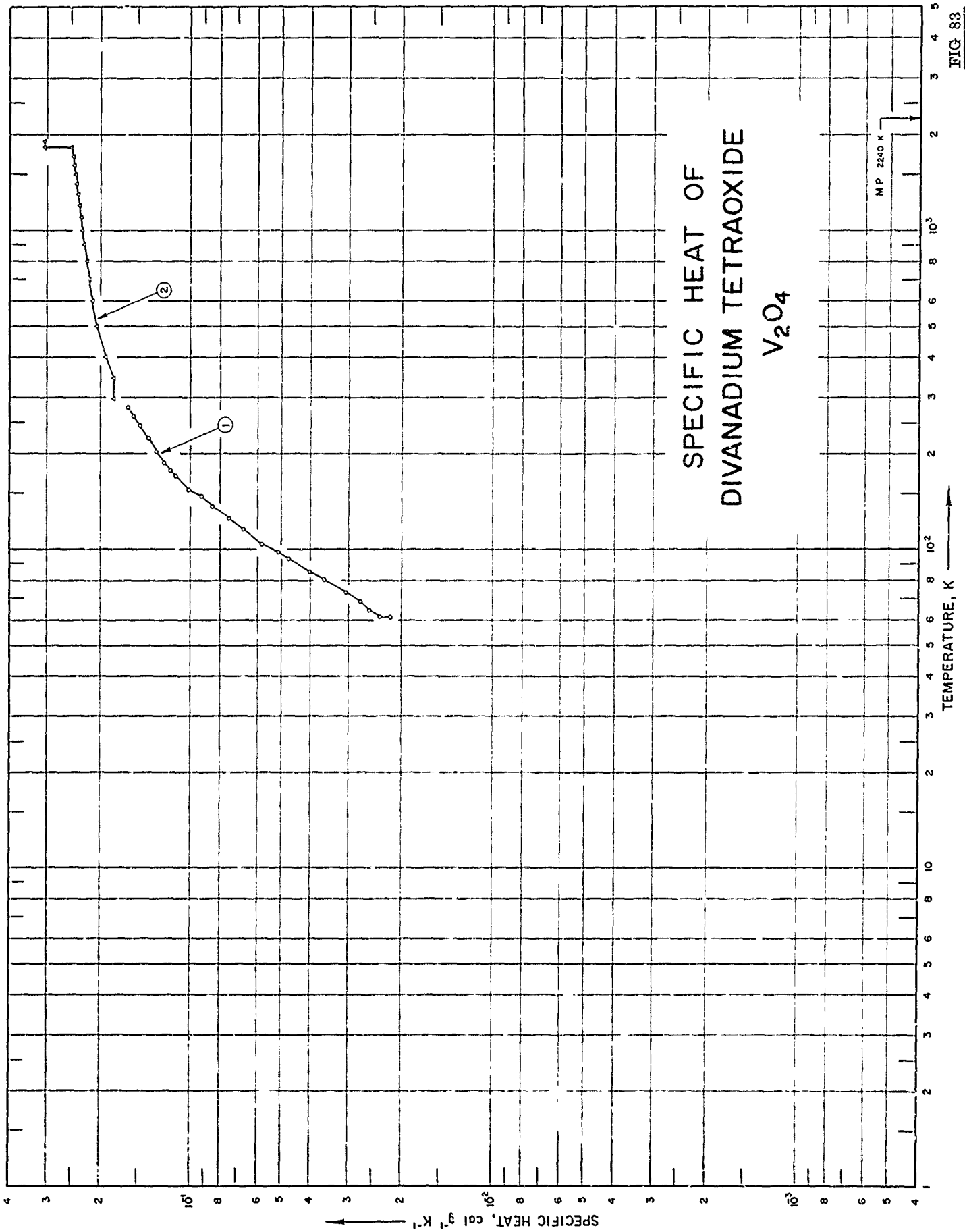

FIG 83

SPECIFICATION TABLE NO. 83 SPECIFIC HEAT OF DIVANADIUM TETRAOXIDE V_2O_4

[For Data Reported in Figure and Table No. 83]

Curve No.	Ref. No.	Year	Temp. Range, K	Reported Error, %	Name and Specimen Designation	Composition (weight percent), Specifications and Remarks
1	151	1936	61-279			Powder compressed into pellets at 2 tons per in. ² pressure; density 4.260 at 21.4 C. 61.45 V; prepared from pure vanadium trioxide by controlled oxidation with air in a platinum vessel at 300 C; placed in silica flask, evacuated at room temperature and given prolonged heat treatment below 600 C.
2	149	1947	298-1900			

DATA TABLE NO. 83 SPECIFIC HEAT OF DIVANADIUM TETRAOXIDE V_2O_4 [Temperature, T, K; Specific Heat, C_p , Cal $g^{-1} K^{-1}$]

T	CURVE 1		CURVE 2	
	T	C_p	T	C_p
Series 1				
61.4	2.188	10^{-2}	298.15	1.803×10^{-1}
68.8	2.751		300	1.803
73.5	3.061		(α) 345	1.803*
80.5	3.612		(β) 345	1.823*
84.9	4.020		400	1.936
89.6	4.474		500	2.064
93.6	4.744		600	2.142
98.1	5.136		700	2.198
104.7	5.816		800	2.241
115.7	6.703		900	2.277
125.6	7.492		1000	2.309
137.4	8.505		1100	2.338
147.0	9.228		1200	2.364
154.7	1.014	10^{-1}	1300	2.390
170.1	1.222		1400	2.414
176.9	1.177		1500	2.438
188.0	1.234		1600	2.461
203.7	1.310		1700	2.483
212.3	1.347*		1800	2.506*
224.2	1.394		(β) 1818	2.510
234.0	1.436*		(1) 1818	3.074
245.8	1.493		1900	3.074
262.6	1.555			
270.9	1.591*			
279.4	1.625			
Series 2				
61.4	2.363	10^{-2}		
64.9	2.587			
100.3	5.375*			
144.7	9.138*			
157.1	1.056*			
187.6	1.228*			
165.2	1.136*			
137.3	1.045*			
162.2	1.091*			

Not shown on plot

SPECIFIC HEAT OF
DIVANADIUM PENTAOXIDE
 V_2O_5

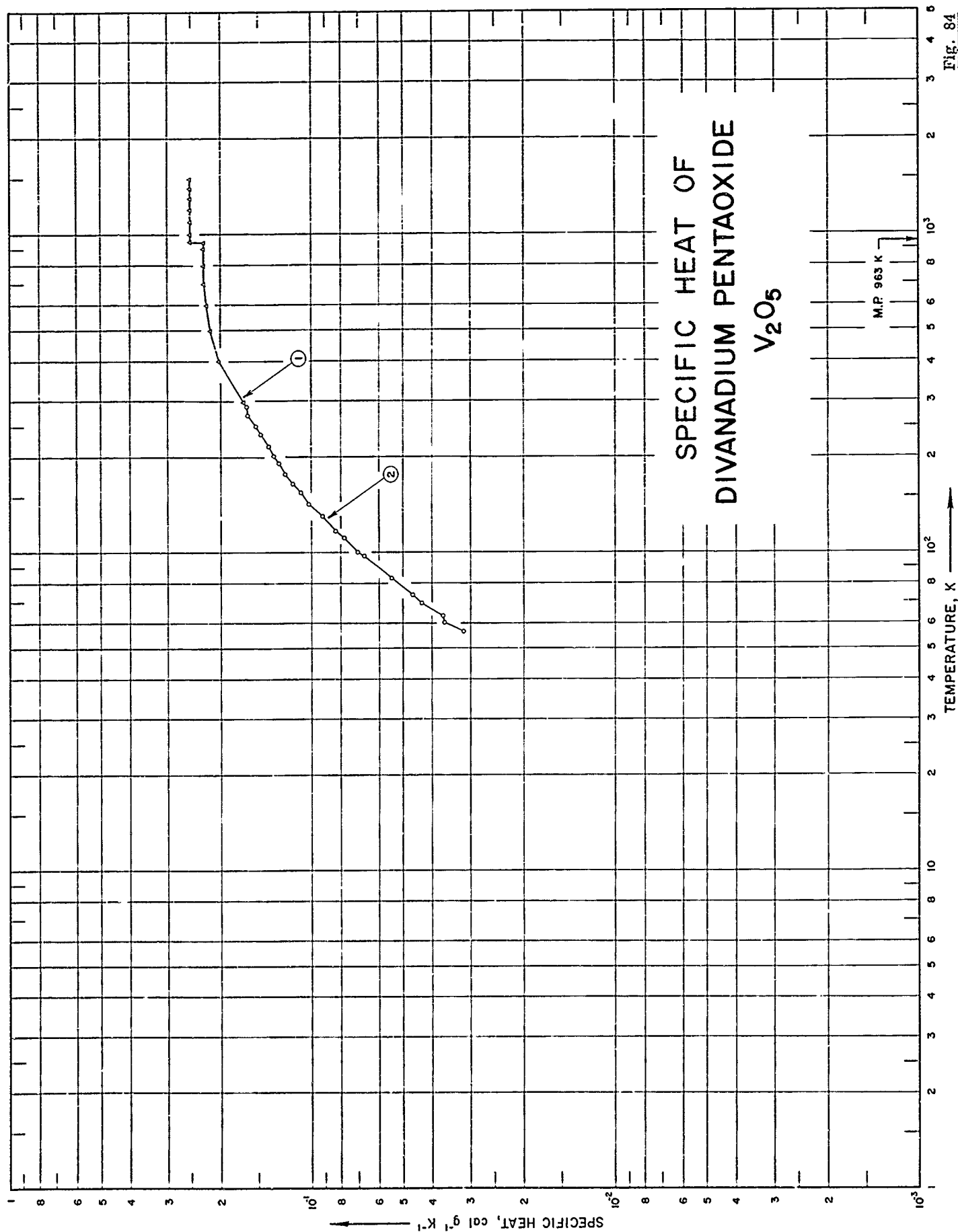

Fig. 84

SPECIFICATION TABLE NO. 84 SPECIFIC HEAT OF DIVANADIUM PENTAOXIDE V_2O_5

[For Data Reported in Figure and Table No. 84]

Curve No.	Ref. No.	Year	Temp. Range, K	Reported Error, %	Name and Specimen Designation	Composition (weight percent), Specifications and Remarks
1	149	1947	298-1500			55.96 V; prepared from purified ammonium vanadate by heating in platinum vessel in a stream of pure hydrogen at 440-460 C for 7 days.
2	151	1936	57-290			Powder compressed into pellets at pressure of 2 tons per in. ² .

DATA TABLE NO. 84 SPECIFIC HEAT OF DIVANADIUM PENTAOXIDE V_2O_5
 [Temperature, T, K; Specific Heat, C_p , Cal $g^{-1} K^{-1}$]

T	C_p
<u>CURVE 1</u>	
298.15	1.677×10^{-1}
300	1.686*
400	2.018
500	2.160
600	2.228
700	2.260
800	2.273
900	2.276
(s) 943	2.275
(1) 943	2.507
1000	2.507
1100	2.507
1200	2.507
1300	2.507
1400	2.507
1500	2.507
<u>CURVE 2</u>	
56.8	3.174×10^{-2}
60.4	3.659
63.7	3.689
69.6	4.352
73.9	4.675
83.4	5.454
98.0	6.701
100.9	7.053
111.9	7.801
117.7	8.340
130.4	9.203
143.9	1.020×10^{-1}
155.3	1.089
165.2	1.151
178.0	1.222
191.4	1.286
202.6	1.343
217.8	1.390
223.8	1.434*
235.7	1.476
251.0	1.548
271.3	1.631
279.9	1.647*
289.5	1.644

* Not shown on plot

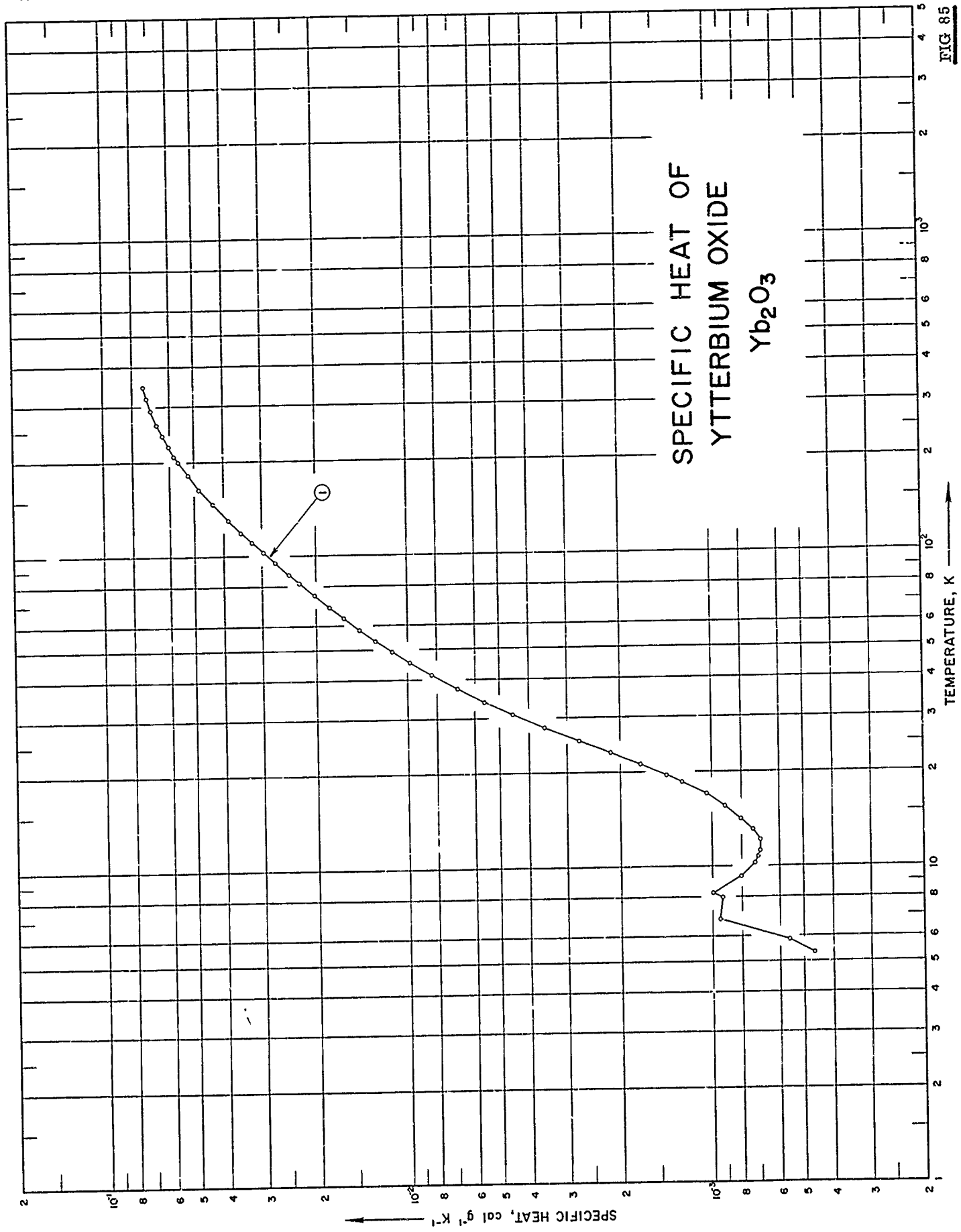

FIG. 85

SPECIFICATION TABLE NO. 85 SPECIFIC HEAT OF YTTERBIUM OXIDE Yb_2O_3

[For Data Reported in Figure and Table No. 85]

Curve No.	Ref. No.	Year	Temp. Range, K	Reported Error, %	Name and Specimen Designation	Composition (weight percent), Specifications and Remarks
1	72	1962	5-346	0.1		99.9 Yb_2O_3 , 0.050 Lu, 0.010 Ca, and 0.010 Si; powder specimen; supplied by Michigan Chemical Company; measured in helium atmosphere.

DATA TABLE NO. 85 SPECIFIC HEAT OF YTTERBIUM OXIDE Yb_2O_3
 [Temperature, T, K; Specific Heat, C_p , Cal g⁻¹ K⁻¹]

T	C_p	T	C_p
CURVE 1		CURVE 1 (cont.)	
Series 1			
87.12	2.455×10^{-2}	57.98	1.446×10^{-2}
95.08	2.715	63.08	1.627
103.01	2.975	68.45	1.811
111.08	3.242	74.68	2.020
119.46	3.516	81.67	2.263
Series 2			
5.32	4.643×10^{-4}	123.56	3.643×10^{-2} *
5.85	5.608	130.85	3.874
6.80	9.439	138.66	4.113*
7.97	9.287	147.00	4.360
9.27	8.036	155.54	4.598*
10.76	7.054	164.30	4.829
Series 3			
8.21	9.973×10^{-4}	173.23	5.052*
9.22	8.095*	182.45	5.271
10.29	7.232	191.73	5.479*
11.29	6.952	200.86	5.663
12.15	6.952	209.88	5.836
13.07	7.358	Series 6	
14.17	8.019	214.95	5.933×10^{-2} *
15.55	9.034	224.22	6.088
17.03	1.048×10^{-3}	233.32	6.237*
18.53	1.254	242.54	6.379
Series 4			
19.55	1.411×10^{-3}	251.72	6.494*
21.18	1.726	255.06	6.544*
23.05	2.154	263.89	6.648
25.27	2.746	272.94	6.752*
27.94	3.553	281.98	6.846*
30.88	4.532	291.15	6.930
33.89	5.598	300.41	7.016*
37.32	6.867	309.84	7.093*
41.28	8.323	319.34	7.161
45.37	9.874	328.76	7.224*
49.26	1.132×10^{-2}	338.09	7.280*
53.34	1.279	346.72	7.336

* Not shown on plot

FIG 86

SPECIFIC HEAT OF YTTRIUM OXIDE Y_2O_3

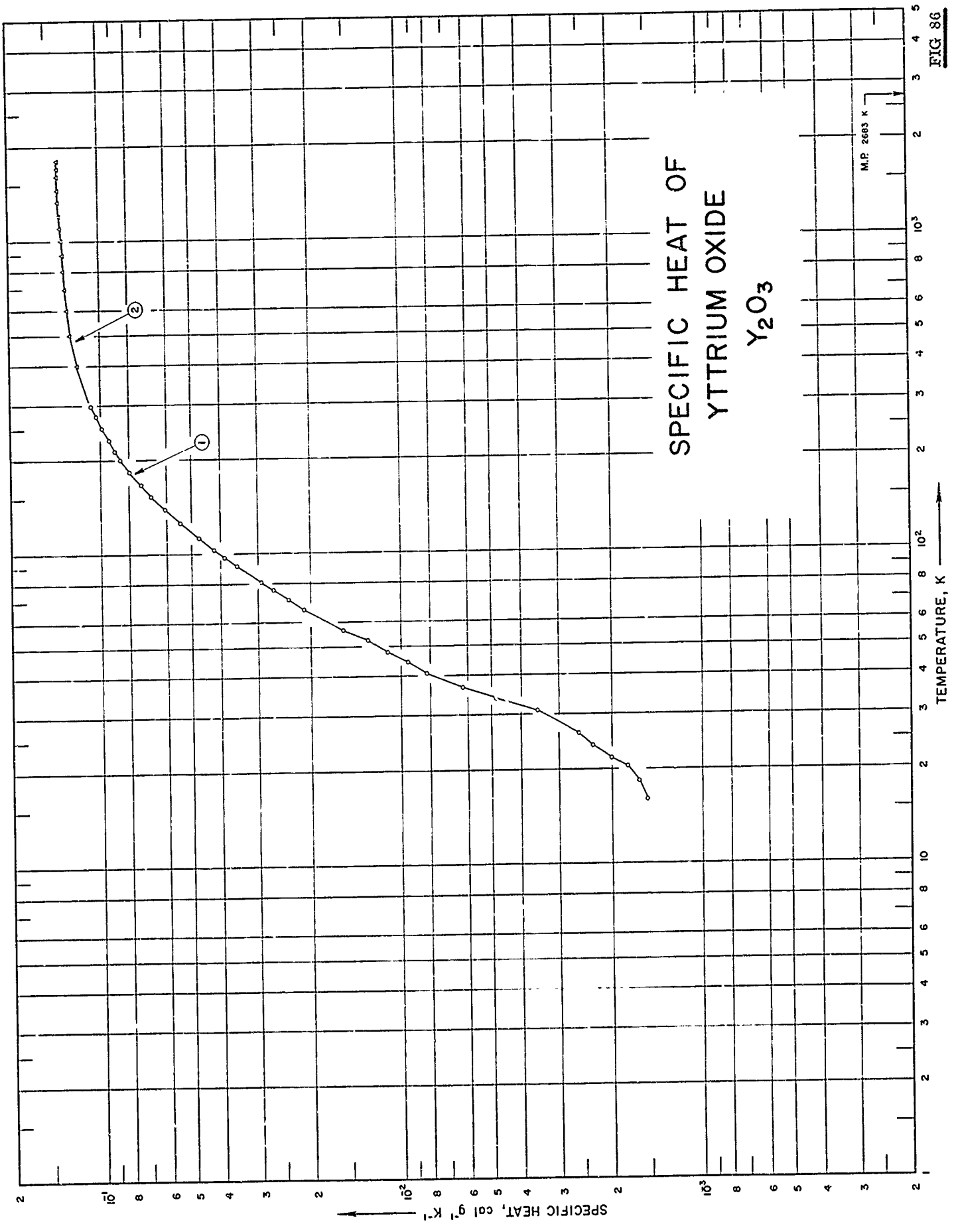

SPECIFICATION TABLE NO. 86 SPECIFIC HEAT OF YTTRIUM OXIDE Y_2O_3

[For Data Reported in Figure and Table No. 86]

Curve No.	Ref. No.	Year	Temp. Range, K	Reported Error, %	Name and Specimen Designation	Composition (weight percent), Specifications and Remarks
1	83	1959	16-298			>99.9 Y_2O_3 , < 0.01 Gd_2O_3 , < 0.01 Dy_2O_3 , and < 0.02 Ho_2O_3 , supplied by Lindsay Chemical Company; heated to constant weight at 950 C for 24 hours in air to decompose hydroxides or carbonates.
2	73	1962	298-1799	0.2		99.99 Y_2O_3 ; measured in helium atmosphere.

DATA TABLE NO. 86 SPECIFIC HEAT OF YTTRIUM OXIDE Y_2O_3 [Temperature, T, K; Specific Heat, C_p , Cal $g^{-1}K^{-1}$]

T	C_p	T	C_p
15.96	1.528×10^{-3}	214.27	8.990×10^{-2}
18.37	1.625	219.22	9.136*
20.45	1.776	225.62	9.269*
21.63	2.006	232.05	9.428*
23.87	2.334	238.41	9.597*
26.01	2.582	240.33	9.654*
30.85	3.547	246.77	9.787*
33.86	4.863	253.61	9.955
36.67	6.275	263.59	1.021×10^{-1} *
40.93	8.215	266.48	1.020*
44.34	9.499	276.56	1.044
47.86	1.112×10^{-2}	279.94	1.055*
52.15	1.298	283.31	1.057*
56.33	1.566	292.36	1.081*
65.78	2.105	298.26	1.084
70.75	2.387		
76.13	2.662		
80.83	2.946		
81.81	3.003*		
91.08	3.549*		
93.81	3.676*		
97.02	3.896		
100.06	4.065*		
102.83	4.228*		
106.21	4.390*		
108.42	4.530*		
112.44	4.756		
118.75	5.124*		
125.23	5.450		
131.89	5.766*		
138.96	6.134		
146.21	6.483*		
153.27	6.816		
160.92	7.143*		
166.50	7.369		
173.02	7.653*		
176.95	7.759		
184.37	8.064		
186.58	8.153*		
193.37	8.374*		
200.19	8.645		
207.07	8.844*		
212.86	8.977		

CURVE 2	
(α) 298	1.0883×10^{-1} *
300	1.0916*
400	1.1998
500	1.2527
600	1.2839
700	1.3048
800	1.3203
900	1.3325
1000	1.3428
1100	1.3518
1200	1.3599
1300	1.3674*
(α) 1330	1.3695
(β) 1330	1.3728*
1400	1.3728
1500	1.3728
1600	1.3728
1700	1.3728
(β) 1799	1.3728

* Not shown on plot

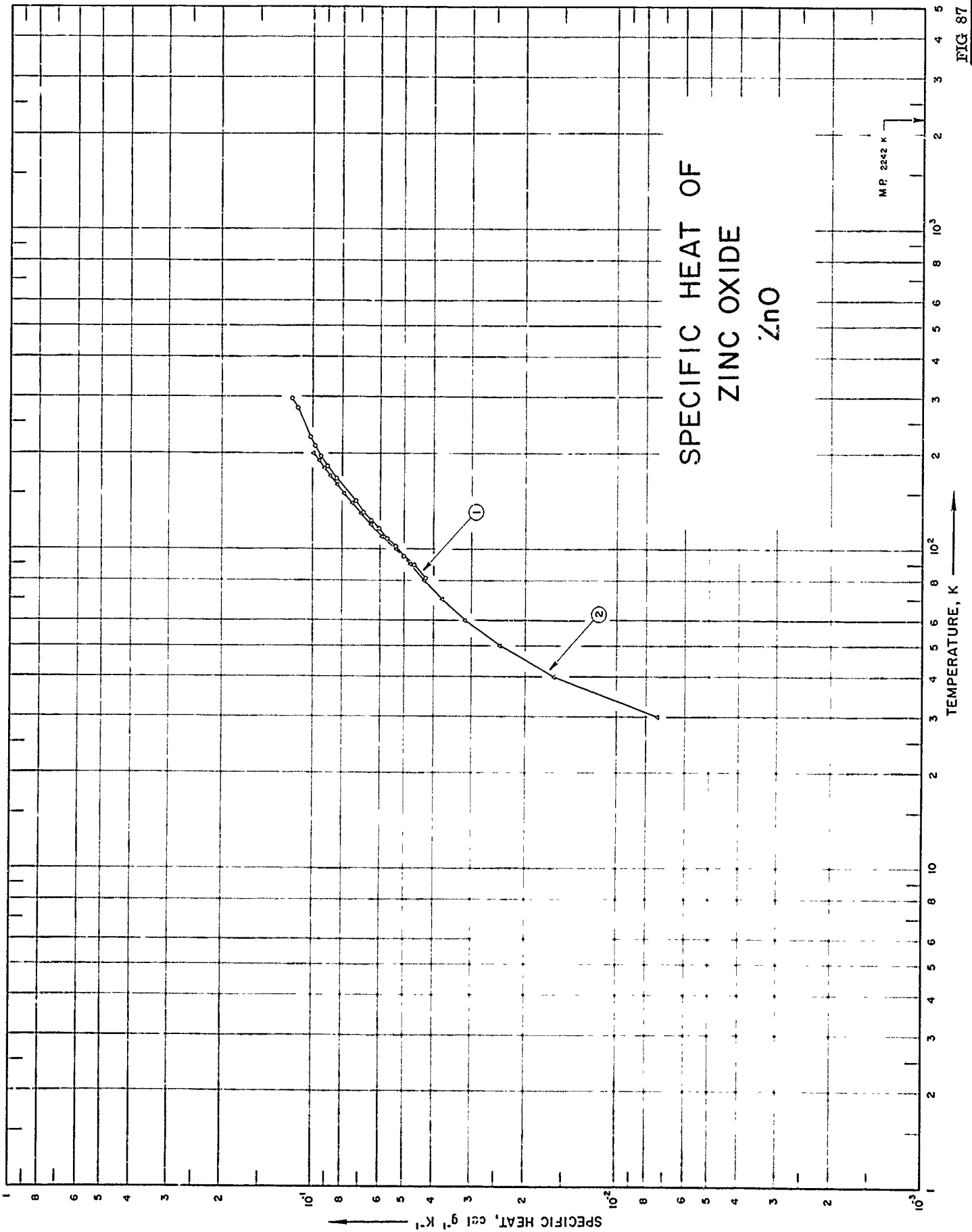

FIG 87

SPECIFICATION TABLE NO. 87 SPECIFIC HEAT OF ZINC OXIDE ZnO

[For Data Reported in Figure and Table No. 87]

Curve No.	Ref. No.	Year	Temp. Range, K	Reported Error, %	Name and Specimen Designation	Composition (weight percent), Specifications and Remarks
1	152	1928	81-298			99.9 ZnO; microcrystalline.
2	68	1928	30-200			

DATA TABLE NO. 87 SPECIFIC HEAT OF ZINC OXIDE ZnO
 [Temperature, T, K; Specific Heat, C_p , Cal g⁻¹ K⁻¹]

T	C_p		T	C_p
	CURVE 1	CURVE 2 (cont.)		
81.8	4.286 x 10 ⁻²	5.92 x 10 ⁻²	110	6.46
84.2	4.376*	6.46	120	6.96
89.7	4.662	7.45	130	7.45
95.8	5.014	7.91	140	7.91
102.5	5.376	8.36	150	8.36
109.0	5.713	8.77	160	8.77
116.6	6.072	9.19	170	9.19
120.1	6.240*	9.56	180	9.56
124.2	6.435	9.95	190	9.95
128.7	6.697*		200	
131.2	6.852			
134.9	6.943*			
139.2	7.122*			
142.9	7.244			
167.0	8.378			
174.7	8.674*			
183.2	8.981			
189.7	9.275*			
196.8	9.458			
204.7	9.825*			
210.8	9.894			
220.1	1.0101 x 10 ⁻¹ *			
225.0	1.0221			
228.4	1.0375*			
231.8	1.0338*			
277.3	1.1387			
282.5	1.1551*			
284.8	1.1590*			
286.9	1.1707*			
289.1	1.1649*			
295.3	1.1380*			
297.9	1.1847			

CURVE 2	
30	7.4 x 10 ⁻³
40	1.62 x 10 ⁻²
50	2.43
60	3.15
70	3.76
80	4.30
90	4.79
100	5.33

* Not shown on plot

FIG. 88

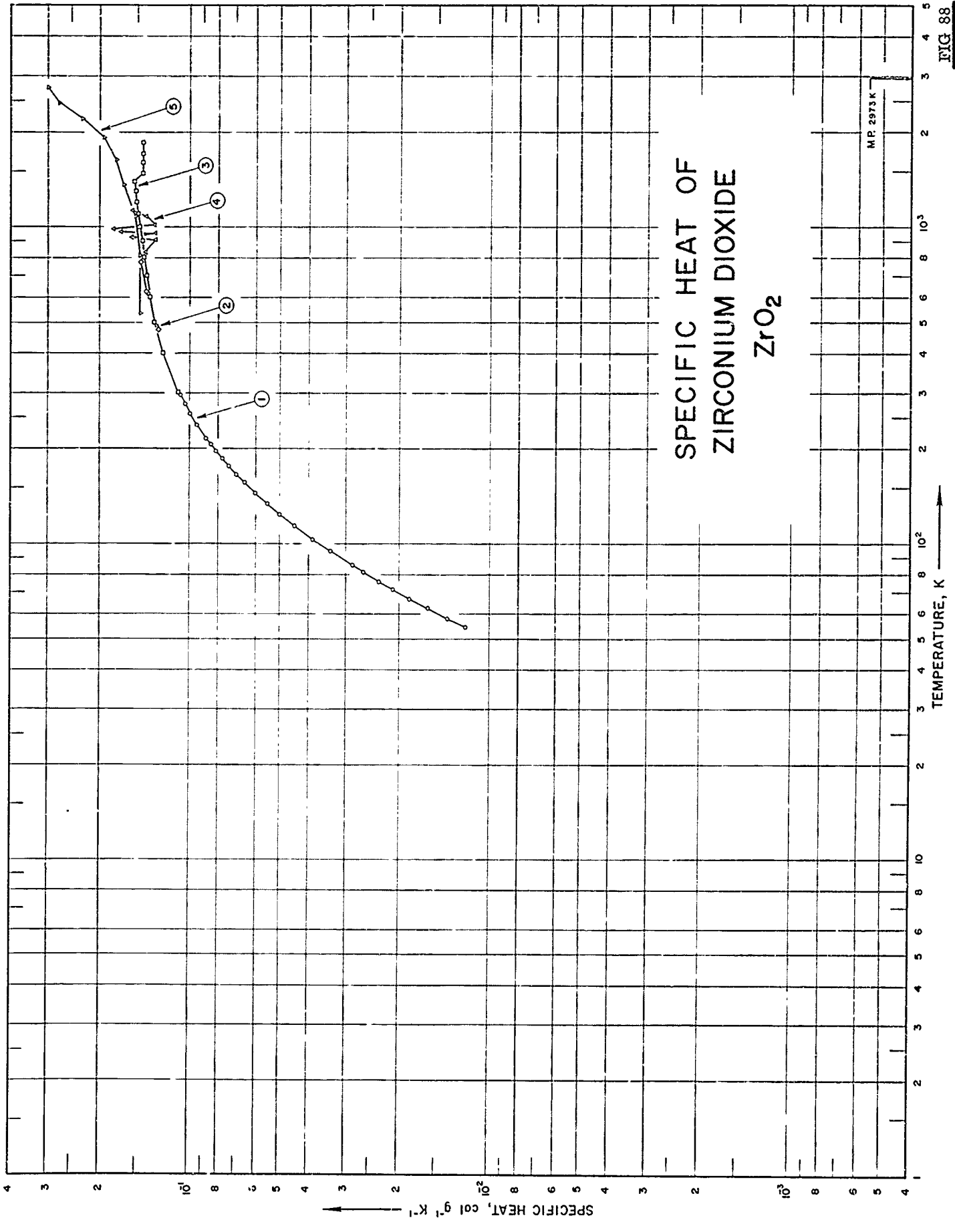

U.S. GOVERNMENT PRINTING OFFICE: 1964 O 548-000

SPECIFICATION TABLE NO. 88 SPECIFIC HEAT OF ZIRCONIUM DIOXIDE ZrO_2

[For Data Reported in Figure and Table No. 88]

Curve No.	Ref. No.	Year	Temp. Range, K	Reported Error, %	Name and Specimen Designation	Composition (weight percent), Specifications and Remarks
1	153	1944	54-295	0.3		99.14 ZrO_2 , 0.30 SiO_2 , 0.20 TiO_2 , 0.07 CaO , and ≤ 0.05 other oxides; corrected for impurities.
2	92	1950	473-773			ZrO_2 and 1.25 Hf; x-ray diffraction showed only monoclinic oxide.
3	154	1950	298-1850	0.2		Sample A, B, and C one inch diameter; density 271 lb ft ⁻³ , sample D, density 342 lb ft ⁻³ . Before exposure: 70.7 Zr, 1.0 Ca, 0.1 Al, 0.1 Mg, 0.1 Si, and 0.1 Ti, after exposure:
4	155	1961	836-1127			71.2 Zr, and 0.15 C; sample supplied by Zirconium Corp. of America; crushed in hardened steel mortar to pass 100-mesh screen; pressed and sintered; density at 25 C, apparent density (ASTM method B311-58) 334 lb ft ⁻³ , true density (by immersion in xylene) 351 lb ft ⁻³ , after exposure: apparent density 334 lb ft ⁻³ , true density 357 lb ft ⁻³ .
5	48	1962	533-2755	≤ 5		

DATA TABLE NO. 88 SPECIFIC HEAT OF ZIRCONIUM DIOXIDE ZrO_2 [Temperature, T, K; Specific Heat, Cp, Cal g⁻¹ K⁻¹]

T	Cp	T	Cp	T	Cp
<u>CURVE 1</u>					
54.3	1.195×10^{-2}	(α) 700	1.397×10^{-1}	533.15	1.47×10^{-1}
57.9	1.373	800	1.425	810.93	1.47
62.2	1.589	900	1.448	1088.71	1.52
66.8	1.834	1000	1.469	1366.48	1.67
71.4	2.088	1100	1.489	1644.26	1.77
75.7	2.319	1200	1.507	1922.04	1.95
81.0	2.606	1300	1.524	2199.82	2.30
85.3	2.844	1400	1.541	2477.59	2.75
94.6	3.369	(α) 1478	1.445	2755.37	3.00
103.6	3.871	(β) 1478	1.445		
114.0	4.440	1500	1.445*		
124.3	4.994	1600	1.445		
134.3	5.487	1700	1.445		
144.9	6.005	1800	1.445*		
155.4	6.505	1850	1.445		
165.0	6.932	<u>CURVE 4</u>			
175.3	7.350	Series 1			
185.1	7.740	836.16	1.41×10^{-1}		
195.4	8.139	867.16			
205.1	8.472	Series 2			
215.0	8.814*	924.16	1.57×10^{-1}		
225.2	9.106*	963.16	1.70		
235.7	9.406	986.16	1.80		
245.5	9.681*	Series 3			
255.6	9.933	907.16	1.31×10^{-1}		
265.9	1.019×10^{-1} *	907.16	1.33*		
276.1	1.042	907.16	1.33*		
285.8	1.061*	953.16	1.30		
295.0	1.077	1016.66	1.31		
		1085.16	1.40		
		1127.16	1.56		
<u>CURVE 2</u>					
473	1.27×10^{-1}				
623	1.40				
773	1.46				
<u>CURVE 3</u>					
(α) 298	1.087×10^{-1} *				
300	1.091				
400	1.238				
500	1.314				
600	1.362				

* Not shown on plot

SPECIFIC HEAT OF
ALUMINUM ANTIMONIDE
AlSb

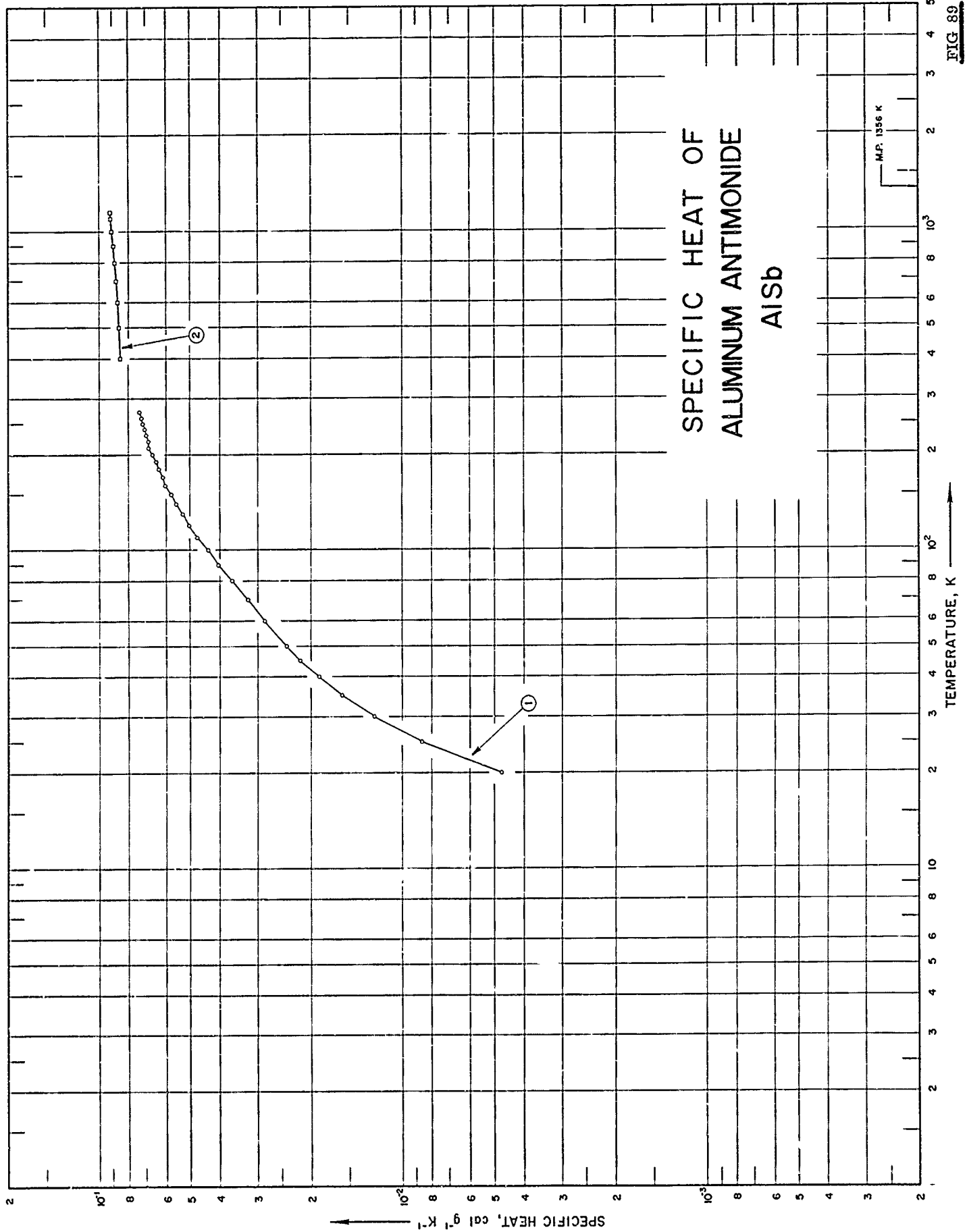

SPECIFICATION TABLE NO. 89 SPECIFIC HEAT OF ALUMINUM ANTIMONIDE AISb

[For Data Reported in Figure and Table No. 89]

Curve No.	Ref. No.	Year	Temp. Range, K	Reported Error, %	Name and Specimen Designation	Composition (weight percent), Specifications and Remarks
1	156	1963	20-273	≤2.0		
2	157	1963	400-1150			

~99.99 AISb.

DATA TABLE NO. 89 SPECIFIC HEAT OF ALUMINUM ANTIMONIDE AISb

[Temperature, T, K; Specific Heat, Cp, Cal g⁻¹ K⁻¹]

T	Cp
<u>CURVE 1</u>	
20	4.71 x 10 ⁻²
25	8.60
30	1.24 x 10 ⁻²
35	1.587
40	1.895
45	2.165
50	2.404
60	2.844
70	3.247
80	3.644
90	4.027
100	4.390
110	4.719
120	5.015
130	5.303
140	5.573
150	5.798
160	6.001
170	6.176
180	6.332
190	6.476
200	6.616
210	6.860
220	6.858
230	6.969
240	7.075
250	7.180
260	7.272
270	7.328*
273.2	7.342
<u>CURVE 2</u>	
400	8.458 x 10 ⁻²
500	8.5590
600	8.66
700	8.7608
800	8.8616
900	8.9624
1000	9.0634
1100	9.1642
1150	9.2146

* Not shown on plot

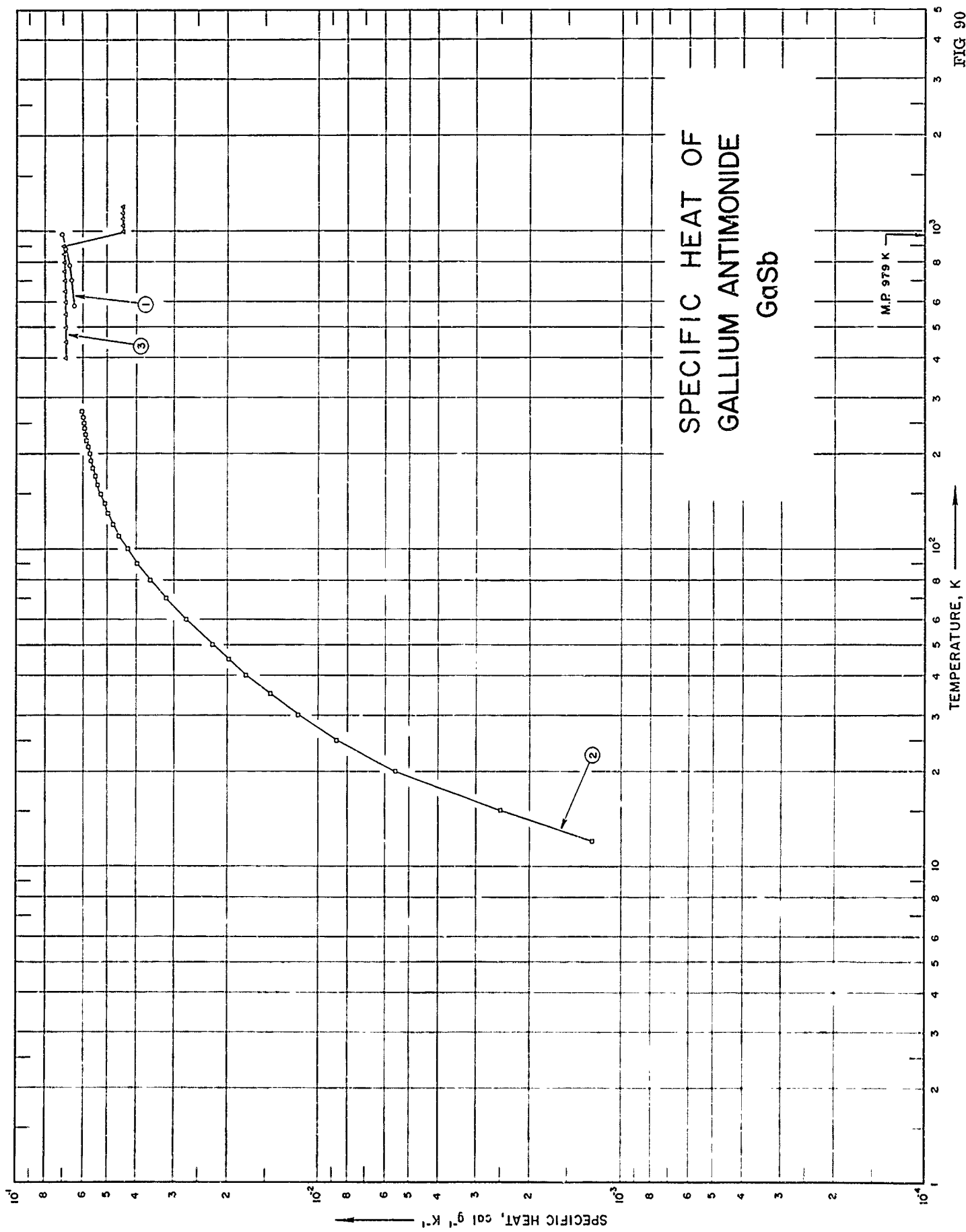

FIG 90

SPECIFICATION TABLE NO. 90 SPECIFIC HEAT OF GALLIUM ANTIMONIDE GaSb

[For Data Reported in Figure and Table No. 90]

Curve No.	Ref. No.	Year	Temp. Range, K	Reported Error, %	Name and Specimen Designation	Composition (weight percent), Specifications and Remarks
1	158	1961	586-980	≤0.2		99.99 GaSb; obtained by melting stoichiometric amounts of pure metals together in evacuated quartz ampules.
2	156	1963	12-273	≤2.0		
3	157	1963	400-1200			~99.99 GaSb.

DATA TABLE NO. 90 SPECIFIC HEAT OF GALLIUM ANTIMONIDE GaSb
 [Temperature, T, K; Specific Heat, C_p , Cal g⁻¹ K⁻¹]

T	C_p	T	C_p
		CURVE 3	
		(s)400	6.8302×10^{-2}
585.85	6.405×10^{-2}	450	6.8416
704.35	6.593	500	6.8532
785.05	6.721	550	6.8648
884.95	6.880	600	6.8764
980.35	7.032	650	6.8880
		700	6.8996
		750	6.9112
		800	6.9228
		850	6.9344
		(s)900	6.9460
		(1) 1000	4.4184×10^{-2}
		1050	4.4184
		1100	4.4184
		1150	4.4184
		(1) 1200	4.4184
		CURVE 2	
12	1.25×10^{-3}		
15	2.50		
20	5.54		
25	8.64		
30	1.167×10^{-2}		
35	1.441		
40	1.713		
45	1.974		
50	2.225		
60	2.716		
70	3.173		
80	3.591		
90	3.953		
100	4.257		
110	4.506		
120	4.726		
130	4.920		
140	5.087		
150	5.228		
160	5.343		
170	5.440		
180	5.529		
190	5.611		
200	5.688		
210	5.759		
220	5.818		
230	5.870		
240	5.909		
250	5.943		
260	5.975		
270	6.004*		
273.2	6.011		

* Not shown on plot

FIG 91

SPECIFIC HEAT OF INDIUM ANTIMONIDE InSb

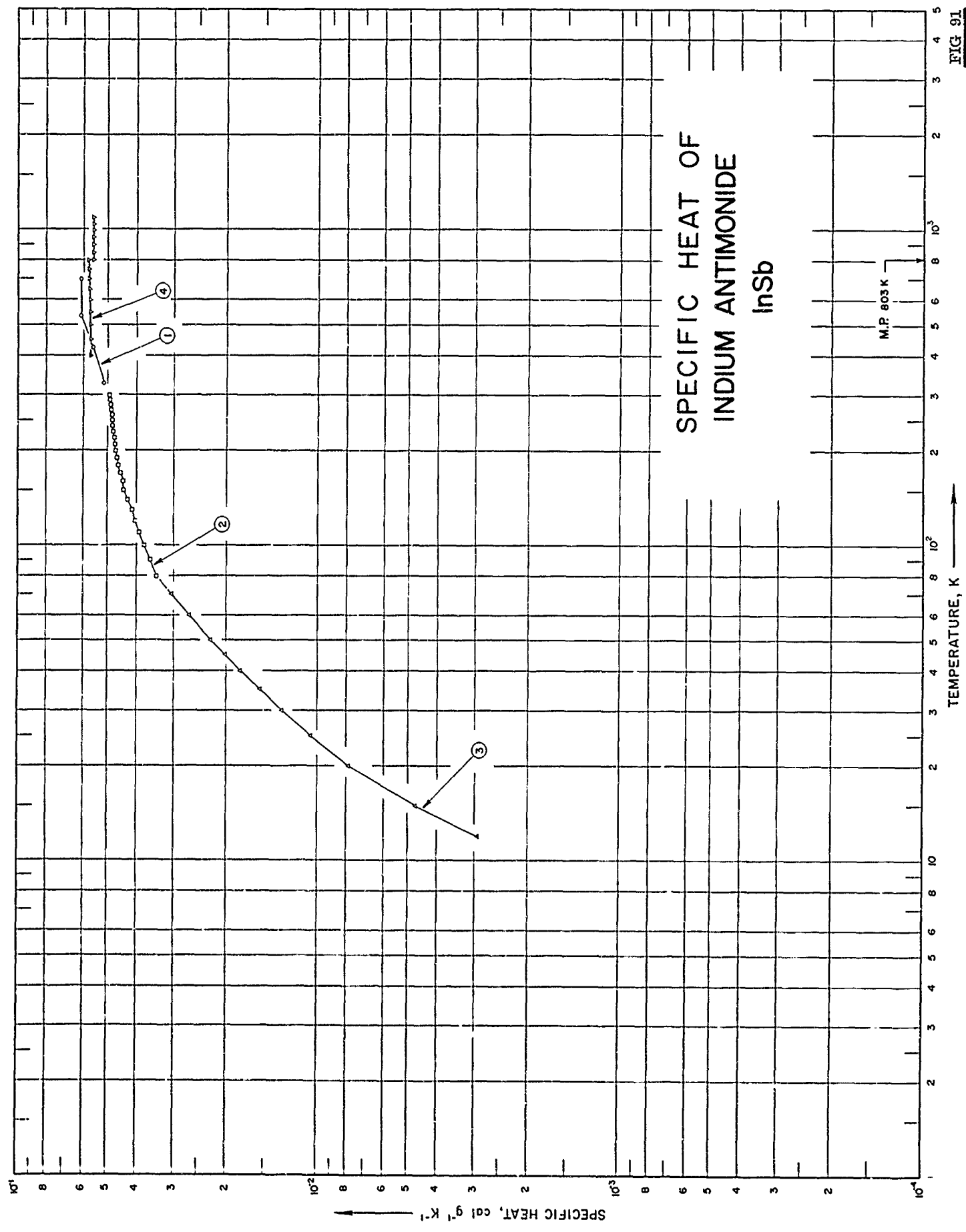

SPECIFICATION TABLE NO. 91 SPECIFIC HEAT OF INDIUM ANTIMONIDE InSb

[For Data Reported in Figure and Table No. 91]

Curve No.	Ref. No.	Year	Temp. Range, K	Reported Error, %	Name and Specimen Designation	Composition (weight percent), Specifications and Remarks
1	159	1958	328-698			51.44 Sb, 0.001 Fe, 0.001 Mg, 0.001 Pb, 0.001 Sn, 0.001 Cu, and 0.0001 Si.
2	160	1959	80-300	3-7		Polycrystalline.
3	156	1963	12-273	≤2		
4	157	1963	400-1100			~99.99 InSb.

DATA TABLE NO. 91 SPECIFIC HEAT OF INDIUM ANTIMONIDE InSb
 [Temperature, T, K; Specific Heat, C_p, Cal g⁻¹ K⁻¹]

T	C _p	T	C _p
<u>CURVE 1</u>			
328	5.2 x 10 ⁻²	80	3.382*
423	5.6	90	3.641*
533	6.2	100	3.851*
698	6.2	110	4.014*
		120	4.153*
		130	4.275*
		140	4.382*
		150	4.472*
		160	4.546*
		170	4.607*
		180	4.658*
		190	4.703*
		200	4.746*
		210	4.789*
		220	4.825*
		230	4.858*
		240	4.886*
		250	4.912*
		260	4.935*
		270	4.954*
		273.2	4.960*
		<u>CURVE 2</u>	
80	3.45 x 10 ⁻²		
90	3.63		
100	3.8		
110	3.95		
120	4.06		
130	4.19		
140	4.31		
150	4.4		
160	4.48		
170	4.56		
180	4.63		
190	4.68		
200	4.72		
210	4.76		
220	4.78		
230	4.82		
240	4.85		
250	4.86		
260	4.89		
270	4.91		
280	4.93		
290	4.95		
300	4.97		
		<u>CURVE 3</u>	
12	2.96 x 10 ⁻³	(s) 400	5.72 x 10 ⁻²
15	4.77	450	5.74
20	7.90	500	5.75
25	1.060 x 10 ⁻²	550	5.76
30	1.319	600	5.78
35	1.568	650	5.80
40	1.810	700	5.81
45	2.047	750	5.84
50	2.276	800	5.86
60	2.699		
70	3.070		
		<u>CURVE 4</u>	
		(l) 803	5.62 x 10 ⁻²
		850	5.62
		900	5.62
		950	5.62
		1000	5.62
		1050	5.62
		(l) 1100	5.62

* Not shown on plot

FIG. 92

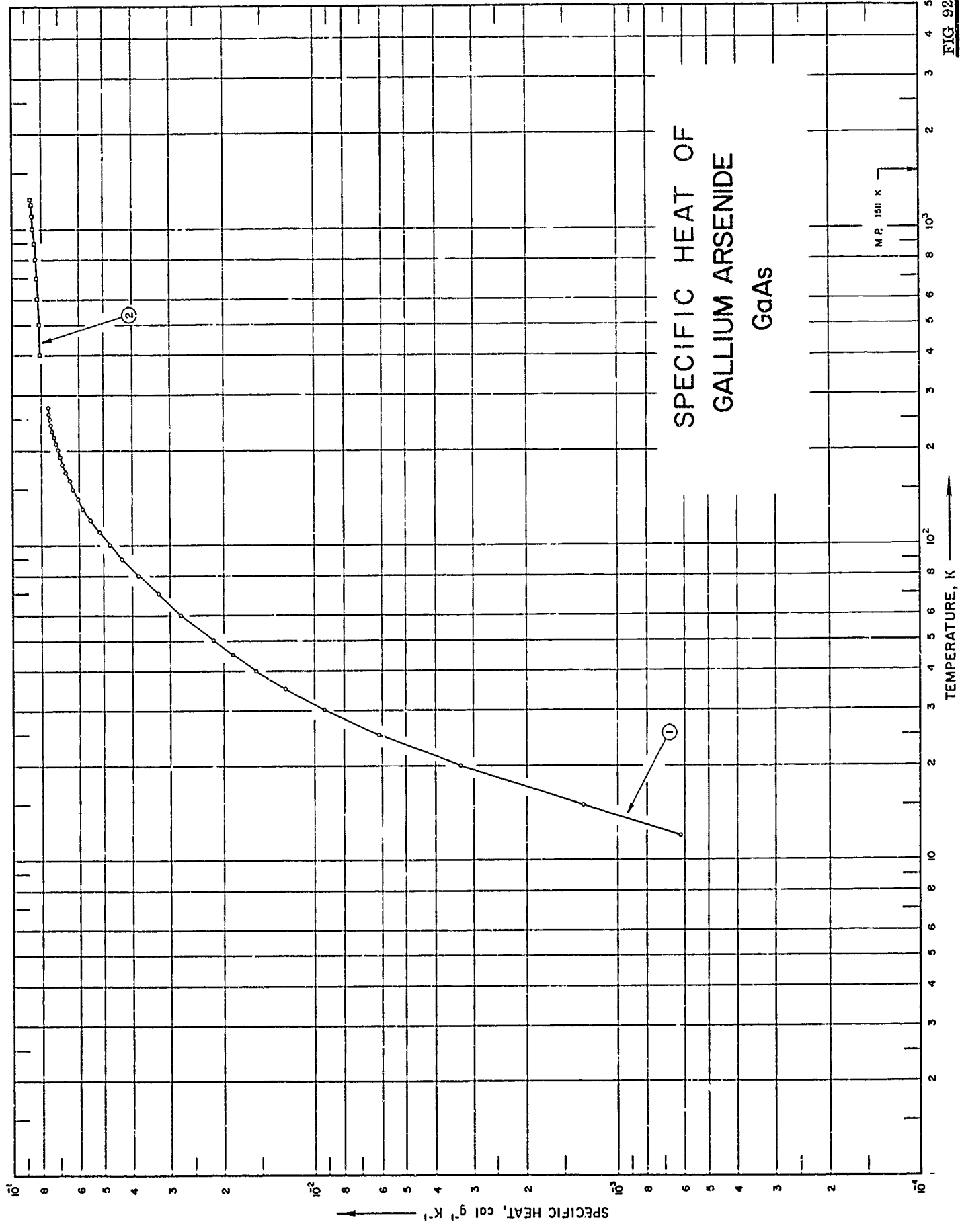

PRECEDING PAGE BLANK-NOT FILMED

SPECIFICATION TABLE NO. 92 SPECIFIC HEAT OF CALCIUM ARSENIDE GaAs

[For Data Reported in Figure and Table No. 92]

Curve No.	Ref. No.	Year	Temp. Range, K	Reported Error, %	Name and Specimen Designation	Composition (weight percent), Specifications and Remarks
1	156	1963	12-273	≤2		
2	157	1963	400-1250			~99.99 GaAs.

DATA TABLE NO. 92 SPECIFIC HEAT OF GALLIUM ARSENIDE GaAs

[Temperature, T, K; Specific Heat, C_p , Cal $g^{-1} K^{-1}$]

T	C_p
<u>CURVE 1</u>	
12	6.2×10^{-4}
15	1.3×10^{-3}
20	3.30
25	6.13
30	9.26
35	1.25×10^{-2}
40	1.563
45	1.866
50	2.160
60	2.731
70	3.291
80	3.821
90	4.317
100	4.768
110	5.158
120	5.501
130	5.801
140	6.080
150	6.303
160	6.495
170	6.658
180	6.804
190	6.942
200	7.069
210	7.181
220	7.283
230	7.365
240	7.436
250	7.495
260	7.536
270	7.575*
273.2	7.579
<u>CURVE 2</u>	
400	8.1012×10^{-2}
500	8.1734
600	8.2454
700	8.3176
800	8.3898
900	8.4620
1000	8.5342
1100	8.6064
1200	8.6786
1250	8.7146

*Not shown on plot

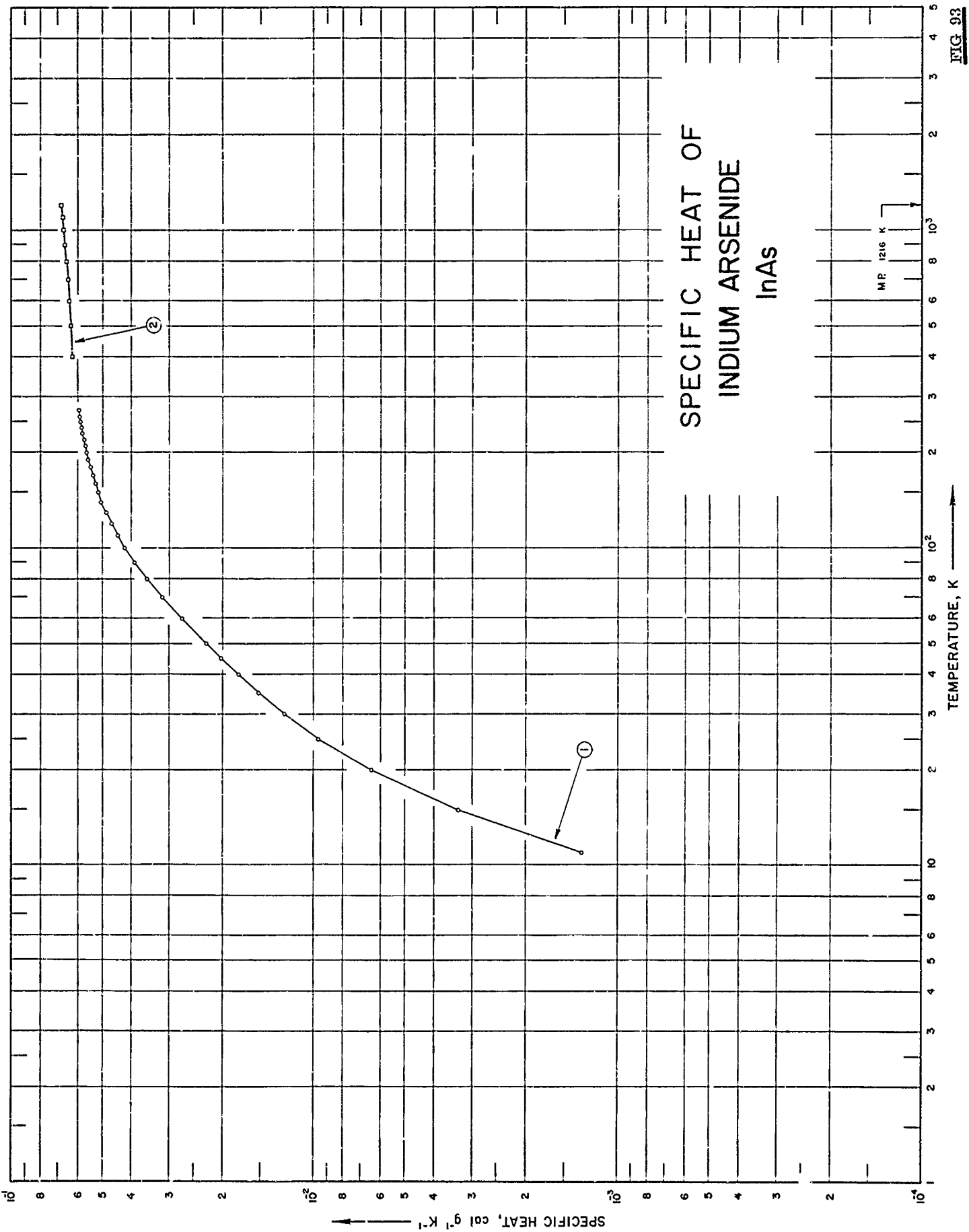

FIG. 93

SPECIFICATION TABLE NO. 93 SPECIFIC HEAT OF INDIUM ARSENIDE InAs

[For Data Reported in Figure and Table No. 93]

Curve No.	Ref. No.	Year	Temp. Range, K	Reported Error, %	Name and Specimen Designation	Composition (weight percent), Specifications and Remarks
1	156	1963	11-273	±2.0		99.99 InAs.
2	157	1963	400-1200			

DATA TABLE NO. 93 SPECIFIC HEAT OF INDIUM ARSENIIDE InAs

[Temperature, T, K; Specific Heat, Cp, Cal g⁻¹ K⁻¹]

T Cp

CURVE 1

T	Cp
11	1.318 x 10 ⁻³
15	3.331
20	6.472
25	9.614
30	1.252 x 10 ⁻²
35	1.522
40	1.775
45	2.022
50	2.266
60	2.730
70	3.162
80	3.552
90	3.906
100	4.212
110	4.470
120	4.684
130	4.874
140	5.027
150	5.174
160	5.292
170	5.395
180	5.481
190	5.556
200	5.627
210	5.692
220	5.750
230	5.808
240	5.861
250	5.905
260	5.942
270	5.970*
273.2	5.977

CURVE 2

T	Cp
400	6.2810 x 10 ⁻²
500	6.3518
600	6.4226
700	6.4934
800	6.5642
900	6.6352
1000	6.7060
1100	6.7768
1200	6.8476

* Not shown on plot

FIG. 94

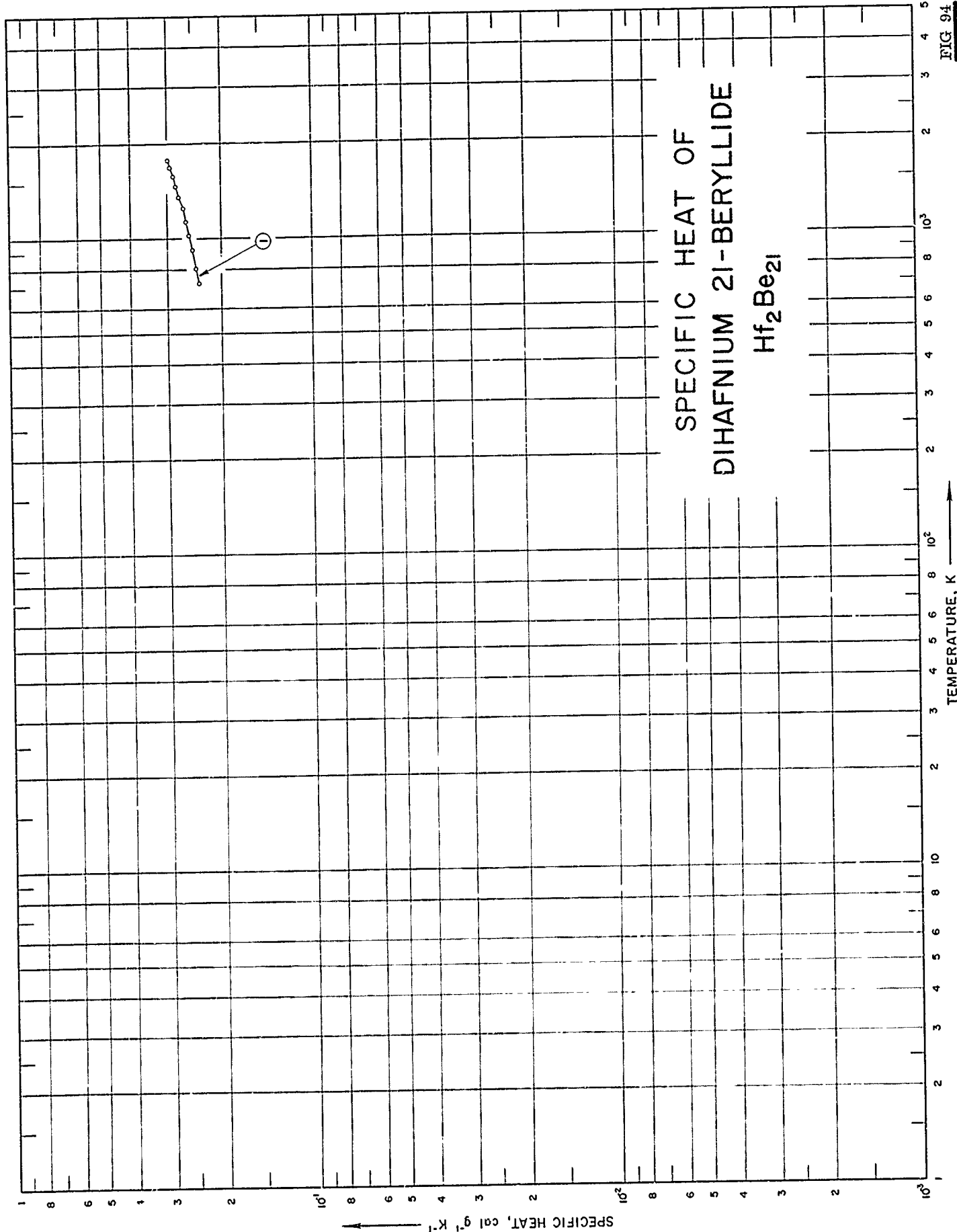

SPECIFICATION TABLE NO. 94 SPECIFIC HEAT OF DIHAFNIUM 21-BERYLLIDE $\text{Hf}_2\text{Be}_{21}$

[For Data Reported in Figure and Table No. 94]

Curve No.	Ref. No.	Year	Temp. Range, K	Reported Error, %	Name and Specimen Designation	Composition (weight percent), Specifications and Remarks
1	162	1961	728-1783			34.1 Be; hot pressed.

DATA TABLE NO. 94 SPECIFIC HEAT OF DIHAFNIUM 21-BERYLLIDE $\text{Hf}_2\text{Be}_{21}$
 [Temperature, T, K; Specific Heat, C_p , Cal $\text{g}^{-1}\text{K}^{-1}$]

T	C_p
<u>CURVE 1</u>	
727.594	2.341 x 10 ⁻¹
810.928	2.390
922.039	2.455
1033.150	2.520
1144.261	2.585
1255.372	2.649
1366.483	2.714
1477.594	2.779
1588.705	2.844
1699.817	2.909
1783.150	2.957

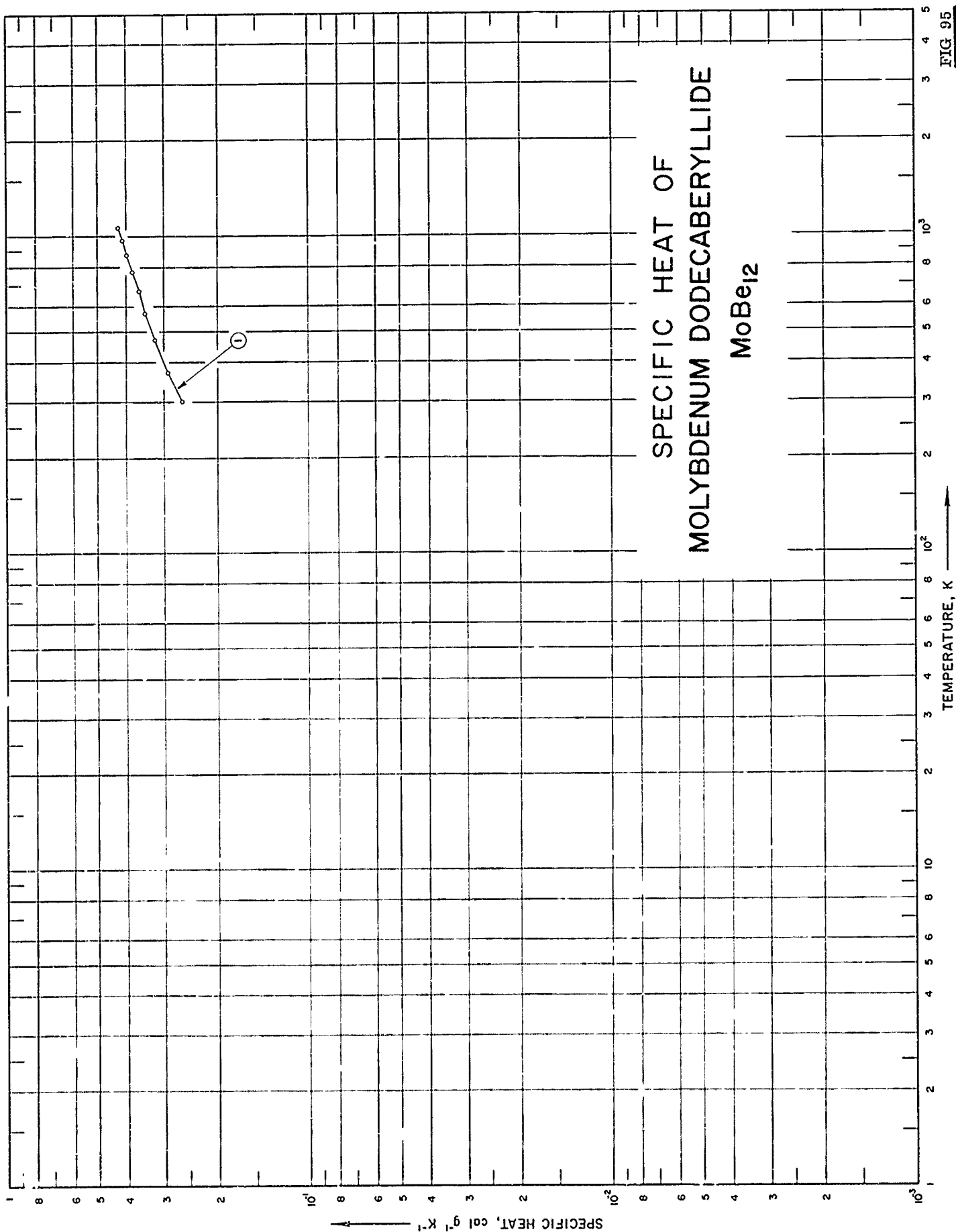

FIG 95

SPECIFICATION TABLE NO. 95 SPECIFIC HEAT OF MOLYBDENUM DODECABERYLLIDE MoBe₂

[For Data Reported in Figure and Table No. 95]

Curve No.	Ref. No.	Year	Temp. Range, K	Reported Error, %	Name and Specimen Designation	Composition (weight percent), Specifications and Remarks
1	45	1963	303-1073	<3		

DATA TABLE NO. 95 SPECIFIC HEAT OF MOLYBDENUM DODECABERYLLIDE MoBe_{12} [Temperature, T, K; Specific Heat, C_p , Cal $\text{g}^{-1}\text{K}^{-1}$]

T	C_p
<u>CURVE 1</u>	
303.15	2.61×10^{-1}
373.15	2.93
473.15	3.22
573.15	3.46
673.15	3.64
773.15	3.81
873.15	3.98
973.15	4.13
1073.15	4.28

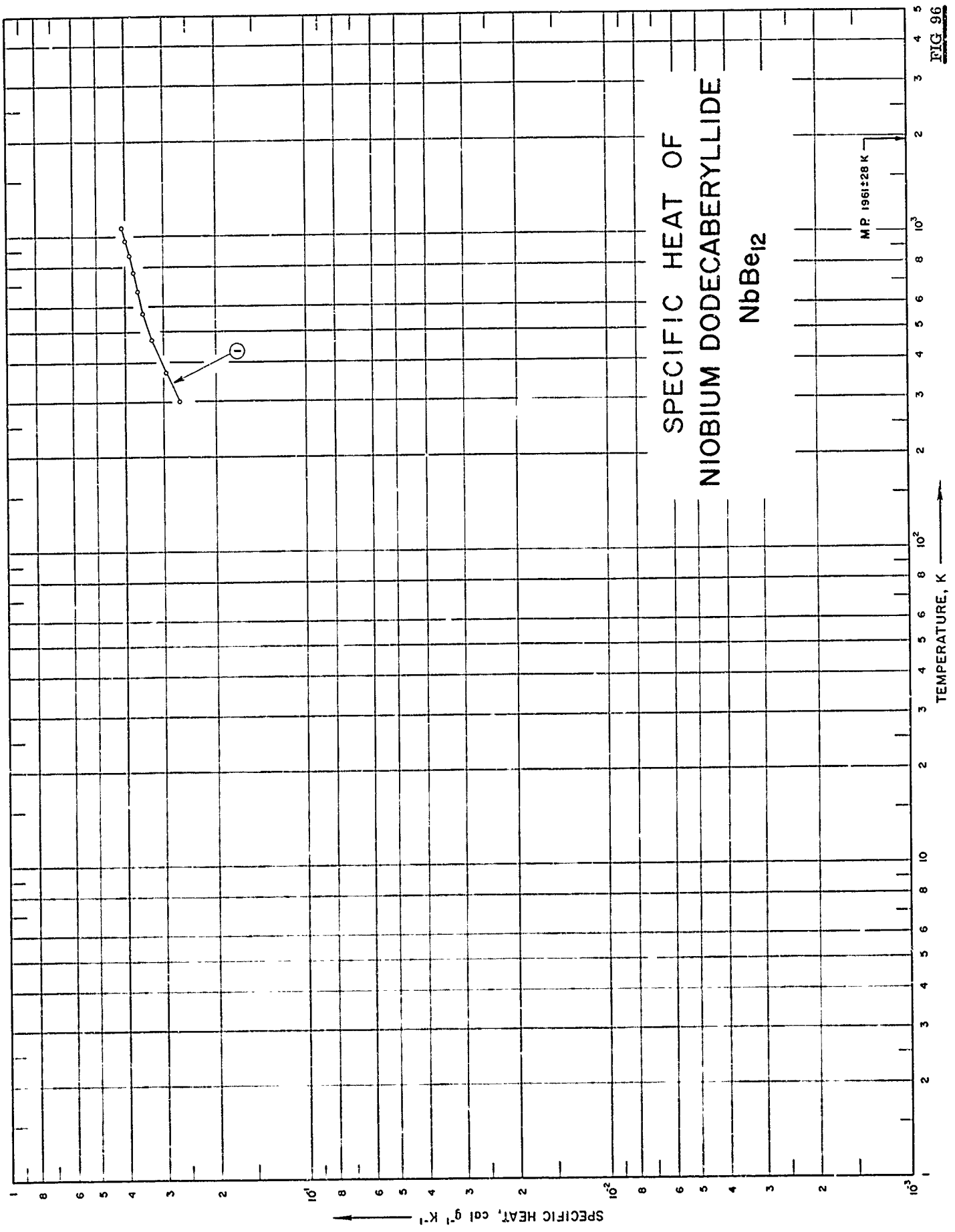

SPECIFICATION TABLE NO. 96 SPECIFIC HEAT OF NIOBIUM DODECABERYLLIDE NbBe₁₂

[For Data Reported in Figure and Table No. 96]

Curve No.	Ref. No.	Year	Temp. Range, K	Reported Error, %	Name and Specimen Designation	Composition (weight percent), Specifications and Remarks
1	45	1962	303-1073	<3		

DATA TABLE NO. 96 SPECIFIC HEAT OF NIOBIUM DODECABERYLLIDE NbBe₁₂
[Temperature, T, K; Specific Heat, C_p, Cal g⁻¹K⁻¹]

T	C _p
<u>CURVE 1</u>	
303.15	2.65 x 10 ⁻¹
373.15	2.94
473.15	3.27
573.15	3.50
673.15	3.65
773.15	3.76
873.15	3.87
973.15	4.00
1073.15	4.11

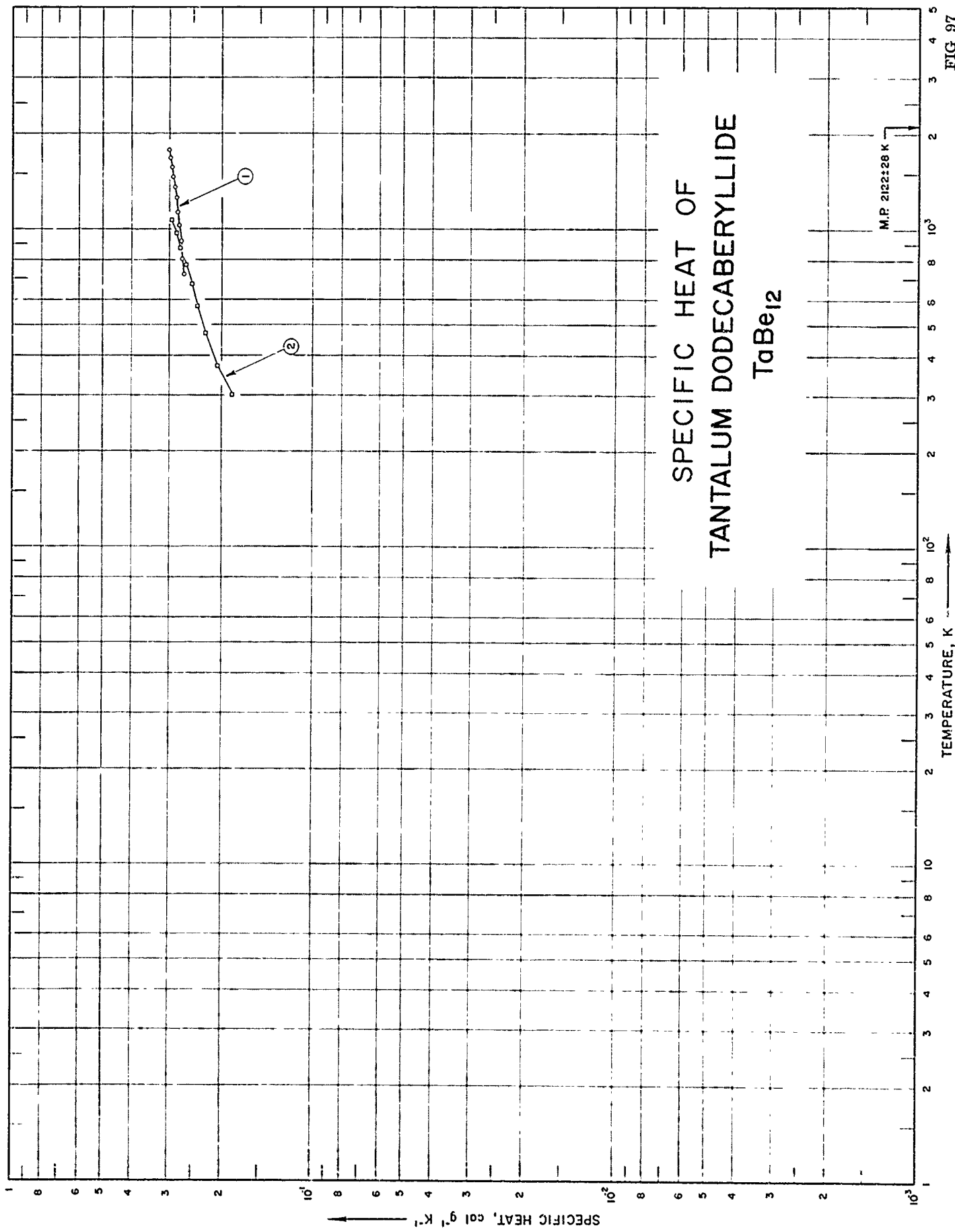

FIG 97

SPECIFICATION TABLE NO. 97 SPECIFIC HEAT OF TANTALUM DODECABERYLLIDE TaBe₁₂

[For Data Reported in Figure and Table No. 97]

Curve No.	Ref. No.	Year	Temp. Range, K	Reported Error, %	Name and Specimen Designation	Composition (weight percent), Specifications and Remarks
1	162	1961	728-1783			Single phase composition; hot pressed.
2	45	1962	303-1073	<3		

DATA TABLE NO. 97 SPECIFIC HEAT OF TANTALUM DODECABERYLLIDE TaBe₁₂[Temperature, T, K; Specific Heat, C_p, Cal g⁻¹K⁻¹]

T	C _p
<u>CURVE 1</u>	
727.60	2.6806 x 10 ⁻¹
810.90	2.7060
922.02	2.7398
1033.16	2.7735
1144.27	2.8073
1255.38	2.8411
1366.49	2.8749
1477.60	2.9087
1588.72	2.9425
1699.83	2.9763
1783.16	3.0016
<u>CURVE 2</u>	
303.15	1.85 x 10 ⁻¹
373.15	2.07
473.15	2.27
573.15	2.41
673.15	2.53
773.15	2.64
873.15	2.75
973.15	2.84
1073.15	2.95

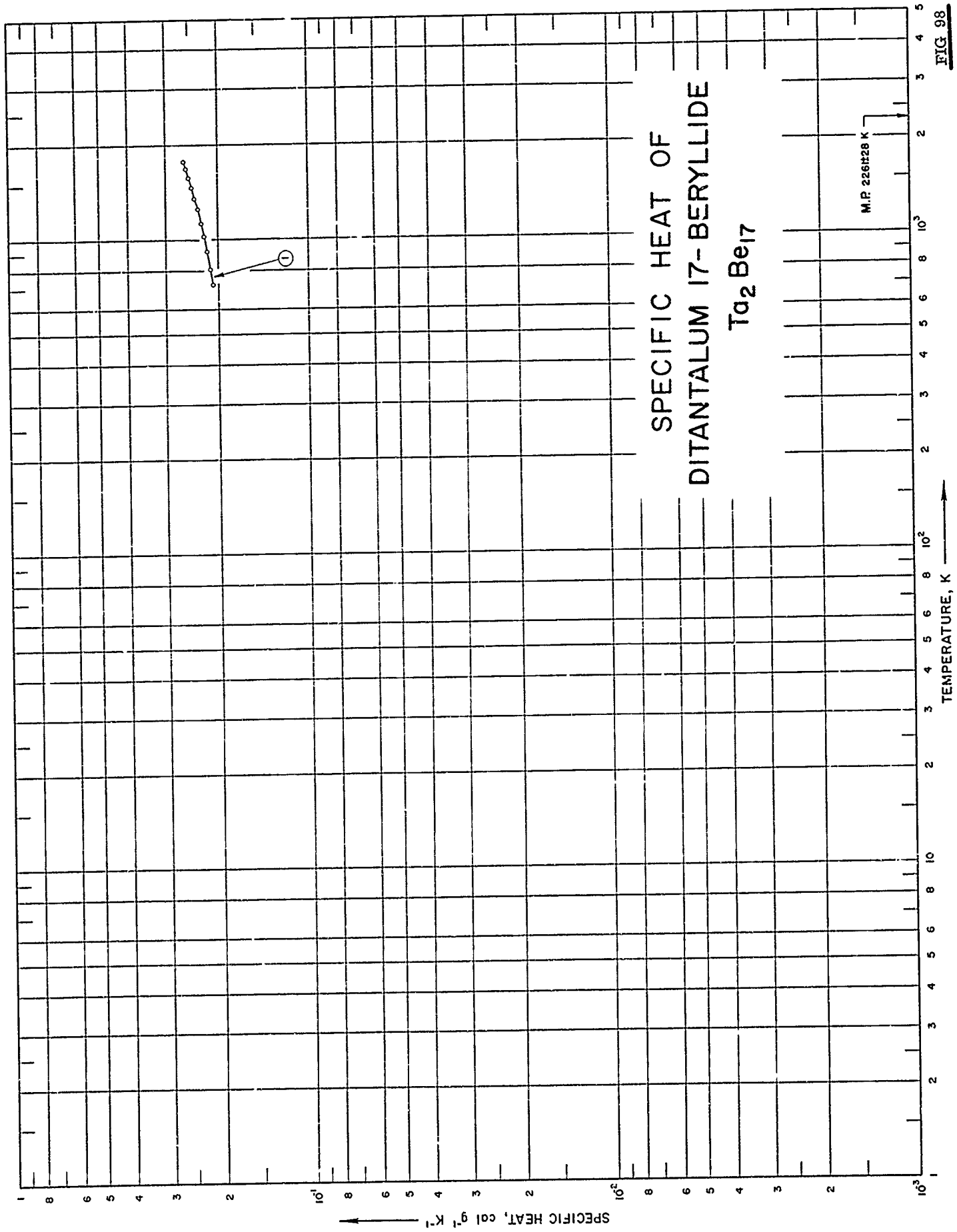

SPECIFICATION TABLE NO. 98 SPECIFIC HEAT OF DITANTALUM 17-BERYLLIDE Ta₂Be₁₇

[For Data Reported in Figure and Table No. 98]

Curve No.	Ref. No.	Year	Temp. Range, K	Reported Error, %	Name and Specimen Designation	Composition (weight percent), Specifications and Remarks
1	162	1961	728-1783			Single phase composition; hot pressed.

DATA TABLE NO. 98 SPECIFIC HEAT OF DITANTALUM 17-BERYLLIDE Ta₂Be₁₇
 [Temperature, T, K; Specific Heat, C_p, Cal g⁻¹K⁻¹]

T	C _p
	<u>CURVE 1</u>
727.60	2.0930 x 10 ⁻¹
810.90	2.1330
922.02	2.1864
1033.16	2.2398
1144.27	2.2932
1255.38	2.3466
1366.49	2.4000
1477.60	2.4534
1588.72	2.5068
1699.82	2.5603
1783.16	2.6003

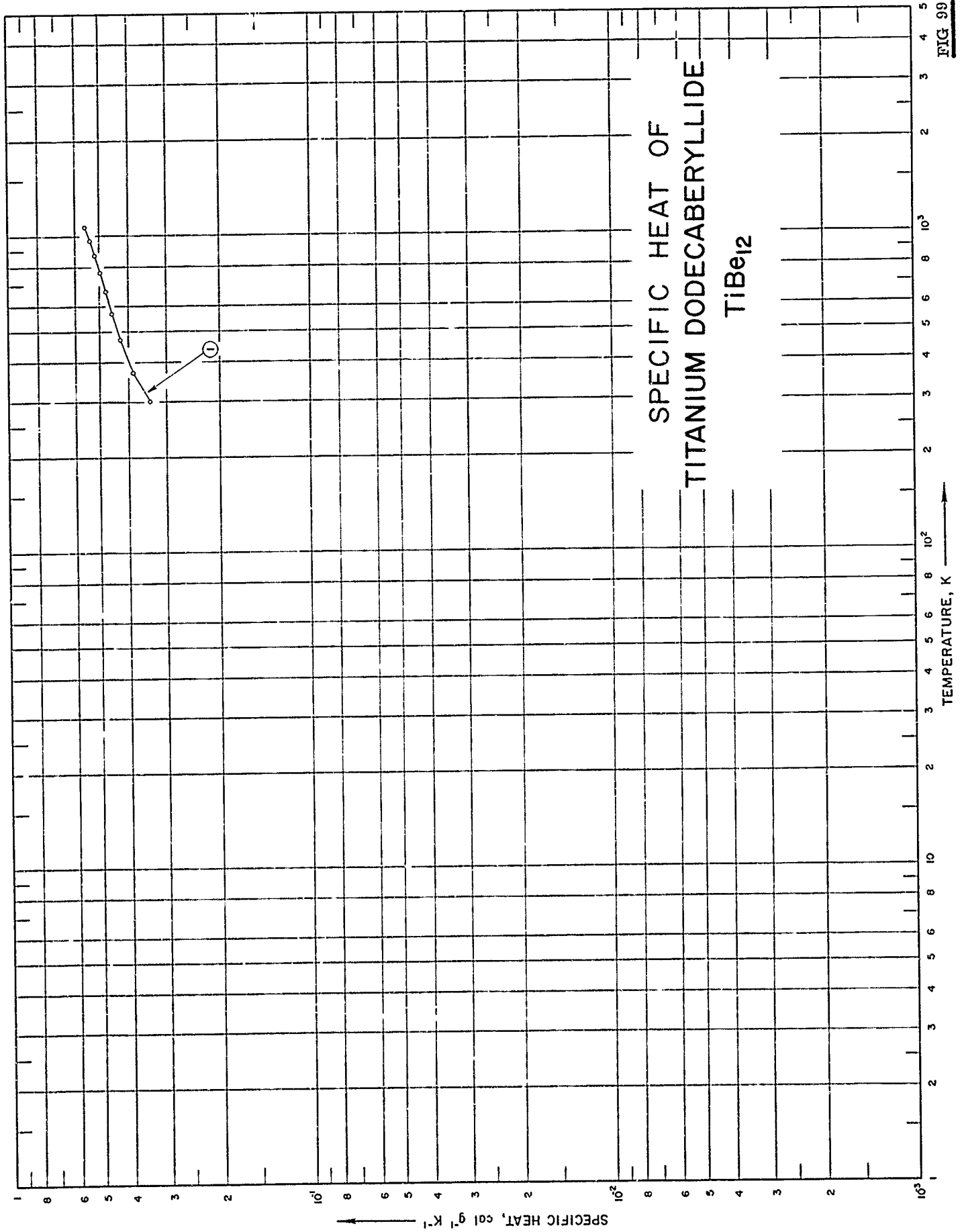

FIG 99

SPECIFICATION TABLE NO. 99 SPECIFIC HEAT OF TITANIUM DODECABERYLLIDE $TiBe_{12}$

[For Data Reported in Figure and Table No. 99]

Curve No.	Ref. No.	Year	Temp. Range, K	Reported Error, %	Name and Specimen Designation	Composition (weight percent), Specifications and Remarks
1	45	1963	303-1073	<3		

DATA TABLE NO. 99 SPECIFIC HEAT OF TITANIUM DODECABERYLLIDE TiBe_{12}
[Temperature, T, K; Specific Heat, C_p , $\text{Cal g}^{-1}\text{K}^{-1}$]

T	C_p
CURVE 1	
303.15	3.41×10^{-1}
373.15	3.86
473.15	4.28
573.15	4.54
673.15	4.76
773.15	4.97
873.15	5.17
973.15	5.37
1073.15	5.57

FIG 100

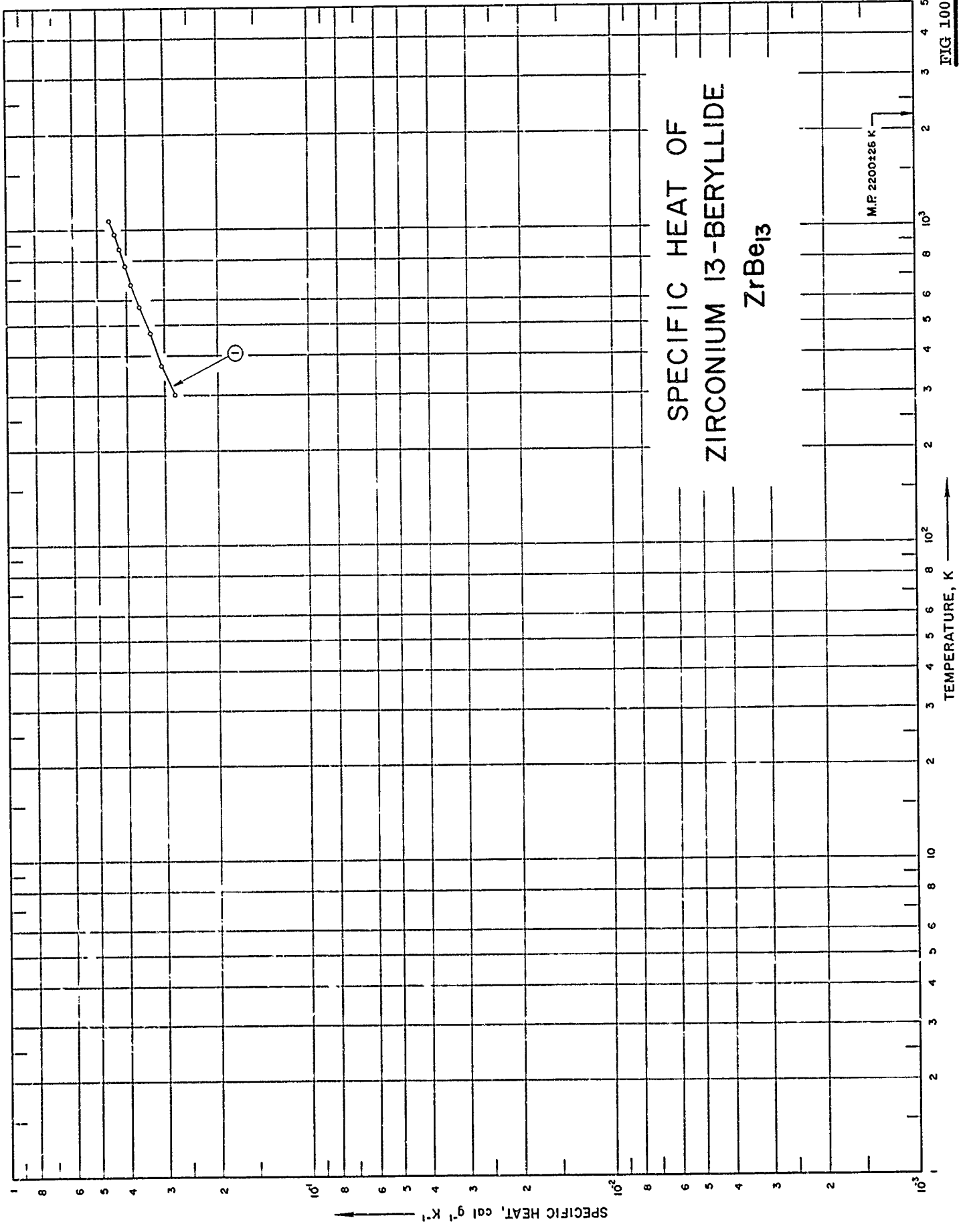

SPECIFICATION TABLE NO. 100 SPECIFIC HEAT OF ZIRCONIUM 13-BERYLLIDE $ZrBe_{13}$

[For Data Reported in Figure and Table No. 100]

Curve No.	Ref. No.	Year	Temp. Range, K	Reported Error, %	Name and Specimen Designation	Composition (weight percent), Specifications and Remarks
1	45	1962	303-1073	<3		

DATA TABLE NO. 100 SPECIFIC HEAT OF ZIRCONIUM 13-BERYLLIDE ZrBe_{13}
[Temperature, T, K; Specific Heat, C_p , Cal $\text{g}^{-1}\text{K}^{-1}$]

T	C_p
CURVE 1	
303.15	2.76×10^{-1}
373.15	3.07
473.15	3.38
573.15	3.63
673.15	3.85
773.15	4.03
873.15	4.20
973.15	4.37
1073.15	4.54

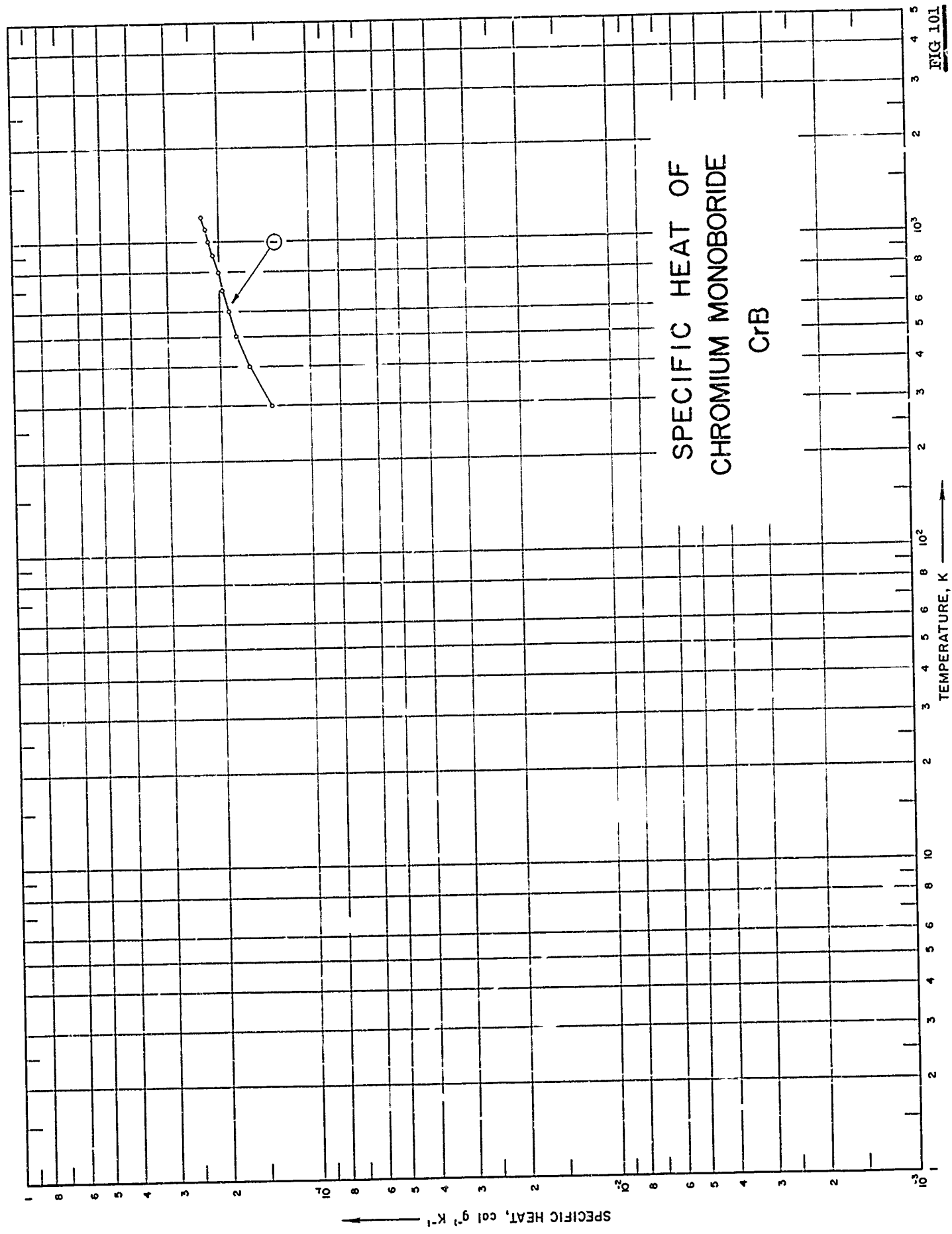

SPECIFIC HEAT OF
CHROMIUM MONOBORIDE
CrB

FIG 101

PRECEDING PAGE BLANK-NOT FILMED

SPECIFICATION TABLE NO. 101 SPECIFIC HEAT OF CHROMIUM MONOBORIDE CrB

[For Data Reported in Figure and Table No. 101]

Curve No.	Ref. No.	Year	Temp. Range, K	Reported Error, %	Name and Specimen Designation	Composition (weight percent), Specifications and Remarks
1	163	1962	298-1200	0.5		Traces of impurities.

DATA TABLE NO. 101 SPECIFIC HEAT OF CHROMIUM MONOBORIDE CrB
[Temperature, T, K; Specific Heat, C_p , Cal $g^{-1} K^{-1}$]

T	C_p
<u>CURVE 1</u>	
298.16	1.364×10^{-1}
300	1.371*
400	1.618
500	1.764
600	1.872
700	1.962
800	2.040
900	2.113
1000	2.183
1100	2.250
1200	2.315

* Not shown on plot

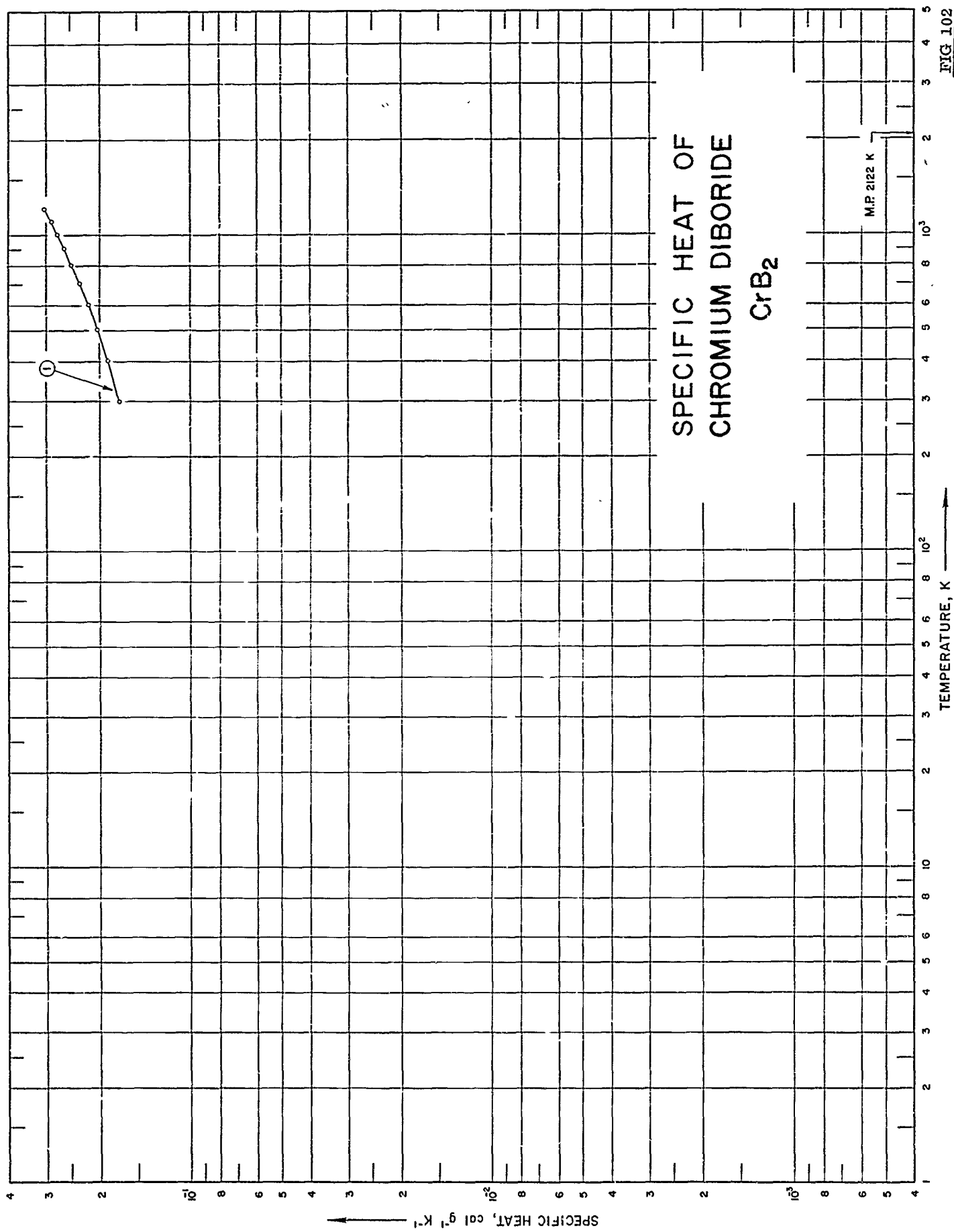

FIG 102

SPECIFICATION TABLE NO. 102 SPECIFIC HEAT OF CHROMIUM DIBORIDE CrB_2

[For Data Reported in Figure and Table No. 102]

Curve No.	Ref. No.	Year	Temp. Range, K	Reported Error, %	Name and Specimen Designation	Composition (weight percent), Specifications and Remarks
1	163	1962	298-1200			Traces of impurities.

DATA TABLE NO. 102 SPECIFIC HEAT OF CHROMIUM DIBORIDE CrB_2 [Temperature, T, K; Specific Heat, C_p , Cal $\text{g}^{-1} \text{K}^{-1}$]

T	C_p
	<u>CURVE 1</u>
298.16	1.738 x 10^{-1}
300	1.743*
400	1.888
500	2.033
600	2.179
700	2.326
800	2.471
900	2.616
1000	2.762
1100	2.907
1200	3.054

* Not shown on plot

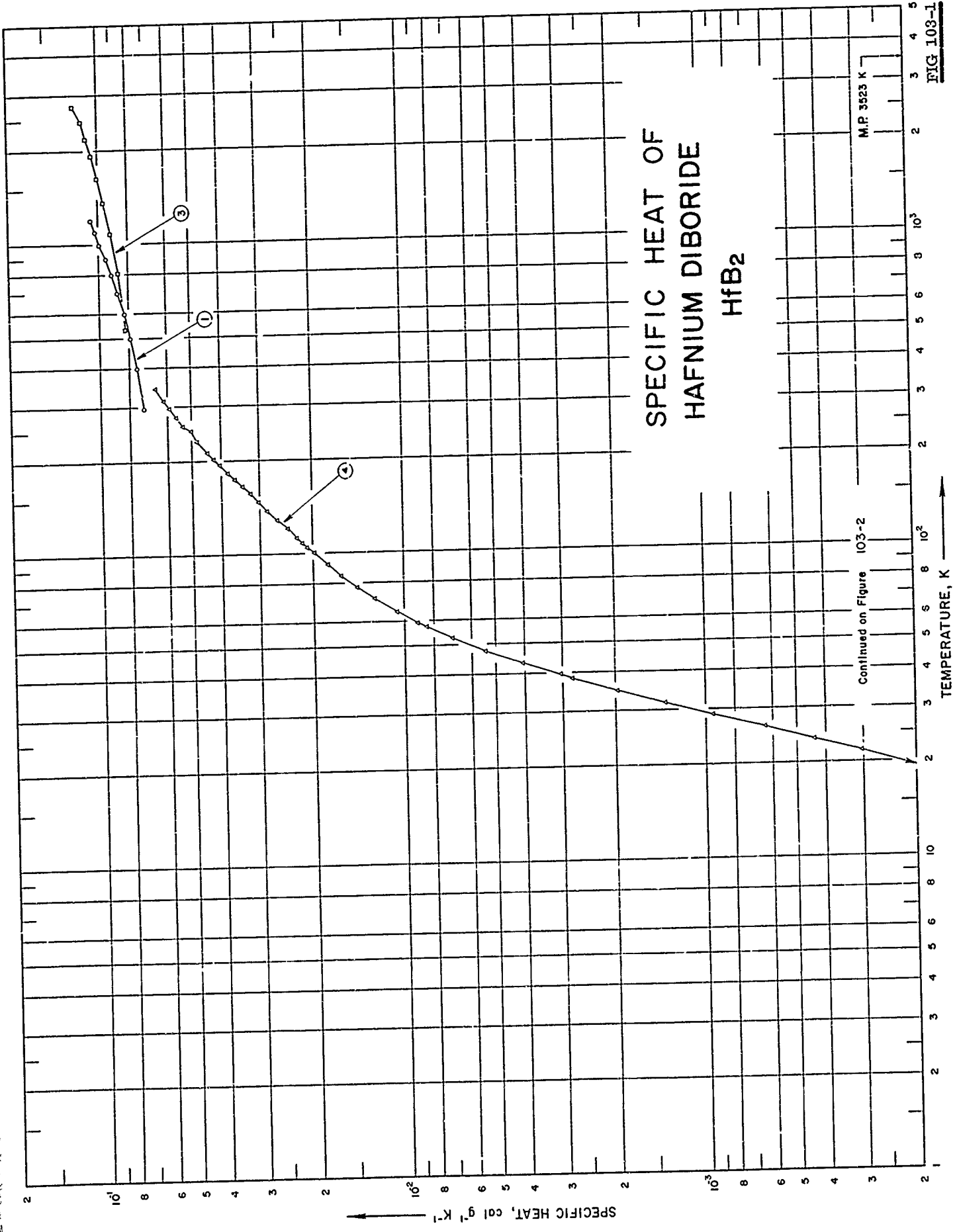

FIG 103-1

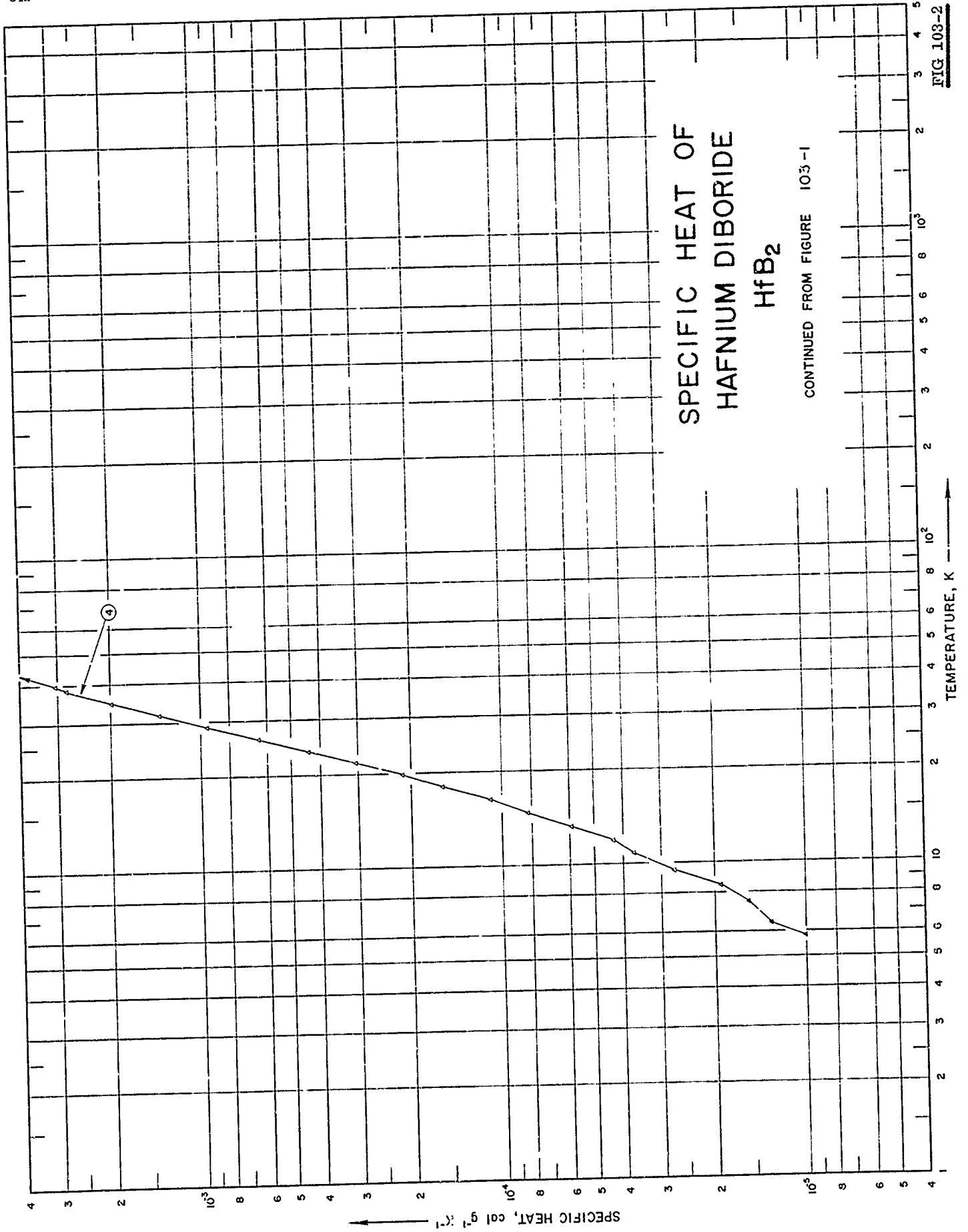

FIG 103-2

SPECIFICATION TABLE NO. 103 SPECIFIC HEAT OF HAFNIUM DIBORIDE HfB₂

[For Data Reported in Figure and Table No. 103]

Curve No.	Ref. No.	Year	Temp. Range, K	Reported Error, %	Name and Specimen Designation	Composition (weight percent), Specifications and Remarks
1	163	1962	298-1200	0.5		Traces of impurities. Single phase composition; sample supplied by the Carborundum Co. Before exposure: 89.5 Hf, 10.0 B, 3.5 Fe, 1.5 Zr, 0.1 Mg, 0.1 Ti, and 0.01 C; after exposure: 89.4 Hf, 10.5 B, and 0.77 C; sample supplied by the Carborundum Co; crushed in a hardened steel mortar to pass 100-mesh screen; hot pressed; density at 25 C, before exposure; apparent density (ASTM method B311-58) 666 lb ft ⁻³ , true density (by immersion in xylene) 674 lb ft ⁻³ , after exposure: apparent density 629 lb ft ⁻³ , true density, 641 lb ft ⁻³ . 88.98 Hf, 10.97 B, 0.16 C, 0.01 - 0.1 Zr, 0.001 Cr, 0.001 Cu, 0.001 Mg, 0.0042 N, 0.0030 Fe, 0.0030 Ti, 0.0026 O, and 0.0010 Si; zone-refined.
2	164	1962	500-1200			
3	48	1962	533-2755	±5		
4	165	1963	5-345			

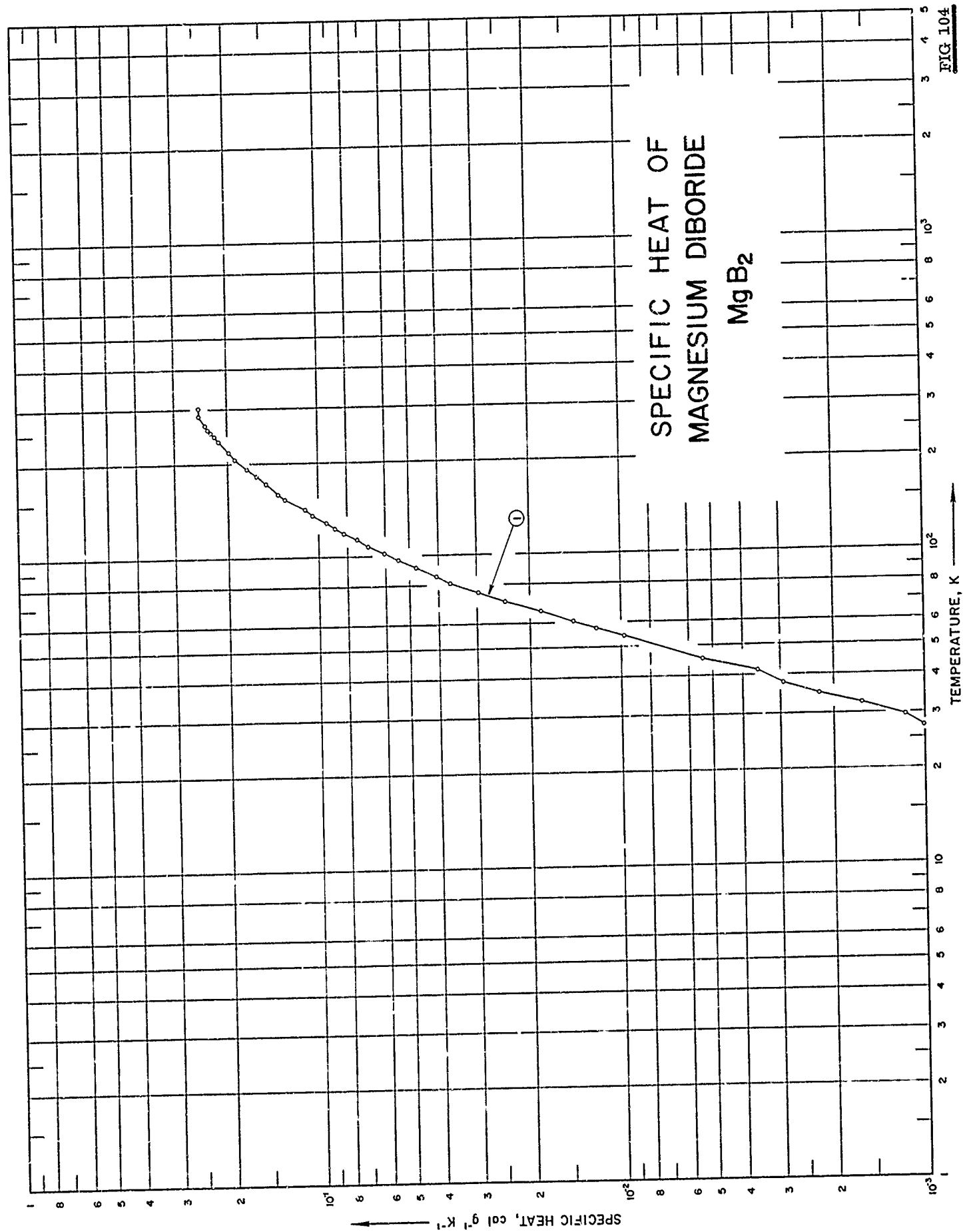

FIG 104

SPECIFICATION TABLE NO. 104 SPECIFIC HEAT OF MAGNESIUM DIBORIDE MgB_2

[For Data Reported in Figure and Table No. 104]

Curve No.	Ref. No.	Year	Temp. Range, K	Reported Error, %	Name and Specimen Designation	Composition (weight percent), Specifications and Remarks
1	166, 167	1956	21-304			93.90 MgB_2 , 3.69 B, 1.08 MgB_4 , 0.73 MgO , 0.46 Mg and 0.14 other impurities; prepared by heating stoichiometric amounts of Mg and B 3 hrs at 900 ± 25 C in helium atmosphere; corrected for impurities.

DATA TABLE NO. 104 SPECIFIC HEAT OF MAGNESIUM DIBORIDE MgB_2 [Temperature, T, K; Specific Heat, C_p , Cal $g^{-1} K^{-1}$]

T	C_p	T	C_p
CURVE 1		CURVE 1 (cont.)	
21.12	2.177×10^{-4} *	183.37	1.614×10^{-1}
23.05	4.789*	208.21	1.871*
25.06	7.402*	248.39	2.220
27.19	1.001×10^{-3}	279.19	2.449*
29.66	1.154	300.14	2.484*
32.41	1.611	237.71	2.184*
34.92	2.242	238.69	2.151*
37.75	2.917	254.87	2.266
41.37	3.549	287.69	2.475*
45.43	5.399	304.22	2.489*
54.12	9.797	304.06	2.487
57.42	1.206×10^{-2}		
60.99	1.439		
65.42	1.848		
70.26	2.412		
75.60	2.950		
81.29	3.666		
85.52	4.073		
91.29	4.763		
97.04	5.410		
102.83	6.065		
108.58	6.869		
114.13	7.448		
119.20	8.201		
124.40	8.802		
129.79	9.403		
293.42	2.486×10^{-1} *		
136.05	1.050		
140.35	1.104		
154.92	1.287		
173.53	1.494		
194.73	1.736		
219.27	1.980		
236.77	2.146*		
238.63	2.118		
246.14	2.201*		
253.63	2.304		
259.61	2.328		
266.88	2.367*		
274.04	2.424		
286.69	2.485		
298.81	2.502*		
26.44	1.263×10^{-3} *		
128.41	9.575×10^{-2} *		
145.03	1.168×10^{-1} *		
160.29	1.364		

* Not shown on plot

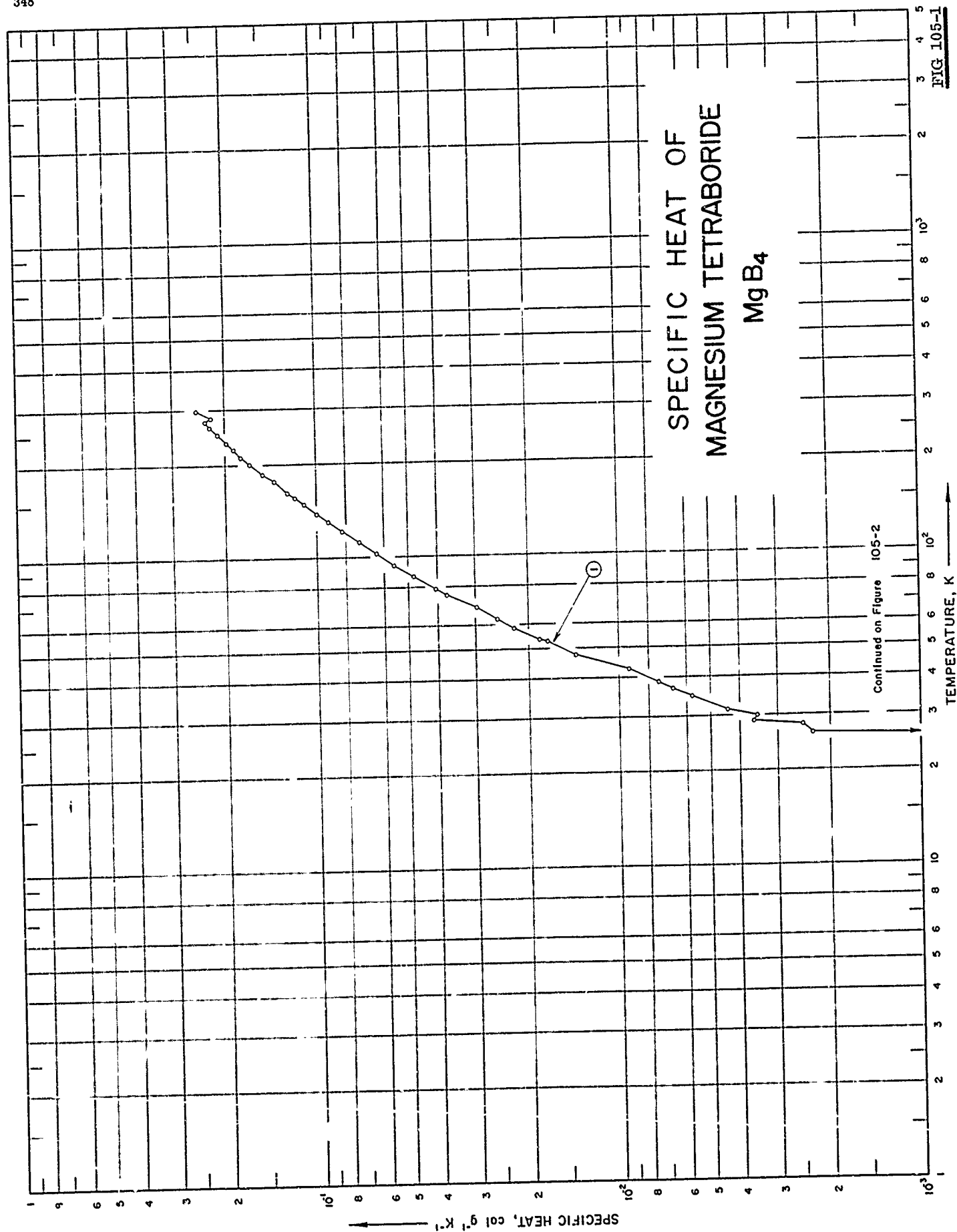

SPECIFIC HEAT OF MAGNESIUM TETRABORIDE MgB₄

CONTINUED FROM FIGURE 105-1

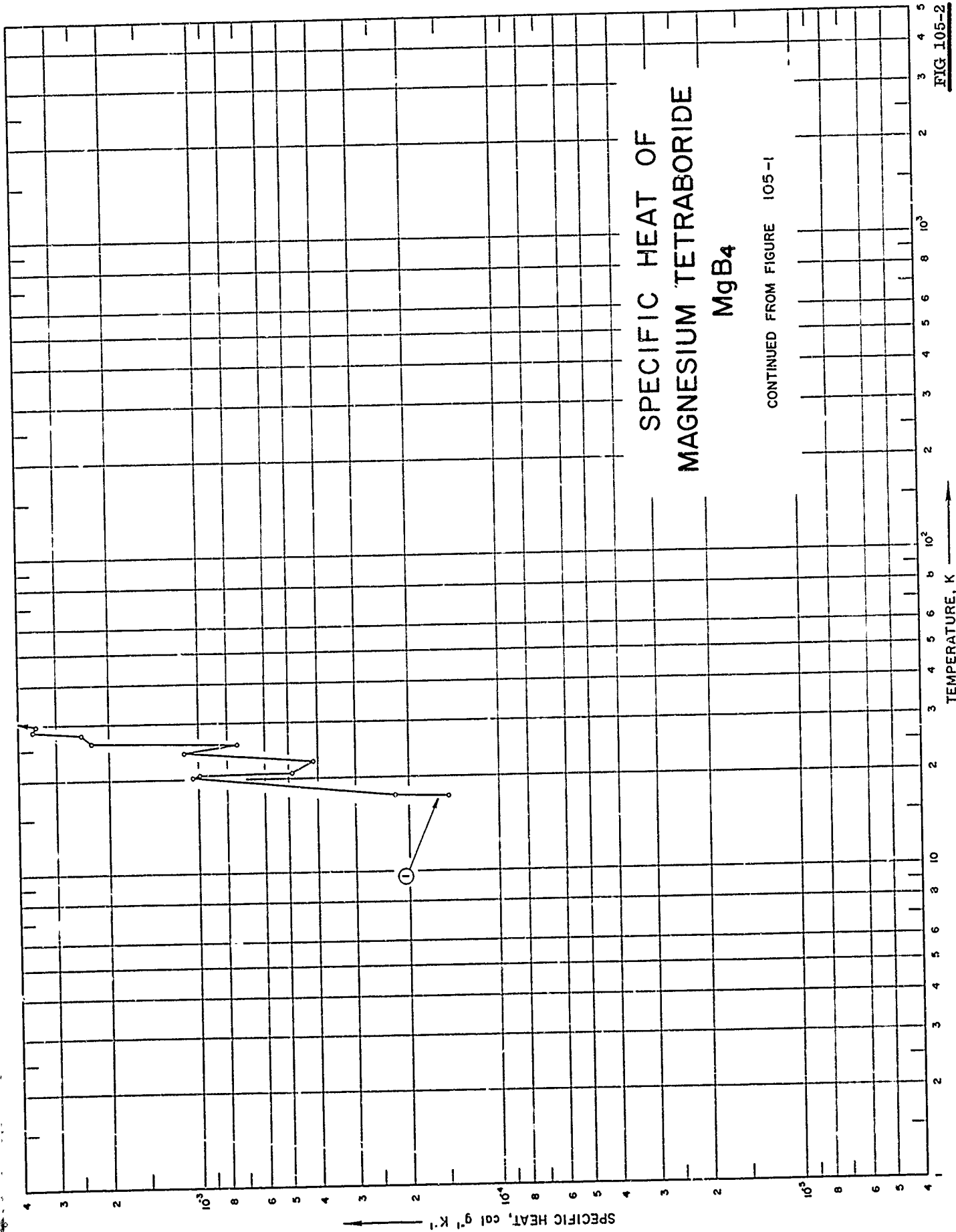

SPECIFICATION TABLE NO. 105 SPECIFIC HEAT OF MAGNESIUM TETRABORIDE MgB_4

[For Data Reported in Figure and Table No. 105]

Curve No.	Ref. No.	Year	Temp. Range, K	Reported Error, %	Name and Specimen Designation	Composition (weight percent), Specifications and Remarks
1	166, 167	1956	17-300			89.42 MgB_4 , 10.32 B, and 0.25 other impurities; prepared by heating stoichiometric amounts of Mg and B 3 hrs at 900 ± 25 C in helium atmosphere; corrected for impurities.

DATA TABLE NO. 105 SPECIFIC HEAT OF MAGNESIUM TETRABORIDE MgB₄[Temperature, T, K; Specific Heat, C_p, Cal g⁻¹ K⁻¹]

T	C _p	T	C _p
17.34	1.480 x 10 ⁻⁴	201.24	1.652 x 10 ⁻¹
17.52	2.220	212.85	1.776
20.29	1.051 x 10 ⁻³	220.17	1.762*
20.56	9.918 x 10 ⁻⁴	225.01	1.872
20.73	4.885	225.11	1.931*
22.66	4.145	235.27	1.971
24.38	1.125 x 10 ⁻³	242.98	2.038*
25.83	7.401 x 10 ⁻⁴	251.01	2.116
26.26	2.294 x 10 ⁻³	257.37	2.163*
27.94	2.472	265.74	2.247
28.72	3.597	267.17	2.252*
29.82	3.508	271.52	2.293*
31.45	4.382	276.60	2.326
34.55	5.729	280.31	2.359*
36.82	6.646	281.27	2.448*
38.53	7.431	283.39	2.223
42.77	9.296	284.62	2.419*
47.81	1.397 x 10 ⁻²	285.26	2.410*
52.96	1.739	290.41	2.433*
53.71	1.843	295.49	2.469*
58.32	2.234	299.53	2.490
62.81	2.542		
68.65	2.977		
69.03	3.008*		
75.11	3.732		
75.69	3.684*		
78.84	4.062		
86.28	4.790		
94.01	5.551		
103.08	6.347		
112.87	7.237		
121.84	8.200		
130.84	9.132		
139.20	9.977		
149.05	1.100 x 10 ⁻¹		
154.62	1.154*		
155.81	1.180		
162.66	1.249		
169.74	1.313*		
177.27	1.380		
179.64	1.376*		
187.17	1.499*		
189.99	1.512*		

*Net shown on plot

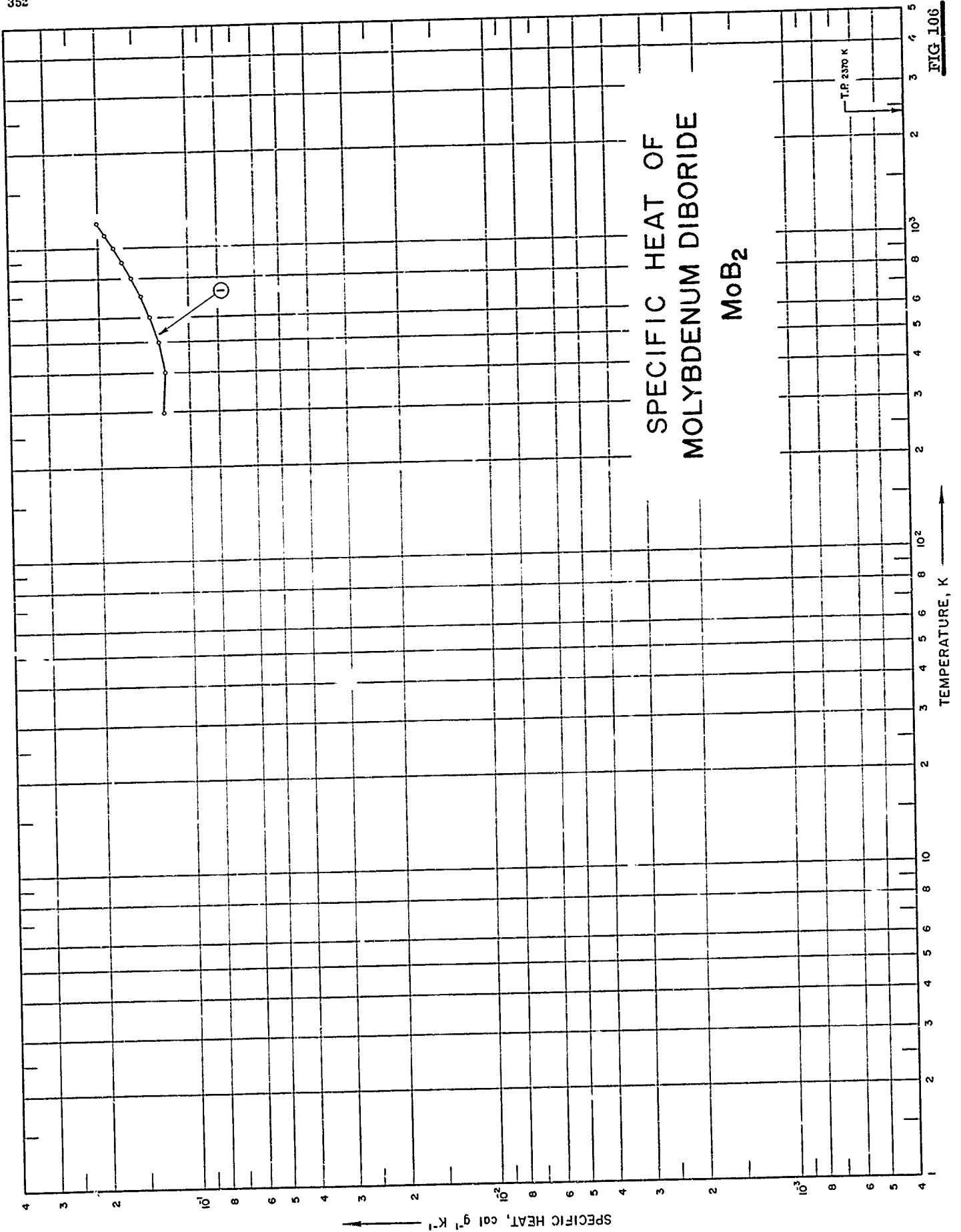

FIG 106

SPECIFICATION TABLE NO. 106 SPECIFIC HEAT OF MOLYBDENUM DIBORIDE MoB₂

[For Data Reported in Figure and Table No. 106]

Curve No.	Ref. No.	Year	Temp. Range, K	Reported Error, %	Name and Specimen Designation	Composition (weight percent), Specifications and Remarks
1	163	1962	298-1200	0.5		Traces of impurities.

DATA TABLE NO. 106 SPECIFIC HEAT OF MOLYBDENUM DIBORIDE MoB_2 [Temperature, T, K; Specific Heat, C_p , Cal $\text{g}^{-1} \text{K}^{-1}$]

T	C_p
	<u>CURVE 1</u>
298.16	1.229 x 10^{-1}
300	1.231
400	1.211
500	1.266
600	1.350
700	1.448
800	1.553
900	1.664
1000	1.776
1100	1.890
1200	2.006

* Not shown on plot

FIG 107

SPECIFIC HEAT OF DIMOLYBDENUM BORIDE Mo_2B

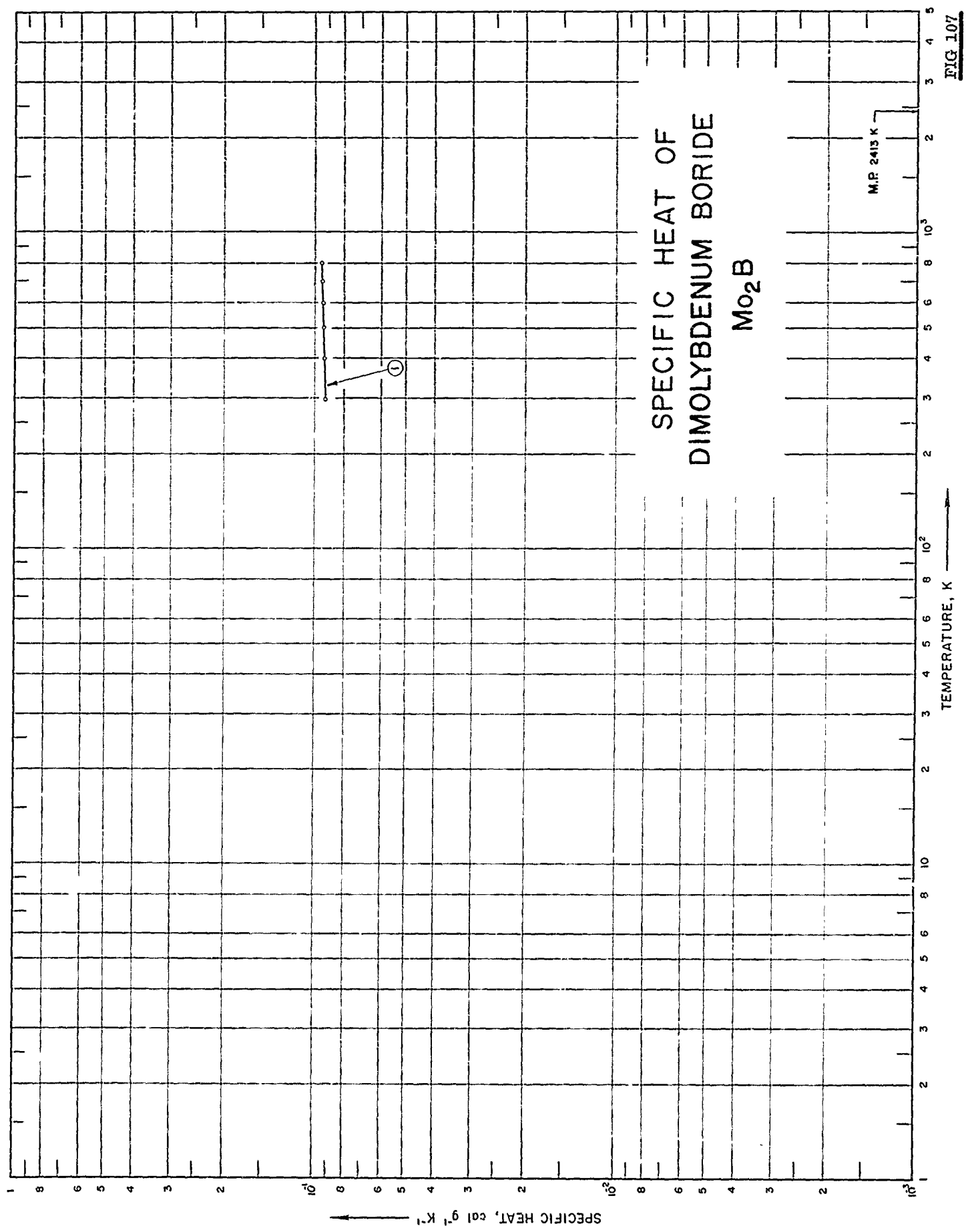

SPECIFICATION TABLE NO. 107 SPECIFIC HEAT OF DIMOLYBDENUM BORIDE Mo₂B

[For Data Reported in Figure and Table No. 107]

Curve No.	Ref. No.	Year	Temp. Range, K	Reported Error, %	Name and Specimen Designation	Composition (weight percent), Specifications and Remarks
1	163	1962	298-800	0.5		Traces of impurities.

DATA TABLE NO. 107 SPECIFIC HEAT OF DIMOLYBDENUM BORIDE Mo_2B [Temperature, T, K; Specific Heat, C_p , Cal $\text{g}^{-1} \text{K}^{-1}$]

T	C_p
<u>CURVE 1</u>	
298.16	9.270×10^{-2}
300	9.280
400	9.334
500	9.408
600	9.468
700	9.532
800	9.596

* Not shown on plot

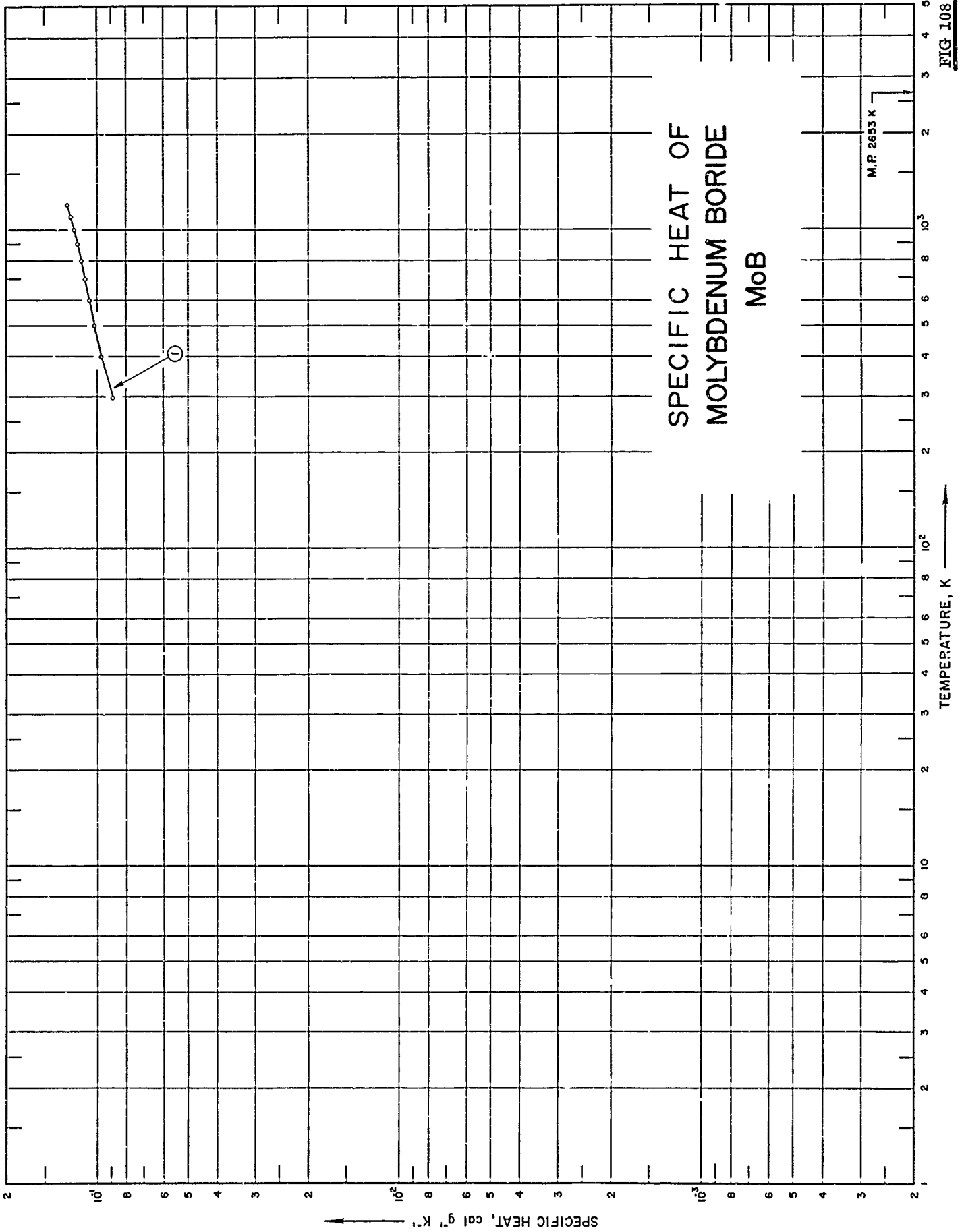

FIG 108

SPECIFICATION TABLE NO. 108 SPECIFIC HEAT OF MOLYBDENUM BORIDE MoB

[For Data Reported in Figure and Table No. 108]

Curve No.	Ref. No.	Year	Temp. Range, K	Reported Error, %	Name and Specimen Designation	Composition (weight percent), Specifications and Remarks
1	163	1962	298-1200	0.50		Traces of impurities.

DATA TABLE NO. 108 SPECIFIC HEAT OF MOLYBDENUM BORIDE MoB

[Temperature, T, K; Specific Heat, C_p , Cal $g^{-1} K^{-1}$]

T	C_p
	<u>CURVE 1</u>
298.16	8.824×10^{-2}
300	8.843*
400	9.649
500	1.017×10^{-1}
600	1.059
700	1.095
800	1.129
900	1.162
1000	1.192
1100	1.222
1200	1.252

* Not shown on plot

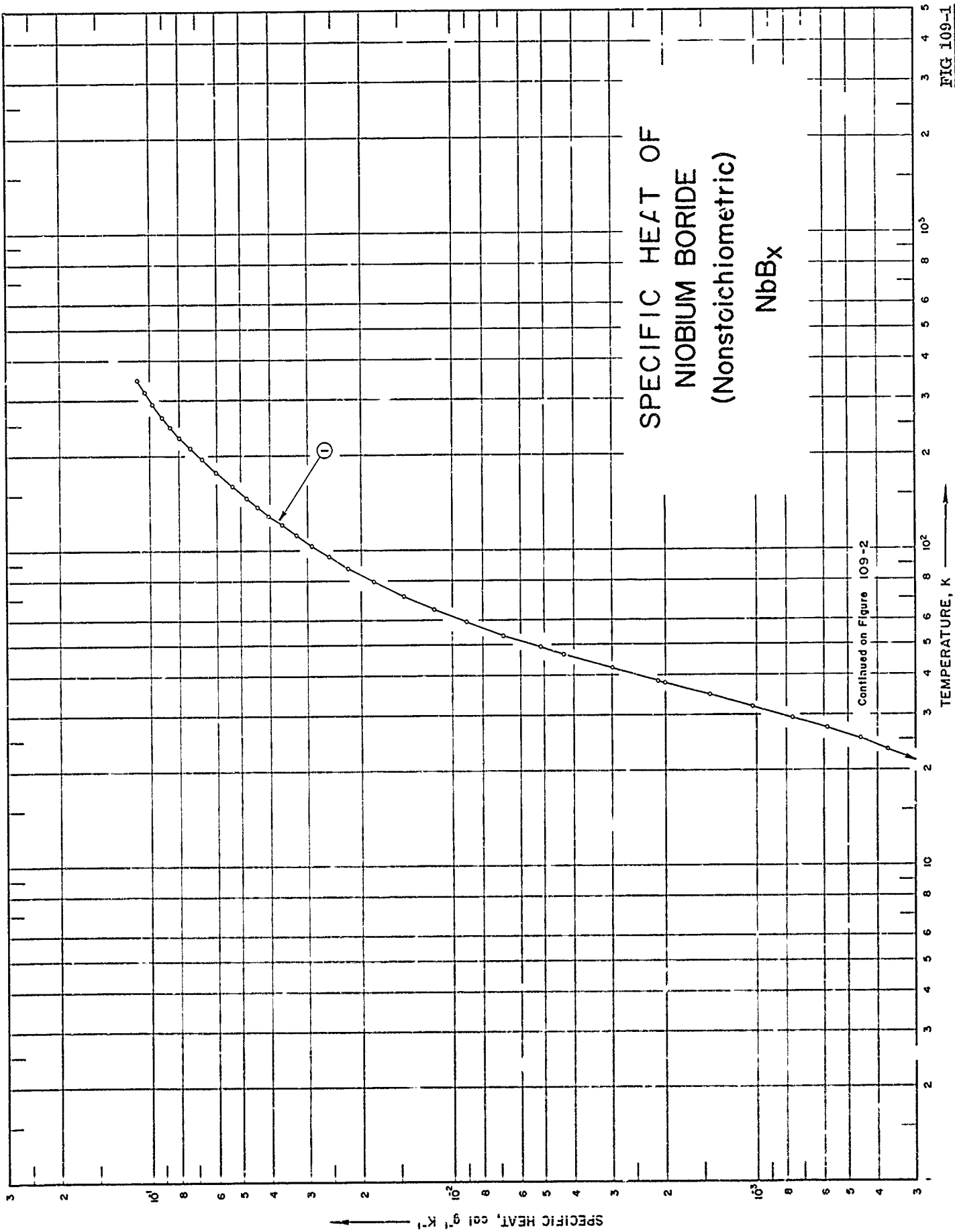

FIG 109-1

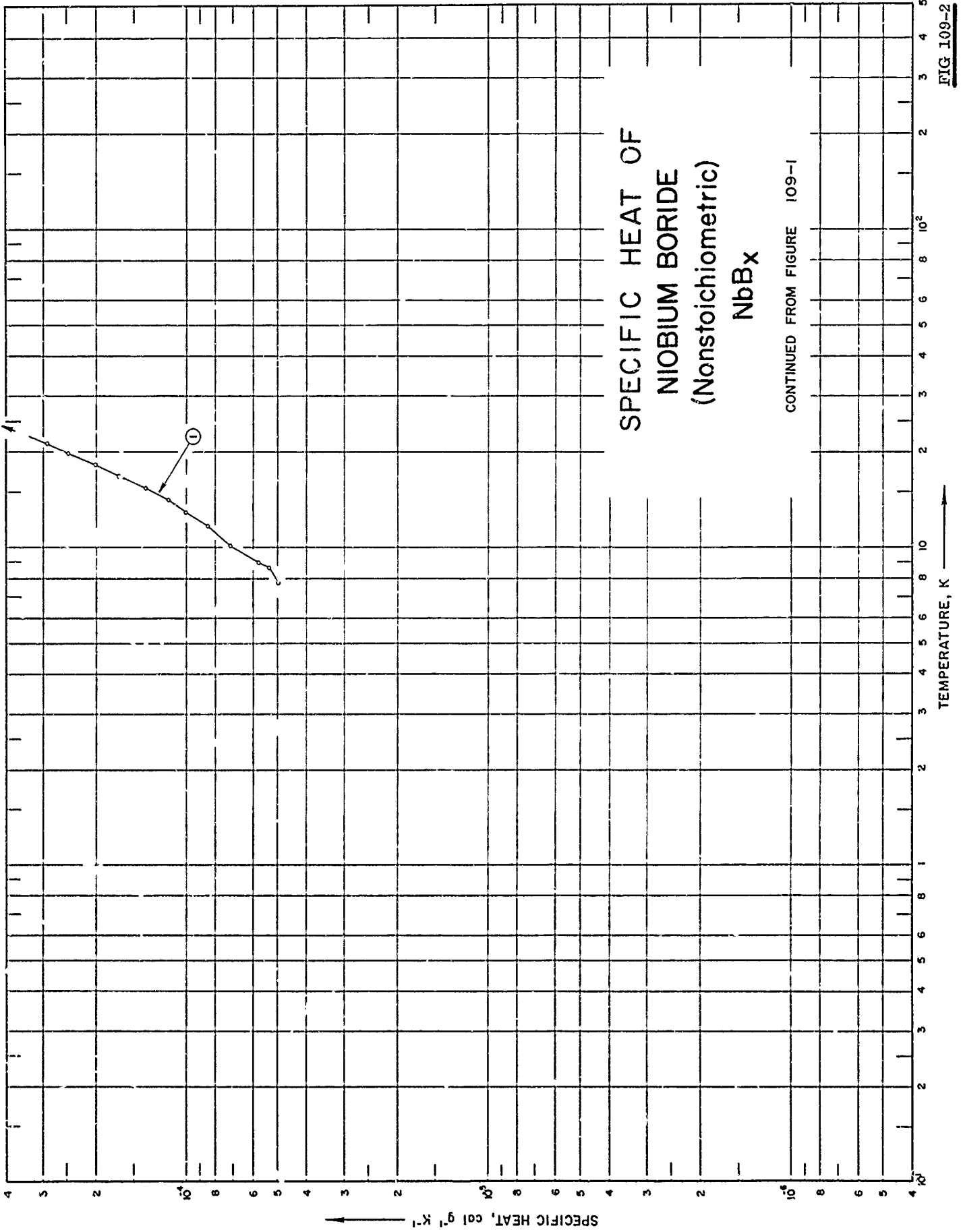

FIG 109-2

SPECIFICATION TABLE NO. 109 SPECIFIC HEAT OF NIOBIUM BORIDE (Nonstoichiometric) NbB_x

[For Data Reported in Figure and Table No. 109]

Curve No.	Ref. No.	Year	Temp. Range, K	Reported Error, %	Name and Specimen Designation	Composition (weight percent), Specifications and Remarks
1	168	1963	8-346	0.1-5	NbB _{1.53}	~99.868, impurities, 0.13 Ti, 0.001 Fe, 0.001 Si, 0.0142 C, 0.0066 O, and 0.0055 N; zone melted.

DATA TABLE NO. 109 SPECIFIC HEAT OF NIOBIUM BORIDE (Nonstoichiometric) NbB_x[Temperature, T, K; Specific Heat, C_p, Cal g⁻¹ K⁻¹]

T	C _p	T	C _p
<u>CURVE 1</u>		<u>CURVE 1 (cont.)</u>	
Series 1			
7.74	4.994 x 10 ⁻⁵	138.05	4.418
8.94	5.783	147.04	4.802
Series 2			
9.34	5.345 x 10 ⁻⁵	151.78	5.007*
10.09	7.185	160.23	5.363*
11.74	8.499	169.10	5.730*
12.96	1.008 x 10 ⁻⁴	178.07	6.093
14.14	1.157	186.83	6.437*
15.46	1.376	195.44	6.770
16.85	1.691	203.03	7.060*
18.28	2.006	211.65	7.380
19.76	2.488	220.48	7.694*
21.39	2.935	229.49	8.005
23.19	3.680	238.23	8.297*
25.05	4.539	247.12	8.583
27.04	5.835	256.05	8.852*
29.25	7.605	265.06	9.118
31.85	1.030 x 10 ⁻³	273.19	9.348*
34.75	1.434	282.10	9.593*
37.92	1.999	290.82	9.823
Series 3			
38.46	2.110 x 10 ⁻³	299.72	1.005 x 10 ⁻¹ *
42.23	2.989	309.17	1.028*
46.81	4.314	318.83	1.050
49.22	5.115	328.42	1.071*
53.94	6.839	337.71	1.090*
59.15	8.972	346.05	1.107*
64.98	1.155 x 10 ⁻²	Series 4	
71.67	1.455	313.40	1.037*
79.63	1.824	322.59	1.057*
87.98	2.217	331.91	1.078*
95.92	2.566	341.21	1.097*
104.09	2.926	347.74	1.109
112.42	3.294		
120.72	3.660		
129.29	4.037		

* Not shown on plot

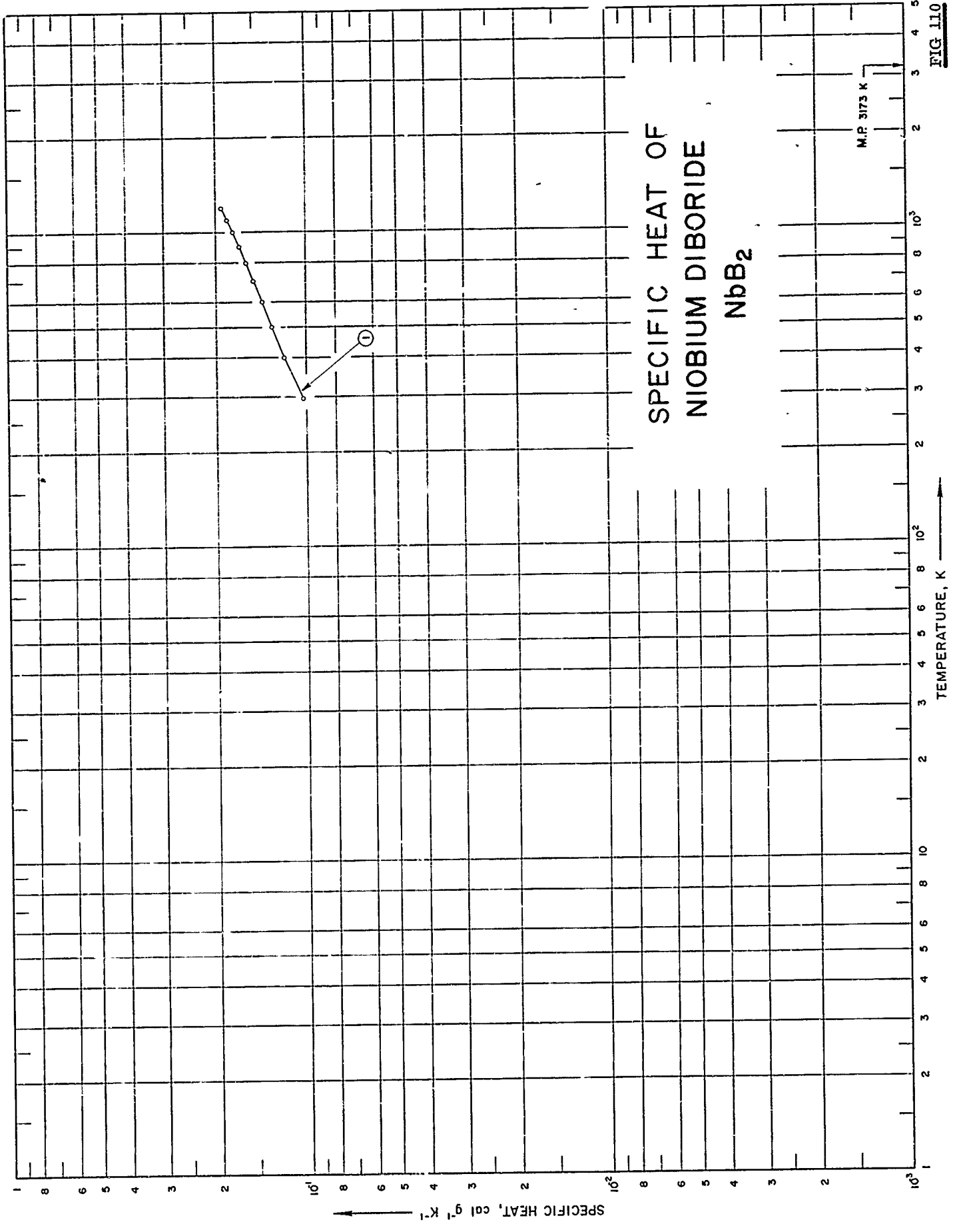

FIG 110

SPECIFICATION TABLE NO. 110 SPECIFIC HEAT OF NIOBIUM DIBORIDE NbB_2

[For Data Reported in Figure and Table No. 110]

Curve No.	Ref. No.	Year	Temp. Range, K	Reported Error, %	Name and Specimen Designation	Composition (weight percent), Specifications and Remarks
1	163	1962	298-1200	0.5		Traces of impurities.

DATA TABLE NO. 110 SPECIFIC HEAT OF NIOBIUM DIBORIDE NbB_2 [Temperature, T, K; Specific Heat, C_p , Cal $\text{g}^{-1} \text{K}^{-1}$]

T	C_p
<u>CURVE 1</u>	
298.16	1.031×10^{-1}
300	1.035*
400	1.192
500	1.309
600	1.409
700	1.503
800	1.592
900	1.679
1000	1.765
1100	1.848
1200	1.933

* Not shown on plot

SPECIFIC HEAT OF TANTALUM DIBORIDE TaB_2

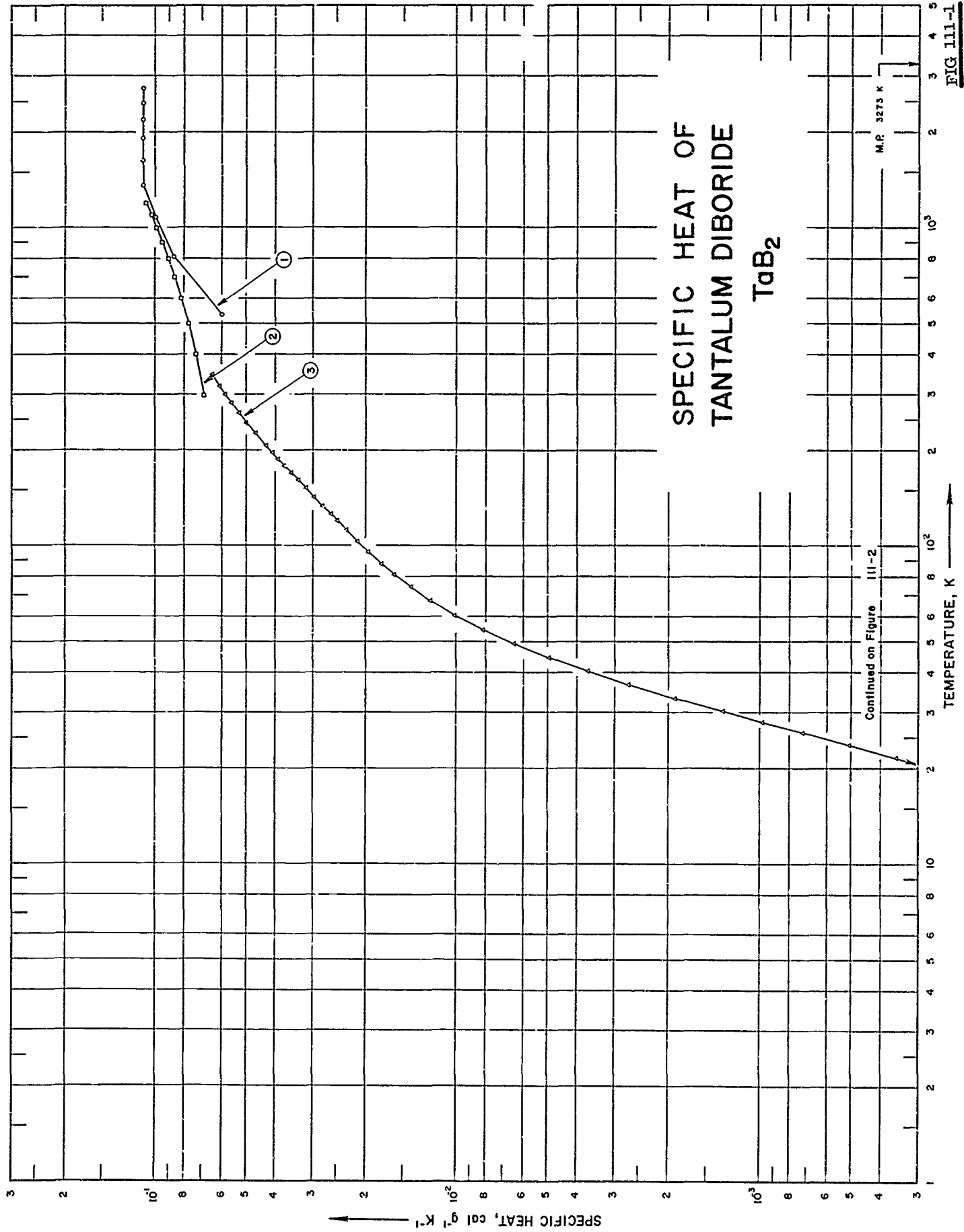

FIG III-1

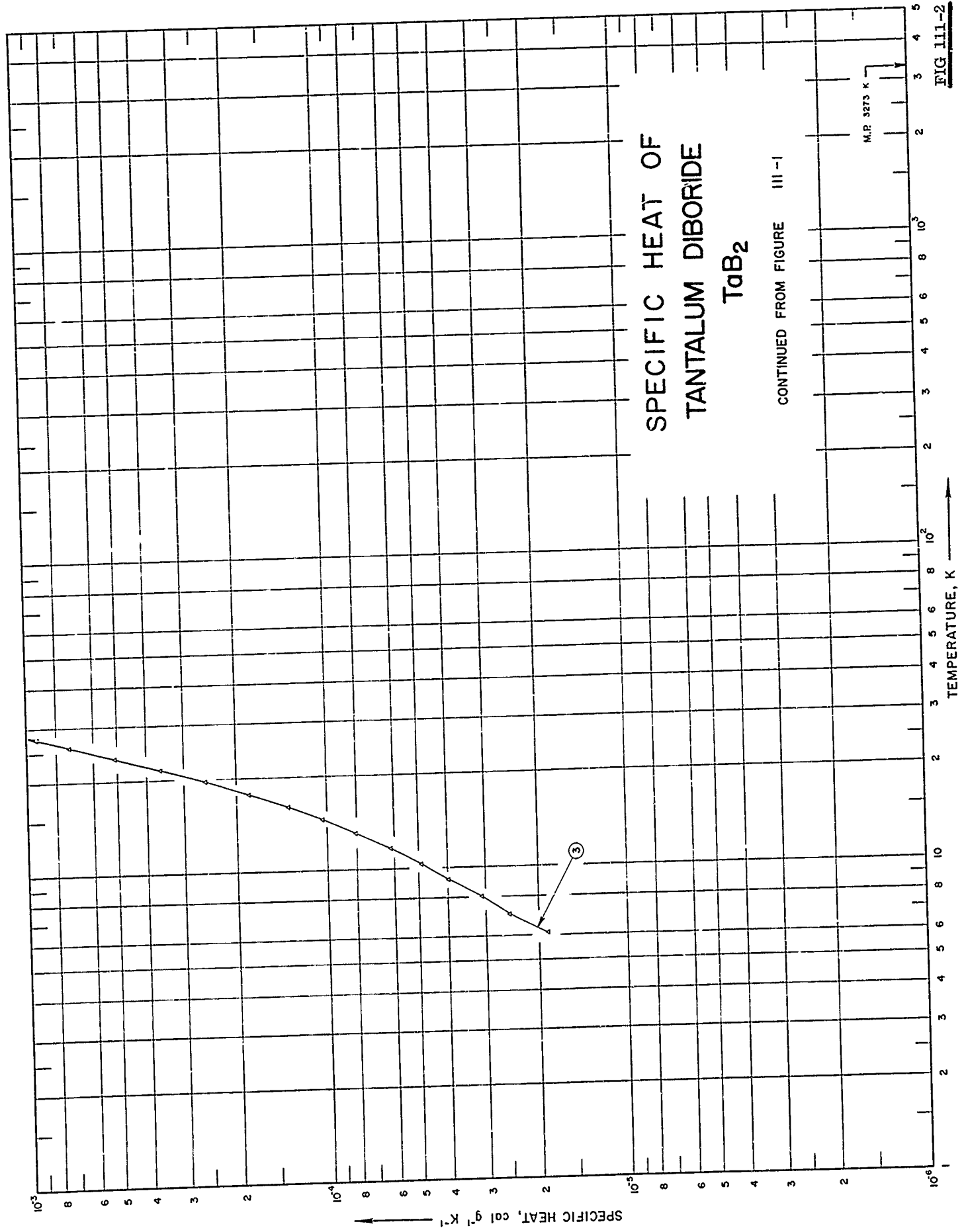

FIG III-2

SPECIFICATION TABLE NO. 111 SPECIFIC HEAT OF TANTALUM DIBORIDE TaB₂

[For Data Reported in Figure and Table No. 111]

Curve No.	Ref. No.	Year	Temp. Range, K	Reported Error, %	Name and Specimen Designation	Composition (weight percent), Specifications and Remarks
1	32	1962	533-2755	≤5		Sample supplied by General Electric Co; pressed and sintered; density 756 lb ft ⁻³ .
2	163	1962	298-1200	0.50		Traces of impurities.
3	169	1963	6-345		TaB ₂ , 11	88.80 Ta, 11.21 B, 0.001-0.01 Ti, Si, and Cr, 0.0200 C, 0.0029 O, 0.0022 N, polycrystalline, single phase; zone-refined.

DATA TABLE NO. 111 SPECIFIC HEAT OF TANTALUM DIBORIDE TaB₂[Temperature, T, K; Specific Heat, C_p, Cal g⁻¹ K⁻¹]

T	C _p	T	C _p	T	C _p
CURVE 1		CURVE 3 (cont.)		CURVE 3 (cont.)	
533.15	6.0 x 10 ⁻²	Series 1 (cont.)			
810.93	8.7	263.08	5.296 x 10 ⁻²	Series 2 (cont.)	
1088.71	1.0 x 10 ⁻¹	271.94	5.440*	104.24	2.126 x 10 ⁻²
1366.48	1.1	281.02	5.581	112.58	2.305
1644.26	1.1	290.40	5.720*	120.96	2.485
1922.04	1.1	299.73	5.852*		
2199.82	1.1	309.07	5.980*		
2477.59	1.1	318.35	6.101		
2755.37	1.1	327.49	6.220*		
		336.58	6.330*		
		345.64	6.431		
		Series 2			
298.16	6.901 x 10 ⁻²	6.10	1.865 x 10 ⁻⁵		
300	6.916*	7.01	2.503		
400	7.336	8.06	3.092		
500	7.780	9.15	3.975		
600	8.214	10.31	4.908		
700	8.644	11.67	6.184		
800	9.078	13.10	8.049		
900	9.513	14.54	1.040 x 10 ⁻⁴		
1000	9.942	16.08	1.355		
1100	1.038 x 10 ⁻¹	17.80	1.835		
1200	1.081	19.65	2.547		
		21.60	3.583		
		23.67	5.104		
		25.91	7.254		
		27.97	9.845		
		30.24	1.331 x 10 ⁻³		
		33.24	1.911		
		36.68	2.712		
		40.35	3.698		
		44.54	4.954		
		49.26	6.464		
		54.43	8.137		
		60.47	1.010 x 10 ⁻²		
		67.25	1.217		
		74.37	1.414		
		81.55	1.608		
		88.20	1.776		
		96.16	1.955		
		Series 3			
		Series 1			
126.62	2.604 x 10 ⁻²	126.62	2.604 x 10 ⁻²		
134.73	2.778	143.67	2.969		
143.67	2.969	152.53	3.158		
152.53	3.158	161.50	3.359		
161.50	3.359	170.52	3.537		
170.52	3.537	179.67	3.725		
179.67	3.725	188.71	3.912		
188.71	3.912	197.77	4.097		
197.77	4.097	207.30	4.287*		
207.30	4.287*	216.38	4.478*		
216.38	4.478*	226.38	4.658		
226.38	4.658	235.74	4.830*		
235.74	4.830*	245.06	5.001*		
245.06	5.001*	254.17	5.152*		
254.17	5.152*				

* Not shown on plot

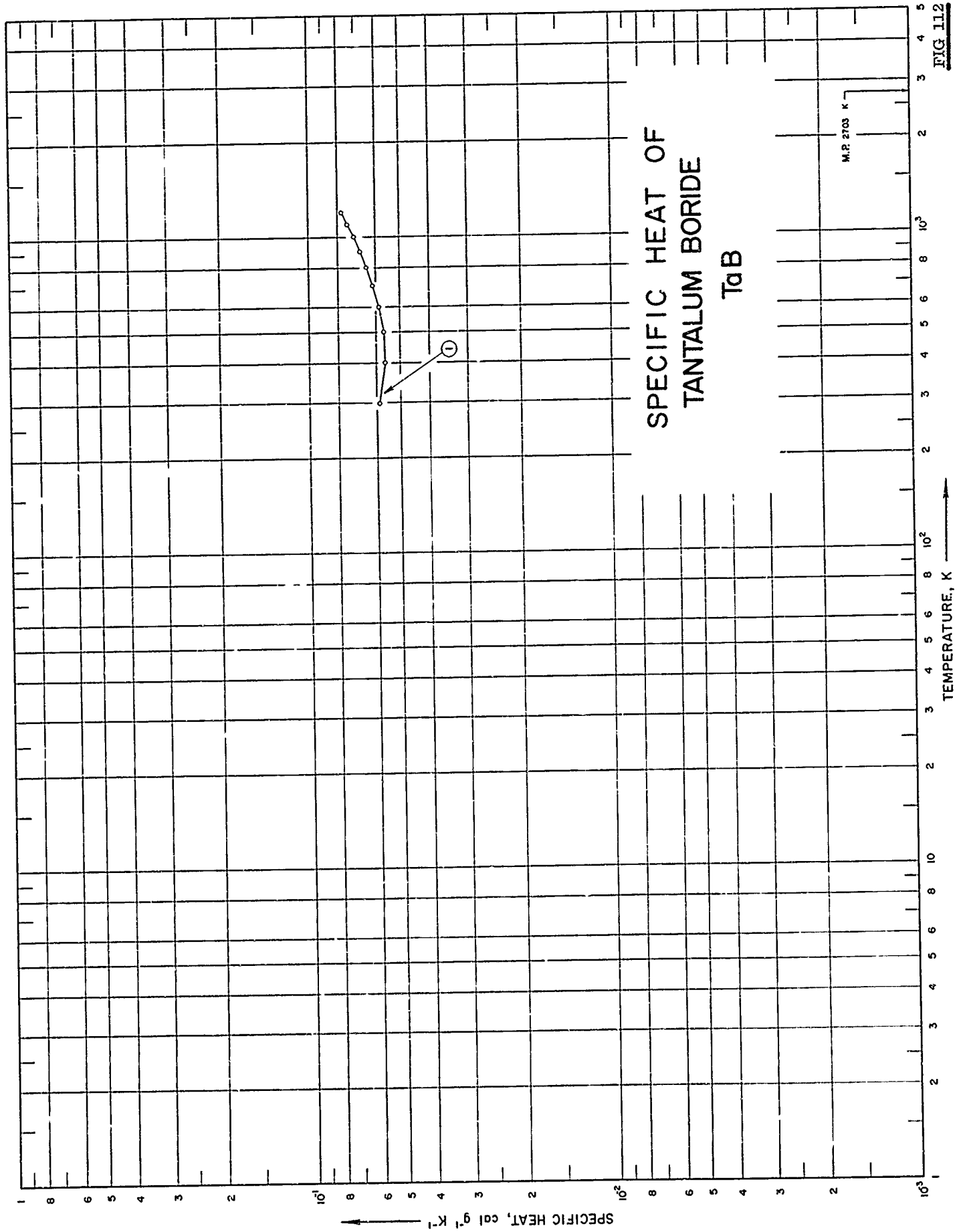

FIG. 11.2

SPECIFICATION TABLE NO. 112 SPECIFIC HEAT OF TANTALUM BORIDE Tab

[For Data Reported in Figure and Table No. 112]

Curve No.	Ref. No.	Year	Temp. Range, K	Reported Error, %	Name and Specimen Designation	Composition (weight percent), Specifications and Remarks
1	163	1962	298-1200	0.5		Traces of impurities.

DATA TABLE NO. 112 SPECIFIC HEAT OF TANTALUM BORIDE Tab

[Temperature, T, K; Specific Heat, C_p , Cal g⁻¹ K⁻¹]

T	C_p
	CURVE 1
298.16	5.893 x 10 ⁻²
300	5.898*
400	5.627
500	5.695
600	5.893
700	6.154
800	6.446
900	6.758
1000	7.081
1100	7.415
1200	7.755

* Not shown on plot

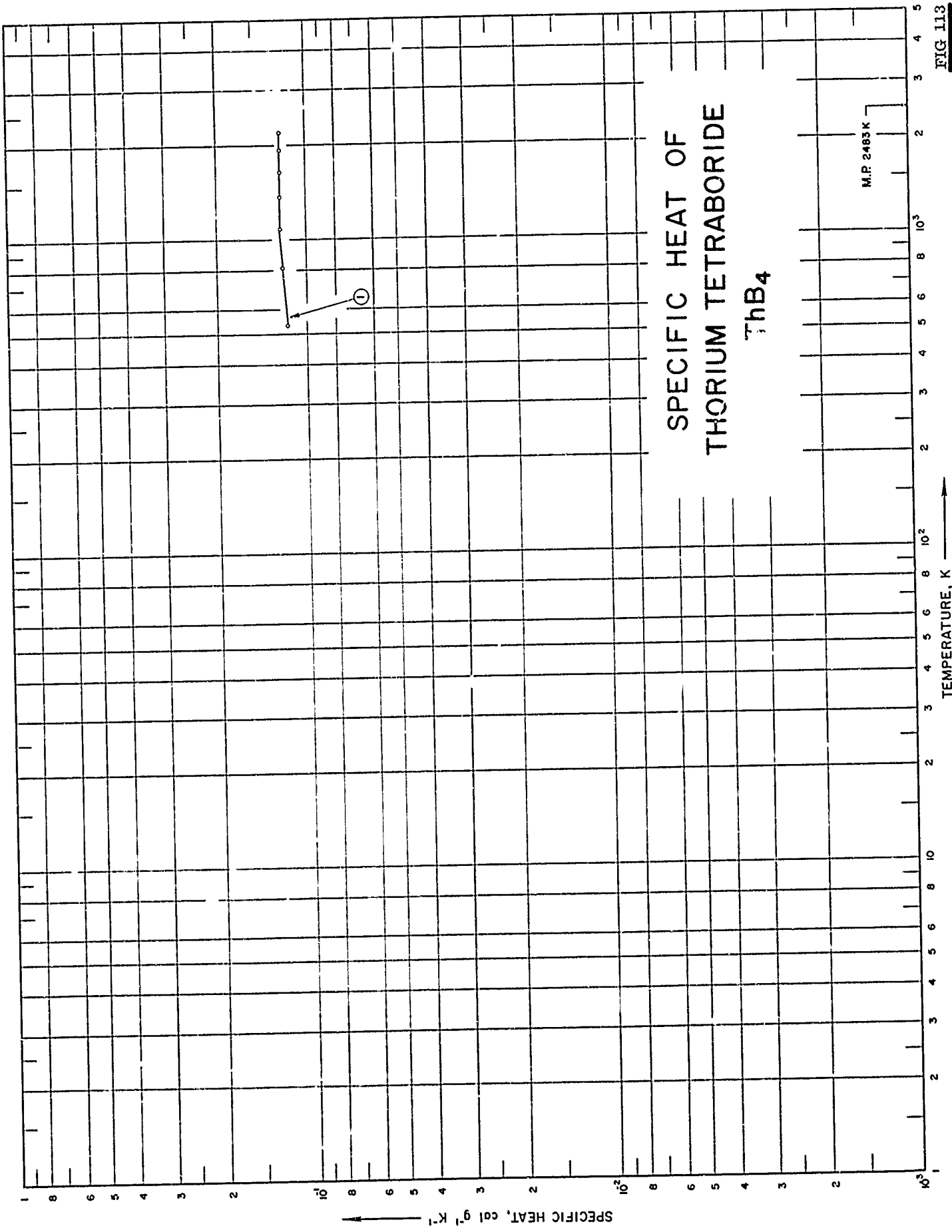

FIG. 113

SPECIFICATION TABLE NO. 113 SPECIFIC HEAT OF THORIUM TETRABORIDE ThB₄

[For Data Reported in Figure and Table No. 113]

Curve No.	Ref. No.	Year	Temp. Range, K	Reported Error, %	Name and Specimen Designation	Composition (weight percent), Specifications and Remarks
1	48	1962	533-2200	±5		Sample supplied by The Carborundum Co.; crushed in hardened steel mortar to pass 100-mesh screen; hot pressed; density at 25 C, before exposure; apparent density (ASTM method B311-58) 485 lb ft ⁻³ ; true density (by immersion in xylene) 510 lb ft ⁻³ .

DATA TABLE NO. 113 SPECIFIC HEAT OF THORIUM TETRABORIDE ThB₄
 [Temperature, T, K; Specific Heat, C_p, Cal g⁻¹ K⁻¹]

T	C _p
	<u>CURVE 1</u>
533.15	1.18 x 10 ¹
510.93	1.22
1088.71	1.24
1366.48	1.24
1644.26	1.24
1922.04	1.24
2199.82	1.24

Not shown on plot

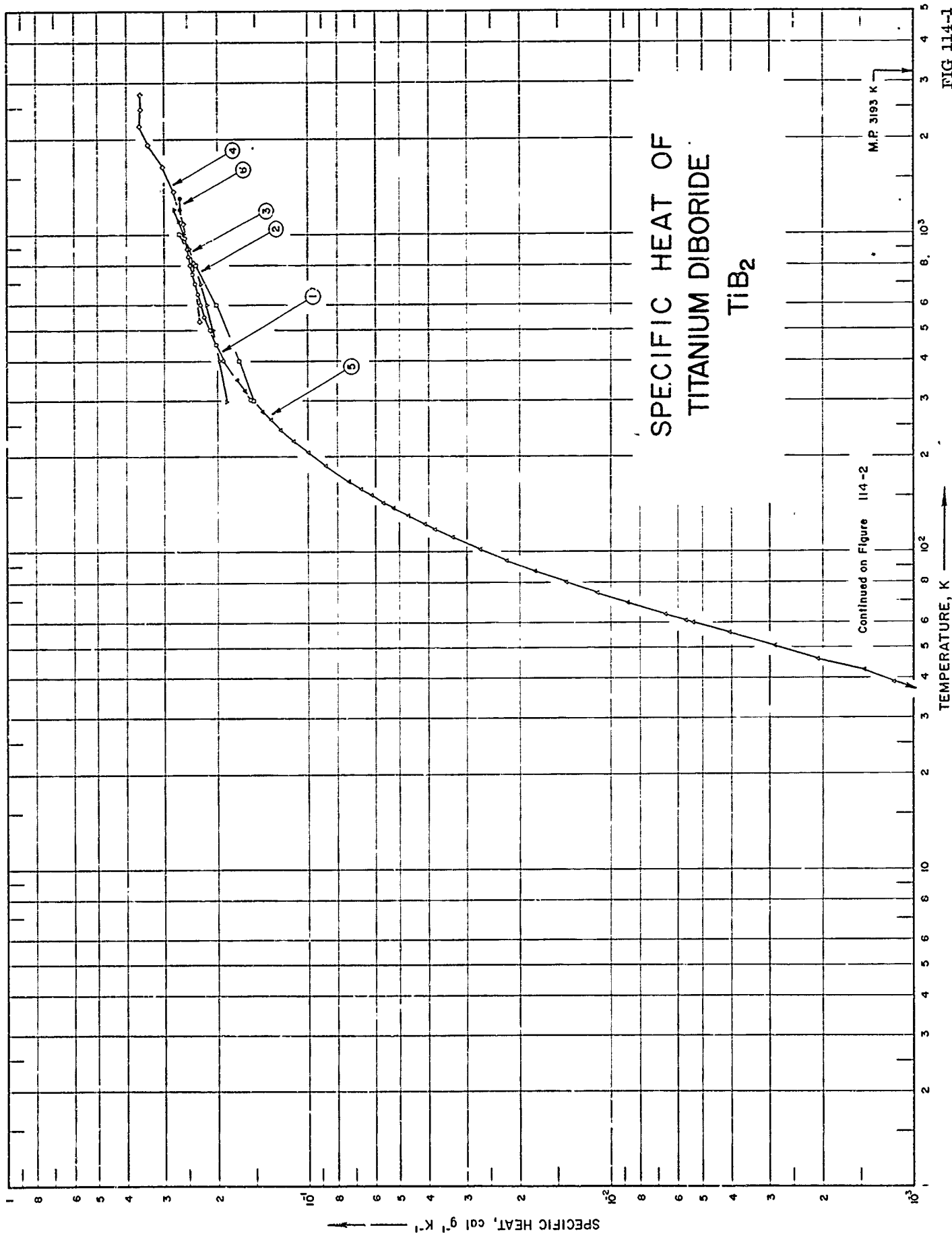
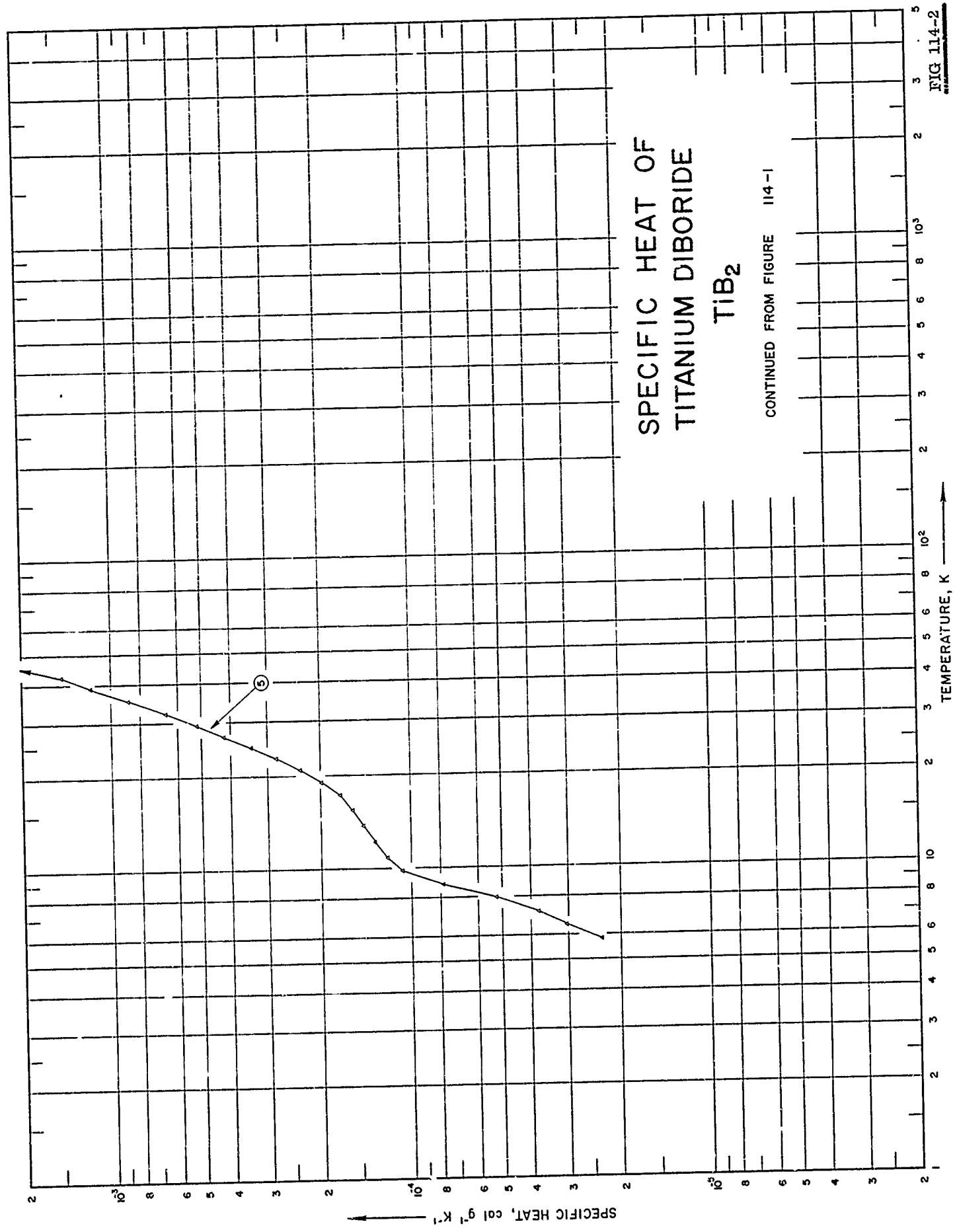

FIG 114-1



SPECIFICATION TABLE NO. 114 SPECIFIC HEAT OF TITANIUM DIBORIDE TiB_2

[For Data Reported in Figure and Table No. 114]

Curve No.	Ref. No.	Year	Temp. Range, K	Reported Error, %	Name and Specimen Designation	Composition (weight percent), Specifications and Remarks
1	310	1957	303-973			99.7 TiB_2 , 0.2 B, and 0.1 Fe.
2	171	1959	300-1000			Traces of impurities. Before exposure: 69.8 Ti, 29.5 B, 0.6 N ₂ , 0.4 Fe, 0.3 V, and 0.2 C, after exposure: 69.3 Ti, 28.7 B, 0.32 C, and 0.3 N ₂ ; sample supplied by The Carborundum Co; crushed in hardened steel mortar to pass 100-mesh screen; hot pressed; density at 25 C before exposure: apparent density (ASTM method B311-58) 281 lb ft ⁻³ , true density (by immersion in xylene) 285 lb ft ⁻³ , after exposure: apparent density 260 lb ft ⁻³ , true density 264 lb ft ⁻³ .
3	163	1962	298-1200			
4	48	1962	533-2755	≤5		
5	169	1963	6-347			
6	172	1964	273-1300			68.85 Ti, 30.48 B, 0.12 C, 0.11 O, 0.10 N, and 0.06 Fe, spectrographic analyses: 0.10 Co and Cr, 0.001 Ni and Si, 0.001-0.01 Mg, Al, and Mo, and 0.001 others; sample supplied by the Millmaster Chemical Co; zone-refined. 69.6 Ti, 28.0 B, and 0.97 C, monolithic titanium diboride; hot pressed; measured in an argon atmosphere.

DATA TABLE NO. 114 SPECIFIC HEAT OF TITANIUM DIBORIDE TiB_2 [Temperature, T, K; Specific Heat, C_p , Cal g $^{-1}$ K $^{-1}$]

<u>CURVE 1</u>		<u>CURVE 4 (cont.)</u>		<u>CURVE 5 (cont.)</u>		<u>CURVE 5 (cont.)</u>		<u>CURVE 5 (cont.)</u>	
T	C_p	T	C_p	T	C_p	T	C_p	T	C_p
303.15	1.556 x 10 $^{-1}$	2199.82	3.62 x 10 $^{-1}$	42.32	1.551 x 10 $^{-3}$	273.15	1.404 x 10 $^{-1}$ *		
400	1.910	2477.59	3.60	45.95	2.071	298.15	1.539		
450	2.033	2755.37	3.60	50.37	2.874	300	1.548*		
500	2.131			55.50	4.087	400	1.912*		
550	2.213	<u>CURVE 5</u>		60.74	5.673	500	2.131*		
600	2.280					600	2.276*		
650	2.337					700	2.381*		
700	2.386					800	2.460*		
750	2.428					900	2.523*		
800	2.465					1000	2.614*		
850	2.498					1100	2.641*		
900	2.527					1200	2.667		
973.15	2.564					1300	2.673		
<u>CURVE 2</u>						<u>CURVE 6</u>			
300	1.533 x 10 $^{-1}$								
400	1.698								
600	2.028								
800	2.357								
1000	2.688								
<u>CURVE 3</u>									
298.16	1.872 x 10 $^{-1}$								
300	1.877*								
400	1.979								
500	2.081								
600	2.183								
700	2.286*								
800	2.388*								
900	2.488								
1000	2.591								
1100	2.693								
1200	2.795								
<u>CURVE 4</u>									
533.15	2.30 x 10 $^{-1}$								
810.93	2.40								
1088.71	2.60								
1366.48	2.80								
1644.26	3.05								
1922.04	3.40								

* Not shown on plot

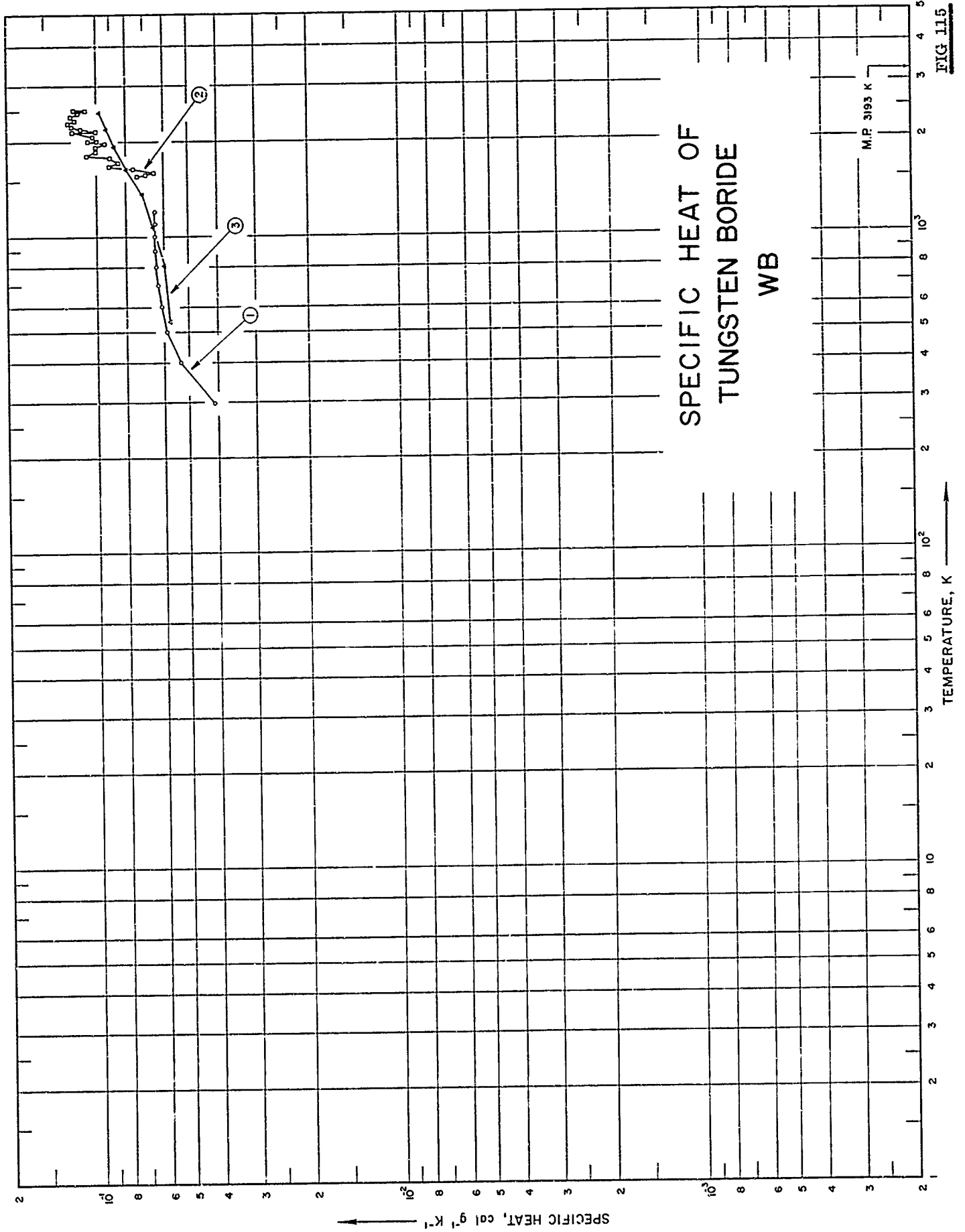

FIG 115

SPECIFICATION TABLE NO. 115 SPECIFIC HEAT OF TUNGSTEN BORIDE WB

[For Data Reported in Figure and Table No. 115]

Curve No.	Ref. No.	Year	Temp. Range, K	Reported Error, %	Name and Specimen Designation	Composition (weight percent), Specifications and Remarks
1	163	1962	298-1200	0.5		Traces of impurities.
2	173	1962	1556-2518	±5		93.7 W, 5.16 B, 0.16 O, 0.09 C, 0.01 N and ~0.88 impurities; hot pressed.
3	48	1962	533-2478	±5		Before exposure: 95.3 W, 4.7 B, 0.2 Nb, Fe, Si, and V, and 0.1 Zr, after exposure: 94.8 W, 5.2 B, 0.09 C; sample supplied by The Carborundum Co; crushed in hardened steel mortar to pass 100-mesh screen; hot pressed; density at 25 C, before exposure: apparent density (ASTM B311-58) 950 lb ft ⁻³ , true density (by immersion in xylene) 955 lb ft ⁻³ , after exposure: apparent density 918 lb ft ⁻³ , true density 924 lb ft ⁻³ .

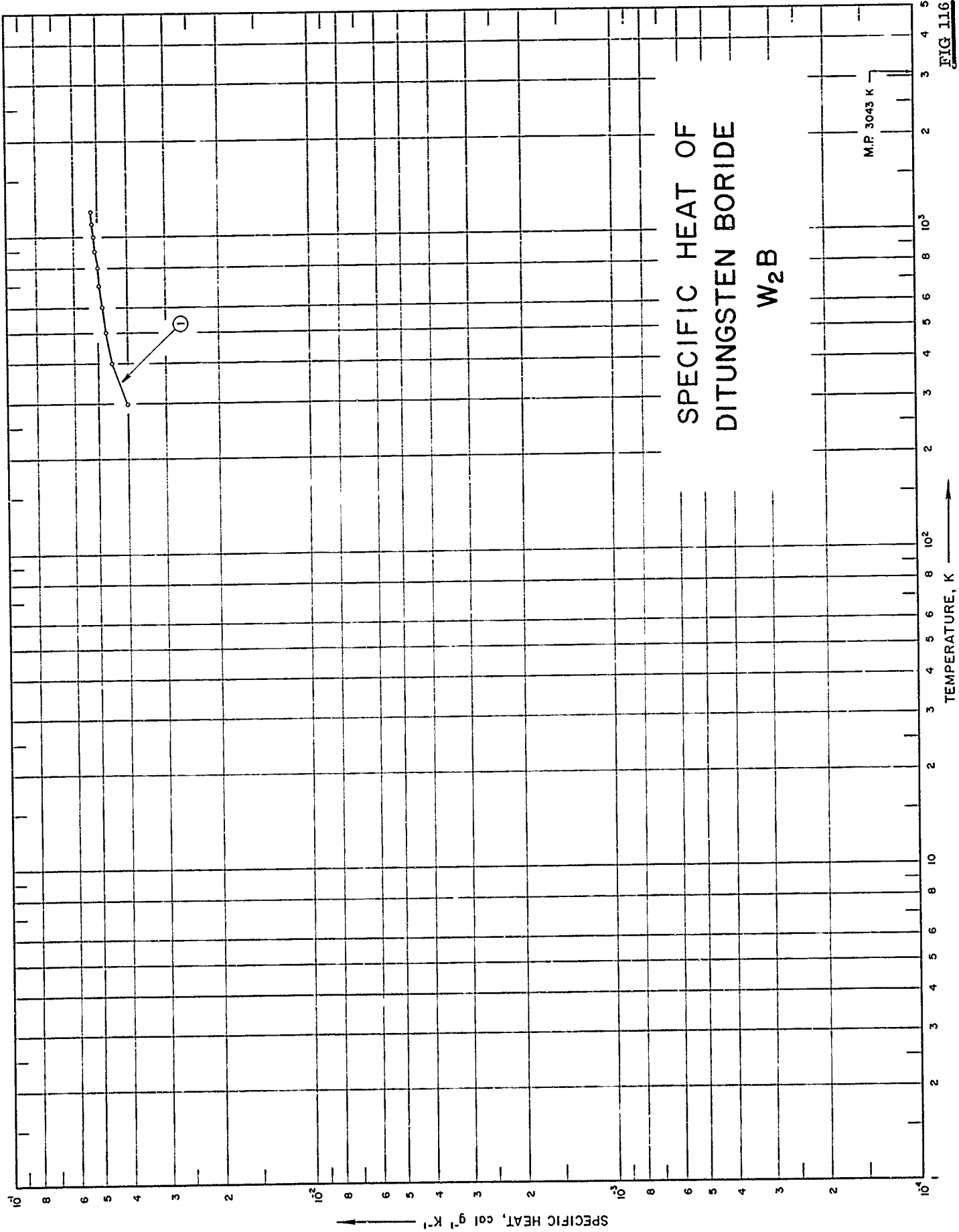

FIG 116

SPECIFICATION TABLE NO. 116 SPECIFIC HEAT OF DITUNGSTEN BORIDE W₂B

[For Data Reported in Figure and Table No. 116]

Curve No.	Ref. No.	Year	Temp. Range, K	Reported Error, %	Name and Specimen Designation	Composition (weight percent), Specifications and Remarks
1	163	1962	298-1200	0.5		Traces of impurities.

DATA TABLE NO. 116 SPECIFIC HEAT OF DITUNGSTEN BORIDE W_2B [Temperature, T, K; Specific Heat, C_p , Cal $g^{-1} K^{-1}$]

T	C_p
<u>CURVE 1</u>	
298.16	4.058×10^2
300	4.071*
400	4.512
500	4.737
600	4.874
700	4.975
800	5.051
900	5.117
1000	5.176
1100	5.228
1200	5.279

* Not shown on plot

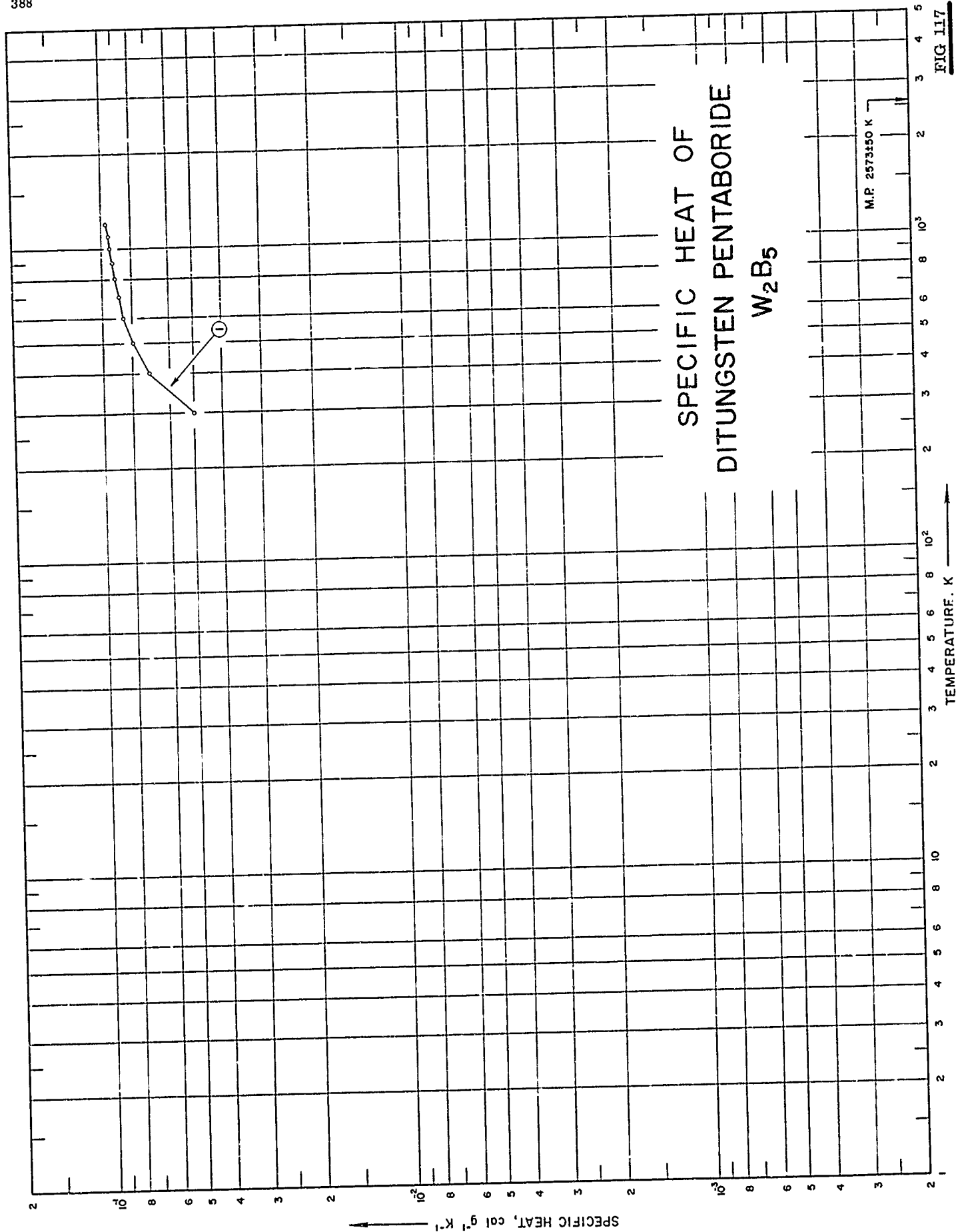

FIG 117

SPECIFICATION TABLE NO. 117 SPECIFIC HEAT OF DITUNGSTEN PENTABORIDE W_2B_5

[For Data Reported in Figure and Table No. 117]

Curve No.	Ref. No.	Year	Temp. Range, K	Reported Error, %	Name and Specimen Designation	Composition (weight percent), Specifications and Remarks
1	163	1962	298-1200	0.50		Traces of impurities.

DATA TABLE NO. 117 SPECIFIC HEAT OF DITUNGSTEN PENTABORIDE W_2P_5 [Temperature, T, K; Specific Heat, C_p , Cal $g^{-1} K^{-1}$]

T	C_p
CURVE 1	
298.16	5.001×10^{-2}
300	5.055
400	7.030
500	7.971
600	8.505
700	8.846
800	9.065
900	9.266
1000	9.408
1100	9.527
1200	9.629

* Not shown on plot

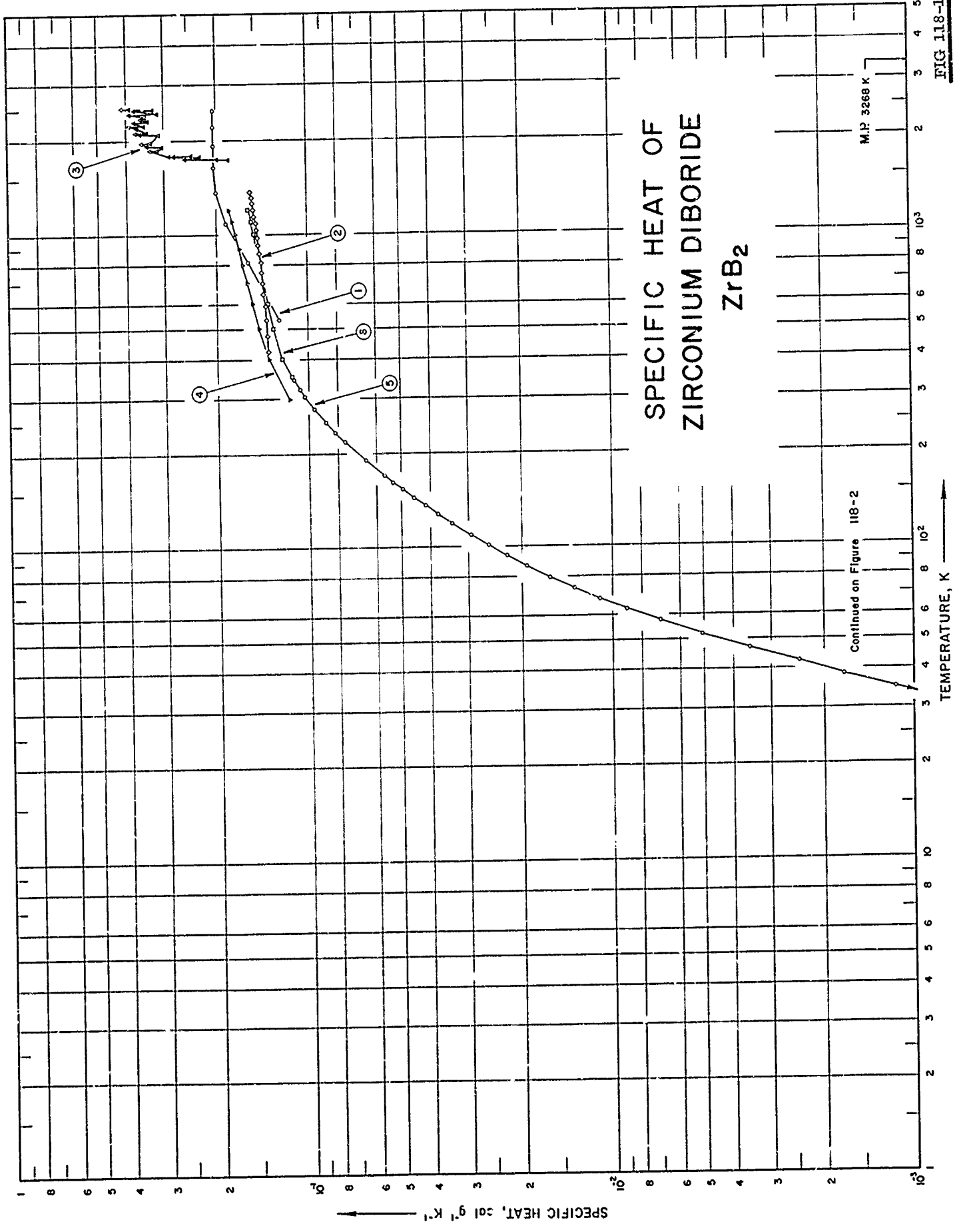

FIG 118-1

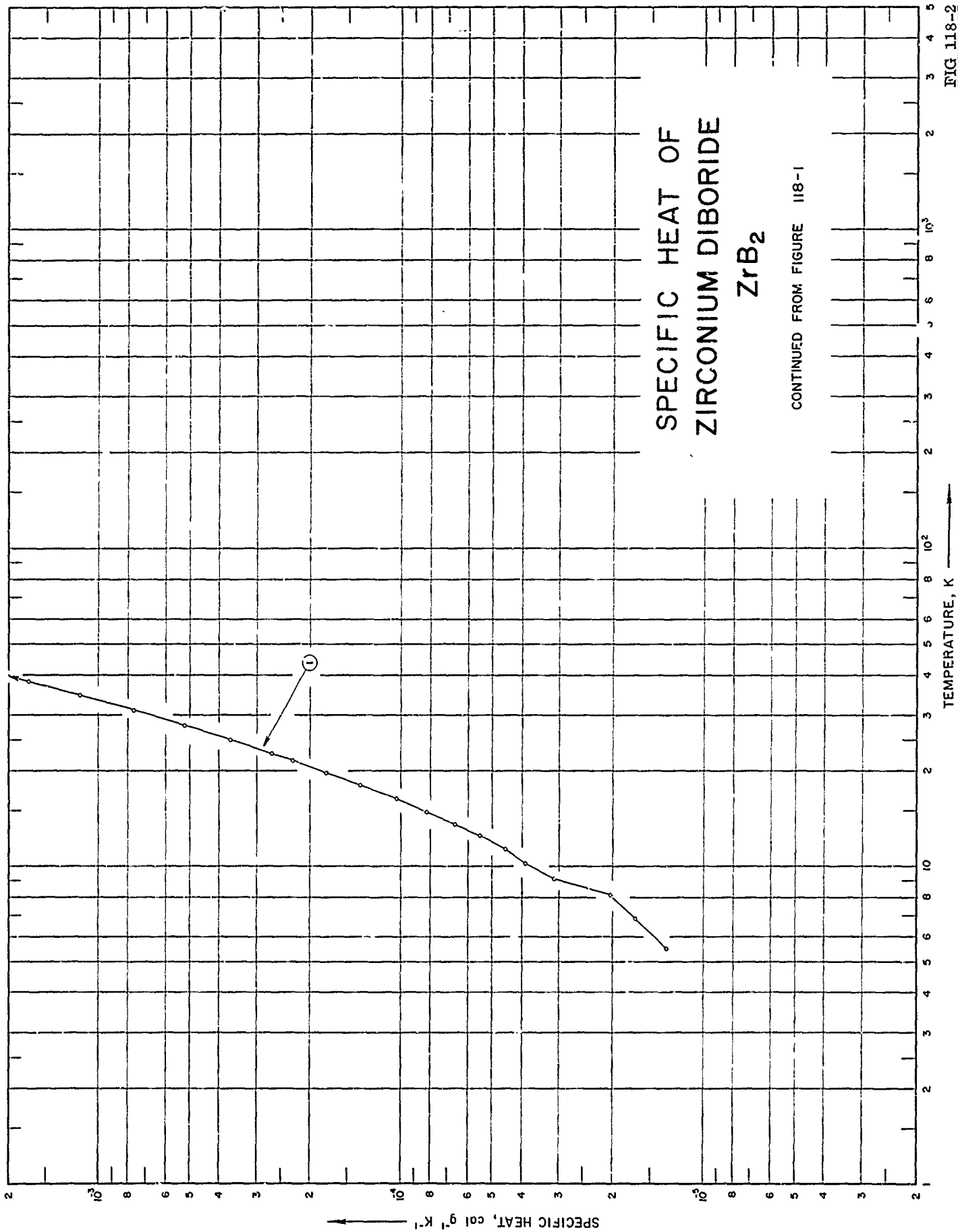

FIG 118-2

SPECIFICATION TABLE NO. 118 SPECIFIC HEAT OF ZIRCONIUM DIBORIDE ZrB_2

[For Data Reported in Figure and Table No. 118]

Curve No.	Ref. No.	Year	Temp. Range, K	Reported Error, %	Name and Specimen Designation	Composition (weight per cent), Specifications and Remarks
1	32	1962	533-2478	±5		78.7 Zr, 17.6 B, 0.36 C, remainder Al, Ca, Fe, Ni, Si, and Ti; sample supplied by Norton Co; hot pressed; density 258 lb ft ⁻³ .
2	76	1961	422-1366	5		Major constituent ZrB_2 , 1.60 O ₂ , 1.4 N ₂ ; sample made by spraying powder HfC using powder gun with 80 ft ³ hr ⁻¹ N ₂ - plasma gas and 10 ft ³ hr ⁻¹ N ₂ -carrier gas.
3	173	1962	1739-2521	±5		78.94 Zr, 16.86 B, 1.36 O, <0.5 Ni, 0.37 total C, <0.3 Al, <0.25 Hf, <0.02 V, 0.18 Fe, 0.14 N, 0.14 Ti, 0.1 Cr, <0.05 Cu, <0.01 Mg, Mn, and Nb.
4	163	1962	298-1200	0.5		Traces of impurities.
5	164	1962	5-345	0.1-5		Sample A: 98.62 ZrB_2 , Sample B: 99.51 ZrB_2 ; spectrochemical analysis: Ag, Cu, Ti, V, Cr, and Mn, 0.0010, Al and Mg 0.0010 - 0.0100, Hf and Fe 0.0010 - 0.1000, and Si 0.0100 - 0.1000; zone-refined.
6	174	1964	400-1200			99.3 ZrB_2 , 0.01 - 0.1 Si, 0.001 - 0.1 Hf and Fe, 0.0215 C, 0.0134 N, 0.001 - 0.01 Mg, 0.0052 O, 0.001 Ag, Ca, Cu, Ti, V, Cr, and Mn; zone refined.

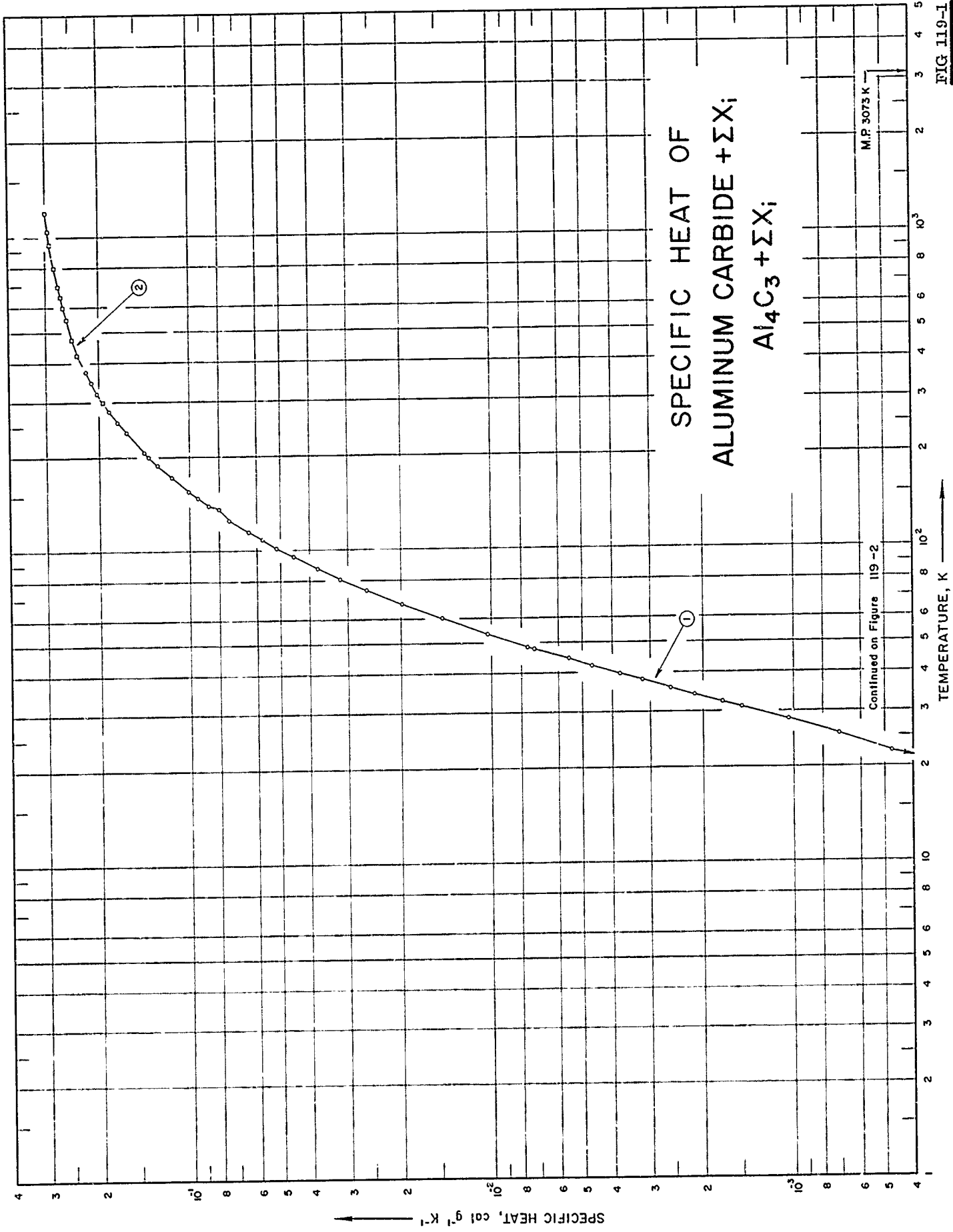

FIG 119-1

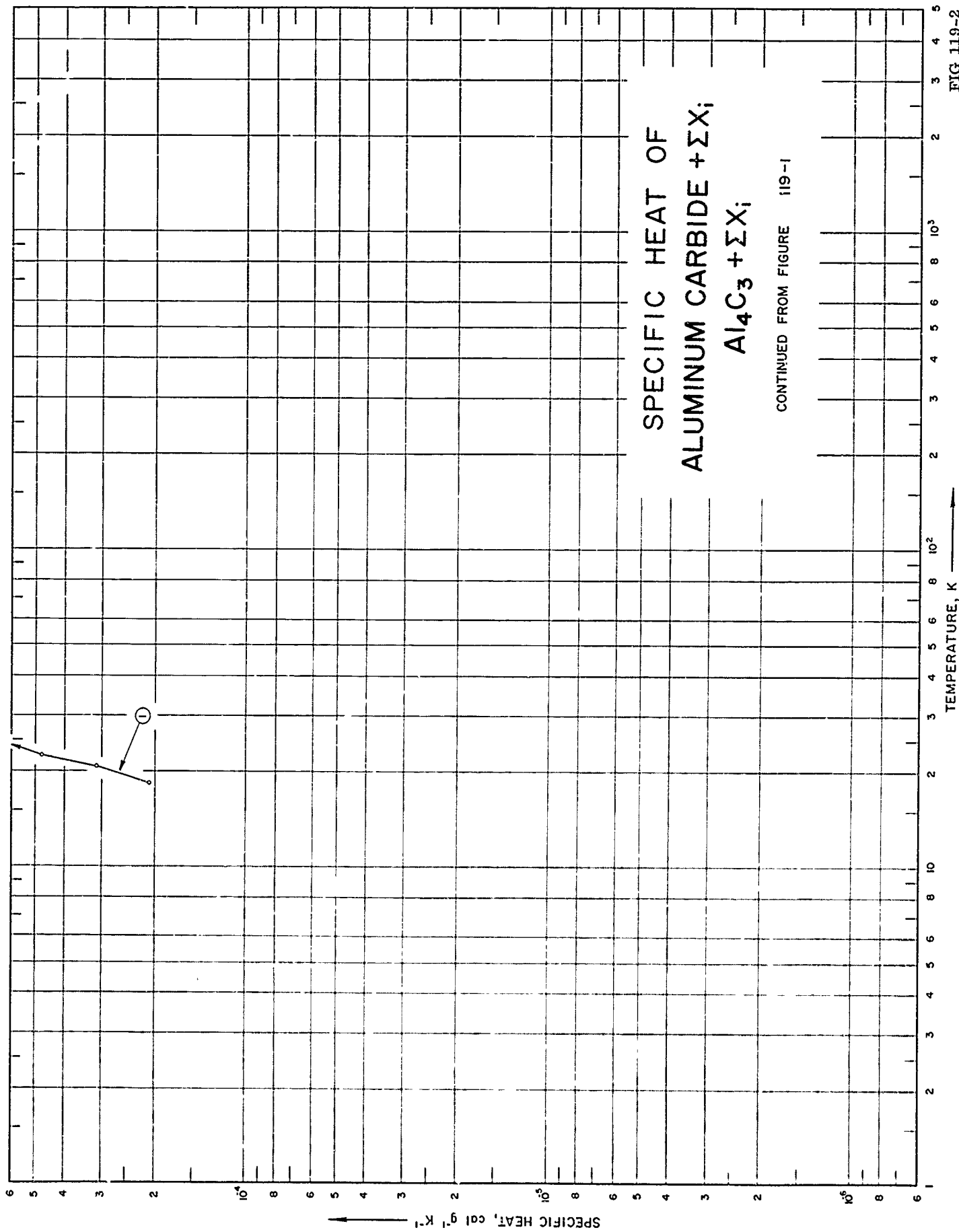

FIG 119-2

SPECIFICATION TABLE NO. 119 SPECIFIC HEAT OF ALUMINUM CARBIDE + EX₁ Al₄C₃ + EX₁

[For Data Reported in Figure and Table No. 119]

Curve No.	Ref. No.	Year	Temp. Range, K	Reported Error, %	Name and Specimen Designation	Composition (weight percent), Specifications and Remarks
1	170	1964	18-375			94.8 Al ₄ C ₃ ; 2.1 Al ₂ O ₃ ; 1.2 free Al; 0.8 free C; and 1.3 AlN; spectrochemical analysis: 0.10-1.0 Fe, 0.01-0.1 Si, 0.01-0.1 V, 0.001-0.01 Cr, 0.001-0.01 Cu, 0.001-0.01 Mg; 0.001-0.01 N, 0.001-0.01 Ti, 0.001-0.01 Zr, 0.0001-0.001 Ca, 0.0001-0.001 Mn.
2	170	1964	300-1200			Same as above.

DATA TABLE NO. 149 SPECIFIC HEAT OF ALUMINUM CARBIDE + ΣX_1 $Al_4C_3 + \Sigma X_1$
 [Temperature, T, K; Specific Heat, C_p , Cal g⁻¹ K⁻¹]

T	C_p	T	C_p	T	C_p	T	C_p	T	C_p
CURVE 1		CURVE 1 (cont.)		CURVE 1 (cont.)		CURVE 1 (cont.)		CURVE 2 (cont.)	
Series 1									
80.93	3.161 x 10 ⁻²	19.44	2.557 x 10 ⁻⁴	53.67	1.033 x 10 ⁻²	280.88	1.856 x 10 ⁻¹	475	2.462 x 10 ⁻¹
87.53	3.777	21.28	3.553	59.91	1.444	291.76	1.909	500	2.505*
95.52	4.507	23.19	4.947	67.04	1.984	303.40	1.962	600	2.643
102.19	5.174	26.12	7.770	73.82	2.534	318.92	2.013	700	2.697
109.19	5.795	28.95	1.146 x 10 ⁻³	80.93	3.169	326.34	2.060	750	2.782*
115.26	6.375	31.83	1.624	88.80	3.897	337.69	2.103	800	2.818
120.96	6.913	34.70	2.251	96.70	4.618	348.85	2.143	850	2.849*
126.36	7.421*	37.94	3.149	104.96	5.394			900	2.877*
				113.34	6.192			950	2.902*
Series 2									
83.37	3.394 x 10 ⁻² *								
83.78	3.433*								
92.00	4.186*								
99.30	4.858*								
105.92	5.486*								
112.10	6.073*								
118.39	6.671*								
125.29	7.322*								
137.59	8.005								
140.09	8.693								
148.27	9.429								
156.82	1.018 x 10 ⁻¹								
165.07	1.088*								
173.09	1.155								
181.15	1.219*								
189.92	1.287								
199.00	1.355*								
Series 3									
208.26	1.422 x 10 ⁻²								
194.84	1.324*								
204.78	1.397*								
214.36	1.464*								
223.62	1.526*								
232.60	1.584*								
241.34	1.638								
250.22	1.691*								
259.24	1.742								
Series 4									
83.37	3.394 x 10 ⁻² *								
83.78	3.433*								
92.00	4.186*								
99.30	4.858*								
105.92	5.486*								
112.10	6.073*								
118.39	6.671*								
125.29	7.322*								
137.59	8.005								
140.09	8.693								
148.27	9.429								
156.82	1.018 x 10 ⁻¹								
165.07	1.088*								
173.09	1.155								
181.15	1.219*								
189.92	1.287								
199.00	1.355*								
Series 5									
18.36	2.075 x 10 ⁻⁴								
20.59	3.221								
22.31	4.748								
25.39	7.056								
28.22	1.043 x 10 ⁻³								
31.07	1.494								
34.22	2.145								
38.06	3.196								
42.30	4.687								
Series 6									
32.27	1.722 x 10 ⁻³								
35.97	2.580								
39.90	3.790								
44.38	5.527								
48.77	7.601								
53.73	1.038 x 10 ⁻²								
60.19	1.467								
67.19	1.993								
Series 7									
47.95	7.195 x 10 ⁻³								
53.80	1.042 x 10 ⁻² *								
60.27	1.471*								
67.12	1.989*								
74.44	2.590								
82.58	3.321*								
Series 8*									
53.67	1.033 x 10 ⁻²								
59.91	1.444								
67.04	1.984								
73.82	2.534								
80.93	3.169								
88.80	3.897								
96.70	4.618								
104.96	5.394								
113.34	6.192								
Series 9									
202.70	1.382 x 10 ⁻¹ *								
212.73	1.453*								
222.81	1.521*								
233.19	1.587*								
244.99	1.660*								
257.76	1.773*								
270.12	1.801*								
282.14	1.862								
Series 10*									
228.26	1.556 x 10 ⁻¹								
238.86	1.623								
249.41	1.686								
260.04	1.746								
282.92	1.866								
Series 11									
287.59	1.888 x 10 ⁻¹ *								
299.20	1.943*								
310.67	1.994*								
322.19	2.042								
Series 12*									
280.88	1.856 x 10 ⁻¹								
291.76	1.909								
303.40	1.962								
318.92	2.013								
326.34	2.060								
337.69	2.103								
348.85	2.143								
Series 13*									
332.84	2.084 x 10 ⁻¹								
344.32	2.127								
355.74	2.167								
367.15	2.205								
Series 14									
332.39	2.082 x 10 ⁻¹ *								
338.24	2.104*								
349.39	2.145*								
354.70	2.165*								
365.61	2.202*								
376.38	2.235								
CURVE 2									
300	1.947 x 10 ⁻¹ *								
310	1.993*								
320	2.036*								
330	2.077*								
340	2.114*								
350	2.150*								
360	2.184*								
370	2.215*								
373.15	2.225*								
380	2.245*								
390	2.273*								
400	2.300*								
425	2.360								
450	2.414*								

* Not shown on plot

FIG 120

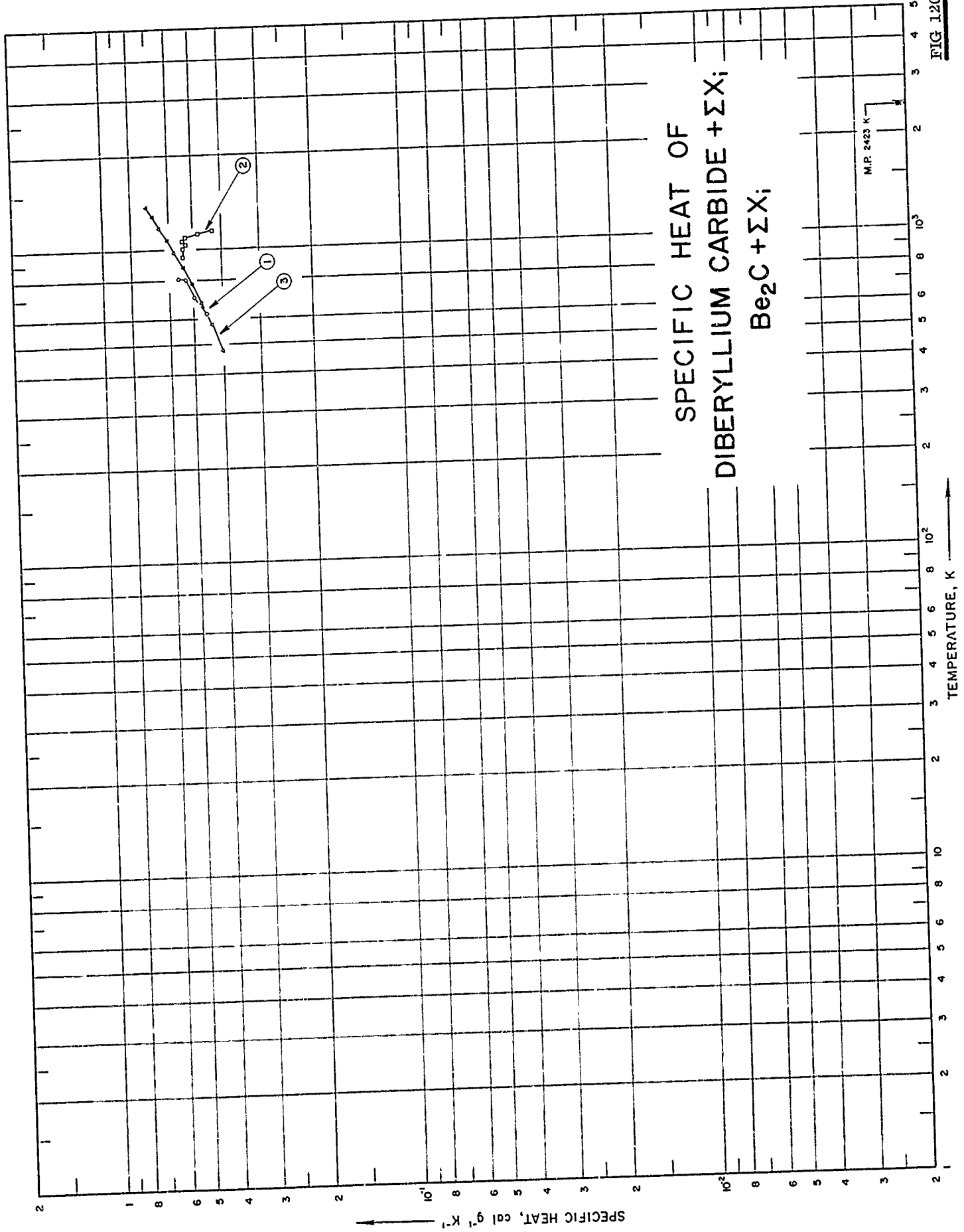

SPECIFICATION TABLE NO. 120 SPECIFIC HEAT OF DIBERYLLIUM CARBIDE + ΣX_i Be₂C + ΣX_i

[For Data Reported in Figure and Table No. 120]

Curve No.	Ref. No.	Year	Temp. Range, K	Reported Error, %	Name and Specimen Designation	Composition (weight percent), Specifications and Remarks
1	175	1948	625-804	± 15		56.5 Be, 3.14 free C and 0.005 free Fe, powdered sample.
2	176	1948	946-1150	± 25		Left end: 52.45 Be and 1.94 free C, middle: 48.65 Be and 3.39 free C, right end: 50.24 Be and 1.96 free C (theor. 60.05 Be); sample supplied by the Norton Co; hot pressed.
3	177	1950	473-1373	± 15		Before test: 80 Be ₂ C, most impurities were oxides and nitrides, after test: 74 Be ₂ C.

DATA TABLE NO. 120 SPECIFIC HEAT OF DIBERYLLIUM CARBIDE + ΣX_i Be₂C + ΣX_i
 [Temperature, T, K; Specific Heat, C_p, Cal g⁻¹ K⁻¹]

T	C _p
<u>CURVE 1</u>	
625.15	4.56 x 10 ⁻¹
622.15	4.46*
704.15	4.95
702.15	5.67*
699.65	5.40*
807.15	5.60
804.15	5.30
<u>CURVE 2</u>	
946.15	5.4 x 10 ⁻¹
970.15	5.4
1008.15	5.4
1042.15	5.3
1066.15	5.4
1091.15	5.3
1127.15	4.8
1150.15	4.3
<u>CURVE 3</u>	
473.15	4.04 x 10 ⁻¹
573.15	4.38
673.15	4.72
773.15	5.06
873.15	5.40
973.15	5.74
1073.15	6.08
1173.15	6.42
1273.15	6.76
1373.15	7.10

Not shown on plot

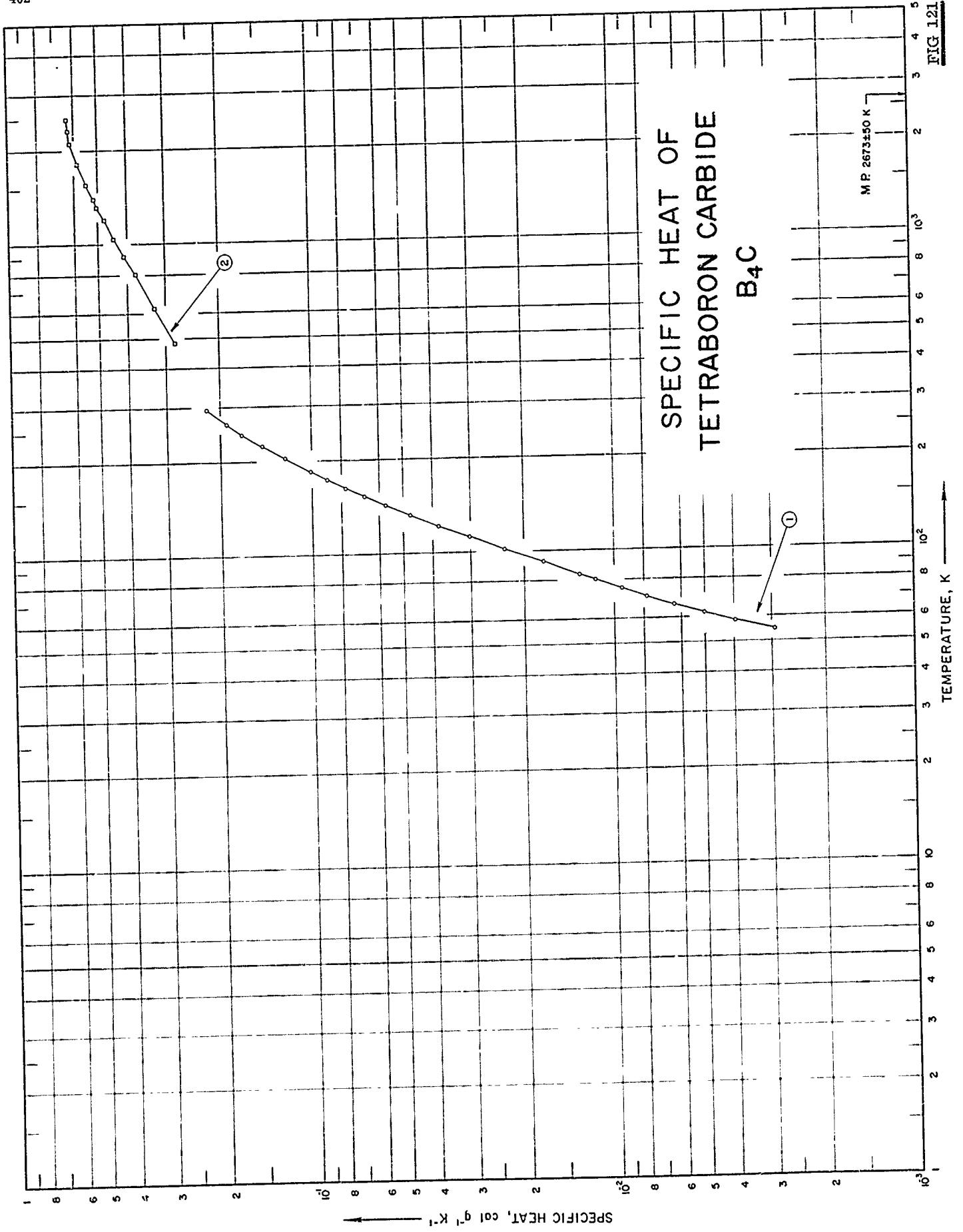

FIG 121

SPECIFICATION TABLE NO. 121 SPECIFIC HEAT OF TETRABORON CARBIDE B_4C

[For Data Reported in Figure and Table No. 121]

Curve No.	Ref. No.	Year	Temp. Range, K	Reported Error, %	Name and Specimen Designation	Composition (weight percent), Specifications and Remarks
1	50	1941	54-294	0.5		96 B_4C and 4 free and included graphite; corrected for graphite.
2	47	1963	482-2510	± 5		75.97 B, 21.18 C, 0.07 B_2O_3 , 0.27 Fe, 0.40 Si, and 0.015 Al_2O_3 ; sample supplied by the Carborundum Co; hot pressed at 3940F; density 156 lb ft ⁻³ .

DATA TABLE NO. 121 SPECIFIC HEAT OF TETRABORON CARBIDE B_4C
 [Temperature, T, K; Specific Heat, C_p , Cal $g^{-1} K^{-1}$]

T	C_p	
	CURVE 1	CURVE 2 (cont.)
54.5	2.930×10^{-3}	5.040×10^{-1}
58.5	3.961	5.199
62.3	5.028	5.349*
66.2	6.348	5.493
70.6	7.813	5.596*
75.0	9.459	5.828
80.1	1.154×10^{-2}	5.975*
83.6	1.311	6.149
92.1	1.744	6.233*
102.0	2.317	6.279
112.7	3.062	6.307
122.7	3.843	
133.0	4.759	
143.4	5.733	
153.5	6.723	
163.6	7.790	
174.1	8.933	
184.3	1.007×10^{-1}	
194.0	1.115	
204.1	1.234	
214.0	1.351	
224.3	1.469	
234.5	1.589	
244.7	1.704	
254.8	1.818	
264.9	1.928	
275.3	2.049	
284.5	2.143	
294.3	2.235	
CURVE 2		
481.48	2.820×10^{-1}	
624.82	3.275	
800.37	3.797	
840.93	3.910*	
915.93	4.112	
1049.26	4.449	
1092.04	4.551*	
1200.93	4.798	
1205.33	4.809*	
1247.04	4.897*	
1258.15	4.920*	

* Not shown on plot

FIG 122

SPECIFIC HEAT OF CALCIUM DICARBIDE CaC₂

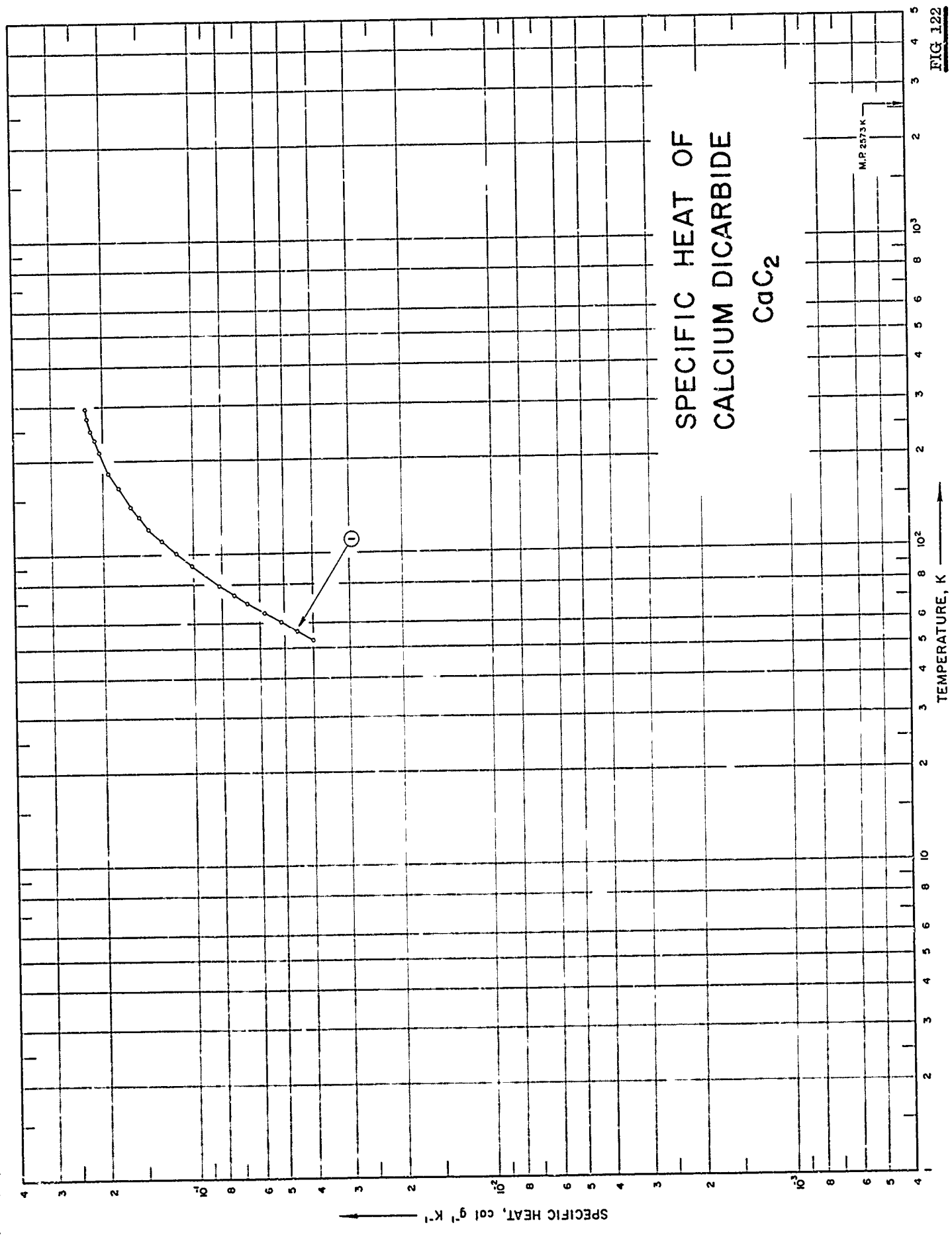

SPECIFICATION TABLE NO. 122 SPECIFIC HEAT OF CALCIUM DICARBIDE CaC_2

[For Data Reported in Figure and Table No. 122]

Curve No.	Ref. No.	Year	Temp. Range, K	Reported Error, %	Name and Specimen Designation	Composition (weight percent), Specifications and Remarks
1	178	1941	53-295			91.0 CaC_2 , 6.47 CaO , 1.15 SiO_2 , 0.77 Al_2O_3 , 0.29 Fe , 0.2 C , and 0.08 MgO ; sample supplied by the National Carbide Corp; corrected for impurities.

DATA TABLE NO. 122 SPECIFIC HEAT OF CALCIUM DICARBIDE CaC_2
 [Temperature, T, K; Specific Heat, C_p , Cal $\text{g}^{-1} \text{K}^{-1}$]

T	C_p
CURVE 1	
53.0	4.02×10^{-2}
56.8	4.55
60.7	5.16
65.0	5.88
69.7	6.65
74.0	7.35
79.6	8.28
83.2	8.79*
92.0	1.016×10^{-1}
101.9	1.156
112.5	1.296
122.7	1.422
133.0	1.534
143.7	1.640
153.6	1.715*
164.1	1.797
174.0	1.867*
184.3	1.933
194.6	1.991
204.9	2.036*
214.7	2.078
224.5	2.117*
235.1	2.154
245.0	2.192*
254.9	2.220
265.2	2.243*
275.8	2.285
285.7	2.309*
295.0	2.318

* Not shown on plot

FIGURE SHOWS ONLY 3 OF THE CURVES REPORTED IN TABLE

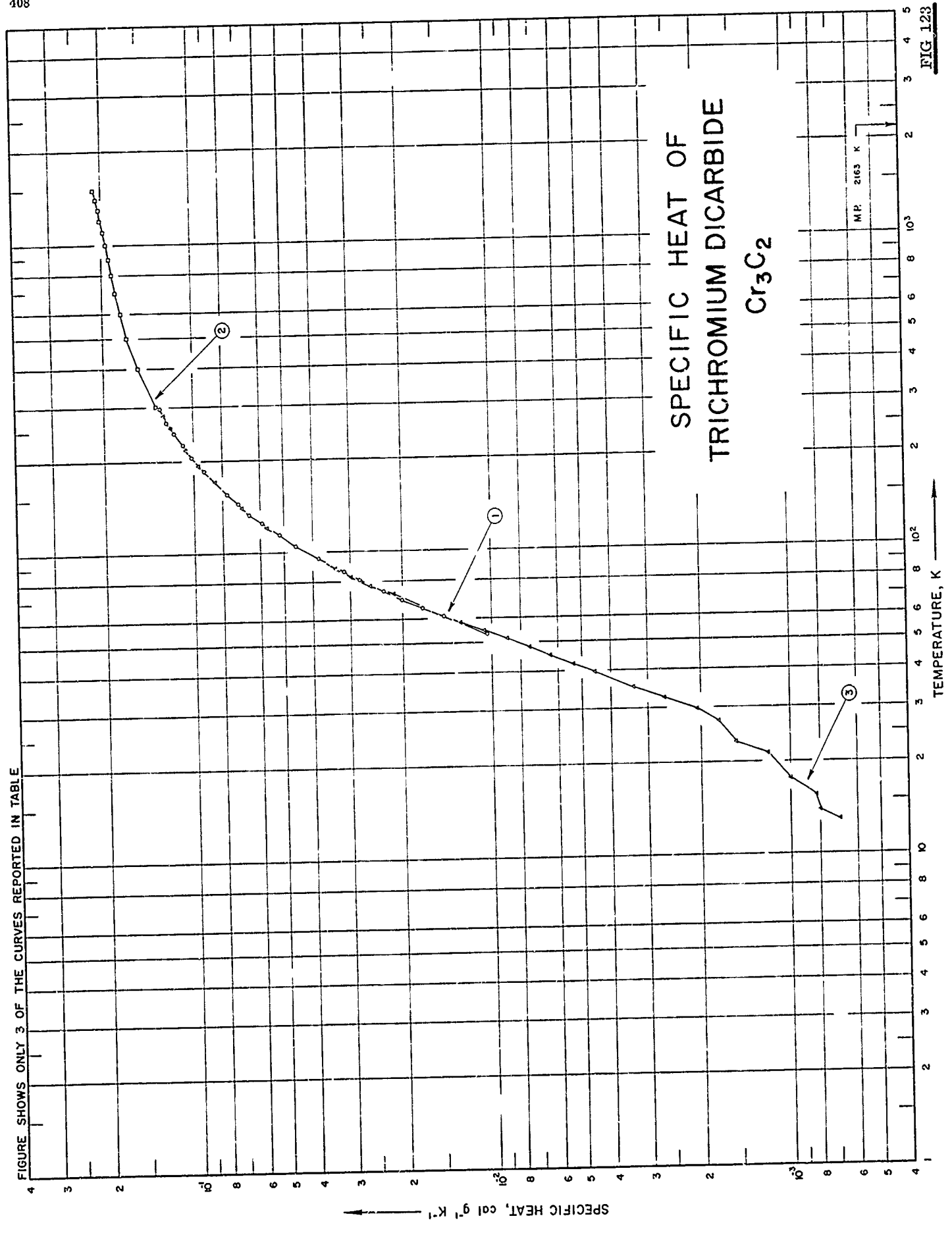

FIG 123

SPECIFICATION TABLE NO. 123 SPECIFIC HEAT OF TRICHRONIUM DICARBIDE Cr_3C_2

[For Data Reported in Figure and Table No. 123]

Curve No.	Ref. No.	Year	Temp. Range, K	Reported Error, %	Name and Specimen Designation	Composition (weight percent), Specifications and Remarks
1	61	1944	53-295			98.67 Cr_3C_2 , 0.98 Cr_2O_3 , and 0.25 uncombined C.
2	61	1944	298-1500			98.77 Cr_3C_2 , 0.98 Cr_2O_3 , and 0.25 uncombined C.
3	179	1953	12-300			86.2 Cr, 13.2 \pm 4 C (theor. 86.67 Cr and 13.3 C), small amounts of metallic Cr, trace of Al, Cu, Fe, and Mg; prepared from Cr_2O_3 and lampblack in H_2 furnace at 1525 C.
4	180	1954	273-1200			86.2 Cr, 13.2 \pm 4 C, small amounts of Cr, traces of Al, Cu, Fe, and Mg.

DATA TABLE NO. 123 SPECIFIC HEAT OF TRICHRORIUM DICARBIDE Cr_2C_2
 [Temperature, T, K; Specific Heat, C_p , Cal $\text{g}^{-1} \text{K}^{-1}$]

T	C_p	T	C_p	T	C_p	T	C_p		
CURVE 1									
53.4	1.041×10^{-2}	1000	1.937×10^{-1}	135.20	6.532×10^{-2} *	500.00	1.613×10^{-1}		
57.2	1.235*	1100	1.975	141.84	6.948	600.00	1.698		
61.1	1.463	1200	2.041	148.84	7.403*	700.00	1.770		
65.1	1.719	1300	2.046	155.16	7.881*	800.00	1.835		
69.4	2.001	1400	2.081	162.84	8.270*	900.00	1.896		
74.2	2.329	1500	2.114	170.12	8.459	1000.00	1.955		
81.0	2.499	CURVE 3						1100.00	2.012
86.1	3.159	12.90	6.720×10^{-4}	185.97	9.347*	1200.00	2.068		
95.6	3.847	13.82	7.998	193.60	9.653				
105.3	4.530	15.51	8.220	201.01	1.004×10^{-1} *				
114.9	5.196	17.66	9.997	208.14	1.030*				
125.5	5.909	21.25	1.189×10^{-3}	212.17	1.042*				
135.2	6.543	23.16	1.522	218.88	1.068				
145.4	7.148	27.63	1.727	225.22	1.088*				
156.0	7.765	29.82	2.055	231.21	1.106*				
165.7	8.298*	32.44	2.644	236.86	1.126*				
175.5	8.792*	35.22	3.355	242.12	1.143*				
185.9	9.286	42.13	5.332	247.33	1.166*				
196.0	9.753*	45.16	6.365	251.75	1.182*				
206.2	1.017×10^{-1}	48.28	7.492	256.06	1.192				
216.0	1.058*	51.48	8.909	260.64	1.210*				
226.1	1.096	54.57	1.060×10^{-2}	265.06	1.224*				
236.3	1.130*	58.12	1.289	269.40	1.237*				
246.5	1.169	62.28	1.483*	272.49	1.245*				
256.4	1.198*	66.82	1.721*	276.42	1.260*				
266.2	1.230	71.99	2.177	280.48	1.265				
276.8	1.260*	77.15	2.577	282.61	1.275*				
286.2	1.281*	79.91	2.769*	284.40	1.284*				
295.2	1.295	82.91	2.988	286.23	1.281*				
CURVE 2									
298.15	1.298×10^{-1} *	84.42	2.969*	288.70	1.286*				
300	1.304	88.17	3.366	290.07	1.289*				
400	1.535	93.52	3.749*	293.70	1.297*				
500	1.658	99.41	4.152*	297.30	1.300*				
600	1.740	105.89	4.612*	300.71	1.311*				
700	1.801	113.13	5.126*	CURVE 4*					
800	1.852	121.83	5.704	273.15	1.247×10^{-1}				
900	1.896	128.70	6.115*	300.00	1.321				
				400.00	1.501				

*Not shown on plot

SPECIFIC HEAT OF
PENTACHROMIUM DICARBIDE
 Cr_5C_2

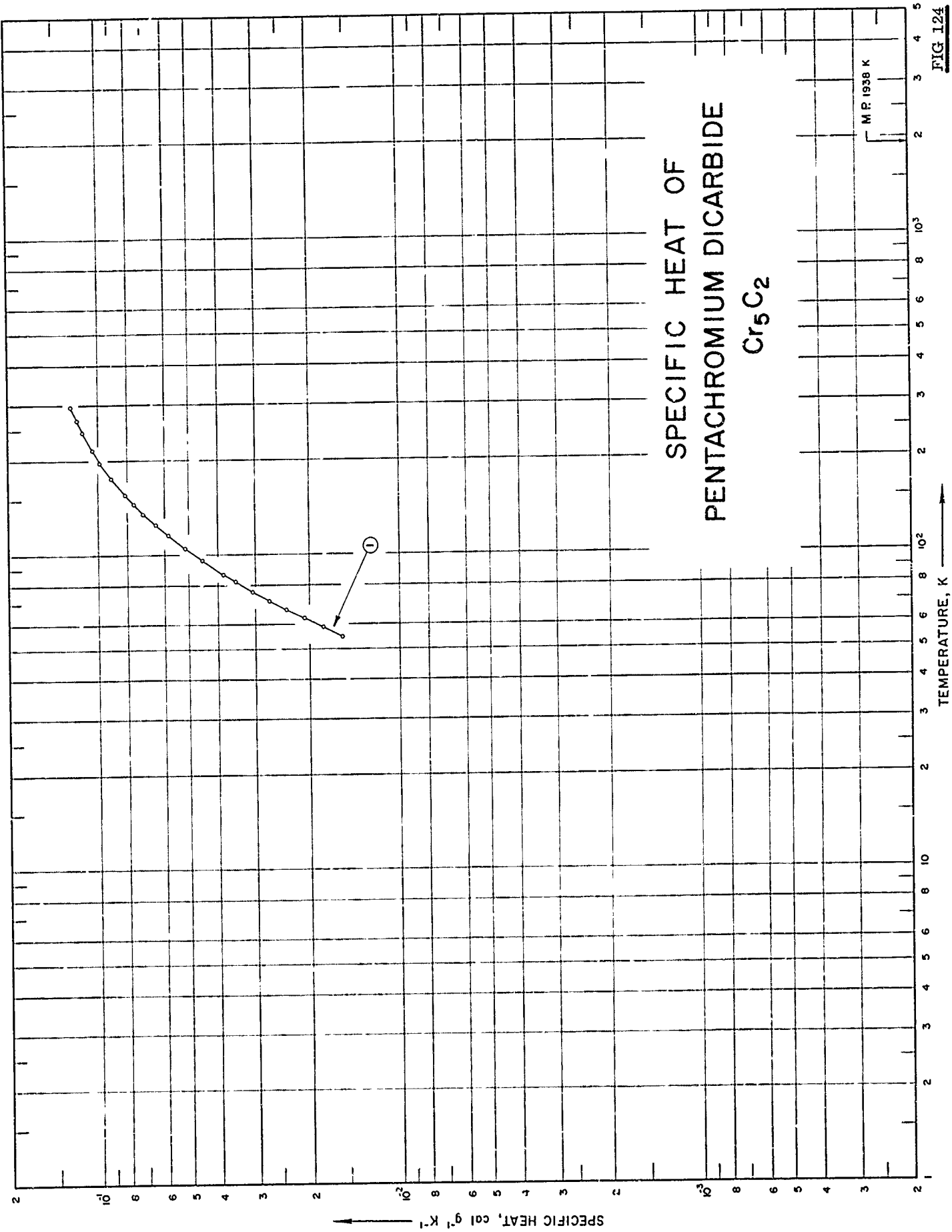

FIG 124

SPECIFICATION TABLE NO. 124 SPECIFIC HEAT OF PENTACHROMIUM DICARBIDE Cr_5C_2

[For Data Reported in Figure and Table No. 124]

Curve No.	Ref. No.	Year	Temp. Range, K	Reported Error, %	Name and Specimen Designation	Composition (weight percent), Specifications and Remarks
1	61	1944	53-295			99.6 Cr_5C_2 , 0.4 Cr_2O_3 .

DATA TABLE NO. 124 SPECIFIC HEAT OF PENTACHROMIUM DICARBIDE Cr_5C_2
 [Temperature, T, K; Specific Heat, C_p , Cal $\text{g}^{-1} \text{K}^{-1}$]

T	C_p
CURVE I	
54.8	1.553×10^{-2}
58.7	1.802
62.6	2.082
66.9	2.391
71.4	2.727
76.3	3.084
79.3	3.298*
82.2	3.516
86.7	3.851
96.3	4.52 ^o
105.3	5.164
116.0	5.868
125.5	6.477
136.4	7.111
146.2	7.635
156.0	8.121
166.6	8.628*
176.2	9.033
186.8	9.445*
197.8	9.867
206.6	1.016×10^{-1} *
216.3	1.045
226.7	1.078*
236.8	1.103*
246.7	1.132
256.5	1.153*
263.9	1.180
276.8	1.203*
286.0	1.216*
295.3	1.230

* Not shown on plot

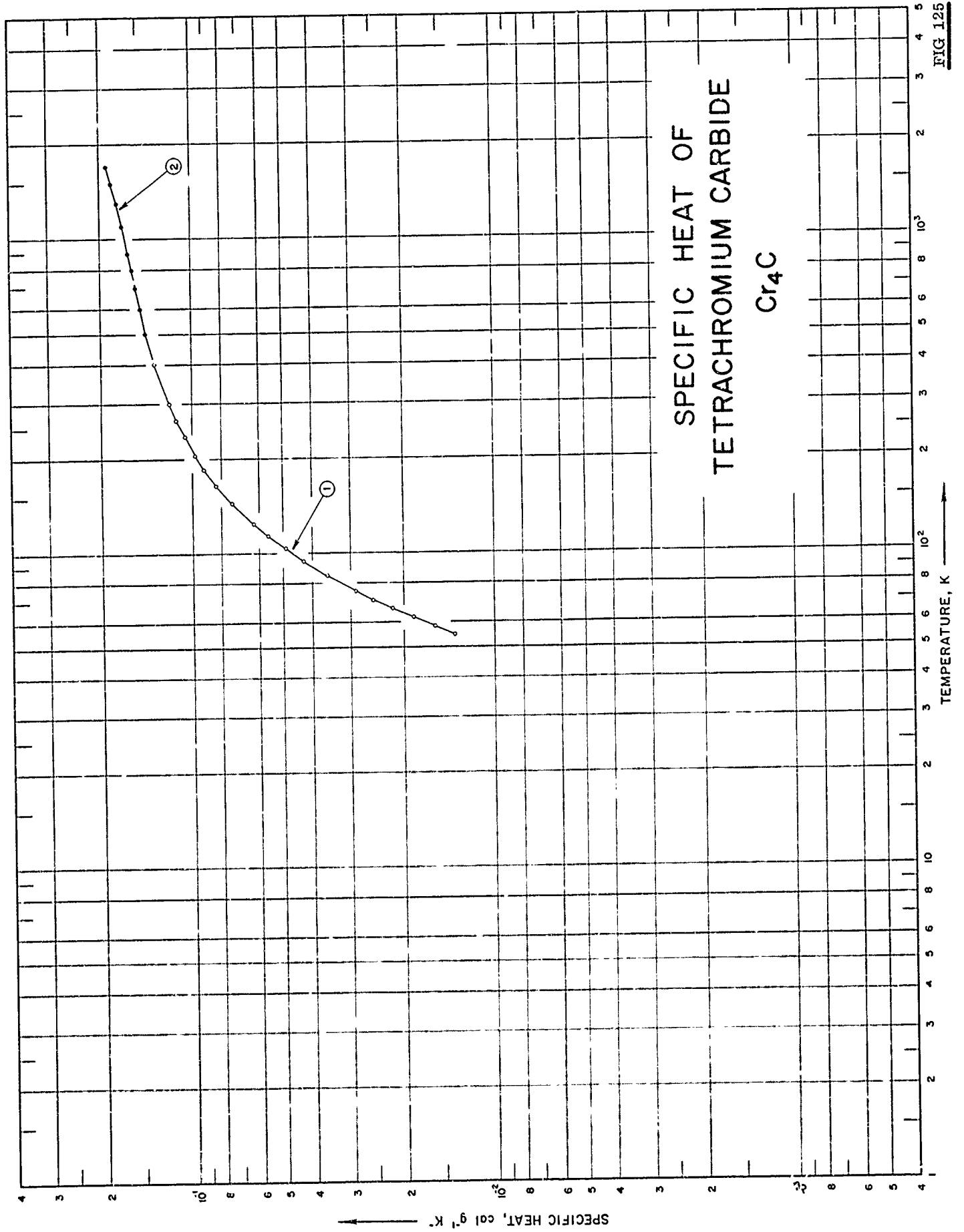

FIG 125

SPECIFICATION TABLE NO. 125 SPECIFIC HEAT OF TETRACHROMIUM CARBIDE Cr_4C

[For Data Reported in Figure and Table No. 125]

Curve No.	Ref. No.	Year	Temp. Range, K	Reported Error, %	Name and Specimen Designation	Composition (weight percent), Specifications and Remarks
1	61	1944	53-295			~100 Cr_4C .
2	61	1944	298-1700			~100 Cr_4C .

DATA TABLE NO. 125 SPECIFIC HEAT OF TETRACHROMIUM CARBIDE Cr₄C[Temperature, T, K; Specific Heat, C_p, Cal g⁻¹ K⁻¹]

T	C _p	
	CURVE 1	CURVE 2 (cont.)
54.6	1.351 x 10 ⁻²	1300 1.757 x 10 ⁻¹
58.1	1.583	1400 1.793*
62.2	1.866	1500 1.828
66.5	2.192	1600 1.863*
70.7	2.521	1700 1.897
75.5	2.885	
80.3	3.259*	
84.5	3.575	
93.9	4.273	
103.1	4.926	
113.6	5.626	
124.0	6.276	
134.6	6.889*	
144.6	7.398	
154.4	7.871*	
164.9	8.334	
174.7	8.712*	
185.0	9.121	
195.1	9.461*	
205.4	9.761	
215.2	1.003 x 10 ⁻¹ *	
225.5	1.031*	
236.1	1.057	
245.6	1.082*	
255.3	1.103*	
266.1	1.126	
276.5	1.150*	
285.8	1.162*	
295.0	1.170*	
CURVE 2		
298.15	1.178 x 10 ⁻¹ *	
300	1.181	
400	1.326	
500	1.411	
600	1.472	
700	1.523	
800	1.567	
900	1.608	
1000	1.647*	
1100	1.685	
1200	1.721*	

* Not shown on plot

FIG. 126

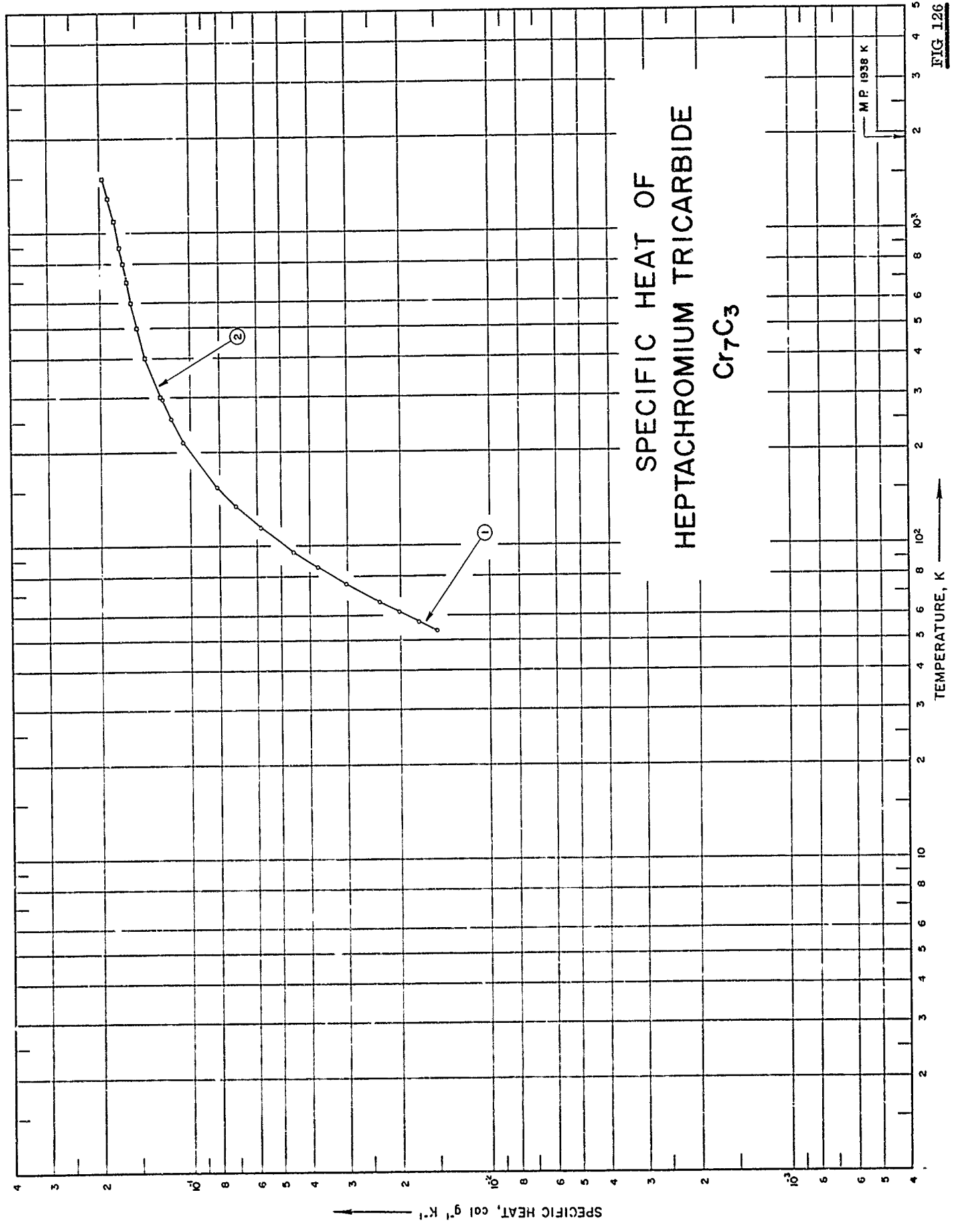

SPECIFICATION TABLE NO. 126 SPECIFIC HEAT OF HEPTACHROMIUM TRICARBIDE Cr_7C_3

[For Data Reported in Figure and Table No. 126]

Curve No.	Ref. No.	Year	Temp. Range, K	Reported Error, %	Name and Specimen Designation	Composition (weight percent), Specifications and Remarks
1	61	1944	53-295			$\sim 100 \text{ Cr}_7\text{C}_3$
2	61	1944	298-1500	max. dev. 0.6 av. dev. 2		$\sim 100 \text{ Cr}_7\text{C}_3$

DATA TABLE NO. 126 SPECIFIC HEAT OF HEPTACHROMIUM TRICARBIDE Cr_7C_3 [Temperature, T, K; Specific Heat, C_p , Cal $\text{g}^{-1} \text{K}^{-1}$]

T	C_p		T	C_p
	CURVE 1	CURVE 2 (cont.)		
53.8	1.509×10^{-2}	$1.838 \times 10^{-1*}$	1200	1.877
57.4	1.740	1.877	1300	1.915 [*]
61.7	2.023	1.915 [*]	1400	1.953
66.4	2.369		1500	
71.0	2.702			
75.6	3.032			
81.1	3.439 [*]			
85.8	3.789			
95.6	4.501			
105.4	5.171 [*]			
115.2	5.829			
125.2	6.468 [*]			
135.2	7.061			
145.7	7.631 [*]			
156.1	8.166			
165.9	8.638 [*]			
176.3	9.080			
185.9	9.490 [*]			
196.5	9.868 [*]			
206.3	$1.021 \times 10^{-1*}$			
216.5	1.053			
226.2	1.084 [*]			
236.7	1.112 [*]			
246.5	1.140 [*]			
256.4	1.164			
266.0	1.188 [*]			
276.6	1.212 [*]			
286.0	1.229 [*]			
295.3	1.243			
<u>CURVE 2</u>				
298	$1.247 \times 10^{-1*}$			
300	1.252			
400	1.411			
500	1.503			
600	1.570			
700	1.625			
800	1.673			
900	1.717			
1000	1.756 [*]			
1100	1.799			

^{*}Not shown on plot

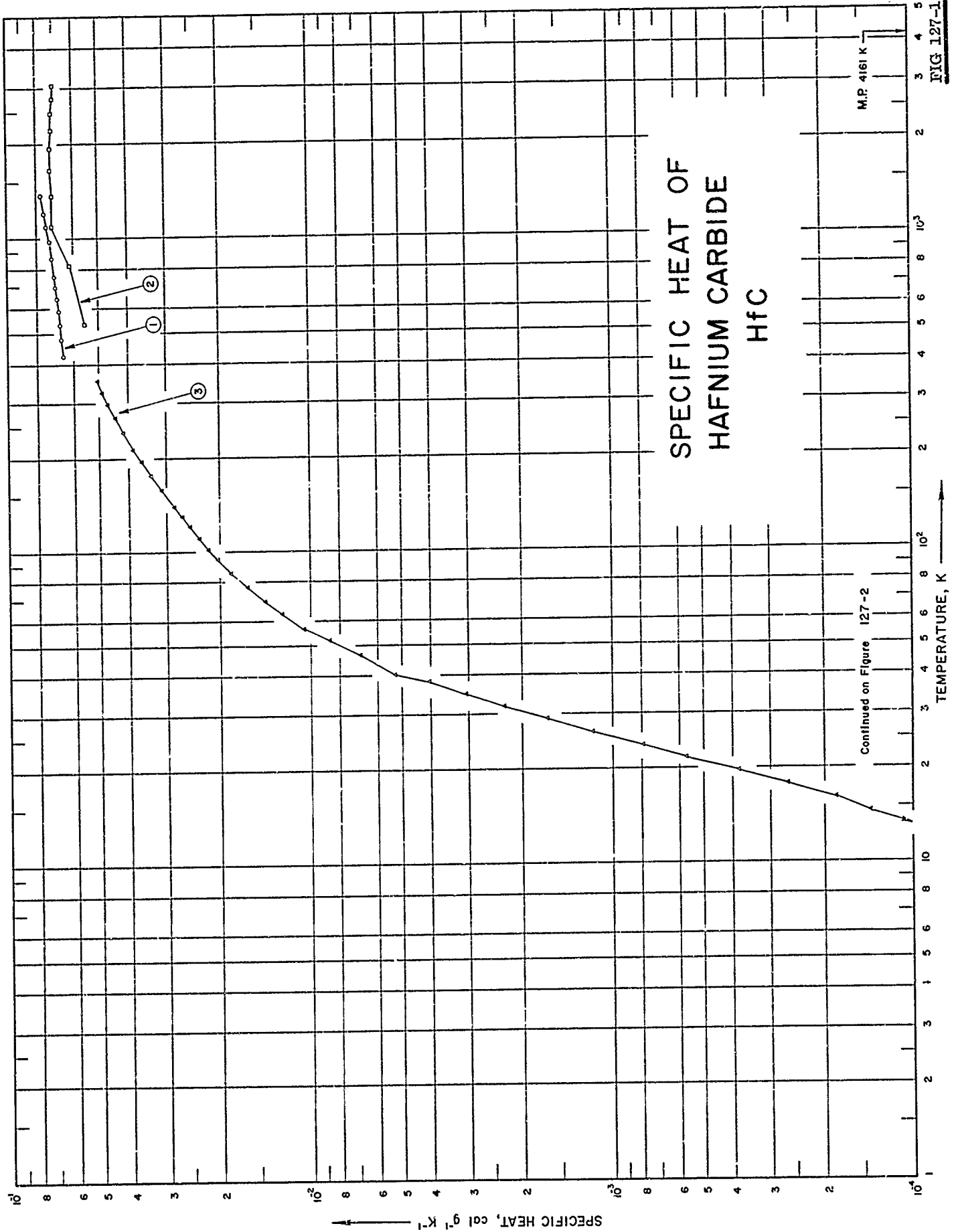
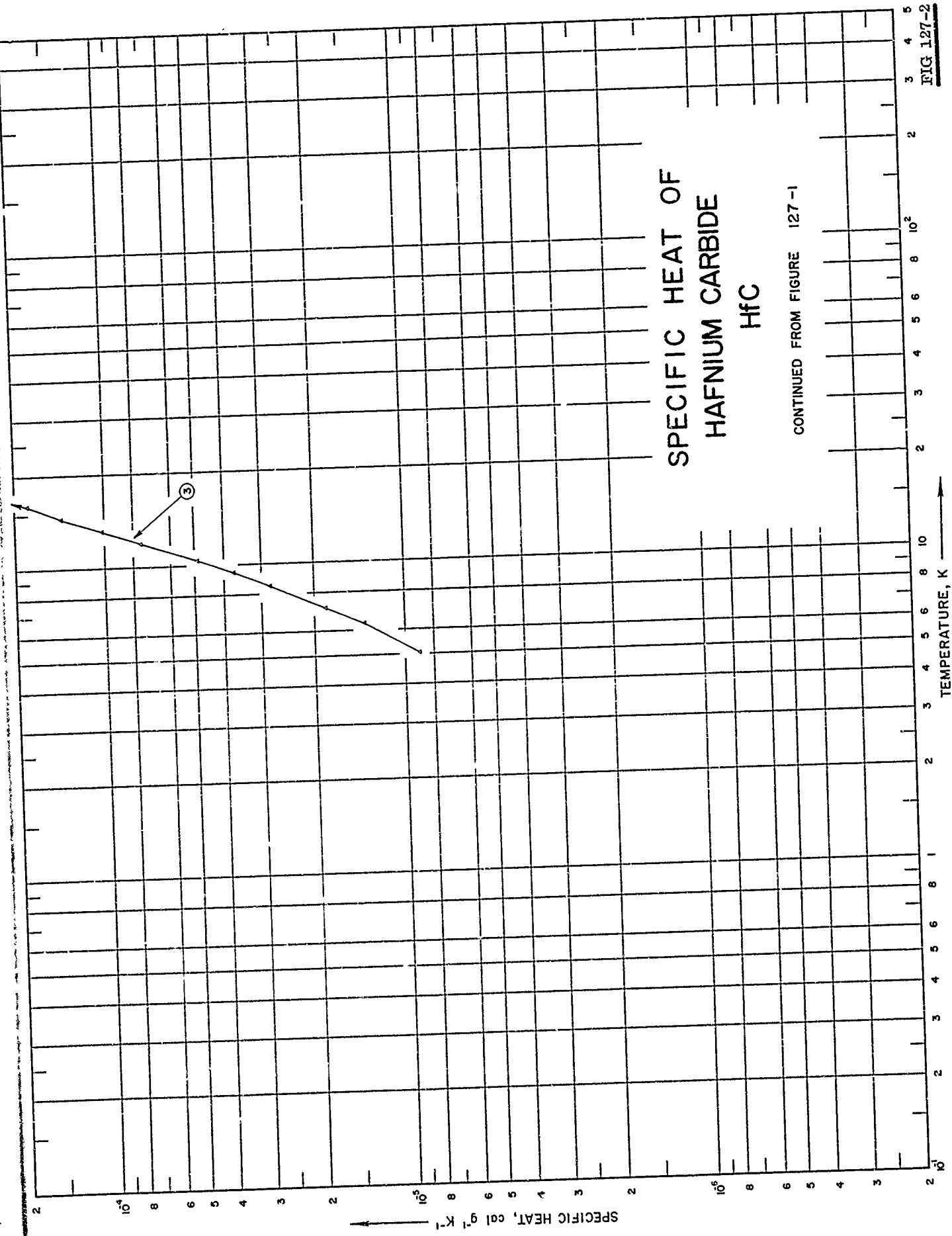

FIG 127-1

SPECIFIC HEAT OF HAFNIUM CARBIDE HfC

CONTINUED FROM FIGURE 127-1



SPECIFIC HEAT, cal g⁻¹ K⁻¹

TEMPERATURE, K

SPECIFICATION TABLE NO. 127 SPECIFIC HEAT OF HAFNIUM CARBIDE HfC

[For Data Reported in Figure and Table No. 127]

Curve No.	Ref. No.	Year	Temp. Range, K	Reported Error, %	Name and Specimen Designation	Composition (weight percent), Specifications and Remarks
1	76	1961	422-1366	5.0		Before spraying 79.8 Hf, 5.38 C; sample made from powder HfC by spraying with powder gun using nitrogen-hydrogen plasma gas and 8 ft ³ hr ⁻¹ nitrogen carrier gas.
2	32	1962	533-3033	±5		Before exposure: 93.8 Hf, 5.85 C, 1.0 N, 0.3 Ti, and 0.2 Al, after exposure 93.9 Hf, 5.73 C, 0.9 N; sample supplied by the Carborundum Co; hot pressed; density at 25 C, before exposure: apparent density (ASTM method B311-58) 700 lb ft ⁻³ , true density (by immersion in xylene) 750 lb ft ⁻³ , after exposure: apparent density 700 lb ft ⁻³ , true density 730 lb ft ⁻³ .
3	165	1964	5-350			Bal. Hf, 6.12 C, 0.035 Zr, 0.031 N, 0.005 Fe, 0.003 O, 0.002 Ti, Si, 0.001 H, Cu, and Mg; zone-refined.

DATA TABLE NO. 127 SPECIFIC HEAT OF HAFNIUM CARBIDE HfC

[Temperature, T, K; Specific Heat, Cp, Cal g⁻¹ K⁻¹]

T	Cp	T	Cp	T	Cp
<u>CURVE 1</u>					
422.03	6.540 x 10 ⁻²	16.15	1.801 x 10 ⁻⁴	313.74	4.815 x 10 ⁻² *
477.59	6.620	17.89	2.662	322.37	4.873
533.15	6.690	19.75	3.774	331.16	4.931*
588.70	6.760	21.75	5.664	339.68	4.982*
644.26	6.830	23.81	7.880	346.90	5.030*
699.81	6.900	26.36	1.152 x 10 ⁻³	350.00	5.046
755.37	6.970	29.03	1.636		
810.92	7.040*	31.88	2.266		
866.48	7.110	34.91	3.041		
922.03	7.150*	38.29	4.069		
977.59	7.200*	42.24	5.256		
1033.15	7.330*	46.93	6.823		
1088.70	7.400	52.22	8.615		
1144.26	7.470*	57.97	1.270		
1199.81	7.540	63.77	1.413		
1255.37	7.610*	69.85	1.616		
1310.92	7.680*	77.17	1.831		
1366.78	7.760	85.67	1.824		
		95.28	2.034*		
		102.52	2.175		
		111.39	2.341		
		120.68	2.506		
		129.96	2.664		
		139.20	2.819		
		148.56	2.967*		
		157.91	3.112		
		167.14	3.249*		
		176.27	3.382		
		185.46	3.509*		
		194.79	3.633		
		203.96	3.751*		
		212.90	3.863		
		221.97	3.970*		
		231.05	4.074*		
		240.11	4.172		
		249.29	4.265*		
		258.53	4.359*		
		267.88	4.441		
		277.07	4.525*		
		286.20	4.606*		
		295.35	4.678		
		304.47	4.748*		
<u>CURVE 2</u>					
533.15	5.500 x 10 ⁻²				
810.92	6.700				
1088.70	7.100				
1366.48	7.100				
1644.26	7.200				
1922.03	7.200				
2199.81	7.100				
2477.59	7.100				
2755.37	7.000				
3033.15	7.000				
<u>CURVE 3</u>					
5.09	8.924 x 10 ⁻⁶				
6.39	1.365 x 10 ⁻⁵				
7.16	1.837				
8.50	2.782				
9.50	3.675				
10.50	4.882				
12.09	7.507				
13.25	1.018 x 10 ⁻⁴				
14.59	1.331				

* Not shown on plot

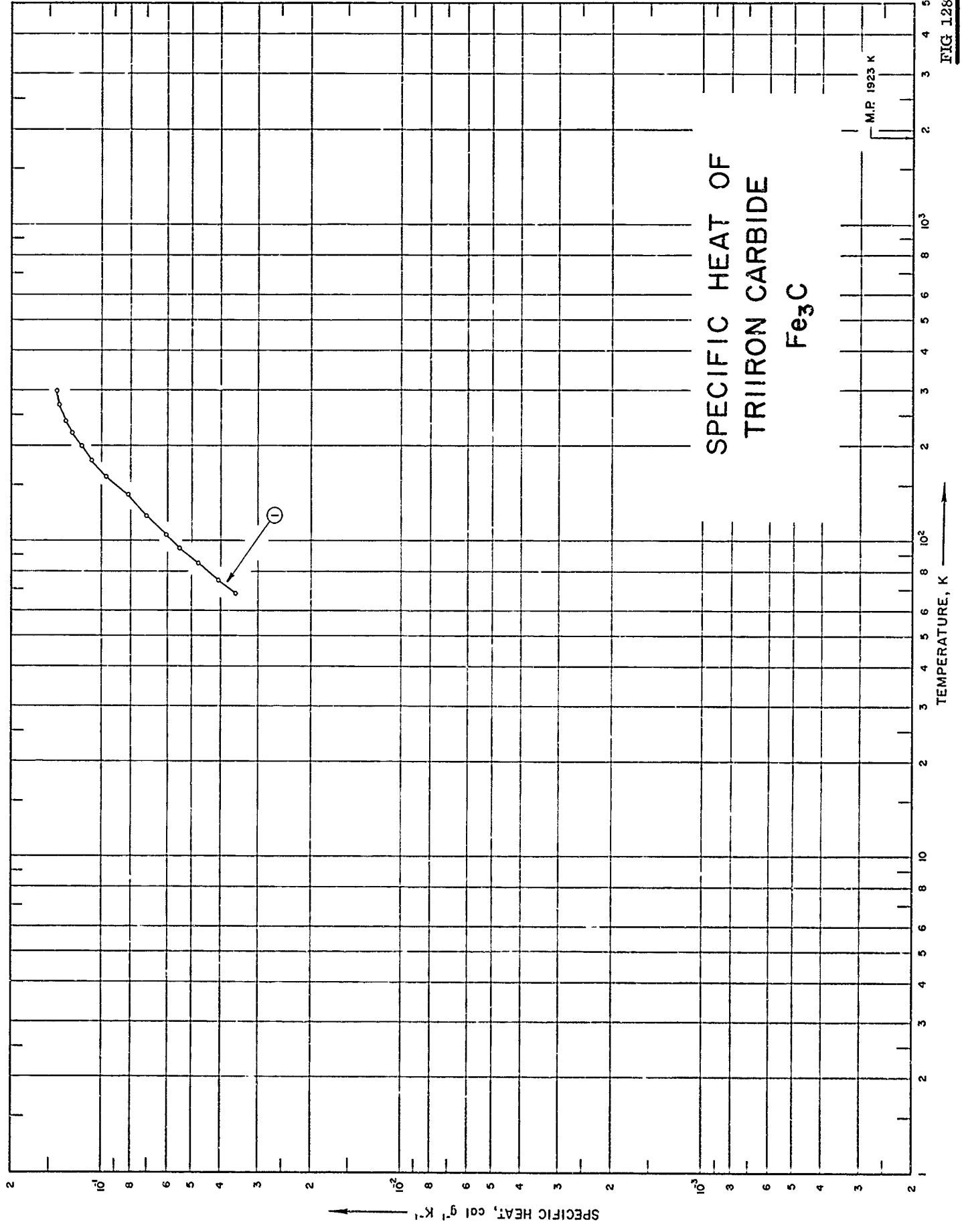

FIG 128

SPECIFICATION TABLE NO. 128 SPECIFIC HEAT OF TRIRON CARBIDE Fe₃C

[For Data Reported in Figure and Table No. 128]

Curve No.	Ref. No.	Year	Temp. Range, K	Reported Error, %	Name and Specimen Designation	Composition (weight percent), Specifications and Remarks
1	181	1939	68-298	2		

DATA TABLE NO. 128 SPECIFIC HEAT OF TRIRON CARBIDE Fe₃C[Temperature, T, K; Specific Heat, Cp, Cal g⁻¹ K⁻¹]

T	Cp
	CURVE 1
	3.570 x 10 ⁻²
68.00	4.060
75.00	4.450*
80.00	4.751
85.00	5.135*
90.00	5.492
95.00	5.848*
100.00	6.099
105.00	6.450*
110.00	7.067
120.00	7.491
130.00	8.149
140.00	8.867*
150.00	9.608
160.00	1.029 x 10 ⁻¹ *
170.00	1.087
180.00	1.133*
190.00	1.172
200.00	1.208*
210.00	1.252
220.00	1.282*
230.00	1.317
240.00	1.345*
250.00	1.372*
260.00	1.386
270.00	1.400*
280.00	1.405*
290.00	1.411
298.00	

* Not shown on plot

FIG. 129

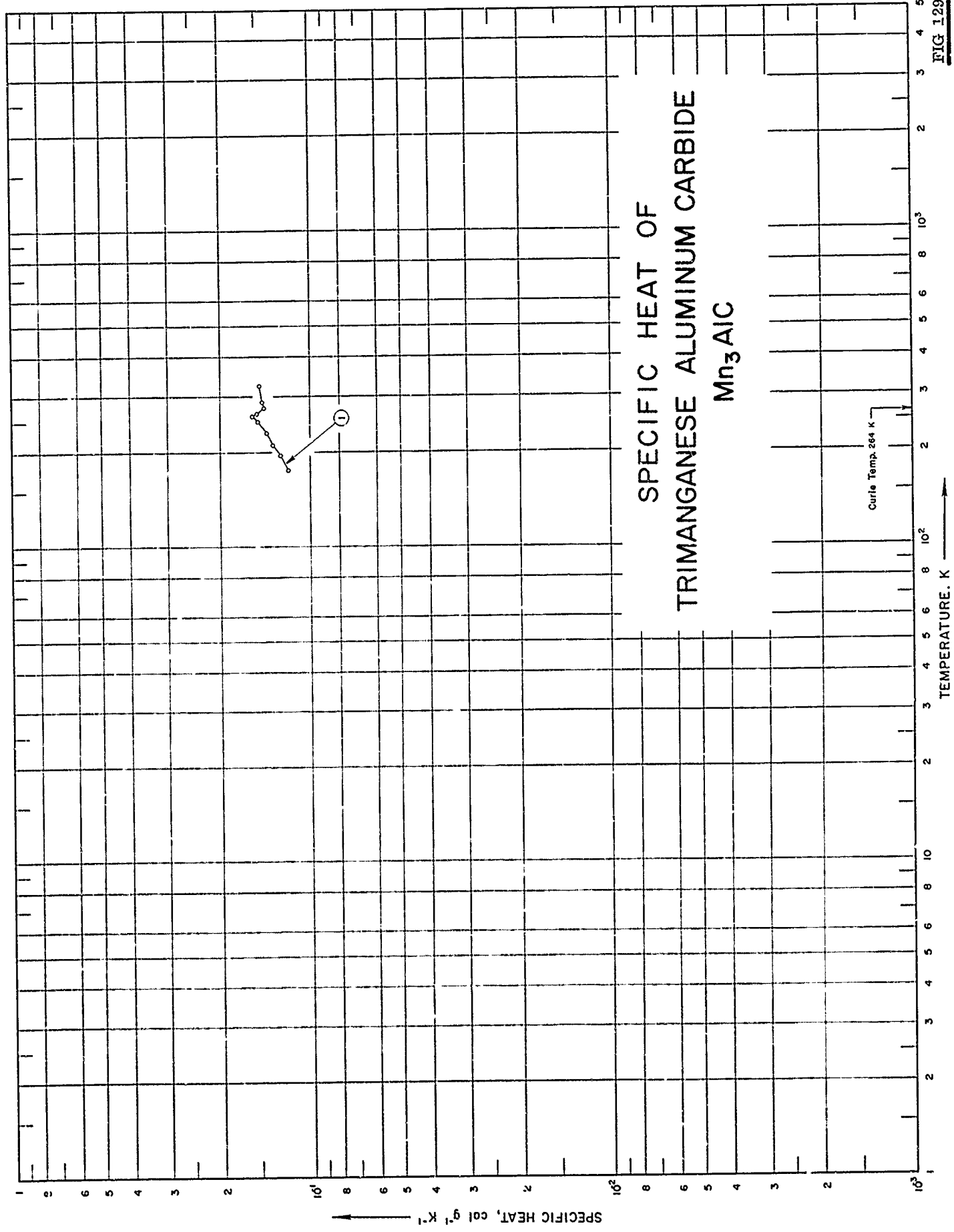

SPECIFICATION TABLE NO. 129 SPECIFIC HEAT OF TRIMANGANESE ALUMINUM CARBIDE Mn_3AlC

[For Data Reported in Figure and Table No. 129]

Curve No.	Ref. No.	Year	Temp. Range, K	Reported Error, %	Name and Specimen Designation	Composition (weight percent), Specifications and Remarks
1	182	1962	176-325	0.5		>99.9 Mn_3AlC ; prepared from >99.9% purity materials.

DATA TABLE NO. 129 SPECIFIC HEAT OF TRIMANGANESE ALUMINUM CARBIDE Mn_3AlC
 [Temperature, T, K; Specific Heat, Cp, Cal $g^{-1} K^{-1}$]

T	Cp
176.15	1.187×10^{-1}
186.15	1.222*
197.15	1.257
211.15	1.335
216.15	1.338*
230.15	1.391
242.15	1.448*
250.65	1.496
254.15	1.526*
258.15	1.548*
260.15	1.548*
262.15	1.555
266.15	1.511
271.15	1.448*
272.15	1.430*
277.15	1.421
279.15	1.426*
289.15	1.440
305.15	1.458*
315.15	1.461*
325.15	1.475

CURVE 1

Not shown on plot

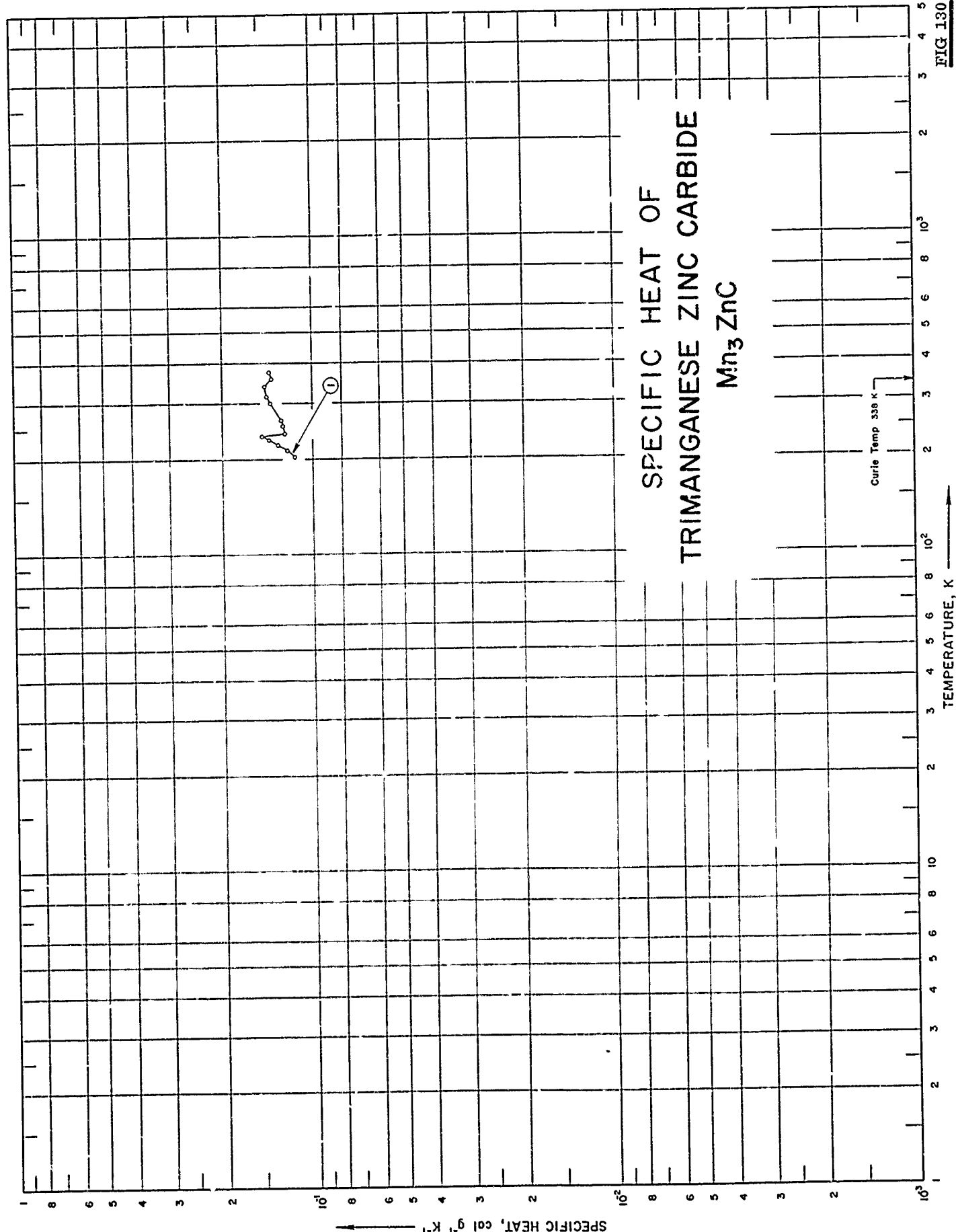

FIG 130

SPECIFICATION TABLE NO. 130 SPECIFIC HEAT OF TRIMANGANESE ZINC CARBIDE Mn_3ZnC

[For Data Reported in Figure and Table No. 130]

Curve No.	Ref. No.	Year	Temp. Range, K	Reported Error, %	Name and Specimen Designation	Composition (weight percent), Specifications and Remarks
1	182	1962	204-375	± 5		>99.9 Mn_3ZnC ; prepared from >99.9% purity materials.

DATA TABLE NO. 130 SPECIFIC HEAT OF TRIMANGANESE ZINC CARBIDE Mn_3ZnC [Temperature, T, K; Specific Heat, C_p , Cal $g^{-1} K^{-1}$]

T	C_p
<u>CURVE 1</u>	
204	1.160 x 10 ⁻¹
214	1.218
218	1.243*
223	1.301
225	1.313*
225	1.325*
231	1.400
234	1.425*
234	1.445*
242	1.247
246	1.247*
255	1.264
266	1.276
302	1.383
305	1.379*
315	1.420
323	1.420*
330	1.445*
333	1.449*
340	1.449
343	1.445*
347	1.408*
347	1.396*
353	1.387*
355	1.375*
358	1.375
359	1.387*
367	1.375*
367	1.400*
375	1.396

* Not shown on plot

FIG 131

SPECIFIC HEAT OF
TRIMANGANESE CARBIDE
 Mn_3C

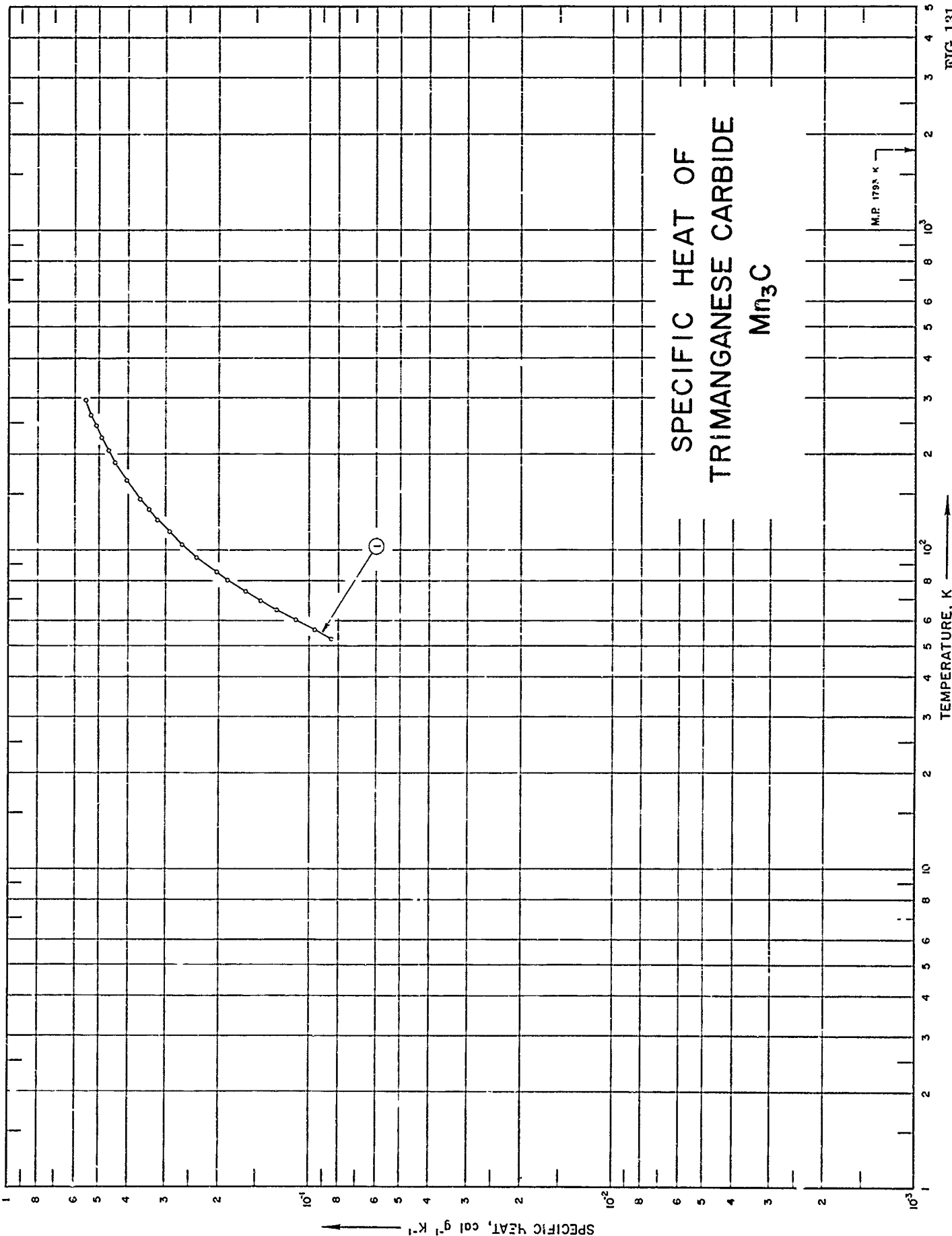

SPECIFICATION TABLE NO. 131 SPECIFIC HEAT OF TRIMANGANESE CARBIDE Mn_3C

[For Data Reported in Figure and Table No. 131]

Curve No.	Ref. No.	Year	Temp. Range, K	Reported Error, %	Name and Specimen Designation	Composition (weight percent), Specifications and Remarks
1	183	1943	52-295			98.8 Mn_3C ; 1.2 Mn not in separate phase, 93.15 Mn; 6.71 C (theor. 93.21 Mn and 6.79 C), <0.02 H_2 and 0.015 inorganic residue; prepared by heating electrolytic Mn and high purity C for 72 hrs at 850 K in vacuum, corrected for excess Mn.

DATA TABLE NO. 131 SPECIFIC HEAT OF TRIMANGANESE CARBIDE Mn_3C
 [Temperature, T, K; Specific Heat, C_p , Cal $g^{-1} K^{-1}$]

T	C_p
	CURVE 1
52.60	8.464×10^{-2}
56.00	9.594
60.30	1.111×10^{-1}
64.80	1.283
69.20	1.454
74.10	1.639
80.60	1.874
85.10	2.035
94.70	2.372
104.30	2.652
114.20	2.921
124.70	3.198
134.40	3.415
144.80	3.650
155.20	3.857*
165.10	4.041
175.40	4.211*
188.60	4.423
195.80	4.528*
205.50	4.657
215.70	4.782*
225.70	4.909
235.50	5.004*
245.30	5.119
255.50	5.219*
265.50	5.316
275.60	5.405*
285.30	5.473*
295.20	5.551

* Not shown on plot

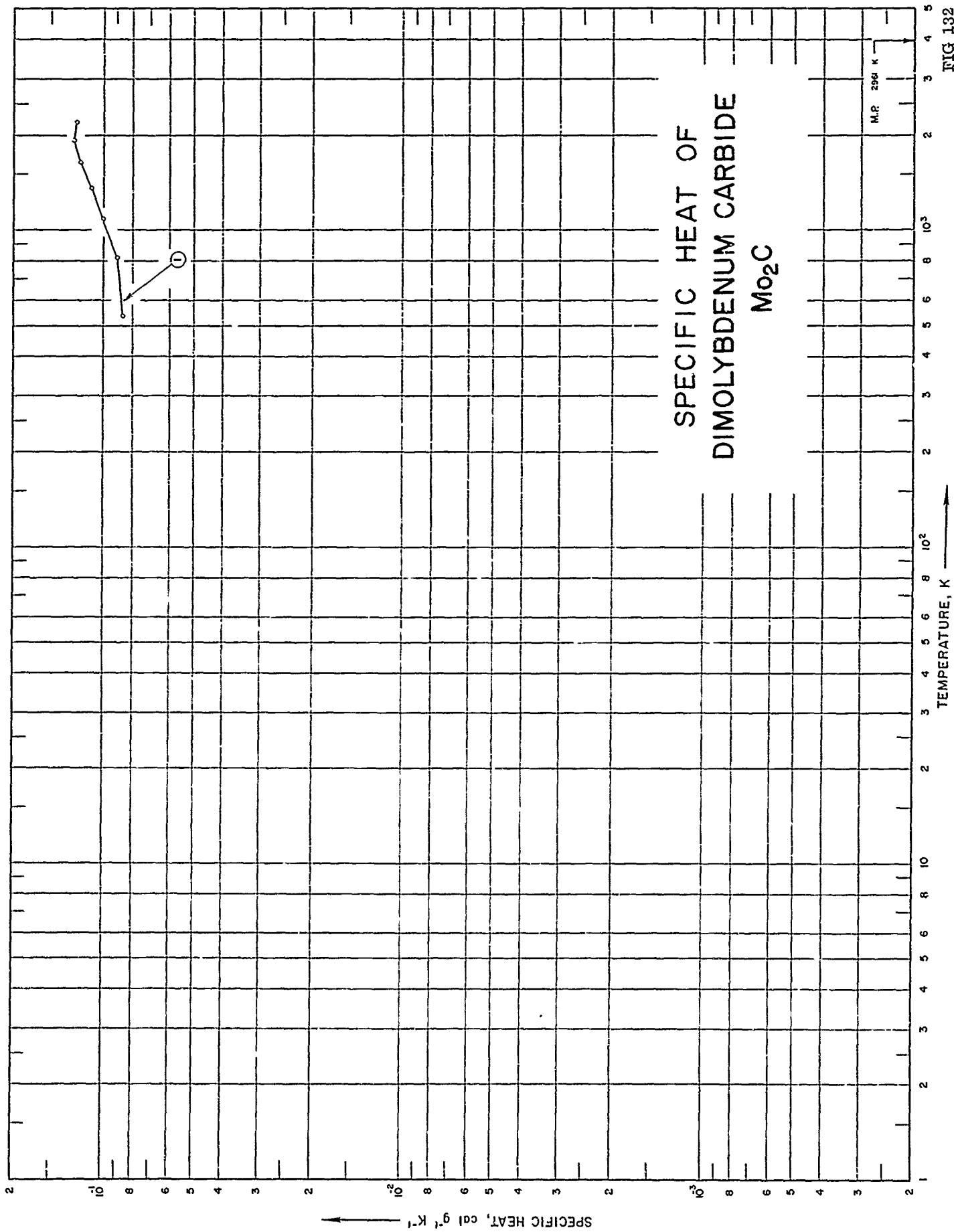

FIG 132

SPECIFICATION TABLE NO. 132 SPECIFIC HEAT OF DIMOLYBDENUM CARBIDE Mo₂C

[For Data Reported in Figure and Table No. 132]

Curve No.	Ref. No.	Year	Temp. Range, K	Reported Error, %	Name and Specimen Designation	Composition (weight percent). Specifications and Remarks
1	48	1962	533-2200	≤5		<p>Before exposure: 92.1 Mo, 5.51 C, 2.0 Si, 0.6 Fe, 0.3 Ti, 0.2 Al, and <0.1 N, after exposure: 92.4 Mo, 5.39 C, <0.1 N; sample supplied by the Carborundum Co.; crushed in hardened steel mortar to pass 100-mesh screen; hot pressed; density at 25 C, before exposure: apparent density (ASTM method B311-58) 554 lb ft⁻³, true density (by immersion in xylene) 560 lb ft⁻³, after exposure: apparent density 535 lb ft⁻³, true density 542 lb ft⁻³.</p>

DATA TABLE NO. 132 SPECIFIC HEAT OF DIMOLYBDENUM CARBIDE Mo₂C[Temperature, T, K; Specific Heat, C_p, Cal g⁻¹ K⁻¹]

T	C _p
533.15	8.600 x 10 ⁻²
810.93	9.000
1088.71	1.010 x 10 ⁻¹
1366.48	1.100
1644.26	1.200
1922.04	1.260
2199.82	1.240

CURVE 1

* Not shown on plot

FIG 133

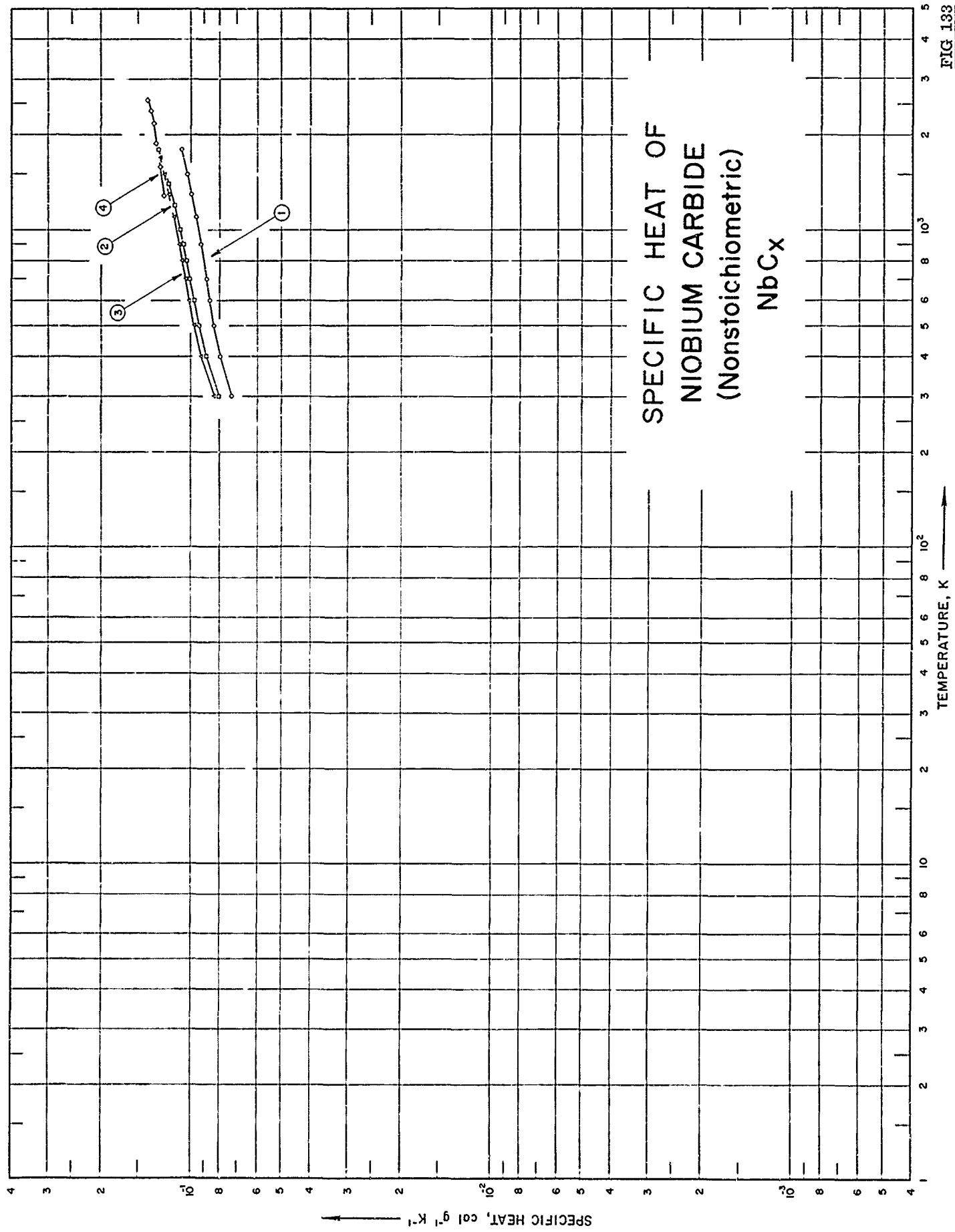

SPECIFICATION TABLE NO. 133 SPECIFIC HEAT OF NIOBIUM CARBIDE (Nonstoichiometric) NbC_x

[For Data Reported in Figure and Table No. 133]

Curve No.	Ref. No.	Year	Temp. Range, K	Reported Error, %	Name and Specimen Designation	Composition (weight percent), Specifications and Remarks
1	112	1960	300-1800		NbC _{0.50}	
2	112	1960	300-1800		NbC _{0.769}	
3	112	1960	300-1800		NbC _{0.847}	
4	184	1963	1289-2778	1.3	NbC _{0.87}	88.78 Nb, 11.10 C, <0.05 free C, 0.10 W, 0.06 Fe, and <0.05 Ta; hot pressed.

DATA TABLE NO. 133 SPECIFIC HEAT OF NIOBIUM CARBIDE (Nonstoichiometric) NbC_x[Temperature, T, K; Specific Heat, C_p, Cal g⁻¹ K⁻¹]

T	C _p	T	C _p
	<u>CURVE 1</u>		<u>CURVE 3 (cont.)</u>
300	7.330 x 10 ⁻²	800	1.073 x 10 ⁻¹
400	7.987	900	1.096
500	8.372	1000	1.120*
600	8.655	1100	1.141
700	8.877*	1200	1.162*
800	9.079*	1300	1.184
900	9.261	1400	1.204*
1000	9.443*	1500	1.224
1100	9.605	1600	1.245*
1200	9.777*	1700	1.264
1300	9.939	1800	1.284*
1400	1.010 x 10 ⁻¹ *		<u>CURVE 4</u>
1500	1.025	1289	1.230 x 10 ⁻¹
1600	1.041*	1383	1.240*
1700	1.057*	1487	1.250*
1800	1.073	1582	1.260
	<u>CURVE 2</u>	1675	1.270*
300	9.077 x 10 ⁻²	1789	1.290*
400	8.892	1887	1.300
500	9.392	1975	1.310*
600	9.765	2178	1.330
700	1.008 x 10 ⁻¹	2283	1.350*
800	1.036	2374	1.360
900	1.052	2482	1.370*
1000	1.087	2586	1.390
1160	1.111*	2682	1.400*
1200	1.135	2778	1.410
1300	1.159*		
1400	1.182		
1500	1.204*		
1600	1.228*		
1700	1.250*		
1800	1.273		
	<u>CURVE 3</u>		
300	8.363 x 10 ⁻²		
400	9.266		
500	9.789		
600	1.016 x 10 ⁻¹		
700	1.046		

*Not shown on plot

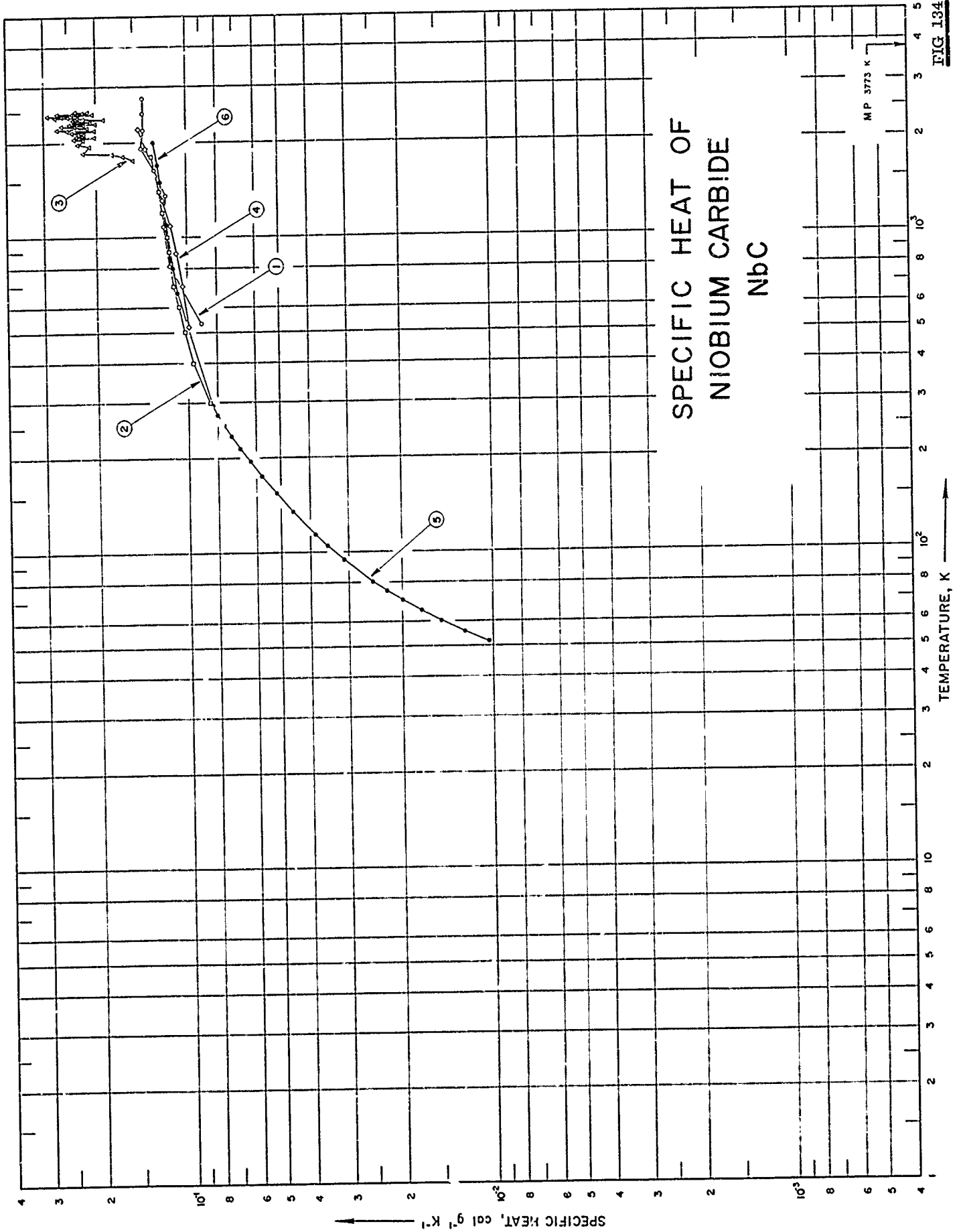

FIG 134

SPECIFICATION TABLE NO. 134 SPECIFIC HEAT OF NIOBIUM CARBIDE NbC

[For Data Reported in Figure and Table No. 134]

Curve No.	Ref. No.	Year	Temp. Range, K	Reported Error, %	Name and Specimen Designation	Composition (weight percent), Specifications and Remarks
1	32	1962	533-2755	±5		> 83.42 Nb, 11.3 C, 0.1 Fe, 0.10 W, 0.07 N, <0.01 Cr, Mg, Mn, Ni, Si, Sn, Ti, and Zr; sample supplied by Kennametal, Inc.; hot pressed; density 476 lb ft ⁻³ .
2	112	1960	300-1800			86.66 Nb, 16.91 total C.
3	173	1962	1763-2529	5		11.79 total C, 10.84 combine C, 0.94 free C; sprayed sample.
4	185	1962	522-2208			88.17 Nb, 11.74 total C, 11.35 combined C, <0.05 N ₂ , 0.03 O ₂ , 0.02 Ti, 0.006 Ag, and 0.002 Mn.
5	186	1964	51-296	0.1		Same as above.
6	186	1964	298-2000	0.1		Same as above.

DATA TABLE NO. 134 SPECIFIC HEAT OF NIOBIUM CARBIDE NbC
 [Temperature, T, K; Specific Heat, C_p , Cal $g^{-1} K^{-1}$]

T	C_p	T	C_p	T	C_p	T	C_p
<u>CURVE 1</u>							
533.15	9.000×10^{-2}	2068	2.340×10^{-1} *	2457	2.860×10^{-1} *	166.05	5.505×10^{-2} *
810.93	1.150×10^{-1}	2077	2.320*	2464	2.400	176.03	5.793
1088.71	1.200	2091	2.020	2471	2.060	185.95	6.059*
1366.48	1.180	2095	2.340	2475	2.280*	196.60	6.337
1644.26	1.280	2115	2.360*	2475	2.060*	206.09	6.581*
1922.04	1.420	2141	2.190	2477	2.090*	216.35	6.828
2199.82	1.400	2146	2.310*	2488	2.230	226.10	7.067*
2477.59	1.400	2154	2.100*	2494	2.330*	236.14	7.278
2755.37	1.400	2154	2.160*	2506	2.360*	245.85	7.478*
<u>CURVE 2</u>							
300	8.503×10^{-2}	2158	2.410	2507	2.210*	256.45	7.685
400	9.666	2193	2.030	2515	2.130	266.20	7.858*
500	1.029×10^{-1}	2199	2.450	2518	2.350	276.33	8.039
600	1.070	2206	2.700	2529	2.240*	286.60	8.211*
700	1.102	2237	2.140	2529	2.240*	296.11	8.368
800	1.128*	2263	2.240*	<u>CURVE 4</u>			
900	1.152	2265	2.360	522.59	9.927×10^{-2}	298.15	8.371×10^{-2} *
1000	1.172	2265	2.100*	704.82	1.040×10^{-1}	300	8.404*
1100	1.192*	2278	2.690	890.37	1.091	400	9.610*
1200	1.212	2286	2.590*	1090.93	1.146	500	1.024×10^{-1} *
1300	1.231*	2293	2.410*	1315.93	1.207	600	1.064*
1400	1.249	2298	2.450	1595.37	1.285*	670	1.086
1500	1.266*	2301	2.000	1923.15	1.375	700	1.097*
1600	1.284*	2308	1.990*	2208.15	1.454	800	1.105*
1700	1.301*	2339	2.360	<u>CURVE 5</u>			
1800	1.318	2342	2.330*	51.96	1.043×10^{-2}	900	1.128
<u>CURVE 3</u>							
1763	1.510 $\times 10^{-1}$	2345	2.080	55.88	1.248	900	1.147*
1817	1.630	2346	2.040*	60.33	1.487	1000	1.164*
1840	1.780	2351	1.990*	65.09	1.738	1100	1.179
1868	2.210	2360	2.360*	70.17	1.996	1200	1.194*
1952	2.100	2367	1.880	75.27	2.251	1300	1.207*
1961	2.080*	2376	2.200	80.75	2.505*	1400	1.221*
1970	2.300	2409	2.300	84.80	2.686	1500	1.233
1971	2.250*	2414	2.220*	94.71	3.104	1600	1.246*
1983	2.250*	2419	2.480	105.01	3.505	1700	1.258
2051	2.200	2421	2.660*	114.55	3.860	1800	1.270*
2053	2.370	2425	2.590	124.45	4.201*	1900	1.282*
<u>CURVE 6</u>							
		2451	2.900	135.76	4.576	2000	1.294
		2451	2.580*	145.81	4.901*		
		2453	2.680	155.67	5.199		

* Not shown on plot

FIG 135

SPECIFIC HEAT OF
PLUTONIUM CARBIDE
PuC

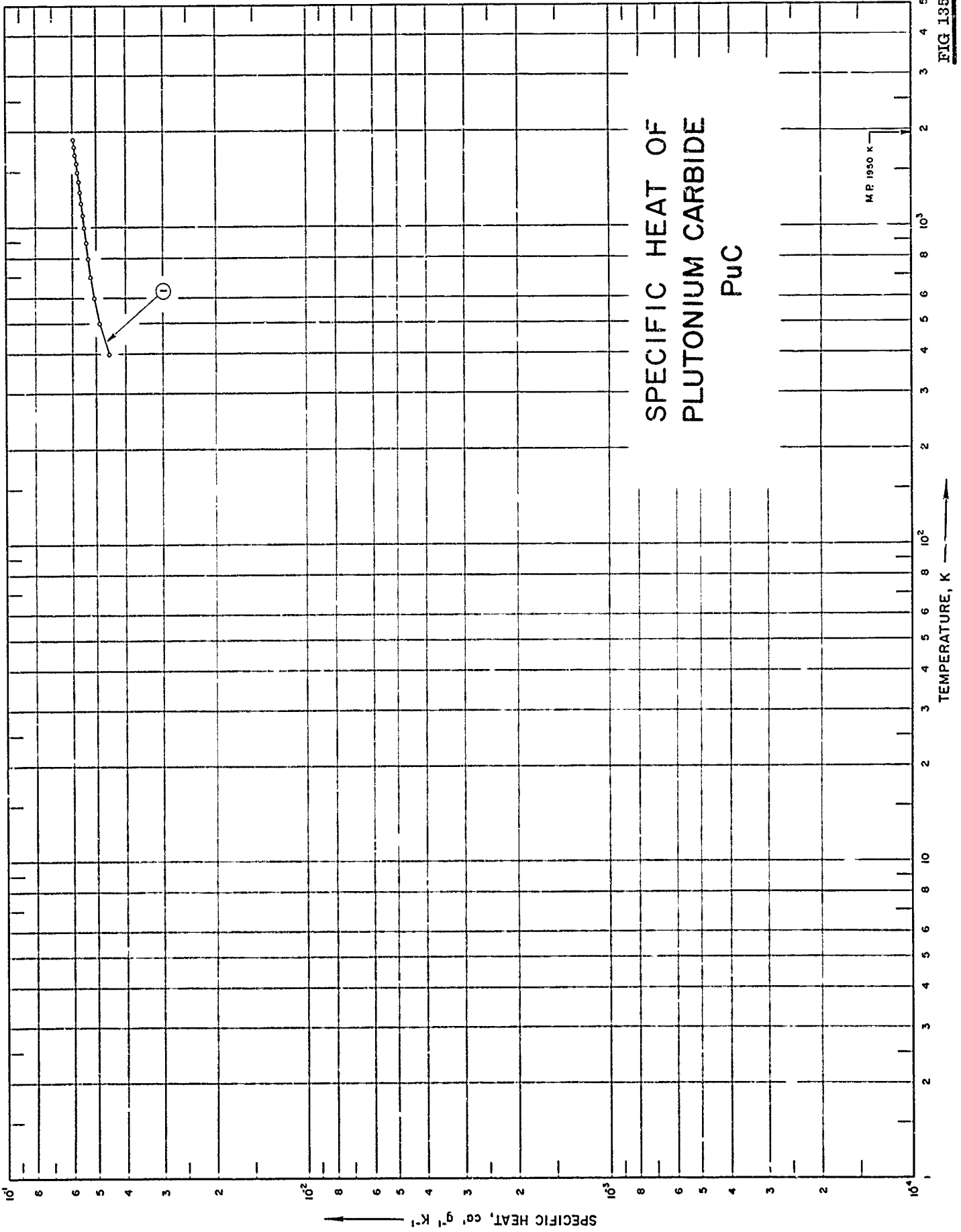

SPECIFICATION TABLE NO. 135 SPECIFIC HEAT OF PLUTONIUM CARBIDE PuC

[For Data Reported in Figure and Table No. 135]

Curve No.	Ref. No.	Year	Temp. Range, K	Reported Error, %	Name and Specimen Designation	Composition (weight percent), Specifications and Remarks
1	187	1963	400-1900			Single phase stoichiometric PuC.

DATA TABLE NO. 135 SPECIFIC HEAT OF PLUTONIUM CARBIDE PuC

[Temperature, T, K; Specific Heat, C_p , Cal g⁻¹K⁻¹]

T	C_p
<u>CURVE 1</u>	
400	4.535 x 10 ⁻²
500	4.866
600	5.059
700	5.205
800	5.311
900	5.398
1000	5.472
1100	5.539
1200	5.602
1300	5.661
1400	5.713
1500	5.772
1600	5.819
1700	5.874
1800	5.921
1900	5.969

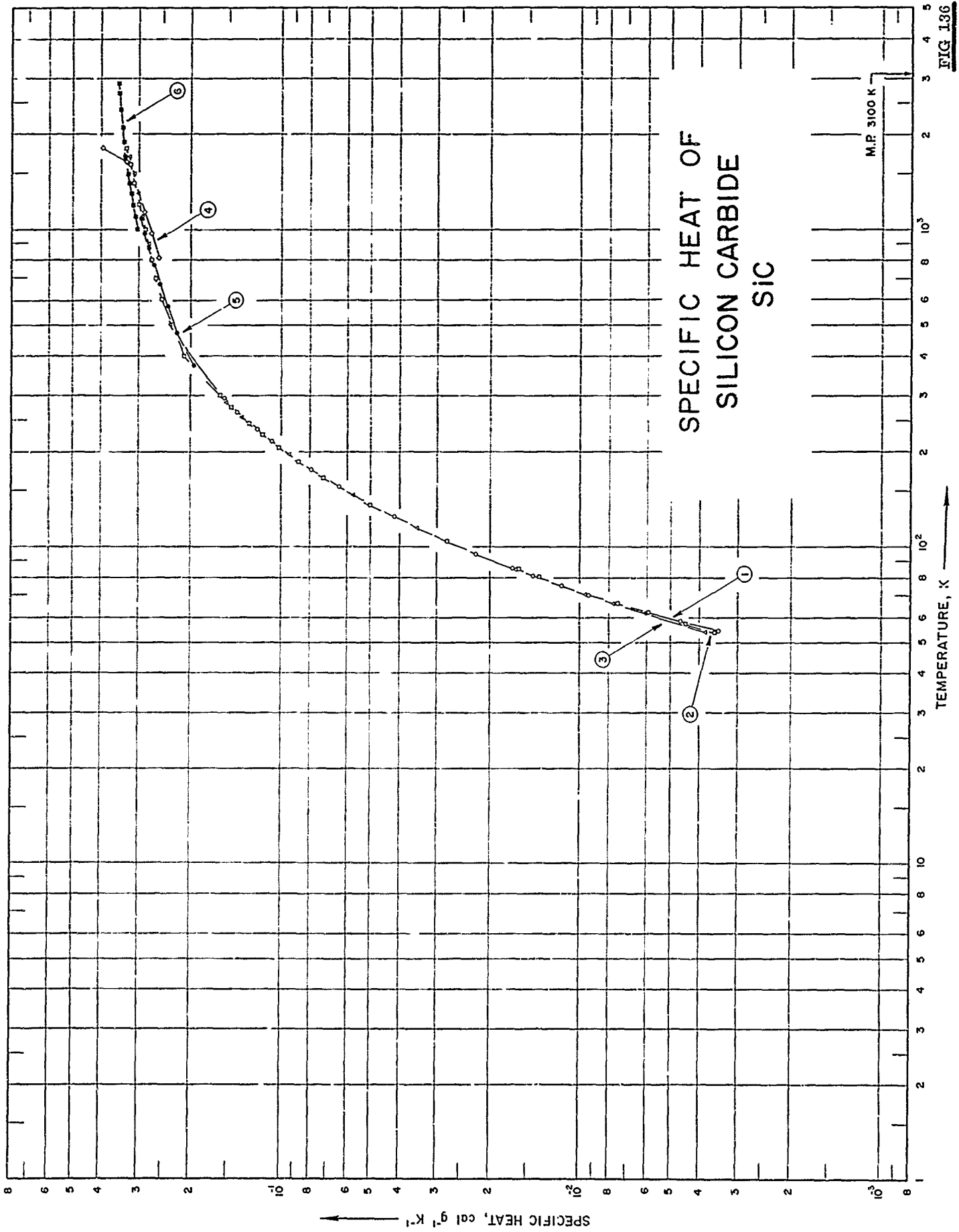

FIG 136

SPECIFICATION TABLE NO. 136 SPECIFIC HEAT OF SILICON CARBIDE SIC

[For Data Reported in Figure and Table No. 136]

Curve No.	Ref. No.	Year	Temp. Range, K	Reported Error, %	Name and Specimen Designation	Composition (weight percent), Specifications and Remarks
1	50	1941	54-294	0.5		99.0 SIC and 0.6 SiO ₂ ; corrected for SiO ₂ impurity.
2	188	1952	53-1800		hexagonal type II	99.73 SIC, 69.84 Si, 29.89 C, 0.18 Fe, 0.08 Al, and <0.01 Ca.
3	188	1952	53-1700		cubic	<1.0 hexagonal SIC, 0.34 free C, 0.17 SiO ₂ , 0.06 Al, 0.013 free Si, and 0.004 Fe.
4	189	1958	810-1310	3		As received: 67.46 Si, 28.58 C, 0.73 Al, 0.58 Fe, and 0.48 CaO, after test: 68.12 Si, 27.29 C, 1.47 Al, 0.44 CaO, and 0.32 Fe; density 193.4 lb ft ⁻³ .
5	45	1962	303-1073	<3		96.5 SIC, 2.5 Si, 0.4 C, and 0.4 Al.
6	190	1964	1000-2900	~2		87.07 SIC, 12.0 free C, 0.73 Fe; measured in an argon atmosphere; density 27.9 g cm ⁻³ .

DATA TABLE NO. 136 SPECIFIC HEAT OF SILICON CARBIDE SIC
 [Temperature, T, K; Specific Heat, C_p , Cal $g^{-1} K^{-1}$]

T	C_p	T	C_p	T	C_p	T	C_p
<u>CURVE 1</u>							
54.30	3.469×10^{-3}	136.16	5.006×10^{-2}	84.72	$1.641 \times 10^{-2*}$	1310.93	$3.010 \times 10^{-1*}$
58.20	4.642	146.11	5.740*	95.13	2.237*	1477.59	3.160*
62.10	5.940	155.86	6.454*	104.60	2.823*	1644.26	3.310
66.20	7.562*	166.15	7.230	114.73	3.521	1810.93	3.970
70.60	9.384	176.27	7.969*	124.64	4.208*	<u>CURVE 5</u>	
75.20	1.153×10^{-2}	186.21	8.707	135.82	5.011*	303.15	$1.63 \times 10^{-1*}$
80.70	1.430	196.13	9.426*	146.09	5.762	373.15	1.96
85.40	1.682	206.29	1.012×10^{-1}	155.89	6.481*	473.15	2.24
94.90	2.231	216.27	1.085*	166.01	7.240*	573.15	2.42
104.60	2.830*	226.18	1.153	175.89	7.974*	673.15	2.55
114.70	3.519*	236.01	1.217*	186.03	8.717*	773.15	2.67
124.70	4.220	245.80	1.283	195.90	9.433	873.15	2.77
135.10	4.974*	256.05	1.347*	206.08	$1.015 \times 10^{-1*}$	973.15	2.87
145.20	5.700*	266.22	1.409*	216.20	1.087*	1073.15	2.95
155.40	6.431	275.99	1.467	226.08	1.156*	<u>CURVE 6</u>	
165.70	7.195*	286.20	1.529*	236.12	1.223*	1000	3.033×10^{-1}
176.00	7.969	296.36	1.580*	245.86	1.290*	1100	3.098
185.60	8.652*	308.15	1.594*	256.27	1.353*	1200	3.152
195.40	9.379*	300.00	1.607	266.27	1.418*	1300	3.200
205.40	$1.008 \times 10^{-1*}$	400.00	2.699	276.14	1.477*	1400	3.241
215.60	1.081	500.00	2.352*	286.40	1.536	1500	3.274
225.90	1.153*	600.00	2.512	296.47	1.590*	1600	3.305*
235.80	1.218	700.00	2.627	298.17	1.602*	1700	3.332
245.60	1.283*	800.00	2.719	300.00	1.615*	1800	3.356*
255.70	1.346*	900.00	2.797*	300.00	2.102*	1900	3.377
265.70	1.402	1000.00	2.866	400.00	2.352	2000	3.396*
276.10	1.474*	1100.00	2.930*	500.00	2.508*	2100	3.413
284.80	1.518*	1200.00	2.990	600.00	2.621*	2200	3.430*
294.60	1.568	1300.00	3.047*	700.00	2.710*	2300	3.444*
<u>CURVE 2</u>							
53.57	3.564×10^{-3}	1400.00	3.102	800.00	2.785	2400	3.456
57.39	4.462*	1500.00	3.156*	900.00	2.852*	2500	3.468*
61.72	5.835*	1600.00	3.209	1000.00	2.913	2600	3.480*
66.25	7.477	1700.00	3.261*	1100.00	2.970*	2700	3.489
70.85	9.326*	1800.00	3.312	1200.00	3.025	2800	3.499*
75.55	$1.140 \times 10^{-2*}$	<u>CURVE 3</u>		1300.00	3.078*	2900	3.509
80.46	1.378	53.91	3.838×10^{-3}	1400.00	3.122	<u>CURVE 4</u>	
84.98	1.614	57.58	4.684*	1500.00	3.175*	810.93	2.560×10^{-1}
95.07	2.187*	61.88	6.079	1600.00	3.229	977.59	2.710
104.54	2.785	66.41	7.791	1700.00	3.289	1144.26	2.860
114.73	3.481*	70.93	9.618	1800.00	3.342	<u>CURVE 5</u>	
124.76	4.170*	75.51	$1.160 \times 10^{-2*}$	1900.00	3.396*	810.93	2.560×10^{-1}
		80.35	1.407	2000.00	3.450*	977.59	2.710
				2100.00	3.504*	1144.26	2.860

*Not shown on plot

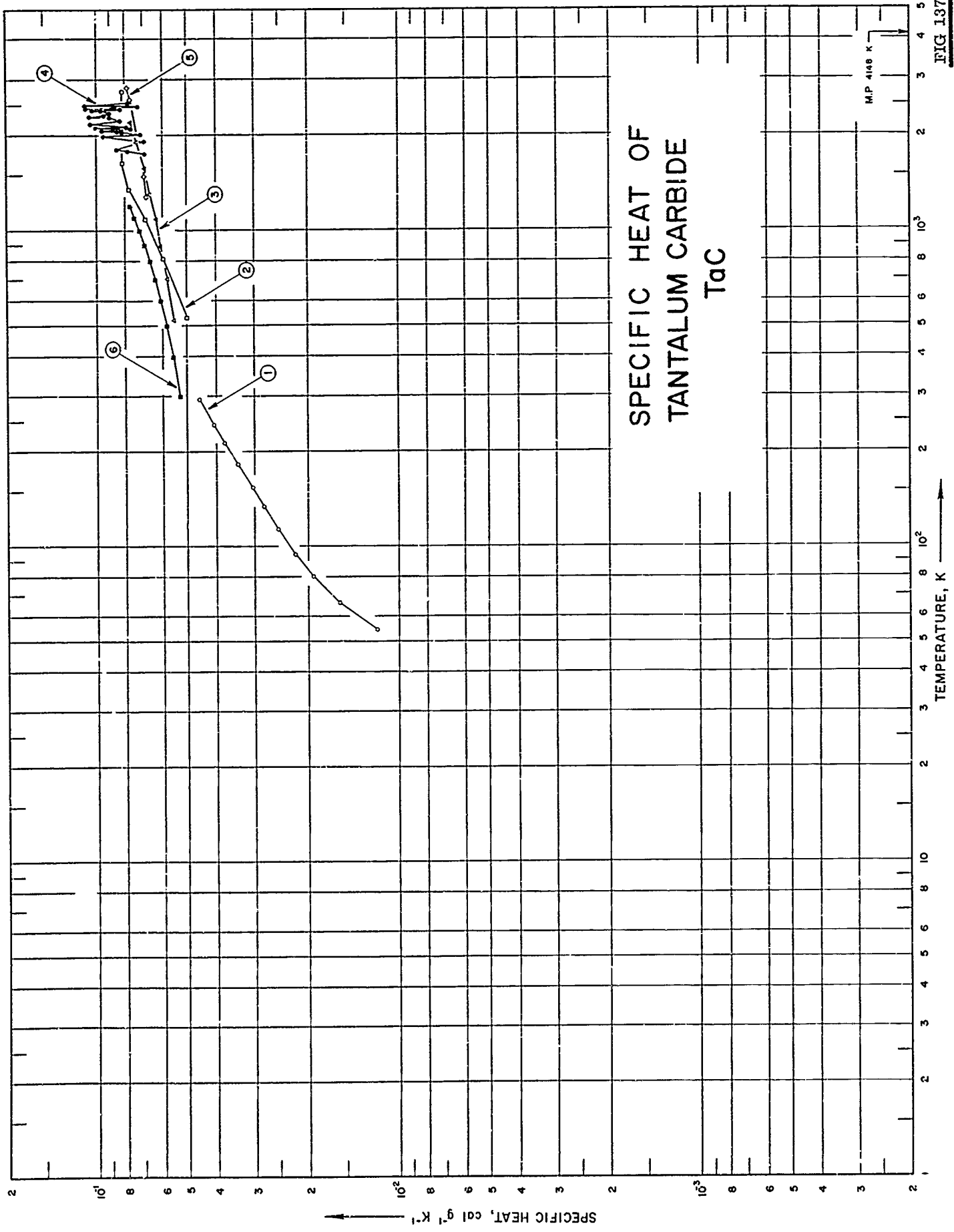

FIG 137 451

SPECIFICATION TABLE NO. 137 SPECIFIC HEAT OF TANTALUM CARBIDE TaC

[For Data Reported in Figure and Table No. 137]

Curve No.	Ref. No.	Year	Temp. Range, K	Reported Error, %	Name and Specimen Designation	Composition (weight percent), Specifications and Remarks
1	127	1940	54-294			99.95 TaC, 0.03 excess C, 0.02 other impurities.
2	32	1962	533-2755	±5		>93.75 Ta, 6.14 C, 0.10 W, <0.01 Al, Ca, Nb, Fe, Mg, Na, Ni, Si, Sn, Ti, and Zr; sample supplied by Kennametal, Inc.; hot pressed; density 476 lb ft ⁻³ .
3	185	1962	523-2214			Bal. Ta, 6.29 total C, 6.24 combined C, and 0.019 free C; sprayed sample.
4	173	1962	1763-2544	5		90.48 Ta, 6.27 total C, 0.04 free C, 1.62 Nb, 0.9 Ti, 0.22 Hf, 0.20 Fe, 0.18 O, 0.17 Zr, 0.09 N, 0.07 Mn, <0.01 Cr, Cu, and Ni; hot pressed at 1350 C and 2000 psi for 1 hr; density 82.2 lb ft ⁻³ (theoretically: density 90.4 lb ft ⁻³).
5	184	1963	1296-2843	1.8		92.14 Ta, 6.21 C, 0.80 W, 0.50 Nb, 0.20 Fe, and <0.05 free C.
6	54	1965	300-1200	0.7		Traces of Ca, Cu, and Si; sample supplied by the Carborundum Co.

DATA TABLE NO. 137 SPECIFIC HEAT OF TANTALUM CARBIDE TaC

[Temperature, T, K; Specific Heat, C_p , Cal g⁻¹ K⁻¹]

T	C_p	T	C_p	T	C_p
<u>CURVE 1</u>					
54.60	1.179 x 10 ⁻²	523.15	5.526 x 10 ⁻²	2448	1.086 x 10 ⁻¹
58.10	1.299*	706.48	5.855	2455	1.080*
62.10	1.430*	893.71	6.126	2460	8.580 x 10 ⁻² *
66.50	1.572	1090.37	6.383	2460	9.720*
71.10	1.710*	1315.93	6.663	2465	1.065 x 10 ⁻¹ *
75.60	1.827*	1585.37	6.987	2472	7.280 x 10 ⁻²
80.30	1.936	1904.26	7.365	2474	1.090 x 10 ⁻¹
80.60	1.945*	2214.26	7.730	2474	9.580 x 10 ⁻² *
84.40	2.023*	<u>CURVE 4</u>			
84.90	2.034*	1763	6.910 x 10 ⁻²	2507	8.780*
94.50	2.214	1780	7.860	2544	7.820
104.30	2.376*	1789	8.000*	<u>CURVE 5</u>	
114.70	2.528	1804	8.550	1296	6.830 x 10 ⁻²
124.80	2.669*	1939	6.930	1401	6.910*
134.80	2.807	1997	9.450	1488	6.970*
144.80	2.935*	2023	7.100	1491	6.970
154.50	3.059	2052	8.220	1606	7.050*
164.60	3.184*	2058	7.930*	1703	7.110*
174.20	3.306*	2078	8.570	1809	7.190*
184.50	3.429	2115	9.530	1919	7.260*
194.30	3.548*	2125	7.680	1930	7.270*
204.50	3.669*	2188	1.011 x 10 ⁻¹	2065	7.360*
214.60	3.780	2234	7.910 x 10 ⁻²	2209	7.460*
224.50	3.895*	2234	1.054 x 10 ⁻¹	2318	7.540*
234.50	3.999*	2258	8.330 x 10 ⁻²	2426	7.610*
244.70	4.102	2291	8.240*	2535	7.690*
255.10	4.204*	2297	9.050	2628	7.750
265.30	4.293*	2309	1.065 x 10 ⁻¹	2642	7.760*
275.10	4.367*	2316	1.070*	2746	7.830
284.60	4.437*	2321	9.460 x 10 ⁻²	2843	7.900
293.90	4.532*	2349	8.880*	<u>CURVE 6</u>	
294.50	4.544	2360	9.080	300	5.312 x 10 ⁻²
<u>CURVE 2</u>					
533.15	5.00 x 10 ⁻²	2379	8.920*	400	5.582
810.93	6.00	2396	9.350*	500	5.851
1088.71	6.90	2401	9.660	600	6.126
1366.48	7.80	2406	8.450*	700	6.396
1644.26	8.20	2408	1.027 x 10 ⁻¹	800	6.665
1922.04	8.20*	2426	8.310 x 10 ⁻²	900	6.935
2199.82	8.20*	2433	9.170*	1000	7.204
2477.59	8.20*	2448	8.370*	1100	7.499
2755.37	8.20	<u>CURVE 3</u>			
<u>CURVE 4 (cont.)</u>					

*Not shown on plot

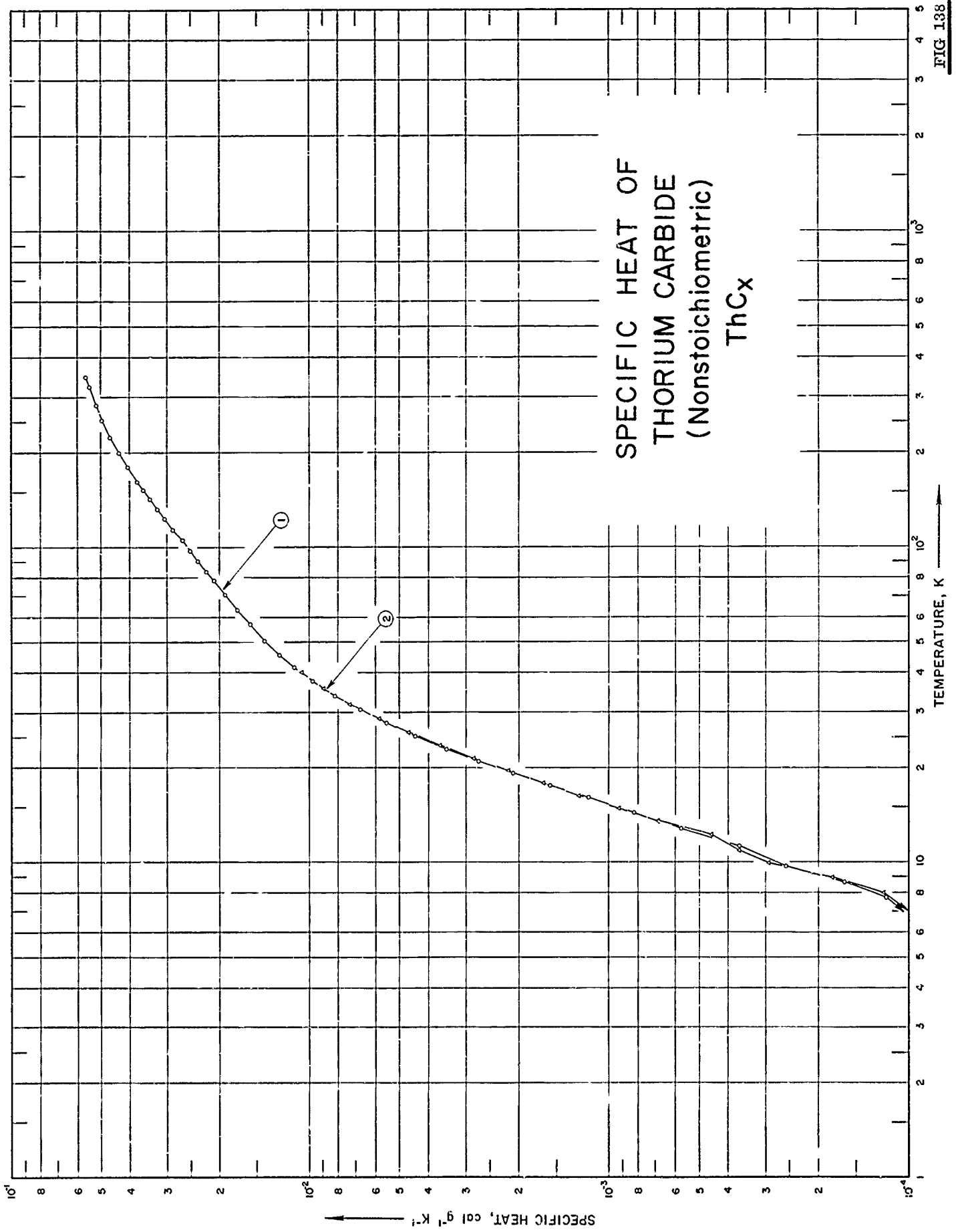

SPECIFICATION TABLE NO. 138 SPECIFIC HEAT OF THORIUM CARBIDE (Nonstoichiometric) ThCx

[For Data Reported in Figure and Table No. 138]

Curve No.	Ref. No.	Year	Temp. Range, K	Reported Error, %	Name and Specimen Designation	Composition (weight percent), Specifications and Remarks
1	191	1965	6-346	0.1	ThC _{1.93} , hypostoichiometric Thorium Dicarbide	8.99 C, 1.758 W, 0.0575 O, 0.00268 N, 0.00228 H; turned and melted several times, crushed to powder, and remelted several more times.
2	192	1965	6-345		ThC ₂	99.21 ThC ₂ , 0.79 free C; prepared from thorium powder and graphite; pressed at 700 Kg cm ⁻² into 0.8 cm dia pellets and heated for 30 min under vacuum at 2100 C; pellets were crushed and ground, heated for 5 hrs at 2000 C, then reground and reheated for 5 hrs at 2000 C to homogenize the sample.

DATA TABLE NO. 138 SPECIFIC HEAT OF THORIUM CARBIDE (Nonstoichiometric) ThC_x[Temperature, T, K; Specific Heat, C_p, Cal g⁻¹ K⁻¹]

T	C _p	T	C _p	T	C _p	T	C _p
CURVE 1		CURVE 1 (cont.)		CURVE 2 (cont.)		CURVE 2 (cont.)	
Series 1		Series 3*		Series 2*		Series 5*	
83.82	2.203 x 10 ⁻²	61.78	1.699 x 10 ^{-2*}	83.21	2.198 x 10 ⁻²	134.25	3.276 x 10 ⁻²
90.61	2.352	68.00	1.848*	90.97	2.378	143.16	3.457
97.88	2.504	74.52	1.990*	99.82	2.552	152.77	3.632
105.62	2.668	81.68	2.158*	109.60	2.760	162.86	3.815
114.54	2.858	89.80	2.338	119.31	2.967	166.97	3.896
123.70	3.052	Series 4*		128.96	3.168	176.77	4.044
132.92	3.241	74.30	1.986 x 10 ⁻²	Series 3		186.89	4.196
142.48	3.430	81.54	2.153	5.98	7.420 x 10 ^{-6*}	197.06	4.335
152.03	3.609	89.74	2.338	6.87	9.763*	207.30	4.473
161.56	3.778	Series 5		7.99	1.211 x 10 ⁻⁴	217.76	4.593
170.92	3.933*	195.71	4.303 x 10 ^{-2*}	8.96	1.796	228.44	4.713
180.32	4.079	214.69	4.537*	9.92	2.929	239.29	4.827
189.96	4.218*	235.11	4.424*	10.96	3.671	250.09	4.926
199.53	4.347	244.40	4.650	12.21	4.567	260.59	5.014
Series 2		234.14	4.754*	13.51	6.834	270.79	5.098
6.09	5.871 x 10 ^{-6*}	243.88	4.853*	14.84	9.295	289.65	5.251
6.87	1.018 x 10 ^{-4*}	253.82	4.938	16.34	1.261 x 10 ⁻³	299.21	5.318
7.72	1.056	263.25	5.025*	17.94	1.660	308.55	5.374
8.65	1.644	273.07	5.109*	19.60	2.160	317.82	5.427
9.73	2.583	282.82	5.186	21.42	2.827	327.01	5.480
11.28	3.679	292.57	5.265*	23.52	3.659	336.12	5.558
12.87	5.754	302.30	5.347*	25.94	4.679	345.16	5.613
14.40	8.270	311.90	5.399*	28.64	5.889		
16.02	1.178 x 10 ⁻³	321.38	5.461	31.81	7.315		
17.56	1.581	330.76	5.515*	35.70	8.928		
19.19	2.090	339.13	5.569*	40.18	1.060 x 10 ⁻²		
20.99	2.724	346.38	5.604	45.34	1.229*		
22.97	3.492	CURVE 2		Series 4*			
25.18	4.415	40.63	1.081 x 10 ⁻²				
27.72	5.511	45.40	1.233				
30.60	6.772	50.27	1.376				
33.84	8.193	55.91	1.527				
37.73	9.786	62.42	1.702				
41.77	1.123 x 10 ⁻²	69.70	1.873				
45.78	1.257	77.63	2.055				
50.71	1.407						
57.00	1.575						
63.61	1.744						
70.86	1.909						
78.76	2.086						

* Not shown on plot

FIG 139

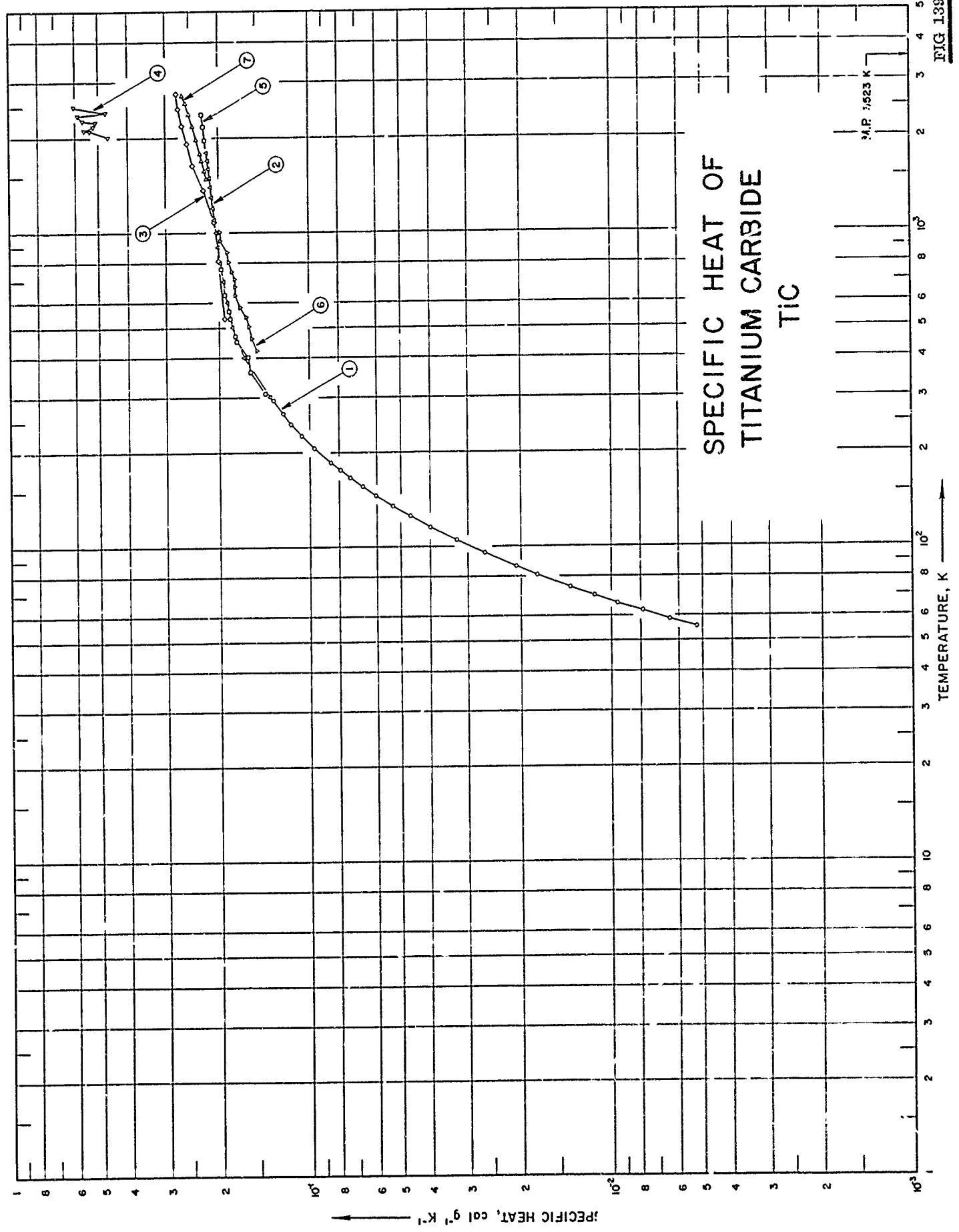

SPECIFICATION TABLE NO. 1000 SPECIFIC HEAT OF TITANIUM CARBIDE TIC

[For Data Reported in Figure and Table No. 139]

Curve No.	Ref. No.	Year	Temp. Range, K	Reported Error, %	Name and Specimen Designation	Composition (weight percent), Specifications and Remarks
1	193	1944	55-294			96.08 TIC, 1.82 TiO ₂ , and 0.06 unaccounted; data corrected for impurities.
2	194	1946	298-1600			99.0 TIC, 0.4 unreacted Ti (theo. 29.56 Ti and 19.85 C); prepared by heating powdered Ti with 99.7 pure C in a vacuum at 1300 C; density 300 lb ft ⁻³ .
3	48	1962	533-2755	±5		Before exposure: 79.8 Ti, 19.2 C, 0.9 N, 0.6 Fe, and 0.5 Zr, after exposure: 79.2 Ti, 19.0 C, 0.6 N; sample supplied by the Carborundum Co; hot pressed; crushed in hardened steel mortar to pass 100-mesh screen; density at 25 C, before exposure: apparent density (ASTM method E311-58) 295 lb ft ⁻³ , true density (by immersion in xylene) 298 lb ft ⁻³ , after exposure: apparent density 292 lb ft ⁻³ , true density 300 lb ft ⁻³ .
4	173	1962	2023-2121	5		77.41 Ti, 17.78 total C, 0.43 free C, 0.50 free Ti, 0.56 Zr, 0.12 Fe, <0.1 Al, Hf, 0.09 Nb, 0.004 Cu, and <0.001 Mg; solid pieces machined to specification using diamond tool and electric discharge technique.
5	195	1963	298-2372			80.3 ± 0.3 Ti, 19.3 C, <0.2 metallic impurities; sample supplied by the Carborundum Co; density 298 lb ft ⁻³ .
6	195	1963	423-1005	±5		79.2 Ti, 20.2 C, <0.2 metallic impurities; sample supplied by the Norton Co; density 296 lb ft ⁻³ .
7	196	1965	1274-2722	1.4		79.42 Ti, 18.82 combined C, 0.71 free C, <0.1 W, and 0.04 O ₂ ; lattice parameter a ₀ = 4.327 ± 0.0002 Å; hot pressed in graphite dies and then electrospark machined.

DATA TABLE NO. 139 SPECIFIC HEAT OF TITANIUM CARBIDE TIC
 [Temperature, T, K; Specific Heat, C_p, Cal g⁻¹ K⁻¹]

T	C _p	T	C _p	T	C _p	T	C _p		
<u>CURVE 1</u>									
55.1	5.208 x 10 ⁻³	1400	2.131	Series 2					
58.6	6.410	1500	2.148	CURVE 5 (cont.)					
62.3	7.895	1600	2.165	309.15	1.400 x 10 ⁻¹	732.15	1.790 x 10 ^{-1*}		
65.9	9.531	1700	2.181	361.15	1.570	751.15	1.810		
71.2	1.145 x 10 ⁻²	1800	2.197	451.15	1.750	771.15	1.830*		
74.2	1.370	<u>CURVE 3</u>						809.15	1.860
86.5	2.073	CURVE 2 (cont.)						829.15	1.870*
95.7	2.649	CURVE 4						849.15	1.870*
105.3	3.272	2023	4.670 x 10 ⁻¹	853.15	1.930 x 10 ⁻¹	868.15	1.880		
115.6	3.988	2113	5.350	887.15	1.860*	888.15	1.900*		
125.7	4.655	2186	5.200	898.15	1.880*	908.15	1.930*		
135.6	5.325	2279	5.640	891.15	1.940*	927.15	1.970*		
146.0	6.019	2353	5.890	801.15	1.990*	946.15	1.990		
156.2	6.693	2449	6.040*	816.15	1.990*	965.15	2.000*		
166.5	7.348	2506	6.020	Series 3				985.15	2.000*
176.2	7.929	2412	4760	1573.15	2.160 x 10 ^{-1*}	1005.15	1.990		
186.3	8.534*	2252	5.100	1673.15	2.180*	<u>CURVE 7</u>			
196.8	9.137*	2121	5.590	1773.15	2.190*	1274	2.11 x 10 ^{-1*}		
206.5	9.644	CURVE 5						1389	2.16*
216.8	1.018 x 10 ^{-1*}	Series 1						1481	2.19
226.3	1.065	298.15	1.342 x 10 ^{-1*}	1973.15	2.220	1576	2.22		
236.0	1.108*	300	1.351	2073.15	2.240*	1696	2.27		
246.2	1.156*	400	1.655	2173.15	2.250	1775	2.29*		
256.0	1.196*	500	1.889	2273.15	2.270*	1890	2.34*		
266.1	1.239	600	1.802	2373.15	2.280	1987	2.37		
276.3	1.277*	700	1.946	CURVE 6				2075	2.40*
285.7	1.307*	800	1.988	423.15	1.490 x 10 ⁻¹	2184	2.44		
294.9	1.333	900	2.021	442.15	1.530*	2274	2.48*		
<u>CURVE 2</u>									
298.15	1.342 x 10 ^{-1*}	1000	2.048	462.15	1.560	2377	2.51		
300	1.351	1100	2.072	482.15	1.580*	2473	2.55*		
400	1.655	1200	2.093	501.15	1.590	2569	2.58		
500	1.889	1300	2.113	521.15	1.610*	2674	2.62*		
700	1.946	CURVE 5						2722	2.64
800	1.988	Series 1							
900	2.021	298.15	1.340 x 10 ^{-1*}	40.15	1.630				
1000	2.048	565.15	1.860	559.15	1.660*				
1100	2.072	637.15	1.910	579.15	1.700				
1200	2.093	768.15	1.970	598.15	1.730*				
1300	2.113	470.15	1.770	617.15	1.760*				
		403.15	1.600	635.15	1.770				
				654.15	1.770*				
				673.15	1.770				
				693.15	1.770*				
				712.15	1.770				

* Not shown on plot

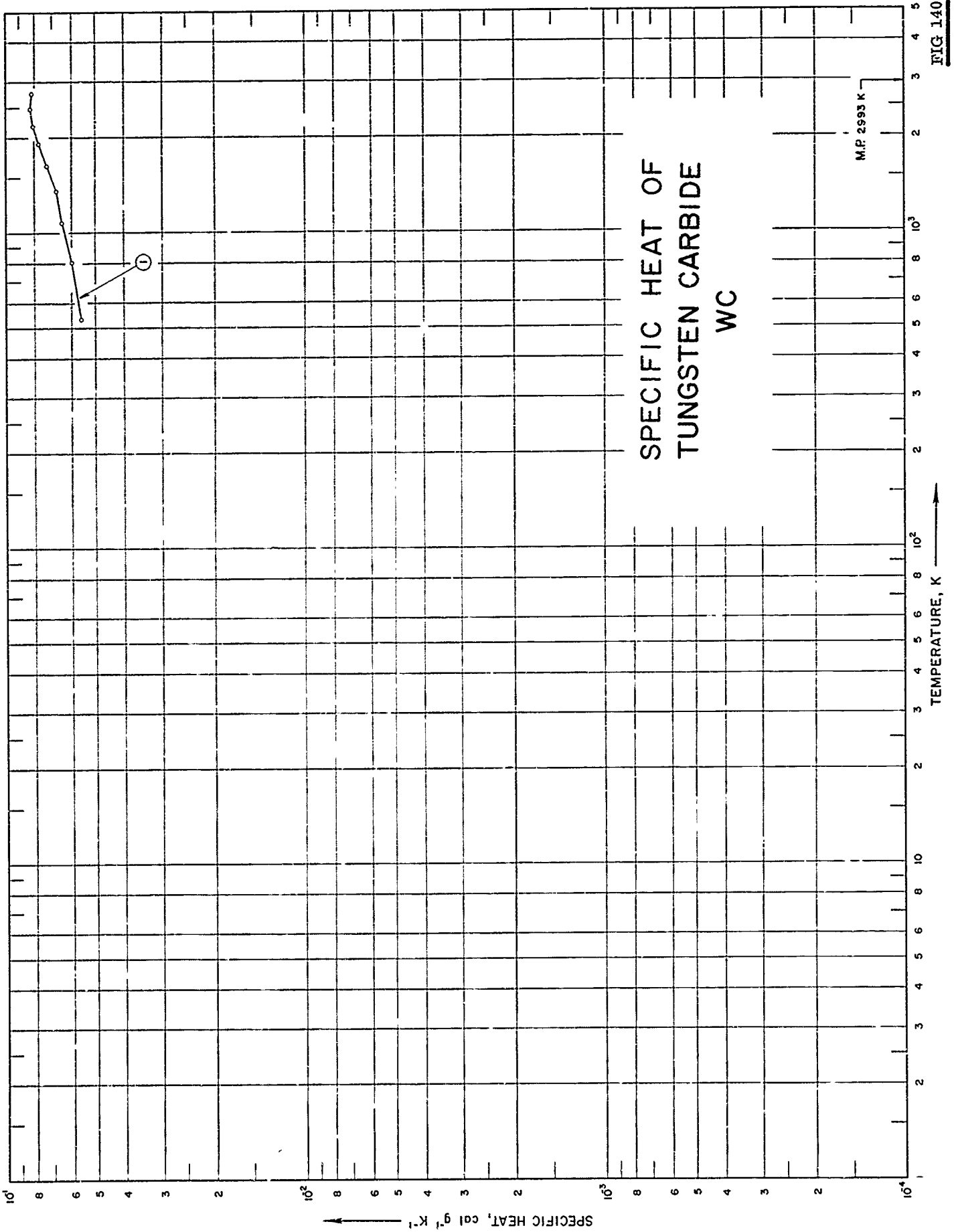

FIG. 140

SPECIFICATION TABLE NO. 140 SPECIFIC HEAT OF TUNGSTEN CARBIDE WC

[For Data Reported in Figure and Table No. 140]

Curve No.	Ref. No.	Year	Temp. Range, K	Reported Error, %	Name and Specimen Designation	Composition (weight percent), Specifications and Remarks
1	48	1962	533-2755	±5		Before exposure: 93.9 W, 6.15 C, 0.4 Fe, 0.3 Si, and <0.1 N, after exposure: 94.1 W, 5.95 C, and <0.1 N; sample supplied by the Carborundum Co; hot pressed; crushed in a hardened steel mortar to pass 100-mesh screen; density 25 C, before exposure: apparent density (ASTM method B311-58) 935 lb ft ⁻³ , true density (by immersion in xylene) 942 lb ft ⁻³ , after exposure: apparent density 818 lb ft ⁻³ , true density 918 lb ft ⁻³ .

DATA TABLE NO. 140 SPECIFIC HEAT OF TUNGSTEN CARBIDE WC
[Temperature, T, K; Specific Heat, C_p , Cal $g^{-1} K^{-1}$]

T	C_p
<u>CURVE 1</u>	
533.15	5.600 x 10 ⁻²
810.93	6.000
1088.71	6.500
1366.48	6.800
1644.26	7.300
1922.04	7.800
2199.82	8.100
2477.59	8.300
2755.37	8.200

SPECIFIC HEAT OF URANIUM CARBIDE UC

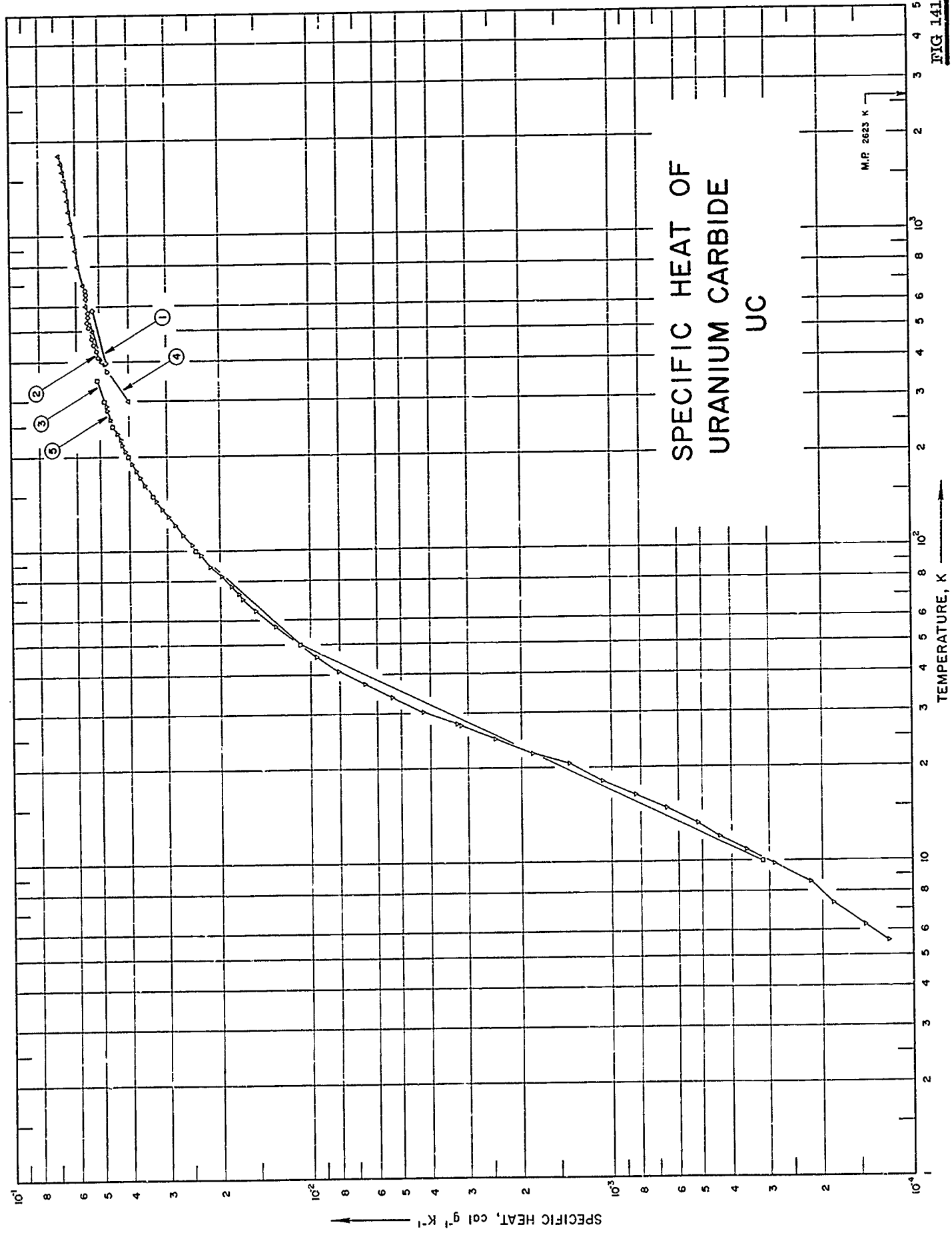

FIG. 141

SPECIFICATION TABLE NO. 141 SPECIFIC HEAT OF URANIUM CARBIDE UC

[For Data Reported in Figure and Table No. 141]

Curve No.	Ref. No.	Year	Temp. Range, K	Reported Error, %	Name and Specimen Designation	Composition (weight percent), Specifications and Remarks
1	197	1958	398, 523			~95.185 U, 4.815 total C, 0.054 free C.
2	198	1962	373-673	3.0		99.93 U, 0.044 C, 0.00601 Fe, 0.004 Si, 0.0032 N, 0.0018 Mg, and 0.00172 Al; this is the composition of U from which UH_3 was prepared; prepared by solid-phase reaction of uranium hydride and carbon at 1100 C for 2 hrs in 10^{-5} mm Hg vacuum.
3	199	1962	10-350			Average composition, 94.18 U, 5.134 C; measured in a helium atmosphere.
4	200	1964	300-1800	±4		95.12 U, 4.88 C, 0.0135 O, and 0.006 N.
5	201	1965	5-345	0.1-5		94.16 U, 5.01 total C, 0.07 free C.

DATA TABLE NO. 141 SPECIFIC HEAT OF URANIUM CARBIDE UC

[Temperature, T, K; Specific Heat, Cp, Cal g⁻¹ K⁻¹]

T	Cp	T	Cp	T	Cp
	<u>CURVE 1</u>		<u>CURVE 4 (cont.)</u>		<u>CURVE 5 (cont.)</u>
398	4.800 x 10 ⁻²	1000	6.1537 x 10 ⁻²		Series 2
523	5.300	1100	6.2453	5.59	1.200 x 10 ⁻⁴
	<u>CURVE 2</u>	1200	6.3301	6.29	1.440
373.15	4.780 x 10 ⁻²	1300	6.4097	7.34	1.839
393.15	4.900*	1400	6.486	8.58	2.199
413.15	5.070	1500	6.5594	9.80	2.879
433.15	5.110	1600	6.632	10.96	3.559
453.15	5.220	1700	6.702	12.01	4.359
473.15	5.300	1800	6.822	13.33	5.198
493.15	5.410*		<u>CURVE 5</u>	14.81	6.598
513.15	5.420		Series 1	16.34	8.317
533.15	5.500	70.77	1.683 x 10 ⁻²	18.09	1.076 x 10 ⁻³
553.15	5.490	77.22	1.845	20.06	1.396
573.15	5.490	83.05	1.999	22.23	1.843
593.15	5.520*	89.76	2.158	24.66	2.451
613.15	5.530*	97.21	2.323	27.26	3.199
633.15	5.560	105.51	2.499		Series 3
653.15	5.560	113.99	2.677	27.51	3.279 x 10 ⁻³
673.15	5.590	121.79	2.831	30.45	4.219
	<u>CURVE 3</u>	129.42	2.989	33.82	5.382
10	3.153 x 10 ⁻⁴	136.94	3.125	37.43	6.662
50	1.094 x 10 ⁻²	145.20	3.259	41.57	8.089
100	2.413	154.43	3.418*	45.76	9.505
150	3.353	163.09	3.554	50.67	1.107 x 10 ^{-2*}
200	4.031	171.92	3.685	57.26	1.308
250	4.507	180.90	3.801	64.66	1.520
300	4.858	190.31	3.919	73.02	1.739
350	5.102	199.76	4.033*	297.50	4.815*
298.15	4.383*	209.05	4.124	307.09	4.892*
	<u>CURVE 4</u>	218.35	4.219	316.82	4.950*
300	4.0478 x 10 ⁻²	227.82	4.286	326.76	5.003*
400	4.91	237.23	4.401	336.63	5.052*
500	5.344	246.47	4.478*	345.99	5.074*
600	5.6096	255.52	4.549*		
700	5.7936	264.39	4.610		
800	5.9355	273.24	4.686*		
900	6.0525	282.25	4.742		
		291.11	4.796		
		300.00	4.872*		

*Not shown on plot

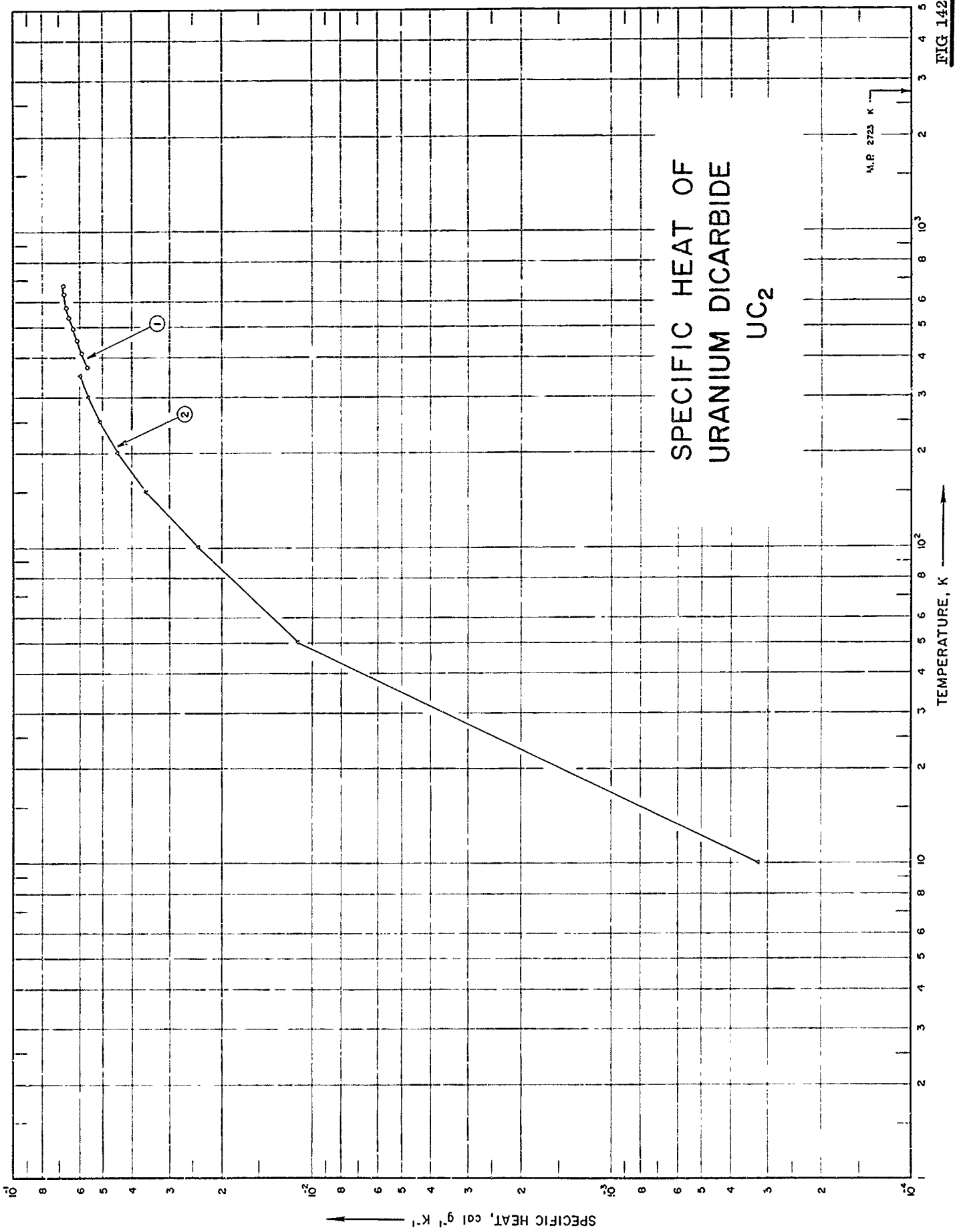

FIG 142

SPECIFICATION TABLE NO. 142 SPECIFIC HEAT OF URANIUM DICARBIDE UC_2

[For Data Reported in Figure and Table No. 142]

Curve No.	Rel. No.	Year	Temp. Range, K	Reported Error, %	Name and Specimen Designation	Composition (weight percent), Specifications and Remarks
1	198	1962	373-673	3.0		99.93 U, 0.044 C, 0.00601 Fe, 0.004 Si, 0.0032 N, 0.0018 Mg, and 0.00172 Al; this is the composition of U from which UH_3 was prepared; prepared by two-step solid-phase reaction of stoichiometric mixture of UH_3 and C at 1100 C for 2 hrs under vacuum; reheated at 1700 C for 2 hrs.
2	199	1962	10-350			90.79 U, 9.20 C, measured in a helium atmosphere.

DATA TABLE NO. 142 SPECIFIC HEAT OF URANIUM DICARBIDE UC₂[Temperature, T, K; Specific Heat, C_p, Cal g⁻¹ K⁻¹]

T	C _p
<u>CURVE 1</u>	
373.15	5.650 x 10 ⁻²
393.15	5.750*
413.15	5.910
433.15	5.990*
453.15	6.110
473.15	6.180 ⁻¹
493.15	6.310
513.15	6.420*
533.15	6.500
553.15	6.550*
573.15	6.610
593.15	6.690*
613.15	6.720*
633.15	6.730
653.15	6.740*
673.15	6.740
<u>CURVE 2</u>	
10	3.243 x 10 ⁻⁴
50	1.119 x 10 ⁻²
100	2.430
150	3.594
200	4.487
250	5.113
300	5.613
350	5.964
298.15	5.590*

* Not shown on plot

FIG 148

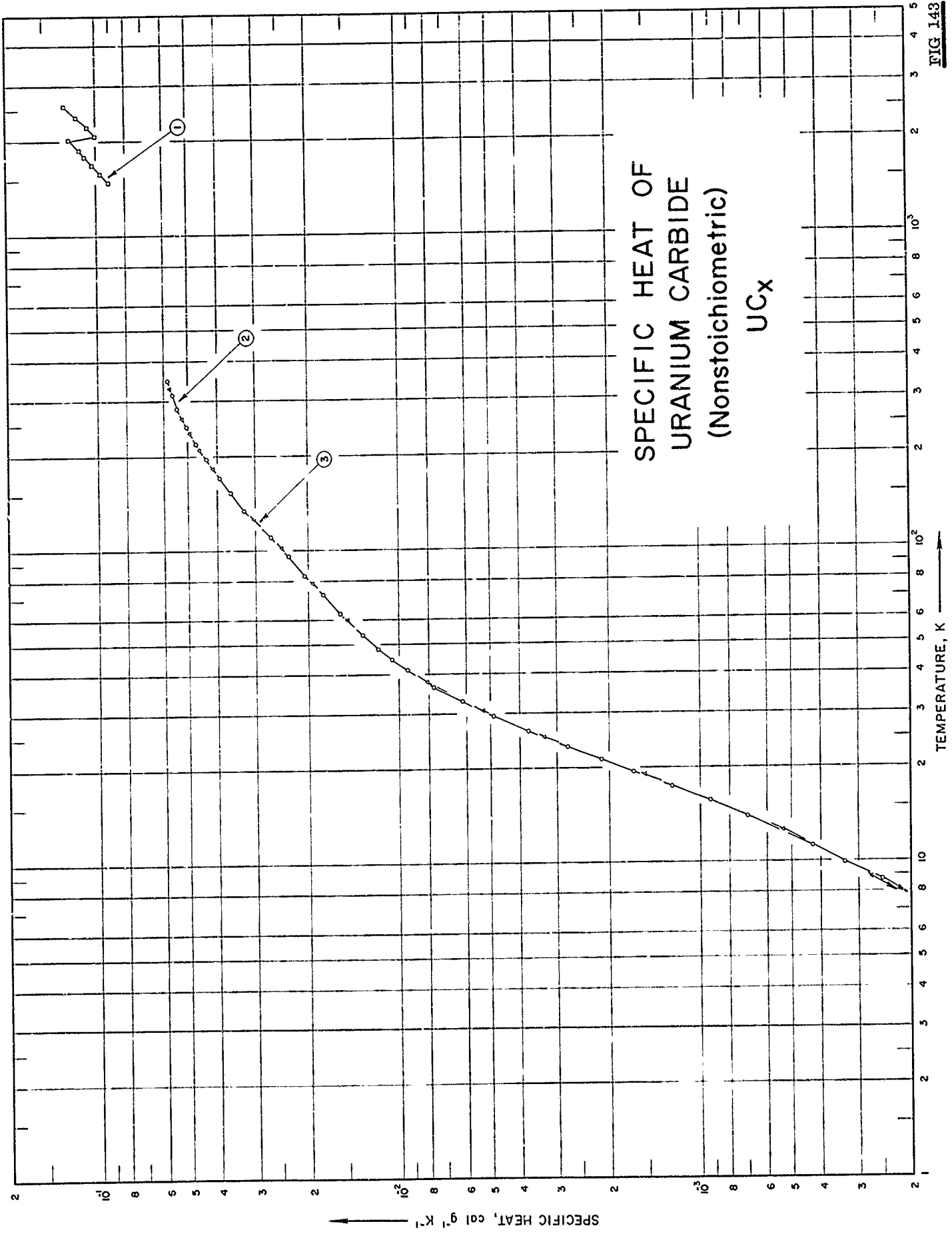

SPECIFICATION TABLE NO. 143 SPECIFIC HEAT OF URANIUM CARBIDE (Nonstoichiometric) UC_x

[For Data Reported in Figure and Table No. 143]

Curve No.	Ref. No.	Year	Temp. Range, K	Reported Error, %	Name and Specimen Designation	Composition (weight percent), Specifications and Remarks
1	202	1963	1484-2581	2	$UC_{1.33}$	90.88 U, 8.9 total C, 0.13 free C, ar. 0.22 O_2 .
2	201	1965	5-346	0.1-5	$UC_{1.9}$	90.79 U, 9.20 total C, and 1.0 free C.
3	203	1965	6-345	0.1-5	$UC_{1.34}$	91.18 \pm 0.07 U, 8.91 \pm 0.03 C, 0.0035 \pm 0.0005 O_2 , and <0.05 free C.

DATA TABLE NO. 143 SPECIFIC HEAT OF URANIUM CARBIDE (Nonstoichiometric) UC_x[Temperature, T, K; Specific Heat, C_p, Cal g⁻¹ K⁻¹]

T	C _p	T	C _p	T	C _p	T	C _p
CURVE 1		CURVE 2 (cont.)		CURVE 2 (cont.)		CURVE 3 (cont.)	
1484	9.1 x 10 ⁻²	Series 2		Series 4 (cont.)		Series 3 (cont.)	
1490	9.1*	265.62	5.244 x 10 ^{-2*}	49.37	1.200 x 10 ^{-2*}	17.10	1.162 x 10 ^{-3*}
1587	9.7	275.10	5.347*	53.54	1.326	18.90	1.534
1689	1.03 x 10 ⁻¹	284.07	5.431*	58.20	1.457*	20.76	1.991*
1794	1.09	283.79	5.489*	62.97	1.572	22.79	2.564*
1878	1.14	303.63	5.585*	67.49	1.713*	25.09	3.298
2016	1.23*	312.07	5.638	72.06	1.798	27.59	4.173*
2021	1.23	321.16	5.707*	Series 5		30.52	5.259
2081	1.00	328.81	5.769*	41.88	9.621 x 10 ^{-3*}	34.10	6.646*
2086	1.01*	338.07	5.825*	46.53	1.119 x 10 ^{-2*}	37.82	8.066
2213	1.07	346.01	5.865	51.51	1.280*	41.86	9.528*
2277	1.11*	Series 3		58.18	1.460*	46.27	1.102 x 10 ^{-2*}
2393	1.17	5.36	1.188 x 10 ^{-4*}	64.14	1.618*	50.51	1.237*
2483	1.21*	6.59	1.342*	69.39	1.740*	54.86	1.364*
2581	1.27	7.52	1.955*	75.68	1.882*	59.65	1.496
		8.70	2.451	82.91	2.058	65.00	1.633*
		9.89	3.335	90.80	2.242*	71.33	1.781*
		11.17	4.255	Series 6*		78.21	1.942
		12.52	5.328*	80.93	2.009 x 10 ⁻⁴	85.54	2.116*
		13.98	6.976	89.04	2.200	93.32	2.290*
		15.63	9.276	98.01	2.396	101.26	2.466
		17.43	1.242 x 10 ⁻³	106.97	2.591	109.55	2.657*
		19.38	1.667	115.56	2.787	117.74	2.849*
		21.22	2.135	123.87	2.986	125.93	3.037
		23.37	2.764	131.96	3.170	134.64	3.236*
		26.16	3.726	140.19	3.354	144.14	3.444*
		29.24	4.868	CURVE 3		153.80	3.645*
		32.66	6.171	6.08	1.370 x 10 ⁻⁴	162.99	3.826*
		36.34	7.628	6.86	1.664*	172.34	4.002*
		40.51	9.123*	7.78	2.161*	181.73	4.187
		44.29	1.042 x 10 ^{-2*}	8.87	2.721	191.02	4.321*
		48.97	1.192*	10.01	3.482*	200.24	4.466*
		54.58	1.353*	11.25	4.194*	209.21	4.596
		Series 4		13.94	6.803*	218.21	4.721*
		41.18	9.391 x 10 ⁻³	15.43	8.812*	227.36	4.842*
		44.76	1.058 x 10 ⁻²	CURVE 4		236.41	4.952
		48.38	1.173	6.86	1.664*	245.35	5.058*
				7.78	2.161*	254.48	5.154*
				8.87	2.721	263.82	5.247
				10.01	3.482*	273.12	5.337*
				11.25	4.194*	282.27	5.421*
				12.58	5.319	291.43	5.505*
				13.94	6.803*	300.61	5.577*
				15.43	8.812*	309.67	5.650*

* Not shown on plot

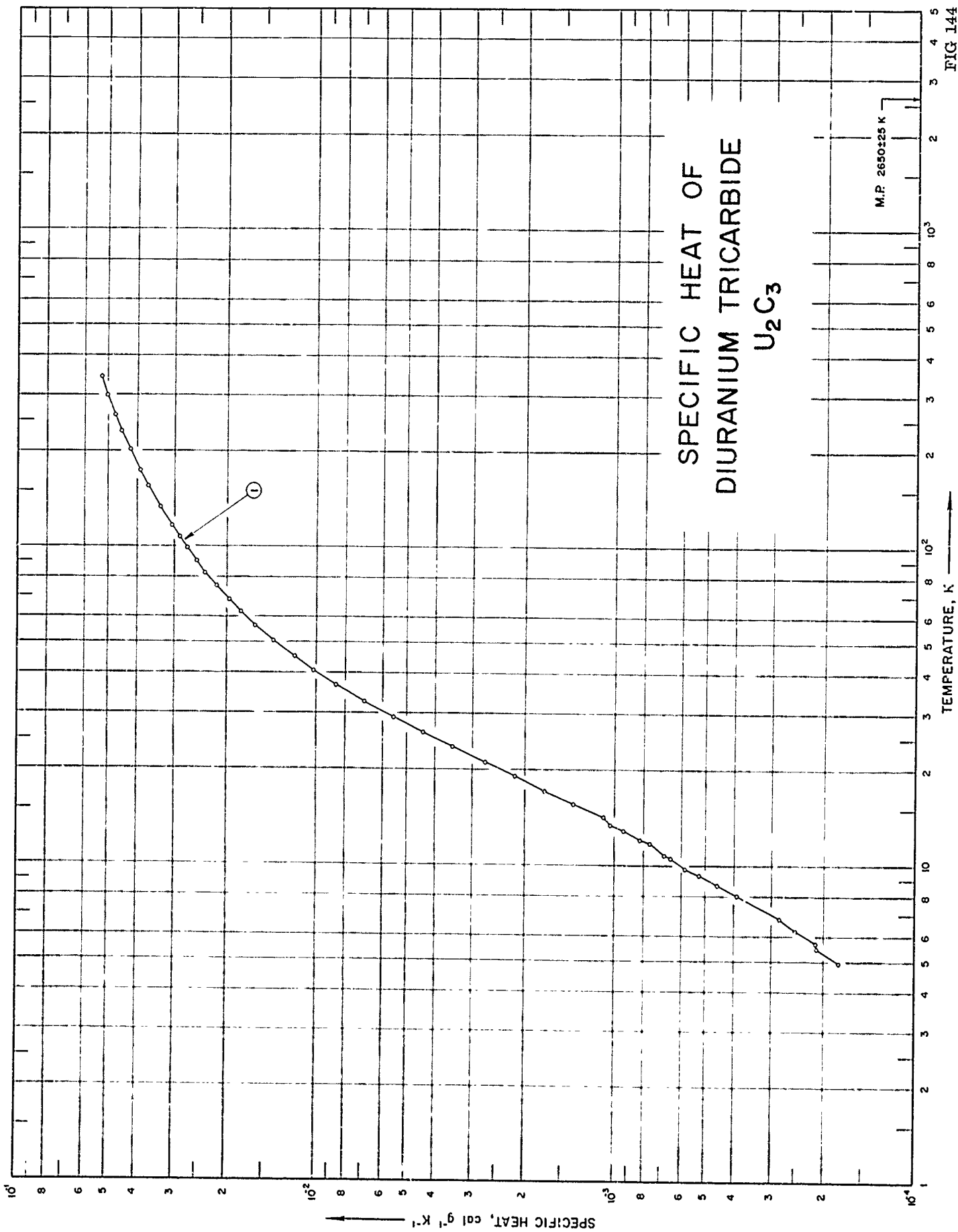

FIG 144

SPECIFICATION TABLE NO. 144 SPECIFIC HEAT OF DIURANIUM TRICARBIDE U_2C_3

[For Data Reported in Figure and Table No. 144]

Curve No.	Ref. No.	Year	Temp. Range, K	Reported Error, %	Name and Specimen Designation	Composition (weight percent), Specifications and Remarks
1	203	1965	5-345	0.1-5		92.9 ± 0.1 U, 6.94 ± 0.03 C, 0.002 ± 0.0005 O ₂ , 0.003 N ₂ , and <0.05 free C.

DATA TABLE NO. 144 SPECIFIC HEAT OF DIURANIUM TRICARBIDE U_2C_3
 [Temperature, T, K; Specific Heat, C_p , Cal $g^{-1} K^{-1}$]

T	C_p	T	C_p
CURVE 1		CURVE 1 (cont.)	
Series 1			
4.92	1.796×10^{-4}	75.29	2.159×10^{-3}
5.48	2.109	82.94	2.367
6.23	2.499	90.65	2.546
3.69	4.589	99.20	2.717
9.74	5.838	108.26	2.893
10.77	6.834	117.09	3.058
12.04	8.279	125.85	3.212*
13.41	1.041×10^{-3}	134.62	3.359
Series 2			
5.70	2.128×10^{-4}	129.60	3.275×10^{-2} *
6.81	2.812	138.02	3.413*
8.06	3.905	146.60	3.540*
9.32	5.253	155.50	3.673
10.52	6.522	164.71	3.796*
11.71	7.654	174.03	3.917
12.89	9.373	183.31	4.026*
14.14	1.097×10^{-3}	192.57	4.130*
15.53	1.386	202.08	4.235
17.16	1.722	211.71	4.327*
Series 3			
19.02	2.160×10^{-3}	221.35	4.427*
21.10	2.724	231.29	4.511
23.60	3.501	241.30	4.604*
26.19	4.401	251.12	4.682*
29.15	5.520	260.89	4.753
32.69	6.946	270.62	4.825*
36.79	8.631	280.45	4.895*
40.85	1.027×10^{-2}	290.41	4.964*
45.18	1.196	300.52	5.026
50.80	1.406	310.77	5.091*
56.60	1.607	320.91	5.141*
62.45	1.799	330.92	5.210*
Series 4			
54.54	1.537×10^{-2} *	338.87	5.247*
61.66	1.774*	344.78	5.284
68.17	1.969		

* Not shown on plot

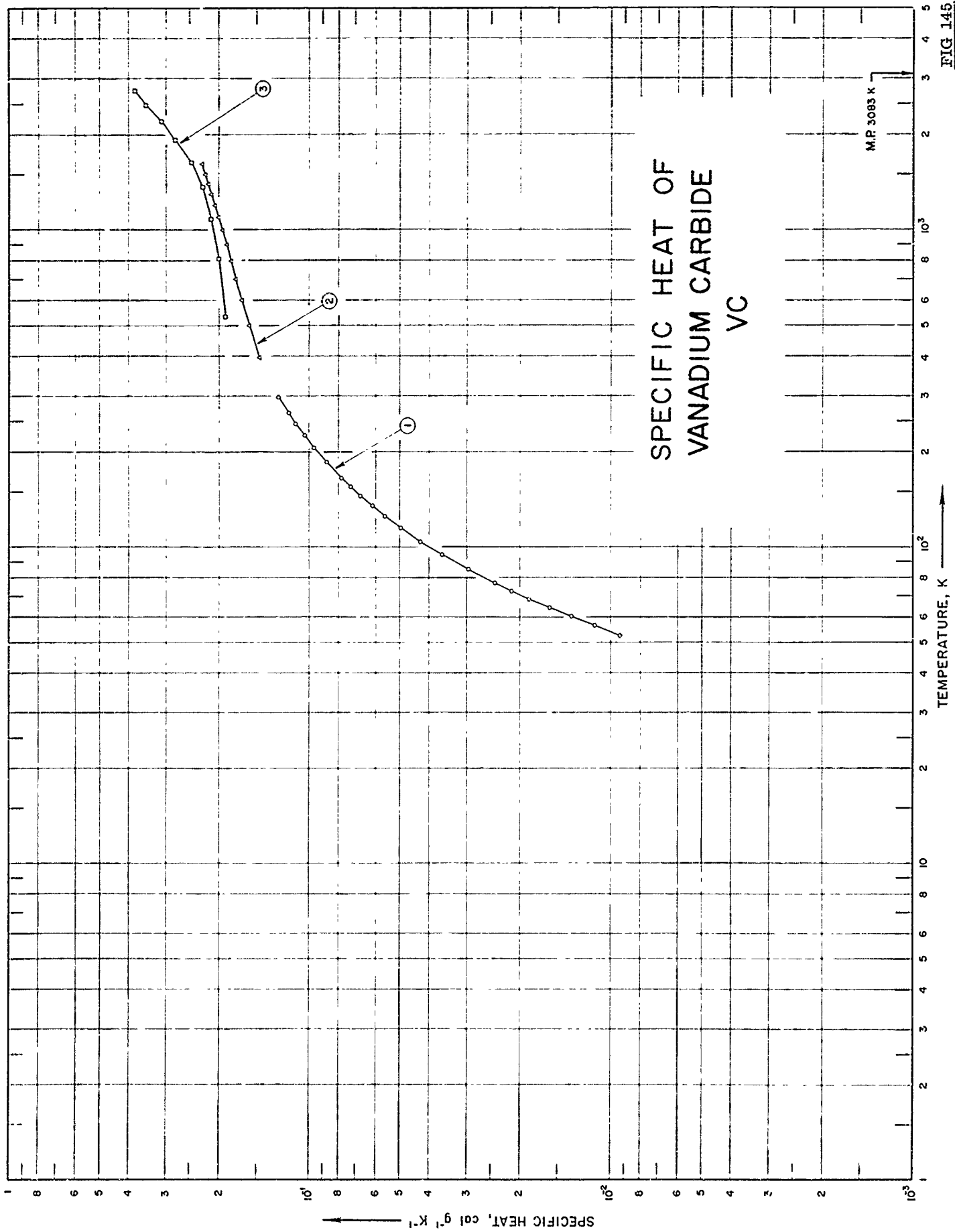

FIG 145

SPECIFICATION TABLE NO. 145 SPECIFIC HEAT OF VANADIUM CARBIDE VC

[For Data Reported in Figure and Table No. 145]

Curve No.	Ref. No.	Year	Temp. Range, K	Reported Error, %	Name and Specimen Designation	Composition (weight percent), Specifications and Remarks
1	204	1949	52-298			80, 90 V and 19.04 C, heated in a vacuum 26 hrs at 1300 - 1350 C, product analyzed and adjusted in composition after 12 and 22 hrs of heating.
2	205	1949	397-1611			Same as above.
3	46	1962	533-2755	<5		Before exposure: 81.0 V, 18.6 C, 0.7 Fe, and 0.5 N, after exposure: 80.8 V, 18.4 C, and 0.3 N; sample supplied by the Carborundum Co; hot pressed; crushed in a hardened steel mortar to pass 100-mesh screen; density at 25 C, before exposure: apparent density (ASTM method B311-58) 338 lb ft ⁻³ , true density (by immersion in xylene) 342 lb ft ⁻³ , after exposure: apparent density 312 lb ft ⁻³ , true density 318 lb ft ⁻³ .

DATA TABLE NO. 145 SPECIFIC HEAT OF VANADIUM CARBIDE VC

[Temperature, T, K; Specific Heat, C_p, Cal g⁻¹ K⁻¹]

T	C _p	
	CURVE 1	CURVE 2 (cont.)
52.50	9.363 x 10 ⁻³	2.121 x 10 ⁻¹
56.50	1.140 x 10 ⁻²	2.176
60.20	1.351	2.231
64.30	1.599	2.285*
68.50	1.866	2.291
72.70	2.146	
77.00	2.433	
85.00	2.972	
94.70	3.632	
104.40	4.282	
115.10	4.975	
125.20	5.599	
135.10	6.185	
145.60	6.774	
155.30	7.298	
165.50	7.816	
175.50	8.318*	
185.60	8.779	
195.90	9.226*	
205.80	9.628	
216.20	1.005 x 10 ⁻¹ *	
226.00	1.041	
235.80	1.076*	
246.10	1.110	
256.20	1.144*	
266.10	1.172	
276.20	1.203*	
286.30	1.238*	
297.00	1.264*	
298.16	1.266	

T	C _p	
	CURVE 2	CURVE 3
533.15	1.900 x 10 ⁻¹	
810.93	2.000	
1088.71	2.130	
1366.48	2.270	
1644.26	2.460	
1922.04	2.800	
2199.82	3.100	
2477.59	3.500	
2755.37	3.800	

CURVE 2	
397.00	1.470 x 10 ⁻¹
400	1.474*
500	1.596
600	1.687
700	1.762
800	1.829
900	1.892
1000	1.951
1100	2.009
1200	2.066

* Not shown on plot

FIGURE SHOWS ONLY 6 OF THE CURVES REPORTED IN TABLE

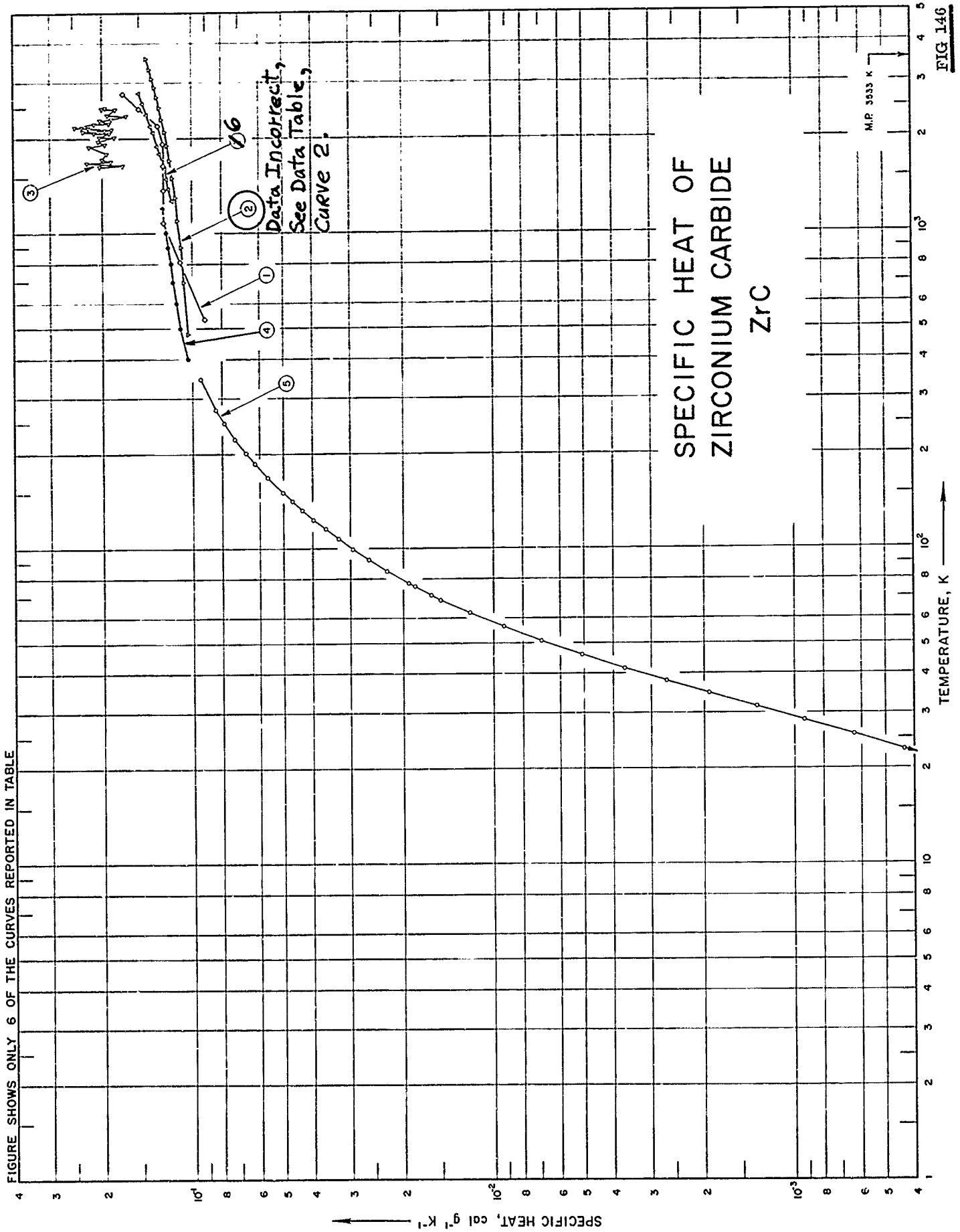

SPECIFICATION TABLE NO. 146 SPECIFIC HEAT OF ZIRCONIUM CARBIDE ZrC

[For Data Reported in Figure and Table No. 146]

Curve No.	Ref. No.	Year	Temp. Range, K	Reported Error, %	Name and Specimen Designation	Composition (weight percent), Specifications and Remarks
1	32	1962	533-2755	±5		Before exposure: 88.5 Zr, 11.0 C, 0.5 N, and 0.1 total impurities, after exposure: 89.3 Zr, 10.8 C, and 0.5 N; sample supplied by the General Electric Co; pressed and sintered: density at 25 C, before exposure: apparent density (ASTM method B311-58) 392 lb ft ⁻³ , true density (by immersion in xylene) 395 lb ft ⁻³ , after exposure: apparent density 289 lb ft ⁻³ , true density 292 lb ft ⁻³ .
2	185	1962	400-1000 522-2240			11.76 total C and 11.09 combined C; sprayed sample.
3	173	1962	1639-2499	5		84.23 Zr, 10.46 total C, 1.21 O ₂ , 1.03 N, 0.78 Hf, <0.3 Nb, 0.25 free C, <0.2 Ni, 0.19 Fe, 0.15 Cu, 0.14 Ti, 0.12 Al, 0.07 V, 0.02 Mn, and <0.01 Mg; solid pieces machined to specifications by using diamond tools and electric discharge techniques.
4	54 54	1963	400-1000 400-1200			89.27 Zr, 11.20 C, 0.005 O ₂ and 0.067 N ₂ impurities: quantitative spectrographic analysis, 0.12 Ti, 0.07 B, 0.07 Fe, 0.001 Si, semi-quantitative spectrographic analysis, 0.01 Al and Sn, 0.001-0.01 Mg, 0.001 Ca, Cu, Hf, Mn, Mo, and Pb; zone-refined.
5	458 458	1963	5-345	0.1-5		89.27 Zr, 11.20 C, 0.005 O ₂ , and 0.067 N ₂ impurities quantitative spectrographic analysis, 0.12 Ti, 0.07 B, 0.07 Fe, and 0.001 Si, semi-quantitative analysis, 0.01 Al and Sn, 0.001-0.01 Mg, 0.001 Ca, Cu, Hf, Mn, Mo, and Pb; zone-refined.
6	196 196	1965 1965	800-1000 1275-2788	±0.70 1.4		Free of O₂, Si, Al, Mn, and Fe; sample supplied by the General Electric Co. 88.24 Zr, 11.13 combined C, 0.24 free C, <0.1 Hf, and 0.05 O ₂ ; lattice parameter a ₀ = 4.6953 ± 0.0002 Å; hot pressed; in graphite dies and then electrosparke machined.

DATA TABLE NO. 146 SPECIFIC HEAT OF ZIRCONIUM CARBIDE ZrC

[Temperature, T, K; Specific Heat, C_p, Cal g⁻¹K⁻¹]

T	C _p	T	C _p	T	C _p	T	C _p	T	C _p	
533	9.100 x 10 ⁻²	2023	2.040 x 10 ⁻¹	2492	1.960 x 10 ⁻¹	301.41	8.820 x 10 ⁻² *	376	9.16 x 10 ⁻²	
811	1.100 x 10 ⁻¹	2057	2.040*	2495	1.910*	336.31	9.303*	400	9.94 x 10 ⁻¹	
1089	1.250	2071	2.080*	2499	1.960	345.16	9.417	500	1.001	
1366	1.250	2080	2.020*	<u>CURVE 4</u>			900	1.136	600	1.136
1644	1.250	2080	2.080*	3000			Series 2*	700	1.164	
1922	1.250	2085	2.080*	400	1.046 x 10 ⁻¹	313.69	9.007 x 10 ⁻²	800	1.176	
2200	1.300	2094	1.890	500	1.101	332.55	9.133	900	1.202	
2478	1.500	2094	2.130	600	1.136	331.36	9.258	100	1.224	
2755	1.700	2100	2.210*	700	1.164	Series 3	1200	1.240		
		2107	2.320	800	1.186	5.59	1.066 x 10 ⁻⁵	1275	1.17 x 10 ⁻¹	
		2113	2.240*	900	1.205	6.75	1.550*	1383	1.20	
		2113	2.240*	1000	1.224	7.85	2.325*	1489	1.22	
		2118	2.240*	1100	1.240	9.11	3.294*	1601	1.24	
		2118	2.100*	1200	1.257	10.43	4.650*	1692	1.26*	
		2132	1.960	<u>CURVE 5</u>			1794	1.29	1794	1.29
		2138	2.130*	71.02	1.607 x 10 ⁻²	11.81	6.200*	1892	1.31	
		2146	2.050*	77.48	1.916	13.30	8.429*	2089	1.35	
		2147	1.860	84.53	2.260	14.83	1.143 x 10 ⁻⁴ *	2191	1.38	
		2164	2.230	92.01	2.604	16.52	1.541*	2282	1.40*	
		2166	2.150*	99.71	2.944	18.44	2.121*	2384	1.42	
		2169	2.340	107.56	3.286	20.59	3.013*	2493	1.44*	
		2172	2.100*	115.66	3.631	22.95	4.331	2591	1.47	
		2175	2.470	123.93	3.978	25.57	6.336	2686	1.49*	
		2175	2.310*	132.58	4.335	28.44	9.252	2788	1.51	
		2189	2.310*	141.47	4.680	31.45	1.340 x 10 ⁻³			
		2198	2.250*	150.35	5.020	34.62	1.913			
		2206	2.080*	159.30	5.341*	37.91	2.661			
		2232	2.110	168.31	5.656	41.60	3.665			
		2238	2.170*	177.30	5.954*	45.97	5.064			
		2238	2.110*	186.29	6.240	50.94	6.942			
		2243	2.110*	195.30	6.511*	56.46	9.259			
		2249	1.890	202.32	7.242	62.43	1.200 x 10 ⁻²			
		2252	2.010*	211.69	7.471*	68.86	1.501			
		2286	2.030	231.69	7.689*	75.78	1.831			
		2298	2.130*	240.94	7.883	201.94	6.698			
		2306	2.000*	248.71	8.069*	205.90	6.814*			
		2310	1.860	258.94	8.236*	213.67	7.014*			
		2364	1.670	267.48	8.406	217.49	7.117*			
		1639	2.040 x 10 ⁻¹	292.81	8.692*					
		1648	1.710							
		1675	2.250							
		1696	1.870							
		1721	2.000							
		1799	1.930							
		1814	1.950*							
		1897	2.210							
		1915	1.960							
		1955	2.060							
		2017	1.820							

* Not shown on plot

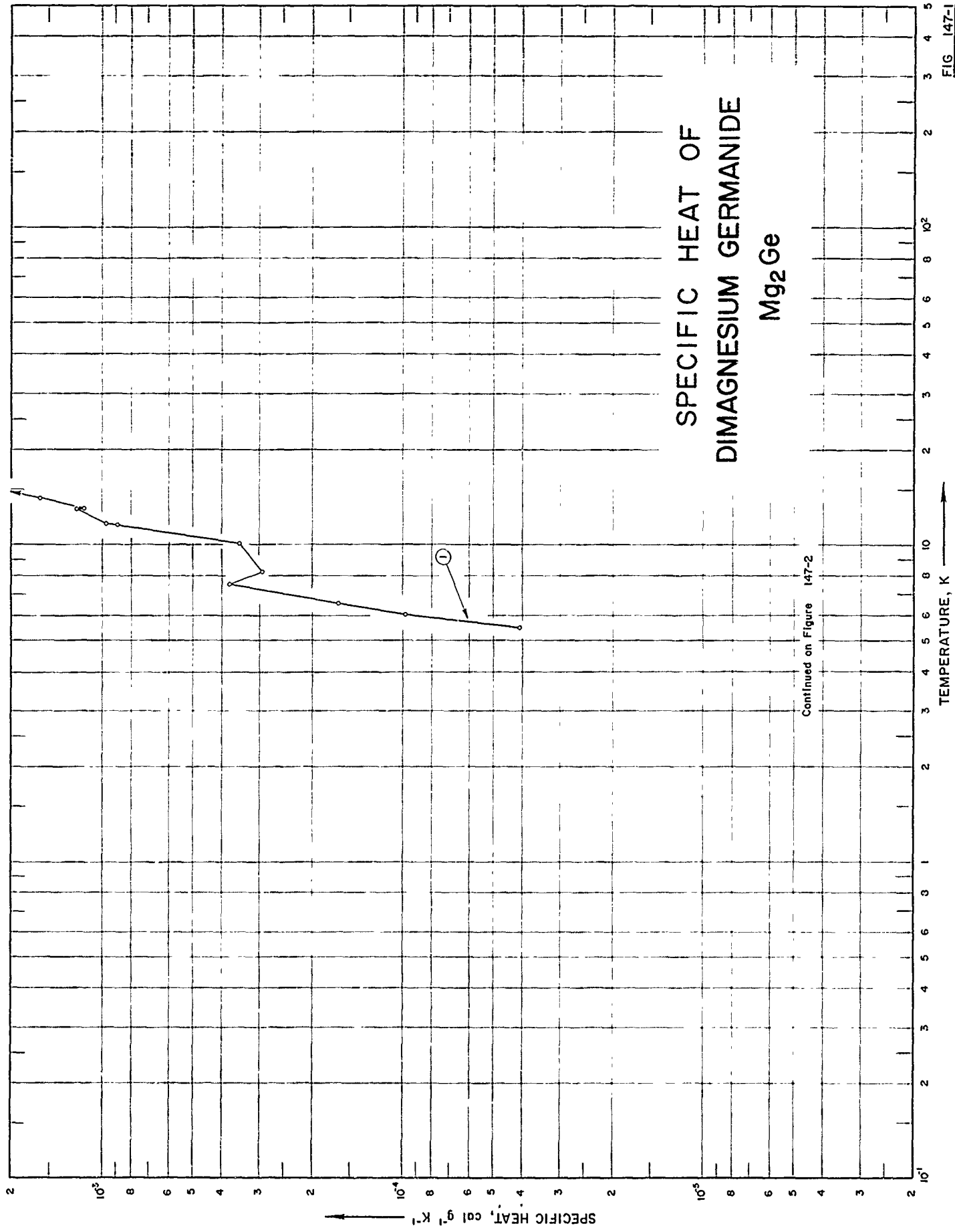

Continued on Figure 147-2

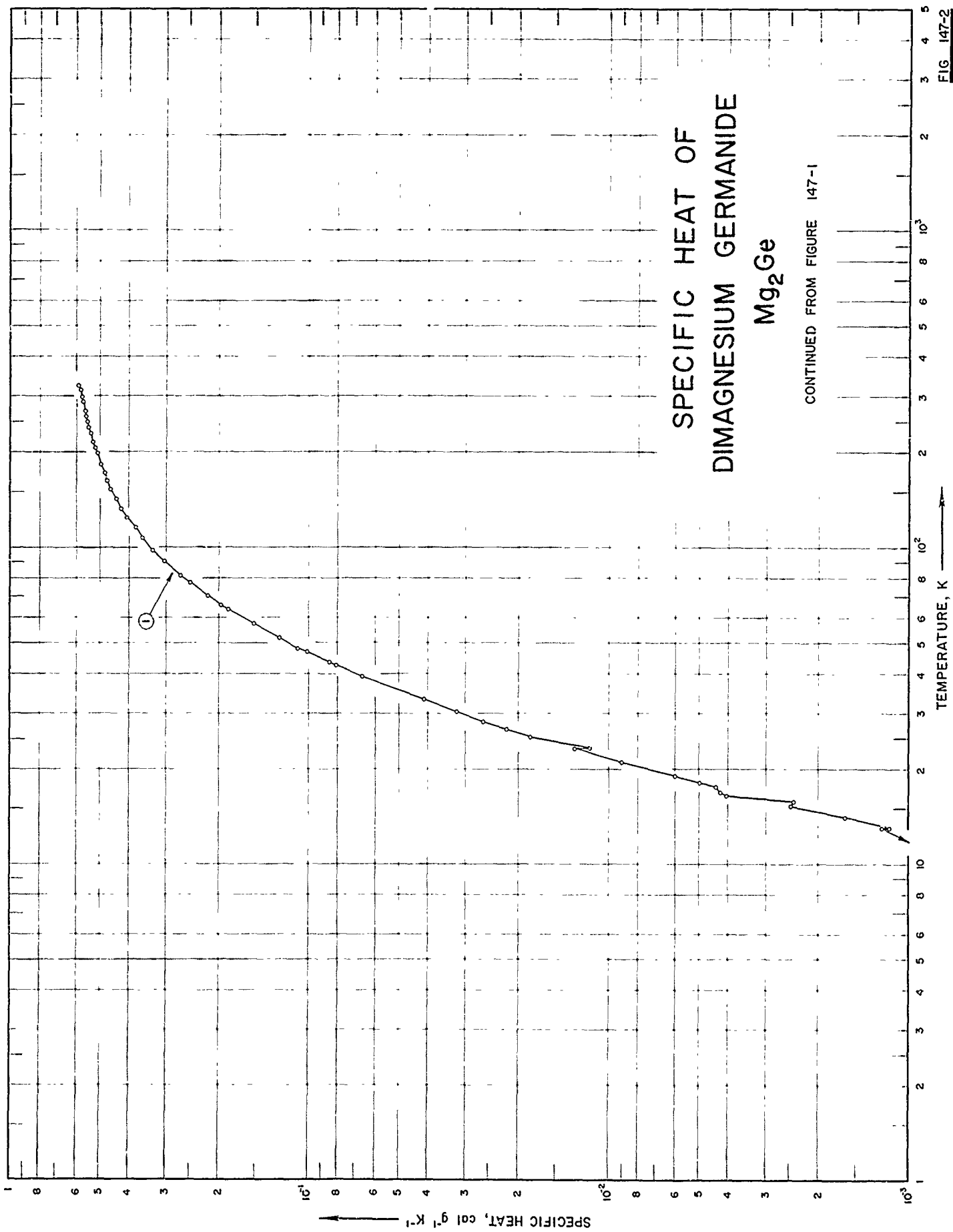

SPECIFICATION TABLE NO. 147 SPECIFIC HEAT OF DIMAGNESIUM GERMANIDE Mg_2Ge

[For Data Reported in Figure and Table No. 147]

Curve No.	Ref. No.	Year	Temp. Range, K	Reported Error, %	Name and Specimen Designation	Composition (weight percent), Specifications and Remarks
1	407	1966	6-325			Prepared from stoichiometric proportions of Mg (99.99) and Ge; 40 ohm cm resistivity.

DATA TABLE NO. 147 SPECIFIC HEAT OF DIMAGNESIUM GERMANIDE Mg_2Ge [Temperature, T, K; Specific Heat, C_p , Cal $g^{-1}K^{-1}$]

T	C_p	T	C_p	T	C_p
CURVE 1		CURVE 1 (cont.)		CURVE 1 (cont.)	
Series 1					
6.97	9.900×10^{-5}	250.4	5.510×10^{-1}	82.4	2.696×10^{-1}
7.53	3.795×10^{-4}	260.4	5.574	91.6	3.074
11.69	9.817	270.3	5.628	100.5	3.387
13.04	1.163×10^{-3}	277.9	5.639*	109.7	3.656
14.16	1.625	289.4	5.725	119.5	4.155
15.34	2.475	298.7	5.760	140.8	4.363
16.58	4.067	308.4	5.833*	152.2	4.565
17.69	4.422	315.7	5.823	163.8	4.767
19.06	6.039	325.0	5.918	175.1	4.879
23.35	1.165×10^{-2}	Series 5			
25.38	1.823	5.51	4.125×10^{-5}	186.1	5.020
28.34	2.623	6.58	1.650×10^{-4}	196.9	5.121
Series 2					
39.39	6.616×10^{-2}	8.27	2.970	207.7	5.230
43.77	8.514	10.14	3.547	218.3	5.369
48.31	1.090×10^{-1}	11.62	8.992	Series 8*	
66.32	1.968	13.01	1.229×10^{-3}	228.7	5.352×10^{-1}
Series 3					
82.0	2.692×10^{-1}	14.35	1.633*	238.9	5.475
90.8	3.057	15.72	2.425	249.0	5.527
99.1	3.344	16.92	4.282	259.0	5.567
107.6	3.617	18.12	4.991	268.8	5.602
116.4	3.798	19.48	6.146*	278.7	5.658
125.2	4.082	21.02	9.075	288.5	5.724
133.1	4.254	23.24	1.312×10^{-2}	298.2	5.718
143.0	4.417	26.78	2.186	307.9	5.780
152.7	4.606	30.46	3.209	Series 6	
162.9	4.741	33.26	4.125	29.1	6.559×10^{-2} *
172.9	4.826	Series 4			
183.8	4.988	219.9	5.322×10^{-1} *	42.7	8.110*
199.7	5.112	230.1	5.395	47.0	1.011×10^{-1}
206.4	5.206	240.3	5.485	52.0	1.255
215.8	5.300	Series 7*			
Series 4					
219.9	5.322×10^{-1} *	82.4	2.696×10^{-1}	70.7	2.179
230.1	5.395	91.6	3.074	77.8	2.512
240.3	5.485	100.5	3.387		

* Not shown on plot

SPECIFIC HEAT OF
ANTIMONY SULFUR IODIDE
SbSI

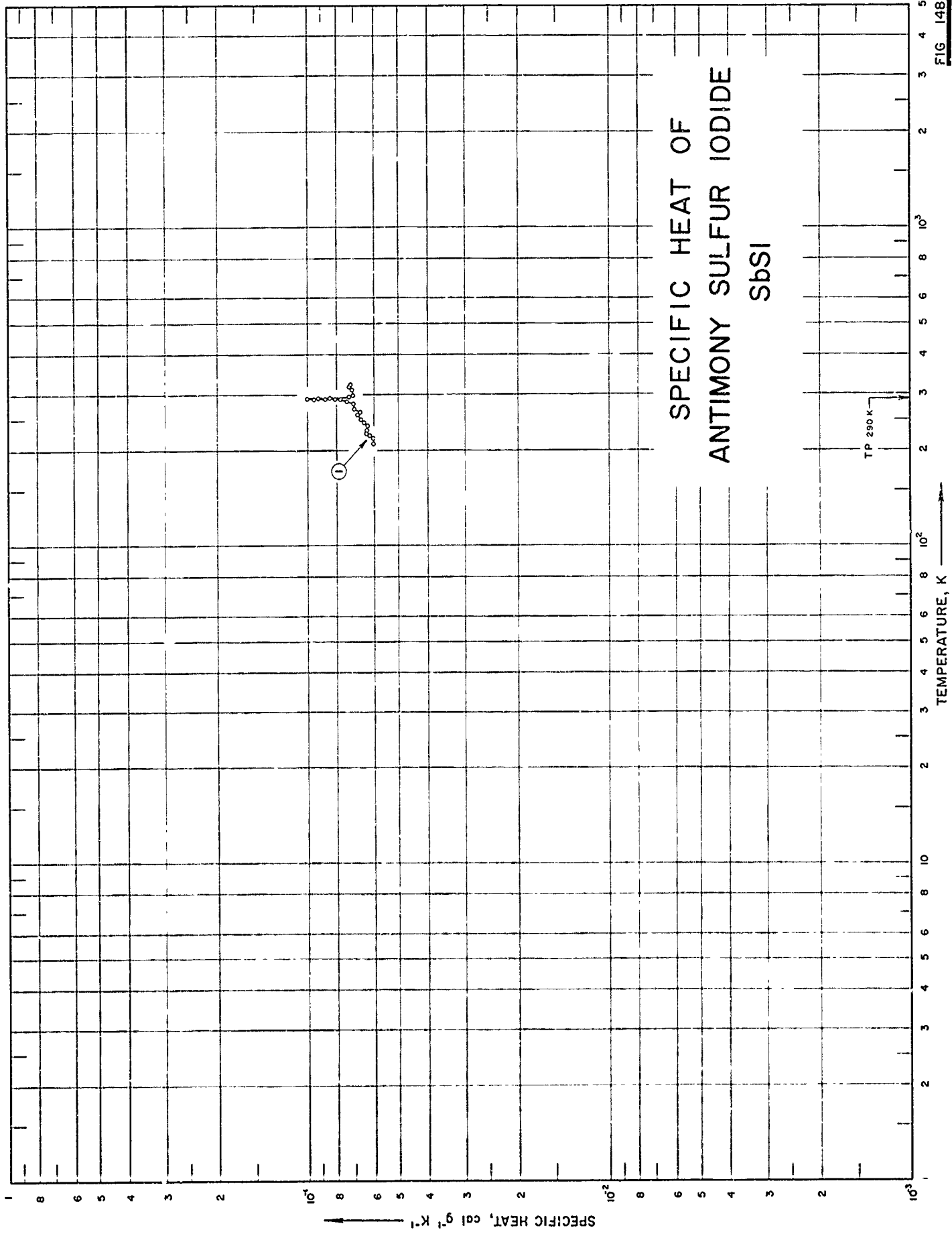

SPECIFICATION TABLE NO. 148 SPECIFIC HEAT OF ANTIMONY SULFUR IODIDE SbSI

[For Data Reported in Figure and Table No. 148.]

Curve No.	Ref. No.	Year	Temp. Range, K	Reported Error, %	Name and Specimen Designation	Composition (weight percent), Specifications and Remarks
1	336	1965	210-325			99.9999 SbSI; polycrystalline; prepared from SbI ₃ and Sb ₂ S ₃ ; sealed in evacuated pyrex ampule; heated to 500 C; melt cooled to room temperature in two days.

DATA TABLE NO. 148 SPECIFIC HEAT OF ANTIMONY SULFUR IODIDE SbSI

[Temperature, T, K; Specific Heat, C_p , Cal $g^{-1}K^{-1}$]

T	C_p	T	C_p	T	C_p
210.25	6.02×10^2	250.75	6.63×10^2	291.25	1.01×10^{10}
211.25	5.95*	251.55	6.63*	291.45	9.87×10^{10} *
212.05	5.98*	254.55	6.63*	291.45	9.58
214.25	5.98*	255.75	6.77*	291.65	1.01×10^{10} *
215.15	6.13*	256.45	6.59*	291.85	1.05*
215.85	6.06*	257.55	6.77*	291.95	9.94×10^{10} *
217.35	6.02*	258.35	6.77*	292.15	9.26
218.25	5.98*	259.25	6.80*	292.25	9.30*
219.15	6.02	260.55	6.73	292.45	9.62*
220.05	6.13*	261.55	6.73*	293.15	8.48
		262.35	6.73*	293.85	7.84*
		263.35	6.77*	294.55	7.69*
		264.25	6.84*	295.55	7.45*
		265.25	6.77	296.45	7.30
217.65	6.13×10^{10} *	266.05	6.84*	297.15	7.20*
218.85	6.16*	267.05	6.95*	297.95	7.27*
219.75	6.16*	267.95	6.98*	299.05	7.12
220.65	6.16*	268.95	7.02*	299.75	7.13*
221.85	6.06*	269.95	7.09*	300.45	7.16*
222.75	6.26*	270.85	6.98	301.15	6.91*
223.65	6.23	271.55	6.91*	301.95	7.05*
224.85	5.30*	272.35	7.09*	302.75	7.02*
225.75	6.27*	273.41	6.91*	303.55	7.09*
227.45	6.34	274.19	6.95*	312.15	7.16
228.35	6.27*	274.97	7.05*	312.95	7.09*
229.55	6.27*	275.75	6.98*	314.15	7.09*
231.55	6.20*	277.29	6.91*	317.65	7.30
232.45	6.38	278.06	6.88*	318.35	7.16*
233.55	6.23*	278.83	7.05*	319.05	7.09*
234.45	6.34	281.90	7.03	320.05	7.26*
235.35	6.31*	282.67	7.37*	320.75	7.23*
238.15	6.37*	283.45	7.41*	321.45	7.29*
239.35	6.37*	284.15	7.30*	322.15	7.16*
240.15	6.34	285.25	7.20*	323.15	7.20*
241.05	6.34*	285.95	7.45	323.95	7.12*
242.15	6.37*	286.75	7.37*	324.05	7.20
243.15	6.34*	287.45	7.34*		
243.85	6.45*	288.25	7.62*		
244.95	6.45*	288.75	7.80*		
245.75	6.55	288.95	7.91*		
246.75	6.52*	289.45	8.34*		
247.75	6.52*	289.75	7.87*		
248.55	6.45*	290.45	7.77		
249.65	6.63*	290.65	8.12*		

* Not shown on plot

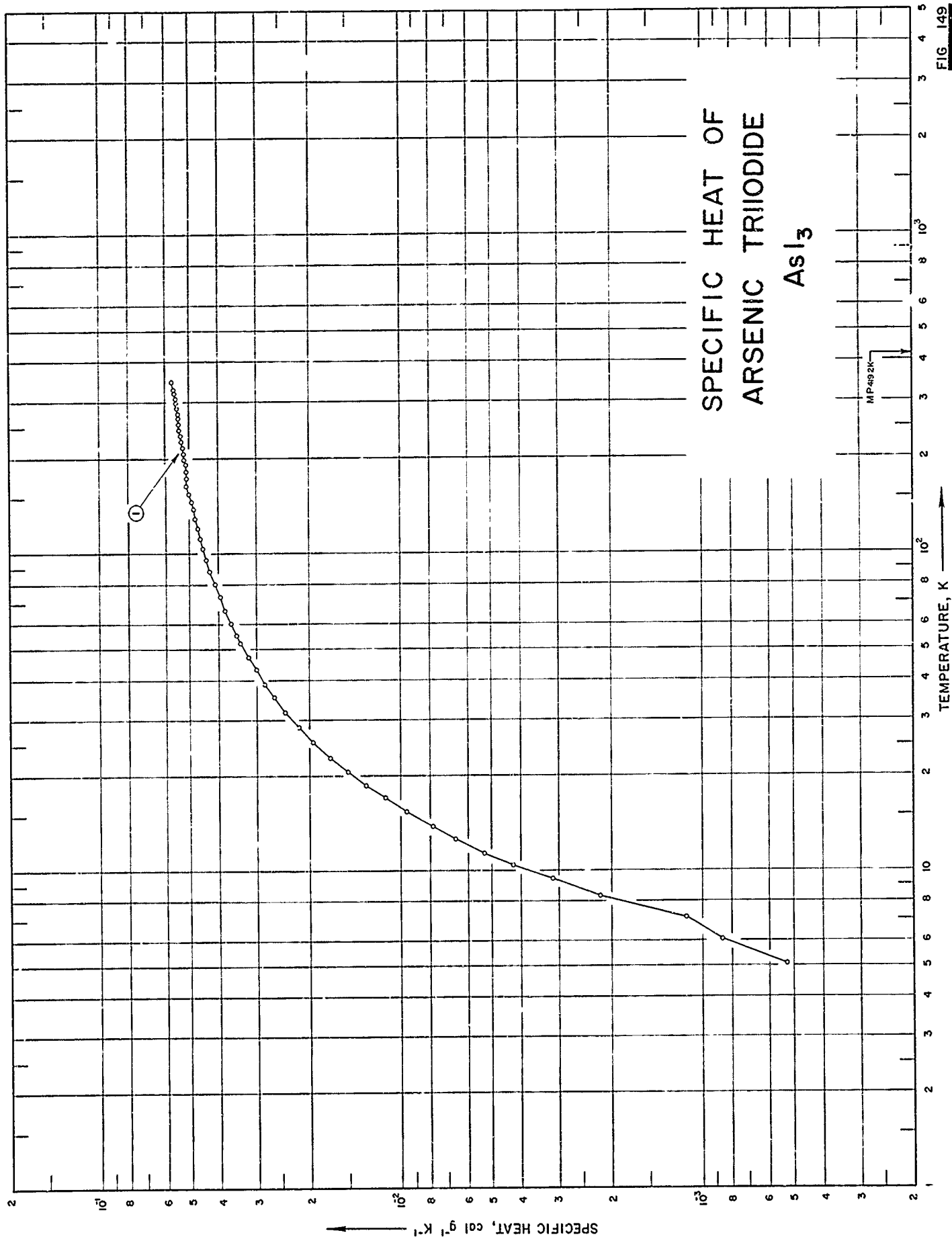

SPECIFICATION TABLE NO. 149 SPECIFIC HEAT OF ARSENIC TRIIODIDE AsI_3

[For Data Reported in Figure and Table No. 149]

Curve No.	Ref. No.	Year	Temp. Range, K	Reported Error, %	Name and Specimen Designation	Composition (weight percent), Specifications and Remarks
1	327	1955	5-349	$\pm 0.15-6.0$		83.30 I and 16.45 As, (83.60 and 16.44 theo).

DATA TABLE NO. 149 SPECIFIC HEAT OF ARSENIC TRIIODIDE AsI_3
 [Temperature, T, K; Specific Heat, C_p , Cal $g^{-1}K^{-1}$]

T	C_p	T	C_p	T	C_p
$\frac{CURVE I}{Series I}$		$\frac{CURVE I (cont.)}{Series III}$		$\frac{CURVE I (cont.)}{Series VII^*}$	
5.11	5.27×10^{-4}	197.77	5.217×10^{-2}	256.05	5.456×10^{-2}
6.08	8.56	207.28	5.230	266.16	5.504
7.17	1.40×10^{-3}	216.95	5.294	276.28	5.511
8.33	2.19	226.99	5.335	286.49	5.520
9.43	3.14	237.22	5.377	296.83	5.548
10.46	4.28	247.54	5.417	305.07	5.570
11.48	5.331	257.83	5.452	315.20	5.605
12.64	6.540	268.14	5.454	325.33	5.643
13.92	7.886	278.56	5.476	335.59	5.678
15.44	9.591	289.04	5.520	345.85	5.715
17.02	1.134×10^{-2}	299.47	5.550		
18.69	1.308	309.85	5.586	Series VIII	
20.60	1.504	320.20	5.625	238.00	5.381×10^{-2}
22.89	1.725	330.52	5.669	248.52	5.419
25.50	1.957	340.84	5.711*	258.86	5.480
28.45	2.189	348.61	5.744	266.63	5.504
31.70	2.421			271.88	5.509
35.19	2.638	Series IV*		277.13	5.520
38.95	2.840	142.59	4.923×10^{-2}	282.47	5.528
43.07	3.033	151.76	4.986		
47.66	3.228	161.01	5.051		
52.70	3.415	170.79	5.094		
		180.74	5.147		
		Series V*			
55.21	3.501×10^{-2}	151.13	4.991×10^{-2}		
60.44	3.665	158.04	5.019		
66.63	3.839	163.22	5.057		
73.47	3.999	166.23	5.072		
80.79	4.161	169.42	5.105		
88.21	4.306				
95.86	4.422	Series VI*			
104.09	4.532	196.72	5.212×10^{-2}		
112.53	4.635	207.35	5.256		
121.01	4.727	218.09	5.298		
129.39	4.811	228.67	5.340		
137.85	4.881	239.08	5.384		
146.45	4.945	249.34	5.432		
155.21	5.011				
163.96	5.153				
172.85	5.107				
182.33	5.153				
192.02	5.195				

* Not shown on plot

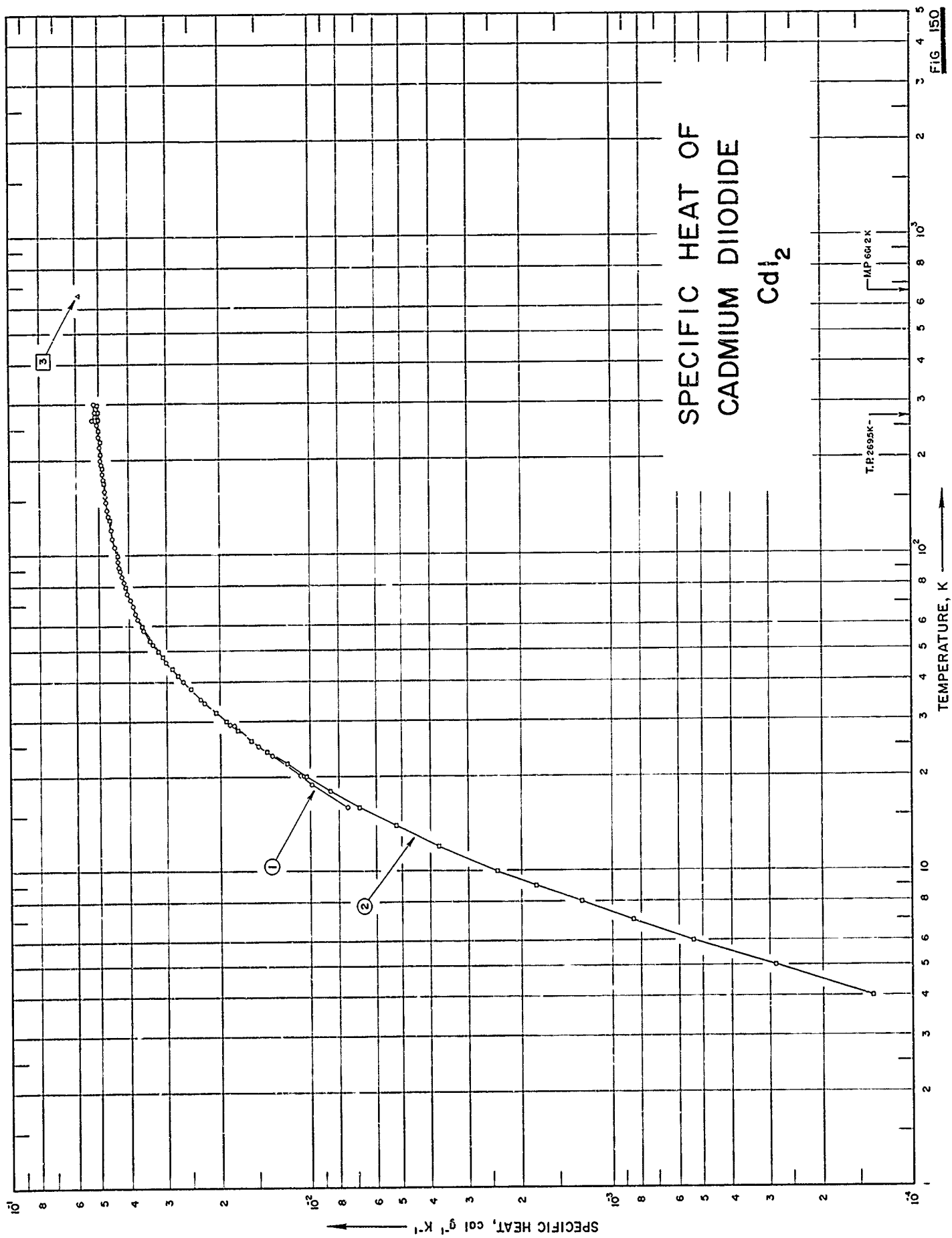

SPECIFICATION TABLE NO. 150 SPECIFIC HEAT OF CADMIUM DIIODIDE CdI_2

[For Data Reported in Figure and Table No. 150]

Curve No.	Ref. No.	Year	Temp. Range, K	Reported Error, %	Name and Specimen Designation	Composition (weight percent), Specifications and Remarks
1	303	1955	16-299	< 0.2-0.5		C. P. analyzed CdI_2 ; sample supplied by the J. T. Baker Chem. Co; dried in oven for 20 hrs a. 115 C; cooled in dessicator.
2	248	1959	2.0-300	1.0		
3	242	1961	661.2			

DATA TABLE NO. 150 SPECIFIC HEAT OF CADMIUM DIODIDE CdI₂[Temperature, T, K; Specific Heat, C_p, Cal g⁻¹K⁻¹]

T	C _p	T	C _p	T	C _p	T	C _p	T	C _p	T	C _p	T	C _p		
Series I															
CURVE 1		CURVE I (cont.)		CURVE I (cont.)		CURVE I (cont.)		CURVE I (cont.)		CURVE I (cont.)		CURVE 2 (cont.)			
Series I		Series V		Series VIII		Series IX		Series X		Series XI		CURVE 3			
16.08	7.531 x 10 ⁻³	109.69	4.504 x 10 ⁻² *	259.11	5.087 x 10 ⁻² *	268.40	5.178 x 10 ⁻² *	2	1.67 x 10 ⁻⁵ *	75	4.036 x 10 ⁻² *	295	5.068 x 10 ⁻² *		
20.24	1.085 x 10 ⁻²	115.17	4.559 [*]	265.43	5.140 [*]	272.69	5.151 [*]	3	5.61 [*]	80	4.129	298.16	5.074 [*]		
25.05	1.493	120.54	4.599 [*]	271.71	5.155	264.82	5.122 [*]	4	1.37 x 10 ⁻⁴	85	4.209 [*]	300	5.077		
29.33	1.865	126.95	4.642 [*]	277.96	5.167 [*]	267.13	5.209 [*]	5	2.88	90	4.272 [*]	CURVE 3			
34.37	2.264	133.55	4.686	285.30	5.190 [*]	269.41	5.297	6	5.39	95	4.328 [*]				
40.08	2.666	140.87	4.730	293.73	5.190 [*]	271.70	5.139 [*]	7	8.54	100	4.378				
46.40	3.034	148.06	4.766	302.12	5.237	274.01	5.171 [*]	8	1.27 x 10 ⁻³	105	4.425 [*]				
Series II															
Series II		Series VI		Series IX		Series X		Series XI		Series IX				Series X	
18.97	9.936 x 10 ⁻³	155.15	4.800	247.39	5.067 x 10 ⁻² *	276.32	5.154 [*]	10	2.41	110	4.471 [*]			661.2	5.87 x 10 ⁻²
23.31	1.245 x 10 ⁻²	161.30	4.828	256.01	5.092 [*]	281.92	5.171 [*]	12	3.76	115	4.512 [*]			CURVE 2	
29.10	1.795	168.23	4.853 [*]	264.58	5.149 [*]	285.30	5.198 [*]	14	5.23	120	4.554 [*]				
35.32	2.328	Series VI		273.51	5.179 [*]	290.30	5.198 [*]	16	6.90	125	4.592 [*]				
40.60	2.678 [*]	133.60	4.681 x 10 ⁻² *	281.92	5.171 [*]	298.66	5.209	18	9.61	130	4.630				
46.54	3.044 [*]	140.92	4.737 [*]	289.30	5.198 [*]	Series X		20	1.01 x 10 ⁻²	135	4.663 [*]				
52.77	3.358	148.11	4.765 [*]	298.66	5.209	209.26	4.981 x 10 ⁻² *	22	1.21	140	4.696 [*]				
54.13	3.425	155.20	4.794 [*]	209.26	4.981 x 10 ⁻² *	215.78	4.991 [*]	24	1.40	145	4.726 [*]				
58.35	3.597	161.55	4.823 [*]	215.78	4.976	222.27	5.006 [*]	26	1.58	150	4.756 [*]				
63.43	3.763	168.48	4.846 [*]	221.79	4.993	228.73	5.012 [*]	28	1.75	155	4.781 [*]				
69.46	3.892	175.33	4.878	228.73	5.012 [*]	235.15	5.033	30	1.92	160	4.803 [*]				
76.38	4.048	182.12	4.897	235.15	5.033	241.54	5.049	32	2.08	170	4.844				
82.89	4.184	188.85	4.925	241.54	5.049	247.90	5.057	34	2.24	175	4.860 [*]				
Series III															
Series III		Series VII		Series X		Series XI		Series XII		Series XIII		Series XIV			
54.20	3.418 x 10 ⁻² *	177.10	4.882 x 10 ⁻² *	247.90	5.057	254.23	5.058	36	2.37	180	4.879 [*]	210	4.959		
59.61	3.648 [*]	183.88	4.909	254.23	5.058	260.52	5.087	38	2.51	185	4.893 [*]	215	4.967 [*]		
65.91	3.819	190.61	4.931	260.52	5.087	266.81	5.116	40	2.64	190	4.910	220	4.978 [*]		
73.10	3.975	197.29	4.946 [*]	266.81	5.116	273.14	5.143	42	2.766	200	4.923 [*]	225	4.986 [*]		
79.82	4.118 [*]	202.52	4.953 [*]	273.14	5.155	279.75	5.180	44	2.881	205	4.948 [*]	230	4.994		
86.18	4.241	209.26	4.961 [*]	279.75	5.180	285.91	5.192	46	2.990 [*]	210	4.967 [*]	235	5.000 [*]		
92.27	4.331	211.49	4.976 [*]	285.91	5.192	292.11	5.205 [*]	48	3.100	215	4.967 [*]	240	5.005 [*]		
Series IV															
Series IV		Series VII		Series X		Series XI		Series XII		Series XIII		Series XIV			
89.73	4.308 x 10 ⁻²	211.49	4.976 [*]	292.11	5.205 [*]	298.21	5.205	50	3.204	220	4.978 [*]	250	5.016		
95.72	4.355	220.38	4.998 [*]	298.21	5.205	304.41	5.237	52	3.311	225	4.986 [*]	255	5.022 [*]		
101.53	4.424 [*]	229.21	5.018 [*]	304.41	5.237	310.61	5.269	54	3.418	230	4.994	260	5.027 [*]		
107.18	4.485	237.97	5.037	310.61	5.269	316.81	5.299	56	3.525	235	5.000 [*]	265	5.033 [*]		
113.84	4.544	246.67	5.062	316.81	5.299	323.01	5.329	58	3.632	240	5.005 [*]	270	5.038		
121.57	4.599	255.47	5.073	323.01	5.329	329.21	5.359	60	3.739	245	5.005 [*]	275	5.044 [*]		
129.12	4.653	264.28	5.100	329.21	5.359	335.41	5.389	62	3.846	250	5.016	280	5.049 [*]		
		269.66	5.194 [*]	335.41	5.389	341.61	5.419	64	3.953	255	5.022 [*]	285	5.057		
				341.61	5.419	347.81	5.449	66	4.060	260	5.027 [*]	290	5.063 [*]		

* Not shown on plot

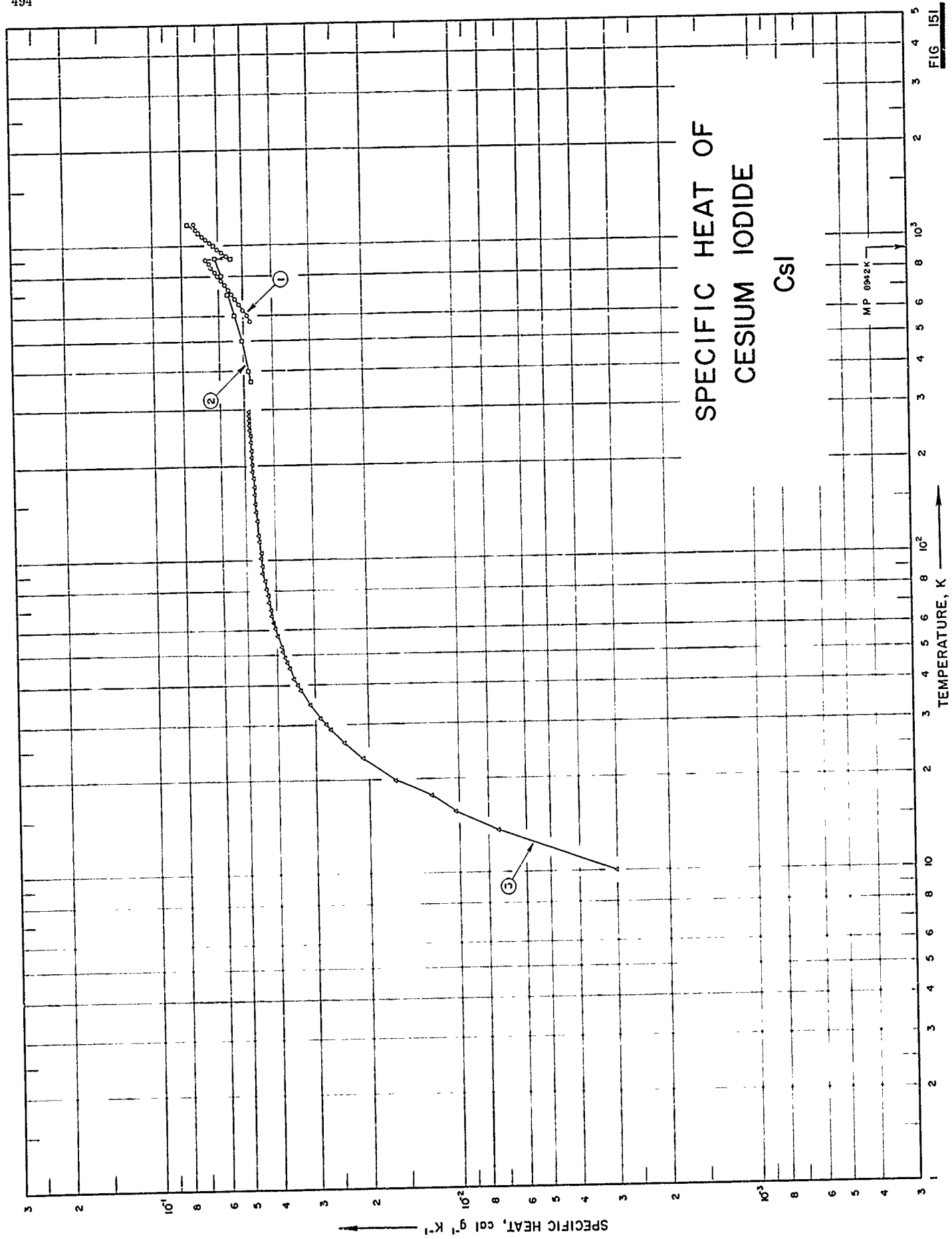

SPECIFICATION TABLE NO. 151 SPECIFIC HEAT OF CESIUM IODIDE CsI

[For Data Reported in Figure and Table No. 151]

Curve No.	Ref. No.	Year	Temp. Range, K	Reported Error, %	Name and Specimen Designation	Composition (weight percent), Specifications and Remarks
1	251	1958	575-1175			99.80 CsI.
2	252	1961	370-1172			
3	253	1963	14-298	0.3		> 99.989 CsI, 0.001-0.01 Ca, Na, 0.0001-0.001 Al and K; chemically pure grade sample was recrystallized several times from water; dried at 260 to 300 C in a vacuum oven for several hrs.

DATA TABLE NO. 151 SPECIFIC HEAT OF CESIUM IODIDE CsI

[Temperature, T, K; Specific Heat, C_p , Cal $g^{-1}K^{-1}$]

T	CURVE 1		CURVE 3		CURVE 3 (cont.)	
	C_p	T	C_p	T	C_p	T
575	4.747 x 10 ⁻²	10.00	3.002 x 10 ⁻³	201.94	4.736 x 10 ⁻²	201.94
600	4.886	13.51	7.417	207.13	4.744 ^a	207.13
625	5.026	15.52	1.028 x 10 ⁻²	213.72	4.754	213.72
650	5.167	17.06	1.242	224.08	4.761	224.08
675	5.309	19.80	1.638	230.28	4.770 ^b	230.28
700	5.453	23.39	2.100	239.24	4.782	239.24
725	5.597	26.24	2.413	250.06	4.794	250.06
750	5.742	28.92	2.676	259.14	4.809	259.14
775	5.888	30.00	2.775	269.17	4.819	269.17
800	6.034	31.53	2.898	278.63	4.826	278.63
825	6.181	34.83	3.143	288.16	4.849	288.16
850	6.329	38.73	3.366	298.39	4.857	298.39
875	6.477	40.00	3.425			
900	6.624	42.27	3.528			
(s)907	6.666 ^c	45.53	3.654			
(l)907	5.491 ^a	47.45	3.721			
925	5.643	48.59	3.751 ^c			
950	5.850	49.12	3.771			
975	6.051	51.48	3.848			
1000	6.246	52.00	3.859			
1025	6.436	54.74	3.931 ^c			
1050	6.622	57.62	3.992			
1075	6.803	58.50	4.010 ^a			
1100	6.982	60.64	4.054			
1125	7.156	63.31	4.104			
1150	7.328	63.99	4.116 ^c			
1175	7.497	66.40	4.155			
		69.62	4.190			
		73.59	4.234			
		77.43	4.285			
		81.14	4.326			
		85.71	4.374			
		91.11	4.405			
		96.33	4.433			
		101.42	4.460			
		106.39	4.478			
		115.66	4.518			
(s)904	6.177	124.97	4.561			
(l)908	5.489 ^c	133.98	4.591			
1060	6.238	142.77	4.617			
1100	7.051 ^c	152.63	4.641			
1172	7.636	162.78	4.662			
		172.45	4.682			
		181.69	4.697			
		191.87	4.718			

Not shown on plot

FIG 152

SPECIFIC HEAT OF LEAD DIIODIDE PbI_2

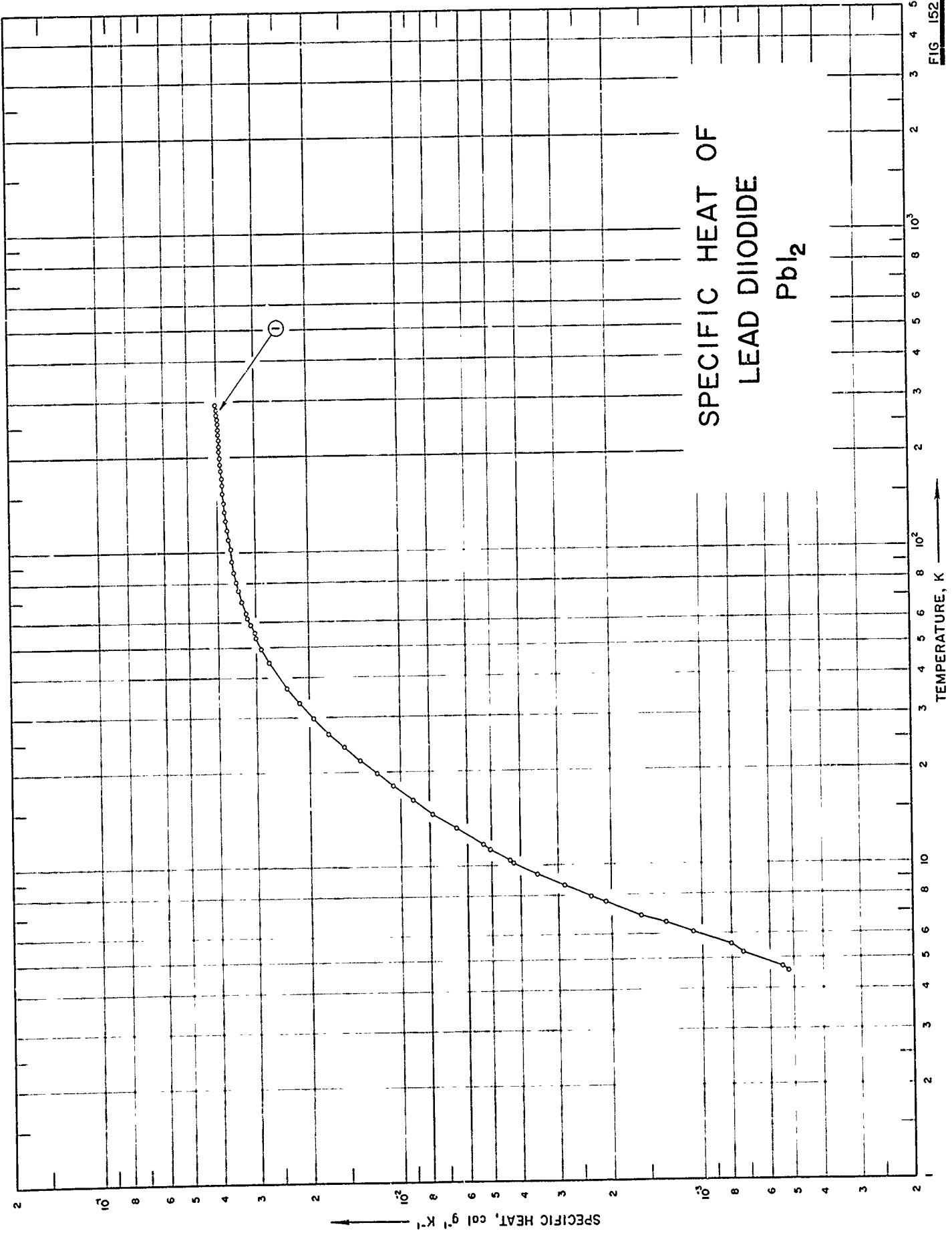

SPECIFICATION TABLE NO. 152 SPECIFIC HEAT OF LEAD DIODIDE PbI_2

[For Data Reported in Figure and Table No. 152.]

Curve No.	Ref. No.	Year	Temp. Range, K	Reported Error, %	Name and Specimen Designation	Composition (weight percent), Specifications and Remarks
1	327	1955	4.7-291	0.15-6.0		55.10 I and 44.82 Pb, (55.05 and 44.95 theo); hemispherical pelletizing sample.

DATA TABLE NO. 152 SPECIFIC HEAT OF LEAD DIODIDE PbI_2
 Temperature, T, K. Specific Heat, C_p , Cal $g^{-1}K^{-1}$.

T	C_p	T	C_p
	$\frac{CURVE 1}{Series I}$		$\frac{CURVE 1 (cont.)}{Series I}$
4.70	5.423×10^{-4}	102.00	3.629×10^{-2}
5.52	8.026	109.99	3.672
6.53	1.323×10^{-3}	118.20	3.713
7.97	2.343	126.73	3.750
8.67	2.885	135.28	3.779
10.24	4.230	143.90	3.802
11.29	5.054	154.11	3.831
		162.76	3.848
		171.74	3.863
		172.09	3.870
		181.19	3.878
		190.28	3.893
		199.37	3.906
		208.51	3.922
		217.72	3.928
		227.02	3.939
		236.24	3.948
		245.43	3.959
		254.60	3.969
		263.72	3.978
		272.77	4.000
		281.86	4.002
		291.00	4.011
			Series IV
		80.09	3.468×10^{-2}
			Series V
		159.09	3.837×10^{-2}
		167.55	3.854
			Series III
		53.82	3.004×10^{-2}
		59.13	3.132
		64.24	3.238
		69.79	3.325
		75.89	3.408
		86.13	3.529
		93.74	3.583

* Not shown on plot

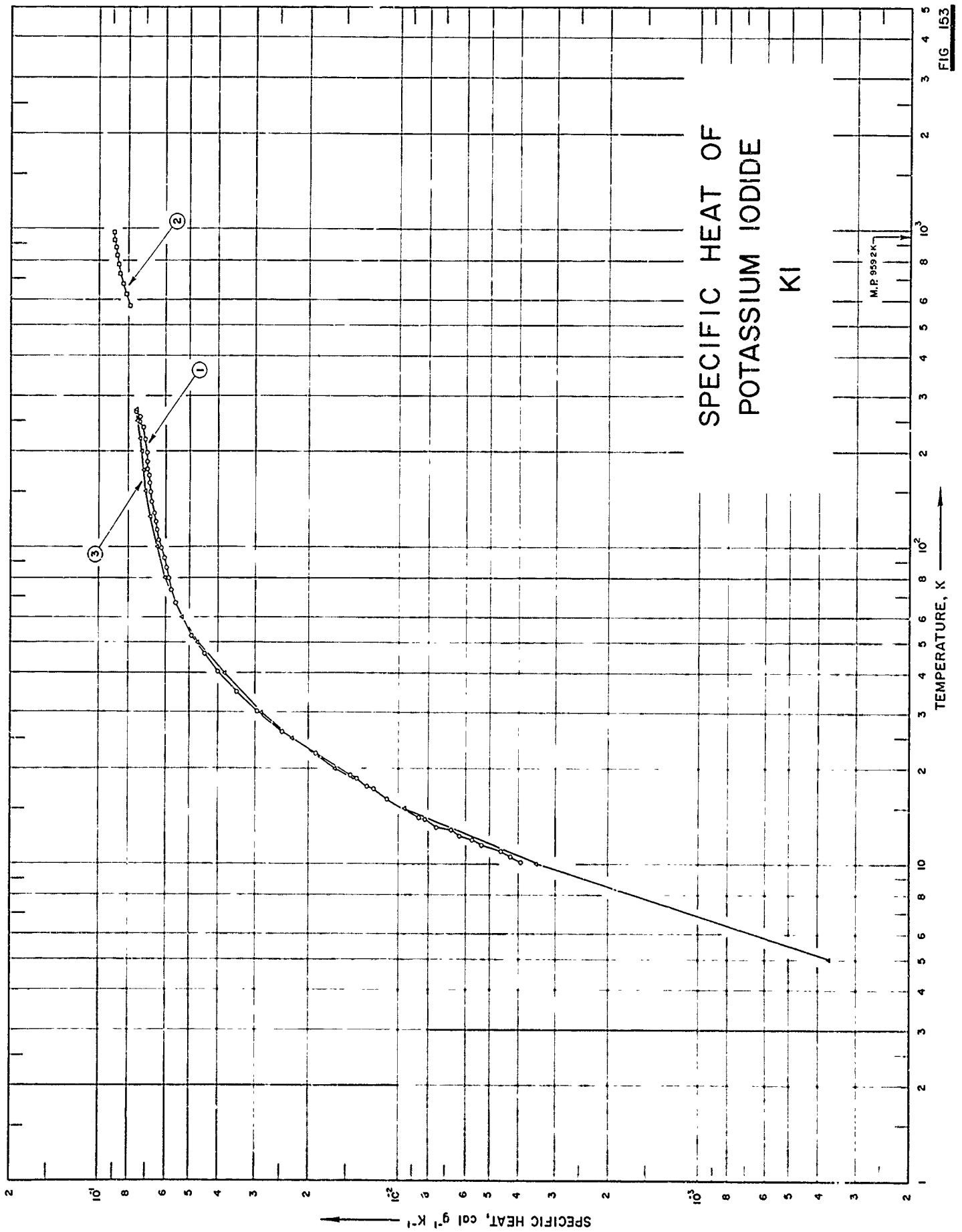

SPECIFICATION TABLE NO. 153 SPECIFY HEAT OF POTASSIUM IODIDE KI

[For Data Reported in Figure and Table No. 153]

Curve No.	Ref. No.	Year	Temp. Range, K	Reported Error, %	Name and Specimen Designation	Composition (weight percent), Specifications and Remarks
1	243	1949	10-288			Sample supplied by the Harshaw Chem. Co; measured under dry helium gas. High purity, optical quality; sample supplied by the Harshaw Chem. Co.
2	244	1953	573-973			
3	245	1957	2.5-270	0.2-2		

FIG. 154

SPECIFIC HEAT OF RUBIDIUM IODIDE RbI

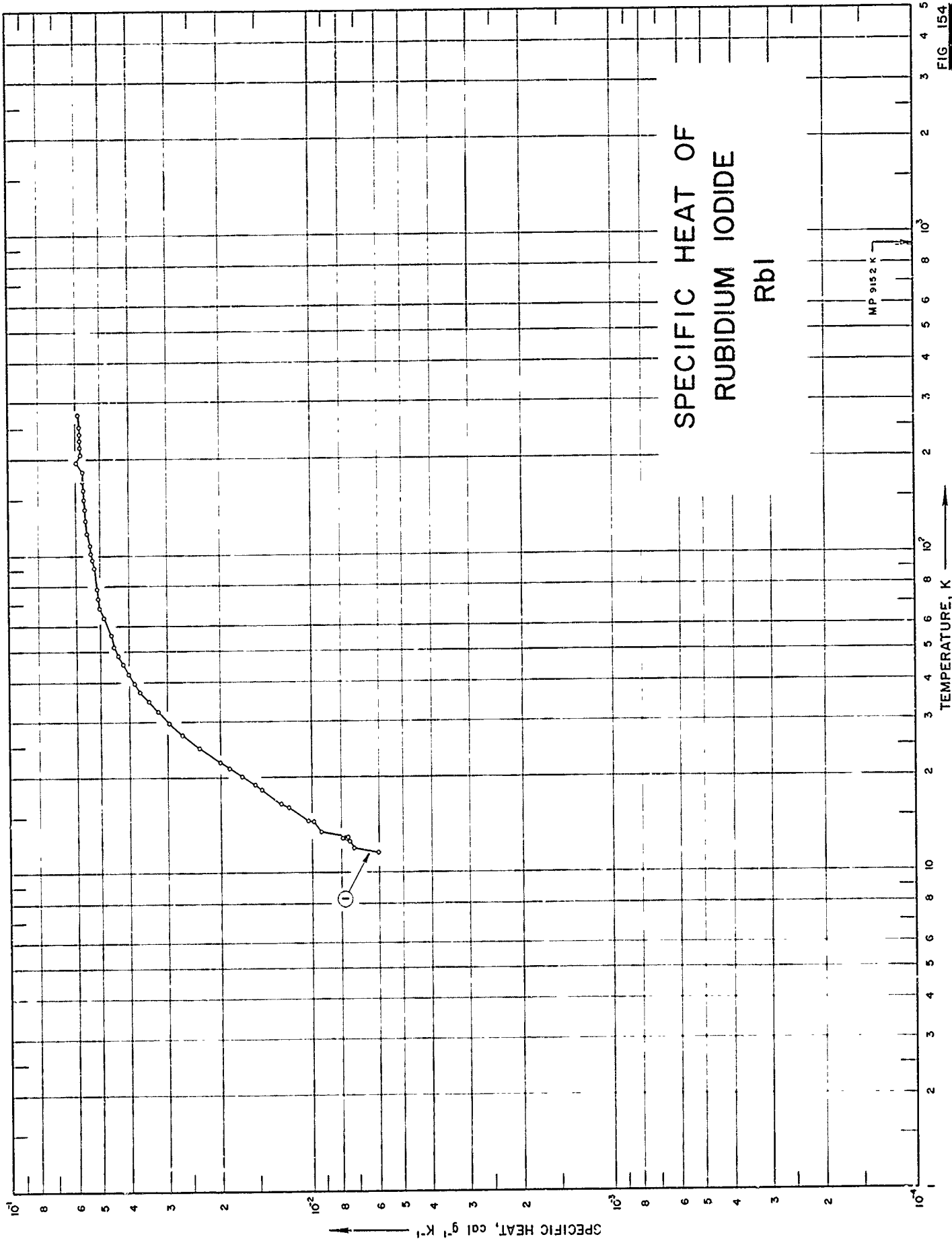

SPECIFICATION TABLE NO. 154 SPECIFIC HEAT OF RUBIDIUM IODIDE RbI

[For Data Reported in Figure and Table No. 154]

Curve No.	Ref. No.	Year	Temp. Range, K	Reported Error, %	Name and Specimen Designation	Composition (weight percent), Specifications and Remarks
1	243	1949	12-277			

DATA TABLE NO. 154 SPECIFIC HEAT OF RUBIDIUM IODIDE RbI

[Temperature, T, K; Specific Heat, C_p , Cal $g^{-1}K^{-1}$]

T	C_p	T	C_p
	CURVE 1		CURVE 1 (cont.)
11.6	6.0×10^{-3}	144.9	5.62×10^{-2}
12.0	7.3	150.3	5.65
12.6	7.5	155.6	5.67*
12.8	7.9	161.2	5.69
12.9	7.6	166.7	5.72*
13.5	9.3	172.2	5.73
14.5	9.89	177.9	5.73*
14.6	1.03×10^{-2}	184.6	5.73
16.2	1.20	189.5	5.75*
16.6	1.27	197.8	6.00
16.7	1.25*	208.4	5.81
18.4	1.47	208.8	5.79*
19.0	1.54	219.3	5.84
20.2	1.71	225.1	5.83†
20.3	1.74*	230.3	5.84
21.4	1.87	235.7	5.85*
22.3	2.01	241.7	5.84
22.8	2.04†	247.9	5.84*
24.8	2.36	254.8	5.85
24.9	2.35	260.5	5.91*
27.3	2.68	276.9	5.91
29.8	2.97		
32.3	3.23		
34.8	3.46		
37.3	3.71		
39.8	3.85		
42.5	4.05		
45.6	4.22		
48.9	4.39		
51.9	4.53		
56.5	4.61		
64.3	4.89		
68.6	5.01		
73.5	5.06		
78.7	5.12		
91.9	5.25		
97.0	5.31		
102.2	5.37		
107.6	5.42		
112.7	5.47*		
117.9	5.52		
123.3	5.54*		
129.0	5.58		
134.4	5.58*		
140.0	5.61		

* Not shown on plot

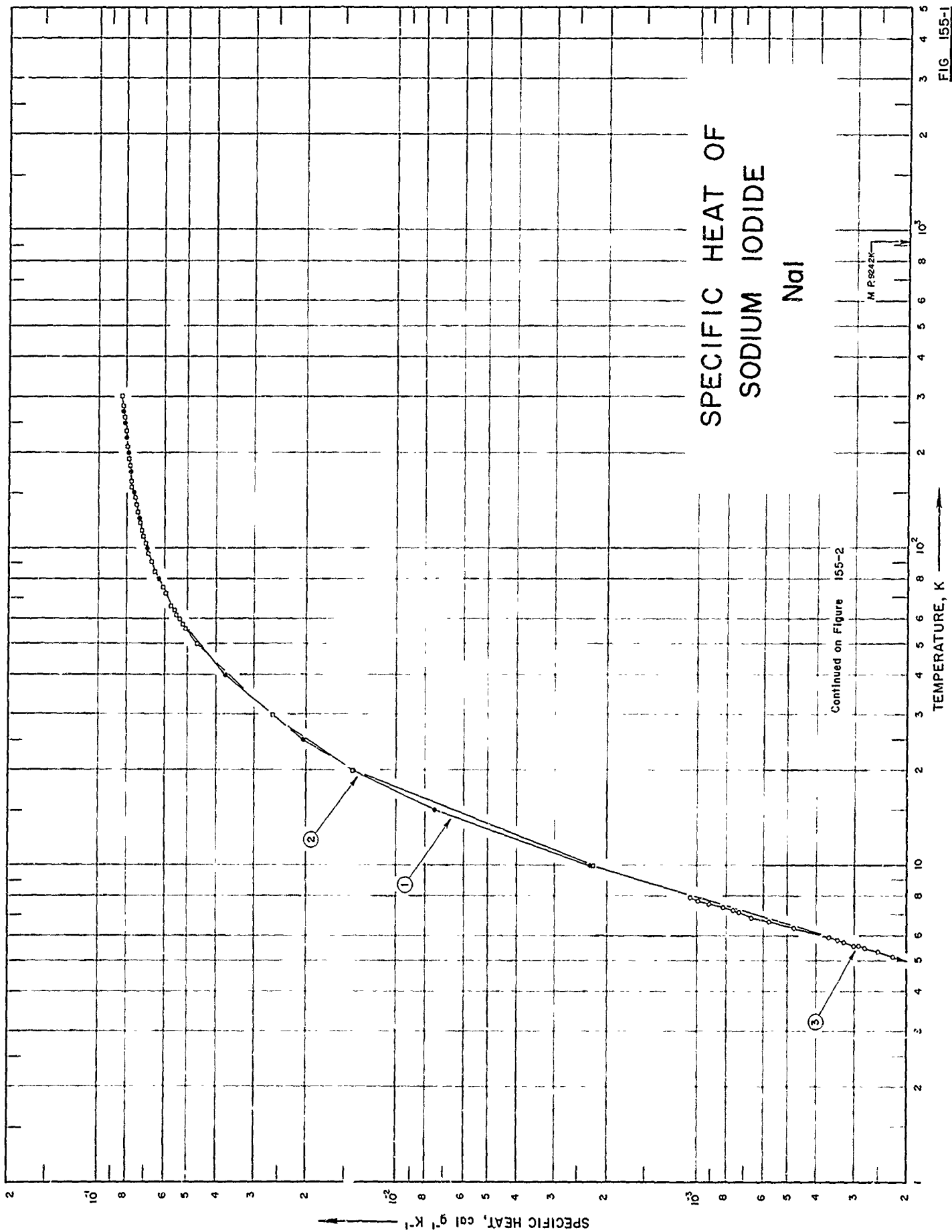
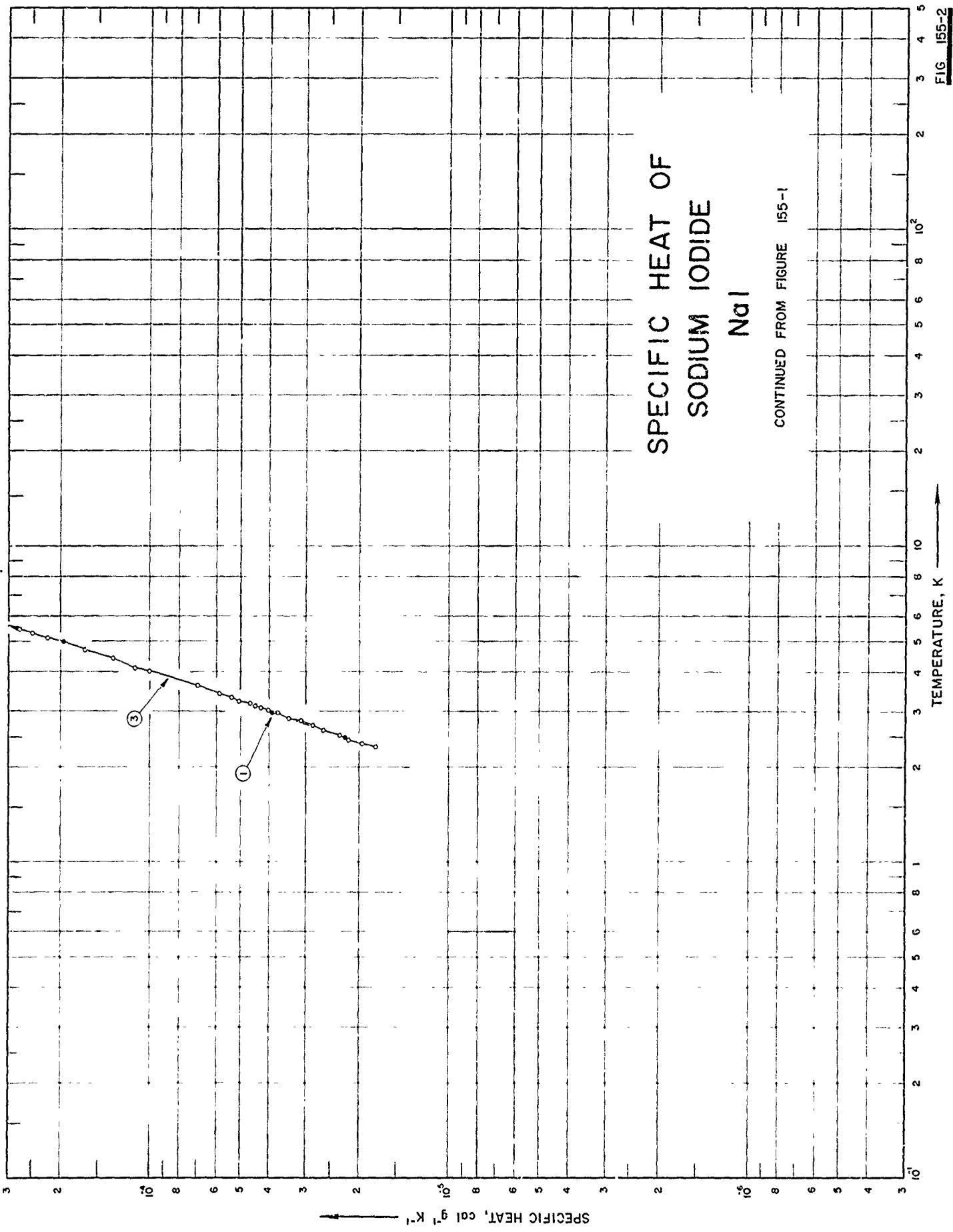

FIG 155-1

SPECIFIC HEAT OF SODIUM IODIDE NaI

CONTINUED FROM FIGURE 155-1



SPECIFIC HEAT, cal g⁻¹ K⁻¹

TEMPERATURE, K

SPECIFICATION TABLE NO. 155 SPECIFIC HEAT OF SODIUM IODIDE NaI

[For Data Reported in Figure and Table No. 155]

Curve No.	Ref. No.	Year	Temp. Range, K	Reported Error, %	Name and Specimen Designation	Composition (weight percent), Specifications and Remarks
1	361	1957	2.5-270	0.2-2		High purity, optical quality; sample supplied by the Harshaw Chem. Co; measured under a helium atmosphere.
2	246	1964	56-301	0.3		99.9889 NaI, 0.001-0.01 K, 0.0001-0.001 Ca, and 0.001 Mg; melted under an atmosphere of dry hydrogen.
3	337	1960	2.3-7.9			High purity, optically clear single crystal; sample supplied by the Harshaw Chemical Co; measured in high vacuum.

DATA TABLE NO. 155 SPECIFIC HEAT OF SODIUM IODIDE NaI

[Temperature, T, K; Specific Heat, Cp, Cal g⁻¹K⁻¹]

T	CURVE 1		CURVE 2 (cont.)		CURVE 2 (cont.)		CURVE 3 (cont.)	
	T	C _p	T	C _p	T	C _p	T	C _p
2.5	2.242 x 10 ⁻⁵	117.12	7.189 x 10 ^{-2*}	256.82	8.166 x 10 ^{-2*}	4.728	1.665 x 10 ⁻⁴	
3	3.916	120.67	7.248	259.14	8.174	4.752	1.660	
5	1.961 x 10 ⁻⁴	124.19	7.299*	262.12	8.187*	4.958	1.955*	
10	2.236 x 10 ⁻³	127.66	7.352*	264.79	8.200*	4.980	1.934*	
15	7.472	131.09	7.400	267.79	8.207*	5.149	2.229	
20	1.409 x 10 ⁻²	134.50	7.442*	270.80	8.216*	5.181	2.221*	
25	2.060	137.88	7.449	274.31	8.228*	5.318	2.492	
30	2.664*	140.99	7.509*	278.04	8.240*	5.466	2.768	
40	3.753	144.47	7.552	281.67	8.256	5.581	2.909	
50	4.628*	148.03	7.585*	285.28	8.272*	5.585	3.003	
60	5.336	151.61	7.620*	288.86	8.280*	5.707	3.250	
80	6.289	155.17	7.649*	292.44	8.291*	5.738	3.209*	
100	6.861	158.69	7.682*	295.05	8.297*	5.919	3.400	
125	7.305	163.12	7.716	297.70	8.306*	5.910	3.634	
150	7.695	165.67	7.734	301.16	8.309	6.390	4.748	
175	7.802	167.51	7.746			6.678	5.746	
200	7.949	169.11	7.760*			6.834	6.057	
225	8.069	170.94	7.771			6.980	6.634*	
250	8.169	174.40	7.794			7.114	7.252	
270	8.246	177.89	7.819*			7.246	7.532	
		181.35	7.844			7.396	8.186	
		184.85	7.869*			7.584	9.106	
		188.42	7.881*			7.752	9.960	
		192.03	7.901			7.909	1.056 x 10 ⁻³	
		195.61	7.926*					
56.32	5.116 x 10 ⁻⁴	196.81	7.928					
57.98	5.221	196.81	7.928					
58.88	5.242*	200.34	7.947					
61.87	5.468	203.86	7.961*					
64.05	5.591	207.36	7.976*					
66.65	5.727	210.85	7.992					
68.40	5.856	214.31	8.007*					
72.21	5.982	217.36	8.018*					
75.15	6.105	220.78	8.030*					
78.25	6.322*	224.19	8.047*					
81.41	6.356*	228.02	8.060*					
84.50	6.467	228.34	8.062*					
87.66	6.570*	231.40	8.071*					
90.62	6.645	235.02	8.085					
93.63	6.727*	238.33	8.101*					
96.87	6.805	238.96	8.105*					
100.91	6.891*	242.28	8.112*					
104.00	6.956	246.89	8.126*					
107.13	7.017*	250.98	8.145*					
109.85	7.072	252.79	8.149*					
110.76	7.084*	255.20	8.160*					
113.51	7.138							

CURVE 3

CURVE 2 (cont.)

CURVE 1

* Not shown on plot

FIGURE SHOWS ONLY 1 OF THE CURVES REPORTED IN TABLE

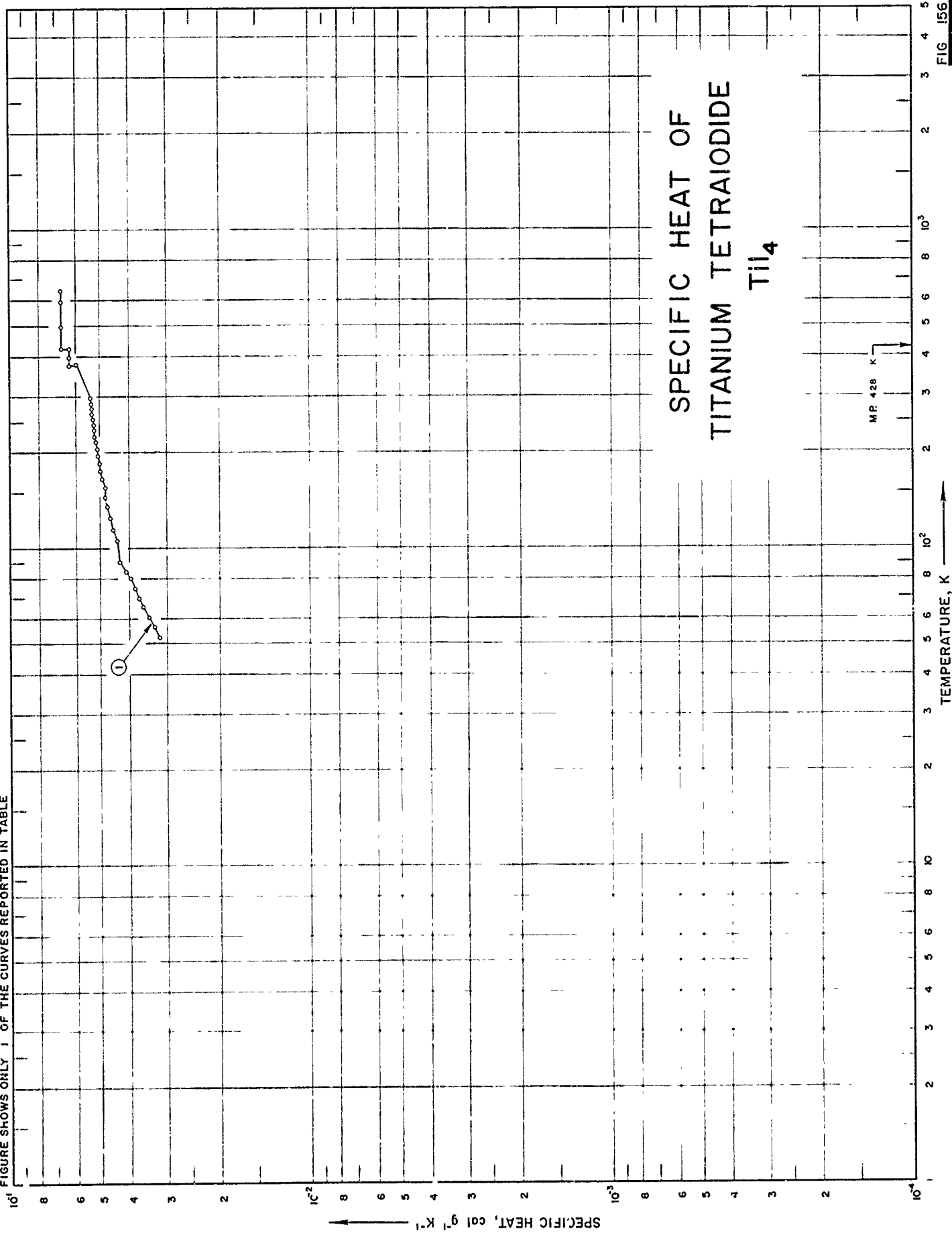

FIG. 156

SPECIFICATION TABLE NO. 156 SPECIFIC HEAT OF TITANIUM TETRAIODIDE TiI_4

[For Data Reported in Figure and Table No. 156]

Curve No.	Ref. No.	Year	Temp. Range, K	Reported Error, %	Name and Specimen Designation	Composition (weight percent), Specifications and Remarks
1	247	1961	298-650			
2	247	1961	52-297			90.87 I, 8.68 TI and 0.48 Cl, (91.38 and 8.62 theo).

DATA TABLE NO. 156 SPECIFIC HEAT OF TITANIUM TETRAIODIDE TiI_4
 [Temperature, T, K; Specific Heat, C_p , Cal $g^{-1}K^{-1}$]

T	C_p
<u>CURVE 1</u>	
298.15	5.404×10^{-2}
300	5.418*
α 379	6.001
β 379	6.372
400	6.372
β 428	6.572
(1) 428	6.732
500	6.732
600	6.732
650	6.732
<u>CURVE 2</u>	
52.40	3.197×10^{-2}
56.47	3.319
60.74	3.465
65.37	3.618
69.93	3.746
74.77	3.861
80.79	3.993
84.87	4.074
90.07	4.174
105.79	4.417
115.15	4.549
125.08	4.660
135.96	4.763
145.69	4.849
155.62	4.921
165.97	4.981
175.93	5.038
186.01	5.089
195.90	5.127
206.18	5.154
216.40	5.202
226.26	5.231
236.47	5.254
246.15	5.280
256.72	5.305
266.60	5.334
276.68	5.359
286.90	5.388
296.89	5.400*

* Not shown on plot

FIG. 157

SPECIFIC HEAT OF
URANIUM TETRAIODIDE
 U_4I_{14}

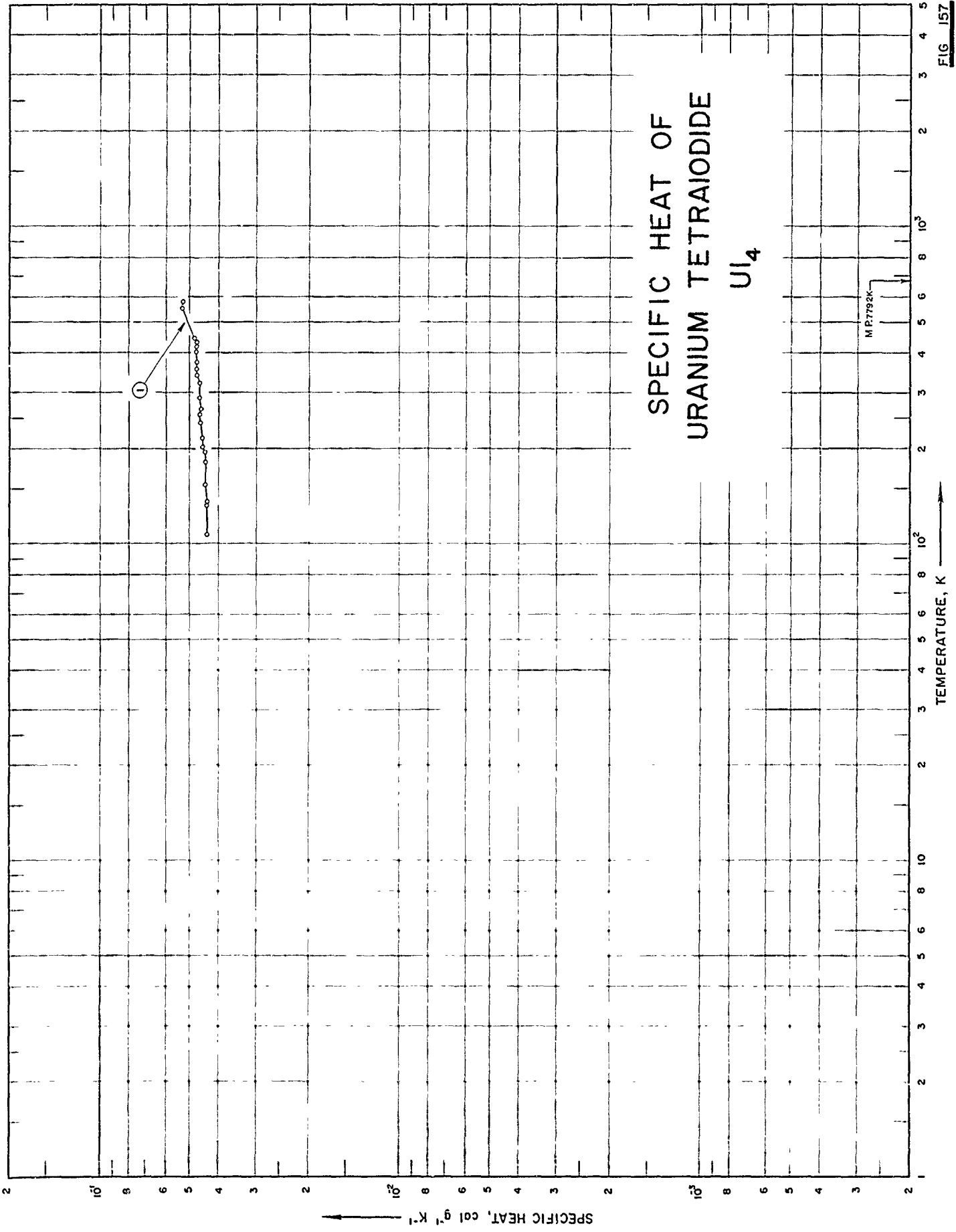

SPECIFICATION TABLE NO. 157 SPECIFIC HEAT OF URANIUM TETRAIODIDE U_4I_{14}

[For Data Reported in Figure and Table No. 157]

Curve No.	Ref. No.	Year	Temp. Range, K	Reported Error, %	Name and Specimen Designation	Composition (weight percent), Specifications and Remarks
1	325	1959	197-597			0.07 impurities, mainly Fe and Si; heat treated.

DATA TABLE NO. 157 SPECIFIC HEAT OF URANIUM TETRAIODIDE U₄
 [Temperature, T, K; Specific Heat, C_p, Cal g⁻¹K⁻¹]

T	C _p
	CURVE 1
107	4.391 x 10 ⁻²
133	4.404
138	4.391
154	4.419
181	4.477
196	4.535
203	4.520
216	4.553
241	4.606
258	4.635
268	4.606
290	4.649
299	4.578*
323	4.678
333	4.691*
341	4.721
357	4.663
357	4.734*
375	4.706
393	4.734*
405	4.706
412	4.777*
419	4.753*
420	4.721
426	4.706*
432	4.749*
435	4.736
438	4.792*
439	4.807*
444	4.764*
(s)449	4.826
(l)551	5.308
552	5.308*
562	5.280*
563	5.323*
570	5.381*
571	5.323*
583	5.280
589	5.327*
593	5.280*
597	5.308*

* Not shown on plot

FIG. 158

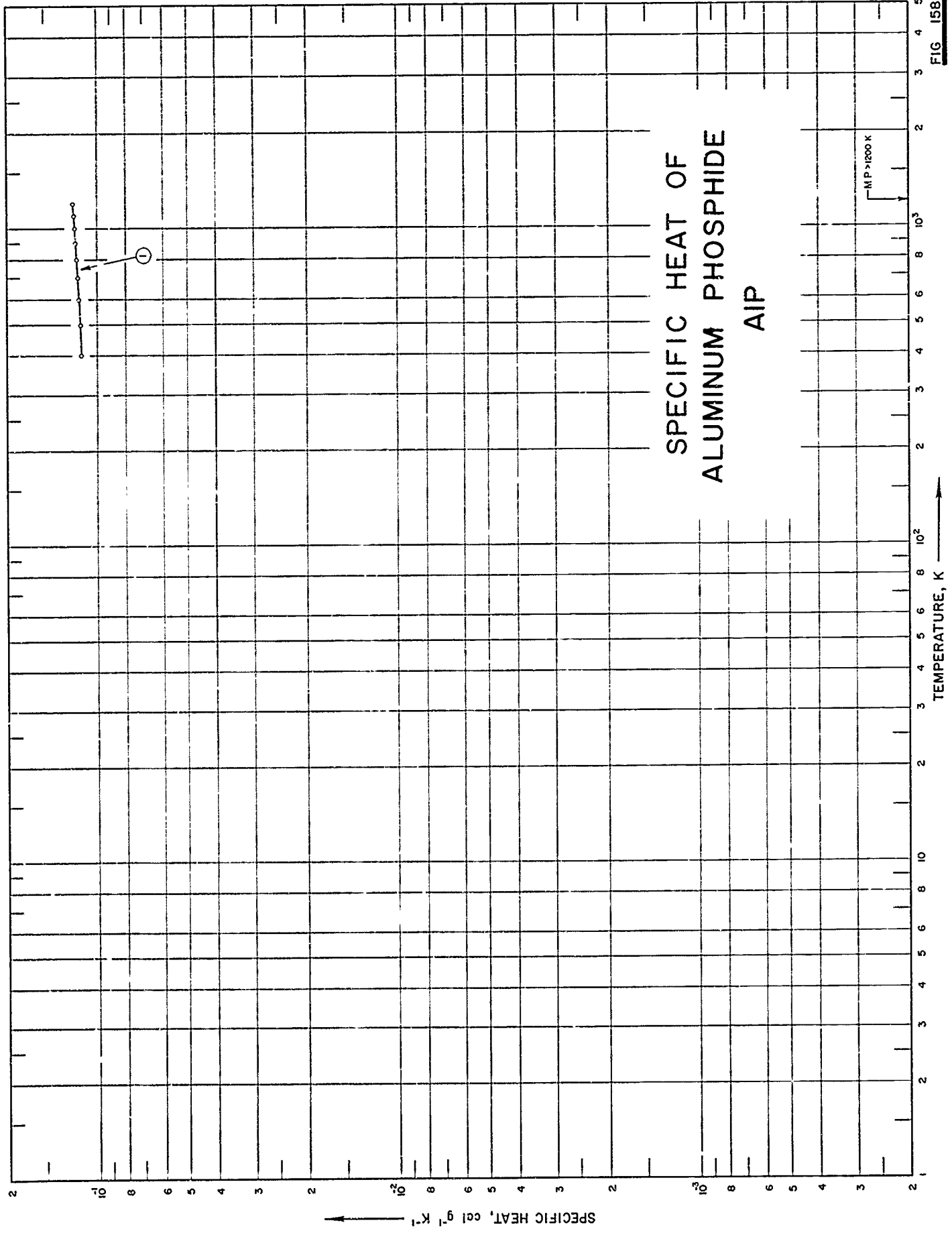

SPECIFICATION TABLE NO. 158 SPECIFIC HEAT OF ALUMINUM PHOSPHIDE AIP

[For Data Reported in Figure and Table No. 158]

Curve No.	Ref. No.	Year	Temp. Range, K	Reported Error, %	Name and Specimen Designation	Composition (weight percent), Specifications and Remarks
1	157	1963	400-1200			~99.99 AIP.

DATA TABLE NO. 158 SPECIFIC HEAT OF ALUMINUM PHOSPHIDE AIP
[Temperature, T, K; Specific Heat, C_p , Cal $g^{-1}K^{-1}$]

T	C_p
<u>CURVE 1</u>	
400	1.141 x 10 ⁻¹
500	1.149
600	1.157
700	1.166
800	1.174
900	1.182
1000	1.190
1100	1.198
1200	1.21

* Not shown on plot

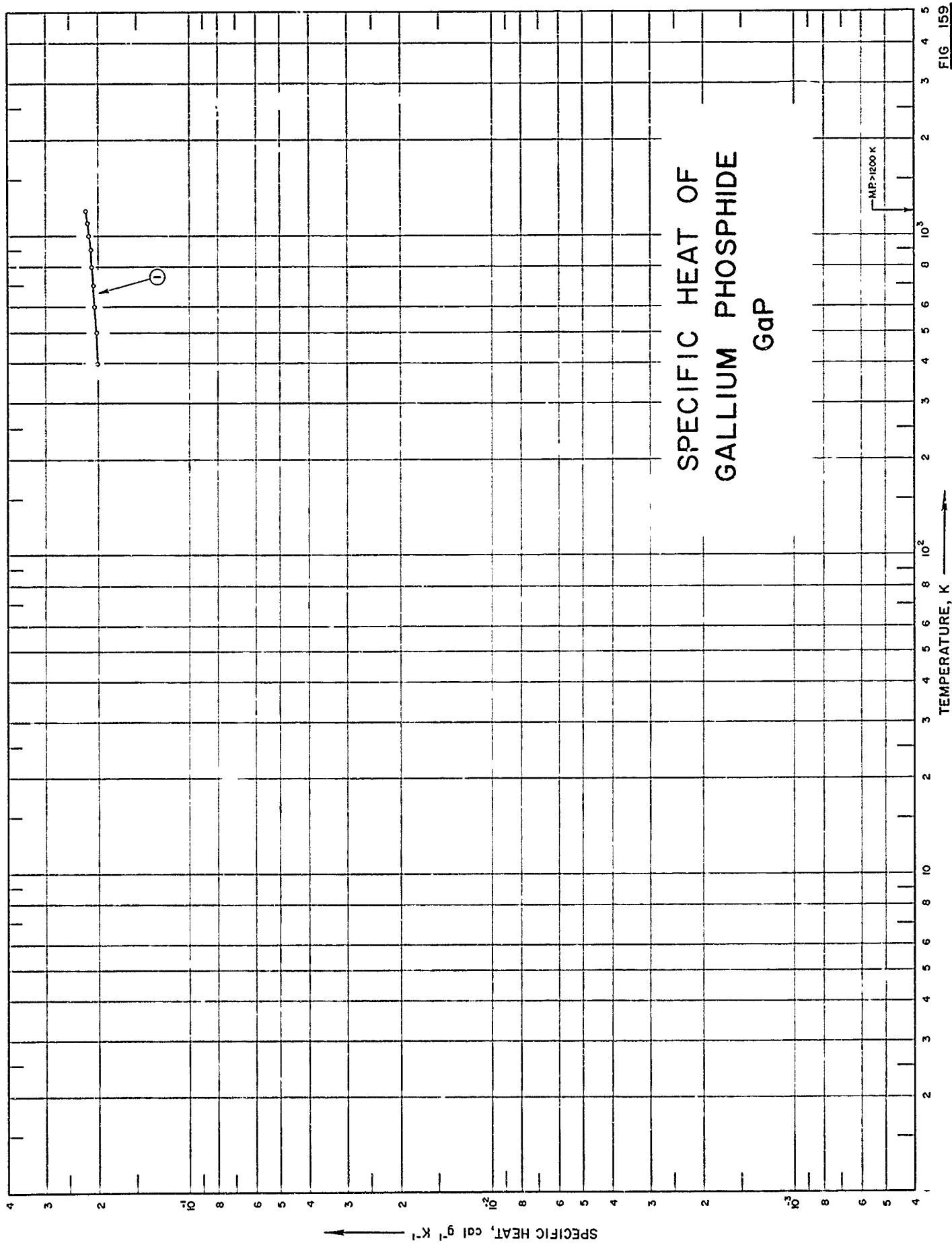

FIG. 159

SPECIFICATION TABLE NO. 159 SPECIFIC HEAT OF GALLIUM PHOSPHIDE GaP

[For Data Reported in Figure and Table No. 159]

Curve No.	Ref. No.	Year	Temp. Range, K	Reported Error, %	Name and Specimen Designation	Composition (weight percent), Specifications and Remarks
1	157	1963	400-1200			~99.99 GaP.

DATA TABLE NO. 159 SPECIFIC HEAT OF GALLIUM PHOSPHIDE GaP
[Temperature, T, K; Specific Heat, C_p , Cal $g^{-1}K^{-1}$]

T	C_p
	<u>CURVE 1</u>
400	2.020×10^{-1}
500	2.044
600	2.068
700	2.091
800	2.115
900	2.139
1000	2.162
1100	2.186
1200	2.210

SPECIFIC HEAT OF INDIUM PHOSPHIDE InP

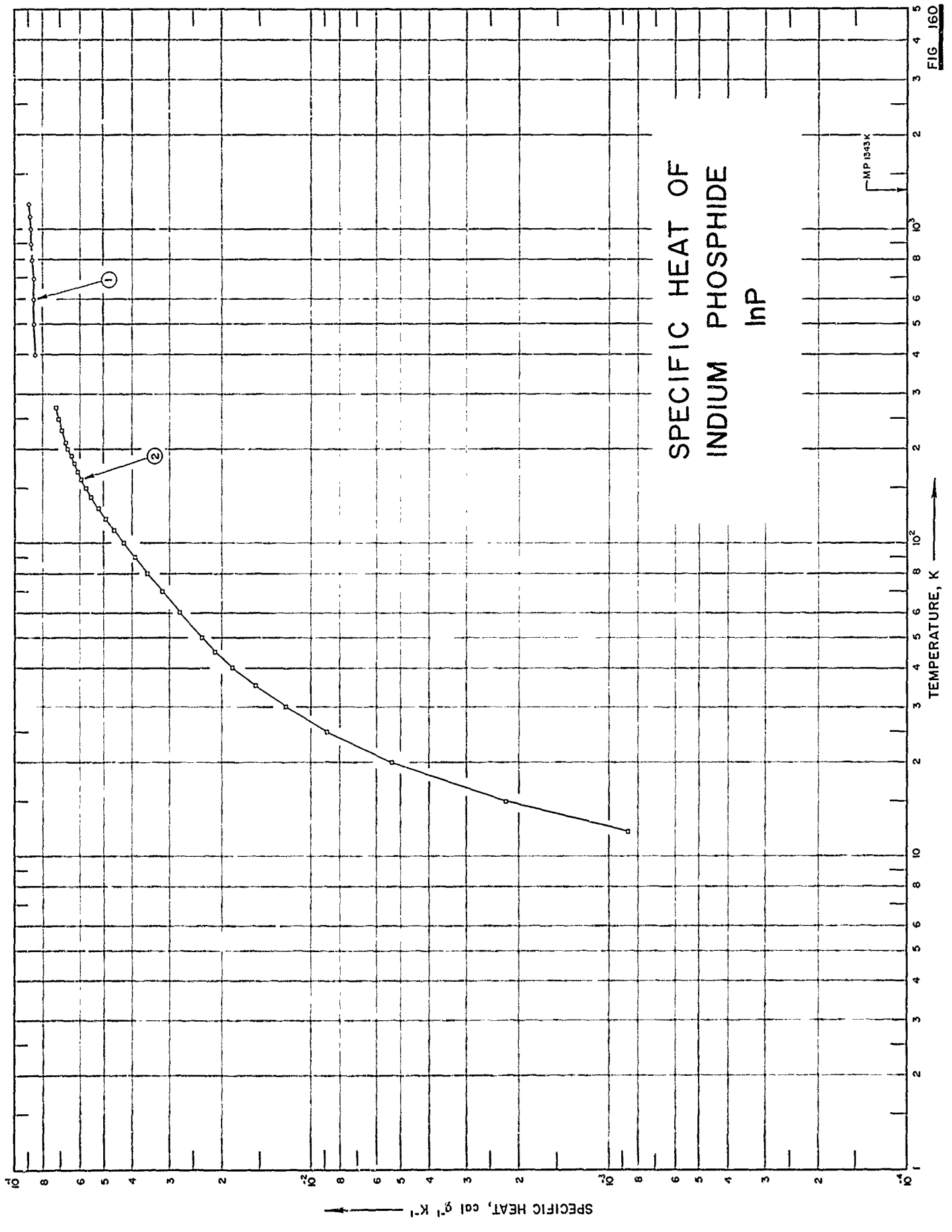

FIG. 160

SPECIFICATION TABLE NO. 160 SPECIFIC HEAT OF INDIUM PHOSPHIDE InP

[For Data Reported in Figure and Table No. 160]

Curve No.	Ref. No.	Year	Temp. Range, K	Reported Error, %	Name and Specimen Designation	Composition (weight percent), Specifications and Remarks
1	157	1963	400-1200			
2	156	1963	12-273.2	±2.0		~99.99 InP.

DATA TABLE NO. 160 SPECIFIC HEAT OF INDIUM PHOSPHIDE InP
 [Temperature, T, K; Specific Heat, C_p , Cal $g^{-1}K^{-1}$]

T	C_p
<u>CURVE 1</u>	
400	8.522×10^{-2}
500	8.578
600	8.634
700	8.689
800	8.745
900	8.801
1000	8.856
1100	8.912
1200	8.968
<u>CURVE 2</u>	
12	8.6×10^{-4}
15	2.22×10^{-3}
20	5.32
25	8.89
30	1.22×10^{-2}
35	1.547
40	1.845
45	2.113
50	2.346
60	2.775
70	3.180
80	3.567
90	3.940
100	4.296
110	4.623
120	4.932
130	5.226
140	5.504
150	5.748
160	5.956
170	6.137
180	6.303
190	6.462
200	6.609
210	6.745
220	6.869*
230	6.955
240	7.044*
250	7.124
260	7.202*
270	7.280*
273.2	7.298

* Not shown on plot

FIG. 161

SPECIFIC HEAT OF IRON DISELENIDE FeSe₂

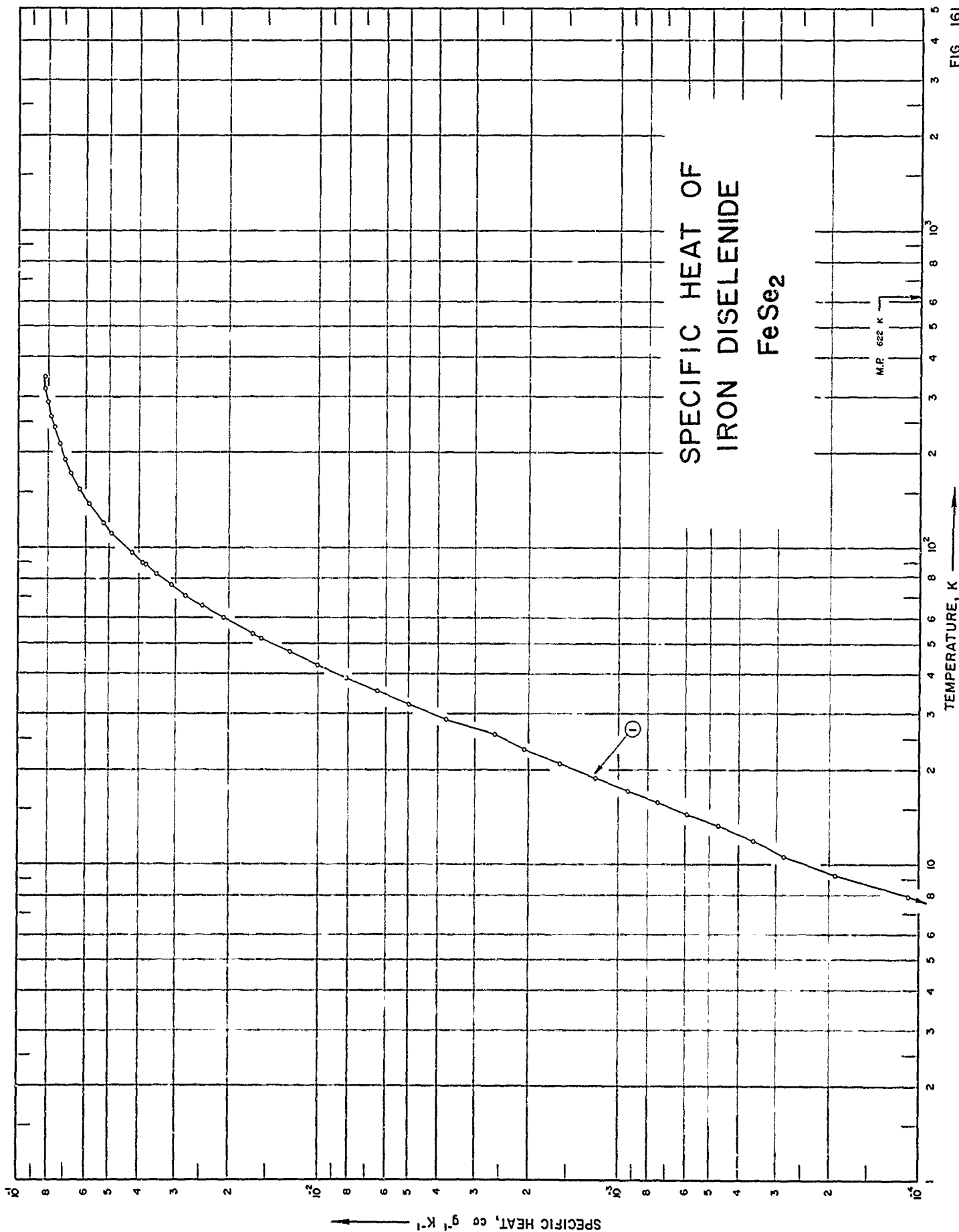

PRECEDING PAGE BLANK-NOT FILMED

SPECIFICATION TABLE NO. 161 SPECIFIC HEAT OF IRON DISELENIDE FeSe_2

[For Data Reported in Figure and Table No. 161]

Curve No.	Ref. No.	Year	Temp. Range, K	Reported Error, %	Name and Specimen Designation	Composition (weight percent), Specifications and Remarks
1	214	1962	5-347	0.1-5		<p>Impurities: ~0.01 Ni, Si, and ~0.001 Mn, high purity selenide impurities: 0.0002 Cl, 0.0008 Fe, 0.0004 Na, 0.0003 K, and 0.0012 non-volatile matter; orthorhombic marcasite-type structure; made from high purity iron and selenium; heated slowly to 1000 C in an evacuated and sealed silica tube for 2 hrs and cooled to room temp; heated at 340 C for one month and then cooled slowly to room temperature during a period of 1 month.</p>

DATA TABLE NO. 161 SPECIFIC HEAT OF IRON DISELENIDE FeSe_2
 [Temperature, T, K; Specific Heat, C_p , Cal $\text{g}^{-1} \text{K}^{-1}$]

T	C_p	T	C_p
CURVE 1		CURVE 1 (cont.)	
Series 1			
53.66	1.669×10^{-2}	163.26	6.527×10^{-2} *
60.13	2.082	172.22	6.710
65.85	2.455	181.34	6.882*
71.07	2.781	190.93	7.042
76.51	3.115	200.38	7.164*
82.66	3.492	203.92	7.230*
89.61	3.885	213.37	7.354
Series 2			
5.36	3.742×10^{-6} *	222.97	7.470*
6.81	7.110*	232.35	7.574*
7.91	1.095×10^{-4}	241.81	7.681
9.24	1.913	251.35	7.765*
10.59	2.821	260.79	7.845
11.96	3.593	270.31	7.929*
13.23	4.697	279.94	8.009*
14.47	5.932	289.43	8.074
15.74	7.447	298.68	8.158*
17.15	9.370	308.07	8.214*
18.81	1.205×10^{-3}	317.67	8.233
20.80	1.582	327.45	8.224*
23.12	2.091	337.48	8.257*
25.80	2.697	347.46	8.299
28.81	3.787		
32.05	5.005		
35.43	6.451		
38.97	8.168		
42.73	1.013×10^{-2}		
47.10	1.264		
51.96	1.560		
Series 3			
87.69	3.776×10^{-2}		
96.27	4.230		
104.45	4.609*		
112.32	4.950		
120.26	5.266		
128.67	5.570*		
137.28	5.872		
145.74	6.094*		
154.32	6.318		

* Not shown on plot

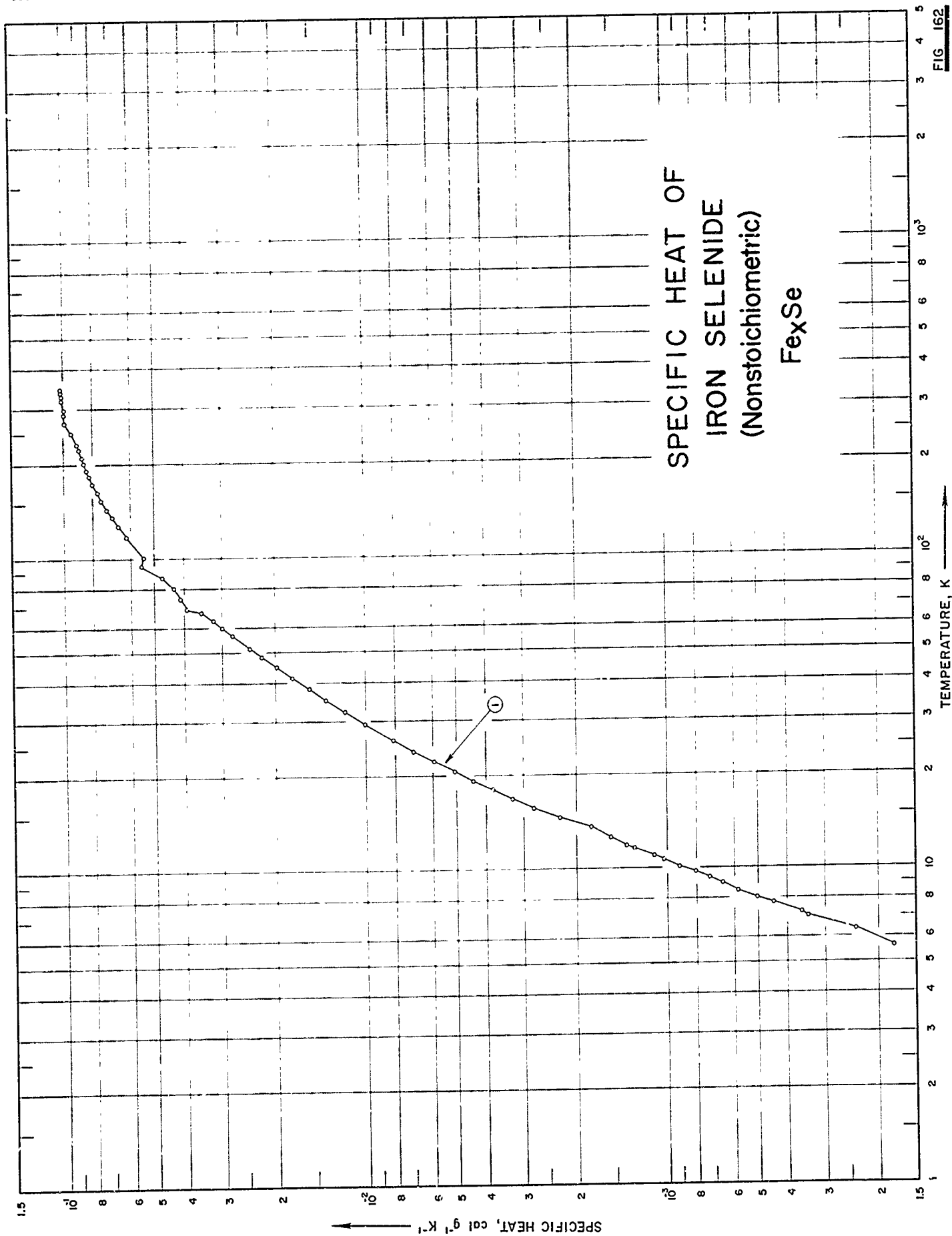

FIG 162

SPECIFICATION TABLE NO. 162 SPECIFIC HEAT OF IRON SELENIDE (nonstoichiometric) Fe_xSe

[For Data Reported in Figure and Table No. 162]

Curve No.	Ref. No.	Year	Temp. Range, K	Reported Error, %	Name and Specimen Designation	Composition (weight percent), Specifications and Remarks
1	226	1959	6-347	0.1-1.0		99.979 Fe, 0.021 Se, 0.01 Ni, 0.01 Si, and 0.001 Mn; fused for 4 hrs at 1050 C; cooled to room temperature; fragmented under dry nitrogen; homogenized at 350 C for 30 days and cooled to room temperature over 30 days.

DATA TABLE NO. 162 SPECIFIC HEAT OF IRON SELENIDE Fe_xSe (nonstoichiometric)[Temperature, T, K; Specific Heat, C_p , Cal $\text{g}^{-1} \text{K}^{-1}$]

T	C_p	T	C_p
<u>CURVE 1</u>		<u>CURVE 1 (cont.)</u>	
Series 1		Series 2 (cont.)	
51.58	2.440×10^{-2}	11.97	1.370×10^{-3}
56.71	2.787	Series 3	
63.13	3.226	5.60	1.787×10^{-4}
69.08	3.954	6.38	2.382
74.43	4.176	7.25	3.573
80.50	4.346	8.06	5.062
87.17	4.742	8.91	6.551
94.34	5.577	9.76	8.188
101.47	5.488	10.67	1.027×10^{-3}
109.61	5.882*	11.62	1.280
118.34	6.268	12.63	1.548
127.34	6.628	13.65	1.897
136.2*	6.950	14.67	2.297
144.93	7.250	15.77	2.775
154.15	7.526	16.89	3.257
163.86	7.798	18.07	3.799
173.52	8.042	19.29	4.402
182.90	8.249	20.65	5.080
192.20	8.467	22.30	5.952
201.68	8.641	24.17	6.972
211.17	8.799	26.26	8.146
223.65	9.014	29.47	1.006×10^{-2}
232.96	9.126	32.30	1.179
242.36	9.300*	35.32	1.368
251.68	9.427	38.30	1.559
261.19	9.540*	41.49	1.764
270.80	9.658*	45.04	1.998
280.33	9.765*	48.40	2.226
289.71	9.868	54.52	2.651*
299.16	9.963	60.40	3.003
308.73	1.006×10^{-1}	64.63	3.324*
318.32	1.015	67.59	3.522
327.94	1.023	70.56	3.706*
337.51	1.031	73.53	3.908*
347.23	1.039	76.75	4.107*
Series 2		80.36	4.338*
7.02	3.424×10^{-4}	83.94	4.551*
7.77	4.466	87.50	4.761*
8.48	5.806	91.11	4.955*
9.31	7.295	94.92	5.154*
10.15	9.081	99.11	5.365*
11.03	1.102×10^{-3}	103.51	5.584*

* Not shown on plot

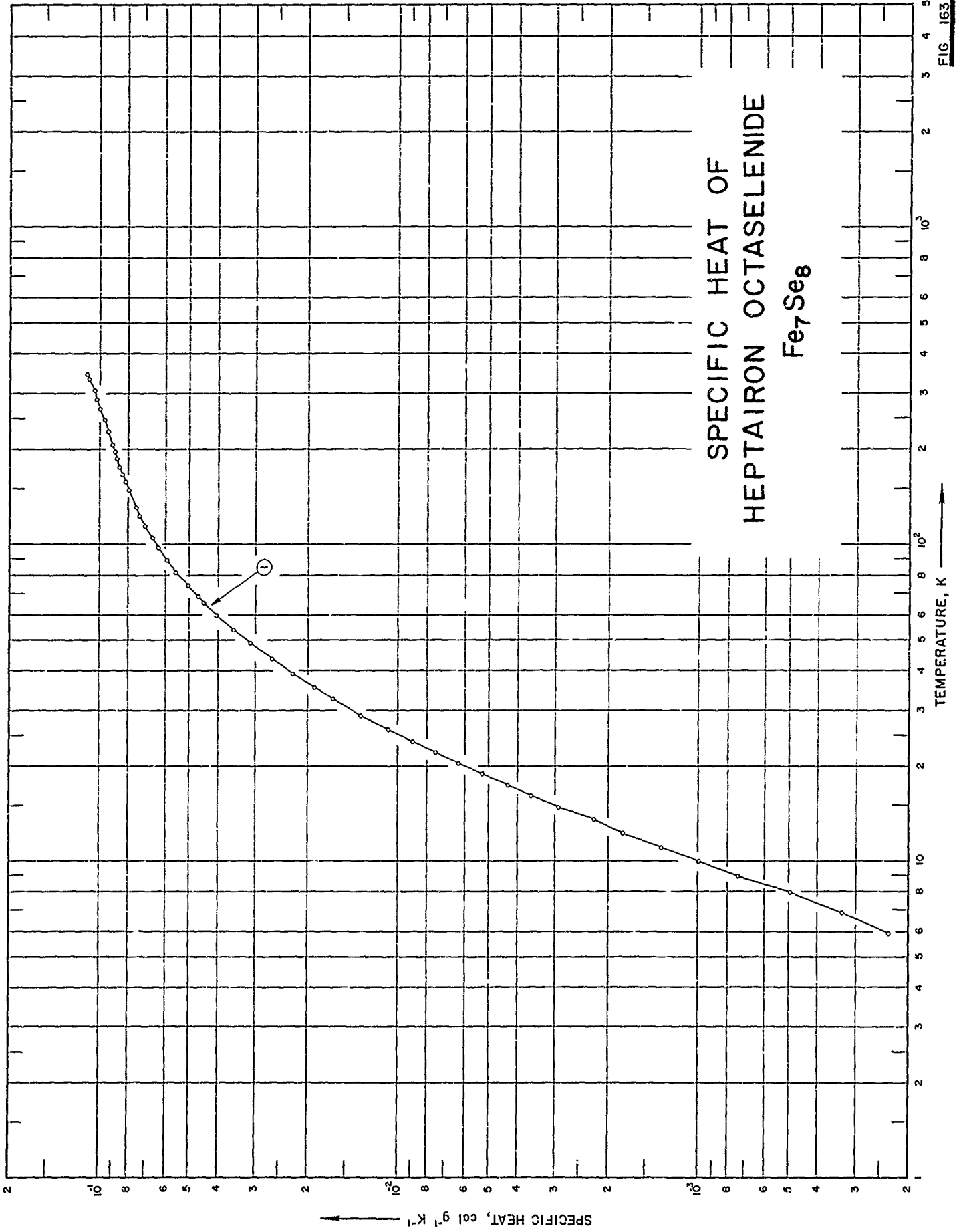

SPECIFICATION TABLE NO. 163 SPECIFIC HEAT OF HEPTAIRON OCTASELENIDE Fe_7Se_8

[For Data Reported in Figure and Table No. 163]

Curve No.	Ref. No.	Year	Temp. Range, K	Reported Error, %	Name and Specimen Designation	Composition (weight percent), Specifications and Remarks
1	226	1959	6-345	0.1-1.0		99.979 Fe_7Se_8 , 0.01 Ni, 0.01 Si, and 0.001 Mn; fused for 4 hrs at 1050 C; cooled to room temperature; fragmented under dry nitrogen; homogenized at 350 C for 30 days and cooled to room temperature over 30 days.

DATA TABLE NO. 163 SPECIFIC HEAT OF HEPTAIRON OCTASELENIIDE Fe_7Se_8 [Temperature, T, K; Specific Heat, C_p , Cal $\text{g}^{-1}\text{K}^{-1}$]

T	C_p	T	C_p
	CURVE 1		CURVE 1 (cont.)
5.91	2.347×10^{-4}	248.51	9.636×10^{-2}
6.86	3.373	258.43	9.770*
7.92	4.987	268.37	9.911
8.90	7.334	278.34	1.005×10^{-1} *
9.95	9.974	288.43	1.020
11.11	1.335×10^{-3}	298.72	1.034*
12.35	1.789	308.98	1.048
13.58	2.325	319.12	1.064*
14.84	2.925	331.24	1.084
16.13	3.607	344.70	1.106
17.45	4.385		
18.84	5.254		
20.24	6.301		
22.02	7.505		
23.91	8.959		
26.14	1.078×10^{-2}		
28.86	1.312		
32.66	1.656		
35.41	1.914		
39.01	2.253		
43.23	2.644		
48.46	3.121		
53.75	3.576		
59.40	4.031		
65.61	4.493		
68.25	4.673		
74.25	5.057		
81.67	5.524		
89.51	5.952		
97.40	6.317		
105.92	6.675		
114.67	7.001		
123.20	7.386		
131.46	7.529		
139.76	7.754*		
148.64	7.972		
152.28	8.060*		
158.23	8.184		
166.24	8.341		
176.54	8.533		
187.24	8.724		
197.70	8.891		
207.95	9.047		
218.00	9.199*		
228.16	9.341		
238.43	9.495*		

* Not shown on plot

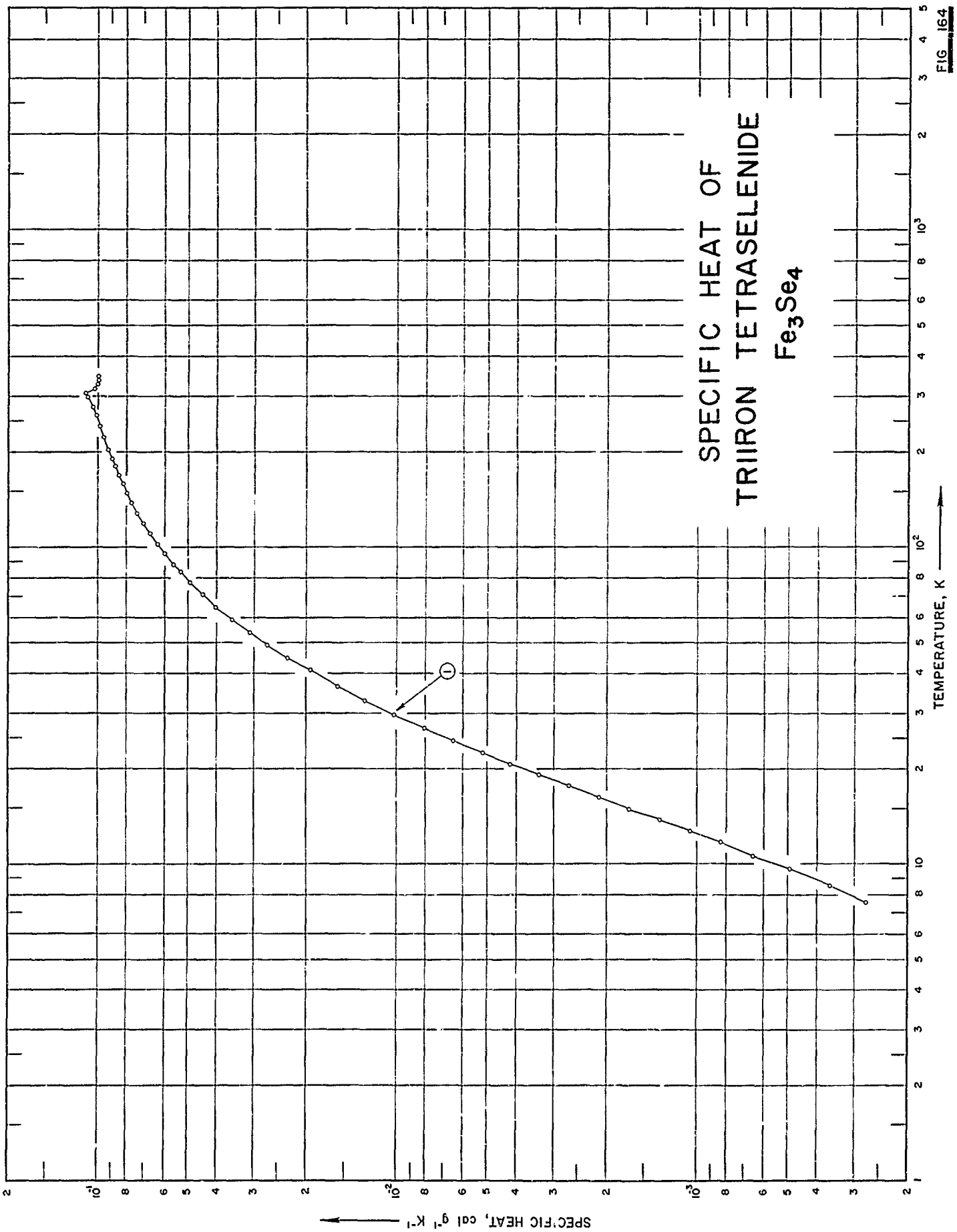

FIG. 164

SPECIFICATION TABLE NO. 164 SPECIFIC HEAT OF TRIRON TETRASELENIDE Fe_3Se_4

[For Data Reported in Figure and Table No. 164]

Curve No.	Ref. No.	Year	Temp. Range, K	Reported Error, %	Name and Specimen Designation	Composition (weight percent), Specifications and Remarks
1	226	1959	6-348			99.979 Fe_3Se_4 , 0.01 Ni, 0.01 Si, and 0.001 Mn; fused for 4 hrs at 1050 C; cooled to room temperature; fragmented under dry nitrogen atmosphere, homogenized at 350 C for 30 days and cooled to room temperature over 30 days.

DATA TABLE NO. 164 SPECIFIC HEAT OF TRIIRON TETRASELENIDE Fe_3Se_4 [Temperature, T, K; Specific Heat, C_p , Cal $\text{g}^{-1} \text{K}^{-1}$]

T	C_p	T	C_p
CURVE 1		CURVE 1 (cont.)	
Series 1			
81.54	5.243×10^{-2} *	17.62	2.688×10^{-3}
88.16	5.646	19.11	3.378
95.16	6.012	20.69	4.208
102.57	6.367	22.44	5.223
110.73	6.735	24.45	6.516
119.66	7.084	26.82	8.164
129.18	7.425	29.55	1.025×10^{-2}
138.85	7.719	32.71	1.281
148.51	8.029	36.30	1.588
159.09	8.299	40.51	1.959
169.51	8.553	44.84	2.346
180.21	8.781	49.04	2.724
190.88	8.995	53.74	3.135
194.78	9.073*	59.00	3.579
204.34	9.228	64.70	4.047
213.76	9.414*	70.75	4.463
223.01	9.557	77.06	4.930
232.23	9.700*	83.85	5.376
241.53	9.852	274.20	1.035×10^{-1} *
250.85	9.996*	283.64	1.053^*
260.04	1.013×10^{-1}	291.43	1.070^*
269.14	1.028^*	297.63	1.088^*
278.38	1.044	301.85	1.099^*
287.76	1.064^*	304.07	1.105^*
297.22	1.089	305.72	1.110^*
306.81	1.102	306.83	1.107^*
316.74	1.026	307.93	1.102^*
327.01	1.001	310.14	1.094^*
337.29	9.997×10^{-2}	311.24	1.078^*
347.55	9.988	312.33	1.063^*
Series 2			
5.57	1.303×10^{-4} *	313.42	1.047^*
6.70	2.027^*	314.52	1.035^*
7.58	2.751	316.19	1.022^*
8.53	3.620	318.42	1.012^*
9.62	4.923	320.66	1.007^*
10.68	6.516	322.91	1.004^*
11.72	8.398	325.16	1.002^*
12.77	1.067×10^{-3}	329.10	9.996×10^{-2} *
13.85	1.335	336.77	9.981^*
14.99	1.696	346.44	9.986^*
16.23	2.124		

* Not shown on plot

FIG. 165

SPECIFIC HEAT OF MANGANOUS SELENIDE Mn Se

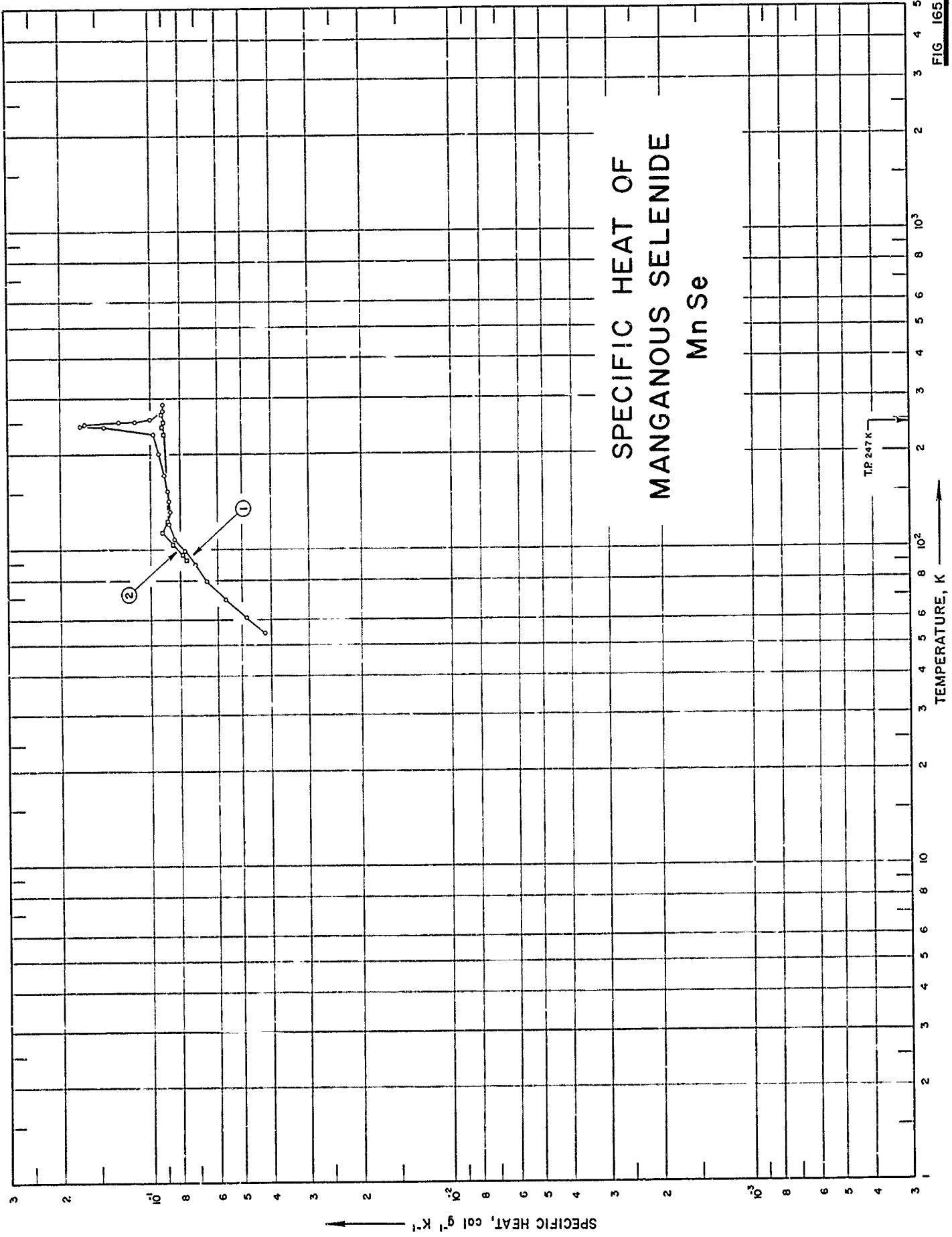

SPECIFICATION TABLE NO. 165 SPECIFIC HEAT OF MANGANOUS SELENIDE MnSe

[For Data Reported in Figure and Table No. 165 J]

Curve No.	Ref. No.	Year	Temp. Range, K	Reported Error, %	Name and Specimen Designation	Composition (weight percent), Specifications and Remarks
1	221	1939	54-287			99.33 MnSe.
2	221	1939	93-266			Same as above.

DATA TABLE NO. 165 SPECIFIC HEAT OF MANGANOUS SELENIDE MnSe
 [Temperature, T, K; Specific Heat, C_p , Cal $g^{-1} K^{-1}$]

T	C_p		T	C_p
	CURVE 1	CURVE 1 (cont.)		
54.3	4.20×10^{-2}		209.3	9.545×10^{-2} *
57.4	4.50*		218.4	9.642*
61.0	4.85		222.3	9.635*
69.6	5.68		231.0	9.829*
79.2	6.54		237.0	1.019×10^{-1} *
81.3	6.59*		239.5	1.096*
82.5	6.67*		242.7	1.432
84.8	6.87*		245.2	1.727
86.3	6.94*		249.3	1.672
89.7	7.16		251.7	1.291
92.1	7.34*		254.4	1.137
93.4	7.37*		257.7	1.003
96.4	7.611*		261.1	9.590×10^{-2} *
99.0	7.789		264.7	9.231*
100.3	7.865*		268.5	9.171*
101.5	7.909*		273.4	9.112
102.1	7.909*		277.1	9.127*
104.3	8.156*		280.4	9.097*
104.4	8.126*		287.0	9.112
107.4	8.290*			
108.5	8.395			
110.3	8.485*			
111.0	3.462*		92.5	7.603×10^{-2}
112.4	8.656*		95.9	7.835
113.1	8.679*		104.8	8.432
114.7	8.813*		113.7	9.119
115.8	8.880*		122.9	8.783
118.1	8.806*		230.3	9.075
118.4	8.828*		233.9	9.067*
120.3	8.737		237.9	9.067*
120.9	8.664*		243.6	9.104
121.8	8.624*		251.4	9.097
123.5	8.641*		259.0	9.157*
123.8	8.612*		266.4	9.209
124.6	8.634*			
127.5	8.612*			
128.8	8.641*			
132.7	8.675			
133.3	8.701*			
142.4	8.753			
153.1	8.865			
162.0	8.985*			
171.1	9.089			
180.7	9.194*			
180.6	9.336*			
200.0	9.426			

* Not shown on plot

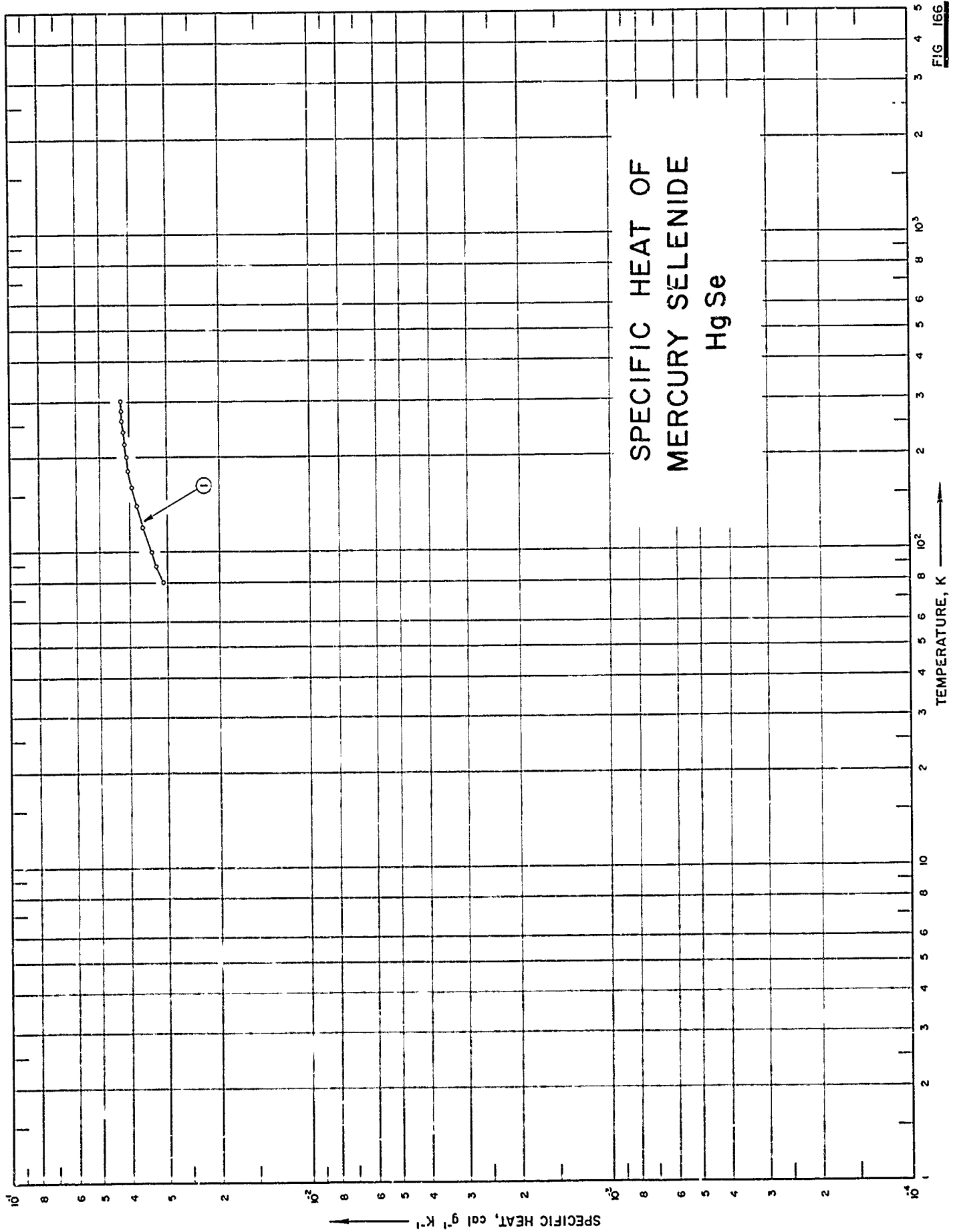

SPECIFICATION TABLE NO. 166 SPECIFIC HEAT OF MERCURY SELENIDE HgSe

[For Data Reported in Figure and Table No. 166]

Curve No.	Ref. No.	Year	Temp. Range, K	Reported Error, %	Name and Specimen Designation	Composition (weight percent), Specifications and Remarks
1	160	1959	80-300	3-7		Polycrystalline.

DATA TABLE NO. 166 SPECIFIC HEAT OF MERCURY SELENIDE HgSe
[Temperature, T, K; Specific Heat, C_p , Cal g⁻¹ K⁻¹]

T	C_p
<u>CURVE 1</u>	
80	3.09 x 10 ⁻²
90	3.25
100	3.39
120	3.61
140	3.77
160	3.91
180	4.01
200	4.08
220	4.14
240	4.18
260	4.22
280	4.25
300	4.26

FIG. 167-1

SPECIFIC HEAT OF NICKEL SELENIDE (Nonstoichiometric) $Ni_x Se$

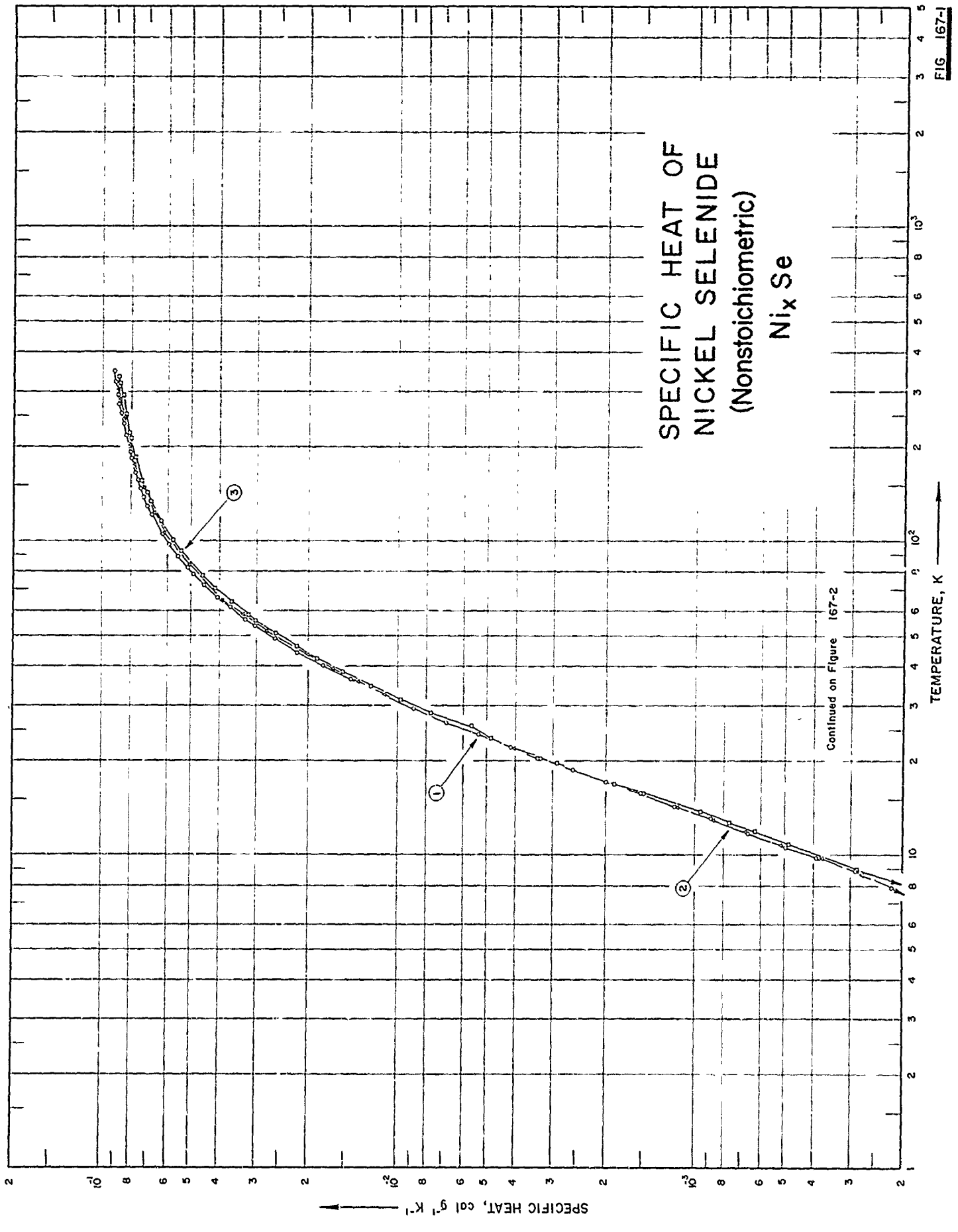

SPECIFIC HEAT, cal g⁻¹ K⁻¹

TEMPERATURE, K

SPECIFIC HEAT OF
NICKEL SELENIDE
(Nonstoichiometric)

Ni_xSe

CONTINUED FROM FIGURE 167-1

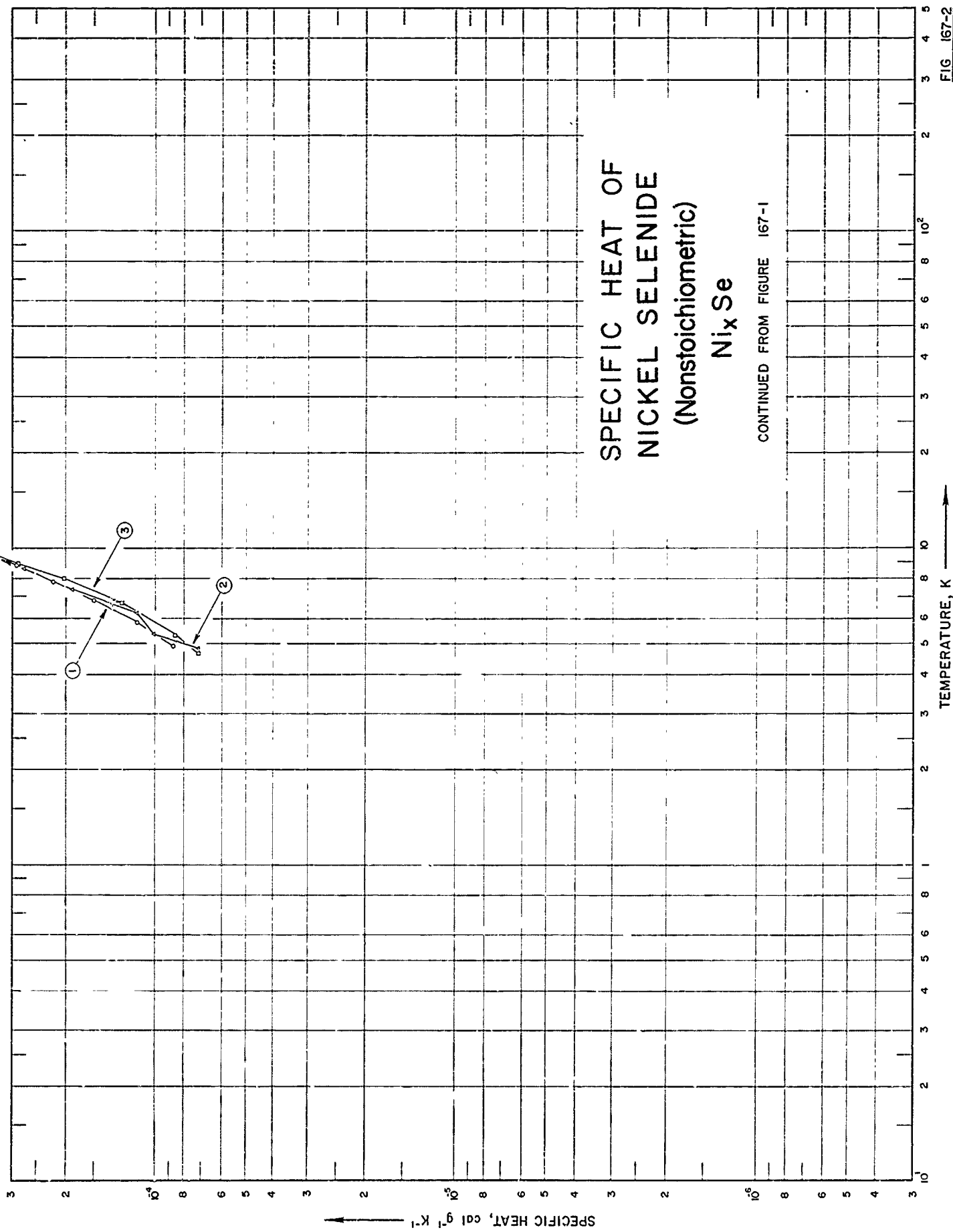
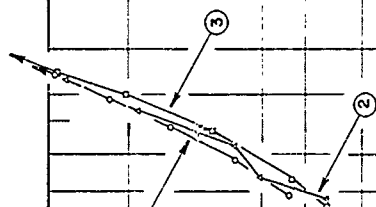

TEMPERATURE, K →

FIG 167-2

SPECIFICATION TABLE NO. 167 SPECIFIC HEAT OF NICKEL SELENIDE (nonstoichiometric) Ni_xSe

[For Data Reported in Figure and Table No. 167]

Curve No.	Ref. No.	Year	Temp. Range, K	Reported Error, %	Name and Specimen Designation	Composition (weight percent), Specifications and Remarks
1	227	1960	5-347	0.1-1.0		$Ni_{0.95}Se$; Ni impurities: 0.01 Al, 0.005 Mg, 0.005 Si, 0.001 each Ca, Co, and Fe, and 0.0001 each Ba, Cu, Cr, and Mn, Se impurities: 0.0002 Cl, 0.00008 Fe, 0.00004 Na and 0.00003 K; prepared by fusion of high purity nickel and selenium; fused for 2 hrs at 1050, 1000, 950 C, respectively, and cooled; fragmented and annealed at 550 C for 7 days and cooled over a period of 2 days; measured in a helium atmosphere.
2	227	1960	5-346	0.1-1.0		$Ni_{0.875}Se$; same as above.
3	227	1960	5-347	0.1-1.0		$Ni_{0.83}Se$; same as above.

DATA TABLE NO. 167 SPECIFIC HEAT OF NICKEL SELENIDE Ni₃Se (nonstoichiometric)[Temperature, T, K; Specific Heat, C_p, Cal g⁻¹ K⁻¹]

CURVE 1		CURVE 1 (cont.)		CURVE 2 (cont.)		CURVE 3		CURVE 3 (cont.)	
T	C _p	T	C _p	T	C _p	T	C _p	T	C _p
Series 1									
56.71	3.286 x 10 ⁻²	156.19	7.576 x 10 ⁻²	32.51	1.103 x 10 ⁻²	156.88	7.361 x 10 ⁻²	25.77	6.164 x 10 ⁻³
61.59	3.692	165.03	7.709	35.80	1.365	165.84	7.504*	28.30	7.784
66.77	4.083	174.05	7.843*	43.27	2.005	174.93	7.632*	31.10	9.763
72.47	4.507	183.04	7.958*	47.41	2.367*	176.40	7.649*	34.58	1.244 x 10 ⁻²
78.89	4.934	182.04	7.948*	51.88	2.758	185.38	7.767	38.33	1.544
Series 2									
4.91	8.684 x 10 ⁻⁵	191.02	8.055	58.25	3.302	194.29	7.872*	42.13	1.861
5.88	1.158 x 10 ⁻⁴	200.06	8.146*	64.59	3.801	203.10	7.960*	46.18	2.187
6.88	1.592	209.17	8.244*	71.20	4.267*	212.01	8.046	50.76	2.590
7.89	2.171	218.35	8.331	77.54	4.683*	221.09	8.130	55.95	3.019
8.84	2.895	227.56	8.399*	84.02	5.086	230.22	8.206*	58.08	3.182
9.76	3.908	237.01	8.489*	90.82	5.448*	239.42	8.278*	64.04	3.649
10.66	4.921	246.47	8.587*	98.27	5.788*	248.79	8.335*	70.82	4.134
11.78	6.658	255.78	8.652	106.39	6.117	254.12	8.369	77.82	4.591
13.03	8.829	264.93	8.703*	114.65	6.412*	263.27	8.432*	84.76	5.017*
14.32	1.171 x 10 ⁻³	274.18	8.770	123.00	6.668	272.43	8.486*	92.43	5.400
15.65	1.520	283.53	8.825*	131.36	6.898*	281.60	8.539*	100.64	5.768
17.08	1.994	292.84	8.886*	139.77	7.098*	290.82	8.591*	108.85	6.091*
18.62	2.558	302.13	8.922*	148.46	7.291	300.14	8.639*	116.87	6.368
20.27	3.280	311.55	8.959*	157.25	7.459*	309.57	8.695*	125.13	6.619*
22.09	4.197	321.06	9.000*	166.19	7.600*	319.10	8.758	134.31	6.865
24.11	5.326	330.48	9.042*	175.18	7.727	328.61	8.818*	142.84	7.061
26.48	6.830	339.86	9.087*	184.20	7.843*	337.72	8.882	151.64	7.241*
29.29	8.822	347.33	9.113	193.28	7.956*	346.76	8.942*		
CURVE 2									
4.82	7.193 x 10 ⁻⁶	202.40	8.054	202.40	8.054	202.40	8.054		
5.39	1.007 x 10 ⁻⁴	211.59	8.141*	211.59	8.141*	211.59	8.141*		
5.28	1.151	220.65	8.223*	220.65	8.223*	220.65	8.223*		
7.42	1.870	229.79	8.297*	229.79	8.297*	229.79	8.297*		
8.60	2.733	239.01	8.363*	239.01	8.363*	239.01	8.363*		
10.76	3.740	248.11	8.435	248.11	8.435	248.11	8.435		
11.84	6.762	257.09	8.492*	257.09	8.492*	257.09	8.492*		
12.98	8.689	265.97	8.558*	265.97	8.558*	265.97	8.558*		
14.27	1.147 x 10 ⁻³	274.98	8.635*	274.98	8.635*	274.98	8.635*		
15.66	1.519*	283.88	8.707*	283.88	8.707*	283.88	8.707*		
17.11	1.984*	292.94	8.773*	292.94	8.773*	292.94	8.773*		
18.57	2.528*	302.05	8.855	302.05	8.855	302.05	8.855		
20.13	3.179*	311.05	8.920*	311.05	8.920*	311.05	8.920*		
21.94	4.057	320.15	8.973*	320.15	8.973*	320.15	8.973*		
24.12	5.242*	329.40	9.023*	329.40	9.023*	329.40	9.023*		
26.66	6.811*	338.66	9.088*	338.66	9.088*	338.66	9.088*		
29.47	8.750*	345.99	9.102*	345.99	9.102*	345.99	9.102*		
Series 3									
82.09	5.125 x 10 ⁻²	4.68	7.147 x 10 ⁻⁵	4.68	7.147 x 10 ⁻⁵	4.68	7.147 x 10 ⁻⁵		
89.30	5.535	5.36	8.576	5.36	8.576	5.36	8.576		
97.37	5.910	5.48	8.576*	5.48	8.576*	5.48	8.576*		
105.89	6.250	6.73	1.286 x 10 ⁻⁴	6.73	1.286 x 10 ⁻⁴	6.73	1.286 x 10 ⁻⁴		
113.91	6.538	8.97	2.001	8.97	2.001	8.97	2.001		
121.59	6.782	9.87	3.716*	9.87	3.716*	9.87	3.716*		
129.88	7.014	10.87	4.860	10.87	4.860	10.87	4.860		
138.58	7.227	11.80	6.275	11.80	6.275	11.80	6.275		
147.33	7.409	12.67	7.690	12.67	7.690	12.67	7.690		
		13.60	9.563	13.60	9.563	13.60	9.563		
		14.38	1.129 x 10 ⁻³ *	14.38	1.129 x 10 ⁻³ *	14.38	1.129 x 10 ⁻³ *		
		15.68	1.489	15.68	1.489	15.68	1.489		
		16.89	1.862	16.89	1.862	16.89	1.862		
		18.15	2.308*	18.15	2.308*	18.15	2.308*		
		19.63	2.902	19.63	2.902	19.63	2.902		
		21.49	3.759	21.49	3.759	21.49	3.759		
		23.56	4.858	23.56	4.858	23.56	4.858		

* Not shown on plot

SPECIFIC HEAT OF NICKEL DISELENIDE NiSe₂

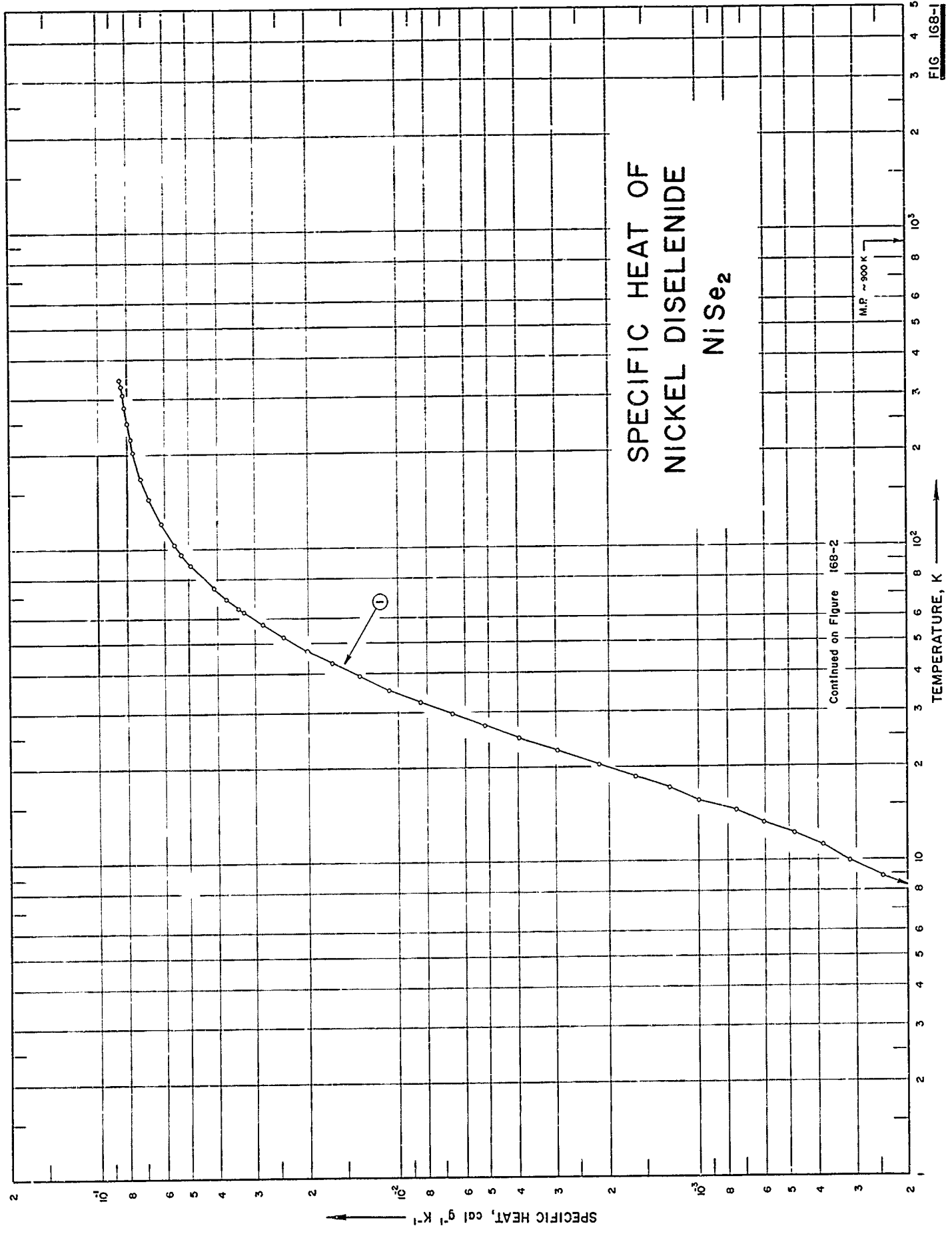

FIG 168-1

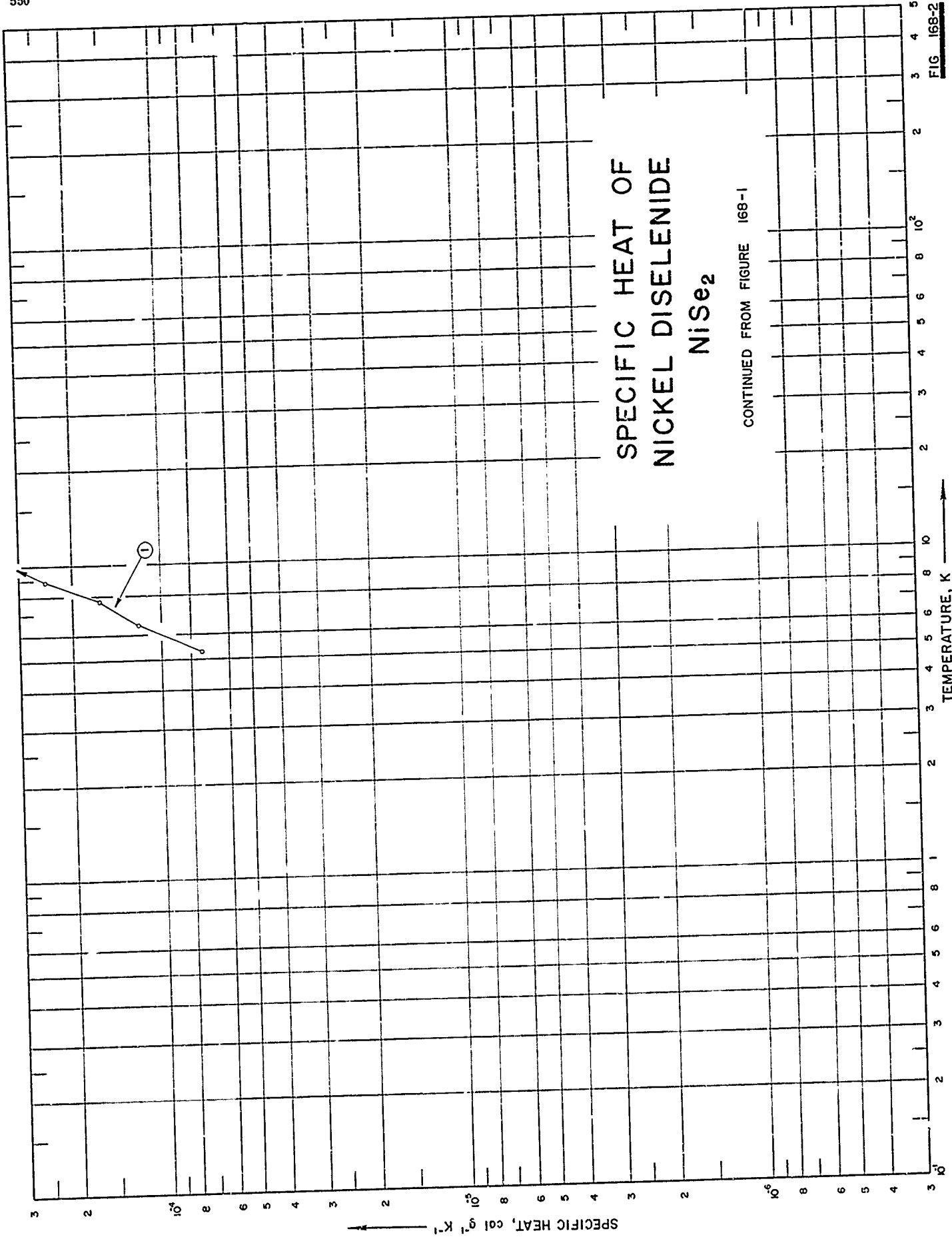

FIG 168-2

SPECIFICATION TABLE NO. 168 SPECIFIC HEAT OF NICKEL DISELENIDE NiSe₂

[For Data Reported in Figure and Table No. 168]

Curve No.	Ref. No.	Year	Temp. Range, K	Reported Error, %	Name and Specimen Designation	Composition (weight percent),	Specifications and Remarks
1	214	1962	5-345	0.1-5		Impurities, 0.01 Al, 0.005 Mg, Si, 0.001 Ca, Co, Fe, 0.0001 Cr, Cu, and Mn; prepared from nickel oxide by reduction with H ₂ at 500 C for 5 hrs; after cooling was fragmented and heated with H ₂ at 1000 C for 4 hrs; mixture of Ni and Se was heated in an evacuated and sealed silica tube at 800 C for 1 day; then temperature lowered to 400 C for 3 days; product crushed and heated at 400 C for 1 wk; heated to 500 C for 1 wk; annealed at 300 C for 1 wk.	

DATA TABLE NO. 168 SPECIFIC HEAT OF NICKEL DISELENIDE NiSe₂[Temperature, T, K; Specific Heat, C_p, Cal g⁻¹K⁻¹]

T	C _p	T	C _p
CURVE 1		CURVE 1 (cont.)	
Series 1			
64.88	3.422 x 10 ⁻²	11.20	3.831 x 10 ⁻⁴
69.16	3.731*	12.27	4.805
76.04	4.122	13.35	6.052
81.54	4.531*	14.54	7.455
88.85	4.940	15.77	9.832
96.10	5.284	17.10	1.251 x 10 ⁻³
103.76	5.604	18.61	1.621
112.23	5.924*	20.40	2.157
120.73	6.202	22.57	2.965
129.02	6.443*	24.89	3.982
136.89	6.643*	27.20	5.165
144.63	6.800	29.67	6.624
152.32	6.970*	32.48	8.480
151.60	6.952*	35.67	1.076 x 10 ⁻²
159.52	7.090*	39.26	1.354
167.82	7.234	43.29	1.677
176.80	7.363*	47.44	2.023
186.18	7.483*	52.26	2.425
195.62	7.594*	57.17	2.827
204.99	7.691	62.87	3.277
214.17	7.778*	69.18	3.733
223.30	7.852		
232.28	7.926*		
241.27	8.000*		
250.48	8.060		
262.05	8.124*		
271.20	8.184*		
280.33	8.231		
289.44	8.286*		
298.50	8.328*		
307.57	8.364		
316.73	8.406*		
325.99	8.448		
335.39	8.485*		
344.95	8.526		
Series 2			
5.27	7.385 x 10 ⁻⁵		
6.43	1.200 x 10 ⁻⁴		
7.69	1.616		
8.92	2.447		
10.06	3.139		

* Not shown on plot

FIG. 169

SPECIFIC HEAT OF DISILVER SELENIDE Ag₂Se

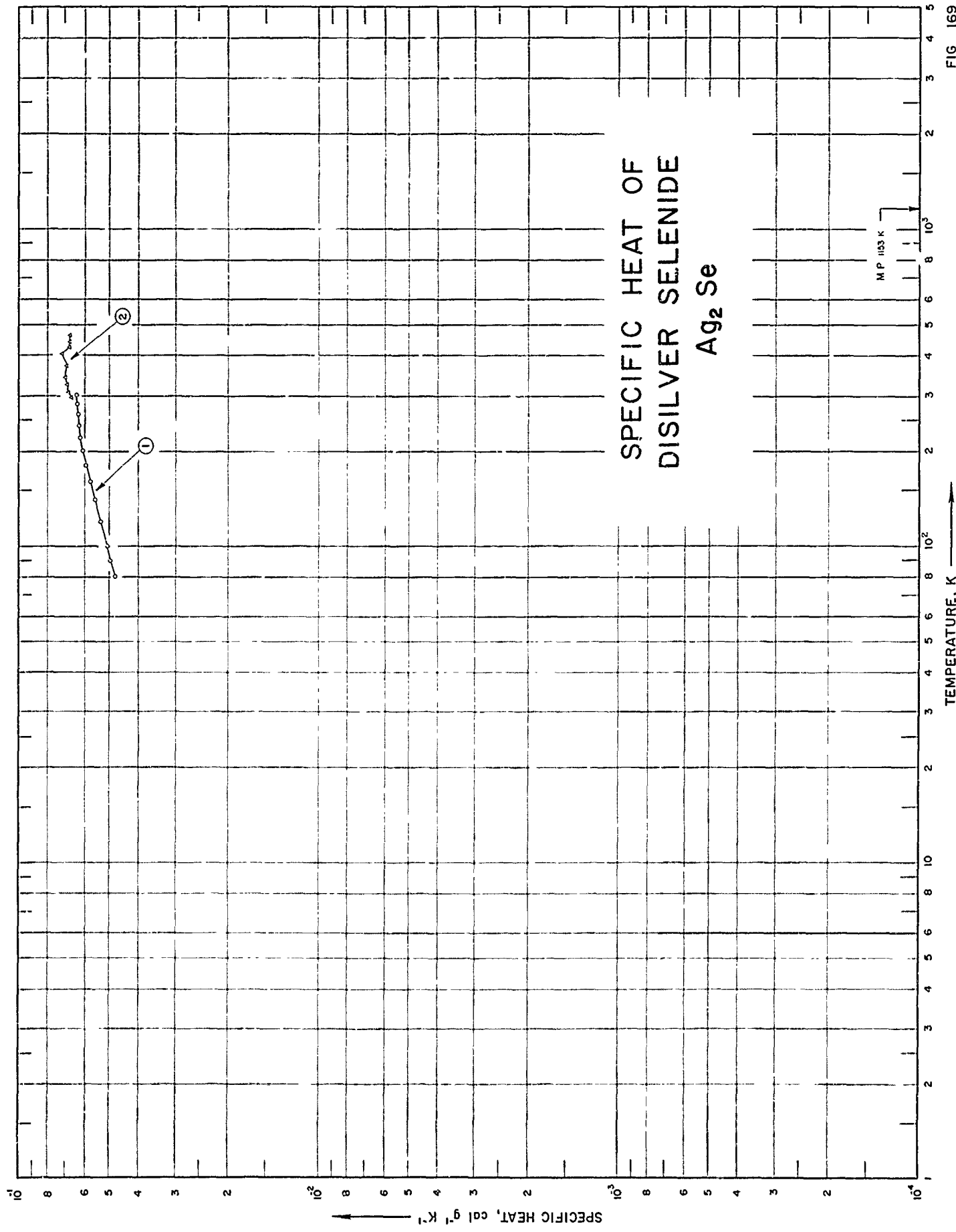

SPECIFICATION TABLE NO. 169 SPECIFIC HEAT OF DISILVER SELENIDE Ag_2Se

[For Data Reported in Figure and Table No. 169]

Curve No.	Ref. No.	Year	Temp. Range, K	Reported Error, %	Name and Specimen Designation	Composition (weight percent), Specifications and Remarks
1	160	1959	80-300	3-7		Polycrystalline
2	228	1962	308-444	5.0		Spectroscopically pure; single crystal; zone melted under controlled vapor pressure; cooled to 150 C at 5-10 C per hr; annealed for several hrs below transition.

DATA TABLE NO. 169 SPECIFIC HEAT OF DISILVER SELENIDE Ag_2Se
 [Temperature, T, K; Specific Heat, C_p , Cal g $^{-1}$ K $^{-1}$]

T	C_p	T	C_p
<u>CURVE 1</u>		<u>CURVE 2 (cont.)</u>	
80	4.77×10^{-2}	Series 2 (cont.)	
90	4.95	379.2	6.880×10^{-2} *
100	5.1	388.4	7.000*
120	5.36	398.2	7.050*
140	5.6	414.2	6.900*
160	5.8	420.2	6.700*
180	5.99	436.3	6.930*
200	6.14	442.9	6.750*
220	6.24	452.5	6.790*
240	6.31	465.3	6.740
260	6.36		
280	6.4		
300	6.42		
<u>CURVE 2</u>			
Series 1			
308.0	6.880×10^{-2}		
318.4	6.940*		
333.4	6.970*		
341.4	7.070		
350.2	7.090*		
358.2	7.220*		
367.4	6.860*		
374.4	6.920		
392.4	7.080*		
399.2	7.190*		
405.4	7.270		
410.7	6.780*		
419.2	6.830*		
430.0	6.850		
436.9	6.800*		
443.9	6.800		
Series 2			
295.3	6.710×10^{-2}		
303.4	6.805*		
314.4	6.940*		
326.0	6.960		
333.6	7.050*		
342.4	7.080*		
350.0	7.110*		
363.5	7.150*		
366.2	7.000*		
372.4	6.850*		

* Not shown on plot

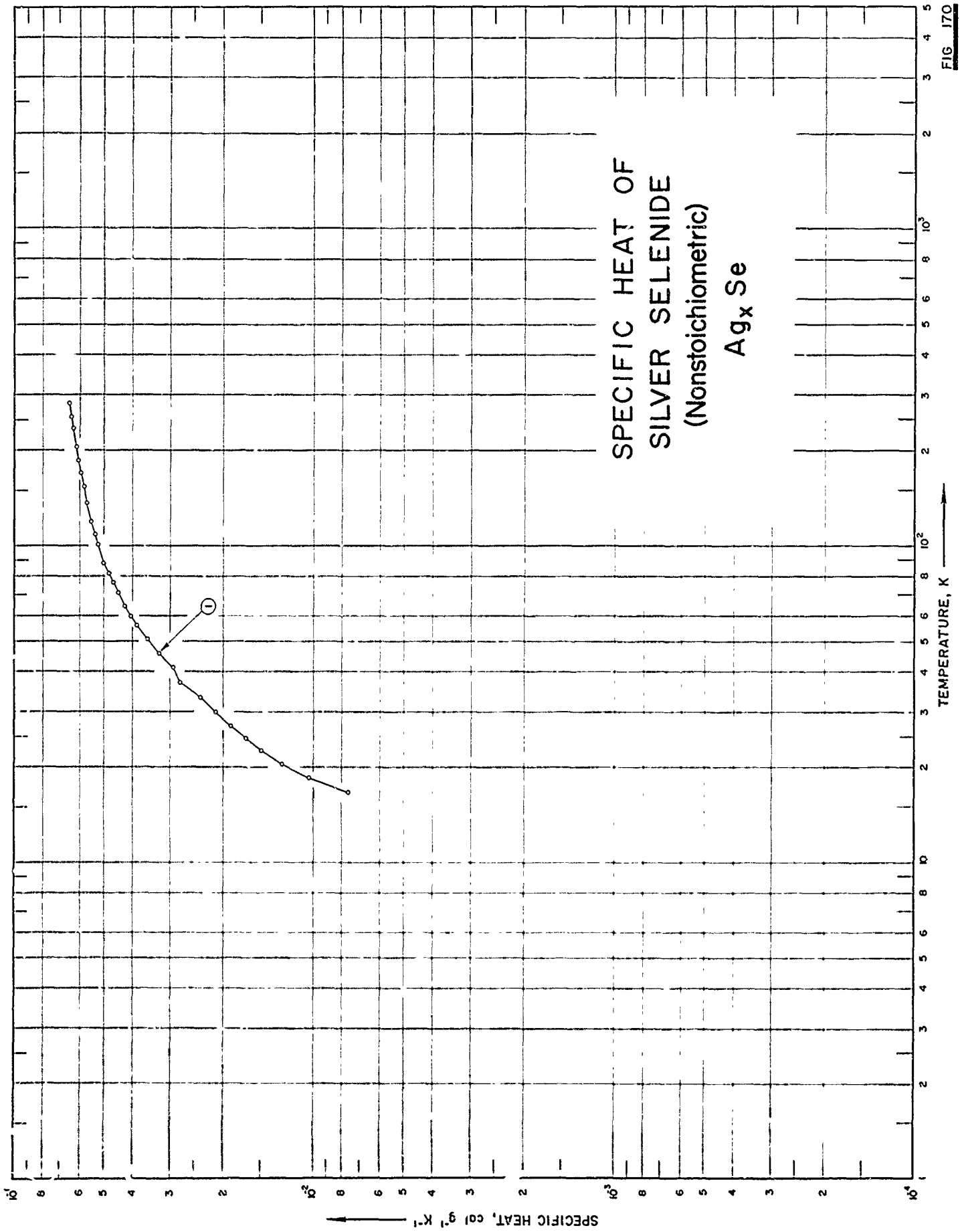

FIG 170

SPECIFICATION TABLE NO. 170 SPECIFIC HEAT OF SILVER SELENIDE (nonstoichiometric) Ag_xSe

[For Data Reported in Figure and Table No. 170]

Curve No.	Ref. No.	Year	Temp. Range, K	Reported Error, %	Name and Specimen Designation	Composition (weight percent), Specifications and Remarks
1	225	1962	17-283		$\text{Ag}_{1.99}\text{Se}$	99.99 $\text{Ag}_{1.99}\text{Se}$; crushed under argon atmosphere.

DATA TABLE NO. 170 SPECIFIC HEAT OF SILVER SELENIDE Ag_2Se (nonstoichiometric)
 [Temperature, T, K; Specific Heat, C_p , Cal $\text{g}^{-1} \text{K}^{-1}$]

T	C_p
CURVE 1	
16.66	7.696×10^{-3}
18.53	1.039×10^{-2}
20.57	1.277
22.63	1.492
24.74	1.686
27.00	1.887
29.87	2.111
33.20	2.364
37.00	2.789
41.33	2.336
45.93	3.286
50.73	3.572
56.03	3.872
60.06	4.032
64.82	4.274
71.24	4.495
77.13	4.672
82.85	4.829
88.23	5.016
91.96	5.040*
101.25	5.234
109.88	5.371
120.90	5.534
129.13	5.629*
137.34	5.708
145.99	5.789*
155.32	5.888
159.87	5.926*
170.60	5.987
178.89	6.062*
187.75	6.127
197.36	6.174*
207.49	6.236
207.83	6.225
216.34	6.270*
217.27	6.283*
235.28	6.331
240.89	6.365*
246.28	6.396*
258.04	6.460
264.47	6.511*
271.07	6.545*
277.34	6.552*
283.48	6.583

* Not shown on plot

FIG. 171

SPECIFIC HEAT OF TRICHRONIUM SILICIDE Cr_3Si

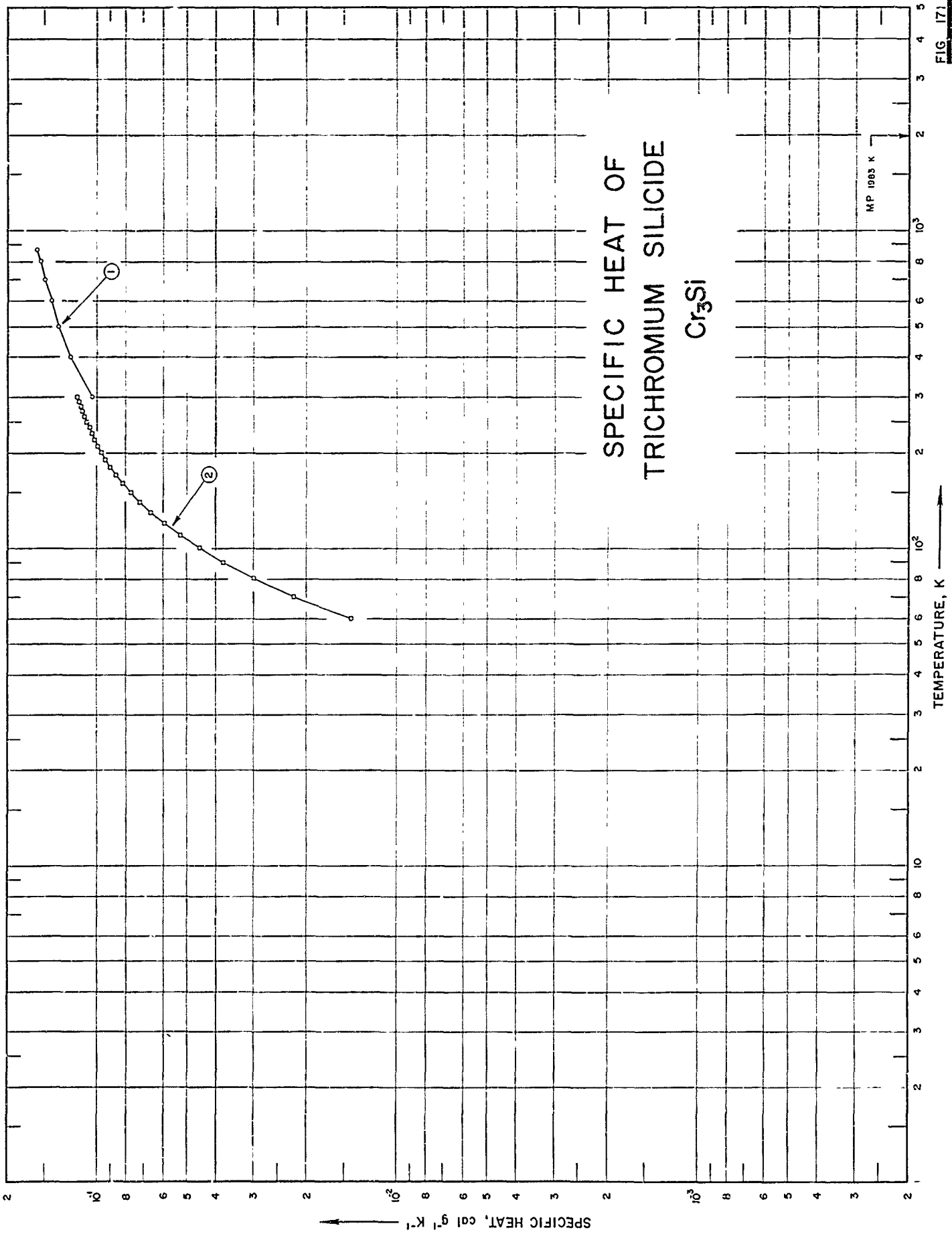

SPECIFICATION TABLE NO. 171 SPECIFIC HEAT OF TRICHRONIUM SILICIDE Cr_3Si

[For Data Reported in Figure and Table No. 171]

Curve No.	Ref. No.	Year	Temp. Range, K	Reported Error, %	Name and Specimen Designation	Composition (weight percent), Specifications and Remarks
1	229	1961	298-873	±2.0	Stoichiometric Cr_3Si ; measured in an argon atmosphere.	
2	418	1965	60-300		Prepared from single crystal silicon (>99.999 Si), and electrolytic chromium (99.98 Cr).	

DATA TABLE NO. 171 SPECIFIC HEAT OF TRICHRONIUM SILICIDE Cr_3Si [Temperature, T, K; Specific Heat, C_p , Cal $\text{g}^{-1} \text{K}^{-1}$]

T	C_p
<u>CURVE 1</u>	
298	1.046×10^{-4} *
300	1.051
400	1.240
500	1.352
600	1.436
700	1.505
800	1.566
873	1.603
<u>CURVE 2</u>	
60	1.4387×10^{-2}
70	2.2198
80	3.0071
90	3.7914
100	4.5549
110	5.2976
120	5.9727
130	6.6479
140	7.2192
150	7.7386
160	8.2060
170	8.6475
180	9.0370
190	9.4006
200	9.6603
210	9.9719
220	1.0232×10^{-1}
230	1.0491
240	1.0699
250	1.0907
260	1.1089
270	1.1270
273.15	1.1322*
280	1.1426
290	1.1581
298.15	1.1738*
300	1.1738

* Not shown on plot

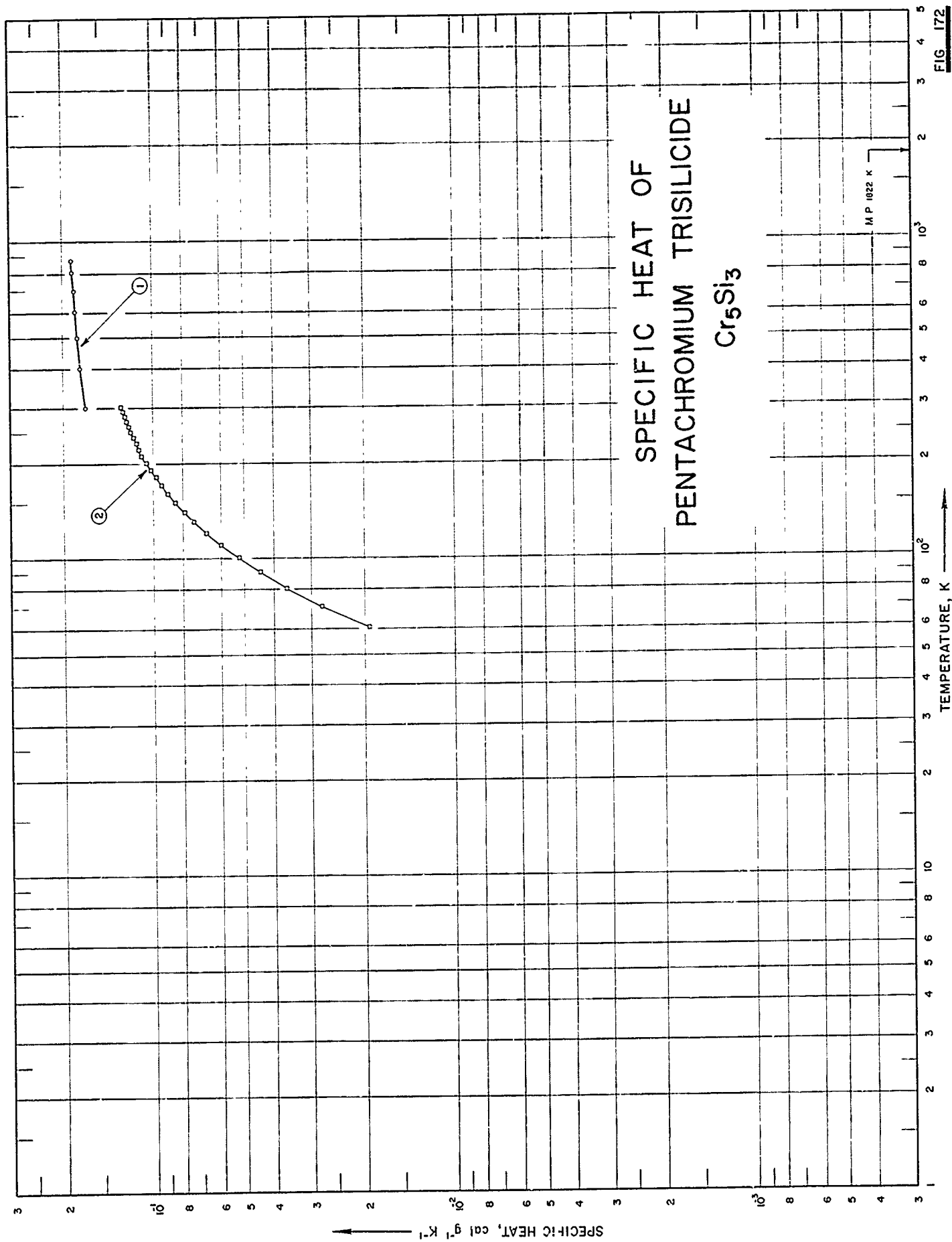

FIG. 172

SPECIFICATION TABLE NO. 172 SPECIFIC HEAT OF PENTACHROMIUM TRISILICIDE Cr_5Si_3

[For Data Reported in Figure and Table No. 172.]

Curve No.	Ref. No.	Year	Temp. Range, K	Reported Error, %	Name and Specimen Designation	Composition (weight percent), Specifications and Remarks
1	229	1961	298-873	±2.0		Stoichiometric Cr_5Si_3 ; measured in an argon atmosphere.
2	418	1965	60-300			Prepared from single crystal silicon (>99.999 Si) and electrolytic chromium (99.98 Cr).

DATA TABLE NO. 172 SPECIFIC HEAT OF PENTACHROMIUM TRISILICIDE Cr_5Si_3 [Temperature, T, K; Specific Heat, C_p , Cal $\text{g}^{-1} \text{K}^{-1}$]

T	C_p
<u>CURVE 1</u>	
298	1.6976×10^{-1} *
300	1.6990
400	1.7505
500	1.7843
600	1.8112
700	1.8349
800	1.8568
873	1.8721
<u>CURVE 2</u>	
60	1.9329×10^{-2}
70	2.7772
80	3.6271
90	4.4547
100	5.2489
110	5.9988
120	6.7209
130	7.3874
140	7.9429
150	8.4983
160	8.9982
170	9.4425
180	9.8314
190	1.0220×10^{-1}
200	1.0553
210	1.1081
220	1.1164
230	1.1442
240	1.1692
250	1.1942
260	1.2136
270	1.2331
273.15	1.2386*
280	1.2497
290	1.2664
298.15	1.2802*
300	1.2830

* Not shown on plot

SPECIFIC HEAT OF CHROMIUM SILICIDE CrSi

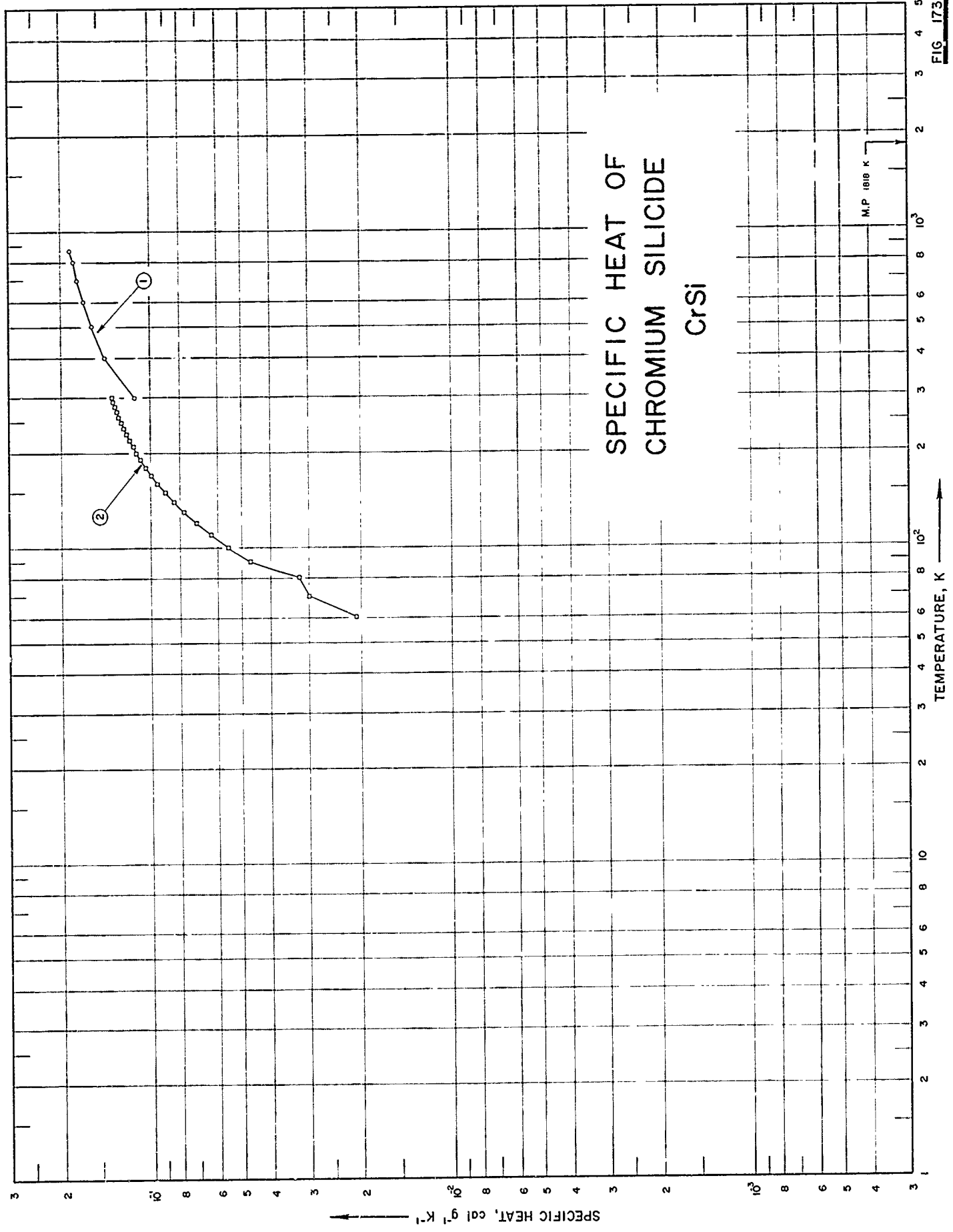

TEMPERATURE, K

SPECIFIC HEAT, cal g⁻¹ K⁻¹

SPECIFICATION TABLE NO. 173 SPECIFIC HEAT OF CHROMIUM SILICIDE CrSi

[For Data Reported in Figure and Table No. 173]

Curve No.	Ref. No.	Year	Temp. Range, K	Reported Error, %	Name and Specimen Designation	Composition (weight percent), Specifications and Remarks
1	229	1961	298-873	±2.0		Stoichiometric CrSi; measured in an argon atmosphere.
2	418	1965	60-300			Prepared from single crystal silicon (>99.999 Si) and electrolytic chromium (99.98 Cr).

DATA TABLE NO. 173 SPECIFIC HEAT OF CHROMIUM SILICIDE CrSi

[Temperature, T, K; Specific Heat, C_p , Cal $g^{-1} K^{-1}$]

T	C_p
<u>CURVE 1</u>	
298	1.1485 x 10 ⁻¹
300	1.1566*
400	1.4328
500	1.5835
600	1.6850
700	1.7631
800	1.8287
873	1.8719
<u>CURVE 2</u>	
60	2.0772 x 10 ⁻²
70	2.9845
80	3.2293
90	4.6678
100	5.5034
110	6.2973
120	7.0435
130	7.7597
140	8.3865
150	8.9535
160	9.4908
170	9.9683
180	1.0386 x 10 ⁻¹
190	1.0774
200	1.1132
210	1.1461
220	1.1759
230	1.2057
240	1.2296
250	1.2535
260	1.2744
270	1.2953
273.15	1.3012*
280	1.3132
290	1.3340
298.15	1.3460*
300	1.3490

* Not shown on plot

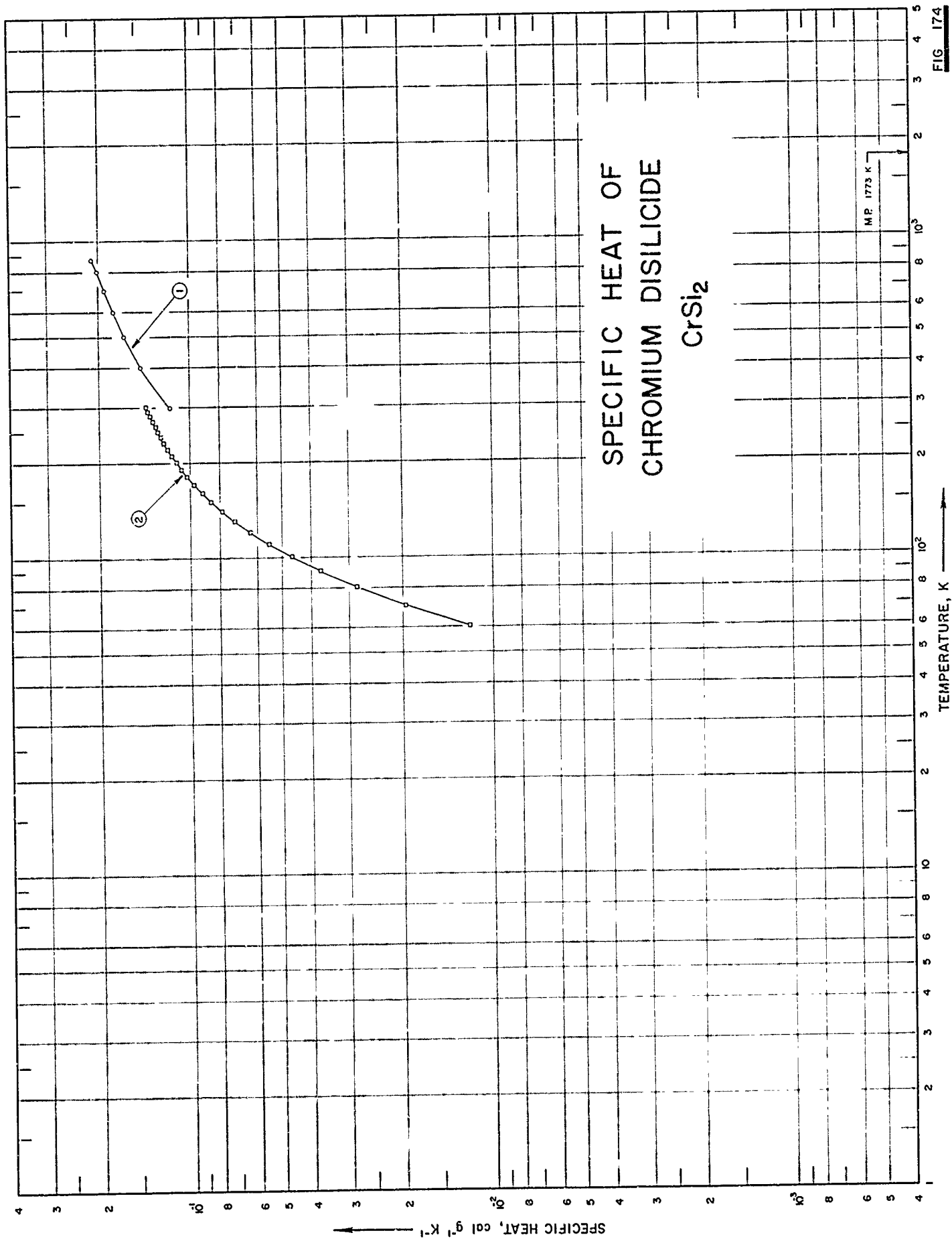

FIG. 174

SPECIFICATION TABLE NO. 174 SPECIFIC HEAT OF CHROMIUM DISILICIDE CrSi_2

[For Data Reported in Figure and Table No. 174]

Curve No.	Ref. No.	Year	Temp. Range, K	Reported Error, %	Name and Specimen Designation	Composition (weight percent), Specifications and Remarks
1	229	1961	298-873	± 2.0		Stoichiometric CrSi_2 ; measured in an argon atmosphere.
2	418	1965	60-300			Prepared from single crystal silicon (>99.999 Si) and electrolytic chromium (99.98 Cr).

DATA TABLE NO. 174 SPECIFIC HEAT OF CHROMIUM DISILICIDE CrSi_2 [Temperature, T, K; Specific Heat, C_p , Cal $\text{g}^{-1} \text{K}^{-1}$]

T	C_p
<u>CURVE 1</u>	
298	1.1772×10^{-1}
300	1.1849*
400	1.4699
500	1.6341
600	1.7987
700	1.9245
800	2.0403
873	2.1210
<u>CURVE 2</u>	
60	1.1998×10^{-2}
76	1.9555
80	2.8106
90	3.7254
100	4.6401
110	5.5151
120	6.3503
130	7.1590
140	7.8882
150	8.5511
160	9.1477
170	9.7442
180	1.0241×10^{-1}
190	1.0739
200	1.1169
210	1.1600
220	1.1965
230	1.2296
240	1.2595
250	1.2893
260	1.3125
270	1.3390
273.15	1.3456*
280	1.3655
290	1.3854
298.15	1.4053*
300	1.4086

* Not shown on plot

FIG 175

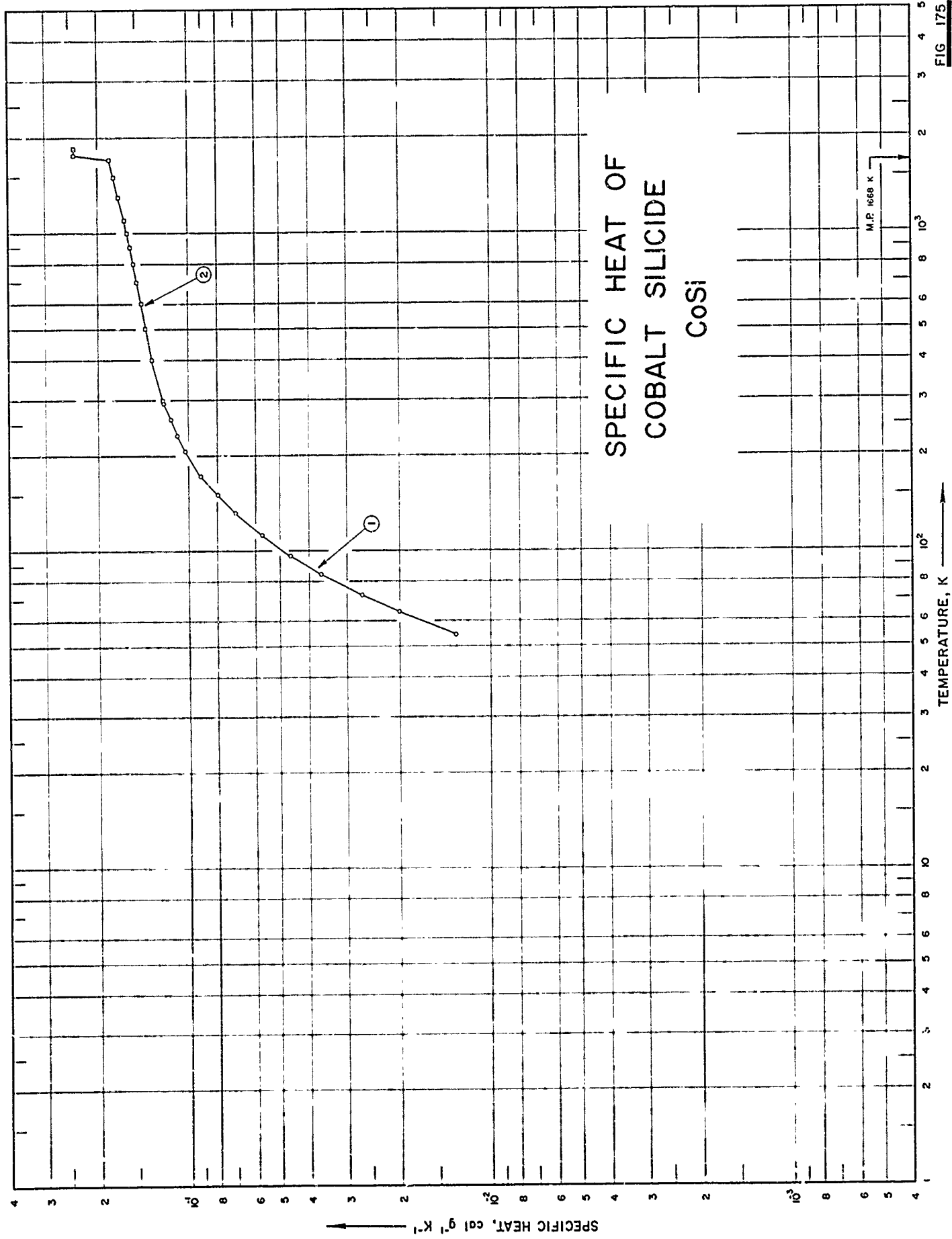

SPECIFICATION TABLE NO. 175 SPECIFIC HEAT OF COBALT SILICIDE CoSi

[For Data Reported in Figure and Table No. 175]

Curve No.	Ref. No.	Year	Temp. Range, K	Reported Error, %	Name and Specimen Designation	Composition (weight percent), Specifications and Remarks
1	230	1964	54-294			Stoichiometric CoSi; (99.98 Co) and (>99.997 Si) melted together in purified argon.
2	230	1964	298-1850			Same as above.

DATA TABLE NO. 175 SPECIFIC HEAT OF COBALT SILICIDE CoSi
 [Temperature, T, K; Specific Heat, C_p , Cal $g^{-1} K^{-1}$]

CURVE 1		CURVE 2	
T	C_p	T	C_p
54.28	1.305×10^{-2}	298.15	1.218×10^{-1}
56.92	1.514*	300	1.219*
58.93	1.675*	400	1.329
64.13	2.013	500	1.395
65.75	2.103*	600	1.447
70.77	2.532*	700	1.491
72.57	2.679	800	1.533
78.46	3.131*	900	1.571
79.99	3.285*	1000	1.607
84.28	3.650	1100	1.642
85.65	3.856*	1200	1.675*
90.38	4.156*	1300	1.711
91.94	4.254*	1400	1.744*
96.53	4.628	1500	1.777
98.74	4.787*	1600	1.813*
105.98	5.257*	1700	1.846
112.22	5.776	1750	2.401
118.69	6.320	1800	2.401*
124.44	6.647*	1850	2.401
131.95	7.075		
138.58	7.487*		
145.91	7.855*		
151.82	8.056		
155.73	8.336*		
162.82	8.589*		
166.21	8.715*		
173.89	9.174		
181.87	9.424*		
184.06	9.632*		
196.73	9.978*		
207.01	1.028×10^{-1}		
218.29	1.060*		
232.30	1.098		
242.21	1.113*		
253.54	1.133*		
260.77	1.150		
268.67	1.151*		
270.54	1.170*		
284.37	1.180*		
286.05	1.199*		
290.42	1.199*		
292.09	1.209*		
293.86	1.215		

* Not shown on plot

FIGURE SHOWS ONLY 1 OF THE CURVES REPORTED IN TABLE

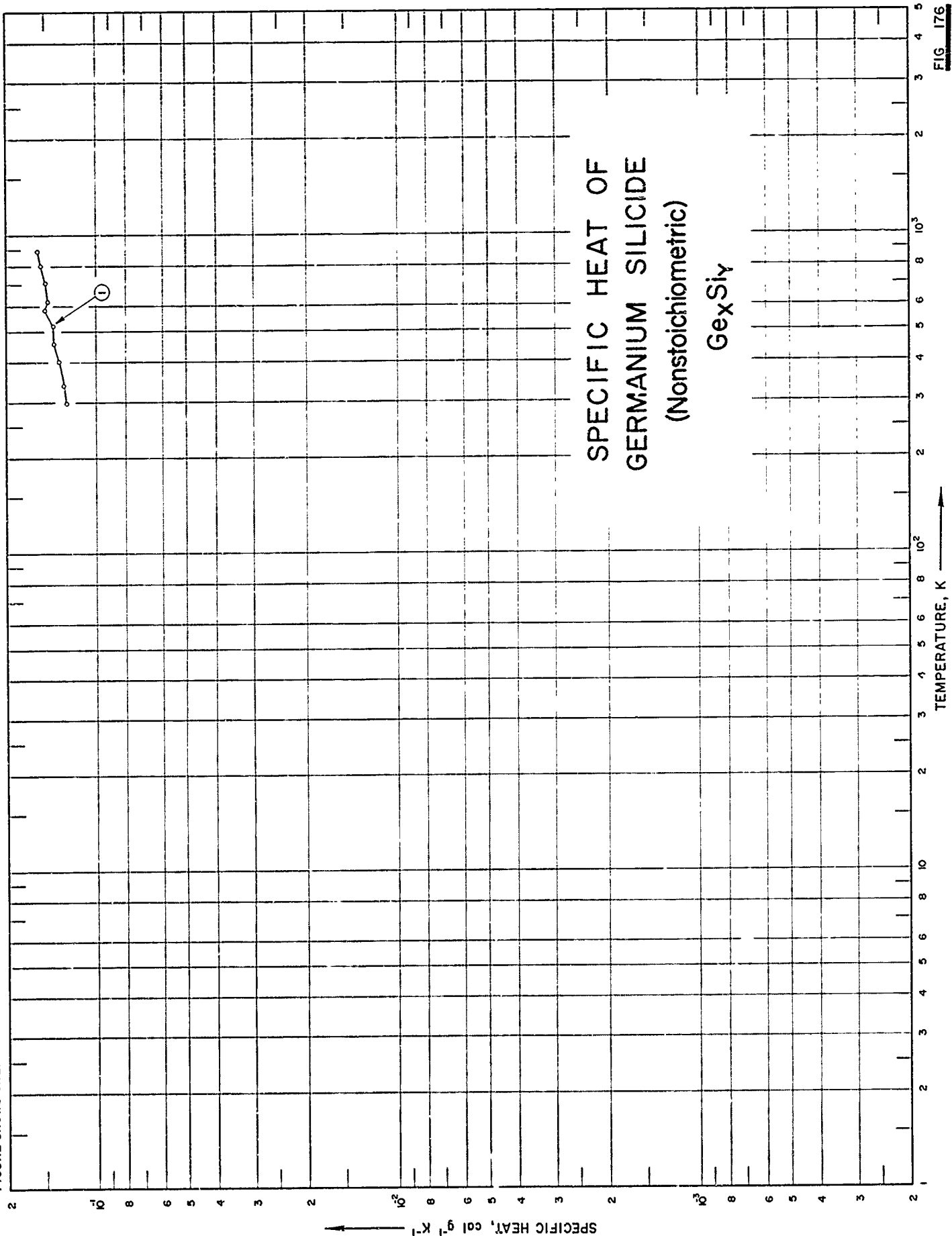

SPECIFICATION TABLE NO. 176 SPECIFIC HEAT OF GERMANIUM SILICIDE Ge_xSi_y (nonstoichiometric)

[For Data Reported in Figure and Table No. 176]

Curve No.	Ref. No.	Year	Temp. Range, K	Reported Error, %	Name and Specimen Designation	Composition (weight percent), Specifications and Remarks
1	231	1964	296-892	2.0-3.0	Si-Ge 46; n-type	52.6 Ge and 47.4 Si; 1.7×10^{-3} ohm cm resistivity.
2	231	1964	295-799	2.0-3.0	Si-Ge 75; p-type	Same as above; 2.0×10^{-3} ohm cm resistivity.

DATA TABLE NO. 176 SPECIFIC HEAT OF GERMANIUM SILICIDE Ge_xSi_y (nonstoichiometric)
 [Temperature, T, K; Specific Heat, C_p , Cal $\text{g}^{-1} \text{K}^{-1}$]

T	C_p
<u>CURVE 1</u>	
296.8	1.257 x 10 ⁻¹
296.0	1.229*
338.0	1.270
401.2	1.326
432.5	1.351*
457.0	1.380
522.0	1.397*
551.0	1.408*
582.7	1.484
587.4	1.408*
620.3	1.459
681.0	1.505*
712.3	1.473
743.2	1.545*
779.2	1.530*
806.4	1.534
846.1	1.534*
869.7	1.502*
891.5	1.564
<u>CURVE 2*</u>	
295.4	1.247 x 10 ⁻¹
356.1	1.305
383.7	1.369
413.6	1.415
451.0	1.411
329.1	1.308
473.7	1.402
509.5	1.412
548.1	1.415
590.8	1.466
623.6	1.428
653.9	1.444
685.8	1.451
735.1	1.480
764.5	1.486
799.3	1.556

* Not shown on plot

FIG 177

SPECIFIC HEAT OF IRON SILICIDE FeSi

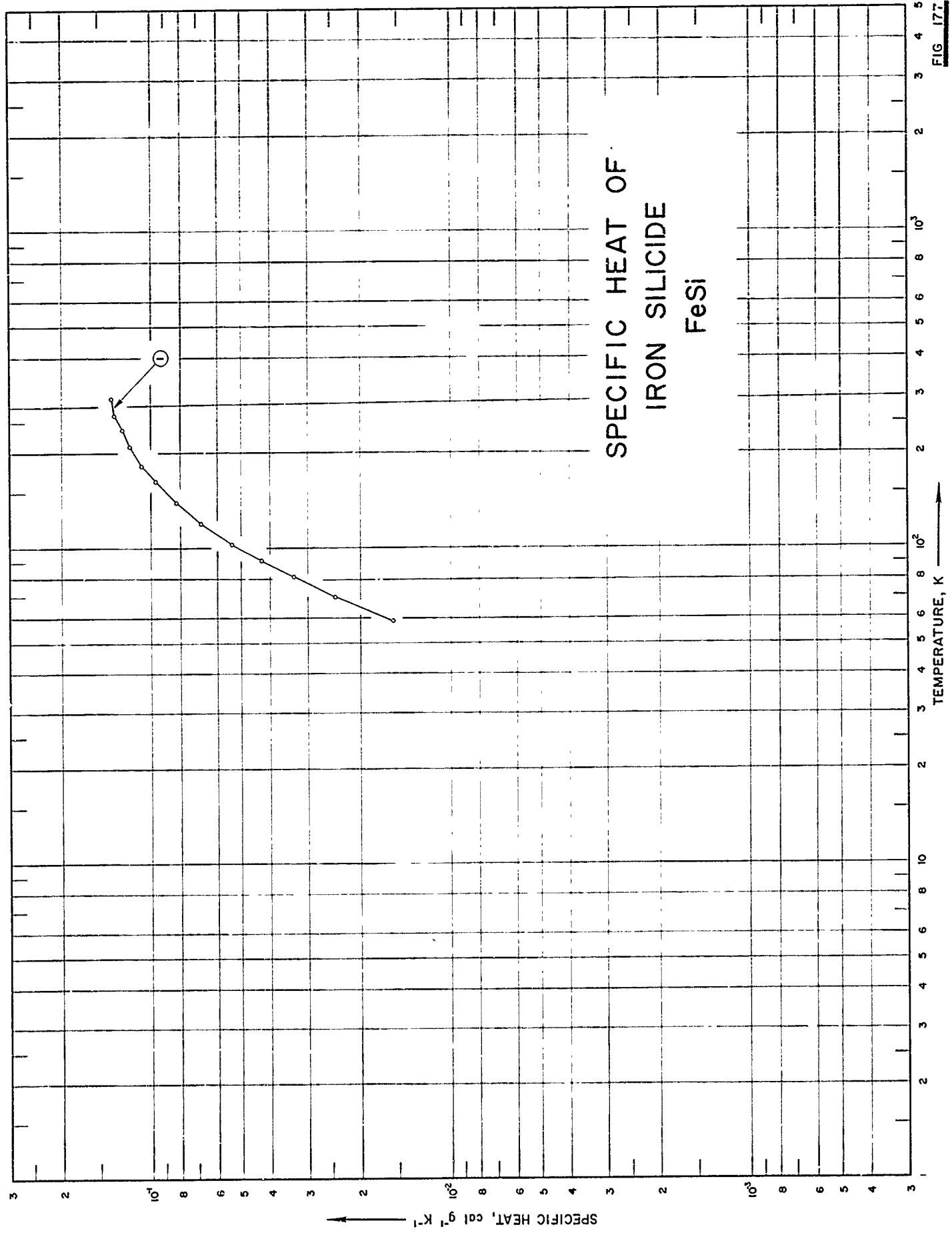

SPECIFICATION TABLE NO. 177 SPECIFIC HEAT OF IRON SILICIDE FeSi

[For Data Reported in Figure and Table No. 177]

Curve No.	Ref. No.	Year	Temp. Range, K	Reported Error, %	Name and Specimen Designation	Composition (weight percent), Specifications and Remarks
1	419	1963	59-298			34.0 Si.

DATA TABLE NO. 177 SPECIFIC HEAT OF IRON SILICIDE FeSi
 [Temperature, T, K; Specific Heat, C_p , Cal g⁻¹ K⁻¹]

T	C_p
<u>CURVE 1</u>	
58.97	1.56×10^{-2}
61.11	1.75*
62.53	1.83*
64.30	1.97*
70.13	2.43
77.07	3.02*
81.23	3.36
84.16	3.66*
85.28	3.74*
91.54	4.29
97.65	4.86*
103.60	5.37
110.30	5.95*
112.68	6.22*
120.70	6.80
125.66	7.19*
128.56	7.52*
133.85	7.86*
140.26	8.26
146.53	8.73*
154.76	9.18*
163.60	9.68
172.54	1.01×10^{-1} *
178.80	1.06*
182.46	1.07
189.41	1.10*
192.34	1.09*
197.91	1.12*
210.29	1.17
217.66	1.20*
226.24	1.22*
237.02	1.25
245.45	1.27*
255.47	1.30*
264.00	1.32
298.16	1.36

* Not shown on plot

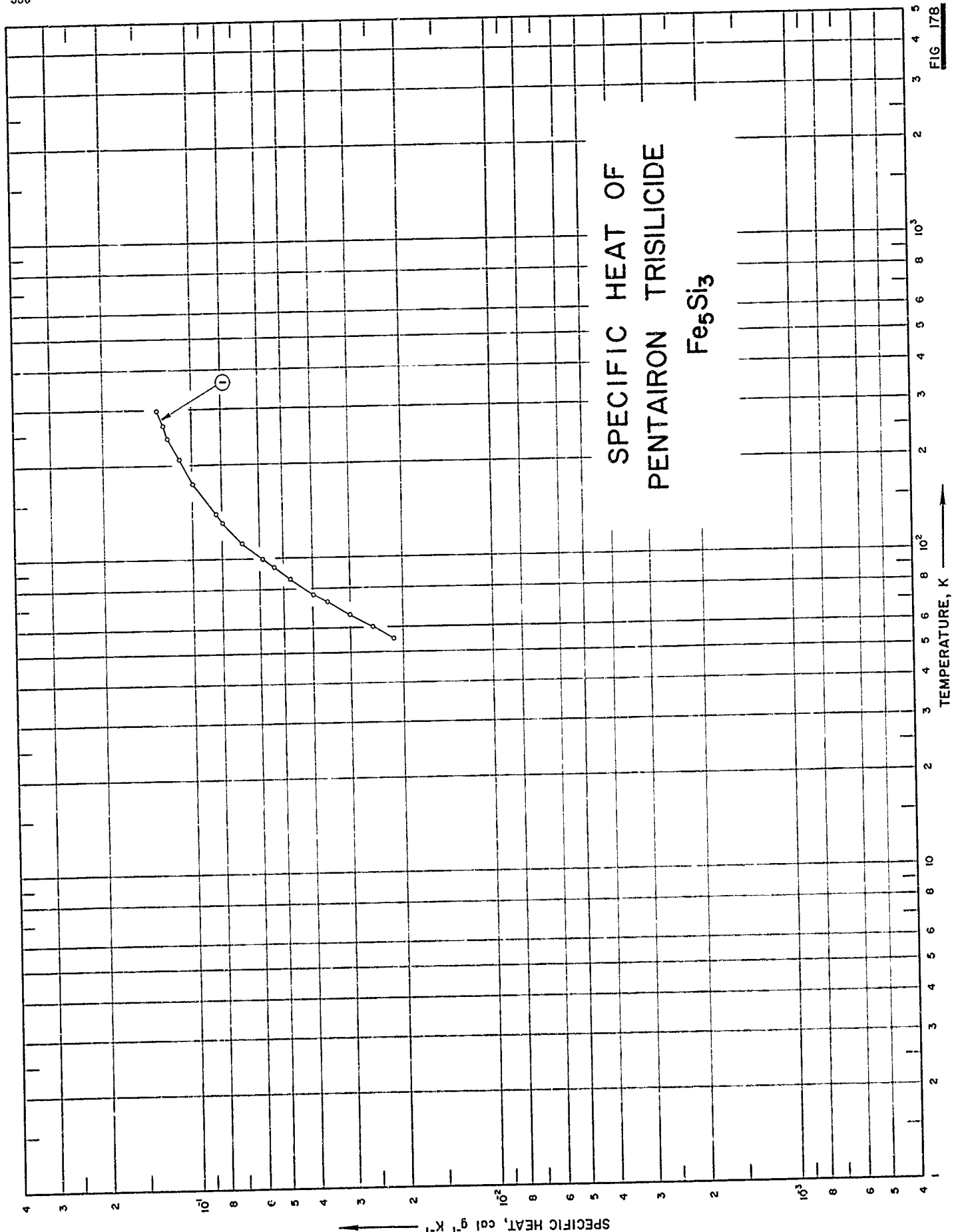

FIG 178

SPECIFICATION TABLE NO. 178 SPECIFIC HEAT OF PENTAIRON TRISILICIDE Fe_3Si_3

[For Data Reported in Figure and Table No. 178]

Curve No.	Ref. No.	Year	Temp. Range, K	Reported Error, %	Name and Specimen Designation	Composition (weight percent)	Specifications and Remarks
1	419	1963	55-298			24.02 Si.	

DATA TABLE NO. 178 SPECIFIC HEAT OF PENTAIRON TRISILICIDE Fe_3Si_3
 [Temperature, T, K; Specific Heat, C_p , Cal $\text{g}^{-1} \text{K}^{-1}$]

T	C_p	T	C_p
55.25	2.16×10^{-2}	1100	1.80×10^{-1}
60.74	2.54	1200	1.86
66.38	3.02	1300	1.92
73.05	3.59		
77.13	3.97		
78.60	4.06*		
86.58	4.78		
94.66	5.38		
100.49	5.87		
113.30	6.85		
122.99	7.51*		
131.14	7.98		
140.33	8.33		
152.35	9.10^*		
164.06	9.55^*		
175.14	1.00×10^{-1}		
185.64	1.04*		
198.66	1.07*		
210.16	1.10		
222.02	1.14*		
231.97	1.18*		
233.45	1.17*		
238.20	1.18*		
244.20	1.21		
246.30	1.21*		
254.02	1.22*		
258.65	1.23*		
260.90	1.23		
266.29	1.26*		
268.88	1.26*		
273.30	1.27*		
277.29	1.27*		
286.34	1.29*		
298.16	1.31		
CURVE 2			
300	1.32×10^{-1}		
400	1.37		
500	1.44		
600	1.50		
700	1.56		
800	1.62		
900	1.68		
1000	1.74		

* Not shown on plot

FIG. 179

SPECIFIC HEAT OF
TRIIRON SILICIDE
 Fe_3Si

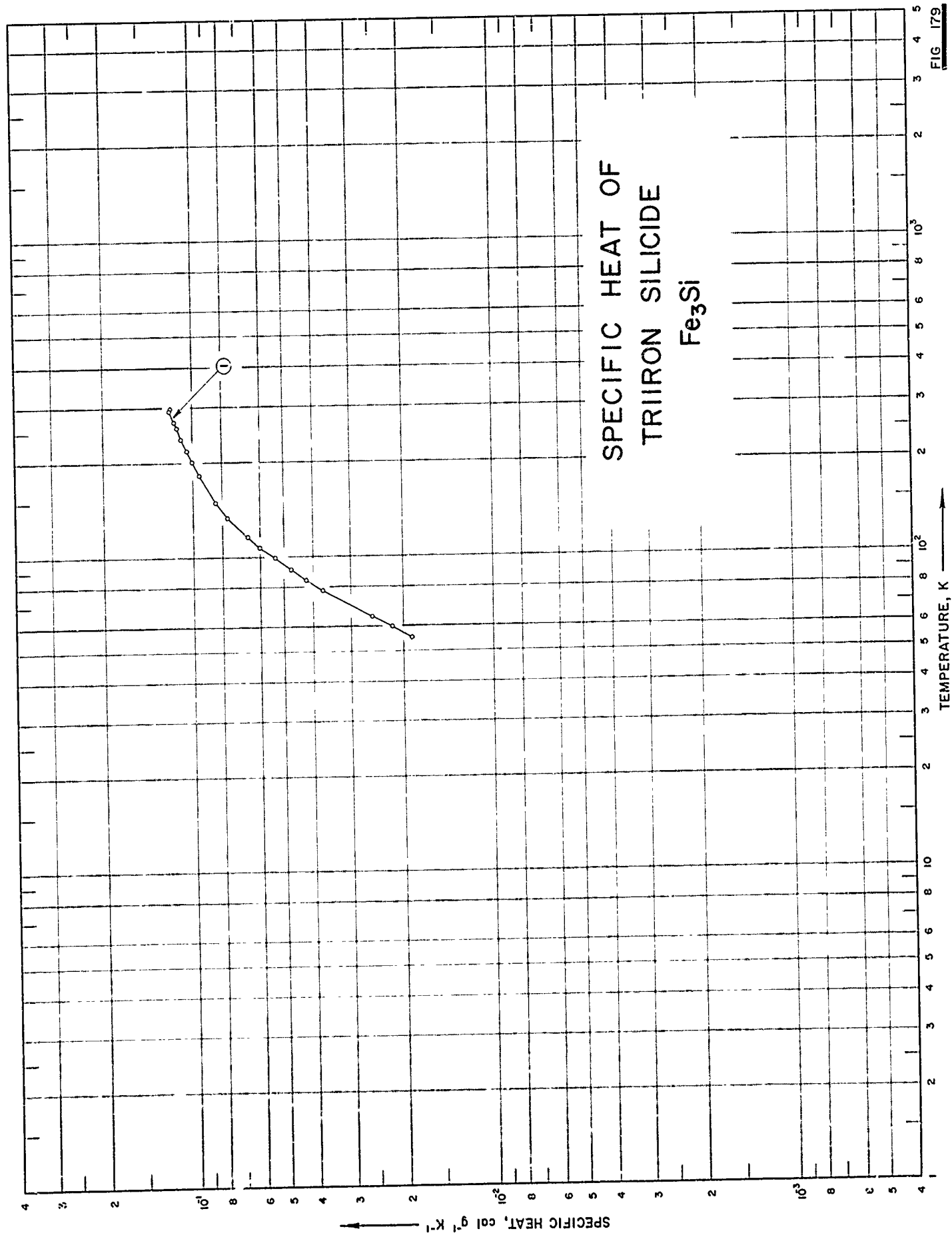

SPECIFICATION TABLE NO. 179 SPECIFIC HEAT OF TRIRON SILICIDE Fe_3Si

[For Data Reported in Figure and Table No. 179]

Curve No.	Ref. No.	Year	Temp. Range, K	Reported Error, %	Name and Specimen Designation	Composition (weight percent), Specifications and Remarks
1	420	1962	55-299	1.0		14.25 Si; stoichiometrically close to Fe_3Si .

DATA TABLE NO. 179 SPECIFIC HEAT OF TRIRON SILICIDE Fe₃Si[Temperature, T, K; Specific Heat, C_p, Cal g⁻¹ K⁻¹]

T	C _p
	<u>CURVE 1</u>
55.25	1.88 x 10 ⁻²
60.44	2.19
64.95	2.55
78.49	3.73
84.80	4.25
91.63	4.76
92.79	4.86*
99.08	5.38
107.90	6.02
116.58	6.61
124.86	7.15*
134.39	7.73
150.12	8.49
157.58	8.73*
166.89	9.16*
184.20	9.59
193.40	9.92*
201.29	1.01 x 10 ⁻¹
210.62	1.03*
219.96	1.05
229.89	1.07*
239.29	1.10
249.27	1.12*
259.35	1.13
259.55	1.13*
270.14	1.16
281.03	1.17*
294.05	1.20
297.83	1.20*
299.45	1.19

* Not shown on plot

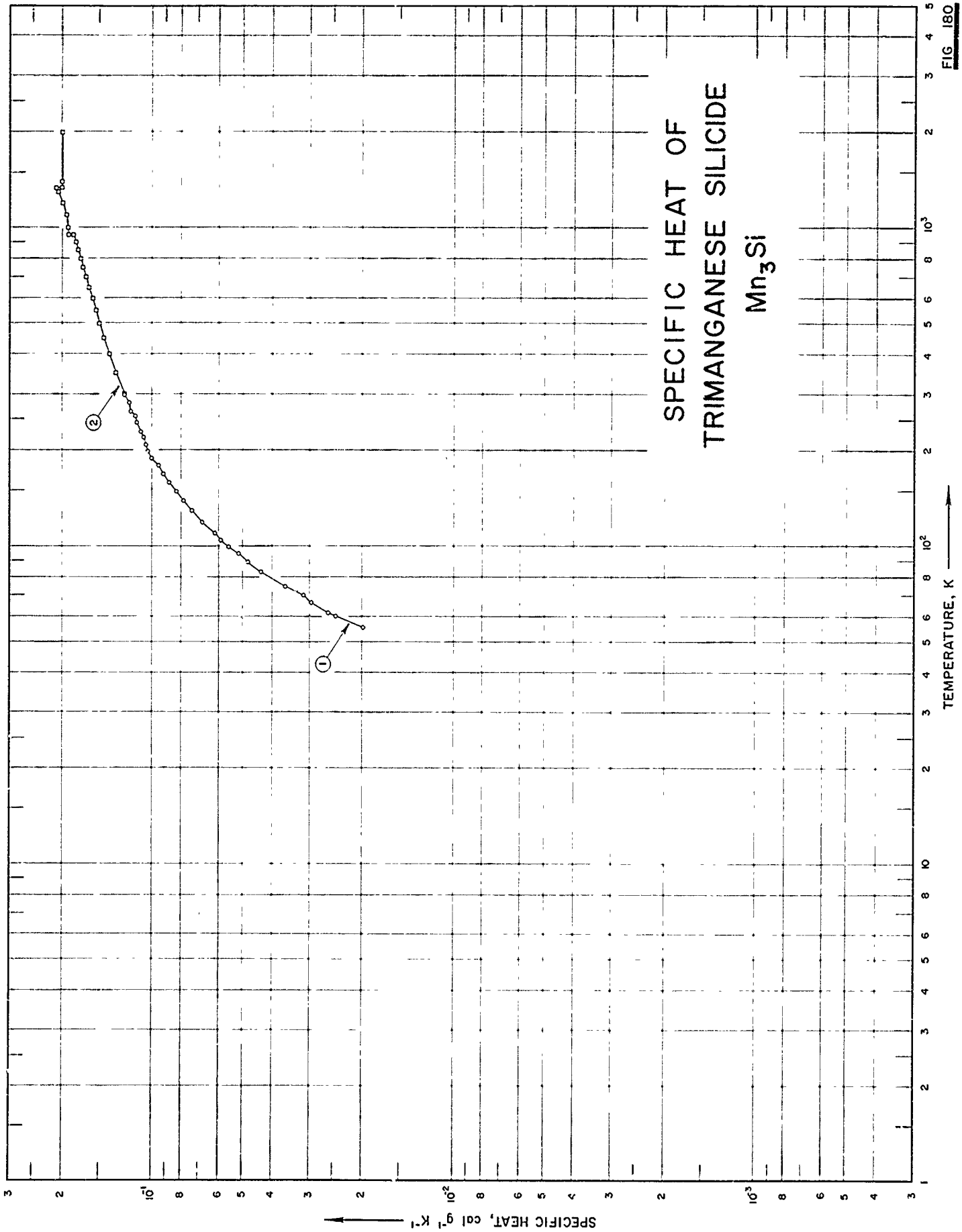

TEMPERATURE, K →

FIG. 180

SPECIFICATION TABLE NO 180 SPECIFIC HEAT OF TRIMANGANESE SILICIDE Mn_3Si

[For Data Reported in Figure and Table No. 180]

Curve No.	Ref. No.	Year	Temp. Range, K	Reported Error, %	Name and Specimen Designation	Composition (weight percent), Specifications and Remarks
1	421	1965	56-300			Prepared from double refined electrolytic manganese (99.98 Mn) and single crystal silicon (99.997 Si, resistivity = 3 c.i.m cm); single phase; vacuum annealed for 24 hrs at 900 C.
2	421	1965	300-2000			Same as above.

DATA TABLE NO. 180 SPECIFIC HEAT OF TRIMANGANESE SILICIDE Mn_3Si [Temperature, T, K; Specific Heat, C_p , Cal $g^{-1} K^{-1}$]

CURVE 1		CURVE 2	
T	C_p 10^{-2}	T	C_p 10^{-1} *
55.53	1.990	300	1.240
60.33	2.467	350	1.323
61.70	2.591	400	1.394
66.67	2.964	450	1.450
70.11	3.130	500	1.500
74.83	3.607	550	1.545
82.89	4.333	600	1.587
89.32	4.809	650	1.627
94.66	5.162	700	1.665
99.32	5.535	750	1.702
104.78	5.908	800	1.738
109.04	6.157	850	1.774
113.55	6.509*	900	1.809
118.00	6.820	950	1.844
122.56	7.048*	950	1.911
129.85	7.380	1000	1.919
138.15	7.857	1100	1.946
142.98	8.064*	1200	1.996
148.64	8.353	1300	2.062
152.23	8.479*	(s) 1343	2.095
158.06	8.790	(c) 1343	2.007
163.13	8.975*	1400	2.007
168.32	9.163	1500	2.007
173.34	9.286*	1600	2.007
179.02	9.535	1700	2.007
183.39	9.866*	1800	2.007
188.01	1.007 $\times 10^{-1}$	1900	2.007
193.26	1.610*	2000	2.007
194.04	1.024*		
198.17	1.032		
203.15	1.045*		
208.14	1.055		
214.92	1.072*		
219.15	1.072		
223.79	1.078*		
230.76	1.094		
239.01	1.111*		
246.59	1.130		
257.15	1.146		
265.61	1.179		
283.61	1.192		
299.53	1.240		

*Not shown on plot

FIG 181

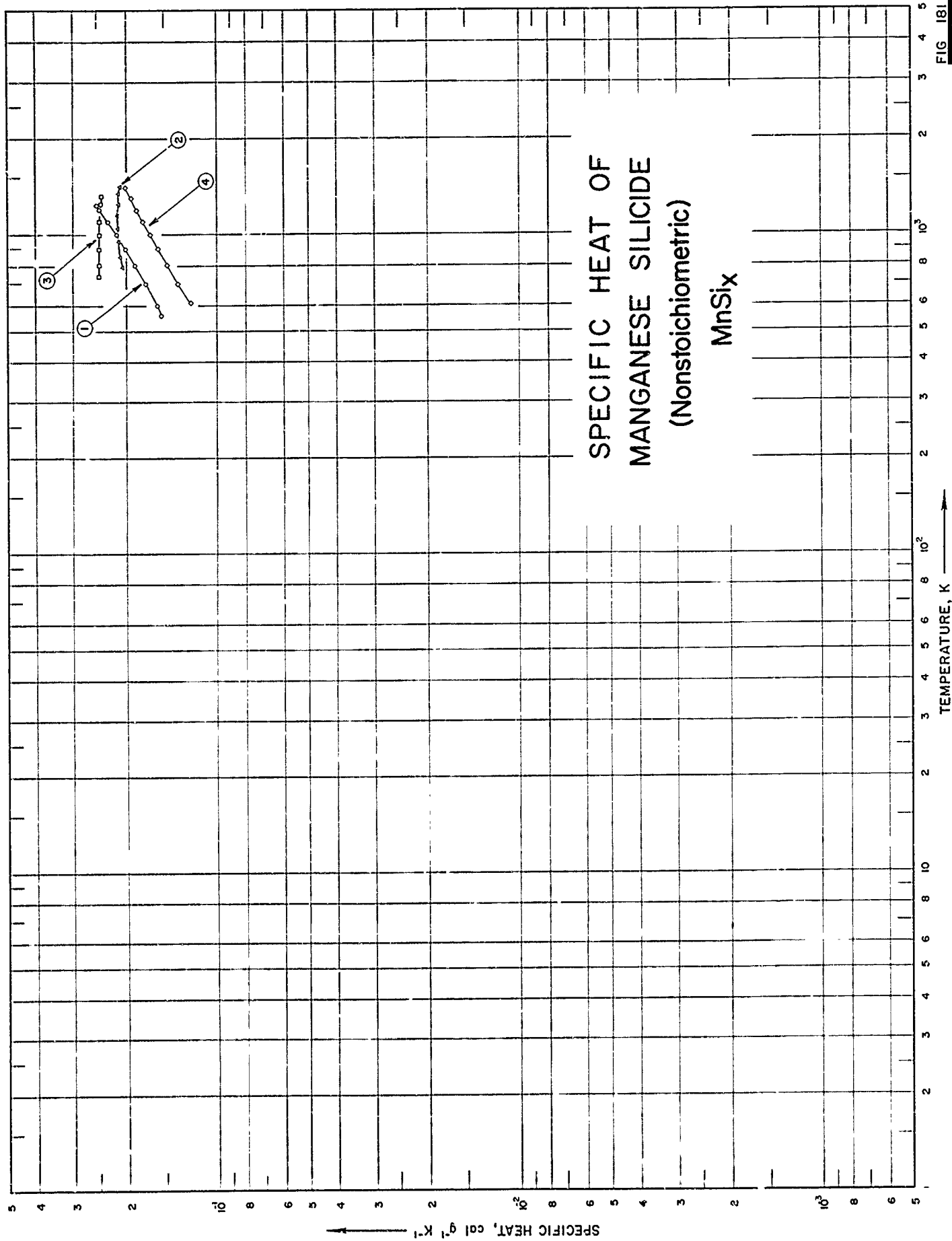

SPECIFICATION TABLE NO. 181 SPECIFIC HEAT OF MANGANESE SILICIDE (nonstoichiometric) $MnSi_x$

[For Data Reported in Figure and Table No. 181]

Curve No.	Ref. No.	Year	Temp. Range, K	Reported Error, %	Name and Specimen Designation	Composition (weight percent), Specifications and Remarks
1	232	1963	558-1241	1.5		$MnSi_{1.0}$, 223*
2	232	1963	732-1418	1.1		$MnSi_{1.0}$
3	232	1963	743-1332	1.6		$MnSi_{1.0}$, 545*
4	232	1963	610-1402	2.8		$MnSi_{2.234}$

DATA TABLE NO. 181 SPECIFIC HEAT OF MANGANESE SILICIDE $MnSi_x$ (nonstoichiometric)
 [Temperature, T, K; Specific Heat, C_p , Cal $g^{-1} K^{-1}$]

T	C_p	T	C_p
<u>CURVE 1</u>			
558	1.535 x 10 ⁻¹	1150	2.150 x 10 ⁻¹
560	1.538*	1200	2.147*
562	1.540*	1250	2.143*
564	1.543*	1300	2.137*
566	1.546*	1350	2.131
568	1.548*	1400	2.123*
570	1.551*	1418	2.119
<u>CURVE 2</u>			
574	1.553*		
576	1.556*		
578	1.559*		
580	1.562*		
582	1.564*		
584	1.567*		
586	1.570*		
588	1.572*		
590	1.575*		
592	1.578*		
594	1.581*		
596	1.584*		
598	1.587*		
600	1.592		
650	1.661*		
700	1.731		
750	1.802*		
800	1.874		
850	1.947*		
900	2.019		
950	2.092*		
1000	2.165		
1050	2.239*		
1100	2.312		
1150	2.385*		
1200	2.459		
1241	2.520		
<u>CURVE 3</u>			
743	2.479 x 10 ⁻¹	743	2.479 x 10 ⁻¹
750	2.479*	750	2.479*
800	2.478*	800	2.478*
850	2.475*	850	2.475*
900	2.472*	900	2.472*
950	2.467*	950	2.467*
1000	2.464	1000	2.464
1050	2.459*	1050	2.459*
1100	2.454	1100	2.454
1150	2.449*	1150	2.449*
1200	2.444*	1200	2.444*
1250	2.440	1250	2.440
1300	2.434*	1300	2.434*
1332	2.431	1332	2.431
<u>CURVE 4</u>			
610	1.228 x 10 ⁻¹	610	1.228 x 10 ⁻¹
700	1.354	700	1.354
800	1.472	800	1.472
900	1.577	900	1.577
1000	1.673	1000	1.673
1100	1.764	1100	1.764
1200	1.852	1200	1.852
1300	1.936	1300	1.936
1402	2.021	1402	2.021
<u>CURVE 2</u>			
792	2.075 x 10 ⁻¹		
800	2.079*		
850	2.103		
900	2.123*		
950	2.135		
1000	2.145*		
1050	2.148		
1100	2.151*		

* Not shown on plot

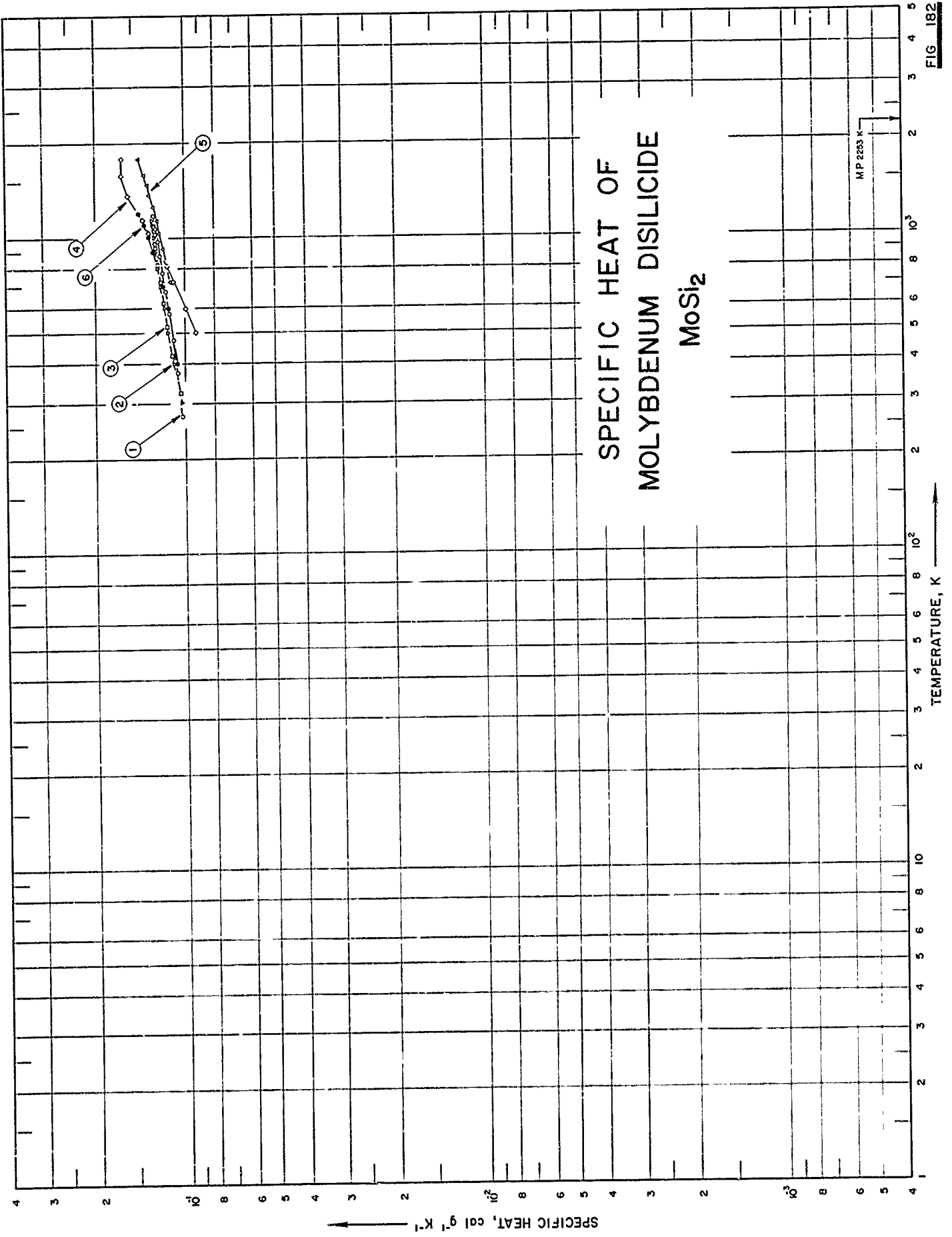

FIG 182

SPECIFICATION TABLE NO. 182 SPECIFIC HEAT OF MOLYBDENUM DISILICIDE MoSi_2

[For Data Reported in Figure and Table No. 182]

Curve No.	Ref. No.	Year	Temp. Range, K	Reported Error, %	Name and Specimen Designation	Composition (weight percent), Specifications and Remarks
1	233	1953	273-1173	3.0		0.8 Fe, 0.50 O_2 , 0.34 N_2 and 0.17 C.
2	234	1954	300-1148			97.8 MoSi_2 , 1.4 Fe_2O_3 , and 0.89 SiO_2 ; density = 371 lb ft ⁻³ .
3	235	1956	303-1148			97.8 MoSi_2 and 1.4 Fe_2O_3 .
4	95	1961	501-1797	3.0		61.5-63.5 Mo, 35-37 Si; slip cast; measured in a helium atmosphere; density = 362 lb ft ⁻³ .
5	162	1961	728-1783			Single-phase composition; hot pressed.
6	54	1965	300-1200	0.7		Sample supplied by The Carborundum Co.

DATA TABLE NO. 182 SPECIFIC HEAT OF MOLYBDENUM DISILICIDE MoSi_2
 [Temperature, T, K; Specific Heat, C_p , Cal $\text{g}^{-1} \text{K}^{-1}$]

T	C_p	T	C_p	T	C_p
<u>CURVE 1</u>					
273	1.019×10^{-1}	1923	1.268×10^{-1}	1100	1.376×10^{-1}
373	1.060	1073	1.275*	1200	1.430
473	1.098	1148	1.283*		
573	1.134	<u>CURVE 4</u>			
673	1.165	567	9.25×10^{-2}		
773	1.193	595	9.94		
873	1.217	729	1.091×10^{-1}		
973	1.238	811	1.150		
1073	1.256	955	1.255		
1173	1.270	1047	1.322		
<u>CURVE 2</u>					
303	1.018×10^{-1}	1143	1.382		
400	1.095	1249	1.469*		
500	1.142	1364	1.552		
598	1.174	1373	1.558*		
598	1.172*	1471	1.63*		
620	1.172*	1578	1.62		
700	1.206	1690	1.62*		
800	1.230	1797	1.62		
900	1.250	<u>CURVE 5</u>			
1000	1.265	727	1.128×10^{-1}		
1100	1.278	811	1.152*		
1148	1.283	922	1.184		
<u>CURVE 3</u>					
303	1.019×10^{-1} *	1033	1.216		
323	1.039	1144	1.248		
373	1.078*	1255	1.280		
423	1.108	1366	1.312		
473	1.132*	1478	1.344		
523	1.151	1589	1.376		
573	1.167*	1700	1.408*		
598	1.174 [†]	1783	1.432		
598	1.172*	<u>CURVE 6</u>			
623	1.182	300	1.019×10^{-1} *		
673	1.198*	400	1.072		
723	1.212	500	1.131		
773	1.225*	600	1.149		
823	1.236	700	1.183		
873	1.245*	800	1.225		
923	1.254	900	1.273		
973	1.262*	1000	1.323		

* Not shown on plot

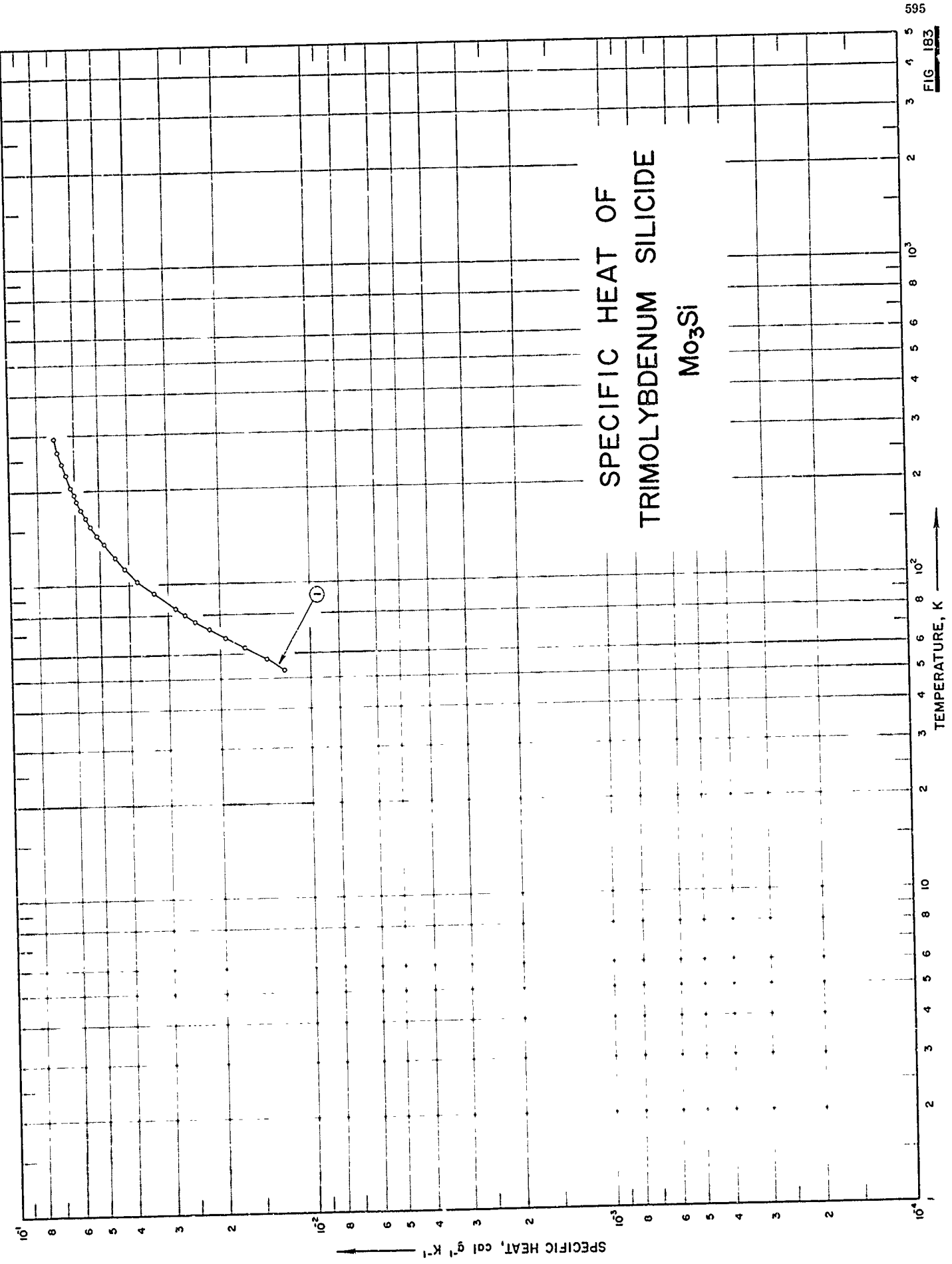

SPECIFICATION TABLE NO. 183 SPECIFIC HEAT OF TRIMOLYBDENUM SILICIDE Mo_3Si

[For Data Reported in Figure and Table No. 183]

Curve No.	Ref. No.	Year	Temp. Range, K	Reported Error, %	Name and Specimen Designation	Composition (weight percent), Specifications and Remarks
1	422	1958	54-295			91.25 Mo and 8.24 Si (91.11 and 8.89 theor.).

DATA TABLE NO. 183 SPECIFIC HEAT OF TRIMOLYBDENUM SILICIDE Mo_3Si [Temperature, T, K; Specific Heat, C_p , Cal $\text{g}^{-1} \text{K}^{-1}$]

T	C_p
	<u>CURVE 1</u>
53.67	1.220×10^{-2}
57.86	1.409
62.71	1.667
67.50	1.931
72.18	2.185
76.97	2.437
80.38	2.617
84.57	2.826
94.56	3.308
104.93	3.762
114.88	4.146
124.50	4.485
136.08	4.850
145.57	5.120
155.87	5.371
165.64	5.577
175.81	5.768
186.45	5.955
195.83	6.085
206.06	6.241
216.19	6.458*
226.22	6.457
236.15	6.571*
245.62	6.657
256.35	6.752*
266.64	6.837
276.14	6.898*
286.38	6.968*
295.99	7.044

* Not shown on plot

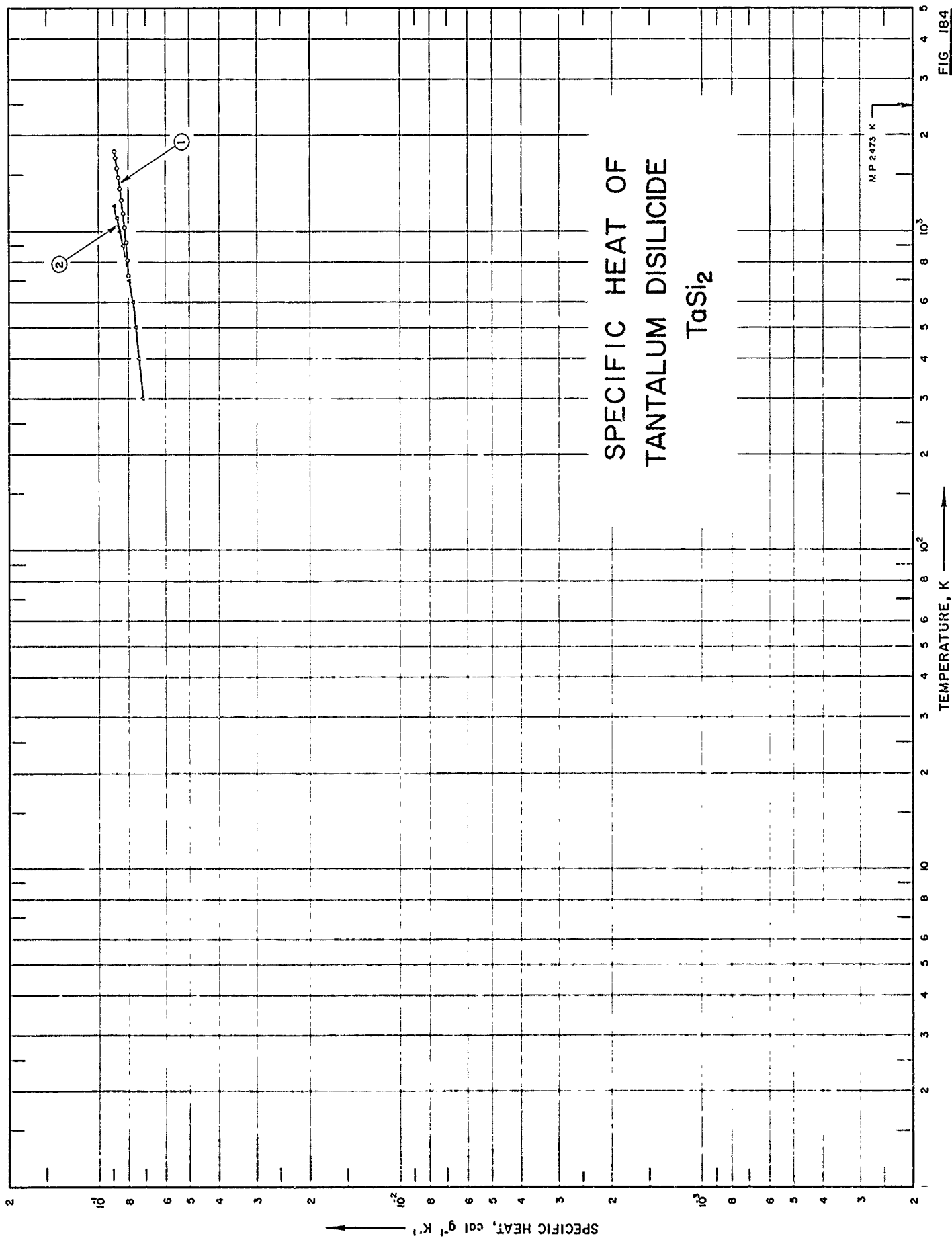

SPECIFICATION TABLE NO. 184 SPECIFIC HEAT OF TANTALUM DISILICIDE TaSi₂

[For Data Reported in Figure and Table No. 184]

Curve No.	Ref. No.	Year	Temp. Range, K	Reported Error, %	Name and Specimen Designation	Composition (weight percent), Specifications and Remarks
1	162	1961	728-1783			Single-phase; prepared by solid-state reaction of constituent elements at 2370 F; hot pressed. 73.40 Ta, 24.35 Si and 1.30 C; sample supplied by The Carbonyl Co.
2	54	1965	300-1200	2.0		

DATA TABLE NO. 184 SPECIFIC HEAT OF TANTALUM DISILICIDE $TaSi_2$
 Temperature, T, K; Specific Heat, C_p , Cal $g^{-1} K^{-1}$

T	C_p
<u>CURVE 1</u>	
728	8.015×10^{-2}
811	8.090
922	8.189
1033	8.289
1144	8.388
1255	8.488
1366	8.587
1478	8.687
1589	8.786
1700	8.886
1783	8.960
<u>CURVE 2</u>	
300	7.152×10^{-2}
400	7.351
500	7.553
600	7.751
700	7.954
800	8.152*
900	8.350
1000	8.553
1100	8.751
1200	8.953

* Not shown on plot

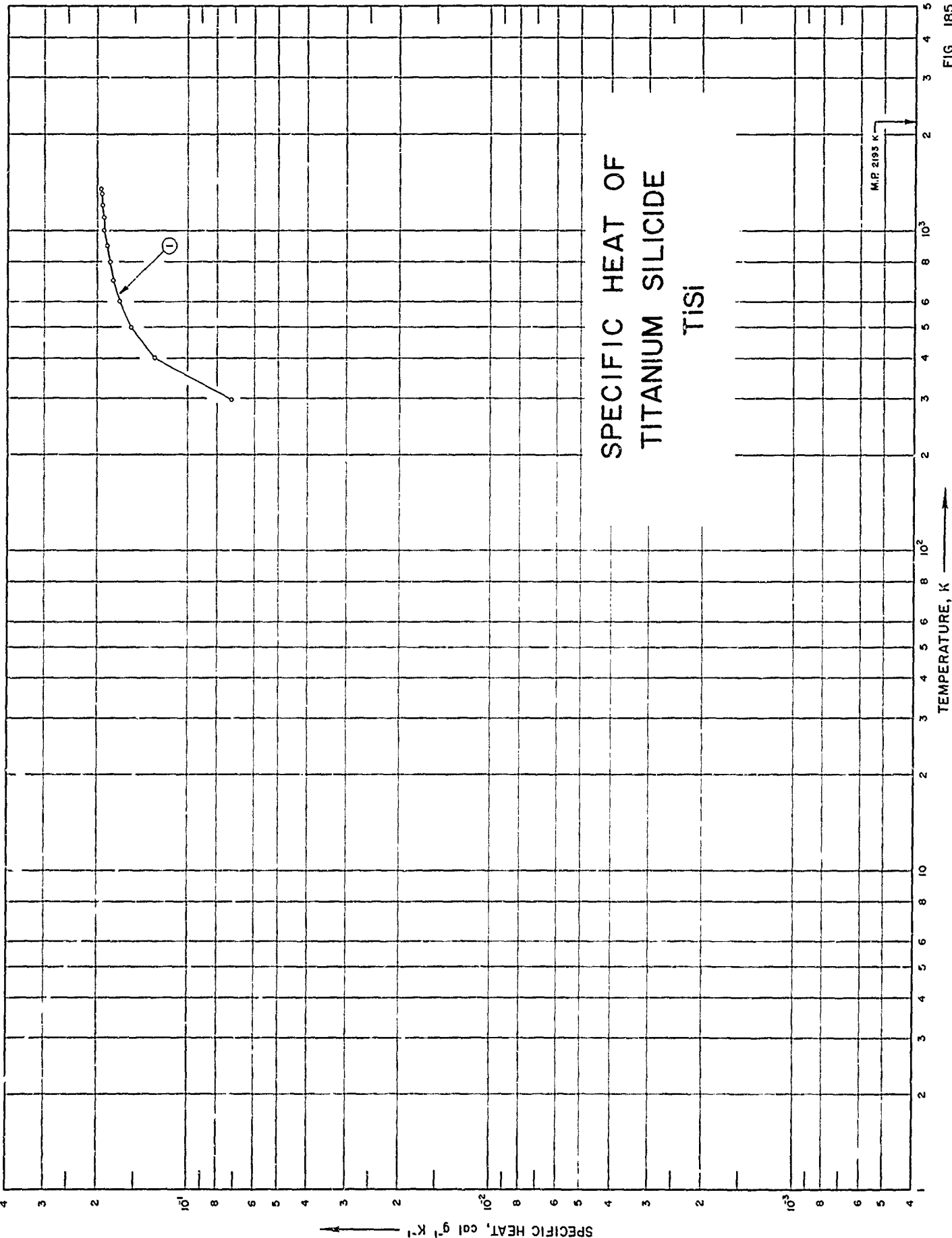

FIG. 185

TEMPERATURE, K

SPECIFIC HEAT, cal g⁻¹ K⁻¹

SPECIFICATION TABLE NO. 185 SPECIFIC HEAT OF TITANIUM SILICIDE TISI

[For Data Reported in Figure and Table No. 185]

Curve No.	Ref. No.	Year	Temp. Range, K	Reported Error, %	Name and Specimen Designation	Composition (weight percent), Specifications and Remarks
1	236	1959	298-1350	±1.8		

DATA TABLE NO. 185 SPECIFIC HEAT OF TITANIUM SILICIDE TISI
 [Temperature, T, K; Specific Heat, C_p , Cal $g^{-1} K^{-1}$]

T	C_p
<u>CURVE 1</u>	
298.15	7.230×10^{-2}
300	7.352*
400	1.304×10^{-1}
500	1.566
600	1.707
700	1.794
800	1.849
900	1.887
1000	1.915
1100	1.934
1200	1.950
1300	1.962
1350	1.966

* Not shown on plot

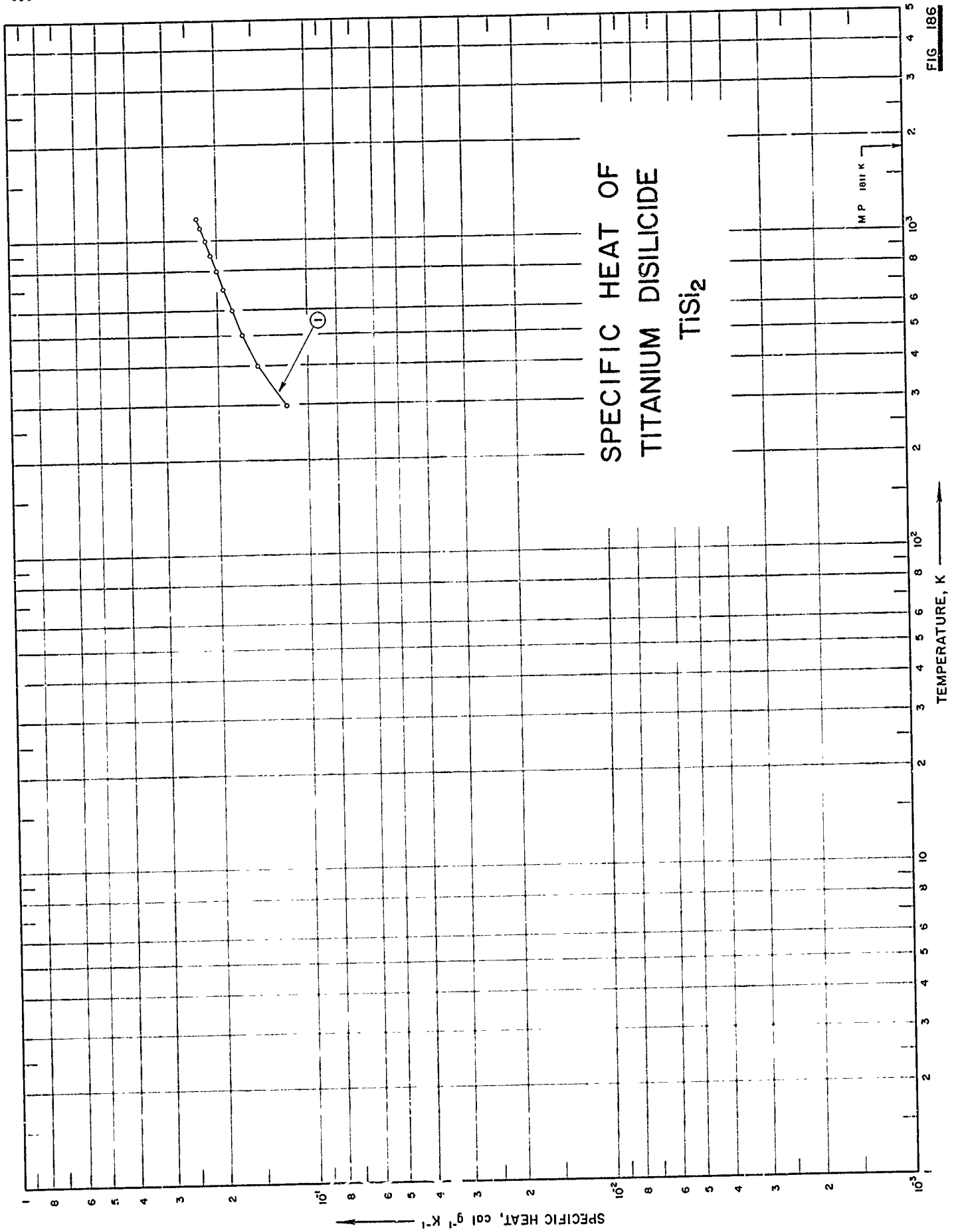

FIG. 186

SPECIFICATION TABLE NO. 186 SPECIFIC HEAT OF TITANIUM DISILICIDE $TiSi_2$

[For Data Reported in Figure and Table No. 186]

Curve No.	Ref. No.	Year	Temp. Range, K	Reported Error, %	Name and Specimen Designation	Composition (weight percent), Specifications and Remarks
1	236	1958	298-1180	± 1.9		

DATA TABLE NO. 186 SPECIFIC HEAT OF TITANIUM DISILICIDE TiSi_2
 [Temperature, T, K; Specific Heat, C_p , Cal $\text{g}^{-1} \text{K}^{-1}$]

T	C_p
<u>CURVE 1</u>	
298.15	1.182×10^{-1}
300	1.189*
400	1.482
500	1.660
600	1.793
700	1.906
800	2.006
900	2.101
1000	2.191
1100	2.279
1180	2.347

* Not shown on plot

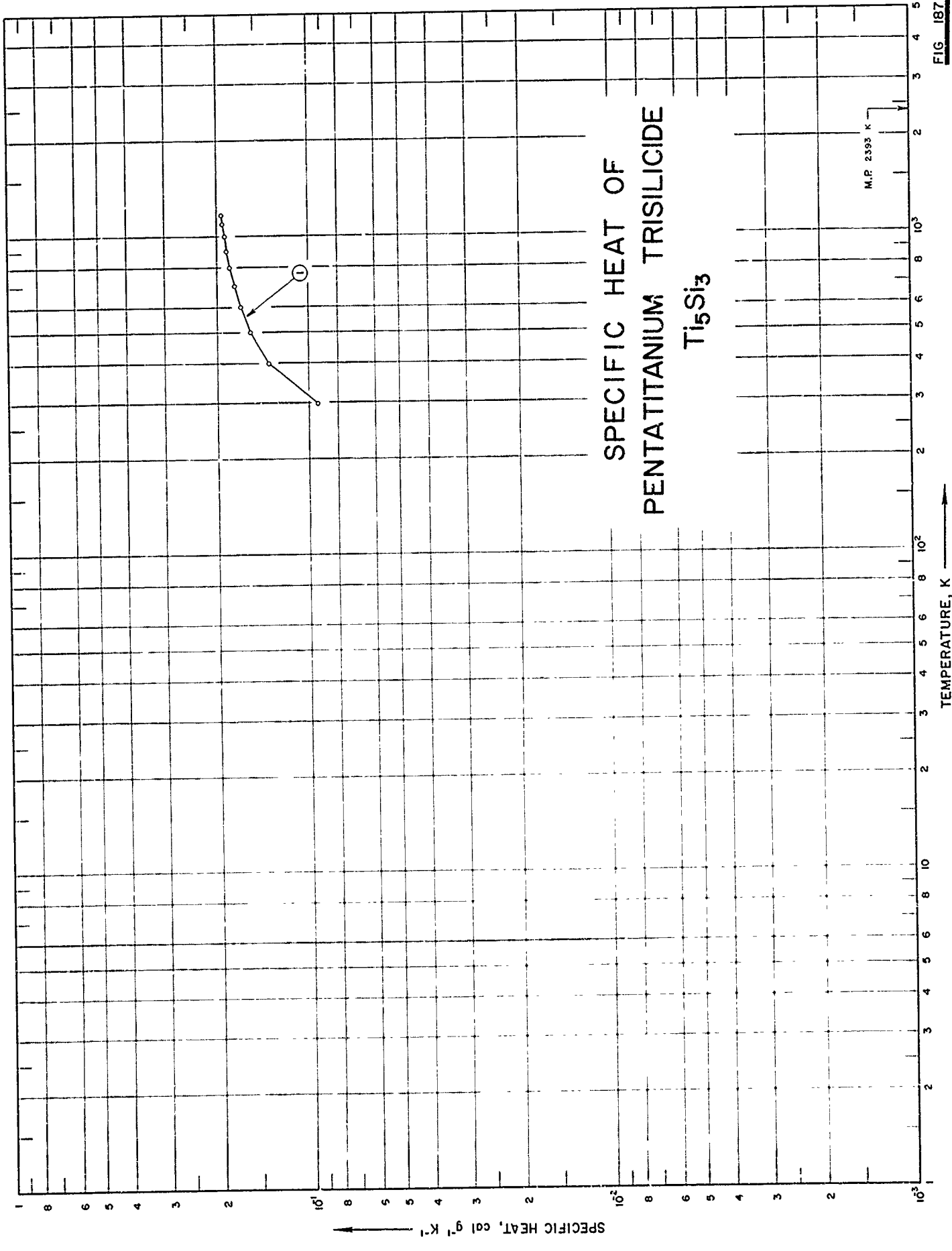

FIG. 187

SPECIFICATION TABLE NO. 187 SPECIFIC HEAT OF PENTATITANIUM TRISILICIDE Ti_5Si_3

[For Data Reported in Figure and Table No. 187]

Curve No.	Ref. No.	Year	Temp. Range, K	Reported Error, %	Name and Specimen Designation	Composition (weight percent), Specifications and Remarks
1	236	1958	298-1170	±3.0		

DATA TABLE NO. 187 SPECIFIC HEAT OF PENTATITANIUM TRISILICIDE Ti_5Si_3 [Temperature, T, K; Specific Heat, C_p , Cal g⁻¹ K⁻¹]

T	C_p
298.15	9.318×10^{-2}
300	9.433*
400	1.358×10^{-1}
500	1.560
600	1.678
700	1.756
800	1.812
900	1.857
1000	1.894
1100	1.926
1170	1.946

CURVE 1

* Not shown on plot

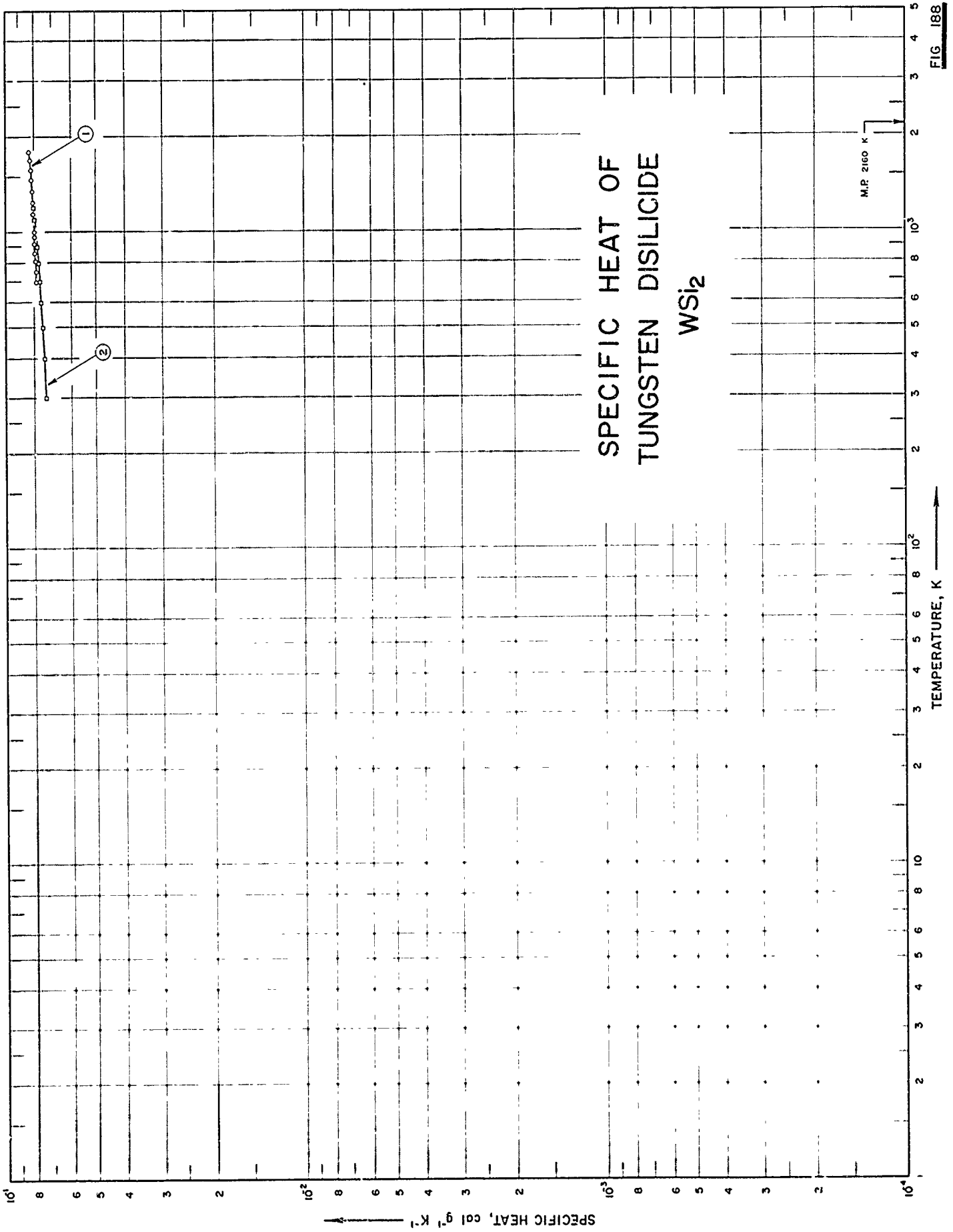

FIG. 188

SPECIFICATION TABLE NO. 188 SPECIFIC HEAT OF TUNGSTEN DISILICIDE WSi_2

[For Data Reported in Figure and Table No. 188]

Curve No.	Ref. No.	Year	Temp. Range, K	Reported Error, %	Name and Specimen Designation	Composition (weight percent), Specifications and Remarks
1	162	1961	700-1794			Single-phase; prepared by solid-state reaction of constituent elements at 2370 F; hot pressed. 75.97 W and 23.3% Si; sample supplied by The Carborundum Co.
2	54	1965	300-1200	1.7		

DATA TABLE NO. 188 SPECIFIC HEAT OF TUNGSTEN DISILICIDE WSi_2 [Temperature, T, K; Specific Heat, C_p , Cal $g^{-1}K^{-1}$]

T	C_p
<u>CURVE 1</u>	
700	7.959×10^{-2}
755	7.978
811	7.997
866	8.016
922	8.035
978	8.054
1033	8.073
1089	8.091*
1144	8.110
1200	8.129*
1255	8.148
1311	8.167*
1366	8.186
1422	8.205*
1478	8.224
1533	8.243*
1589	8.262
1644	8.281*
1700	8.300
1755	8.319*
1794	8.332

T	C_p
<u>CURVE 2</u>	
300	7.366×10^{-2}
400	7.453
500	7.541
600	7.628
700	7.716
800	7.803
900	7.891
1000	7.978*
1100	8.066
1200	8.158

* Not shown on plot

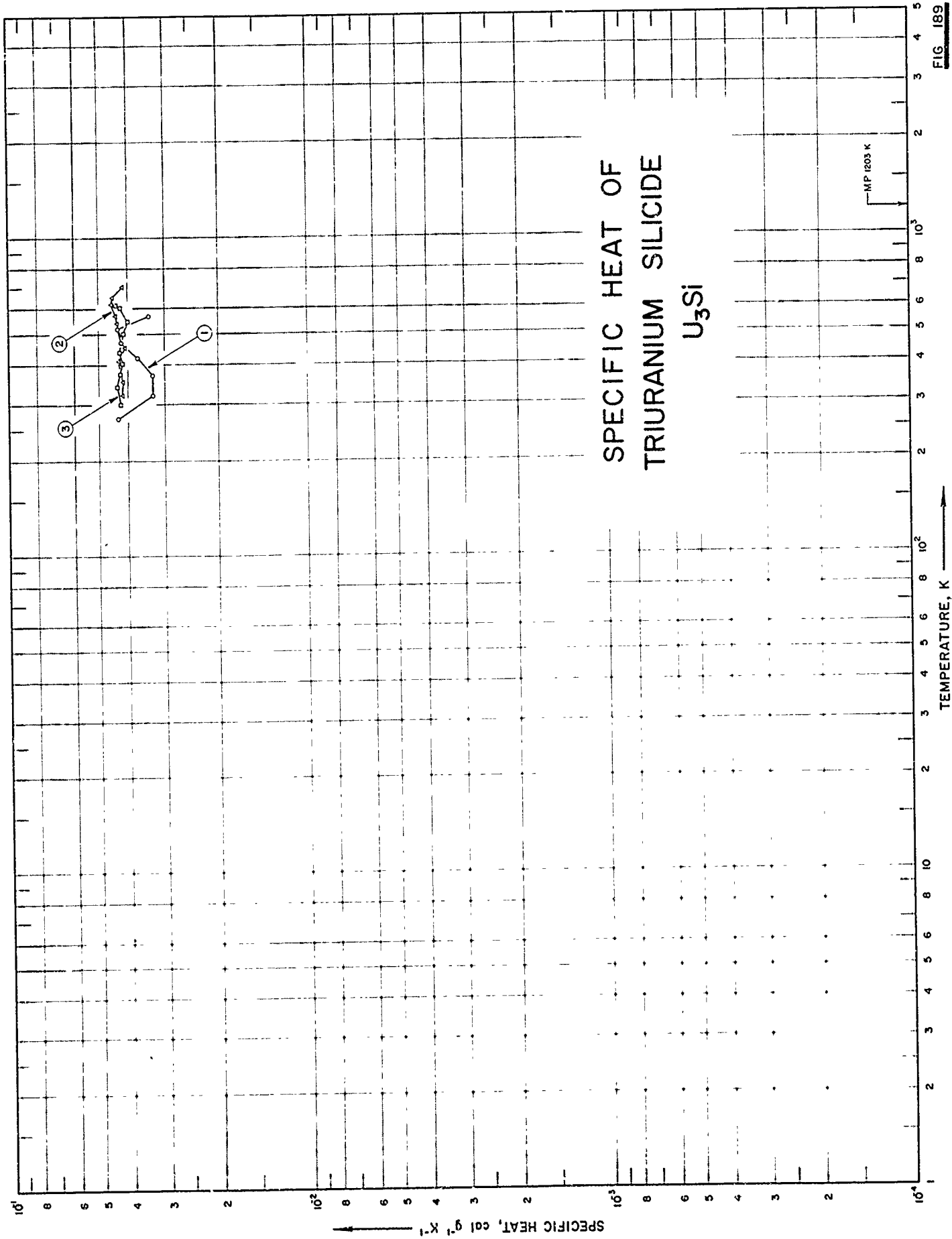

SPECIFICATION TABLE NO. 189 SPECIFIC HEAT OF TRURANIUM SILICIDE U_3Si

[For Data Reported in Figure and Table No. 189]

Curve No.	Ref. No.	Year	Temp. Range, K	Reported Error, %	Name and Specimen Designation	Composition (weight percent), Specifications and Remarks
1	237	1957	273-573			0.05 Fe, 0.01 Al, Mn, and <0.01 each of others; sintered.
2	195	1963	324-708	5.0	Sample 535	96.1 U, 3.9 Si, prepared by arc melting and casting uranium and silicon; annealed for 24 hrs at 800 C; density = 894 lb ft ⁻³ .
3	195	1963	307-621	5.0	Sample 533	96.9 U, 3.9 Si; prepared by arc melting and casting uranium and silicon; annealed for 24 hrs at 800 C; density = 905 lb ft ⁻³ .

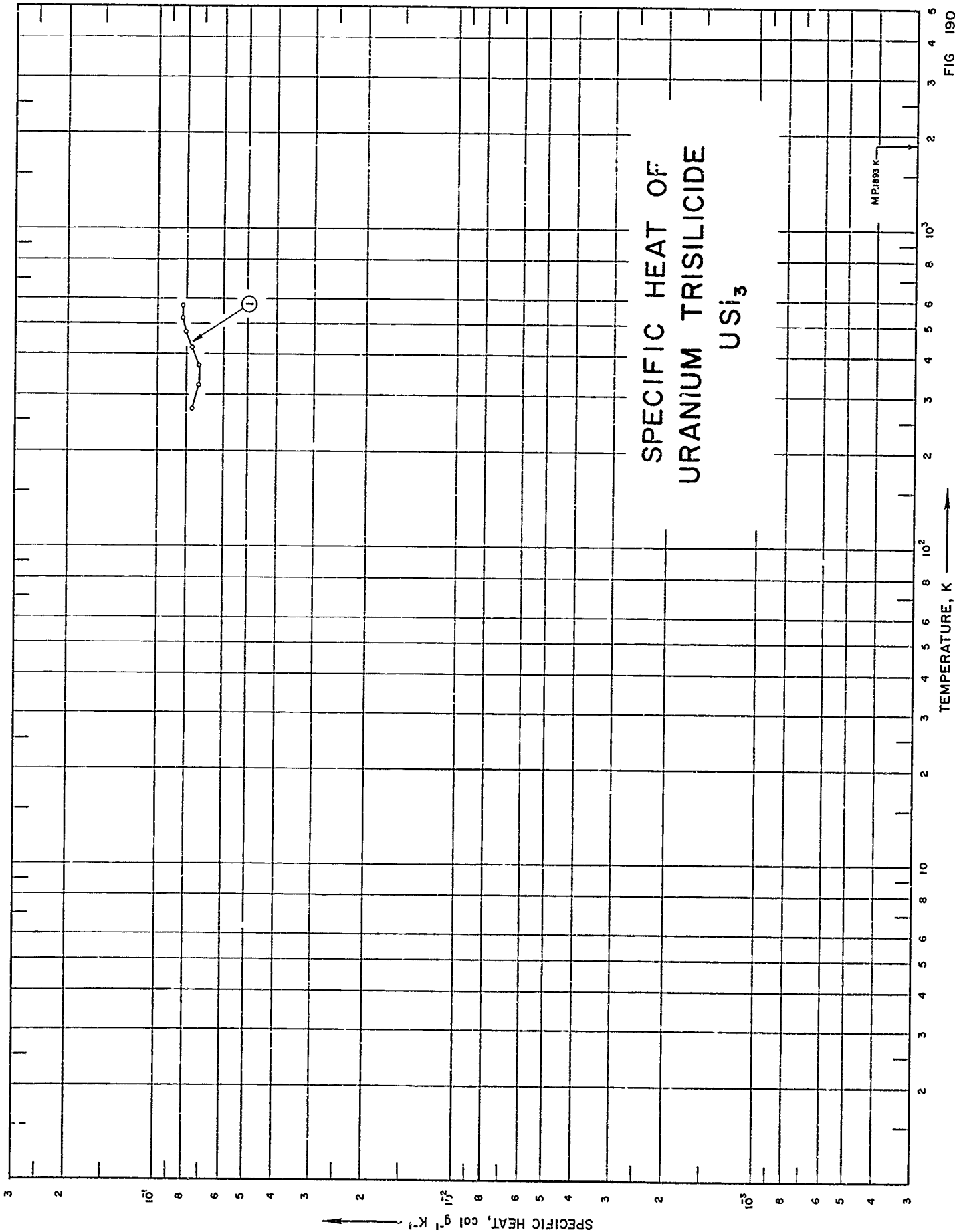

FIG. 190

SPECIFICATION TABLE NO. 190 SPECIFIC HEAT OF URANIUM TRISILICIDE USi_3

[For Data Reported in Figure and Table No. 190]

Curve No.	Ref. No.	Year	Temp. Range, K	Reported Error, %	Name and Specimen Designation	Composition (weight percent), Specifications and Remarks
1	237	1957	273-573			1.0 W, 0.3 Fe, 0.09 Al, 0.05 Cu, and <0.01 others; sintered.

DATA TABLE NO. 190 SPECIFIC HEAT OF URANIUM TRISILICIDE USi_3
[Temperature, T , K; Specific Heat, C_p , Cal $g^{-1}K^{-1}$]

T	C_p
273	7.7×10^{-2}
323	7.3
373	7.3
423	7.7
473	8.1
523	8.3
573	8.3

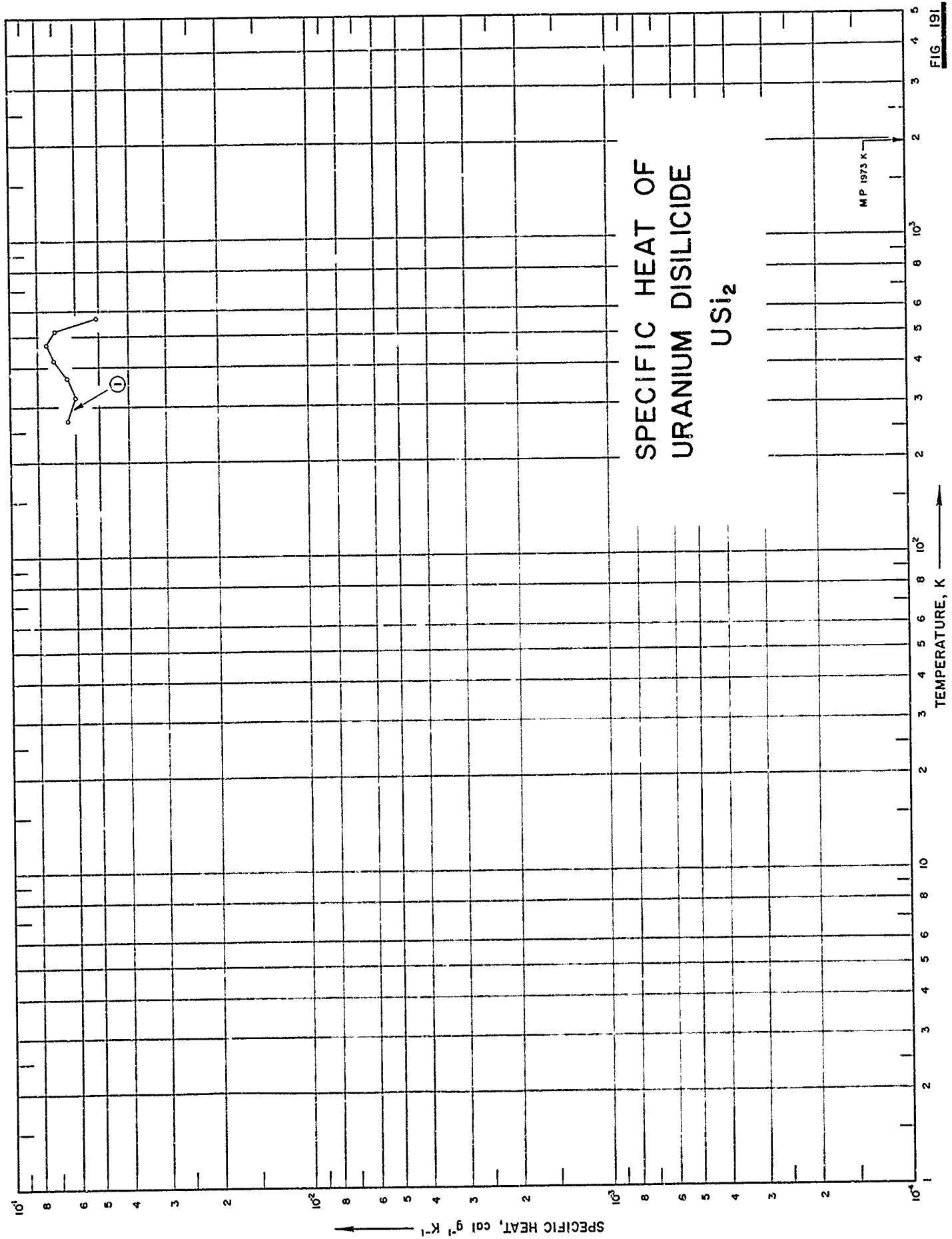

FIG. 191

SPECIFICATION TABLE NO. 191 SPECIFIC HEAT OF URANIUM DISILICIDE USi_2

[For Data Reported in Figure and Table No. 191]

Curve No.	Ref. No.	Year	Temp. Range, K	Reported Error, %	Name and Specimen Designation	Composition (weight percent), Specifications and Remarks
1	237	1957	273-573			0.08 Fe, 0.07 Al, 0.03 Cu, and <0.01 each of others; sintered.

DATA TABLE NO. 191 SPECIFIC HEAT OF URANIUM DISILICIDE USi_2 [Temperature, T, K; Specific Heat, C_p , Cal $g^{-1} K^{-1}$]

T	C_p
<u>CURVE 1</u>	
273	6.4×10^{-2}
323	6.0
373	6.4
423	7.1
473	7.5
523	7.0
573	5.1

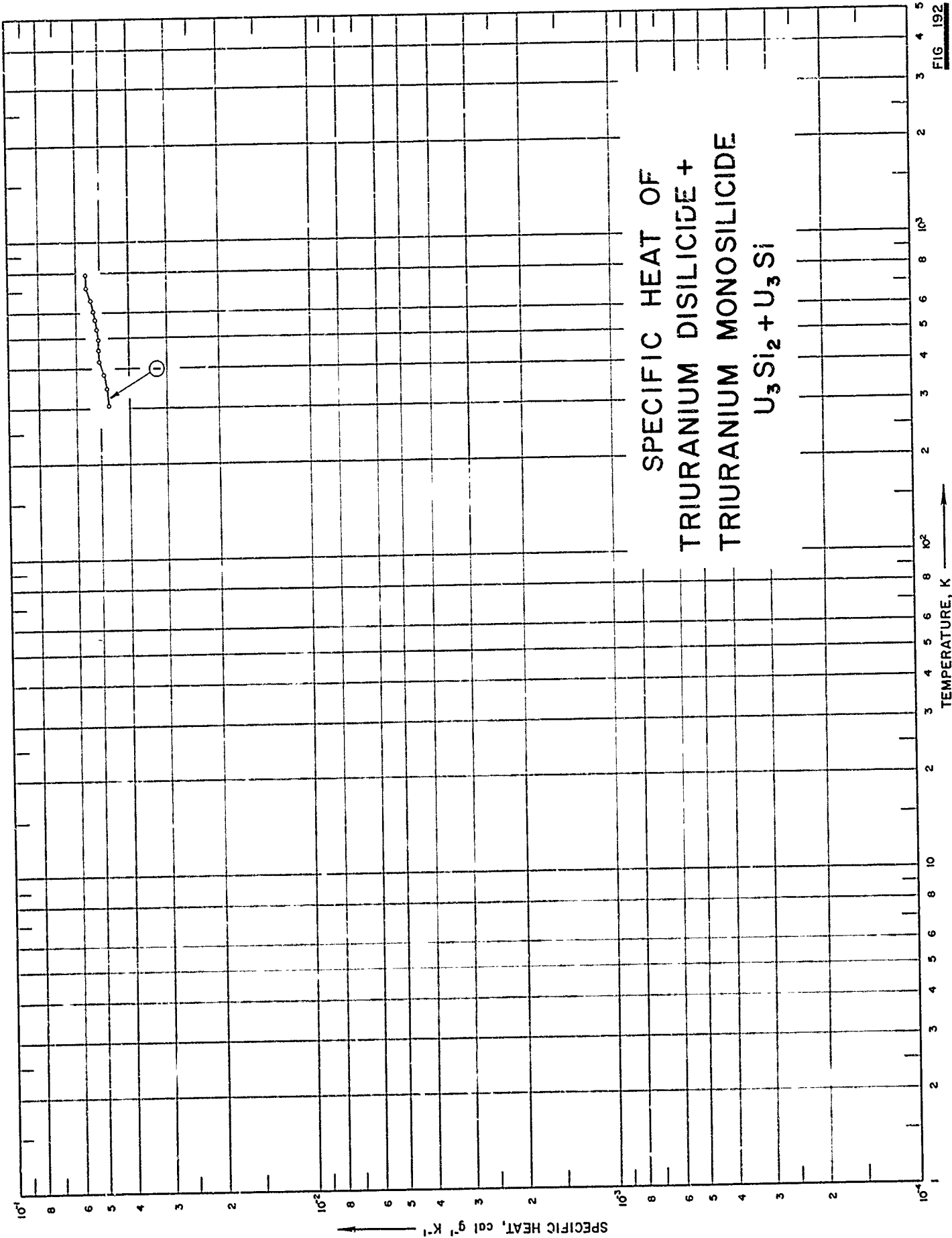

FIG. 192

SPECIFICATION TABLE NO. 192 SPECIFIC HEAT OF TRIURANIUM DISILICIDE + TRIURANIUM MONOSILICIDE $U_3Si_2 + U_3Si$

[For Data Reported in Figure and Table No. 192]

Curve No.	Ref. No.	Year	Temp. Range, K	Reported Error, %	Name and Specimen Designation	Composition (weight percent), Specifications and Remarks
1	195	1963	308-795	±5.0	Sample 539	93.9 U and 6.1 Si; prepared by arc melting and casting uranium and silicon; annealed for 24 hrs at 800 C; density = 805 lb ft ⁻³ .

DATA TABLE NO. 192 SPECIFIC HEAT OF TRIURANIUM DISILICIDE + TRIURANIUM MONOSILICIDE $U_3Si_2 + U_3Si$
 [Temperature, T, K; Specific Heat, C_p , Cal $g^{-1} K^{-1}$]

T	C_p	T	C_p
Series 1			
308	4.690×10^{-2}	615	4.900×10^{-2}
328	4.720*	635	4.950
347	4.750	655	4.990
367	4.810*	674	5.010
385	4.890	694	5.020
404	4.970*	714	5.020
423	5.030	734	5.040
441	5.050*	754	5.120
460	5.050*	773	5.280
479	5.050*	792	5.510
498	5.050*		
517	5.080*		
535	5.110		
554	5.160*		
573	5.190		
591	5.210*		
610	5.230		
629	5.250*		
648	5.290*		
666	5.350		
685	5.490*		
703	5.510*		
721	5.520		
739	5.510*		
758	5.500*		
776	5.500*		
795	5.510		
Series 2*			
337	4.500×10^{-2}	349	4.710×10^{-2}
357	4.510	369	4.730
377	4.520	389	4.780
397	4.560	408	4.800
417	4.630	428	4.840
436	4.700	447	4.880
456	4.750	467	4.900
476	4.770	487	4.930
495	4.770	506	4.960
515	4.760	526	4.970
535	4.760	545	4.980
555	4.770	565	5.000
575	4.800	586	5.020
595	4.840	606	5.040
		625	5.070
		645	5.100
		664	5.150
		684	5.200
		693	5.260

* Not shown on plot

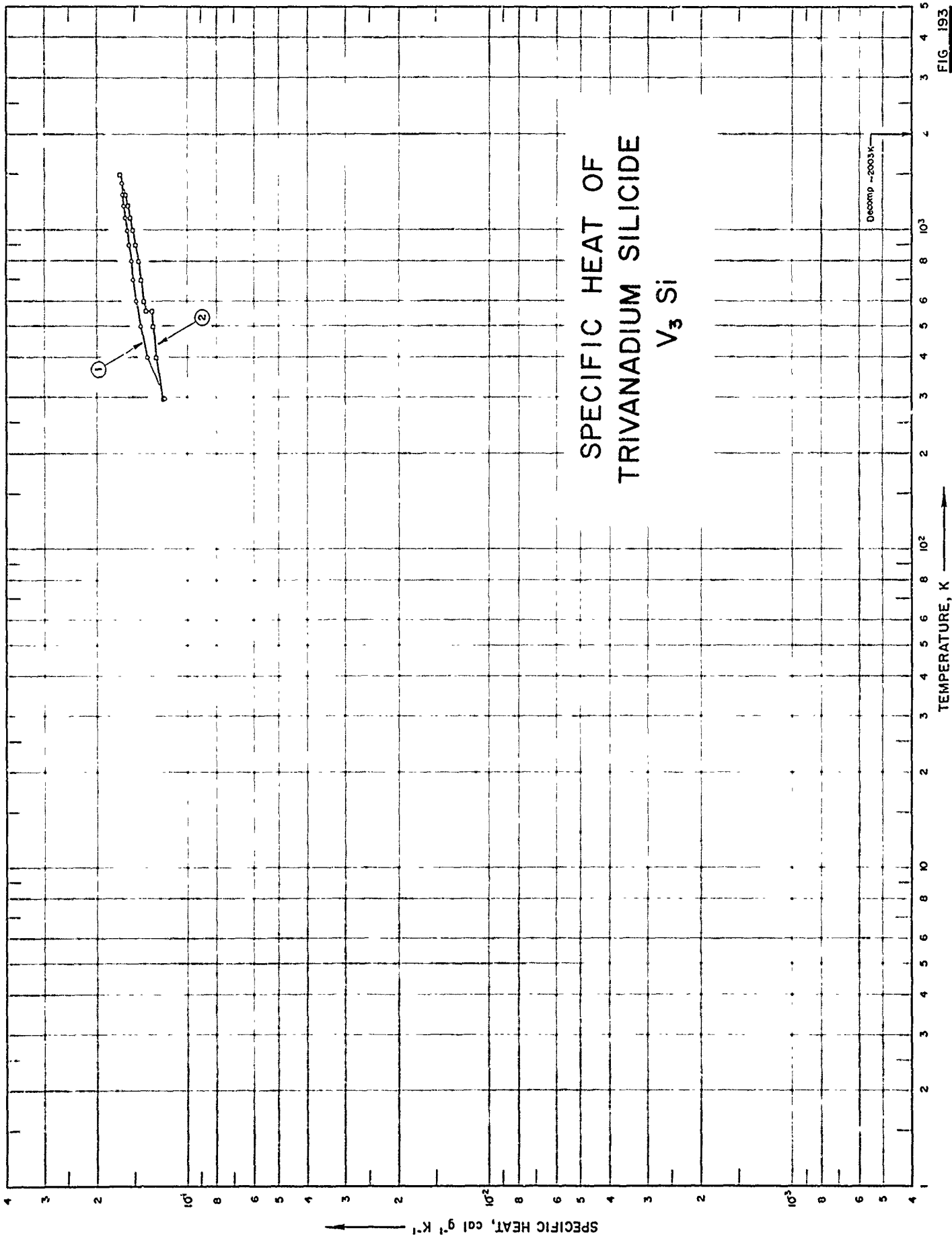

FIG 193

SPECIFICATION TABLE NO. 193 SPECIFIC HEAT OF TRIVANADIUM SILICIDE V_3Si

[For Data Reported in Figure and Table No. 193]

Curve No.	Ref. No.	Year	Temp. Range, K	Reported Error, %	Name and Specimen Designation	Composition (weight percent), Specifications and Remarks
1	238	1962	298-1310	±2.2		~98.0 V_3Si .
2	239	1963	298-1500	0.10		~99.0 V_3Si , impurities 1.0 V_5Si_3 ; crystalline.

DATA TABLE NO. 193 SPECIFIC HEAT OF TRIVANADIUM SILICIDE V_3Si [Temperature, T, K; Specific Heat, C_p , Cal $g^{-1} K^{-1}$]

T	C_p
<u>CURVE 1</u>	
298	1.196 x 10^{-1}
300	1.200*
400	1.354
500	1.432
600	1.482
700	1.518
800	1.547
900	1.571
1000	1.593
1100	1.613
1200	1.632
1300	1.651
1310	1.653
<u>CURVE 2</u>	
298.15	1.2072 x 10^{-1}
300	1.2091*
400	1.2758
500	1.3666
560	1.3177
560	1.3823
600	1.3951
700	1.4270
800	1.4590
900	1.4909
1000	1.5299
1100	1.5548
1200	1.5868
1300	1.6187
1400	1.6507*
1500	1.6826

* Not shown on plot

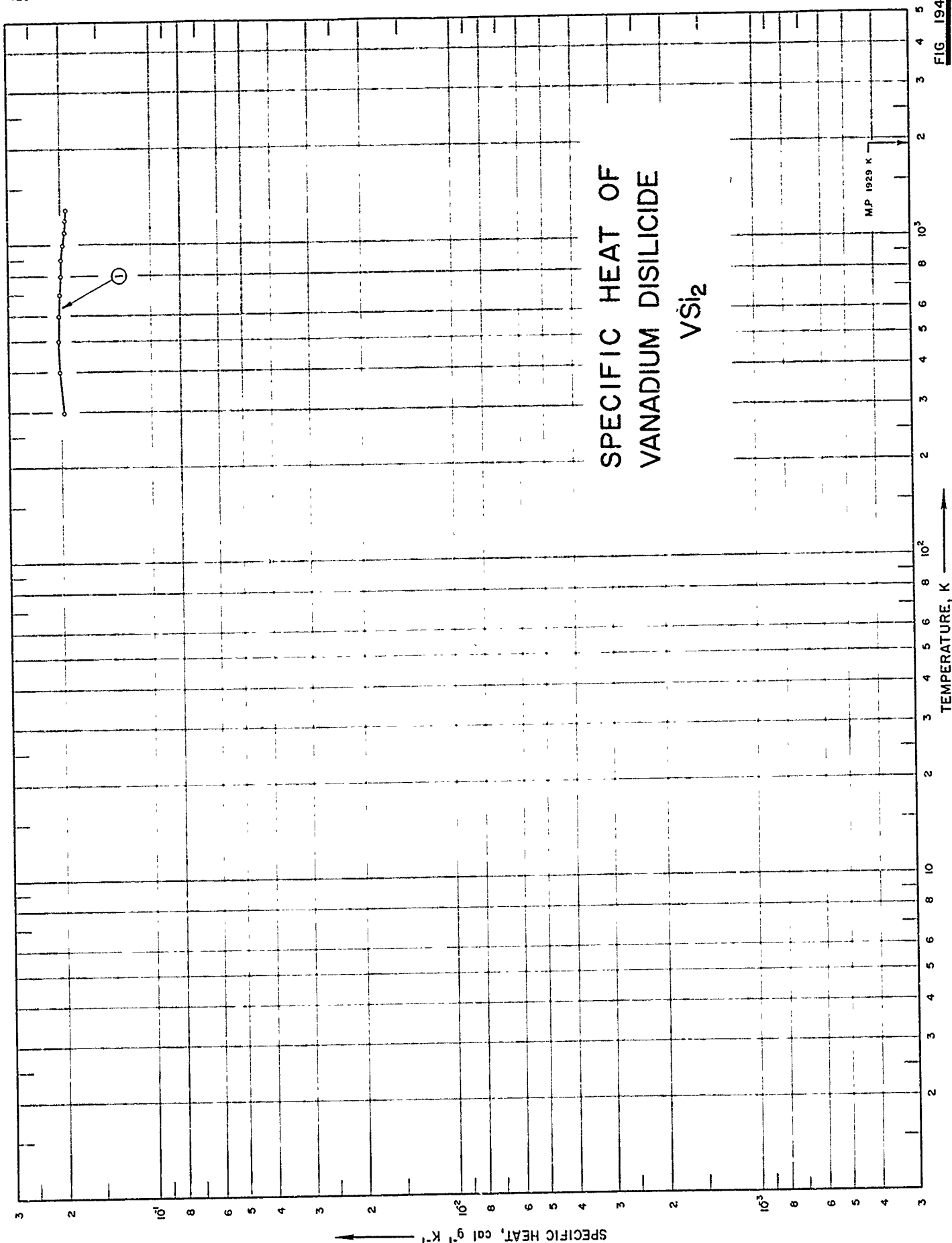

FIG 194

SPECIFICATION TABLE NO. 194 SPECIFIC HEAT OF VANADIUM DISILICIDE VSi_2

[For Data Reported in Figure and Table No. 194]

Curve No.	Ref. No.	Year	Temp. Range, K	Reported Error, %	Name and Specimen Designation	Composition (weight percent), Specifications and Remarks
1	238	1962	290-1290	±1.2		~98.0 VSi_2 .

DATA TABLE NO. 194 SPECIFIC HEAT OF VANADIUM DISILICIDE VS_i_2
[Temperature, T, K; Specific Heat, C_p , Cal $g^{-1} K^{-1}$]

T	C_p
<u>CURVE 1</u>	
298	1.957 x 10 ⁻¹
300	1.958*
400	2.006
500	2.017
600	2.014
700	2.004
800	1.990
900	1.975
1000	1.957
1100	1.939
1200	1.921
1290	1.904

* Not shown on plot

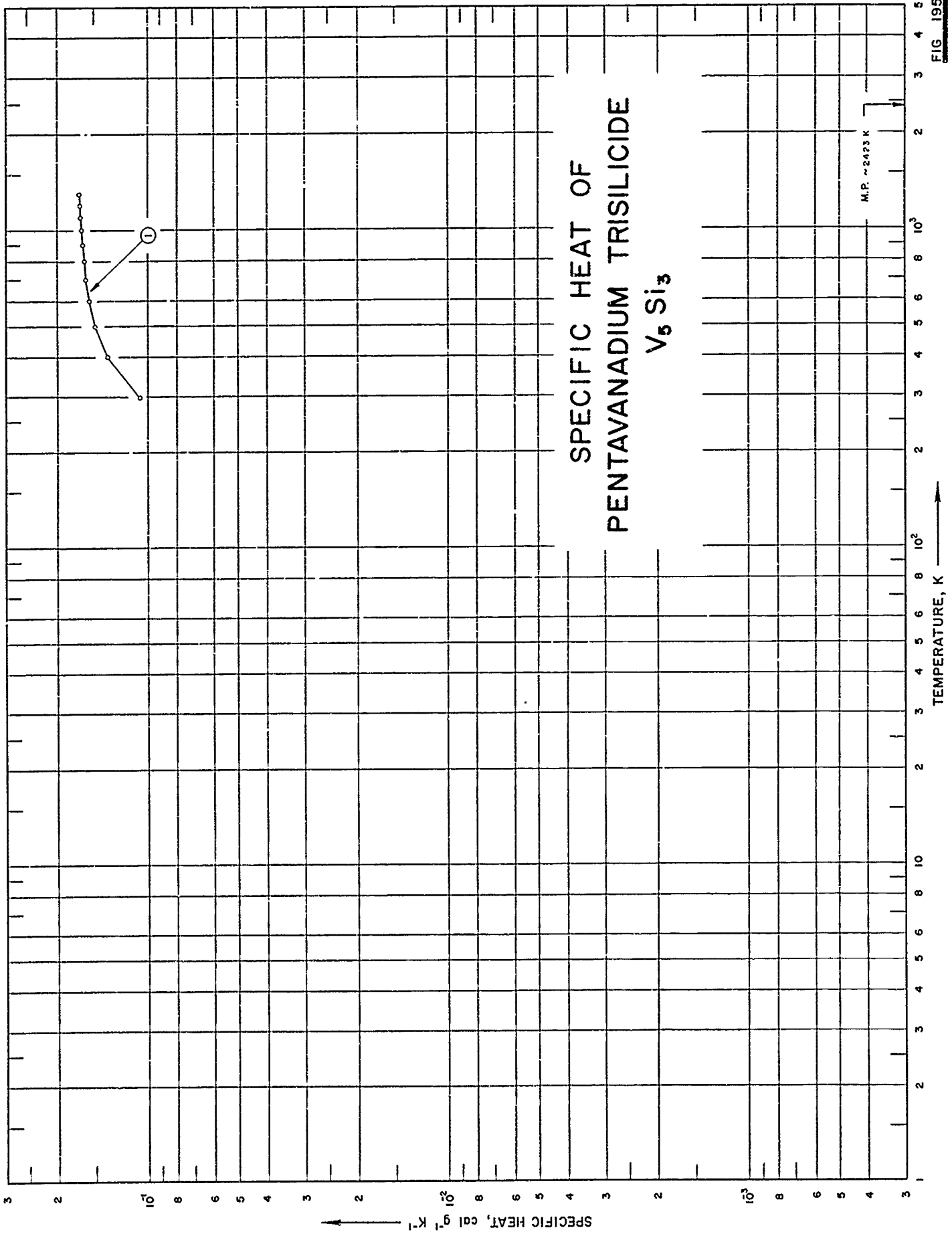

SPECIFICATION TABLE NO. 195 SPECIFIC HEAT OF PENTAVANADIUM TRISILICIDE V_5Si_3

[For Data Reported in Figure and Table No. 195]

Curve No.	Ref. No.	Year	Temp. Range, K	Reported Error, %	Name and Specimen Designation	Composition (weight percent), Specifications and Remarks
1	238	1962	298-1290	±1.9		~98.0 V_5Si_3 .

DATA TABLE NO. 195 SPECIFIC HEAT OF PENTAVANADIUM TRISILICIDE V_5Si_3 [Temperature, T, K; Specific Heat, C_p , Cal $g^{-1} K^{-1}$]

T	C_p
<u>CURVE 1</u>	
298	1.061×10^{-1}
300	1.070*
400	1.356
500	1.490
600	1.562
700	1.605
800	1.635
900	1.654
1000	1.668
1100	1.680
1200	1.688
1290	1.694

* Not shown on plot

FIG 196

SPECIFIC HEAT OF
DIANTIMONY TRISULFIDE
 Sb_2S_3

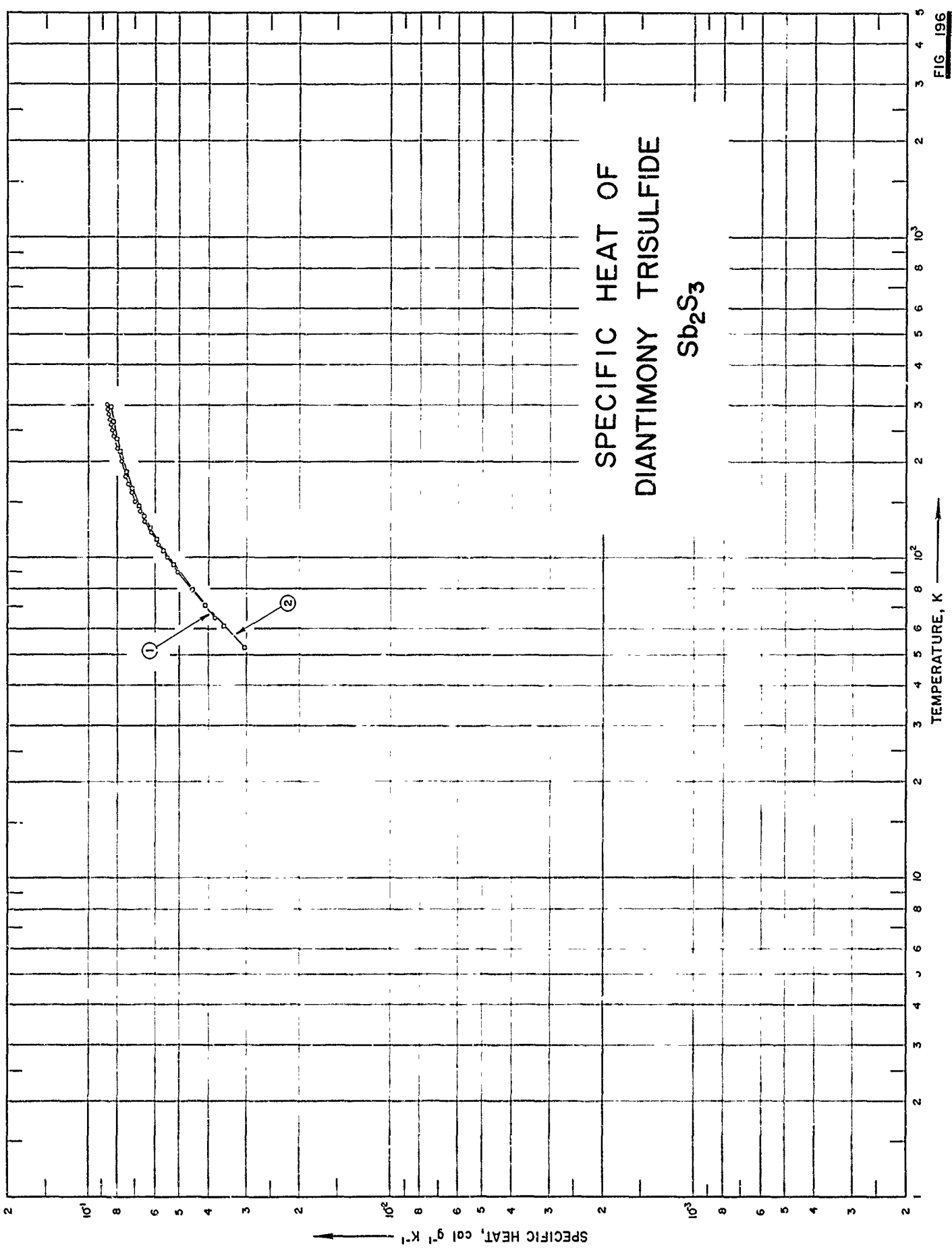

PRECEDING PAGE BLANK-NOT FILMED

SPECIFICATION TABLE NO. 196 SPECIFIC HEAT OF DIANTIMONY TRISULFIDE Sb_2S_3

[For Data Reported in Figure and Table No. 196]

Curve No.	Ref. No.	Year	Temp. Range, K	Reported Error, %	Name and Specimen Designation	Composition (weight percent), Specifications and Remarks
1	28	1960	65-300			Probably pure.
2	338	1962	53-296	0.3		71.73 Sb and 28.33S; mixture of pure antimony and sulfur was heated slowly to 450 C; held at 450 C for 7 days; cooled to room temperature.

DATA TABLE NO. 196 SPECIFIC HEAT OF DIANTIMONY TRISULFIDE Sb_2S_3
 [Temperature, T, K; Specific Heat, C_p , Cal $g^{-1}K^{-1}$]

T	C_p	
	CURVE 1	CURVE 2 (cont.)
65	3.83×10^2	7.498×10^2
70	4.09*	7.622*
80	4.55*	7.845
90	5.08	7.951*
100	5.49	8.028
110	5.86	8.090*
120	6.20	8.178*
130	6.52	8.246
140	6.78	8.293*
150	7.02	8.364*
160	7.20	8.425
170	7.36	
180	7.51	
190	7.64*	
200	7.76	
210	7.89*	
220	8.01	
230	8.11*	
240	8.20	
250	8.32	
260	8.39	
270	8.46	
280	8.54	
290	8.62	
300	8.68	

T	C_p	
	CURVE 1	CURVE 2
52.55	3.059×10^2	
56.77	3.297*	
61.37	3.562	
66.22	3.836*	
71.19	4.110	
76.05	4.357*	
79.85	4.548	
84.29	4.751*	
95.00	5.234	
105.30	5.646	
114.52	5.952	
124.58	6.267	
135.85	6.565	
145.56	6.803	
155.73	7.021*	
165.91	7.198	
176.06	7.360*	

* Not shown on plot

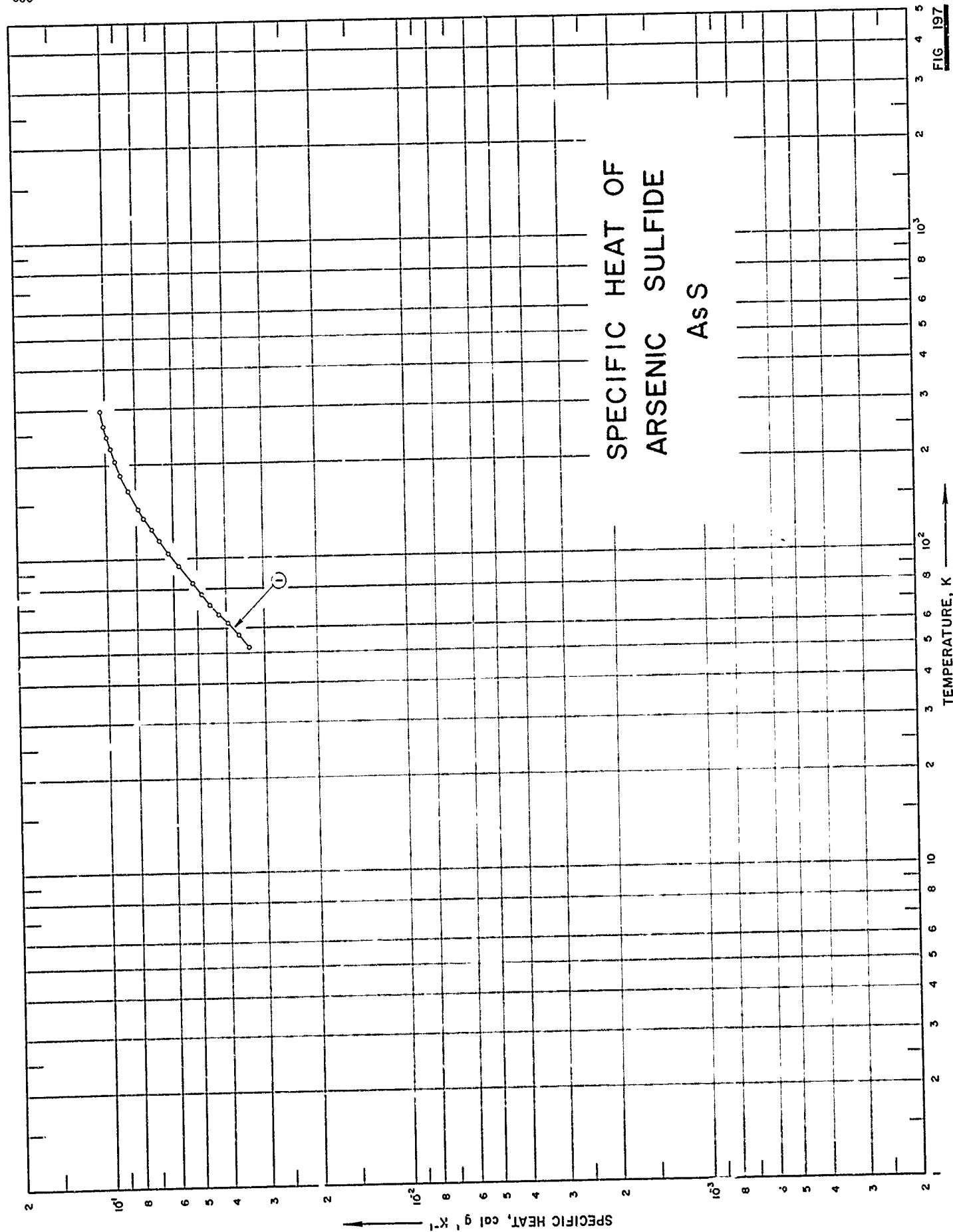

FIG 197

SPECIFICATION TABLE NO. 197 SPECIFIC HEAT OF ARSENIC SULFIDE AsS

[For Data Reported in Figure and Table No. 197]

Curve No.	Ref. No.	Year	Temp. Range, K	Reported Error, %	Name and Specimen Designation	Composition (weight percent), Specifications and Remarks
1	339	1964	52-296	≤ 0.3		70.12 As and 30.01 S, (70.03 and 29.97 theo); prepared from pure arsenic and sulfur by reacting them at 310 C.

DATA TABLE NO. 197 SPECIFIC HEAT OF ARSENIC SULFIDE As_2S_3
 [Temperature, T, K; Specific Heat, C_p , Cal $\text{g}^{-1}\text{K}^{-1}$]

T	C_p
CURVE 1	
52.34	3.383×10^{-2}
57.01	3.665
62.15	3.992
66.93	4.267
71.94	4.557
77.05	4.853
79.88	5.009*
83.62	5.205
94.91	5.791
104.85	6.279
114.53	6.714
124.57	7.137
135.74	7.562
145.46	7.892
155.77	8.216*
166.03	8.496
175.93	8.747*
186.19	8.985
195.91	9.166*
206.18	9.365
217.27	9.552*
226.33	9.692
236.00	9.833*
245.82	9.964
255.46	$1.009 \times 10^{-1*}$
266.42	1.019
276.58	1.030*
286.79	1.040*
296.30	1.049

* Not shown on plot

SPECIFIC HEAT OF
DIARSENIC TRISULFIDE
 As_2S_3

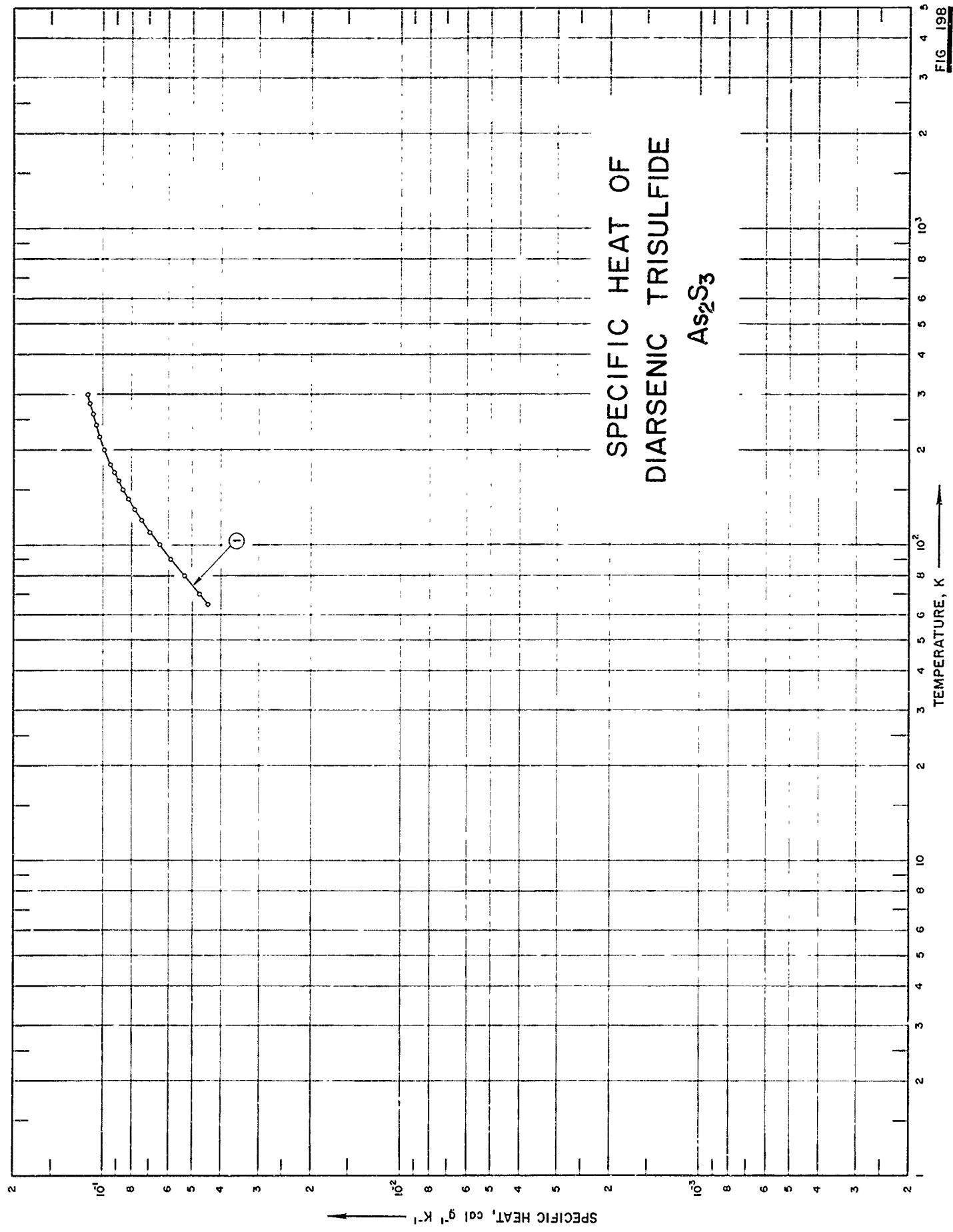

SPECIFICATION TABLE NO. 198 SPECIFIC HEAT OF DIARSENIC TRISULFIDE As_2S_3

[For Data Reported in Figure and Table No. 198]

Curve No.	Ref. No.	Year	Temp. Range, K	Reported Error, %	Name and Specimen Designation	Composition (weight percent), Specifications and Remarks
1	28	1960	65-300			Probably pure.

DATA TABLE NO. 198 SPECIFIC HEAT OF DIARSENIC TRISULFIDE As_2S_3 [Temperature, T, K; Specific Heat, C_p , Cal $g^{-1}K^{-1}$]

T	C_p
CURVE 1	
65	4.43×10^{-2}
70	4.74
80	5.32
90	5.93
100	6.48
110	6.97
120	7.44
130	7.84
140	8.23
150	8.58
160	8.88
170	9.19
180	9.47
190	9.71*
200	9.92
210	1.01×10^{-1}
220	1.03
230	1.04*
240	1.06
250	1.07*
260	1.08
270	1.09*
280	1.11
290	1.12*
300	1.13

* Not shown on plot

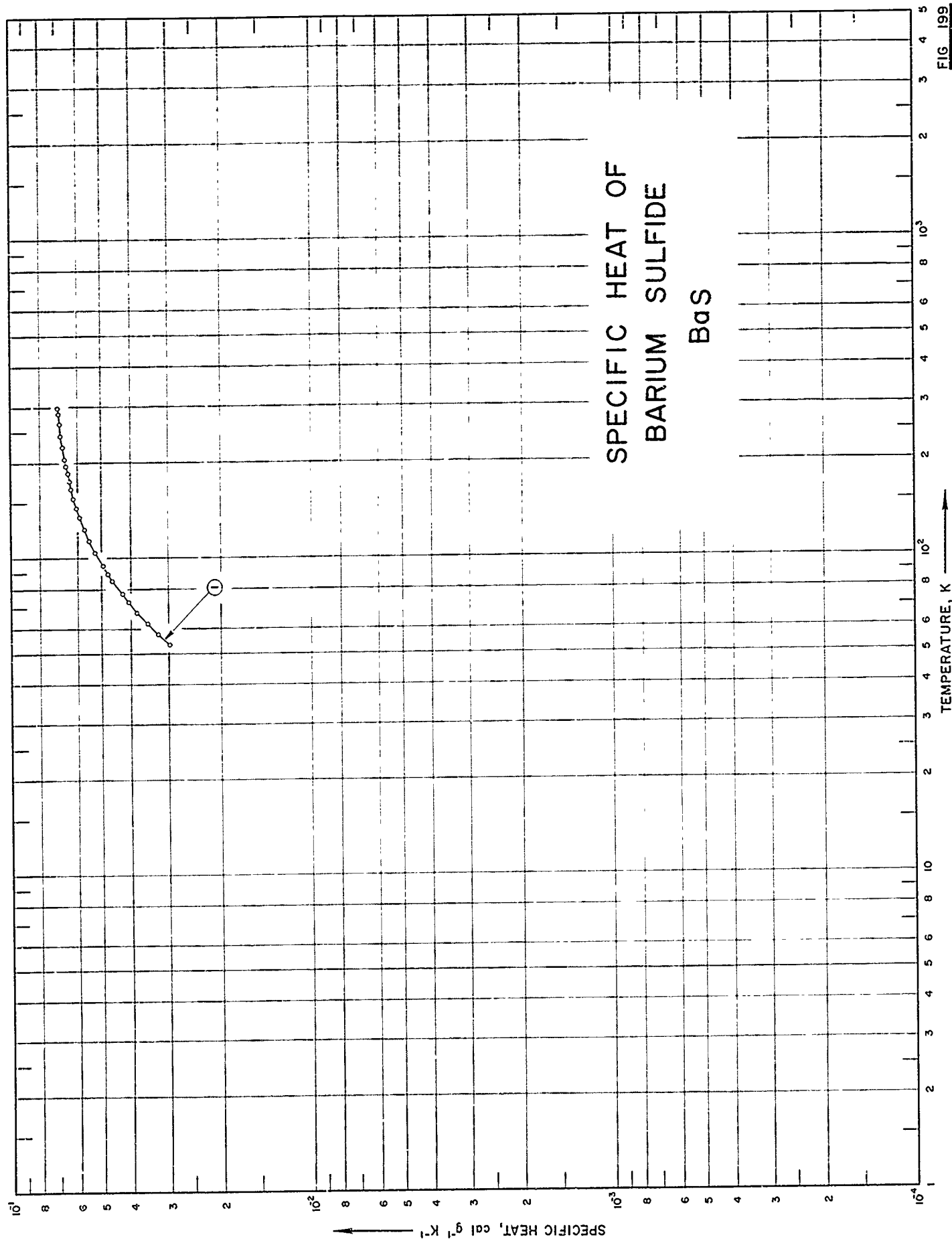

FIG. 199

SPECIFICATION TABLE NO. 199 SPECIFIC HEAT OF BARIUM SULFIDE BaS

[For Data Reported in Figure and Table No. 199]

Curve No.	Ref. No.	Year	Temp. Range, K	Reported Error, %	Name and Specimen Designation	Composition (weight percent), Specifications and Remarks
1	305	1960	54-298			99.53 BaS, 0.22 BaSO ₄ , 0.04 SiO ₂ ; prepared from reagent grade barium sulfate; ignited at 850 C and reduced by hydrogen at 1000 C.

DATA TABLE NO. 199 SPECIFIC HEAT OF BARIUM SULFIDE BaS
 [Temperature, T, K; Specific Heat, Cp, Cal g⁻¹K⁻¹]

T	Cp
53.71	2.989 x 10 ²
57.93	3.252
62.63	3.533
67.78	3.833
73.04	4.093
77.26	4.283
85.15	4.610
89.44	4.776
95.01	4.966
105.00	5.268
114.51	5.501
124.78	5.718
135.91	5.914
145.70	6.079
155.68	6.203
166.17	6.310
176.30	6.398
186.40	6.481
196.60	6.540
206.51	6.622
216.59	6.675*
226.26	6.723
236.07	6.764*
245.99	6.811
256.55	6.847*
266.90	6.876
276.56	6.912*
286.71	6.935
296.15	6.965*
298.15	6.965

* Not shown on plot

FIG. 200

SPECIFIC HEAT OF
DIBISMUTH TRISULFIDE
 Bi_2S_3

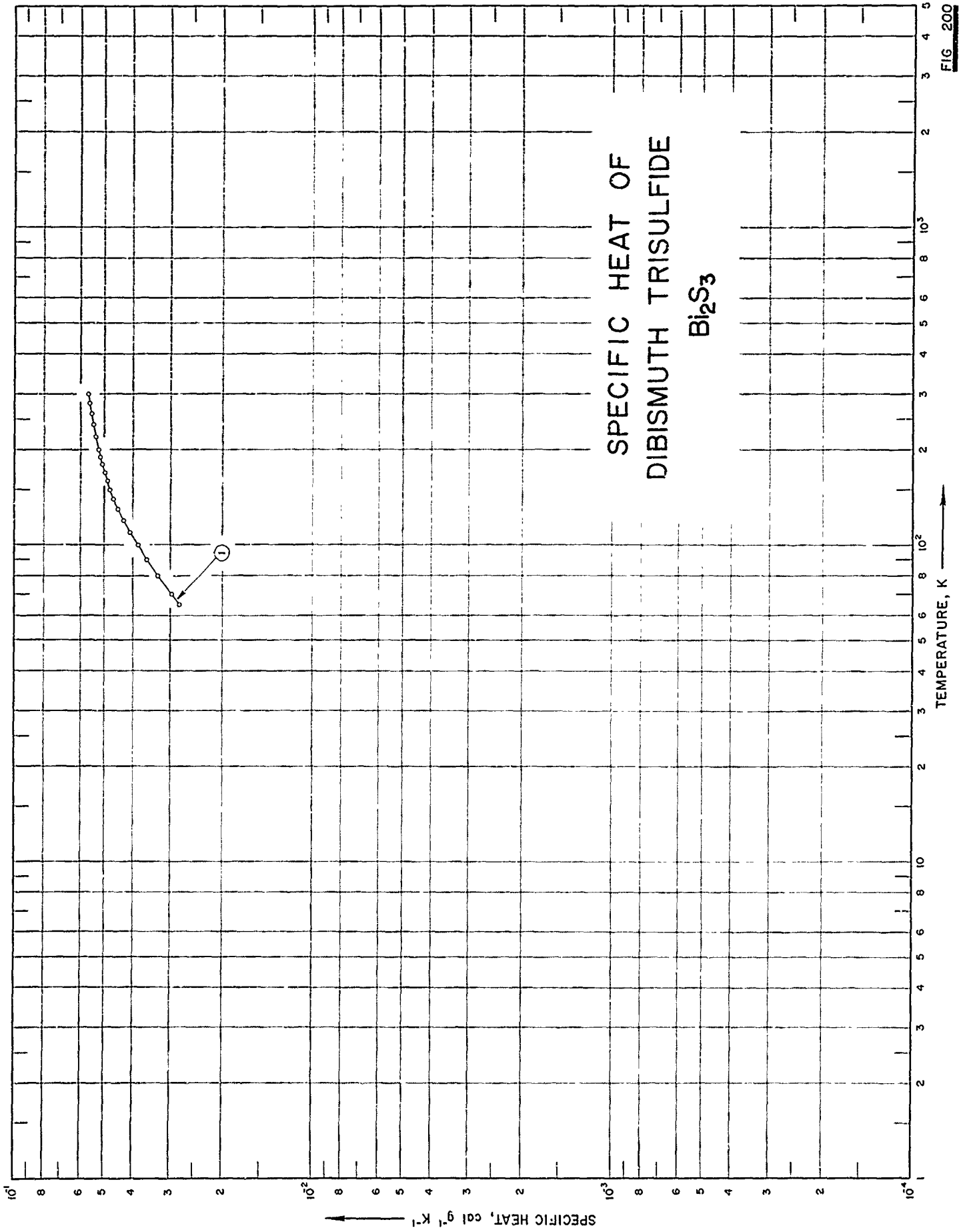

SPECIFICATION TABLE NO. 200 SPECIFIC HEAT OF DIBISMUTH TRISULFIDE Bi_2S_3

[For Data Reported in Figure and Table No. 200]

Curve No.	Ref. No.	Year	Temp. Range, K	Reported Error, %	Name and Specimen Designation	Composition (weight percent), Specifications and Remarks
1	28	1960	65-300			

DATA TABLE NO. 200 SPECIFIC HEAT OF DIBISMUTH TRISULFIDE Bi_2S_3
 [Temperature, T, K; Specific Heat, C_p , Cal $\text{g}^{-1}\text{K}^{-1}$]

T	C_p
	<u>CURVE 1</u>
65	2.80×10^2
70	2.97
80	3.31
90	3.60
100	3.86
110	4.10
120	4.31
130	4.49
140	4.67
150	4.79
160	4.89
170	4.99
180	5.08
190	5.16
200	5.23
210	5.28*
220	5.35
230	5.38*
240	5.44
250	5.46*
260	5.51
270	5.57*
280	5.61
290	5.64*
300	5.68

* Not shown on plot

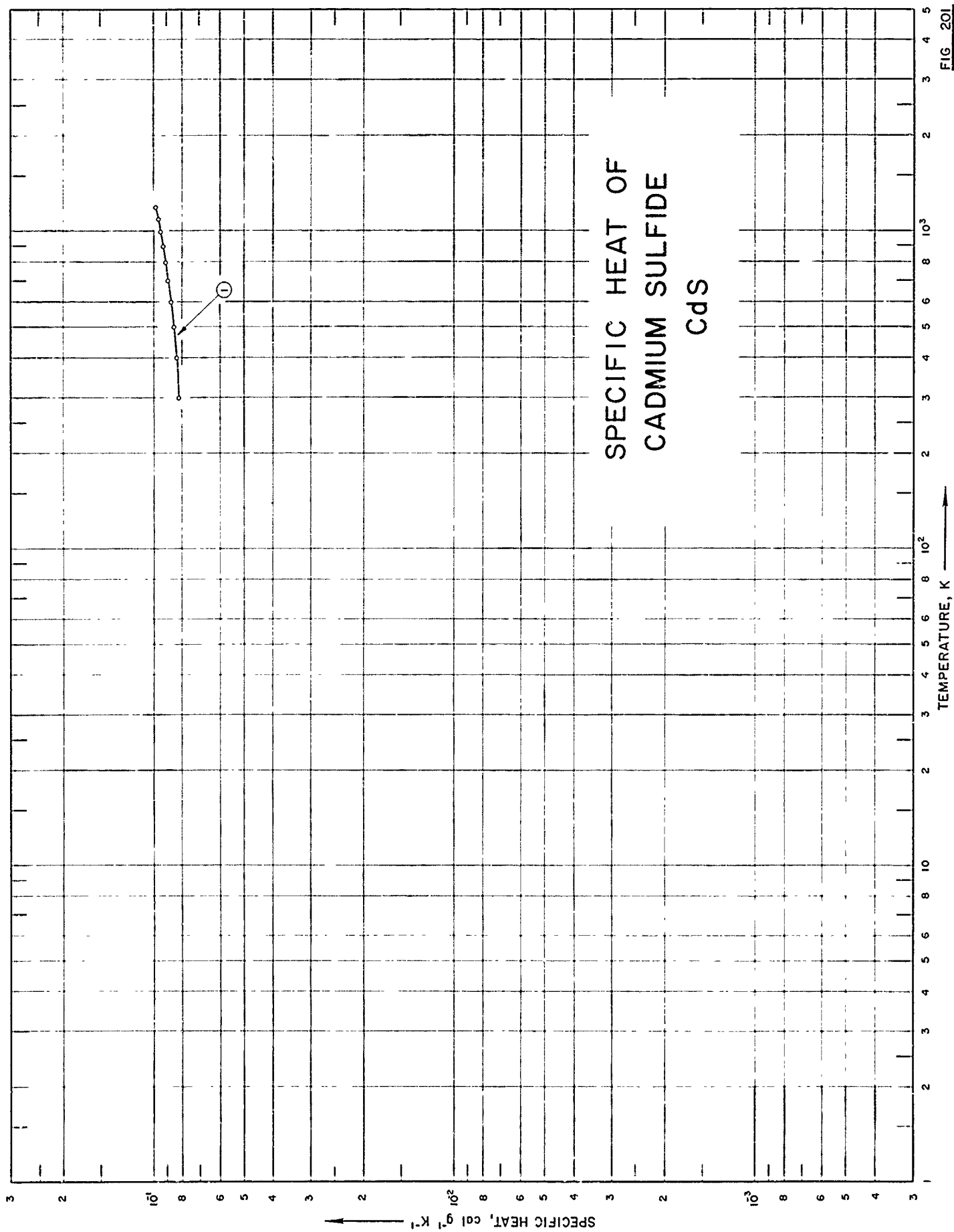

SPECIFIC HEAT OF
CADMIUM SULFIDE
CdS

FIG 201

SPECIFICATION TABLE NO. 201 SPECIFIC HEAT OF CADMIUM SULFIDE CdS

[For Data Reported in Figure and Table No. 201]

Curve No.	Ref. No.	Year	Temp. Range, K	Reported Error, %	Name and Specimen Designation	Composition (weight percent), Specifications and Remarks
1	54	1965	300-1200	1.5		~ 100 Cd S, 0.0005-0.0010 Si, and 0.00005 Mg; sample supplied by the Eagle-Picher Co.

DATA TABLE NO. 201 SPECIFIC HEAT OF CADMIUM SULFIDE Cds

[Temperature, T, K; Specific Heat, Cp, Cal g⁻¹K⁻¹]

T	Cp
<u>CURVE 1</u>	
300	8.210 x 10 ²
400	8.397
500	8.577
600	8.763
700	8.943
800	9.130
900	9.310
1000	9.497
1100	9.677
1200	9.864

* Not shown on plot.

FIG. 202

SPECIFIC HEAT OF CALCIUM SULFIDE CaS

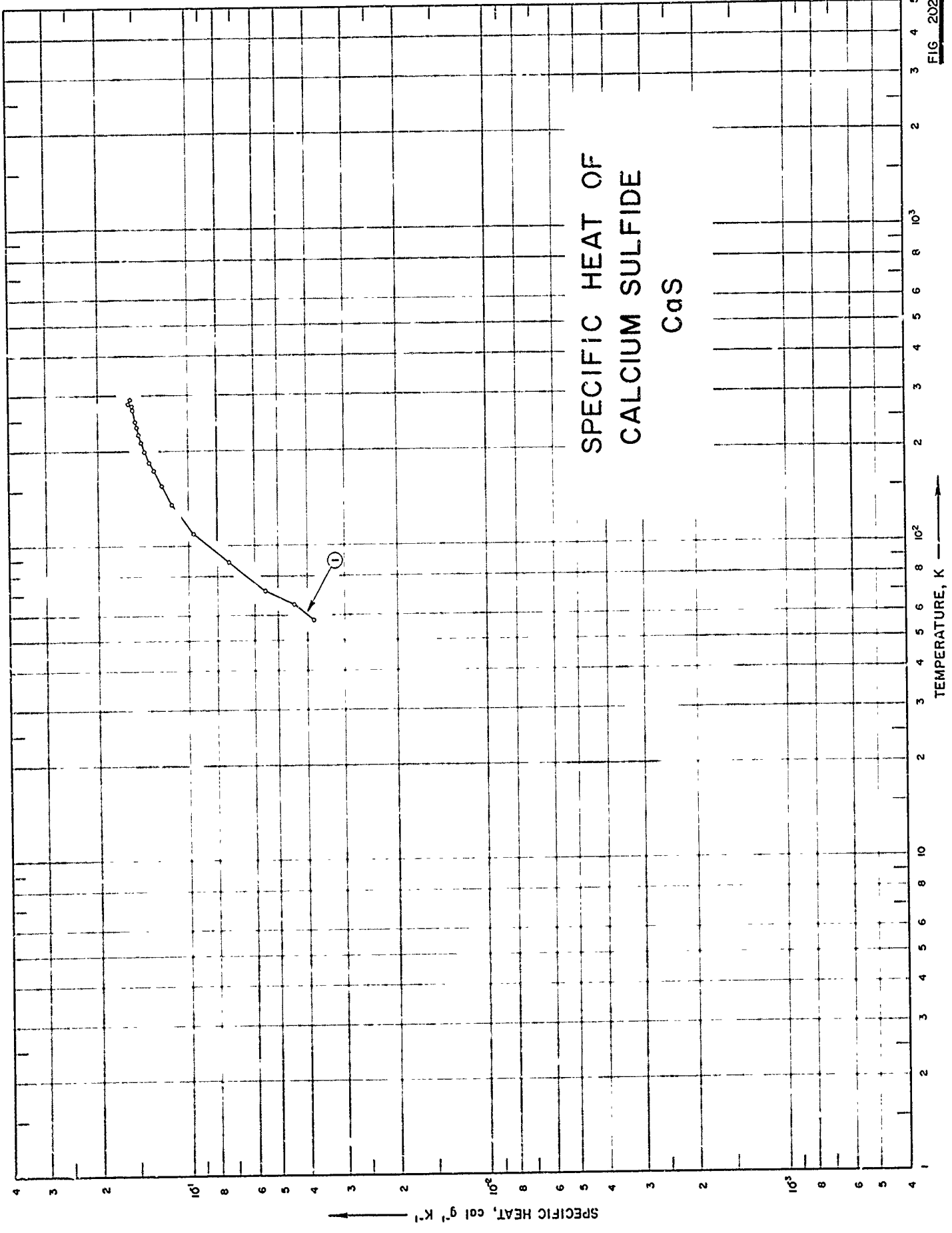

TEMPERATURE, K

SPECIFIC HEAT, cal g⁻¹ K⁻¹

SPECIFICATION TABLE NO. 20? SPECIFIC HEAT OF CALCIUM SULFIDE CaS

[For Data Reported in Figure and Table No. 202]

Curve No.	Ref. No.	Year	Temp. Range, K	Reported Error, %	Name and Specimen Designation	Composition (weight percent), Specifications and Remarks
1	340	1931	58-295			Prepared from calcium sulfate; density = 2.56 g cm ⁻³ at 23.6 C.

DATA TABLE NO. 202 SPECIFIC HEAT OF CALCIUM SULFIDE CaS
 [Temperature, T, K; Specific Heat, C_p , Cal $g^{-1}K^{-1}$]

T	C_p
<u>CURVE 1</u>	
58.1	3.843×10^{-2}
65.1	4.471
72.0	5.569
89.5	7.358
110.8	9.683
136.4	1.140×10^{-1}
155.9	1.233
174.7	1.306
185.3	1.358
200.5	1.406
214.6	1.445
226.9	1.464
239.4	1.485
249.6	1.507
271.2	1.538
279.5	1.547
285.5	1.592
290.1	1.564*
294.9	1.569

* Not shown on plot

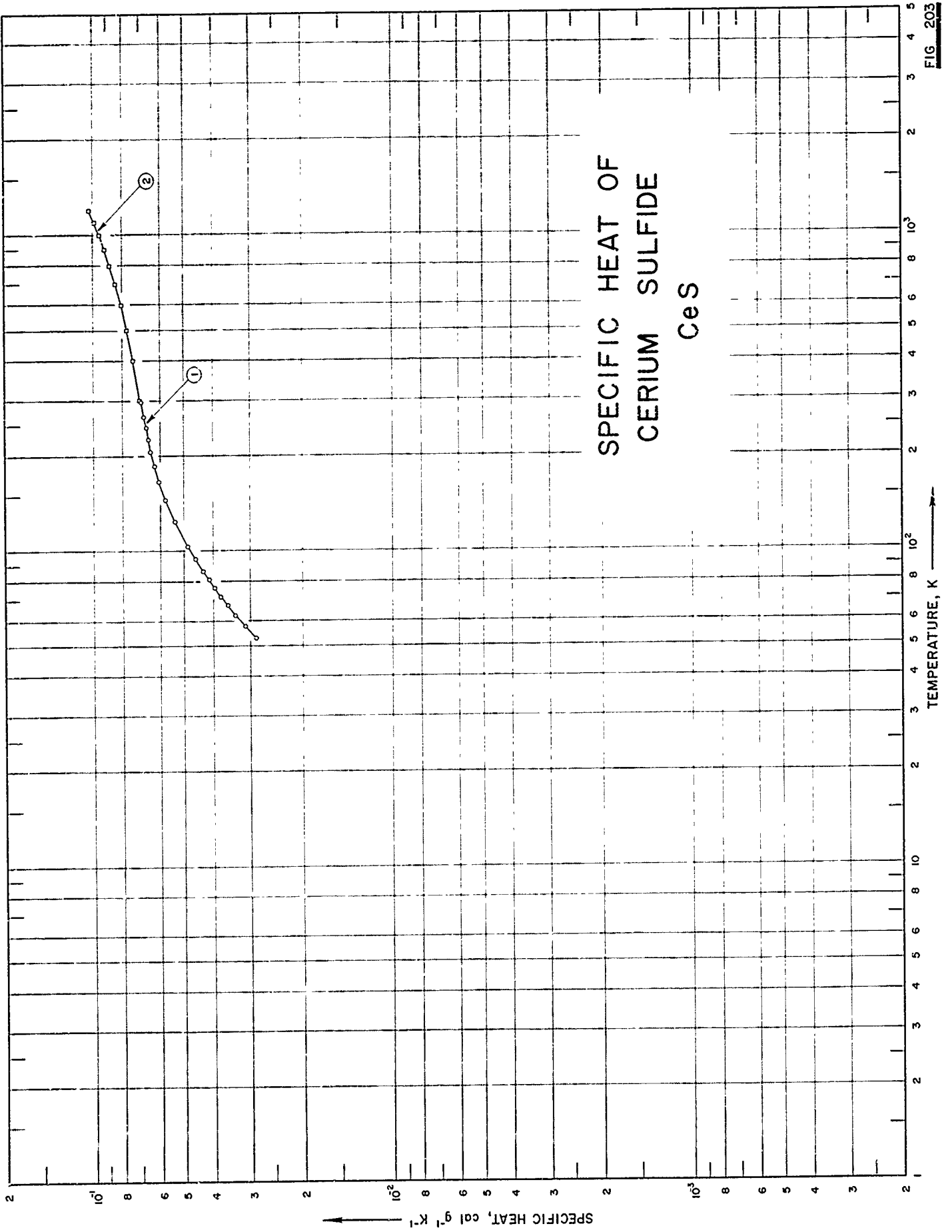

FIG. 203

SPECIFICATION TABLE NO. 203 SPECIFIC HEAT OF CERUM SULFIDE CeS

[For Data Reported in Figure and Table No. 203]

Curve No.	Ref. No.	Year	Temp. Range, K	Reported Error, %	Name and Specimen Designation	Composition (weight percent), Specifications and Remarks
1	306	1959	53-297	0.3		81.40 Ce (81.38 theo). 18.56 S (18.62 theo).
2	54	1965	300-1200	3.4		~100 CeS; traces of Cd and Mg.

DATA TABLE NO. 203 SPECIFIC HEAT OF CERIUM SULFIDE CeS

T, K; Specific Heat, Cp, Cal g⁻¹K⁻¹

T	Cp
<u>CURVE 1</u>	
53.13	2.879 x 10 ⁻²
57.88	3.128
62.88	3.369
67.44	3.576
71.97	3.771
76.67	3.958
81.60	4.134
86.30	4.301
94.53	4.572
104.82	4.882
114.66	5.126 ^a
124.84	5.362
135.94	5.587 ^a
145.86	5.762
156.19	5.923 ^a
166.24	6.051
176.18	6.162 ^a
186.33	6.266
196.35	6.353 ^a
206.50	6.440
216.40	6.510 ^a
226.37	6.580
236.26	6.638 ^a
245.98	6.696
256.30	6.748 ^a
266.30	6.800
276.39	6.835 ^a
286.65	6.882 ^a
296.72	6.934

T	Cp
<u>CURVE 2</u>	
300	6.987 x 10 ⁻²
400	7.347
500	7.713
600	8.073
700	8.439
800	8.805
900	9.165
1000	9.531
1100	9.891
1200	1.026 x 10 ⁻¹

^a Not shown on plot

SPECIFIC HEAT OF
DICERMIUM TRISULFIDE
 Ce_2S_3

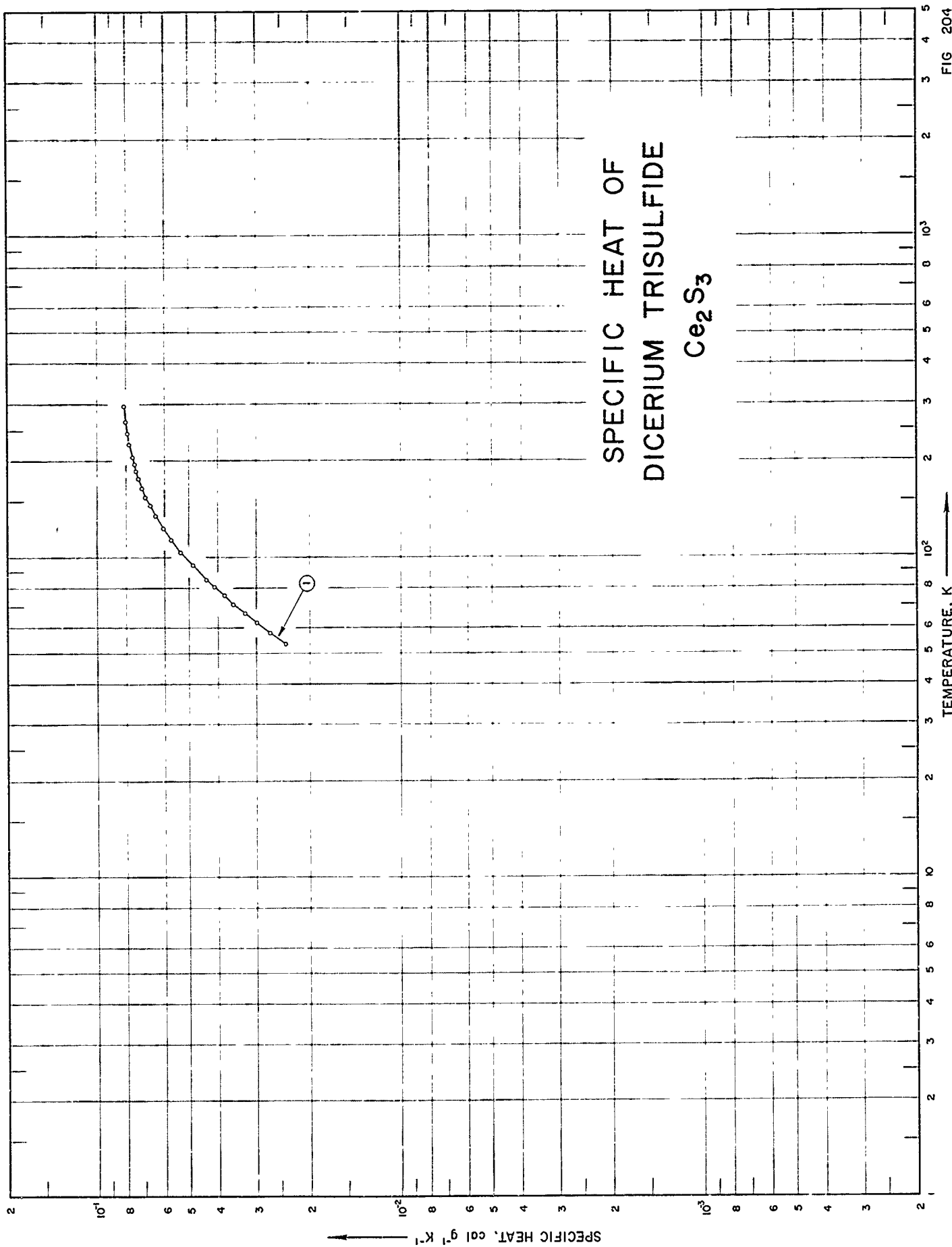

SPECIFICATION TABLE NO. 204 SPECIFIC HEAT OF DICERMIUM TRISULFIDE Ce_2S_7

[For Data Reported in Figure and Table No. 204]

Curve No.	Ref. No.	Year	Temp. Range, K	Reported Error, %	Name and Specimen Designation	Composition (weight percent), Specifications and Remarks
1	306	1959	54-296	0.3		74.27 Ce (74.45 theo) and 25.3 S (25.55 theo).

DATA TABLE NO. 204 SPECIFIC HEAT OF DICERURIUM TRISULFIDE Co_2S_3 [Temperature, T, K; Specific Heat, C_p , Cal $\text{g}^{-1}\text{K}^{-1}$]

T	C_p
53.63	2.402×10^{-2}
58.23	2.701
62.72	2.906
67.16	3.294
71.52	3.565
76.07	3.838
81.34	4.141
85.92	4.396
91.88	4.864
104.97	5.345
114.63	5.735
124.65	6.094
135.80	6.442
145.55	6.710
155.87	6.938
165.81	7.124
177.62	7.326
186.21	7.443
196.05	7.547
206.50	7.666
216.37	7.749*
226.30	7.844
236.44	7.903*
245.95	7.950
256.43	8.017*
266.29	8.049
276.31	8.091**
286.55	8.128*
296.11	8.174

* Not shown on plot

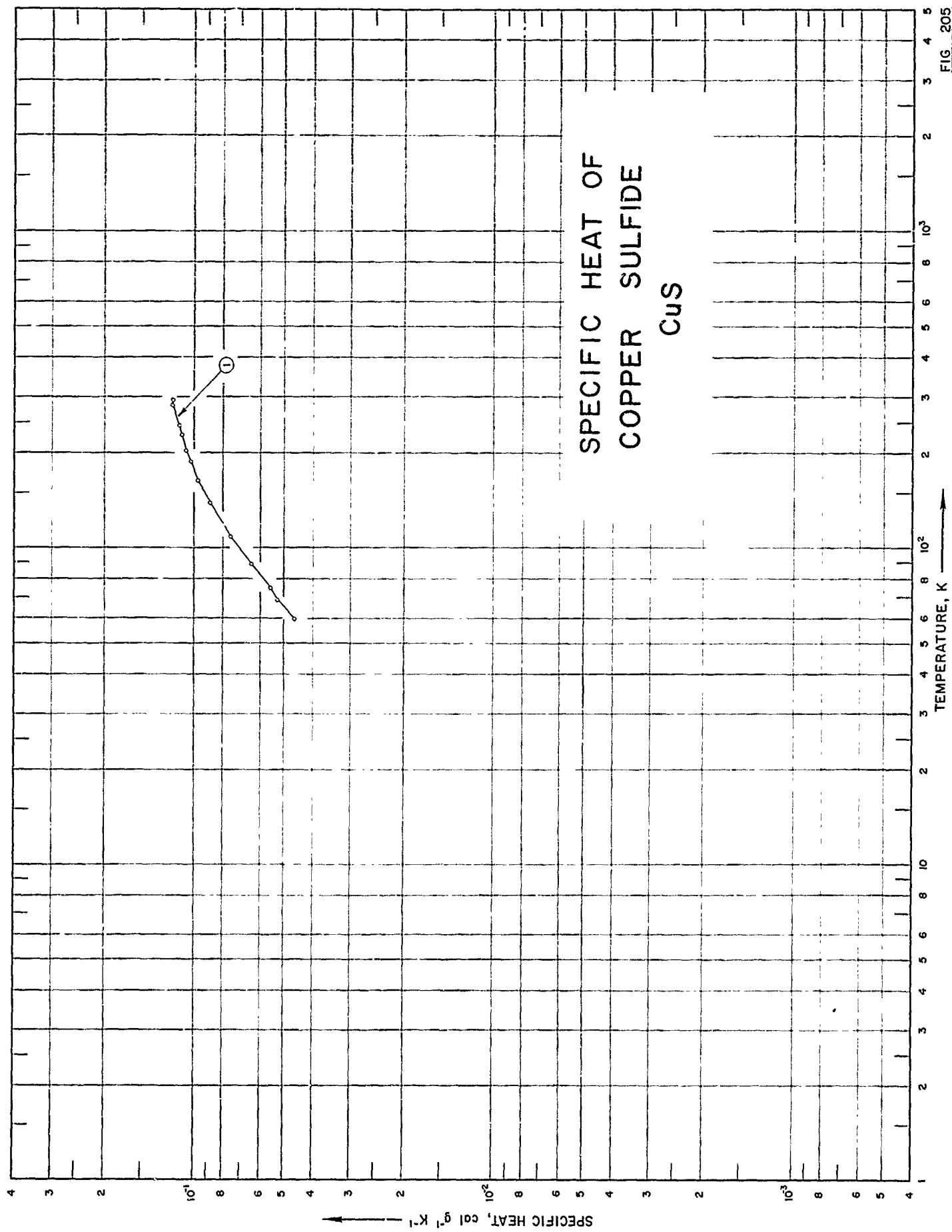

FIG. 205

SPECIFICATION TABLE NO. 205 SPECIFIC HEAT OF COPPER SULFIDE CuS

[For Data Reported in Figure and Table No. 205]

Curve No.	Ref. No.	Year	Temp. Range, K	Reported Error, %	Name and Specimen Designation	Composition (weight percent), Specifications and Remarks
1	341	1932	60-295		Covellite	Pure; natural mineral; density = 4.64 g cm^{-3} at 21.2 C .

DATA TABLE NO. 205 SPECIFIC HEAT OF COPPER SULFIDE CuS
 [Temperature, T, K; Specific Heat, Cp, Cal g⁻¹K⁻¹]

T	Cp
CURVE 1	
59.8	4.615 x 10 ⁻²
61.9	4.756*
68.6	5.271
75.1	5.588
89.0	6.461
109.9	7.572
139.0	8.898
164.4	9.703
177.6	1.006 x 10 ⁻⁴ *
188.0	1.027
203.2	1.062
215.4	1.086*
229.7	1.104
245.4	1.130
284.1	1.189
289.9	1.161*
294.6	1.186

* Not shown on plot

FIG 206

SPECIFIC HEAT OF
DICOPPER SULFIDE
 Cu_2S

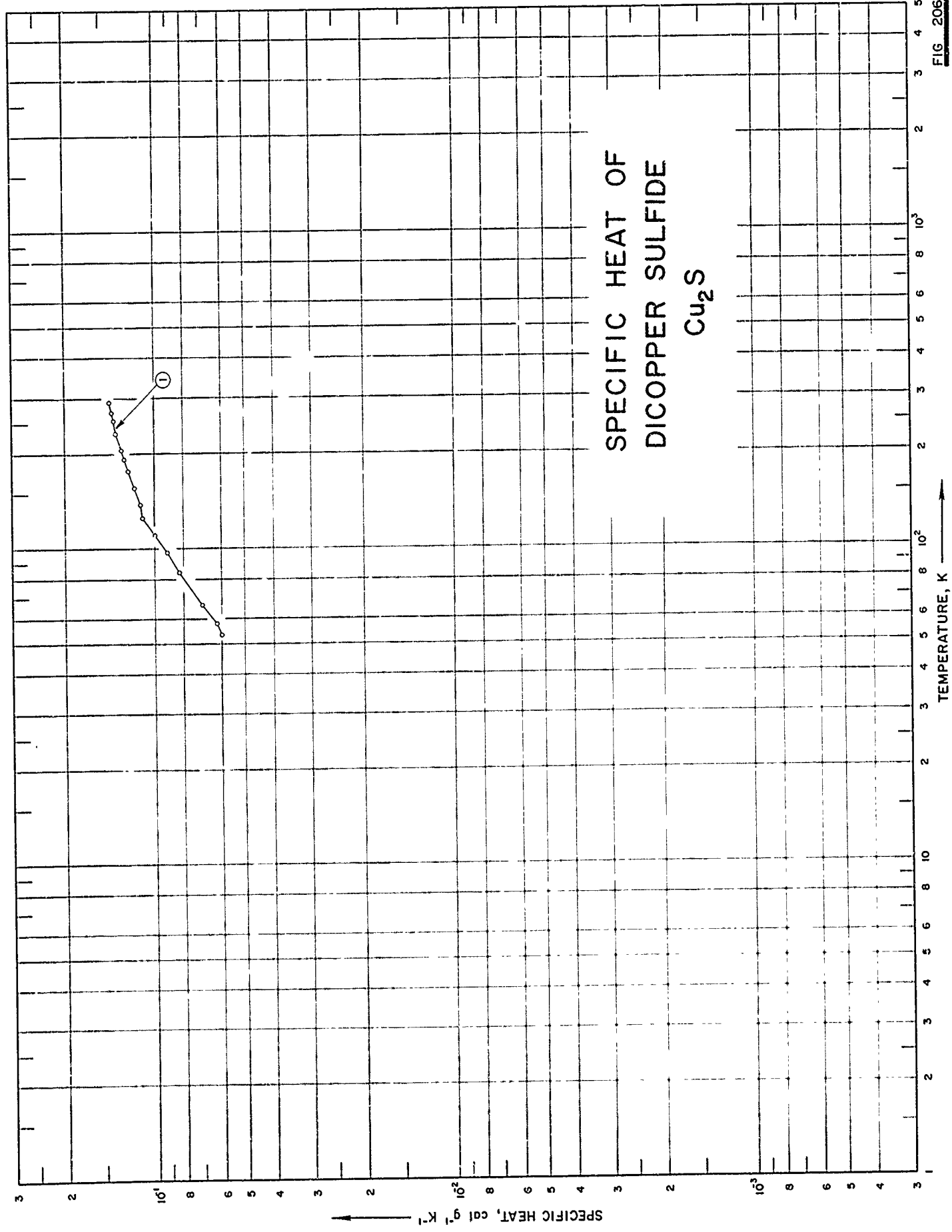

SPECIFICATION TABLE NO. 206 SPECIFIC HEAT OF DICOPPER SULFIDE Cu_2S

[For Data Reported in Figure and Table No. 206]

Curve No.	Ref. No.	Year	Temp. Range, K	Reported Error, %	Name and Specimen Designation	Composition (weight percent), Specifications and Remarks
1	341	1932	54-292			99.8 Cu_2S ; crystalline; density = 5.76 g cm^{-3} at 22.4 C .

DATA TABLE NO. 206 SPECIFIC HEAT OF DICOPPER SULFIDE Cu_2S
 Temperature, T, K; Specific Heat, C_p , Cal $\text{g}^{-1}\text{K}^{-1}$

T	C_p
	<u>CURVE 1</u>
53.7	6.010×10^2
56.1	6.012
58.0	6.256
62.6	6.709
66.1	6.994
71.3	7.459
84.4	8.364
97.6	9.171
111.6	1.011×10^{-1}
126.0	1.100
139.0	1.122
157.0	1.174
177.2	1.237
193.3	1.263
206.8	1.299
210.4	1.306
232.5	1.352
243.9	1.362
255.6	1.375
271.4	1.399
285.4	1.416
292.2	1.424

* Not shown on plot

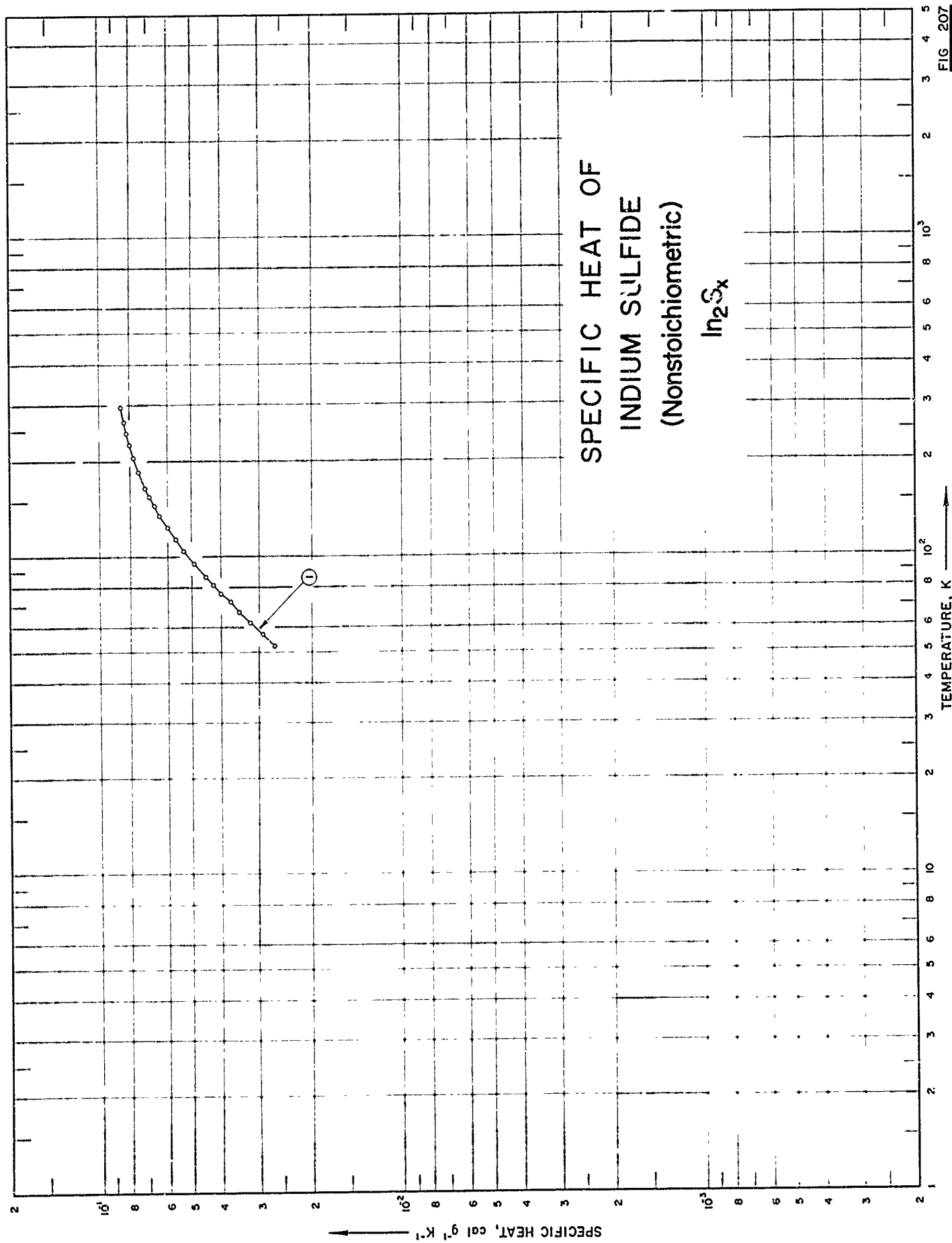

SPECIFICATION TABLE NO. 207 SPECIFIC HEAT OF DIINDIUM SULFIDE (nonstoichiometric) In_2S_x

[For Data Reported in Figure and Table No. 207]

Curve No.	Ref. No.	Year	Temp. Range, K	Reported Error, %	Name and Specimen Designation	Composition (weight percent), Specifications and Remarks
1	338	1962	53-297			$\text{In}_2\text{S}_{2.33}$; 70.49 In, 28.84 S, 0.56 H_2O and 0.1 SiO_2 ; data corrected for impurities.

DATA TABLE NO. 207 SPECIFIC HEAT OF DIINDIUM SULFIDE In_2S_x (nonstoichiometric)
 [Temperature, T, K; Specific Heat, C_p , Cal $\text{g}^{-1}\text{K}^{-1}$]

T	C_p
CURVE 1	
52.66	2.66×10^{-2}
57.26	2.92
62.39	3.208
67.32	3.492
72.02	3.739
76.70	4.002
81.74	4.243
86.42	4.496
95.14	4.904
104.85	5.322
114.28	5.683
124.64	6.051
135.81	6.409
145.69	6.687
156.10	6.929
165.88	7.145
175.99	7.340*
185.91	7.519
196.08	7.664*
206.23	7.800
216.07	7.917*
226.16	8.038
236.05	8.140*
245.88	8.217
256.48	8.310*
266.42	8.393
277.33	8.449*
286.84	8.526*
296.75	8.600

* Not shown on plot

FIG. 208

SPECIFIC HEAT OF
IRON SULFIDE
(Nonstoichiometric)
 Fe_xS

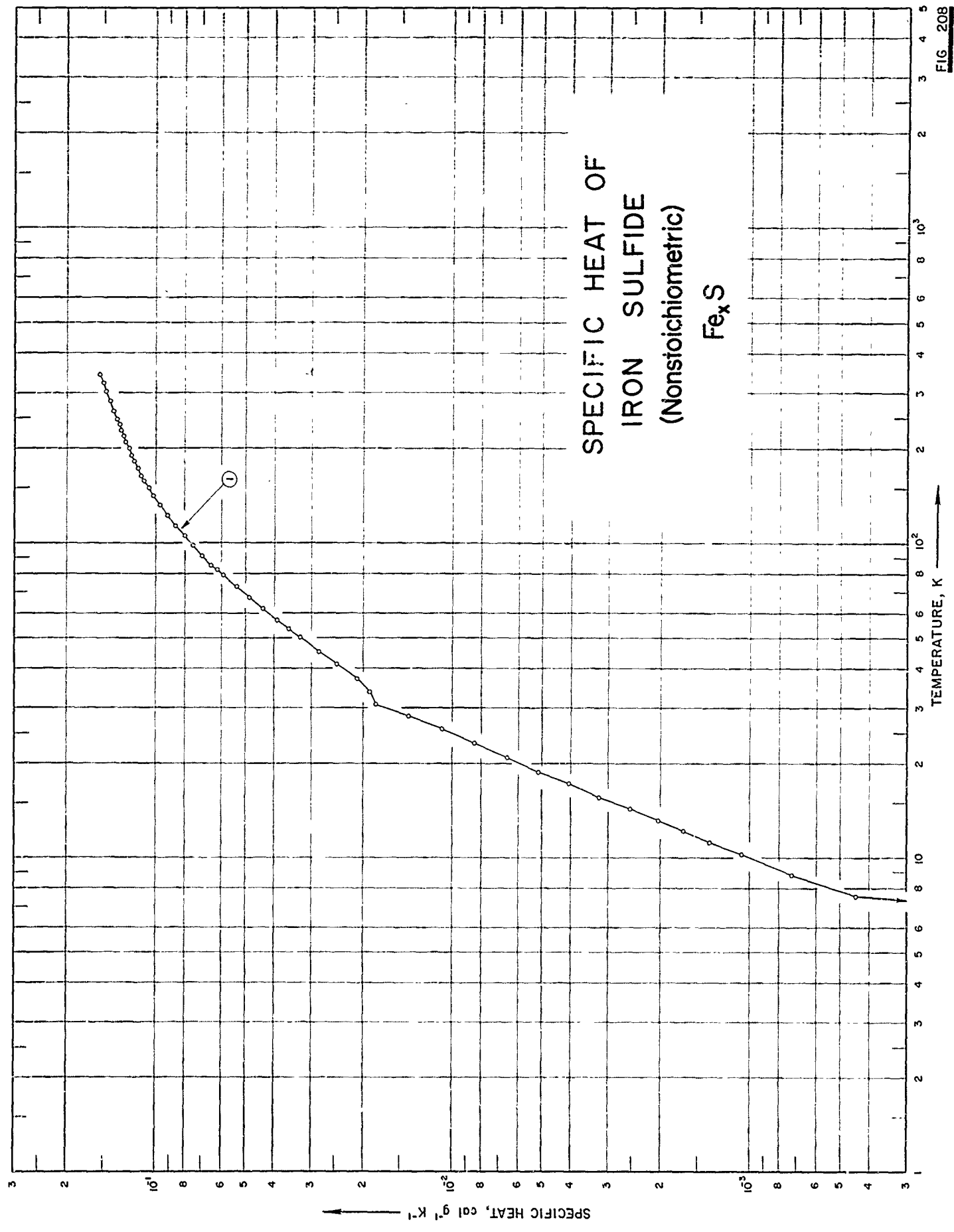

SPECIFICATION TABLE NO. 208 SPECIFIC HEAT OF IRON SULFIDE (nonstoichiometric) Fe_xS

[For Data Reported in Figure and Table No. 208]

Curve No.	Ref. No.	Year	Temp. Range, K	Reported Error, %	Name and Specimen Designation	Composition (weight percent), Specifications and Remarks
1	307	1959	6-347	0.1	sulfur-rich pyrrhotite	$Fe_{0.87}S$; iron impurities, ~ 0.01 Ni, S and ~ 0.001 Mn, sulfur purified by double distillation; prepared by reacting stoichiometric amounts of iron and sulfur in electric furnace at 800 C; after reaction has gone almost to completion, it was cooled; heated at 800 C for 7 days; cooled to 100 C per day to room temperature; fragmented; homogenized at 290 C and after 30 days cooled to room temperature over a period of 6 days.

DATA TABLE NO. 208 SPECIFIC HEAT OF IRON SULFIDE Fe_xS (nonstoichiometric)
 [Temperature, T, K; Specific Heat, C_p , Cal $\text{g}^{-1}\text{K}^{-1}$]

T	C_p	T	C_p	T	C_p
CURVE I (cont.) Series I		CURVE I (cont.) Series V		CURVE I (cont.) Series VI	
82.50	6.233×10^{-2}	272.68	1.421×10^{-1k}	5.82	2.714×10^{-5k}
85.92	6.535	282.83	1.441	6.52	9.254^*
91.76	7.015	293.09	1.462^*	7.20	2.394×10^{-4k}
98.77	7.537	303.38	1.481	8.48	7.020^*
106.21	8.076	313.63	1.499^*	Series VI	
114.28	8.619	323.84	1.518	5.97	3.578×10^{-5k}
123.44	9.199	334.05	1.536^*	6.36	7.279^*
132.83	9.736	344.27	1.553	7.88	6.391×10^{-4k}
141.63	1.020×10^{-1}	Series III		10.17	1.055×10^{-3k}
150.19	1.061	246.87	1.366×10^{-1k}	Series VII*	
158.69	1.100	256.33	1.387*	6.07	4.318×10^{-5}
164.39	1.123	266.32	1.408*	7.90	6.305×10^{-4}
173.39	1.156	276.40	1.430^*	7.92	6.428
182.49	1.190	286.51	1.448*	9.79	9.377
190.68	1.219	296.68	1.468^*	29.06	1.498×10^{-2}
200.89	1.247	306.86	1.487*	39.57	1.783
210.12	1.275	317.01	1.506^*	32.21	1.843
219.45	1.298	327.12	1.524^*	33.97	1.900
228.87	1.323	337.27	1.542^*	35.87	1.999
238.50	1.346	347.48	1.561*	Series IV	
248.25	1.368	Series II		Series V	
53.65	3.599×10^{-2}	7.55	4.405×10^{-4}	Series VI	
57.16	3.921	8.88	7.255	Series VII	
62.08	4.390	10.21	1.073×10^{-3}	Series VIII	
67.34	4.881	11.22	1.376	Series IX	
73.04	5.390	12.18	1.687	Series X	
79.29	5.953	13.16	2.044	Series XI	
86.06	6.548^*	14.30	2.534	Series XII	
93.74	7.160^*	15.67	3.213	Series XIII	
101.84	7.764^*	17.23	4.081	Series XIV	
108.69	8.250^*	18.76	5.181	Series XV	
117.20	8.811^*	20.90	6.579	Series XVI	
126.00	9.357^*	23.19	8.453	Series XVII	
134.89	9.848^*	25.72	1.088×10^{-2}	Series XVIII	
149.76	1.060×10^{-2}	28.34	1.402	Series XIX	
169.95	1.145^*	36.88	1.825	Series XX	
194.10	1.228^*	33.70	1.904	Series XXI	
223.47	1.309*	37.26	2.104	Series XXII	
240.61	1.351^*	41.41	2.459	Series XXIII	
252.46	1.378^*	45.69	2.848	Series XXIV	
262.52	1.400	50.18	3.268	Series XXV	
		55.22	3.738*	Series XXVI	
		60.62	4.248*	Series XXVII	

* Not shown on plot

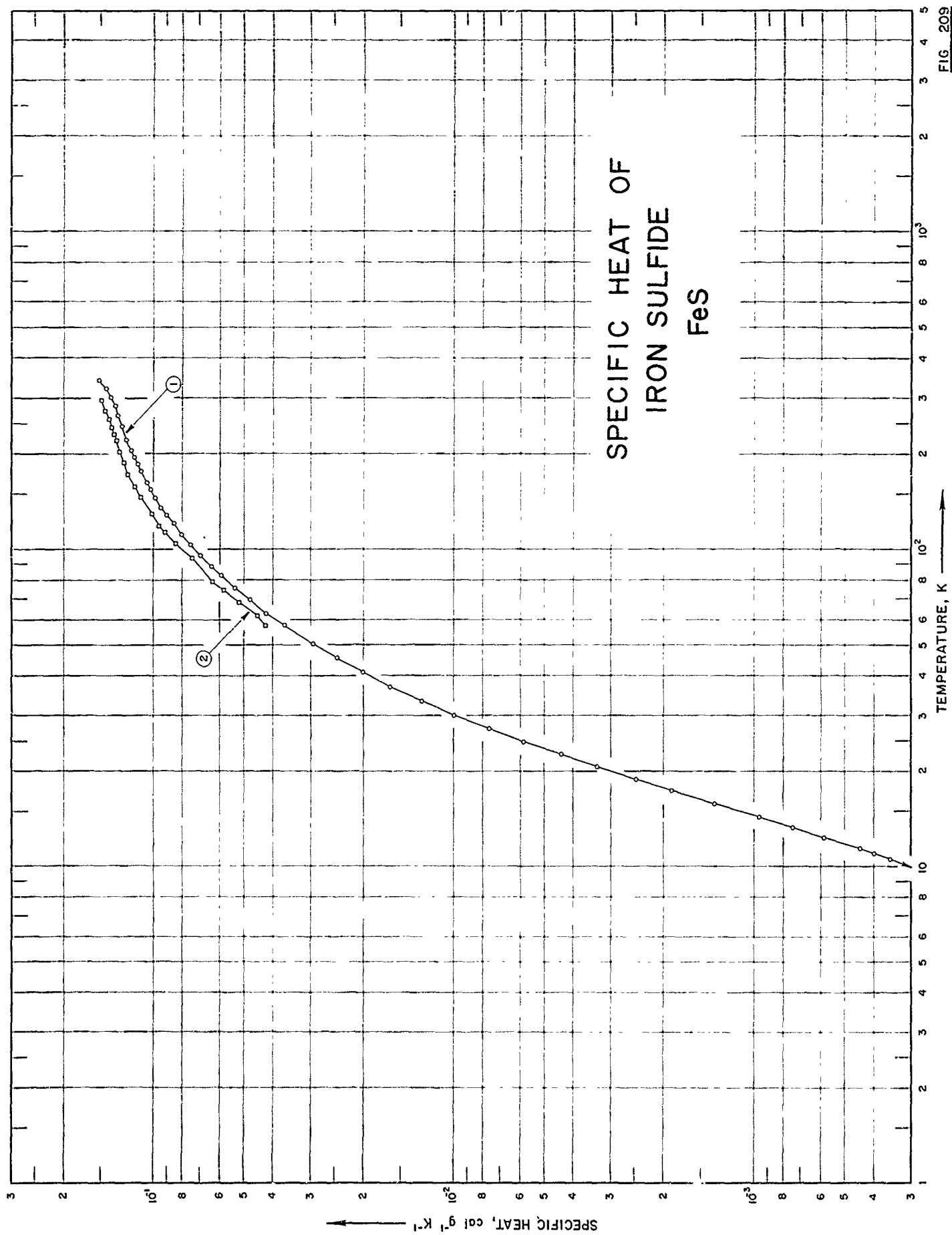

FIG. 209

SPECIFICATION TABLE NO. 209 SPECIFIC HEAT OF IRON SULFIDE FeS

[For Data Reported in Figure and Table No. 209]

Curve No.	Ref. No	Year	Temp. Range, K	Reported Error, %	Name and Specimen Designation	Composition (weight percent), Specifications and Remarks
1	307	1959	7-345	0.1	Iron-rich pyrrhotite	<p>Iron impurities: ~0.01 Ni, S, and ~0.001 Mn, sulfur purified by double distillation; prepared by reacting Fe and S in electric furnace at 800 C; after reaction has gone almost to completion it was cooled heated at 800 C for 7 days; cooled to 100 C per day to room temperature; fragmented; homogenized at 290 C and after 30 days cooled to room temperature over a period of 6 days.</p> <p>Prepared from mixture of iron oxides made from strips of pure ingot iron by heating in air several days at 900 C; density = 4.65 g cm³ at 23.9 C.</p>
2	340	1931	58-296			

DATA TABLE NO. 209 SPECIFIC HEAT OF IRON SULFIDE FeS

[Temperature, T, K; Specific Heat, C_p , Cal g⁻¹K⁻¹]

T	C_p	CURVE 1 (cont.)		T	C_p	CURVE 2 (cont.)	
		Series I	Series II			CURVE 1 (cont.)	CURVE 2 (cont.)
88.72	6.412 x 10 ⁻²			47.93	2.680 x 10 ⁻² *	159.0	1.166 x 10 ⁻¹
95.96	6.951			52.81	3.157*	173.1	1.222
104.18	7.527			58.03	3.666	188.2	1.259
112.76	8.090			63.80	4.224	204.6	1.301
121.00	8.593			69.89	4.779	221.2	1.340
129.31	9.061			76.19	5.341	231.6	1.356
137.68	9.476			83.16	5.952	244.6	1.373
146.16	9.868			90.82	6.572*	258.0	1.408
154.88	1.024 x 10 ⁻¹			159.12	1.040 x 10 ⁻¹ *	275.8	1.455
163.96	1.059			168.14	1.073*	296.0	1.493
				177.57	1.105		
				187.20	1.134		
				196.73	1.161		
				206.16	1.185		
				215.88	1.208*		
6.97	9.782 x 10 ⁻⁵ *			225.75	1.231		
8.32	1.820 x 10 ⁻⁴ *			235.53	1.252*		
9.05	2.252*			245.35	1.272		
9.86	2.969*			255.25	1.291*		
10.56	3.594			265.27	1.310		
11.42	4.459			275.34	1.330*		
12.39	5.892			285.33	1.349		
13.32	7.473			294.91	1.366*		
14.38	9.691			304.92	1.390		
15.84	1.366 x 10 ⁻³			314.90	1.416*		
17.42	1.882			324.74	1.442		
18.90	2.476			334.71	1.487*		
20.63	3.363			344.70	1.529		
22.63	4.403						
24.85	5.825						
27.29	7.623						
30.16	9.961						
33.46	1.283 x 10 ⁻²						
37.06	1.620			57.9	4.242 x 10 ⁻²		
41.11	2.009			60.1	4.344*		
45.71	2.457			62.0	4.509		
50.67	2.950			68.4	5.182		
				71.1	5.479*		
				74.5	5.823		
				79.4	6.328		
				93.7	7.408		
				105.7	8.432		
7.05	1.012 x 10 ⁻⁴ *			113.5	9.113		
7.80	1.285*			119.9	9.551		
8.48	1.805*			130.4	1.017 x 10 ⁻¹		
9.11	2.320*			146.4	1.104		
9.75	2.855*						

* Not shown on plot

SPECIFIC HEAT OF IRON DISULFIDE FeS₂

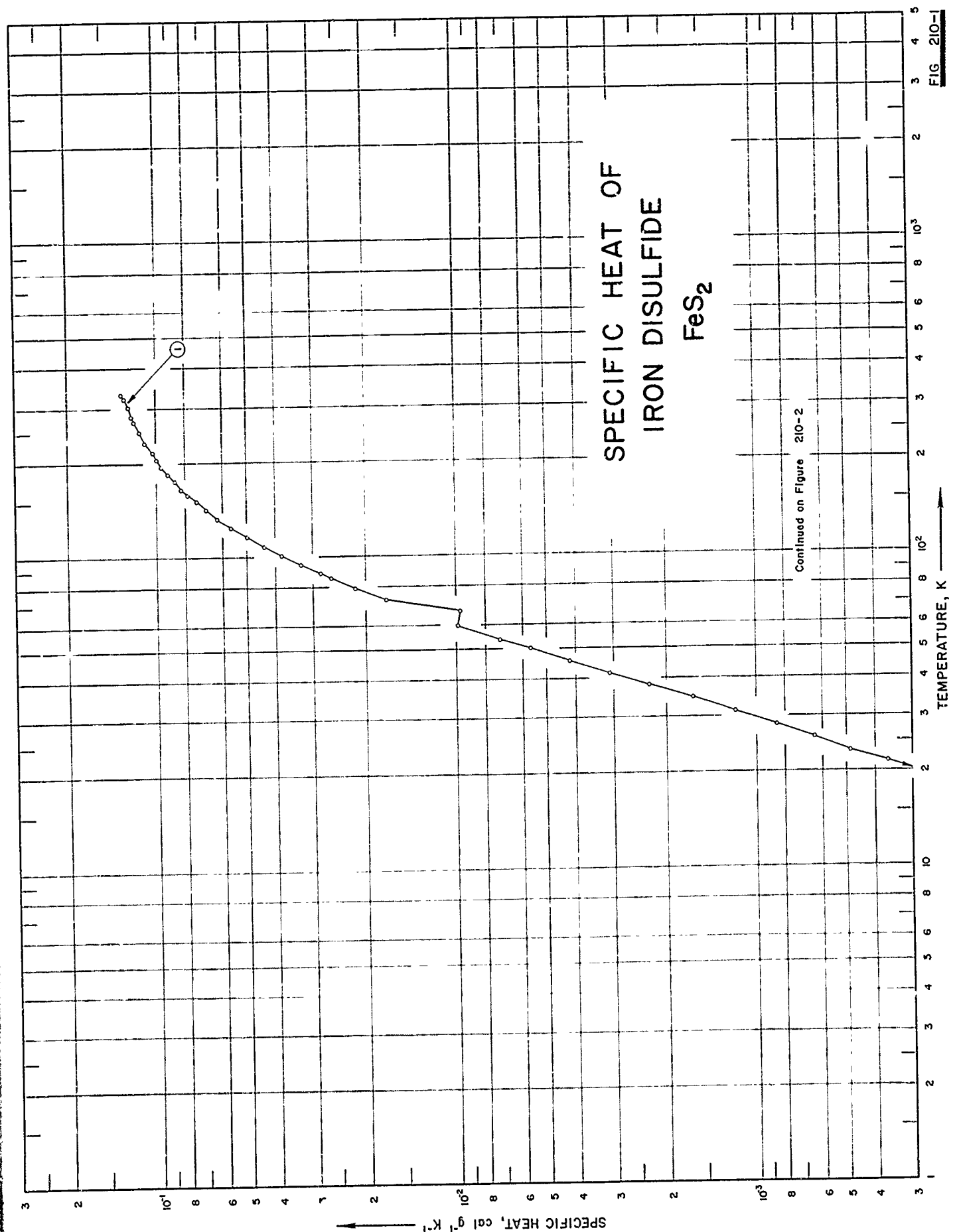

Continued on Figure 210-2

SPECIFIC HEAT, cal g⁻¹ K⁻¹

TEMPERATURE, K

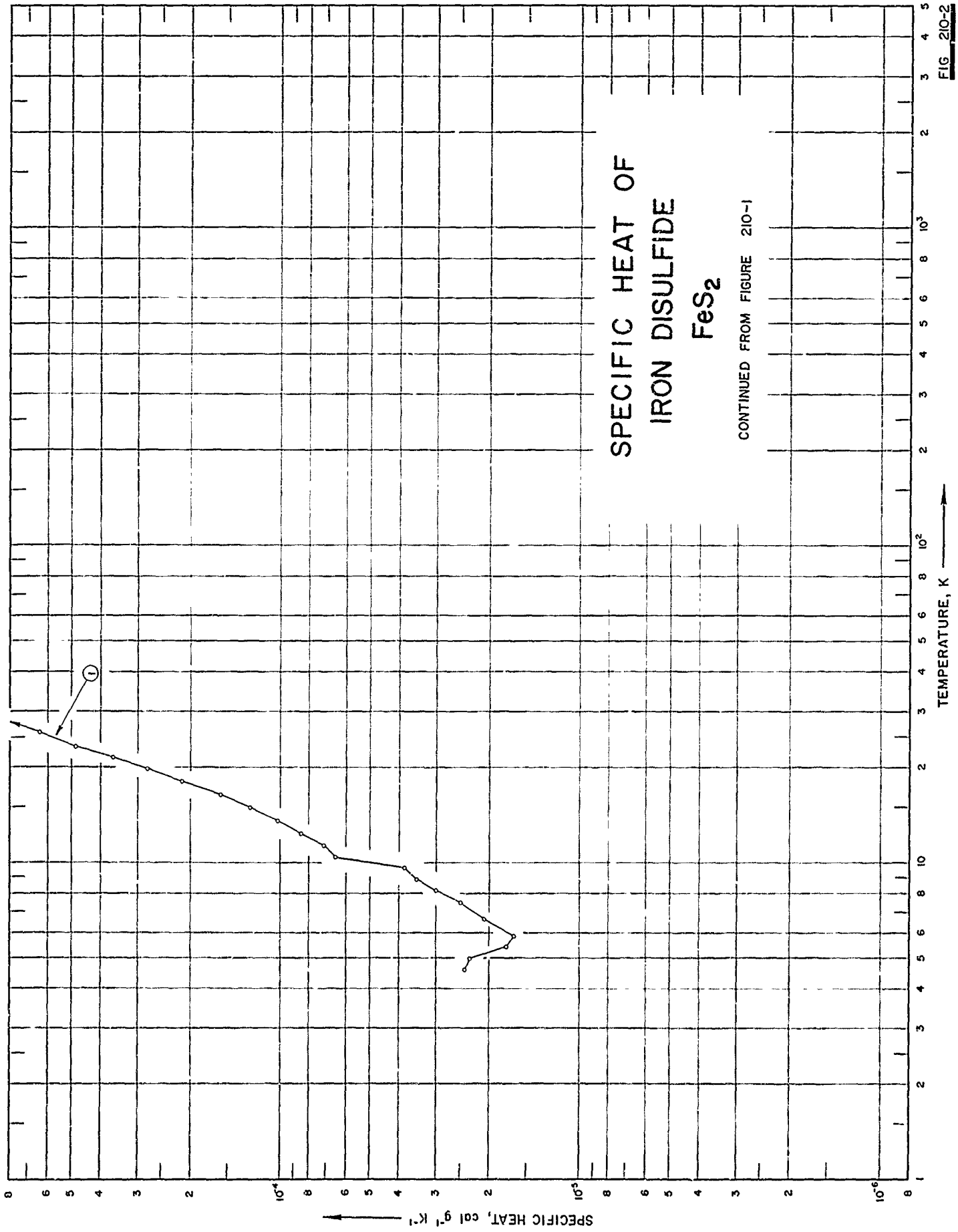

FIG 210-2

SPECIFICATION TABLE NO. 210 SPECIFIC HEAT OF IRON DISULFIDE FeS_2

[For Data Reported in Figure and Table No. 210]

Curve No.	Ref. No.	Year	Temp. Range, K	Reported Error, %	Name and Specimen Designation	Composition (weight percent), Specifications and Remarks
1	214	1962	5-346	0.1-5.0	Pyrite	53.45 ± 0.04 S, 46.53 ± 0.03 Fe, 0.008 each Mn, Si and 0.0075 Ni; sample supplied by Besmo grube, Nordland, Norway; crushed to 30-80 mesh powder.

DATA TABLE NO. 210 SPECIFIC HEAT OF IRON DISULFIDE FeS_2 [Temperature, T, K; Specific Heat, Cp, Cal $\text{g}^{-1}\text{K}^{-1}$]

T	Cp	T	Cp
CURVE I Series I		CURVE I (cont.)	
88.33	2.841×10^{-2}	72.30	1.704×10^{-2}
94.32	3.291	79.05	2.160
101.09	3.811	85.37	2.618
108.46	4.375	Series III	
116.55	4.993	165.68	8.296×10^{-2}
125.07	5.618	175.23	8.667
133.89	6.240	185.37	9.147
142.51	6.812	195.90	9.602
151.07	7.350	206.03	9.995
159.84	7.860	215.79	1.035×10^{-1}
Series II		225.20	1.066*
4.60	2.417×10^{-6}	234.29	1.092
5.06	2.334	243.43	1.118
5.43	1.750	252.56	1.142
5.89	1.667	261.95	1.166*
6.65	2.084	271.37	1.184
7.49	2.500	275.57	1.193*
8.16	3.001	284.53	1.214
8.87	3.501	293.71	1.230*
9.62	3.834	302.98	1.247
10.49	5.584	312.19	1.263
11.37	6.668	321.44	1.276
12.45	8.501	330.09	1.289*
13.65	1.017×10^{-4}	338.12	1.299*
14.98	1.267	346.11	1.306
16.46	1.584	Series III	
18.06	2.142	165.68	8.296×10^{-2}
19.77	2.792	175.23	8.667
21.56	3.642	185.37	9.147
23.56	4.842	195.90	9.602
25.78	6.376	206.03	9.995
28.28	8.501	215.79	1.035×10^{-1}
31.23	1.174×10^{-3}	225.20	1.066*
34.63	1.624	234.29	1.092
38.18	2.283	243.43	1.118
41.86	3.094	252.56	1.142
45.88	4.209	261.95	1.166*
50.15	5.644	271.37	1.184
53.99	7.180	275.57	1.193*
59.86	9.893	284.53	1.214
66.09	9.660	293.71	1.230*
		302.98	1.247
		312.19	1.263
		321.44	1.276
		330.09	1.289*
		338.12	1.299*
		346.11	1.306

* Not shown on plot

FIG 211

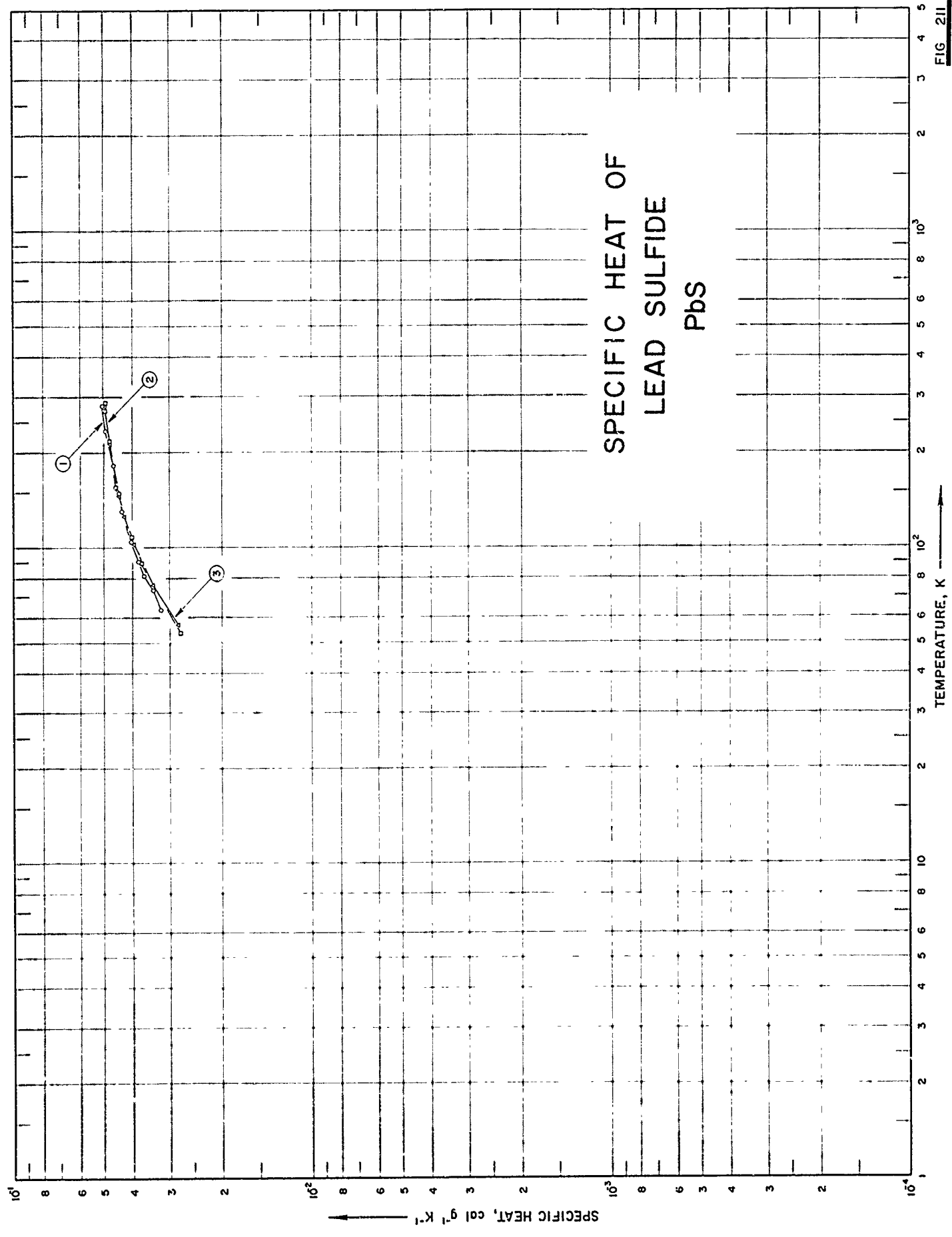

SPECIFICATION TABLE NO. 211 SPECIFIC HEAT OF LEAD SULFIDE PbS

[For Data Reported in Figure and Table No. 211]

Curve No.	Ref. No.	Year	Temp. Range, K	Reported Error, %	Name and Specimen Designation	Composition (weight percent), Specifications and Remarks
1	308	1918	64-283	< 1.0	Galena	
2	341	1932	54-289		Galena	Density = 7.57 g cm ⁻³ at 22.4 C.
3	341	1932	54-282		Synthetic lead sulfide	Prepared by the carbon dioxide disulfide method; density = 7.57 g cm ⁻³ at 22.4 C.

DATA TABLE NO. 211 SPECIFIC HEAT OF LEAD SULFIDE PbS

[Temperature, T, K; Specific Heat, Cp, Cal g⁻¹K⁻¹]

T	Cp	T	Cp
<u>CURVE 1</u>			
63.8	3.22 x 10 ²	138.2	4.393 x 10 ^{2*}
66.6	3.33*	156.5	4.522
70.0	3.38*	172.1	4.698*
73.1	3.49	201.9	4.748*
75.9	3.51*	218.3	4.798
78.8	3.61*	232.7	4.819*
81.7	3.68	247.5	4.828*
84.6	3.71*	271.3	4.915
87.4	3.79*	280.4	4.924*
90.1	3.81	282.6	4.907*
96.9	3.95*	289.4	4.911
100.0	4.01*	<u>CURVE 3</u>	
105.3	4.05	54.0	2.729 x 10 ^{-2*}
109.2	4.05*	57.3	2.826
111.8	4.11*	61.1	2.958*
114.3	4.13*	64.2	3.128*
121.9	4.17*	76.2	3.430
124.2	4.21*	103.8	3.975
131.3	4.318	126.4	4.280
133.6	4.322*	147.4	4.464
142.3	4.447*	155.0	4.556*
149.1	4.435	161.7	4.531*
155.0	4.556*	168.4	4.577*
161.7	4.531*	175.3	4.698*
168.4	4.577*	180.0	4.652*
175.3	4.698*	182.3	4.669
180.0	4.652*	196.6	4.765*
182.3	4.669	196.7	4.807*
196.6	4.765*	197.6	4.786*
196.7	4.807*	198.7	4.798*
197.6	4.786*	235.0	4.932
198.7	4.798*	237.0	4.957*
235.0	4.932	280.7	5.020*
237.0	4.957*	282.7	5.082
280.7	5.020*	<u>CURVE 2</u>	
282.7	5.082	53.7	2.769 x 10 ⁻²
		56.5	2.800*
		63.0	3.067*
		75.6	3.414*
		89.2	3.741
		108.1	4.027

* Not shown on plot

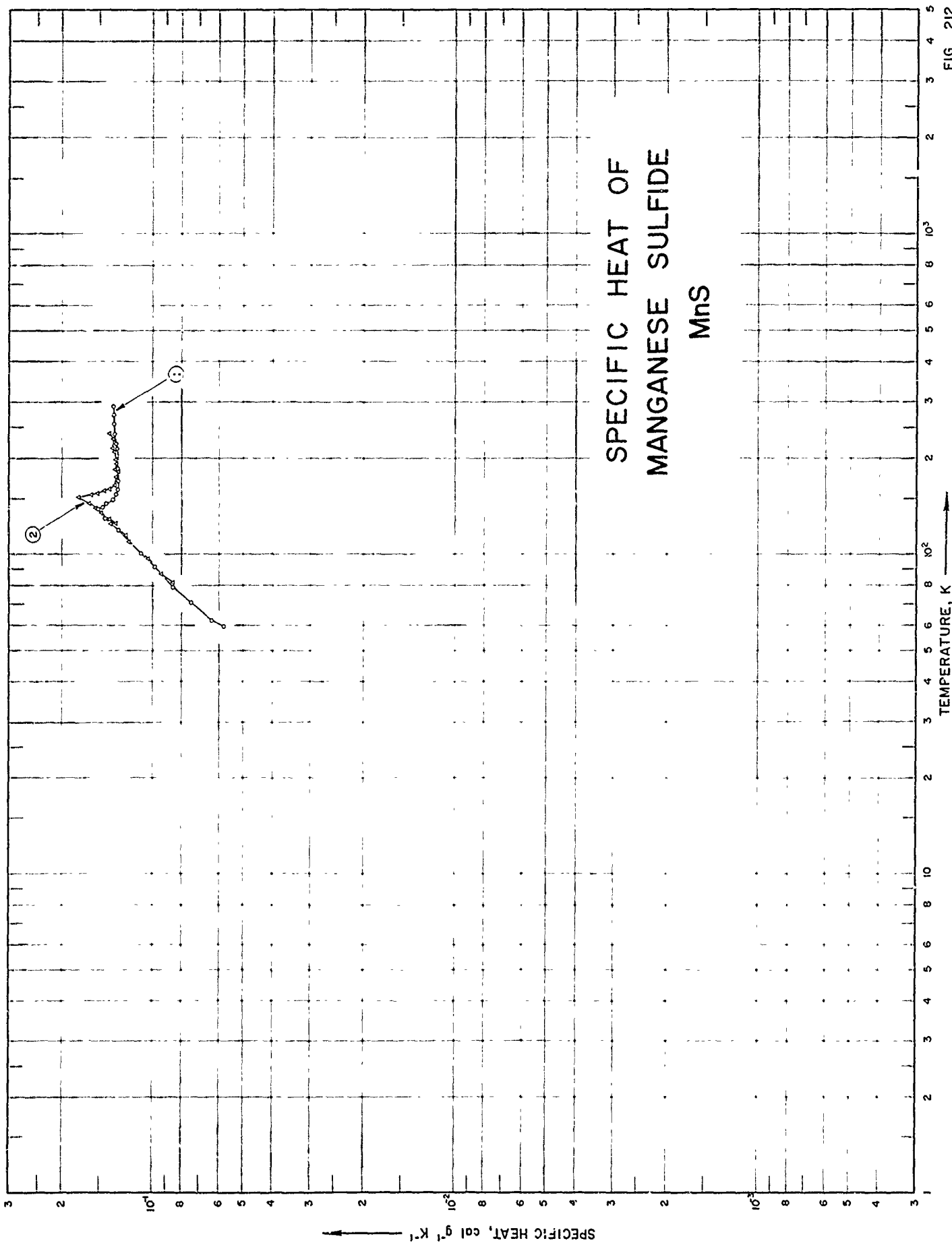

FIG. 212

SPECIFICATION TABLE NO. 212 SPECIFIC HEAT OF MANGANESE SULFIDE MnS

[For Data Reported in Figure and Table No. 212]

Curve No.	Ref. No.	Year	Temp. Range, K	Reported Error, %	Name and Specimen Designation	Composition (weight percent), Specifications and Remarks
1	340	1931	60-297			Prepared from C. P. grade MnSO ₄ ; density = 3.93 g cm ⁻³ at 21.9 C.
2	342	1966	82-240			0.07 O ₂ ; powder sample pressed into 1/2 in. dia pellet using 5K bar pressure; density = 87% of single crystal density.

FIG. 213

SPECIFIC HEAT OF MERCURY SULFIDE HgS

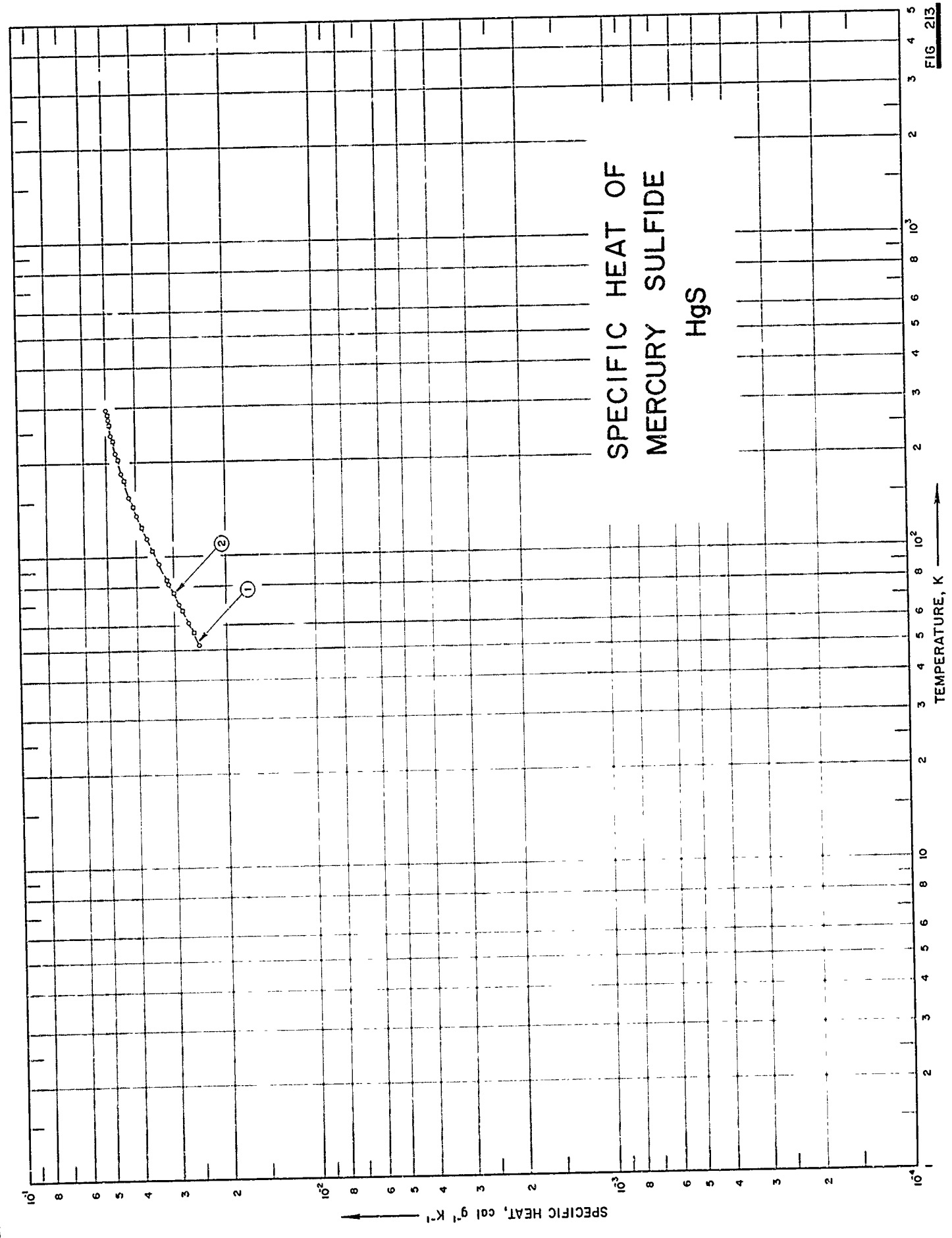

SPECIFICATION TABLE NO. 213 SPECIFIC HEAT OF MERCURY SULFIDE HgS

[For Data Reported in Figure and Table No. 213]

Curve No.	Ref. No.	Year	Temp. Range, K	Reported Error, %	Name and Specimen Designation	Composition (weight percent), Specifications and Remarks
1	343	1962	52-297		Sample A; Cinnabar	86.16 Hg and 13.82 S (86.22 and 13.78 theo).
2	343	1962	53-297		Sample B	99.9 Hg S.

DATA TABLE NO 213 SPECIFIC HEAT OF MERCURY SULFIDE HgS
 [Temperature, T, K; Specific Heat, Cp, Cal g⁻¹K⁻¹]

CURVE 1		CURVE 2 (cont.)	
T	Cp	T	Cp
52.16	2.473 x 10 ⁻²	145.79	4.087 x 10 ⁻²
56.76	2.576*	155.96	4.192*
61.27	2.681	166.07	4.286*
65.51	2.779*	176.14	4.371
70.27	2.886	186.03	4.448*
75.31	2.988*	196.06	4.508*
81.60	3.114	206.15	4.581
86.19	3.198*	216.25	4.637*
94.98	3.358	226.42	4.697*
105.69	3.544*	236.20	4.745
114.95	3.684	245.89	4.788*
124.56	3.828*	256.63	4.835*
136.22	3.974	266.69	4.878
146.03	4.097*	276.54	4.899*
155.92	4.202	286.87	4.934
165.99	4.293*	296.75	4.977*
176.23	4.379*		
186.13	4.461		
196.24	4.521*		
206.38	4.590*		
216.25	4.654		
226.16	4.710*		
236.21	4.766*		
245.87	4.835		
256.74	4.899*		
266.71	4.904*		
276.52	4.908		
286.83	4.951*		
296.51	4.994		

CURVE 2	
T	Cp
52.61	2.474 x 10 ⁻² *
57.21	2.576
62.16	2.695*
67.03	2.806
71.85	2.913*
76.55	3.008
79.90	3.074*
84.08	3.155
94.55	3.348*
104.83	3.525
114.52	3.674*
124.93	3.823
135.84	3.963*

* Not shown on plot

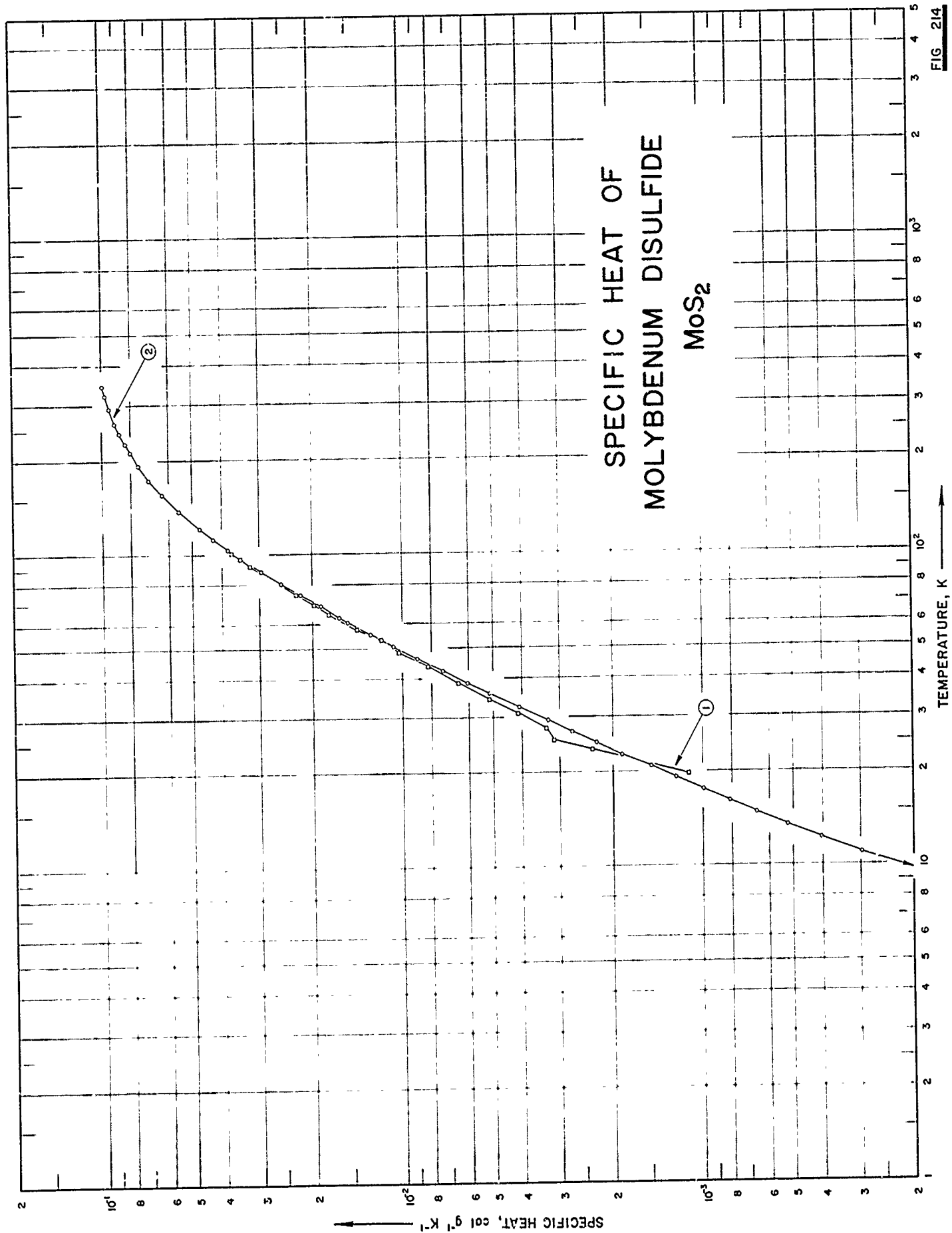

FIG 214

SPECIFICATION TABLE NO. 214 SPECIFIC HEAT OF MOLYBDENUM DISULFIDE MoS_2

[For Data Reported in Figure and Table No. 214]

Curve No.	Ref. No.	Year	Temp. Range, K	Reported Error, %	Name and Specimen Designation	Composition (weight percent), Specifications and Remarks
1	108	1956	20-102			Contains some free carbon and oil. 59.8 Mo, 40.3 S (59.94 and 40.06 theo), 0.1 gangue and 0.0 ± 0.1 C; sample obtained by purifying natural molybdenite from Lyndook Township, Ontario, Canada.
2	327	1955	6-346	0.15-6.0		

DATA TABLE NO. 214 SPECIFIC HEAT OF MOLYBDENUM DISULFIDE MoS₂[Temperature, T, K; Specific Heat, C_p, Cal g⁻¹K⁻¹]

T	C _p	T	C _p
CURVE 1			
19.69	1.118 x 10 ⁻³	216.29	8.140 x 10 ⁻² *
23.55	2.343	226.04	8.358
25.37	3.124	235.80	8.552*
27.53	3.330	245.46	8.739
30.88	4.117	255.14	8.902*
34.16	5.142	264.98	9.058
38.63	6.510	274.92	9.195*
43.71	8.228	284.89	9.339*
48.58	1.028 x 10 ⁻²	294.94	9.439
53.43	1.175	305.13	9.564*
55.32	1.313*	315.29	9.683*
57.66	1.424	325.43	9.782
59.44	1.505*	335.58	9.876*
64.56	1.760	345.67	9.976
69.06	1.975	Series II	
74.58	2.253	5.74	3.623 x 10 ⁻⁶ *
80.96	2.594*	6.92	6.184*
86.68	2.917*	7.87	9.745*
91.99	3.212	8.88	1.487 x 10 ⁻⁴ *
96.94	3.474	9.89	2.149*
101.54	3.727	10.98	2.967
CURVE 2			
Series I			
62.80	1.622 x 10 ⁻²	12.20	4.029
68.23	1.887	13.51	5.254
74.32	2.194	14.80	6.622
80.93	2.548	16.12	8.121
88.29	2.954	17.55	9.932
96.01	3.376*	20.82	1.493
104.35	3.826	22.79	1.862
112.93	4.285	24.86	2.261
121.24	4.718	26.93	2.717
129.59	5.135*	29.24	3.266
138.38	5.538	32.21	4.092
146.77	5.923*	35.64	5.122
155.99	6.303	38.52	6.072
165.33	6.659*	42.21	7.371
174.75	6.990	46.30	8.952
184.21	7.290*	50.77	1.078 x 10 ⁻²
193.47	7.571	55.51	1.284
202.89	7.815*	60.86	1.535
212.34	8.046	60.84	1.524*

* Not shown on plot

SPECIFIC HEAT OF
NICKEL SULFIDE
NiS

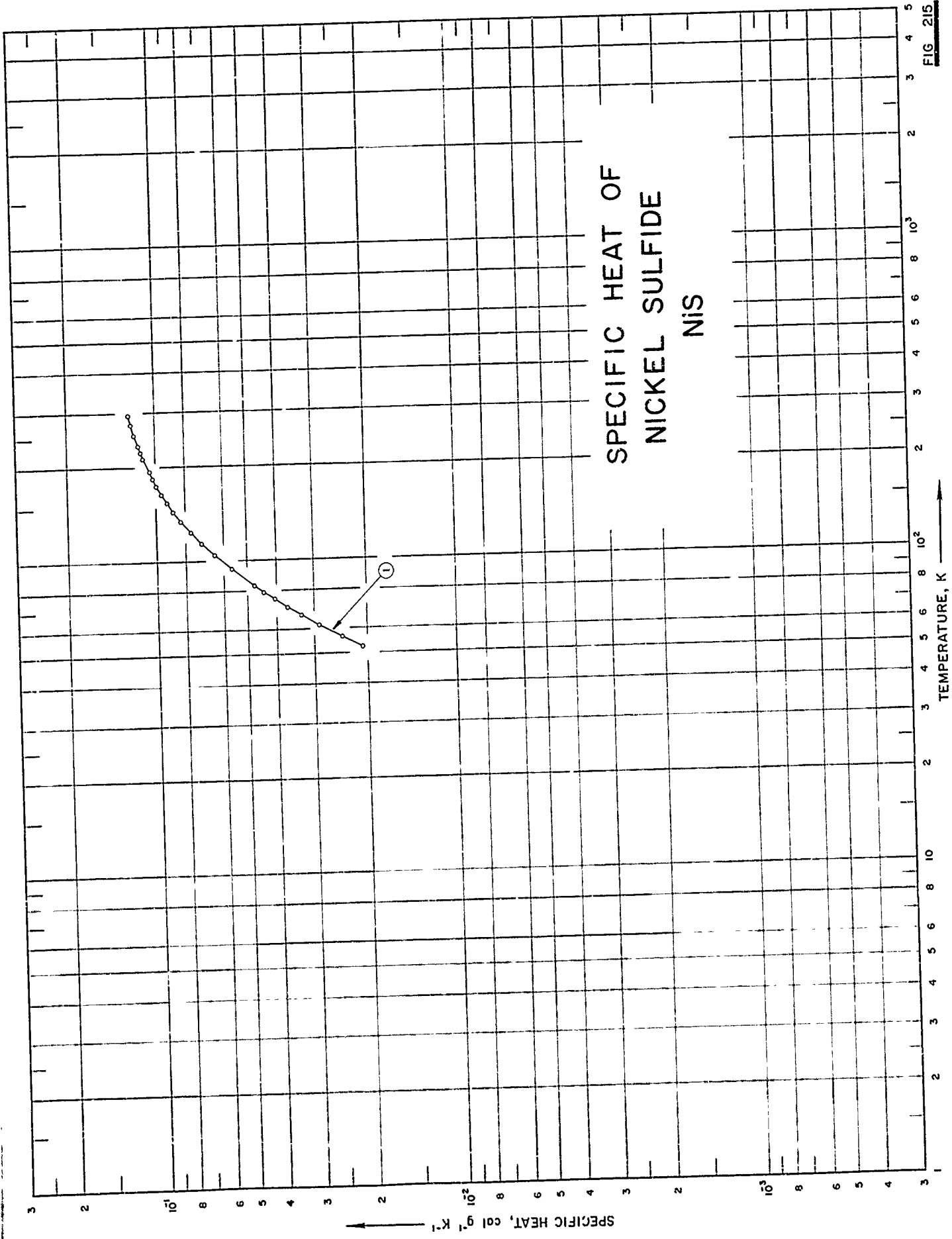

SPECIFICATION TABLE NO. 215 SPECIFIC HEAT OF NICKEL SULFIDE NiS

[For Data Reported in Figure and Table No. 215]

Curve No.	Ref. No.	Year	Temp. Range, K	Reported Error, %	Name and Specimen Designation	Composition (weight percent), Specifications and Remarks
1	339	1964	52-296	± 0.3		64.56 Ni (64.68 theo) and 0.12 acid insoluble material; prepared from pure nickel oxide, and sulfur at temperatures between 530-580 C for 3.5 weeks; heated in vacuum for 3 hrs at 400 C and then slowly cooled to room temperature.

DATA TABLE NO. 215 SPECIFIC HEAT OF NICKEL SULFIDE NIS
 [Temperature, T, K; Specific Heat, C_p , Cal $g^{-1}K^{-1}$]

T	C_p
CURVE 1	
52.44	2.099×10^{-2}
56.51	2.451
61.68	2.918
66.56	3.348
70.76	3.715
75.07	4.097
79.20	4.456
83.19	4.788
94.51	5.687
105.04	6.471
114.62	7.119
124.90	7.745
136.02	8.358
145.96	8.850
155.71	9.266
165.95	9.667
175.82	1.001×10^{-1}
185.95	1.032
196.15	1.061
216.40	1.110
226.22	1.131
236.33	1.150
245.76	1.169
256.70	1.187
266.52	1.203
276.51	1.215
286.74	1.225
296.27	1.239

* Not shown on plot

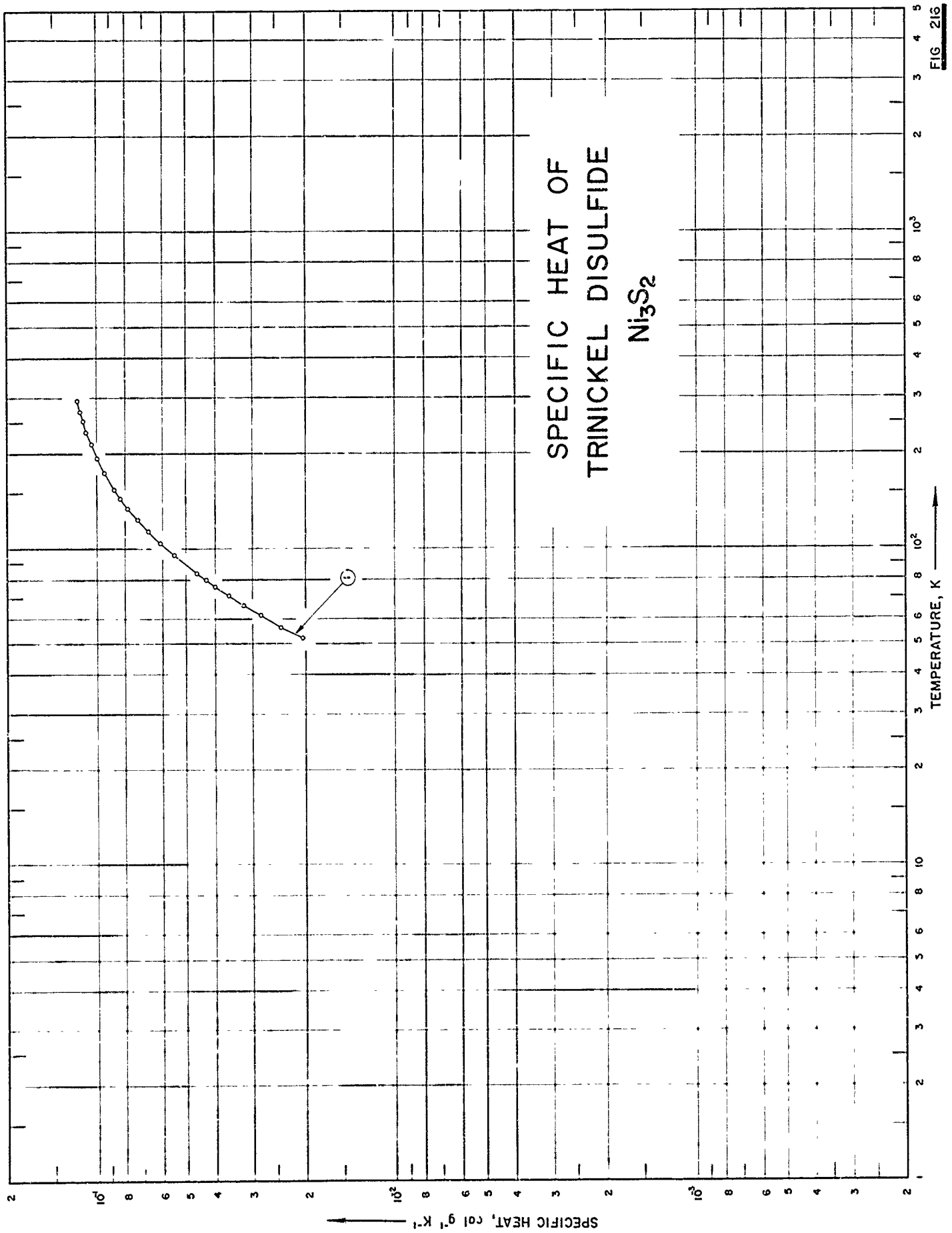

FIG. 216

SPECIFICATION TABLE NO. 216 SPECIFIC HEAT OF TRINICKEL DISULFIDE Ni_3S_2

[For Data Reported in Figure and Table No. 216]

Curve No.	Ref. No.	Year	Temp. Range, K	Reported Error, %	Name and Specimen Designation	Composition (weight per cent), Specifications and Remarks
1	339	1964	53-297	≤ 0.3		73.14 Ni (73.31 theo); prepared from pure nickel oxide and sulfur by repeatedly heating the mixture at 200-525 C until sulfur content of product is slightly lower than theoretical value.

DATA TABLE NO. 216 SPECIFIC HEAT OF TRINICKEL DISULFIDE NiS₂Temperature, T, K; Specific Heat, C_p, Cal g⁻¹K⁻¹

T	C _p
	<u>CURVE 1</u>
52.52	2.069 x 10 ⁻²
56.95	2.424
61.88	2.839
66.60	3.229
71.48	3.619
76.24	4.010
80.04	4.308
84.39	4.637
96.08	5.507
105.38	6.143
114.92	6.743
124.79	7.309
136.03	7.891
146.22	8.353
155.91	8.757
165.94	9.123 ^a
176.06	9.452
185.88	9.739 ^a
195.79	9.993
216.46	1.048 x 10 ⁻¹
226.26	1.066 ^a
236.31	1.085
245.79	1.101 ^a
256.29	1.116
266.92	1.132 ^a
273.31	1.144
286.55	1.157 ^a
296.54	1.169

 Not shown on plot

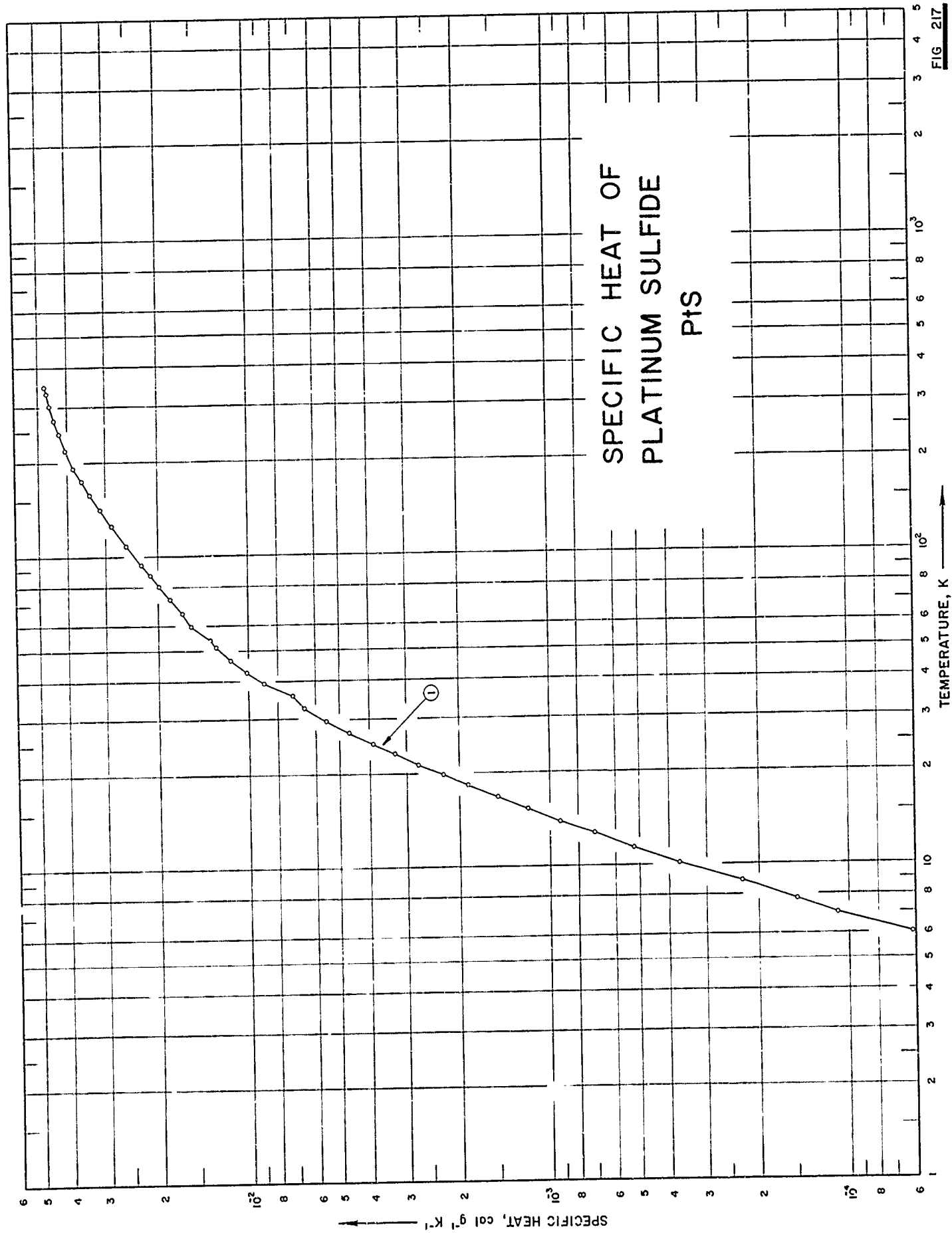
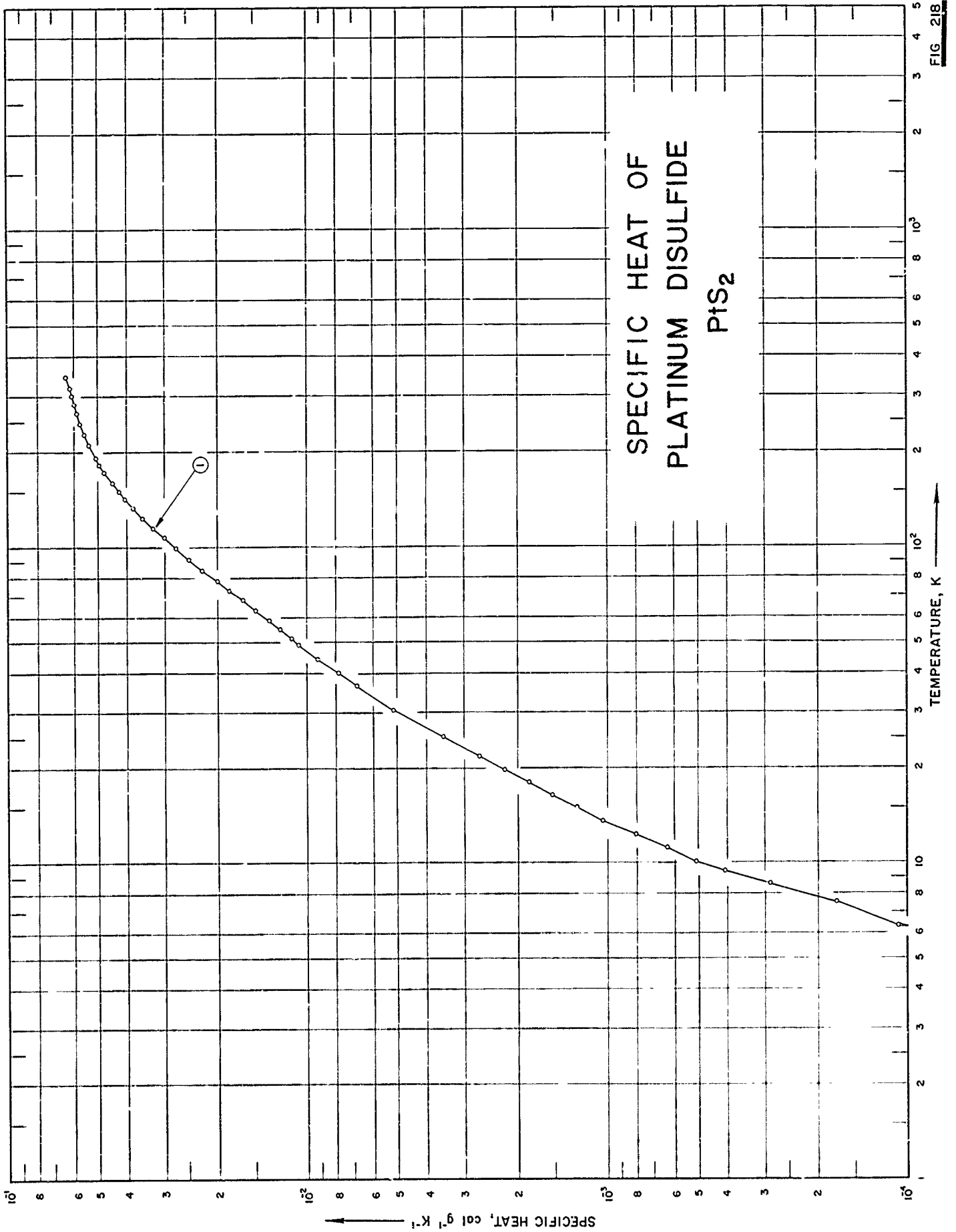

FIG 217

SPECIFICATION TABLE NO. 217 SPECIFIC HEAT OF PLATINUM SULFIDE PtS

[For Data Reported in Figure and Table No. 217]

Curve No.	Ref. No.	Year	Temp. Range, K	Reported Error, %	Name and Specimen Designation	Composition (weight percent), Specifications and Remarks
1	223	1961	6-348	~0.1		~100 PtS, 0.009 volatile material, <0.001 Fe, Pb, 0.0007 Pd, and 0.0001 Au; PtS synthesized in 2 steps; prepared by heating appropriate amount of elements in evacuated and sealed silica tube at 750 C for one day; sintered product crushed and heated with stoichiometric finely divided platinum at 900 C for 2 days; resulting dark grey powder was annealed at 500 C for 2 days and cooled to room temperature over a period of 7 days; density = 624 16 ft ⁻³ .



SPECIFICATION TABLE NO. 218 SPECIFIC HEAT OF PLATINUM DISULFIDE PtS₂

[For Data Reported in Figure and Table No. 218]

Curve No.	Ref. No.	Year	Temp. Range, K	Reported Error, %	Name and Specimen Designation	Composition (weight percent), Specifications and Remarks
1	224	1961	5-347	~0.1		~99.0 PtS ₂ , high purity, <0.090 volatile material. <0.001 Fe, Pb, 0.0007 Pd, and 0.0001 Au; synthesized from stoichiometric amounts of the elements in an evacuated and sealed silica tube by heating to 750 C for one day; annealed at 500 C for several days; cooled slowly to room temperature over another 7 days; measured in a helium atmosphere.

FIG 219

SPECIFIC HEAT OF SILVER SULFIDE (Nonstoichiometric) Ag_xS

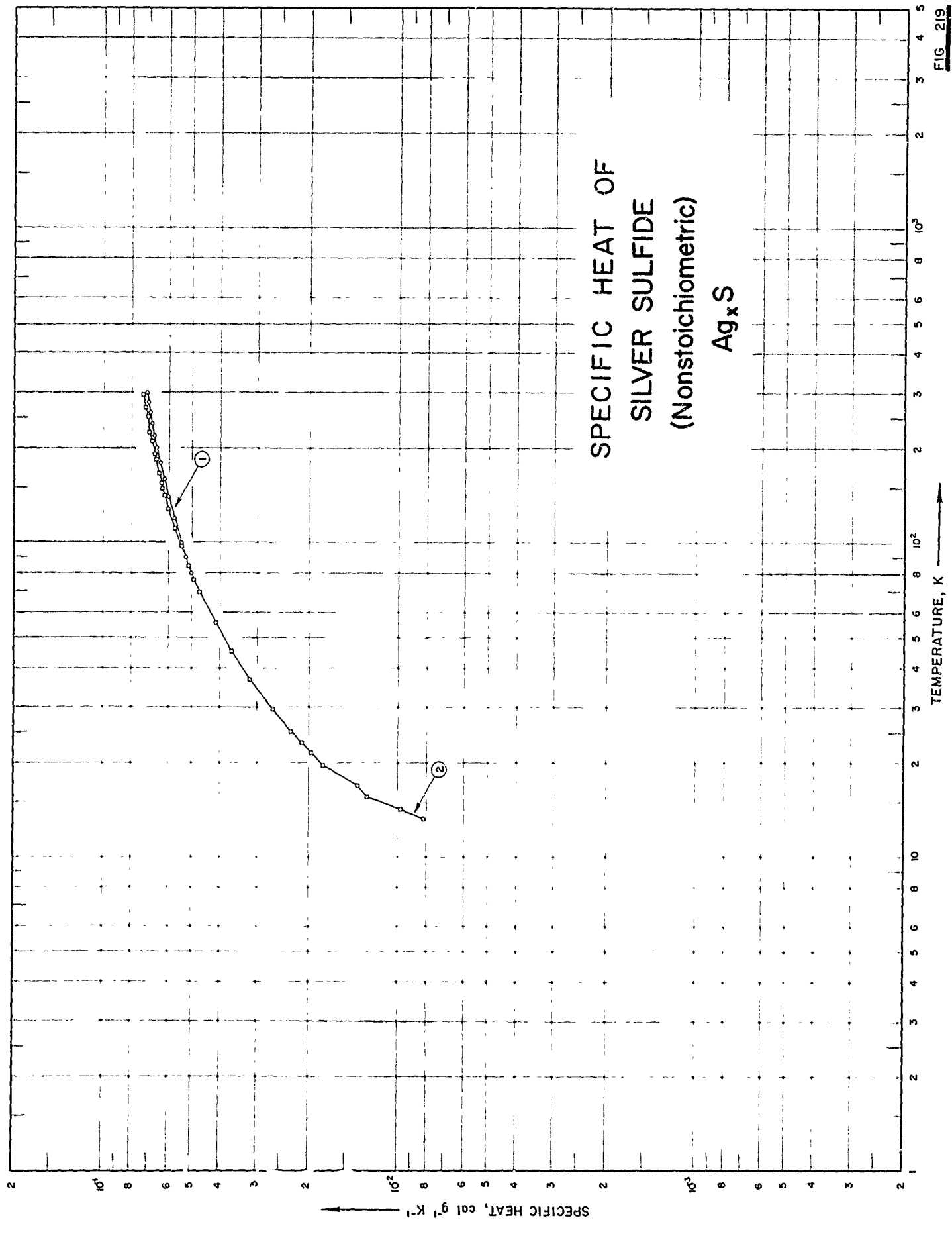

SPECIFICATION TABLE NO. 219 SPECIFIC HEAT OF SILVER SULFIDE (nonstoichiometric) Ag_xS

[For Data Reported in Figure and Table No. 219]

Curve No.	Ref. No.	Year	Temp. Range, K	Reported Error, %	Name and Specimen Designation	Composition (weight percent), Specifications and Remarks
1	160	1959	80-300	3.0-7.0		Ag_2S ; polycrystalline.
2	225	1962	13-296			99.99 $Ag_{1.99}S$; crushed under argon atmosphere.

DATA TABLE NO. 219 SPECIFIC HEAT OF SILVER SULFIDE (nonstoichiometric) Ag_xS
 [Temperature, T, K; Specific Heat, C_p , Cal $g^{-1}K^{-1}$]

T	C_p	T	C_p
<u>CURVE 1</u>			
	5.049×10^2	<u>CURVE 2 (cont.)</u>	
80	5.277	128.81	6.075×10^2
90	5.460	135.47	6.132*
100	5.739	141.10	6.213
120	6.054	148.96	6.229*
140	6.270	149.41	6.338
160	6.465	155.47	6.387
180	6.633	161.71	6.464*
200	6.756	167.65	6.517
220	6.876	177.17	6.565*
240	6.972	184.62	6.650
260	7.068	192.46	6.736
280	7.155	200.15	6.768*
300		210.18	6.885
		217.08	6.946*
		224.87	7.003
		251.00	7.088
		245.33	7.124*
		254.35	7.157*
		260.17	7.181*
		268.66	7.234
		282.40	7.299*
		296.15	7.372
<u>CURVE 2</u>			
	8.267×10^{-3}		
13.23	9.848		
14.14	1.285 $\times 10^2$		
15.56	1.378		
16.95	1.807		
19.60	1.974		
21.58	2.120		
23.17	2.225*		
23.91	2.310		
25.14	2.488*		
27.26	2.590*		
28.22	2.663		
29.67	2.910*		
32.87	3.194		
36.62	3.457*		
40.85	3.668		
45.56	4.138		
55.91	4.409*		
61.58	4.738		
69.85	4.819*		
72.16	4.952		
76.86	5.042*		
80.78	5.147		
84.38	5.236*		
86.74	5.398*		
91.04	5.455		
97.29	5.568*		
97.41	5.751		
112.46	5.994*		
123.49			

* Not shown on plot

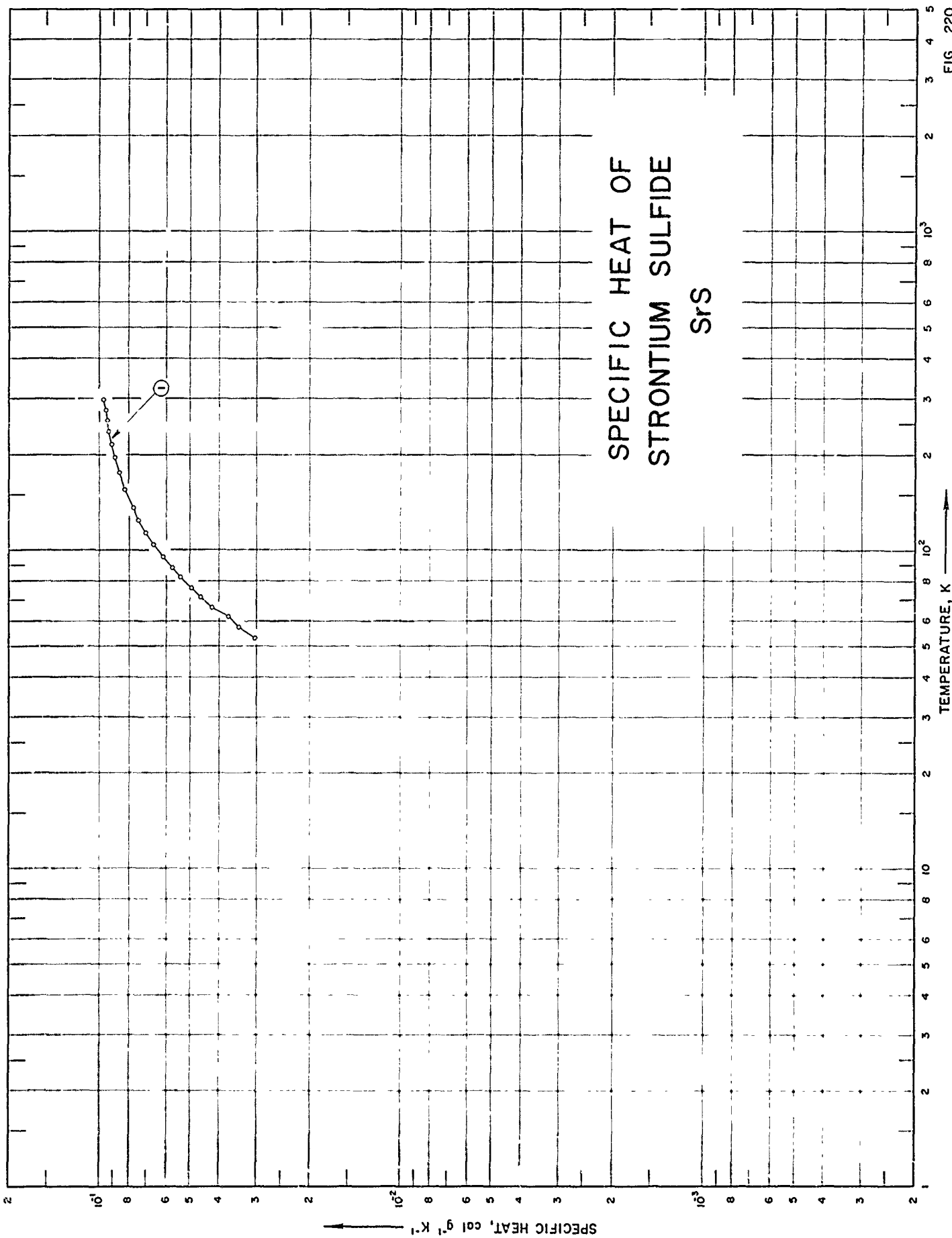

FIG. 220

SPECIFICATION TABLE NO. 220 SPECIFIC HEAT OF STRONTIUM SULFIDE SrS

[For Data Reported in Figure and Table No. 220]

Curve No.	Ref. No.	Year	Temp. Range, K	Reported Error, %	Name and Specimen Designation	Composition (weight percent), Specifications and Remarks
1	305	1960	53-298			99.16 SrS, 0.83 SrSO ₄ , 0.01 SiO ₂ ; prepared from reagent grade strontium carbonate and HCl; heated in a stream of pure hydrogen at 1000 C for 4-5 hrs.

DATA TABLE NO. 220 SPECIFIC HEAT OF STRONTIUM SULFIDE SrS

[Temperature, T, K; Specific Heat, Cp, Cal g⁻¹K⁻¹]

T	Cp
<u>CURVE 1</u>	
53.25	3.054 x 10 ⁻²
57.72	3.450
62.24	3.741
66.86	4.230
71.74	4.617
76.67	4.988
82.82	5.404
89.05	5.733
95.77	6.171
105.19	6.649
114.78	7.045
124.97	7.425
136.74	7.784
146.15	8.049*
156.51	8.283
166.41	8.480*
176.53	8.655
186.23	8.789*
196.40	8.906
206.37	9.040*
216.54	9.148
226.20	9.240*
236.18	9.324
246.33	9.390*
256.83	9.466
266.40	9.511*
276.90	9.599
286.79	9.658*
296.27	9.725*
298.15	9.725

* Not shown on plot

FIG. 221

SPECIFIC HEAT OF THORIUM DISULFIDE ThS₂

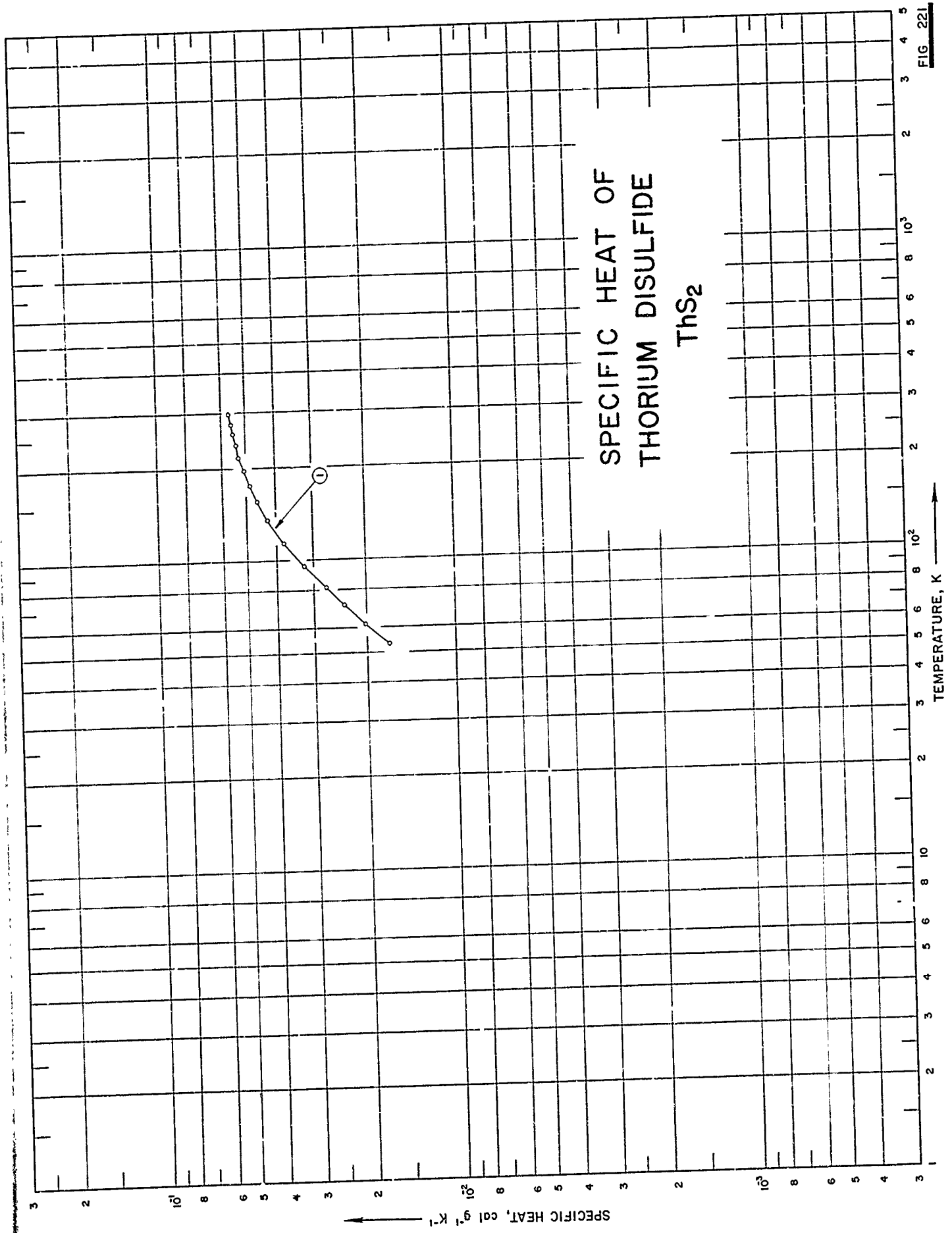

SPECIFICATION TABLE NO. 221 SPECIFIC HEAT OF THORIUM DISULFIDE ThS₂

[For Data Reported in Figure and Table No. 221.]

Curve No.	Ref. No.	Year	Temp. Range, K	Reported Error, %	Name and Specimen Designation	Composition (weight percent), Specifications and Remarks
1	306	1959	53-297	0.3		78.54 Th and 21.43 S (78.35 and 21.65 theo).

DATA TABLE NO. 221 SPECIFIC HEAT OF THORIUM DISULFIDE ThS_2
 [Temperature, T, K; Specific Heat, C_p , Cal $\text{g}^{-1}\text{K}^{-1}$]

T	C_p
CURVE 1	
53.24	1.678×10^{-2}
57.43	1.839*
61.96	2.019
66.49	2.195*
71.07	2.375
75.83	2.549*
81.16	2.701
85.94	2.918*
95.05	3.205
105.06	3.508*
114.65	3.758
124.76	3.998*
135.97	4.237
145.72	4.430*
155.49	4.588
166.02	4.740*
175.92	4.855
186.03	4.973*
195.93	5.061
206.36	5.152*
216.33	5.247
225.91	5.314*
236.56	5.368
245.74	5.429*
256.21	5.490
266.05	5.534*
275.98	5.581
286.66	5.625*
296.18	5.672

* Not shown on plot

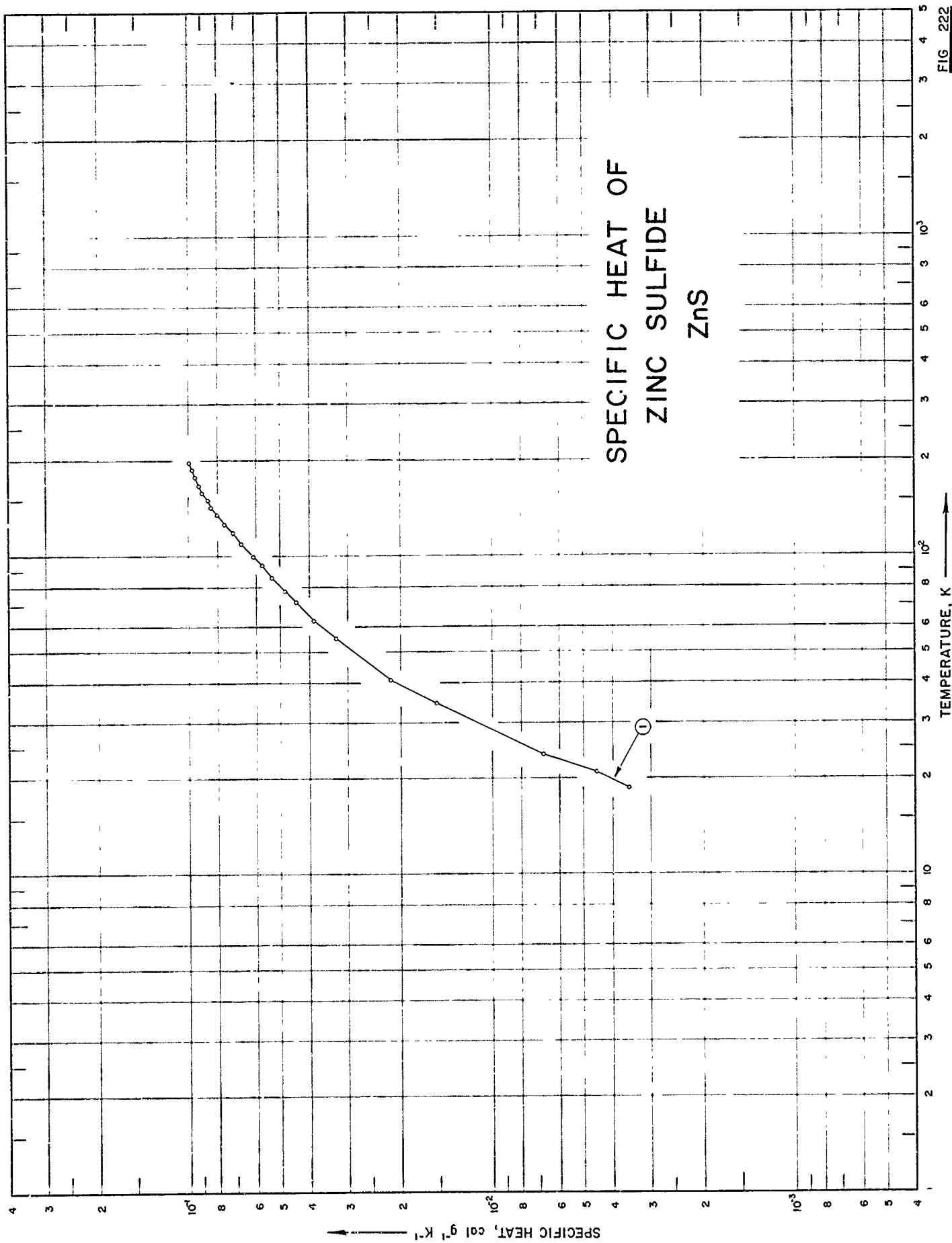

FIG 222

SPECIFICATION TABLE NO. 222 SPECIFIC HEAT OF ZINC SULFIDE ZnS

[For Data Reported in Figure and Table No. 222]

Curve No.	Ref. No.	Year	Temp. Range, K	Reported Error, %	Name and Specimen Designation	Composition (weight percent), Specifications and Remarks
1	68	1928	19-196			

DATA TABLE NO. 222 SPECIFIC HEAT OF ZINC SULFIDE ZnS

[Temperature, T, K; Specific Heat, Cp, Cal g⁻¹K⁻¹]

T	C _p
CURVE 1	
18.65	3.542 x 10 ⁻³
20.95	4.533
23.75	6.809
34.20	1.546 x 10 ⁻²
40.90	2.167
55.00	3.289
62.90	3.864
71.50	4.427
77.20	4.845
85.80	5.346
93.10	5.749
99.80	6.194
109.40	6.736
117.90	7.178
126.40	7.617
135.10	8.102
142.70	8.462
150.30	8.612
158.40	9.006
167.90	9.284
177.90	9.514
187.00	9.731
196.30	9.900

SPECIFIC HEAT OF DIBISMUTH TRITELLURIDE Bi_2Te_3

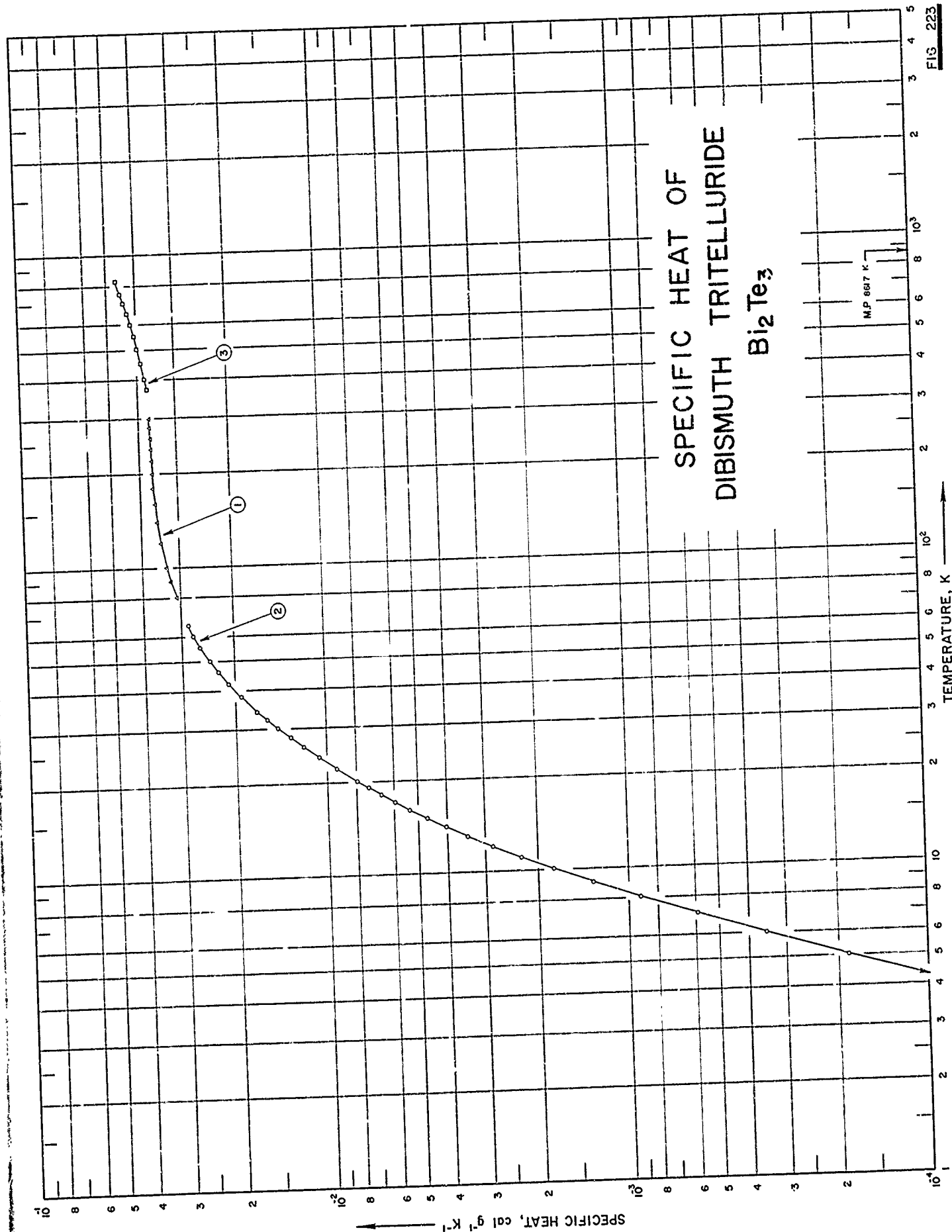

SPECIFICATION TABLE NO. 223 SPECIFIC HEAT OF DI-BISMUTH TRITELLURIDE Bi_2Te_3

[For Data Reported in Figure and Table No. 223]

Curve No.	Ref. No.	Year	Temp. Range, K	Reported Error, %	Name and Specimen Designation	Composition (weight percent). Specifications and Remarks
1	160	1959	80-300	3-7		Polycrystalline.
2	218	1961	1.5-65	1.0-3.0		Recrystallized twice to increase the purity; coated with polymer varnish 3F-2.
3	219	1962	373-823	2.0		Zone-refined.

DATA TABLE NO. 223 SPECIFIC HEAT OF BISMUTH TRITELLURIDE Bi_2Te_3 [Temperature, T, K.; Specific Heat, C_p , Cal $\text{g}^{-1}\text{K}^{-1}$]

T	C_p	T	C_p
	<u>CURVE 1</u>		<u>CURVE 2 (cont.)</u>
80	3.09×10^{-2}	42	2.115×10^{-2}
90	3.23	44	2.207*
100	3.33	46	2.293
120	3.45	48	2.379*
140	3.54	50	2.447
160	3.59	55	2.616
180	3.62	60	2.755
200	3.64	65	2.859
220	3.66		<u>CURVE 3</u>
240	3.67	373	3.7460×10^{-2}
260	3.68	400	3.8000
280	3.70	450	3.9000
300	3.71	500	4.0000
	<u>CURVE 2</u>	550	4.1000
1.5	3.259×10^{-5}	600	4.2000
2	6.518*	650	4.3000
3	2.785×10^{-5}	700	4.4000
4	7.821*	750	4.5000
5	1.843×10^{-4}	800	4.6000
6	3.496	823	4.6460
7	5.925		
8	9.154		
9	1.324×10^{-3}		
10	1.786		
11	2.290		
12	2.850		
13	3.442		
14	4.0587		
15	4.681		
16	5.332		
17	5.984		
18	6.666		
19	7.317		
20	7.969		
22	9.302		
24	1.066×10^{-2}		
26	1.200		
28	1.330		
30	1.460		
32	1.588		
34	1.706		
36	1.816*		
38	1.920		
40	2.014*		

* Not shown on plot

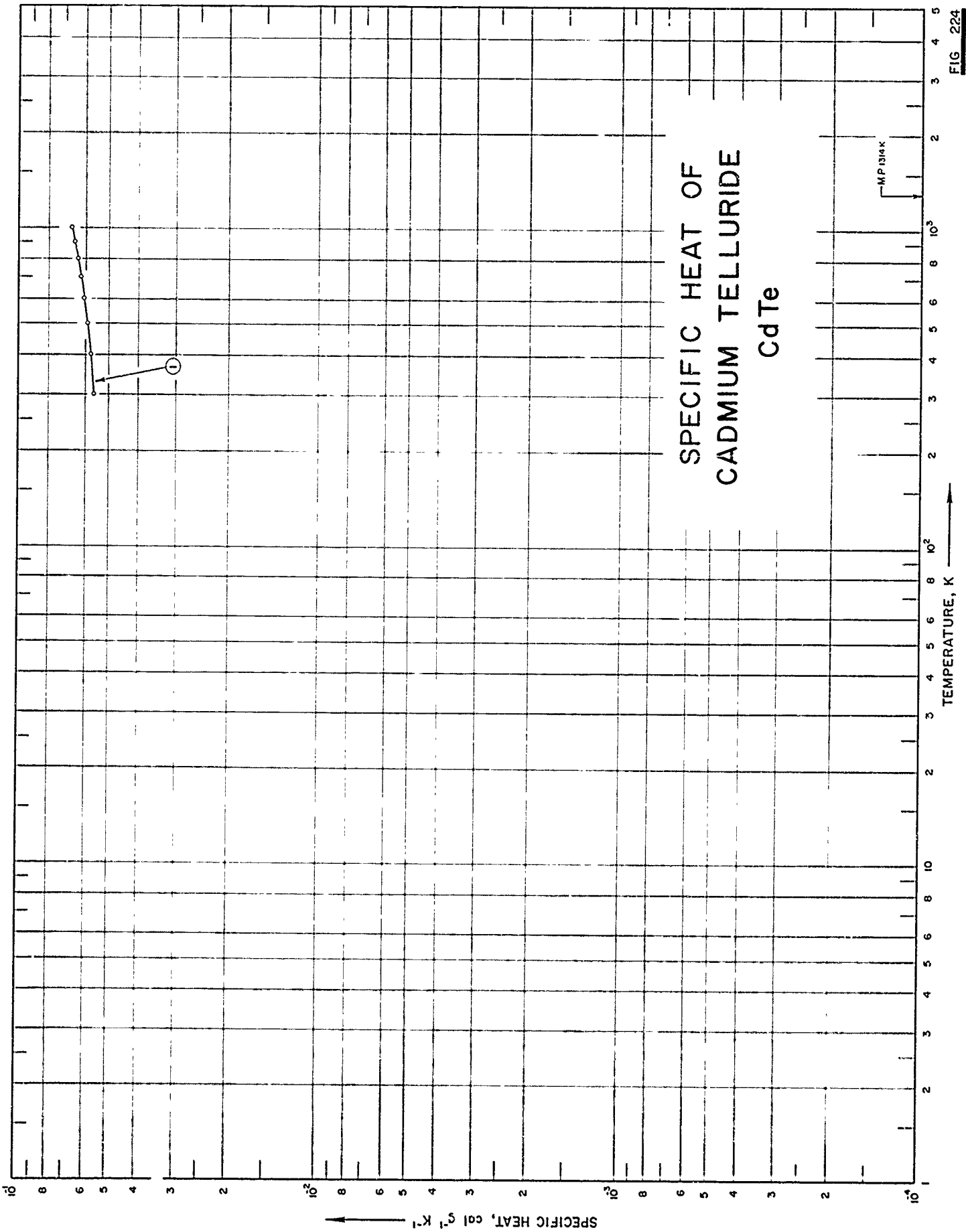

SPECIFICATION TABLE NO. 224 SPECIFIC HEAT OF CADMIUM TELLURIDE CdTe

[For Data Reported in Figure and Table No. 224]

Curve No.	Ref. No.	Year	Temp. Range, K	Reported Error, %	Name and Specimen Designation	Composition (weight percent), Specifications and Remarks
1	54	1965	300-1000	4.5		~100 CdTe; traces of Sn.

DATA TABLE NO. 224 SPECIFIC HEAT OF CADMIUM TELLURIDE CdTe

[Temperature, T, K; Specific Heat, C_p , Cal $g^{-1}K^{-1}$]

T	C_p
<u>CURVE 1</u>	
300	5.612 x 10 ⁻²
400	5.762
500	5.912
600	6.062
700	6.208
800	6.358
900	6.508
1000	6.658

FIG. 225

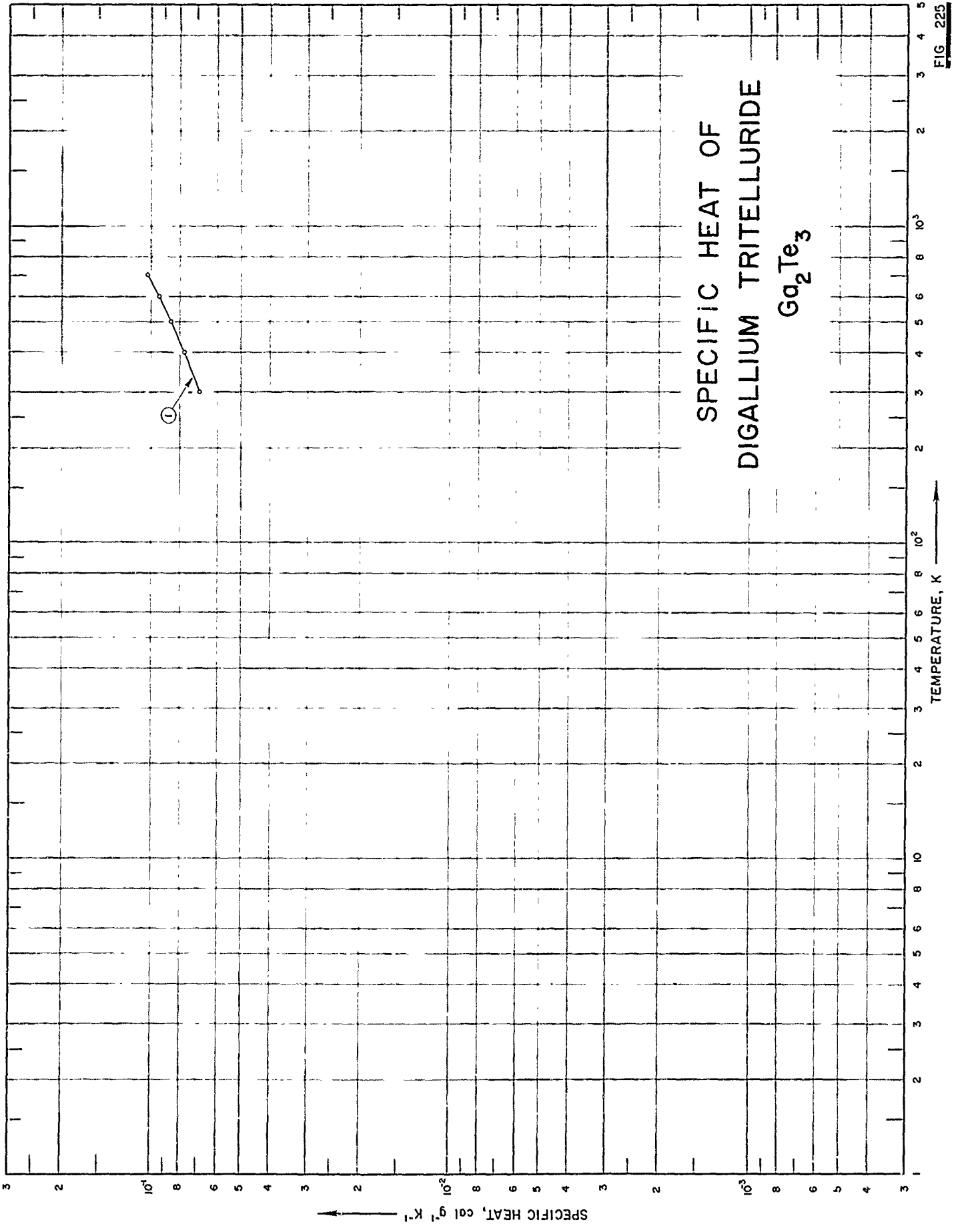

SPECIFICATION TABLE NO. 225 SPECIFIC HEAT OF DIGALLIUM TRITELLURIDE Ge_2Te_3

[For Data Reported in Figure and Table No. 225]

Curve No.	Ref. No.	Year	Temp. Range, K	Reported Error, %	Name and Specimen Designation	Composition (weight percent), Specifications and Remarks
1	423	1963	300-700			

DATA TABLE NO. 225 SPECIFIC HEAT OF DIGALLIUM TRITELLURIDE Ga_2Te_3
[Temperature, T, K; Specific Heat, C_p , Cal $\text{g}^{-1}\text{K}^{-1}$]

T	C_p
	<u>CURVE 1</u>
300	6.907×10^{-2}
400	7.759
500	8.611
600	9.446
700	1.031×10^{-1}

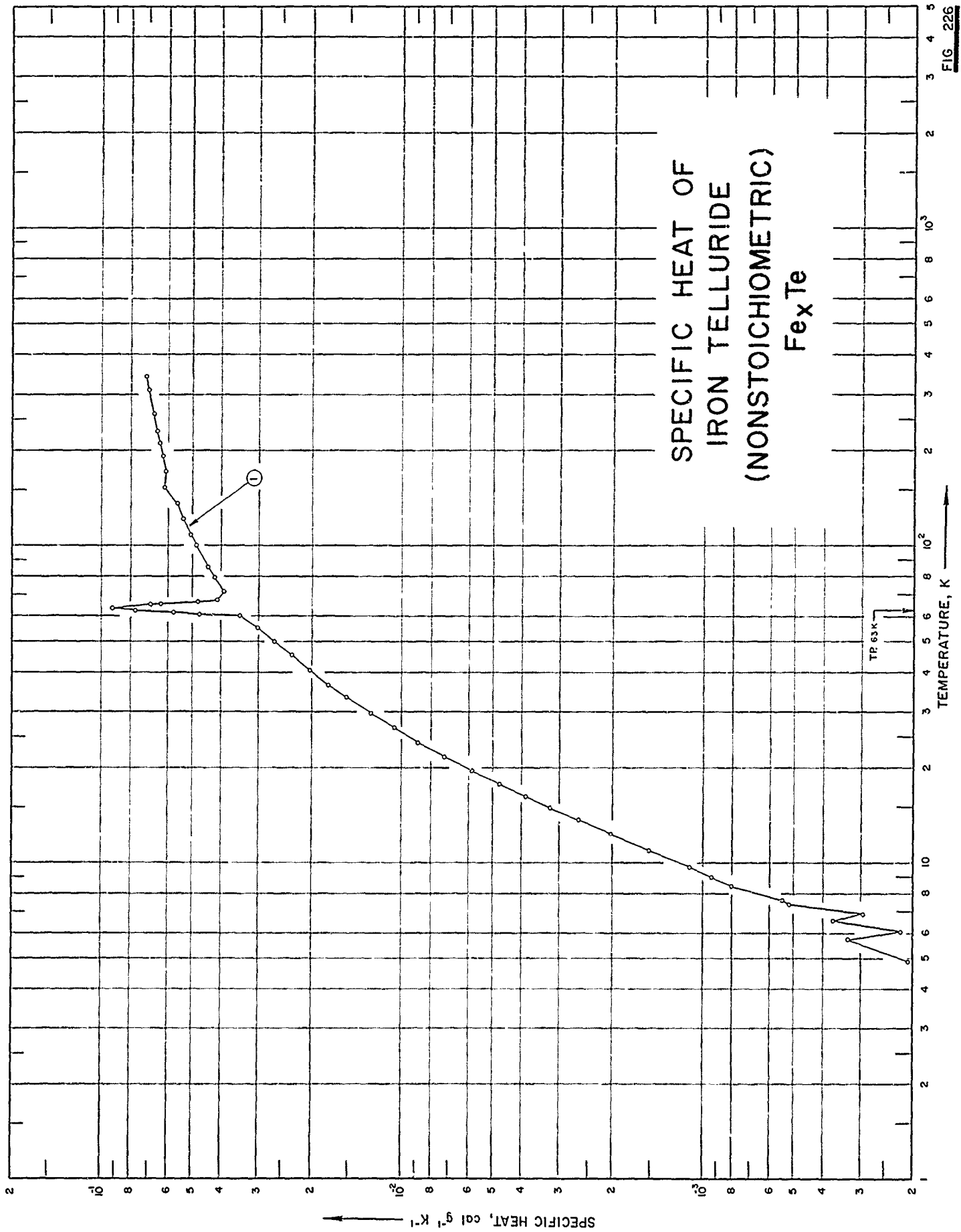

FIG. 226

SPECIFICATION TABLE NO. 226 SPECIFIC HEAT OF IRON TELLURIDE (nonstoichiometric) Fe_xTe

[For Data Reported in Figure and Table No. 226]

Curve No.	Ref. No.	Year	Temp. Range, K	Reported Error, %	Name and Specimen Designation	Composition (weight percent), Specifications and Remarks
1	52	1962	6-341	0.1-5.0		~100 $Fe_{1.11}Te$; iron impurities: 0.01 each Ni and Si, and 0.001 Mn, tellurium impurities: 0.01 Fe and traces of Al, Pb, and Mg; heated for 1 wk at 700 C and cooled; fragmented; heated at 400 C for 2 wks and cooled to room temperature at the rate of 50 C per day.

DATA TABLE NO. 226 SPECIFIC HEAT OF IRON TELLURIDE Fe_xTe (nonstoichiometric)Temperature, T, K; Specific Heat, C_p , Cal $\text{g}^{-1}\text{K}^{-1}$

T	C_p	T	C_p	T	C_p
CURVE I					
Series I					
121.50	5.378×10^{-2}	30.08	1.313×10^{-2} *	67.49	4.040×10^{-2} *
126.46	5.468*	33.11	1.526	68.60	3.908*
136.37	5.615	36.41	1.753	70.58	3.895*
143.21	5.763*	40.39	2.021	226.85	6.554*
152.48	6.216	45.06	2.332	236.34	6.617*
162.00	6.011*	49.92	2.662	245.87	6.680*
171.70	6.116	54.98	3.015	242.07	6.628*
181.40	6.216^*	60.56	4.756	250.49	6.680*
191.11	6.306	65.62	6.380	260.03	6.738
200.75	6.380*	71.92	3.948	269.74	6.791*
210.35	6.448	79.24	4.203	279.49	6.838*
219.86	6.512*	85.93	4.449	289.33	6.886*
229.35	6.575	92.70	4.663*	299.46	6.928*
Series II					
6.09	2.204×10^{-4}	100.20	4.878	309.83	7.002
6.89	2.947	108.36	5.086	320.23	7.049*
7.60	5.431	116.65	5.278*	330.82	7.097*
8.41	8.014	124.93	5.452*	341.65	7.144
8.97	9.332	Series IV			
9.65	1.107×10^{-3}	51.66	2.781×10^{-2} *		
10.93	1.513	56.78	3.150*		
12.33	2.025	60.08	3.470		
13.62	2.589	61.85	5.784		
14.84	3.211	63.61	9.248		
16.15	3.875	65.41	6.538*		
17.66	4.761	67.30	4.109		
19.45	5.862	69.32	3.891*		
21.54	7.239	71.87	3.920*		
23.93	8.863	75.08	4.059*		
26.51	1.064×10^{-2}	Series V			
29.55	1.276	52.06	2.808×10^{-2} *		
Series III					
4.87	2.083×10^{-4}	57.35	3.198*		
5.70	3.290	60.49	3.543*		
6.56	3.707	61.60	4.718*		
7.37	5.188	62.44	7.730		
8.38	8.014*	63.08	9.364*		
9.43	1.044×10^{-2} *	63.67	9.248*		
10.64	1.418*	64.25	8.948*		
11.89	1.845*	64.77	8.241*		
		65.28	6.907		
		66.24	4.790		

* Not shown on plot

FIG. 227

SPECIFIC HEAT OF
IRON DITELLURIDE
FeTe2

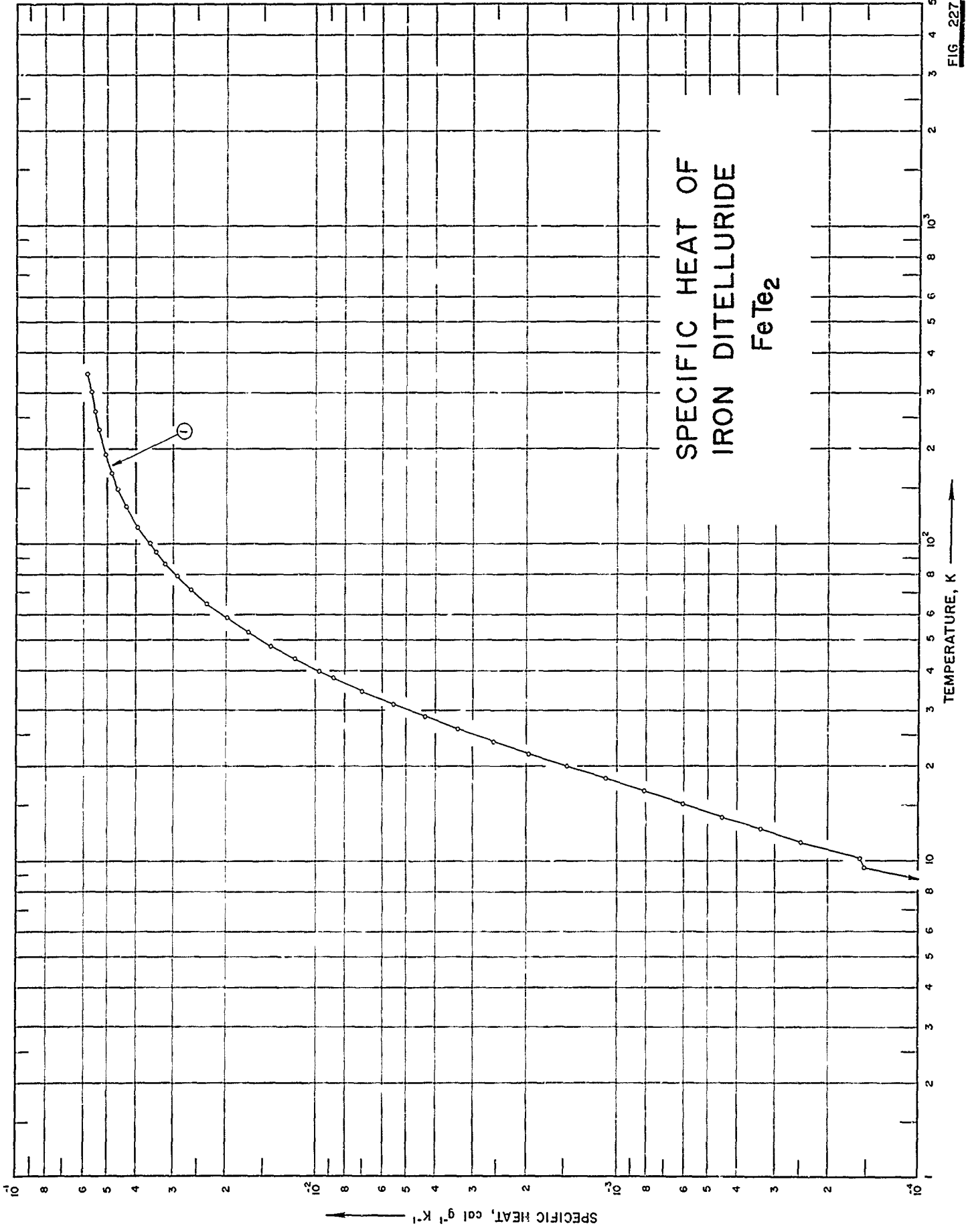

SPECIFICATION TABLE NO. 227 SPECIFIC HEAT OF IRON DITELLURIDE FeTe_2

[For Data Reported in Figure and Table No. 227]

Curve No.	Ref. No.	Year	Temp. Range, K	Reported Error, %	Name and Specimen Designation	Composition (weight percent)	Specifications and Remarks
1	220	1959	7-345	0.1-5.0			~100 FeTe_2 ; iron impurities: 0.01 each Ni and Si, and 0.001 Mn, tellurium impurities: 0.01 Fe, and traces of Al, Mg and Pb; heated for 1 wk at 700 C and cooled; fragmented; heated at 400 C for 2 wks and cooled to room temperature at the rate of 50 C per day.

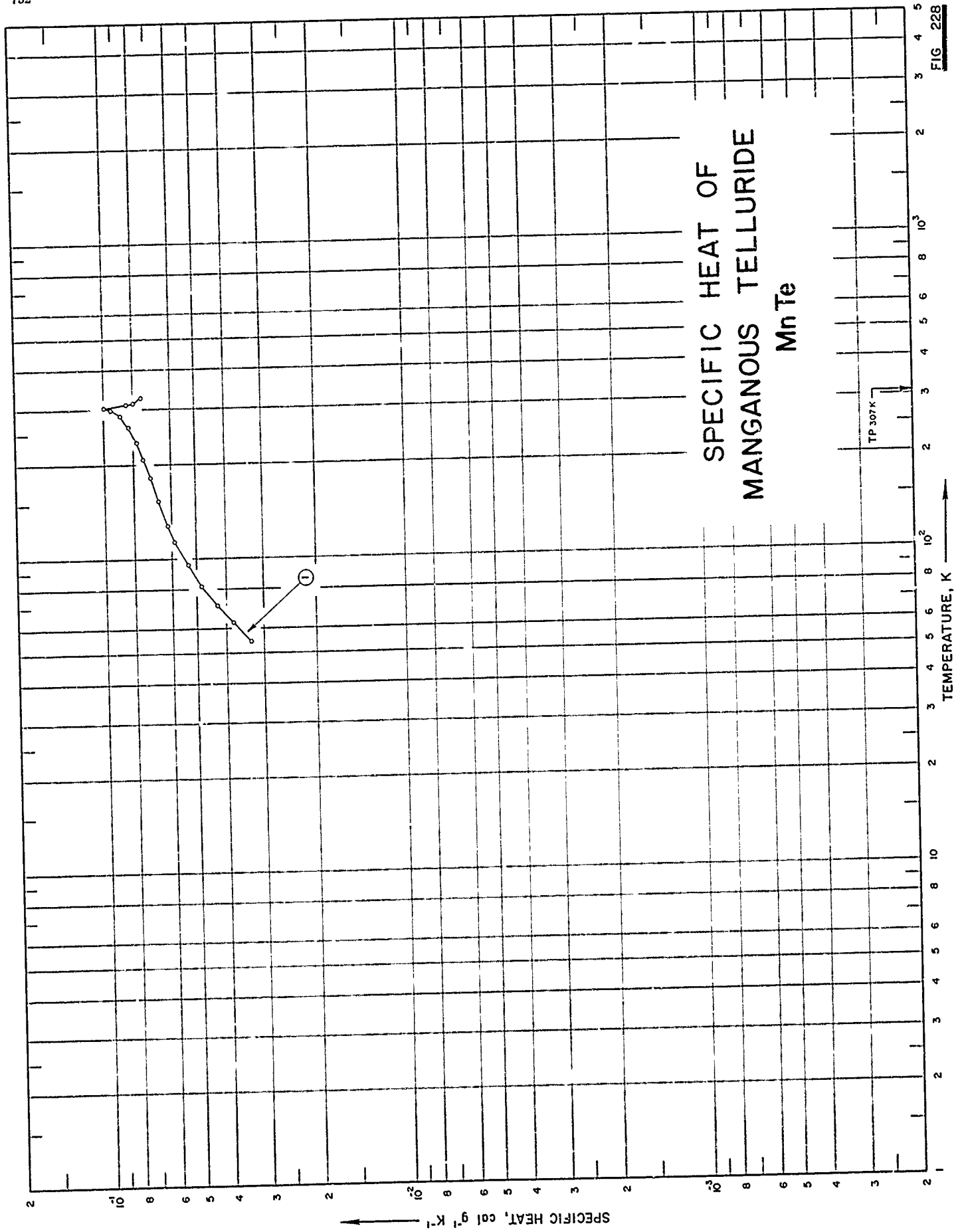

SPECIFICATION TABLE NO. 228 SPECIFIC HEAT OF MANGANOUS TELLURIDE MnTe

[For Data Reported in Figure and Table No. 228]

Curve No.	Ref. No.	Year	Temp. Range, K	Reported Error, %	Name and Specimen Designation	Composition (weight percent), Specifications and Remarks
1	221	1939	55-327			99.57 MnTe.

DATA TABLE NO. 228 SPECIFIC HEAT OF MANGANOUS TELLURIDE MnTe
 [Temperature, T, K; Specific Heat, C_p , Cal g⁻¹K⁻¹]

T	C_p	T	C_p
CURVE 1		CURVE 1 (cont.)	
10^{-2}		10^{-1}	
54.5	3.31	304.4	1.007
58.3	3.56*	307.4	1.004*
62.5	3.81	310.5	8.404
66.4	4.05*	313.7	7.992
70.7	4.31	316.9	7.730*
75.3	4.56*	320.4	7.637*
81.5	4.82	323.7	7.533*
82.0	4.84*	327.0	7.549
85.6	4.99*		
86.6	5.03*		
95.2	5.35		
100.2	5.505*		
104.9	5.654*		
109.4	5.780*		
113.6	5.911		
117.6	6.037*		
119.9	6.092*		
121.4	6.114*		
127.6	6.223		
131.2	6.371*		
144.8	6.502*		
153.8	6.651		
162.8	6.788*		
172.3	6.946*		
181.6	7.051		
190.7	7.182*		
199.8	7.330*		
208.3	7.445		
217.5	7.565*		
227.0	7.691*		
236.2	7.850		
245.7	8.015*		
255.1	8.152*		
264.4	8.338		
273.3	8.541*		
277.2	8.634*		
281.0	8.754*		
286.0	8.891		
289.8	9.028*		
293.3	9.171*		
295.2	9.395*		
297.8	9.499		
298.1	9.466*		
301.5	9.751*		

* Not shown on plot

FIG 229

SPECIFIC HEAT OF NICKEL TELLURIDE (Nonstoichiometric) NiTex

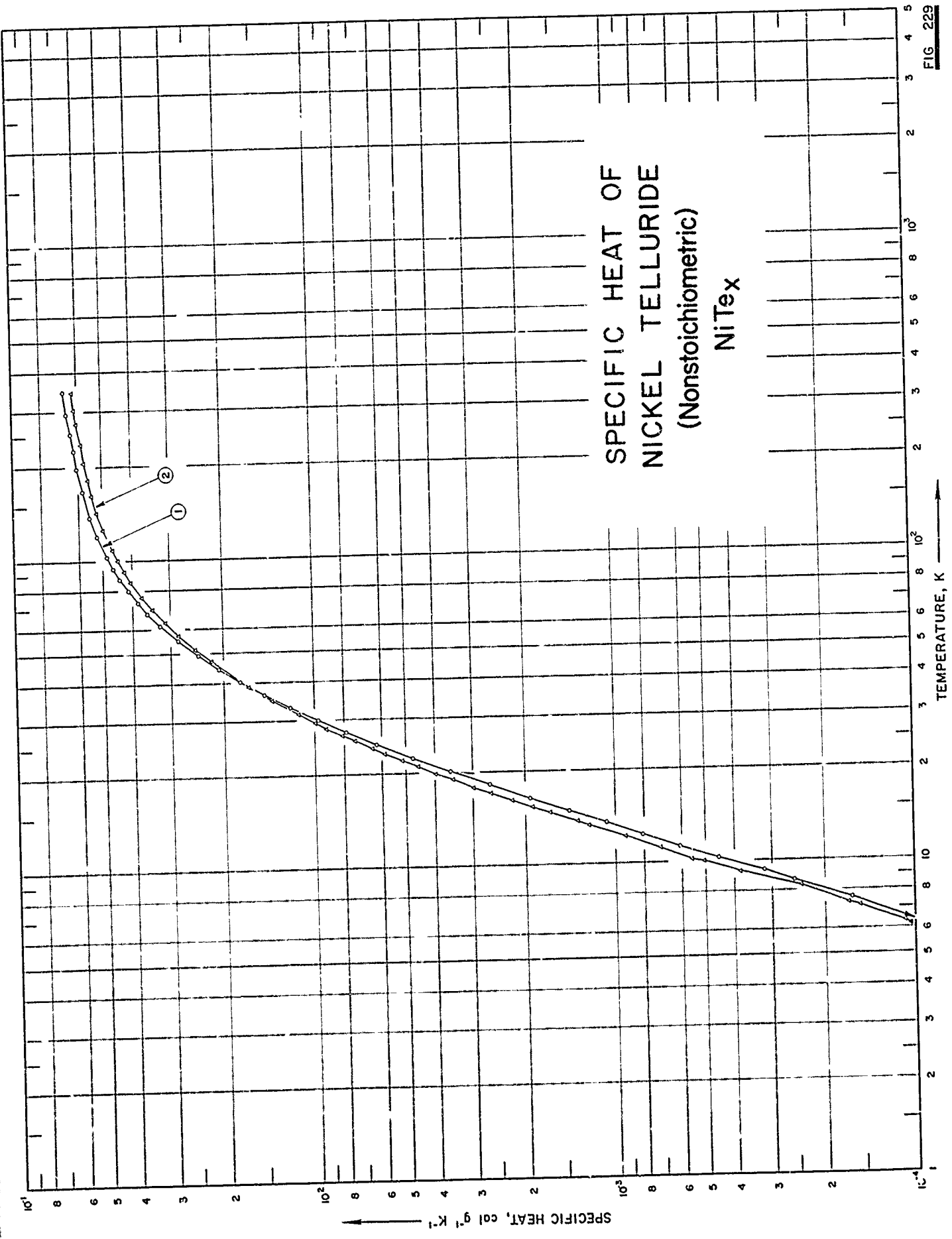

SPECIFICATION TABLE NO. 229 SPECIFIC HEAT OF NICKEL TELLURIDE (nonstoichiometric) NiTe_x

[For Data Reported in Figure and Table No. 229]

Curve No.	Ref. No.	Year	Temp. Range, K	Reported Error, %	Name and Specimen Designation	Composition (weight percent), Specifications and Remarks
1	222	1958	5-347	0.1		>99.99 $\text{NiTe}_{1.1}$; fused for 2 hrs at 1000 C, cooled, fragmented, annealed in vacuo at 500 C for 30 days; cooled to room temperature over a period of 2 days, additional heating for 2 wks at temperature gradually decreasing from 500 to 300 C.
2	222	1958	6-346	0.1		>99.99 $\text{NiTe}_{1.5}$; same as above.

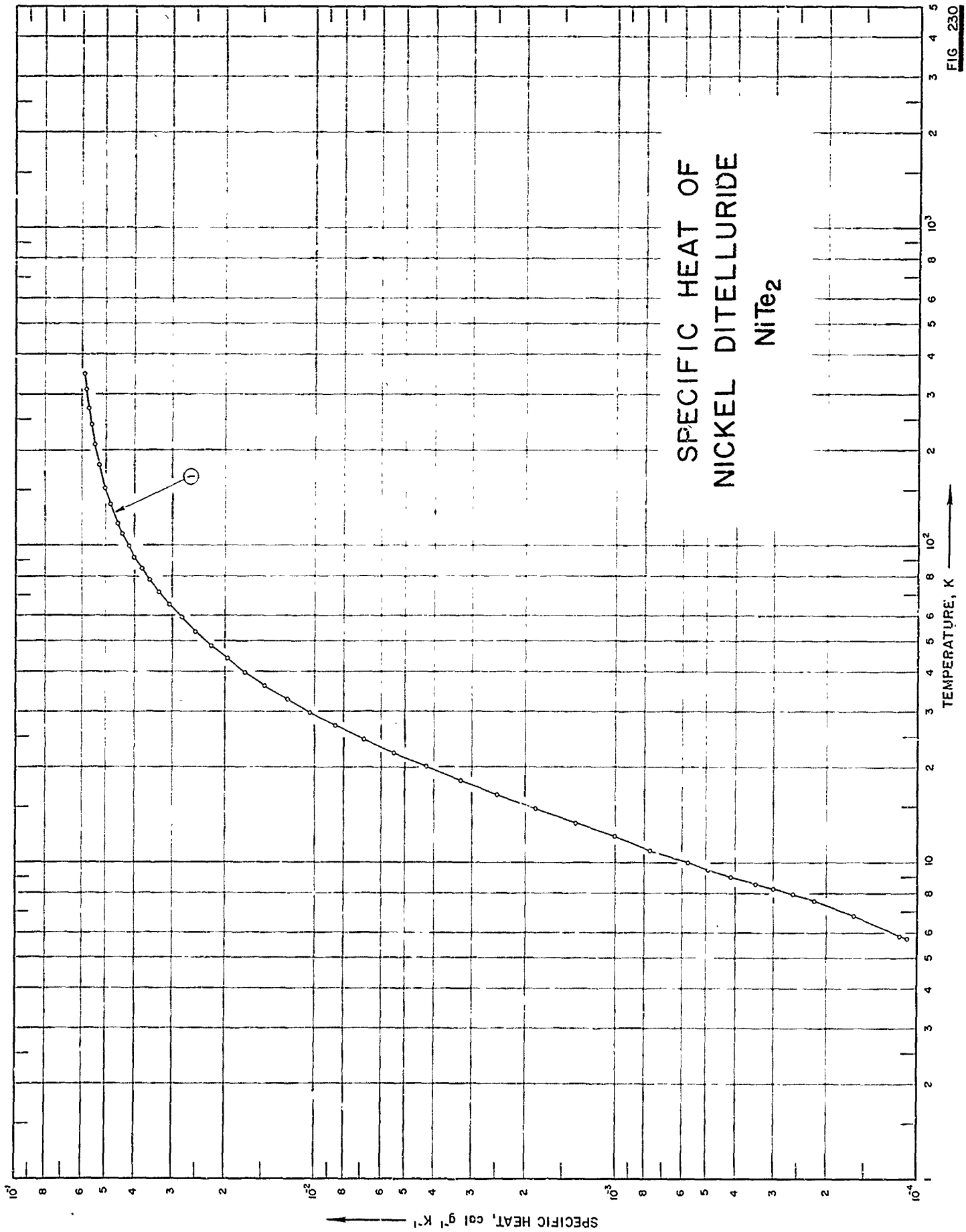

FIG. 230

SPECIFICATION TABLE NO. 230 SPECIFIC HEAT OF NICKEL DITELLURIDE NiTe_2

[For Data Reported in Figure and Table No. 230 J

Curve No.	Ref. No.	Year	Temp. Range, K	Reported Error, %	Name and Specimen Designation	Composition (weight percent), Specifications and Remarks
1	222	1958	6-348	0.1		>99.99 NiTe_2 ; fused for 2 hrs at 1000 C, cooled, fragmented, annealed in vacuo at 500 C for 30 days, cooled to room temperature over a period of 2 days; additional heating for 2 wks at temperature gradually decreasing from 500 to 300 C.

FIGURE SHOWS ONLY 1 OF THE CURVES REPORTED IN TABLE

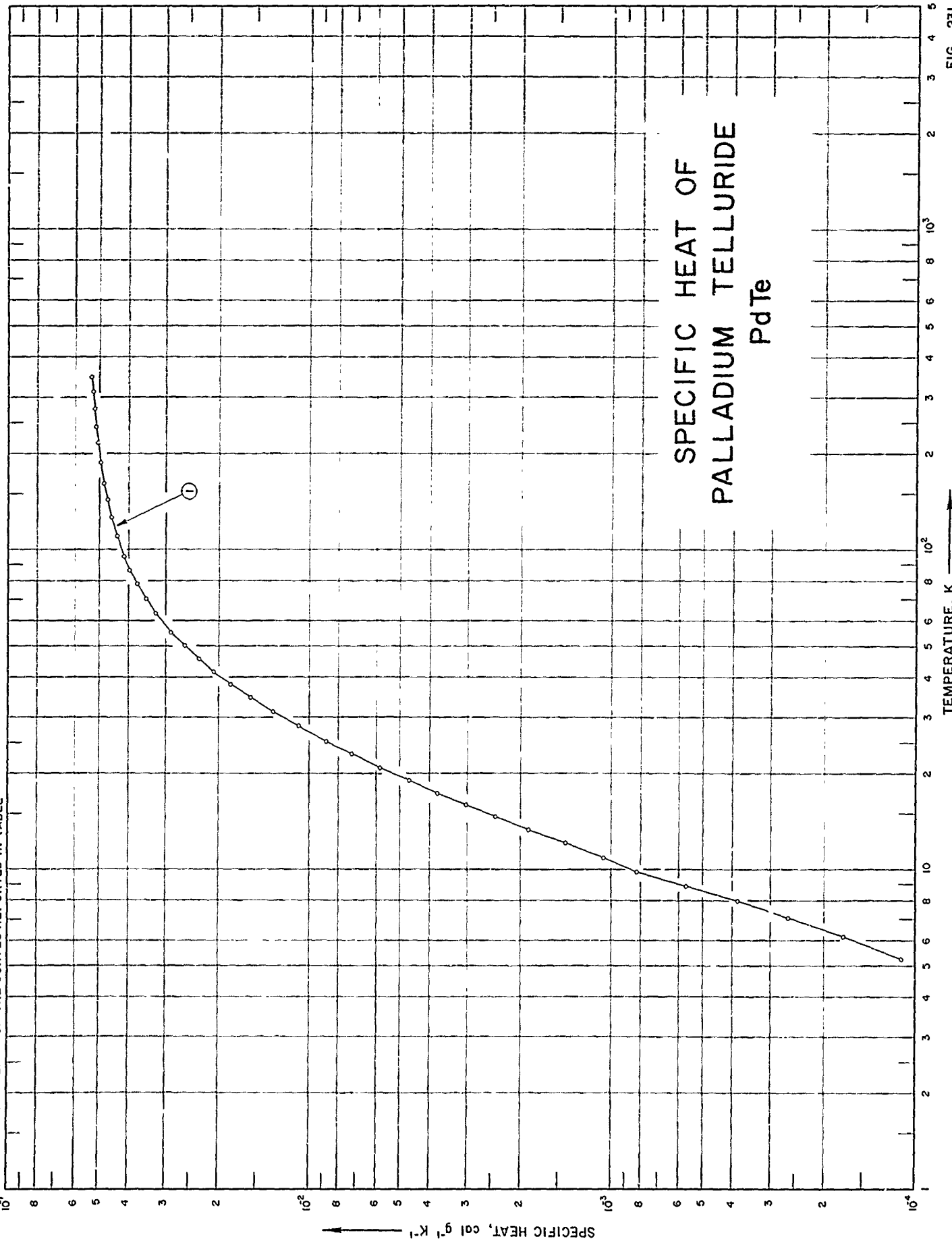

SPECIFIC HEAT OF
PALLADIUM TELLURIDE
PdTe

TEMPERATURE, K

SPECIFICATION TABLE NO. 231 SPECIFIC HEAT OF PALLADIUM TELLURIDE PdTe

[For Data Reported in Figure and Table No. 231.]

Curve No.	Ref. No.	Year	Temp. Range, K	Reported Error, %	Name and Specimen Designation	Composition (weight percent), Specifications and Remarks
1	223	1961	5-347	~0.1		Impurities: 0.006 volatile matter, 0.007 Au, 0.005 Pt, 0.003 Ag, 0.002 Fe, 0.001 Rh, and 0.0002 Pb; prepared from stoichiometric amounts of palladium and tellurium heated in evacuated and sealed silica tube to 800 C; kept in molten state for 2 hrs, cooled, annealed for 7 days at 500 C and cooled to room temperature over a two-day period.
2	424	1965	2-7			PdTe _{1.04} ; prepared from 99.8 Pd supplied by Johnson, Matthey and Co., Ltd., and 99.999 Te supplied by the American Smelting and Refining Co.; annealed 1 wk at 450 C.
3	424	1965	1.6-7			PdTe; same as above.

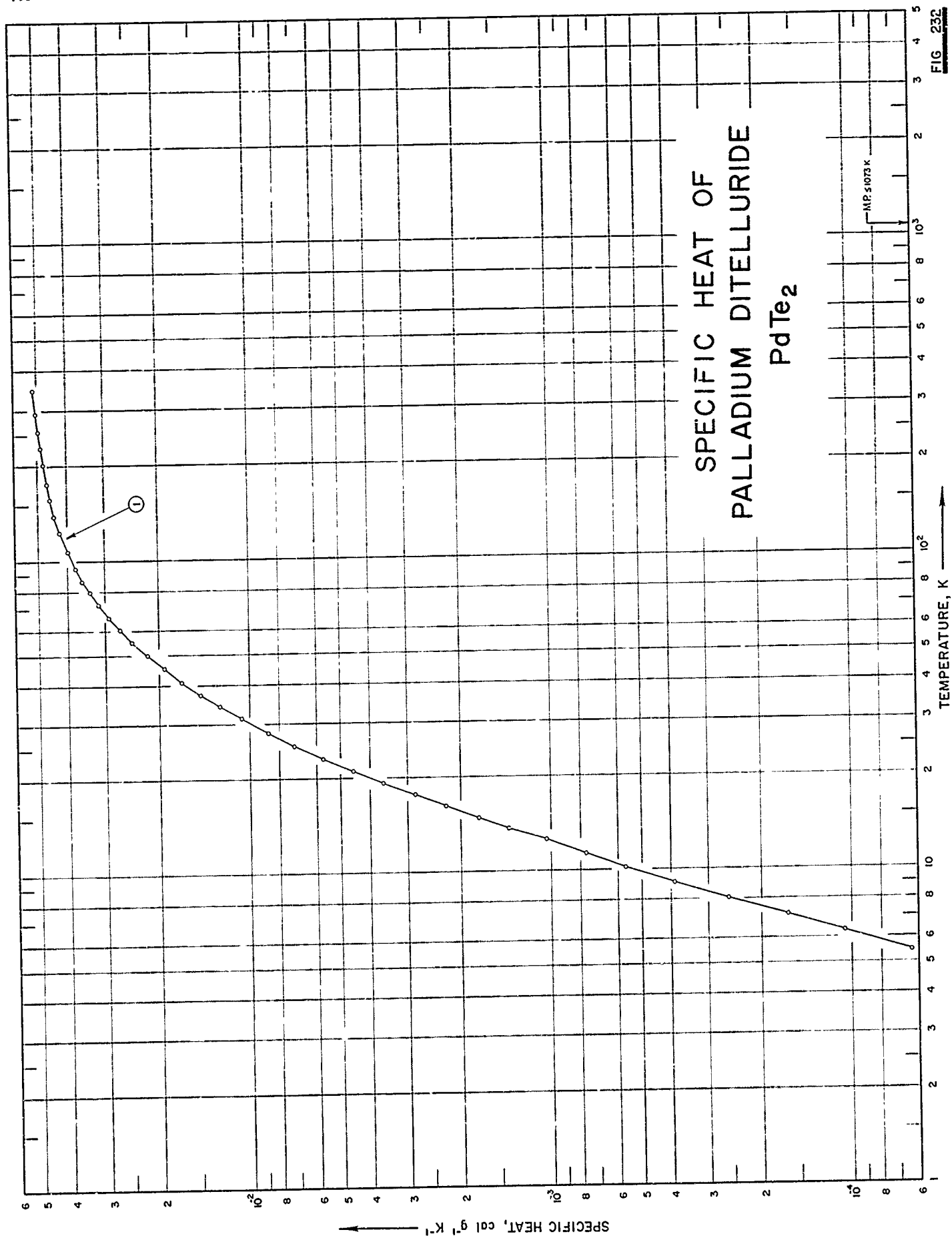

FIG. 232

SPECIFICATION TABLE NO. 232 SPECIFIC HEAT OF PALLADIUM DITELLURIDE PdTe₂

[For Data Reported in Figure and Table No. 232]

Curve No.	Ref. No.	Year	Temp. Range, K	Reported Error, %	Name and Specimen Designation	Composition (weight percent), Specifications and Remarks
1	224	1961	5-346	~0.1		99.999 tellurium composition, palladium impurities: 0.007 Au, 0.006 SiO ₂ , 0.005 Pt, 0.003 Ag, 0.002 Fe, 0.0002 Pb, 0.001 Rh, and 0.006 volatile matter; prepared by heating mixture of elements at 800 C, kept molten for 2 hrs, after cooling, the sample was fragmented, sealed in a silica tube and annealed at 500 C for 7 days and cooled to room temperature over a period of two days.

DATA TABLE NO. 232 SPECIFIC HEAT OF PALLADIUM DITELLURIDE PdTe₂[Temperature, T, K; Specific Heat, Cp, Cal g⁻¹K⁻¹]

T	CURVE I		T	CURVE I (cont.)	
	Series I	C _p		Series I (cont.)	C _p
106.97		3.996 x 10 ⁻¹	16.13		2.244 x 10 ⁻³
115.44		4.126*	17.55		2.837
123.62		4.242	19.15		3.612
131.64		4.331*	21.00		4.557
139.67		4.411	23.06		5.721
147.95		4.485*	25.40		7.107
156.84		4.549	28.00		8.725
166.07		4.615*	28.64		9.123*
175.21		4.668	31.23		1.078 x 10 ⁻²
173.55		4.651*	34.08		1.260
182.89		4.709*	37.24		1.462
192.27		4.745*	40.93		1.687
201.40		4.787	45.18		1.936
210.33		4.823*	49.96		2.198
210.19		4.823*	54.99		2.453
219.26		4.859*	60.26		2.694
228.28		4.886	65.95		2.936
237.29		4.914*	72.16		3.157
247.17		4.944*	79.21		3.384
255.19		4.967	86.75		3.594
264.33		4.983*	94.35		3.765
273.44		4.997*	102.14		3.911*
282.61		5.033*			
291.69		5.055			
300.74		5.072*			
309.84		5.088*			
391.07		5.094*			
328.32		5.121*			
337.48		5.141*			
346.37		5.155			

Series II	
5.42	6.360 x 10 ⁻⁵
6.30	1.161 x 10 ⁻⁴
7.13	1.632
8.07	2.572
9.07	3.880
10.14	5.677
11.32	7.657
12.53	1.039 x 10 ⁻³
13.73	1.393
13.59	1.349*
14.81	1.741

* Not shown on plot

FIG 233

SPECIFIC HEAT OF PLATINUM TELLURIDE PtTe

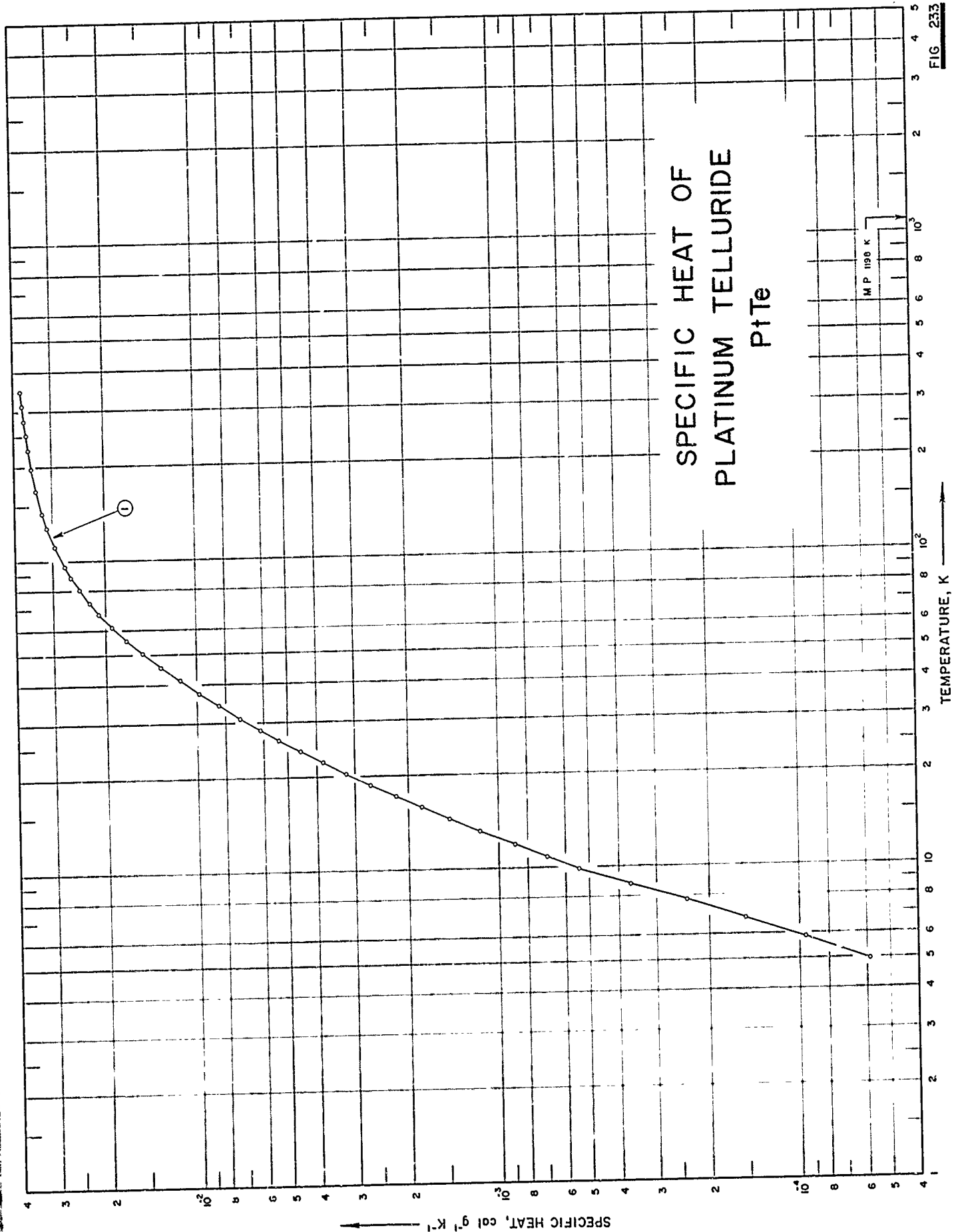

SPECIFICATION TABLE NO. 233 SPECIFIC HEAT OF PLATINUM TELLURIDE PtTe

[For Data Reported in Figure and Table No. 233]

Curve No.	Ref. No.	Year	Temp. Range, K	Reported Error, %	Name and Specimen Designation	Composition (weight percent), Specifications and Remarks
1	223	1961	5-347	~0.10		99.999 Te, platinum impurities: 0.009 volatile material, <0.001 Fe, Pb, 0.0017 Pd, and 0.0001 Au; prepared by allowing elements to react at 1000 C for 6 hrs, then raising temperature to 1200 C for 1 hr to melt sample; cool to room temperature overnight, melted, broken into fragments, annealed at 500 C for 7 days and slowly cooled to room temperature for 7 days; density = 750 lb ft ⁻³ .

DATA TABLE NO. 233 SPECIFIC HEAT OF PLATINUM TELLURIDE PtTe

[Temperature, T, K; Specific Heat, C_p , Cal g⁻¹K⁻¹]

T	C_p	T	C_p
CURVE I (cont.)			
Series I		Series II	
67.93	2.107 x 10 ⁻²	4.92	5.888 x 10 ⁻⁵
73.71	2.262	5.83	9.306
81.17	2.445	6.78	1.518 x 10 ⁻⁴
88.74	2.606	7.76	2.386
96.25	2.731	7.67	2.355*
103.91	2.843*	8.73	3.650
111.67	2.946	9.84	5.426
119.76	3.034*	10.83	6.938
128.22	3.116	11.55	8.853
136.77	3.188*	13.19	1.155 x 10 ⁻³
142.66	3.233	14.46	1.467
151.34	3.284*	15.76	1.810
160.22	3.339*	17.12	2.197
169.23	3.379	18.64	2.665
178.35	3.419*	20.32	3.201
187.73	3.458*	22.16	3.827
197.16	3.490	24.14	4.534
206.61	3.518*		
216.02	3.541*		
225.33	3.563		
234.50	3.587*		
243.63	3.610*		
252.67	3.621		
261.16	3.645*		
Series III			
261.12	3.633 x 10 ^{-2*}	259.71	3.638 x 10 ^{-2*}
270.18	3.651*	268.84	3.651*
279.15	3.665	277.99	3.665*
		287.14	3.680*
		296.08	3.696*
		304.91	3.710*
		313.80	3.714
		322.95	3.721*
		332.36	3.735*
		340.92	3.749*
		347.07	3.755
Series IV			

*Not shown on plot

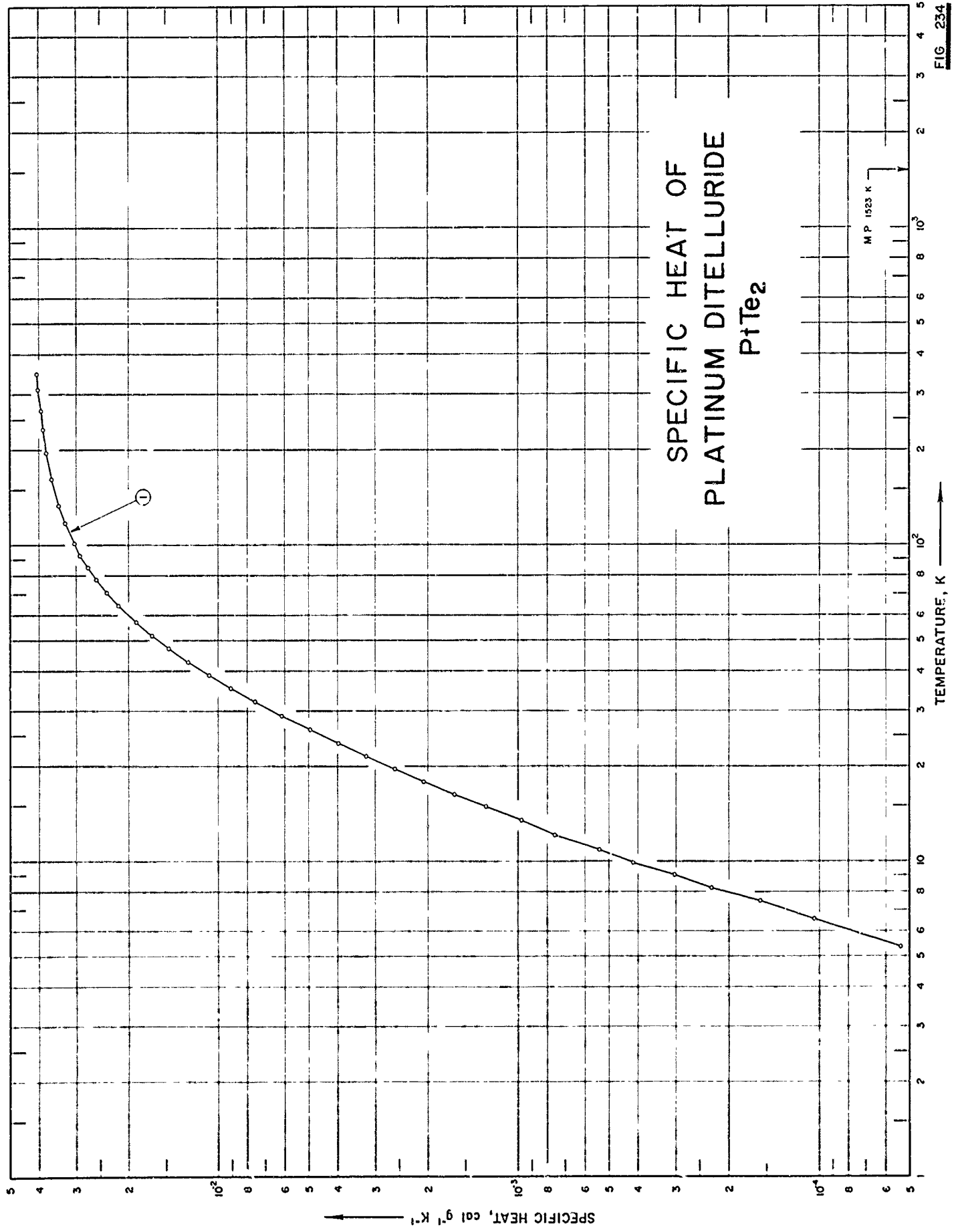
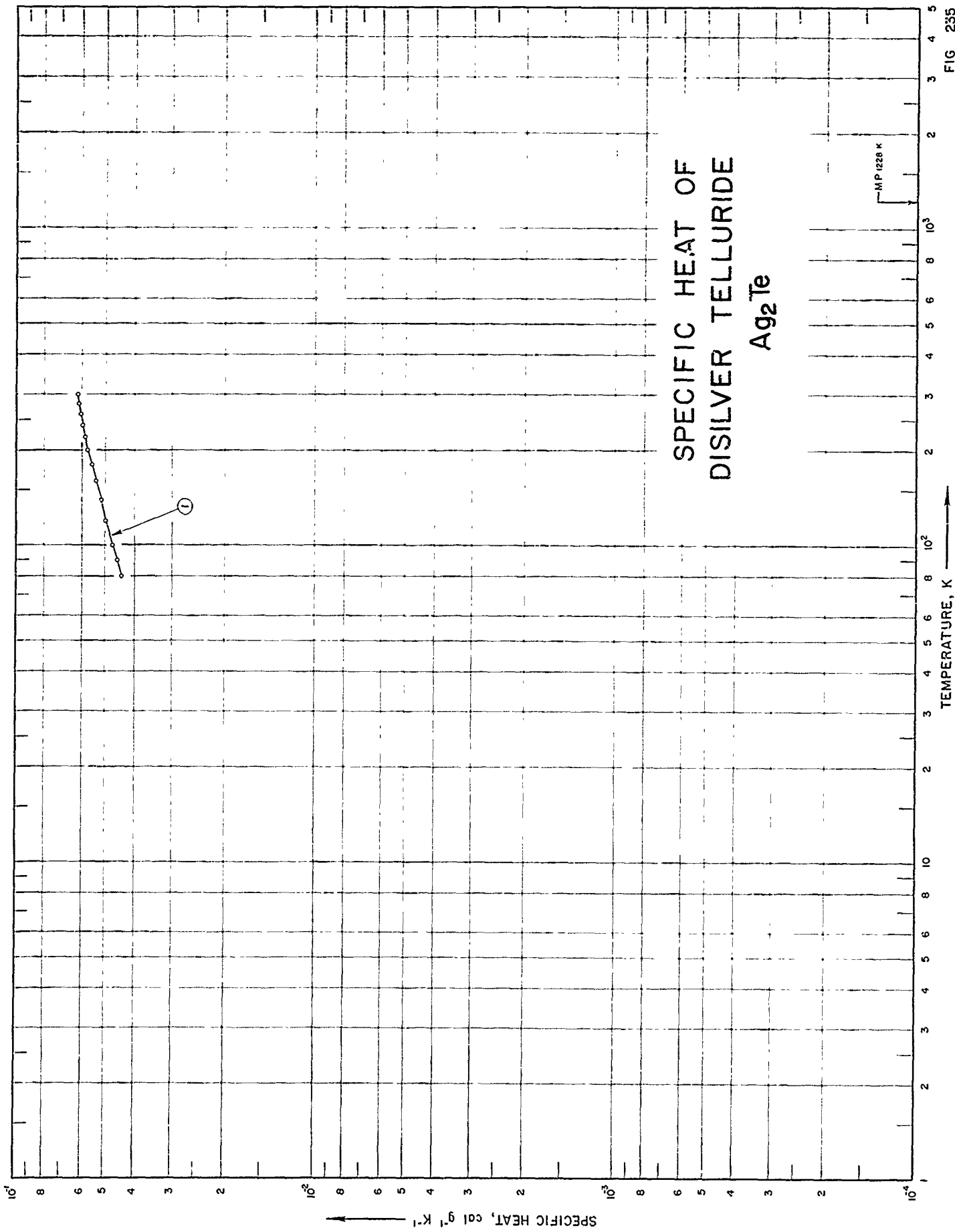

FIG 234

SPECIFICATION TABLE NO. 234 SPECIFIC HEAT OF PLATINUM DITELLURIDE PtTe₂

[For Data Reported in Figure and Table No. 234]

Curve No.	Ref. No.	Year	Temp. Range, K	Reported Error, %	Name and Specimen Designation	Composition (weight percent), Specifications and Remarks
1	224	1961	5-347	~0.1		High purity; platinum impurities: <0.001 Fe, Pb, 0.0007 Pd, 0.0001 Au, 0.009 volatile materials; prepared by reacting the elements at 1000 C for 5 hrs, annealed at 500 C for 7 days and cooled to room temperature for 7 days.



SPECIFICATION TABLE NO. 235 SPECIFIC HEAT OF SILVER TELLURIDE Ag_2Te

[For Data Reported in Figure and Table No. 235]

Curve No.	Ref. No.	Year	Temp. Range, K	Reported Error, %	Name and Specimen Designation	Composition (weight percent), Specifications and Remarks
1	160	1959	80-300	3-7		Polycrystalline.

DATA TABLE NO. 235 SPECIFIC HEAT OF DISILVER TELLURIDE Ag_2Te
[Temperature, T, K; Specific Heat, Cp, Cal $\text{g}^{-1}\text{K}^{-1}$]

T	Cp
<u>CURVE 1</u>	
80	4.41×10^{-2}
90	4.59
100	4.71
120	4.95
140	5.17
160	5.38
180	5.56
200	5.73
220	5.87
240	5.96
260	6.05
280	6.12
300	6.18

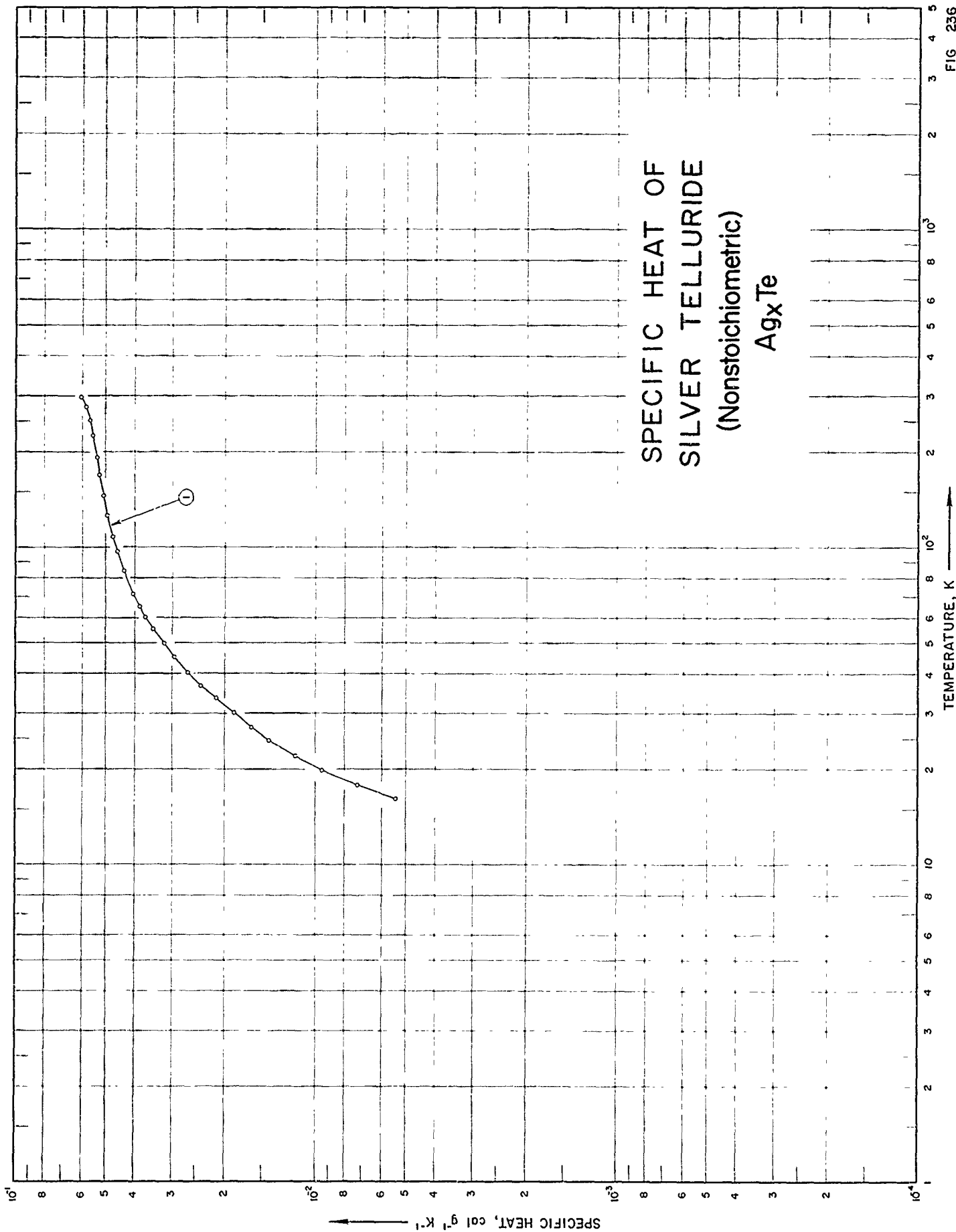

FIG 236

SPECIFICATION TABLE NO. 236 SPECIFIC HEAT OF SILVER TELLURIDE (nonstoichiometric) Ag_xTe

[For Data Reported in Figure and Table No. 236]

Curve No.	Ref. No.	Year	Temp. Range, K	Reported Error, %	Name and Specimen Designation	Composition (weight percent), Specifications and Remarks
1	225	1962	16-296			99.99 $Ag_{1.83}Te$; crushed under argon pressure.

DATA TABLE NO. 236 SPECIFIC HEAT OF SILVER TELLURIDE Ag_xTe (nonstoichiometric)
 [Temperature, T, K; Specific Heat, C_p , Cal $\text{g}^{-1}\text{K}^{-1}$]

T	C_p
CURVE 1	
16.16	5.391×10^{-3}
17.91	7.268
19.90	9.539
22.10	1.169×10^{-2}
24.65	1.423
27.37	1.632
30.25	1.856
33.50	2.135
36.82	2.408
40.44	2.653
45.36	2.950
50.09	3.192
55.49	3.467
60.59	3.683
65.62	3.943
71.65	4.040
84.83	4.367
97.60	4.591
109.38	4.733
126.51	4.945
145.70	5.094
154.12	5.166*
161.87	5.197*
170.15	5.269
185.28	5.348*
192.59	5.369
200.58	5.418*
207.64	5.448*
214.12	5.490*
220.67	5.518
226.05	5.542*
233.15	5.569*
244.47	5.624*
245.72	5.606*
251.79	5.645
257.70	5.690*
269.38	5.802*
277.27	5.839
283.34	5.908*
289.54	5.966*
296.16	6.033

* Not shown on plot

SPECIFIC HEAT OF CADMIUM DIBROMIDE CdBr2

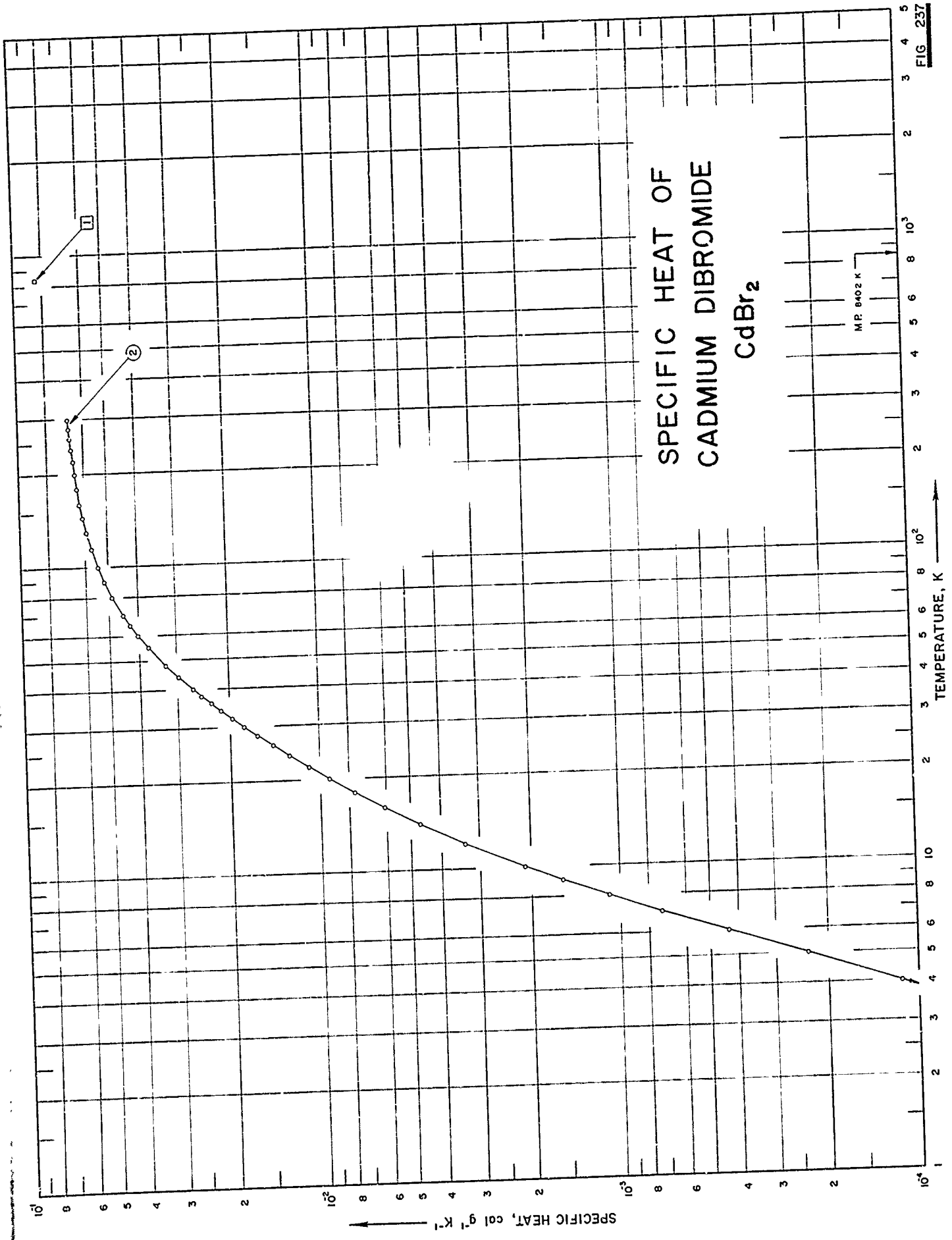

1

2

SPECIFICATION TABLE NO. 237 SPECIFIC HEAT OF CADMIUM DIBROMIDE CdBr_2

[For Data Reported in Figure and Table No. 237]

Curve No.	Ref. No.	Year	Temp. Range, K	Reported Error, %	Name and Specimen Designation	Composition (weight percent), Specifications and Remarks
1	242	1961	341.2			
2	312	1960	2-300	< 1.0		

DATA TABLE NO. 237 SPECIFIC HEAT OF CADMIUM DIBROMIDE CdBr_2 [Temperature, T, K; Specific Heat, C_p , Cal $\text{g}^{-1}\text{K}^{-1}$]

T	C_p	
	CURVE 1	CURVE 2 (cont.)
841.2	8.38×10^{-2}	5.632×10^{-2}
	CURVE 2	
2.00	1.397×10^{-5} *	5.713
3.00	4.706*	5.790*
4.00	1.147×10^{-4}	5.864*
5.00	2.353	5.930
6.00	4.338	5.992*
7.00	7.279	6.047*
8.00	1.096×10^{-3}	6.099
9.00	1.551	6.147*
10.00	2.081	6.191*
12.00	3.309	6.228
14.00	4.669	6.261*
16.00	6.139	6.290*
18.00	7.720	6.312*
20.00	9.338	6.334
22.00	1.099×10^{-2}	6.360*
24.00	1.272	6.378*
26.00	1.448	6.397*
28.00	1.625	6.415
30.00	1.801	6.433*
32.00	1.978	6.455*
34.00	2.151	6.470*
36.00	2.331	6.489
38.00	2.504	6.507*
40.00	2.665	6.525*
42.00	2.823*	6.540*
44.00	2.974	6.558
46.00	3.128*	6.573*
48.00	3.276	6.588*
50.00	3.419*	6.606*
55.00	3.746	6.621
60.00	4.036	6.636*
65.00	4.290	6.654*
70.00	4.514	6.669*
75.00	4.720*	6.683
80.00	4.900	6.702*
85.00	5.062*	6.713*
90.00	5.202	6.727*
95.00	5.327*	6.735*
100.00	5.437	6.739
105.00	5.540*	

* Not shown on plot

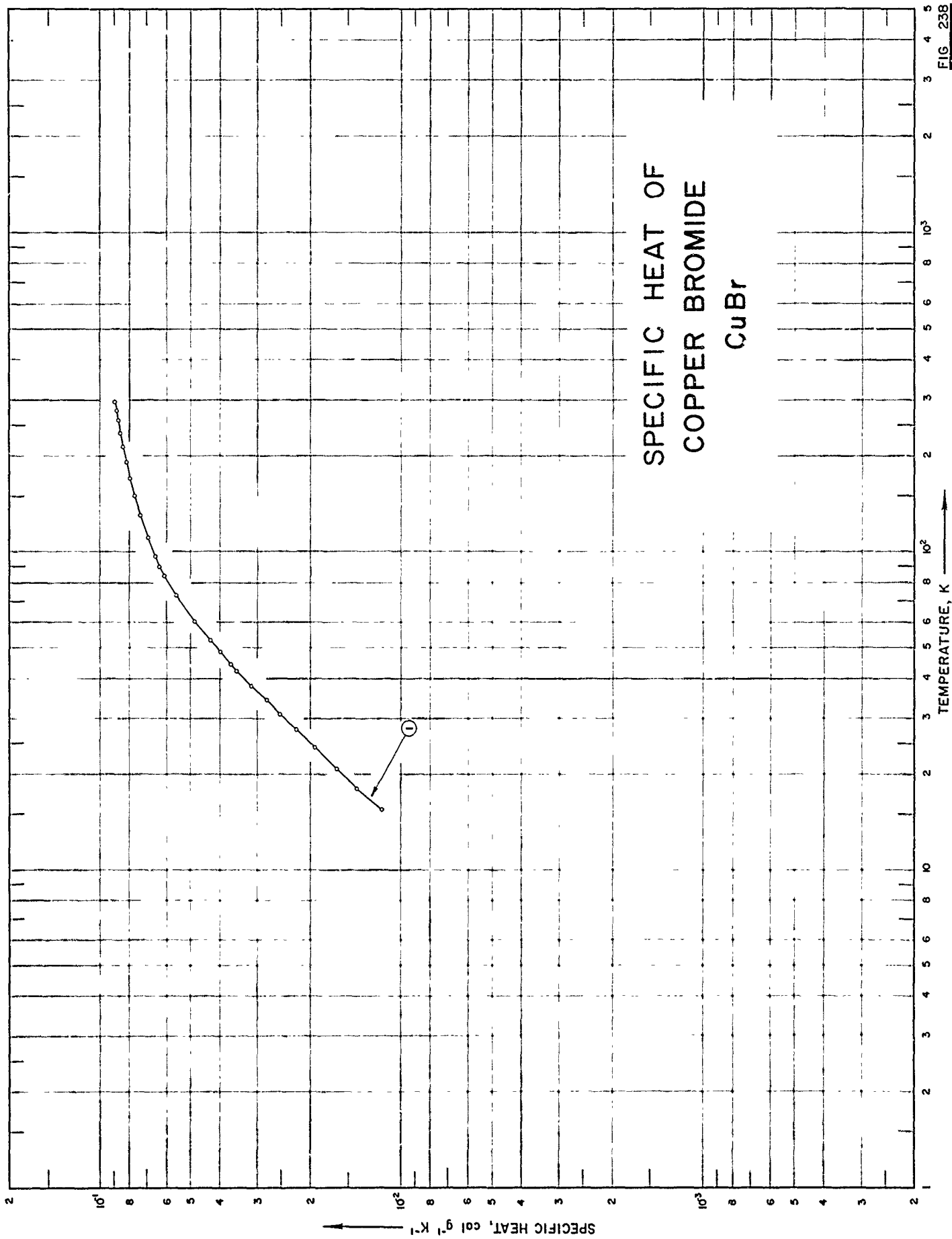

FIG. 238

SPECIFICATION TABLE NO. 238 SPECIFIC HEAT OF COPPER BROMIDE CuBr

[For Data Reported in Figure and Table No. 238]

Curve No.	Ref. No.	Year	Temp. Range K	Reported Error, %	Name and Specime. Designation	Composition (weight percent), Specifications and Remarks
1	313	1952	16-296			> 99.92 CuBr.

DATA TABLE NO. 238 SPECIFIC HEAT OF COPPER BROMIDE CuBr

[Temperature, T, K; Specific Heat, Cp, Cal g⁻¹K⁻¹]

T	Cp
15.51	1.175 x 10 ⁻²
18.09	1.413
20.78	1.654
24.25	1.958
27.71	2.262
30.89	2.555
34.29	2.836
37.90	3.187
42.47	3.570
44.45	3.725
48.54	4.046
52.96	4.377
54.34	4.525*
60.35	4.949
66.11	5.327*
73.09	5.685
78.58	5.988*
84.00	6.211
84.73	6.278*
88.87	6.453
96.94	6.663
104.44	6.869*
112.43	7.067
131.67	7.297*
131.27	7.485
141.41	7.660
150.84	7.820
189.92	7.939*
170.11	8.071
180.57	8.176*
192.01	8.322
203.50	8.399*
214.73	8.518
225.10	8.594*
236.25	8.713
247.46	8.769*
258.27	8.866
268.22	8.894*
277.77	8.971
286.91	9.076*
295.83	9.146

* Not shown on plot

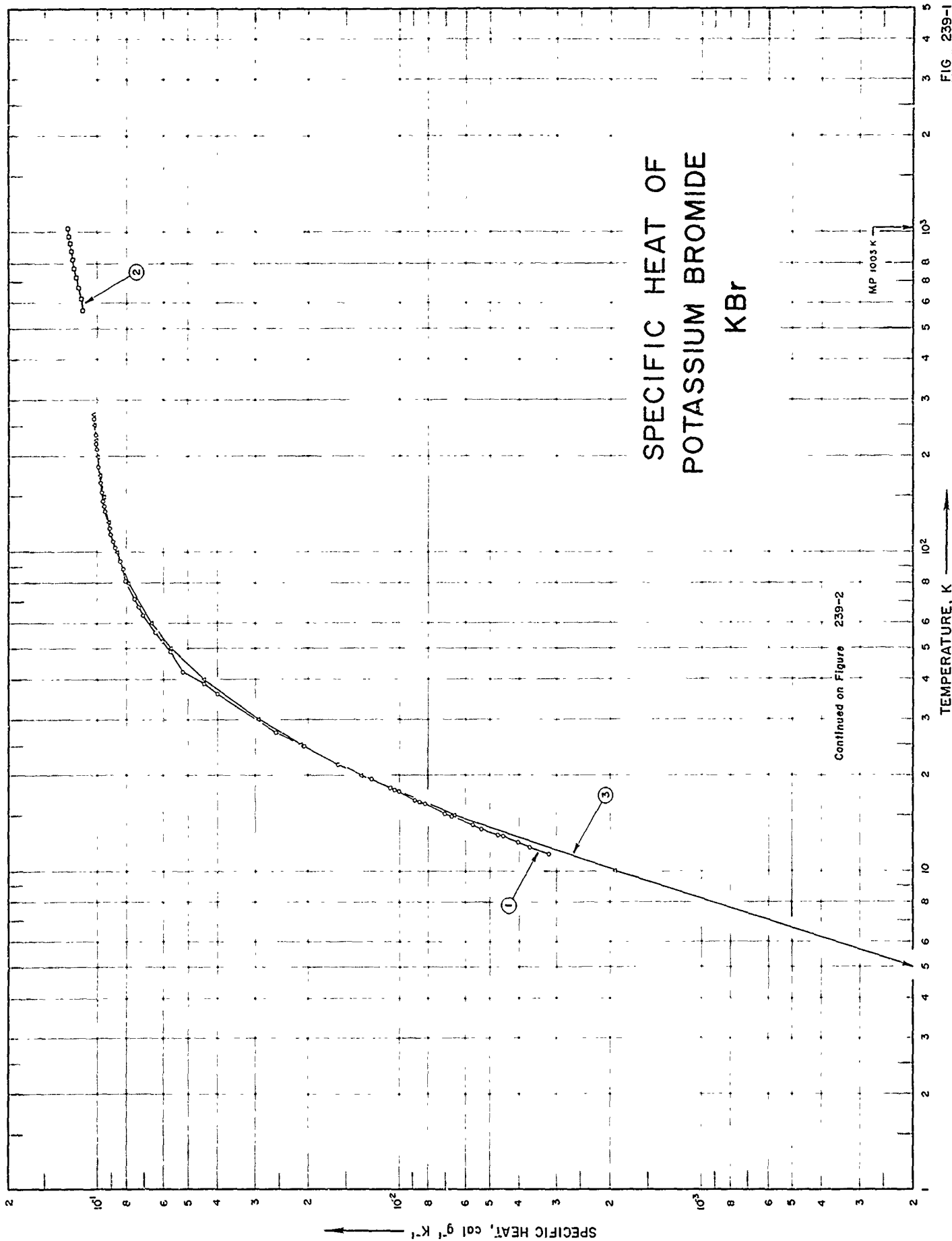

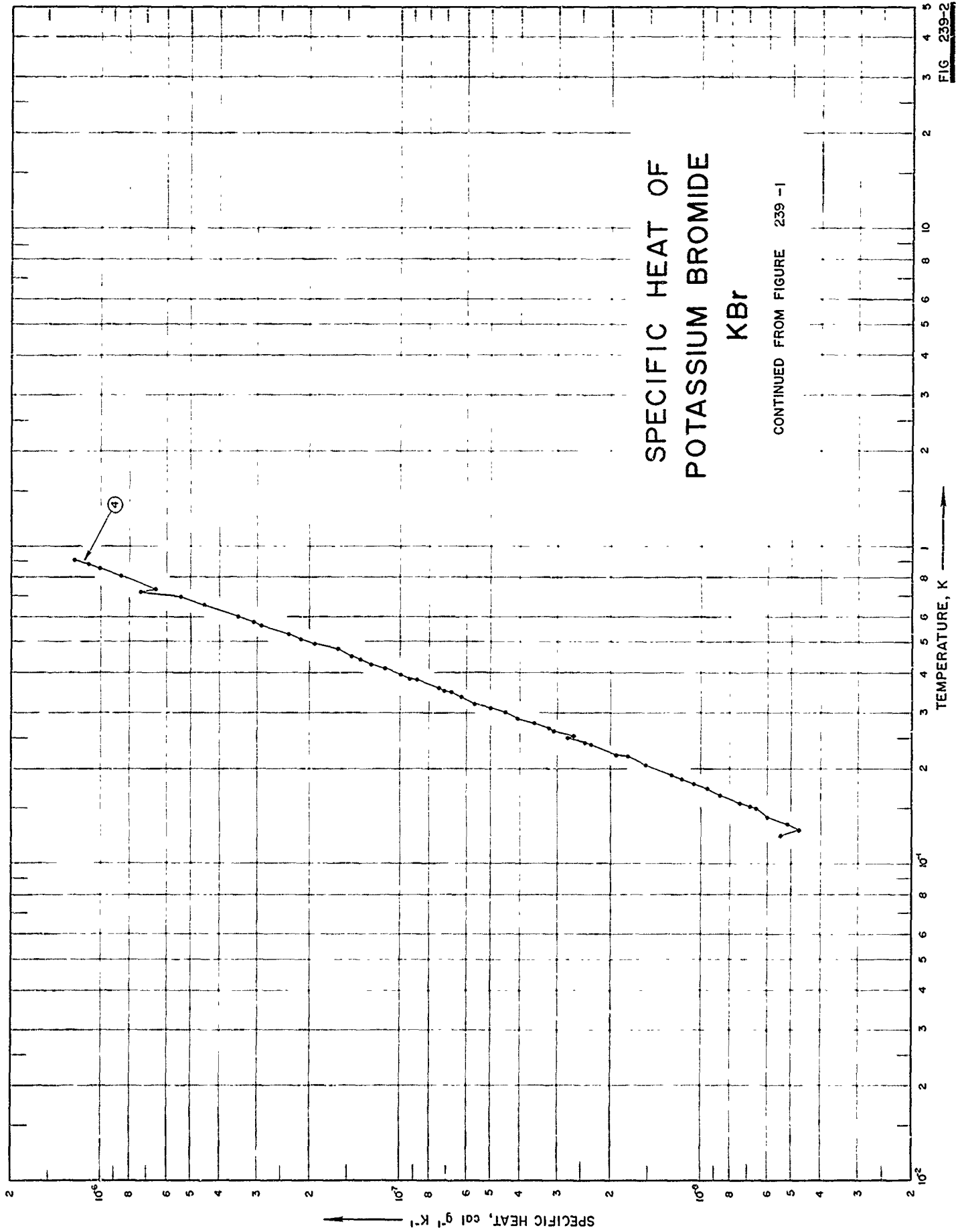

SPECIFICATION TABLE NO. 239 SPECIFIC HEAT OF POTASSIUM BROMIDE KBr

[For Data Reported in Figure and Table No. 239]

Curve No.	Ref. No.	Year	Temp. Range, K	Reported Error, %	Name and Specimen Designation	Composition (weight percent). Specifications and Remarks
1	243	1949	11-270			Sample supplied by the Harshaw Chem. Co.; measured under dry helium gas.
2	244	1953	573-1003	0.1-0.2		High purity, optical quality; sample supplied by the Harshaw Chem. Co.; measured under helium atmosphere.
3	245	1957	3-270	0.2-2		Very small traces of Co, Cu, and Mn; single crystal; sample supplied by the Harshaw Chem. Co.
4	314	1963	0.1-0.9			

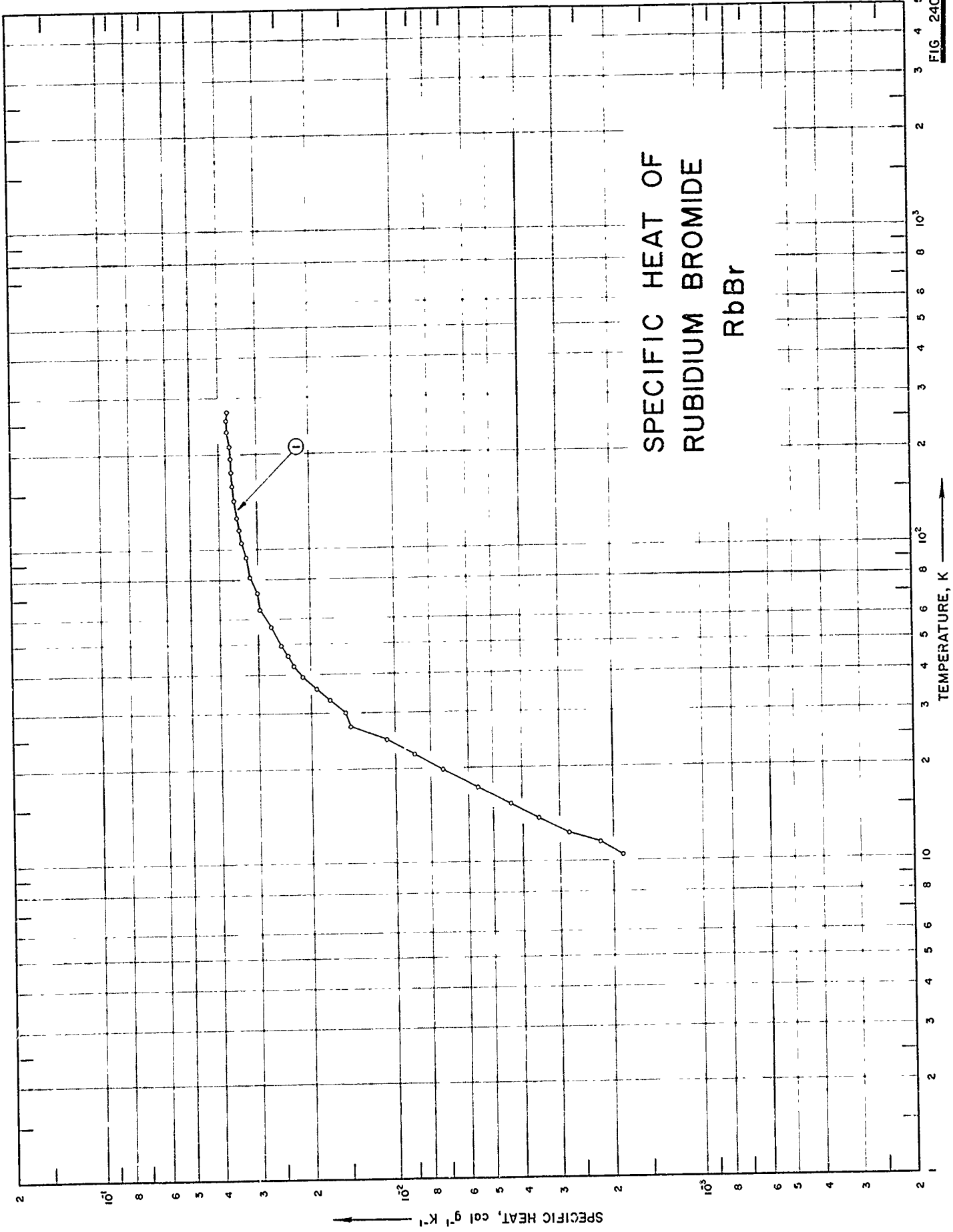

SPECIFIC HEAT OF
RUBIDIUM BROMIDE
RbBr

SPECIFICATION TABLE NO. 240 SPECIFIC HEAT OF RUBIDIUM BROMIDE RbBr

[For Data Reported in Figure and Table No. 240]

Curve No.	Ref. No.	Year	Temp. Range, K	Reported Error, %	Name and Specimen Designation	Composition (weight percent), Specifications and Remarks
1	243	1949	10-273			

DATA TABLE NO. 240 SPECIFIC HEAT OF RUBIDIUM BROMIDE RbBr

[Temperature, T, K; Specific Heat, Cp, Cal g⁻¹K⁻¹]

T	Cp	T	Cp
CURVE 1		CURVE I (cont.)	
10.5	1.88x10 ⁻³	187.5	3.70x10 ^{-2*}
11.6	2.24	193.3	3.67
12.4	2.84	199.2	3.73*
13.8	3.57	200.1	3.73*
15.4	4.42	206.1	3.75*
17.4	5.69	212.2	3.75
19.8	7.38	217.9	3.76*
22.2	9.20	223.7	3.76*
24.8	1.13x10 ⁻²	229.6	3.76*
27.3	1.52	235.9	3.78
30.3	1.55	242.4	3.78*
33.2	1.75	249.2	3.79*
36.2	1.94	256.5	3.81
39.4	2.17	264.6	3.79*
42.8	2.31	272.7	3.78
46.2	2.44		
49.6	2.58		
52.8	2.70*		
56.7	2.79		
60.5	2.89*		
64.5	2.96		
68.5	3.03*		
72.7	3.09		
76.9	3.15*		
81.5	3.21		
86.5	3.24*		
94.5	3.31		
99.9	3.38*		
105.8	3.41		
110.6	3.45*		
116.0	3.48		
121.4	3.52*		
126.8	3.54		
132.2	3.56*		
137.6	3.58*		
143.1	3.61		
148.4	3.62*		
153.8	3.63*		
159.3	3.65		
164.8	3.67*		
170.5	3.67*		
176.0	3.68		
181.7	3.69*		

* Not shown on plot

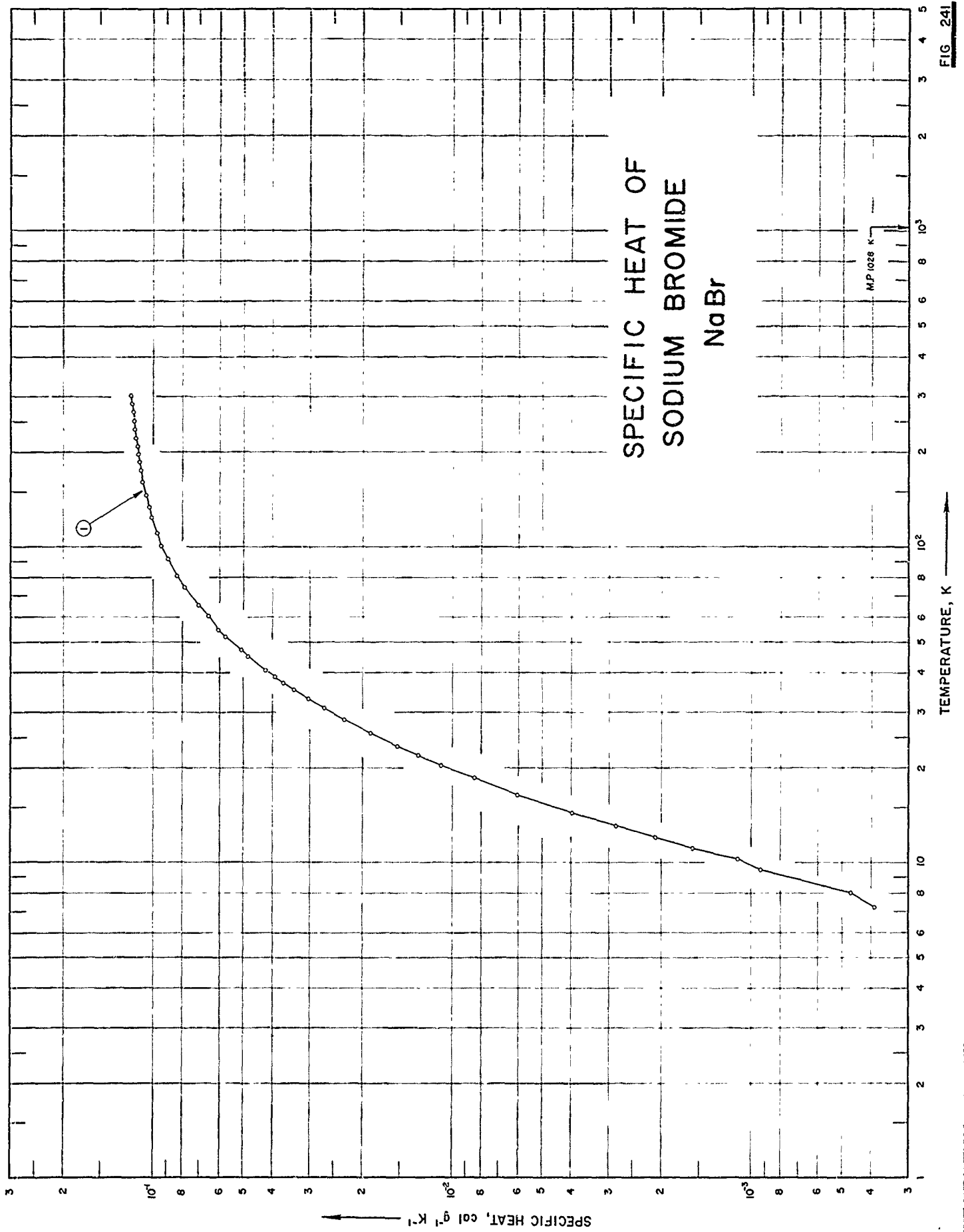

SPECIFICATION TABLE NO. 241 SPECIFIC HEAT OF SODIUM BROMIDE NaBr

[For Data Reported in Figure and Table No. 241 J]

Curve No.	Ref. No.	Year	Temp. Range, K	Reported Error, %	Name and Specimen Designation	Composition (weight percent), Specifications and Remarks
1	246	1964	7-302	0.3		> 99.979 NaBr, < 0.02 K, 0.0001-0.001 Ca and Mg; crystalline structure; reagent grade product recrystallized from water and dried overnight at 600 C.

DATA TABLE NO. 241 SPECIFIC HEAT OF SODIUM BROMIDE NaBr

[Temperature, T, K; Specific Heat, Cp, Cal g⁻¹K⁻¹]

T	Cp	CURVE 1		T	Cp	CURVE 1 (cont.)		T	Cp
		Cp	T			Cp	T		
7.21	3.800 x 10 ⁻⁴	102.00	9.418 x 10 ⁻²	246.35	1.163 x 10 ⁻¹ *	246.35	1.163 x 10 ⁻¹ *	246.35	1.163 x 10 ⁻¹ *
8.00	4.675	104.71	9.512*	250.10	1.165	250.10	1.165	250.10	1.165
9.45	9.320	107.95	9.631*	253.83	1.169*	253.83	1.169*	253.83	1.169*
10.25	1.118 x 10 ⁻³	111.50	9.751	257.55	1.171*	257.55	1.171*	257.55	1.171*
11.11	1.575	114.73	9.861*	261.26	1.173*	261.26	1.173*	261.26	1.173*
12.03	2.099	117.91	9.959*	264.94	1.175*	264.94	1.175*	264.94	1.175*
13.09	2.848	121.05	1.005 x 10 ⁻¹ *	268.61	1.177	268.61	1.177	268.61	1.177
14.45	3.994	124.14	1.014	271.95	1.179*	271.95	1.179*	271.95	1.179*
16.48	6.016	127.20	1.022*	275.63	1.186*	275.63	1.186*	275.63	1.186*
18.62	8.436	130.47	1.030*	279.40	1.183*	279.40	1.183*	279.40	1.183*
20.34	1.092 x 10 ⁻²	134.01	1.038	284.23	1.186	284.23	1.186	284.23	1.186
21.86	1.397	137.13	1.045*	287.29	1.187*	287.29	1.187*	287.29	1.187*
23.36	1.523	140.59	1.053*	292.89	1.190*	292.89	1.190*	292.89	1.190*
25.70	1.877	144.01	1.059*	298.22	1.194*	298.22	1.194*	298.22	1.194*
28.48	2.309	147.41	1.066	301.63	1.196	301.63	1.196	301.63	1.196
30.82	2.687	150.77	1.071*						
33.03	3.048	154.12	1.076*						
35.25	3.293	157.60	1.083*						
37.07	3.682	161.21	1.087						
38.80	3.938	164.80	1.093*						
40.86	4.223	168.41	1.097*						
42.93	4.535*	171.18	1.101*						
45.06	4.824	171.99	1.103*						
47.27	5.115	175.50	1.106						
49.63	5.431*	178.98	1.111*						
52.15	5.742	179.13	1.111*						
54.88	6.059	182.54	1.114*						
57.75	6.378*	186.23	1.119						
58.67	6.476*	189.93	1.122*						
60.50	6.558	193.60	1.127*						
62.87	6.599*	197.23	1.130						
63.30	6.953*	200.88	1.133*						
65.72	7.175	204.51	1.137*						
68.69	7.431*	208.07	1.139						
71.68	7.675*	211.61	1.142*						
74.55	7.893	215.14	1.145*						
77.74	8.008*	218.65	1.148*						
81.23	8.366	222.14	1.150						
84.76	8.596*	225.61	1.151*						
88.39	8.806*	229.07	1.154*						
91.92	8.980	232.52	1.156*						
95.32	9.140*	235.95	1.158						
98.64	9.281*	239.37	1.159*						
		242.77	1.161*						

* Not shown on plot

FIG. 242

SPECIFIC HEAT OF STRONTIUM BROMIDE SrBr

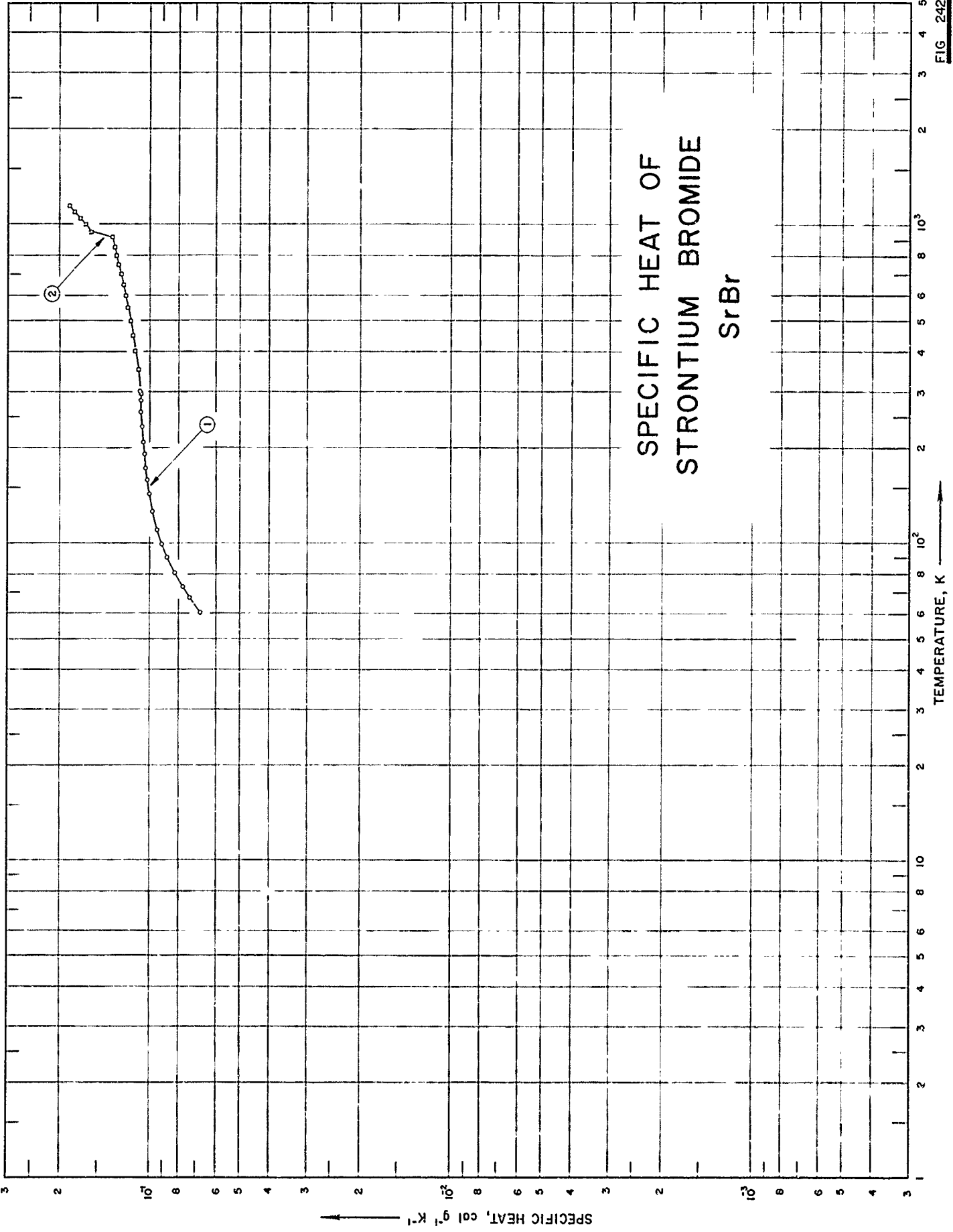

SPECIFIC HEAT, cal g⁻¹ K⁻¹

TEMPERATURE, K

SPECIFICATION TABLE NO. 242 SPECIFIC HEAT OF STRONTIUM BROMIDE SrBr₂

[For Data Reported in Figure and Table No. 242]

Curve No.	Ref. No.	Year	Temp. Range, K	Reported Error, %	Name and Specimen Designation	Composition (weight percent), Specifications and Remarks
1	315	1962	60-302			0.1-0.01 Ca; heated 4 hrs to 400-450 C.
2	315	1962	298-1150			Same as above.

DATA TABLE NO. 242 SPECIFIC HEAT OF STRONTIUM BROMIDE SrBr

[Temperature, T, K; Specific Heat, Cp, Cal g⁻¹K⁻¹]

T	Cp	T	Cp
CURVE 1		CURVE 2	
CURVE 1 (cont.)		CURVE 2	
60.30	6.815 x 10 ⁻²	247.83	1.075 x 10 ^{-1*}
63.60	7.149*	253.50	1.075*
67.55	7.394	259.12	1.075
70.73	7.633*	264.70	1.075*
73.26	7.788	270.22	1.075*
77.57	8.087*	270.88	1.075*
80.92	8.266	275.70	1.074*
84.15	8.445*	281.12	1.074
87.25	8.607*	286.48	1.076*
90.28	8.798	297.07	1.076*
93.28	8.893*	301.86	1.076
96.21	9.025*		
99.52	9.162		
103.18	9.299*		
106.74	9.365*		
110.56	9.467	298.15	1.074 x 10 ⁻¹
112.93	9.556*	300.00	1.074*
117.82	9.646*	350.00	1.098
127.28	9.807	400.00	1.121
132.29	9.903*	450.00	1.144
137.73	9.992*	500.00	1.166
143.05	1.009 x 10 ⁻¹	550.00	1.188
148.24	1.016*	600.00	1.210
153.38	1.020*	650.00	1.232
158.44	1.024	700.00	1.254
163.43	1.029*	750.00	1.275
168.37	1.033*	800.00	1.297
173.28	1.035	850.00	1.319
178.47	1.035*	900.00	1.341*
183.38	1.020*	(s)916.00	1.348
183.91	1.039*	(t)916.00	1.341*
187.18	1.040*	950.00	1.570
192.48	1.047	1000.00	1.642
197.75	1.050*	1050.00	1.714
199.91	1.051*	1100.00	1.786
202.96	1.054*	1150.00	1.859
208.13	1.057		
213.25	1.059*		
218.34	1.061*		
223.38	1.063*		
228.38	1.066*		
233.74	1.068		
236.36	1.069*		
242.12	1.070*		

* Not shown on plot

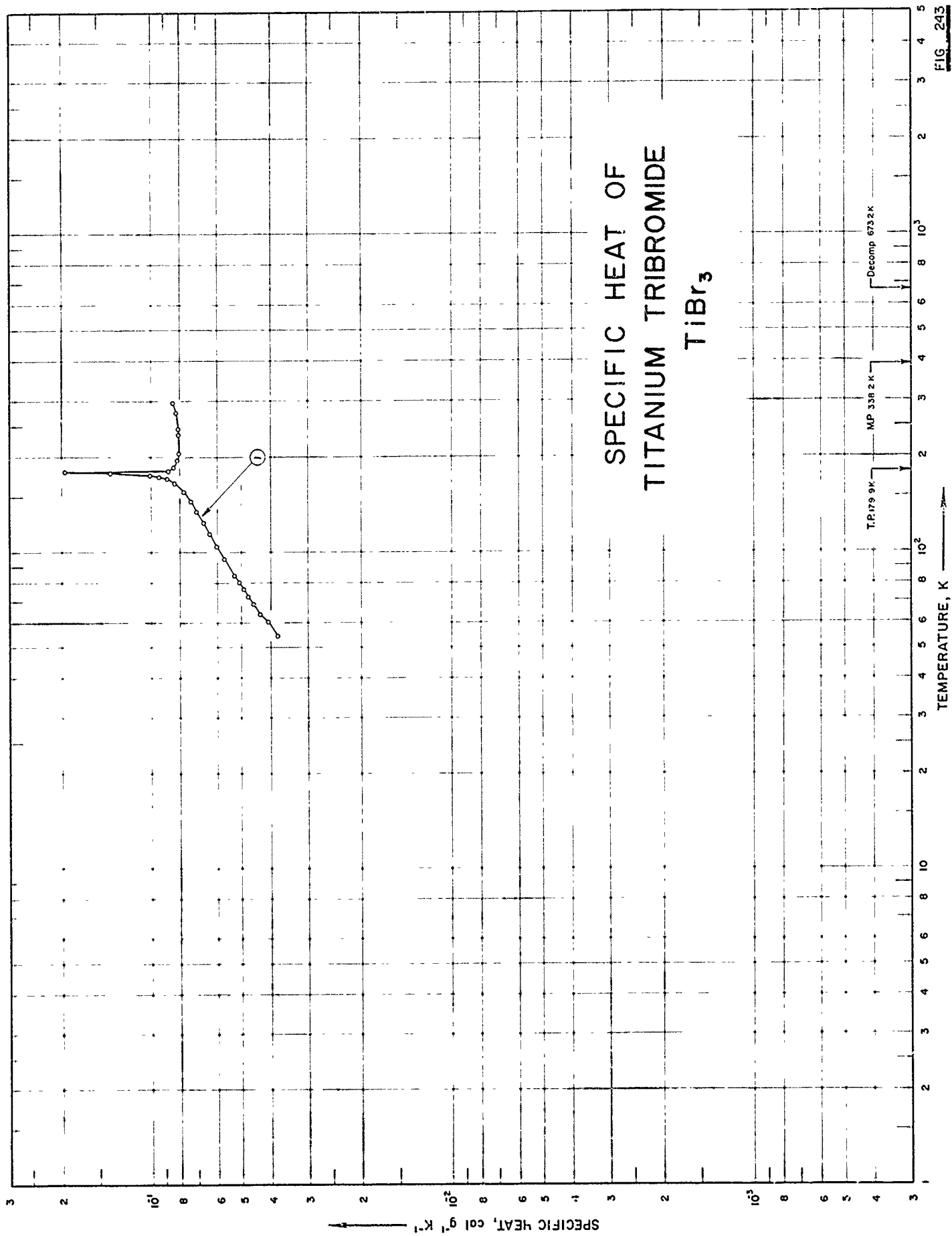

SPECIFICATION TABLE NC. 243 SPECIFIC HEAT OF TITANIUM TRIBROMIDE $TiBr_3$

[For Data Reported in Figure and Table No. 243]

Curve No.	Ref. No.	Year	Temp. Range, K	Reported Error, %	Name and Specimen Designation	Composition (weight percent), Specifications and Remarks
1	247	1961	55-298			83.18 Br (83.35 theo.) and 16.74 Ti (16.65 theo.).

DATA TABLE NO. 243 SPECIFIC HEAT OF TITANIUM TRIBROMIDE $TiBr_3$ [Temperature, T, K; Specific Heat, Cp, Cal g⁻¹K⁻¹]

T	Cp
	<u>CURVE 1</u>
54.63	3.793×10^{-2}
60.27	4.099
64.37	4.332
68.71	4.565
72.75	4.756
76.55	4.930
80.32	5.096
84.42	5.295
95.12	5.701
105.19	6.052
114.90	6.397
124.85	6.692
135.92	7.050
146.03	7.374
155.92	7.763
165.94	8.354
166.93	8.448*
170.68	8.861
173.82	9.400
175.82	1.018×10^{-1}
176.43	1.039*
178.47	1.373
180.02	1.952
181.77	8.771×10^{-2}
183.85	8.559*
186.20	8.427
187.62	8.392*
196.31	8.184
206.54	8.065
216.85	8.062*
226.44	8.058*
236.61	8.090
246.46	8.118
257.13	8.149*
266.85	8.187*
276.82	8.260
286.96	8.364*
297.88	8.462

* Not shown on plot

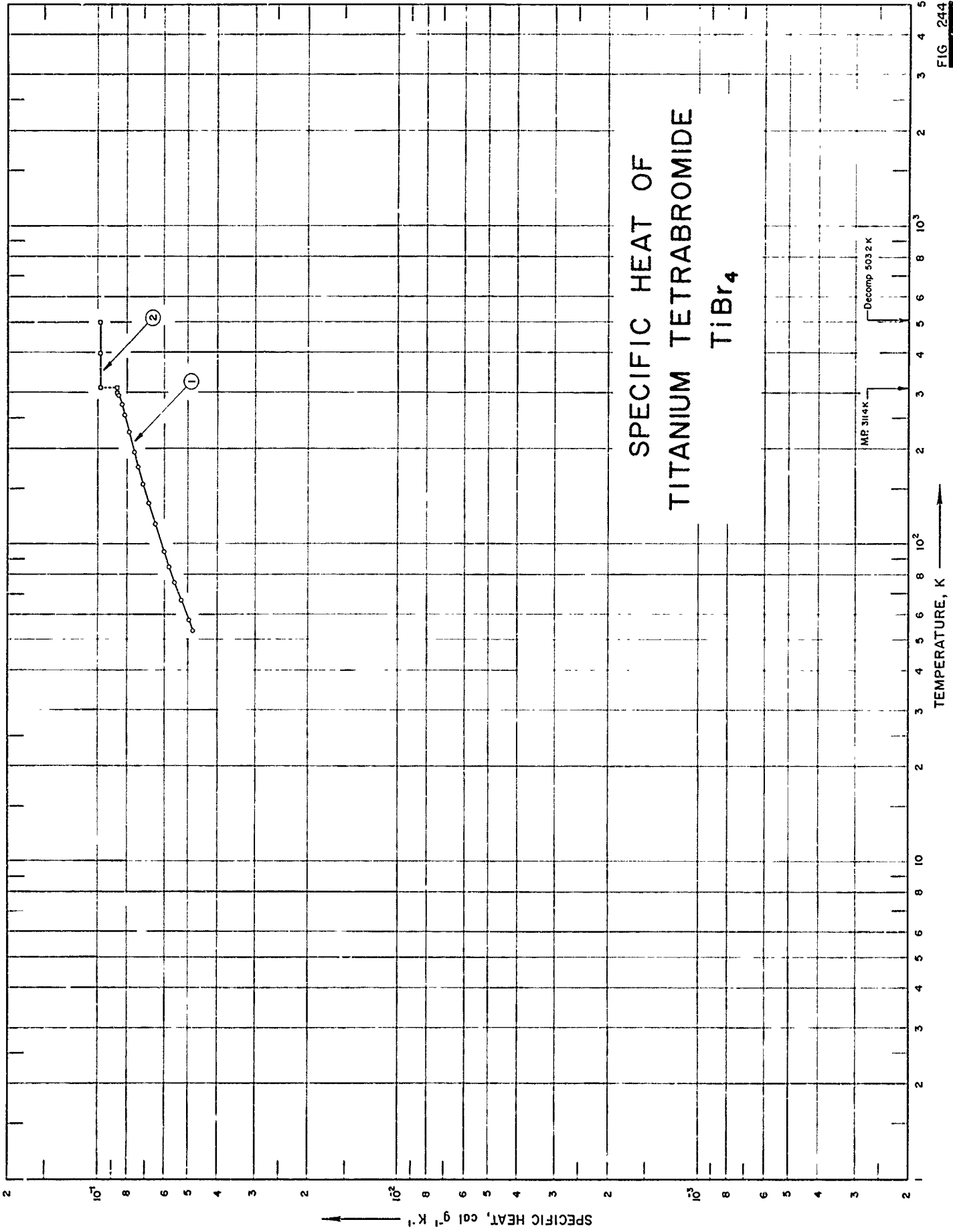

SPECIFICATION TABLE NO. 244 SPECIFIC HEAT OF TITANIUM TETRABROMIDE $TiBr_4$

[For Data Reported in Figure and Table No. 244]

Curve No.	Ref. No.	Year	Temp. Range, K	Reported Error, %	Name and Specimen Designation	Composition (weight percent), Specifications and Remarks
1		1961	54-296			
2	247	1961	298-500			99.998 $TiBr_4$; 86.88 Br (86.88 theo.) and 13.04 Ti (13.03 theo.).

DATA TABLE NO. 244 SPECIFIC HEAT OF TITANIUM TETRABROMIDE $TiBr_4$ [Temperature, T K; Specific Heat, Cp, Cal g⁻¹K⁻¹]

T	Cp
<u>CURVE 1</u>	
53.71	4.826×10^{-2}
58.09	4.971
62.69	5.134*
67.16	5.297
71.64	5.436*
76.27	5.575
81.04	5.719*
85.22	5.800
95.07	6.015
105.36	6.228*
117.34	6.456
125.54	6.603*
136.13	6.780
145.94	6.949*
155.55	7.101
165.96	7.223*
176.03	7.351
186.03	7.452*
195.84	7.574
206.30	7.694*
216.20	7.778*
226.91	7.882
236.13	7.974*
245.80	8.059*
256.26	8.156
266.49	8.246*
276.43	8.328
289.71	8.445*
296.34	8.551
<u>CURVE 2</u>	
298.15	8.624×10^{-2} *
300.00	8.624
(S) 311.40	8.624
(L) 311.40	9.875
400.00	9.875
500.00	9.875

* Not shown on plot

SPECIFIC HEAT OF BARIUM DICHLORIDE BaCl2

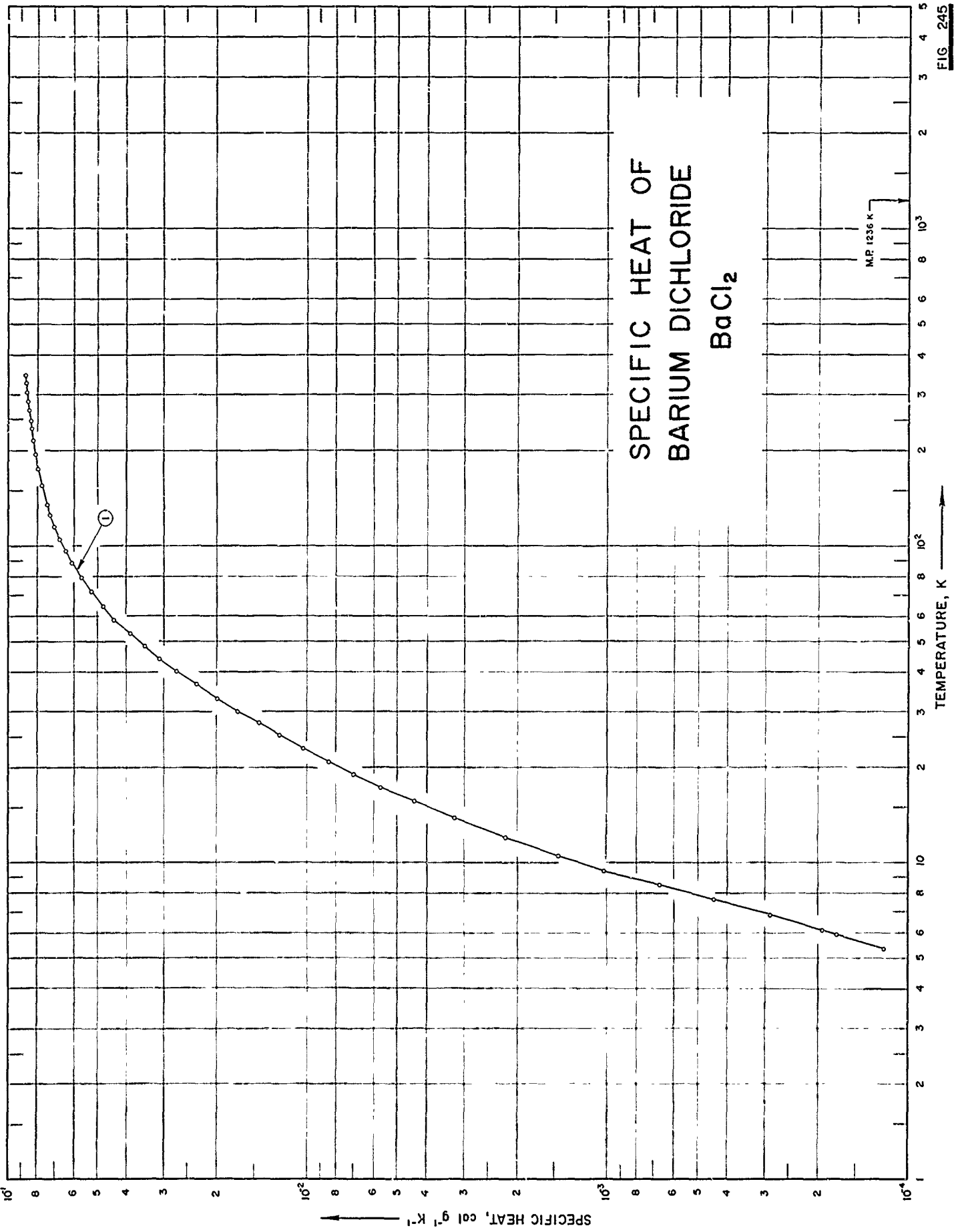

PRECEDING PAGE BLANK-NOT FILMED

SPECIFICATION TABLE NO. 245 SPECIFIC HEAT OF BARIUM DICHLORIDE BaCl₂

[For Data Reported in Figure and Table No. 245]

Curve No.	Ref. No.	Year	Temp. Range, K	Reported Error, %	Name and Specimen Designation	Composition (weight percent), Specifications and Remarks
1	317	1966	5-346	≤ 5.0		99.9 BaCl ₂ ; prepared by dehydrating reagent grade BaCl ₂ ·2H ₂ O in HCl atmosphere.

DATA TABLE NO. 245 SPECIFIC HEAT OF BARIUM DICHLORIDE BaCl₂[Temperature, T, K; Specific Heat, Cp, Cal g⁻¹K⁻¹]

T	Cp	T	Cp
CURVE 1		CURVE 1 (cont.)	
Series 1			
249.74	8.447 x 10 ⁻²	10.59	1.469 x 10 ⁻³
258.29	8.471*	12.15	2.180
268.31	8.519	13.94	3.246
277.74	8.543*	15.71	4.437
287.12	8.586	17.45	5.710
297.11	8.620*	19.09	7.001
307.69	8.663	20.87	8.490
318.23	8.687*	23.03	1.087 x 10 ⁻²
328.71	8.720	25.30	1.244
338.12	8.744*	27.59	1.460
346.44	8.759	30.13	1.706
		33.03	1.993
		36.56	2.346
		40.44	2.727
		44.36	3.101
		48.54	3.488
		53.29	3.900
		58.61	4.334
		64.90	4.801
		72.12	5.264
		79.66	5.681
Series 2			
75.18	5.431 x 10 ⁻⁵ *		
81.82	5.792*		
88.85	6.124		
96.98	6.431		
106.40	6.739		
116.41	7.013		
126.24	7.241		
135.97	7.434		
145.80	7.597*		
155.76	7.736		
165.86	7.856*		
176.12	7.957		
186.23	8.053		
196.21	8.125		
206.08	8.192		
215.85	8.259		
225.64	8.312*		
235.46	8.370		
245.20	8.413		
Series 3			
5.92	1.729 x 10 ⁻⁴		
5.36	1.201		
6.11	1.921		
6.87	2.881		
7.68	4.418		
8.50	6.723		
9.44	1.023 x 10 ⁻³		

* Not shown on plot

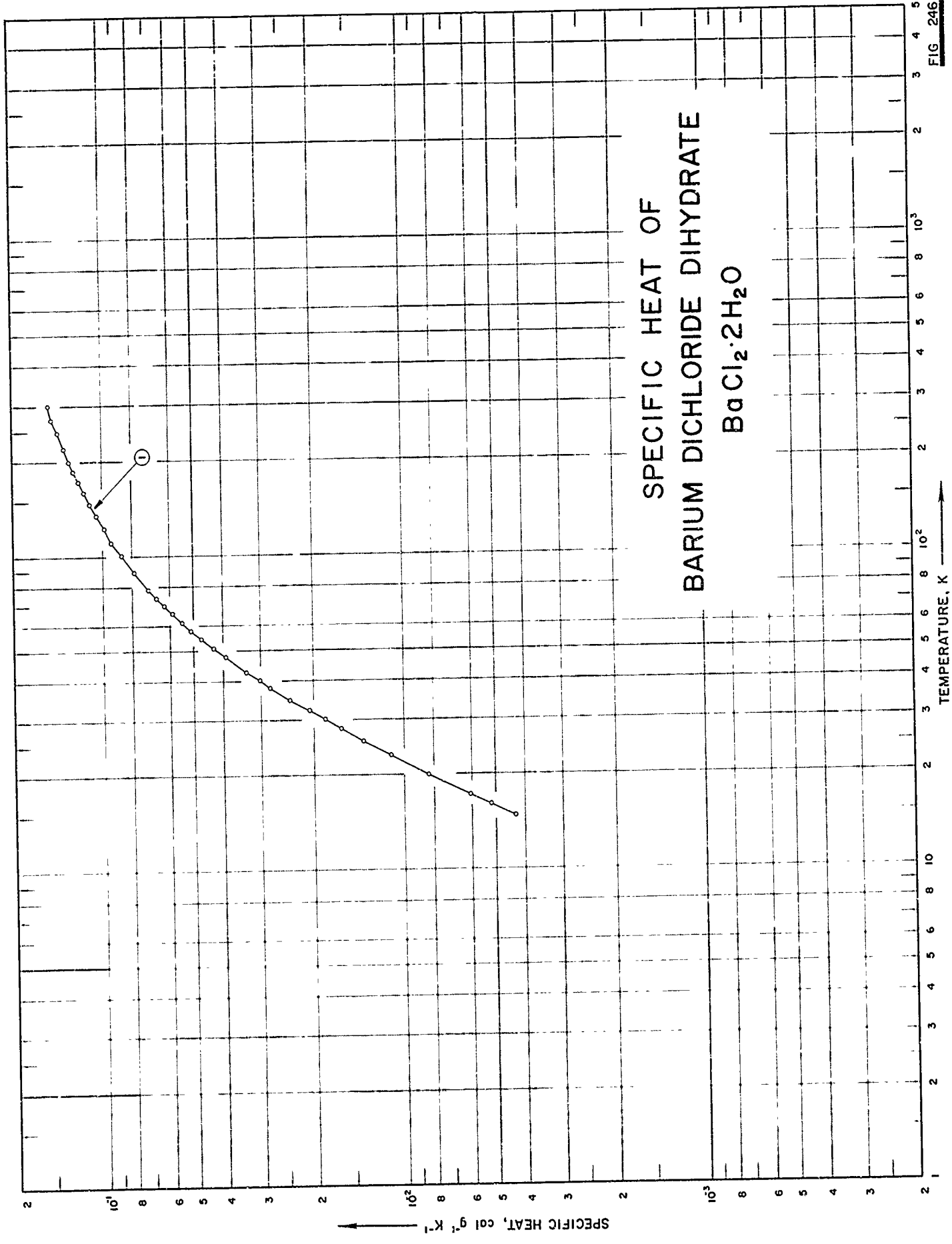

FIG 246

SPECIFICATION TABLE NO. 246 SPECIFIC HEAT OF BARIUM DICHLORIDE DIHYDRATE $\text{BaCl}_2 \cdot 2\text{H}_2\text{O}$

[For Data Reported in Figure and Table No. 246]

Curve No.	Ref. No.	Year	Temp. Range, K	Reported Error, %	Name and Specimen Designation	Composition (weight percent), Specifications and Remarks
1	318	1936	15-301			C.P. grade BaCl_2 was crystallized three times from redistilled water; dried at 165 K and rehydrated in a dessicator containing water to obtain the theoretical amount of water.

DATA TABLE NO. 246 SPECIFIC HEAT OF BARIUM DICHLORIDE DIHYDRATE BaCl₂ · 2H₂O[Temperature, T, K; Specific Heat, Cp, Cal g⁻¹K⁻¹]

T	CURVE 1		T	CURVE 1 (cont.)	
	Cp	10^{-3}		Cp	10^{-3}
14.87	4.339	10^{-3}	207.32	1.314	10^{-3}
16.18	5.198		214.06	1.333*	
17.24	6.099		221.02	1.349	
20.00	8.350		229.72	1.369*	
23.16	1.117	10^{-2}	236.41	1.383*	
25.69	1.375		244.76	1.415	
28.14	1.625		254.54	1.433*	
30.21	1.846		263.58	1.446*	
32.13	2.067		272.18	1.474	
34.87	2.411		281.17	1.493*	
37.98	2.791		287.97	1.500*	
40.45	3.025		297.07	1.518*	
42.91	3.381		301.28	1.520	
48.02	3.942				
51.15	4.326				
54.60	4.723				
58.06	5.120				
61.78	5.476				
66.12	5.914				
69.82	6.283				
70.78	6.377*				
73.92	6.676				
78.67	7.093				
83.68	7.494*				
89.08	7.900				
94.72	8.293				
100.61	8.681				
106.37	9.005*				
112.10	9.361				
117.92	9.631				
123.62	9.889				
129.49	1.021	10^{-4}			
135.64	1.056				
141.68	1.083*				
147.14	1.109				
153.76	1.132*				
160.01	1.155				
166.86	1.178*				
173.45	1.201				
180.25	1.226*				
187.15	1.254				
193.41	1.271*				
200.27	1.295				

* Not shown on plot

SPECIFIC HEAT OF
CADMIUM DICHLORIDE
 CdCl_2

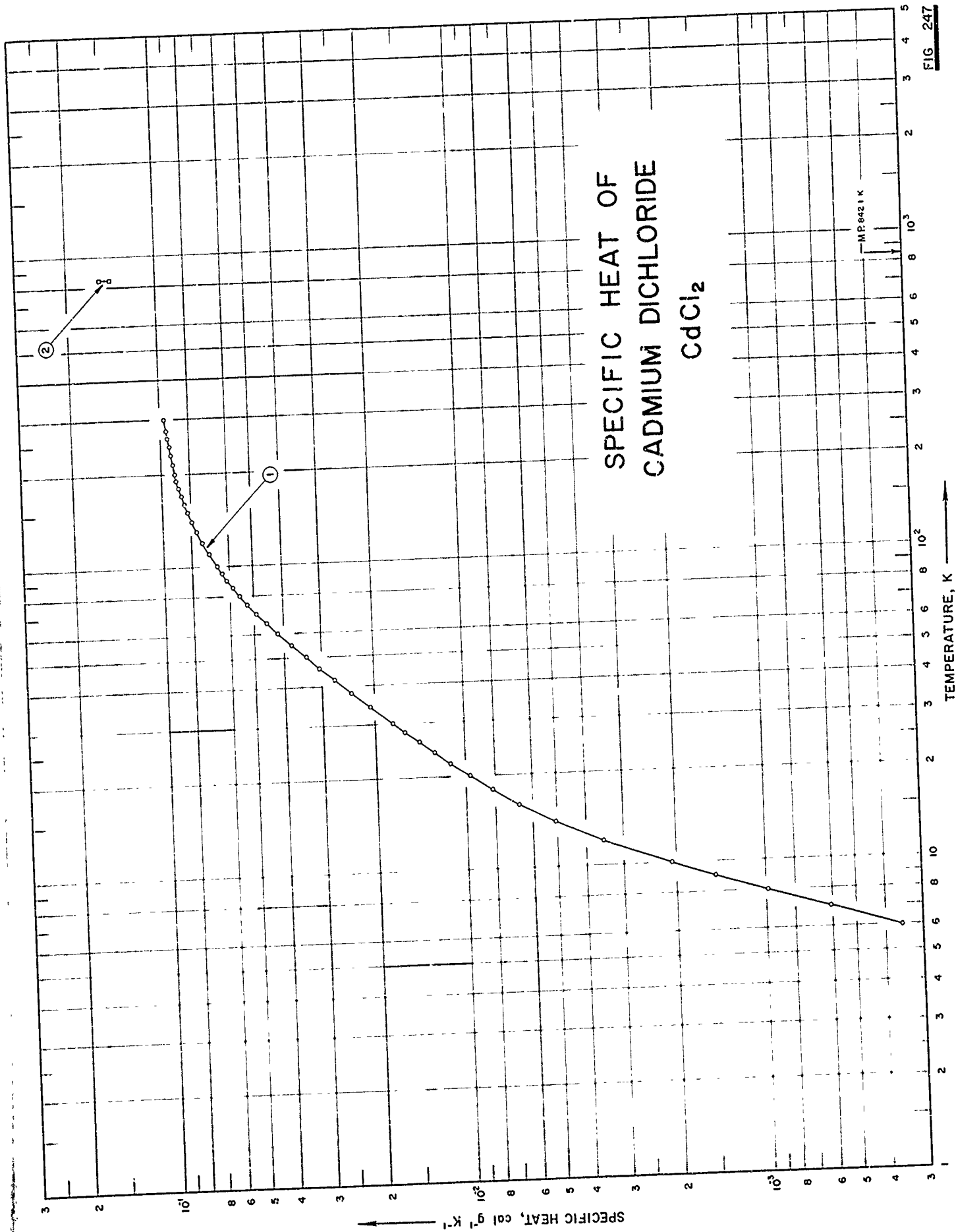

SPECIFICATION TABLE NO. 247 SPECIFIC HEAT OF CADMIUM DICHLORIDE CdCl_2

[For Data Reported in Figure and Table No. 247]

Curve No.	Ref. No.	Year	Temp. Range, K	Reported Error, %	Name and Specimen Designation	Composition (weight percent), Specifications and Remarks
1	248	1959	2-300	1.0		Purified
2	249	1960	842.1			

DATA TABLE NO. 247 SPECIFIC HEAT OF CADMIUM DICHLORIDE CdCl_2 [Temperature, T, K; Specific Heat, Cp, Cal $\text{g}^{-1}\text{K}^{-1}$]

T	Cp	T	Cp
	<u>CURVE 1</u>		<u>CURVE 1 (cont.)</u>
3	1.20×10^{-5}	135	7.95×10^{-2}
4	4.09	140	8.03
5	9.66	145	8.15*
6	1.94×10^{-4}	150	8.27
7	3.55	155	8.37*
8	6.11	160	8.47
9	1.49×10^{-3}	165	8.56*
10	2.08	170	8.65
12	3.51	175	8.72*
14	5.06	180	8.79
16	6.72	185	8.86*
18	8.24	190	8.92
20	9.77	195	8.97*
22	1.13×10^{-2}	200	9.02
24	1.28	205	9.07*
26	1.44	210	9.12*
28	1.60	215	9.17
30	1.76	220	9.21*
32	1.93*	225	9.25*
34	2.09	230	9.29
36	2.25*	235	9.32*
38	2.41	240	9.36*
40	2.57*	245	9.39
42	2.74	250	9.43*
44	2.90*	255	9.46*
46	3.07	260	9.49
48	3.24*	265	9.53*
50	3.40	270	9.55*
55	3.80	275	9.59
60	4.21	280	9.61*
65	4.59	285	9.65*
70	4.95	290	9.68*
75	5.31	295	9.71*
80	5.63	298.16	9.73*
85	5.93	300	9.74
90	6.20		
95	6.45		
100	6.67		
105	6.87*		
110	7.08		
115	7.26*		
120	7.44		
125	7.60*		
130	7.75		
		<u>CURVE 2</u>	
		(S) 842.1	1.55×10^{-1}
		(I) 842.1	1.43

* Not shown on plot

SPECIFIC HEAT OF CALCIUM DICHLORIDE CaCl_2

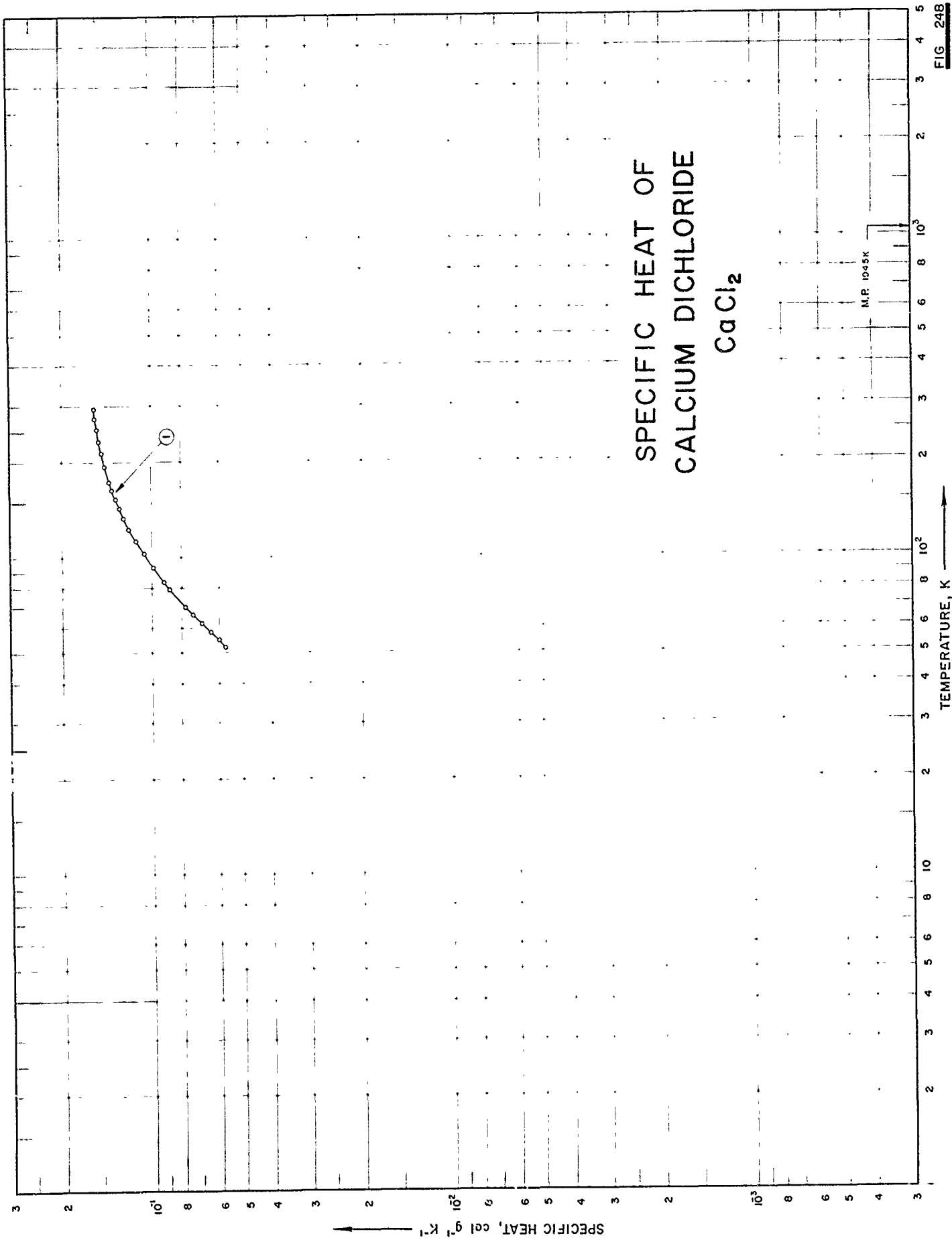

FIG. 248

SPECIFICATION TABLE NO. 248 SPECIFIC HEAT OF CALCIUM DICHLORIDE CaCl_2

[For Data Reported in Figure and Table No. 248]

Curc No.	Ref. No.	Year	Temp. Range, K	Reported Error, %	Name and Specimen Designation	Composition (weight percent), Specifications and Remarks
1	250	1943	53-295			35.89 Ca (36.11 theor.), 63.82 Cl (63.89 theor.) and 0.59 MgCl_2 ; prepared from pure calcite by dissolving in C.P. HCl followed by evaporation to obtain the hydrated crystals; crushed and slowly heated in a vacuum over several days to 130 C; dehydration completed by passing steam of dry hydrogen chloride over several days gradually raising the temperature to 74 C. (corrected for MgCl_2)

DATA TABLE NO. 248 SPECIFIC HEAT OF CALCIUM DICHLORIDE CaCl₂[Temperature, T, K; Specific Heat, Cp, Cal g⁻¹K⁻¹]

T	Cp
<u>CURVE 1</u>	
52.6	5.732 x 10 ⁻²
55.3	6.042
58.6	6.442
62.5	6.900
66.4	7.385
70.3	7.825
80.0	8.814
84.2	9.208
93.6	1.002 x 10 ⁻¹
103.3	1.075
113.4	1.141
123.7	1.201
134.3	1.254
144.3	1.296
154.0	1.332
164.4	1.366
174.3	1.391
184.6	1.415*
194.5	1.440
204.8	1.459*
214.6	1.472
224.7	1.488*
234.9	1.502
244.8	1.516*
255.0	1.530
265.7	1.538
275.8	1.551
285.8	1.555*
295.1	1.561

* Not shown on plot

FIG. 249

SPECIFIC HEAT OF CESIUM CHLORIDE CsCl

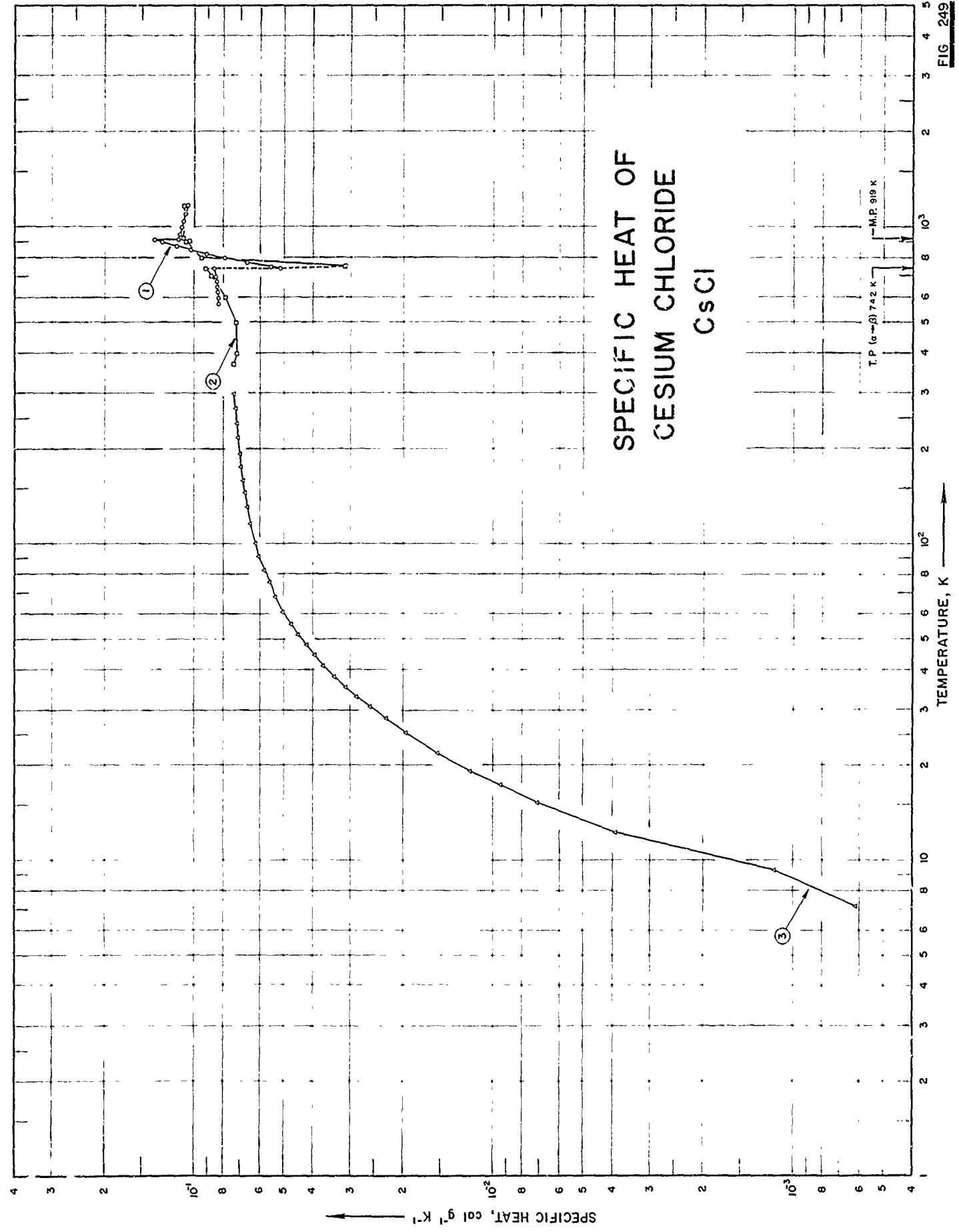

SPECIFICATION TABLE NO. 249 SPECIFIC HEAT OF CESIUM CHLORIDE CsCl

[For Data Reported in Figure and Table No. 249]

Curve No.	Ref. No.	Year	Temp. Range, K	Reported Error, %	Name and Specimen Designation	Composition (weight percent), Specifications and Remarks
1	251	1958	575-1175			< 0.1 each Li, K, Na and 0.01 Ca, total impurities < 0.2.
2	252	1961	370-1170			99.80 CsCl, < 0.1 each Li, Na, K, and < 0.01 Ca; resublimed, dried in a vacuum oven for several hrs.
3	253	1963	7-299	0.3		99.99 CsCl ₂ , 0.001-0.01 Al, Ca, K, Na, and Rb; chemically pure sample recrystallized several times from water and dried at temp. between 260-300 C in a vacuum for several hrs.

SPECIFIC HEAT OF
CHROMIUM DICHLORIDE
 CrCl_2

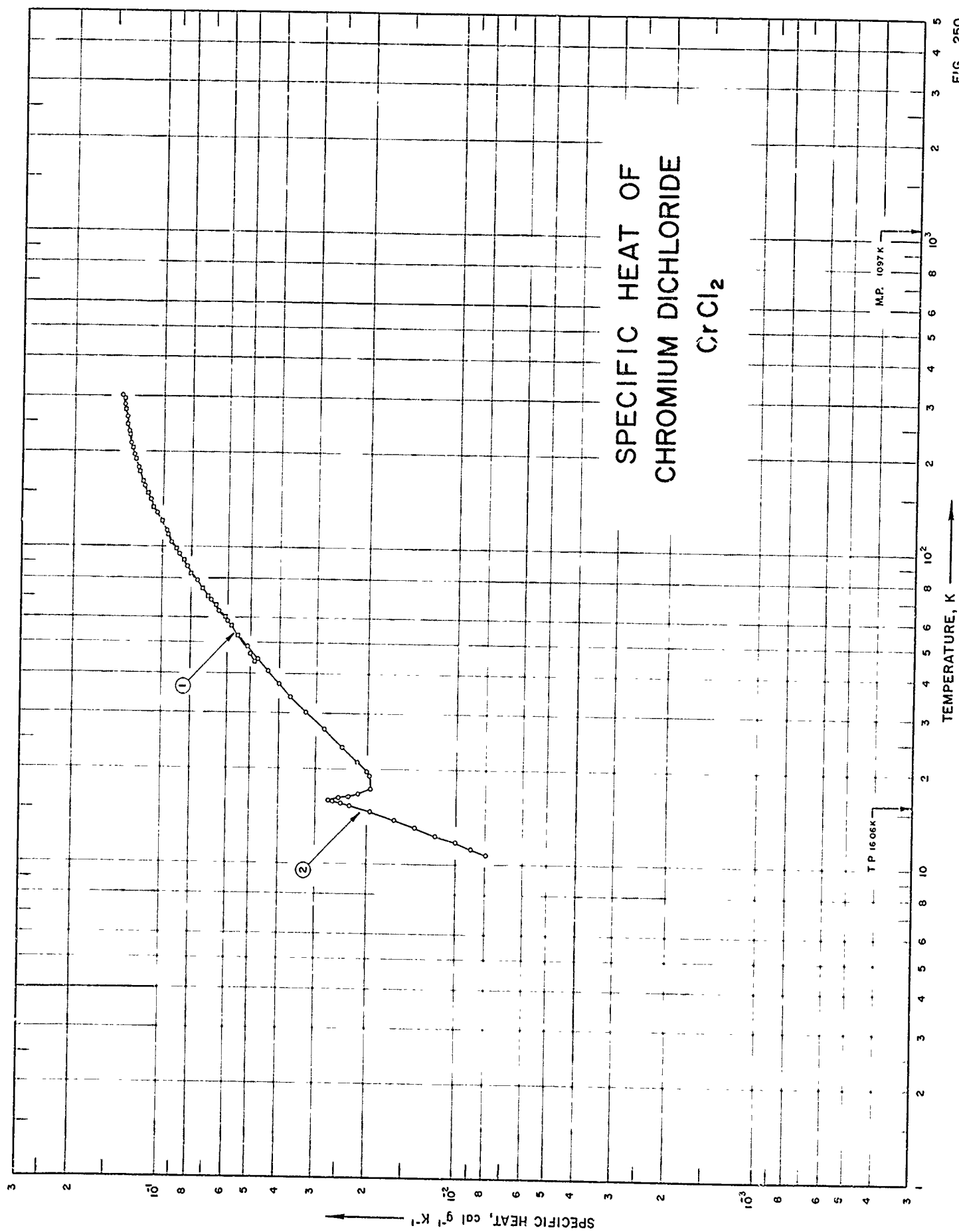

FIG. 250

SPECIFICATION TABLE NO. 250 SPECIFIC HEAT OF CHROMIUM DICHLORIDE CrCl_2

[For Data Reported in Figure and Table No. 250]

Curve No.	Ref. No.	Year	Temp. Range, K	Reported Error, %	Name and Specimen Designation	Composition (weight percent), Specifications and Remarks
1	60	1937	43-296			Grayish white substance; prepared from CrCl_3 by reduction of H_2 containing small amount of HCl .
2	254	1961	11-299			57.59 Cl (57.69 theo.), 42.21 Cr (42.31 theo.), 0.14 insol. in H_2O , and 0.001 each Fe and Ni; prepared from violet powdered CrCl_3 by passing HCl and H_2 gases in a furnace at 780 C.

DATA TABLE NO. 250 SPECIFIC HEAT OF CHROMIUM DICHLORIDE CrCl₂[Temperature, T, K; Specific Heat, Cp, Cal g⁻¹K⁻¹]

T	Cp	T	Cp	T	Cp	T	Cp
<u>CURVE 1</u>							
43.6	4.670 x 10 ⁻²	108.49	9.543 x 10 ⁻² *	14.63	1.956 x 10 ⁻²	16.56	2.270 x 10 ⁻² *
46.4	5.049	113.23	9.795	15.31	2.307	16.87	2.050*
49.5	5.231*	118.43	1.067 x 10 ⁻¹ *	16.22	2.520	17.20	1.961*
52.9	5.570	123.67	1.031*	17.40	1.960	Series 6	
54.7	5.660*	128.96	1.055	19.02	1.975	271.89	1.355*
56.7	5.842	133.94	1.077*	21.03	2.171	279.19	1.361*
55.2	5.955*	137.85	1.093*	23.50	2.451		
60.2	6.116	142.68	1.110	26.70	2.824		
65.9	6.588	147.52	1.130*	30.47	3.266		
70.0	7.012	152.45	1.145*	33.90	3.657		
74.3	7.330	157.78	1.163	37.13	4.017		
82.5	8.019	163.21	1.180*	40.87	4.398		
91.1	8.477	168.45	1.193*	44.73	4.775		
98.0	8.931	174.26	1.210*	48.80	5.170		
109.8	9.640	179.84	1.223	52.64	5.530*		
121.8	1.017 x 10 ⁻¹	185.15	1.235*	Series 3			
134.9	1.082	190.67	1.246*	14.68	1.974 x 10 ⁻² *		
148.3	1.130	196.66	1.257	15.33	2.317*		
162.4	1.172	201.71	1.269*	15.80	2.616		
174.3	1.211	208.56	1.277*	16.21	2.595*		
191.2	1.244	214.92	1.290	16.68	2.166		
206.8	1.273	221.10	1.299*	17.16	1.959*		
227.3	1.308	227.45	1.307*	17.85	1.900*		
245.3	1.332	233.36	1.315	18.48	1.929*		
273.5	1.356	239.32	1.324*	19.05	1.964		
295.1	1.361	245.71	1.329*	19.60	2.020		
296.1	1.363	251.72	1.334	Series 4			
<u>CURVE 2</u>							
Series 1							
53.60	5.617 x 10 ⁻² *	264.93	1.348*	15.60	2.465 x 10 ⁻²		
58.69	6.044	271.62	1.350*	15.92	2.693*		
63.37	6.455	277.92	1.362*	16.11	2.472*		
68.46	6.861	284.69	1.368	16.20	2.636*		
73.89	7.273*	291.70	1.374 x 10 ⁻¹ *	16.49	2.327		
78.87	7.651	298.50	1.381*	16.77	2.099*		
83.13	7.985*	301.83	1.389	17.03	1.985*		
87.27	8.274	Series 2					
91.49	8.550	10.73	7.997 x 10 ⁻³				
95.94	8.819	11.24	8.990				
100.30	9.079*	11.79	1.015 x 10 ⁻²				
104.58	9.323	12.43	1.185				
		13.14	1.385				
		13.86	1.630				
				15.63	2.506 x 10 ⁻² *		
				15.96	2.709		
				16.26	2.545*		

* Not shown on plot

SPECIFIC HEAT OF CHROMIUM TRICHLORIDE CrCl_3

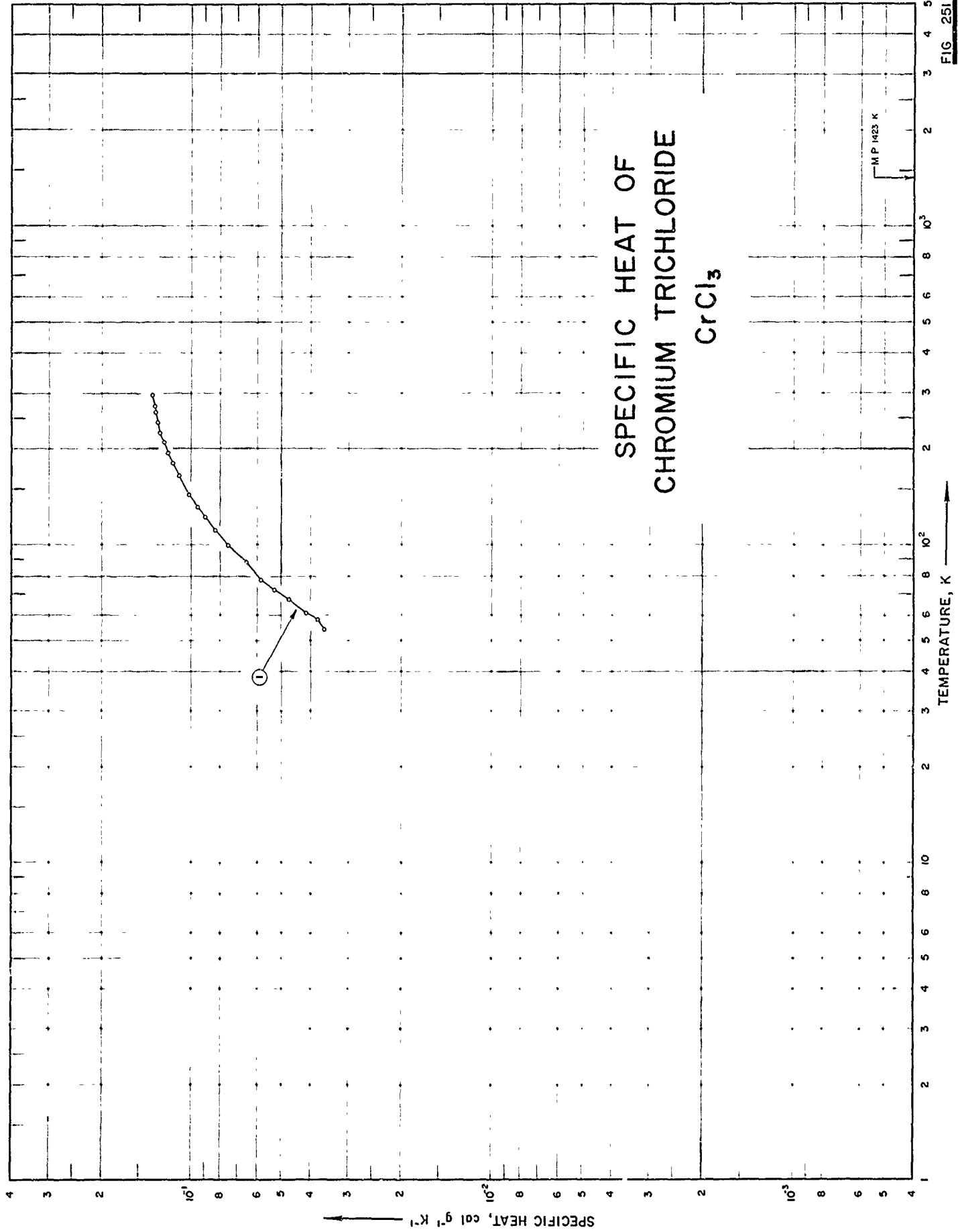

FIG. 251

SPECIFICATION TABLE NO. 251 SPECIFIC HEAT OF CHROMIUM TRICHLORIDE CrCl_3

[For Data Reported in Figure and Table No. 251]

Curve No.	Ref. No.	Year	Temp. Range, K	Reported Error, %	Name and Specimen Designation	Composition (weight percent), Specifications and Remarks
1	60	1937	54-297			Brilliant violet substance; prepared by passing Cl_2 gas through mixture of Cr_2O_3 and carbon at 800 C; compressed into pellets and dried by passing dry chloride containing a small amount of CCl_4 at 300 C; evacuated to remove excess chlorine.

DATA TABLE NO. 251 SPECIFIC HEAT OF CHROMIUM TRICHLORIDE CrCl_3 [Temperature, T. K.; Specific Heat, Cp, Cal $\text{g}^{-1}\text{K}^{-1}$]

T	Cp
54.4	3.602×10^{-2}
58.4	3.801
61.2	4.135
67.4	4.749
72.4	5.302
77.7	5.872
88.4	6.573
99.8	7.570
112.0	8.341
123.3	9.035
132.8	9.559
144.9	1.025×10^{-1}
165.9	1.110
181.6	1.162
195.7	1.203
211.2	1.240
225.6	1.289
243.0	1.301
261.9	1.320
272.6	1.328*
273.5	1.341
295.4	1.355*
296.9	1.363

CURVE 1

* Not shown on plot

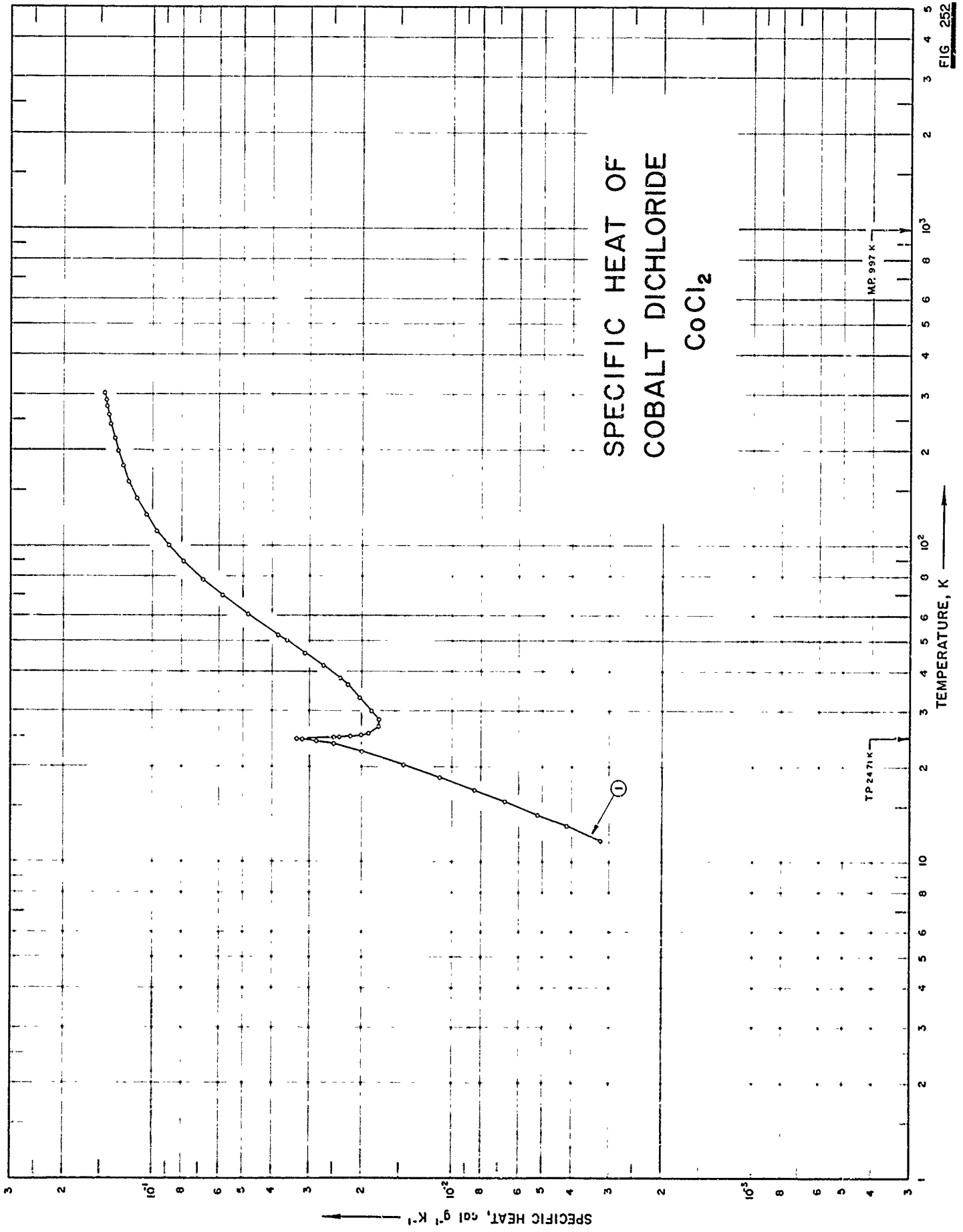

FIG. 252

SPECIFICATION TABLE NO. 252 SPECIFIC HEAT OF COBALT DICHLORIDE CoCl_2

[For Data Reported in Figure and Table No. 252]

Curve No.	Ref. No.	Year	Temp. Range, K	Reported Error, %	Name and Specimen Designation	Composition (weight percent), Specifications and Remarks
1	255	1961	12-304			45.27 Co (45.39 theor.), 54.65 Cl (54.61 theor.), 0.001 each Ca, Si, and Fe; prepared from $\text{Na}_2\text{Co}(\text{NO}_2)_6$ by dehydrating in a stream of HCl at 800 C.

DATA TABLE NO. 252 SPECIFIC HEAT OF COBALT DICHLORIDE CoCl_2 [Temperature, T, K; Specific Heat, Cp, Cal $\text{g}^{-1}\text{K}^{-1}$]

T	Cp	T	Cp	T	Cp
<u>CURVE 1</u>					
Series 1					
52.39	3.841×10^{-2}	246.68	$1.384 \times 10^{-1*}$	25.59	1.91×10^{-2}
55.74	4.346*	252.62	1.397*	25.80	1.87*
60.78	4.825	258.44	1.405	26.14	1.82*
65.28	5.355*	264.90	1.409*	26.51	1.80*
69.72	5.984	269.72	1.417*	26.92	1.78
74.23	6.386*	275.47	1.425	27.42	1.77*
78.35	6.822	282.17	1.430*	28.13	1.77
81.62	7.188*	288.16	1.432	Series 4	
85.44	7.577*	294.09	1.438*	24.45	$3.08 \times 10^{-2*}$
89.22	7.948	298.09	1.446*	24.58	3.32
92.87	8.271*	303.57	1.451	24.71	3.15*
96.53	8.587*	Series 2		24.84	2.50
100.34	8.887	11.69	3.20×10^{-3}	25.00	2.21*
104.16	9.172*	13.02	4.17	25.14	2.09*
108.27	9.489*	14.18	5.24	Series 5	
111.99	9.734	15.54	6.71	291.70	$1.455 \times 10^{-1*}$
116.38	1.003×10^{-1}	16.88	8.46	297.91	1.429*
120.77	1.030*	18.64	1.11×10^{-2}		
125.24	1.057	20.41	1.46		
129.59	1.080*	22.42	2.00		
133.84	1.101*	24.85	2.39		
137.56	1.119*	27.50	1.78*		
141.94	1.137	30.98	1.87		
145.96	1.156*	33.89	2.04		
150.27	1.172*	36.47	2.24		
154.55	1.189*	38.15	2.38		
159.48	1.206	41.82	2.71		
164.48	1.222*	45.87	3.11		
169.64	1.238*	50.17	3.57		
174.13	1.251*	Series 3			
178.29	1.261	22.12	$2.08 \times 10^{-2*}$		
183.48	1.275*	23.68	2.49		
188.75	1.285*	24.25	2.86		
193.84	1.298*	24.36	2.95*		
198.98	1.310	24.51	3.18		
204.24	1.322*	24.69	3.19*		
209.86	1.333*	24.86	2.35*		
215.25	1.343*	25.01	2.19		
218.98	1.348	25.13	2.09*		
224.76	1.357*	25.26	2.01		
230.66	1.362*	25.41	1.96*		
236.40	1.373*				
241.52	1.382				

* Not shown on plot

FIG 253

SPECIFIC HEAT OF COBALT DICHLORIDE HEXAHYDRATE $\text{CoCl}_2 \cdot 6\text{H}_2\text{O}$

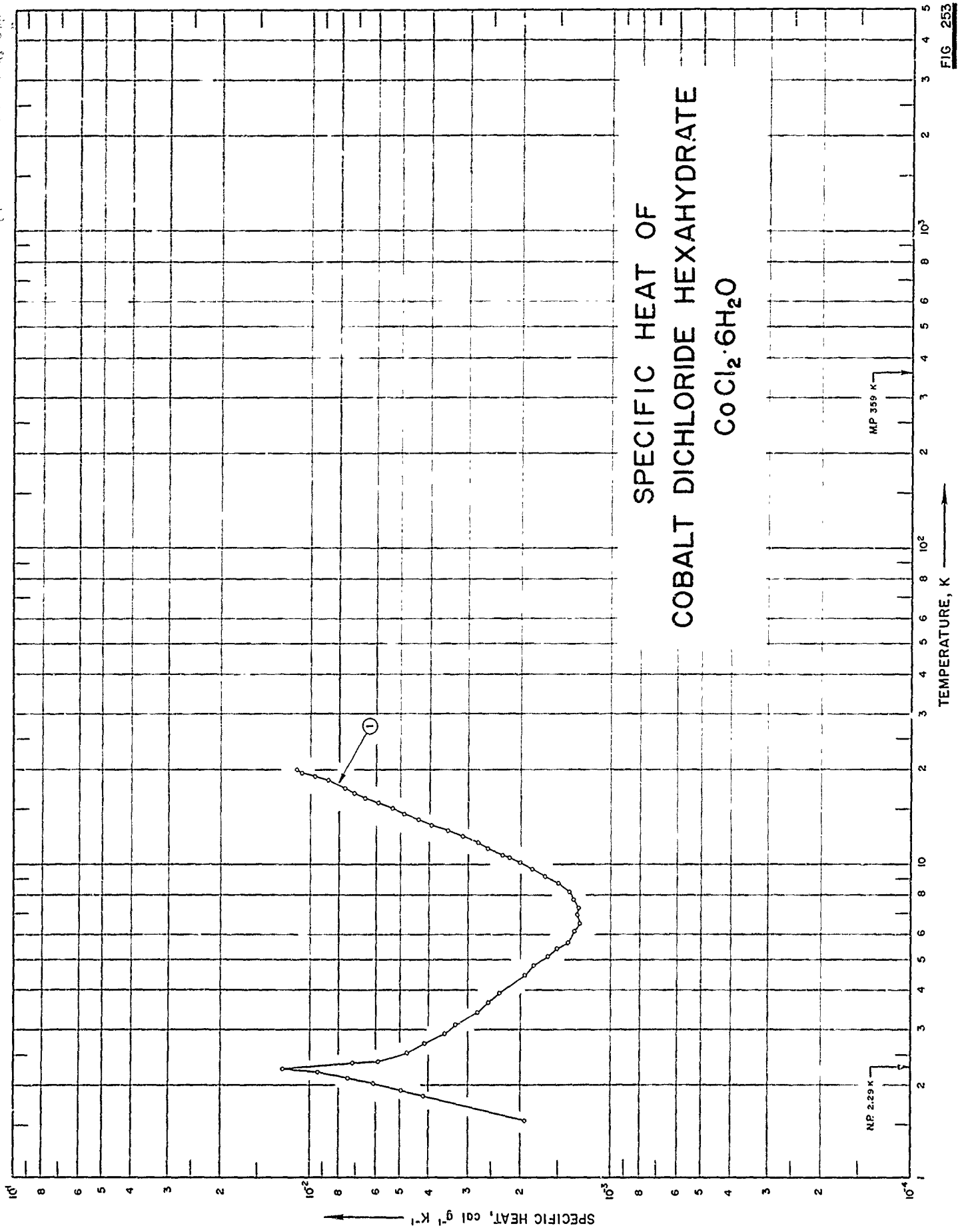

SPECIFICATION TABLE NO. 253 SPECIFIC HEAT OF COBALT DICHLORIDE HEXAHYDRATE $\text{CoCl}_2 \cdot 6\text{H}_2\text{O}$

[For Data Reported in Figure and Table No. 253]

Curve No.	Ref. No.	Year	Temp. Range, K	Reported Error, %	Name and Specimen Designation	Composition (weight percent), Specifications and Remarks
1	256	1959	1.5-20			Impurities: 0.06 substances not precipitated by $(\text{NH}_4)_2\text{S}$ as (SO_4) , 0.05 Ni, 0.02 Zn, 0.004 insol., 0.004 sulphide, 0.002 each Fe and ammonium; reagent grade; sample supplied by Fischer Scheinfire Supply Co.

DATA TABLE NO. 253 SPECIFIC HEAT OF COEALT DICHLORIDE HEXAHYDRATE $\text{CoCl}_2 \cdot 6\text{H}_2\text{O}$ [Temperature, T, K; Specific Heat, Cp, Cal $\text{g}^{-1}\text{K}^{-1}$]

T	Cp	T	Cp
1.5269	1.946×10^{-3}	16.0910	6.641×10^{-3}
1.8316	4.216	16.6930	7.229
1.9084	5.002	17.3090	7.734
2.0014	6.170	17.8750	8.658*
2.0870	7.532	18.4090	8.784
2.1700	9.474	18.9080	9.751
2.2494	1.244×10^{-2}	19.3660	1.072×10^{-2}
2.3448	7.254×10^{-3}	19.7950	1.122
2.3681	5.977		
2.5112	4.800		
2.6952	4.172		
2.8913	3.575		
3.0891	3.312		
3.3666	2.787		
3.6250	2.568		
3.8760	2.360		
4.1222	1.942		
4.7498	1.806		
5.0361	1.619		
5.3512	1.511		
5.6220	1.388		
6.0752	1.321		
6.4688	1.271		
6.8450	1.291		
7.2534	1.281		
7.6630	1.339		
8.1258	1.381		
8.6108	1.496		
9.0914	1.665		
9.5798	1.822		
10.0280	2.017		
10.4360	2.190		
10.1600	2.064^*		
10.6630	2.307		
11.1650	2.589		
11.6780	2.791		
12.1990	3.140		
12.7380	3.522		
13.2930	3.912		
13.8720	4.413		
14.4380	4.918		
14.9960	5.380		
15.5470	5.968		

* Not shown on plot

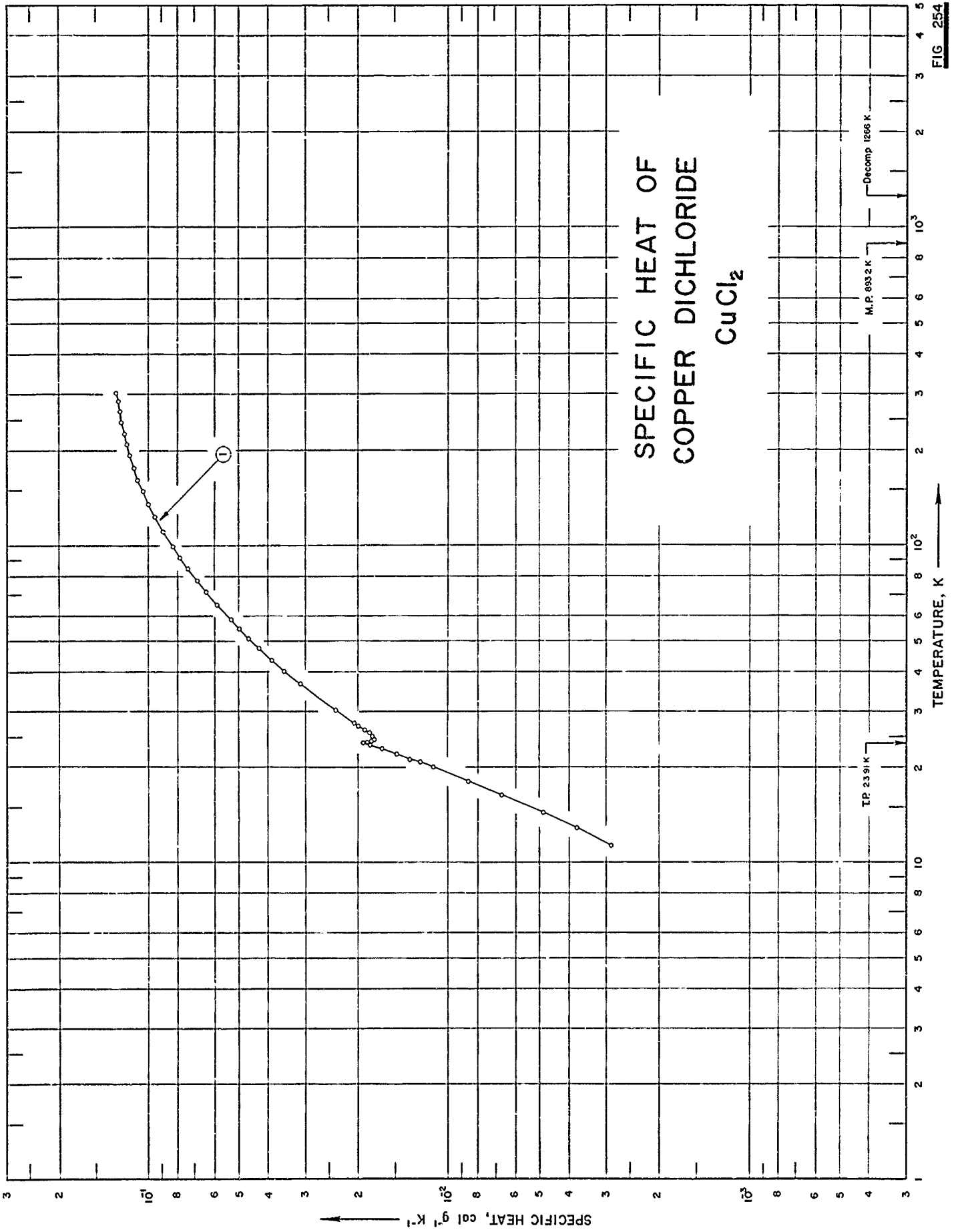

FIG 254

SPECIFICATION TABLE NO. 254 SPECIFIC HEAT OF COPPER DICHLORIDE CuCl_2

[For Data Reported in Figure and Table No. 254]

Curve No.	Ref. No.	Year	Temp. Range, K	Reported Error, %	Name and Specimen Designation	Composition (weight percent), Specifications and Remarks
1	254	1961	11-303			52.85 Cl_2 (52.74 theo.), 47.16 Cu (47.26 theo.), 0.001 each Al, Mg, Si, and Ag; dark brown powder; prepared from $\text{CuCl}_2 \cdot 2\text{H}_2\text{O}$ by dehydration.

DATA TABLE NO. 254 SPECIFIC HEAT OF COPPER DICHLORIDE CuCl_2 [Temperature, T, K; Specific Heat, Cp, Cal $\text{g}^{-1}\text{K}^{-1}$]

T	Cp	T	Cp	T	Cp
	<u>CURVE 1</u>		<u>CURVE 1 (cont.)</u>		<u>CURVE 1 (cont.)</u>
	Series 1				
300.55	1.283 x 10 ⁻¹	123.64	9.498 x 10 ⁻²	25.75	1.839 x 10 ⁻²
302.35	1.283	127.63	9.662*	26.36	1.900
303.04	1.282	131.76	9.833*	27.04	1.975*
		135.04	9.967	27.70	2.051
	Series 2	139.29	1.012 x 10 ⁻¹ *		
		143.62	1.028*	Series 5	
		148.04	1.043	23.54	1.822 x 10 ⁻² *
11.47	2.661 x 10 ⁻³	152.73	1.058*	23.70	1.882*
12.98	3.741	157.54	1.072*	23.85	1.897*
14.49	4.833	162.18	1.084	23.99	1.897*
16.40	6.627	166.93	1.098*	24.13	1.852*
18.10	8.545	171.77	1.110*	24.28	1.807*
20.02	1.115 x 10 ⁻²	176.77	1.122	24.42	1.778*
22.13	1.489	181.97	1.133*	24.58	1.778
24.24	1.805	187.36	1.145*		
27.09	1.984	193.06	1.155	Series 6	
30.42	2.372	198.80	1.165*	23.93	1.919 x 10 ⁻² *
33.59	2.751	204.33	1.174*	24.07	1.874*
36.77	3.124	209.69	1.180	24.22	1.822*
40.39	3.532	215.07	1.192*	24.36	1.793*
43.76	3.887	220.58	1.201*		
47.49	4.273	226.36	1.209	Series 7	
51.19	4.641	232.59	1.217*	282.83	1.267 x 10 ⁻² *
	Series 3	239.22	1.224*	290.04	1.270*
54.94	4.992 x 10 ⁻²	245.93	1.230		
58.63	5.326	252.58	1.238*		
62.05	5.625*	259.08	1.244*		
65.33	5.904	265.46	1.250		
68.73	6.172*	272.29	1.258*		
71.97	6.422	279.29	1.262*		
75.05	6.652*	285.72	1.268		
77.86	6.862	292.36	1.273*		
81.28	7.131*	298.09	1.276*		
84.81	7.382				
88.27	7.609*	Series 4			
91.91	7.839	20.86	1.243 x 10 ⁻²		
95.69	8.070*	21.42	1.343		
99.41	8.278	21.93	1.439*		
103.29	8.495*	22.41	1.537*		
107.36	8.710*	22.97	1.670		
111.50	8.918	23.51	1.822		
115.70	9.126*	24.03	1.870		
119.62	9.312*	24.58	1.770*		
		28.16	1.790		

* Not shown on plot

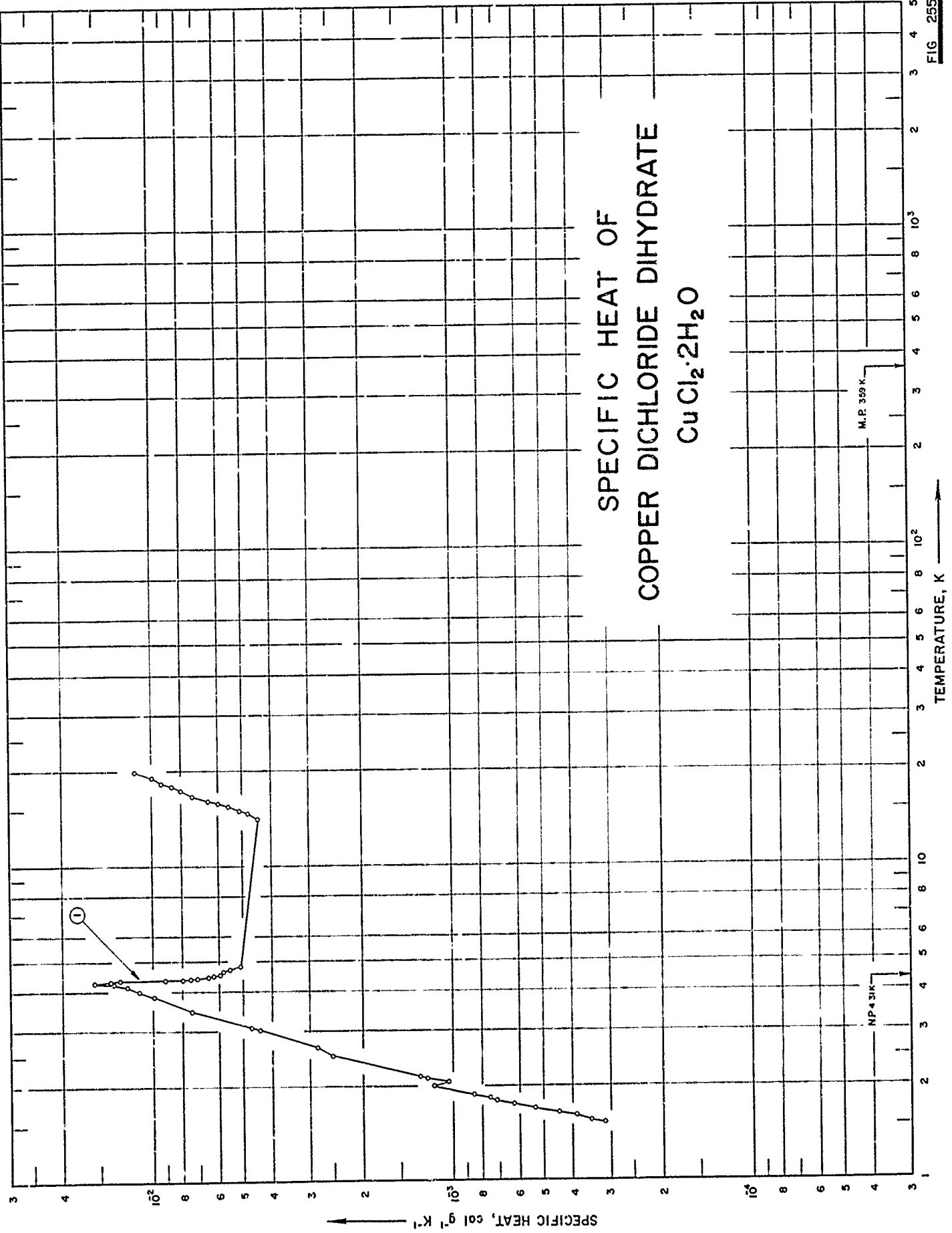

FIG. 255

SPECIFICATION TABLE NO. 255 SPECIFIC HEAT OF COPPER DICHLORIDE DIHYDRATE $\text{CuCl}_2 \cdot 2\text{H}_2\text{O}$

[For Data Reported in Figure and Table No. 255]

Curve No.	Ref. No.	Year	Temp. Range, K	Reported Error, %	Name and Specimen Designation	Composition (weight percent), Specifications and Remarks
1	257	1952	1.5-20			Purissimum grade; sample supplied by Brocades; specimen recrystallized three times from crude salt; measured under helium atmosphere.

DATA TABLE NO. 255 SPECIFIC HEAT OF COPPER DICHLORIDE DIHYDRATE $\text{CuCl}_2 \cdot 2\text{H}_2\text{O}$ [Temperature, T, K; Specific Heat, C_p , Cal $\text{g}^{-1}\text{K}^{-1}$]

T	C_p	T	C_p	T	C_p
CURVE 1		CURVE 1 (cont.)		CURVE 1 (cont.)	
Series 1					
2.492	2.529×10^{-3} *	4.848	5.089×10^{-3}	15.113	5.272×10^{-3} *
2.500	2.529	4.921	5.005*	15.215	5.314*
2.662	2.840	Series 3			
2.676	2.876*	1.534	3.126×10^{-4}	15.408	5.790*
2.719	2.876*	1.556	3.477	15.605	5.790*
3.028	4.430	1.585	3.561*	15.781	6.071
3.041	4.537*	1.612	3.898	15.954	6.351*
3.061	4.601*	1.655	4.430	16.121	6.505
3.079	4.719	1.700	5.356	16.281	6.772*
3.470	7.403	1.764	6.309	16.426	6.688*
3.485	7.501*	1.806	7.164	16.624	7.304
3.500	7.501*	1.845	7.515	16.825	7.206*
3.514	7.641*	1.887	8.510	17.017	7.627*
3.535	7.739*	2.020	1.162×10^{-3}	17.205	7.781*
3.867	9.912	2.067	1.044	17.387	8.033
3.882	1.021×10^{-2} *	2.114	1.227	17.514	8.230*
3.901	1.023*	2.150	1.280	17.692	8.496*
3.923	1.053*	4.091	1.227×10^{-2} *	17.851	8.580
4.009	1.117	4.136	1.286*	18.028	8.622*
4.035	1.140*	4.156	1.308*	18.219	9.001*
4.059	1.150*	4.175	1.338*	18.315	9.295
4.084	1.182*	4.210	1.374*	18.691	9.478*
Series 2					
4.188	1.227×10^{-2}	4.232	1.409*	18.880	9.772*
4.213	1.326*	4.249	1.350	19.069	9.996
4.243	1.431*	4.263	1.468*	19.226	1.032 $\times 10^{-2}$ *
4.264	1.579	4.265	1.490*	19.428	1.046*
4.308	1.590*	4.285	1.560*	19.621	1.108*
4.313	1.385	4.310	1.396*	19.813	1.145
4.402	7.459×10^{-3}	4.341	1.286		
4.450	6.533	4.365	9.099×10^{-3}		
4.477	6.744*	4.386	7.921		
4.496	6.281	4.407	7.332*		
4.536	6.169*	4.431	7.108		
4.566	5.987	Series 4			
4.596	5.930*	14.0°3	4.458×10^{-3}		
4.625	5.832	14.183	4.402*		
4.654	5.664*	14.256	4.514*		
4.709	5.510	14.476	4.585*		
4.777	5.384*	14.698	4.795		
		14.910	5.117		

* Not shown on plot

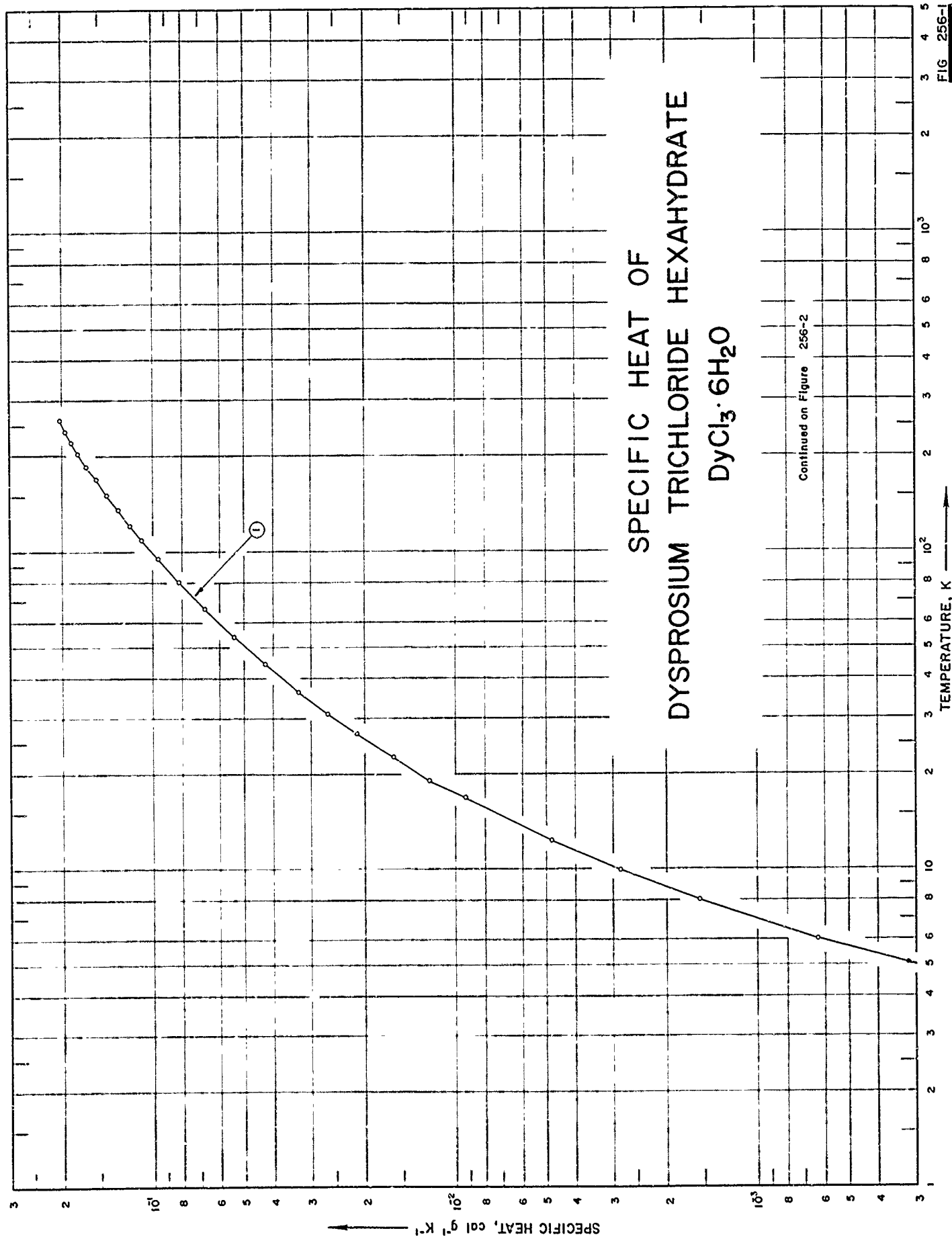

SPECIFIC HEAT OF DYSPROSIUM TRICHLORIDE HEXAHYDRATE $DyCl_3 \cdot 6H_2O$

CONTINUED FROM FIGURE 256 -1

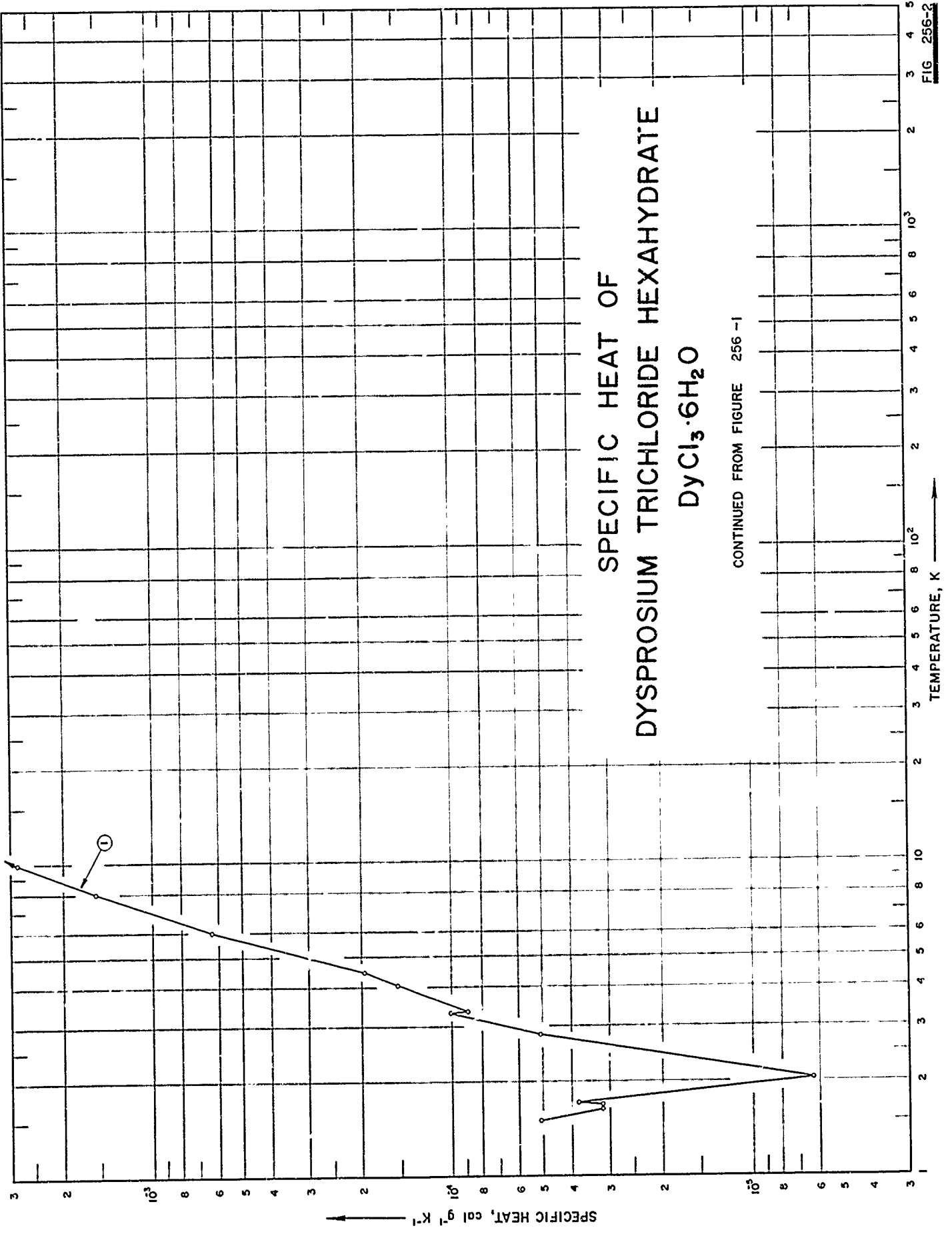

SPECIFICATION TABLE NO. 256 SPECIFIC HEAT OF DYSPROSIUM TRICHLORIDE HEXAHYDRATE $DyCl_3 \cdot 6H_2O$

[For Data Reported in Figure and Table No. 256]

Curve No.	Ref. No.	Year	Temp. Range, K	Reported Error, %	Name and Specimen Designation	Composition (weight percent), Specifications and Remarks
1	319	1961	1.5-260			

DATA TABLE NO. 256 SPECIFIC HEAT OF DYSPROSIUM TRICHLORIDE HEXAHYDRATE $DyCl_3 \cdot 6H_2O$ [Temperature, T, K; Specific Heat, C_p , Cal $g^{-1}K^{-1}$]

T	C_p
	<u>CURVE I</u>
1.51	5.07×10^{-6}
1.63	3.17
1.69	3.17
1.72	3.80
2.04	6.34×10^{-6}
2.83	5.07×10^{-5}
3.32	1.01×10^{-4}
3.35	8.88×10^{-5}
4.07	1.52×10^{-4}
4.49	1.97
6.16	6.34
8.06	1.56×10^{-3}
9.95	2.85
12.37	4.81
14.46	6.77
16.76	9.28
19.15	1.23×10^{-2}
22.62	1.61
26.97	2.15
31.03	2.66
36.45	3.31
41.54	4.28
54.44	5.43
66.57	6.765
80.96	8.217
95.88	9.612
109.66	1.091×10^{-1}
122.39	1.192
136.47	1.302
152.39	1.422
170.02	1.545
187.69	1.662
205.56	1.773
223.52	1.869
240.99	1.958
260.13	2.047

* Not shown on plot

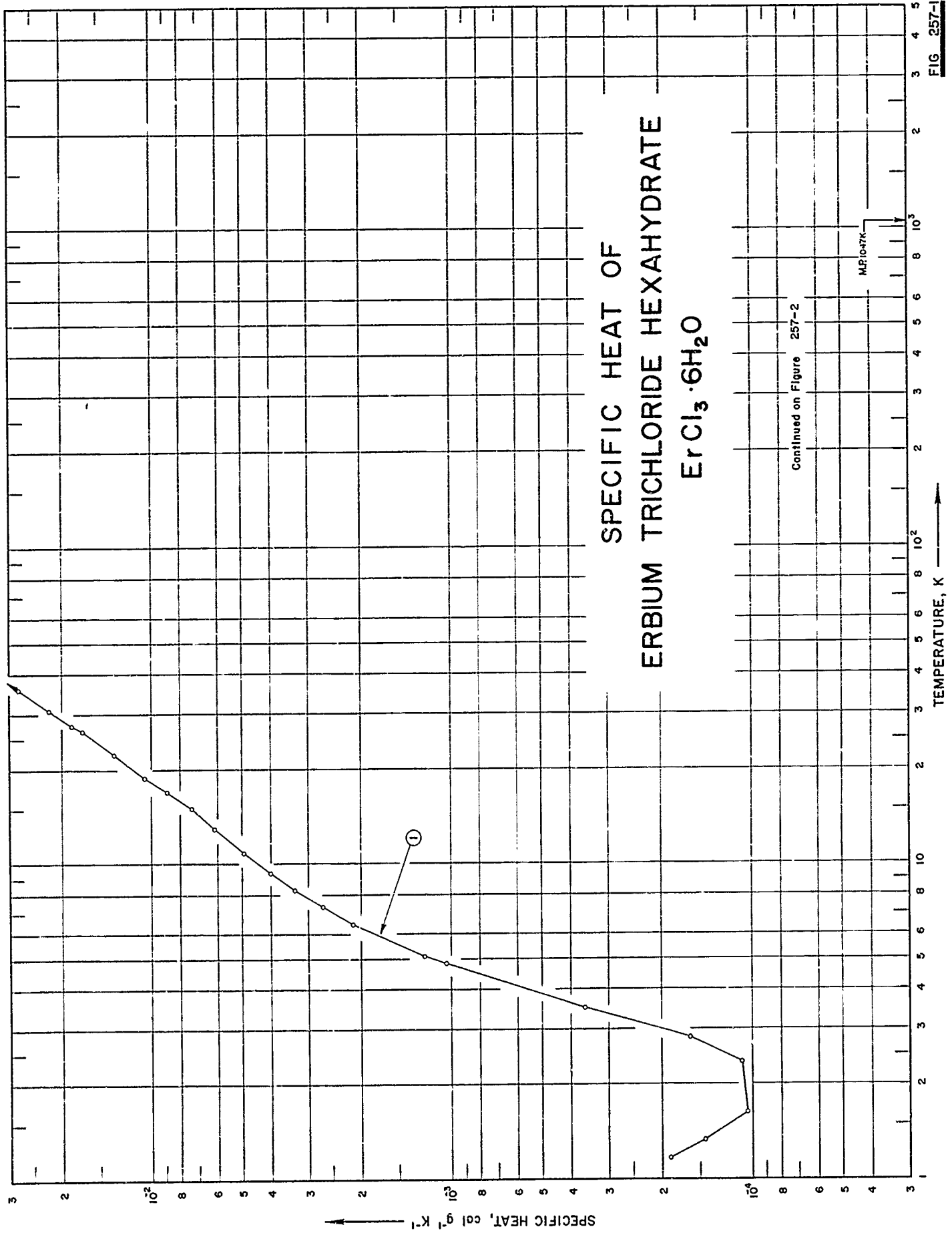

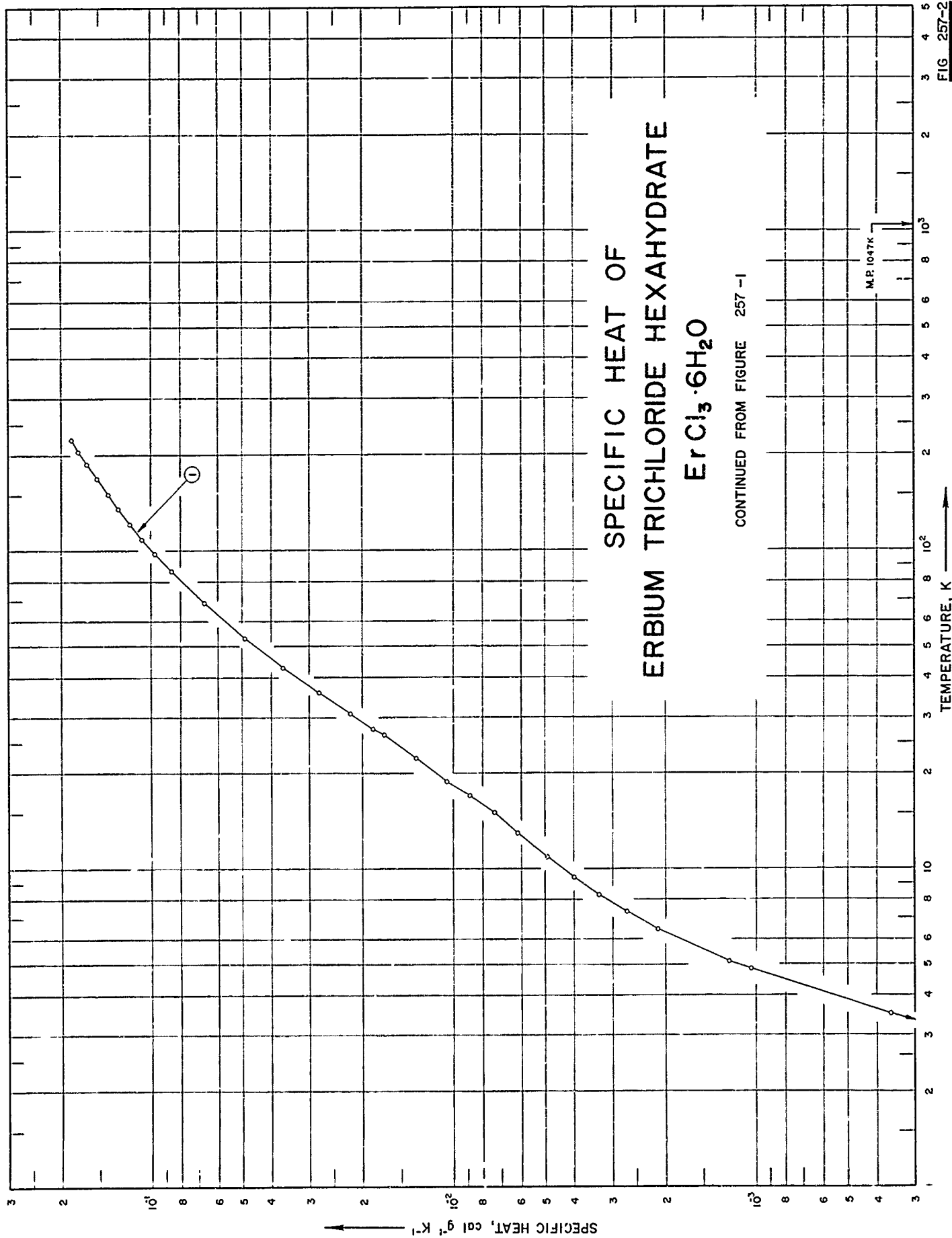

SPECIFIC HEAT OF
 ERBIUM TRICHLORIDE HEXAHYDRATE
 $\text{ErCl}_3 \cdot 6\text{H}_2\text{O}$

CONTINUED FROM FIGURE 257-1

M.P. 1047K

SPECIFICATION TABLE NO. 257 SPECIFIC HEAT OF ERBIUM TRICHLORIDE HEXAHYDRATE $\text{ErCl}_3 \cdot 6\text{H}_2\text{O}$

[For Data Reported in Figure and Table No. 257]

Curve No.	Ref. No.	Year	Temp. Range, K	Reported Error, %	Name and Specimen Designation	Composition (weight percent), Specifications and Remarks
J	320	1961	1.2-224			Prepared from 99.96 Er_2O_3 .

DATA TABLE NO. 257 SPECIFIC HEAT OF ERBIUM TRICHLORIDE HEXAHYDRATE $\text{ErCl}_3 \cdot 6\text{H}_2\text{O}$

[Temperature, T, K; Specific Heat, C_p , Cal $\text{g}^{-1}\text{K}^{-1}$]

T	C_p
	CURVE 1
1.17	1.878×10^{-4}
1.34	1.446
1.63	1.046
2.36	1.089
2.81	1.615
3.50	3.613
4.86	1.048×10^{-3}
5.12	1.231
6.48	2.125
7.36	2.691
8.30	3.348
9.42	4.014
10.98	4.940
13.06	6.174
15.14	7.382
17.02	8.879
18.86	1.061×10^{-2}
22.33	1.332
22.41	1.354*
26.54	1.705
27.65	1.855
30.87	2.213
35.98	2.799
43.10	3.687
53.35	4.940
68.71	6.732
86.65	8.616
98.12	9.768
108.84	1.073
109.49	1.082*
122.39	1.187
136.29	1.297
151.89	1.408
169.34	1.528
187.29	1.657
205.57	1.763
224.05	1.856

* Not shown on plot

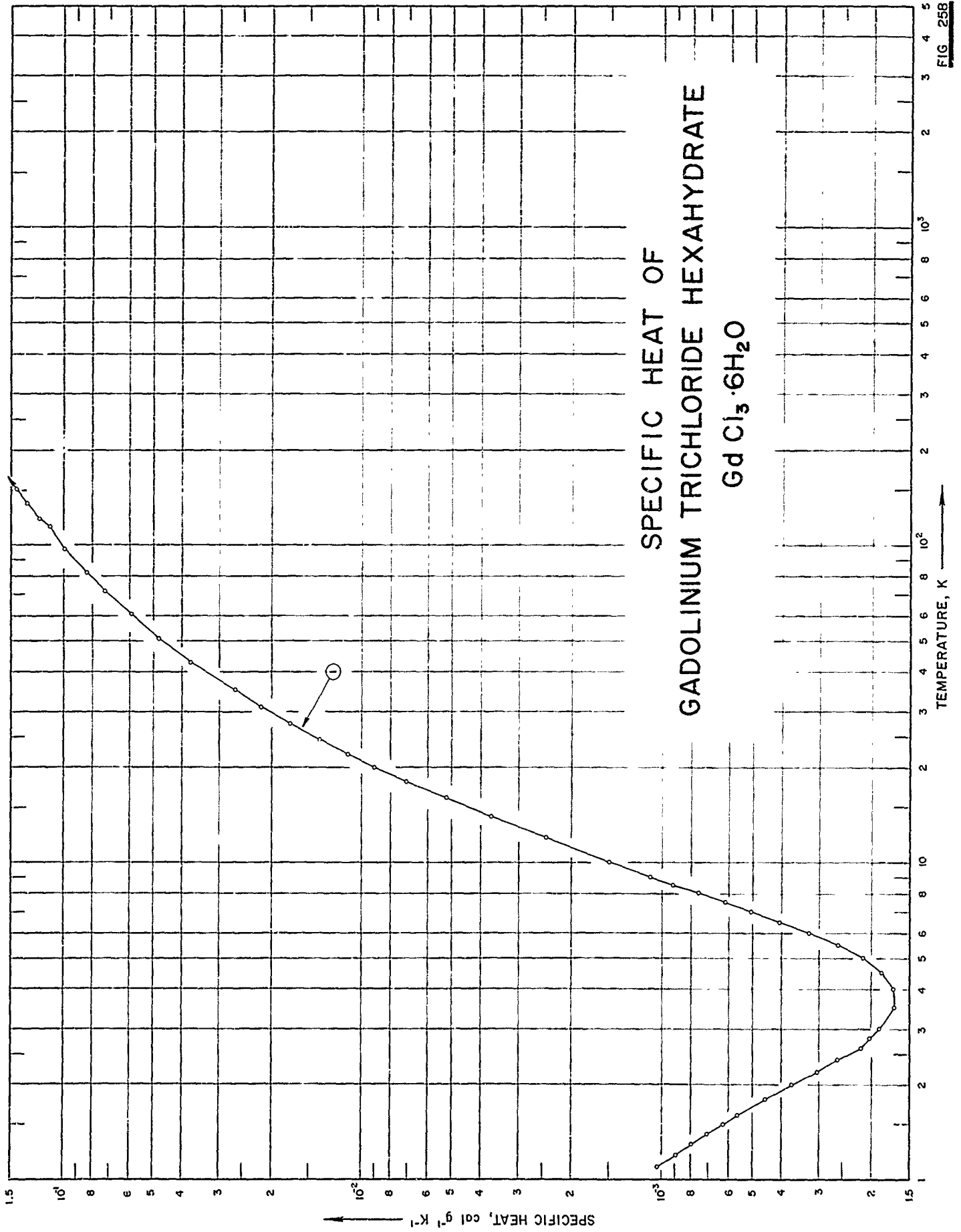

SPECIFICATION TABLE NO. 258 SPECIFIC HEAT OF GADOLINIUM TRICHLORIDE HEXAHYDRATE $GdCl_3 \cdot 6H_2O$

[For Data Reported in Figure and Table No. 258]

Curve No.	Ref. No.	Year	Temp. Range, K	Reported Error, %	Name and Specimen Designation	Composition (weight percent), Specifications and Remarks
1	321	1961	1.1-259			Prepared from 99.9 Gd_2O_3 and HCl.

DATA TABLE NO. 258 SPECIFIC HEAT OF GADOLINIUM TRICHLORIDE HEXAHYDRATE $GdCl_3 \cdot 6H_2O$ [Temperature, T, K; Specific Heat, C_p , Cal $g^{-1}K^{-1}$]

T	C_p	
	CURVE 1	CURVE 1 (cont.)
1.1	1.039×10^{-3}	137.0
1.2	8.966×10^{-4}	152.0
1.3	1.982	170.0
1.4	7.068	187.0
1.5	6.258	205.0
1.6	5.615	224.0
1.8	4.534	242.0
2.0	3.692	259.0
2.2	3.055	
2.4	2.605	
2.6	2.161	
2.8	2.039	
3.0	1.878	
3.5	1.679	
4.0	1.685	
4.5	1.852	
5.0	2.135	
5.5	2.592	
6.0	3.261	
6.5	4.071	
7.0	5.081	
7.5	6.181	
8.0	7.564	
8.5	9.197	
9.0	1.097×10^{-3}	
10.0	1.502	
12.0	2.444	
14.0	3.692	
16.0	5.223	
18.0	7.094	
20.0	9.062	
22.0	1.118×10^{-2}	
24.5	1.382	
27.5	1.744	
31.0	2.169	
35.0	2.663	
43.0	3.732	
51.0	4.758	
61.0	5.946	
72.0	7.256	
82.5	8.362	
97.5	9.921	
110.5	1.114×10^{-1}	
122.5	1.215	

* Not shown on plot

SPECIFIC HEAT OF
HOLMIUM TRICHLORIDE HEXAHYDRATE
 $\text{HoCl}_3 \cdot 6\text{H}_2\text{O}$

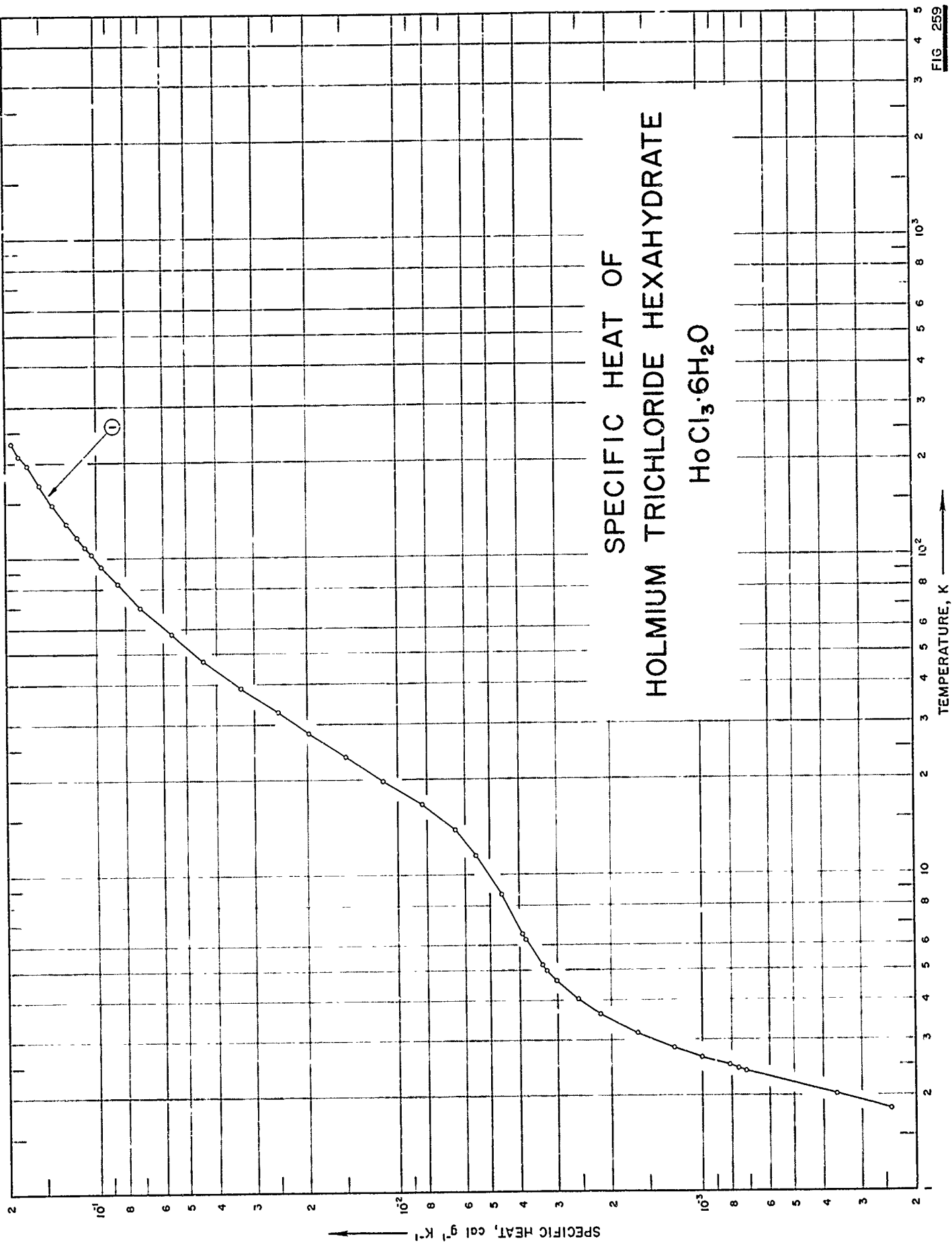

SPECIFICATION TABLE NO. 259 SPECIFIC HEAT OF HOLMIUM TRICHLORIDE HEXAHYDRATE $\text{HoCl}_3 \cdot 6\text{H}_2\text{O}$

[For Data Reported in Figure and Table No. 259]

Curve No.	Ref. No.	Year	Temp. Range, K	Reported Error, %	Name and Specimen Designation	Composition (weight percent), Specifications and Remarks
1	320	1961	1.4-231			Prepared from 99.9 Ho_2O_3 .

DATA TABLE NO. 259 SPECIFIC HEAT OF HOLMIUM TRICHLORIDE HEXAHYDRATE $\text{HoCl}_3 \cdot 6\text{H}_2\text{O}$ [Temperature, T, K; Specific Heat, C_p , Cal $\text{g}^{-1}\text{K}^{-1}$]

T	C_p
	<u>CURVE 1</u>
1.39	1.266×10^{-4} *
1.82	2.400
2.01	3.635
2.38	7.169
2.44	7.617
2.50	8.146
2.64	1.007×10^{-3}
2.85	1.244
3.15	1.642
3.63	2.180
4.04	2.570
4.63	3.043
4.97	3.263
5.19	3.371
6.23	3.849
6.51	3.944
3.69	4.631
11.52	5.582
13.93	6.508
16.73	8.385
19.80	1.126×10^{-2}
23.62	1.499
28.09	1.987
32.72	2.512
39.01	3.326
47.76	4.425
58.01	5.649
70.37	7.132
83.60	8.499
94.98	9.614
103.09	1.029×10^{-1} *
103.83	1.044
109.31	1.093
117.71	1.160
118.17	1.188*
129.98	1.261
130.27	1.259*
148.00	1.394
149.21	1.401*
170.72	1.545
190.74	1.687
211.28	1.809
230.76	1.913

* Not shown on plot

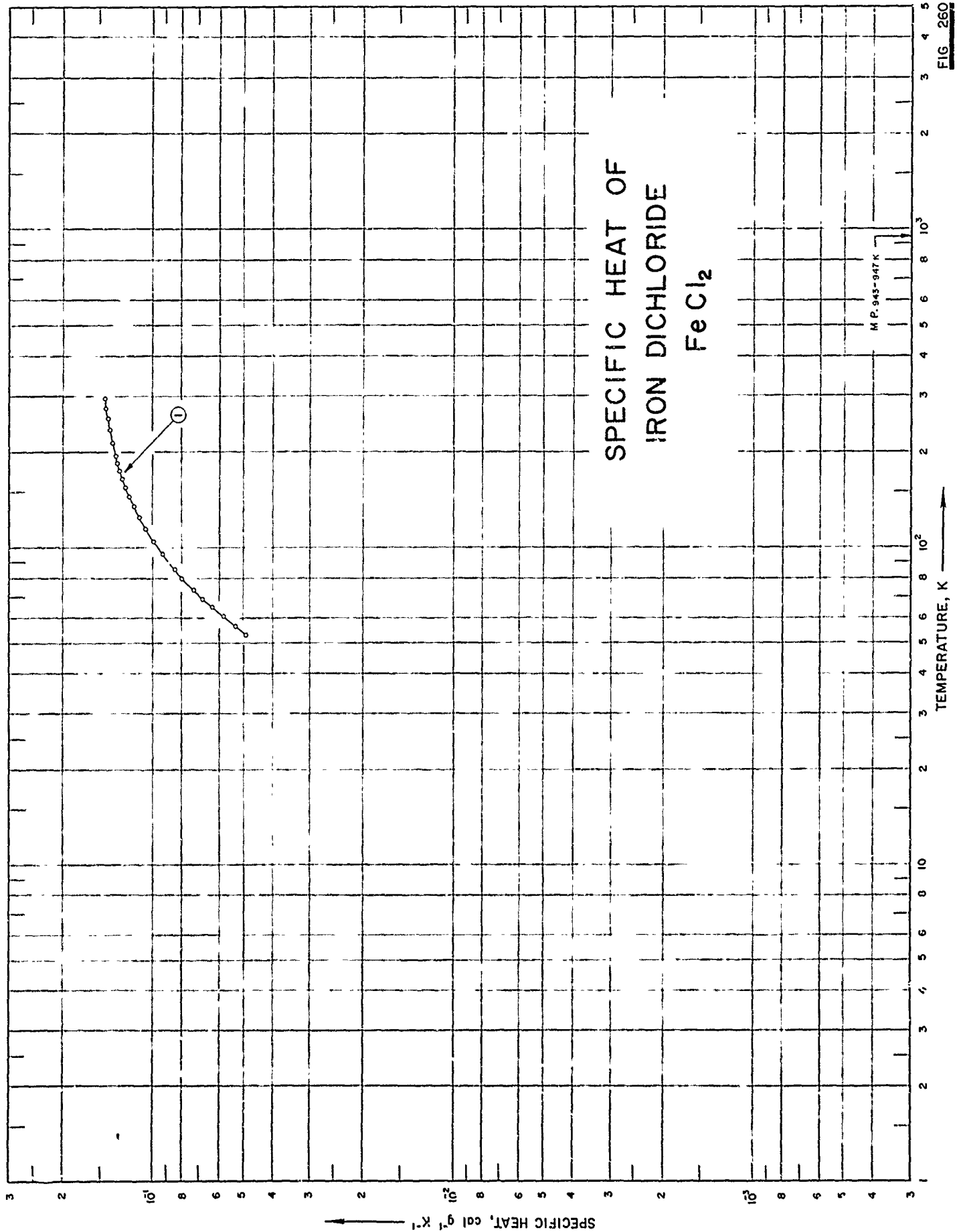

SPECIFICATION TABLE NO. 260 SPECIFIC HEAT OF IRON DICHLORIDE FeCl₂

[For Data Reported in Figure and Table No. 260]

Curve No.	Ref. No.	Year	Temp. Range, K	Reported Error, %	Name and Specimen Designation	Composition (weight percent), Specifications and Remarks
1	250	1943	53-295			44.13 Fe (44.06 theor.), 55.85 Cl (55.94 theo.); prepared from FeCl ₂ ·4H ₂ O by heating slowly in vacuum to 200 and then in steam of dry HCl, temp gradually raised to 550 C.

DATA TABLE NO. 260 SPECIFIC HEAT OF IRON DICHLORIDE

[Temperature, T, K; Specific Heat, Cp, Cal g⁻¹K⁻¹]

T	Cp
<u>CURVE 1</u>	
53.2	4.885 x 10 ⁻²
56.7	5.289
60.8	5.790
65.2	6.337
69.3	6.827
73.6	7.297
80.6	7.991
85.5	8.433
95.4	9.269
105.1	9.940
115.2	1.056 x 10 ⁻¹
125.2	1.110
135.6	1.158
145.8	1.197
155.5	1.230
165.9	1.259
175.3	1.284
185.3	1.306
195.2	1.327
205.0	1.341*
214.9	1.357
225.1	1.373*
235.2	1.385
245.6	1.398*
255.4	1.407
265.6	1.415*
275.9	1.427
285.7	1.430*
295.0	1.437

*Not shown on plot

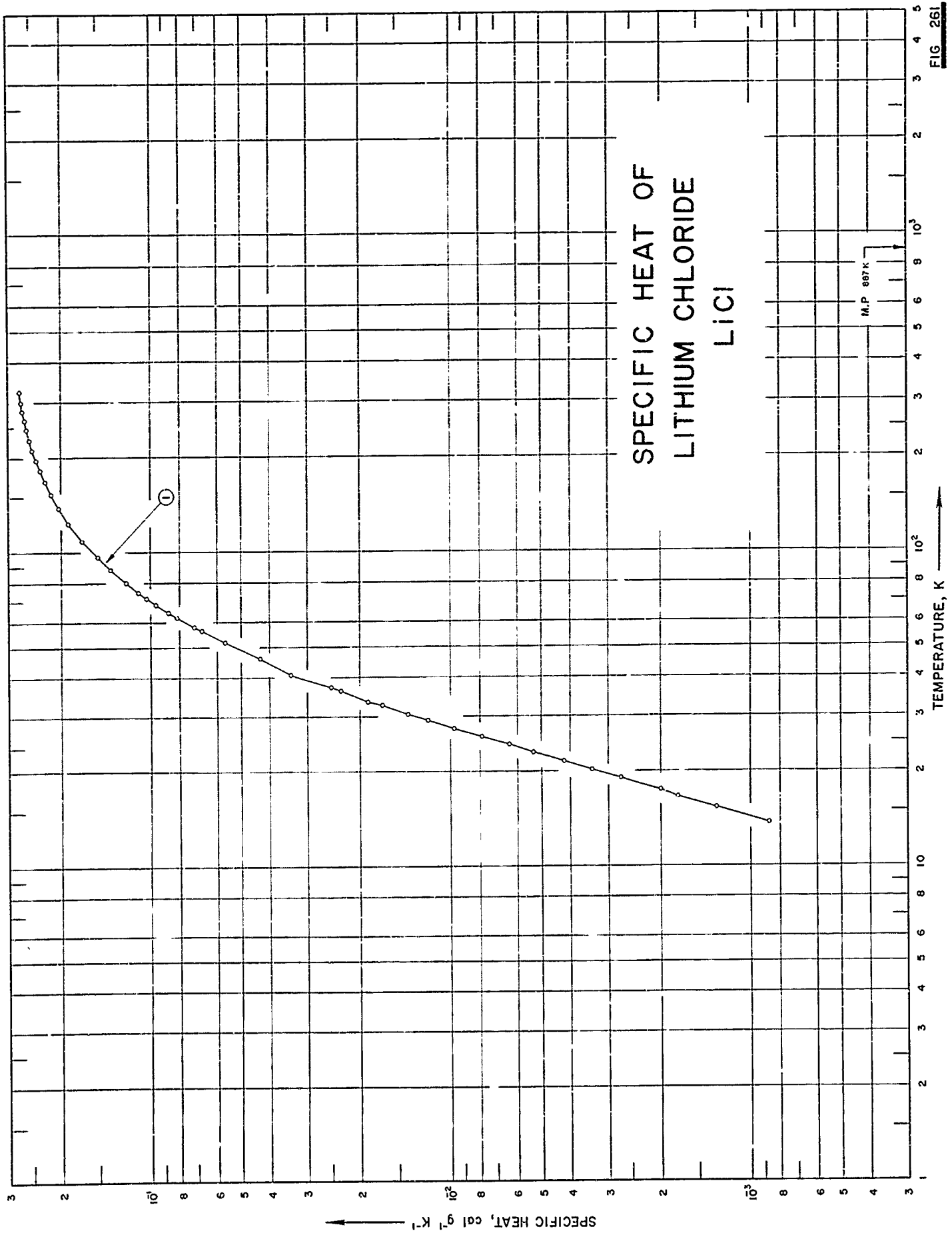

FIG. 261

SPECIFICATION TABLE NO. 261 SPECIFIC HEAT OF LITHIUM CHLORIDE LiCl

[For Data Reported in Figure and Table No. 261]

Curve No.	Ref. No.	Year	Temp. Range, K	Reported Error, %	Name and Specimen Designation	Composition (weight percent), Specifications and Remarks
1	322	1960	14-320	0.1-1		99.1 LiCl, 0.06 Na, 0.03 K, 0.006 alkalinity, 0.005 SO ₄ , 0.005 insol. matter, 0.002 Ca and 0.0005 NO ₃ ; purified by recrystallization and fused.

DATA TABLE NO. 261 SPECIFIC HEAT OF LITHIUM CHLORIDE LiCl

[Temperature, T, K; Specific Heat, Cp, Cal g⁻¹K⁻¹]

T	Cp		
	CURVE 1	CURVE 1 (cont.)	
	Series 1	Series 2	
16.65	1.761 x 10 ⁻³	272.31	2.656 x 10 ⁻¹
19.07	2.734	280.78	2.677
21.64	4.244	290.11	2.689*
24.40	6.419	299.64	2.709
27.49	9.778	309.77	2.723*
30.59	1.337 x 10 ⁻²	320.42	2.742
33.81	1.290		
37.37	2.517		
41.70	3.383*	13.77	8.707 x 10 ⁻⁴
46.58	4.449*	15.42	1.310 x 10 ⁻³
51.39	5.561*	17.54	2.004
56.60	6.794	20.38	3.406
62.36	8.192	23.03	5.301
68.53	9.644	25.84	7.905
74.98	1.106 x 10 ⁻¹	29.27	1.194 x 10 ⁻²
81.43	1.239*	32.67	1.692
88.01	1.362*	36.36	2.325
95.08	1.486*	40.83	3.430
102.03	1.537*	46.05	4.337
109.30	1.701	51.94	5.665
116.72	1.798*	58.29	7.187
124.12	1.890	64.71	8.737
131.52	1.965*	71.80	1.038 x 10 ⁻¹
138.83	2.038	80.03	1.208
146.06	2.104*	88.52	1.370
153.34	2.161	97.03	1.517
160.92	2.219*		
168.45	2.265		
175.72	2.306*		
182.99	2.349		
190.21	2.384*		
197.56	2.421		
204.91	2.454*		
212.60	2.484		
219.84	2.512*		
227.52	2.547		
235.07	2.563*		
242.55	2.567*		
246.90	2.584		
249.94	2.367*		
255.11	2.608*		
263.92	2.638		

* Not shown on plot

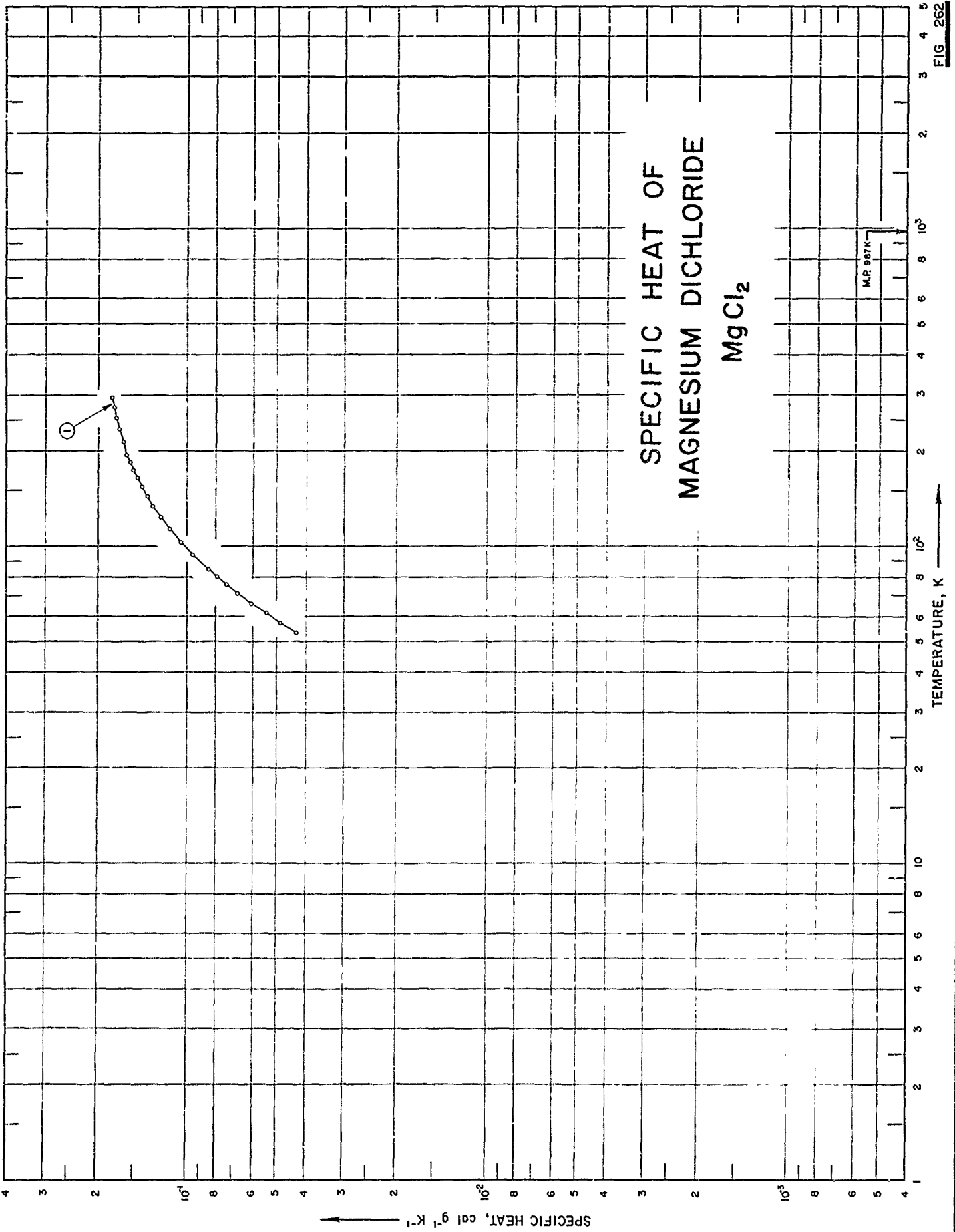

FIG. 262

SPECIFICATION TABLE NO. 262 SPECIFIC HEAT OF MAGNESIUM DICHLORIDE $MgCl_2$

[For Data Reported in Figure and Table No. 262]

Curve No.	Ref. No.	Year	Temp. Range, K	Reported Error, %	Name and Specimen Designation	Composition (weight percent), Specifications and Remarks
1	250	1943	54-295			74.25 Cl (74.46 theo), 25.74 Mg (25.54 theo), 0.2 MgO; prepared from magnesium ammonium chloride hexahydrate by heating slowly to 200 C and then by a stream of dry HCl to 400 C; heated several more days in stream of dry HCl at 500 to 600 C; evacuated and cooled. (corrected for MgO impurities)

DATA TABLE NO. 262 SPECIFIC HEAT OF MAGNESIUM DICHLORIDE MgCl_2
 [Temperature, T, K; Specific Heat, Cp, Cal $\text{g}^{-1}\text{K}^{-1}$]

T	Cp
	4.320 x 10 ⁻²
53.6	4.851
57.6	5.418
61.8	6.064
65.2	6.765
71.4	7.370
76.1	7.925
80.4	8.453
84.8	8.952
94.2	1.049 x 10 ⁻¹
103.9	1.144
114.2	1.223
123.9	1.302
134.9	1.362
144.6	1.420
155.3	1.467
165.1	1.506
185.1	1.547
195.0	1.584
204.8	1.608*
215.3	1.636
225.1	1.660*
235.2	1.682
245.0	1.702*
255.3	1.722
266.1	1.739*
276.5	1.758
286.1	1.768*
295.4	1.783

* Not shown on plot

FIG. 263

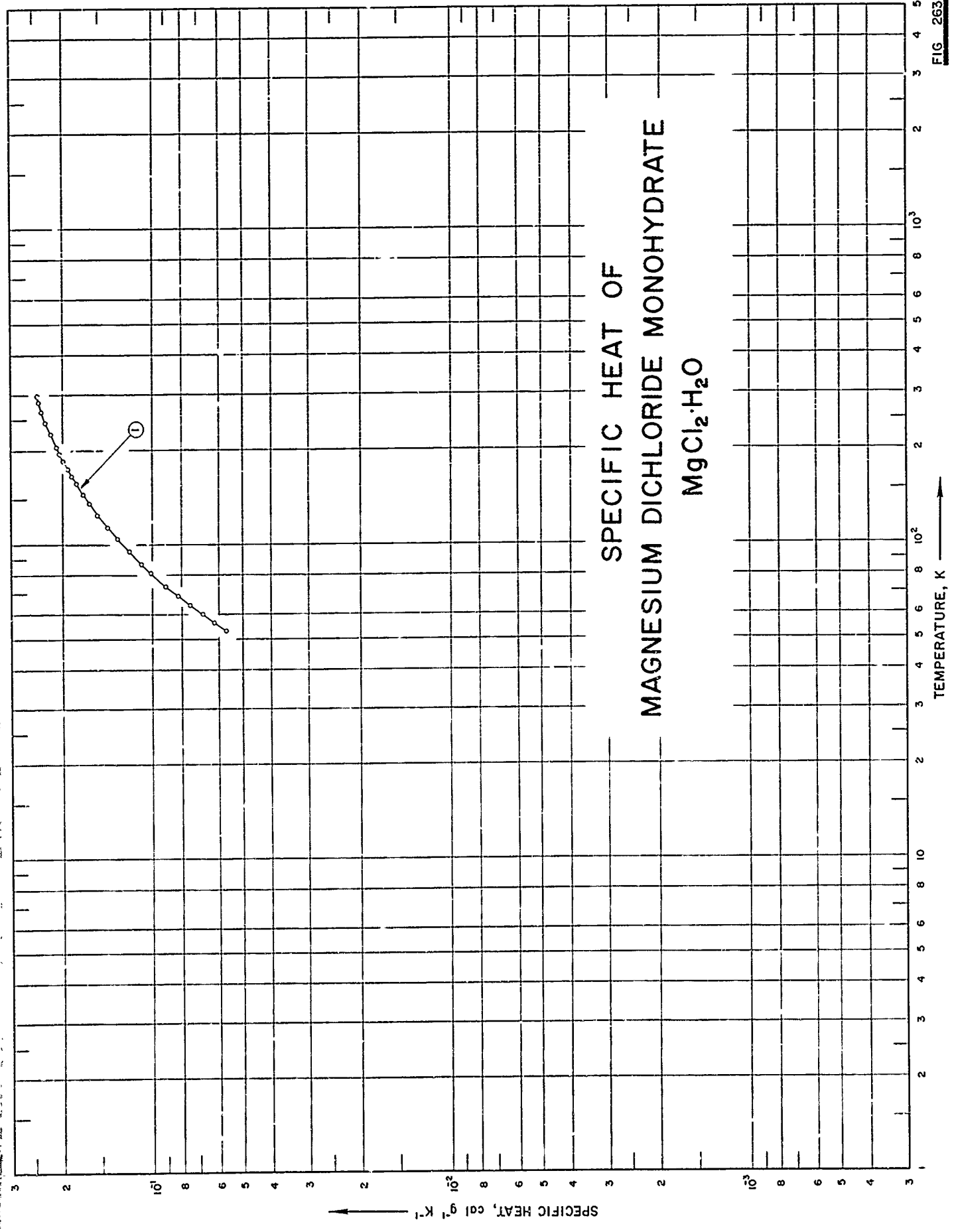

SPECIFICATION TABLE NO. 263 SPECIFIC HEAT OF MAGNESIUM DICHLORIDE MONOHYDRATE $MgCl_2 \cdot H_2O$

[For Data Reported in Figure and Table No. 263]

Curve No.	Ref. No.	Year	Temp. Range, K	Reported Error, %	Name and Specimen Designation	Composition (weight percent), Specifications and Remarks
1	323	1943	54-298			62.44 Cl (62.62 theo), 21.57 Mg (21.47 theo), and 0.14 MgO; prepared from stoichiometric quantities of dehydrated and anhydrous magnesium chloride; heated 16 hrs at 120-140 C under vacuum. (corrected for MgO impurities)

DATA TABLE NO. 263 SPECIFIC HEAT OF MAGNESIUM DICHLORIDE MONOHYDRATE $\text{MgCl}_2 \cdot \text{H}_2\text{O}$
 [Temperature, T, K; Specific Heat, Cp, Cal g⁻¹°K⁻¹]

T	Cp
	5.697×10^{-2}
53.5	6.241
56.9	6.808
60.5	7.497
64.6	8.227
69.1	9.024
74.1	1.009 x 10 ^{-1*}
81.7	1.011
81.9	1.079*
86.7	1.082
87.0	1.198
95.7	1.310
105.3	1.418
114.8	1.531
125.6	1.626
135.7	1.708
145.7	1.800
157.2	1.863
166.0	1.923
175.8	1.986
185.6	2.050
196.3	2.094
206.0	2.144*
216.4	2.192
226.3	2.234*
236.3	2.274
246.2	2.312*
256.3	2.352
266.4	2.388*
275.9	2.408
285.9	2.429*
295.7	2.426
298.2	

* Not shown on plot

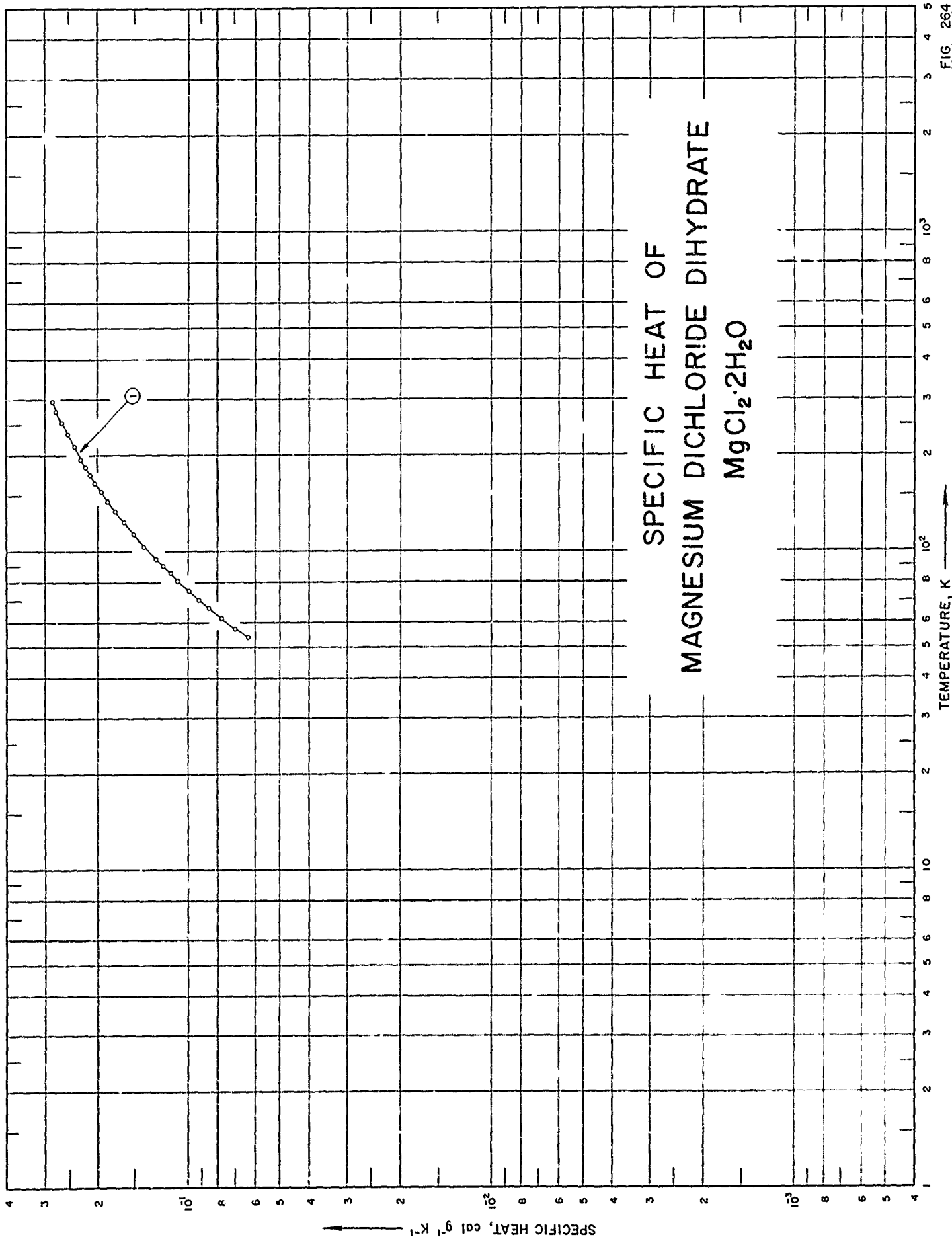

FIG. 264

SPECIFICATION TABLE NO. 264 SPECIFIC HEAT OF MAGNESIUM DICHLORIDE DIHYDRATE $MgCl_2 \cdot 2H_2O$

[For Data Reported in Figure and Table No. 264]

Curve No.	Ref. No.	Year	Temp. Range, K	Reported Error, %	Name and Specimen Designation	Composition (weight percent), Specifications and Remarks
1	323	1943	54-295			54.04 Cl (54.03 theo), 18.62 Mg (18.53 theo), and 0.01 MgO; prepared from tetrahydrate by heating in a stream of dry HCl at temperatures gradually increasing from 170-220 C until the required amount of water was removed; aged for 7 hrs at 103 C.

DATA TABLE NO. 264 SPECIFIC HEAT OF MAGNESIUM DICHLORIDE DIHYDRATE $\text{MgCl}_2 \cdot 2\text{H}_2\text{O}$ [Temperature, T, K; Specific Heat, Cp, Cal g⁻¹K⁻¹]

T	Cp
<u>CURVE 1</u>	
54.1	6.491×10^{-2}
57.6	7.117
62.1	7.907
66.8	8.783
70.8	9.423
75.1	1.011×10^{-1}
81.2	1.100
85.6	1.166
90.2	1.236
94.9	1.301
104.7	1.430
114.4	1.550
124.7	1.676
134.8	1.787
145.3	1.892
155.2	1.988
165.6	2.084
175.4	2.163
185.7	2.244
195.9	2.324
206.1	2.390*
215.9	2.449
225.8	2.515*
236.2	2.576
246.2	2.643*
256.2	2.696
266.3	2.752*
276.3	2.806
285.7	2.849*
295.0	2.887

* Not shown on plot

SPECIFIC HEAT OF
MAGNESIUM DICHLORIDE TETRAHYDRATE
 $MgCl_2 \cdot 4H_2O$

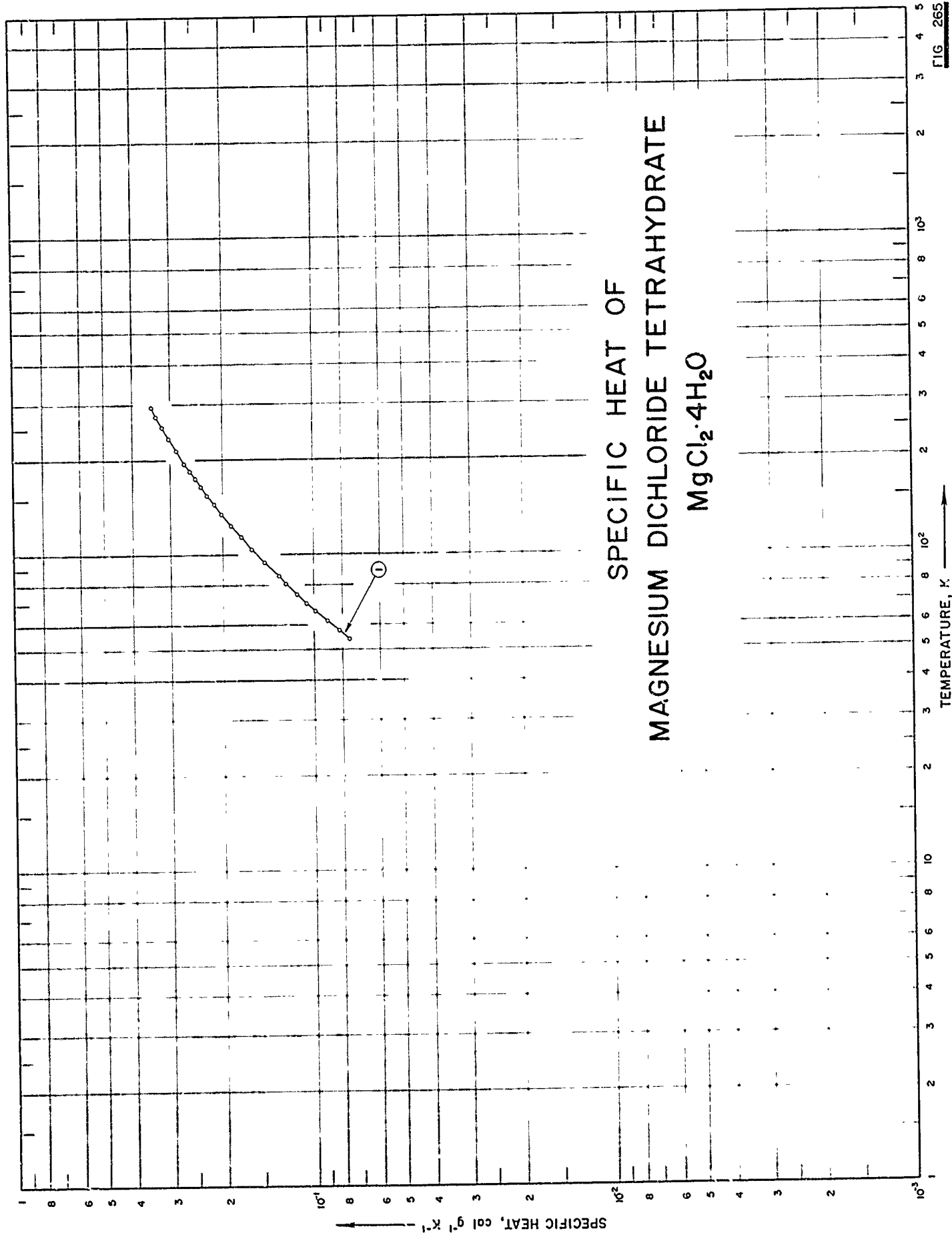

SPECIFICATION TABLE NO. 265 SPECIFIC HEAT OF MAGNESIUM DICHLORIDE TETRAHYDRATE $\text{MgCl}_2 \cdot 4\text{H}_2\text{O}$

[For Data Reported in Figure and Table No. 265]

Curve No.	Ref. No.	Year	Temp. Range, K	Reported Error, %	Name and Specimen Designation	Composition (weight percent), Specifications and Remarks
1	323	1943	54-296			42.39 Cl (42.39 theo), 14.61 Mg (14.54 theo), and 0.012 MgO; prepared from hexahydrate by heating in air at 100-103 C for 6 days.

DATA TABLE NO. 265 SPECIFIC HEAT OF MAGNESIUM DICHLORIDE TETRAHYDRATE $\text{MgCl}_2 \cdot 4\text{H}_2\text{O}$ [Temperature, T, K; Specific Heat, Cp, Cal g⁻¹K⁻¹]

T	Cp
<u>CURVE 1</u>	
54.1	7.585×10^{-2}
57.5	8.185
61.8	8.995
66.4	9.892
70.3	1.060×10^{-1}
74.9	1.139
81.0	1.237
85.7	1.303
94.5	1.450
104.5	1.595
114.2	1.733
124.6	1.874
135.2	2.012
145.1	2.132
155.6	2.252
165.3	2.363
175.6	2.467
185.4	2.567
196.0	2.674
205.8	2.757*
216.0	2.846
225.9	2.930*
236.4	3.013
246.1	3.093*
255.9	3.167
265.9	3.245*
276.0	3.320
385.7	3.38f*
295.5	3.433

* Not shown on plot

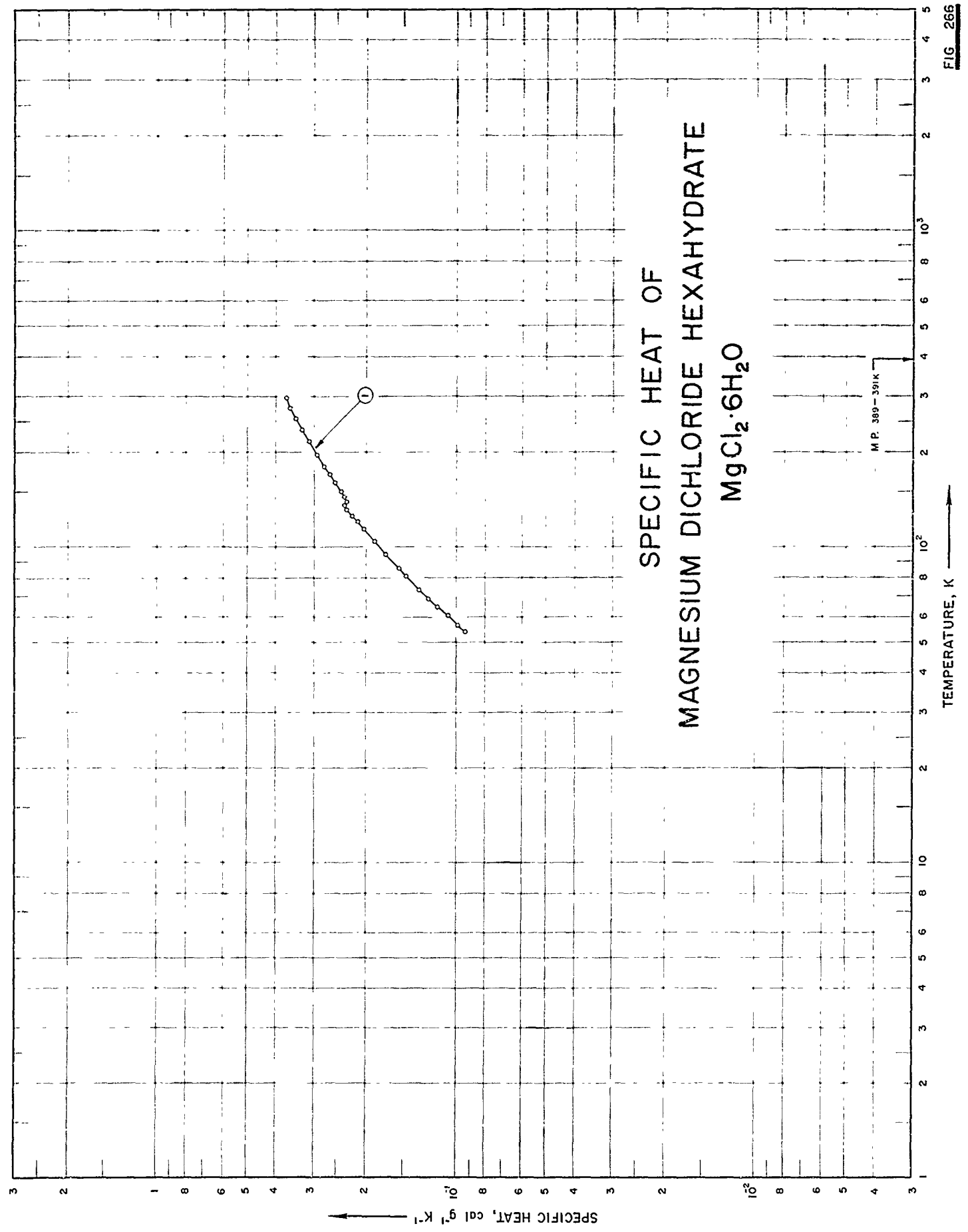

FIG. 266

SPECIFICATION TABLE NO. 266 SPECIFIC HEAT OF MAGNESIUM DICHLORIDE HEXAHYDRATE $MgCl_2 \cdot 6H_2O$

[For Data Reported in Figure and Table No. 266]

Curve No.	Ref. No.	Year	Temp. Range, K	Reported Error, %	Name and Specimen Designation	Composition (weight percent), Specifications and Remarks
1	323	1943	54-296			Meck's reagent grade; 34.81 Cl (34.88 theo), and 12.05 Mg (11.96 theo); stored over 80% H_2SO_4 for seven days at room temperature.

DATA TABLE NO. 266 SPECIFIC HEAT OF MAGNESIUM DICHLORIDE HEXAHYDRATE $\text{MgCl}_2 \cdot 6\text{H}_2\text{O}$ [Temperature, T, K; Specific Heat, Cp, Cal g⁻¹K⁻¹]

T	Cp	T	Cp
CURVE 1		CURVE 1 (cont.)	
54.10	9.295 x 10 ⁻²	216.10	3.098 x 10 ⁻¹
56.90	9.880	226.10	3.179*
60.60	1.065 x 10 ⁻¹	235.90	3.265
64.70	1.156	245.80	3.352*
68.60	1.237	255.50	3.439
73.10	1.327	265.90	3.502*
80.90	1.470	276.20	3.582
80.90	1.471*	285.80	3.635*
85.20	1.549	295.80	3.696
94.70	1.718		
104.30	1.876		
104.40	1.876*		
114.10	2.032		
115.00	2.046*		
117.40	2.087*		
120.70	2.138		
123.80	2.189*		
124.40	2.196*		
126.40	2.227		
128.30	2.256*		
130.00	2.285		
132.20	2.311		
134.00	2.338*		
134.90	2.341*		
135.90	2.354		
137.60	2.354*		
139.40	2.324		
141.20	2.327*		
142.90	2.343*		
144.60	2.361		
145.50	2.373*		
146.20	2.380*		
147.80	2.400*		
149.40	2.416		
151.00	2.437*		
155.30	2.484*		
159.00	2.533		
165.70	2.607*		
169.60	2.648		
175.50	2.708*		
179.70	2.766		
185.80	2.822*		
195.90	2.921		
205.70	3.005*		

* Not shown on plot

SPECIFIC HEAT OF MANGANESE DICHLORIDE MnCl2

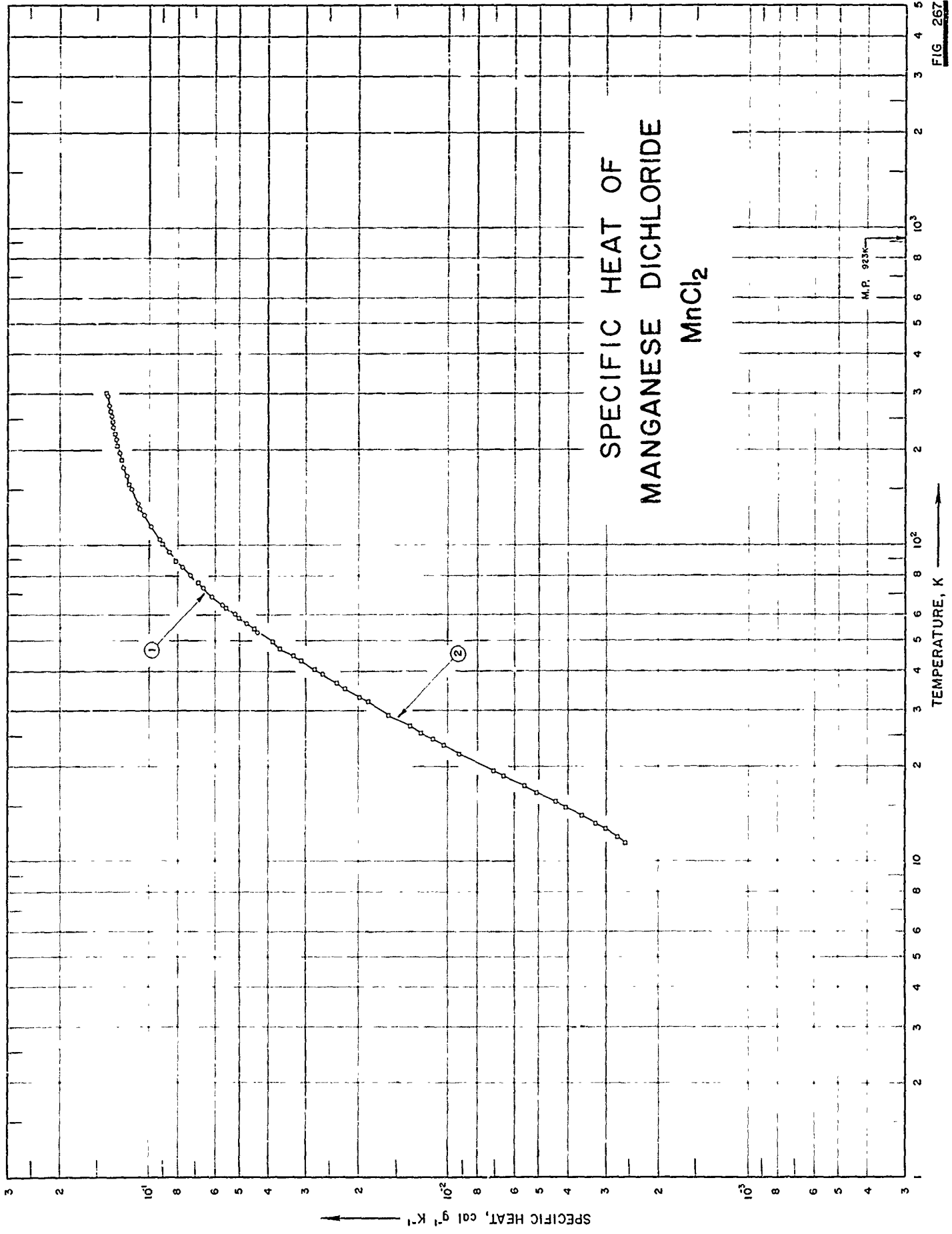

SPECIFIC HEAT, cal g⁻¹ K⁻¹

TEMPERATURE, K

SPECIFICATION TABLE NO. 267 SPECIFIC HEAT OF MANGANESE DICHLORIDE $MnCl_2$

[For Data Reported in Figure and Table No. 267]

Curve No.	Ref. No.	Year	Temp. Range, K	Reported Error, %	Name and Specimen Designation	Composition (weight percent), Specifications and Remarks
1	250	1943	53-295			56.30 Cl (56.35 theo), and 43.42 Mn (43.65 theo) ; prepared from $MnCl_2 \cdot 4H_2O$ by heating in vacuum to 200 C; temp raised slowly to avoid fusion; dehydration completed by passing dry HCl at 620.
2	324	1962	11-300			56.35 Cl (56.35 theo), 43.71 Mn (43.65 theo), 0.001 Si, Fe, Cu, and Ag; prepared from analytical reagent $MnCl_2 \cdot 4H_2O$; heated with HCl stream at 780-800 C.

DATA TABLE NO. 267 SPECIFIC HEAT OF MANGANESE DICHLORIDE MnCl₂[Temperature, T, K; Specific Heat, Cp, Cal g⁻¹K⁻¹]

CURVE 1		CURVE 2 (cont.)		CURVE 2 (cont.)	
T	Cp	T	Cp	T	Cp
53.1	4.388 x 10 ⁻²	105.77	9.409 x 10 ⁻² *	Series II	
56.6	4.758	111.39	9.750*	11.97	2.749 x 10 ⁻²
60.5	5.211	116.49	1.004 x 10 ⁻¹ *	13.19	3.234
64.8	5.721	121.33	1.031*	14.77	4.069
68.8	6.186	125.88	1.055*	16.49	5.102
73.0	6.635	130.35	1.078	18.57	6.564
80.4	7.350	134.41	1.095*	21.87	9.242
85.2	7.784	138.92	1.115*	24.28	1.135 x 10 ⁻²
95.2	8.622	142.68	1.127*	26.72	1.360
104.8	9.298	147.53	1.146*	28.97	1.581
115.2	9.941	151.57	1.161*	31.82	1.869
124.9	1.048 x 10 ⁻¹	156.02	1.173	32.98	1.991
135.5	1.097	159.33	1.185*	36.50	2.367
150.6	1.152	163.34	1.197*	40.45	2.815
156.0	1.171*	167.40	1.208*	44.74	3.327
165.9	1.200	171.07	1.216*	49.34	3.880
176.1	1.223	174.87	1.227*	53.78	4.417*
186.1	1.247*	178.63	1.236*	Series III	
195.6	1.268	181.73	1.244*	11.48	2.595 x 10 ⁻³
205.8	1.283	186.02	1.252	12.66	3.004
215.5	1.299	190.18	1.263*	13.96	3.508
225.8	1.314*	193.96	1.267*	15.41	4.394
235.9	1.325	197.92	1.276*	17.27	5.618
245.8	1.338*	201.78	1.281*	19.30	7.120
256.1	1.349	205.27	1.289	Series IV	
266.0	1.358*	208.99	1.291*	21.38	8.813 x 10 ⁻³ *
276.0	1.370	212.26	1.297*	23.29	1.047 x 10 ⁻²
285.7	1.378*	216.28	1.305*	25.44	1.242
295.0	1.381	220.51	1.309*	31.76	1.861*
		224.66	1.317	35.11	2.223
		228.57	1.320*	38.91	2.649
		232.59	1.325*	43.10	3.131
		236.51	1.331*	47.67	3.677
		241.36	1.333*	Series V	
		246.10	1.341	299.03	1.388 x 10 ⁻¹ *
		252.22	1.346*		
		258.28	1.353*		
		264.86	1.359		
		271.25	1.367*		
		277.49	1.371*		
		282.23	1.372*		
		288.38	1.376*		
		294.39	1.385*		
		300.04	1.384*		
		306.07	1.393		

* Not shown on plot

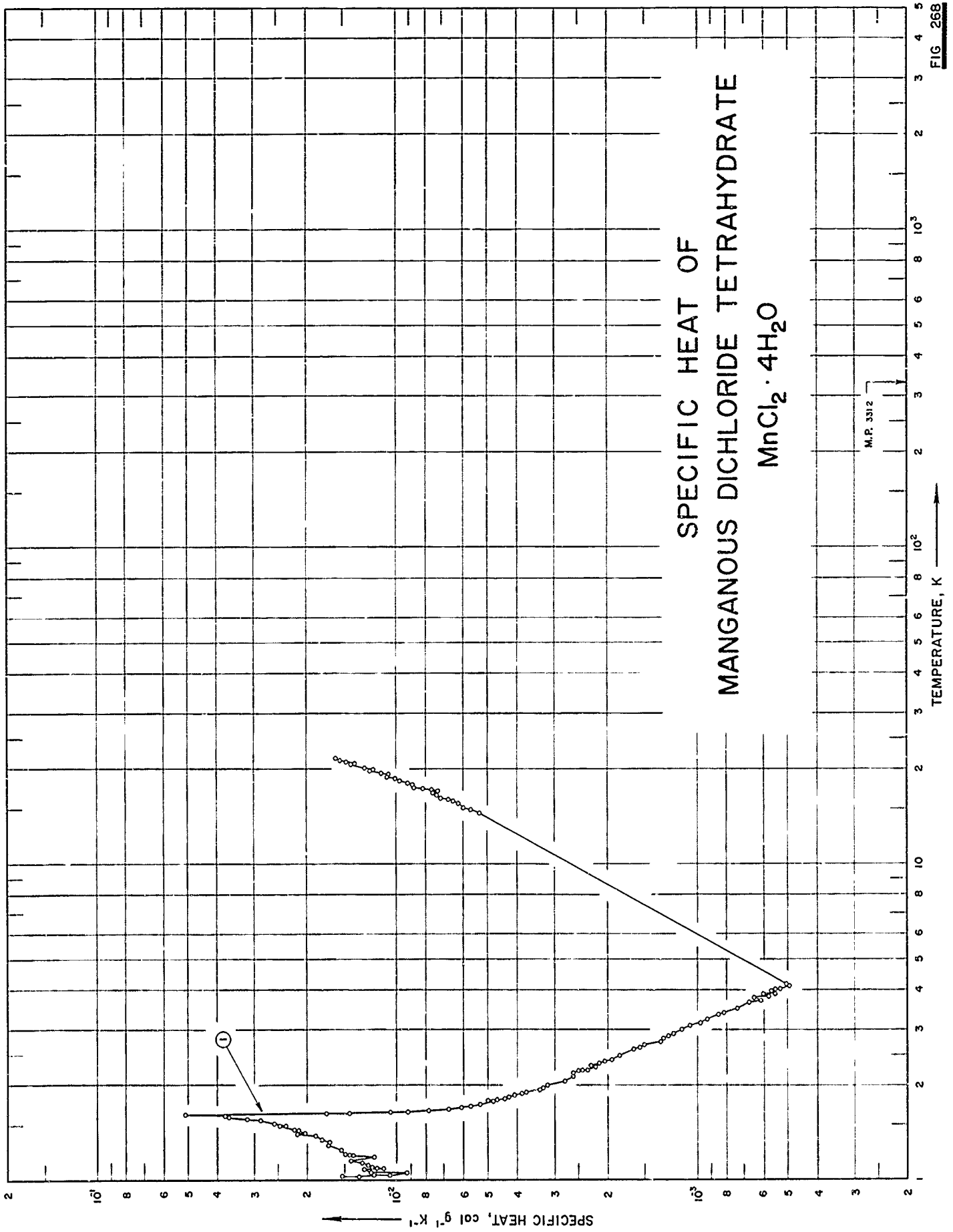

FIG. 268

SPECIFICATION TABLE NO. 268 SPECIFIC HEAT OF MANGANOUS DICHLORIDE TETRAHYDRATE $MnCl_2 \cdot 4H_2O$

[For Data Reported in Figure and Table No. 268]

Curve No.	Ref. No.	Year	Temp. Range, K	Reported Error, %	Name and Specimen Designation	Composition (weight percent), Specifications and Remarks
1	262	1953	1-22			99.8 $MnCl_2 \cdot 4H_2O$; sample supplied by Hopkins and William Ltd. ; measured under 10^{-4} mole of He gas.

DATA TABLE NO. 268 SPECIFIC HEAT OF MANGANESE DICHLORIDE TETRAHYDRATE $MnCl_2 \cdot 4H_2O$ [Temperature, T, K; Specific Heat, Cp, Cal g⁻¹K⁻¹]

CURVE I		CURVE I (cont.)		CURVE I (cont.)		CURVE I (cont.)		CURVE I (cont.)		CURVE I (cont.)	
T	Cp	T	Cp	T	Cp	T	Cp	T	Cp	T	Cp
Series I											
1.026	1.53 x 10 ²	1.203	1.45*	1.581	3.23 x 10 ⁻² *	2.820	1.30 x 10 ⁻³	2.540	1.69 x 10 ⁻³	21.26	1.50 x 10 ⁻² *
1.033	1.34	1.243	1.55*	1.587	3.66	2.871	1.25	2.560	1.67	21.39	1.56
1.044	1.06	1.296	1.62*	1.594	3.43*	2.915	1.20*	3.43*	8.15 x 10 ⁻⁴	21.54	1.58*
1.059	9.29 x 10 ⁻³	1.321	1.68	1.600	3.76	2.946	1.20*	3.44*	8.21	21.67	1.59
1.069	1.23 x 10 ²	1.353	1.80*	1.605	4.32*	2.987	1.13	3.44*	8.21	Series VII*	
1.079	1.22*	1.390	1.87*	1.610	4.37*	3.033	1.11*	4.025	5.86	14.53	5.63 x 10 ⁻³
1.089	1.29*	1.421	2.07*	1.615	4.84*	3.065	1.06*	4.070	5.25	15.91	6.04
1.099	1.29	1.454	2.21	1.620	5.13	3.085	1.06	Series VI		15.39	6.38
1.103	1.17	1.482	2.48	1.629	1.73	3.120	1.04*	14.54	5.37 x 10 ⁻³	15.90	6.75
1.103	1.22	1.523	2.57	1.646	1.05	3.152	9.84 x 10 ⁻⁴	14.85	5.71	16.38	7.60
1.121	1.23*	1.553	2.86	1.654	9.18 x 10 ⁻³ *	3.191	9.57*	15.16	6.01	16.87	8.16
1.138	1.32	1.573	3.18	1.687	6.94*	3.214	9.60*	15.41	6.11*	17.28	8.33
1.178	1.21	1.608	3.39*	1.743	5.47*	3.230	9.30	15.56	6.28	17.46	9.01
1.219	1.50	1.631	1.45	1.797	4.66	3.269	8.85*	15.70	6.38*	17.58	8.86
1.254	1.55	1.650	9.20 x 10 ⁻³	1.836	4.13*	3.316	8.72*	16.04	6.78	18.02	9.92
1.289	1.70	1.666	7.87	1.887	3.77*	3.354	8.51	16.23	7.17	18.27	9.79
1.323	1.73*	1.684	6.75	1.938	3.33*	3.385	8.19	16.62	7.43	18.51	1.09
1.351	1.79	1.702	6.11	1.983	3.07*	3.513	7.36	16.83	7.60	18.71	1.26
1.379	1.88	1.724	5.72	2.047	2.78*	3.545	7.05*	17.02	7.32	18.98	1.09
1.408	2.03	1.742	5.30	2.101	2.65*	3.653	6.76	17.27	7.67	19.46	1.20
1.439	2.14	1.780	4.81	2.161	2.42*	3.700	6.16	17.40	8.22	19.53	1.26
1.478	2.37	1.817	4.40	2.225	2.25*	3.744	6.40	17.58	8.83	19.72	1.24
1.486	5.00 x 10 ⁻³	1.876	3.82	2.262	2.25*	3.816	5.82	18.02	9.20	20.20	1.34
1.868	4.28	1.937	3.37	Series IV		3.840	5.91*	18.16	9.18*	20.40	1.30
1.869	4.08	2.004	3.15*	2.232	2.50 x 10 ⁻³	3.866	5.91*	18.31	9.29*	20.66	1.46
1.896	3.73	2.063	2.78	2.262	2.33*	3.890	6.05	18.45	9.78	20.85	1.47
1.928	3.68*	2.230	2.32	2.285	2.26*	3.914	5.53	18.59	9.73*	21.08	1.47
1.964	3.27	2.408	1.93	2.305	2.27	3.960	5.70	18.75	1.01 x 10 ⁻²	21.40	1.59
2.003	3.18	2.484	1.82	2.326	2.22*	4.040	5.31	19.13	1.08*	21.69	1.47
2.127	2.61	Series III		2.327	2.20*	4.060	5.30*	19.32	1.07	21.93	1.80
2.179	2.61	1.042	1.09 x 10 ⁻² *	2.356	2.14*	4.119	4.98	19.49	1.14	Series V*	
2.231	2.43	1.079	1.11	2.390	2.04	4.180	5.08	19.66	1.20*	19.83	1.23
2.278	2.19	1.113	1.26	2.421	2.03*	Series V*		19.99	1.21	20.15	1.28
1.043	1.22 x 10 ²	1.155	1.29*	2.421	2.03*	1.765	4.81 x 10 ⁻³	20.73	1.43	20.87	1.39
1.052	1.38*	1.199	1.41	2.498	1.83	1.815	2.25	21.01	1.45*	21.14	1.49
1.061	1.29*	1.241	1.51*	2.598	1.63	2.340	2.15				
1.066	1.17*	1.404	2.15	2.644	1.56	1.785	4.34				
1.091	1.26*	1.436	2.23*	2.681	1.51	1.810	4.24				
1.100	1.29*	1.471	2.40*	2.688	1.50*	1.875	3.96				
1.127	1.34*	1.508	2.62*	2.708	1.47*	1.875	2.25				
1.161	1.44	1.545	2.81*	2.719	1.39*	1.875	2.25				
		1.568	3.14*	2.747	1.33	2.225	2.25				
		1.575	3.39*	2.785	1.40*	2.340	2.15				

* Not shown on plot

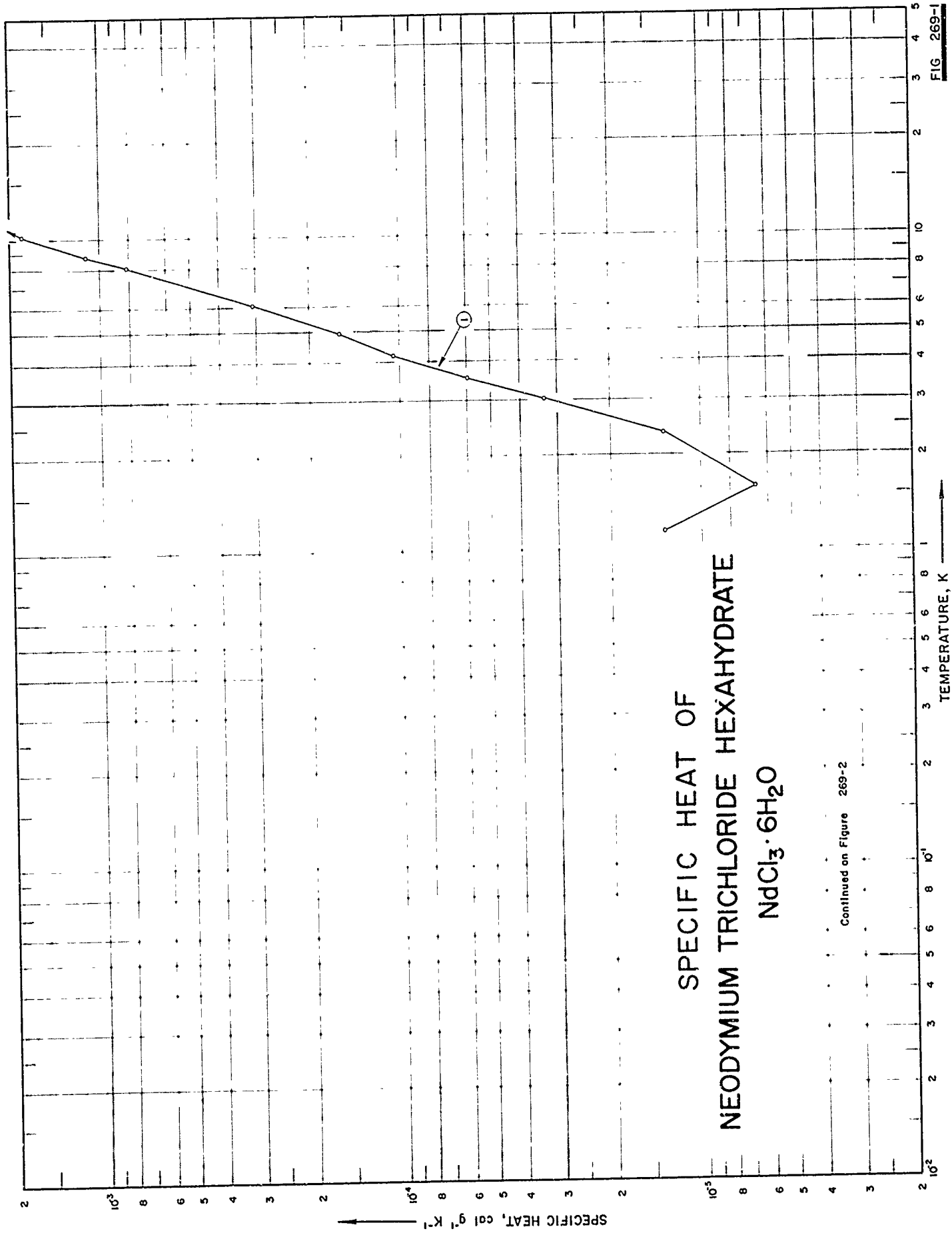

FIG. 269-1

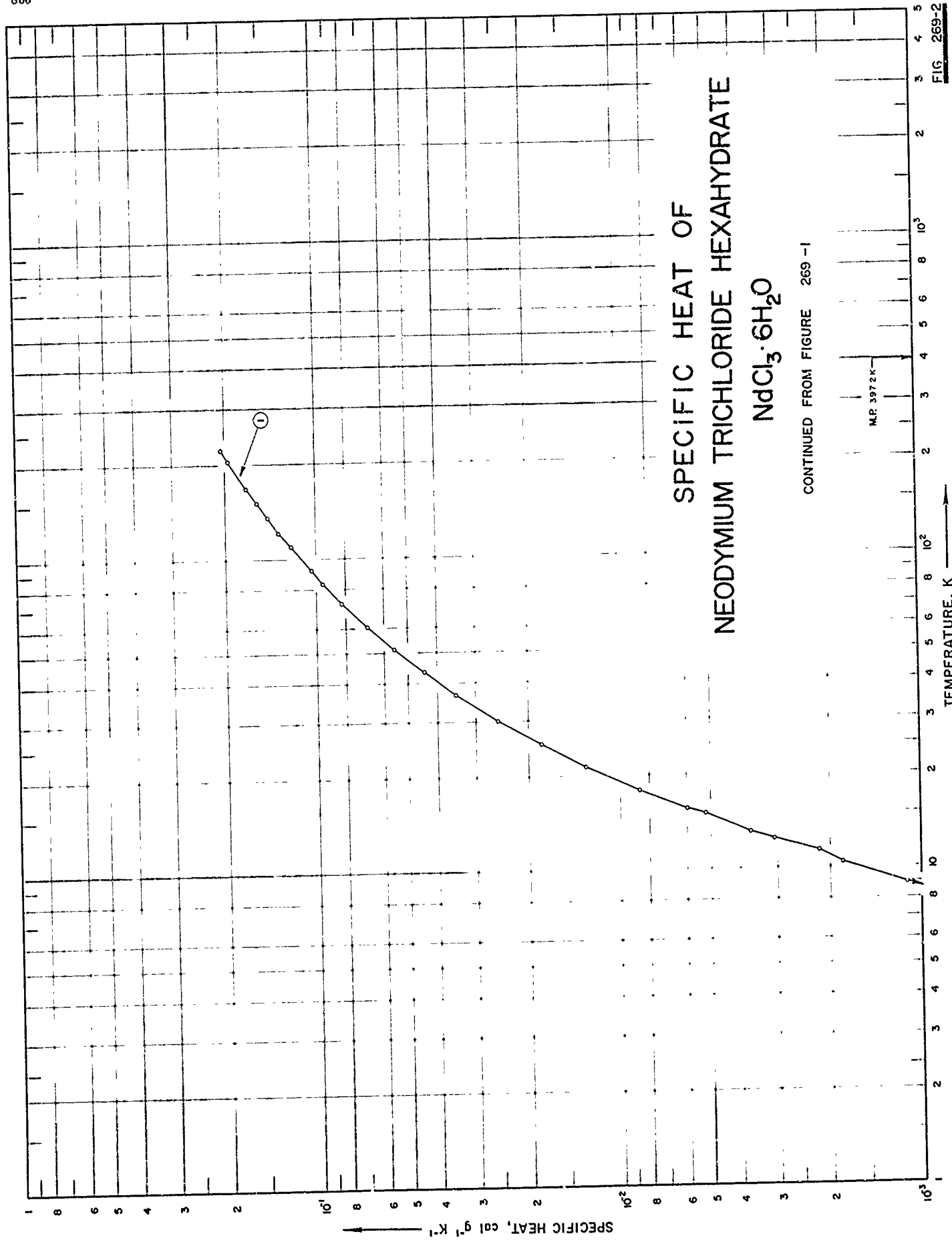

FIG. 269-2

SPECIFICATION TABLE NO. 269 SPECIFIC HEAT OF NEODYMIUM TRICHLORIDE HEXAHYDRATE $\text{NdCl}_3 \cdot 6\text{H}_2\text{O}$

[For Data Reported in Figure and Table No. 269]

Curve No.	Ref. No.	Year	Temp. Range, K	Reported Error, %	Name and Specimen Designation	Composition (weight percent), Specifications and Remarks
1	319	1961	1.2-223			

DATA TABLE NO. 269 SPECIFIC HEAT OF NEODYMIUM TRICHLORIDE HEXAHYDRATE $\text{NdCl}_3 \cdot 6\text{H}_2\text{O}$ [Temperature, T, K; Specific Heat, Cp, Cal g⁻¹K⁻¹]

T	Cp
1.16	1.333×10^5
1.58	6.663×10^6
2.37	1.333×10^5
3.05	3.332
3.56	5.997
4.24	1.066×10^4
4.64	1.266
4.98	1.599
6.18	3.198
8.21	8.196
8.94	1.119×10^3
10.42	1.826
11.14	2.186
12.45	3.078
13.17	3.685
15.02	5.211
15.68	5.977
17.95	8.609
18.25	9.015*
21.37	1.299×10^2
21.55	1.317*
25.34	1.818
25.35	1.821*
30.18	2.823
30.36	2.557*
36.59	3.448
43.40	4.452
51.35	5.578
60.93	6.837
72.00	8.269
83.5	9.515
92.36	1.043×10^{-1}
109.73	1.221
122.47	1.832
136.37	1.450
151.72	1.572
168.84	1.703
205.12	1.957
205.13	1.952*
221.52	2.053*
223.37	2.065

* Not shown on plot

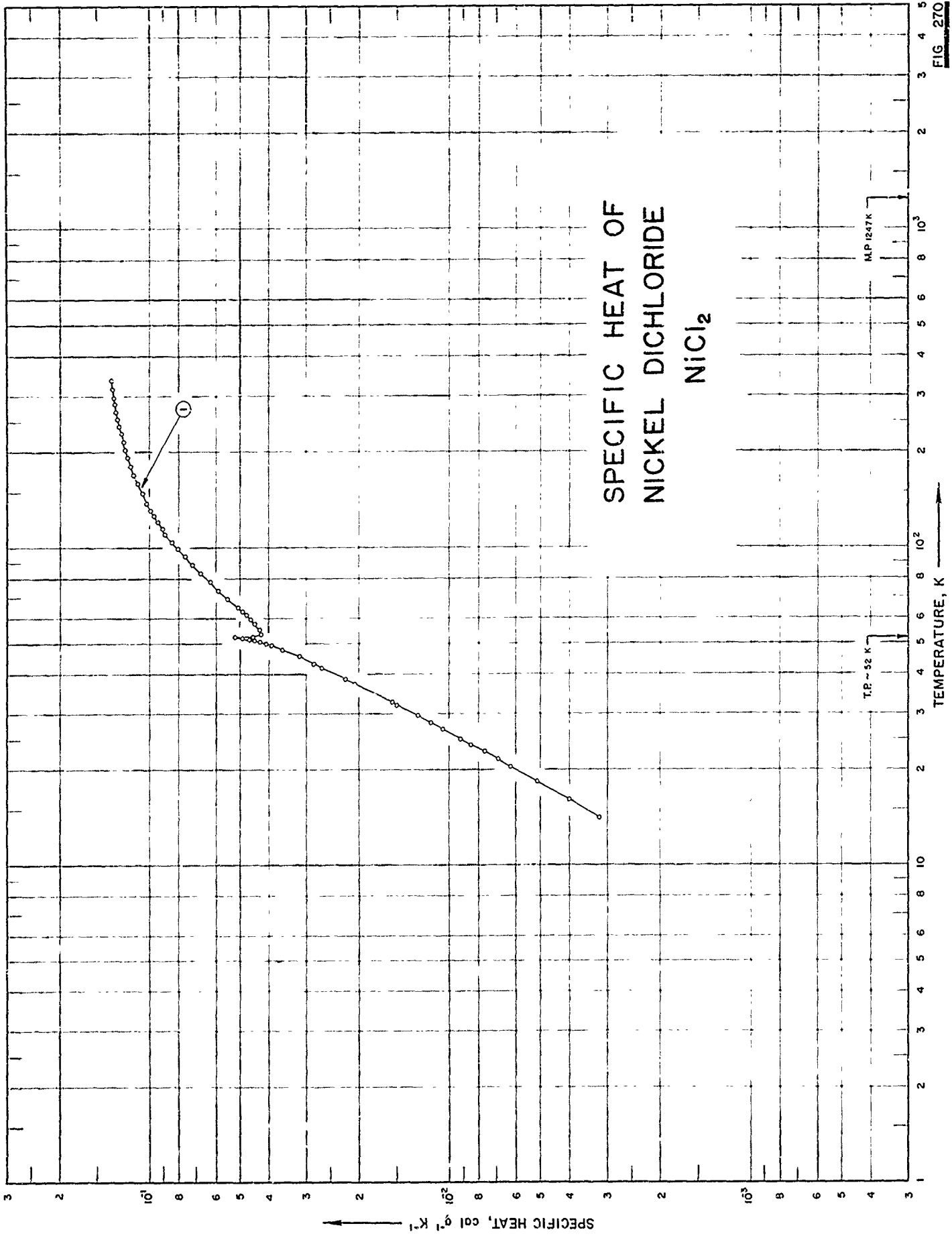

SPECIFICATION TABLE NO. 270 SPECIFIC HEAT OF NICKEL DICHLORIDE NiCl_2

[For Data Reported in Figure and Table No. 270]

Curve No.	Ref. No.	Year	Temp. Range, K	Reported Error, %	Name and Specimen Designation	Composition (weight percent), Specifications and Remarks
1	264	1952	15-300	1.0-5		54.715 Cl_2 (54.716 theo), 45.29 Ni (45.284 theo); density = 3.54 g ml^{-1} .

DATA TABLE NO. 270 SPECIFIC HEAT OF NICKEL DICHLORIDE NiCl_2
 [Temperature, T, K; Specific Heat Cp, Cal $\text{g}^{-1}\text{K}^{-1}$]

T	Cp	T	Cp	T	Cp
CURVE 1		CURVE 1 (cont.)		CURVE 1 (cont.)	
Series A					
272.60	1.298 x 10 ^{-8*}	204.05	1.205 x 10 ⁻¹	Series E	
280.47	1.306*	216.40	1.215*	57.02	4.405 x 10 ^{-2*}
288.40	1.312*	222.94	1.237*	59.60	4.600*
296.84	1.321	229.28	1.245	62.16	4.816*
305.90	1.328*	235.42	1.255*	Series F	
315.87	1.333	241.76	1.262	20.57	6.473 x 10 ^{-3*}
325.62	1.347*	248.13	1.272*	22.35	7.530*
336.36	1.349	254.41	1.278	24.93	9.282
Series B					
79.91	6.558 x 10 ^{-2*}	260.89	1.286*	28.07	1.169 x 10 ⁻²
84.56	6.882*	268.00	1.293	32.19	1.526*
Series C					
Series D		275.23	1.300*	38.24	2.184*
Series E		283.07	1.307	42.45	2.727*
Series F		Series G			
14.14	3.217 x 10 ⁻³	14.14	3.217 x 10 ⁻³	21.56	6.975 x 10 ⁻³
16.03	4.019	16.03	4.019	24.16	8.726*
18.34	5.154	18.34	5.154	27.61	1.126 x 10 ^{-2*}
20.47	6.343	20.47	6.343	31.89	1.503
22.72	7.715	22.72	7.715	37.22	2.070
23.90	8.525	23.90	8.525	43.15	2.854
26.80	1.287	26.80	1.287	47.54	3.577*
29.56	1.562	29.56	1.562	51.45	4.610*
32.57	2.225	32.57	2.225	51.62	4.670
38.51	2.678	38.51	2.678	51.77	4.740*
41.92	3.941	41.92	3.941	51.94	4.815*
45.35	3.183	45.35	3.183	52.04	4.913
47.85	3.639	47.85	3.639	52.19	5.013*
49.27	4.109	49.27	4.109	52.32	5.198
50.58	4.282	50.58	4.282	52.45	4.955*
51.20	4.482	51.20	4.482	52.59	4.535
55.36	4.304	55.36	4.304	52.96	4.333*
56.22	4.394*	56.22	4.394*	53.56	4.264
57.28	4.414*	57.28	4.414*	54.15	4.268*
57.83	4.479	57.83	4.479	54.73	4.286*
58.35	4.510*	58.35	4.510*	55.79	4.330*
58.90	4.556*	58.90	4.556*	58.22	4.497*
59.42	4.593*	59.42	4.593*	61.62	4.778
59.93	4.623	59.93	4.623		
60.44	4.658*	60.44	4.658*		
60.94	4.718*	60.94	4.718*		
61.43	4.766*	61.43	4.766*		
63.15	4.901	63.15	4.901		

* Not shown on plot

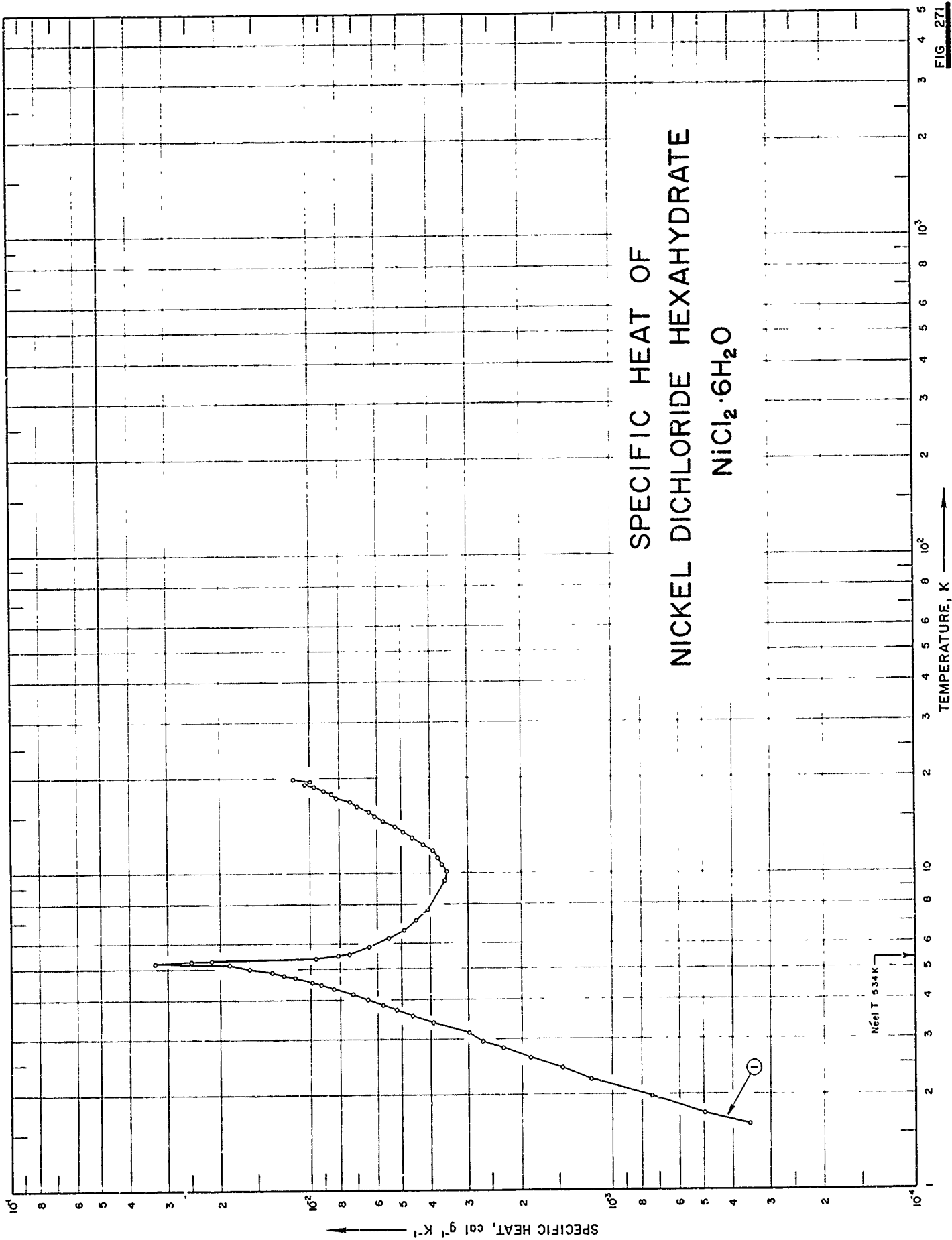

SPECIFICATION TABLE NO. 271 SPECIFIC HEAT OF NICKEL DICHLORIDE HEXAHYDRATE $\text{NiCl}_2 \cdot 6\text{H}_2\text{O}$

[For Data Reported in Figure and Table No. 271]

Curve No.	Ref. No.	Year	Temp. Range, K	Reported Error, %	Name and Specimen Designation	Composition (weight percent), Specifications and Remarks
1	256	1959	1.6-20			0.08 alkalis and earth, 0.01 Zn, 0.009 Co, and insoluble, 0.006 nitrogen compounds, 0.005 Pb, 0.001 Cu, 0.0007 Fe and 0.0004 sulfate.

DATA TABLE NO. 271 SPECIFIC HEAT OF NICKEL DICHLORIDE HEXAHYDRATE $\text{NiCl}_2 \cdot 6\text{H}_2\text{O}$
 [Temperature, T, K; Specific Heat, Cp, Cal $\text{g}^{-1}\text{K}^{-1}$]

T	Cp	T	Cp
CURVE I		CURVE I (cont.)	
Series I			
1.6104	3.542×10^{-4}	5.5826	7.476×10^{-3}
1.7412	4.981	5.8208	6.500*
1.9740	7.434	6.1765	5.675*
2.2363	1.186×10^{-3}	6.6360	5.074*
2.4239	-1.472	7.1344	4.472
2.6182	1.879	7.6764	4.085
2.8012	2.311	10.1090	3.542
2.9495	2.683	10.6880	3.668
3.1500	2.998	11.2590	3.799
3.3805	3.324	11.8050	3.912
3.5624	4.619	12.3580	4.249
3.7186	5.221	12.9580	4.586
3.8587	5.772	13.5640	4.922
4.0222	6.491	14.1260	5.259
4.1842	7.286	14.6440	5.721
4.3488	8.448	15.1720	6.100
4.4688	9.222	15.7120	6.395
4.5520	9.895	16.2690	6.984
4.6108	1.032×10^{-2} *	16.8420	7.362
4.7348	1.138	17.3720	8.204
4.7550	1.179*	17.8640	8.540
4.7740	1.184*	18.3330	9.003
4.7998	1.244	18.7740	9.718
4.8472	1.274*	19.1840	1.048×10^{-2}
4.9088	1.354	19.5880	9.970×10^{-3}
4.9848	1.437*	19.9760	1.140×10^{-2}
5.0743	1.603		
5.1828	1.873		
5.3095	2.154		
5.5198	8.145×10^{-3}		
5.8648	6.411		
6.2788	5.503		
6.6268	4.914		
Series II			
4.6444	1.062×10^{-2} *		
4.7041	1.126*		
4.7918	1.203*		
4.9148	1.565*		
5.0452	1.525*		
5.1764	1.836*		
5.2652	3.300		
5.3122	2.504		
5.4142	9.647×10^{-3}		

* Not shown on plot

FIG 272

SPECIFIC HEAT OF PHOSPHOROUS TRICHLORIDE PCl3

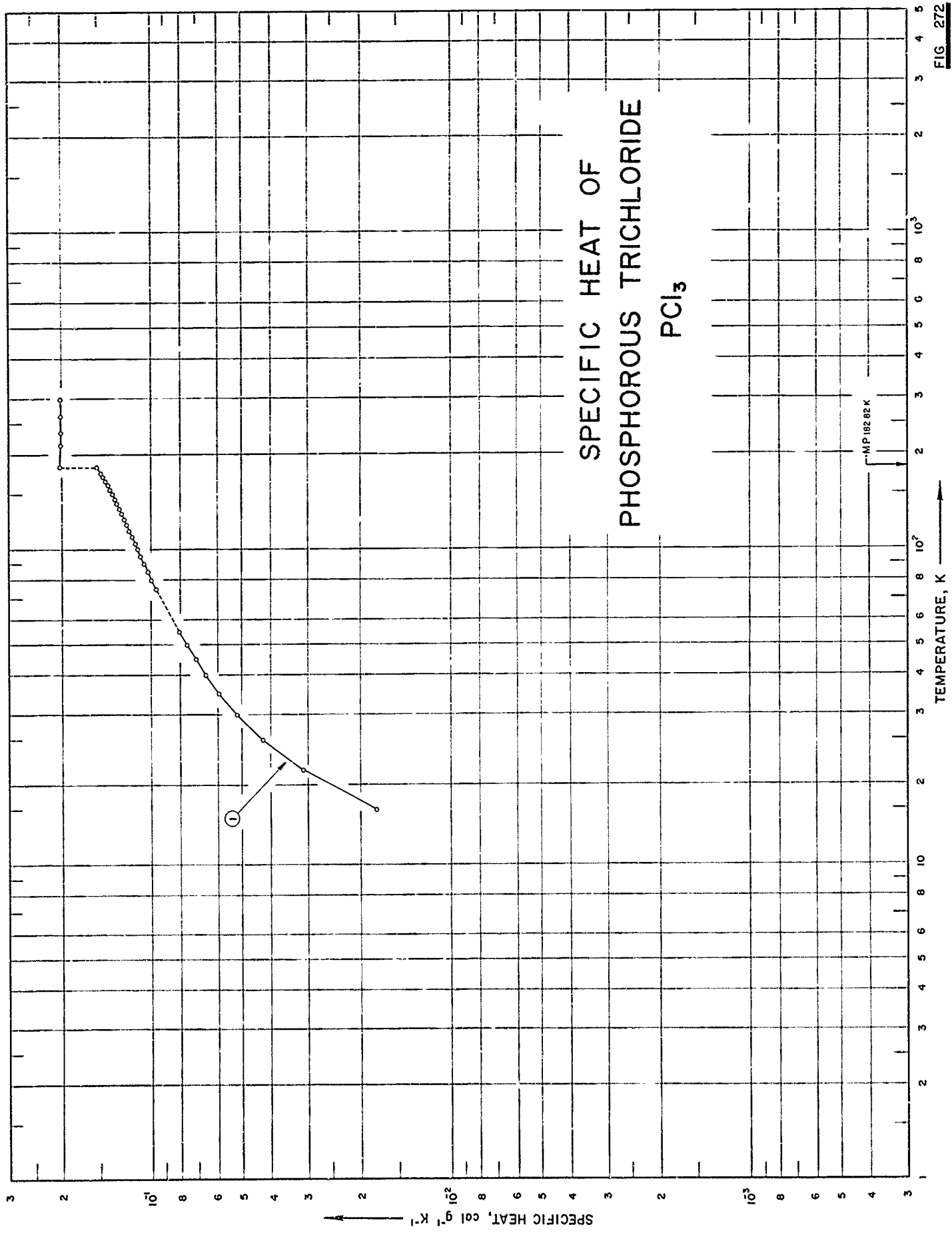

SPECIFICATION TABLE NO. 272 SPECIFIC HEAT OF PHOSPHORUS TRICHLORIDE PCl_3

[For Data Reported in Figure and Table No. 272]

Curve No.	Ref. No.	Year	Temp. Range, K	Reported Error, %	Name and Specimen Designation	Composition (weight percent), Specifications and Remarks
1	265	1960	15-300			99.71 PCl_3 ; reagent grade.

DATA TABLE NO. 272 SPECIFIC HEAT OF PHOSPHOROUS TRICHLORIDE PCl_3 [Temperature, T, K; Specific Heat, Cp, Cal $\text{g}^{-1}\text{K}^{-1}$]

T	Cp	T	Cp
CURVE 1		CURVE 1 (cont.)	
Solid			
15		210	2.011×10^{-4} *
20	1.794×10^{-2}	215	2.009
25	3.118	220	2.008*
30	4.274	225	2.007*
35	5.201	230	2.006*
40	5.975	235	2.005
45	6.617	240	2.004*
50	7.167	245	2.004*
55	7.659	250	2.004*
	8.117	255	2.005*
		260	2.005*
		265	2.006
		270	2.007*
Transition			
75	9.698×10^{-2}	273.16	2.008*
80	1.003×10^{-1}	275	2.009*
85	1.035	280	2.010*
90	1.064	285	2.011*
95	1.090	290	2.013*
100	1.115	295	2.014*
105	1.141	298.16	2.015*
110	1.168	300	2.016
115	1.193		
120	1.217		
125	1.241		
130	1.265		
135	1.288		
140	1.311		
145	1.334		
150	1.357		
155	1.381		
160	1.406		
165	1.431		
170	1.456		
175	1.482		
180	1.508*		
182.82	1.524		
Liquid			
182.82	2.029×10^{-1}		
185	2.027*		
190	2.023*		
195	2.019*		
200	2.016*		
205	2.013*		

* Not shown on plot

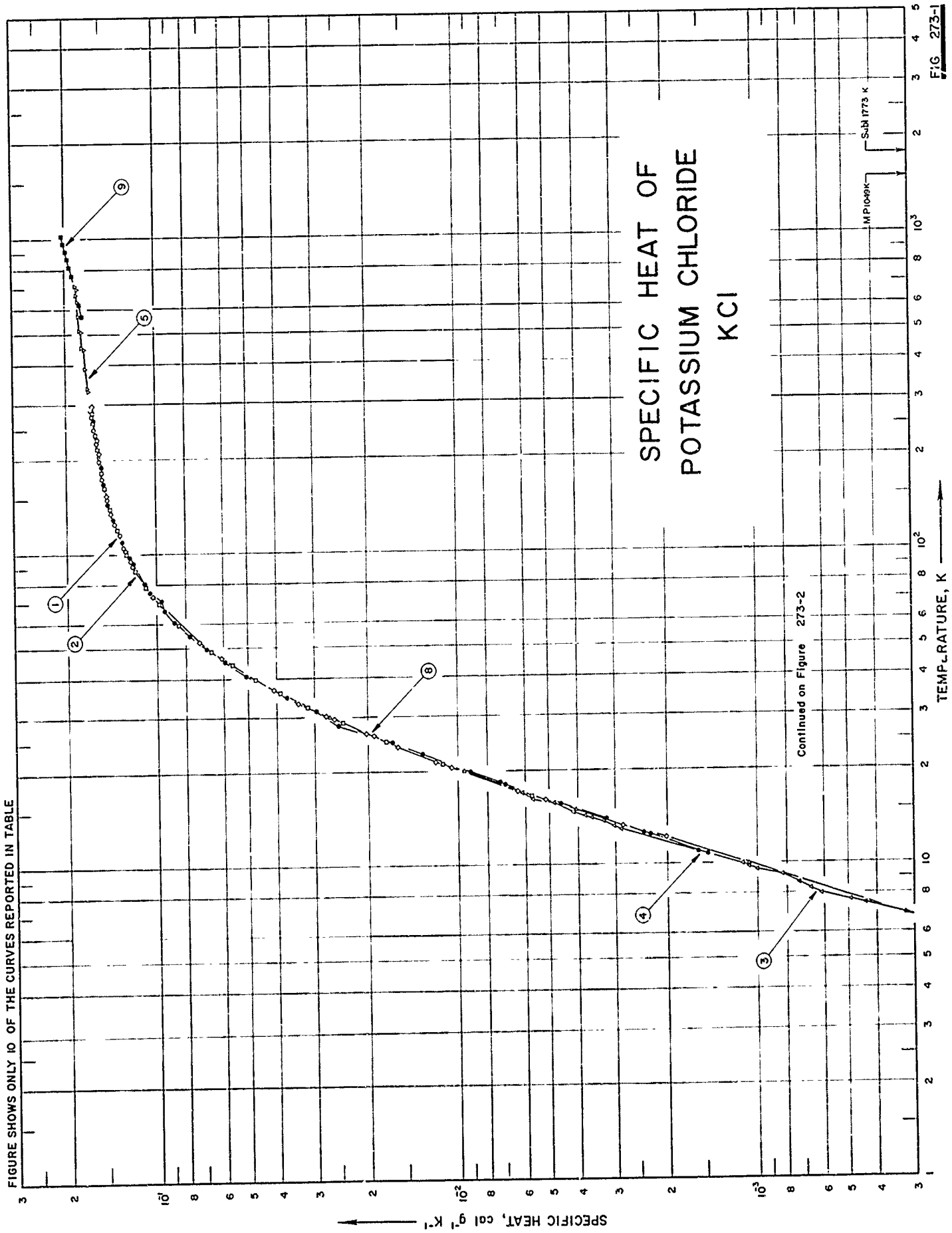

FIGURE SHOWS ONLY 10 OF THE CURVES REPORTED IN TABLE

FIG. 273-1

SPECIFIC HEAT OF POTASSIUM CHLORIDE KCl

CONTINUED FROM FIGURE 273-1

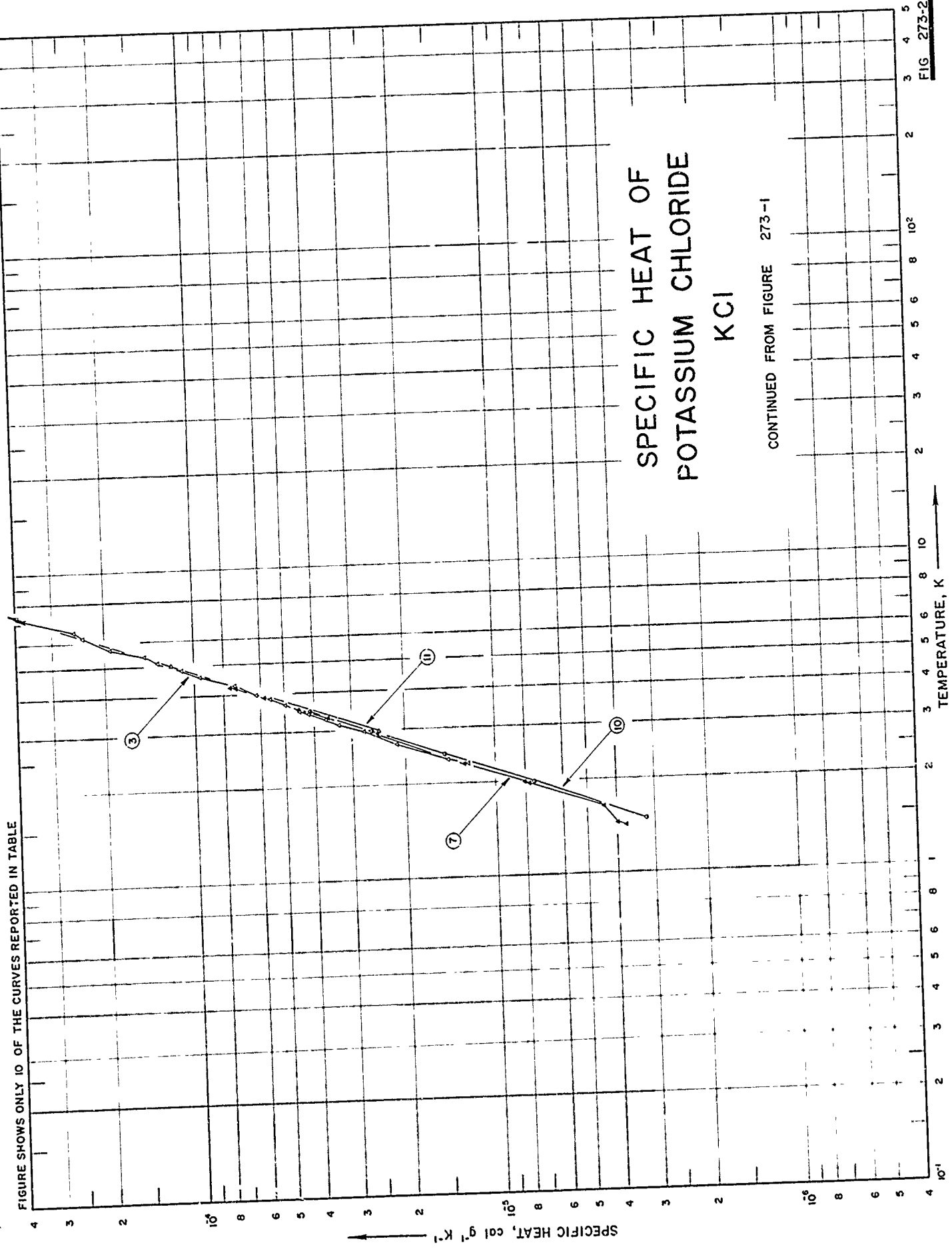

FIGURE SHOWS ONLY 10 OF THE CURVES REPORTED IN TABLE

SPECIFICATION TABLE NO. 273 SPECIFIC HEAT OF POTASSIUM CHLORIDE KCl

[For Data Reported in Figure and Table No. 273]

Curve No.	Ref. No.	Year	Temp. Range, K	Reported Error, %	Name and Specimen Designation	Composition (weight percent), Specifications and Remarks
1	266	1933	32-287			C. P. pure; recrystallized 3 or 4 times; dried under high vacuum 2 days; heated to 700 C. Same as above; dried under high vacuum 5 days; fused with subsequent grinding.
2	266	1933	17-285			
3	267	1935	2.3-17			
4	243	1949	11-268			
5	268	1951	335-718			
6	268	1951	335-721			
7	269	1953	1.5-4.3			
8	270	1954	12-298			Single crystal; 37 mm dia, 88 mm length (18.9 g); sample supplied by the Harshaw Chemical Co.
9	244	1955	573-1023			
10	271	1955	1.5-1.0			Single crystal; 3 cm dia, 8 cm length, (160 g). High purity, optical quality; sample supplied by the Harshaw Chemical Co; measured in a helium atmosphere.
11	245	1957	2.5-270	0.2-2		
12	272	1961	313-388	1.0		Measured in 10 ⁻⁵ mm Hg vacuum atmosphere.
13	272	1961	313-388	1.0		
14	273	1962	60-350	0.2		

DATA TABLE NO. 273 SPECIFIC HEAT OF POTASSIUM CHLORIDE KCl

[Temperature, T, K; Specific Heat, Cp, Cal g⁻¹°K⁻¹]

CURVE 1			CURVE 2 (cont.)			CURVE 2 (cont.)			CURVE 3 (cont.)			CURVE 4			CURVE 4 (cont.)		
T	Cp		T	Cp		T	Cp		T	Cp		T	Cp		T	Cp	
92.26	1.210 x 10 ⁻¹		39.86	4.739 x 10 ⁻²		217.26	1.573 x 10 ^{-1*}		Series II		10.8	6.71 x 10 ⁻⁴		191.6	7.66 x 10 ⁻²		
96.84	1.246*		44.25	5.619		217.97	1.576		2.35	1.26 x 10 ⁻⁵	11.1	4.02		198.4	7.70		
101.70	1.269*		49.27	6.607		219.04	1.577*		2.42	1.45	12.6	1.07 x 10 ⁻³		201.8	7.71		
106.86	1.298		54.44	7.606*		223.61	1.583*		2.44	1.90*	12.7	1.21		204.3	7.74		
111.94	1.321*		59.61	8.485		224.65	1.584*		2.62	2.61*	14.1	1.61		207.8	7.73		
116.96	1.345		64.94	9.246*		229.29	1.589*		2.71	2.16	14.2	1.61		213.4	7.86		
121.93	1.367*		69.92	9.879		230.28	1.591*		Series III		15.7	2.41		220.4	7.83		
126.86	1.390		74.62	1.041 x 10 ^{-1*}		235.01	1.591*		4.60	9.71 x 10 ⁻⁵	15.7	2.28		227.1	7.85		
136.58	1.424		79.11	1.054		235.93	1.597*		4.87	1.12 x 10 ⁻⁵	17.0	2.82		233.2	7.89		
141.44	1.439*		84.10	1.147*		240.70	1.599		5.14	1.35	18.2	3.49		239.6	7.93		
146.29	1.455*		89.28	1.186		241.62	1.603*		5.40	1.50	18.5	3.62		244.9	7.91		
151.13	1.466		90.80	1.194*		246.41	1.607*		5.72	1.95	19.9	4.56		251.6	7.97		
152.92	1.474*		94.32	1.224*		247.32	1.607*		6.14	2.12	22.7	6.57		259.2	8.01		
155.97	1.481*		96.10	1.235*		252.15	1.610		6.73	2.55*	28.2	8.32		267.6	8.07		
158.65	1.482*		101.31	1.266		252.68	1.612*		7.45	4.40	24.8	1.26 x 10 ⁻²					
164.31	1.501*		106.43	1.295*		257.80	1.614*		7.89	5.23*	31.5	1.49					
169.88	1.508*		111.48	1.320*		262.94	1.618*		8.00	6.17	31.5	1.55					
175.64	1.524		116.47	1.345*		263.70	1.611*		8.23	6.68	34.9	2.52					
181.29	1.529*		121.41	1.364		268.15	1.616*		8.46	6.76*	41.2	2.54					
187.01	1.540*		126.22	1.387*		269.52	1.630*		8.70	7.30	45.5	2.99					
192.72	1.547*		131.15	1.403*		273.34	1.630*		8.94	7.73*	50.1	3.43					
198.44	1.560*		136.04	1.423*		278.54	1.636*		9.23	8.32	55.3	3.92					
204.18	1.566*		141.15	1.443		284.68	1.643		Series IV		61.3	4.39					
209.95	1.568*		146.58	1.455*					9.53	1.01 x 10 ⁻³	66.5	4.39					
215.74	1.571*		152.30	1.469*					9.81	1.08	71.8	1.15					
221.59	1.577*		158.02	1.483*					10.06	1.12	76.8	1.20					
227.42	1.587		163.45	1.494					13.01	2.87	81.0	1.53 x 10 ⁻²					
233.30	1.589*		168.88	1.504*					13.22	3.03	90.4	5.97					
239.20	1.600*		172.60	1.511*					13.55	3.19*	98.0	6.02					
245.11	1.612*		174.31	1.513*					13.85	3.30	101.7	6.20					
251.05	1.618		177.99	1.520*					14.20	3.62	105.8	6.41					
257.02	1.623*		179.39	1.524*					14.47	3.81	110.7	6.56					
263.03	1.628*		179.76	1.524*					14.73	4.16	116.0	6.65					
269.06	1.632*		183.41	1.528					15.84	4.83	121.1	6.83					
275.12	1.646		184.85	1.530*					16.82	4.16	125.8	6.88					
281.20	1.651*		185.22	1.536					17.45	5.69	130.7	7.00					
287.30	1.655		188.83	1.538*					17.69	5.69	136.1	7.11					
			190.32	1.540*					18.83	5.87*	142.3	7.16					
			194.28	1.544*					19.32	6.14	148.9	7.28					
			195.81	1.547*					20.32	6.30	155.8	7.31					
16.69	5.73 x 10 ⁻³		199.74	1.551*					21.47	7.43	161.7	7.39					
21.21	1.13 x 10 ⁻²		201.32	1.555*					22.43	7.43	168.2	7.51					
25.06	1.746		205.23	1.561*					23.43	6.14	174.5	7.56					
28.81	2.428		206.85	1.568*					24.29	6.14	178.8	7.61					
32.41	3.165		210.73	1.568*					Series I		181.5	7.61					
36.90	3.913		212.40	1.572*					2.99	2.76 x 10 ⁻⁵							
									3.16	3.35							
									3.28	3.70							
									3.37	3.89*							
									3.43	4.21							
									3.52	4.53							
									3.62	4.80*							
									3.71	5.04							
									3.81	5.37*							
									3.86	5.69							
									3.92	5.93*							
									4.01	6.30							
									4.10	6.60*							
									4.29	7.43							

* Not shown on plot

DATA TABLE NO. 273 (continued)

T	Cp	T	Cp	T	Cp	T	Cp	T	Cp	T	Cp	
<u>CURVE 6 (cont.)</u>												
635.75	1.818 x 10 ⁻¹	20.68	1.06 x 10 ⁻²	103.36	1.273 x 10 ^{-1*}	276.76	1.6177 x 10 ^{-1*}	150	1.463 x 10 ^{-1*}	60	8.417 x 10 ⁻²	
681.65	1.824*	20.82	1.09*	104.21	1.290	284.06	1.6223*	175	1.516*	65	9.205	
692.05	1.835*	20.88	1.09*	104.63	1.280*	284.47	1.6259*	200	1.583*	70	9.856	
701.55	1.840	21.32	1.13*	110.84	1.309*	285.35	1.6290*	225	1.583*	75	1.042 x 10 ⁻¹	
714.65	1.850*	21.56	1.20	111.66	1.315*	292.06	1.6306*	250	1.606*	80	1.094	
721.35	1.840	21.75	1.24*	119.00	1.3630*	292.83	1.6338*	270	1.622*	85	1.141	
<u>CURVE 7</u>												
Series I												
4.231	7.386 x 10 ⁻⁵	26.15	1.918	121.23	1.3582*	<u>CURVE 9</u>						
4.230	7.386*	26.31	1.972*	139.56	1.4306*	573.15	1.758 x 10 ⁻¹	313	1.69 x 10 ⁻¹	105	1.279	
3.912	5.861*	26.48	1.977*	140.22	1.4270*	623.15	1.794	318	1.69	110	1.306	
3.929	5.944	28.68	2.424*	144.41	1.4355*	673.15	1.828*	323	1.69	115	1.331	
3.567	4.548*	28.77	2.445*	145.74	1.4408*	723.15	1.862*	328	1.70	120	1.353	
3.567	4.548*	29.64	2.587	154.48	1.4664*	773.15	1.894	333	1.70	125	1.373	
3.312	3.531*	30.00	2.579*	156.64	1.4686*	823.15	1.926	343	1.70	130	1.392	
3.316	3.660	30.27	2.735*	157.39	1.4705*	873.15	1.956	348	1.70	135	1.410	
2.924	2.472*	30.43	2.764	165.00	1.4930*	923.15	1.986	353	1.71	140	1.426	
2.925	2.472	33.43	3.426*	167.62	1.4867*	973.15	2.014	358	1.71	145	1.439	
<u>CURVE 10</u>												
Series II												
1.466	2.999 x 10 ⁻⁶	33.56	3.396*	168.67	1.4868*	1023.15	2.042	363	1.71	155	1.465	
1.434	2.742	36.13	3.956*	186.79	1.5242*	<u>CURVE 11</u>						
1.441	2.727*	36.19	4.002*	187.85	1.5269*	1.5	3.21 x 10 ⁻⁶	373	1.72	165	1.488	
1.667	4.426	36.89	4.104	197.40	1.5356*	2.0	7.50	378	1.72	170	1.497	
1.670	4.399*	39.46	4.709*	199.37	1.5483*	2.5	1.49 x 10 ⁻⁶	383	1.73	175	1.506	
1.985	7.829	39.56	4.764*	200.85	1.5448*	3.0	2.61	388	1.73	180	1.514	
2.012	8.072	45.76	5.974*	203.14	1.5515*	3.5	4.20	<u>CURVE 13*</u>				
2.324	1.286 x 10 ⁻⁵	46.73	6.134	204.67	1.5563*	4.0	6.32*	313	1.70	195	1.539	
2.325	1.258*	47.08	6.173*	212.92	1.5574	<u>CURVE 12*</u>						
4.247	7.739*	47.88	6.173*	214.09	1.5640*	<u>CURVE 11</u>						
4.293	7.707	52.00	5.737*	223.27	1.5708*	2.5	1.502 x 10 ⁻⁶ *	318	1.70	200	1.545	
<u>CURVE 8</u>												
12.21	2.01 x 10 ⁻³	52.71	7.247	224.57	1.5776*	3	2.468	318	1.70	205	1.552	
13.37	2.84	60.12	8.394*	227.68	1.5779*	5	1.212 x 10 ⁻⁴	323	1.65	210	1.559	
14.03	3.23*	60.61	8.473*	229.81	1.5833*	10	1.078 x 10 ⁻³	328	1.69	215	1.565	
15.90	4.79*	66.57	9.420*	234.50	1.5790*	15	4.051	333	1.70	220	1.577	
16.26	5.15	67.30	9.522*	245.90	1.5948*	20	9.563	343	1.71	225	1.583	
17.36	6.37	73.98	1.034 x 10 ⁻¹	248.22	1.5961*	25	1.740 x 10 ⁻² *	348	1.71	230	1.587	
<u>CURVE 8</u>												
12.21	2.01 x 10 ⁻³	74.54	1.041*	252.41	1.6027*	30	2.671	353	1.71	235	1.592	
13.37	2.84	80.71	1.113*	253.96	1.6015*	35	1.740 x 10 ⁻² *	358	1.72	240	1.596	
14.03	3.23*	80.99	1.108*	261.94	1.6163*	40	4.778*	363	1.72	245	1.600	
15.90	4.79*	89.09	1.185*	263.32	1.6090*	45	6.783*	368	1.72	250	1.606	
16.26	5.15	89.32	1.185*	274.91	1.6176*	50	8.490*	373	1.73	255	1.610	
17.36	6.37	94.50	1.216*	274.94	1.6202*	60	1.099 x 10 ⁻¹ *	378	1.74	265	1.615	
<u>CURVE 14*</u>												
12.21	2.01 x 10 ⁻³	96.92	1.225	275.15	1.6204*	80	1.258*	383	1.73	270	1.619	
13.37	2.84	98.33	1.239*	275.53	1.6212*	100	1.258*	388	1.74	275	1.623	
14.03	3.23*	99.53	1.247*	276.47	1.6230*	125	1.382*	388	1.74	280	1.627	
15.90	4.79*										285	1.631

* Not shown on plot

DATA TABLE NO. 273 (continued)

T	Cp
	<u>CURVE 14 (cont.) *</u>
290	1.635 x 10 ⁻¹
295	1.639
298.16	1.640
300	1.642
305	1.646
310	1.650
315	1.654
320	1.658
325	1.662
330	1.666
335	1.670
340	1.674
345	1.679
350	1.685

* Not shown on plot

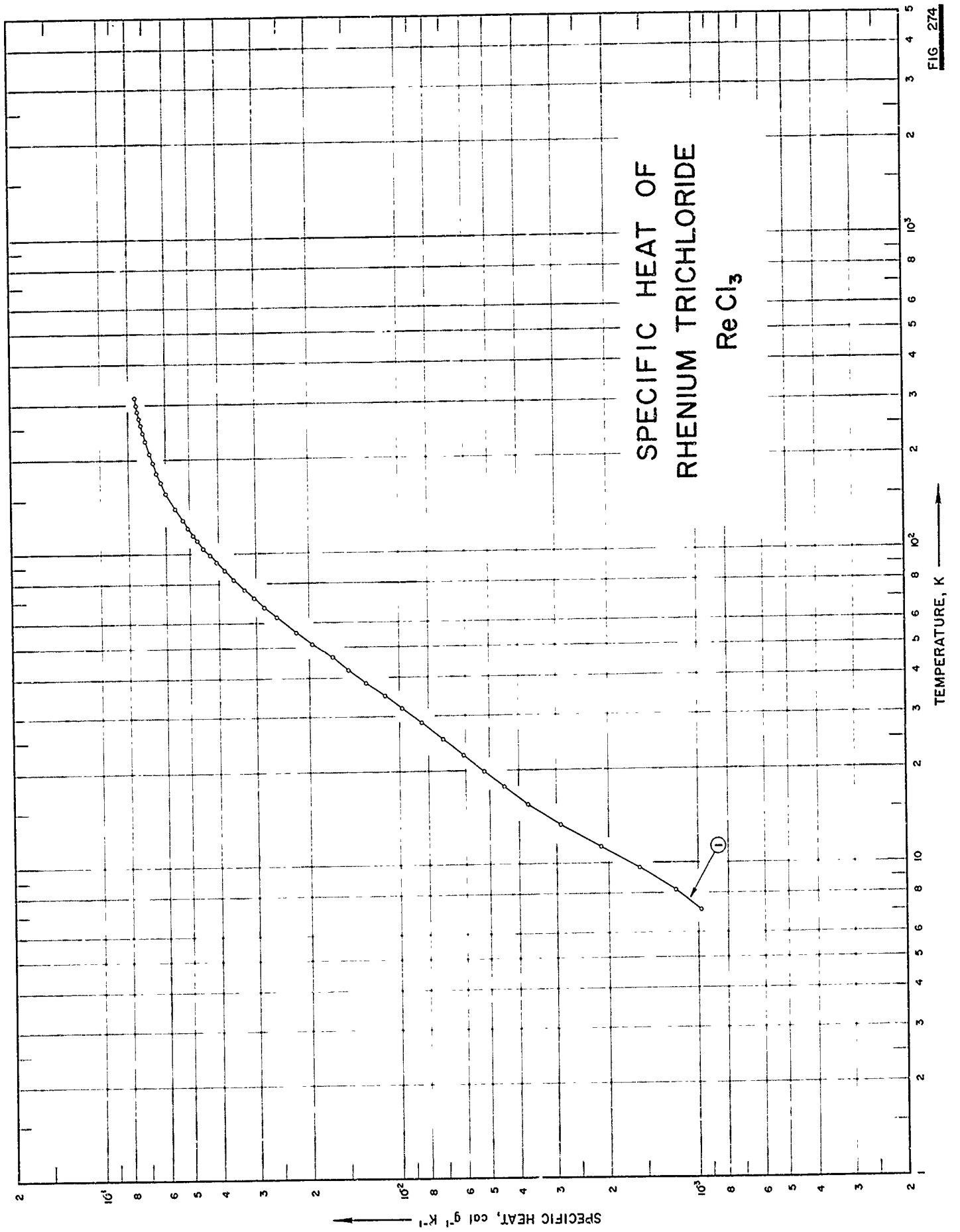

FIG. 274

SPECIFICATION TABLE NO. 274 SPECIFIC HEAT OF RHENIUM TRICHLORIDE ReCl_3

[For Data Reported in Figure and Table No. 274]

Curve No.	Ref. No.	Year	Temp. Range, K	Reported Error, %	Name and Specimen Designation	Compositor (weight percent), Specifications and Remarks
1	274	1966	7-312	0.1-5		$36.36 \pm 0.03 \text{ Cl}$ (36.355 theo.); density = 4.66 g cm^{-3} .

DATA TABLE NO. 274 SPECIFIC HEAT OF RHENIUM TRICHLORIDE ReCl_3 [Temperature, T, K; Specific Heat, Cp, Cal g⁻¹K⁻¹]

T	Cp	T	Cp
<u>CURVE 1</u>		<u>CURVE 1 (cont.)</u>	
Series I			
298.14	7.554×10^{-2} *	82.61	3.572×10^{-2}
305.47	7.585*	88.51	3.849
Series II			
115.61	4.888×10^{-2}	94.02	4.081
121.99	5.090	99.28	4.290
128.16	5.284	104.86	4.505
134.13	5.452*	110.75	4.720
139.94	5.602	Series IV	
145.62	5.749*	7.08	9.844×10^{-4}
156.78	6.002	8.17	1.196×10^{-3}
163.06	6.118*	9.66	1.583
169.22	6.241	11.38	2.133
175.29	6.351*	13.31	2.912
181.83	6.453	15.54	3.743
188.84	6.563*	17.69	4.495
195.74	6.649	19.86	5.240
202.57	6.744*	22.40	6.136
209.31	6.823	25.26	7.199
215.41	6.891*	28.55	8.453
222.66	6.973*	31.76	9.837
229.82	7.041	34.92	1.127×10^{-2}
236.92	7.103*	38.44	1.291
243.96	7.168	42.36	1.486
250.93	7.226*	46.74	1.674
257.85	7.277	51.42	1.964
264.72	7.325*	55.93	2.206
271.54	7.376	Series III	
278.30	7.424*	58.69	2.354×10^{-2} *
285.02	7.475	62.85	2.580
291.69	7.513*	67.49	2.820
298.33	7.547	72.16	3.053
304.94	7.575*	76.98	3.295
311.54	7.609	* Not shown on plot	

* Not shown on plot

FIG 275

SPECIFIC HEAT OF SILICON TETRACHLORIDE SiCl₄

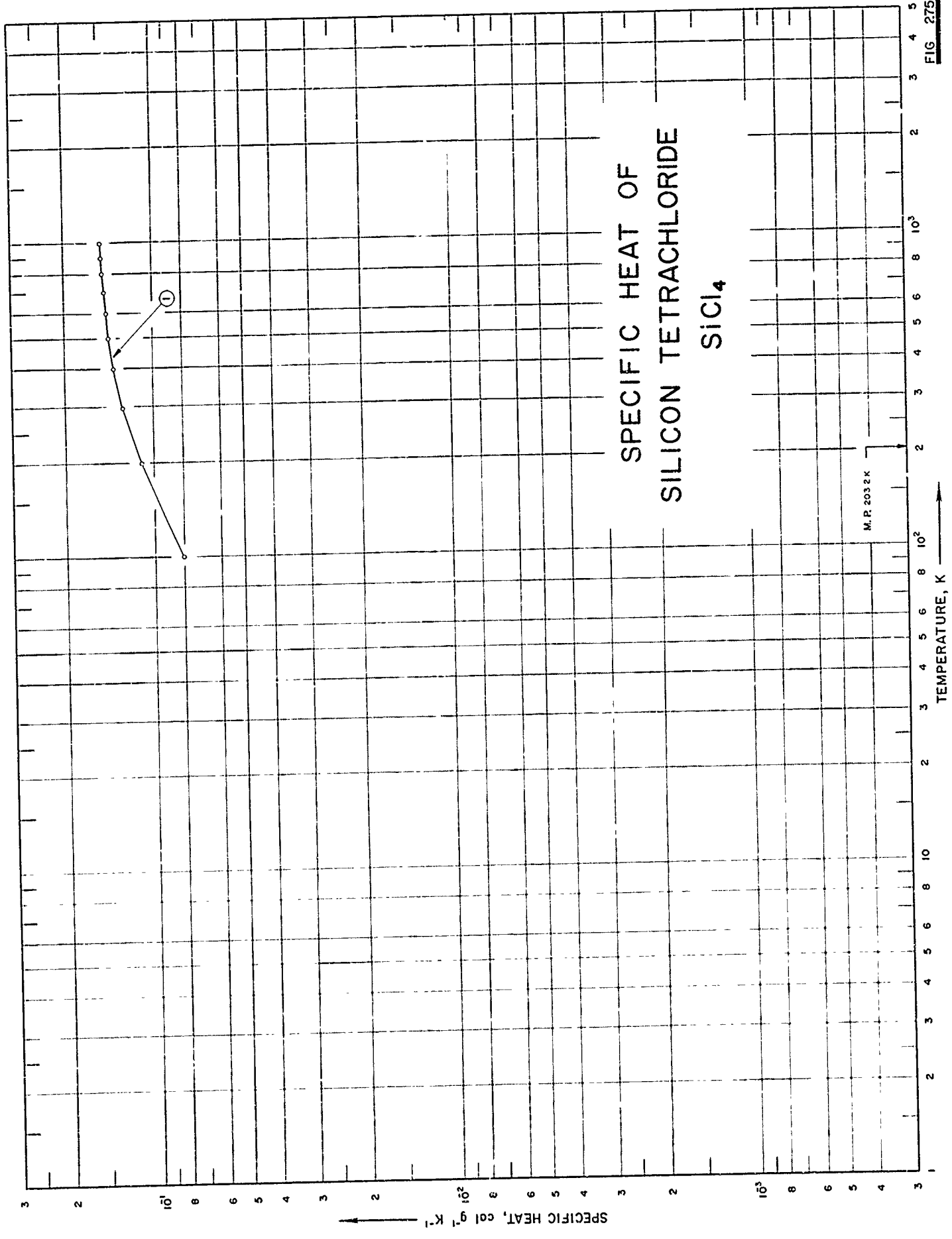

M.P. 203.2 K

TEMPERATURE, K

SPECIFIC HEAT, cal g⁻¹ K⁻¹

SPECIFICATION TABLE NO. 275 SPECIFIC HEAT OF SILICON TETRACHLORIDE SiCl_4

[For Data Reported in Figure and Table No. 275]

Curve No.	Ref. No.	Year	Temp. Range, K	Reported Error, %	Name and Specimen Designation	Composition (weight percent), Specifications, and Remarks
1	275	1953	100-1000			

DATA TABLE NO. 275 SPECIFIC HEAT OF SILICON TETRACHLORIDE SiCl_4 [Temperature, T, K; Specific Heat, Cp, Cal $\text{g}^{-1}\text{K}^{-1}$]

T	Cp
	<u>CURVE 1</u>
100	8.034×10^{-2}
200	1.109×10^{-1}
298.16	1.273*
300	1.275
400	1.364
500	1.414
600	1.444
700	1.463
800	1.476
900	1.485
1000	1.491

* Not shown on plot

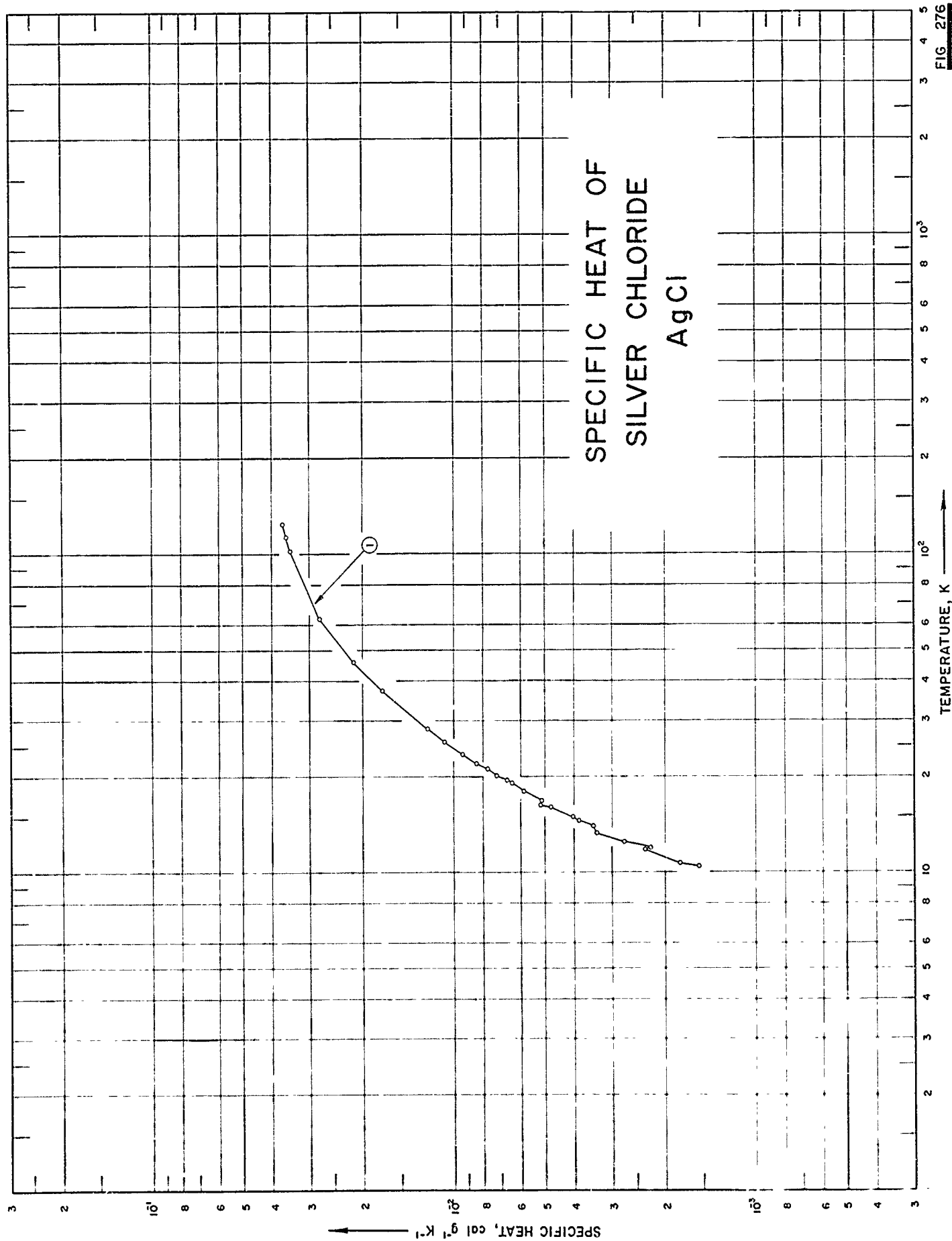

SPECIFICATION TABLE NO. 276 SPECIFIC HEAT OF SILVER CHLORIDE AgCl

[For Data Reported in Figure and Table No. 276]

Curve No.	Ref. No.	Year	Temp. Range, K	Reported Error, %	Name and Specimen Designation	Composition (weight percent), Specifications and Remarks
1	68	1928	11-126			

DATA TABLE NO. 276 SPECIFIC HEAT OF SILVER CHLORIDE AgCl

[Temperature, T, K; Specific Heat, Cp, Cal g⁻¹K⁻¹]

T	Cp
<u>CURVE 1</u>	
10.50	1.556 x 10 ⁻³
10.73	1.807
11.83	2.365
12.04	2.254
12.64	2.763
13.40	3.412
14.04	3.510
14.67	3.914
15.10	4.096
16.27	4.849
16.49	5.205
16.90	5.191
18.13	5.924
18.32	6.126*
19.22	6.482
19.65	6.719
20.25	7.284
21.30	7.780
22.20	8.491
23.60	9.419
24.00	9.670
25.90	1.085 x 10 ⁻²
28.5	1.235
37.5	1.741
46.3	2.153
63.3	2.785
103.1	3.493
114.0	3.592
125.6	3.698

* Not shown on plot

SPECIFIC HEAT OF SODIUM CHLORIDE NaCl

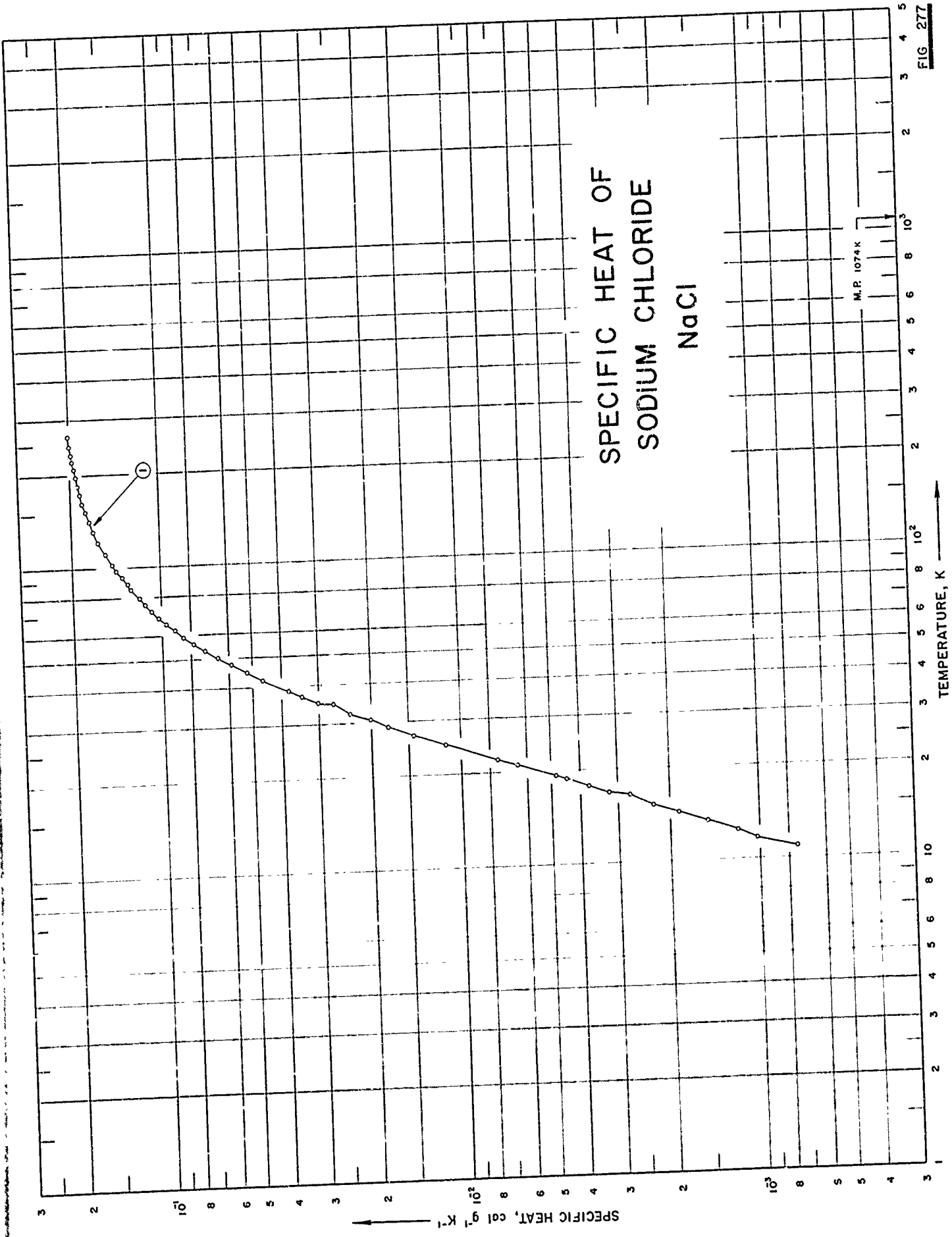

FIG. 277

SPECIFICATION TABLE NO. 277 SPECIFIC HEAT OF SODIUM CHLORIDE NaCl

[For Data Reported in Figure and Table No. 277]

Curve No.	Ref. No.	Year	Temp. Range, K	Reported Error, %	Name and Specimen Designation	Composition (weight percent), Specifications and Remarks
1	243	1949	11-268			

DATA TABLE NO. 277 SPECIFIC HEAT OF SODIUM CHLORIDE NaCl

[Temperature, T, K; Specific Heat, Cp, Cal g⁻¹K⁻¹]

T	Cp	T	Cp
10.9	7.53 x 10 ⁻⁴	132.6	1.687
11.7	1.03 x 10 ⁻³	137.7	1.714*
12.5	1.20	142.9	1.740
13.5	1.51	148.0	1.766*
14.4	1.88	153.2	1.786
15.3	2.29	158.6	1.806*
16.6	2.74	163.9	1.825
16.9	3.22	169.4	1.842*
17.8	3.76	174.9	1.859
18.9	4.45	180.6	1.874*
19.4	4.86	186.3	1.888
21.2	6.50	192.2	1.903*
22.2	7.56	198.1	1.916
25.1	1.13 x 10 ⁻²	198.1	1.916*
27.2	1.46	204.2	1.929*
29.0	1.76	210.3	1.940
30.7	2.02	216.4	1.949*
32.2	2.36	222.5	1.966
34.9	2.70	228.5	1.966*
35.4	3.04	235.7	1.975
37.2	3.450	241.2	1.980*
38.4	3.809	247.4	1.990
42.4	4.658	253.9	1.998*
45.1	5.256	260.6	2.006*
48.0	5.920	267.5	2.007
50.7	6.557		
53.6	7.214		
56.6	7.871		
59.4	8.518		
62.6	9.086		
65.8	9.705		
69.2	1.028 x 10 ⁻¹		
72.7	1.088		
76.4	1.143		
80.2	1.198		
85.7	1.271		
89.4	1.308		
93.9	1.363		
98.5	1.4161		
103.1	1.463		
107.7	1.537*		
112.3	1.547		
117.2	1.585*		
122.4	1.639		
127.7	1.657*		

* Not shown on plot

SPECIFICATION TABLE NO. 278 SPECIFIC HEAT OF STRONTIUM DICHLORIDE SrCl_2

[For Data Reported in Figure and Table No. 278]

Curve No.	Ref. No.	Year	Temp. Range, K	Reported Error, %	Name and Specimen Designation	Composition (weight percent), Specifications and Remarks
1	276	1963	7-300			> 99.99 SrCl_2 , impurities: 0.005-0.0005 Na, 0.002-0.0002 Ca, Al, and Ba, and traces of Cu, Mg, and Mn; recrystallized and dried at 600 C for 3 hrs.

DATA TABLE NO. 278 SPECIFIC HEAT OF STRONTIUM DICHLORIDE SrCl₂[Temperature, T, K; Specific Heat, Cp, Cal g⁻¹K⁻¹]

T	Cp	T	Cp	T	Cp
7.38	2.530 x 10 ⁻⁴	105.93	8.469 x 10 ⁻² *	224.12	1.089 x 10 ⁻¹
10.02	6.750	107.44	8.532	226.40	1.091*
11.22	7.444	109.92	8.644*	229.33	1.093*
12.49	1.413 x 10 ⁻³	110.79	8.682*	231.72	1.095*
13.87	2.031	114.08	8.813*	235.22	1.097
15.26	2.750	117.87	8.959	238.10	1.100*
16.47	3.406	121.58	9.095*	242.01	1.103*
17.80	4.277	125.24	9.214*	245.46	1.106
19.85	5.829	128.83	9.335	247.78	1.107*
22.16	7.746	131.27	9.412*	250.67	1.109*
23.92	9.229	132.74	9.455*	254.13	1.112*
25.39	1.071 x 10 ⁻²	135.30	9.530*	254.96	1.112
26.79	1.211	138.53	9.615	257.29	1.114*
28.13	1.359	142.28	9.709*	259.62	1.115*
29.57	1.520	144.83	9.772*	262.18	1.117*
31.20	1.719	146.57	9.808*	264.50	1.118*
33.42	1.989	148.84	9.861	268.24	1.120
35.99	2.300	151.54	9.919*	271.99	1.123*
38.22	2.576	152.87	9.951*	276.51	1.126*
40.22	2.820	155.48	9.999*	277.14	1.127*
42.20	3.063	158.53	1.006 x 10 ⁻¹	280.67	1.130
44.95	3.398	160.96	1.010*	286.05	1.140*
48.18	3.799	163.09	1.015*	289.54	1.142*
51.34	4.179	165.52	1.018*	292.36	1.144
54.48	4.541	168.40	1.023	294.20	1.145*
56.10	4.702*	170.03	1.026*	298.46	1.147*
57.35	4.858*	174.44	1.033*	300.43	1.149
58.65	4.996	174.49	1.033*		
60.63	5.205*	177.28	1.037*		
64.27	5.589	179.97	1.041		
64.69	5.625*	182.90	1.045*		
67.87	5.925*	186.66	1.051*		
70.85	6.196	191.50	1.057		
71.58	6.257*	194.19	1.059*		
75.21	6.558*	196.52	1.062*		
78.65	6.838	198.46	1.065*		
81.94	7.093*	201.47	1.068		
85.10	7.328	203.86	1.070*		
88.16	7.533*	206.64	1.073*		
91.31	7.717*	208.54	1.074*		
94.04	7.873	210.74	1.077*		
97.22	8.043*	213.26	1.079		
99.94	8.171	215.47	1.082*		
101.85	8.279*	217.22	1.083*		
103.74	8.366*	219.84	1.086*		

* Not shown on plot

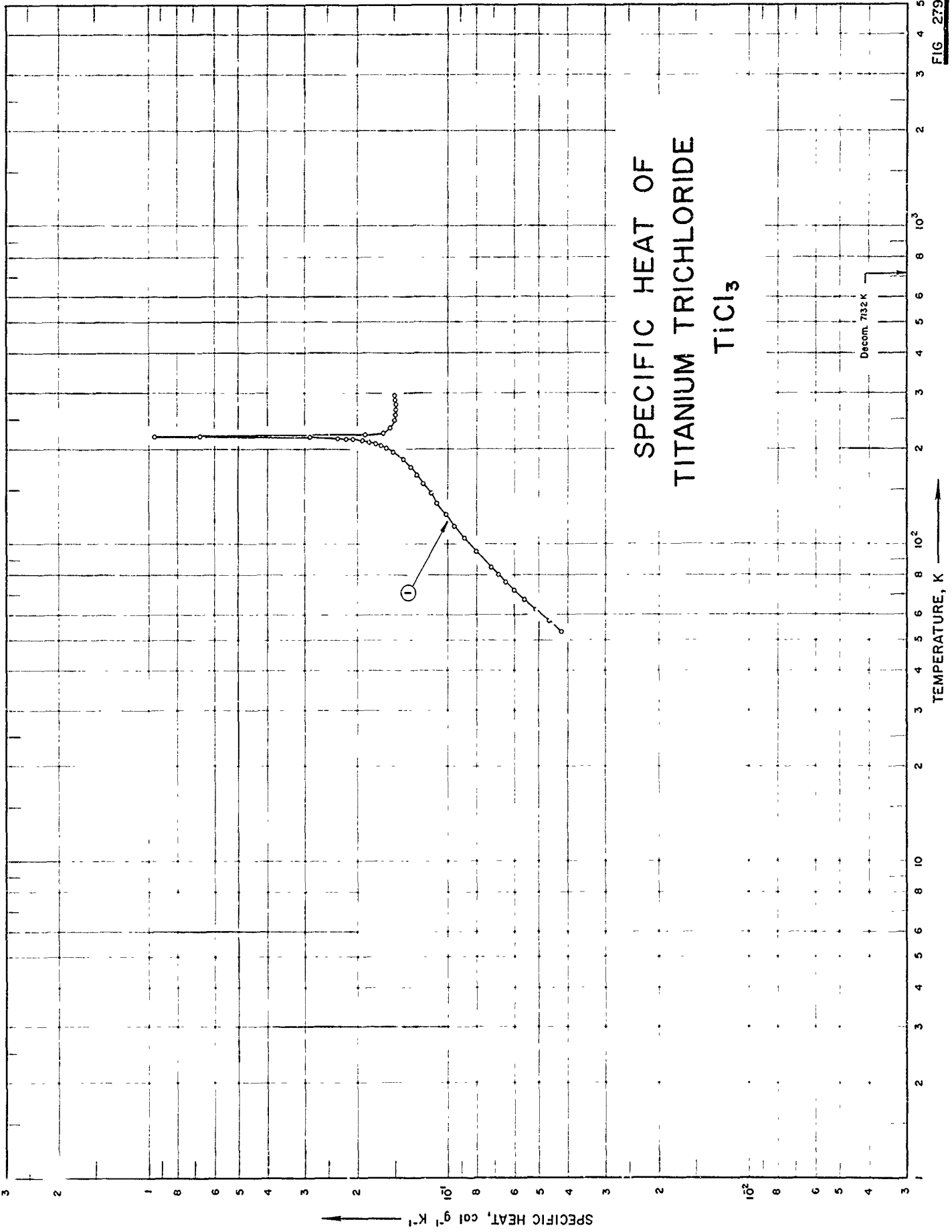

SPECIFICATION TABLE NO. 279 SPECIFIC HEAT OF TITANIUM TRICHLORIDE $TiCl_3$

[For Data Reported in Figure and Table No. 279]

Curve No.	Ref. No.	Year	Temp. Range, K	Reported Error, %	Name and Specimen Designation	Composition (weight percent), Specifications and Remarks
1	247	1961	53-296			68.98 Cl (68.95 theo.), 31.10 Ti (31.05 theo.), and <0.05 O ₂ .

DATA TABLE NO. 279 SPECIFIC HEAT OF TITANIUM TRICHLORIDE $TiCl_3$ [Temperature, T, K; Specific Heat, Cp, Cal $g^{-1}K^{-1}$]

T	Cp
	<u>CURVE 1</u>
53.27	4.219×10^{-2}
57.71	4.641
62.30	5.120
67.00	5.600
71.72	6.044
76.26	6.452
80.56	6.839
84.91	7.221
89.91	8.014
105.26	8.816
114.74	9.516
124.73	1.020×10^{-1}
136.24	1.091
145.98	1.147
156.00	1.210
165.90	1.272
175.94	1.339
186.12	1.420
196.15	1.525
202.17	1.613
205.61	1.678
206.23	1.693*
208.52	1.755
210.95	1.844
212.96	1.935
214.86	2.072
215.74	2.199
216.65	2.323
218.23	2.893
219.26	9.515
219.95	6.709
221.76	1.886
225.13	1.650
226.14	1.632*
229.16	1.596*
233.26	1.563
236.45	1.546*
237.69	1.540*
246.09	1.517
256.30	1.503
266.09	1.498
276.09	1.498
286.46	1.502
296.09	1.503

* Not shown on plot

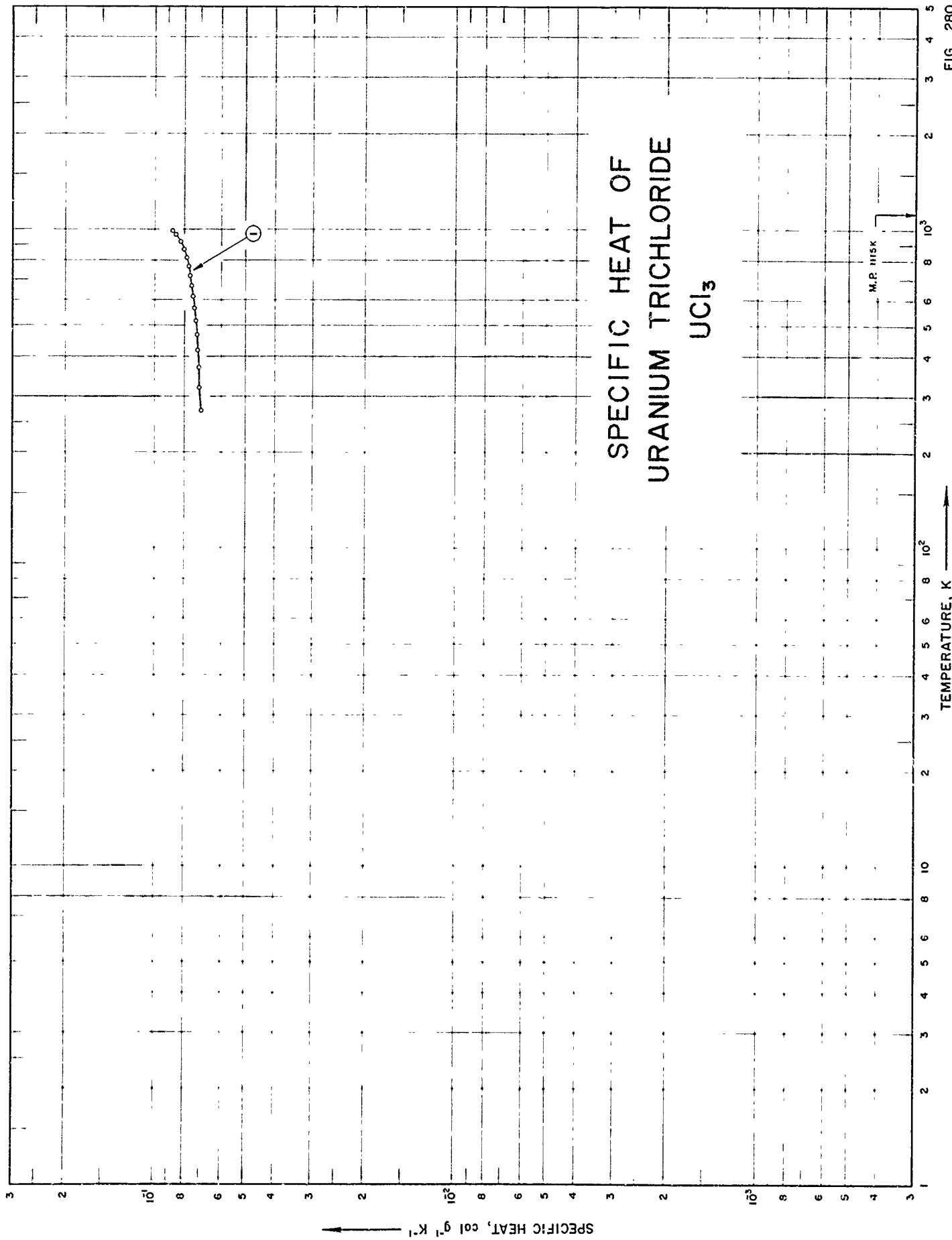

FIG. 280

SPECIFICATION TABLE NO. 280 SPECIFIC HEAT OF URANIUM TRICHLORIDE UCl_3

[For Data Reported in Figure and Table No. 280]

Curve No.	Ref. No.	Year	Temp. Range, K	Reported Error, %	Name and Specimen Designation	Composition (weight percent), Specifications and Remarks
1	277	1947	273-998			99.97 UCl_3 , 0.13 insoluble, 0.08 misc. metals, 0.02 Na, 0.013 Fe, 0.01 Mg, and 0.006 Si; sample supplied by E. C. Evers of Brown University; prepared from sublimed UCl_4 by reduction with H_2 .

DATA TABLE NO. 280 SPECIFIC HEAT OF URANIUM TRICHLORIDE UCl_3
 [Temperature, T, K; Specific Heat, Cp, Cal $g^{-1}K^{-1}$]

T	Cp
<u>CURVE 1</u>	
273.15	7.06 x 10 ⁻²
323.15	7.112
373.15	7.167
423.15	7.224
473.15	7.284
523.15	7.348
573.15	7.416
623.15	7.489
673.15	7.568
723.15	7.655
773.15	7.755
823.15	7.877
875.15	8.036
923.15	8.256
973.15	8.573
998.15	8.774

* Not shown on plot

SPECIFIC HEAT OF
URANIUM TETRACHLORIDE
 UCl_4

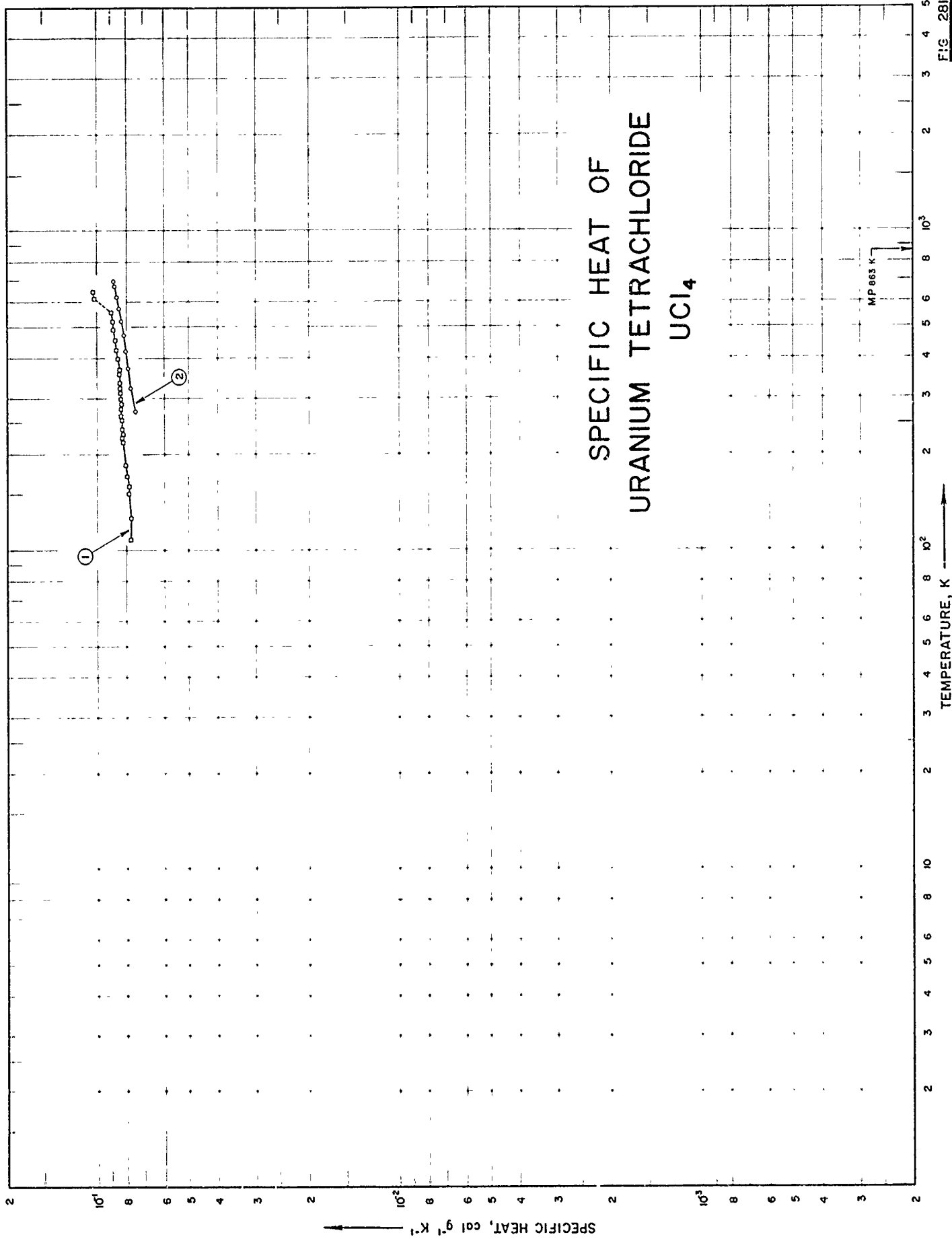

SPECIFICATION TABLE NO. 281 SPECIFIC HEAT OF URANIUM TETRACHLORIDE UCl_4

[For Data Reported in Figure and Table No. 281]

Curve No.	Ref. No.	Year	Temp. Range, K	Reported Error, %	Name and Specimen Designation	Composition (weight percent), Specifications and Remarks
1	277	1947	273-698			99.97 UCl_4 , 1.0-0.1 Ni, 0.1 misc metals (mainly Fe, 0.05), 0.02 Na, 0.01 each Ca, Mg, and 0.005 Al; prepared by reduction with H_2 .
2	325	1959	108-647	± 0.5		Impurities: 0.1 mainly Fe and Si.

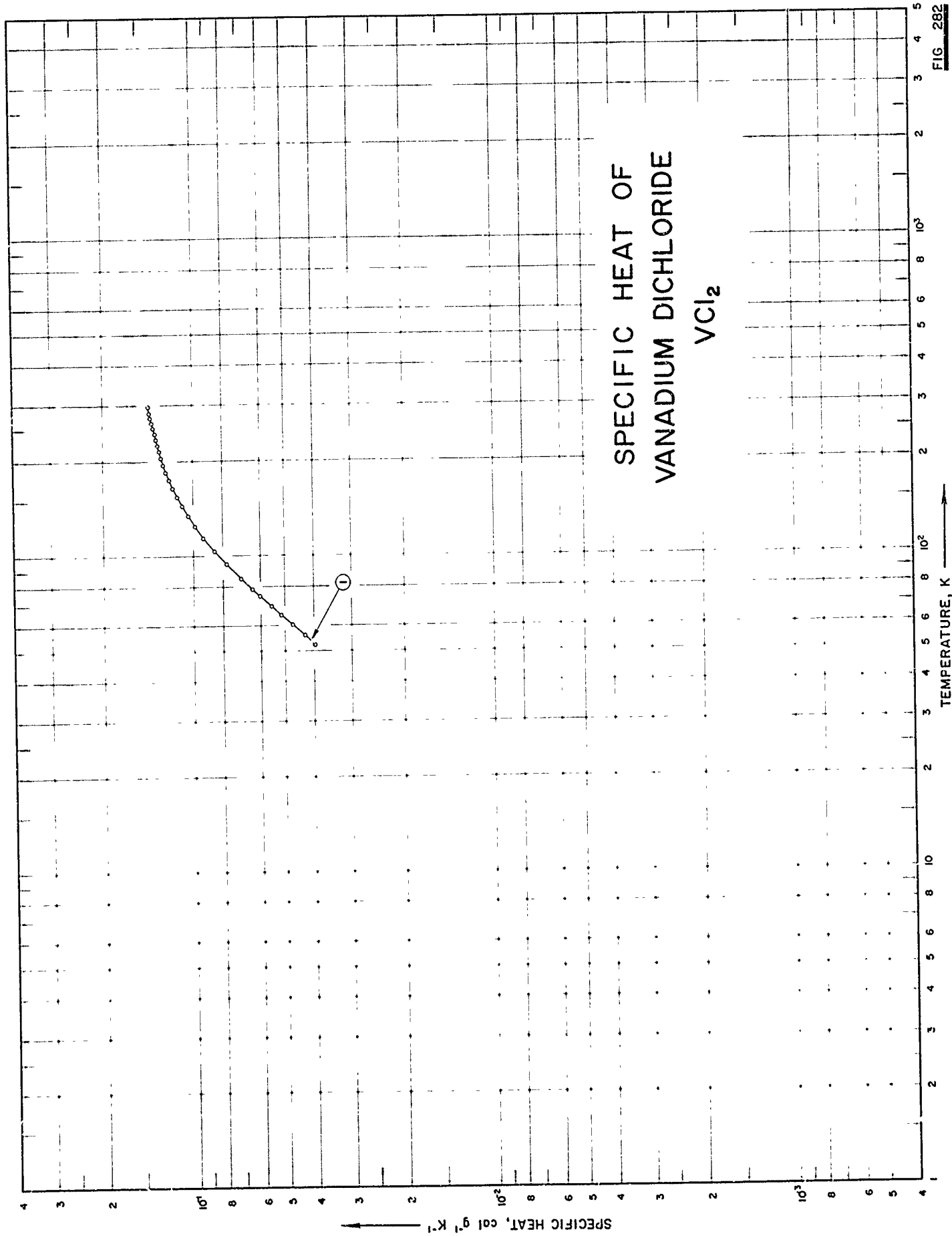

FIG 282

SPECIFICATION TABLE NO. 282 SPECIFIC HEAT OF VANADIUM DICHLORIDE VCl_2

[For Data Reported in Figure and Table No. 282]

Curve No.	Ref. No.	Year	Temp. Range, K	Reported Error, %	Name and Specimen Designation	Composition (weight percent), Specifications and Remarks
1	326	1947	53-298			99.8 VCl_2 ; 57.95 Cl_2 (58.19 theo.), 42.09 V (41.81 theo.), and 0.2 H_2O .

DATA TABLE NO. 232 SPECIFIC HEAT OF VANADIUM DICHLORIDE VCl_2
 [Temperature, T, K; Specific Heat, Cp, Cal g⁻¹K⁻¹]

T	Cp
52.5	3.995×10^{-2}
56.3	4.313
60.8	4.742
65.3	5.161
69.7	5.575
74.6	6.055
78.8	6.454
85.0	7.001
94.8	7.831
104.4	8.583
115.0	9.322
125.1	9.946
135.1	1.050×10^{-1}
145.7	1.099
155.5	1.141
165.5	1.177
175.5	1.213
185.6	1.242
196.0	1.262
205.9	1.285
216.2	1.305
226.2	1.322
235.8	1.336
246.3	1.350
256.1	1.370
266.3	1.379
276.2	1.392
286.4	1.404
296.5	1.414*
298.2	1.416

CURVE 1

*Not shown on plot

SPECIFIC HEAT OF VANADIUM TRICHLORIDE VCl_3

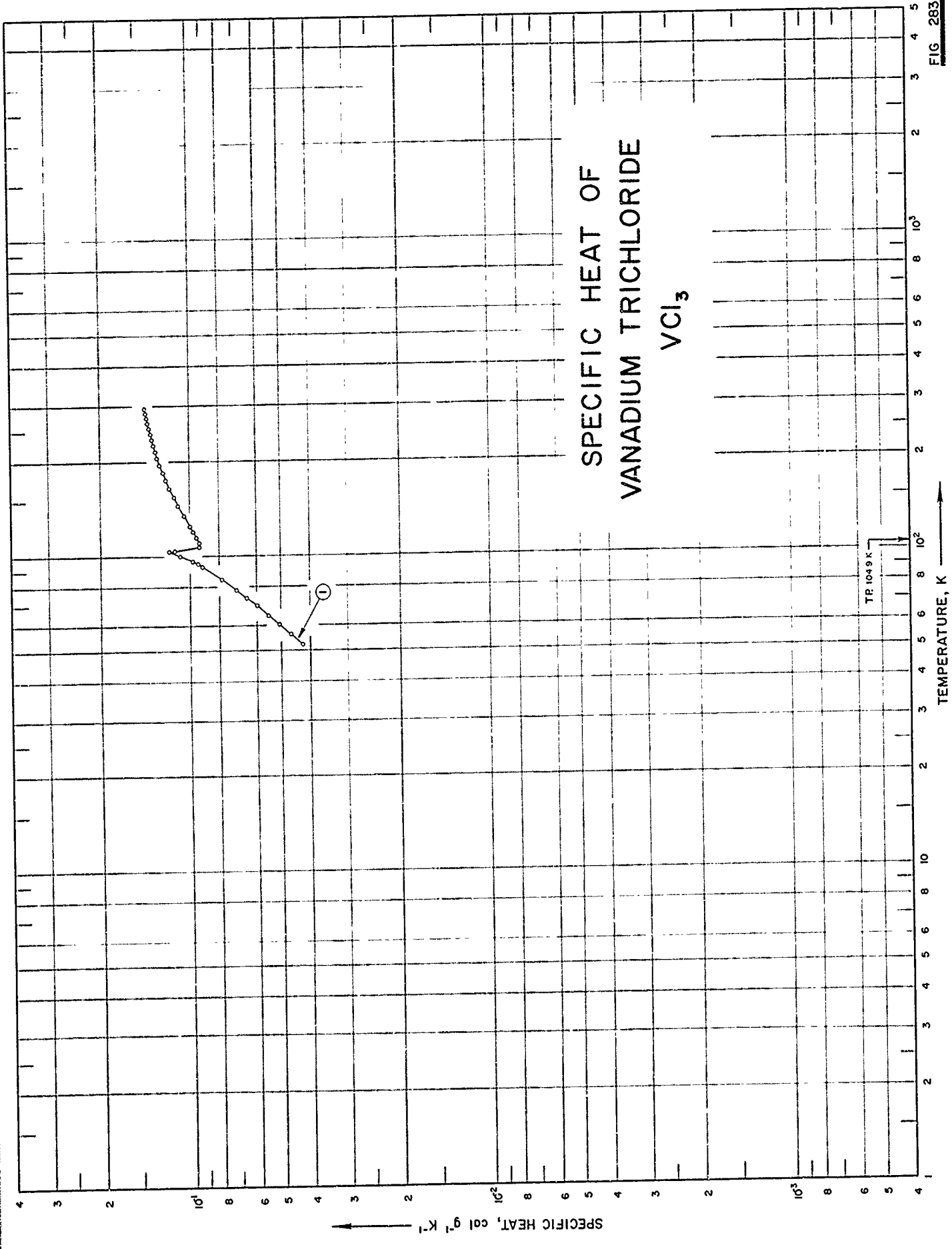

SPECIFICATION TABLE NO. 283 SPECIFIC HEAT OF VANADIUM TRICHLORIDE VCl_3

[For Data Reported in Figure and Table No. 283]

Curve No.	Ref. No.	Year	Temp. Range, K	Reported Error, %	Name and Specimen Designation	Composition (weight percent), Specifications and Remarks
1	326	1947	53-298			99.6 VCl_3 ; 67.45 Cl (67.61 theo.), 32.41 V (32.39 theo.), and 0.4 H_2O ; prepared from freshly distilled VCl_4 which had been obtained by passing chlorine gas over ferrovanadium at 250 C; heated at 160 C in stream of dry CO_2 for 24 hrs.

DATA TABLE NO. 283 SPECIFIC HEAT OF VANADIUM TRICHLORIDE VCl_3
 [Temperature, T, K; Specific Heat, Cp, Cal $\text{g}^{-1}\text{K}^{-1}$]

T	Cp
	<u>CURVE 1</u>
52.5	4.265×10^{-2}
56.6	4.658
60.6	5.078
64.9	5.521
69.2	6.002
73.6	6.515
78.0	7.049
84.6	7.888
92.8	9.102
94.7	9.433
96.8	9.833
100.6	1.086×10^{-1}
104.1	1.178
104.4	1.134
107.5	9.338
110.9	9.312
115.6	9.541
120.6	9.795
125.2	1.063
135.0	1.053
145.7	1.100
155.4	1.139
165.4	1.176
175.7	1.210
185.6	1.237
195.9	1.261
206.0	1.285
216.3	1.307
226.3	1.323
236.0	1.341
246.6	1.352
256.5	1.369
266.5	1.378
276.2	1.391
286.3	1.402
296.5	1.417*
298.15	1.416

* Not shown on plot

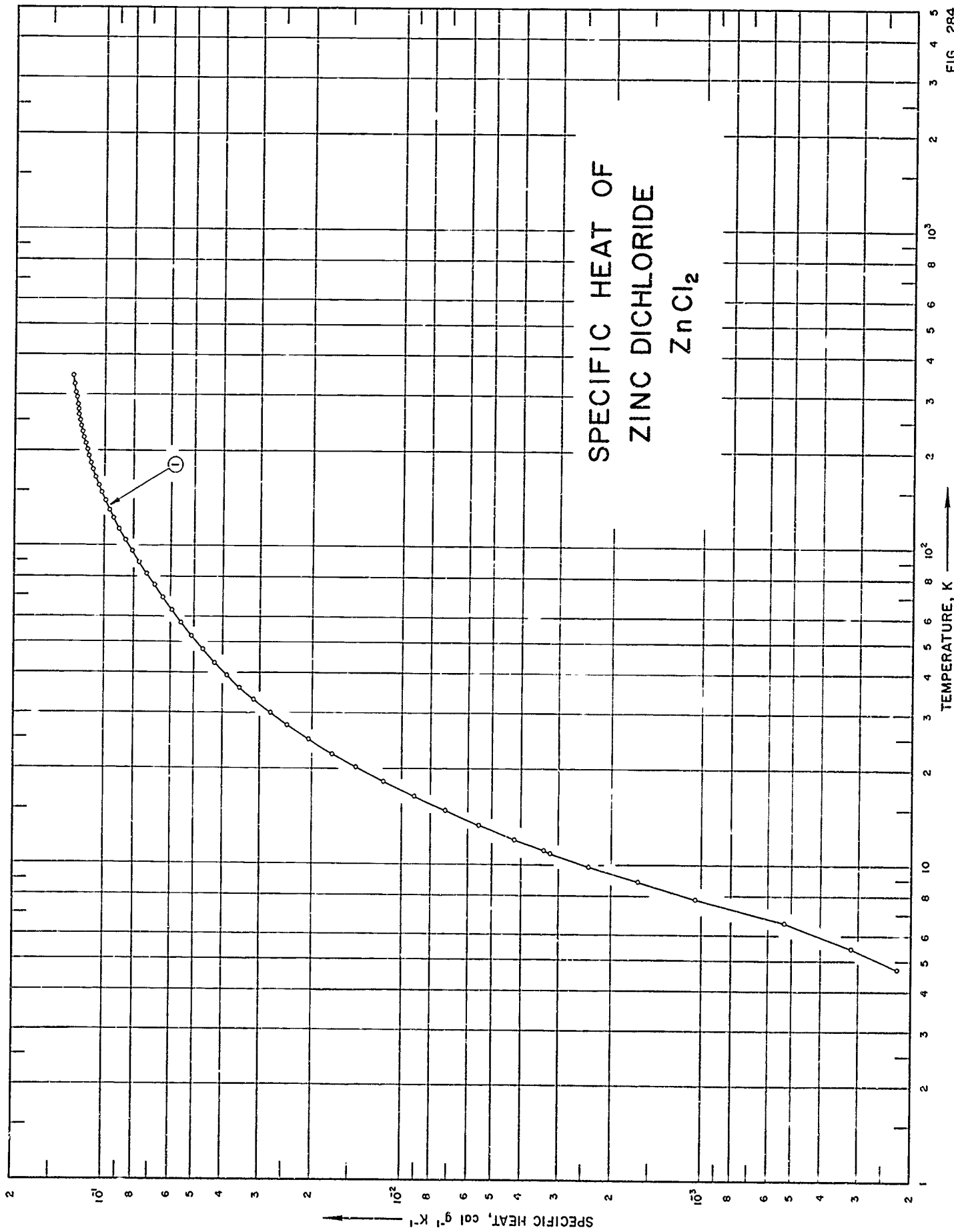

SPECIFICATION TABLE NO. 284 SPECIFIC HEAT OF ZINC DICHLORIDE ZnCl₂

[For Data Reported in Figure and Table No. 284]

Curve No.	Ref. No.	Year	Temp. Range, K	Reported Error, %	Name and Specimen Designation	Composition (weight percent), Specifications and Remarks
1	327	1956	5-346	0.15-6.0		51.90 Cl ₂ (52.03 theo.), and 47.97 Zn (47.97 theo.); prepared by passing HCl gas dried with CaSO ₄ over molten zinc (99.998 Zn) at 700 C.

DATA TABLE NO. 284 SPECIFIC HEAT OF ZINC DICHLORIDE $ZnCl_2$ [Temperature, T, K; Specific Heat, Cp, Cal $g^{-1}K^{-1}$]

T	Cp	T	Cp
<u>CURVE I</u>		<u>CURVE I (cont.)</u>	
Series I			
11.12	3.360×10^{-3}	139.21	9.949×10^{-2}
12.15	4.248*	147.89	1.024×10^{-1}
13.39	5.547*	156.83	1.050
14.88	7.212*	166.16	1.075
16.54	9.245*	175.55	1.097
18.36	1.160×10^{-2}	184.75	1.116
20.33	1.427	193.81	1.133
22.46	1.724	202.95	1.148
24.87	2.065	212.27	1.163
27.52	2.429	221.69	1.176
30.32	2.804*	231.26	1.189
		241.07	1.201
		251.01	1.211
		261.00	1.222
		271.05	1.228
		281.11	1.239
Series II			
4.73	2.201×10^{-4}	Series III	
5.48	3.155	276.54	1.232×10^{-1} *
6.61	5.283	286.30	1.242*
7.81	1.049×10^{-3}	296.44	1.250
8.86	1.636	306.78	1.258
9.88	2.377	317.04	1.264*
10.91	3.192	327.21	1.271
12.07	4.211	337.34	1.277*
13.38	5.525	346.44	1.283
14.83	7.176		
16.45	9.135		
30.08	2.765		
33.05	3.153		
36.09	3.518		
39.39	3.884		
43.13	4.261		
47.52	4.672		
52.42	5.093		
57.68	5.525		
63.24	5.942		
69.20	6.361		
75.61	6.791		
82.33	7.240		
89.00	7.654		
96.84	8.085		
105.17	8.518		
113.99	8.944		
123.00	9.333		
130.75	9.641		

* Not shown on plot

FIG 285

SPECIFIC HEAT OF ZIRCONIUM TETRACHLORIDE ZrCl4

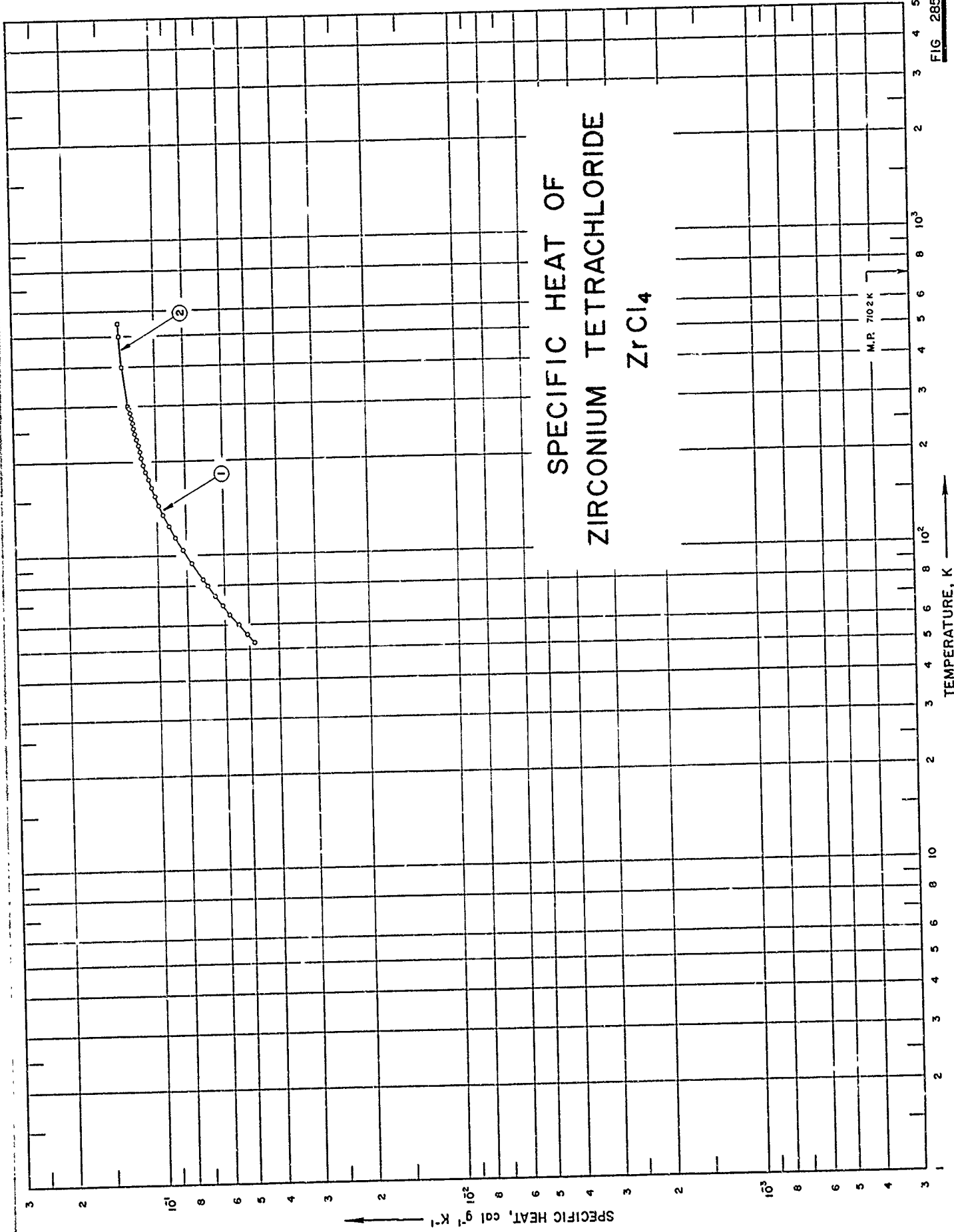

TEMPERATURE, K

SPECIFIC HEAT, cal g⁻¹ K⁻¹

SPECIFICATION TABLE NO. 285 SPECIFIC HEAT OF ZIRCONIUM TETRACHLORIDE $ZrCl_4$

[For Data Reported in Figure and Table No. 285]

Curve No.	Ref. No.	Year	Temp. Range, K	Reported Error, %	Name and Specimen Designation	Composition (weight percent), Specifications and Remarks
1	217	1950	53-296			39.21 Zr, 0.75 Hf; corrected for impurities.
2	278	1950	298-550	0.3		39.21 Zr, 0.75 Hf.

DATA TABLE NO. 285 SPECIFIC HEAT OF ZIRCONIUM TETRACHLORIDE $ZrCl_4$ [Temperature, T, K; Specific Heat, Cp, Cal $g^{-1}K^{-1}$]

T	Cp
<u>CURVE 1</u>	
52.6	1.823×10^{-4}
53.9	5.089
60.0	5.419
64.9	5.806
69.3	6.136
74.0	6.462
80.0	6.857
83.9	7.093
94.8	7.707
104.6	8.217
114.6	8.685
124.7	9.101
136.1	9.539
146.3	9.856
156.2	1.015×10^{-1}
166.3	1.041
176.3	1.067
186.4	1.087
196.4	1.105
206.7	1.122
216.6	1.138
226.7	1.150
236.4	1.163
246.3	1.174
256.5	1.187
266.4	1.199
276.5	1.209
286.8	1.217
296.7	1.228
<u>CURVE 2</u>	
298.15	1.229×10^{-1} *
300	1.231
400	1.292
500	1.320
550	1.325

* Not shown on plot

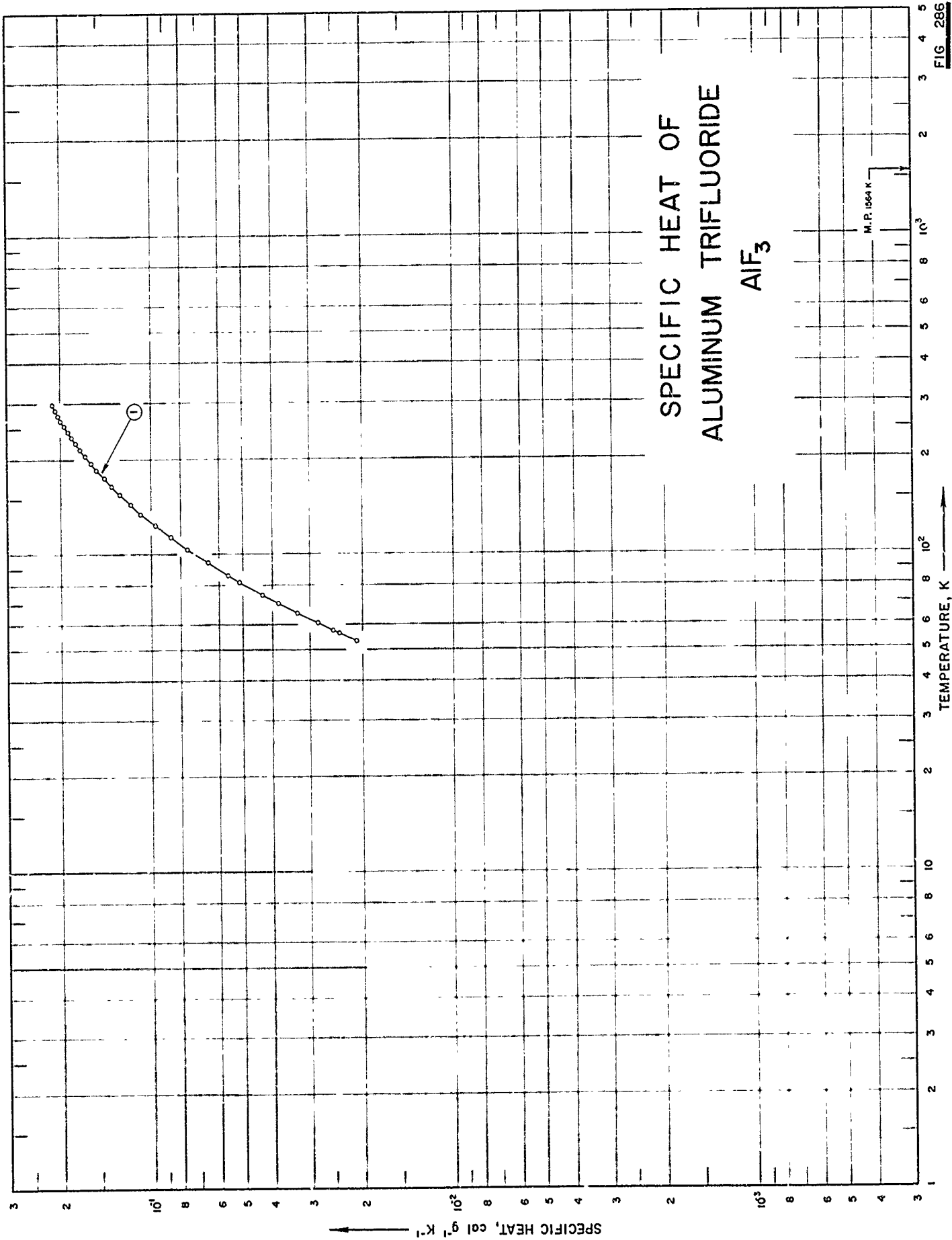

FIG. 286

PRECEDING PAGE BLANK-NOT FILMED

SPECIFICATION TABLE NO. 286 SPECIFIC HEAT OF ALUMINUM TRIFLUORIDE AlF_3

[For Data Reported in Figure and Table No. 286]

Curve No.	Ref. No.	Year	Temp. Range, K	Reported Error, %	Name and Specimen Designation	Composition (weight percent), Specifications and Remarks
1	279	1956	54-298			32.12 Al (32.13 theo.), 0.06 Ca, 0.008 Si, Fe, 0.005 Mg, Na, 0.003 Ti and others; sample supplied by the Reduction Research Laboratory, Kaiser Aluminum and Chem. Corp.

DATA TABLE NO. 286 SPECIFIC HEAT OF ALUMINUM TRIFLUORIDE AlF_3
 [Temperature, T, K; Specific Heat, Cp, Cal $\text{g}^{-1}\text{K}^{-1}$]

T	Cp
	<u>CURVE 1</u>
53.65	2.112×10^{-2}
56.69	2.397
57.89	2.513
61.01	2.834
65.62	3.313
70.32	3.818
74.86	4.314
82.19	5.125
86.30	5.579
94.60	6.505
104.82	7.626
114.53	8.654
124.39	9.682
135.56	1.081×10^{-1}
145.35	1.176
155.75	1.272
165.58	1.355
175.81	1.438
185.93	1.518
195.84	1.590
206.14	1.659
215.91	1.724
226.20	1.789
235.93	1.846
245.55	1.896
256.18	1.952
266.31	2.000
276.22	2.047
286.59	2.089
296.10	2.129*
298.15	2.137

* Not shown on plot

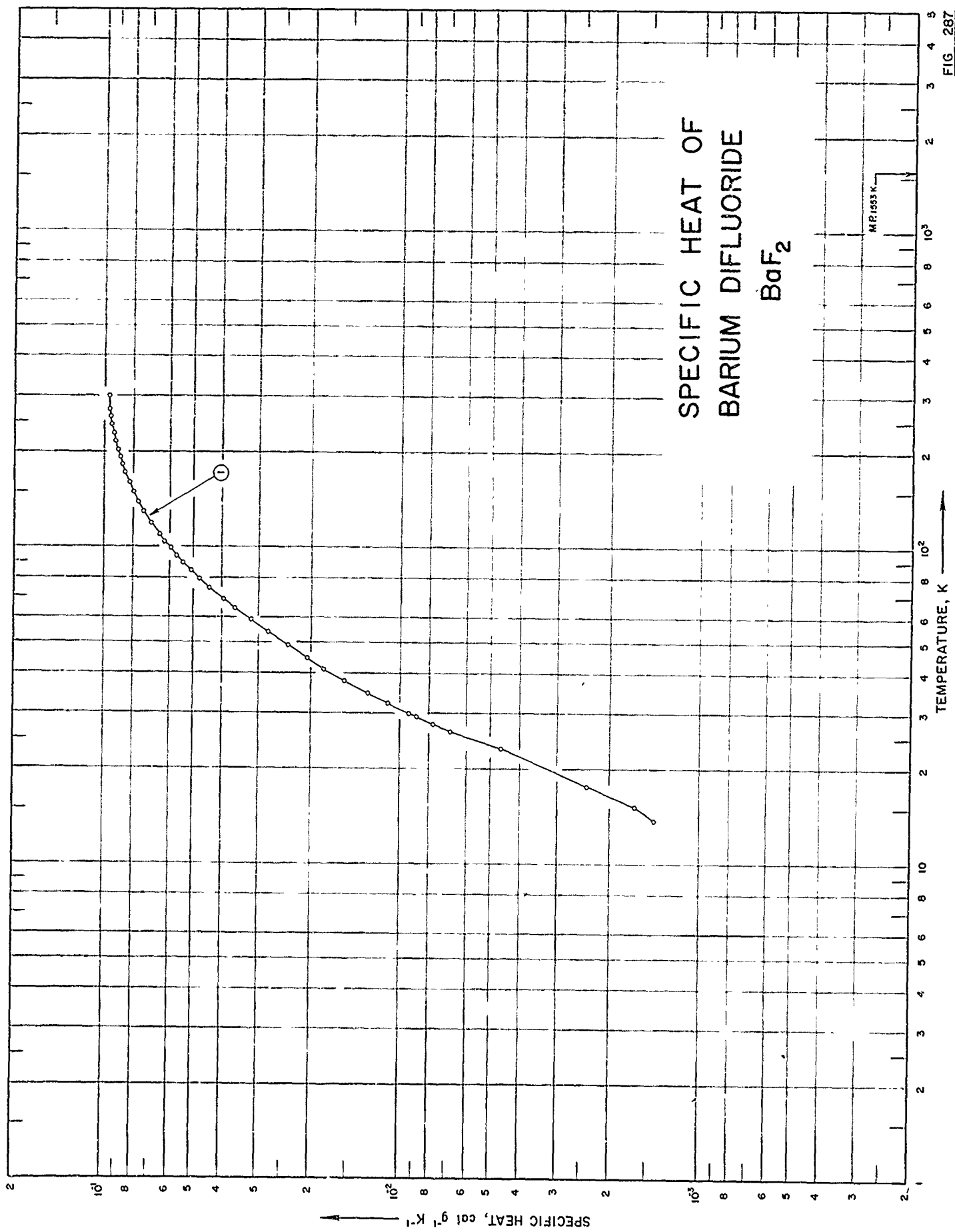

FIG. 287

SPECIFICATION TABLE NO. 287 SPECIFIC HEAT OF BARIUM DIFLUORIDE BaF₂

[For Data Reported in Figure and Table No. 287.]

Curve No.	Rel. No.	Year	Temp. Range, K	Reported Error, %	Name and Specimen Designation	Composition (weight percent), Specifications and Remarks
1	280	1938	14-301			99.7 ± 0.5 Ba; crystalline; prepared by melting C. P. barium nitrate and potassium fluoride in a platinum crucible.

DATA TABLE NO. 287 SPECIFIC HEAT OF BARIUM DIFLUORIDE BaF₂[Temperature, T, K; Specific Heat, Cp, Cal g⁻¹k⁻¹]

T	Cp	T	Cp
13.79	1.426 x 10 ⁻³	203.93	9.040 x 10 ⁻²
15.25	1.654	210.14	9.103*
17.72	2.395	216.91	9.205
23.23	5.133	223.27	9.251*
26.20	6.844	229.73	9.308
27.70	7.814	237.32	9.405*
29.35	8.897	244.95	9.479
30.00	9.410	252.69	9.513*
32.43	1.118 x 10 ⁻²	259.32	9.559
34.73	1.295	266.35	9.587*
38.08	1.551	272.87	9.633
41.45	1.814	273.94	9.644*
44.96	2.065	279.44	9.639*
49.20	2.395	293.08	9.639*
54.24	2.795	300.69	9.684
59.34	3.200		
64.36	3.616		
64.64	3.639*		
68.65	3.958		
74.76	4.443		
79.83	4.768		
84.72	5.099		
89.48	5.412		
94.41	5.698		
99.52	5.954		
104.78	6.262		
110.11	6.542		
115.03	6.763*		
119.76	6.952		
124.79	7.165*		
130.01	7.363		
134.94	7.540*		
139.63	7.694		
144.10	7.785*		
149.75	7.990		
155.28	8.104*		
160.66	8.218		
166.14	8.338*		
173.17	8.509		
177.59	8.560*		
178.32	8.628*		
183.31	8.709		
188.17	8.777*		
193.05	8.863		
198.09	8.926*		

* Not shown on plot

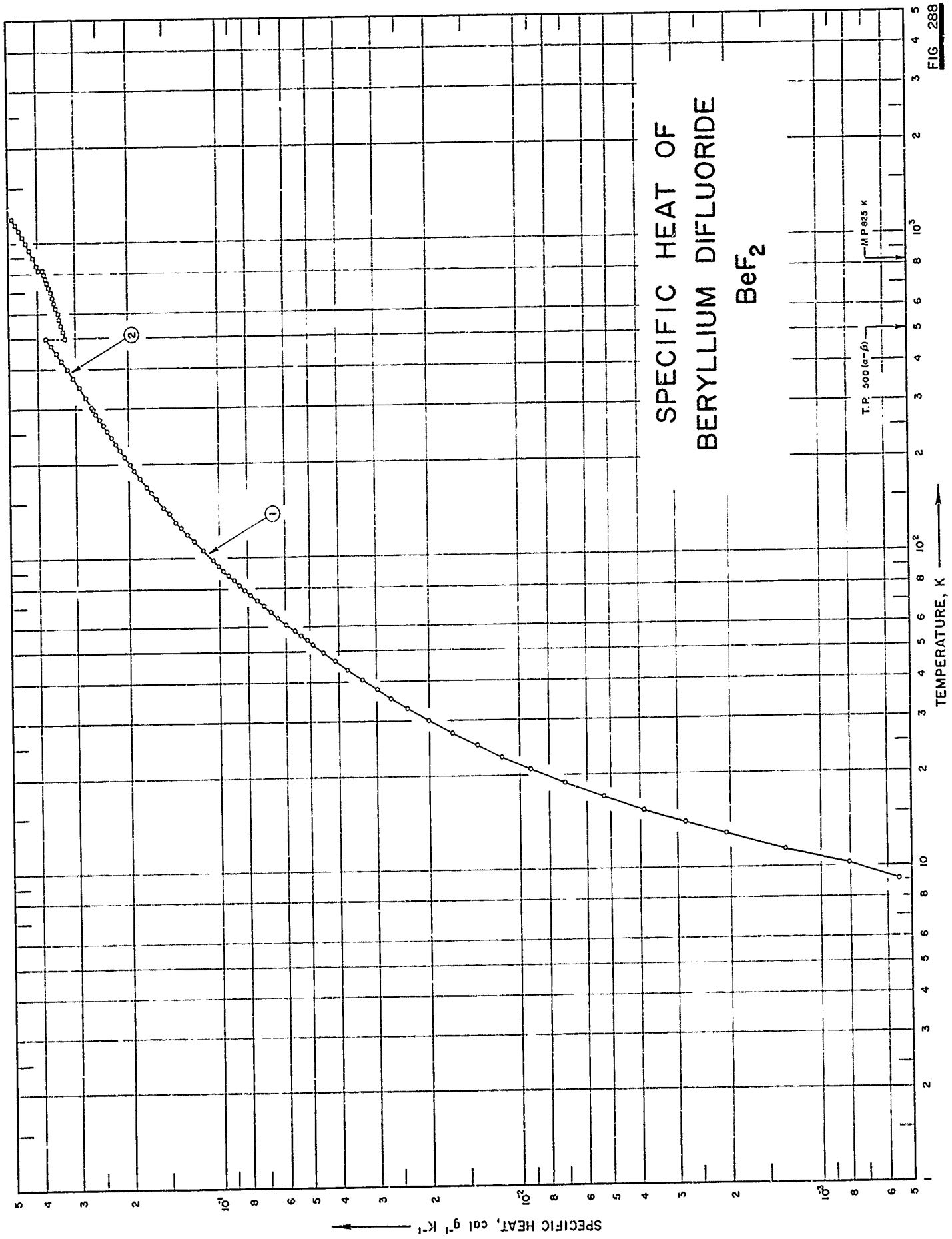

FIG 288

SPECIFICATION TABLE NO. 288 SPECIFIC HEAT OF BERYLLIUM DIFLUORIDE BeF₂

[For Data Reported in Figure and Table No. 288]

Curve No.	Ref. No.	Year	Temp. Range, K	Reported Error, %	Name and Specimen Designation	Composition (weight percent), Specifications and Remarks
1	281	1965	8-304	< 0.3		78.8 ± 2.0 F and 19.9 ± 1.0 Be (80.83 and 19.17 theo.), 0.3 O ₂ , and 0.06 BeO; crystalline.
2	281	1965	298-1200	0.2		0.35 BeO; glassy form; prepared by heating crystalline BeF ₂ to 600 C.

DATA TABLE NO. 288 SPECIFIC HEAT OF BERYLLIUM DIFLUORIDE BeF₂[Temperature, T, K; Specific Heat, Cp, Cal g⁻¹K⁻¹]

T	CURVE 1		CURVE 1 (cont.)		T	CURVE 1 (cont.)		T	CURVE 2		T	CURVE 2 (cont.)	
	Cp	$\times 10^{-3}$	Cp	$\times 10^{-1}$		Cp	$\times 10^{-1}$		Cp	$\times 10^{-1}$		Cp	$\times 10^{-1}$
7.90	4.0	$\times 10^{-3}$	106.83	1.143×10^{-1}	243.54	2.2834	$\times 10^{-1}$	850	4.010	$\times 10^{-1}$	850	4.010	$\times 10^{-1}$
9.10	5.5		109.96	1.177*	247.31	2.3183*		900	4.127		900	4.127	
10.23	8.1		113.18	1.211	250.95	2.3419*		950	4.244		950	4.244	
11.48	1.3	$\times 10^{-3}$	116.39	1.245*	255.03	2.3700		1000	4.361		1000	4.361	
12.82	2.1		119.59	1.279	259.04	2.3949*		1050	4.478		1050	4.478	
14.00	2.83		122.84	1.311*	261.61	2.4104*		1100	4.595		1100	4.595	
15.36	3.89		126.05	1.344	265.55	2.4368		1150	4.712		1150	4.712	
17.01	5.28		129.19	1.376*	269.44	2.4600*		1200	4.829		1200	4.829	
18.92	7.11		131.56	1.399	273.30	2.4859*							
20.91	9.27		132.26	1.406*	277.11	2.5080							
22.95	1.16	$\times 10^{-2}$	135.41	1.437*	280.88	2.5312*							
25.06	1.39		138.70	1.469	284.71	2.5553*							
27.45	1.68		140.18	1.482*	288.60	2.5795							
30.16	2.02		142.05	1.501*	292.44	2.6018*							
32.89	2.372		144.59	1.523*	296.25	2.6231*							
35.44	2.697		145.44	1.531	300.04	2.6450*							
37.83	2.999		148.24	1.557*	303.79	2.6674							
40.75	3.365		151.82	1.589*									
43.95	3.765		155.39	1.621									
46.89	4.135		158.95	1.652*									
49.79	4.512		162.51	1.684									
52.87	4.905		166.17	1.715*									
54.56	5.114		169.82	1.746									
55.97	5.293*		173.36	1.776*									
56.64	5.376		176.85	1.805*									
58.64	5.629		180.34	1.833									
58.83	5.661*		183.68	1.860*									
61.44	5.997		187.38	1.889*									
61.51	6.007*		191.44	1.922									
64.51	6.390		195.61	1.953*									
67.53	6.767		199.09	1.981									
70.52	7.135		202.52	2.006*									
73.48	7.501		205.91	2.030*									
76.42	7.873		207.71	2.045*									
79.26	8.226		211.16	2.069									
82.02	8.575		214.74	2.096*									
85.02	8.943		218.28	2.122*									
88.23	9.337		221.77	2.1453									
91.37	9.700		225.30	2.1707*									
94.45	1.005	$\times 10^{-1}$	228.88	2.1943*									
96.52	1.028*		232.29	2.2175									
97.51	1.039*		235.87	2.2411*									
98.68	1.053		239.63	2.2670*									
100.58	1.073*		239.73	2.2674*									
103.68	1.108*		243.10	2.2911									

* Not shown on plot

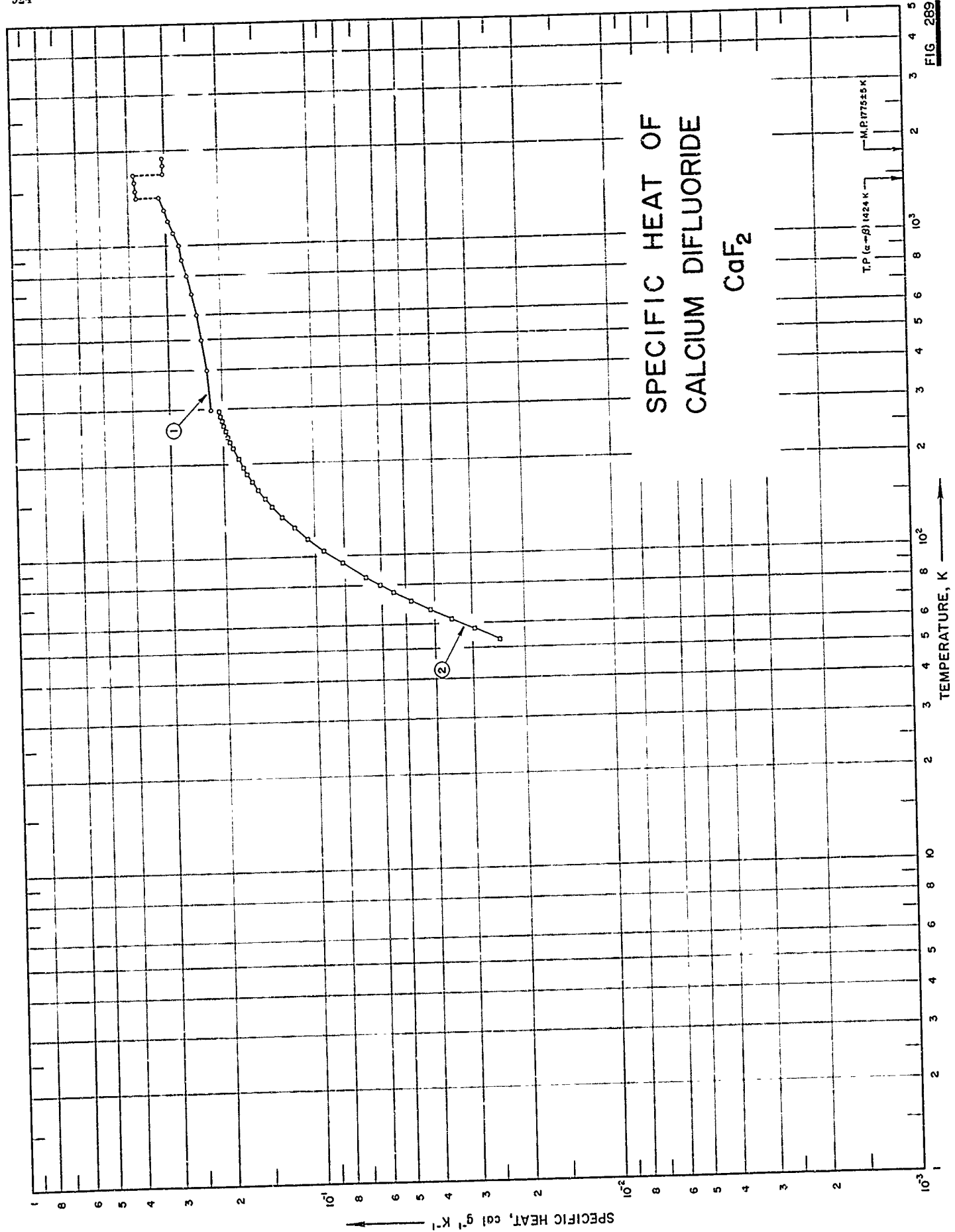

FIG 289

SPECIFICATION TABLE NO. 289 SPECIFIC HEAT OF CALCIUM DIFLUORIDE CaF_2

[For Data Reported in Figure and Table No. 289]

Curve No.	Ref. No.	Year	Temp. Range, K	Reported Error, %	Name and Specimen Designation	Composition (weight percent), Specifications and Remarks
1	282	1945	298-1800			51.27 Ca.
2	283	1949	54-297	0.1-0.3		51.27 Ca (51.33 theo.); large natural fluorite crystals.

DATA TABLE NO. 289 SPECIFIC HEAT OF CALCIUM DIFLUORIDE CaF_2 [Temperature, T, K; Specific Heat, Cp, Cal $\text{g}^{-1}\text{K}^{-1}$]

T	CURVE 1		CURVE 2 (cont.)	
	Cp	T	Cp	T
298.15	2.177×10^{-1}	226.2	1.856×10^{-1}	
300	2.178*	236.4	1.895	
400	2.242	245.8	1.926	
500	2.322	256.3	1.958	
600	2.408	266.0	1.985	
700	2.496	276.0	2.008	
800	2.587	286.4	2.029	
900	2.678	296.5	2.049	
1000	2.770			
1100	2.862			
1200	2.954			
1300	3.047			
1400	3.140*			
α 1424	3.162			
β 1424	3.762			
1500	3.786			
1600	3.818			
β 1691	3.847			
(θ)1691	3.058			
1700	3.058			
1800	3.058			

CURVE 2	
Cp	T
53.51	2.444×10^{-2}
57.55	2.957
62.04	3.532
66.74	4.166
71.40	4.819
76.25	5.507
80.43	6.094
85.32	6.782
95.04	8.115
104.51	9.366
114.48	1.059×10^{-1}
124.37	1.171
135.5	1.288
146.0	1.383
155.6	1.463
165.9	1.541
175.7	1.609
186.0	1.670
195.9	1.719
208.2	1.778
216.4	1.817*

* Not shown on plot

SPECIFIC HEAT OF CERIUM TRIFLUORIDE CeF₃

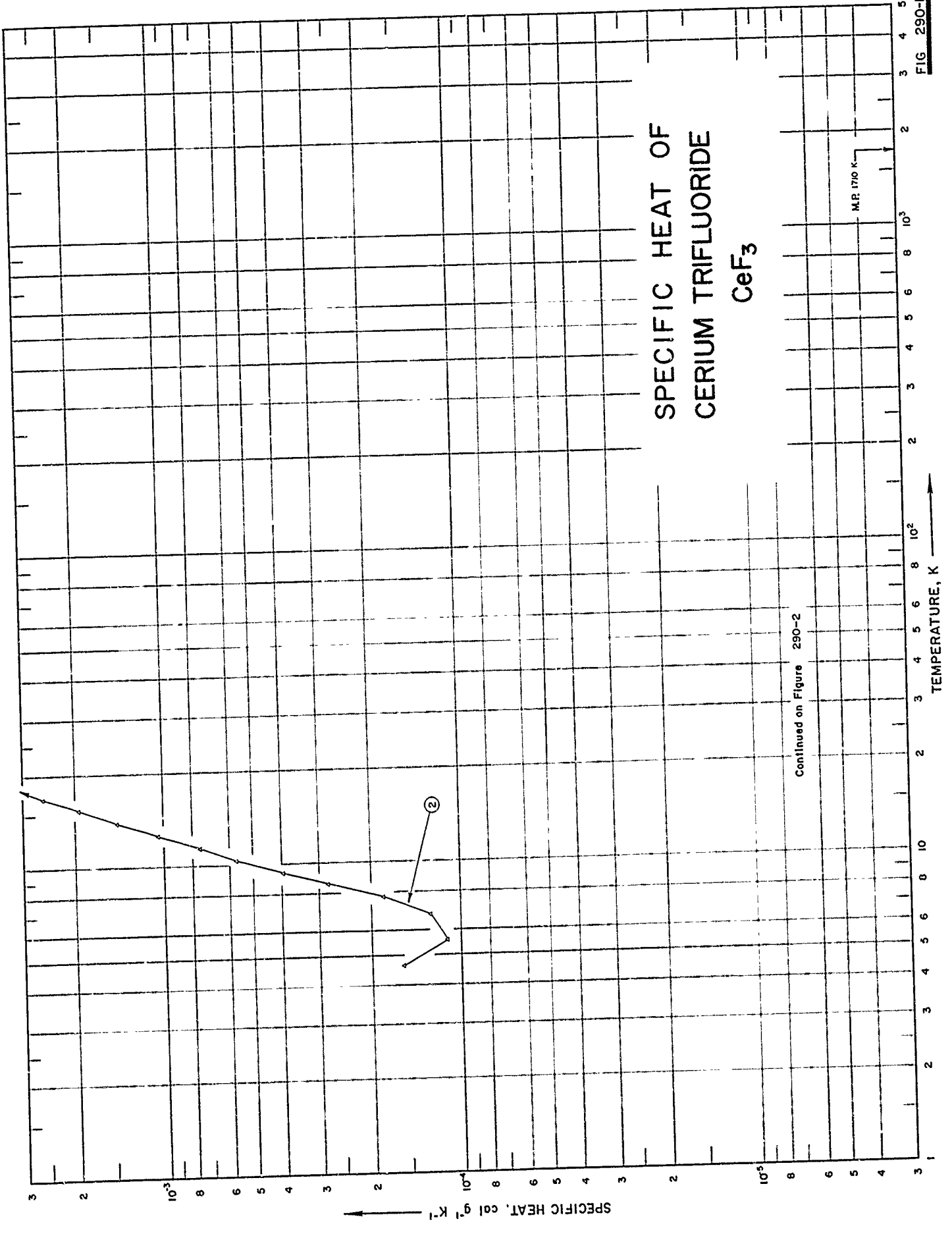

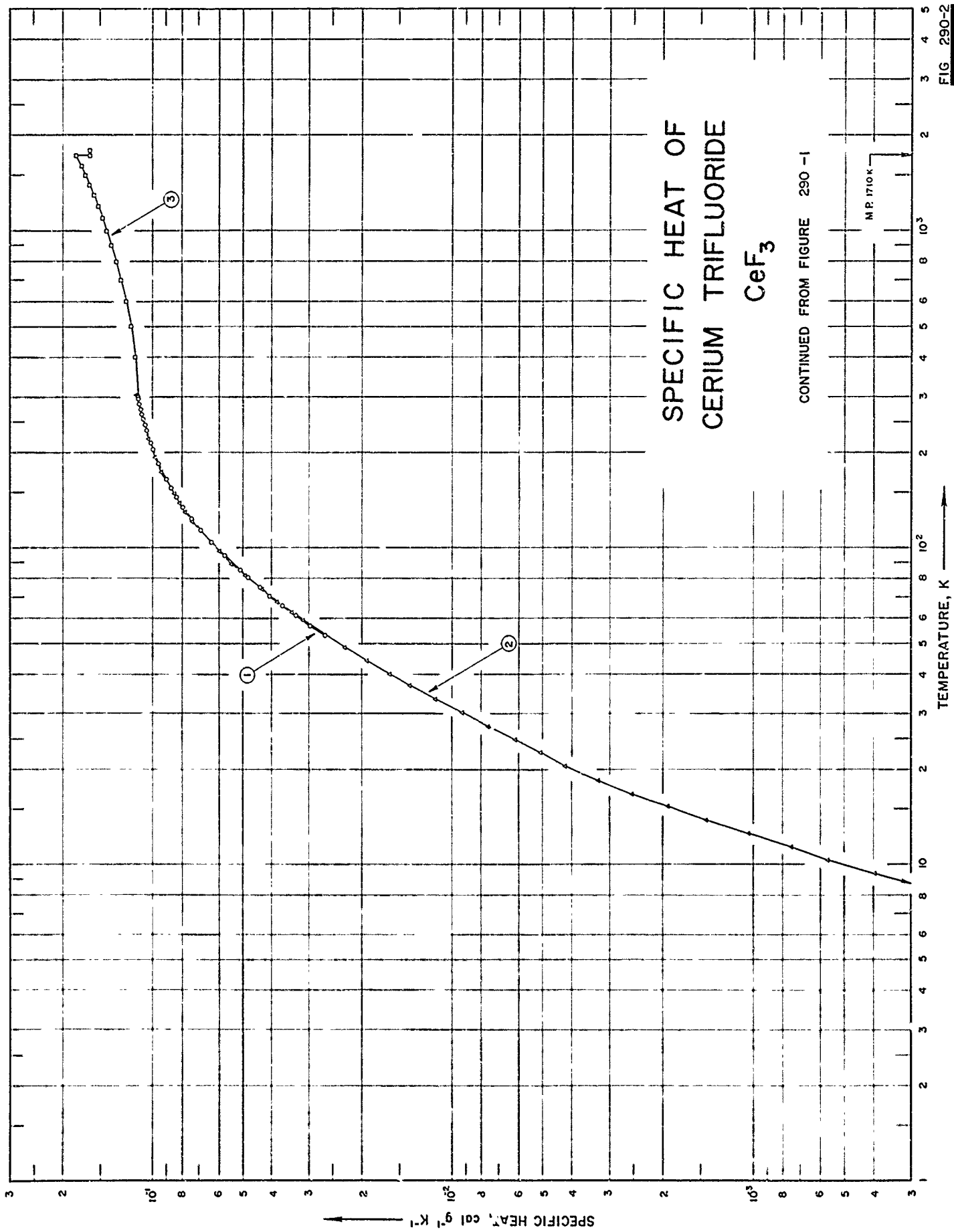

FIG 290-2

SPECIFICATION TABLE NO. 290 SPECIFIC HEAT FOR CERIUM TRIFLUORIDE CeF_3

[For Data Reported in Figure and Table No. 290]

Curve No.	Ref. No.	Year	Temp. Range, K	Reported Error, %	Name and Specimen Designation	Composition (weight percent), Specifications and Remarks
1	284	1959	53-296	0.1-0.5		71.14 Ce, 28.87 F, <0.1 Na, 0.01 Ti, <0.01 Ca, <0.01 K, and 0.001 Mg; heated for 25 hrs at 700 C.
2	285	1961	5-304	0.1-10		71.12 Ce, and 28.88 F; prepared by addition of HF to ceric ammonium nitrate solution; precipitate dried at 110 C and ignited; heated at 500 C in the presence of HF gas.
3	284	1959	298-1800	0.1-0.5		71.14 Ce, 28.87 F, <0.1 Na, 0.01 Ti, <0.01 each Ca and K, and 0.001 Mg; heated for 25 hrs at 700 C.

FIG. 291

SPECIFIC HEAT OF CESIUM MONOHYDROGEN DIFLUORIDE CsHF2

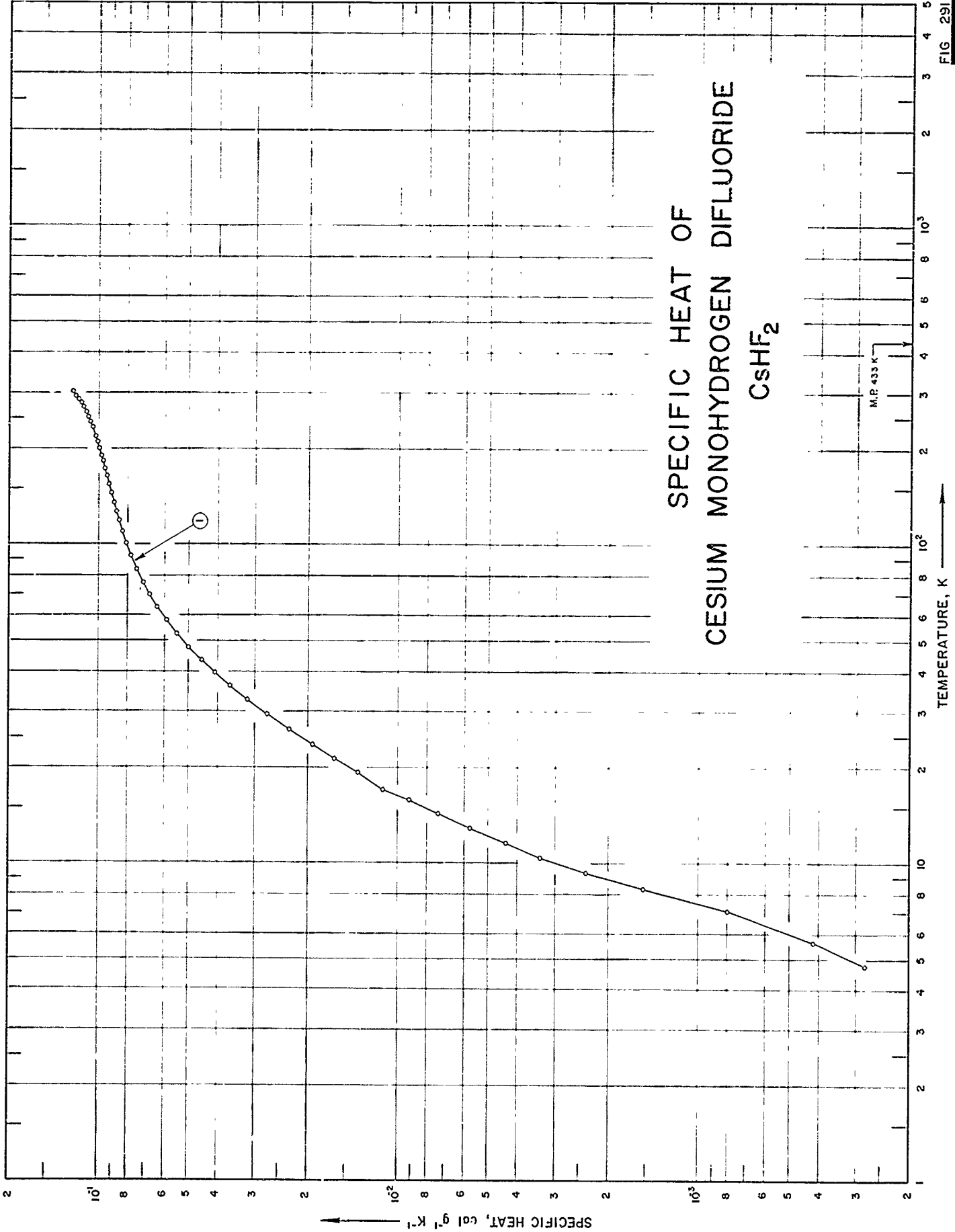

SPECIFICATION TABLE NO. 291 SPECIFIC HEAT OF CESIUM MONOHYDROGEN DIFLUORIDE CsHF_2

[For Data Reported in Figure and Table No. 291]

Curve No.	Ref. No.	Year	Temp. Range, K	Reported Error, %	Name and Specimen Designation	Composition (weight percent), Specifications and Remarks
1	286	1961	5-303			< 0.1 Ca, Mg, and Na; prepared from > 99.5 Cs_2CO_3 ; heated 24 hrs at 300 C.

DATA TABLE NO. 391 SPECIFIC HEAT OF CESIUM MONOHYDROGEN DIFLUORIDE CsHF_2
 [Temperature, T, K; Specific Heat, Cp, Cal $\text{g}^{-1}\text{K}^{-1}$]

T	Cp	T	Cp
<u>CURVE 1</u>			
Series 1			
58.01	5.945×10^{-2}	10.45	3.362×10^{-3}
57.93	5.939*	11.62	4.386
63.79	6.393	12.91	5.753
69.83	6.771	14.31	7.364
76.16	7.137	15.82	9.190
83.91	7.498	17.18	1.125×10^{-2}
92.31	7.829	19.33	1.362
101.20	8.108	21.39	1.638
110.08	8.353	23.69	1.931
119.07	8.574	26.33	2.314
118.34	8.556*	29.35	2.730
127.28	8.760	32.61	3.178
136.21	8.940	36.01	3.631
145.54	9.121	39.65	4.091
155.09	9.299	43.51	4.540
164.38	9.435	47.84	5.013
173.53	9.586	52.78	5.494
182.71	9.725		
191.83	9.865		
201.06	1.001×10^{-1}		
210.13	1.016		
218.96	1.029		
198.58	9.970×10^{-2} *		
207.46	1.011×10^{-1} *		
216.36	1.025*		
225.29	1.040*		
234.28	1.056		
243.30	1.075		
252.31	1.090		
261.25	1.109		
270.05	1.129		
278.70	1.151		
287.00	1.175		
291.91	1.201		
302.74	1.231		
<u>CURVE 1 (cont.)</u>			
Series 2			
4.76	2.792×10^{-4}		
5.65	4.188		
7.10	8.027		
8.32	1.536×10^{-3}		
9.36	2.379		

* Not shown on plot

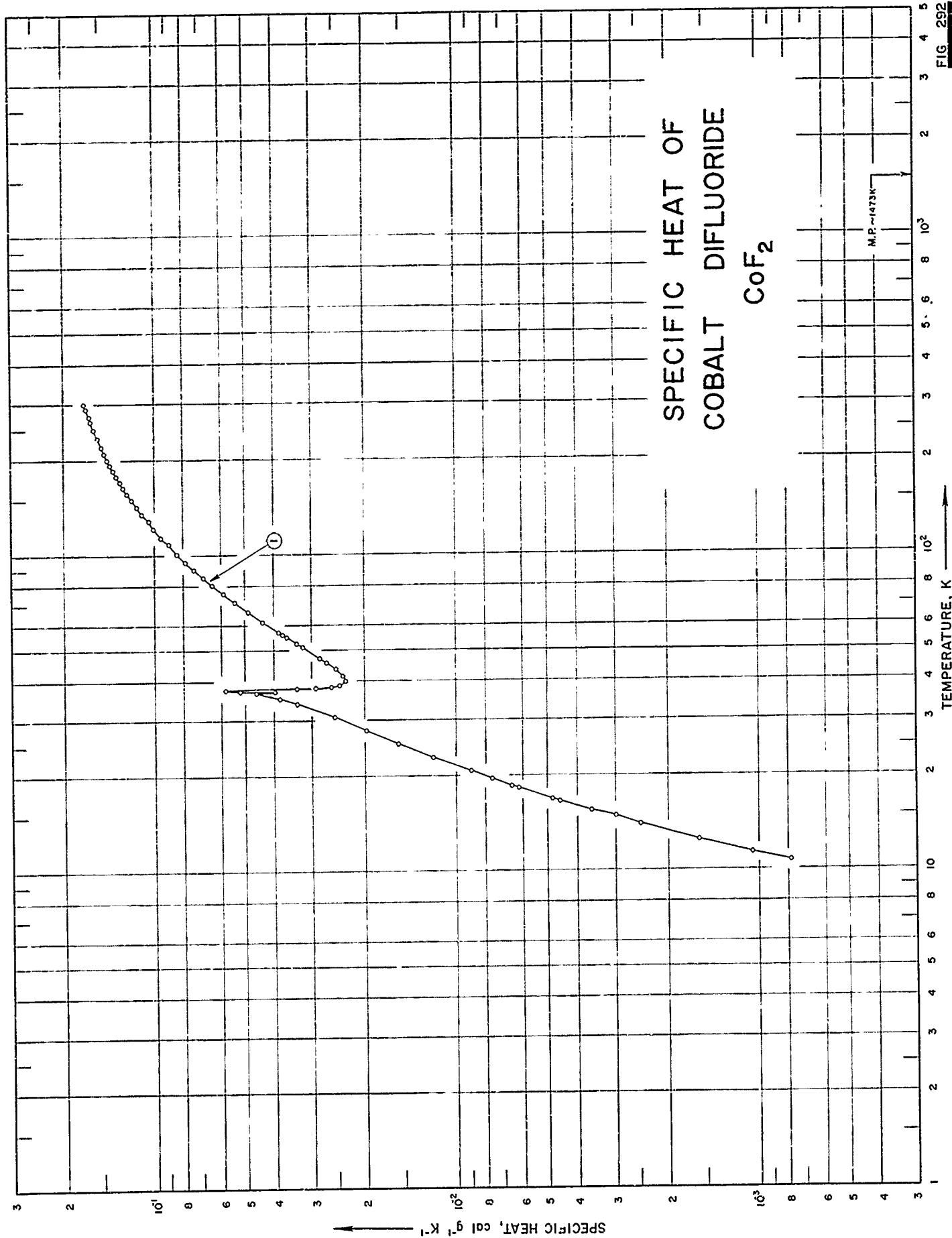

FIG. 292

SPECIFICATION TABLE NO. 292 SPECIFIC HEAT OF COBALT DIFLUORIDE CoF_2

[For Data Reported in Figure and Table No. 292]

Curve No.	Ref. No.	Year	Temp. Range, K	Reported Error, %	Name and Specimen Designation	Composition (weight percent), Specifications and Remarks
1	287	1955	11-302	0.5		60.805 Co (60.80 theo.), 0.04 Fe, 0.005 Si, 0.004 Mg, 0.003 Ni, 0.002 Mn, 0.001 Al, and Cu; prepared from commercial sodium cobaltinitrite; CoF_2 heated at 750 C in the presence of anhydrous HF.

DATA TABLE NO. 292 SPECIFIC HEAT OF COBALT DIFLUORIDE CoF₂[Temperature, T, K; Specific Heat, Cp, Cal g⁻¹K⁻¹]

T	Cp	T	Cp	T	Cp
CURVE I		CURVE I (cont.)		CURVE I (cont.)	
Series I					
51.92	3.277 x 10 ^{-2*}	10.73	7.840 x 10 ⁻⁴	37.442	5.354 x 10 ^{-2*}
56.38	3.769	11.41	1.082 x 10 ⁻³	37.517	5.529*
61.78	4.374	12.58	1.589	37.590	5.725*
66.41	4.893	14.80	2.992	37.661	5.828
		16.64	4.549	37.730	5.787*
		18.65	6.581	37.802	5.694*
		20.71	8.954	37.869	4.353*
		22.97	1.197 x 10 ⁻²	37.969	3.363
		25.36	1.559	38.086	2.930
		27.92	1.991	38.217	2.723*
		30.73	2.538	38.373	2.600
		33.99	3.368	38.534	2.507*
		37.01	3.986	38.697	2.455*
		42.27	2.435*	38.863	2.424*
		47.48	2.826	39.029	2.393*
		51.32	3.217	39.257	2.363*
		55.28	3.646		
Series II					
52.71	3.364 x 10 ⁻²				
57.34	3.871				
62.80	4.489*				
67.09	4.970*				
71.24	5.418				
75.69	5.898				
80.50	6.403				
85.19	6.888				
90.19	7.375				
95.61	7.866				
101.57	8.394				
107.97	8.930				
114.61	9.458				
128.45	1.048 x 10 ⁻¹				
135.88	1.097				
143.27	1.144				
150.40	1.186				
157.44	1.226				
164.66	1.264				
171.34	1.306				
178.75	1.351				
186.40	1.365				
194.09	1.396				
201.52	1.426				
211.02	1.460				
218.92	1.486				
226.57	1.511*				
235.08	1.537				
242.70	1.558*				
250.90	1.581				
258.63	1.602*				
265.97	1.623				
Series III					
		10.73	7.840 x 10 ⁻⁴		
		11.41	1.082 x 10 ⁻³		
		12.58	1.589		
		14.80	2.992		
		16.64	4.549		
		18.65	6.581		
		20.71	8.954		
		22.97	1.197 x 10 ⁻²		
		25.36	1.559		
		27.92	1.991		
		30.73	2.538		
		33.99	3.368		
		37.01	3.986		
		42.27	2.435*		
		47.48	2.826		
		51.32	3.217		
		55.28	3.646		
Series IV					
		14.06	2.476 x 10 ⁻³		
		15.54	3.580		
		16.98	4.828		
		18.33	6.220		
		19.61	7.644		
Series V					
		34.19	3.399 x 10 ^{-2*}		
		35.42	3.837		
		36.19	4.187*		
		37.35	5.215		
		37.99	3.887*		
		38.88	2.438		
		40.10	2.329		
		41.72	2.371		
		43.77	2.502		
		45.92	2.682		
Series VI					
		37.442	5.354 x 10 ^{-2*}		
		37.517	5.529*		
		37.590	5.725*		
		37.661	5.828		
		37.730	5.787*		
		37.802	5.694*		
		37.869	4.353*		
		37.969	3.363		
		38.086	2.930		
		38.217	2.723*		
		38.373	2.600		
		38.534	2.507*		
		38.697	2.455*		
		38.863	2.424*		
		39.029	2.393*		
		39.257	2.363*		
Series VII					
		37.694	5.808 x 10 ^{-2*}		
		37.768	5.746*		
		37.850	4.642*		
Series VIII					
		275.45	1.642 x 10 ⁻¹		
		283.33	1.661*		
		291.79	1.678		
		299.89	1.702*		
		122.34	1.004		
		273.64	1.643*		
		301.64	1.704		

* Not shown on plot

SPECIFIC HEAT OF HAFNIUM TETRAFLUORIDE HfF₄

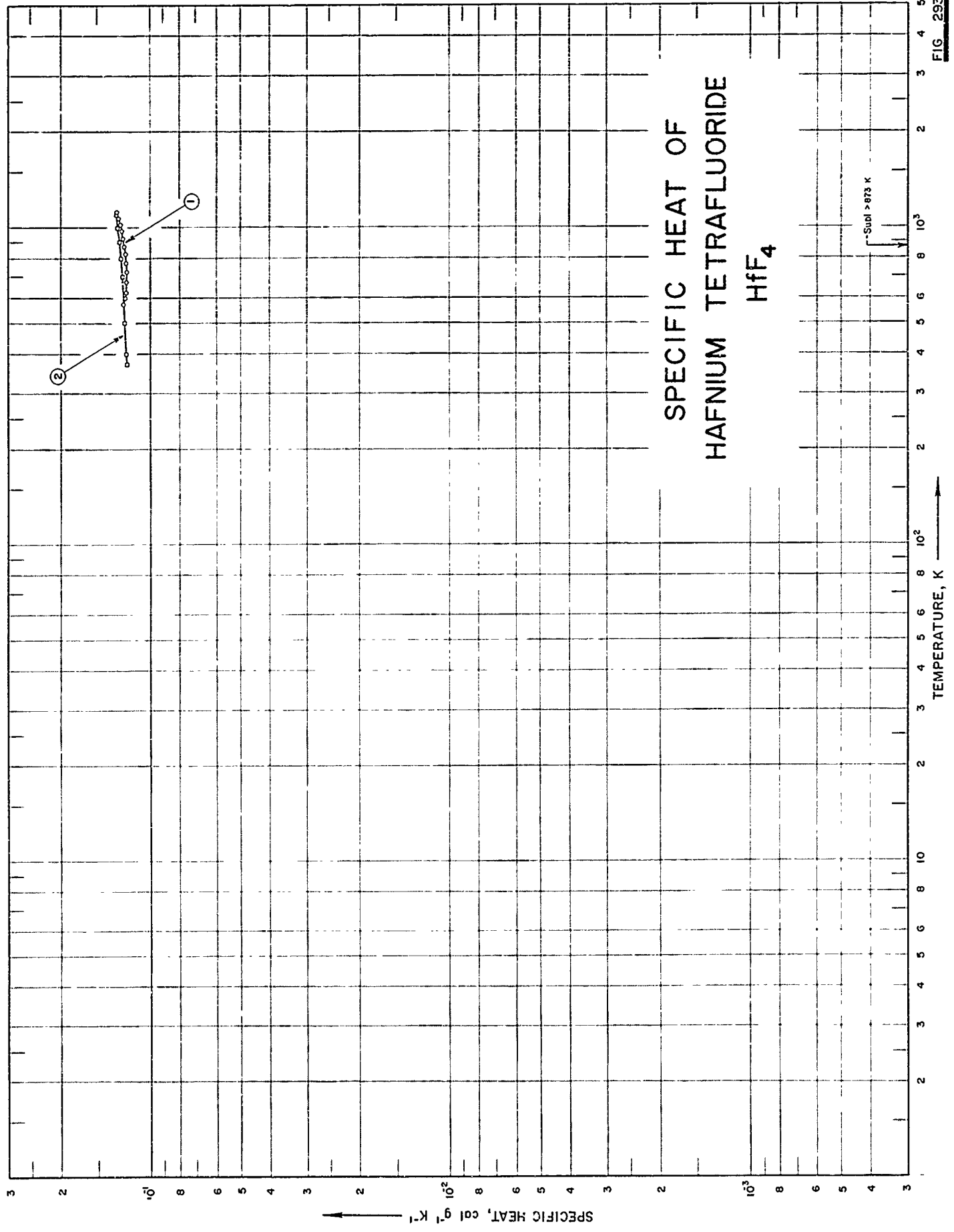

SPECIFIC HEAT, cal g⁻¹ K⁻¹ →

TEMPERATURE, K →

②
①

T_m (Solid) > 873 K

SPECIFICATION TABLE NO. 293 SPECIFIC HEAT OF HAFNIUM TETRAFLUORIDE HfF_4

[For Data Reported in Figure and Table No. 293]

Curve No.	Ref. No.	Year	Temp. Range, K	Reported Error, %	Name and Specimen Designation	Composition (weight percent), Specifications and Remarks
1	251	1958	575-1125			1.0 Zr.
2	252	1961	370-1105			99.0 HfF_4 , 1.0 Zr, and traces of Mg, Al, V, and Fe.

DATA TABLE NO. 293 SPECIFIC HEAT OF HAFNIUM TETRAFLUORIDE HfF₄[Temperature, T, K; Specific Heat, Cp, Cal g⁻¹K⁻¹]

T	Cp
<u>CURVE 1</u>	
575	1.224 x 10 ⁻¹
600	1.215
625	1.208
650	1.203*
675	1.201
700	1.199*
725	1.199
750	1.201*
775	1.203
800	1.206*
825	1.210
850	1.215*
875	1.220
900	1.226*
925	1.233
950	1.240*
975	1.247
1000	1.254*
1025	1.262
1050	1.271*
1075	1.279
1100	1.288*
1125	1.297
<u>CURVE 2</u>	
370	1.198 x 10 ⁻¹
400	1.202
500	1.215
600	1.228*
700	1.241
800	1.254
900	1.267
1000	1.280
1105	1.294

* Not shown on plot

SPECIFIC HEAT OF
IRON DIFLUORIDE
 FeF_2

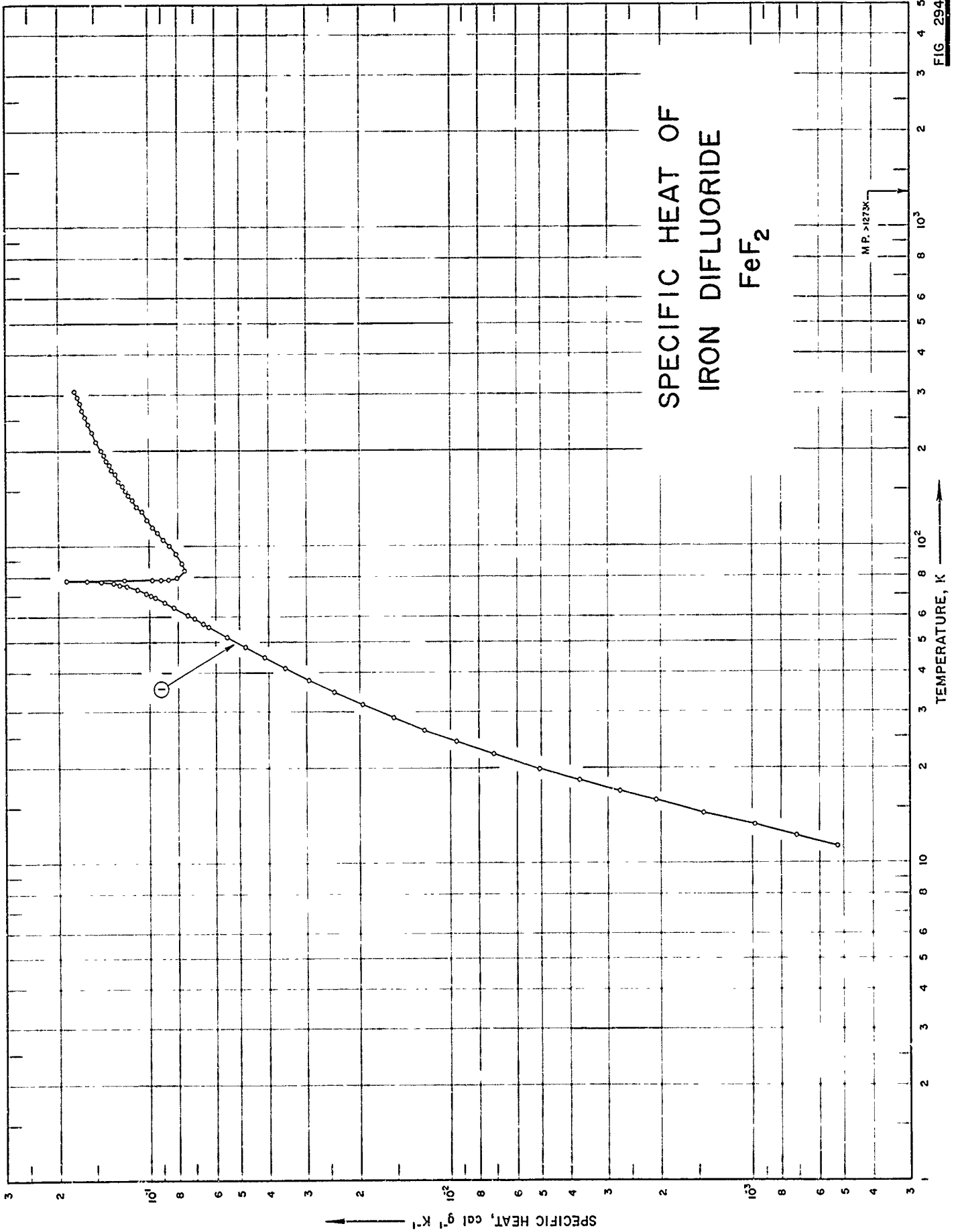

FIG. 294

SPECIFICATION TABLE NO. 294 SPECIFIC HEAT OF IRON DIFLUORIDE FeF_2

[For Data Reported in Figure and Table No. 294]

Curve No.	Ref. No.	Year	Temp. Range, K	Reported Error, %	Name and Specimen Designation	Composition (weight percent). Specifications and Remarks
1	287	1955	11-307	0.5		59.47 Fe (59.51 theo.), 0.005 V, 0.004 Al, and 0.001 each Mn, Mg, and Ni; prepared from FeCl_2 ; FeCl_2 heated in HF atmosphere at 1050 C.

DATA TABLE NO. 294 SPECIFIC HEAT OF IRON DIFLUORIDE FeF₂[Temperature, T, K; Specific Heat, Cp, Cal g⁻¹K⁻¹]

T	CURVE I		CURVE I (cont.)		CURVE I (cont.)	
	T	Cp	T	Cp	T	Cp
Series I						
51.83	5.485 x 10 ⁻² *	57.15	6.579 x 10 ⁻²	149.26	1.193 x 10 ⁻¹	
54.60	6.045*	60.83	7.410	155.58	1.231	
59.34	7.061	64.03	8.159*	161.81	1.264	
64.51	8.285	67.76	8.860	168.27	1.299	
70.15	9.854	69.17	9.531	174.68	1.330	
75.62	1.255 x 10 ⁻¹	71.34	1.022 x 10 ⁻¹	180.99	1.359	
81.71	8.090 x 10 ⁻² *	73.30	1.096	187.47	1.389	
88.44	7.763	75.08	1.185	194.19	1.418	
94.63	8.124	76.67	1.308*	200.91	1.445	
100.46	8.547	78.12	1.375*	207.79	1.472*	
106.20	8.975	79.89	8.056 x 10 ⁻²	214.50	1.496	
111.83	9.393	82.01	7.653*	221.48	1.522*	
116.90	9.770	84.08	7.611	228.50	1.546	
122.40	1.016 x 10 ⁻¹	86.29	7.660*	235.52	1.567*	
128.14	1.057	88.78	7.781*	242.49	1.591	
134.15	1.099	Series IV		249.11	1.611*	
140.19	1.138	76.392	1.277 x 10 ⁻¹ *	255.27	1.626	
146.29	1.175	Series V		261.88	1.643*	
Series II						
11.33	5.219 x 10 ⁻¹	76.566	1.296 x 10 ⁻¹ *	268.58	1.661	
12.28	7.137	77.143	1.362*	275.22	1.681*	
13.25	9.800	77.599	1.442	282.22	1.696	
14.47	1.449 x 10 ⁻³	77.897	1.522*	289.24	1.712*	
15.80	2.077	79.052	1.607	295.91	1.727	
16.95	2.738	78.151	1.668*	307.30	1.760	
18.34	3.739	78.235	1.754*			
19.94	5.060	78.315	1.876			
22.17	7.190	78.411	1.209			
27.29	9.512	78.536	9.718 x 10 ⁻²			
26.14	1.220 x 10 ⁻²	78.617	9.132			
28.88	1.545	78.617	8.801*			
31.73	1.956	78.813	8.578			
34.77	2.427	79.273	8.305*			
37.96	2.948	79.252	8.044*			
41.35	3.526	79.754	7.860*			
44.74	4.134	80.302	7.860*			
48.22	4.784	Series VI				
51.91	5.495	78.202	1.727 x 10 ⁻¹ *			
55.95	6.328	78.279	1.826*			
		78.358	1.593*			

* Not shown on plot

SPECIFIC HEAT OF LITHIUM FLUORIDE LiF

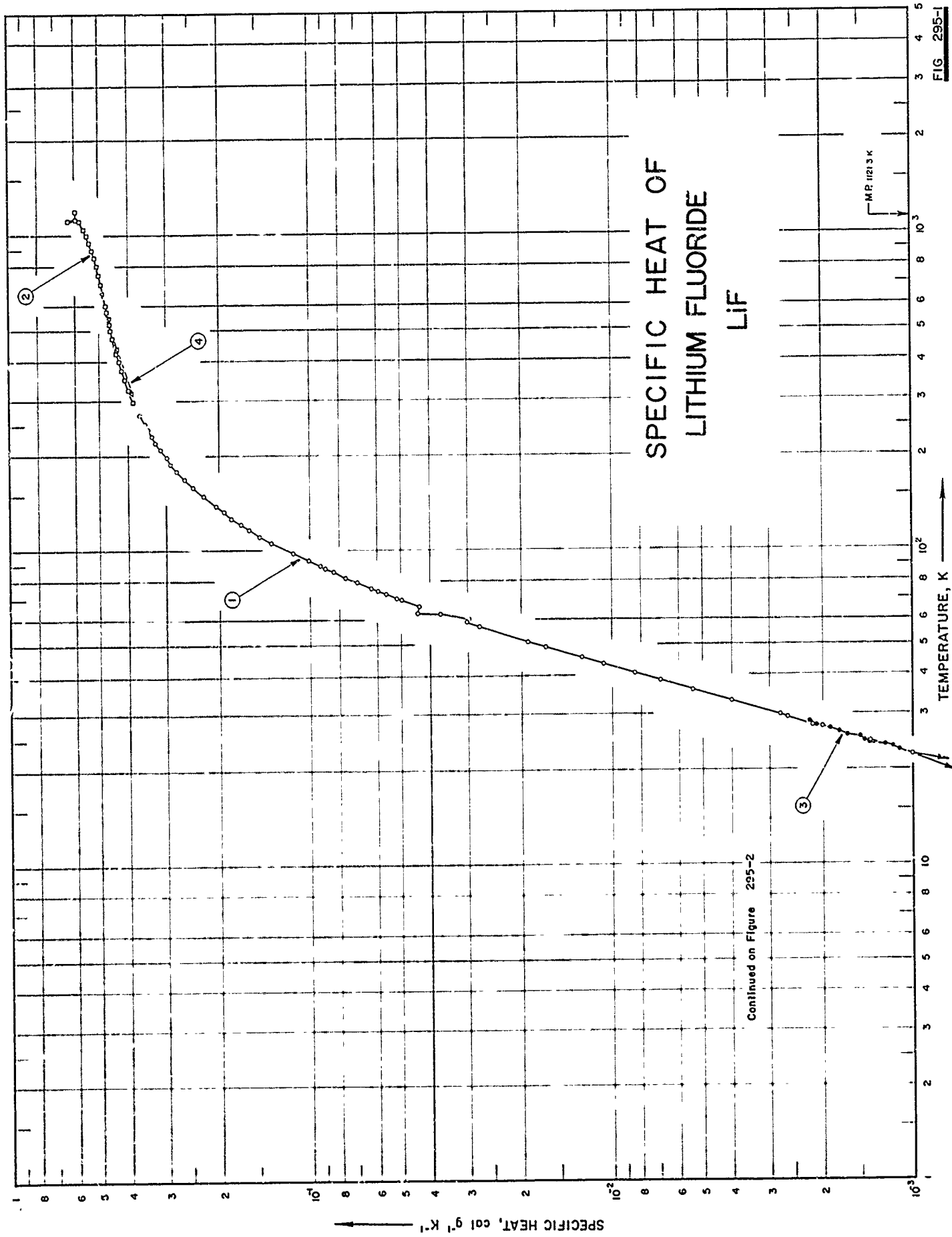

SPECIFIC HEAT, cal g⁻¹ K⁻¹

TEMPERATURE, K

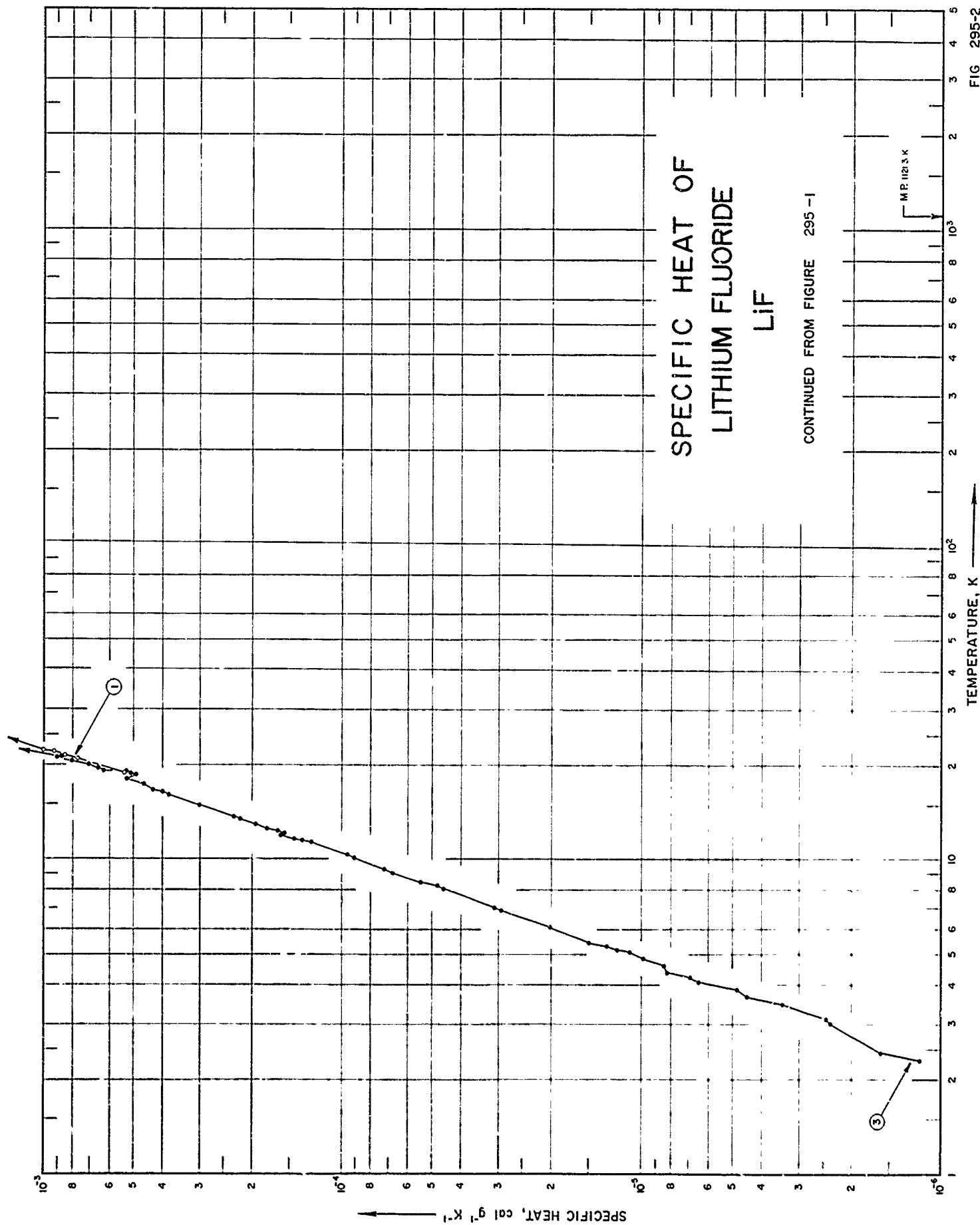

FIG. 295-2

SPECIFICATION TABLE NO. 295 SPECIFIC HEAT OF LITHIUM FLUORIDE LiF

[For Data Reported in Figure and Table No. 295]

Curve No.	Ref. No.	Year	Temp. Range, K	Reported Error, %	Name and Specimen Designation	Composition (weight percent), Specifications and Remarks
1	243	1949	19-272			
2	288	1953	298-1200	0.5		Before test: a few thousandths of 1% each Ca, Mg, Na, and Ni; traces of Al, Cr, Fe, and Si; after test: addition of a few hundredths of 1% Cr and a few thousandths of 1% Al, Mn, and Si; single crystals; sample supplied by the Harshaw Chemical Co; slowly crystallized.
3	289	1955	2-28			
4	328	1956	318-658	± 0.5		Artificial crystal (197 gm).

DATA TABLE NO. 295 SPECIFIC HEAT OF LITHIUM FLUORIDE LiF

[Temperature, T, K; Specific Heat, Cp, Cal g⁻¹K⁻¹]

CURVE 1		CURVE 1 (cont.)		CURVE 2 (cont.)		CURVE 3 (cont.)		CURVE 3 (cont.)	
T	Cp	T	Cp	T	Cp	T	Cp	T	Cp
18.8	5.4 × 10 ⁻³	138.4	2.050 × 10 ⁻¹	700	4.923 × 10 ⁻¹	Series II		25.69	1.650 × 10 ⁻³
19.0	5.4*	143.8	2.154*	750	5.005	Series II		26.28	1.766
20.8	7.710	149.1	2.256	800	5.089	2.31	1.188 × 10 ⁻³	26.95	1.897
21.4	8.481	153.4	2.352*	850	5.177	3.10	2.437	27.69	2.113
22.0	9.252	159.5	2.440	900	5.273	3.67	4.489	28.33	2.213
22.1	1.002 × 10 ⁻³	164.5	2.525*	950	5.376	4.09	6.463		
24.6	1.388	169.6	2.607	1000	5.489	4.37	8.252		
24.8	1.388	174.7	2.658*	1050	5.614	4.59	8.407		
27.3	2.005	179.7	2.760	1100	5.752*	5.20	1.203 × 10 ⁻³		
27.6	2.159	184.6	2.828*		5.815	5.23	1.234	317.69	3.93 × 10 ⁻¹
29.3	2.621	188.9	2.904	(S) 1121.3	6.365	5.34	1.311	319.39	3.96*
29.9	2.776	193.3	2.941*	(I) 1121.3	6.365	5.46	1.481	379.70	4.18*
33.1	4.009	198.6	2.995	1125	5.979	6.90	2.938	439.56	4.36
35.9	5.997	200.5	3.029*	1150	5.979*	6.90	2.938	441.38	4.37*
38.5	6.939	202.7	3.091*	1175	5.979*	12.52	1.782 × 10 ⁻⁴	549.58	4.64
40.7	8.404	210.9	3.145	1200	5.979	12.90	1.959	551.90	4.65*
43.4	1.072 × 10 ⁻²	216.3	3.201*			13.34	2.190	656.01	4.82*
45.5	1.264	221.7	3.261			13.73	2.314	658.02	4.86
49.2	1.665	226.9	3.291*			16.02	3.802		
51.1	1.912	232.0	3.359			16.44	3.995		
57.2	2.753	237.4	3.402*			16.73	4.327		
59.3	3.030	242.5	3.452			18.62	5.923		
60.4	2.984	248.5	3.499*			19.05	6.286		
62.7	3.716	254.0	3.536			21.18	9.024		
63.3	4.410	259.9	3.581*			24.36	1.396 × 10 ⁻³		
66.4	4.364	265.9	3.638*			24.65	1.450		
66.5	4.410*	271.7	3.676						
69.6	4.988								
70.4	5.181								
72.7	5.628								
74.3	5.991								
75.6	6.299								
79.0	6.985								
81.9	7.656								
85.5	8.389								
87.8	8.905								
89.1	9.229								
93.2	1.017 × 10 ⁻¹								
98.3	1.140								
106.9	1.348								
112.1	1.471								
117.2	1.590								
122.4	1.709								
127.6	1.823								
132.9	1.937								

* Not shown on plot

FIG. 296

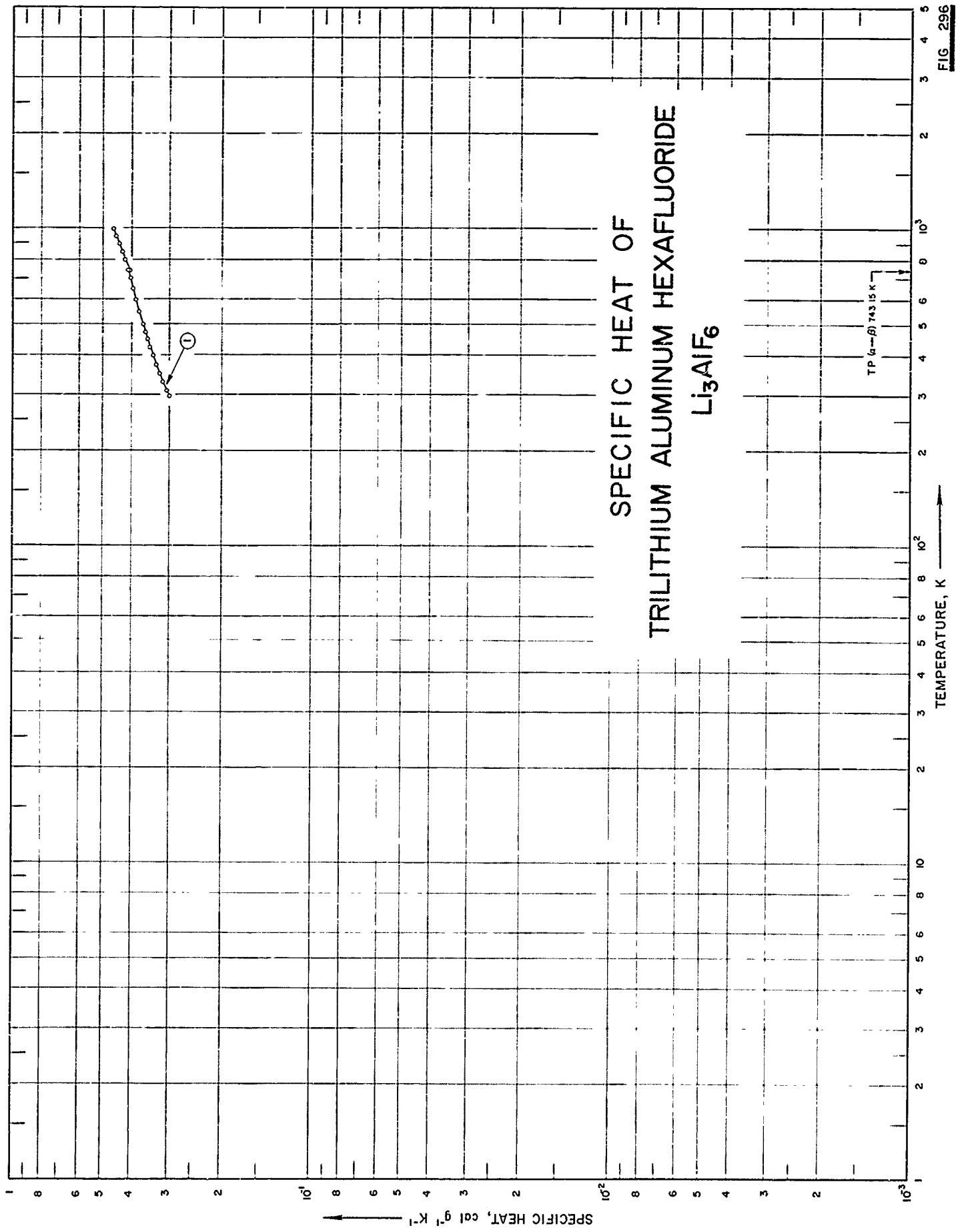

SPECIFICATION TABLE NO. 296 SPECIFIC HEAT OF TRILITHIUM ALUMINUM HEXAFLUORIDE Li_3AlF_6

[For Data Reported in Figure and Table No. 296]

Curve No.	Ref. No.	Year	Temp. Range, K	Reported Error, %	Name and Specimen Designation	Composition (weight percent), Specifications and Remarks
1	170	1964	298-1000			70.43 F, 16.74 Al and 12.92 Li.

DATA TABLE NO. 296 SPECIFIC HEAT OF TRILITHIUM ALUMINUM HEXAFLUORIDE Li_3AlF_6
 [Temperature, T, K; Specific Heat, Cp, Cal g⁻¹K⁻¹]

T	Cp
<u>CURVE 1</u>	
298.15	2.994 x 10 ⁻¹
300	3.003*
310	3.051
320	3.097*
330	3.140
340	3.182*
350	3.221
360	3.259*
370	3.295*
373.15	3.306
380	3.330*
390	3.363
400	3.395
425	3.471
450	3.541
475	3.605
500	3.666
550	3.776
600	3.875
650	3.965
700	4.049
α: 743.15	4.117
β: 743.15	4.099*
750	4.112*
800	4.212
850	4.314
900	4.417
950	4.523
1000	4.630

* Not shown on plot

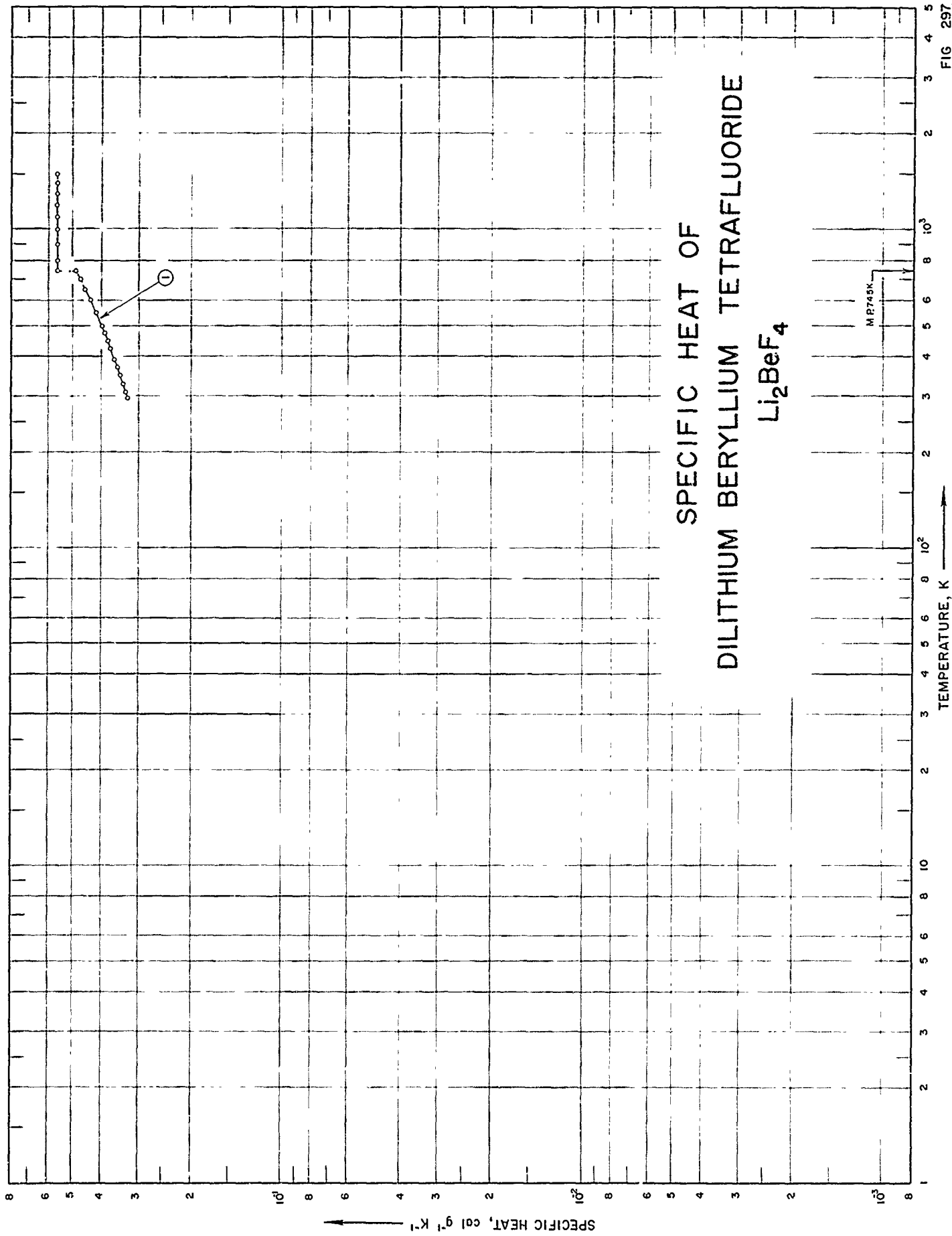

SPECIFIC HEAT OF
DILITHIUM BERYLLIUM TETRAFLUORIDE
 Li_2BeF_4

FIG. 297

SPECIFICATION TABLE NO. 297 SPECIFIC HEAT OF DILITHIUM BERYLLIUM TETRAFLUORIDE Li_2BeF_4

[For Data Reported in Figure and Table No. 297]

Curve No.	Ref. No.	Year	Temp. Range, K	Reported Error, %	Name and Specimen Designation	Composition (weight percent), Specifications and Remarks
1	170	1964	298-1500			76.86 F, 14.03 Li, and 9.11 Be, 0.001-0.01 Ag, Al, Cu, Fe, K, Mn, Na, Si, Ti, and Zr, 0.0001-0.001 Ba, Ni, and Pb.

DATA TABLE NO. 297 SPECIFIC HEAT OF LITHIUM BERYLLIUM TETRAFLUORIDE Li_2BeF_4
 [Temperature, T, K; Specific Heat, Cp, Cal $\text{g}^{-1}\text{K}^{-1}$]

T	Cp
	3.269 x 10 ⁻¹
298.15	3.276*
300	3.312
310	3.348*
320	3.384
330	3.420*
340	3.456
350	3.492*
360	3.529
370	3.540*
373.15	3.565*
380	3.601
390	3.637*
400	3.727
425	3.818
450	3.908
475	3.998
500	4.199
550	4.359
600	4.540
650	4.721
700	4.863
(s)745	5.613
(l)745	5.613*
750	5.613
800	5.613*
850	5.613*
900	5.613*
950	5.613*
1000	5.613
1050	5.613*
1100	5.613
1150	5.613*
1200	5.613
1250	5.613*
1300	5.613
1350	5.613*
1400	5.613
1450	5.613*
1500	5.613

* Not shown on plot

SPECIFIC HEAT OF LITHIUM MONOHYDROGEN DIFLUORIDE LiHF₂

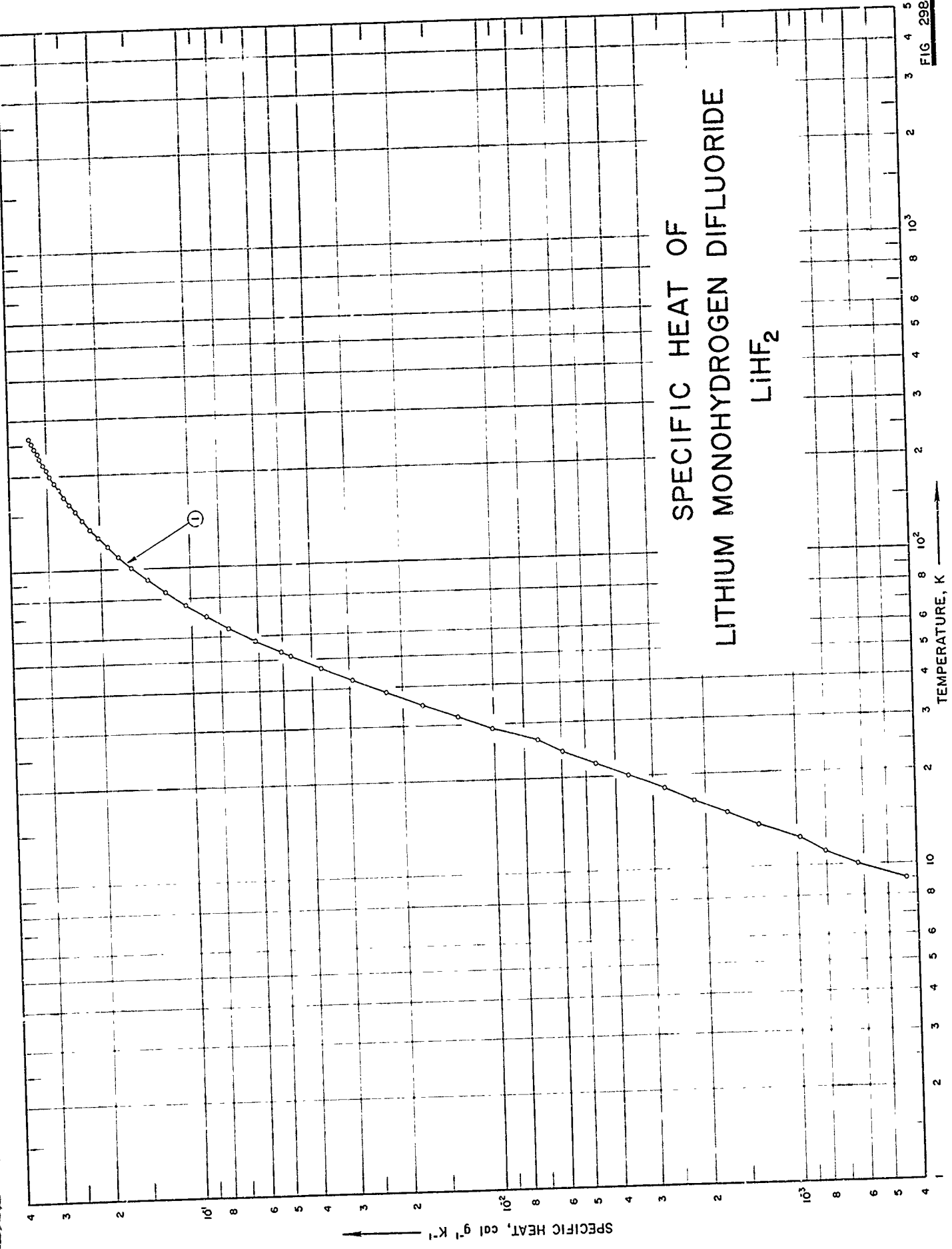

SPECIFICATION TABLE NO. 298 SPECIFIC HEAT OF LITHIUM MONOHYDROGEN DIFLUORIDE LiHF_2

[For Data Reported in Figure and Table No. 298]

Curve No.	Ref. No.	Year	Temp. Range, K	Reported Error, %	Name and Specimen Designation	Composition (weight percent), Specifications and Remarks
1	290	1961	7-301			99.48 LiHF_2 and 0.52 LiF ; prepared by addition of metal carbonate to boiling reagent aqueous 48% HF solution; refrigerated at -10 C .

DATA TABLE NO. 298 SPECIFIC HEAT OF LITHIUM MONOHYDROGEN DIFLUORIDE LiHF_2
 [Temperature, T, K; Specific Heat, Cp, Cal $\text{g}^{-1}\text{K}^{-1}$]

T	Cp	T	Cp
CURVE 1		CURVE 1 (cont.)	
Series I			
109.21	1.730×10^{-1} *	46.81	3.754×10^{-2}
118.45	1.898	51.47	4.716
126.20	2.027	53.04	5.056
134.89	2.163	57.98	6.150
143.98	2.294	63.82	7.513
152.89	2.416	69.90	8.925
161.77	2.527	76.55	1.045×10^{-1}
170.86	2.631	84.12	1.219
180.33	2.734	92.36	1.399
189.93	2.831	101.02	1.574
199.35	2.940	109.74	1.741
208.59	3.010		
217.69	3.090		
226.72	3.171		
235.72	3.230		
244.00	3.293		
253.55	3.356		
262.45	3.419		
271.53	3.480		
281.10	3.543		
291.07	3.608		
301.36	3.674		
Series II			
6.57	1.741×10^{-4}		
7.84	2.829		
9.01	4.353		
10.11	6.311		
11.19	8.053		
12.39	9.794		
13.71	1.349×10^{-3}		
15.10	1.719		
16.53	2.198		
18.18	2.742		
20.07	3.613		
22.01	4.636		
24.13	5.963		
26.54	7.182		
29.08	1.012×10^{-2}		
31.86	1.321		
34.99	1.722		
38.60	2.272		
42.58	2.949		

* Not shown on plot

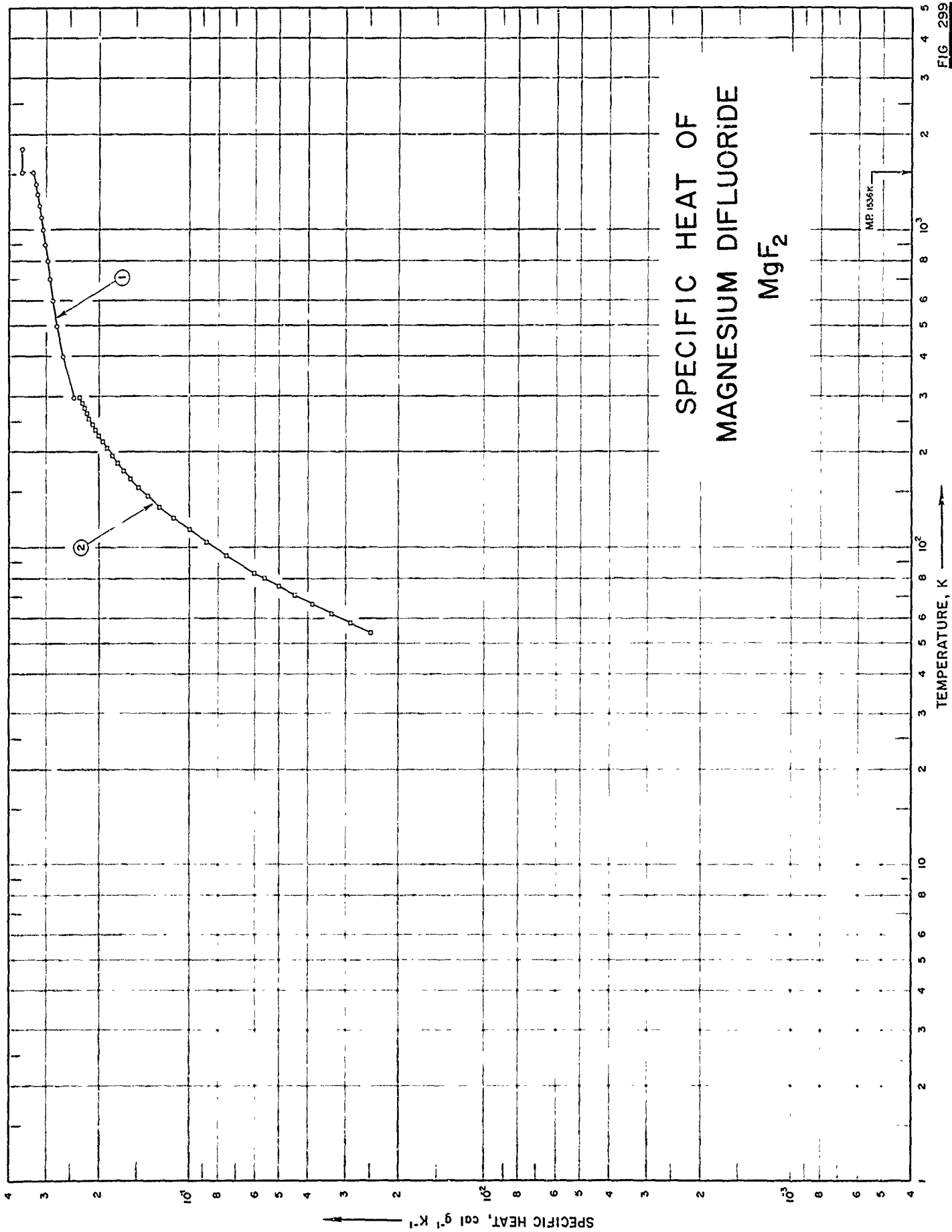

FIG 299

SPECIFICATION TABLE NO. 299 SPECIFIC HEAT OF MAGNESIUM DIFLUORIDE MgF_2

[For Data Reported in Figure and Table No. 299]

Curve No.	Ref. No.	Year	Temp. Range, K	Reported Error, %	Name and Specimen Designation	Composition (weight percent), Specifications and Remarks
1	282	1945	298-800			38.9 Mg; prepared from Baker C. P. MgO; treated with hot 48% HF for 16 hrs and then drying at 400 C.
2	283	1949	54-298	0.3		38.97 Mg (39.02 theo.); purified from Baker, analyzed reagent of 0.5 SO_4 and < 0.3 Ca; treated with hot 48% HF for 16 hrs and dried at 450 C.

DATA TABLE NO. 299 SPECIFIC HEAT OF MAGNESIUM DIFLUORIDE MgF_2 [Temperature, T, K; Specific Heat, Cp, Cal $\text{g}^{-1}\text{K}^{-1}$]

T	Cp		T	Cp	
	CURVE 1	10^{-1}		CURVE 2 (cont.)	10^{-1}
298.5	2.440	10^{-1}	256.20	2.169	10^{-1}
300	2.446*		266.30	2.208	
400	2.658		276.20	2.248	
500	2.777		286.50	2.286	
600	2.861		296.50	2.317*	
700	2.928		298.16	2.325	
800	2.985				
900	3.037				
1000	3.086				
1100	3.132				
1200	3.177				
1300	3.221				
1400	3.265				
1500	3.307*				
(s) 1536	3.323				
(l) 1536	3.622				
1600	3.622*				
1700	3.622*				
1800	3.622				
<u>CURVE 2</u>					
51.22	2.491	10^{-2}			
58.05	2.900				
62.12	3.366				
66.64	3.897				
71.12	4.451				
75.72	5.036				
80.20	5.611				
83.62	6.085				
94.70	7.509				
104.30	8.762				
114.54	1.008	10^{-1}			
124.76	1.132				
135.83	1.265				
146.10	1.375				
155.72	1.475				
166.02	1.572				
176.00	1.660				
186.00	1.741				
196.00	1.815				
206.30	1.886				
216.70	1.954				
226.40	2.012				
236.20	2.063				
246.10	2.113				

* Not shown on plot

FIG. 300

SPECIFIC HEAT OF MANGANESE DIFLUORIDE MnF₂

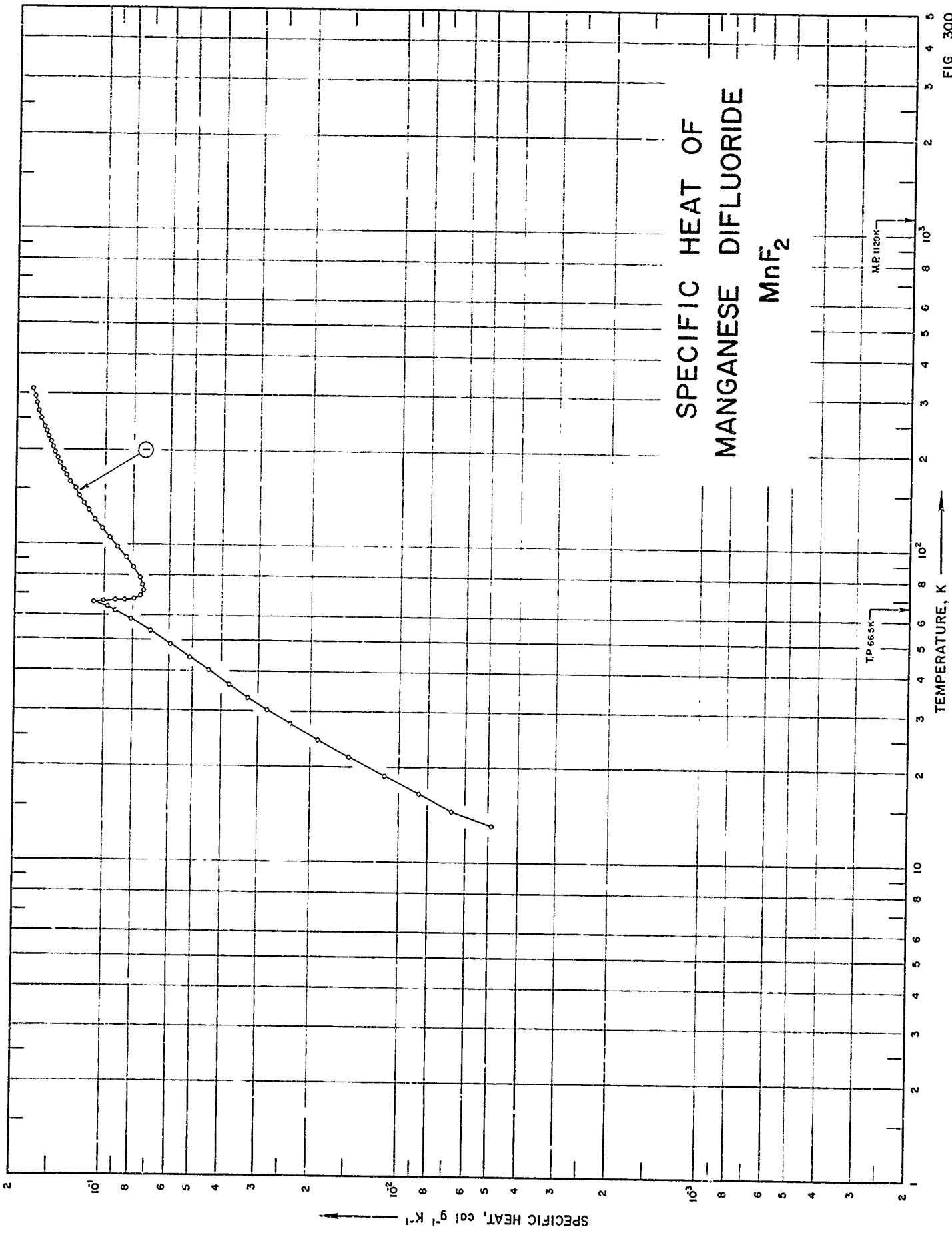

SPECIFICATION TABLE NO. 300 SPECIFIC HEAT OF MANGANESE DIFLUORIDE MnF_2

[For Data Reported in Figure and Table No. 300]

Curve No.	Ref. No.	Year	Temp. Range, K	Reported Error, %	Name and Specimen Designation	Composition (weight percent), Specifications and Remarks
1	291	1942	13-310	0.2-5		58.9 Mn (59.11 theo.); prepared by precipitating $MnCO_3$ from solution of analytical reagent manganous sulfate by means of a solution of sodium carbonate containing sufficient sodium bicarbonate; heated 5 hrs at 250 C to remove volatile impurities.

DATA TABLE NO. 300 SPECIFIC HEAT OF MANGANESE DIFLUORIDE MnF₂[Temperature, T, K; Specific Heat, Cp, Cal g⁻¹K⁻¹]

T	Cp	CURVE I	T	Cp	CURVE I (cont.)	T	Cp	CURVE I (cont.)
Series I								
264.62	1.680 x 10 ⁻¹ *		288.46	1.729 x 10 ⁻¹ *		295.60	1.743	
271.67	1.698*		303.11	1.756*		310.22	1.770	
278.61	1.708*		Series VII					
Series II								
61.94	9.060 x 10 ⁻² *		78.02	7.531 x 10 ⁻² *				
65.53	1.004 x 10 ⁻¹ *							
70.04	7.590*							
74.81	7.427*							
79.40	7.594							
Series III								
13.18	4.928 x 10 ⁻³		80.12	7.630 x 10 ⁻² *				
14.68	6.693		85.60	7.991				
16.60	8.630		91.85	8.463				
18.82	1.130 x 10 ⁻²		98.98	9.025				
21.56	1.489		106.35	9.619				
24.49	1.896		113.78	1.019 x 10 ⁻¹				
27.49	2.348		121.47	1.077				
30.36	2.803		129.06	1.130				
33.16	3.254		136.29	1.177				
36.44	3.781		143.72	1.224				
40.32	4.435		151.23	1.269				
44.33	5.144		158.77	1.313				
48.68	5.973		166.35	1.352				
53.47	6.951		173.67	1.387				
58.51	8.109		181.11	1.419				
62.29	9.168		188.77	1.451				
64.08	9.766		196.56	1.483				
65.23	1.028 x 10 ⁻¹ *		204.57	1.510				
66.05	1.064*		212.28	1.538				
66.55	1.075*		220.14	1.564				
66.99	1.004		Series VI					
67.47	8.504 x 10 ⁻²		221.52	1.570 x 10 ⁻¹ *				
67.98	7.947		228.09	1.587				
68.59	7.741*		235.84	1.613				
69.48	7.571		243.44	1.629*				
70.72	7.453*		250.96	1.652				
72.67	7.398		258.26	1.673*				
75.77	7.452		265.77	1.691				
			273.38	1.700*				
			280.98	1.715				

* Not shown on plot

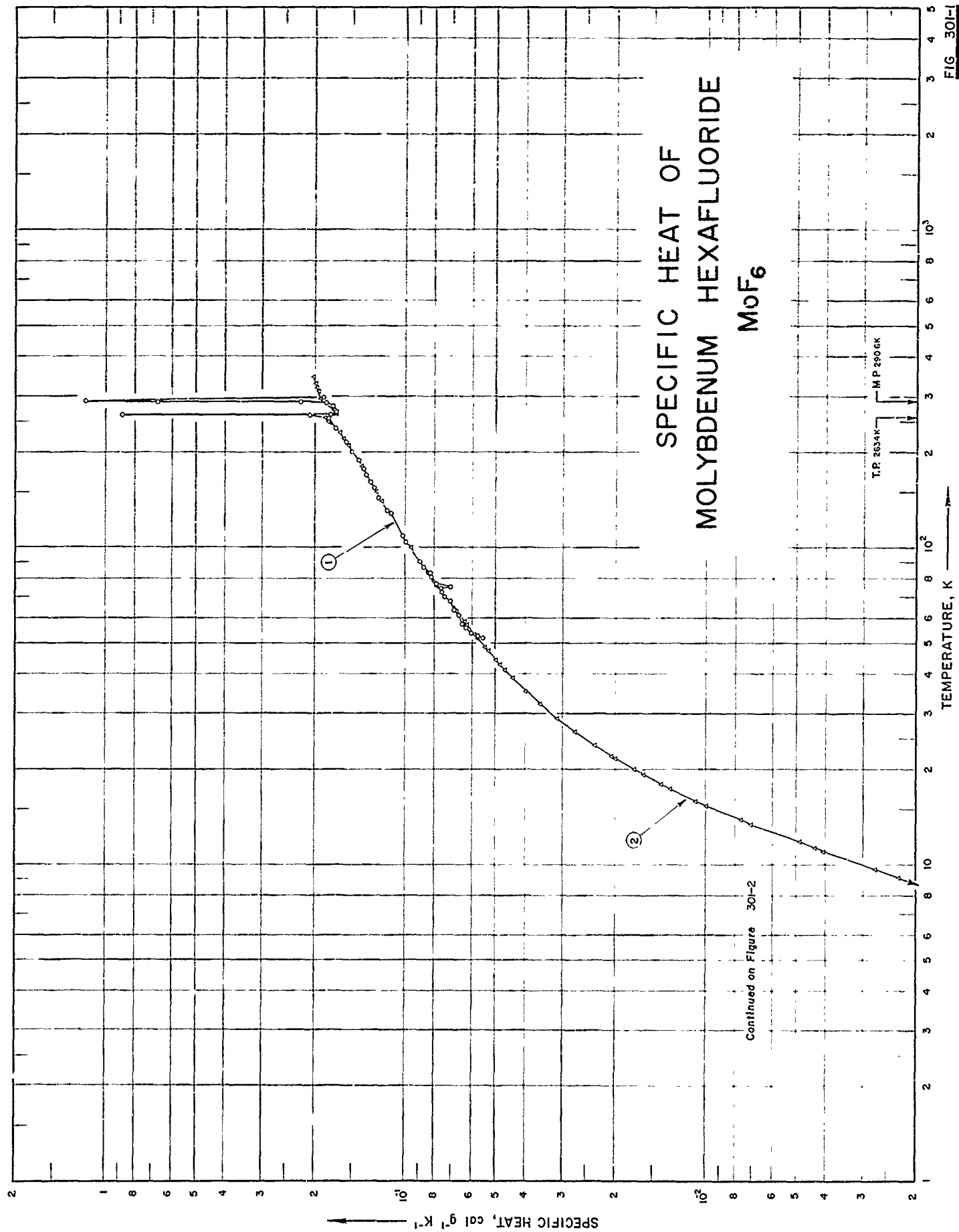
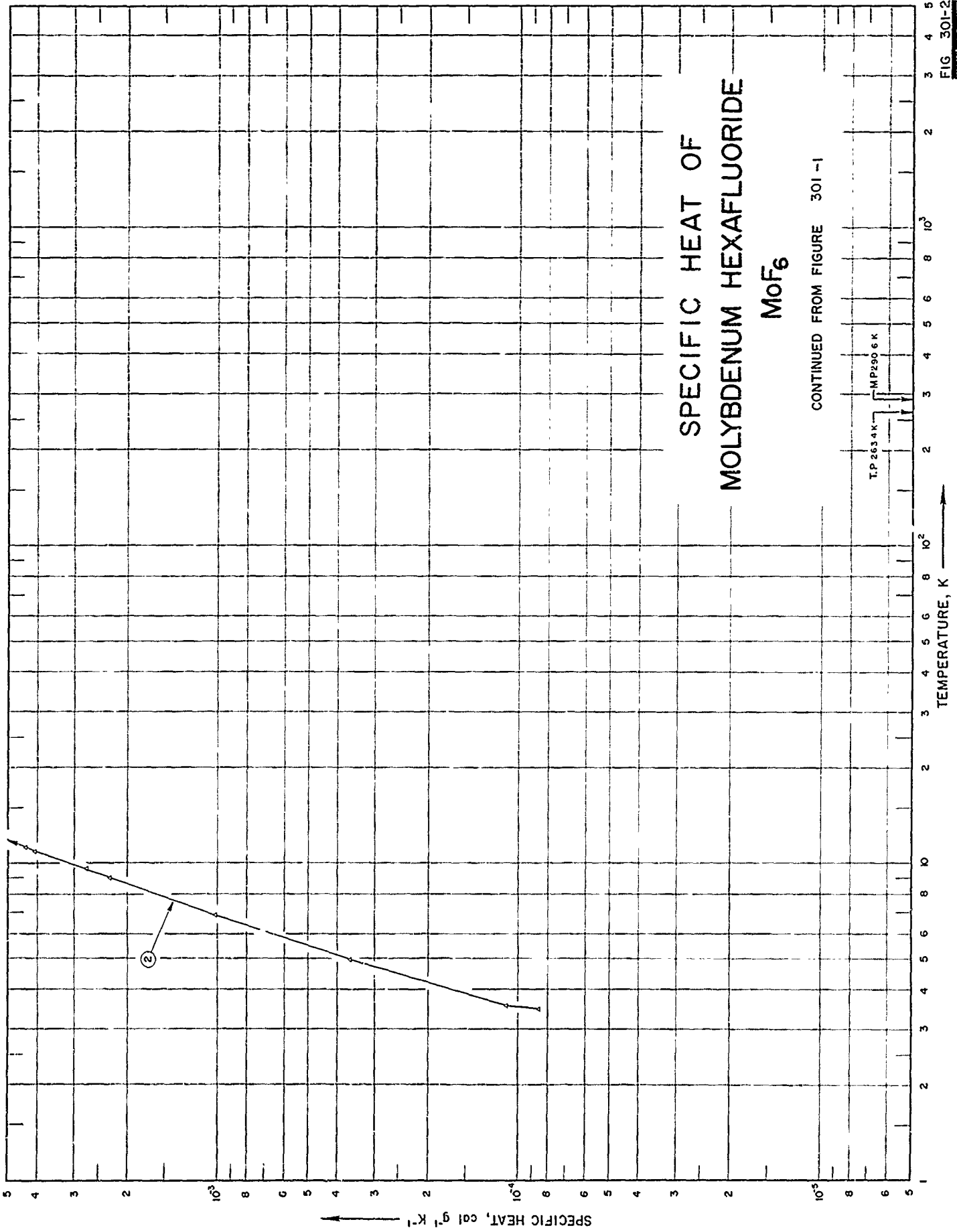

FIG 30I-1



SPECIFICATION TABLE NO. 301 SPECIFIC HEAT OF MOLYBDENUM HEXAFLUORIDE MoF_6

[For Data Reported in Figure and Table No. 301]

Curve No.	Ref. No.	Year	Temp. Range, K	Reported Error, %	Name and Specimen Designation	Composition (weight percent), Specifications and Remarks
1	292	1957	53-298			
2	329	1966	4-347	0.1-5.0		Commercial molybdenum hexafluoride was purified by multiple trap-to-trap distillation. MoF_6 prepared by direct reaction of fluorine at 400 C and molybdenum.

DATA TABLE NO. 301 SPECIFIC HEAT OF MOLYBDENUM HEXAFLUORIDE MoF₆[Temperature, T, K; Specific Heat, Cp, Cal g⁻¹K⁻¹]

T	CURVE 1		CURVE 1 (cont.)		Cp	T	CURVE 2 (cont.)		Cp	T	CURVE 2 (cont.)		Cp
	Cp	T	Cp	T			T	Cp			T	Cp	
52.10	5.578 x 10 ⁻²	239.44	1.711 x 10 ⁻¹	26.69	2.784 x 10 ⁻² *	83.49	8.440 x 10 ⁻² *	Series V	342.59	2.015 x 10 ⁻¹ *	Series X	3.64	1.096 x 10 ⁻⁴
53.09	5.892	240.76	1.728*	29.33	3.170*	91.82	9.050*	Series V	347.52	2.030	Series X	5.12	3.763*
54.10	6.088	243.02	1.737*	32.25	3.572	100.88	9.646	Series V			Series X	7.00	1.038 x 10 ⁻³ *
55.20	6.240*	242.42	1.760*	35.55	3.994	110.70	1.027 x 10 ⁻¹ *	Series V			Series X	8.99	2.210*
56.21	6.345	247.94	1.757*	39.09	4.414	121.11	1.090*	Series V			Series X	11.09	4.082
57.82	6.502	253.80	1.808*	Series II		131.23	1.148*	Series V			Series X	13.37	6.912*
59.77	6.516*	257.57	1.816	41.38	4.671 x 10 ⁻²	141.13	1.202	Series V			Series X	15.40	9.913*
61.74	6.678	259.75	1.891*	44.59	5.016	151.22	1.256	Series V			Series X	17.29	1.296 x 10 ⁻²
63.77	6.936	261.90	1.902*	48.89	5.458	Series VI		Series V			Series X	19.30	1.622
75.87	7.098	261.98	1.898*	53.52	5.907	161.19	1.306 x 10 ⁻¹ *	Series V			Series X	21.40	1.962*
68.06	7.102	262.87	2.094	58.72	6.390	171.18	1.356*	Series V			Series X	23.63	2.313*
70.26	7.407	263.37	8.837	64.30	6.885*	181.29	1.407	Series V			Series X	26.03	2.653*
72.50	7.579	264.95	1.789	Series III		191.36	1.456	Series V			Series X	28.63	3.071*
74.77	7.669	265.08	1.757*	3.55	8.574 x 10 ⁻³	201.39	1.506	Series V			Series X	31.48	3.468*
77.05	7.912	268.55	1.705	5.08	3.620 x 10 ⁻⁴	211.43	1.556	Series V			Series X	34.65	3.883*
78.91	7.950*	270.79	1.711*	6.97	1.015 x 10 ⁻³	221.35	1.605	Series V			Series X		
78.97	8.055*	273.33	1.723*	9.10	2.282	231.22	1.657	Series V			Series XI*		
79.07	8.093*	274.20	1.740*	11.35	4.382	241.22	1.726*	Series V			Series XI*		
80.99	8.203	280.12	1.752	13.49	7.088	251.30	1.817	Series V			Series XI*		
81.12	8.141*	282.25	1.746*	15.45	1.001 x 10 ⁻²	Series VII		Series V			Series XI*		
81.20	8.336*	284.78	1.779*	17.46	1.325	267.22	1.710 x 10 ⁻¹	Series V			Series XI*		
83.92	8.284	286.33	1.791*	21.68	2.007	272.54	1.730	Series V			Series XI*		
87.37	8.722	287.33	1.820*	23.95	2.364	277.88	1.754	Series V			Series XI*		
90.48	8.965	287.75	1.850	26.41	2.742	283.11	1.776	Series V			Series XI*		
92.80	8.898*	288.98	2.242	29.09	3.134	287.77	1.834	Series V			Series XI*		
104.90	9.994	289.02	2.265*	31.99	3.537*	Series IX		Series V			Series XI*		
109.66	1.024 x 10 ⁻¹	289.78	4.848*	Series IV		296.47	1.930 x 10 ⁻¹	Series V			Series XI*		
128.21	1.125	289.91	5.264*	32.72	3.635 x 10 ⁻² *	306.48	1.941*	Series V			Series XI*		
131.71	1.160	289.93	5.481*	35.81	4.020*	311.61	1.966	Series V			Series XI*		
134.72	1.168*	290.09	6.738	39.27	4.433*	316.78	1.975	Series V			Series XI*		
144.27	1.232	290.19	1.173 x 10 ⁰	43.16	4.864	321.96	1.975	Series V			Series XI*		
155.12	1.269	292.92	2.102 x 10 ⁻¹ *	47.62	5.326	327.13	1.986	Series V			Series XI*		
157.55	1.305*	294.46	1.930*	52.41	5.798	332.23	1.994	Series V			Series XI*		
158.56	1.300*	298.09	1.886	57.53	6.280	337.30	2.004	Series V			Series XI*		
160.21	1.298*	Series I		63.26	6.795	342.35	2.014	Series V			Series XI*		
161.46	1.306	9.67	2.734 x 10 ⁻³	69.53	7.330	347.42	2.030	Series V			Series XI*		
170.57	1.356	11.81	4.897	76.61	7.906	Series XII*		Series V			Series XI*		
172.81	1.375*	15.98	7.069	18.03	1.417	238.93	1.708 x 10 ⁻¹	Series V			Series XI*		
175.14	1.370*	18.03	1.417	20.04	1.743	243.93	1.739	Series V			Series XI*		
177.98	1.385	20.04	1.743	22.12	2.078	248.94	1.784	Series V			Series XI*		
180.78	1.386*	22.12	2.078	24.30	2.418*	253.93	1.834	Series V			Series XI*		
189.36	1.438	24.30	2.418*	Series I		258.92	1.875	Series V			Series XI*		
192.09	1.462*	9.67	2.734 x 10 ⁻³	11.81	4.897	267.22	1.710 x 10 ⁻¹	Series V			Series XI*		
192.09	1.462*	11.81	4.897	13.90	7.069	272.54	1.730	Series V			Series XI*		
200.75	1.508	15.98	7.069	15.98	7.069	277.88	1.754	Series V			Series XI*		
200.75	1.508	18.03	1.417	18.03	1.417	283.11	1.776	Series V			Series XI*		
207.53	1.540*	20.04	1.743	20.04	1.743	287.77	1.834	Series V			Series XI*		
216.35	1.589	22.12	2.078	22.12	2.078	Series IX		Series V			Series XI*		
225.24	1.621*	24.30	2.418*	24.30	2.418*	296.47	1.930 x 10 ⁻¹	Series V			Series XI*		
						306.48	1.941*	Series V			Series XI*		
						311.61	1.966	Series V			Series XI*		
						316.78	1.975	Series V			Series XI*		
						321.96	1.975	Series V			Series XI*		
						327.13	1.986	Series V			Series XI*		
						332.23	1.994	Series V			Series XI*		
						337.30	2.004	Series V			Series XI*		
						342.35	2.014	Series V			Series XI*		
						347.42	2.030	Series V			Series XI*		
						238.93	1.708 x 10 ⁻¹	Series IX			Series XII*		
						243.93	1.739	Series IX			Series XII*		
						248.94	1.784	Series IX			Series XII*		
						253.93	1.834	Series IX			Series XII*		
						258.92	1.875	Series IX			Series XII*		

* Not shown on plot

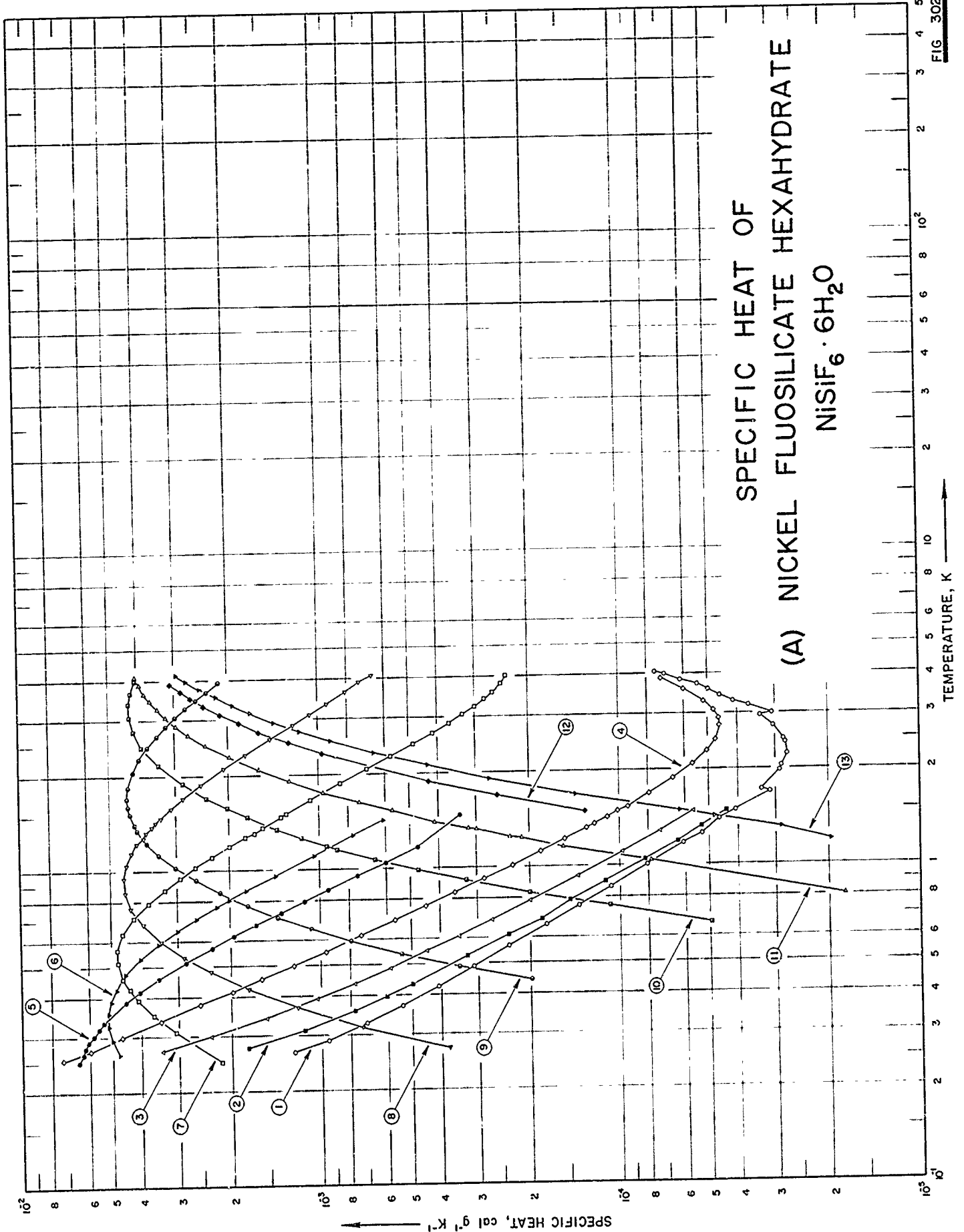

SPECIFICATION TABLE NO. 302 SPECIFIC HEAT OF NICKEL FLUOSILICATE HEXAHYDRATE $\text{NiSi}_6\text{F}_{12}\text{O}_6 \cdot 6\text{H}_2\text{O}$ A

[For Data Reported in Figure and Table No. 302]

Curve No.	Ref. No.	Year	Temp. Range, K	Reported Error, %	Name and Specimen Designation	Composition (weight percent), Specifications and Remarks
1	330	1966	0.26-4.0		H = 0G	High purity sample, $2.4 \pm 0.2 \times 10^{-6}$ Na; spherical single crystal; magnetic field parallel to c-axis.
2	330	1966	0.28-1.5		H = 248G	Same as above.
3	330	1966	0.27-1.5		H = 497G	Same as above.
4	330	1966	0.26-3.9		H = 998G	Same as above.
5	330	1966	0.25-1.5		H = 1987G	Same as above.
6	330	1966	0.27-1.4		H = 2980G	Same as above.
7	330	1966	0.25-4.0		H = 4968G	Same as above.
8	330	1966	0.27-4.1		H = 9935G	Same as above.
9	330	1966	0.44-3.95		H = 19 872G	Same as above.
10	330	1966	0.66-4.0		H = 39 752G	Same as above.
11	330	1966	0.8 -4.15		H = 59 638G	Same as above.
12	330	1966	1.5 -3.9		H = 79 528G	Same as above.
13	330	1966	1.2 -4.2		H = 89 471G	Same as above.

DATA TABLE NO. 302 SPECIFIC HEAT OF NICKEL FLUOSILICATE HEXAHYDRATE, $\text{NiSiF}_6 \cdot 6\text{H}_2\text{O}$ A[Temperature, T, K; Specific Heat, C_p , Cal $\text{g}^{-1} \text{K}^{-1}$]

T	C_p	T	C_p	T	C_p	T	C_p	T	C_p		
<u>CURVE 1</u>											
Series 1											
1.266	5.331×10^{-5}	0.434	4.989×10^{-4}	0.256	7.338×10^{-3}	0.267	4.772×10^{-3}	0.254	2.172×10^{-3}		
1.491	4.113	0.530	3.258	0.274	5.989	0.296	5.035	0.312	3.093		
1.728	3.357	0.615	2.376	0.274	1.843	0.274	5.035	0.353	3.659		
1.988	2.929	0.688	1.843	0.302	1.474	0.326	5.167	0.395	4.113		
2.226	2.764	0.785	1.474	0.338	3.459	0.359	5.167	0.429	4.387		
2.495	2.830	0.899	1.122	0.380	8.260×10^{-5}	0.392	5.068	0.464	3.946		
2.746	3.060	1.050	8.260 $\times 10^{-5}$	0.417	1.991	0.428	4.864	0.520	4.781		
3.175	3.330	1.199	6.384	0.455	1.589	0.476	4.505	0.572	4.498		
3.426	4.607	1.336	5.331	0.501	1.247	0.533	4.011	0.640	4.535		
3.720	5.463	1.485	4.410	0.554	9.675×10^{-4}	0.593	3.498	0.717	4.209		
4.001	7.042	1.485	4.410	0.620	7.371	0.652	3.024	0.777	3.765		
<u>CURVE 2</u>											
Series 2											
0.273	3.422×10^{-3}	0.692	5.663	0.765	4.482	0.841	3.584	0.954	2.945		
0.302	2.353	0.841	3.584	0.929	2.950	1.022	2.287	1.116	2.294		
0.344	1.530	0.929	2.950	1.125	1.849	1.255	1.534	1.204	2.004		
0.393	1.040	1.022	2.287	1.255	1.534	1.431	1.102	1.286	1.774		
0.437	7.799×10^{-4}	1.125	1.849	1.326	1.293	0.962	1.418	1.372	1.570		
0.488	5.937×10^{-4}	1.255	1.534	1.431	1.102	1.116	1.053	1.513	1.300		
0.551	4.466	1.326	1.293	1.545	9.379×10^{-5}	1.284	7.766×10^{-4}				
0.614	3.475	1.431	1.102	1.545	9.379×10^{-5}	1.430	6.131				
0.688	2.695	1.545	9.379×10^{-5}	<u>CURVE 5</u>							
0.789	2.011	1.688	2.011	0.252	6.549×10^{-3}	0.266	6.318	1.284	3.886×10^{-3}		
0.937	1.399	1.787	1.399	0.278	6.220	0.292	6.055	1.380	3.646		
1.111	9.807×10^{-5}	1.886	1.111	0.305	5.825	0.320	5.561	1.486	3.396		
1.286	7.338	1.971	7.338	0.305	5.825	0.359	5.035*	1.597	3.133		
1.471	5.693	2.011	5.693	0.336	5.364	0.389	4.531	1.710	2.866		
<u>CURVE 4</u>											
Series 1											
1.367	1.218×10^{-4}	1.367	1.218 $\times 10^{-4}$	0.421	4.058	0.462	3.495	1.897	2.475		
1.496	1.017	1.496	1.017	0.462	3.495	0.515	2.847	2.121	2.080		
1.698	7.997×10^{-5}	1.698	7.997×10^{-5}	0.515	2.847	0.574	2.333	2.347	1.764		
1.883	6.647	1.883	6.647	0.574	2.333	0.624	1.965	2.618	1.461		
2.085	5.693	2.085	5.693	0.624	1.965	0.675	1.659	2.887	1.221		
2.290	5.068	2.290	5.068	0.675	1.659	0.737	1.362	3.106	1.073		
2.494	4.772	2.494	4.772	0.737	1.362	0.797	1.142	3.352	9.379×10^{-4}		
2.757	4.607	2.757	4.607	0.797	1.142	0.869	9.412×10^{-4}	3.652	8.128		
2.912	4.640	2.912	4.640	0.869	9.412×10^{-4}	0.957	7.536	3.908	7.306		
3.070	4.837	3.070	4.837	0.957	7.536	1.055	6.048	4.138	6.647		
3.291	5.199	3.291	5.199	1.055	6.048	1.176	4.742	Series 2			
3.581	6.055	3.581	6.055	1.176	4.742	1.475	3.409	0.272	3.784×10^{-4}		
3.896	7.207	3.896	7.207	1.475	3.409						
<u>CURVE 2</u>											
Series 2											
0.276	1.777×10^{-3}	0.276	1.777×10^{-3}	0.272	3.784×10^{-4}	0.319	7.371				
0.312	1.152	0.312	1.152	0.319	7.371						
0.359	7.799×10^{-4}	0.359	7.799×10^{-4}							0.442	2.067×10^{-4}
0.396	6.078	0.396	6.078							0.490	3.478
<u>CURVE 7</u>											
Series 2											
0.254	2.172×10^{-3}	0.254	2.172×10^{-3}	0.442	2.067×10^{-4}	0.490	3.478				
0.312	3.093	0.312	3.093	0.540	5.440	0.597	7.997				
0.353	3.659	0.353	3.659	0.655	1.089×10^{-3}	0.712	1.399				
0.395	4.113	0.395	4.113	0.778	1.764	0.855	2.178				
0.429	4.387	0.429	4.387	0.940	2.613	1.035	3.047				
0.504	3.946	0.504	3.946	1.137	3.452	1.237	3.781				
0.604	3.442	0.604	3.442	1.364	4.064						
0.774	4.321	0.774	4.321							Series 2	
0.863	4.498	0.863	4.498							1.269	3.860×10^{-3} *
0.959	4.535	0.959	4.535							1.328	3.985*
1.059	4.446	1.059	4.446							1.423	4.149
1.157	4.265	1.157	4.265							1.527	4.271
1.247	4.041	1.247	4.041							1.622	4.337
1.333	3.807	1.333	3.807							1.718	4.383
1.436	3.528	1.436	3.528							1.867	4.331
<u>CURVE 8</u>											
Series 2 (cont.)											
0.371	1.211×10^{-3}	0.371	1.211×10^{-3}	0.272	3.784×10^{-4}	0.319	7.371				
0.425	1.767	0.425	1.767							0.277	3.975
0.483	2.359	0.483	2.359								
0.539	2.886	0.539	2.886								
0.604	3.442	0.604	3.442								
0.685	3.946	0.685	3.946								
0.774	4.321	0.774	4.321								
0.863	4.498	0.863	4.498								
0.959	4.535	0.959	4.535								
1.059	4.446	1.059	4.446								
1.157	4.265	1.157	4.265								
1.247	4.041	1.247	4.041								
1.333	3.807	1.333	3.807								
1.436	3.528	1.436	3.528								

* Not shown on plot

DATA TABLE NO. 302 (continued)

T	C _p	T	C _p	T	C _p
<u>CURVE 9 (cont.)</u>					
Series 2 (cont.)					
2.481	3.725 x 10 ⁻³	1.329	2.998 x 10 ⁻⁴	1.195	1.974 x 10 ⁻⁵
2.692	3.452	1.429	4.225*	1.422	4.837
2.882	3.225	1.534	5.746	Series 2	
3.073	3.001	1.637	7.371	1.311	2.896 x 10 ⁻⁶
3.286	2.774	1.771	9.708	1.485	6.285
3.483	2.564	1.928	1.260 x 10 ⁻³	1.696	1.408 x 10 ⁻⁴
3.695	2.363	2.095	1.583	1.918	2.708
3.951	2.152	2.300	1.984	2.131	4.341
<u>CURVE 10</u>					
Series 1					
0.660	4.969 x 10 ⁻⁵	2.513	2.386	2.564	9.115
0.751	1.089 x 10 ⁻⁴	2.708	2.718	2.768	1.165 x 10 ⁻³
0.834	2.004	2.897	2.991	2.962	1.418
0.917	3.268	3.089	3.232	3.164	1.682
0.992	4.719	3.233	3.449	3.354	1.925
1.074	6.552	3.475	3.633	3.560	2.188
1.162	8.786	3.676	3.791	3.789	2.475
1.264	1.152 x 10 ⁻³	3.905	3.946	4.022	2.751
1.402	1.537*	4.151	4.071	4.220	2.962
Series 2					
0.501	1.777 x 10 ⁻⁶	Series 2			
1.042	7.898	0.501	1.777 x 10 ⁻⁶	1.777	7.898
1.169	1.557 x 10 ⁻⁴	1.042	7.898	1.169	1.557 x 10 ⁻⁴
1.259	2.336	1.169	1.557 x 10 ⁻⁴	1.259	2.336
1.339	3.182	1.339	3.182	1.339	3.182
1.418	4.160	1.418	4.160	1.418	4.160
<u>CURVE 12</u>					
1.498	1.310 x 10 ⁻⁴	1.498	1.310 x 10 ⁻⁴	1.498	1.310 x 10 ⁻⁴
1.693	2.564	1.693	2.564	1.693	2.564
1.892	4.317	1.892	4.317	1.892	4.317
2.108	6.812*	2.108	6.812*	2.108	6.812*
2.332	9.741	2.332	9.741	2.332	9.741
2.533	1.260 x 10 ⁻³	2.533	1.260 x 10 ⁻³	2.533	1.260 x 10 ⁻³
2.740	1.583	2.740	1.583	2.740	1.583
2.932	1.836	2.932	1.836	2.932	1.836
3.136	2.126	3.136	2.126	3.136	2.126
3.341	2.406	3.341	2.406	3.341	2.406
3.528	2.652	3.528	2.652	3.528	2.652
3.707	2.863	3.707	2.863	3.707	2.863
3.922	3.103	3.922	3.103	3.922	3.103
<u>CURVE 11</u>					
Series 1					
1.244	2.132 x 10 ⁻⁴	Series 1			
1.244	2.132 x 10 ⁻⁴	1.244	2.132 x 10 ⁻⁴	1.244	2.132 x 10 ⁻⁴

* Not shown on plot

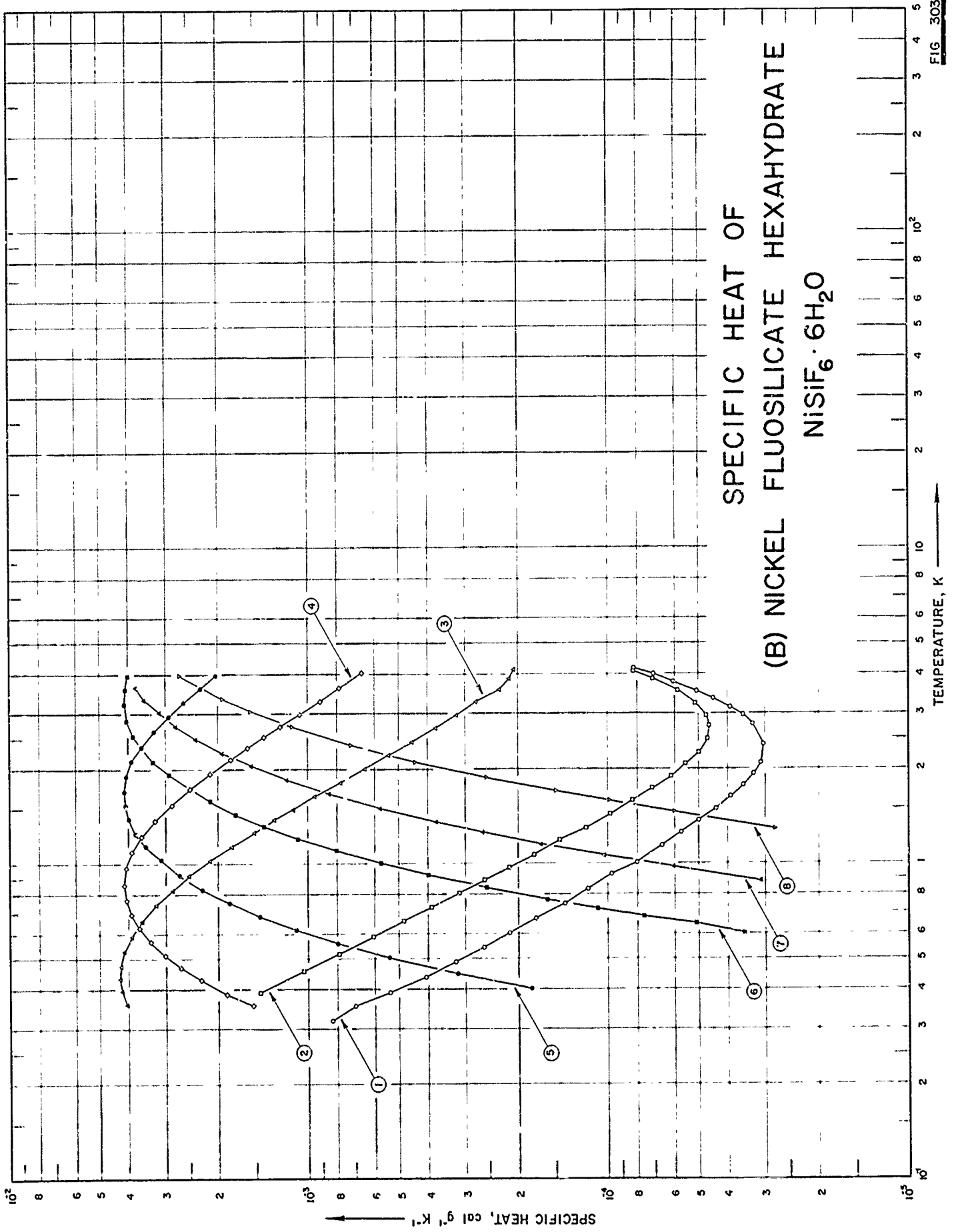

FIG. 303

SPECIFICATION TABLE NO. 303 SPECIFIC HEAT OF NICKEL FLUOSILICATE HEXAHYDRATE $\text{NiSiF}_6 \cdot 6\text{H}_2\text{O}$ B

[For Data Reported in Figure and Table No. 303]

Curve No.	Ref. No.	Year	Temp. Range, K	Reported Error, %	Name and Specimen Designation	Composition (weight percent), Specifications and Remarks
1	331	1967	0.3 -4.2		H = 0G	3.5 cm spherical single crystal, magnetic field perpendicular to the c-axis.
2	331	1967	0.4 -4.0		H = 993G	Same as above.
3	331	1967	0.36-4.1		H = 4968G	Same as above.
4	331	1967	0.35-4.0		H = 9935G	Same as above.
5	331	1967	0.4 -3.9		H = 19 872G	Same as above.
6	331	1967	0.6 -3.9		H = 39 752G	Same as above.
7	331	1967	0.8 -4.0		H = 59 638G	Same as above.
8	331	1967	1.3 -3.9		H = 89 471G	Same as above.

DATA TABLE NO. 303 SPECIFIC HEAT OF NICKEL FLUOSILICATE HEXAHYDRATE NiSiF₆ · 6H₂O B[Temperature, T, K; Specific Heat, C_p, Cal g⁻¹ K⁻¹]

CURVE 1		CURVE 2 (cont.)		CURVE 3		CURVE 4		CURVE 5 (cont.)		CURVE 6		CURVE 7 (cont.)	
T	C _p	T	C _p	T	C _p	T	C _p	T	C _p	T	C _p	T	C _p
0.318	8.376 × 10 ⁻⁴	1.437	9.842 × 10 ⁻⁵	0.355	1.529 × 10 ⁻³	0.364	3.595 × 10 ⁻³	0.601	3.529 × 10 ⁻⁵	0.601	3.529 × 10 ⁻⁵	2.491	2.376 × 10 ⁻³
0.354	7.003	1.579	8.320	0.387	1.878	0.642	3.275	0.645	5.083	0.645	5.083	2.747	2.784
0.392	5.361	1.731	7.123	0.430	2.298	0.731	2.931	0.653	7.576	0.653	7.576	3.025	3.155
0.437	4.089	1.894	6.184	0.471	2.675	0.721	2.601	0.721	1.088 × 10 ⁻⁴	0.721	1.088 × 10 ⁻⁴	3.326	3.535
0.488	3.244	2.068	5.504	0.516	3.028	0.770	2.296	0.770	1.593	0.770	1.593	3.643	3.786
0.544	2.609	2.257	4.986	0.570	3.372	0.800	2.296	0.840	2.548	0.840	2.548	4.001	4.019*
0.604	2.143	2.499	4.662	0.630	3.685	0.923	2.956	0.923	3.956	0.923	3.956		
0.671	1.752	2.732	4.630	0.695	3.685	1.007	5.747	1.007	5.747	1.007	5.747		
0.748	1.428	2.941	4.727	0.770	4.063	1.101	8.026	1.101	8.026	1.101	8.026		
0.832	1.172	3.223	5.148	0.863	4.133	1.208	1.086 × 10 ⁻³	1.208	1.086 × 10 ⁻³	1.208	1.086 × 10 ⁻³		
0.925	9.745 × 10 ⁻⁵	3.540	5.892	0.975	4.078	1.322	1.404	1.322	1.404	1.322	1.404		
1.031	8.029	3.851	7.058	1.097	3.891	1.446	1.753	1.446	1.753	1.446	1.753		
1.144	6.702	4.077	8.256	1.227	3.613	1.587	2.133	1.587	2.133	1.587	2.133		
1.260	5.730			1.375	3.261	1.748	2.534*	1.748	2.534*	1.748	2.534*		
1.374	4.986			1.548	2.869	1.927	2.932	1.927	2.932	1.927	2.932		
1.496	4.371			1.739	2.485	2.119	3.290	2.119	3.290	2.119	3.290		
1.630	3.917			1.946	2.123	2.325	3.591*	2.325	3.591*	2.325	3.591*		
1.770	3.561			2.157	1.817	2.555	3.844	2.555	3.844	2.555	3.844		
1.926	3.270			2.346	1.594	2.851	4.039	2.851	4.039	2.851	4.039		
2.082	3.108			2.532	1.409	3.220	4.124	3.220	4.124	3.220	4.124		
2.384	3.043			2.732	1.240	3.594	4.094	3.594	4.094	3.594	4.094		
2.641	3.140			2.980	1.070	3.962	4.011	3.962	4.011	3.962	4.011		
2.762	3.302			3.271	9.120 × 10 ⁻⁴								
2.955	3.561			3.610	7.890								
3.118	3.917			4.022	6.627								
3.331	4.468												
3.522	5.051												
3.758	6.054												
3.985	7.025												
4.167	8.223												
CURVE 2				CURVE 5				CURVE 7					
0.391	1.459 × 10 ⁻³	0.401	1.800 × 10 ⁻⁴	0.401	1.800 × 10 ⁻⁴	0.401	1.800 × 10 ⁻⁴	0.876	3.108 × 10 ⁻⁵	0.876	3.108 × 10 ⁻⁵	0.876	3.108 × 10 ⁻⁵
0.456	1.042	0.448	3.186	0.448	3.186	0.504	5.397	0.975	6.087	0.975	6.087	0.975	6.087
0.518	7.903 × 10 ⁻⁴	0.559	7.971	0.559	7.971	0.582	1.459	1.064	1.033 × 10 ⁻⁴	1.064	1.033 × 10 ⁻⁴	1.064	1.033 × 10 ⁻⁴
0.586	6.093	0.618	1.107 × 10 ⁻³	0.618	1.107 × 10 ⁻³	0.751	1.841	1.158	1.684	1.158	1.684	1.158	1.684
0.656	4.827	0.682	1.459	0.682	1.459	0.925	2.708	1.259	2.626	1.259	2.626	1.259	2.626
0.728	3.885	0.751	1.841	0.751	1.841	1.028	3.119	1.359	3.768	1.359	3.768	1.359	3.768
0.806	3.137	0.825	2.762	0.825	2.762	1.146	3.498	1.501	5.763	1.501	5.763	1.501	5.763
0.888	2.580	0.891	3.973	0.891	3.973	1.263	3.775	1.53	8.541	1.53	8.541	1.53	8.541
0.974	2.137	0.941	4.094	0.941	4.094	1.391	3.973	1.854	1.179 × 10 ⁻³	1.854	1.179 × 10 ⁻³	1.854	1.179 × 10 ⁻³
1.070	1.771	1.070	4.120	1.070	4.120	1.541	4.120	2.051	1.556	2.051	1.556	2.051	1.556
1.180	1.450	1.906	4.065	1.906	4.065	2.124	3.872	2.253	1.948	2.253	1.948	2.253	1.948
1.304	1.188	2.124	3.872	2.124	3.872								

* Not shown on plot

SPECIFIC HEAT OF NICKEL DIFLUORIDE NiF₂

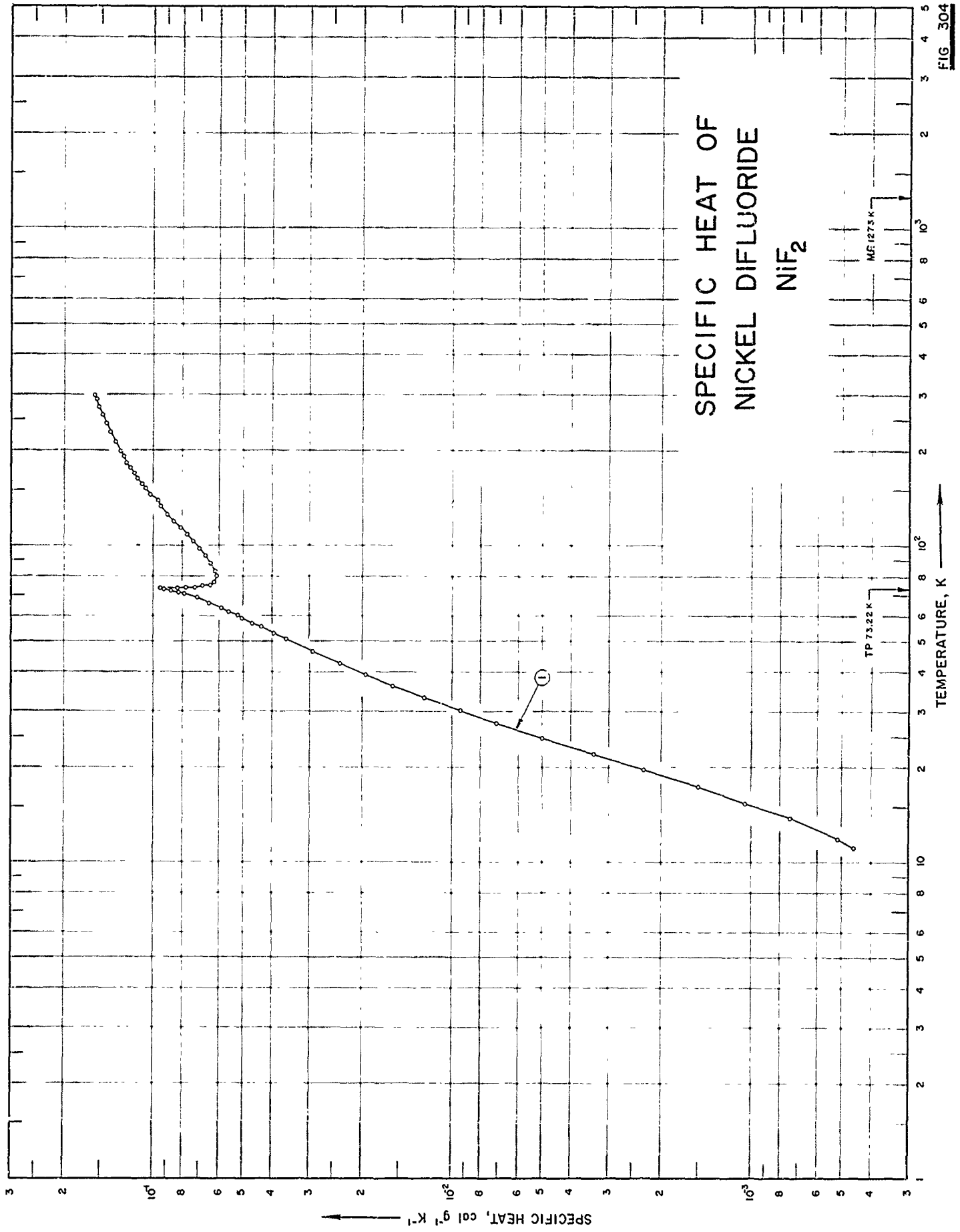

FIG 304

SPECIFICATION TABLE NO. 304 SPECIFIC HEAT OF NICKEL DIFLUORIDE NiF_2

[For Data Reported in Figure and Table No. 304]

Curve No.	Ref. No.	Year	Temp. Range, K	Reported Error, %	Name and Specimen Designation	Composition (weight percent), Specifications and Remarks
1	293	1955	11-298	0.2-3		0.005 Cu, 0.004 Co, 0.003 Fe and 0.001 Mn; single crystals of optically anisotropic material.

DATA TABLE NO. 304 SPECIFIC HEAT OF NICKEL DIFLUORIDE NIF₂
 [Temperature, T, K; Specific Heat, C_p, Cal g⁻¹ K⁻¹]

T	C _p	T	C _p	T	C _p	T	C _p
CURVE 1		CURVE 1 (cont.)		CURVE 1 (cont.)		CURVE 1 (cont.)	
Series 1							
81.52	6.163 x 10 ^{-2*}	266.19	1.503 x 10 ^{-1*}	72.64	9.019 x 10 ^{-2*}	81.25	6.160 x 10 ^{-2*}
84.63	6.265*	274.30	1.527	72.85	9.256*	83.84	6.235*
88.35	6.442	282.40	1.546*	73.00	9.380*	216.10	1.363 x 10 ^{-1*}
Series 2							
53.13	3.966 x 10 ⁻²	290.31	1.565*	73.13	9.494*	233.52	1.388*
57.39	4.699	298.25	1.590*	73.23	9.536	230.55	1.410*
62.27	5.638	Series 4		73.34	9.050*	237.50	1.433*
66.72	6.650*	11.14	4.551 x 10 ⁻⁴	73.45	8.346	299.99	1.582
73.33	7.917*	11.88	5.171	73.69	7.829		
77.68	6.218*	13.76	7.446	73.81	7.229*		
82.32	6.192*	15.42	1.055 x 10 ⁻³	73.93	7.095*		
Series 3							
88.78	6.471 x 10 ^{-2*}	17.40	1.510	74.06	6.981*		
93.09	6.706	19.73	2.296	74.19	6.857*		
98.05	7.025	22.09	3.382	74.32	6.785*		
103.01	7.371	24.74	5.006	74.44	6.743*		
108.30	7.744	27.54	7.105	74.58	6.660*		
114.03	8.144	30.23	9.432	74.71	6.609*		
119.90	8.563	33.21	1.245 x 10 ⁻²	74.84	6.567*		
126.22	8.986	36.25	1.585	74.97	6.516*		
132.78	9.439	39.37	1.960	75.10	6.474*		
139.07	9.673	42.67	2.388	75.23	6.454*		
145.54	1.028 x 10 ⁻¹	46.53	2.944	Series 7			
152.20	1.067	50.85	3.599	71.53	8.295 x 10 ⁻²		
156.92	1.094	59.27	5.061	71.71	8.346*		
163.35	1.128	74.95	6.881	71.90	8.460*		
169.87	1.162	Series 5		72.09	8.615*		
176.70	1.197	55.69	4.389 x 10 ⁻²	72.24	8.770		
183.79	1.231	60.27	5.236	72.35	8.822*		
190.98	1.265	63.73	5.946	72.46	8.884*		
198.08	1.293	66.27	6.531	72.57	8.987*		
205.90	1.325*	68.72	7.189	72.68	9.060*		
213.03	1.346	70.79	7.920	72.79	9.205*		
226.58	1.367*	73.05	9.294	72.89	9.287*		
227.40	1.397	73.84	7.282	72.99	9.380*		
236.39	1.426*	74.51	6.681*	73.10	9.494*		
243.24	1.449	75.16	6.460	73.20	9.546*		
251.28	1.468*	75.88	6.330*	73.30	9.298*		
258.75	1.484	76.94	6.255	73.41	8.481*		
		78.29	6.184*				
		80.10	6.147				
		83.25	6.210				

* Not shown on plot

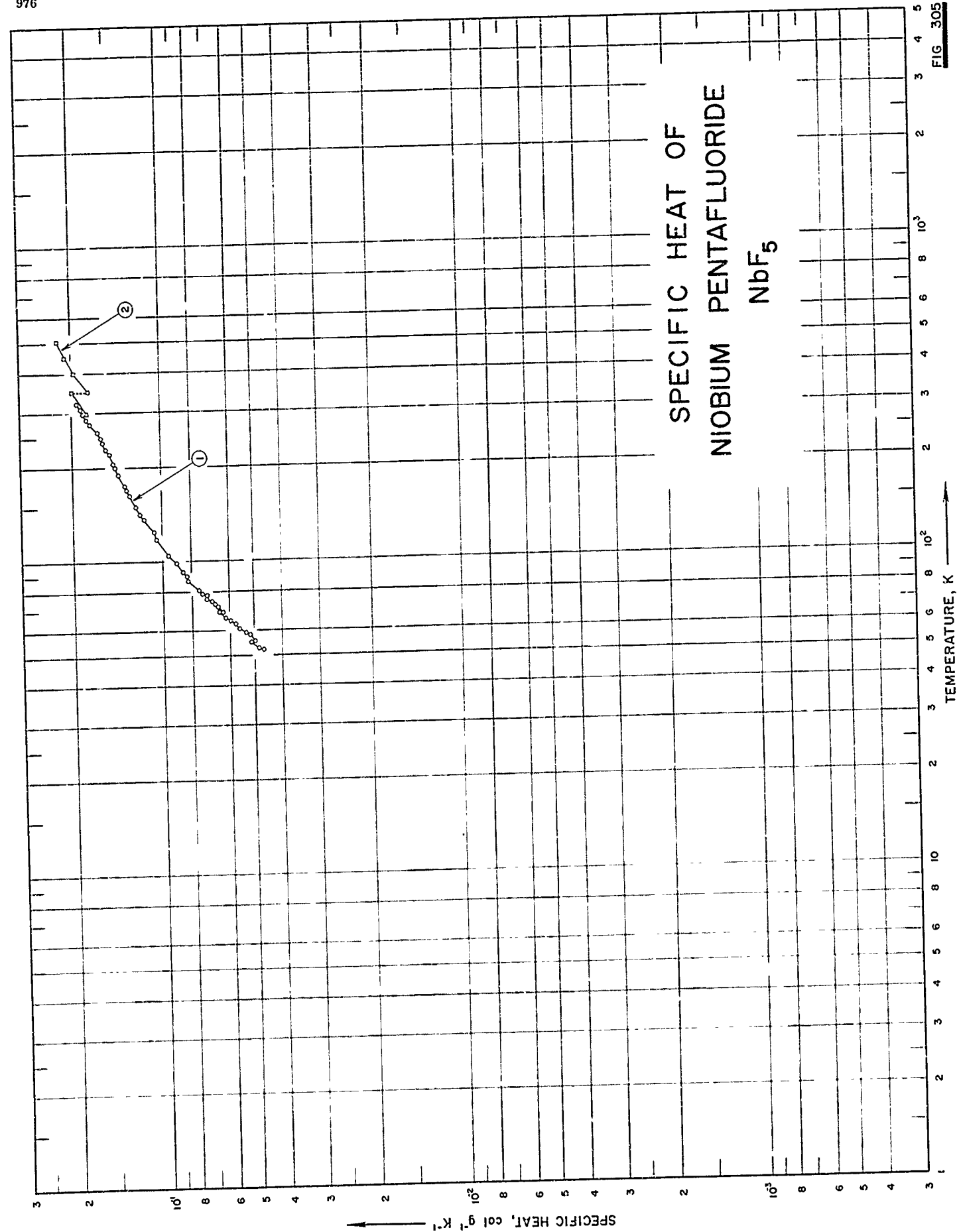

SPECIFICATION TABLE NO. 305 SPECIFIC HEAT OF NIOBIUM PENTAFLUORIDE NbF₅

[For Data Reported in Figure and Table No. 305]

Curve No.	Ref. No.	Year	Temp. Range, K	Reported Error, %	Name and Specimen Designation	Composition (weight percent), Specifications and Remarks
1	332	1957	52-321			0.9 impurity of metallic Nb. (corrected for impurity)
2	322	1957	298-506			Same as above.

DATA TABLE NO. 305 SPECIFIC HEAT OF NIOBIUM PENTAFLUORIDE NbF₅[Temperature, T, K; Specific Heat, C_p, Cal g⁻¹ K⁻¹]

T	C _p	T	C _p
52.40	4.66 x 10 ⁻²	194.39	1.40 x 10 ⁻¹ *
52.80	4.85	200.24	1.43
55.10	5.14	203.41	1.45*
55.39	4.98	206.56	1.45
58.23	5.15	221.52	1.50
58.12	5.34	223.19	1.50*
60.79	5.59	226.15	1.54*
63.01	5.76	229.03	1.55
64.68	5.99	237.22	1.57*
66.10	6.24	240.85	1.58
66.66	6.20*	249.21	1.59
68.94	6.55	255.53	1.62*
68.95	6.36	258.25	1.63*
71.57	6.62	260.86	1.63
73.08	6.75	274.20	1.69*
73.23	6.89*	274.57	1.73*
74.51	6.90	277.64	1.74
75.87	7.18	287.48	1.78
78.10	7.16	291.35	1.81*
78.60	7.36*	293.98	1.80*
78.76	7.43	298.60	1.82
81.21	7.60	304.97	1.85*
82.09	7.58*	308.02	1.86
86.79	8.20	311.07	1.87*
89.03	8.35	313.50	1.87*
92.56	8.56	320.72	1.92
98.92	9.05		
105.01	9.57		
107.04	9.64*		
117.78	1.05 x 10 ⁻¹		
120.04	1.05*	298.2	1.775 x 10 ⁻¹
125.79	1.06	350.7	1.984
137.01	1.16	350.7	1.754
139.39	1.16*	400.0	1.956
142.14	1.19	450.0	2.097
145.01	1.19*	506.5	2.209
147.50	1.21*		
149.92	1.22		
152.91	1.24*		
163.40	1.28		
165.93	1.29*		
170.52	1.31		
175.53	1.34		
187.71	1.38*		
189.74	1.40		

* Not shown on plot

SPECIFIC HEAT OF POTASSIUM FLUORIDE KF

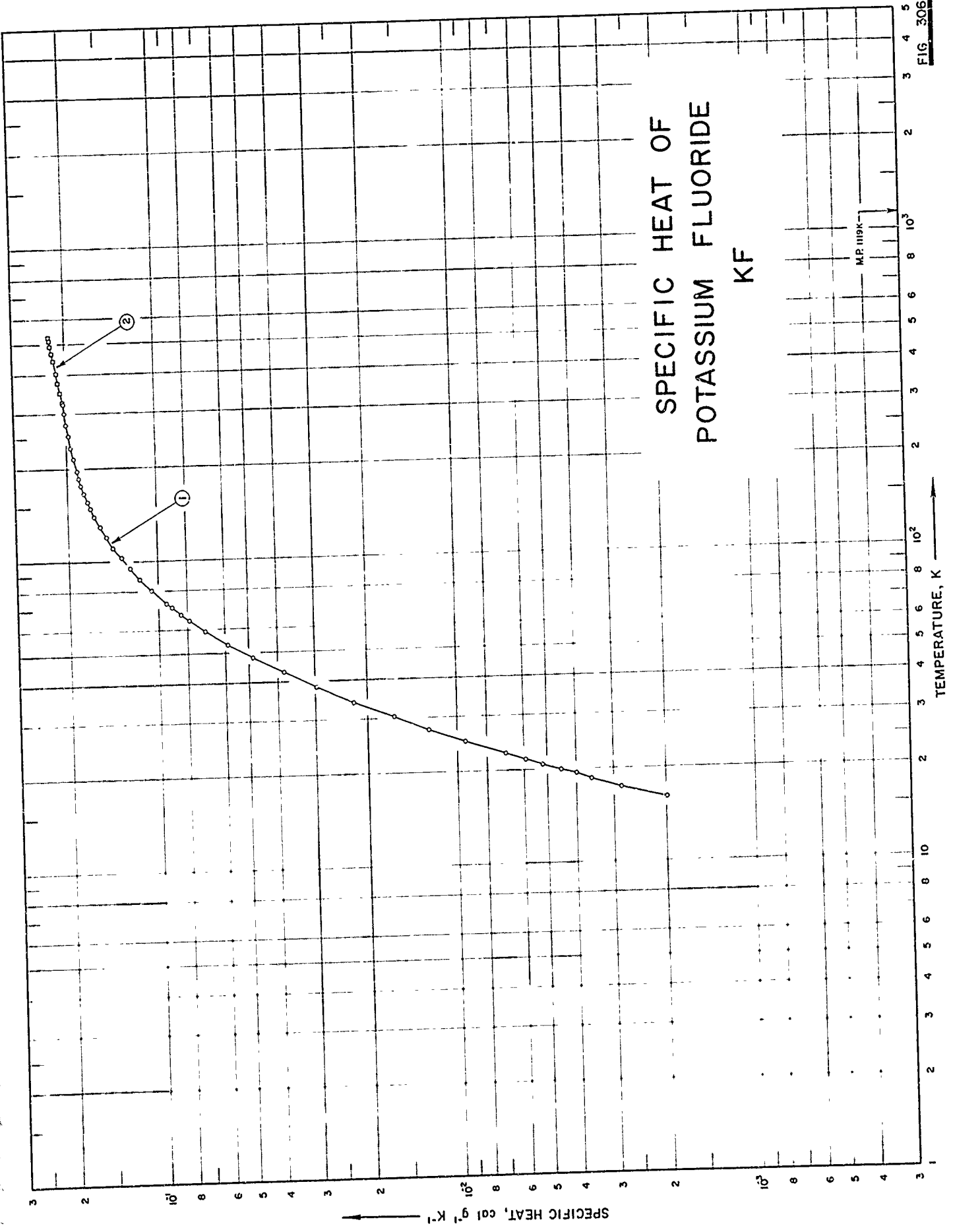

SPECIFICATION TABLE NO. 306 SPECIFIC HEAT OF POTASSIUM FLUORIDE KF

[For Data Reported in Figure and Table No. 306]

Curve No.	Ref. No.	Year	Temp. Range, K	Reported Error, %	Name and Specimen Designation	Composition (weight percent), Specifications and Remarks
1	333	1949	16-323	0.2-1.0		
2	333	1949	325-530	0.2-1.0		

DATA TABLE NO. 306 SPECIFIC HEAT OF POTASSIUM FLUORIDE KF

[Temperature, T, K; Specific Heat, C_p, Cal g⁻¹ K⁻¹]

T	C _p	T	C _p
	<u>CURVE 1</u>		<u>CURVE 1 (cont.)</u>
16.05	1.992 x 10 ⁻³	300.35	2.014 x 10 ⁻¹
17.46	2.835	311.35	2.029*
18.55	3.556	322.63	2.035
19.43	3.995		
19.95	4.491		
20.70	5.195		
21.57	5.906		
22.63	6.877		
24.91	9.402		
27.42	1.254 x 10 ⁻²		
30.33	1.628		
33.97	2.233		
38.37	2.969		
43.08	3.820		
48.28	4.845		
53.43	5.890		
58.99	6.999		
58.50	6.932*		
64.22	7.927		
67.04	8.422		
70.51	9.006		
73.31	9.436		
80.57	1.057 x 10 ⁻¹		
87.81	1.156		
95.06	1.244		
102.76	1.326		
111.41	1.412		
120.39	1.486		
129.84	1.557		
140.10	1.625		
148.20	1.671		
157.41	1.710		
167.19	1.751		
176.98	1.790		
186.40	1.819		
196.10	1.849		
206.05	1.874*		
215.18	1.899		
223.28	1.911*		
233.33	1.936		
244.33	1.950*		
255.45	1.967		
266.69	1.983*		
277.66	1.998		
288.86	2.007*		

* Not shown on plot

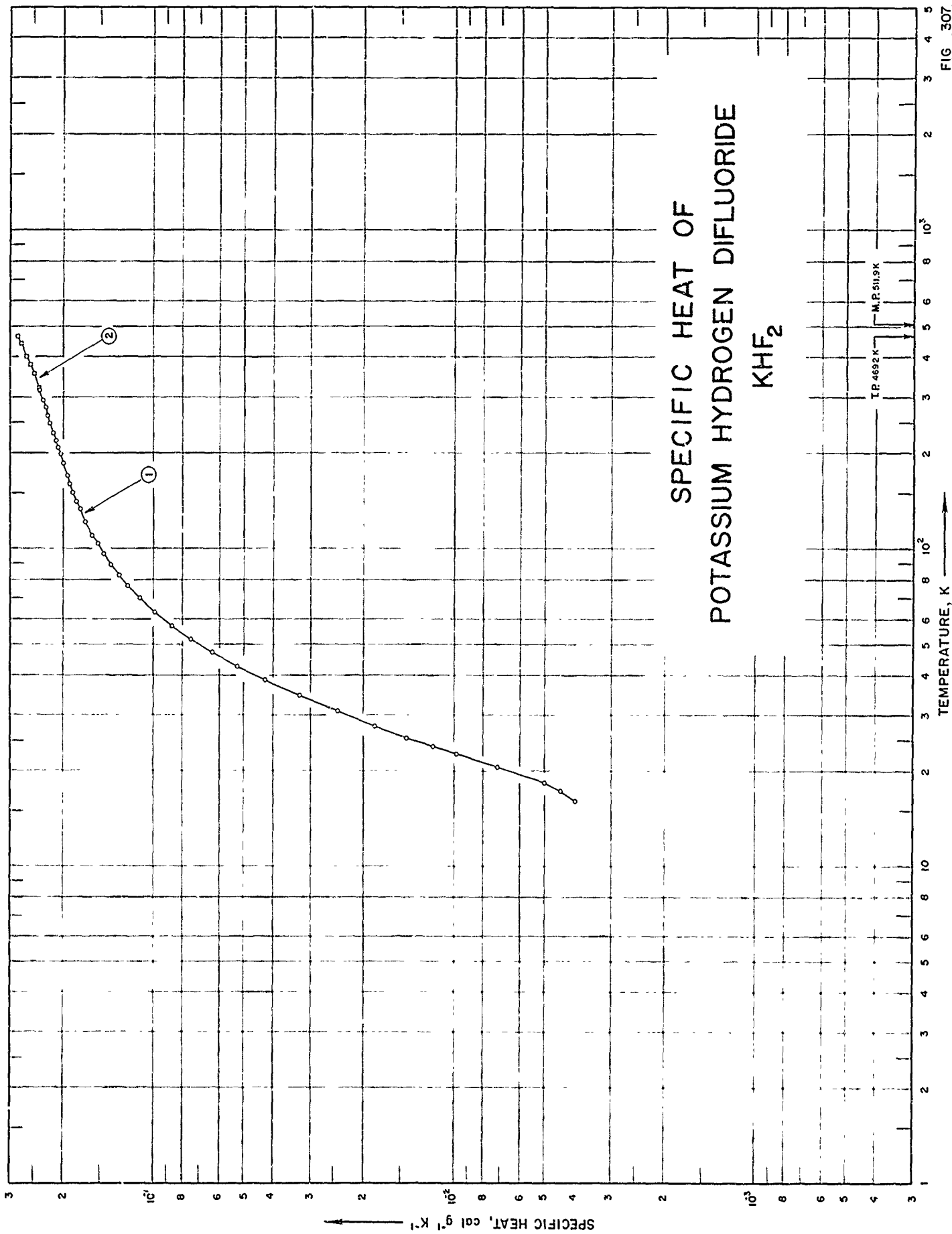

FIG. 307

SPECIFICATION TABLE NO. 307 SPECIFIC HEAT OF POTASSIUM HYDROGEN DIFLUORIDE KHF₂

[For Data Reported in Figure and Table No. 307]

Curve No.	Ref. No.	Year	Temp. Range, K	Reported Error, %	Name and Specimen Designation	Composition (weight percent), Specifications and Remarks
1	333	1949	16-316	0.2		0.02 Na and 0.001 H ₂ SiF ₆ .
2	333	1949	322-465	0.2		Same as above.

DATA TABLE NO. 307 SPECIFIC HEAT OF POTASSIUM HYDROGEN DIFLUORIDE KHF_2 [Temperature, T, K; Specific Heat, C_p , Cal $\text{g}^{-1} \text{K}^{-1}$]

T	C_p	CURVE 1 (cont.)	
		T	C_p
16.02	3.956×10^{-3}	179.28	1.977×10^{-1} *
17.34	4.417	180.58	1.970*
18.45	4.993	186.89	2.002
20.55	7.196	189.03	2.015*
22.64	9.846	196.34	2.038*
23.90	1.175×10^{-2}	198.44	2.045
25.49	1.435	206.19	2.074*
27.73	1.836	208.52	2.078
30.95	2.425	216.25	2.110*
34.71	3.267	219.17	2.120
38.71	4.269	221.57	2.124*
42.73	5.260	229.65	2.147*
47.28	6.351	232.30	2.164
52.03	7.518	239.39	2.179*
57.42	8.703	242.91	2.192
63.12	9.918	248.89	2.214
63.33	9.898*	254.28	2.228*
70.17	1.111	258.25	2.238*
71.85	1.137*	263.38	2.257
76.83	1.223×10^{-1}	268.56	2.267*
78.03	1.235*	274.89	2.288*
78.99	1.248*	279.83	2.285
83.17	1.307	284.18	2.319*
85.67	1.341*	294.33	2.340
89.44	1.384	304.09	2.379*
96.58	1.461	315.79	2.402
99.32	1.488*		
104.10	1.536		
106.90	1.561*		
111.62	1.600		
113.91	1.617*		
115.16	1.630*		
122.63	1.682		
124.21	1.695*		
131.71	1.744*		
133.18	1.755		
140.73	1.801*		
142.10	1.808		
149.73	1.846*		
151.82	1.855		
158.84	1.890*		
161.48	1.900		
168.08	1.929*		
170.46	1.938		
177.38	1.965*		

CURVE 2	
T	C_p
321.6	2.406×10^{-1}
356.4	2.508
380.8	2.581
404.3	2.650
443.7	2.767
463.7	2.826*
465.3	2.831

* Not shown on plot

FIG 308

SPECIFIC HEAT OF RUBIDIUM FLUORIDE RbF

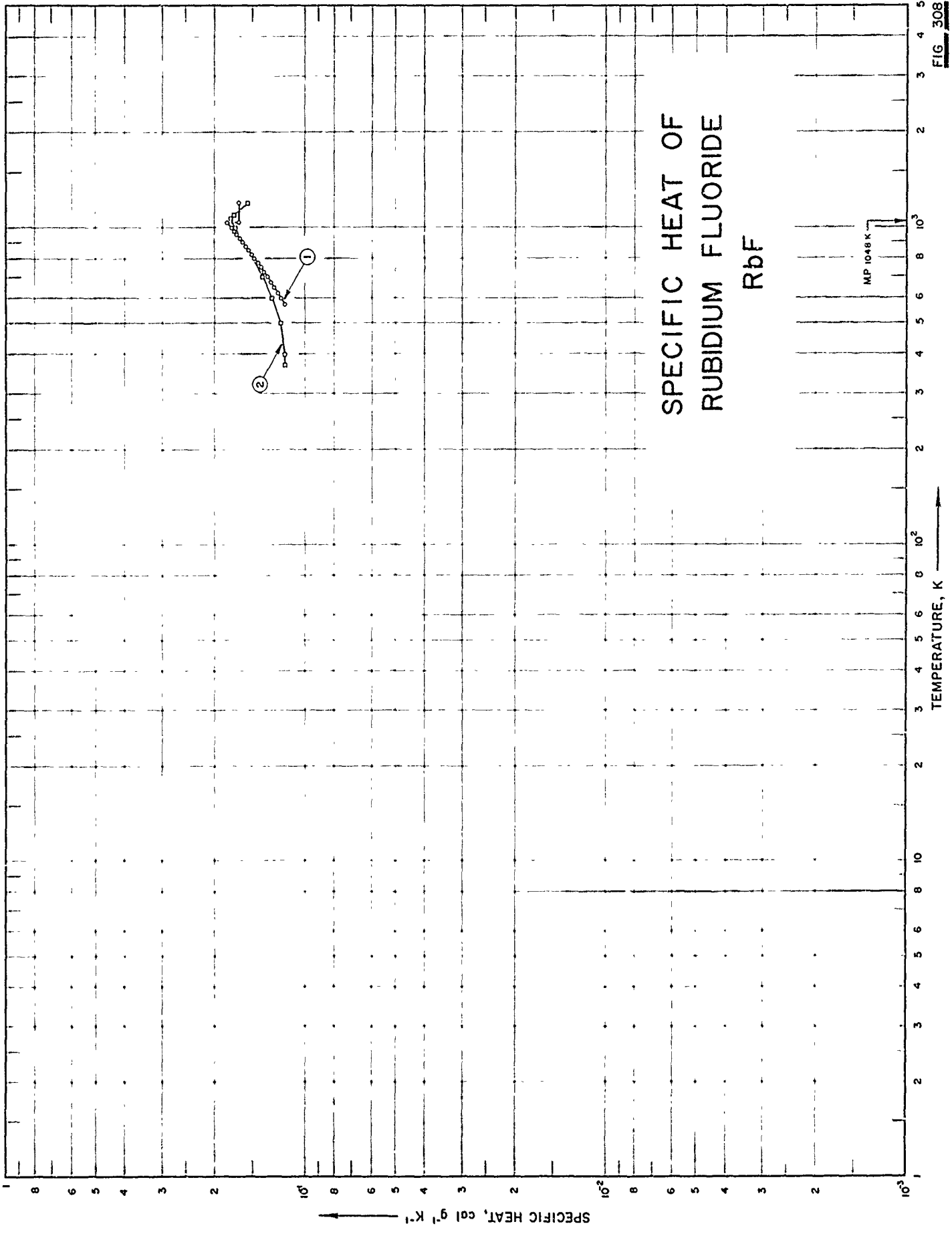

SPECIFIC HEAT, cal g⁻¹ K⁻¹

TEMPERATURE, K

SPECIFICATION TABLE NO. 308 SPECIFIC HEAT OF RUBIDIUM FLUORIDE RbF

[For Data Reported in Figure and Table No. 308]

Curve No.	Ref. No.	Year	Temp. Range, K	Reported Error, %	Name and Specimen Designation	Composition (weight percent), Specifications and Remarks
1	251	1958	575-1200			0.2 KF and a trace of NaF.
2	252	1961	370-1200			99.8 RbF.

DATA TABLE 101. 308 SPECIFIC HEAT OF RUBIDIUM FLUORIDE RbF
 [Temperature, T, K; Specific Heat, C_p , Cal g⁻¹ K⁻¹]

T	C_p	
	CURVE 1	CURVE 2 (cont.)
	1.174 x 10 ⁻¹	
575	1.206	Liquid
600	1.240	1.773 x 10 ⁻¹
625	1.273	1.731
650	1.307	1.564
675	1.342	
700	1.376	
725	1.411	
750	1.446	
775	1.481	
800	1.516	
825	1.552	
850	1.587	
875	1.623	
900	1.659	
925	1.694	
950	1.730	
975	1.766	
1000	1.802*	
1025	1.836	
(s) 1048	1.669	
(l) 1048	1.669*	
1050	1.669*	
1075	1.669*	
1100	1.669*	
1125	1.669*	
1150	1.669*	
1175	1.669*	
1200	1.669	
	CURVE 2	
	Solid	
	1.174 x 10 ⁻¹	
370	1.173	
400	1.215	
500	1.295	
600	1.391	
700	1.497*	
800	1.607*	
900	1.722	
1000	1.763*	
1035		

* Not shown on plot

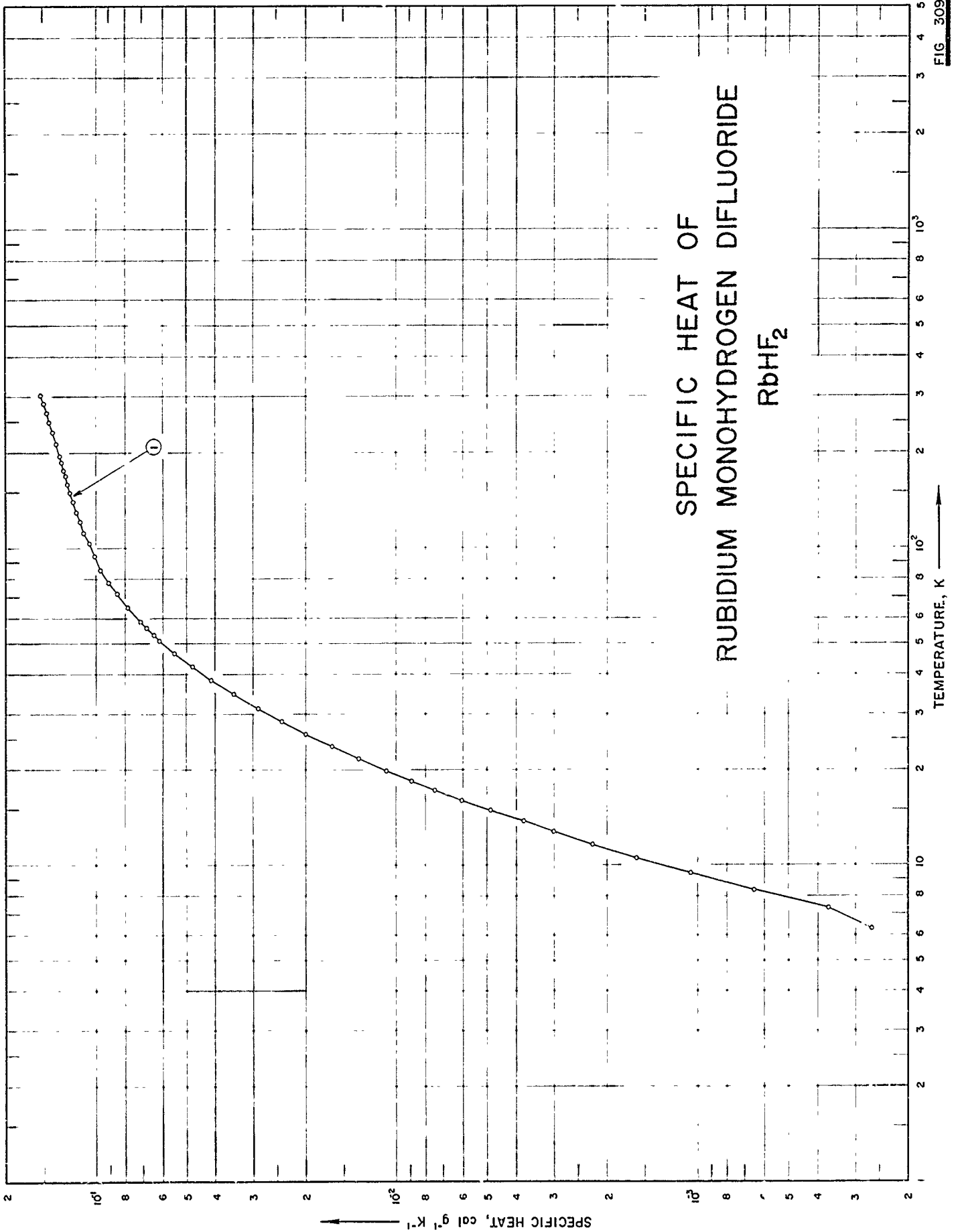

FIG. 309

SPECIFICATION TABLE NO. 309 SPECIFIC HEAT OF RUBIDIUM MONOHYDROGEN DIFLUORIDE RbHF_2

[For Data Reported in Figure and Table No. 309]

Curve No.	Ref. No.	Year	Temp. Range, K	Reported Error, %	Name and Specimen Designation	Composition (weight percent), Specifications and Remarks
1	286	1961	5-303			Fluoride 99.97 \pm 0.15% of theoretical.

DATA TABLE NO. 309 SPECIFIC HEAT OF RUBIDIUM MONOHYDROGEN DIFLUORIDE RbHF₂[Temperature, T, K; Specific Heat, C_p, Cal g⁻¹ K⁻¹]

T	C _p	T	C _p
<u>CURVE 1</u>		<u>CURVE 1 (cont.)</u>	
Series 1			
53.29	6.425 x 10 ⁻²	15.99	6.065 x 10 ⁻³
58.52	7.123	17.22	7.462
65.29	7.890	18.43	8.916
71.70	8.507	19.86	1.084 x 10 ⁻²
78.39	9.085	21.64	1.334
85.99	9.655	23.70	1.647
94.42	1.016 x 10 ⁻¹	25.95	2.005
103.38	1.062	28.44	2.417
112.37	1.100	31.29	2.909
121.54	1.137	34.64	3.493
130.93	1.170	38.41	4.146
140.40	1.198	42.34	4.794
149.82	1.225	46.61	5.471
159.10	1.248	51.37	6.176
168.20	1.270	56.40	6.844
177.15	1.289		
186.07	1.308		
195.05	1.326		
204.02	1.344*		
213.02	1.362		
222.11	1.378*		
231.24	1.395		
240.21	1.414*		
249.12	1.432		
258.04	1.446*		
267.02	1.463		
276.08	1.480		
285.14	1.497		
294.21	1.516*		
303.24	1.534		
Series 2			
5.34	1.607 x 10 ⁻⁴		
6.34	2.651		
7.31	3.695		
8.31	6.507		
9.41	1.068 x 10 ⁻³		
10.50	1.607		
11.67	2.241		
12.76	3.004		
13.76	3.800		
14.87	4.900		

* Not shown on plot

FIG. 310

SPECIFIC HEAT OF SILICON TETRAFLUORIDE SiF₄

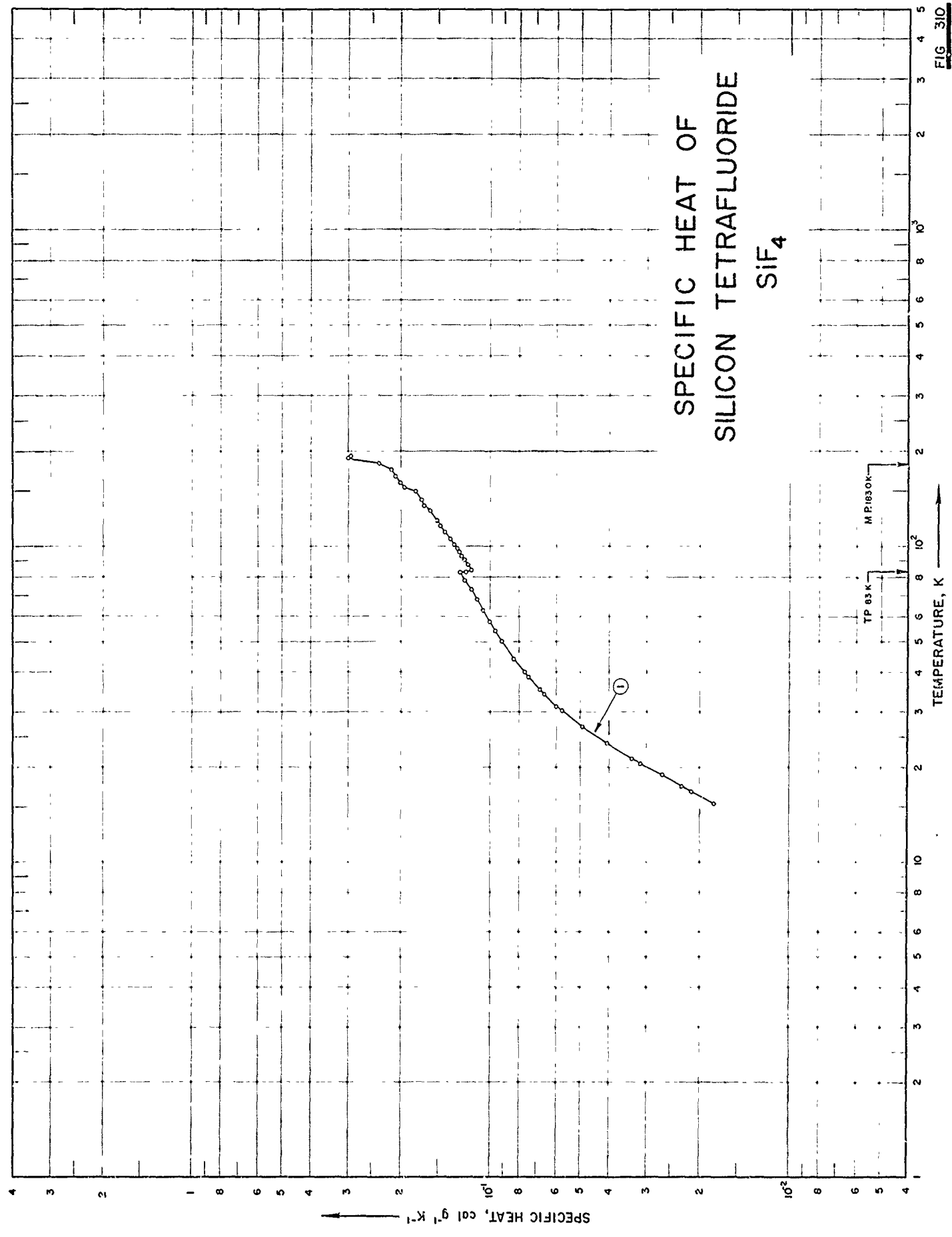

TEMPERATURE, K

SPECIFICATION TABLE NO. 310 SPECIFIC HEAT OF SILICON TETRAFLUORIDE SiF_4

[For Data Reported in Figure and Table No. 310]

Curve No.	Re. No.	Year	Temp. Range, K	Reported Error, %	Name and Specimen Designation	Composition (weight percent), Specifications and Remarks
1	295	1963	15-194	~2		99.97 SiF_4 .

DATA TABLE NO. 310 SPECIFIC HEAT OF SILICON TETRAFLUORIDE SiF_4 [Temperature, T, K; Specific Heat, C_p , Cal $\text{g}^{-1} \text{K}^{-1}$]

T	C_p		T	C_p	
	CURVE 1	10^{-2}		CURVE 1 (cont.)	10^{-1} *
15.34	1.772	10^{-2}	103.75	1.334	10^{-1} *
16.75	2.090		106.35	1.359	
17.49	2.261		108.90	1.384*	
18.80	2.633		111.45	1.412	
20.61	3.137		114.10	1.437*	
21.31	3.326		116.60	1.460	
23.77	4.015		119.14	1.484*	
24.02	4.101*		121.59	1.504	
26.93	4.872		124.22	1.529*	
27.27	5.001*		126.62	1.551*	
30.42	5.743		129.34	1.578*	
31.14	5.955		131.72	1.600*	
34.07	6.551		132.42	1.611*	
35.20	6.792		133.46	1.609*	
38.62	7.419		134.52	1.626*	
40.00	7.627		136.20	1.652	
44.14	8.282		136.87	1.661*	
45.65	8.473*		138.59	1.661*	
50.09	9.071		141.21	1.697	
54.02	9.580		143.95	1.717*	
56.05	9.762*		146.46	1.744*	
57.67	9.992		149.35	1.772	
59.22	1.011×10^{-1} *		151.75	1.798*	
62.90	1.056		154.61	1.840	
64.32	1.068*		156.91	1.971*	
68.02	1.108		159.75	1.993	
69.35	1.128*		164.76	2.040*	
73.10	1.156		167.35	2.070	
74.64	1.171*		169.8*	2.092*	
78.14	1.217		171.14	2.096*	
79.90	1.233*		172.43	2.131*	
83.87	1.242*		174.88	2.135*	
83.17	1.258		175.24	2.143	
83.25	1.260		177.39	2.165*	
84.84	1.159*		179.94	2.200*	
85.82	1.170*		180.67	2.205*	
87.94	1.188		180.89	2.272*	
88.21	1.196*		182.25	2.355	
89.79	1.207*		190.07	2.384	
90.79	1.214		191.91	2.946*	
92.74	1.234*		192.44	2.965*	
92.43	1.241		193.88	2.929	
96.03	1.266				
98.66	1.288				
101.29	1.311				

* Not shown on plot

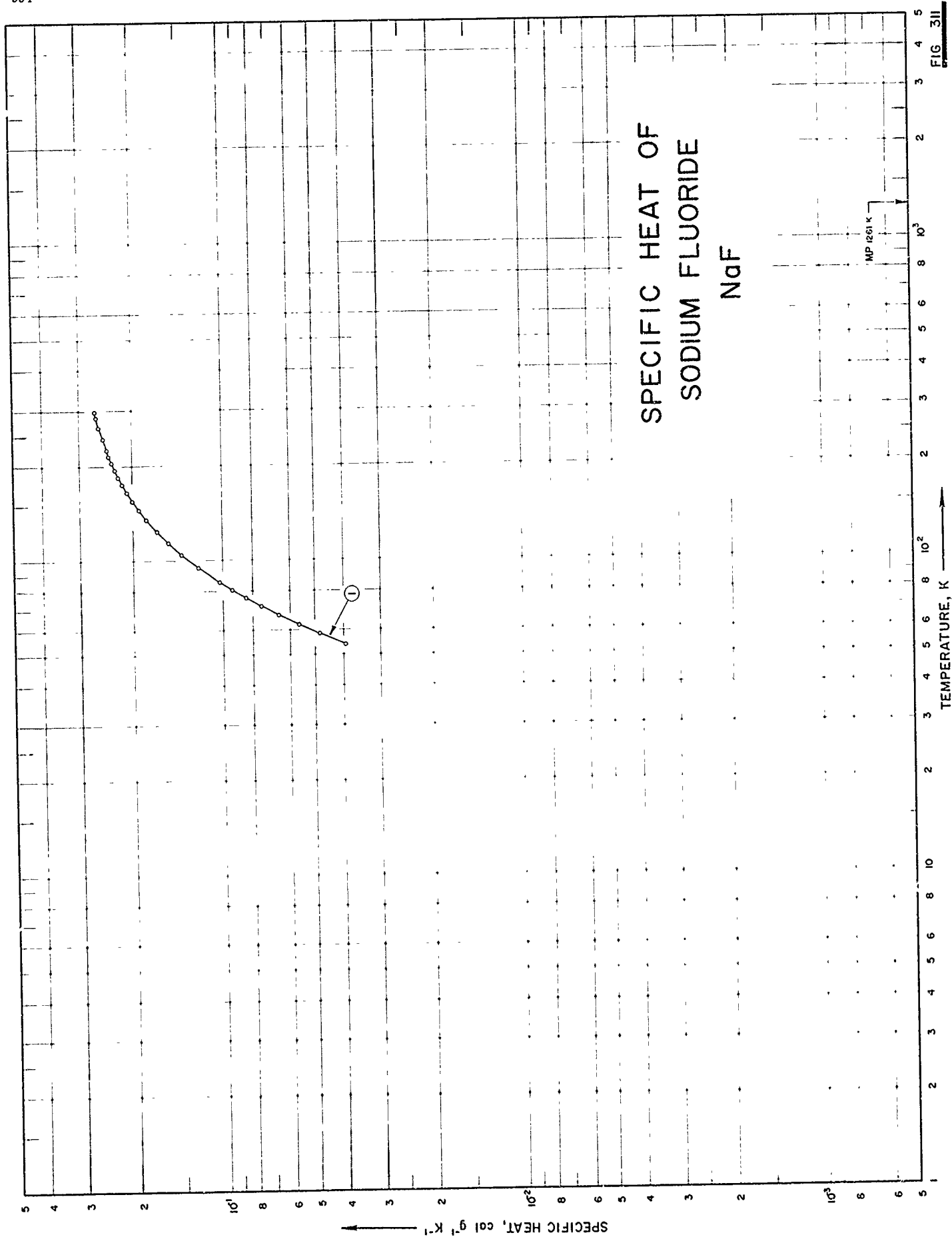

FIG. 311

SPECIFICATION TABLE NO. 311 SPECIFIC HEAT OF SODIUM FLUORIDE NaF

[For Data Reported in Figure and Table No. 311]

Curve No.	Ref. No.	Year	Temp. Range, K	Reported Error, %	Name and Specimen Designation	Composition (weight percent), Specifications and Remarks
1	279	1956	54-298			Analytical reagent powder; sample supplied by the Mallinckrodt Chem. Co; heated at 700 C immediately before specific heat measurements.

DATA TABLE NO. 311 SPECIFIC HEAT OF SODIUM FLUORIDE NaF

[Temperature, T, K; Specific Heat, C_p , Cal $g^{-1} K^{-1}$]

T	C_p
CURVE 1	
54.01	3.951×10^{-2}
58.57	4.822
62.80	5.668
67.29	6.597
71.81	7.537
76.33	8.466
80.98	9.419
85.79	1.037×10^{-1}
95.40	1.217
105.04	1.383
114.61	1.532
124.46	1.669
135.98	1.811
145.74	1.919
155.77	2.015
165.84	2.099
175.84	2.173
186.05	2.242
195.79	2.298
205.89	2.353
216.14	2.401
225.80	2.446
235.96	2.486*
245.66	2.517
255.40	2.555*
266.20	2.598
276.20	2.612*
287.15	2.641
295.86	2.660*
298.95	2.665

* Not shown on plot

FIG. 312

SPECIFIC HEAT OF TRISODIUM ALUMINUM HEXAFLUORIDE Na_3AlF_6

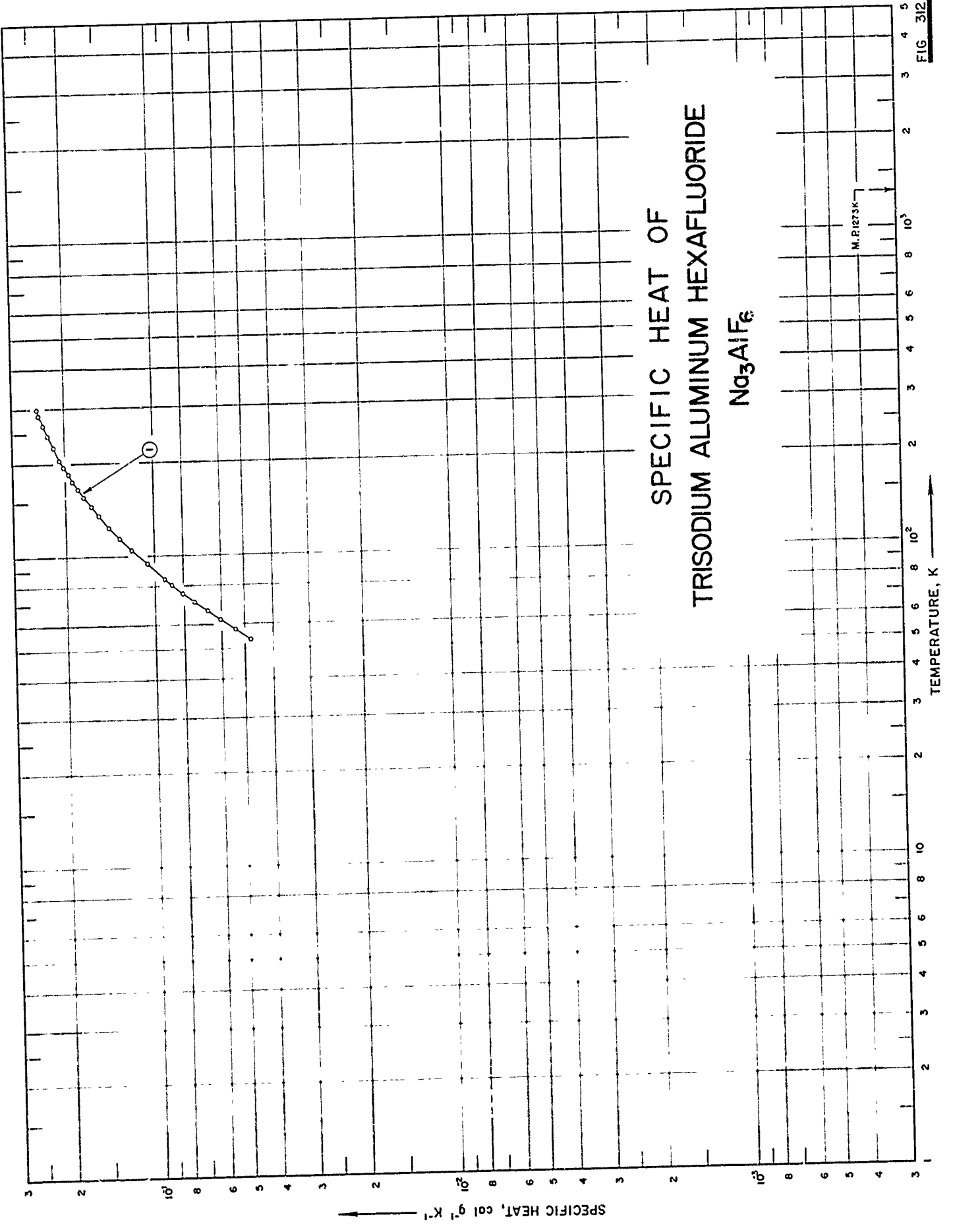

SPECIFICATION TABLE NO. 312 SPECIFIC HEAT OF TRISODIUM ALUMINUM HEXAFLUORIDE Na_3AlF_6

[For Data Reported in Figure and Table No. 312]

Curve No.	Ref. No.	Year	Temp. Range, K	Reported Error, %	Name and Specimen Designation	Composition (weight percent), Specifications and Remarks
1	279	1956	54-298			32.76 Na (32.85 theo), 13.01 Al (12.85 theo), 0.036 K, and 0.007 Li; sample supplied by the Aluminum Co. of America, Research Laboratories; corrected to stoichiometric composition.

DATA TABLE NO. 312 SPECIFIC HEAT OF TRISODIUM ALUMINUM HEXAFLUORIDE Na_3AlF_6 [Temperature, T, K; Specific Heat, C_p , Cal $\text{g}^{-1} \text{K}^{-1}$]

T	C_p
<u>CURVE 1</u>	
53.66	4.811×10^{-2}
57.94	5.425
62.32	6.078
66.53	6.730
70.94	7.402
75.55	8.097
80.79	8.835
84.45	9.340
94.77	1.070×10^{-1}
105.20	1.202
114.69	1.316
124.69	1.427
136.00	1.542
145.51	1.636
155.82	1.728
165.66	1.806
175.91	1.881
185.85	1.948
195.95	2.012
206.18	2.076
216.05	2.128*
226.05	2.177
236.20	2.224*
245.81	2.269
256.33	2.311*
266.23	2.348
276.24	2.382*
286.47	2.418
296.00	2.452*
296.15	2.458

* Not shown on plot

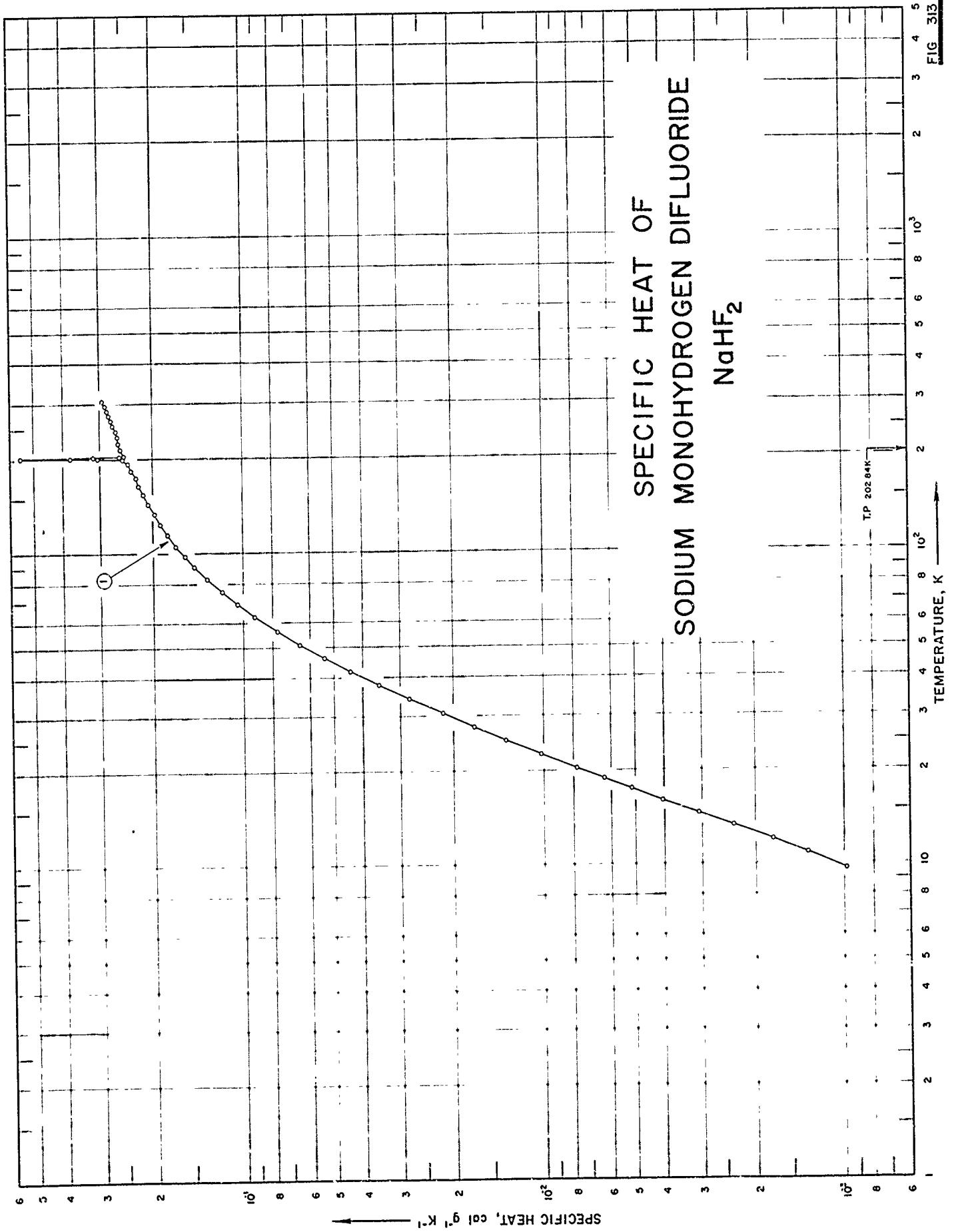

SPECIFICATION TABLE NO. 313 SPECIFIC HEAT OF SODIUM MONOHYDROGEN DIFLUORIDE NaHF_2

[For Data Reported in Figure and Table No. 313]

Curve No.	Ref. No.	Year	Temp. Range, K	Reported Error, %	Name and Specimen Designation	Composition (weight percent), Specifications and Remarks
1	290	1961	6-305			Obtained from Na_2CO_3 .

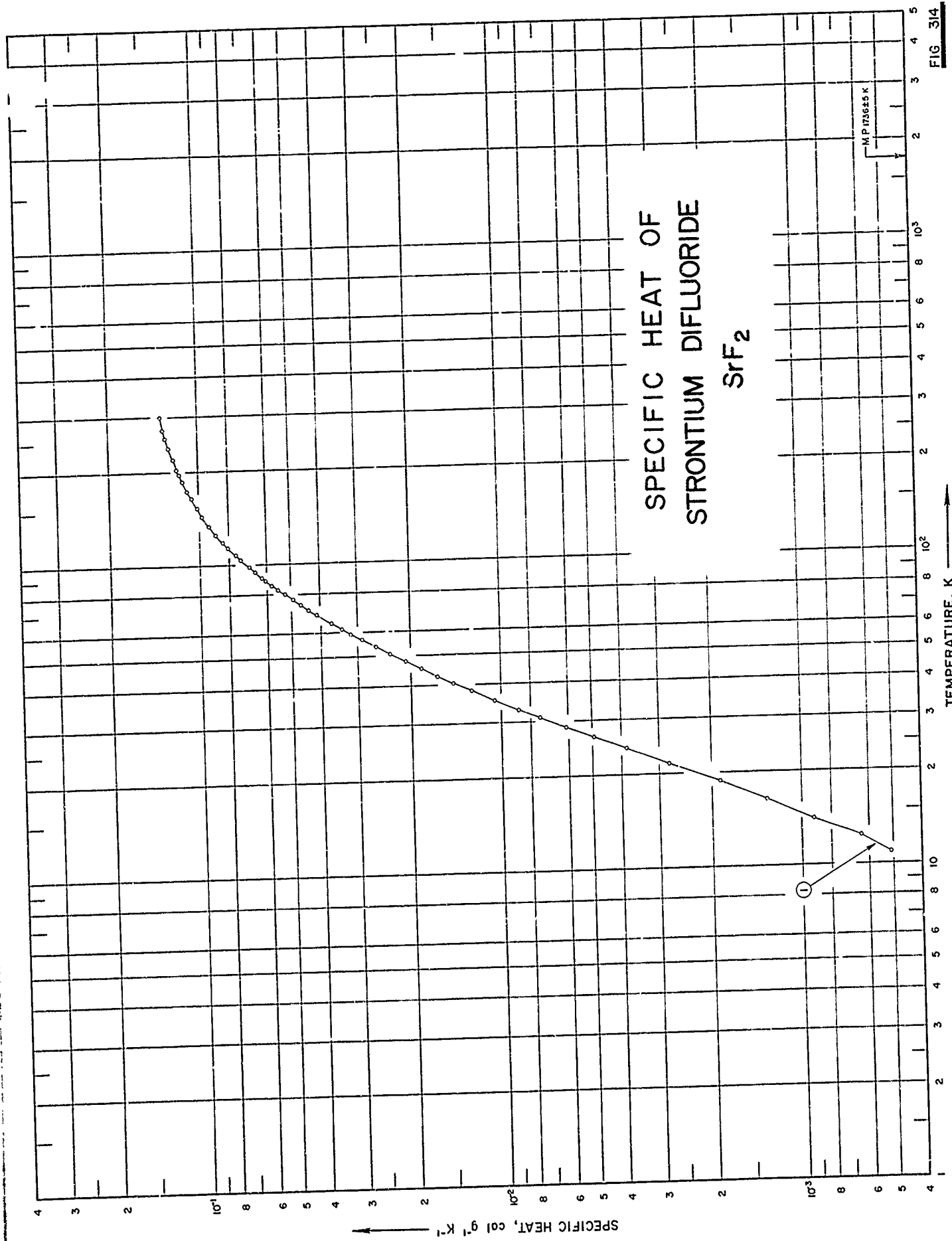

SPECIFICATION TABLE NO. 314 SPECIFIC HEAT OF STRONTIUM DIFLUORIDE SrF_2

[For Data Reported in Figure and Table No. 314]

Curve No.	Ref. No.	Year	Temp. Range, K	Reported Error, %	Name and Specimen Designation	Composition (weight percent), Specifications and Remarks
1	276	1963	11-300			Impurities: 0.001-0.01 Ca, K, traces of Cu, Fe, and Mg; washed and dried for several hrs at 600 C.

DATA TABLE NO. 314 SPECIFIC HEAT OF STRONTIUM DIFLUORIDE SrF₂
 [Temperature, T, K; Specific Heat, C_p, Cal g⁻¹ K⁻¹]

T	C _p	CURVE 1		T	C _p	CURVE 1 (cont.)		T	C _p	CURVE 1 (cont.)	
		10 ⁻⁴	10 ⁻³			10 ⁻²	10 ⁻¹			10 ⁻²	10 ⁻¹
10.94	5.095			98.67	6.863			204.40	1.183		
12.38	6.369			101.38	7.079			208.88	1.193		
14.08	9.195			101.63	7.096			212.68	1.202		
16.47	1.314	10 ⁻³		104.49	7.318			216.55	1.210		
18.93	1.879			104.68	7.333			220.40	1.218		
21.56	2.754			106.27	7.450			224.11	1.225		
24.36	3.845			107.88	7.571			227.23	1.230		
26.63	4.928			109.20	7.667			231.21	1.238		
28.73	6.090			110.98	7.798			235.78	1.245		
30.94	7.419			112.21	7.881			239.88	1.253		
32.96	8.773			114.00	8.001			244.94	1.261		
35.42	1.051	10 ⁻²		115.26	8.092			249.15	1.267		
38.22	1.258			116.37	8.201			253.34	1.274		
40.59	1.443			118.45	8.375			254.81	1.276		
42.86	1.630			121.14	8.486			257.50	1.280		
45.34	1.825			123.99	8.661			257.54	1.280		
48.04	2.076			125.51	8.747			258.99	1.282		
50.94	2.349			126.82	8.835			261.63	1.286		
53.81	2.621			128.51	8.932			263.14	1.288		
56.64	2.893			131.78	9.116			265.74	1.292		
57.05	2.934			134.99	9.298			270.86	1.299		
59.25	3.153			138.09	9.459			273.87	1.303		
59.64	3.191			141.13	9.517			273.88	1.303		
61.45	3.375			144.13	9.760			278.66	1.310		
62.02	3.431			147.23	9.911			282.09	1.314		
64.45	3.678			150.14	1.004	10 ⁻¹		285.13	1.318		
66.74	3.905			153.01	1.017			289.96	1.323		
68.91	4.118			155.85	1.029			295.29	1.328		
71.43	4.368			161.20	1.050			300.05	1.334		
74.30	4.649			162.26	1.054						
77.26	4.937			165.57	1.067						
81.79	5.378			168.84	1.080						
83.22	5.519			172.04	1.091						
84.29	5.617			174.38	1.099						
85.99	5.781			177.10	1.107						
86.91	5.864			180.24	1.117						
88.65	6.023			183.34	1.127						
89.41	6.091			186.42	1.136						
91.21	6.244			189.48	1.144						
92.24	6.365			192.48	1.144						
93.69	6.453			192.51	1.153						
95.28	6.583			193.73	1.157						
95.99	6.645			197.39	1.166						
98.24	6.827			198.50	1.169						
				201.18	1.176						

* Not shown on plot

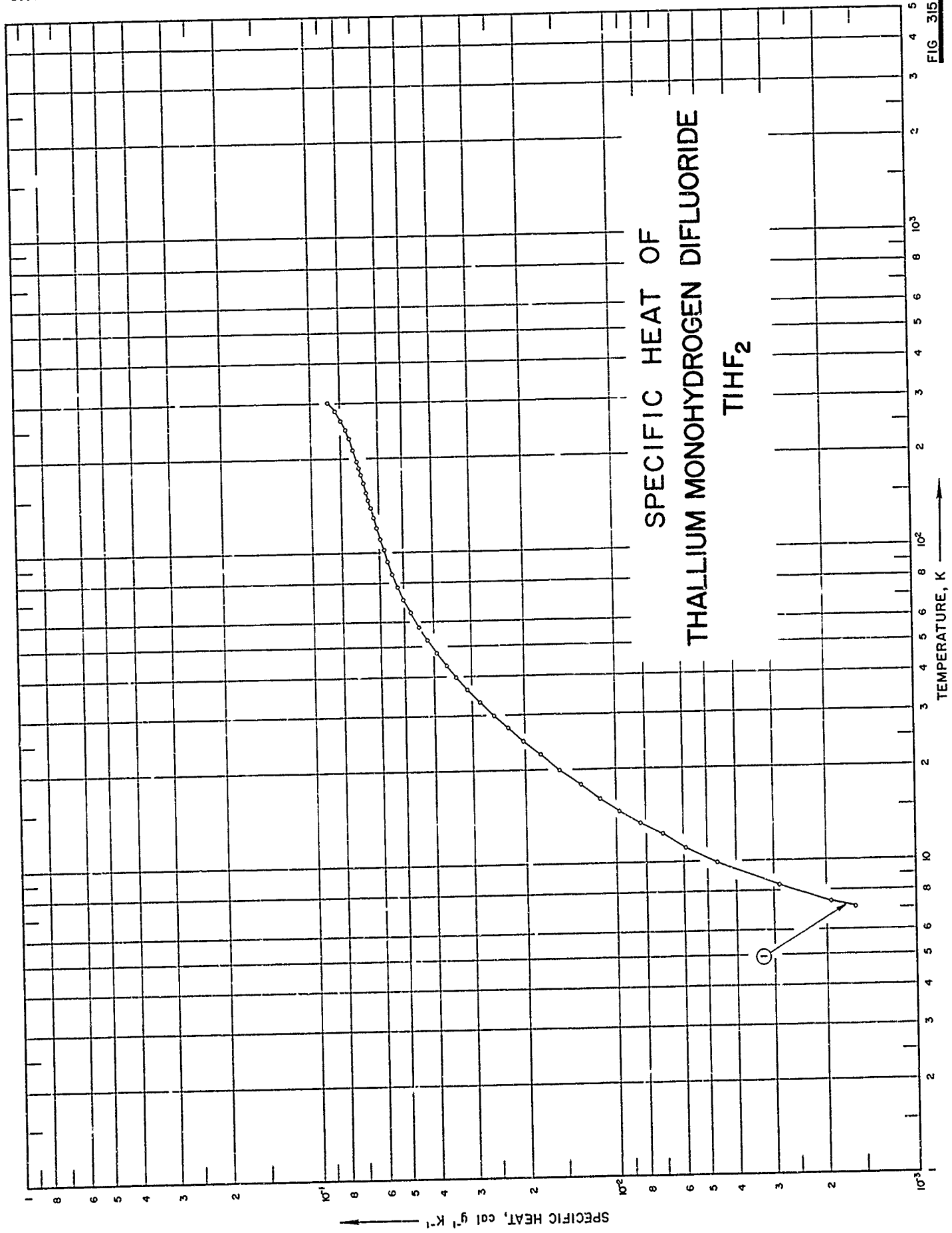

FIG. 315

SPECIFICATION TABLE NO. 315 SPECIFIC HEAT OF THALLIUM MONOHYDROGEN DIFLUORIDE THF₂

[For Data Reported in Figure and Table No. 315]

Curve No.	Ref. No.	Year	Temp. Range, K	Reported Error, %	Name and Specimen Designation	Composition (weight percent), Specifications and Remarks
1	286	1961	7-301			

DATA TABLE NO. 315 SPECIFIC HEAT OF THALLIUM MONOHYDROGEN DIFLUORIDE TlHF_2 [Temperature, T, K; Specific Heat, C_p , Cal $\text{g}^{-1} \text{K}^{-1}$]

T	C_p	T	C_p
CURVE 1		CURVE 1 (cont.)	
Series 1		Series 2 (cont.)	
158.10	6.643×10^{-2}	57.63	4.495×10^{-2}
167.53	6.742	52.78	4.232
177.00	6.857	58.52	4.532
186.18	6.964	64.34	4.799
195.73	7.076	70.59	5.029
204.83	7.169	77.45	5.255
213.85	7.272	85.06	5.481
222.80	7.379	93.50	5.674
231.86	7.490	102.15	5.838
220.22	7.338	110.95	5.994
229.13	7.453	120.01	6.138
238.03	7.568	129.01	6.270
246.94	7.695	138.04	6.393
255.88	7.827	147.11	6.508
264.91	7.975	156.25	6.619
273.98	8.139		
283.05	8.320		
292.07	8.537		
300.97	8.804		
Series 2		Series 2	
7.08	1.606×10^{-3}		
7.36	1.939		
8.34	2.884		
9.84	4.651		
11.14	5.920		
12.28	7.009		
13.45	8.377		
11.69	9.778		
16.06	1.130×10^{-2}		
17.82	1.313		
19.92	1.542		
22.28	1.789		
24.72	2.039		
27.24	2.287		
29.93	2.548		
33.02	2.827		
36.29	3.108		
39.74	3.383		
43.43	3.650		
47.65	3.932		
52.50	4.224		

* Not shown on plot

SPECIFIC HEAT OF
THORIUM TETRAFLUORIDE
 ThF_4

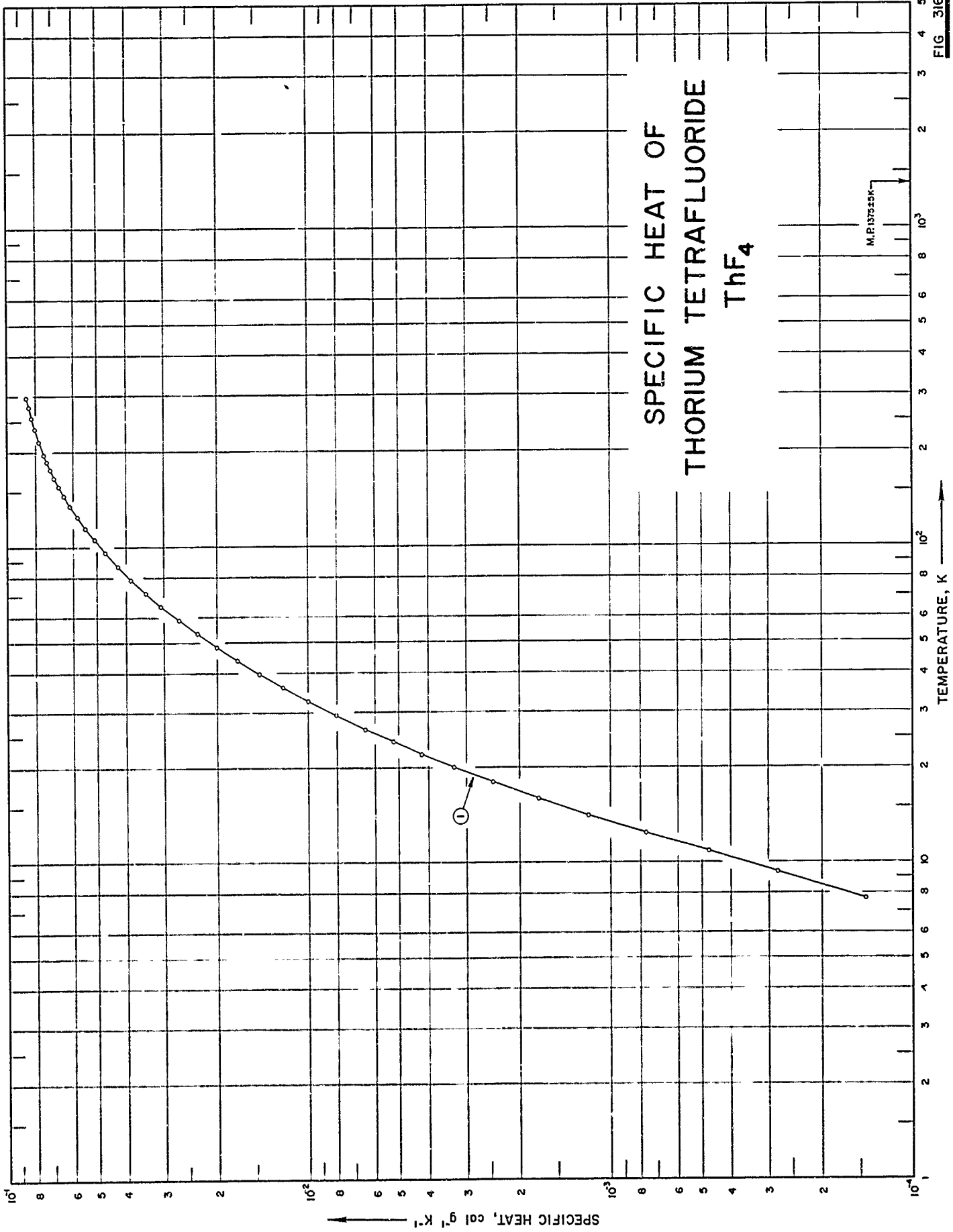

SPECIFICATION TABLE NO. 316 SPECIFIC HEAT OF THORIUM TETRAFLUORIDE ThF₄

[For Data Reported in Figure and Table No. 316]

Curve No.	Ref. No.	Year	Temp. Range, K	Reported Error, %	Name and Specimen Designation	Composition (weight percent), Specifications and Remarks
1	296	1954	6-298	0.1-5		75.33 Th (75.33 theo), 24.6 F (24.67 theo); 0.13 unconverted ThO ₂ , 0.007 Ca, 0.001 Mg, <0.001 K, 0.0005 each Fe, Na, Ni, and <0.0005 each Ag, Al, Be, Bi, Co, Cr, Cu, Li, Mn, Pb, and Sn; prepared by hydrofluorination of pure sample of electrically fused ThO ₂ .

DATA TABLE NO. 316 SPECIFIC HEAT OF THORIUM TETRAFLUORIDE ThF_4
 [Temperature, T, K; Specific Heat, C_p , Cal $\text{g}^{-1} \text{K}^{-1}$]

T	C_p
	<u>CURVE 1</u>
5.54	5.193×10^{-3} *
7.67	1.428×10^{-4}
9.31	2.791
10.86	4.738
12.47	7.659
14.12	1.185×10^{-3}
15.98	1.733
18.02	2.454
20.07	3.291
22.14	4.229
24.21	5.238
26.59	6.494
29.43	8.078
32.62	9.990
36.06	1.212×10^{-2}
39.79	1.451
44.02	1.721
48.54	2.015
53.48	2.334
59.02	2.684
59.42	2.708*
65.42	3.077
71.92	3.450
79.31	3.859
87.18	4.284
96.65	4.706
106.08	5.105
115.58	5.475
125.48	5.829
135.92	6.163
146.33	6.465
156.48	6.721
166.57	6.958
176.73	7.166
186.98	7.358
197.04	7.523
206.90	7.676*
216.84	7.809
227.16	7.942*
237.60	8.059
247.88	8.172*
258.06	8.270
268.18	8.364*
278.25	8.445
288.25	8.519*
298.17	8.588

* Not shown on plot

SPECIFIC HEAT OF
TITANIUM TETRAFLUORIDE
TiF₄

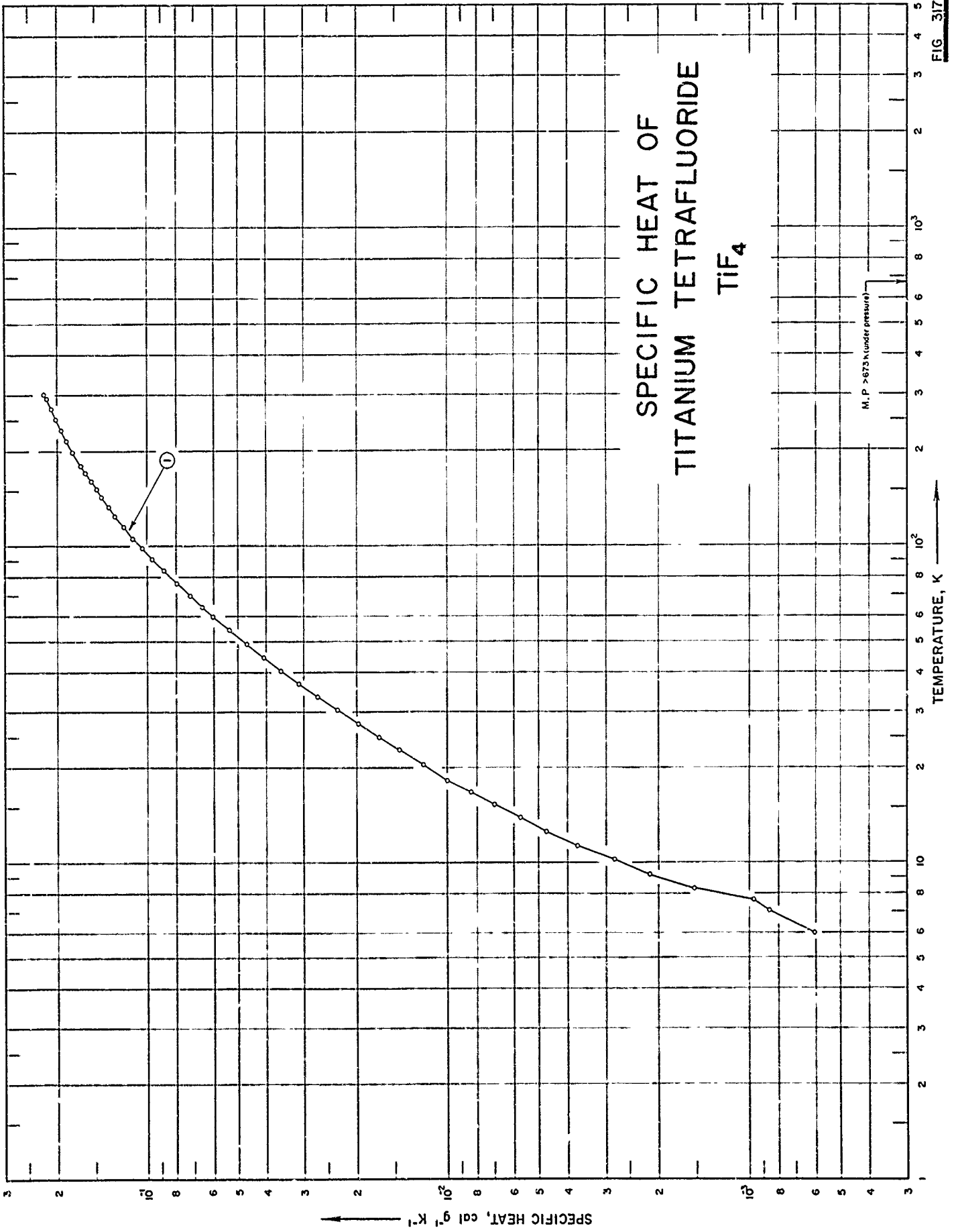

FIG. 317

SPECIFICATION TABLE NO. 317 SPECIFIC HEAT OF TITANIUM TETRAFLUORIDE TiF_4

[For Data Reported in Figure and Table No. 317]

Curve No.	Ref. No.	Year	Temp. Range, K	Reported Error, %	Name and Specimen Designation	Composition (weight percent), Specifications and Remarks
1	297	1961	6-302	0.1-5		99.9 TiF_4 ; sample supplied by the General Chemical Division of Allied Chemical and Dye Corp.; finely divided white sample; prepared by reaction of element F_2 on pure TiO_2 and purified by sublimation in nickel reactors; measured in a nitrogen atmosphere.

DATA TABLE NO. 317 SPECIFIC HEAT OF TITANIUM TETRAFLUORIDE TiF_4 [Temperature, T, K; Specific Heat, C_p , Cal $g^{-1} K^{-1}$]

T	C_p	T	C_p
CURVE 1		CURVE 1 (cont.)	
Series 1			
59.43	5.944×10^{-2} *	16.76	8.370×10^{-2}
64.57	6.584	18.42	1.000×10^{-2}
70.02	7.224	20.52	1.211
76.58	7.994	22.80	1.457
84.02	8.854	25.01	1.700
91.68	9.701	27.60	1.991
99.40	1.045×10^{-1}	30.53	2.338
107.44	1.123	33.59	2.713
116.12	1.203	36.93	3.129
125.04	1.283	40.63	3.585
133.96	1.356	44.75	4.086
142.87	1.424	49.43	4.689
151.90	1.487	54.70	5.350
161.26	1.553	60.38	6.057
170.85	1.615	Series 3	
180.15	1.672	246.39	1.998×10^{-1} *
189.34	1.723*	255.26	2.036*
198.31	1.773	264.83	2.077*
207.09	1.818*	274.54	2.110*
215.89	1.862	284.09	2.153*
224.78	1.906*	292.34	2.183*
233.81	1.947	300.45	2.213*
243.02	1.989*	Series 2	
252.21	2.023*	6.32	6.053×10^{-1}
261.69	2.063*	7.06	8.555
271.80	2.103	7.68	9.685
282.34	2.146*	8.35	1.525×10^{-3}
292.74	2.184	9.26	2.147
301.54	2.224	10.21	2.809
		11.35	3.721
		12.68	4.705
		13.94	5.755
		15.28	6.990

* Not shown on plot

FIG 318

SPECIFIC HEAT OF URANIUM TETRAFLUORIDE UF₄

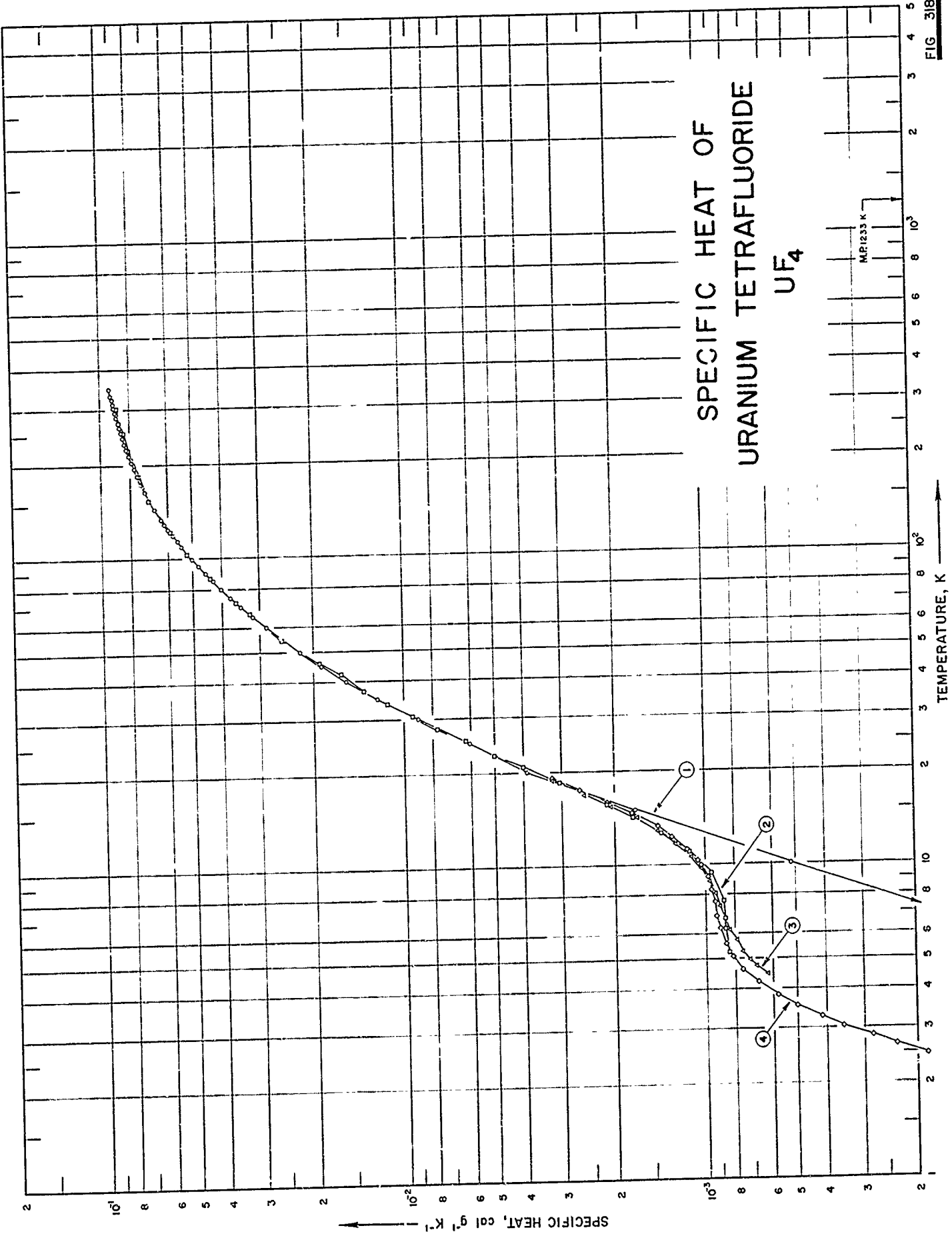

SPECIFICATION TABLE NO. 318 SPECIFIC HEAT OF URANIUM TETRAFLUORIDE UF₄

[For Data Reported in Figure and Table No. 318]

Curve No.	Ref. No.	Year	Temp. Range, K	Reported Error, %	Name and Specimen Designation	Composition (weight percent), Specifications and Remarks
1	298	1948	5-350			2.0 UO ₂ F ₂ .
2	299	1955	5-304			75.83 ± 0.07 U and 24.15 ± 0.06 F (75.80 and 24.20 theo), 0.006 ± 0.003 oxygen corrected to 0.05 UO ₂ F ₂ , < 0.01 Pt, < 0.005 Ti, and < 0.002 each Ag, Al, As, Be, Bi, Ca, Co, Cr, Cu, Fe, K, Li, Mg, Mn, Mo, Na, Ni, P, Pb, Sb, Sn, Ta, Zr, and 0.0015 rare earth; sample supplied by the Malinkrodt Chem. Co. prepared from sample by sublimating twice under vacuum at 1100 C for several hrs.
3	300	1960	4.4-18	0.4-2.0		75.83 ± 0.07 U, 24.18 ± 0.06 F, < 0.01 Pt, < 0.005 Ti, and < 0.002 each Ag, Al, As, Be, Bi, Ca, Co, Cr, Cu, Fe, K, Li, Mg, Mn, Mo, Na, Ni, P, Pb, Sb, Sn, Ta and Zr; powdered form.
4	300	1960	1.6-19	0.4-2.0		75.8 U, 24.18 F, 0.004 Mo, 0.0015 Si, 0.001 Cu, 0.0006 Mg, 0.0005 Al, 0.0003 Ni, 0.0002 Zr, 0.00008 Cr, 0.00002 Ba, and 0.00001 each Li and Mn; granular; melted by induction heating at about 1000 C under helium atmosphere.

DATA TABLE NO. 318 SPECIFIC HEAT OF URANIUM TETRAFLUORIDE UF₄[Temperature, T, K; Specific Heat, C_p, Cal g⁻¹ K⁻¹]

T	C _p	T	C _p	T	C _p	T	C _p	T	C _p
5.00	6.089 x 10 ^{-3*}	230.00	8.290 x 10 ^{-2*}	33.73	1.133 x 10 ⁻²	Series 1 (cont.)	Series 1 (cont.)	CURVE 3 (cont.)	Series 4 (cont.)
10.00	5.176 x 10 ⁻⁴	235.00	8.350	37.22	1.363	41.13	1.622	6.712	8.660 x 10 ⁻⁴
15.00	1.705 x 10 ⁻³	240.00	8.408*	45.39	1.906	49.92	2.209	7.350	8.966
20.00	3.905	245.00	8.464*	54.80	2.528	60.11	2.868	8.814	9.291
25.00	6.036	250.00	8.516*	60.11	2.868	66.31	3.254	8.820	9.676
30.00	8.981	255.00	8.567	66.31	3.254	72.63	3.620	9.737	9.560*
35.00	1.229 x 10 ⁻²	260.00	8.616*	72.63	3.620	78.97	4.009	10.680	1.031 x 10 ⁻³
40.00	1.560	265.00	8.662	78.97	4.009	85.22	4.407	11.748	1.120
45.00	1.891	270.00	8.708*	85.22	4.407	91.44	4.801	12.888	1.257
50.00	2.224	273.16	8.738*	86.96	4.407	95.22	4.801	14.072	1.449
55.00	2.558	275.00	8.755	95.22	4.801	104.44	5.209	15.456	1.697
60.00	2.871	280.00	8.801*	104.44	5.209	114.06	5.601	16.976	2.052
65.00	3.185	285.00	8.844	123.95	5.970	134.43	6.327	18.497	3.053
70.00	3.487	290.00	8.886*	134.43	6.327	145.14	6.651	Series 2	
75.00	3.771	295.00	8.926	145.14	6.651	155.50	6.932	4.177	6.674 x 10 ^{-4*}
80.00	4.045	298.16	8.952*	155.50	6.932	165.59	7.174	Series 3	
85.00	4.307	300.00	8.967*	165.59	7.174	175.31	7.384	2.486	1.856 x 10 ⁻⁴
90.00	4.558	305.00	9.006	175.31	7.384	184.84	7.565	2.652	2.350
95.00	4.796	310.00	9.045*	184.84	7.565	194.39	7.734	2.808	2.799
100.00	5.020	315.00	9.084	194.39	7.734	204.20	7.890	3.014	3.528
105.00	5.240	320.00	9.122*	204.20	7.890	214.29	8.021	3.253	4.184
110.00	5.450	325.00	9.159	214.29	8.021	224.48	8.164	3.524	4.989
115.00	5.652	330.00	9.195*	224.48	8.164	234.69	8.288	3.830	5.836
125.00	6.027	340.00	9.266*	234.69	8.288	244.92	8.396	4.197	6.715
130.00	6.203	345.00	9.301*	244.92	8.396	255.00	8.492	4.606	7.514
135.00	6.368	350.00	9.334	255.00	8.492	264.94	8.584	5.062	8.154
140.00	6.520*			264.94	8.584	274.75	8.664	5.595	8.651
145.00	6.665			274.75	8.664	284.43	8.734	6.226	8.998
150.00	6.804*			284.43	8.734	294.11	8.801	7.541	9.211
155.00	6.937			294.11	8.801	303.79	8.864	8.280	9.374
160.00	7.066*			303.79	8.864			8.982	9.552
165.00	7.187							Series 1	
170.00	7.301*							4.442	6.244 x 10 ⁻⁴
175.00	7.409							4.726	6.817
180.00	7.509							4.972	7.158
185.00	7.606							5.293	7.556
190.00	7.696*							5.713	7.966
195.00	7.782							6.142	8.317
200.00	7.864*								
205.00	7.943								
210.00	8.018*								
215.00	8.092								
220.00	8.162*								
225.00	8.228								

* Not shown on plot

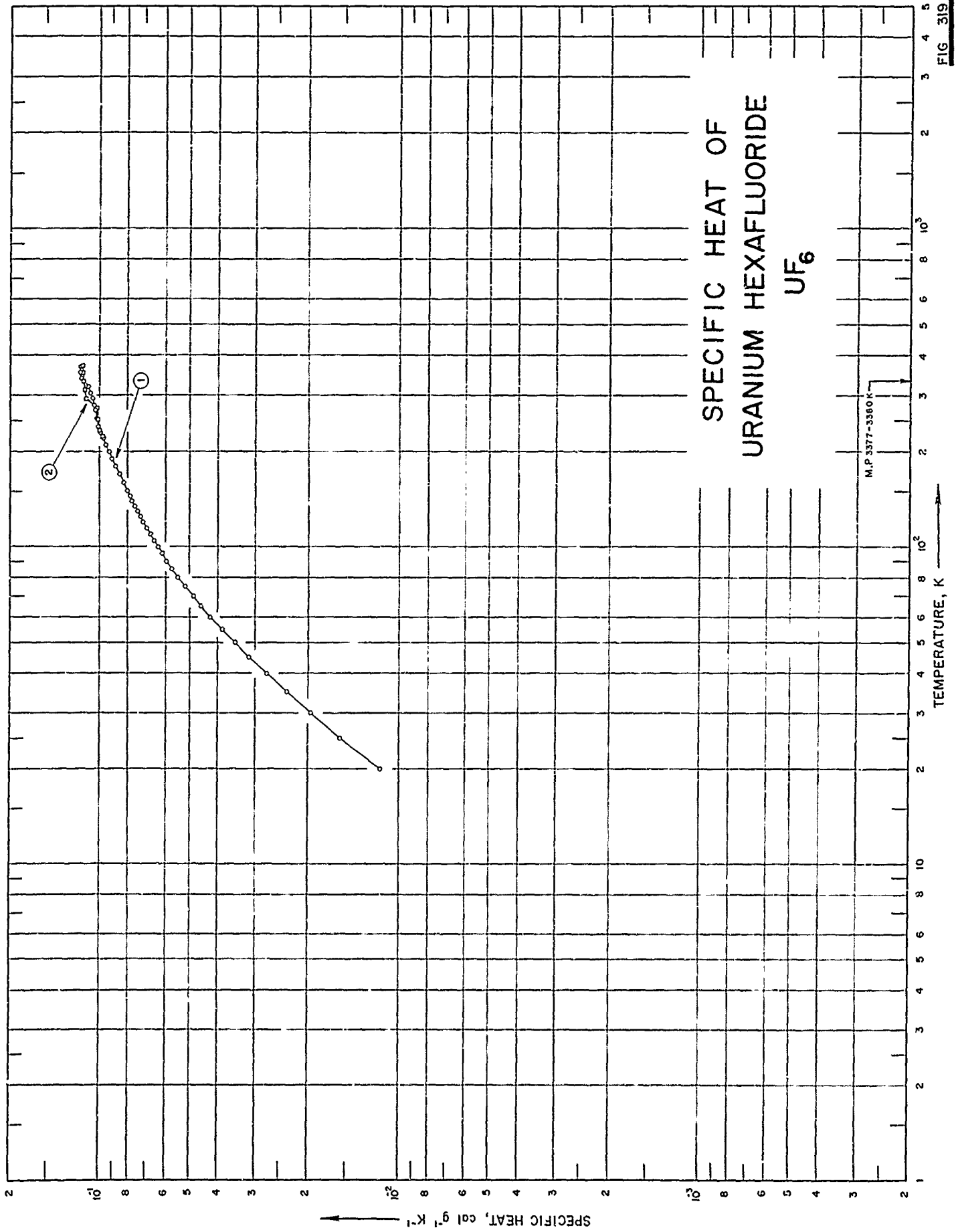

FIG 319

SPECIFICATION TABLE NO. 319 SPECIFIC HEAT OF URANIUM HEXAFLUORIDE UF₆

[For Data Reported in Figure and Table No. 319]

Curve No.	Ref. No.	Year	Temp. Range, K	Reported Error, %	Name and Specimen Designation	Composition (weight percent), Specifications and Remarks
1	298	1948	20-370			2 x 10 ⁻¹ mole fraction impurities.
2	301	1953	223-373	1.0		SF ₄ chief impurity; purified by repeated distillation; under 10 ⁻⁶ mm vacuum.

DATA TABLE NO. 319 SPECIFIC HEAT OF URANIUM HEXAFLUORIDE UF₆
 [Temperature, T, K; Specific Heat, C_p, Cal g⁻¹ K⁻¹]

T	C _p	T	C _p
20	1.154 x 10 ⁻²	245	1.025 x 10 ^{-1*}
25	1.571	250	1.035*
30	1.966	255	1.045
35	2.349	260	1.055*
40	2.737	265	1.065*
45	3.124	270	1.075
50	3.505	273.16	1.082*
55	3.879	275	1.085*
60	4.232	280	1.095
65	4.565	283	1.105*
70	4.875	290	1.115*
75	5.176	295	1.125
80	5.454	298.16	1.132*
85	5.720	300	1.136*
90	5.961	305	1.148
95	6.181	310	1.161*
100	6.387	315	1.174*
105	6.581	320	1.187
110	6.766	325	1.201*
115	6.949	330	1.215*
120	7.123	335	1.229
125	7.289	(s) 337.21	1.232*
130	7.450	(l) 337.21	1.295*
135	7.604	340	1.297
140	7.754	345	1.302*
145	7.895	350	1.307*
150	8.038	355	1.312
155	8.173*	360	1.316*
160	8.306	365	1.320*
165	8.438*	370	1.324
170	8.565		
175	8.691*		
180	8.813		
185	8.925*		
190	9.051		
195	9.165*		
200	9.275		
205	9.386*		
210	9.503		
215	9.595*		
220	9.721		
225	9.827*		
230	9.931		
235	1.004 x 10 ^{-1*}		
240	1.014		

T	C _p
233.15	9.71 x 10 ⁻²
243.15	9.82
253.15	1.01 x 10 ⁻¹
273.15	1.05
293.15	1.11
313.15	1.19
333.15	1.26
343.15	1.35*
353.15	1.37
363.15	1.39*
373.15	1.41

* Not shown on plot

FIG. 320

SPECIFIC HEAT OF VANADIUM TRIFLUORIDE VF₃

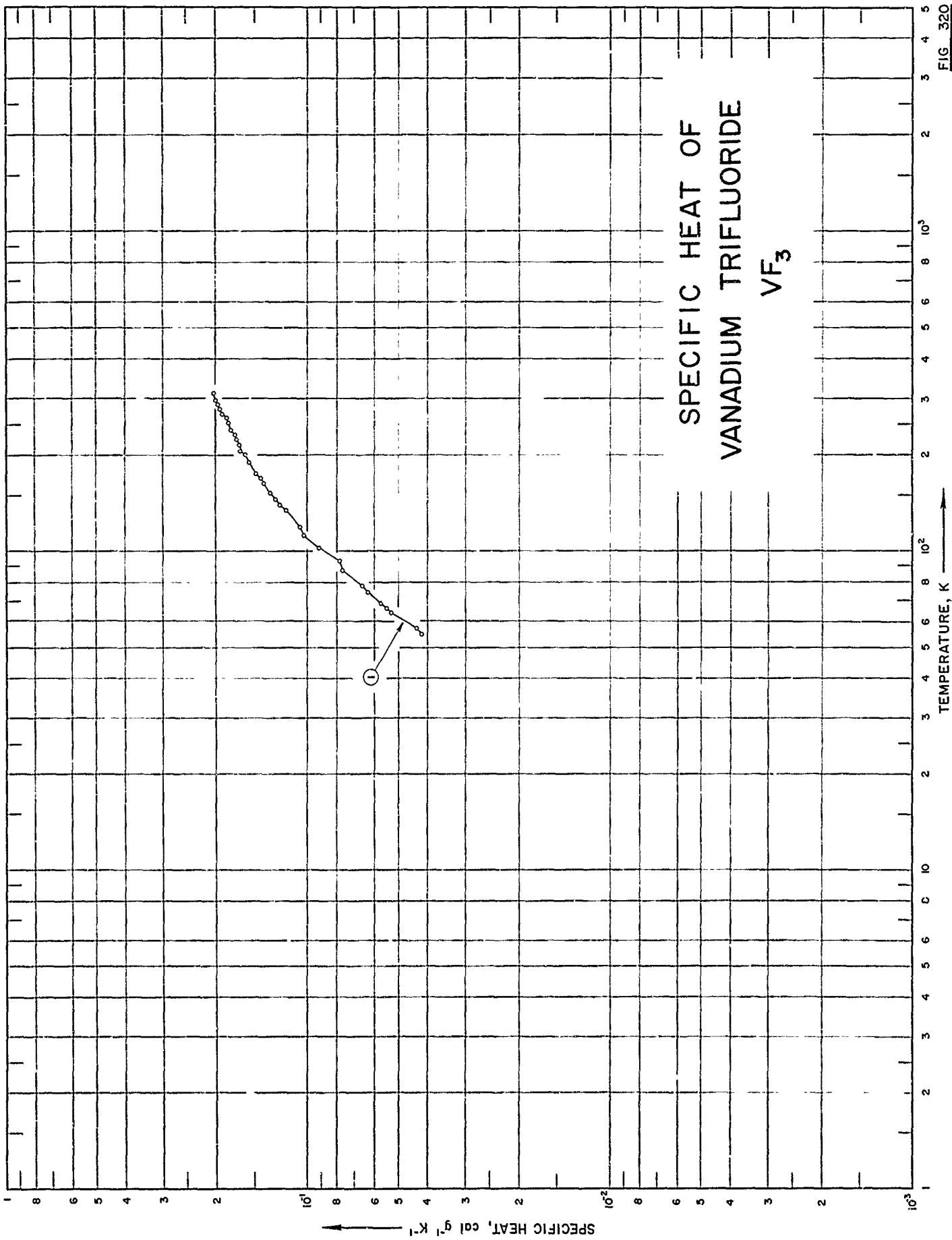

SPECIFICATION TABLE NO. 320 SPECIFIC HEAT OF VANADIUM TRIFLUORIDE VF_3

[For Data Reported in Figure and Table No. 320]

Curve No.	Ref. No.	Year	Temp. Range, K	Reported Error, %	Name and Specimen Designation	Composition (weight percent), Specifications and Remarks
1	332	1957	55-315			52.8 F_2 and 46.5 V.

DATA TABLE NO. 320 SPECIFIC HEAT OF VANADIUM TRIFLUORIDE VF₃[Temperature, T, K; Specific Heat, C_p, Cal g⁻¹ K⁻¹]

T	C _p		T	C _p	
	CURVE 1			CURVE 1 (cont.)	
54.89	4.225	10 ⁻²	269.61	1.928	10 ⁻¹
57.77	4.391		273.24	1.921*	
64.19	5.318		275.52	1.924*	
66.53	5.466		279.78	1.960	
68.79	5.744		284.23	1.977*	
74.64	6.318		287.16	1.973*	
78.11	6.578		289.98	1.982	
87.40	7.643		292.87	1.975*	
90.31	7.819		295.61	1.992	
102.87	9.153		298.33	2.003	
105.41	9.265*		305.89	2.035*	
113.83	1.028	10 ⁻¹	308.46	2.035*	
116.71	1.047*		311.87	2.038	
118.11	1.059*		315.04	2.051	
120.30	1.070				
128.45	1.153*				
135.39	1.190				
140.57	1.241				
143.65	1.231*				
146.38	1.298				
153.77	1.334*				
155.98	1.334*				
163.57	1.400				
169.50	1.429				
173.07	1.482*				
177.43	1.487				
181.41	1.501*				
188.03	1.546*				
190.76	1.572*				
191.61	1.557				
194.03	1.581*				
197.67	1.599*				
200.82	1.614				
206.62	1.678				
209.83	1.673*				
213.76	1.684				
216.34	1.694				
218.93	1.706*				
225.66	1.735				
228.94	1.748*				
232.03	1.755				
239.88	1.800				
248.05	1.832*				
254.74	1.836				
263.90	1.871				
266.72	1.924*				

* Not shown on plot

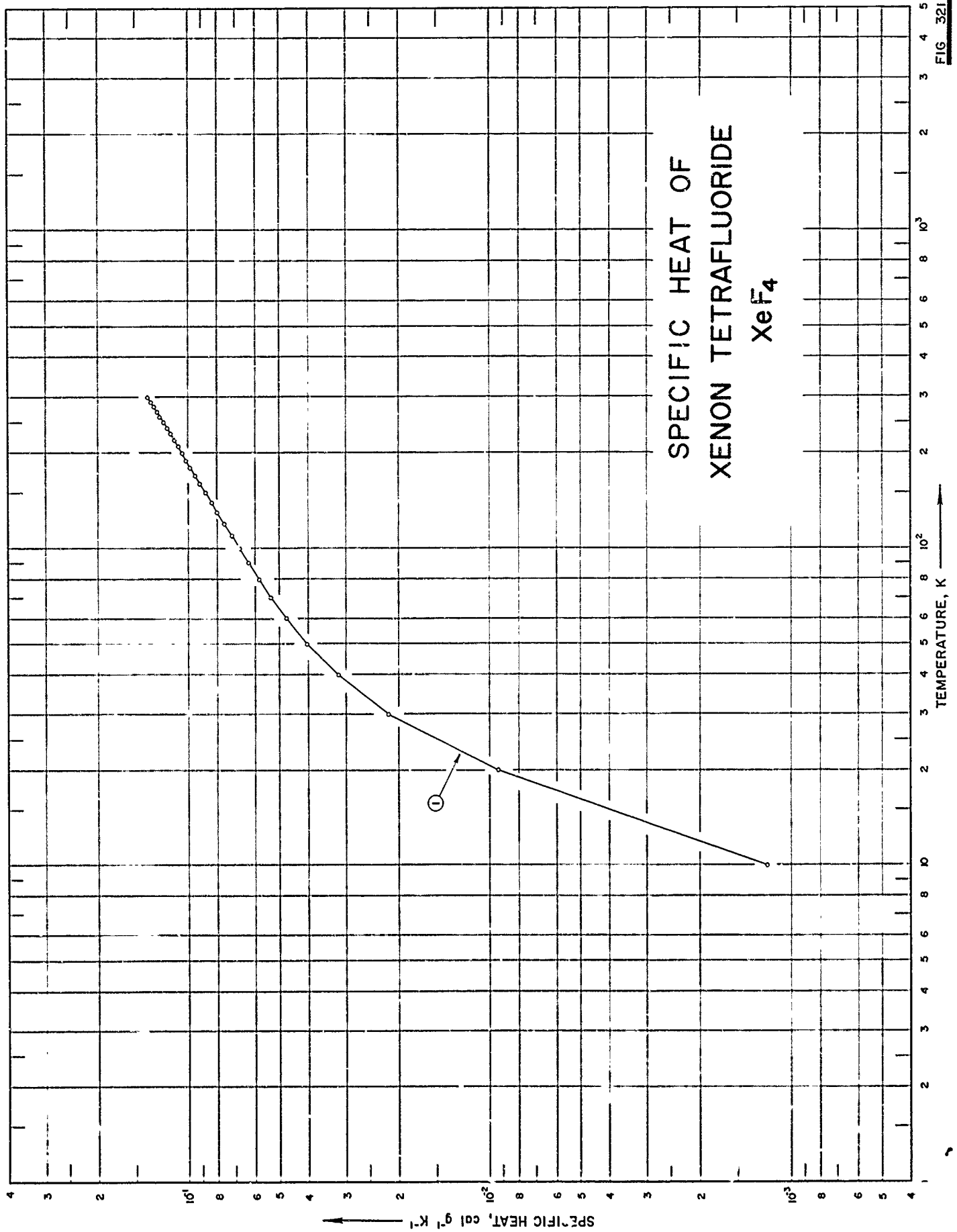

FIG. 321

SPECIFICATION TABLE NO. 321 SPECIFIC HEAT OF XENON TETRAFLUORIDE XeF_4

[For Data Reported in Figure and Table No. 321]

Curve No.	Ref. No.	Year	Temp. Range, K	Reported Error, %	Name and Specimen Designation	Composition (weight percent), Specifications and Remarks
1	334	1963	10-300			Prepared from high purity xenon and fluorine by heating to 450 C for 2.5 hrs; rapidly quenched in water.

DATA TABLE NO. 321 SPECIFIC HEAT OF XENON TETRAFLUORIDE XeF₄[Temperature, T, K; Specific Heat, C_p, Cal g⁻¹ K⁻¹]

T	C _p
10	1.200 × 10 ⁻³
20	9.300
30	2.170 × 10 ⁻²
40	3.180
50	4.030
60	4.740
70	5.320
80	5.830
90	6.310
100	6.760
110	7.190
120	7.600
130	8.000
140	8.380
150	8.740
160	9.120
170	9.470
180	9.820
190	1.016 × 10 ⁻¹
200	1.051
210	1.082
220	1.116
230	1.147
240	1.181
250	1.213
260	1.247
270	1.279
280	1.312
290	1.342
298.16	1.367*
300	1.373

* Not shown on plot

FIG. 322

SPECIFIC HEAT OF ZINC DIFLUORIDE ZnF_2

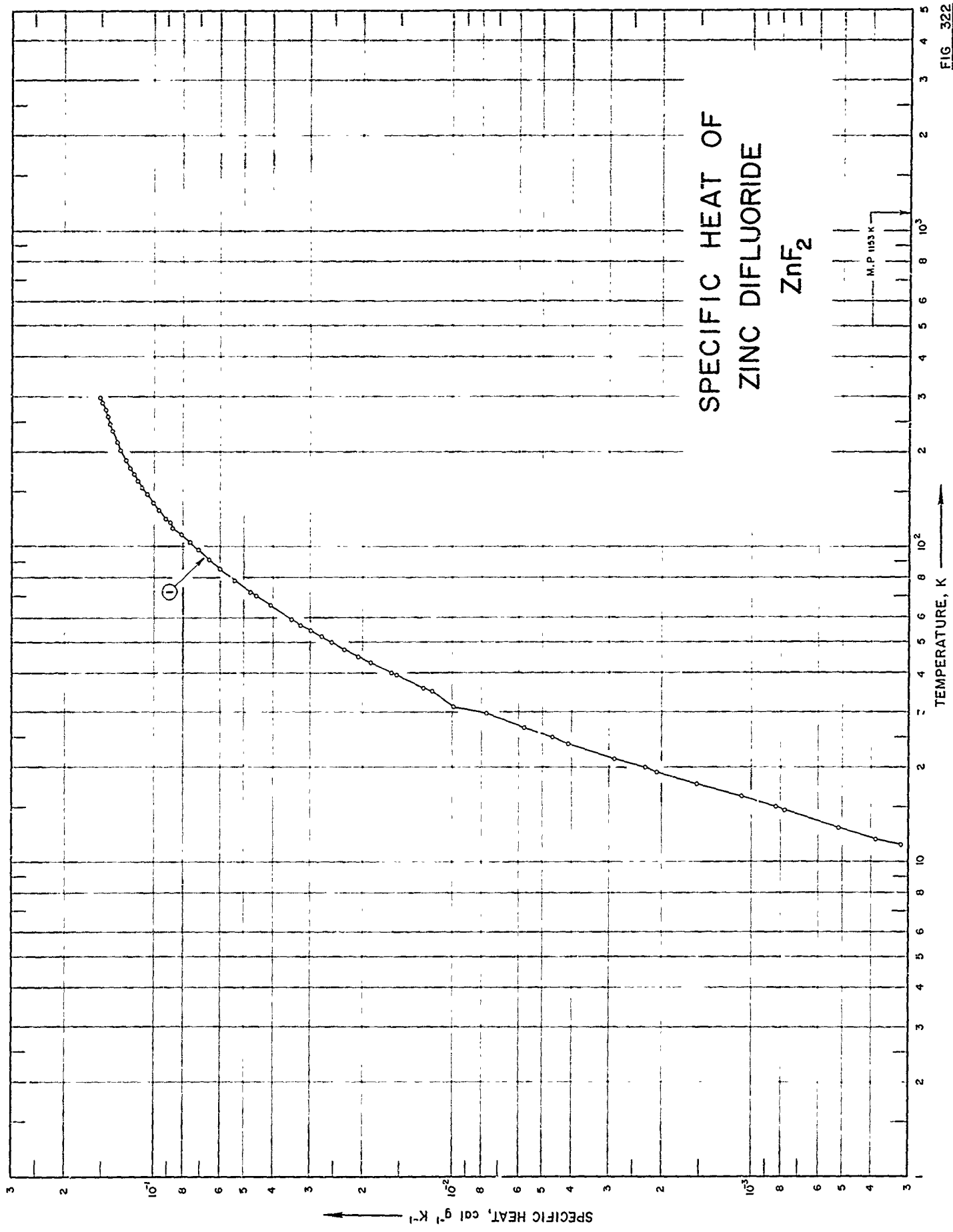

SPECIFICATION TABLE NO. 322 SPECIFIC HEAT OF ZINC DIFLUORIDE ZnF_2

[For Data Reported in Figure and Table No. 322]

Curve No.	Ref. No.	Year	Temp. Range, K	Reported Error, %	Name and Specimen Designation	Composition (weight percent), Specifications and Remarks
1	302	1955	11-299	0.5-3		53.22 Zr (63.24 theo), 0.006 Al, 0.005 Fe, 0.002 Ni, Cu, and 0.001 Mg and K; prepared from $ZnCO_3$; sintered; heated in HF atmosphere to 980 C and slowly cooled.

DATA TABLE NO. 322 SPECIFIC HEAT OF ZINC DIFLUORIDE ZnF_2 [Temperature, T, K; Specific Heat, C_p , Cal $g^{-1} K^{-1}$]

T	C_p	T	C_p
CURVE 1		CURVE J (cont.)	
Series 1			
59.18	5.480×10^{-2}	188.59	1.251×10^{-1}
54.53	3.008	195.71	1.278*
58.80	3.438*	203.00	1.302
65.25	4.088	210.03	1.324*
72.14	4.755	217.10	1.345
78.81	5.400	224.10	1.365*
85.27	6.018	233.54	1.390
91.62	6.583	240.41	1.405*
98.14	7.147	247.27	1.421
104.09	7.633	253.92	1.435*
110.31	8.119	260.57	1.449
117.03	8.638	267.49	1.462*
124.09	9.150	272.66	1.474
131.60	9.643	279.50	1.485*
139.40	1.013×10^{-1}	286.36	1.499
147.63	1.060	292.97	1.508*
155.00	1.102	299.42	1.522
162.90	1.140		
170.80	1.177		
178.91	1.212		
Series 2			
11.03	3.192×10^{-4}		
11.89	3.869		
12.96	5.127		
14.68	7.738		
16.19	1.083×10^{-3}		
17.87	1.538		
19.48	2.089		
21.47	2.883		
23.94	4.063		
26.82	5.746		
29.72	7.700		
32.72	9.934		
35.93	1.251×10^{-2}		
39.25	1.541		
43.10	1.890		
47.56	2.315		
52.10	2.756		
56.98	3.254		

* Not shown on plot

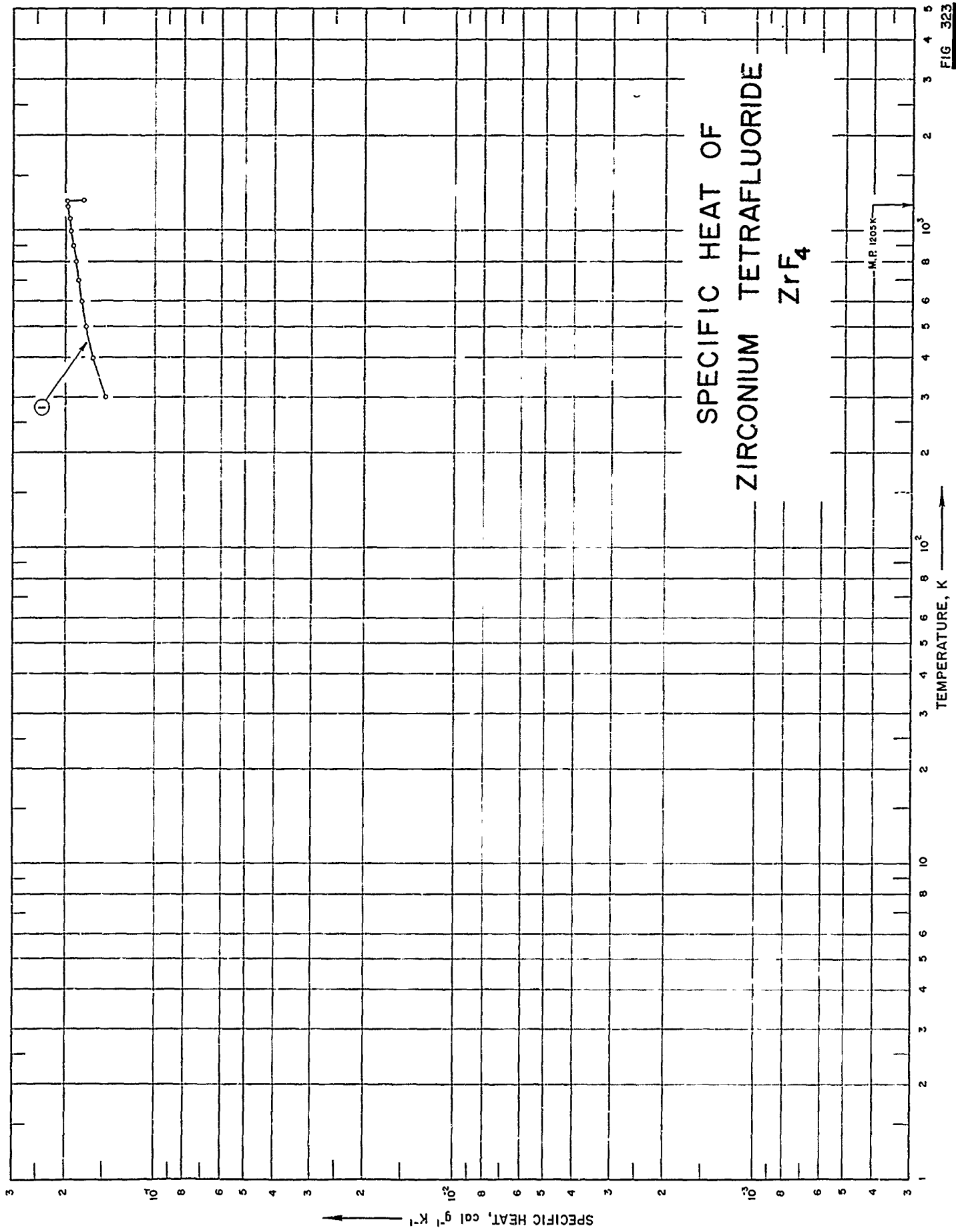

FIG 323

SPECIFICATION TABLE NO. 323 SPECIFIC HEAT OF ZIRCONIUM TETRAFLUORIDE ZrF_4

[For Data Reported in Figure and Table No. 323]

Curve No.	Ref. No.	Year	Temp. Range, K	Reported Error, %	Name and Specimen Designation	Composition (weight percent), Specifications and Remarks
1	335	1962	300-1205			54.6 Zr and 44.9 F (54.55 and 45.45 theo); scaled under 8 mm Hg helium.

DATA TABLE NO. 323 SPECIFIC HEAT OF ZIRCONIUM TETRAFLUORIDE $\frac{1}{2}\text{ZrF}_4$ [Temperature, T, K; Specific Heat, C_p , Cal g⁻¹ K⁻¹]

T	C_p
	<u>CURVE 1</u>
300	1.484 x 10 ⁻¹
400	1.621
500	1.709
600	1.771
700	1.817
800	1.852
900	1.884
1000	1.915
1100	1.946
1200	1.976
(s) 1205	1.978
(l) 1205	1.734

* Not shown on plot

FIG. 324

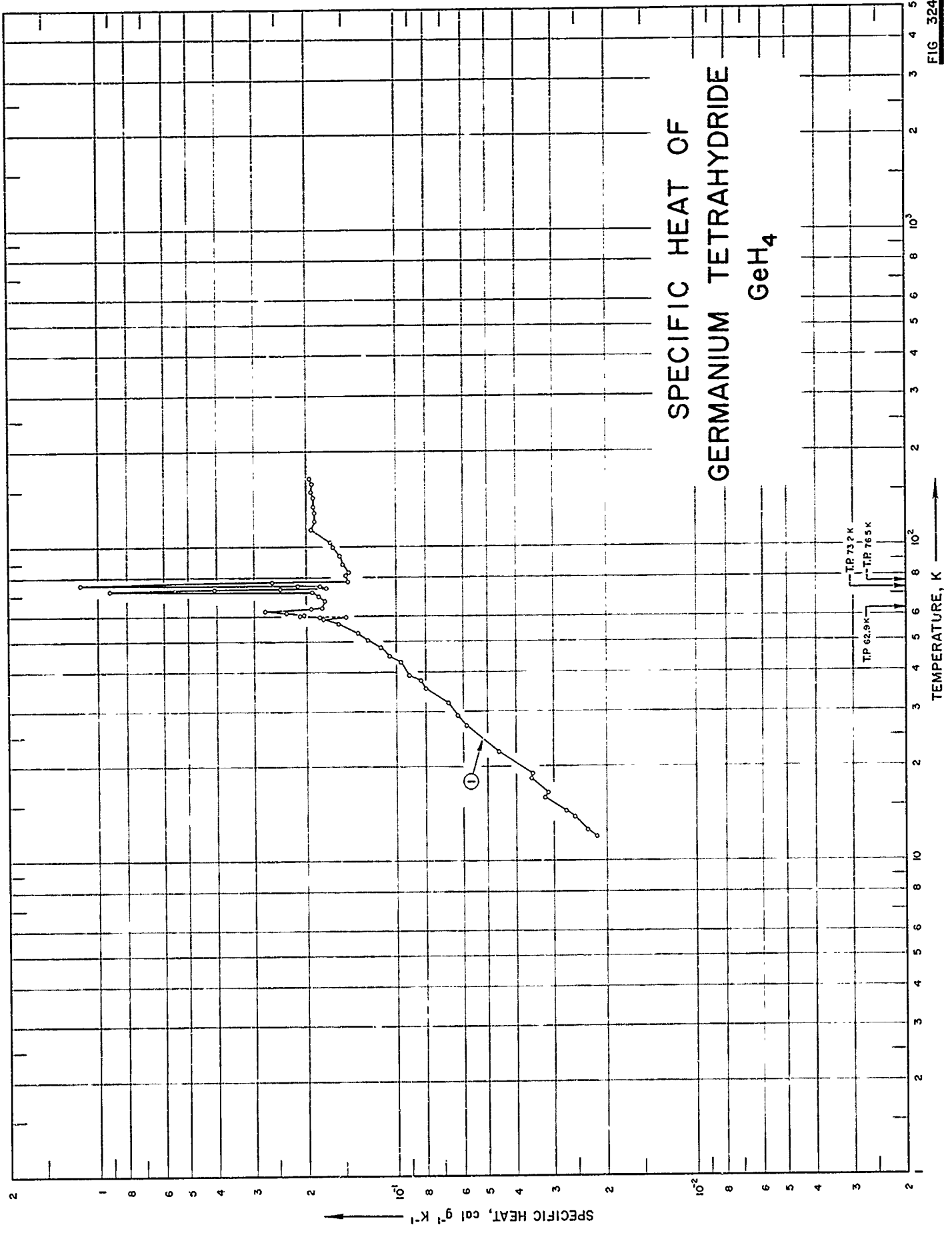

SPECIFICATION TABLE NO. 324 SPECIFIC HEAT OF GERMANIUM TETRAHYDRIDE GeH_4

[For Data Reported in Figure and Table No. 324.]

Curve No.	Ref. No.	Year	Temp. Range, K	Reported Error, %	Name and Specimen Designation	Composition (weight percent), Specifications and Remarks
1	408	1942	12-165			

DATA TABLE NO. 324 SPECIFIC HEAT OF GERMANIUM TETRAHYDRIDE GeH₄[Temperature, T, K; Specific Heat, Cp, Cal g⁻¹K⁻¹]

T	C _p	T	C _p
12.0	2.153 x 10 ⁻²	72.2	1.919 x 10 ⁻¹
12.6	2.310	72.8	9.136
13.8	2.568	73.5	4.059
14.5	2.715	73.9	2.454
16.0	3.211	74.1	1.853*
16.6	3.119	74.4	1.723
18.4	3.550	75.1	1.801
19.0	3.511	75.3	1.801*
22.3	4.581	75.4	2.140
27.1	5.860	76.3	1.146
29.2	6.265	77.5	2.597
31.9	6.748	77.6	1.462
35.5	8.001	78.2	1.475*
37.7	8.327	81.0	1.475
39.1	9.123	82.6	1.462*
40.3	9.227*	83.1	1.449
43.2	9.710	88.1	1.514
45.2	1.069 x 10 ⁻¹	89.3	1.514*
48.1	1.139	93.7	1.553
50.7	1.250	93.8	1.553*
53.4	1.357	94.6	1.553*
57.1	1.566	99.9	1.631
57.6	1.605*	101.9	1.671*
58.1	1.644*	103.9	1.671
59.0	1.723*	112.7	1.932
59.1	1.762	121.1	1.879
59.5	1.723*	127.9	1.879
59.9	1.475	134.9	1.892
59.9	1.814	143.5	1.892
60.5	2.101	150.6	1.932
60.8	2.049	158.4	1.919
61.8	2.336	165.4	1.958
62.1	2.441*		
62.6	2.662*		
62.7	2.767		
63.6	1.932		
63.7	1.853*		
64.3	1.775		
65.1	1.788*		
65.6	1.762*		
66.4	1.762*		
67.7	1.749		
68.7	1.788*		
69.9	1.827		
71.3	1.866*		

* Not shown on plot

SPECIFIC HEAT OF LITHIUM HYDRIDE LiH

CONTINUED FROM FIGURE 325-1

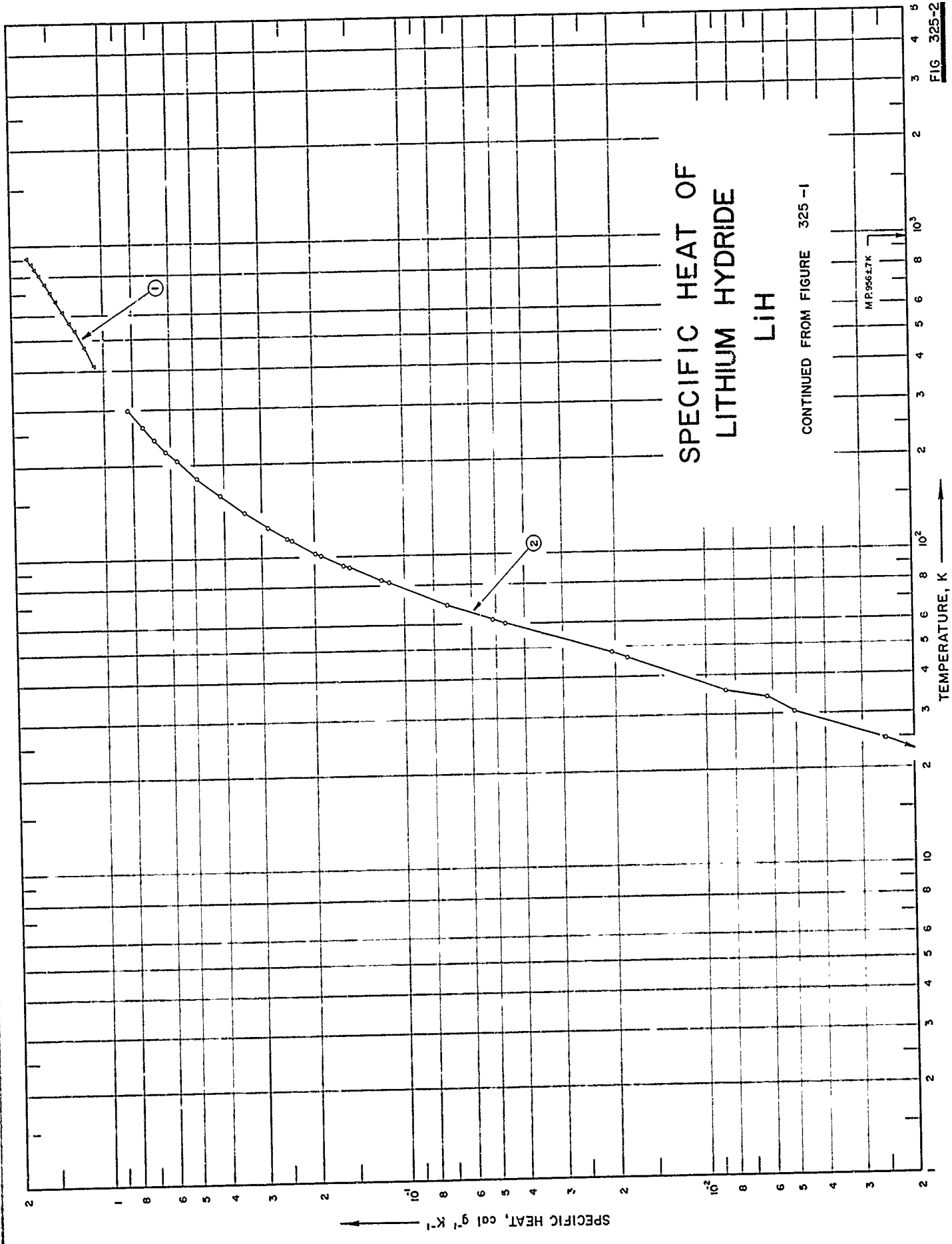

MP 966.7 K

1

2

SPECIFIC HEAT, cal g⁻¹ K⁻¹

TEMPERATURE, K

SPECIFICATION TABLE NO. 325 SPECIFIC HEAT OF LITHIUM HYDRIDE LiH

[For Data Reported in Figure and Table No. 325.]

Curve No.	Ref. No.	Year	Temp. Range, K	Reported Error, %	Name and Specimen Designation	Composition (weight percent), Specifications and Remarks
1	27	1958	413-914	0.66-2.9		Measured in helium atmosphere.
2	207	1961	3.7-296			99.8 LiH, fairly coarse, slightly colored crystals; dry nitrogen atmosphere at temperature above 12 K; helium cryostat at temperature below 12 K; results follow Debye law from 0-40 K.

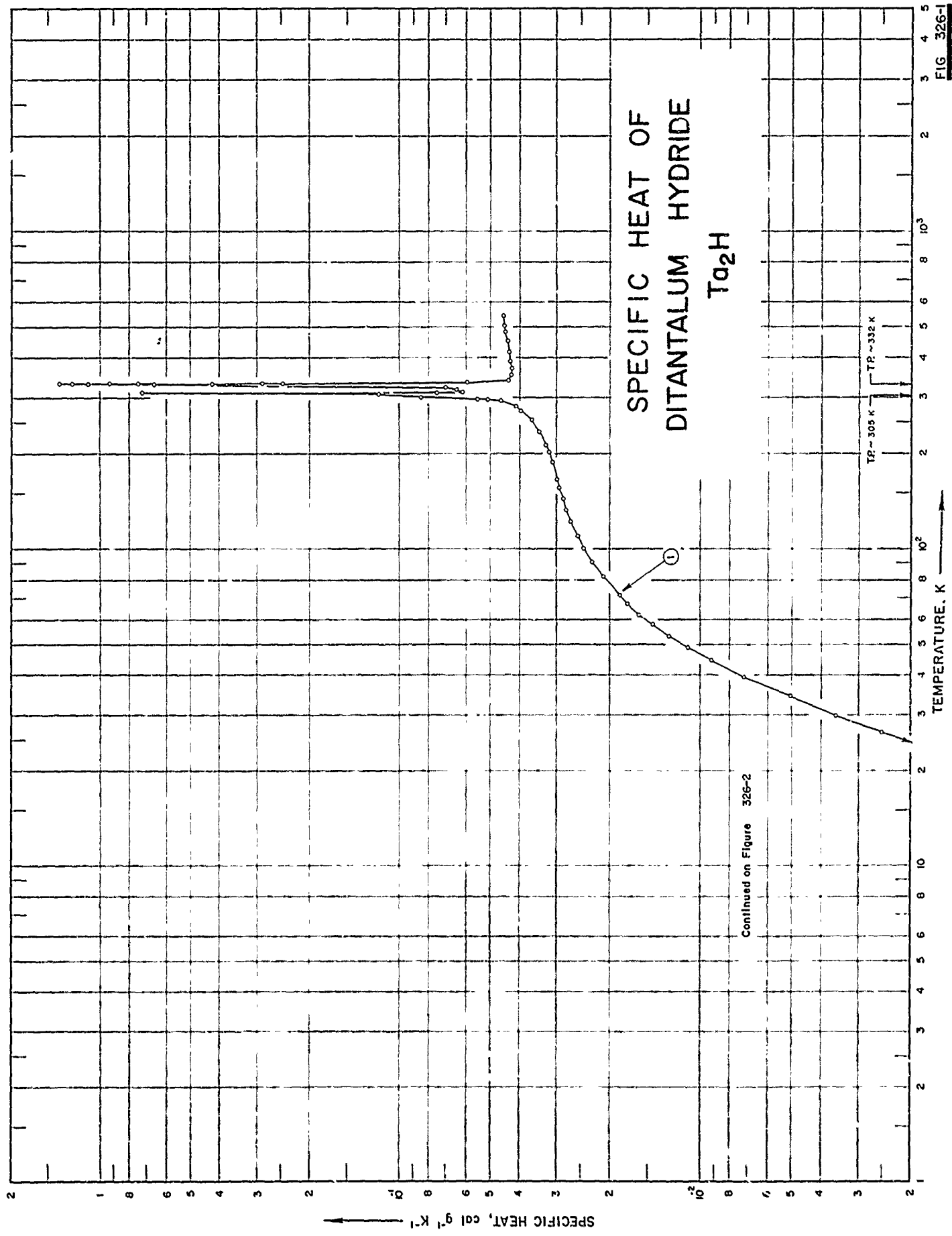
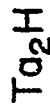
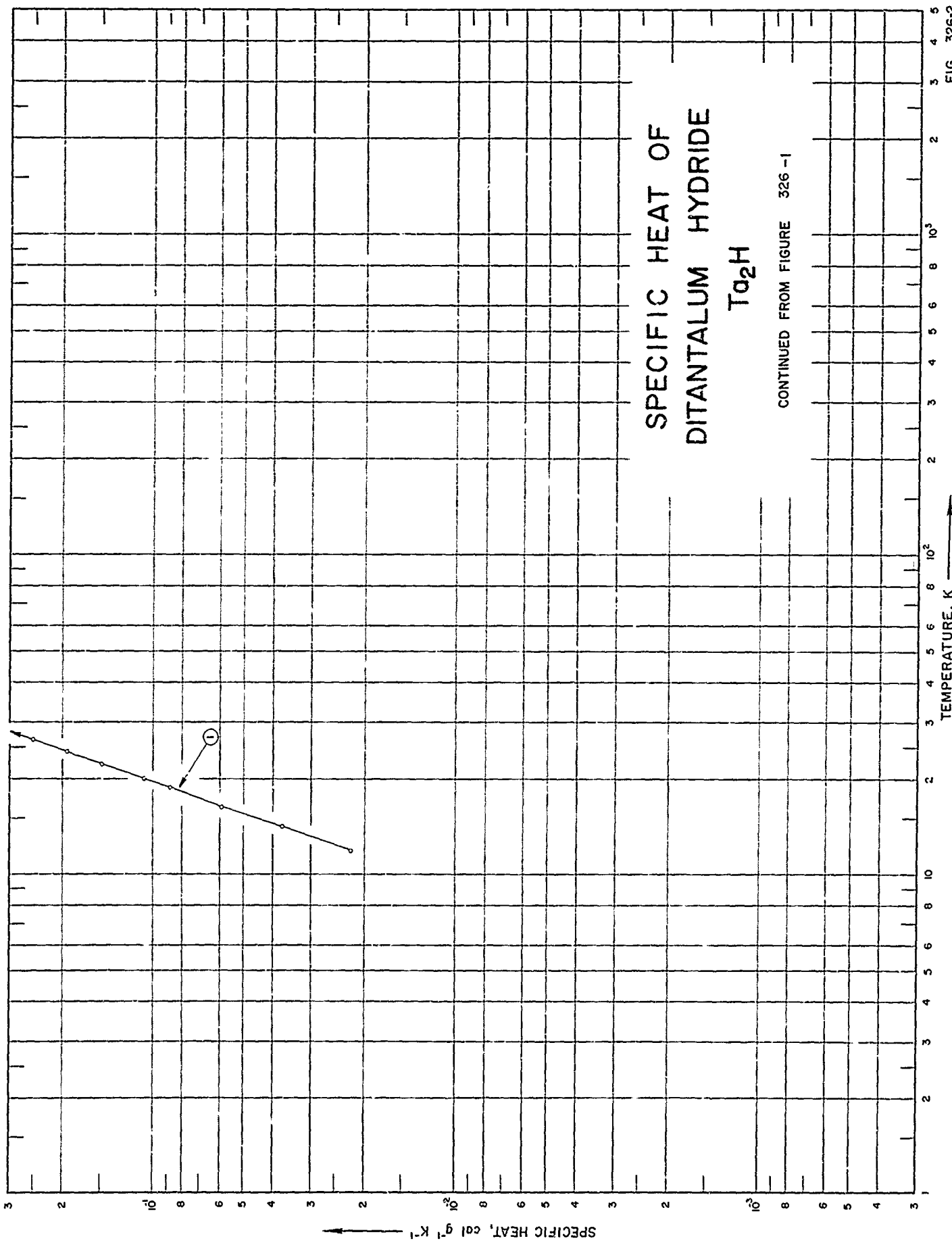

FIG 326-1

SPECIFIC HEAT OF DITANTALUM HYDRIDE



CONTINUED FROM FIGURE 326-1



SPECIFICATION TABLE NO. 326 SPECIFIC HEAT OF DITANTALUM HYDRIDE Ta_2H_2

[For Data Reported in Figure and Table No. 326]

Curve No.	Ref. No.	Year	Temp. Range, K	Reported Error, %	Name and Specimen Designation	Composition (weight percent), Specifications and Remarks
1	409	1961	12-552			Ta and H ₂ were supplied by the Fansteel Metallurgical Corp. and the Air Reduction Corp., respectively; prepared from annealed 99.9% Ta and 99.0% H ₂ .

DATA TABLE NO. 326 SPECIFIC HEAT OF DITANTALUM HYDRIDE Ta₂H(Temperature, T, K; Specific Heat, C_p, Cal g⁻¹K⁻¹)

T	C _p	T	C _p	T	C _p	T	C _p
71.91	1.878 x 10 ⁻²	296.86	5.142 x 10 ⁻²	284.20	4.252 x 10 ⁻²	334.36	1.271 x 10 ⁻¹
76.75	2.007*	300.29	7.452*	288.67	4.408	335.75	5.821 x 10 ⁻²
82.00	2.130	304.00	1.186 x 10 ⁻¹	293.01	4.665	347.44	4.315*
87.67	2.250*	307.03	1.165*	297.08	5.485	353.05	4.597*
91.45	2.314	310.90	6.925 x 10 ⁻²	300.58	7.799	359.09	3.905*
96.23	7.390*	315.76	6.326*	303.27	1.137 x 10 ⁻¹	265.55	4.305*
101.65	2.472	319.00	6.581	305.50	1.266	372.23	4.307
106.98	2.543*			307.75	1.109	379.07	4.313
110.90	2.593			310.62	6.856 x 10 ⁻²	385.74	4.316*
116.71	2.659*			314.10	6.202	392.39	4.324
122.37	2.716			317.64	6.463	399.04	4.335*
127.91	2.766*	200.48	3.211 x 10 ⁻²	321.07	6.799	405.07	4.344
133.36	2.813	207.60	3.254*	324.37	7.259	412.30	1.350*
138.72	2.856*	214.92	3.301			418.91	4.357
144.42	2.895	222.06	3.352*			425.53	1.371*
150.46	2.935*	228.83	3.404*			432.14	4.386
156.41	2.972	235.54	3.464			438.74	4.396*
162.76	3.007*	242.19	3.532			445.33	4.397*
169.53	3.043	248.73	3.605*	304.63	1.219 x 10 ⁻¹	451.90	4.406
176.23	3.078*	255.18	3.688	306.75	1.193*	458.47	4.423*
182.82	3.115*	261.52	3.777*	307.92	1.105*	465.00	4.454*
189.35	3.150	267.76	3.879*	308.91	9.066 x 10 ⁻²	471.57	4.444*
195.81	3.185*	273.95	3.998	309.83	7.361*	478.10	4.456
202.20	3.221	280.13	4.144*	310.87	6.414*	484.62	4.473
205.52	3.260*	286.30	4.326*	311.89	6.143	491.15	4.471
				312.84	6.136		
				313.80	6.171*		
				314.74	6.215*		
				315.74	6.215*		
				316.74	6.215*		
				317.74	6.215*		
				318.74	6.215*		
				319.74	6.215*		
				320.74	6.215*		
				321.74	6.215*		
				322.74	6.215*		
				323.74	6.215*		
				324.74	6.215*		
				325.74	6.215*		
				326.74	6.215*		
				327.74	6.215*		
				328.74	6.215*		
				329.74	6.215*		
				330.74	6.215*		
				331.74	6.215*		
				332.74	6.215*		
				333.74	6.215*		
				334.74	6.215*		
				335.74	6.215*		
				336.74	6.215*		
				337.74	6.215*		
				338.74	6.215*		
				339.74	6.215*		
				340.74	6.215*		
				341.74	6.215*		
				342.74	6.215*		
				343.74	6.215*		
				344.74	6.215*		
				345.74	6.215*		
				346.74	6.215*		
				347.74	6.215*		
				348.74	6.215*		
				349.74	6.215*		
				350.74	6.215*		
				351.74	6.215*		
				352.74	6.215*		
				353.74	6.215*		
				354.74	6.215*		
				355.74	6.215*		
				356.74	6.215*		
				357.74	6.215*		
				358.74	6.215*		
				359.74	6.215*		
				360.74	6.215*		
				361.74	6.215*		
				362.74	6.215*		
				363.74	6.215*		
				364.74	6.215*		
				365.74	6.215*		
				366.74	6.215*		
				367.74	6.215*		
				368.74	6.215*		
				369.74	6.215*		
				370.74	6.215*		
				371.74	6.215*		
				372.74	6.215*		
				373.74	6.215*		
				374.74	6.215*		
				375.74	6.215*		
				376.74	6.215*		
				377.74	6.215*		
				378.74	6.215*		
				379.74	6.215*		
				380.74	6.215*		
				381.74	6.215*		
				382.74	6.215*		
				383.74	6.215*		
				384.74	6.215*		
				385.74	6.215*		
				386.74	6.215*		
				387.74	6.215*		
				388.74	6.215*		
				389.74	6.215*		
				390.74	6.215*		
				391.74	6.215*		
				392.74	6.215*		
				393.74	6.215*		
				394.74	6.215*		
				395.74	6.215*		
				396.74	6.215*		
				397.74	6.215*		
				398.74	6.215*		
				399.74	6.215*		
				400.74	6.215*		
				401.74	6.215*		
				402.74	6.215*		
				403.74	6.215*		
				404.74	6.215*		
				405.74	6.215*		
				406.74	6.215*		
				407.74	6.215*		
				408.74	6.215*		
				409.74	6.215*		
				410.74	6.215*		
				411.74	6.215*		
				412.74	6.215*		
				413.74	6.215*		
				414.74	6.215*		
				415.74	6.215*		
				416.74	6.215*		
				417.74	6.215*		
				418.74	6.215*		
				419.74	6.215*		
				420.74	6.215*		
				421.74	6.215*		
				422.74	6.215*		
				423.74	6.215*		
				424.74	6.215*		
				425.74	6.215*		
				426.74	6.215*		
				427.74	6.215*		
				428.74	6.215*		
				429.74	6.215*		
				430.74	6.215*		
				431.74	6.215*		
				432.74	6.215*		
				433.74	6.215*		
				434.74	6.215*		
				435.74	6.215*		
				436.74	6.215*		
				437.74	6.215*		
				438.74	6.215*		
				439.74	6.215*		
				440.74	6.215*		
				441.74	6.215*		
				442.74	6.215*		
				443.74	6.215*		
				444.74	6.215*		
				445.74	6.215*		
				446.74	6.215*		
				447.74	6.215*		
				448.74	6.215*		
				449.74	6.215*		
				450.74	6.215*		
				451.74	6.215*		
				452.74	6.215*		
				453.74	6.215*		
				454.74	6.215*		
				455.74	6.215*		
				456.74	6.215*		
				457.74	6.215*		
				458.74	6.215*		
				459.74	6.215*		
				460.74	6.215*		
				461.74	6.215*		
				462.74	6.215*		
				463.74	6.215*		
				464.74	6.215*		
				465.74	6.215*		
				466.74	6.215*		
				467.74	6.215*		
				468.74	6.215*		
				469.74	6.215*		
				470.74	6.215*		
				471.74	6.215*		
				472.74			

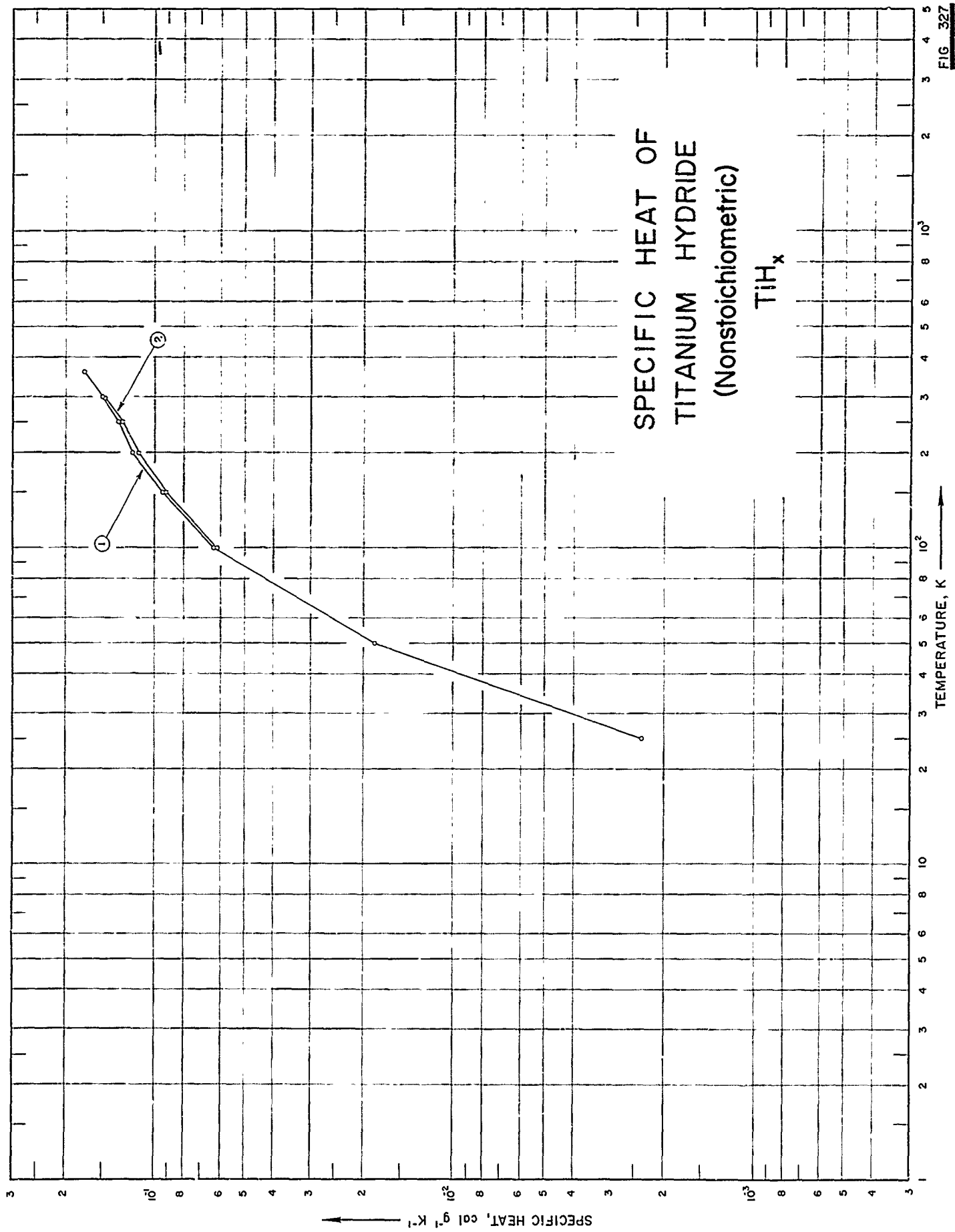

SPECIFICATION TABLE NO. 327 SPECIFIC HEAT OF TITANIUM HYDRIDE (nonstoichiometric) TiH_x

[For Data Reported in Figure and Table No. 327]

Curve No.	Ref. No.	Year	Temp. Range, K	Reported Error, %	Name and Specimen Designation	Composition (weight percent), Specifications and Remarks
1	410	1962	25-360			T.H.I. 607.
2	410	1962	100-360			T.H.I. 718.

DATA TABLE NO. 327 SPECIFIC HEAT OF TITANIUM HYDRIDE TH_x (nonstoichiometric)
 [Temperature, T, K; Specific Heat, C_p , Cal $g^{-1}K^{-1}$]

T	C_p
	<u>CURVE 1</u>
25	2.37×10^{-3}
50	1.84×10^{-2}
100	6.39
150	9.42
200	1.19×10^{-1}
250	1.34
298.15	1.50*
300	1.51
360	1.74
	<u>CURVE 2</u>
100	6.25×10^{-2}
150	9.19
200	1.13×10^{-1}
250	1.30
298.15	1.47
300	1.48*
360	1.72*

* Not shown on plot

SPECIFIC HEAT OF TITANIUM DIHYDRIDE TiH₂

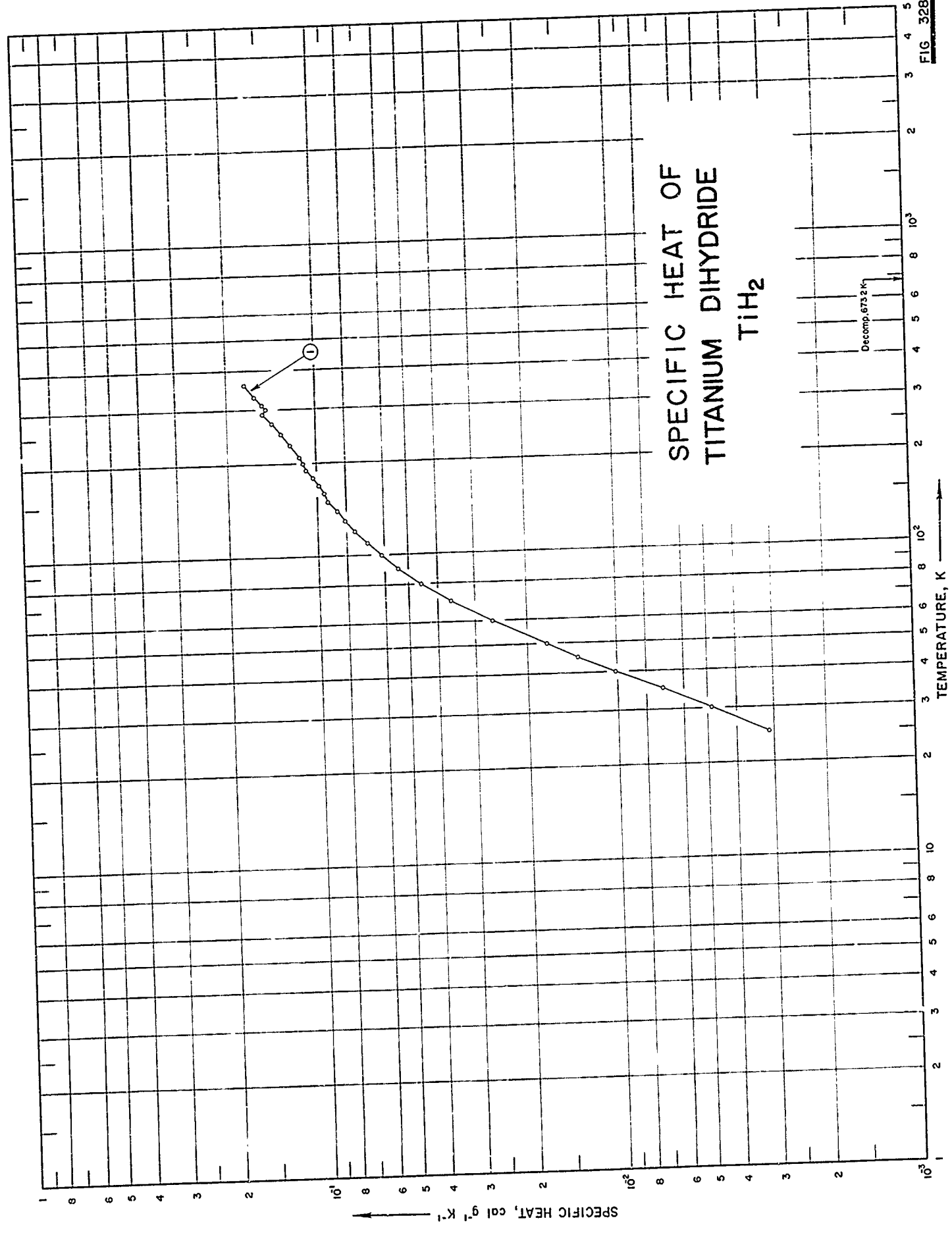

SPECIFIC HEAT, cal g⁻¹ K⁻¹

TEMPERATURE, K

SPECIFICATION TABLE NO. 328 SPECIFIC HEAT OF TITANIUM DIHYDRIDE TiH_2

[For Data Reported in Figure and Table No. 328]

Curve No.	Ref. No.	Year	Temp. Range, K	Reported Error, %	Name and Specimen Designation	Composition (weight percent), Specifications and Remarks
1	208	1960	25-360	1.0		>99.5 Ti; prepared by direct absorption of known volumes of hydrogen with >99.5 Ti.

DATA TABLE NO. 328 SPECIFIC HEAT OF TITANIUM DIHYDRIDE TiH_2 [Temperature, T, K; Specific Heat, C_p , Cal $\text{g}^{-1}\text{K}^{-1}$]

T	C_p
CURVE 1	
25	3.13×10^{-3}
30	4.85
35	7.05
40	1.01×10^{-2}
45	1.36
50	1.74
60	2.62
70	3.639
80	4.570
90	5.449
100	6.195
110	6.890
120	7.535
130	8.117
140	8.643
150	9.289
160	9.487
170	9.896
180	1.030×10^{-1}
190	1.090
200	1.110
210	1.151
220	1.191*
230	1.233
240	1.276*
250	1.319
260	1.364*
270	1.414
273.16	1.430*
280	1.470*
288.5	1.560*
290	1.522
298.16	1.470*
300	1.479
310	1.523
320	1.567*
330	1.611
340	1.656*
350	1.701*
360	1.745

* Not shown on plot

SPECIFIC HEAT OF
URANIUM TRIHYDRIDE
UH₃

FIG 329

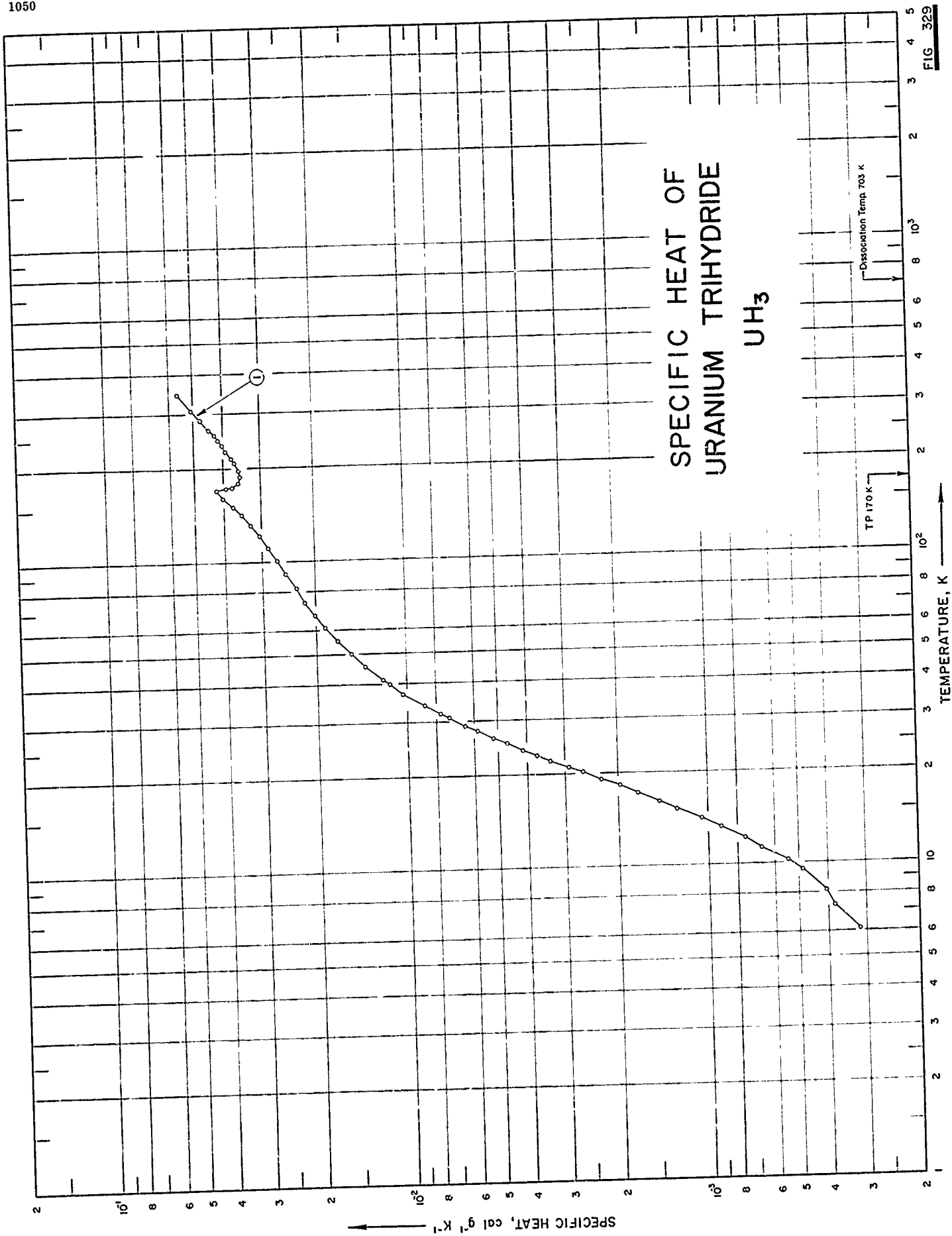

SPECIFICATION TABLE NO. 329 SPECIFIC HEAT OF URANIUM TRIHYDRIDE UH_3

[For Data Reported in Figure and Table No. 329]

Curve No.	Ref. No.	Year	Temp. Range, K	Reported Error, %	Name and Specimen Designation	Composition (weight percent), Specifications and Remarks
1	209	1959	6-347	< 5		99.6 UH_3 and 0.06 O_2 ; prepared by direct reaction of high purity uranium metal and hydrogen above 200 C.

DATA TABLE NO. 329 SPECIFIC HEAT OF URANIUM TRIHYDRIDE UH₃[Temperature, T, K; Specific Heat, C_p, Cal g⁻¹K⁻¹]

T	C _p	T	C _p	T	C _p
	<u>CURVE 1</u>		<u>CURVE 1 (cont.)</u>		<u>CURVE 1 (cont.)</u>
	Series I				
7.30	3.815 x 10 ⁻⁴	307.28	5.027 x 10 ⁻²	171.03	4.434 x 10 ⁻²
9.54	4.894	317.40	5.185*	171.57	4.359
11.38	6.637	327.14	5.334*	172.12	4.206
13.26	9.001	336.88	5.488*		Series V*
15.24	1.265 x 10 ⁻³	346.94	5.637		
17.22	1.717			187.86	3.525 x 10 ⁻²
19.13	2.277			189.92	3.526
21.04	2.937			191.98	3.536
23.05	3.725				Series VI*
25.32	4.691			168.23	4.326 x 10 ⁻²
27.95	5.890			168.77	4.351
30.86	7.250			169.31	4.376
34.03	8.748			169.85	4.417
37.61	1.037 x 10 ⁻²			170.39	4.438
41.57	1.206			170.92	4.451
45.84	1.373			171.46	4.359
50.56	1.542			172.00	4.227
55.62	1.701			172.55	4.101
61.30	1.865				
67.49	2.022				
74.65	2.180				
82.65	2.349				
91.26	2.514				
100.80	2.677				
111.19	2.863				
121.54	3.057				
131.94	3.266				
142.20	3.498				
151.18	3.729				
160.37	4.011				
170.23	4.222				
180.00	3.555				
189.80	3.524				
199.31	3.578				
209.17	3.663				
218.64	3.766				
228.00	3.875				
237.91	4.093				
246.03	4.141				
257.70	4.276				
267.36	4.417				
277.20	4.563*				
287.09	4.712				
297.06	4.865*				

T	C _p	T	C _p
	<u>CURVE 1 (cont.)</u>		<u>CURVE 1 (cont.)</u>
307.28	5.027 x 10 ⁻²	160.14	4.001 x 10 ^{-2*}
317.40	5.185*	162.09	4.072*
327.14	5.334*	164.01	4.146*
336.88	5.488*	165.91	4.222*
346.94	5.637	167.79	4.301*
		169.64	4.405*
		171.48	4.376*
		173.37	3.941
		175.34	3.710
		177.35	3.607*
		179.37	3.560*
		181.40	3.534*
		183.43	3.520*
		185.45	3.515*
			Series IV*
		168.95	4.376 x 10 ⁻²
		169.45	4.393
		169.96	4.426
		170.49	4.442

* Not shown on plot

SPECIFIC HEAT OF
VANADIUM HYDRIDE
(Nonstoichiometric)
VH_x

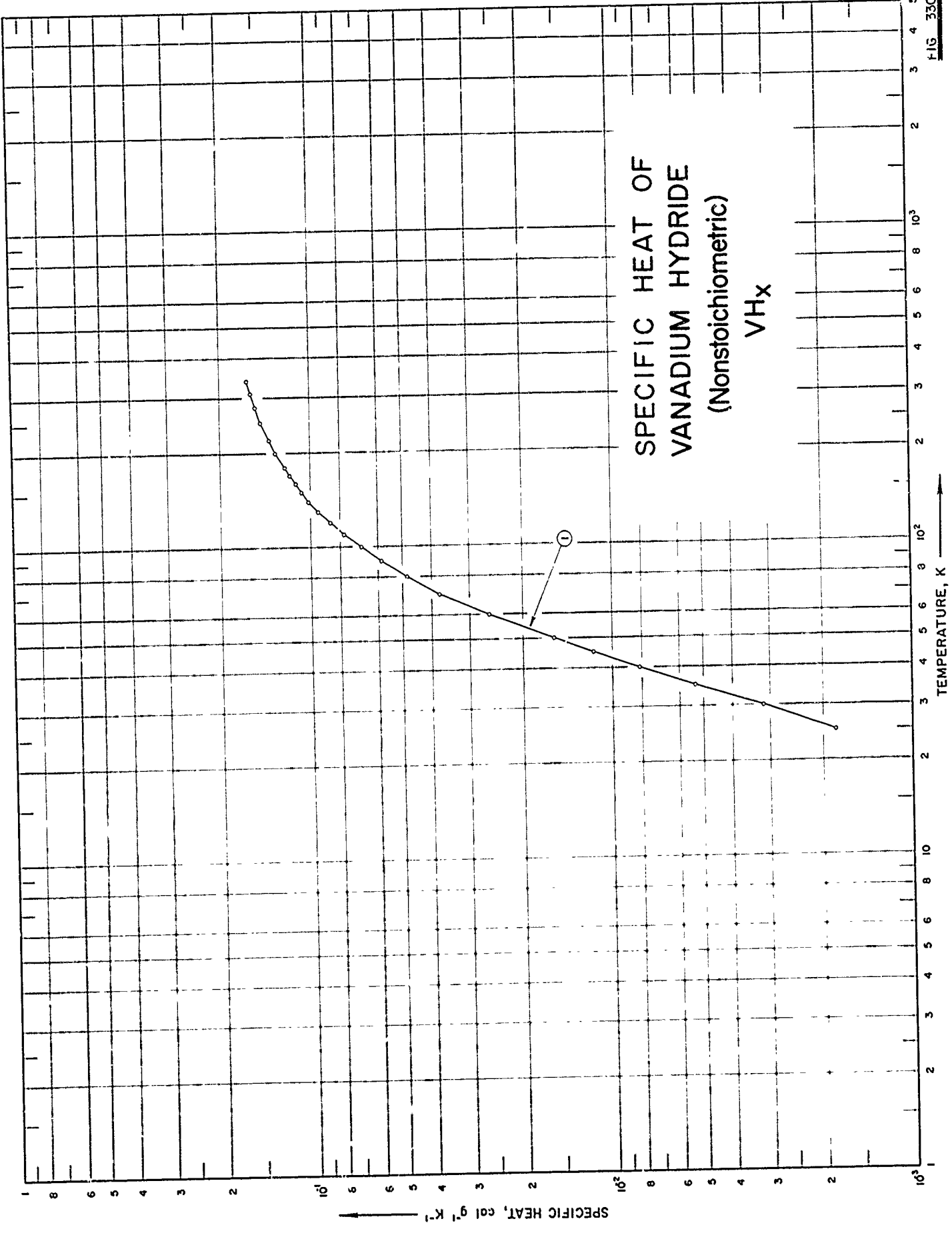

SPECIFICATION TABLE NO. 330 SPECIFIC HEAT OF VANADIUM HYDRIDE (nonstoichiometric) VH_x

[For Data Reported in Figure and Table No. 330]

Curve No.	Ref. No.	Year	Temp. Range, K	Reported Error, %	Name and Specimen Designation	Composition (weight percent), Specifications and Remarks
1	210	1961	25-340			$VH_{0.734}$; extra pure hydrogen was combined with 99.8 vanadium powder.

DATA TABLE NO. 330 SPECIFIC HEAT OF VANADIUM HYDRIDE VH_x (nonstoichiometric)
 [Temperature, T, K; Specific Heat, C_p , Cal $g^{-1}K^{-1}$]

T	C_p
	<u>CURVE 1</u>
25	1.8×10^{-3}
30	3.15
35	5.32
40	8.17
45	1.17×10^{-2}
50	1.58
60	2.597
70	3.773
80	4.837
90	5.882
100	6.869
110	7.817
120	8.669
130	9.462
140	1.018×10^{-1}
150	1.080
160	1.132
170	1.180
180	1.225
190	1.267*
200	1.308
210	1.345*
220	1.378
230	1.413*
240	1.440*
250	1.467
260	1.486*
270	1.507*
280	1.527
290	1.546*
298.16	1.556*
300	1.562*
310	1.579
320	1.592*
330	1.606*
340	1.620

* Not shown on plot

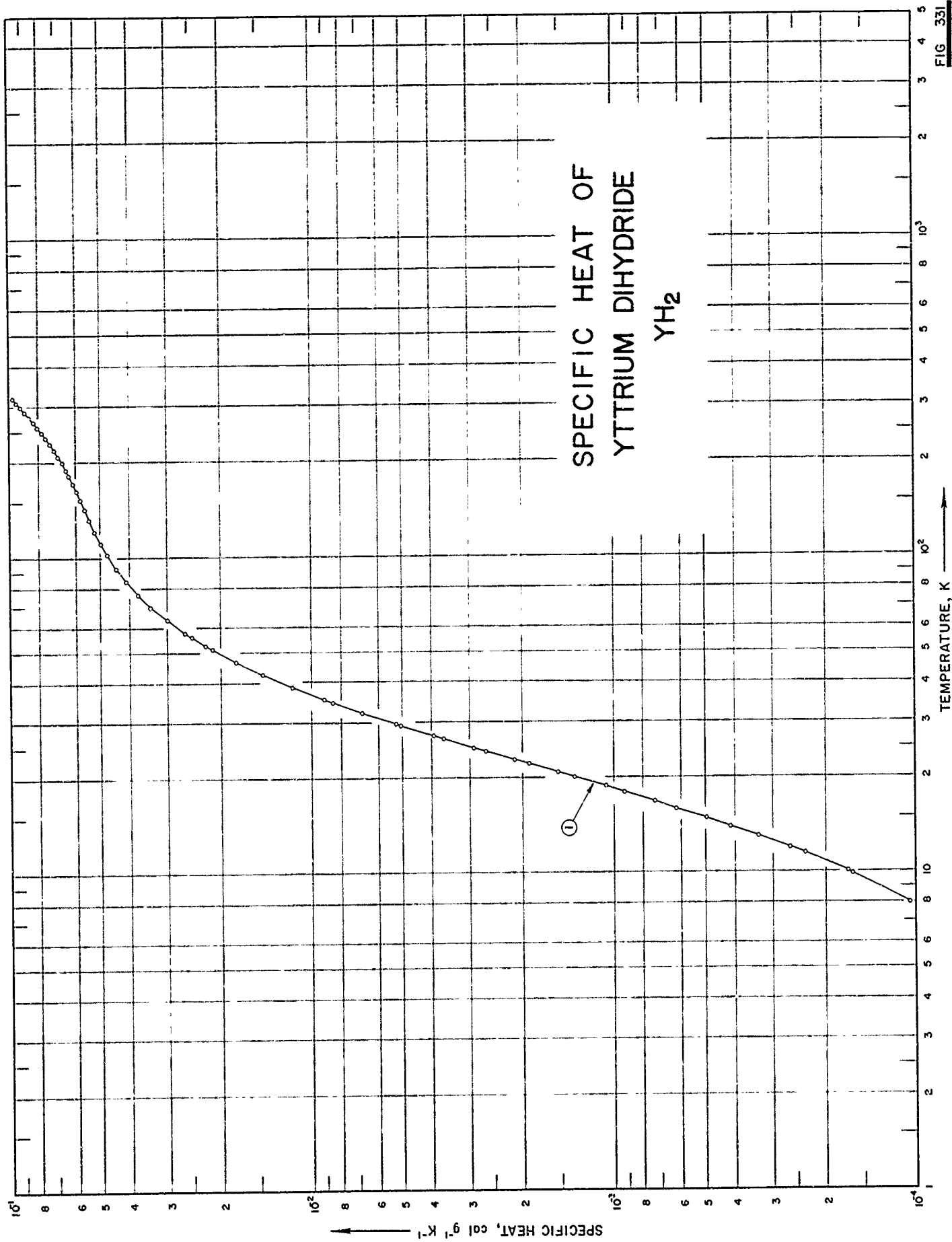

FIG. 331

SPECIFICATION TABLE NO. 331 SPECIFIC HEAT OF YTTRIUM DIHYDRIDE YH_2

[For Data Reported in Figure and Table No. 331]

Curve No.	Ref. No.	Year	Temp. Range, K	Reported Error, %	Name and Specimen Designation	Composition (weight percent), Specifications and Remarks
1	411	1962	6-347			H/Y = 2.003 ± 0.004; impurities: 0.0199 O ₂ , 0.0135 C, 0.0060 F ₂ , and 0.0017 N ₂ ; prepared by reacting purified Y with H ₂ at 400 C; specimen cooled to room temperature in vacuo.

DATA TABLE NO. 331 SPECIFIC HEAT OF YTTRIUM DIHYDRIDE YH_2
 [Temperature, T, K; Specific Heat, C_p , Cal $\text{g}^{-1}\text{K}^{-1}$]

T	C_p	T	C_p
CURVE I		CURVE I (cont.)	
Series I			
281.94	$8.619 \times 10^{-2*}$	39.06	1.161×10^{-2}
291.75	8.888*	42.99	1.457
301.53	9.168	47.02	1.780
311.97	9.449	51.50	2.128
322.20	9.733	56.46	2.493
332.50	$1.002 \times 10^{-1*}$	Series IV	
342.72	1.030*	53.07	2.245×10^{-2}
347.32	1.043*	58.23	2.622
Series II		64.03	3.009
6.00	$6.4 \times 10^{-5*}$	70.28	3.400
7.97	1.1×10^{-4}	77.19	3.757
9.89	1.63	84.81	4.118
11.51	2.34	93.11	4.437
13.04	3.34	102.06	4.723
14.85	4.96	111.72	4.987
16.79	7.32	122.02	5.231
18.79	1.07×10^{-3}	132.61	5.448
20.83	1.537	143.18	5.639
22.84	2.130	153.52	5.817
24.97	2.918	163.68	5.987
27.26	3.941	173.83	6.159
29.76	5.262	183.90	6.337
32.32	6.823	Series V	
34.85	8.519	181.38	$6.291 \times 10^{-2*}$
Series III		191.00	6.467
5.88	$6.2 \times 10^{-5*}$	200.85	6.657
7.97	$1.1 \times 10^{-4*}$	210.94	6.862
10.03	1.69	221.07	7.084
11.99	2.64	231.14	7.313
13.98	4.12	241.22	7.554
15.98	6.25	251.32	7.805
18.00	9.23	261.41	8.068
20.10	1.354×10^{-3}	271.47	8.335
22.14	1.905	281.54	8.607
24.30	2.651	291.68	8.888
26.68	3.662		
29.42	5.065		
32.49	6.932*		
35.64	9.076		

* Not shown on plot

FIG 332

SPECIFIC HEAT OF YTTRIUM TRIHYDRIDE YH₃

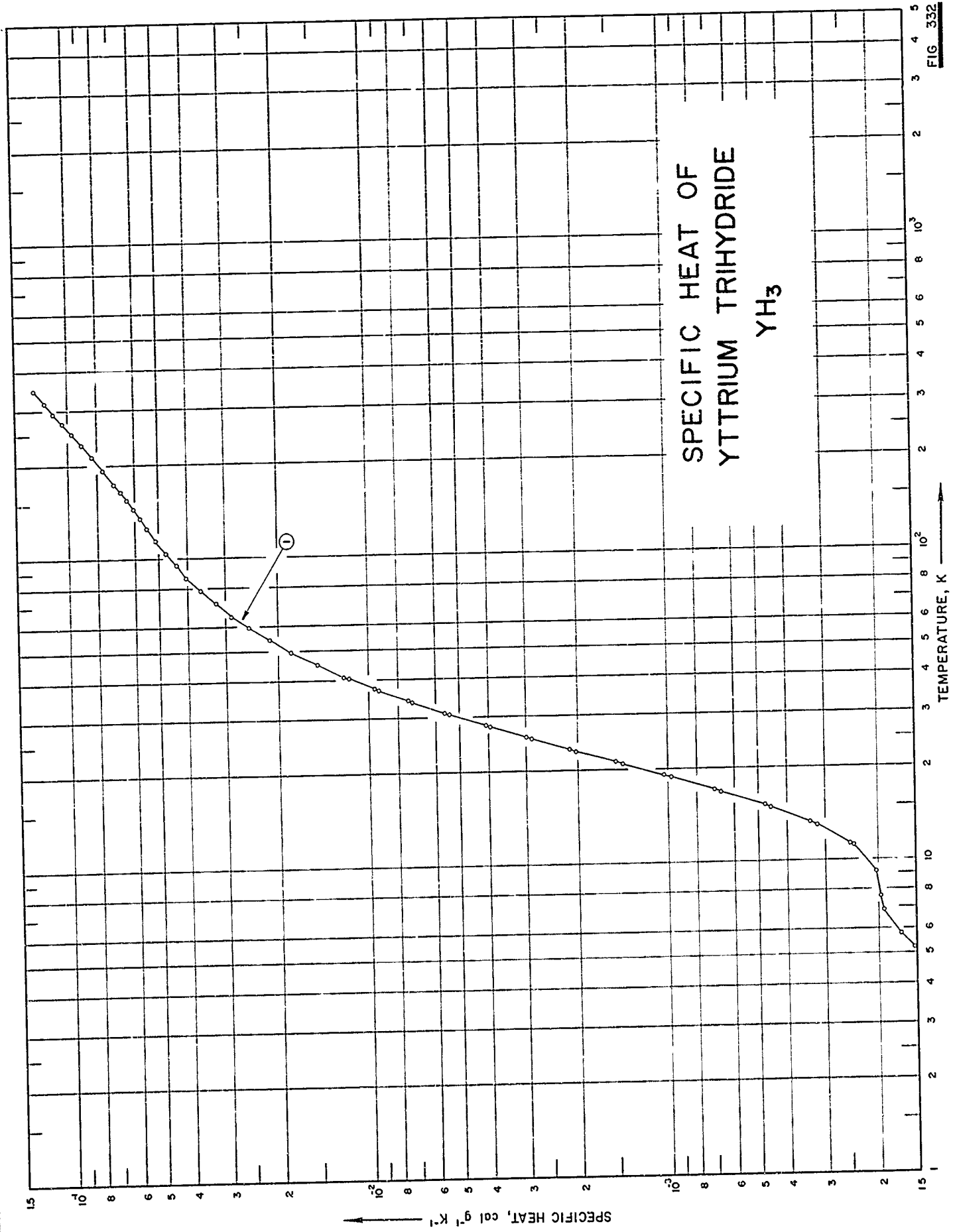

SPECIFICATION TABLE NO. 332 SPECIFIC HEAT OF YTTRIUM TRIHYDRIDE YH_3

[For Data Reported in Figure and Table No. 332]

Curve No.	Ref. No.	Year	Temp. Range, K	Reported Error, %	Name and Specimen Designation	Composition (weight percent), Specifications and Remarks
1	211	1963	5-346	<1		0.1 impurities; prepared by the reaction of YH_2 and H_2 at 350 C and 350 mm Hg for 48 hrs; cooled to room temperature over a 4 hr period with hydrogen pressure of 400 mm Hg.

SPECIFIC HEAT OF YTTRIUM DIDEUTERIDE YD_2

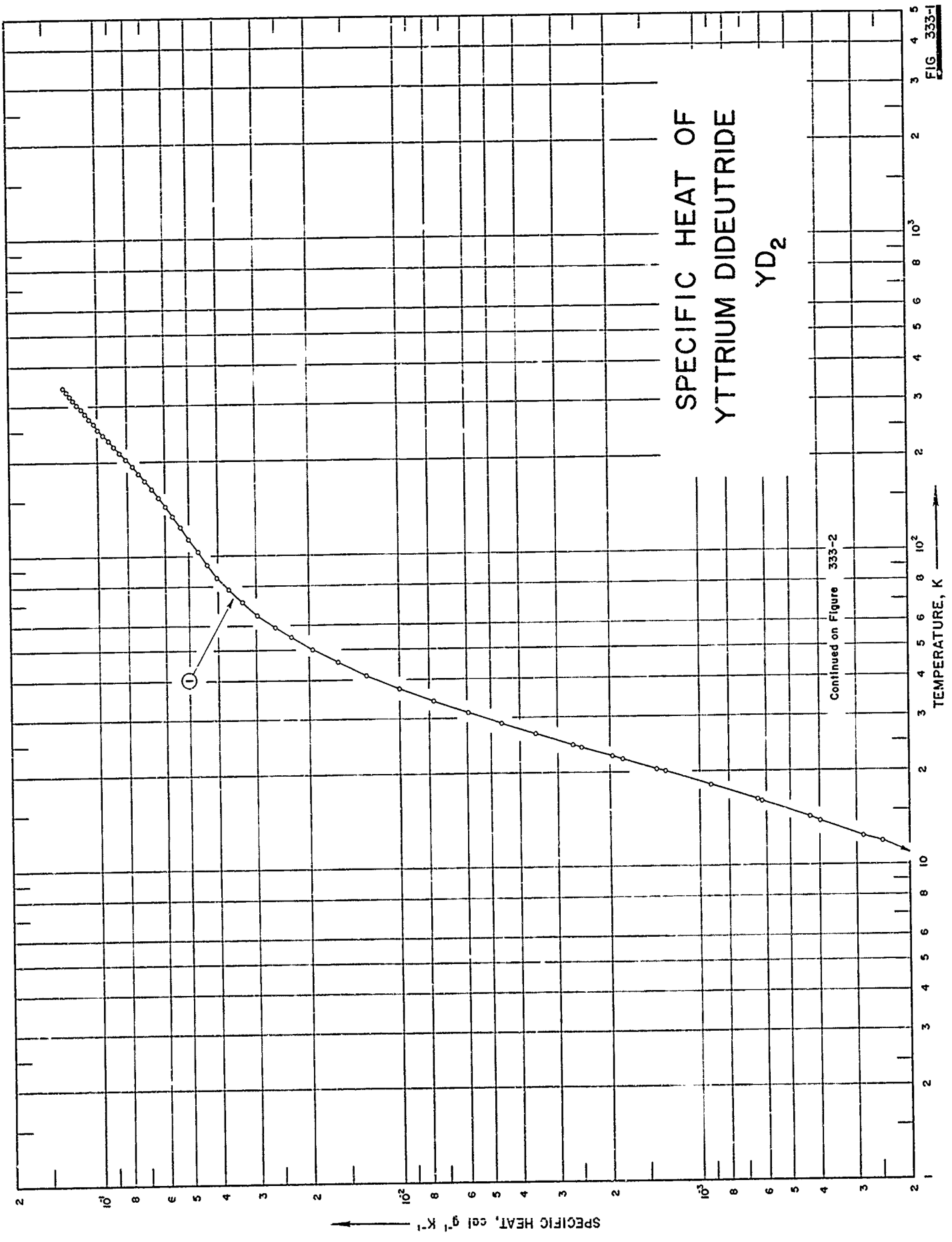

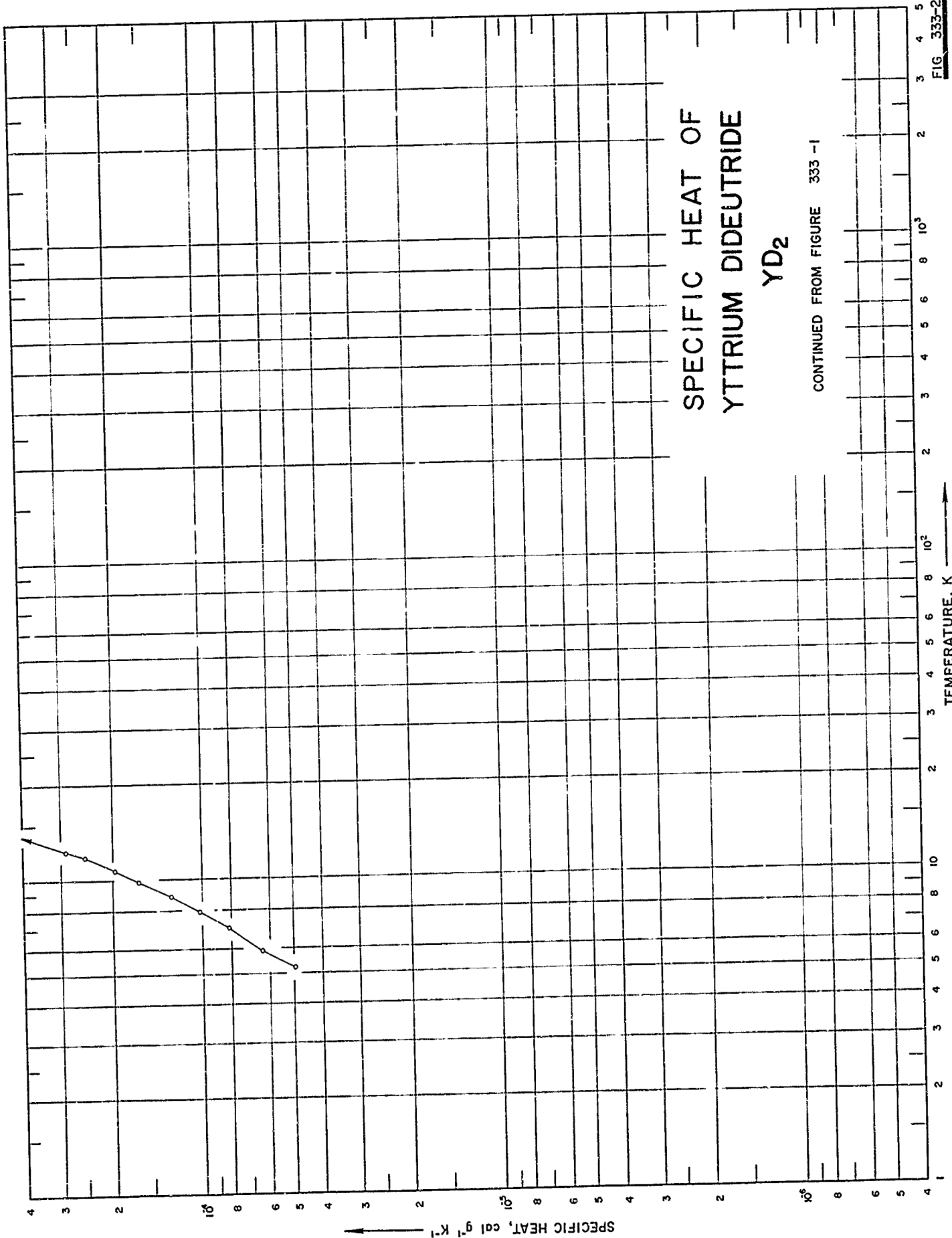

SPECIFICATION TABLE NO. 333 SPECIFIC HEAT OF YTTRIUM DIDEUTERIDE YD_2

[For Data Reported in Figure and Table No. 333]

Curve No.	Ref. No.	Year	Temp. Range, K	Reported Error, %	Name and Specimen Designation	Composition (weight percent), Specifications and Remarks
1	411	1962	5-344			D/Y = 2.003 ± 0.004 ; impurities: 0.0138 F ₂ , 0.0135 C, 0.0125 O ₂ , and 0.0022 N ₂ ; prepared by reacting yttrium metal with purified deuterium at 400 C.

DATA TABLE NO. 333 SPECIFIC HEAT OF YTTRIUM DIDEUTERIDE YD₂[Temperature, T, K; Specific Heat, C_p, Cal g⁻¹K⁻¹]

T	C _p	T	C _p
CURVE I			
Sc. 651			
5.91	6.3 × 10 ⁻⁵	78.23	3.708 × 10 ⁻²
7.94	1.0 × 10 ⁻⁴	85.74	4.057
9.88	1.63	93.96	4.377
11.83	2.46	103.01	4.687
13.87	3.98	113.48	5.022
16.06	6.21	124.47	5.360
18.12	9.18	134.82	5.680
20.06	1.306 × 10 ⁻³	144.92	5.998
22.03	1.817	154.81	6.323
24.09	2.488	164.58	6.657
28.63	4.470*	174.33	7.000
31.57	6.119*	184.11	7.361
34.67	8.098*	193.88	7.726
37.84	1.031*		
Series II			
5.22	4.9 × 10 ⁻⁵	194.78	7.761 × 10 ⁻² *
7.03	8.2	204.38	8.127
8.89	1.27 × 10 ⁻⁴	213.91	8.493
10.75	1.96	223.61	8.866
12.47	2.86	233.60	9.249
14.27	4.30	243.72	9.636
16.25	6.43	253.85	1.002 × 10 ⁻¹
18.25	9.42*	263.77	1.038
20.41	1.390 × 10 ⁻³	273.59	1.074
22.53	1.965	283.56	1.109
24.57	2.664	293.61	1.144
26.68	3.533	303.70	1.177
28.85	4.583	313.83	1.210
31.26	5.933	322.96	1.241
34.10	7.715	334.18	1.272
37.45	1.003 × 10 ⁻²	344.44	1.302
41.37	1.291		
45.63	1.615		
50.16	1.958		
55.00	2.311		
Series III			
54.18	2.254 × 10 ⁻² *		
59.28	2.614		
64.99	2.985		
71.30	3.349		

* Not shown on plot

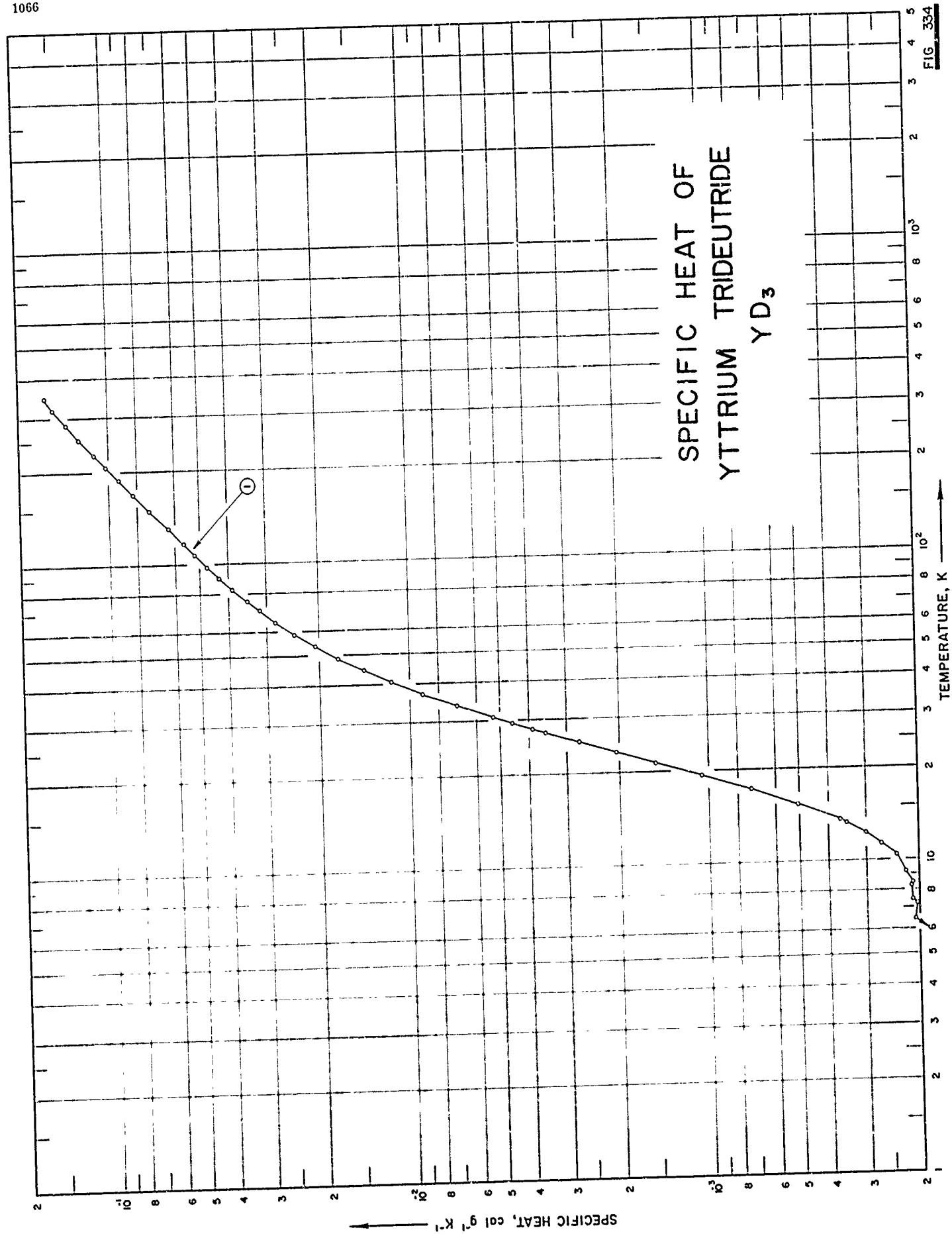

SPECIFICATION TABLE NO. 334 SPECIFIC HEAT OF YTTRIUM TRIDEUTERIDE YD_3

[For Data Reported in Figure and Table No. 334]

Curve No.	Ref. No.	Year	Temp. Range, K	Reported Error, %	Name and Specimen Designation	Composition (weight percent), Specifications and Remarks
1	211	1963	5-348	<1		0.1 impurities; prepared by reaction of YD_2 and deuterium gas.

DATA TABLE NO. 334 SPECIFIC HEAT OF YTTRIUM TRIDEUTERIDE YD₃[Temperature, T, K; Specific Heat, C_p, Cal g⁻¹K⁻¹]

T	C _p	T	C _p	T	C _p
<u>CURVE I</u>					
<u>Series I</u>					
5.26	1.71 x 10 ^{-4*}	54.02	2.109 x 10 ^{-2*}	328.84	1.5663 x 10 ^{-1*}
6.42	2.07	58.73	2.440 [*]	338.80	1.6056 [*]
7.45	2.12	64.07	2.800	346.30	1.6322
8.47	2.11	70.22	3.189	<u>Series VIII[*]</u>	
10.45	2.37	<u>Series IV</u>			
11.32	2.66	75.21	3.490 x 10 ⁻²	51.67	1.944 x 10 ⁻²
12.25	2.99	82.25	3.907	56.15	2.269
13.59	3.05	89.67	4.318	60.61	2.567
15.33	5.95	97.95	4.742	66.19	2.938
17.22	7.28	107.23	5.207	72.46	3.325
19.22	1.057 x 10 ⁻³	116.93	5.690	79.02	3.710
21.20	1.593	<u>Series V</u>			
23.12	2.047	121.26	5.905 x 10 ^{-2*}	86.14	4.127
25.04	2.715	130.86	6.380	94.13	4.547
27.04	3.531	140.41	6.853 [*]	103.12	4.999
29.27	4.569	149.83	7.323	112.53	5.471
<u>Series II</u>					
5.15	1.60 x 10 ^{-4*}	159.30	7.794 [*]	121.91	5.935
6.24	1.96 [*]	168.94	8.261	<u>Series IX[*]</u>	
7.23	2.03	178.43	8.756 [*]	129.78	6.324 x 10 ⁻²
8.28	2.14	188.05	9.252	139.32	6.799
9.18	2.23	197.74	9.731 [*]	148.83	7.273
10.15	2.34 [*]	207.42	1.023 x 10 ⁻¹	158.48	7.751
11.50	2.67 [*]	217.11	1.0709 [*]	168.16	8.240
13.31	3.48	226.79	1.1187	177.83	8.733
15.22	4.97 [*]	<u>Series VI</u>			
17.22	7.25 [*]	235.31	1.1607 x 10 ^{-1*}	187.24	1.026 x 10 ⁻¹
19.20	1.05 x 10 ^{-2*}	245.12	1.2075 [*]	197.18	9.711 x 10 ⁻²
21.16	1.494 [*]	254.85	1.2536	207.15	1.021 x 10 ⁻¹
23.20	2.075 [*]	264.65	1.2987 [*]	216.97	1.0700
25.41	2.857 [*]	274.55	1.3440 [*]	226.90	1.1192
27.86	3.900	284.43	1.3871	236.77	1.1674
30.55	5.235	<u>Series VII</u>			
33.52	6.930	289.34	1.4082 x 10 ^{-1*}	246.54	1.2144
36.87	9.042	299.26	1.4496 [*]	256.39	1.2604
40.52	1.151 x 10 ⁻²	309.11	1.4902 [*]	266.32	1.3066
44.48	1.428	318.95	1.5290	286.23	1.3937
48.84	1.742	<u>Series X[*]</u>			
53.56	2.078	292.25	1.4209 x 10 ⁻¹	292.25	1.4209 x 10 ⁻¹
58.65	2.433	302.23	1.4625	302.23	1.4625
		312.15	1.5033	312.15	1.5033
		322.11	1.5421	322.11	1.5421
		332.04	1.5800	332.04	1.5800
		341.42	1.6142	341.42	1.6142
		348.00	1.6376	348.00	1.6376

* Not shown on plot

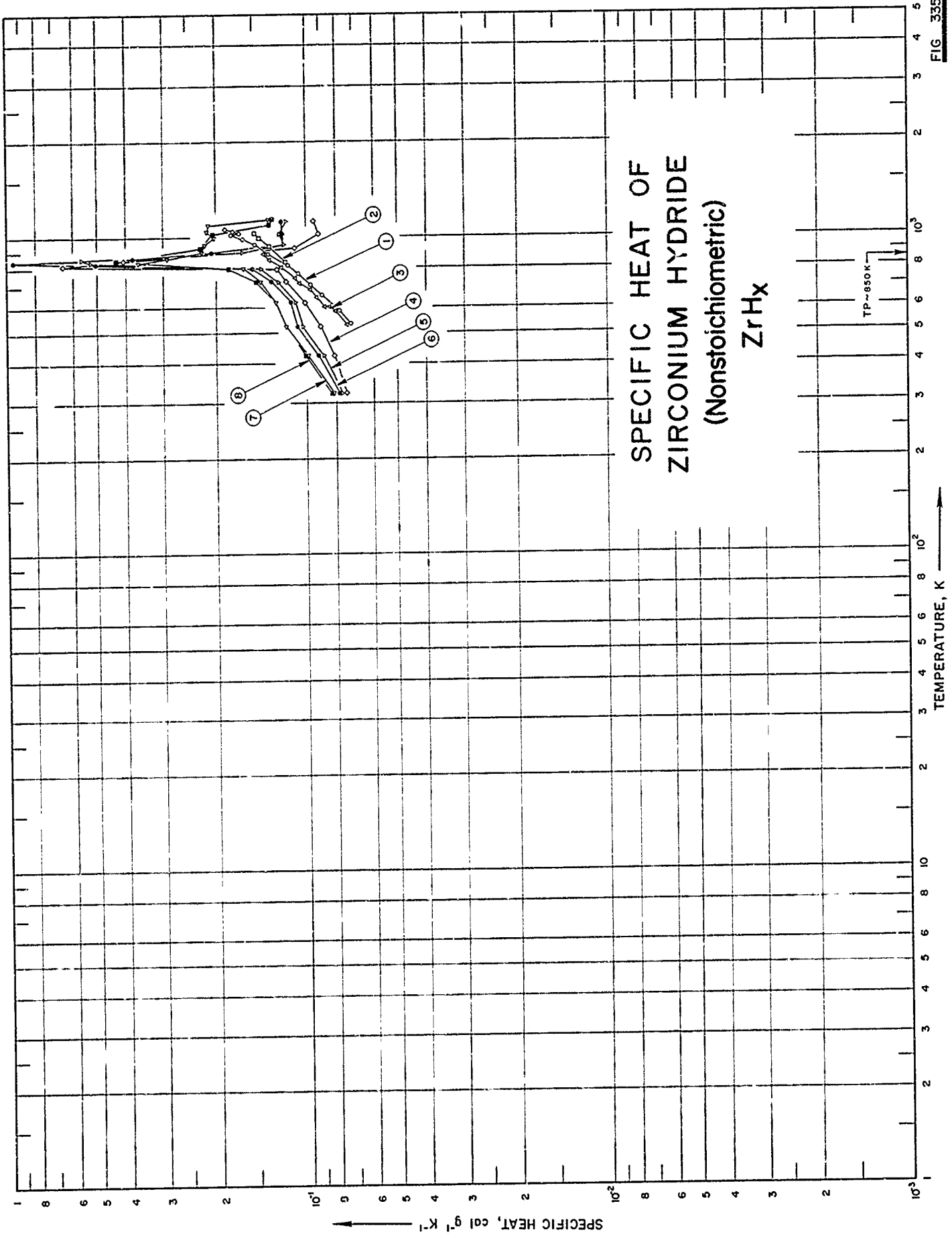

SPECIFICATION TABLE NO. 335 SPECIFIC HEAT OF ZIRCONIUM HYDRIDE (nonstoichiometric) ZrH_x

[For Data Reported in Figure and Table No. 335]

Curve No.	Ref. No.	Year	Temp. Range, K	Reported Error, %	Name and Specimen Designation	Composition (weight percent). Specifications and Remarks
1	212	1962	533-1063		50.2 At % H	$ZrH_{1.065}$: 99.10 Zr and 1.90 H.
2	212	1962	543-1038		57.1 At % H	$ZrH_{1.33}$: 98.55 Zr and 1.45 H.
3	212	1962	528-887		64.0 At % H	$ZrH_{1.18}$: 98.08 Zr, 1.92 H.
4	412	1957	323-1123			$ZrH_{0.34}$: 0.356 H, 0.1 Fe, 0.06 C, and 0.01 each Al, Cr, Hf, Mn, N, and O (corrected for impurities).
5	412	1957	323-1123			$ZrH_{0.556}$: 0.88 Fe, 0.611 H, 0.6 Hf, 0.48 Si, 0.32 C, 0.12 Al, and 0.1 Cr (corrected for impurities).
6	412	1957	323-1123			$ZrH_{0.701}$: 0.769 H, 0.53 Fe, 0.44 Hf, 0.35 Si, 0.32 C, 0.12 Al, 0.08 Ni, and 0.06 Cr (corrected for impurities).
7	412	1957	323-1148			$ZrH_{0.999}$: 1.092 H, 0.48 Hf, 0.41 Fe, 0.34 Si, 0.32 C, and 0.17 Al (corrected for impurities).
8	412	1957	323-1148			$ZrH_{1.071}$: 1.17 H, 0.1 Fe, 0.06 C, 0.017 O, and 0.01 each Al, Cr, Hf, Mn, and N.

DATA TABLE NO. 335 SPECIFIC HEAT OF ZIRCONIUM HYDRIDE ZrH_x (nonstoichiometric)
 [Temperature, T, K; Specific Heat, C_p , Cal $g^{-1}K^{-1}$]

T	C_p	T	C_p	T	C_p
<u>CURVE 1</u>					
533	7.126×10^2	323	7.38×10^2	323	8.15×10^2
588	7.783	423	8.12	423	9.85
659	8.880	523	8.99	523	1.169×10^{-1}
708	9.647	623	1.013×10^{-1}	623	1.261
768	1.063×10^{-1}	723	1.174	723	1.419
818	1.151	793	1.255	798	1.614
853	1.239^*	818	6.48	835	3.62
888	1.348	848	4.08	860	2.9
928	1.447^*	923	1.096	898	2.228
948	1.480	1023	9.09×10^2	948	2.176
978	1.590^*	1123	9.45	998	2.022
987	1.622			1048	2.150
1013	1.644^*	<u>CURVE 5</u>			
1023	1.677	323	7.62×10^2	1098	2.112
1048	1.754	423	8.80	1148	1.34
1018	1.787	523	1.028×10^{-1}	<u>CURVE 8</u>	
1063	1.864	623	1.087	323	8.23×10^2
<u>CURVE 2</u>					
543	7.235×10^2	423	1.244	423	1.006×10^{-1}
648	8.770	723	1.402	523	1.170
708	9.866	798	5.22	623	1.273
763	1.041×10^{-1}	835	5.6	723	1.466
838	1.173	860	1.63	798	1.808
938	1.337	898	1.194	848	4.30
993	1.447	1023	1.233	923	2.252
1038	1.491	1123	1.165	1023	2.050
<u>CURVE 3</u>					
528	7.345×10^2	323	7.80×10^2	1008	1.330
583	8.003	423	9.13	1148	1.30
603	8.441	523	1.078×10^{-1}		
603	8.715	623	1.126		
648	9.263	723	1.302		
683	9.702	798	1.510		
713	1.052×10^{-1}	828	5.0		
743	1.096	840	9.45		
803	1.211	860	3.78		
848	1.325	898	2.06		
887	1.392	948	1.188		
		1023	1.203		
		1123	1.21		

* Not shown on plot

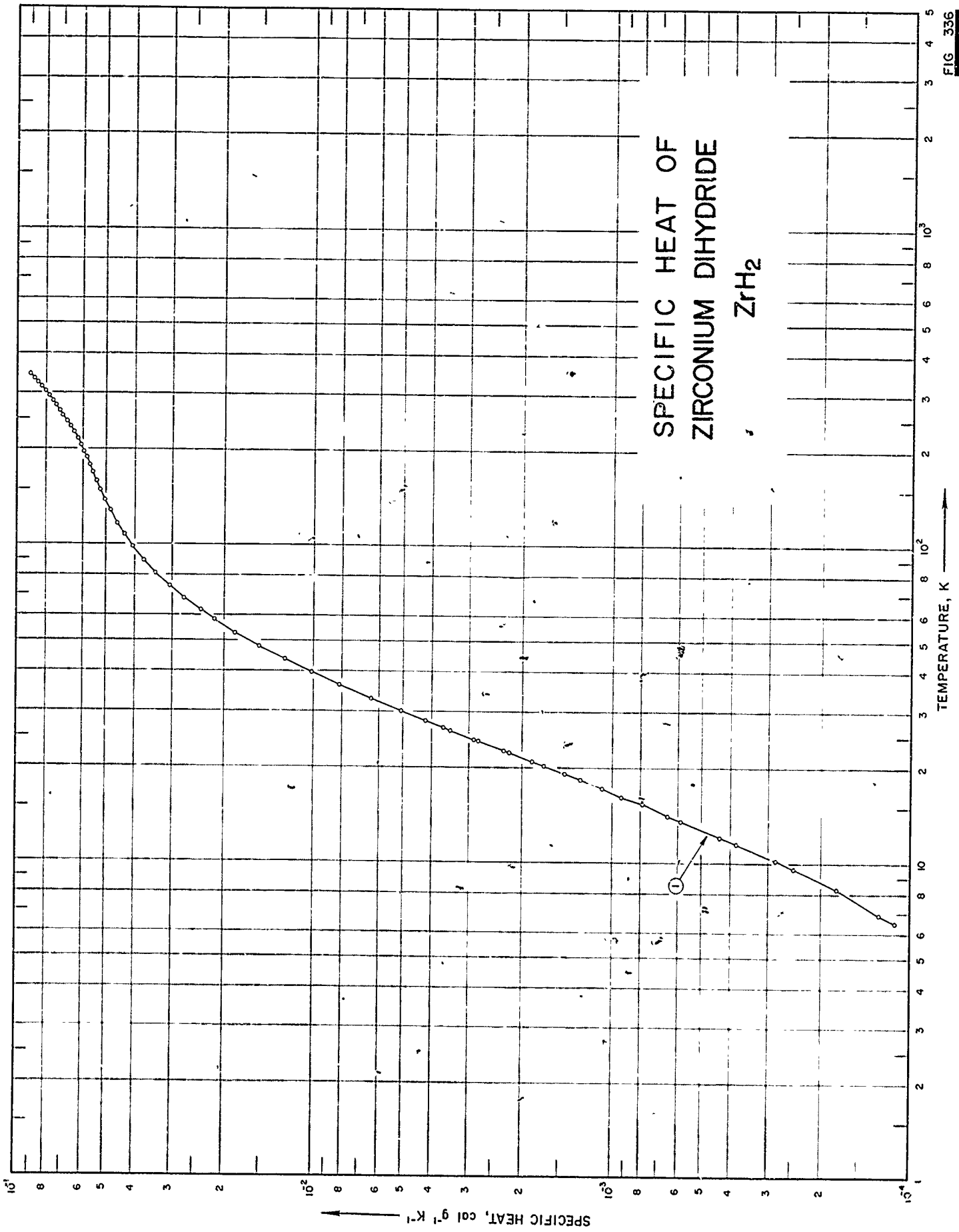

FIG 336

SPECIFICATION TABLE NO. 336 SPECIFIC HEAT OF ZIRCONIUM DIHYDRIDE ZrH_2

[For Data Reported in Figure and Table No. 336]

Curve No.	Ref. No.	Year	Temp. Range, K	Reported Error, %	Name and Specimen Designation	Composition (weight percent), Specifications and Remarks
1	413	1961	7-345			0.02 Fe, 0.01 Cu, 0.0015 Al, 0.0004 each Cr and Ni, 0.0002 Pb, 0.00002 Ag, and 0.00001 B; prepared on a high vacuum line by direct reaction of zirconium metal with hydrogen at about 400 C.

DATA TABLE NO. 336 SPECIFIC HEAT OF ZIRCONIUM DIHYDRIDE ZrH_2 [Temperature, T, K; Specific Heat, C_p , Cal $g^{-1}K^{-1}$]

T	C_p	T	C_p
<u>CURVE I</u>		<u>CURVE I (cont.)</u>	
Series I		Series IV	
6.87	1.26×10^{-4}	89.50	3.756×10^{-2} *
9.60	2.47	98.52	4.078
11.54	3.84	107.49	4.359
13.64	5.38	117.18	4.620
15.30	7.94	127.61	4.867
17.20	1.079×10^{-3}	138.07	5.077
19.12	1.446	148.30	5.261
20.96	1.864	158.34	5.421
22.63	2.312	168.19	5.571
24.48	2.898	178.09	5.713
26.65	3.672	188.08	5.858
Series II			
6.51	1.13×10^{-4}	186.63	5.840×10^{-2} *
8.34	1.77	196.67	5.988
10.23	2.83	206.59	6.140
12.14	4.35	216.40	6.296
14.17	6.53	226.27	6.459
16.22	9.32	236.14	6.631
18.26	1.276×10^{-3}	245.92	6.817
20.24	1.697	255.66	7.009
22.25	2.209	265.42	7.209
24.25	2.816	275.27	7.421
26.17	3.483	285.24	7.638
28.09	4.221	295.39	7.868
30.10	5.078	305.52	8.083
32.90	6.422	315.61	8.346
39.76	8.197	325.79	8.593
43.63	1.020×10^{-2}	335.94	8.837
47.99	1.523	345.42	9.084
52.99	1.840		
58.27	2.166		
Series III			
57.30	2.107×10^{-2} *		
62.42	2.396		
67.98	2.733		
74.12	3.052		
81.24	3.402		
89.14	3.742		

* Not shown on plot

FIG. 357

SPECIFIC HEAT OF ALUMINUM NITRIDE AlN

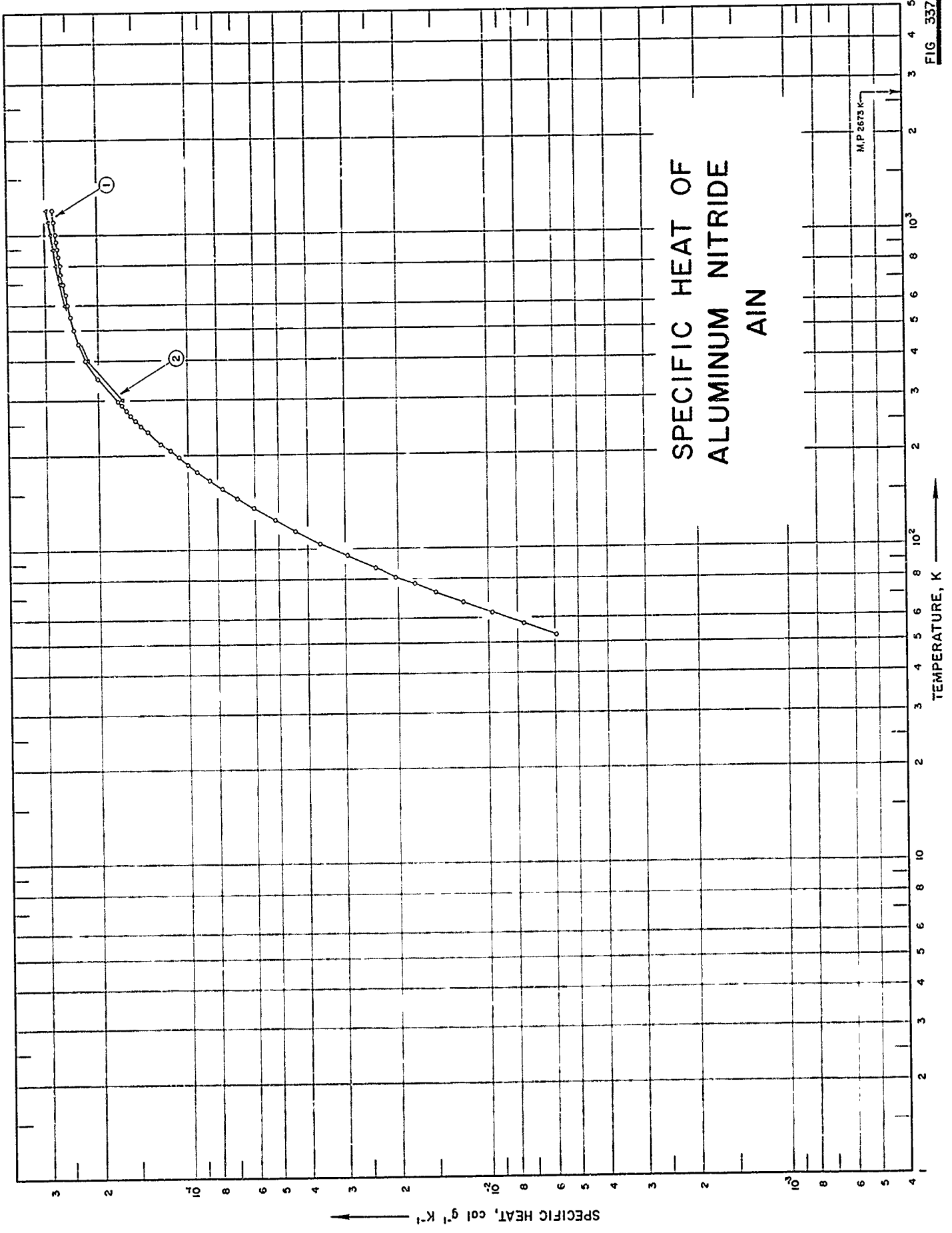

SPECIFICATION TABLE NO. 337 SPECIFIC HEAT OF ALUMINUM NITRIDE AlN

[For Data Reported in Figure and Table No. 337]

Curve No.	Ref. No.	Year	Temp. Range, K	Reported Error, %	Name and Specimen Designation	Composition (weight percent), Specifications and Remarks
1	213	1961	53-1200	0.3-0.9		98.92 AlN; 1.08 Al ₂ O ₃ . 0.01-0.05 Fe, 0.01 Si, <0.001 Ca, Mg, Cu, and <0.0001 Cf.
2	54	1965	300-1200	0.5		99.999 AlN; traces of Cu, Mg and Si; sample supplied by the Aluminum Co. of America.

DATA TABLE NO. 337 SPECIFIC HEAT OF ALUMINUM NITRIDE AlN

[Temperature, T, K; Specific Heat, C_p , Cal $g^{-1}K^{-1}$]

T	C_p	T	C_p
	<u>CURVE 1</u>		<u>CURVE 1 (cont.)</u>
52.91	5.980×10^{-3}	1050.00	$2.805 \times 10^{-1*}$
57.44	7.683	1100.00	2.821
62.13	9.783	1150.00	2.837
67.15	1.223×10^{-2}	1200.00	2.852
72.49	1.509		<u>CURVE 2</u>
77.19	1.786	300	1.696×10^{-1}
81.59	2.057	400	2.183
86.79	2.391	500	2.435*
95.03	2.962	600	2.584
104.95	3.681	700	2.689
114.74	4.421	800	2.769
124.54	5.191	900	2.835
135.81	6.102	1000	2.891
145.91	6.941	1100	2.945
156.30	7.802	1200	2.994
165.80	8.573		
176.29	9.417		
185.94	1.019×10^{-1}		
195.99	1.095		
206.46	1.176		
216.42	1.250		
266.17	1.321*		
236.17	1.382		
245.70	1.453		
256.33	1.520		
266.12	1.579		
276.14	1.638		
286.38	1.693		
296.24	1.748		
298.15	1.754*		
300.00	1.767*		
350.00	2.034		
400.00	2.211		
450.00	2.335		
500.00	2.427		
550.00	2.497		
600.00	2.553		
650.00	2.599		
700.00	2.637		
750.00	2.670		
800.00	2.698		
850.00	2.724		
900.00	2.747		
950.00	2.767		
1000.00	2.787		

* Not shown on plot

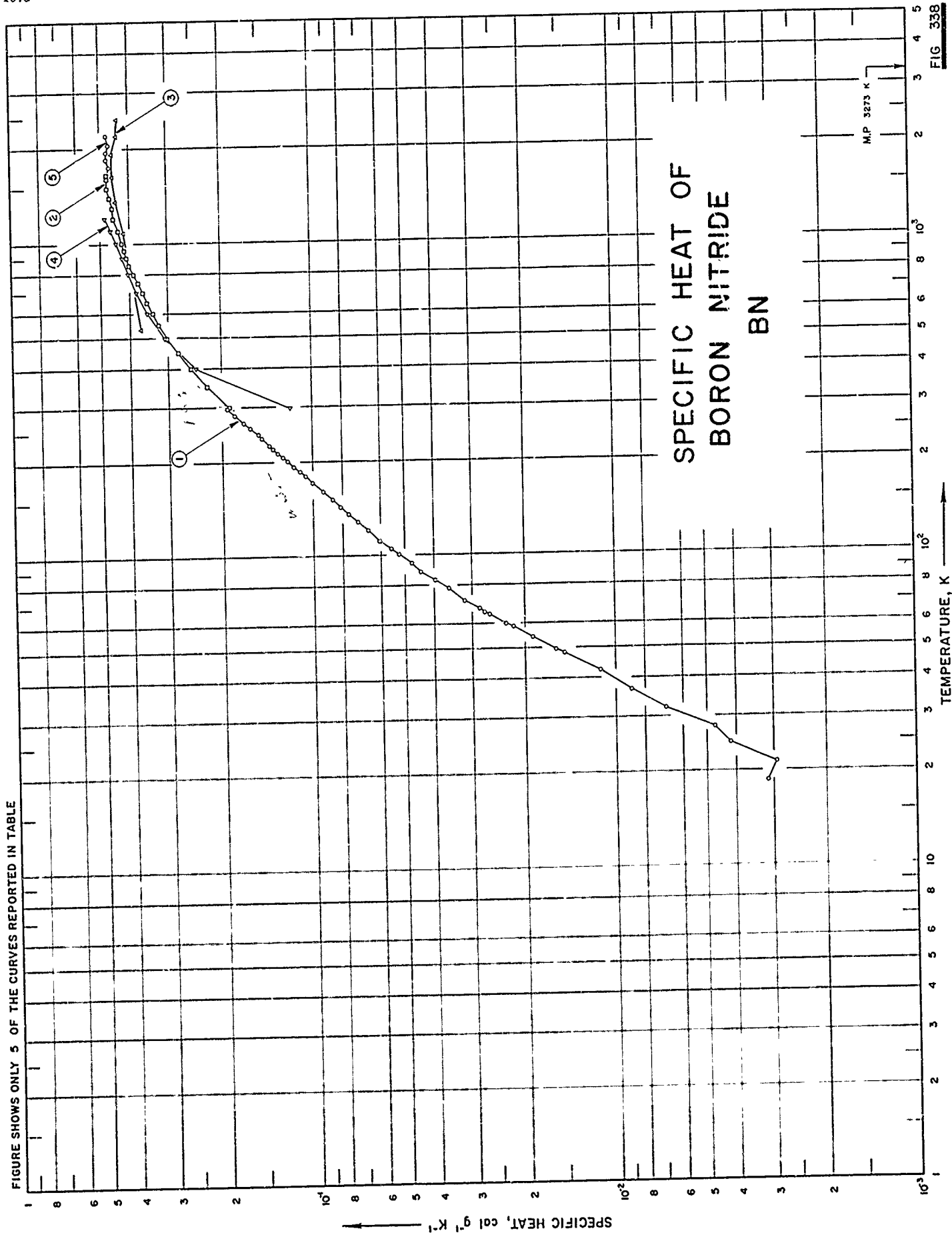

FIG. 338

SPECIFICATION TABLE NO. 338 SPECIFIC HEAT OF BORON NITRIDE BN

[For Data Reported in Figure and Table No. 338]

Curve No.	Ref. No.	Year	Temp. Range, K	Reported Error, %	Name and Specimen Designation	Composition (weight percent), Specifications and Remarks
1	214	1954	19-301	1.0		1.5 Fe as Fe ₂ O ₄
2	215	1961	300-1650			56.85 N and 42.81 B; sample supplied by The Carborundum Co. Before exposure: 52.4 N, 42.9 B, 0.2 Ca, 0.2 Ti, and 0.1 Si, after exposure: 55.0 N, 41.5 B, and 0.13 C; sample supplied by The Carborundum Co.; hot pressed; crushed in hardened steel mortar to pass 100-mesh screen; density at 25 C, before exposure: apparent density (ASTM method B311-58) 133.5 lb ft ⁻³ , true density (by immersion in xylene) 135 lb ft ⁻³ , after exposure: apparent density = 122 lb ft ⁻³ , true density = 135.5 lb ft ⁻³ .
3	48	1962	533-2478	≤5.0		
4	163	1962	298-1200	0.5	cubic	Traces of impurities.
5	38	1963	1300-2200	≤5.0		98.0 BN, 1.70 O; measured in an argon atmosphere.
6	414	1926	673-1173			

DATA TABLE NO. 338 SPECIFIC HEAT OF BORON NITRIDE BN

[Temperature, T, K; Specific Heat, Cp, Cal g⁻¹K⁻¹]

T	Cp	T	Cp	T	Cp	T	Cp	T	Cp
CURVE 1 (cont.)									
Series I									
157.11	8.949 x 10 ⁻² *	18.97	3.989 x 10 ⁻³	390	1.890 x 10 ⁻¹	298.16	1.189 x 10 ⁻¹		
164.95	9.513*	18.97	3.183	400	2.232	300	1.225*		
172.55	1.007	21.99	4.311	450	2.530	400	2.446		
180.23	1.061	25.26	4.311	500	2.792	500	3.087		
187.14	1.111	27.65	4.876	550	3.022	600	3.501		
194.17	1.168	32.59	6.769	550	3.224	700	3.804		
201.03	1.216	39.32	1.011 x 10 ⁻²	600	3.393	800	4.054		
207.75	1.264	46.25	1.374	650	3.530	900	4.267		
214.35	1.308	51.43	1.688*	700	3.663	1000	4.461		
220.81	1.362	201.65	1.222 x 10 ⁻² *	750	3.784	1100	4.642		
227.16	1.403	208.33	1.267*	800	3.892	1200	4.811		
233.39	1.451*	215.92	1.323*	850	4.001	CURVE 5			
Series IV									
49.94	1.575 x 10 ⁻²	232.77	1.446*	950	4.110	1300	4.525 x 10 ⁻² *		
54.53	1.866*	240.91	1.503*	1000	4.271	1350	4.593*		
60.54	2.313	248.90	1.560*	1050	4.352*	1400	4.598*		
67.75	2.841	256.73	1.617*	1100	4.392	1450	4.684*		
200.89	1.214 x 10 ⁻² *	264.41	1.679*	1150	4.473*	1500	4.686*		
214.19	1.303*	271.97	1.723*	1200	4.513	1550	4.662*		
220.65	1.357*	279.25	1.787*	1250	4.553*	1600	4.634*		
226.96	1.402*	286.54	1.849*	1300	4.593	1650	4.606*		
233.19	1.447*	293.72	1.895*	1350	4.634*	1700	4.618*		
239.32	1.488	300.80	1.930*	1400	4.674	1750	4.662		
245.36	1.533	Series VII*				1800	4.714*		
251.31	1.575*	68.58	2.893 x 10 ⁻²	1500	4.714*	1850	4.743		
257.17	1.617	74.64	3.361	1550	4.714*	1900	4.755*		
262.95	1.659*	80.90	3.804	1600	4.714	1950	4.730		
268.65	1.704	87.44	4.283	1650	4.714	2000	4.718*		
282.57	1.811	94.32	4.759	1700	4.714*	2050	4.694*		
289.82	1.860*	101.79	5.251	1750	4.714*	2100	4.694*		
296.97	1.911	108.68	5.766	1800	4.714*	2150	4.706*		
Series V									
18.56	3.143 x 10 ⁻³	115.23	6.185	1850	4.714*	2200	4.755		
21.42	2.941	121.48	6.528	1900	4.714	CURVE 6*			
24.56	4.191	128.45	6.983	1950	4.714	673	4.755	3.570 x 10 ⁻¹	
27.75	4.714	136.11	7.511	2000	4.714	773	4.960	3.720	
31.91	6.850	143.46	8.010	2050	4.714	823	4.990	3.854	
36.67	8.865	150.49	8.510	2100	4.714	873	4.990	4.078	
42.16	1.136 x 10 ⁻² *	157.42	8.953	2150	4.714	923	4.990	4.178	
48.27	1.495	164.65	9.465	2200	4.714	973	4.990	4.256	
Series III									
126.92	6.536 x 10 ⁻² *	164.65	9.465	22478	4.350	1023	4.990	4.324	
133.70	7.346*	18.56	3.143 x 10 ⁻³	2278	4.350	1073	4.990	4.378	
141.18	7.837*	21.42	2.941	2298	4.350	1123	4.990	4.422	
148.98	8.365*	24.56	4.191	2318	4.350	1173	4.990	4.448	

* Not shown on plot

FIG. 339

SPECIFIC HEAT OF HAFNIUM NITRIDE HfN

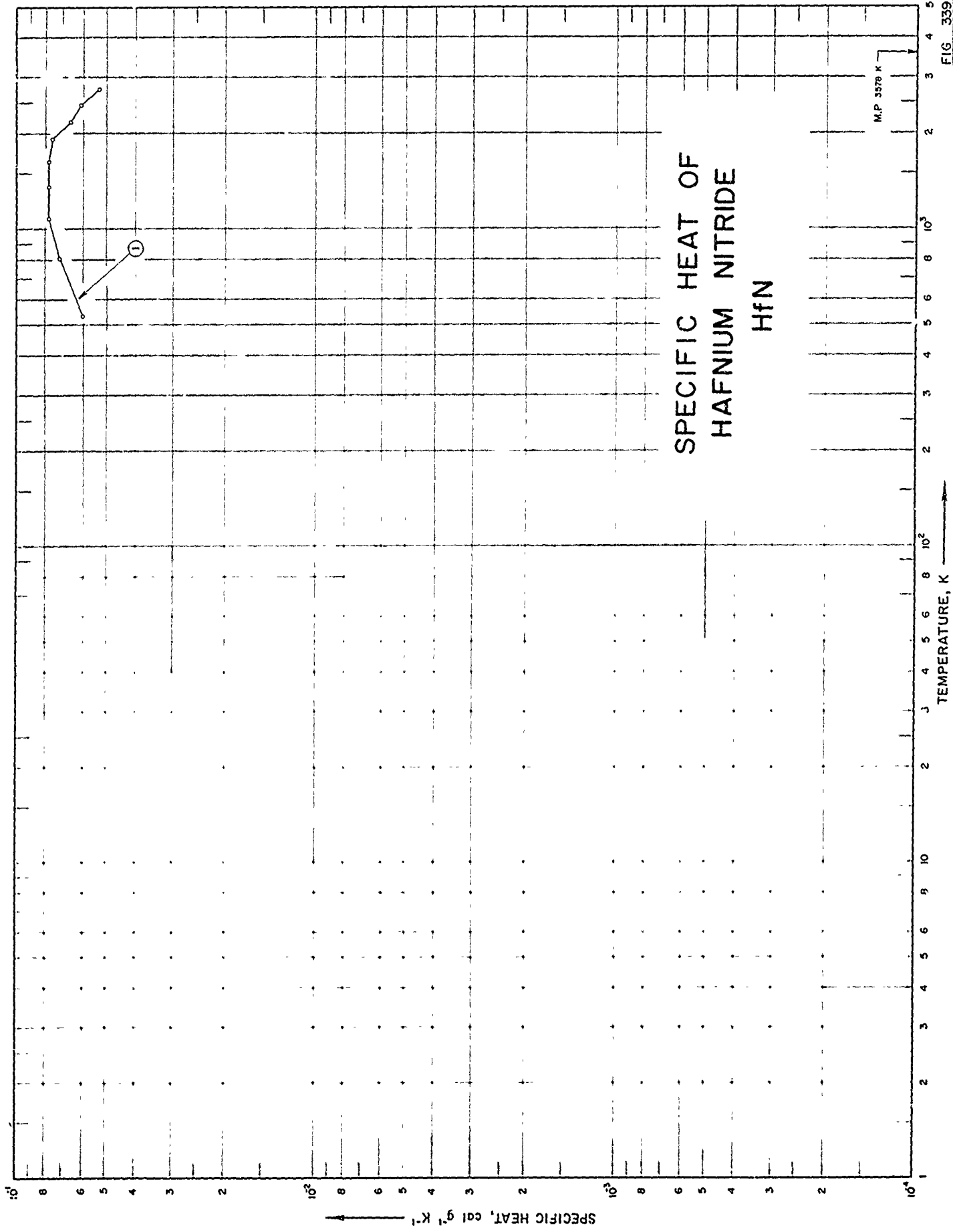

SPECIFICATION TABLE NO. 339 SPECIFIC HEAT OF HAFNIUM NITRIDE HfN

[For Data Reported in Figure and Table No. 339]

Curve No.	Ref. No.	Year	Temp. Range, K	Reported Error, %	Name and Specimen Designation	Composition (weight percent), Specifications and Remarks
1	32	1962	533-2755	±5.0		Wet analysis: 95.4 Hf, 6.61 N ₂ , and 0.9 O ₂ ; sample supplied by The Carborundum Co.; hot pressed (firing temperature near 6500 F); density = 677 lb ft ⁻³ .

DATA TABLE NO. 339 SPECIFIC HEAT OF HAFNIUM NITRIDE HfN
[Temperature, T, K; Specific Heat, Cp, Cal g⁻¹K⁻¹]

T	Cp
<u>CURVE 1</u>	
533	6.000 x 10 ²
811	7.200
1089	7.800
1366	7.800
1644	7.800
1922	7.600
2200	6.600
2478	6.100
2755	5.300

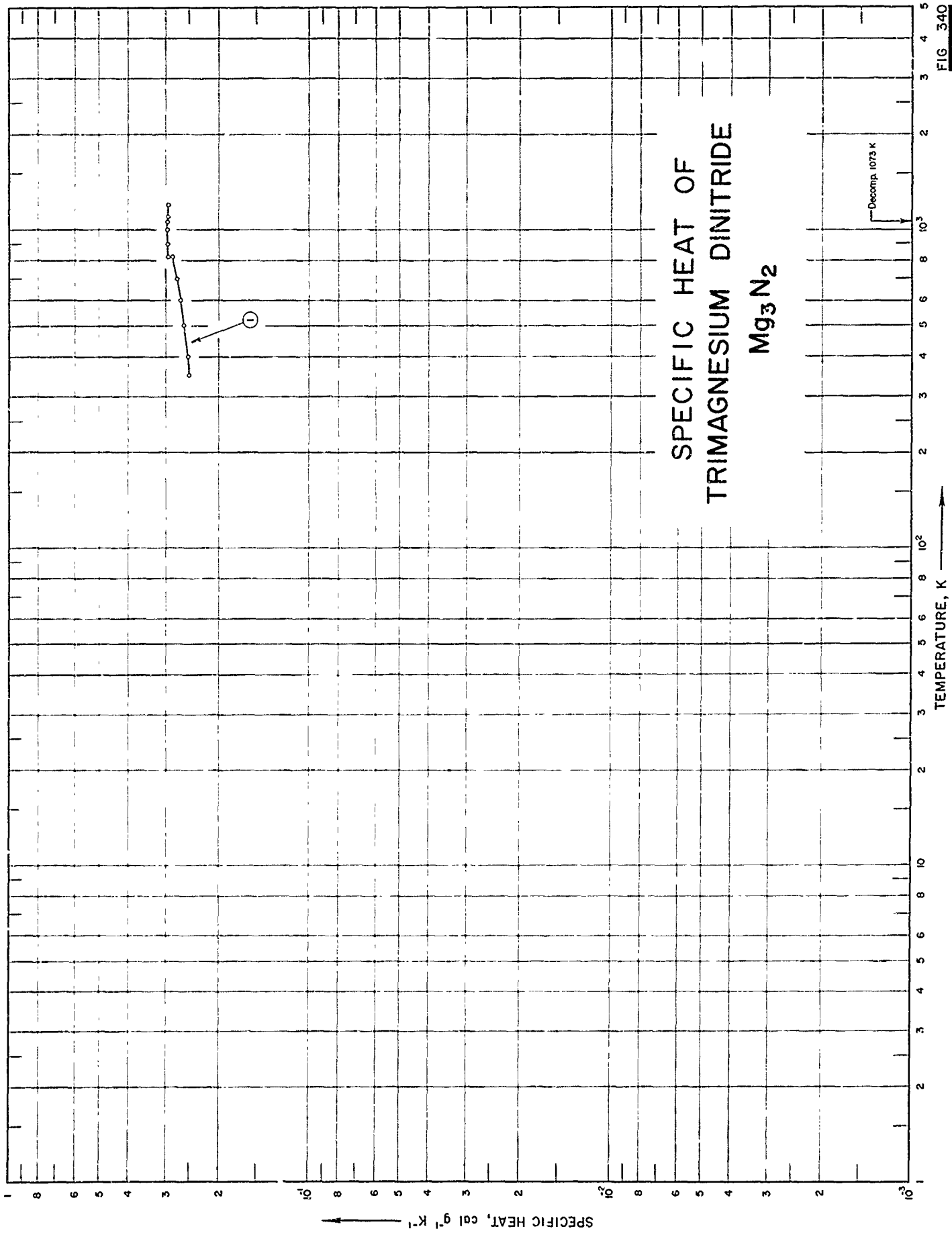

SPECIFICATION TABLE NO. 340 SPECIFIC HEAT OF THYMAGNESIUM DINITRIDE Mg_3N_2

[For Data Reported in Figure and Table No. 340]

Curve No.	Res. No.	Year	Temp. Range, K	Reported Error, %	Name and Specimen Designation	Composition (weight percent), Specifications and Remarks
1	216	1949	350-1200			99.1 Mg_3N_2 and 0.90 MgO; corrected for MgO content.

DATA TABLE NO. 340 SPECIFIC HEAT OF TRIMAGNESIUM DINITRIDE Mg_3N_2 [Temperature, T, K; Specific Heat, C_p , Cal $g^{-1}K^{-1}$]

T	C_p
<u>CURVE 1</u>	
350	2.511×10^{-1}
400	2.547
500	2.620
600	2.693
700	2.766
800	2.839
α 822	2.8558*
β 823	2.860*
900	2.960
1000	2.960
β 1061	2.960
γ 1061	2.954*
1100	2.954
1200	2.954

* Not shown on plot

FIG. 341

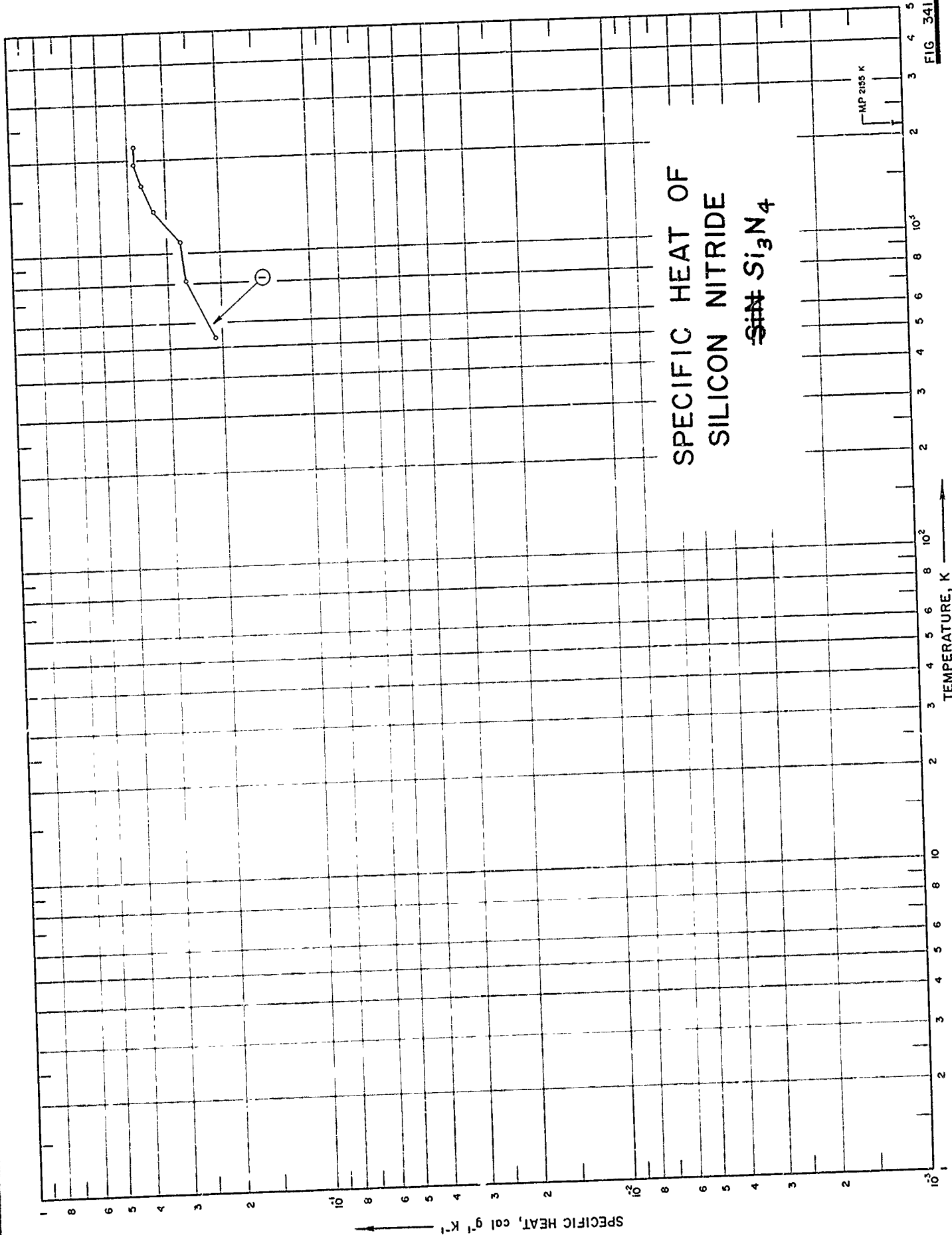

SPECIFICATION TABLE NO. 341 SPECIFIC HEAT OF SILICON NITRIDE ~~Si₃N₄~~ **Si₃N₄**

[For Data Reported in Figure and Table No. 341]

Curve No.	Ref. No.	Year	Temp. Range, K	Reported Error, %	Name and Specimen Designation	Composition (weight percent), Specifications and Remarks
1	32	1962	533-2200	≤5.0	Si₃N₄ Si₃N₄	98.12- 98.15 1.5 Fe, 0.3 Al, 0.05 Ca, 0.01 Cu, 0.01 Ni, 0.01 Ti, and traces of Ba, Mn, and Na; sample supplied by The Carborundum Co.; density = 148 lb ft ⁻³ .

DATA TABLE NO. 341 SPECIFIC HEAT OF SILICON NITRIDE Si_3N_4 [Temperature, T, K; Specific Heat, C_p , Cal $\text{g}^{-1}\text{K}^{-1}$]

T	C_p
<u>CURVE 1</u>	
533	2.100×10^{-1}
811	2.600
1089	2.700
1366	3.300
1644	3.600
1922	3.800
2200	3.800

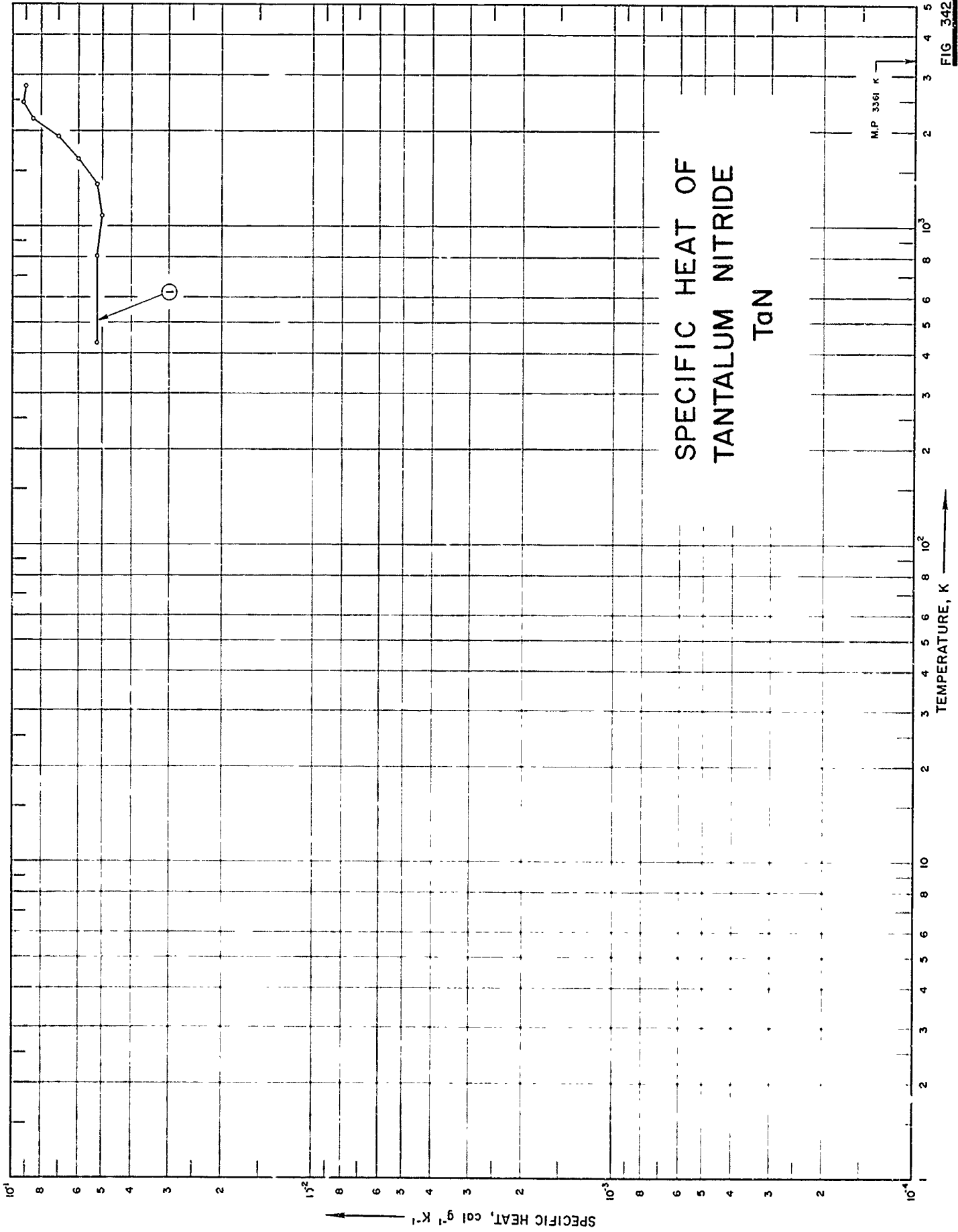

SPECIFIC HEAT OF
TANTALUM NITRIDE
TaN

M.P. 3361 K

FIG 342

SPECIFICATION TABLE NO. 342 SPECIFIC HEAT OF TANTALUM NITRIDE TaN

[For Data Reported in Figure and Table No. 342]

Curve No.	Ref. No.	Year	Temp. Range, K	Reported Error, %	Name and Specimen Designation	Composition (weight percent), Specifications and Remarks
1	48	1962	533-2755	±5.0		<p>Before exposure: 95.7 Ta, 3.5 N, 0.3 Fe, 0.2 Si, 0.13 C, and 0.1 Mg, after exposure: 95.5 Ta, 3.1 N, and 0.95 C; sample supplied by The Carborundum Co.; not pressed; crushed in hardened steel mortar to pass 100-mesh screen; density 25 C, before exposure: apparent density (ASTM method B311-58) 836 lb ft⁻³, true density (by immersion in xylene) 855 lb ft⁻³, after exposure: apparent density = 836 lb ft⁻³, true density = 910 lb ft⁻³.</p>

DATA TABLE NO. 342 SPECIFIC HEAT OF TANTALUM NITRIDE TaN
 [Temperature, T, K; Specific Heat, C_p , Cal $g^{-1}K^{-1}$]

T	C_p
CURVE 1	5.200×10^{-2}
533	5.200
811	5.000
1089	5.200
1366	5.200
1644	6.000
1922	7.000
2200	8.500
2478	9.200
2755	9.000

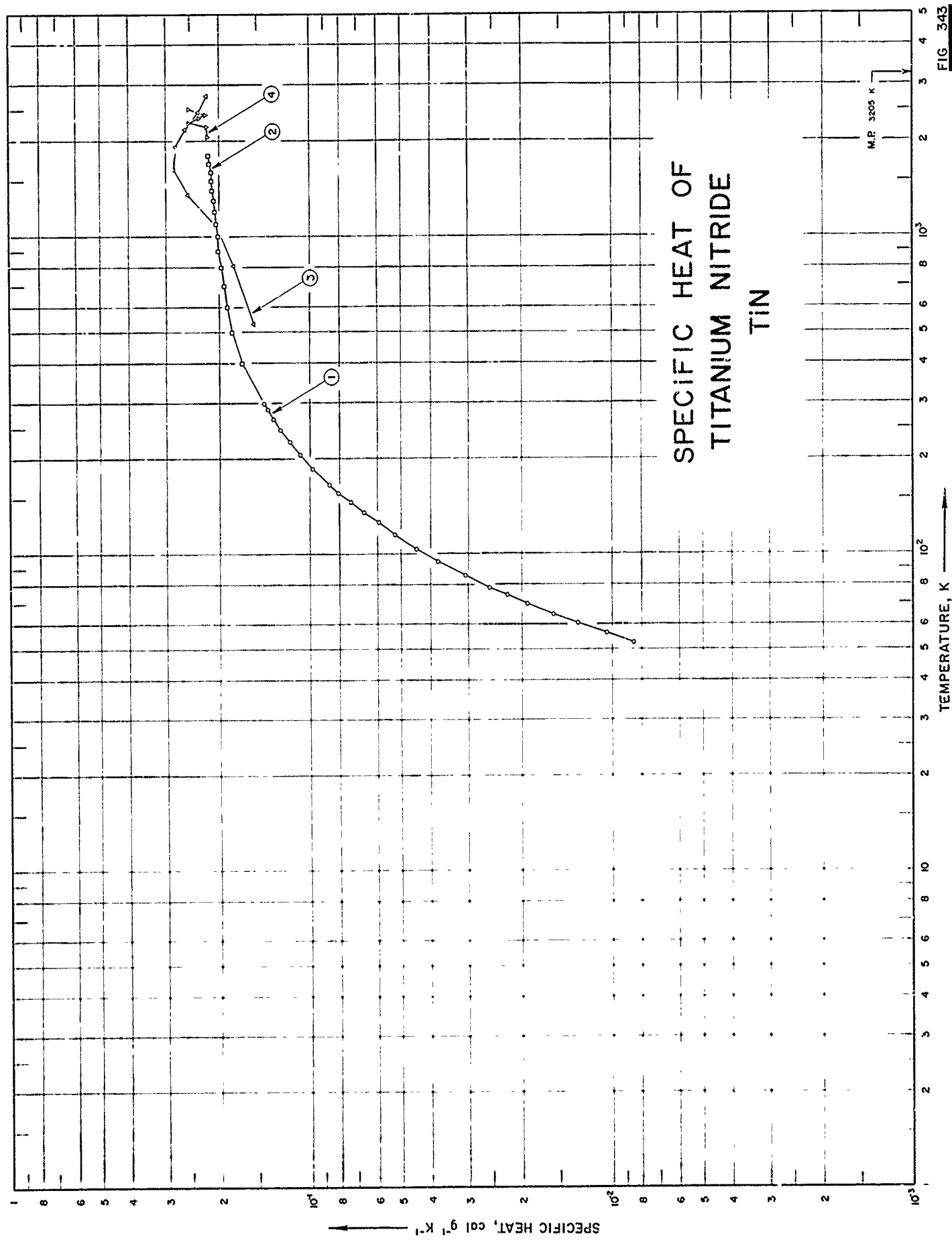

SPECIFICATION TABLE NO. 343 SPECIFIC HEAT OF TITANIUM NITRIDE TIN

[For Data Reported in Figure and Table No. 343]

Curve No.	Ref. No.	Year	Temp. Range, K	Reported Error, %	Name and Specimen Designation	Composition (weight percent), Specifications and Remarks
1	133	1946	53-298			99.5 TiN, and balance SiN; prepared by passing stream of purified N ₂ and H ₂ gas over titanium metal at 1400 C.
2	194	1946	298-1800			99.6 Ti; 77.04 Ti and SiN is the major impurity; prepared by heating powdered Ti in purified N ₂ and H ₂ gas at 1000 C and 10 hrs at 1100 C; density = 327 lb ft ⁻³ .
3	32	1962	533-2755	±5.0		Before exposure: 81.3 Ti, 17.0 N, 0.87 C, and 0.4 Fe, after exposure: 77.6 Ti, 18.9 N, and 1.2 C; sample supplied by the Technical Research Group; hot pressed; density at 25 C, before exposure: apparent density (ASTM method B311-58) 296 lb ft ⁻³ , true density (by immersion in xylene) 306 lb ft ⁻³ , after exposure: apparent density = 286 lb ft ⁻³ , true density = 321 lb ft ⁻³ .
4	173	1962	2052-2512	±5.0		

DATA TABLE NO. 343 SPECIFIC HEAT OF TITANIUM NITRIDE TIN

[Temperature, T, K; Specific Heat, C_p , Cal $g^{-1}K^{-1}$]

T	C_p	T	C_p
<u>CURVE 1</u>			
52.5	8.512×10^{-3}	1400	2.112×10^{-1}
56.4	1.058×10^{-2}	1500	2.130
63.5	1.307	1600	2.148
64.7	1.573	1700	2.166
69.7	1.821	1800	2.182
74.1	2.236	<u>CURVE 3</u>	
76.5	2.555	533	1.550×10^{-1}
85.3	3.056	811	1.800
94.9	3.765	1089	2.150*
104.6	4.492	1366	2.550
115.2	5.271	1644	2.850
125.2	5.983	1922	2.800
135.1	6.689	2200	2.600
145.8	7.393	2478	2.350
155.6	8.039	2755	2.200
165.7	8.654	<u>CURVE 4</u>	
175.7	9.263*	2052	2.190×10^{-1}
185.7	9.809	2217	2.200
196.1	1.035×10^{-2} *	2298	2.530
206.0	1.083	2350	2.340
216.3	1.134*	2418	2.210
226.3	1.177	2482	2.230*
235.9	1.215*	2512	2.530
246.0	1.255	<u>CURVE 2</u>	
258.0	1.293*	298.15	1.431×10^{-2} *
266.1	1.330	300	1.438*
276.4	1.365*	400	1.665
293.2	1.396	500	1.862
296.4	1.426*	600	1.882
298.16	1.431	700	1.932
		800	1.970
		900	2.001
		1000	2.028
		1100	2.051
		1200	2.072
		1300	2.093

* Not shown on plot

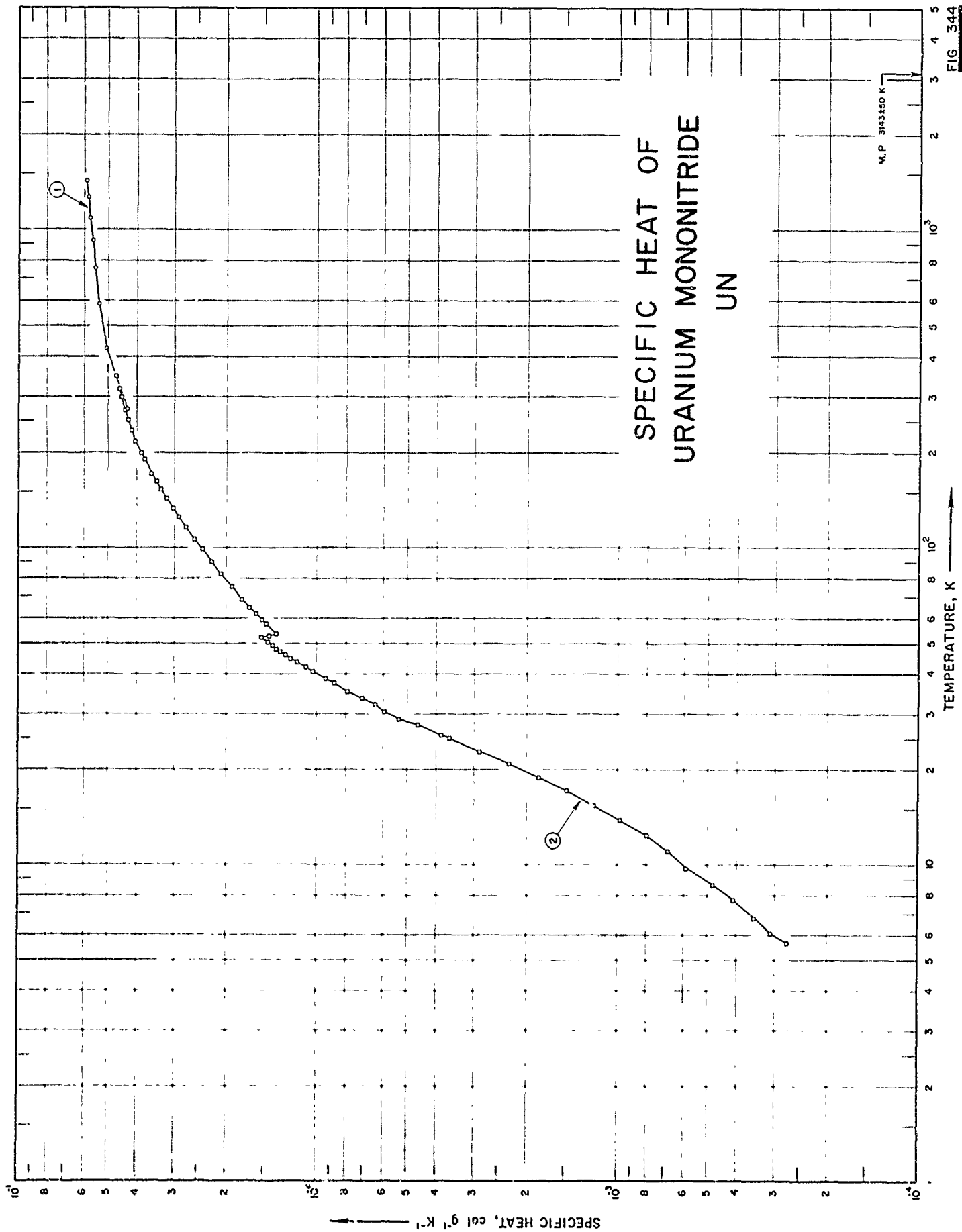

FIG. 344

SPECIFICATION TABLE NO. 344 SPECIFIC HEAT OF URANIUM NITRIDE UN

[For Data Reported in Figure and Table No. 344]

Curve No.	Ref. No.	Year	Temp. Range, K	Reported Error, %	Name and Specimen Designation	Composition (weight percent), Specifications and Remarks
1	416	1963	273-1422			Impurities: 5.24 N ₂ , and widely scattered small amount of UO ₂ ; single phase UN; isostatically hot pressed for 2 hrs at 1540 C and 10,000 psi.
2	415	1966	6-346			95.46 UN; 3.36 UO, 1.14 UC and 0.046 Fe (corrected for impurities).

DATA TABLE NO. 344 SPECIFIC HEAT OF URANIUM NITRIDE UN

[Temperature, T, K; Specific Heat, Cp, Cal g⁻¹K⁻¹]

T	Cp	T	Cp	T	Cp
<u>CURVE 1</u>					
273	4.30 x 10 ⁻²	8.66	4.841 x 10 ⁻⁴	43.67	1.171 x 10 ⁻²
422	5.02	9.77	5.912	46.19	1.286*
589	5.33	11.04	6.824	48.48	1.390*
755	5.50	12.41	8.015	50.60	1.490*
922	5.62	13.89	9.840	52.61	1.455
1089	5.73	15.46	1.198 x 10 ⁻³	54.62	1.403*
1255	5.82	17.13	1.480	56.59	1.455*
1422	5.92	18.87	1.833	58.47	1.509*
		20.78	2.297	60.27	1.562*
		22.85	2.888	Series V	
		25.06	3.626	25.64	3.872 x 10 ⁻³
		27.64	4.630	28.86	5.348
		30.48	5.955	64.81	1.687 x 10 ⁻²
		33.66	7.094	70.30	1.819*
		37.36	8.773	Series VI	
		38.52	9.356	32.08	6.424 x 10 ⁻³
		42.07	1.095 x 10 ⁻²	61.80	1.605 x 10 ⁻² *
		46.07	1.278	Series VII	
		61.97	1.607	44.94	1.228 x 10 ⁻²
		68.62	1.778	46.05	1.279*
		75.38	1.936	47.10	1.326
		82.54	2.102	48.12	1.376
		89.99	2.248	49.10	1.418*
		98.98	2.426	49.82	1.451*
		106.90	2.581	50.28	1.469
		116.26	2.753	50.74	1.486*
		Series III		51.18	1.519*
		35.46	7.943 x 10 ⁻³	51.62	1.543*
		42.55	1.120 x 10 ⁻² *	52.06	1.545
		46.44	1.297*	52.50	1.456*
		49.04	1.416	52.96	1.380*
		51.65	1.518*	53.42	1.378
		53.67	1.388*	53.88	1.384*
		57.53	1.483	Series IV	
		59.37	1.536	5.69	2.738 x 10 ⁻⁴
		61.14	1.586*	6.09	3.095
		62.84	1.634*	6.84	3.531
		Series II		7.70	4.126
		5.69	2.738 x 10 ⁻⁴	Series V	
		6.09	3.095	33.52	7.062 x 10 ⁻³ *
		6.84	3.531	37.57	8.899*
		7.70	4.126	40.84	1.041 x 10 ⁻²

* Not shown on plot

SPECIFIC HEAT OF URANIUM NITRIDE (Nonstoichiometric) UN_x

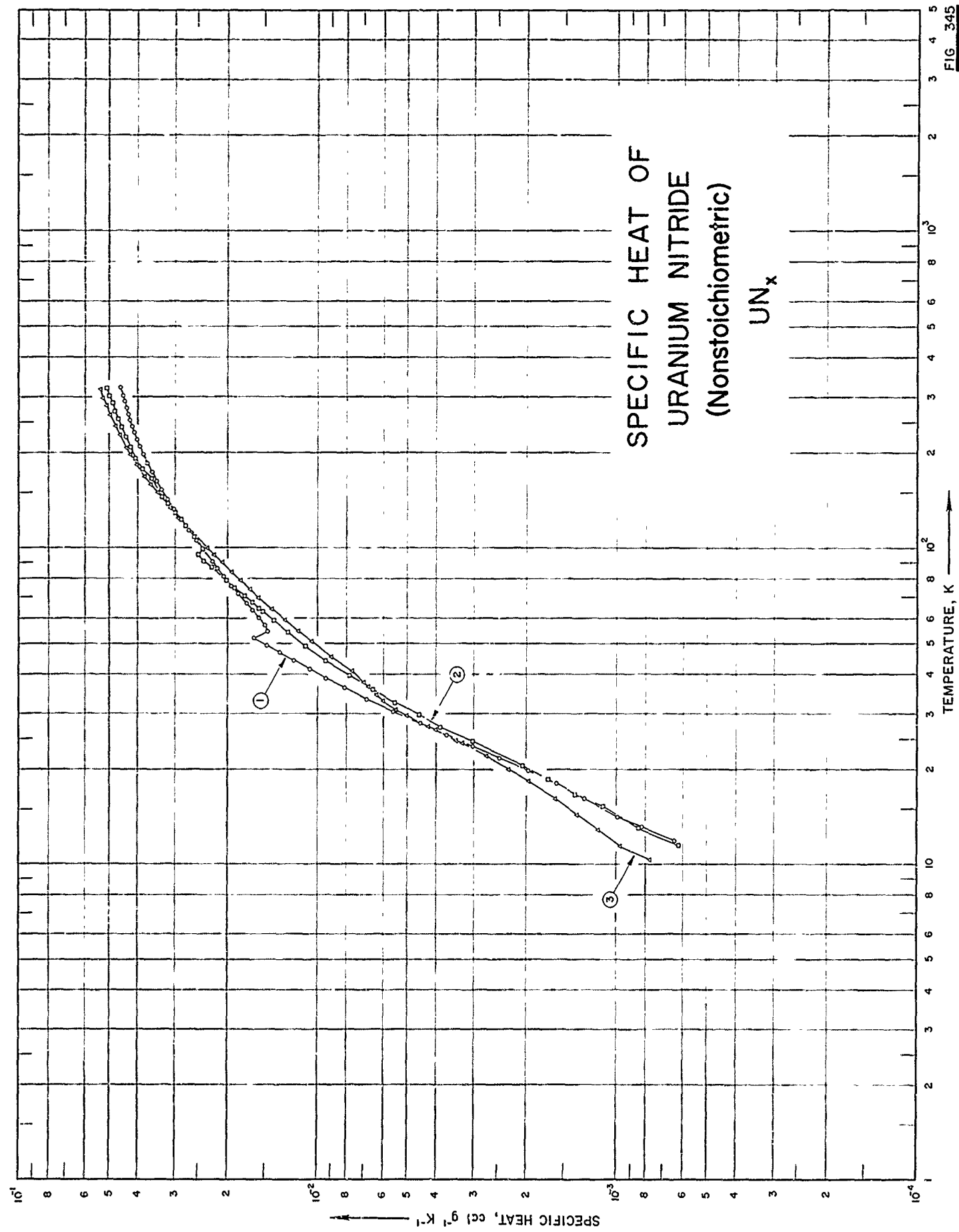

SPECIFICATION TABLE NO. 345 SPECIFIC HEAT OF URANIUM NITRIDE (nonstoichiometric) UN_x

[For Data Reported in Figure and Table No. 345]

Curve No.	Ref. No.	Year	Temp. Range, K	Reported Error, %	Name and Specimen Designation	Composition (weight percent), Specifications and Remarks
1	417	1966	12-324			UN _{1.01} ; 0.0119 UO ₂ .
2	417	1966	12-322	±0.1-0.4		UN _{1.59} ; 0.176 UO ₂ and 0.0416 UN.
3	417	1966	10-319	±0.1-0.4		UN _{1.73} ; 0.0098 UO ₂ .

DATA TABLE NO. 345 SPECIFIC HEAT OF URANIUM NITRIDE UN_x (nonstoichiometric)[Temperature, T, K; Specific Heat, Cp, Cal g⁻¹K⁻¹]

CURVE 1		CURVE 1 (cont.)		CURVE 2		CURVE 2 (cont.)		CURVE 3		CURVE 3 (cont.)	
T	C _p	T	C _p	T	C _p	T	C _p	T	C _p	T	C _p
11.82	6.40 x 10 ⁻⁴	153.61	3.351 x 10 ⁻²	11.57	6.2 x 10 ⁻⁴	134.35	3.114 x 10 ^{-2*}	10.38	7.70 x 10 ⁻⁴	120.56	2.827 x 10 ^{-2*}
13.12	8.20	158.69	3.420*	13.07	8.4	138.35	3.193	11.42	9.7	125.78	2.942
14.61	9.90	158.84	3.420*	15.27	1.16 x 10 ³	139.61	3.215*	12.78	1.15 x 10 ³	130.93	3.054*
16.22	1.27 x 10 ³	164.22	3.480	16.69	1.37	144.93	3.316*	13.15	1.19*	134.85	3.140
18.01	1.58	169.71	3.559*	18.62	1.69	146.53	3.345	14.39	1.35	137.36	3.195*
19.81	1.97	175.14	3.616	20.53	2.06	151.57	3.436*	16.14	1.60	141.36	3.274*
21.70	2.46	180.59	3.685*	24.59	3.04	156.72	3.530*	18.37	1.96	142.53	3.298*
23.63	3.03	186.05	3.745	27.17	3.88	161.68	3.607	19.99	2.29	147.59	3.402*
25.72	3.69	191.62	3.812*	29.82	4.57	166.85	3.697*	20.14	2.31*	150.03	3.446
28.02	4.53	192.86	3.813*	32.59	5.49	172.50	3.790*	22.07	2.72	154.88	3.542*
30.58	5.57	198.72	3.862	35.70	6.54	178.04	3.875	24.22	2.78*	159.64	3.632
33.43	6.84	204.49	3.916*	39.60	7.83	183.20	3.946*	24.22	3.27	164.31	3.719*
36.28	8.14	210.19	3.972	44.18	9.41	188.30	4.021*	24.70	3.44	168.91	3.802
38.93	9.38	215.79	4.018*	49.03	1.104 x 10 ²	193.34	4.088	26.66	4.00	171.33	3.838*
41.54	1.067 x 10 ⁻²	221.31	4.057	54.32	1.261	198.55	4.154*	27.48	4.26	173.44	3.885*
44.15	1.201	226.80	4.103*	59.19	1.409	203.88	4.214*	29.56	5.02	176.39	3.929*
46.75	1.340	232.55	4.145	59.47	1.416*	209.16	4.268	30.85	5.45	181.45	4.009*
49.36	1.481	238.27	4.176*	63.22	1.533	214.58	4.313*	32.89	6.03	183.57	4.042
52.00	1.631	243.93	4.211	64.65	1.574	220.29	4.371*	34.34	6.35	184.48	4.054*
54.63	1.473	249.58	4.254*	67.40	1.660	225.93	4.416	36.57	6.76	188.54	4.120*
57.30	1.500	255.16	4.291	70.59	1.756	231.51	4.467*	37.76	6.98	193.44	4.187*
60.28	1.572	257.22	4.285*	71.24	1.778*	237.03	4.517*	40.73	7.65	197.88	4.256
61.23	1.590*	266.10	4.333	75.27	1.906	242.49	4.572*	45.24	8.99	206.90	4.368*
63.72	1.656	267.99	4.358*	76.60	1.943*	247.86	4.619*	45.78	9.16*	208.62	4.403
67.04	1.733	272.95	4.366*	79.49	2.035	247.90	4.624*	50.78	1.061 x 10 ²	211.77	4.430*
72.18	1.857	275.71	4.384*	82.06	2.112*	252.00	4.656*	54.54	1.165	213.47	4.460*
76.35	1.953	278.28	4.409	82.10	2.110*	253.25	4.671*	54.71	1.163*	216.66	4.499*
81.59	2.075	281.12	4.400*	87.13	2.267	256.69	4.699	55.91	1.198*	223.51	4.578*
86.60	2.180	283.57	4.429*	87.19	2.267*	261.38	4.724*	59.29	1.288*	228.50	4.625
90.75	2.265	286.28	4.424*	87.52	2.278	266.11	4.765*	59.54	1.292	231.61	4.663*
91.64	2.282*	288.83	4.460*	91.15	2.419	271.28	4.808	64.28	1.426	238.36	4.738*
94.22	2.333*	291.64	4.478	92.43	2.460*	276.38	4.817*	69.68	1.570	242.83	4.789*
97.95	2.401*	294.06	4.495*	95.33	2.507	281.30	4.866*	74.04	1.687	243.29	4.796
101.85	2.477*	297.09	4.478*	97.91	2.447*	286.19	4.896*	75.05	1.713*	248.26	4.849*
106.00	2.558	299.27	4.502*	99.40	2.421	289.47	4.917	79.14	1.819	253.20	4.907*
110.26	2.639*	300.44	4.503*	103.43	2.483*	291.05	4.926*	80.07	1.833*	258.11	4.960*
114.52	2.713	302.28	4.508*	108.53	2.591	296.02	4.939*	84.16	1.948	264.40	4.997
118.91	2.793*	304.45	4.533*	112.56	2.672*	301.09	4.986*	90.17	2.095	269.72	5.045*
123.40	2.878*	305.98	4.535*	113.72	2.692	304.69	5.014	95.39	2.231	273.26	5.091*
128.22	2.961*	307.57	4.544*	117.51	2.773	306.21	5.021*	100.07	2.345	278.35	5.113*
133.30	3.050	312.97	4.547*	124.01	2.895	311.36	5.050*	100.54	2.356*	283.54	5.142
138.41	3.129*	318.35	4.575*	127.83	2.985*	314.54	5.070*	105.19	2.460*	288.57	5.194*
143.48	3.203	323.70	4.623	129.16	3.007	316.50	5.074*	110.18	2.583*	290.33	5.204*
148.52	3.283*			131.80	3.062*	321.59	5.100	115.79	2.718*	295.32	5.230*
										298.55	5.262
										300.36	5.262*

* Not shown on plot

DATA TABLE NO. 345 (continued)

T	C _p
<u>CURVE 3 (cont.)</u>	
303.51	5.284 x 10 ² *
305.44	5.300*
308.52	5.330*
313.56	5.347*
318.57	5.386

* Not shown on plot

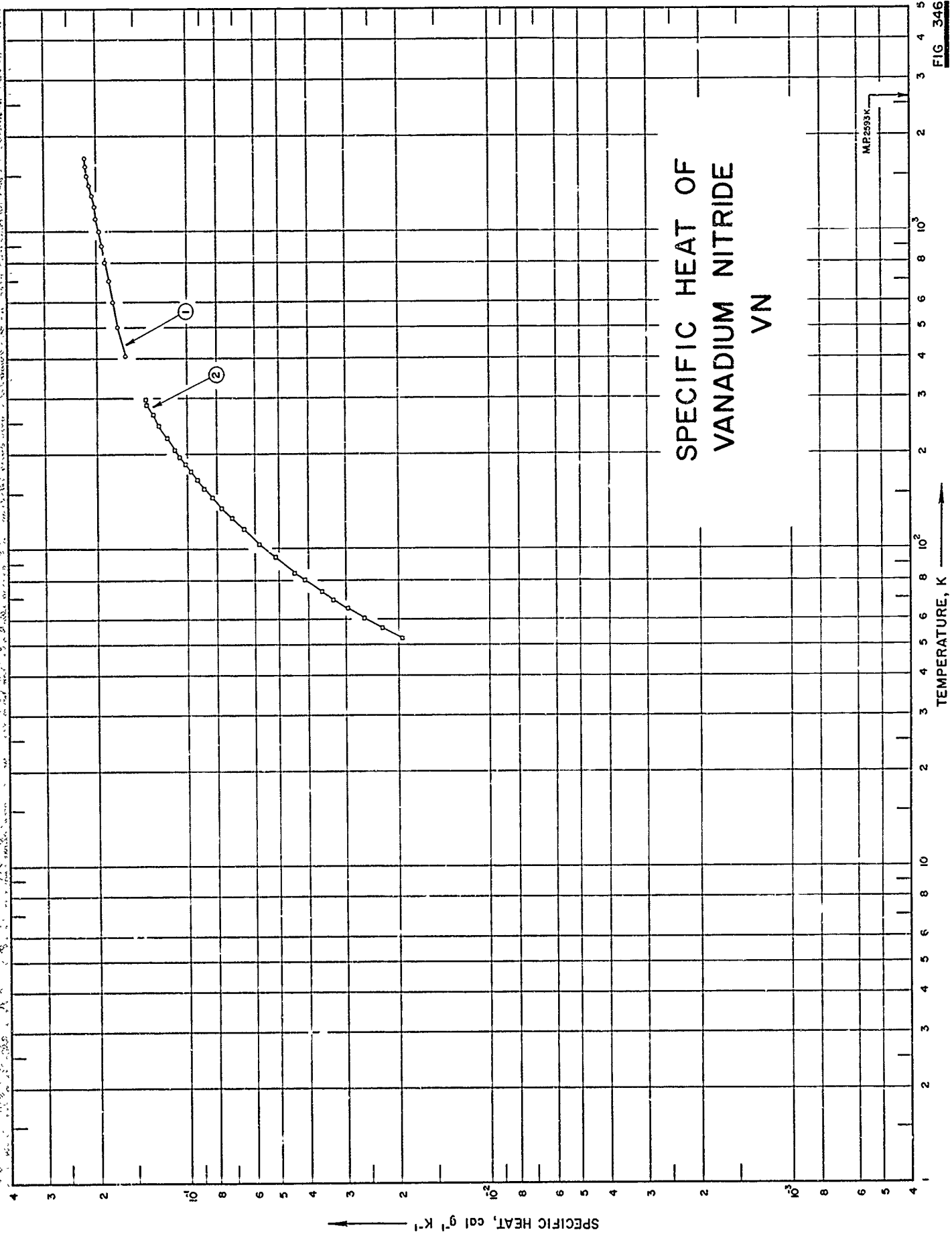

SPECIFICATION TABLE NO. 346 SPECIFIC HEAT OF VANADIUM NITRIDE VN

[For Data Reported in Figure and Table No. 346]

Curve No.	Ref. No.	Year	Temp. Range, K	Reported Error, %	Name and Specimen Designation	Composition (weight percent), Specifications and Remarks
1	205	1949	408-1611			78.24 V and 0.05 C (theor. 78.43 V); heated 24 hrs at 1200 C; mixture cooled and ground at 7 hrs interval.
2	204	1949	53-298			78.24 V and 0.05 C (theor. 78.43 V); heated 28 hrs at 1200 C; mixture cooled and reground at 7 hrs interval.

DATA TABLE NO. 346 SPECIFIC HEAT OF VANADIUM NITRIDE VN

[Temperature, T, K, Specific Heat, Cp, Cal g⁻¹K⁻¹]

T	C _p
<u>CURVE 1</u>	
408	1.612 x 10 ⁻¹
500	1.710
600	1.784
700	1.841
800	1.890
900	1.933
1000	1.973
1100	2.012
1200	2.048
1300	2.084
1400	2.119
1500	2.154
1600	2.188
1611	2.192

T	C _p
<u>CURVE 2</u>	
52.6	1.958 x 10 ⁻²
56.7	2.284
60.9	2.620
65.1	2.963
69.4	3.310
73.5	3.641
80.0	4.178
84.8	4.490
94.7	5.197
104.5	5.864
115.1	6.550
125.1	7.157
135.0	7.752
145.6	8.333
155.5	8.865
165.4	9.367
175.3	9.875
185.6	1.031 x 10 ⁻¹
195.9	1.075
205.8	1.115
216.1	1.152*
226.1	1.180
235.8	1.220*
246.1	1.256
256.1	1.290*
266.0	1.316
276.0	1.343*
286.1	1.370
296.3	1.394*
298.16	1.398

* Not shown on plot

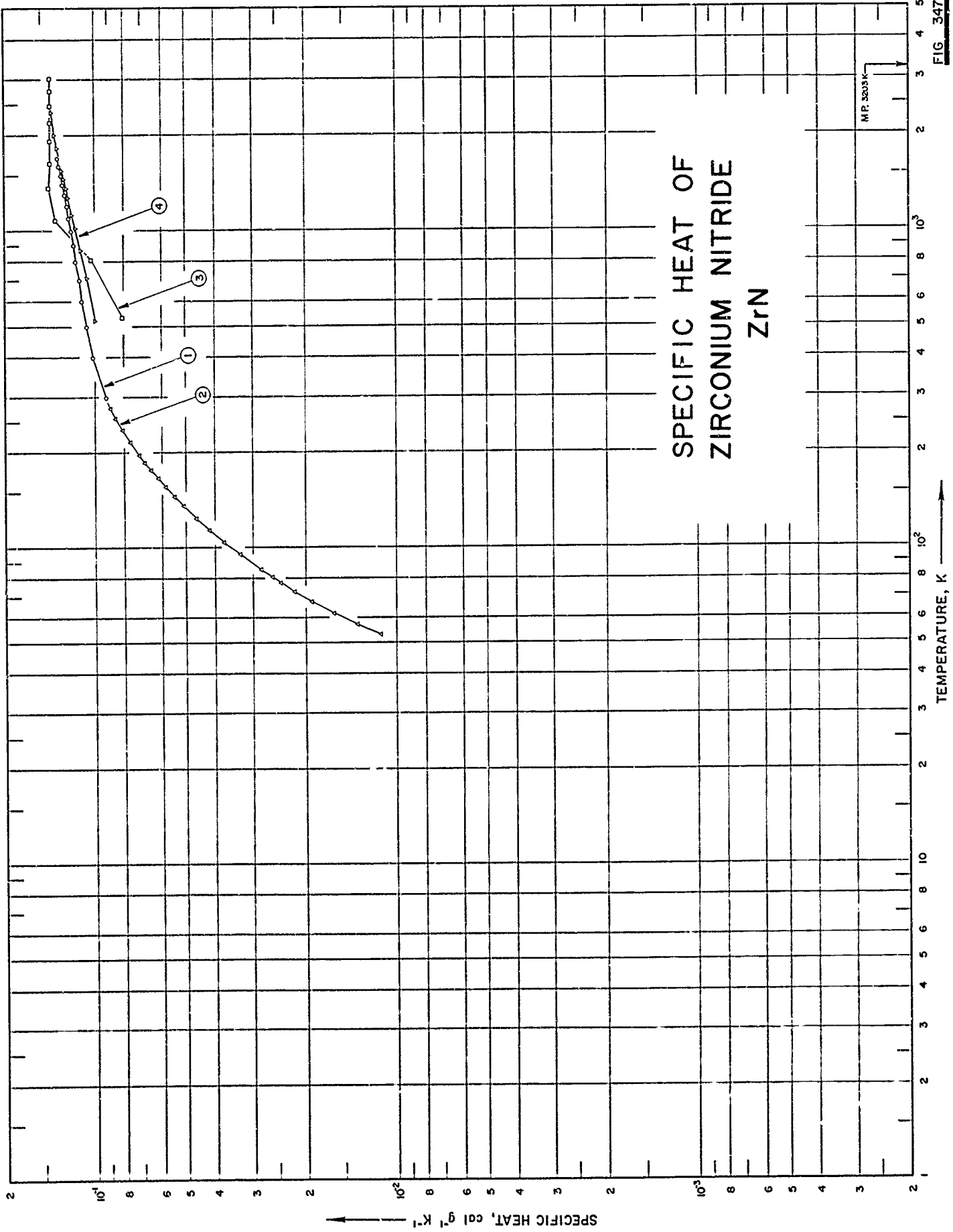

FIG. 347

SPECIFICATION TABLE NO. 347 SPECIFIC HEAT OF ZIRCONIUM NITRIDE ZrN

[For Data Reported in Figure and Table No. 347]

Curve No.	Ref. No.	Year	Temp. Range, K	Reported Error, %	Name and Specimen Designation	Composition (weight percent), Specifications and Remarks
1	154	1950	298-1700			86.75 Zr including 1.35 Hf (theor. 86.69 Zr).
2	217	1950	53-298			86.75 Zr (theor. 86.69 Zr), 1.35 Hf; corrected for impurities.
3	32	1962	533-3033	±5.0		Before exposure: 86.9 Zr, 12.8 N, and 0.1 Fe, after exposure: 86.5 Zr, 10.8 N, and 1.19 C; sample supplied by General Electric Co.; pressed and sintered; density at 25 C, before exposure: apparent density (ASTM method B311-58) 450 lb ft ⁻³ , true density (by immersion in xylene) 450 lb ft ⁻³ , after exposure: apparent density = 425 lb ft ⁻³ , true density = 437 lb ft ⁻³ .
4	47	1963	522-2770	±5.0		84.6 Zr, 13.5 N, 0.8 H, 0.5 alkali metal oxides, 0.4 Si, and 0.2 Fe; sample supplied by the Norton Co.; hot pressed.

DATA TABLE NO. 347 SPECIFIC HEAT OF ZIRCONIUM NITRIDE ZrN

[Temperature, T, K; Specific Heat, Cp, Cal g⁻¹K⁻¹]

T	C _p	T	C _p
<u>CURVE 1</u>			
298	9.183 x 10 ⁻²	276.6	8.862 x 10 ⁻²
300	9.211*	286.8	9.011*
400	1.017 x 10 ⁻¹	296.7	9.135*
500	1.069	<u>CURVE 3</u>	
600	1.105	533	8.100 x 10 ⁻²
700	1.133	811	1.030 x 10 ⁻¹
800	1.157	1083	1.350
900	1.178	1366	1.420
1000	1.198	1644	1.400
1200	1.235	1922	1.400
1300	1.253	2200	1.400
1400	1.270	2478	1.40
1500	1.287	2755	1.400
1600	1.304	3033	1.400
1700	1.321	<u>CURVE 4</u>	
<u>CURVE 2</u>			
53.1	1.138 x 10 ⁻²	523	9.98 x 10 ⁻²
57.1	1.355	713	1.066 x 10 ⁻¹
62.6	1.615	871	1.118
67.5	1.918	1022	1.163
72.7	2.193	1133	1.193
77.6	2.446	1282	1.231
80.5	2.595	1367	1.240
85.3	2.830	1457	1.270
95.2	3.304	1551	1.289
104.8	3.750	1698	1.318*
114.9	4.197	1833	1.336
124.8	4.625	2008	1.359
136.2	5.092	2108	1.369*
145.9	5.461	2244	1.380*
155.9	5.832	2386	1.388
166.2	6.193	2519	1.392*
176.7	6.534	2666	1.393*
186.2	6.820	2772	1.392*
196.4	7.121		
206.7	7.397*		
216.6	7.648		
226.5	7.875*		
236.5	8.093		
246.0	8.281*		
256.4	8.509		
266.4	8.673*		

* Not shown on plot

SPECIFIC HEAT OF BARIUM CARBONATE $BaCO_3$

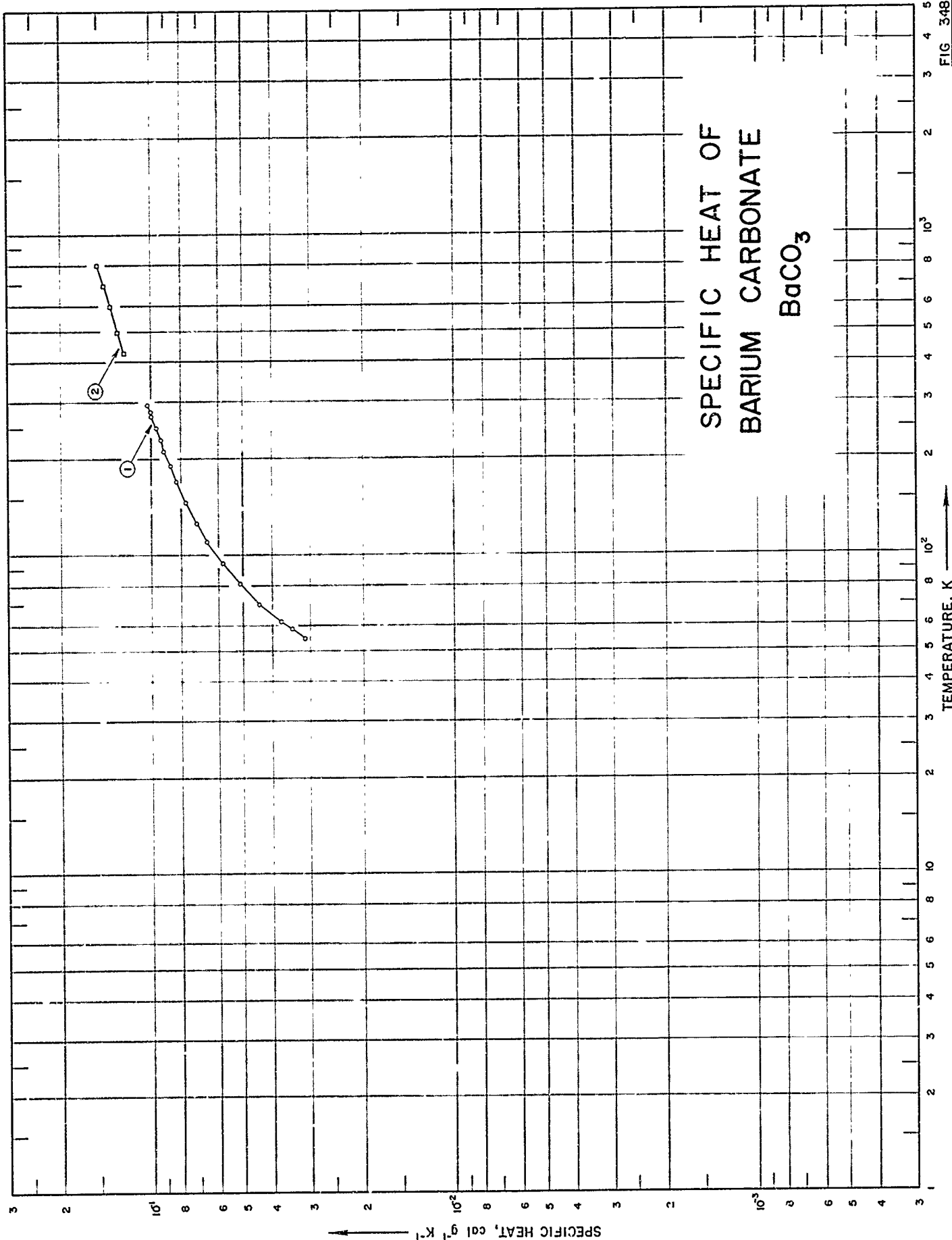

SPECIFICATION TABLE NO. 348 SPECIFIC HEAT OF BARIUM CARBONATE, BaCO₃

[For Data Reported in Figure and Table No. 348]

Curve No.	Ref. No.	Year	Temp. Range, K	Reported Error, %	Name and Specimen Designation	Composition (weight percent), Specifications and Remarks
1	427	1934	55-296		Witherite	99.9 BaCO ₃ .
2	42	1951	431-806			Exceptionally high purity.

DATA TABLE NO. 348 SPECIFIC HEAT OF BARIUM CARBONATE, BaCO₃
 [Temperature, T, K; Specific Heat, C_p, Cal g⁻¹K⁻¹]

T	C _p
<u>CURVE 1</u>	
54.8	3.140 x 10 ⁻²
58.7	3.457
61.9	3.764
69.9	4.442
81.0	5.118
94.4	5.837
111.8	6.592
126.8	7.129
147.9	7.722
171.1	8.264
191.8	8.675
212.4	9.151
230.9	9.343
250.6	9.668
272.8	1.005 x 10 ⁻¹
281.2	1.004
295.9	1.032
<u>CURVE 2</u>	
431	1.230 x 10 ⁻¹
506	1.291
600	1.368
706	1.438
800	1.504*
806	1.508

* Not shown on plot

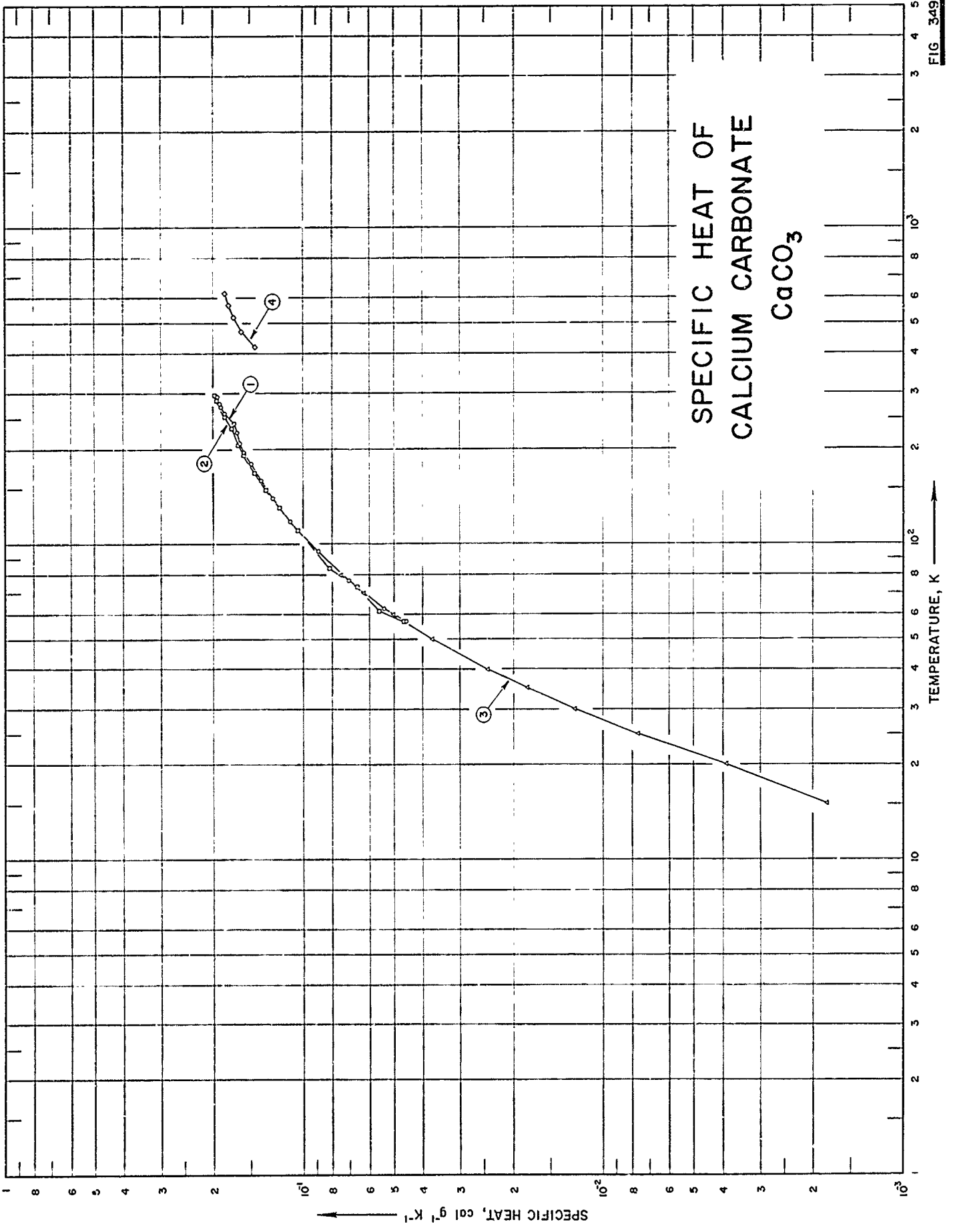

FIG. 349

SPECIFICATION TABLE NO. 349 SPECIFIC HEAT OF CALCIUM CARBONATE, CaCO_3

[For Data Reported in Figure and Table No. 349]

Curve No.	Ref. No.	Year	Temp. Range, K	Reported Error, %	Name and Specimen Designation	Composition (weight percent), Specifications and Remarks
1	427	1934	57-294		Coarse Calcite	99.970 CaCO_3 .
2	427	1934	57-297		Fine Calcite	98.656 CaCO_3 , 0.725 CaOH and 0.618 H_2O .
3	314	1935	15-80			
4	428	1961	423-623		Limestone (Madhya Pradesh)	

DATA TABLE NO. 349 SPECIFIC HEAT OF CALCIUM CARBONATE, CaCO₃[Temperature, T, K; Specific Heat, C_p, Cal g⁻¹K⁻¹]

T	C _p	T	C _p
<u>CURVE 1</u>			
57.2	4.555 x 10 ⁻²	60	5.03 x 10 ⁻²
62.6	5.440	70	6.31
77.5	7.053	80	7.49
95.7	8.938	<u>CURVE 4</u>	
118.6	1.110 x 10 ⁻¹	423	1.445 x 10 ⁻¹
141.5	1.273	473	1.610
159.7	1.384	523	1.704
180.0	1.492	573	1.769
196.5	1.585	623	1.821
209.2	1.633	<u>CURVE 2</u>	
227.4	1.668	57.0	4.634 x 10 ⁻²
241.9	1.703	61.6	5.601
261.0	1.833	73.5	6.606
272.5	1.887	84.4	8.158
279.8	1.904	111.5	1.045 x 10 ⁻¹
294.3	1.943	131.3	1.208
<u>CURVE 3</u>			
57.0	4.634 x 10 ⁻²	148.5	1.328
61.6	5.601	168.3	1.453
73.5	6.606	192.4	1.581
84.4	8.158	207.7	1.649
111.5	1.045 x 10 ⁻¹	233.7	1.731
131.3	1.208	254.1	1.838
148.5	1.328	272.1	1.905*
168.3	1.453	287.5	1.948
192.4	1.581	296.5	1.978
207.7	1.649	<u>CURVE 3</u>	
233.7	1.731	15	1.80 x 10 ⁻³
254.1	1.838	20	3.90
272.1	1.905*	25	7.69
287.5	1.948	30	1.25 x 10 ⁻²
296.5	1.978	35	1.80
<u>CURVE 3</u>			
15	1.80 x 10 ⁻³	40	2.43
20	3.90	50	3.73
25	7.69		
30	1.25 x 10 ⁻²		
35	1.80		
40	2.43		
50	3.73		

* Not shown on plot

FIG. 350

SPECIFIC HEAT OF CALCIUM MAGNESIUM DICARBONATE $\text{CaMg}(\text{CO}_3)_2$

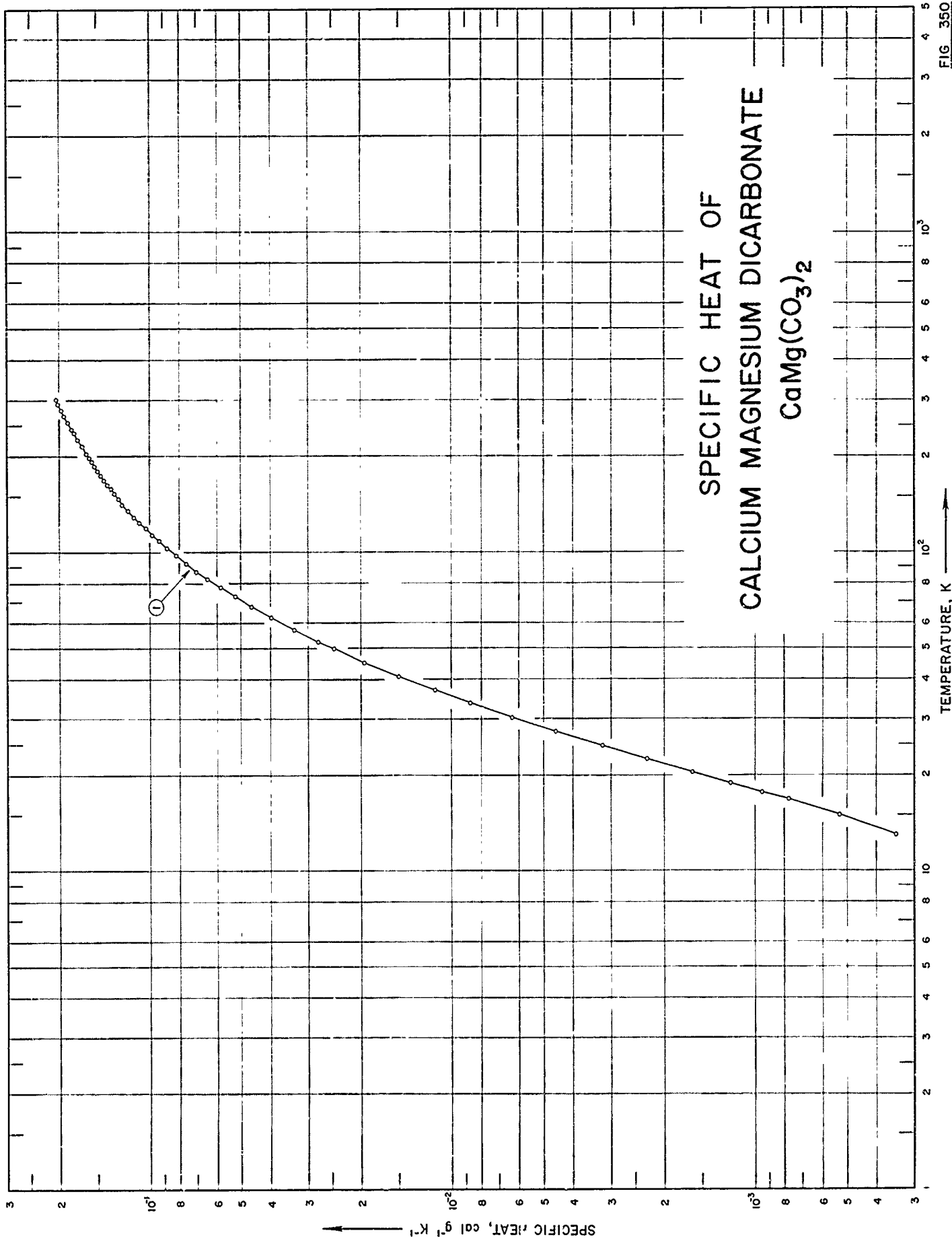

SPECIFICATION TABLE NO. 350 SPECIFIC HEAT OF CALCIUM MAGNESIUM DICARBONATE, $\text{CaMg}(\text{CO}_3)_2$

{ For Data Reported in Figure and Table No. 350 }

Curve No.	Ref. No.	Year	Temp. Range, K	Reported Error, %	Name and Specimen Designation	Composition (weight percent), Specifications and Remarks
1	429	1963	12-301		Dolomite	47.38 CO_2 , 30.77 CaO , 21.54 MgO , 0.10 MnO , 0.017 SrO , and 0.008 FeO ; crushed in porcelain mortar.

DATA TABLE NO. 350 SPECIFIC HEAT OF CALCIUM MAGNESIUM DICARBONATE, $\text{CaMg}(\text{CO}_3)_2$ [Temperature, T, K; Specific Heat, C_p , Cal $\text{g}^{-1} \text{K}^{-1}$]

T	C_p	T	C_p
52.68	2.771×10^{-2}	297.89	2.044×10^{-4}
57.37	3.326	301.10	2.952
62.69	3.972		
67.95	4.619	Series II	
73.03	5.235	11.64	2.408×10^{-4}
78.10	5.859	13.10	3.459
82.99	6.469	15.00	5.314
87.64	7.017	16.74	7.814
92.93	7.618	17.69	9.565
98.50	8.220	18.90	1.213×10^{-3}
103.96	8.801	20.49	1.626
109.21	9.337	22.51	2.283
114.52	9.863	24.78	3.205
120.04	1.038×10^{-1}	27.51	4.569
125.41	1.088	30.47	6.360
130.95	1.136	33.75	8.714
136.56	1.184	37.05	1.145×10^{-2}
142.23	1.240	40.99	1.509
147.89	1.273	45.34	1.950
153.49	1.313	50.03	2.467
159.12	1.353	238.31	1.793×10^{-1}
164.66	1.391	251.17	1.851*
170.20	1.427	257.01	1.878*
175.83	1.462	262.31	1.897*
181.53	1.497	268.88	1.928*
187.19	1.530	276.51	1.960*
193.00	1.564	282.43	1.986*
198.77	1.595	288.65	2.010*
204.37	1.626		
210.13	1.656*		
216.00	1.687		
222.00	1.716*		
227.74	1.745		
233.60	1.769*		
244.85	1.825		
250.55	1.850*		
256.44	1.876		
262.61	1.901*		
268.60	1.929		
274.46	1.953*		
280.38	1.976		
286.44	2.000*		
292.15	2.021		

* Not shown on plot

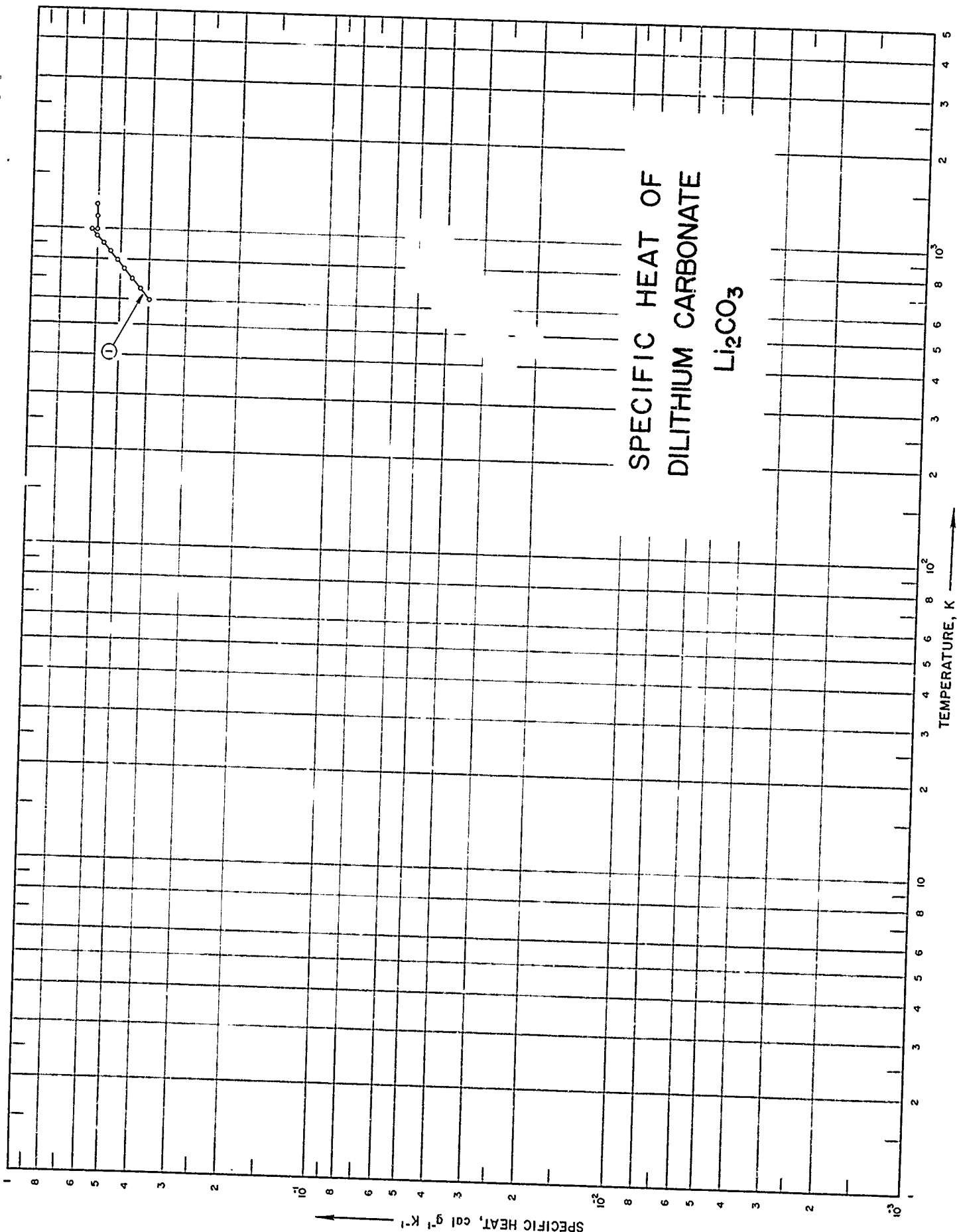

FIG. 351

SPECIFICATION TABLE NO. 351 SPECIFIC HEAT OF DILITHIUM CARBONATE, Li_2CO_3

[For Data Reported in Figure and Table 351]

Curve No.	Ref. No.	Year	Temp. Range, K	Reported Error, %	Name and Specimen Designation	Composition (weight percent), Specifications and Remarks
1	430	1963	600-1150			Baker analyzed reagents.

DATA TABLE NO. 351 SPECIFIC HEAT OF LITHIUM CARBONATE, Li_2CO_3
 [Temperature, T, K; Specific Heat, C_p , Cal $\text{g}^{-1}\text{K}^{-1}$]

T	C_p
	CURVE 1
600	3.989×10^{-1}
650	4.278
700	4.567
750	4.856
800	5.145
850	5.435
900	5.724
950	6.013
(s) 996	5.279
(L) 996	6.002
1000	6.009*
1100	6.017
1150	6.027

* Not shown on plot

FIG 352

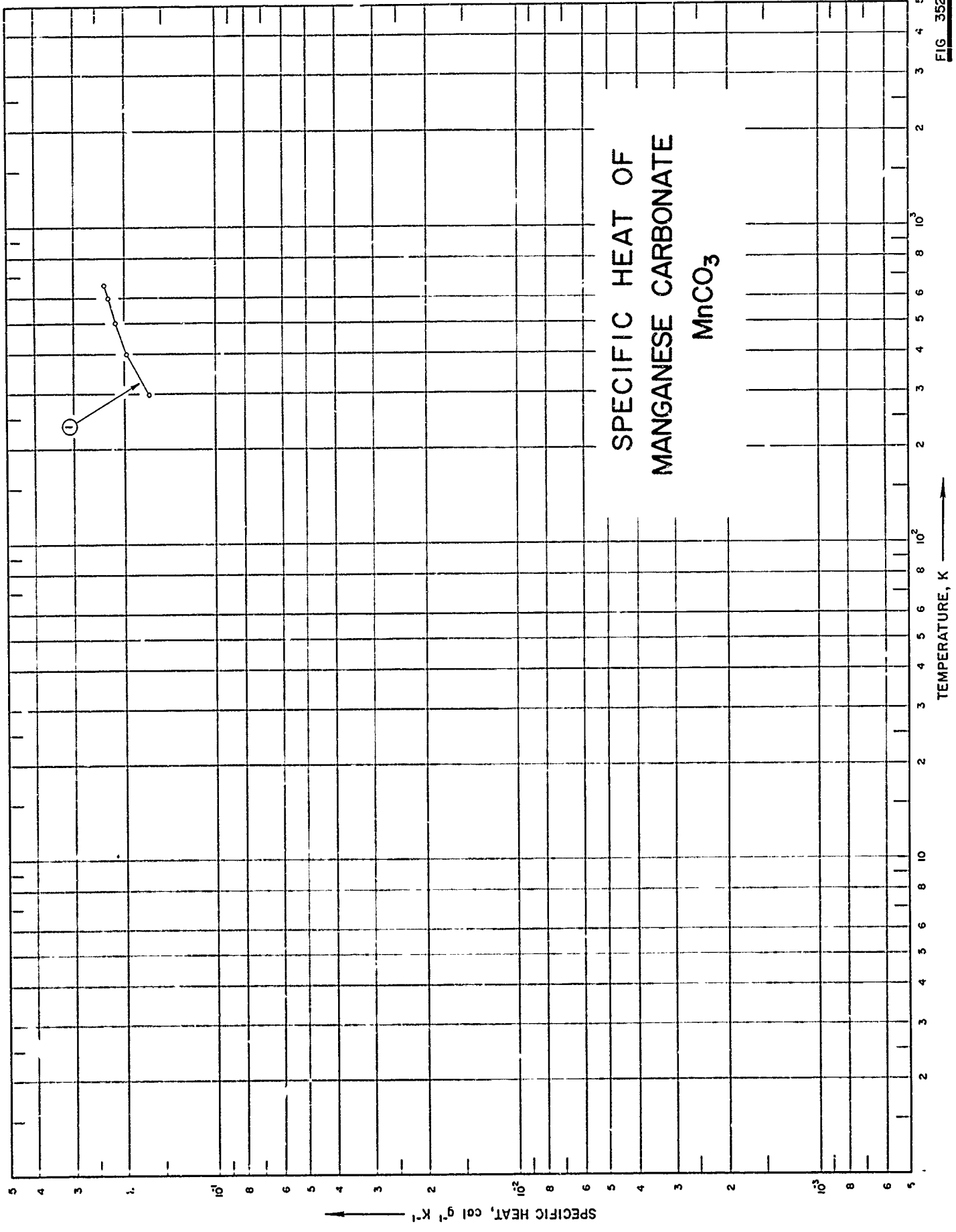

SPECIFIC HEAT, cal g⁻¹ K⁻¹ ↑

TEMPERATURE, K →

SPECIFICATION TABLE NO. 352 SPECIFIC HEAT OF MANGANESE CARBONATE, $MnCO_3$

[For Data Reported in Figure and Table No. 352]

Curve No.	Ref. No.	Year	Temp. Range, K	Reported Error, %	Name and Specimen Designation	Composition (weight percent), Specifications and Remarks
1	101	1943	298-660		Rhodochrosite	2.0 $CaCO_3$, 0.1 SiO_2 , and 0.1 $FeCO_3$; corrected for impurities.

DATA TABLE NO. 352 SPECIFIC HEAT OF MANGANESE CARBONATE, $MnCO_3$
[Temperature, T, K; Specific Heat, C_p , $Cal\ g^{-1}K^{-1}$]

T	C_p
<u>CURVE 1</u>	
298.15	1.670×10^{-1}
300	1.678*
400	1.984
500	2.161
600	2.287
660	2.351

* Not shown on plot

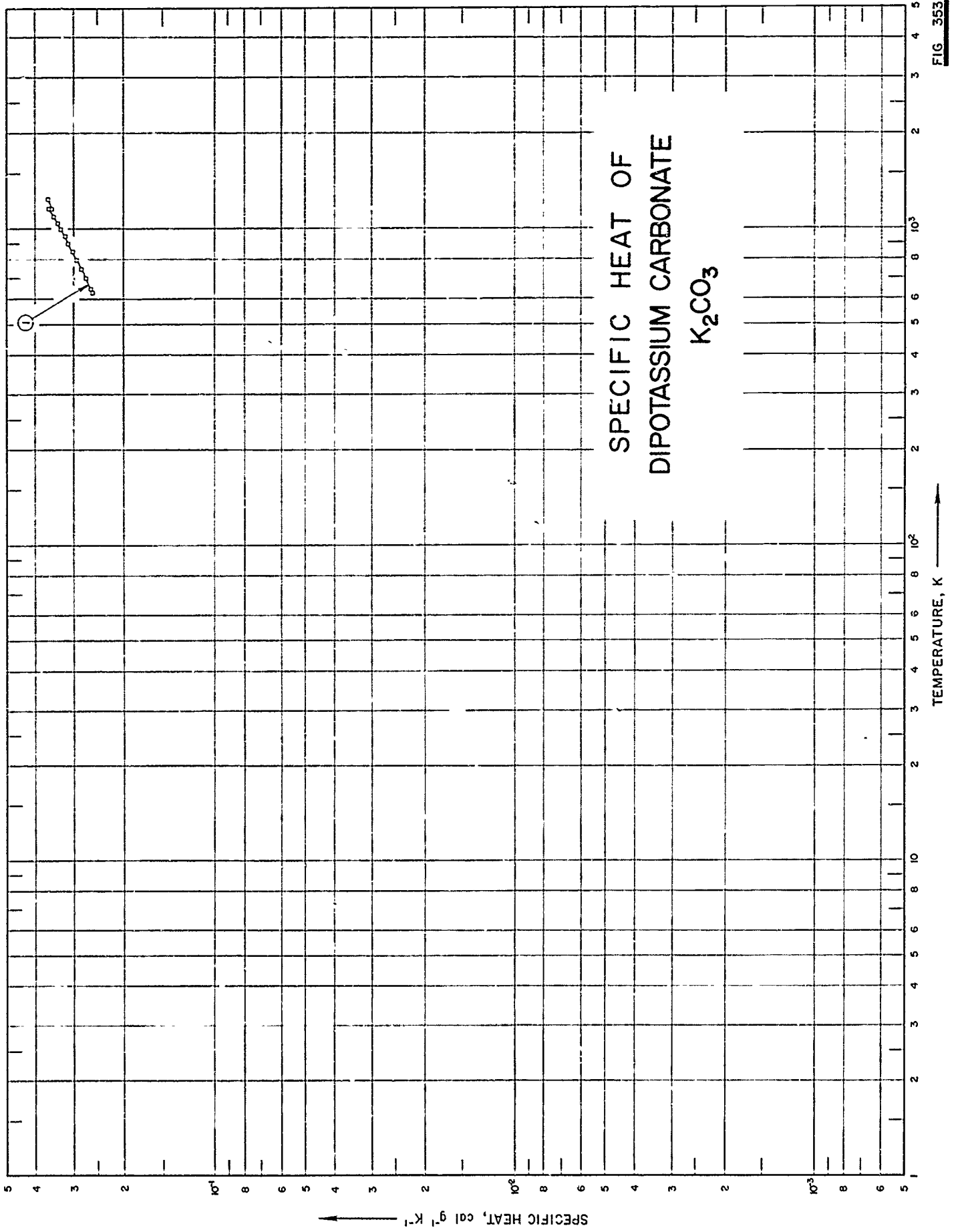

FIG. 353

SPECIFICATION TABLE NO. 353 SPECIFIC HEAT OF DIPOTIASSIUM CARBONATE, K_2CO_3

[For Data Reported in Figure and Table No. 353]

Curve No.	Ref. No.	Year	Temp. Range, K	Reported Error, %	Name and Specimen Designation	Composition (weight percent), Specifications and Remarks
1	430	1963	630-1250			Baker reagents.

DATA TABLE NO. 353 SPECIFIC HEAT OF DIPOTASSIUM CARBONATE, K_2CO_3 [Temperature, T, K; Specific Heat, C_p , Cal $g^{-1}K^{-1}$]

T	C_p
	CURVE 1
630	2.576×10^{-1}
650	2.614
700	2.709
750	2.802
800	2.897
850	2.991
900	3.085
950	3.180
1000	3.274
1050	3.368
1100	3.463
1150	3.557*
(s)1169	3.593
(l)1169	3.574
1200	3.598*
1250	3.636

* Not shown on plot

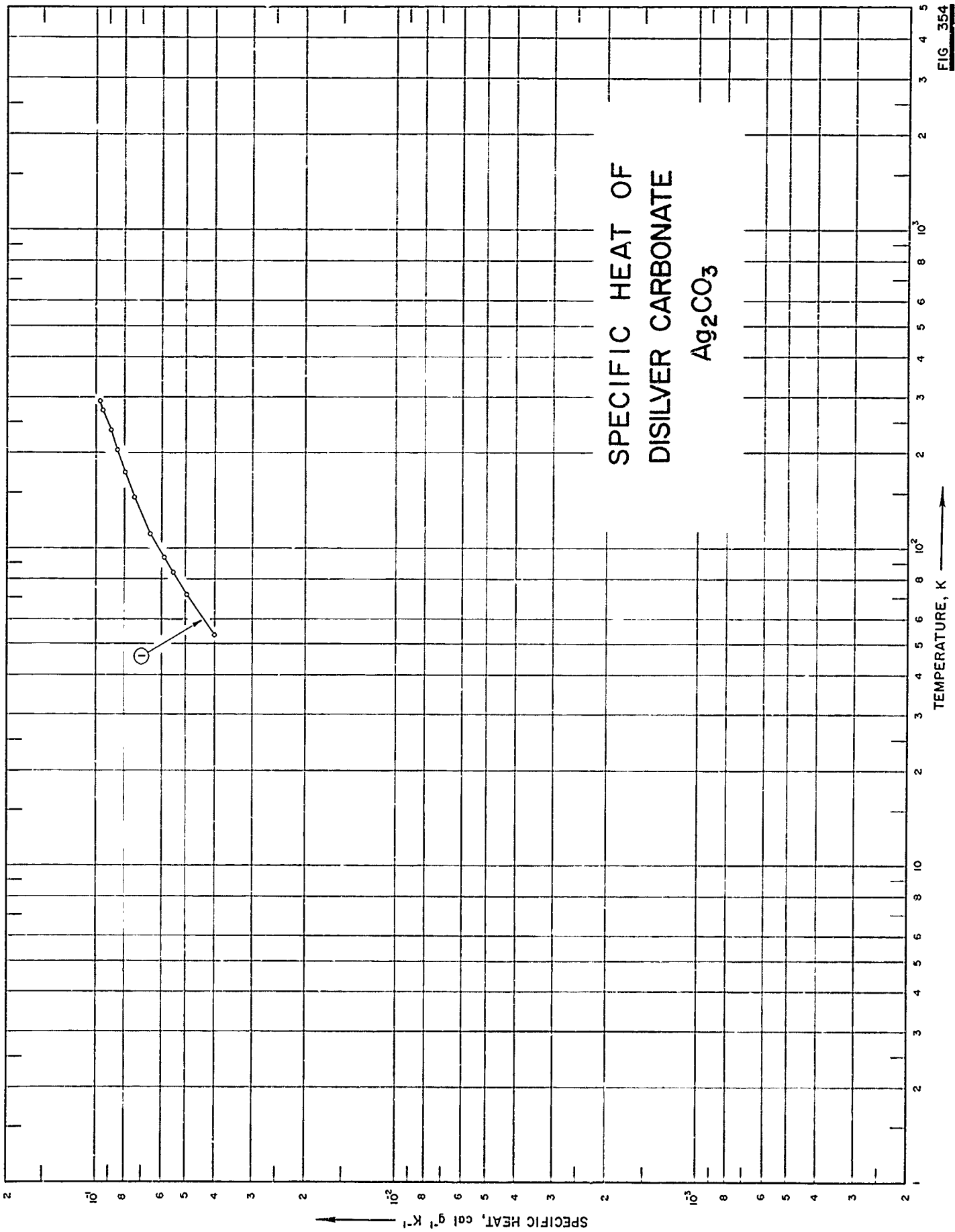

FIG. 354

SPECIFICATION TABLE NO. 354 SPECIFIC HEAT OF DISILVER CARBONATE, Ag_2CO_3

[For Data Reported in Figure and Table No. 354]

Curve No.	Ref. No.	Year	Temp. Range, K	Reported Error, %	Name and Specimen Designation	Composition (weight percent), Specifications and Remarks
1	431	1933	54-290			99.96 Ag_2CO_3 ; prepared from pure Ag foil and C. P. HNO_3 (recrystallized several times).

DATA TABLE NO. 354 SPECIFIC HEAT OF DISILVER CARBONATE, Ag_2CO_3
 [Temperature, T, K; Specific Heat, C_p , Cal $\text{g}^{-1}\text{K}^{-1}$]

T	C_p
<u>CURVE 1</u>	
53.51	4.011×10^{-2}
54.46	4.025*
71.57	4.972
84.25	5.534
93.53	5.904
93.57	5.904*
112.0	6.571
113.7	6.618
145.2	7.441
173.9	7.989
204.2	8.482
237.4	8.939
272.9	9.487
283.7	9.610
290.4	9.653

* Not shown on plot

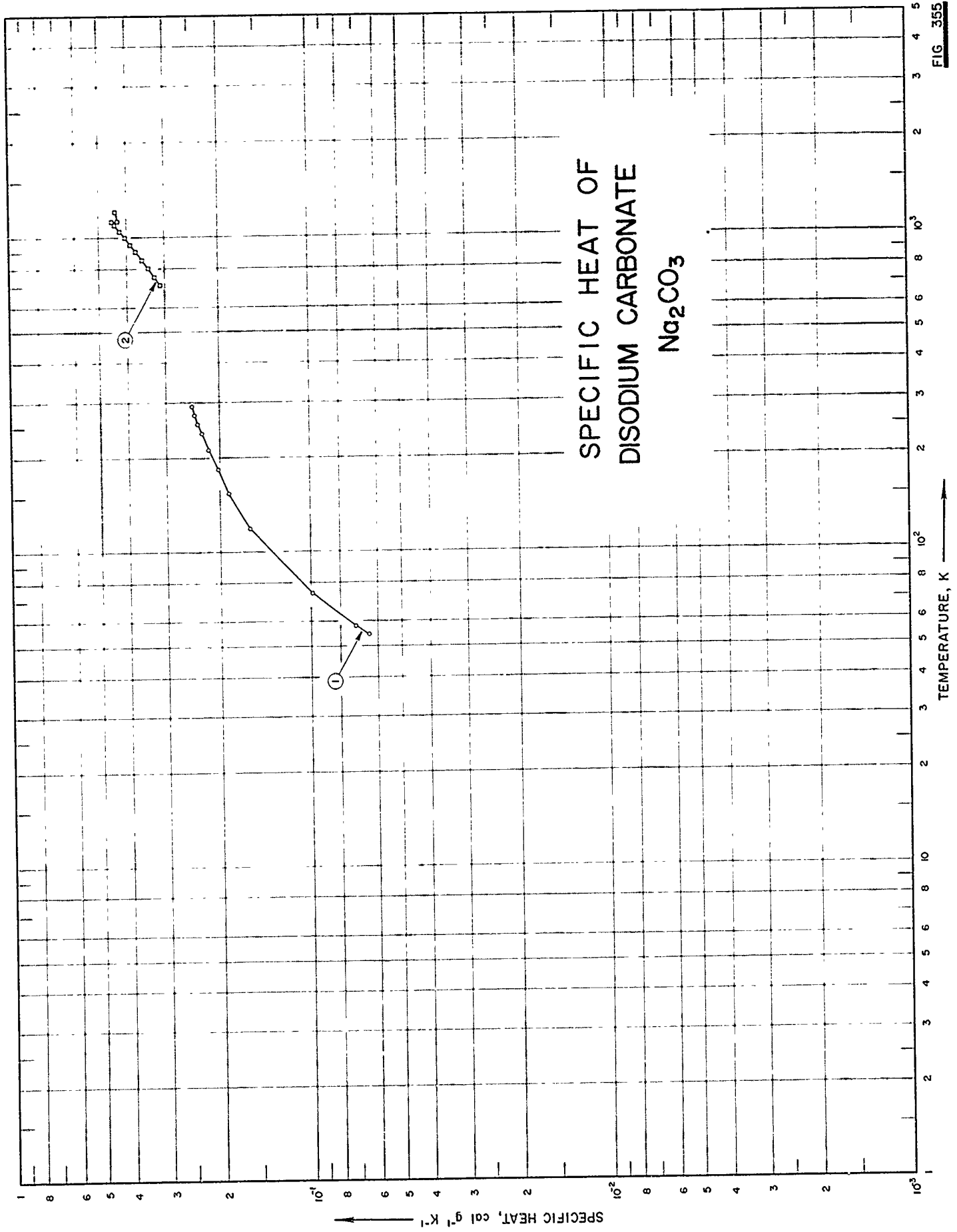

FIG. 355

SPECIFICATION TABLE NO. 355 SPECIFIC HEAT OF DISODIUM CARBONATE, Na_2CO_3

[For Data Reported in Figure and Table No. 355]

Curve No.	Ref. No.	Year	Temp. Range, K	Reported Error, %	Name and Specimen Designation	Composition (weight percent), Specifications and Remarks
1	431	1933	55-289			Merck anhydrous C.P.; < 0.1 total impurities; hydrogen atmosphere.
2	430	1963	707-1210			Baker analyzed reagents.

DATA TABLE NO. 355 SPECIFIC HEAT OF DISODIUM CARBONATE, Na_2CO_3 [Temperature, T, K; Specific Heat, C_p , Cal $\text{g}^{-1}\text{K}^{-1}$]

T	C_p
<u>CURVE 1</u>	
54.60	6.489×10^{-2}
58.43	7.151
74.23	9.935
119.2	1.600
154.6	1.876
183.6	2.034
212.6	2.155
239.7	2.305
256.7	2.370
292.1	2.480
274.1	2.435
280.2	2.454*
289.3	2.476*
<u>CURVE 2</u>	
707	3.123
750	3.266
800	3.432
850	3.599
900	3.766
950	3.932
1000	4.099
1050	4.268
1100	4.432
(s)1127	4.521
(c)1127	4.345
1150	4.369*
1200	4.419*
1210	4.429

* Not shown on plot

FIG. 356

SPECIFIC HEAT OF
SODIUM BICARBONATE
NaHCO₃

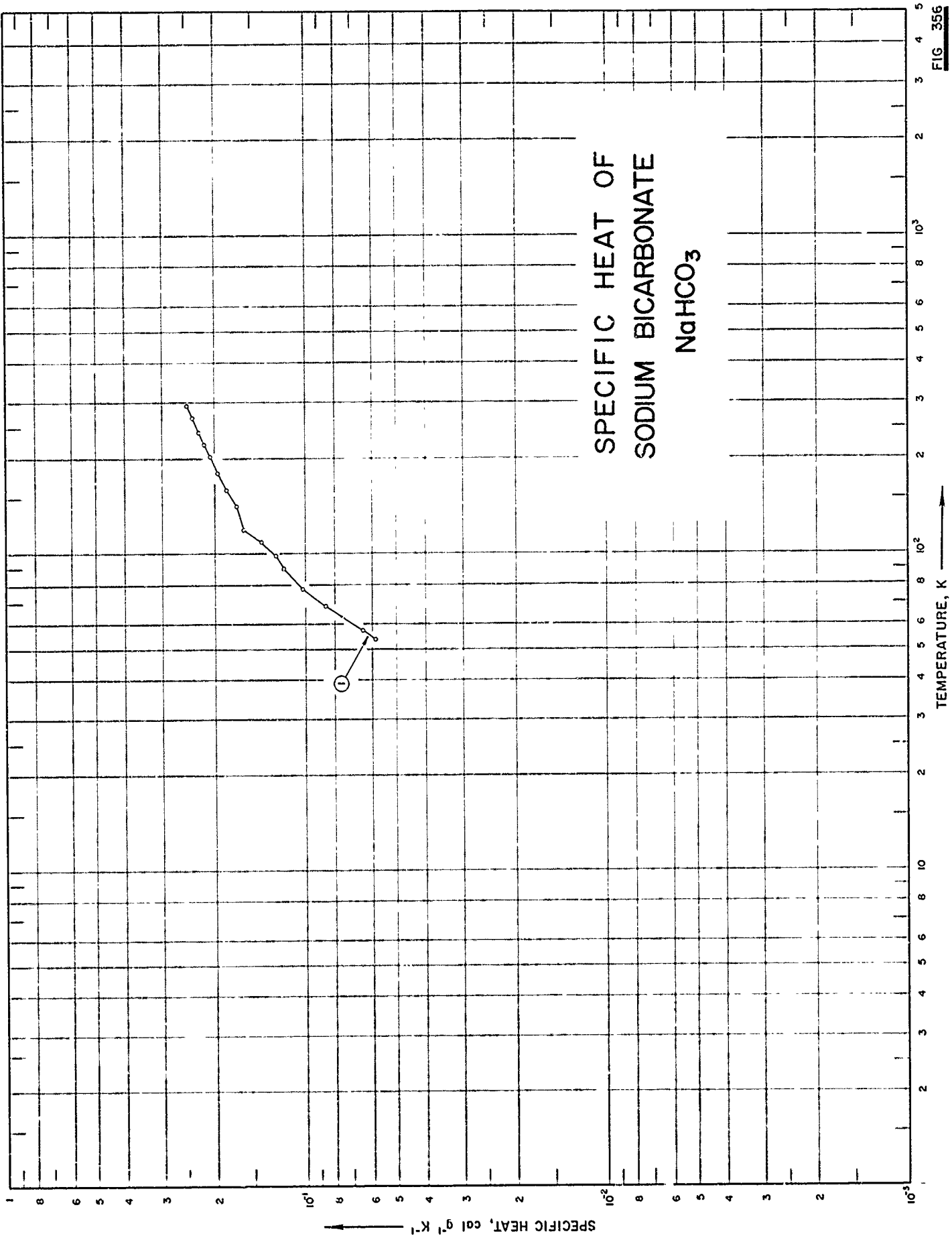

SPECIFICATION TABLE NO. 356 SPECIFIC HEAT OF SODIUM BICARBONATE, NaHCO_3

[For Data Reported in Figure and Table No. 356]

Curve No.	Ref. No.	Year	Temp. Range, K	Reported Error, %	Name and Specimen Designation	Composition (weight percent), Specifications and Remarks
1	431	1933	54-295			> 99.8 NaHCO_3 , 0.1 H_2O , and 0.1 Na_2CO_3 ; sample supplied by Squibb.

DATA TABLE NO. 356 SPECIFIC HEAT OF SODIUM BICARBONATE, NaHCO_3 [Temperature, T, K; Specific Heat, C_p , Cal $\text{g}^{-1}\text{K}^{-1}$]

T	C_p
<u>CURVE 1</u>	
54.17	5.860×10^{-2}
57.54	6.473
68.65	8.601
77.86	1.023×10^{-1}
90.07	1.185
99.07	1.258
109.4	1.417
129.8	1.619
142.0	1.700
159.4	1.830
182.3	1.959
203.4	2.077
221.8	2.172
240.6	2.262
270.7	2.388
291.8	2.475 ^a
295.1	2.487

^a Not shown on plot

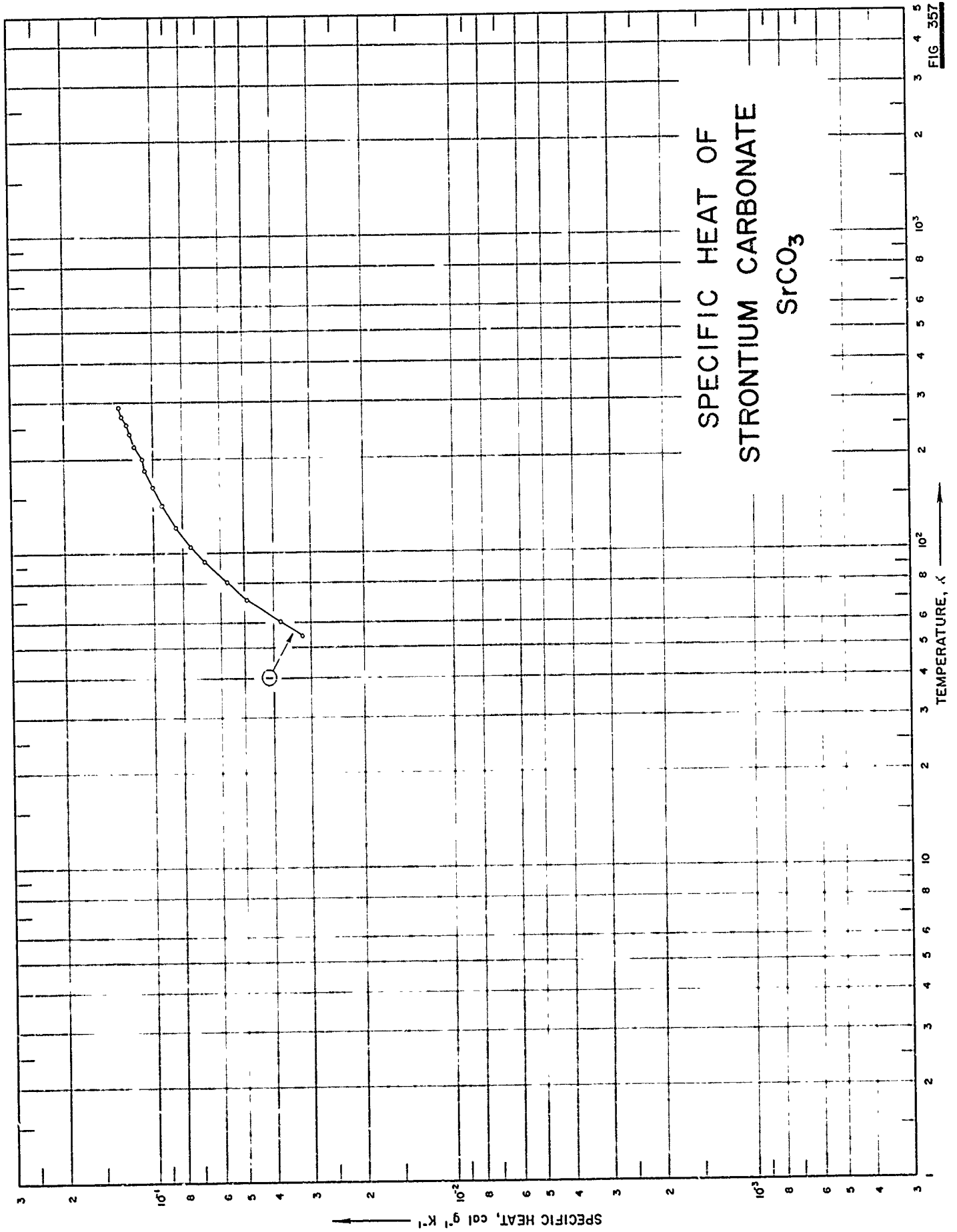

SPECIFICATION TABLE NO. 357 SPECIFIC HEAT OF STRONTIUM CARBONATE, SrCO₃

[For Data Reported in Figure and Table No. 357]

Curve No.	Ref. No.	Year	Temp. Range, K	Reported Error, %	Name and Specimen Designation	Composition (weight percent), Specifications and Remarks
1	427	1934	55-291		Strontianite	93.0 SrCO ₃ and 7.0 CaCO ₃ ; corrected for impurities.
2	42	1951	455-1186			Exceptionally high purity.

DATA TABLE NO. 357 SPECIFIC HEAT OF STRONTIUM CARBONATE, SrCO_3
 [Temperature, T, K; Specific Heat, C_p , Cal g⁻¹K⁻¹]

T	C_p	
	CURVE 1	CURVE 2
54.7	3.221×10^{-2}	
60.5	3.791	
71.2	4.917	
80.8	5.721	
94.2	6.774	
105.4	7.533	
121.3	8.420	
142.3	9.369	
162.6	1.009×10^{-1}	
184.0	1.073	
200.4	1.088	
218.8	1.162	
240.6	1.209	
257.6	1.229	
272.3	1.280	
291.2	1.307	
455		1.603
500		1.649
600		1.735
700		1.810
800		1.879
900		1.945
1000		2.008
1100		2.070
1186		2.122

SPECIFIC HEAT OF
BARIUM DINITRATE
 $Ba(NO_3)_2$

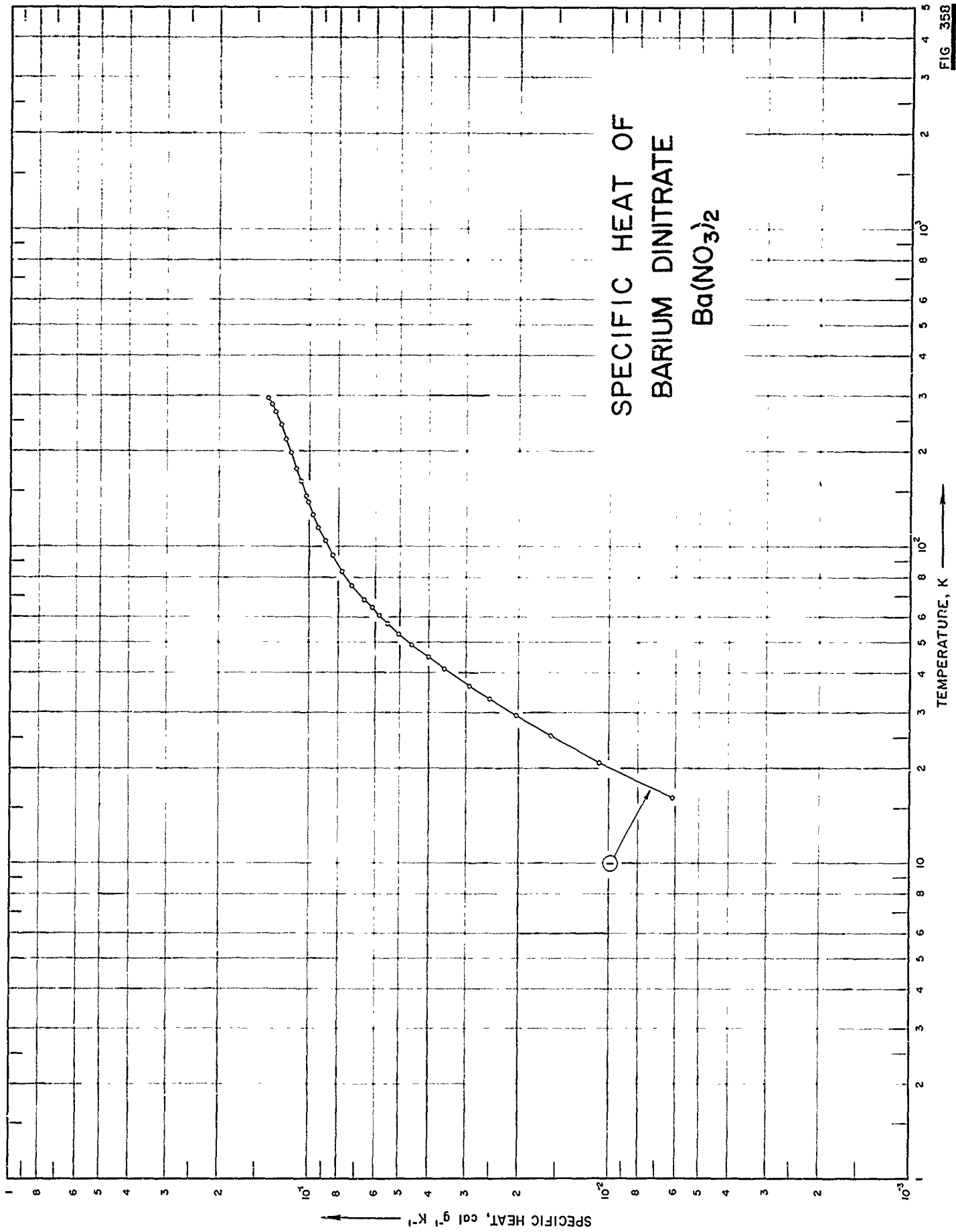

SPECIFICATION TABLE NO. 358 SPECIFIC HEAT OF BARIUM DINITRATE, $\text{Ba}(\text{NO}_3)_2$

[For Data Reported in Figure and Table No. 358]

Curve No.	Ref. No.	Year	Temp. Range, K	Reported Error, %	Name and Specimen Designation	Composition (weight percent), Specifications and Remarks
1	432	1930	16-296			

DATA TABLE NO. 358 SPECIFIC HEAT OF BARIUM DINITRATE, $\text{Ba}(\text{NO}_3)_2$ [Temperature, T, K; Specific Heat, C_p , Cal $\text{g}^{-1}\text{K}^{-1}$]

T	C_p	T	C_p
<u>CURVE 1</u>		<u>CURVE 1 (cont.)</u>	
16.2	6.159×10^{-3}	281.79	1.354×10^{-1}
20.84	1.081×10^{-2}	289.53	1.377
25.26	1.570	295.73	1.384
29.39	2.043		
33.14	2.517		
36.25	2.934		
41.22	3.564		
44.95	4.036		
49.06	4.595		
53.00	5.058		
57.43	5.536		
60.68	5.865		
64.45	6.236		
68.28	6.622		
71.64	6.894*		
75.45	7.265		
79.15	7.529*		
83.75	7.816		
89.10	8.145*		
94.03	8.424		
99.13	8.673*		
104.20	8.883		
109.75	9.143*		
115.25	9.350		
121.05	9.622*		
127.09	9.832		
132.77	9.947*		
138.60	1.016×10^{-1}		
145.02	1.033		
161.43	1.077		
168.66	1.094*		
176.15	1.111		
183.70	1.132*		
198.05	1.165		
205.48	1.183*		
212.24	1.197*		
219.00	1.216		
226.26	1.224*		
233.17	1.239*		
242.66	1.259		
250.09	1.284*		
258.08	1.302*		
265.93	1.315		
273.87	1.349*		

* Not shown on plot

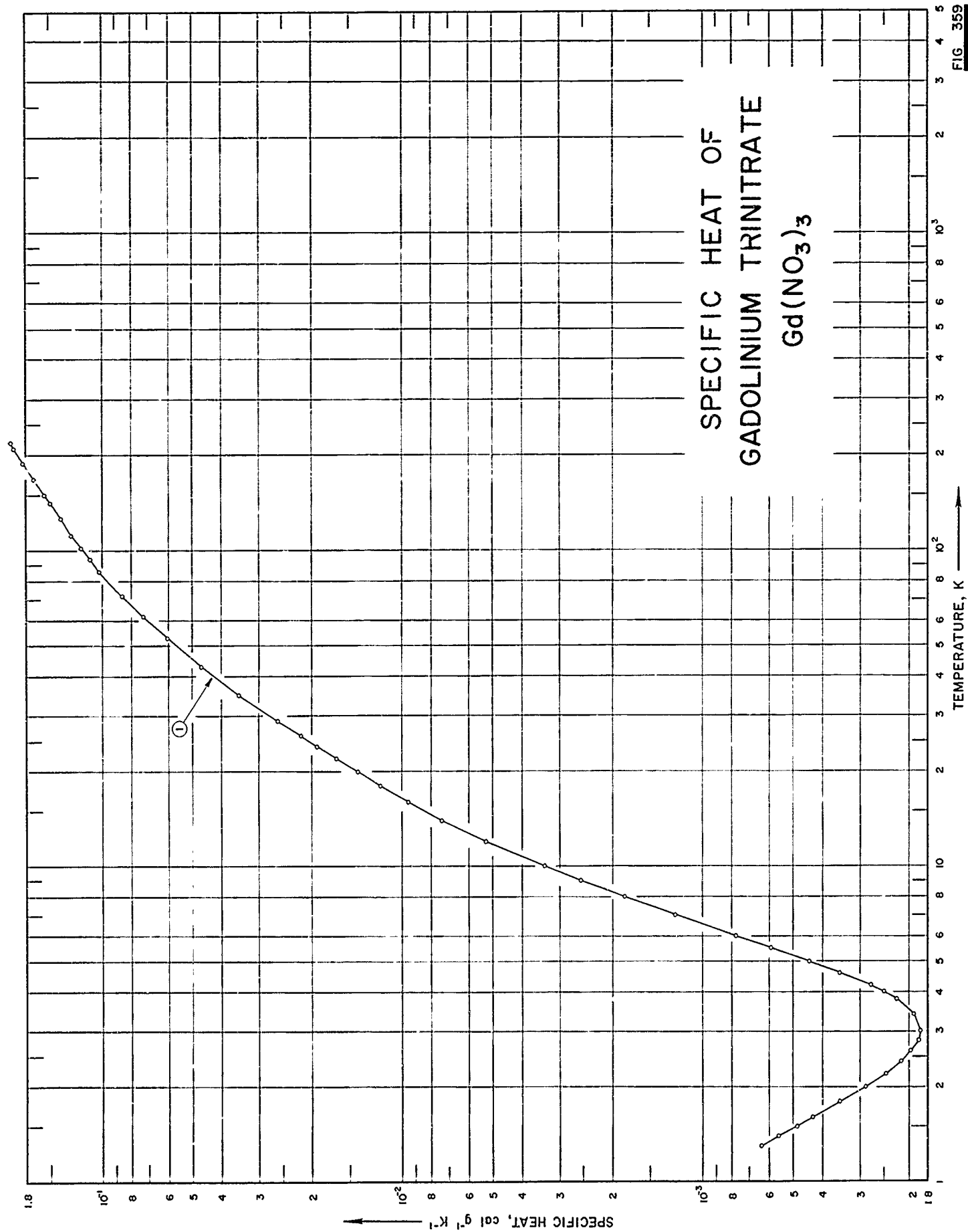

SPECIFICATION TABLE NO. 359 SPECIFIC HEAT OF GADOLINIUM TRINITRATE HEXAHYDRATE, $Gd(NO_3)_3 \cdot 6H_2O$

[For Data Reported in Figure and Table No. 359]

Curve No.	Ref. No.	Year	Temp. Range, K	Reported Error, %	Name and Specimen Designation	Composition (weight percent), Specifications and Remarks
1	433	1962	1.3-230			

DATA TABLE NO. 359 SPECIFIC HEAT OF GADOLINIUM TRINITRITE HEXAHYDRATE, $Gd(NO_2)_3 \cdot 6H_2O$ [Temperature, T, K; Specific Heat, C_p , Cal $g^{-1} K^{-1}$]

T	CURVE 1	
	C_p	T
1.3	6.41×10^{-4}	168.0
1.4	5.61	189.0
1.5	4.86	210.0
1.6	4.30	220.0
1.8	3.52	
2.0	2.87	
2.2	2.46	
2.4	2.20	
2.6	2.03	
2.8	1.92	
3.0	1.89	
3.4	1.99	
3.8	2.27	
4.0	2.49	
4.2	2.76	
4.6	3.51	
5.0	4.43	
5.5	5.947	
6.0	7.768	
7.0	1.235×10^{-3}	
8.0	1.823	
9.0	2.555	
10.0	3.385	
12.0	5.301	
14.0	7.419	
16.0	9.606	
18.0	1.181×10^{-2}	
20.0	1.414	
22.0	1.661	
24.0	1.922	
26.0	2.189	
29.0	2.614	
35.0	3.516	
43.0	4.672	
53.0	6.052	
62.0	7.297	
72.0	8.626	
86.0	1.025×10^{-1}	
94.0	1.105	
102.0	1.178	
112.0	1.270	
127.0	1.389	
141.0	1.499	
150.0	1.571	

CURVE 1 (cont.)

C_p
1.702 x 10⁻¹
1.851
1.985
2.041

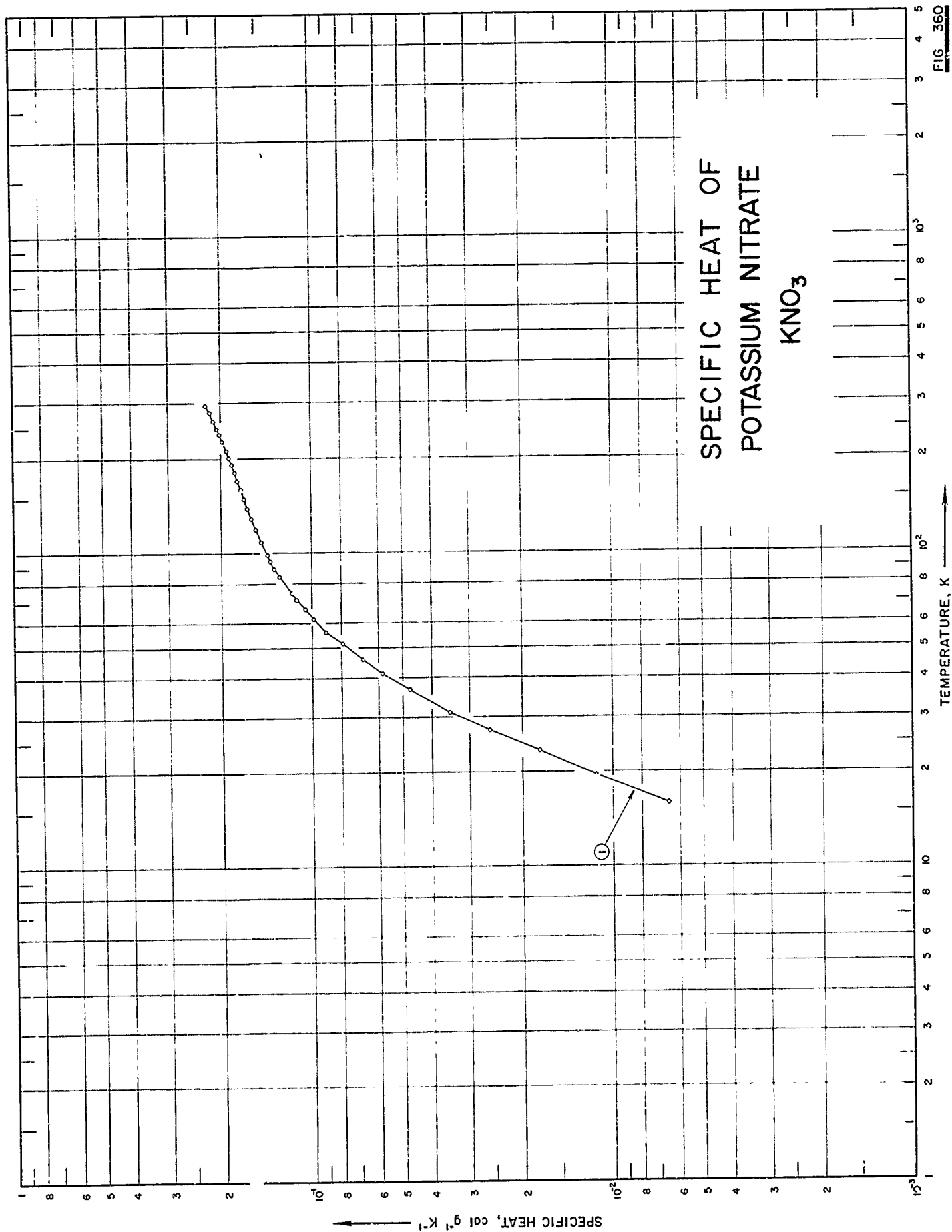

SPECIFICATION TABLE NO. 360 SPECIFIC HEAT OF POTASSIUM NITRATE, KNO_3

[For Data Reported in Figure and Table No. 360]

Curve No.	Ref. No.	Year	Temp. Range, K	Reported Error, %	Name and Specimen Designation	Composition (weight percent), Specifications and Remarks
1	266	1933	16-296			C.P. quality further purified by 3 or 4 recrystallizations; dried in high vacuum.

DATA TABLE NO. 360 SPECIFIC HEAT OF POTASSIUM NITRATE, KNO_3 [Temperature, T, K; Specific Heat, C_p , Cal $\text{g}^{-1}\text{K}^{-1}$]

T	C_p		T	C_p	
	CURVE 1	10^{-3}		CURVE 1 (cont.)	10^{+4}
15.96	6.567	10^{-3}	196.53	1.872	10^{+4} *
19.52	1.146	10^{-2}	201.37	1.893	
23.45	1.767		201.79	1.891*	
27.28	2.572		206.62	1.911*	
27.41	2.655*		207.03	1.915*	
31.07	3.513		211.87	1.934*	
36.78	4.755		212.27	1.934	
41.37	5.863		217.11	1.952*	
46.20	6.810		222.34	1.977*	
51.57	7.981		227.56	1.992	
56.86	9.059		233.04	2.017*	
61.79	9.940		238.53	2.029*	
66.43	1.064	10^{-1}	238.90	2.035	
71.16	1.129		243.75	2.051*	
74.84	1.172		244.12	2.050*	
84.24	1.294		248.96	2.074*	
89.15	1.340*		249.33	2.074	
89.20	1.343		254.53	2.090*	
93.95	1.380*		259.73	2.114*	
94.01	1.382		264.93	2.129	
98.68	1.417		270.11	2.160*	
98.74	1.416*		275.29	2.171*	
103.38	1.455*		280.46	2.195	
108.22	1.487		285.63	2.216*	
113.30	1.514*		290.78	2.245*	
118.31	1.548		295.92	2.268	
123.26	1.574*				
128.17	1.598				
133.31	1.627*				
138.69	1.652				
143.63	1.674*				
144.04	1.678*				
148.98	1.688				
149.36	1.699*				
154.30	1.719*				
154.68	1.714*				
159.62	1.735				
164.93	1.757*				
170.22	1.770				
175.49	1.797*				
180.76	1.813				
186.03	1.834*				
191.28	1.860				
196.12	1.875*				

* Not shown on plot

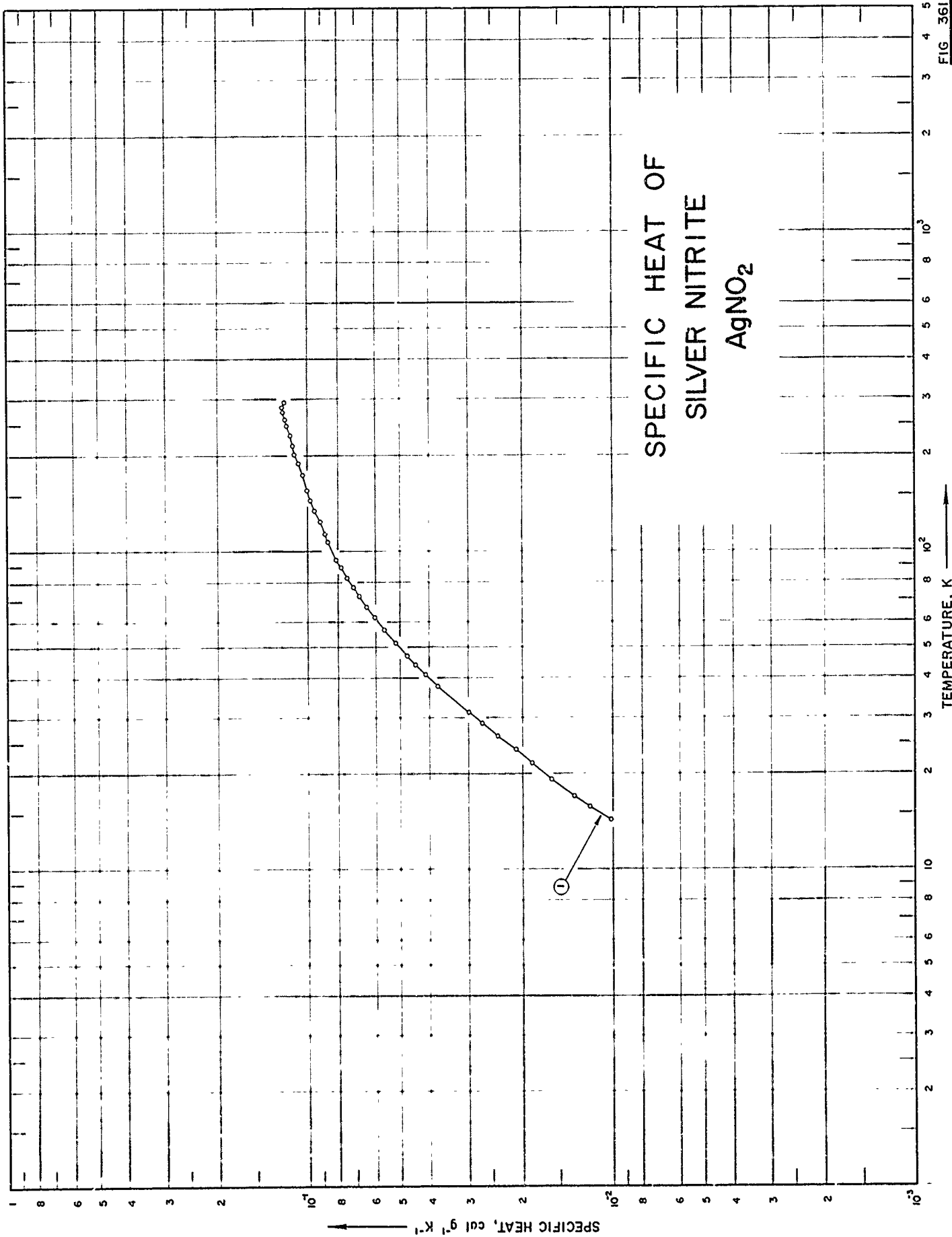

FIG 36I

SPECIFICATION TABLE NO. 361 SPECIFIC HEAT OF SILVER NITRITE, AgNO_2

[For Data Reported in Figure and Table No. 361]

Curve No.	Ref. No.	Year	Temp. Range, K	Reported Error, %	Name and Specimen Designation	Composition (weight percent), Specifications and Remarks
1	434	1937	14-295			69.925 Ag and 29.765 NO_2 (70.10 Ag, 29.96 NO_2 theo); C. P. sample; recrystallized from distilled water and dried in a vacuum desiccator for several days.

DATA TABLE NO. 361 SPECIFIC HEAT OF SILVER NITRITE, AgNO_2
 [Temperature, T, K; Specific Heat, Cp, Cal $\text{g}^{-1}\text{K}^{-1}$]

T	CURVE 1		T	CURVE 1 (cont.)	
	Cp	1.014×10^{-2}		Cp	1.226×10^{-2}
14.36	1.014	1.014×10^{-2}	265.92	1.226	1.226×10^{-2}
15.77	1.189		273.93	1.224*	
17.09	1.345		274.16	1.226	
19.21	1.599		284.13	1.232	
21.65	1.852		284.30	1.224*	
23.84	2.093		294.94	1.213	
26.32	2.418				
28.82	2.710				
31.24	2.989				
37.72	3.789				
41.04	4.159				
44.15	4.471				
47.40	4.777				
51.67	5.212				
56.73	5.693				
62.21	6.111				
67.37	6.499				
72.32	6.876				
77.10	7.176				
82.86	7.532				
89.26	7.863				
94.07	8.162				
107.35	8.708				
113.53	8.916				
124.51	9.241				
129.71	9.449*				
140.48	9.833*				
145.93	9.950				
151.31	1.008×10^{-2}				
156.59	1.019				
156.60	1.019*				
163.45	1.025*				
174.86	1.055				
189.00	1.090				
195.94	1.107*				
202.25	1.124				
215.27	1.139				
223.49	1.148*				
232.36	1.164				
240.05	4.180*				
248.24	1.192				
255.45	1.205*				
260.44	1.207				

* Not shown on plot

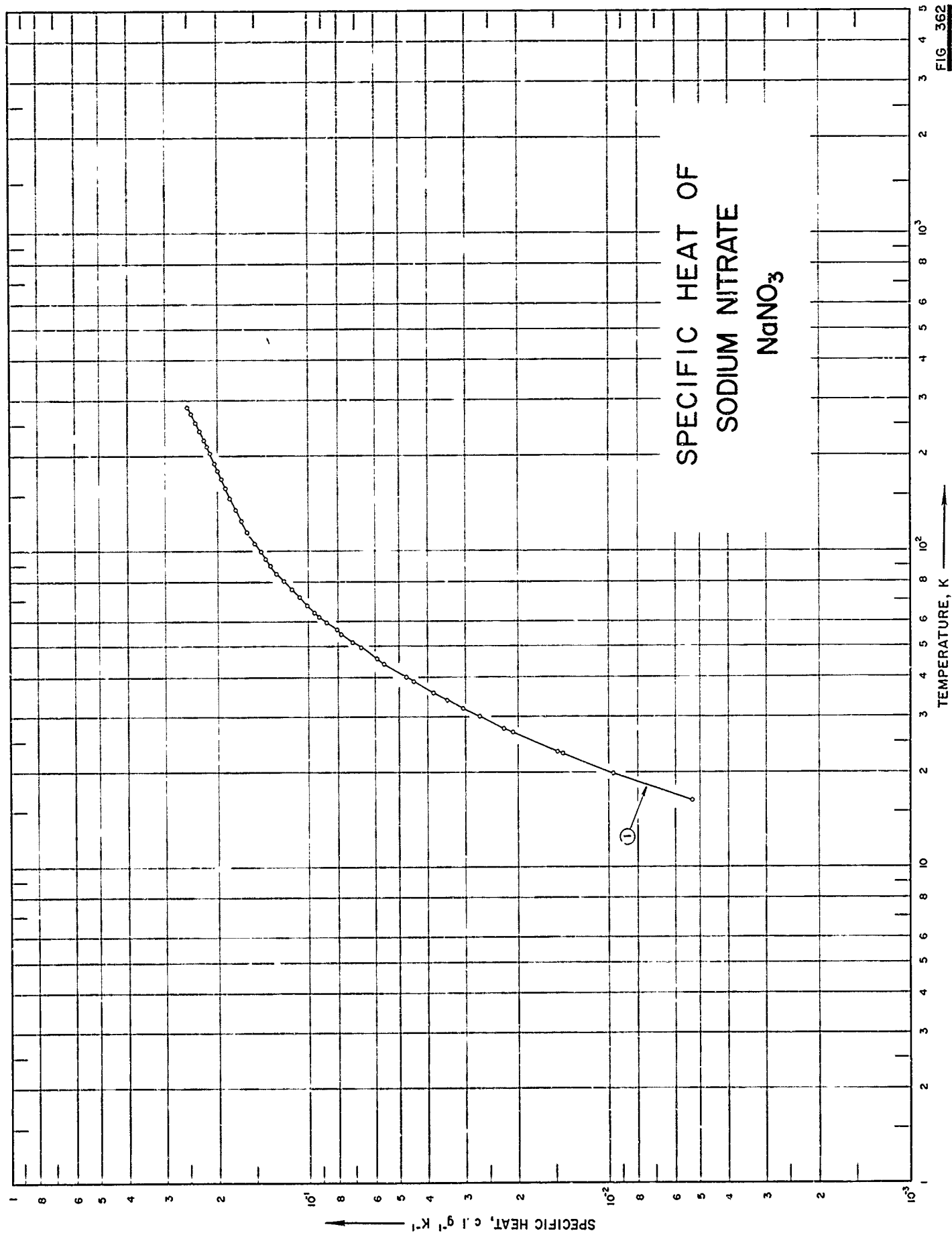

SPECIFICATION TABLE NO. 362 SPECIFIC HEAT OF SODIUM NITRATE, NaNO_3

[For Data Reported in Figure and Table No. 362]

Curve No.	Ref. No.	Year	Temp. Range, K	Reported Error, %	Name and Specimen Designation	Composition (weight percent), Specifications and Remarks
1	266	1933	16-287			C. P. quality further purified by 3 or 4 recrystallizations; dried in high vacuum.

DATA TABLE NO. 362 SPECIFIC HEAT OF SODIUM NITRATE, NaNO_3
 [Temperature, T, K; Specific Heat, C_p , Cal $\text{g}^{-1} \text{K}^{-1}$]

T	C_p		T	C_p
	CURVE 1	CURVE 1 (cont.)		
16.23	5.341×10^{-3}	1.911×10^{-1}	158.30	
19.78	9.730	1.944*	163.59	
22.92	1.438×10^{-2}	1.952*	164.48	
23.29	1.498	1.967*	168.85	
26.78	2.100	1.969	169.20	
27.56	2.267	1.995*	174.09	
30.03	2.720	1.997*	174.90	
31.84	3.090	2.025	180.09	
33.85	3.499	2.053*	185.25	
35.63	3.858	2.077	190.39	
38.80	4.525	2.148	204.86	
40.08	4.775	2.164*	207.61	
44.35	5.653	2.173*	209.95	
45.90	5.971	2.204*	214.99	
49.73	6.767	2.205	215.02	
51.57	7.227	2.226*	220.06	
54.91	7.869	2.225*	220.08	
56.99	8.143	2.251	225.13	
59.64	8.787	2.274*	230.18	
62.37	9.280	2.300*	235.21	
64.40	9.644	2.326	240.24	
67.32	1.020×10^{-1} *	2.362*	245.25	
67.67	1.023	2.358*	247.21	
71.90	1.088*	2.374*	250.25	
71.94	1.087	2.407	255.45	
76.22	1.158	2.414*	258.16	
80.61	1.224	2.428*	260.65	
85.37	1.299	2.438*	263.04	
90.20	1.352	2.471*	267.91	
91.42	1.360*	2.488	272.77	
94.87	1.408	2.514*	277.23	
98.60	1.426*	2.512*	277.62	
99.42	1.455	2.539*	282.06	
101.61	1.477*	2.537*	282.47	
106.51	1.525	2.562	286.86	
111.30	1.568*			
116.00	1.611			
120.62	1.653*			
125.72	1.699			
131.29	1.734*			
136.79	1.764			
142.24	1.804*			
147.63	1.849			
152.98	1.880*			

* Not shown on plot

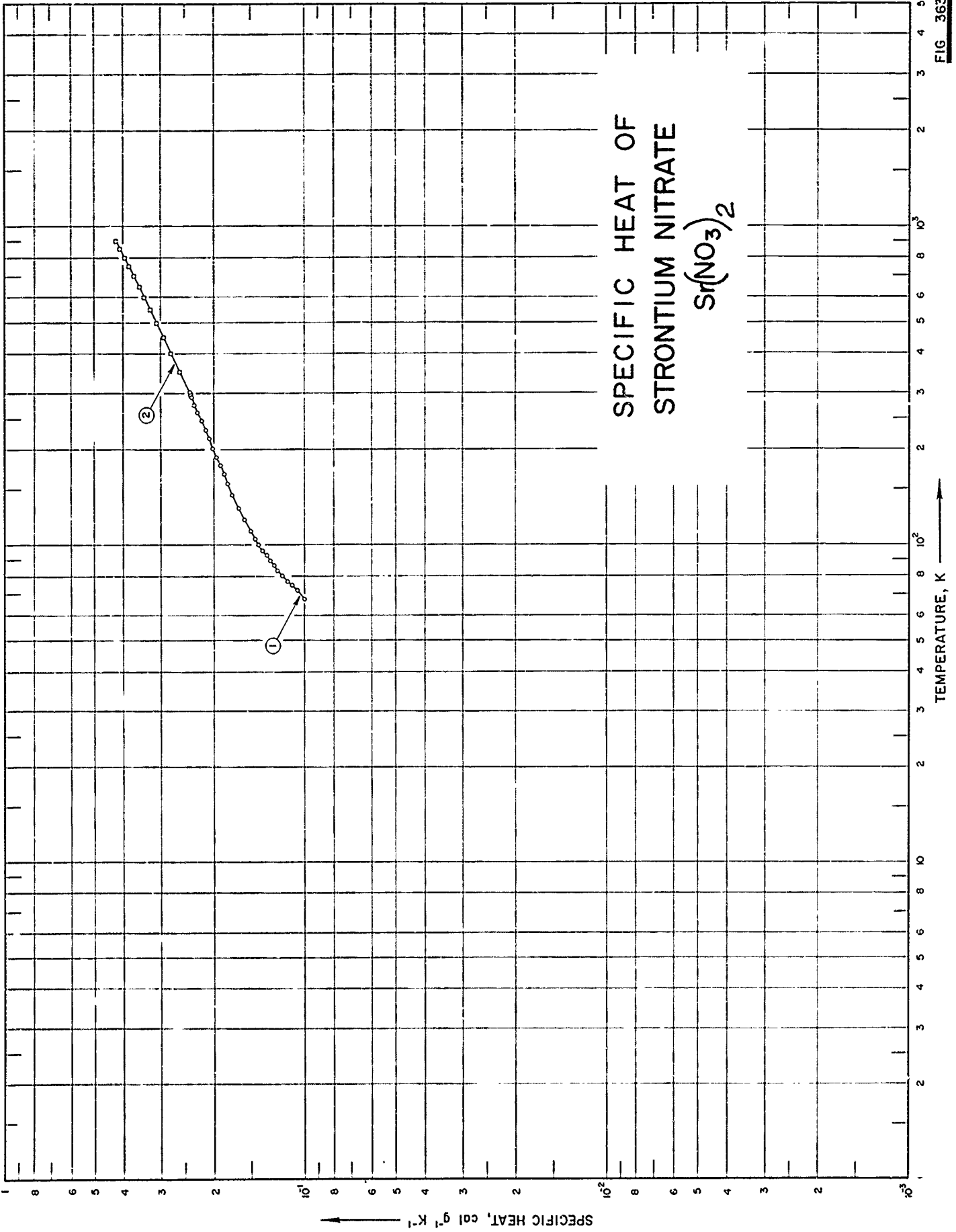

FIG 363

SPECIFICATION TABLE NO. 363 SPECIFIC HEAT OF STRONTIUM NITRATE, $\text{Sr}(\text{NO}_3)_2$

[For Data Reported in Figure and Table No. 363]

Curve No.	Ref. No.	Year	Temp. Range, K	Reported Error, %	Name and Specimen Designation	Composition (weight percent), Specifications and Remarks
1	315	1962	68-304			Reagent grade; dried 4 hrs at 200 C.
2	315	1962	298-900			Same as above.

DATA TABLE NO. 363 SPECIFIC HEAT OF STRONTIUM NITRATE, $S(\text{NO}_3)_2$
 [Temperature, T, K; Specific Heat, C_p , Cal $\text{g}^{-1}\text{K}^{-1}$]

T	C_p	CURVE 1	
		CURVE 1	C_p
67.97	1.004×10^{-1}		
72.34	1.067	255.77	2.254×10^{-2} *
75.16	1.101	259.06	2.264*
77.85	1.146	262.03	2.277
80.69	1.192	264.98	2.287*
83.68	1.234	267.48	2.300*
86.57	1.267	273.65	2.322*
89.60	1.307	276.63	2.324
92.81	1.343	280.59	2.335*
95.28	1.381	288.22	2.361*
100.59	1.425	292.21	2.378
102.14	1.447*	296.02	2.391*
105.40	1.464	299.79	2.398*
108.91	1.497*	303.54	2.410
111.09	1.514		
115.65	1.557*		
120.20	1.588		
124.64	1.618*		
131.32	1.663		
139.47	1.714*		
144.23	1.742		
153.53	1.792*		
156.22	1.808		
162.18	1.837*		
167.53	1.857		
172.07	1.879*		
178.68	1.917		
184.82	1.945*		
189.60	1.970		
193.40	1.984*		
198.16	2.006*		
202.37	2.023		
205.89	2.040*		
209.97	2.054*		
213.99	2.067*		
216.71	2.078		
222.30	2.098*		
227.12	2.119*		
230.18	2.134		
234.04	2.153*		
238.42	2.168*		
242.62	2.192*		
246.97	2.212		
250.88	2.230*		

T	C_p	CURVE 2	
		CURVE 2	C_p
298.15	2.392×10^{-1}		
300	2.400*		
350	2.605		
400	2.784		
450	2.949		
500	3.106		
550	3.256		
600	3.403		
650	3.546		
700	3.688		
750	3.828		
800	3.967		
850	4.105		
900	4.243		

* Not shown on plot

FIG. 364

SPECIFIC HEAT OF THALLIUM NITRATE TlNO₃

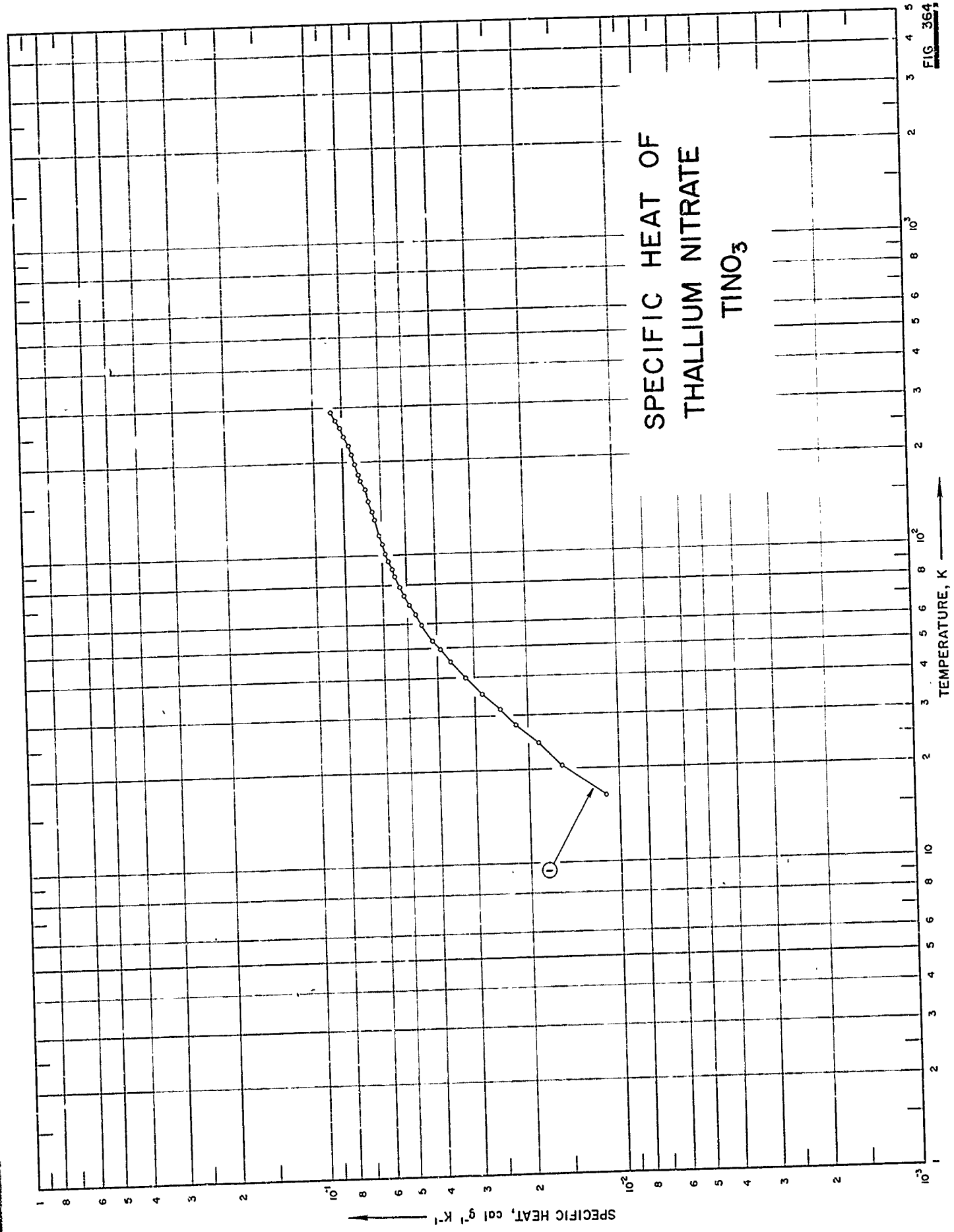

SPECIFICATION TABLE NO. 364 SPECIFIC HEAT OF THALLIUM NITRATE, $TlNO_3$

[For Data Reported in Figure and Table No. 364]

Curve No.	Ref. No.	Year	Temp. Range, K	Reported Error, %	Name and Specimen Designation	Composition (weight percent), Specifications and Remarks
1	436	1932	16-291	1-3		~ 100 $TlNO_3$.

DATA TABLE NO. 364 SPECIFIC HEAT OF THALLIUM NITRATE, TlNO_3
 [Temperature, T, K; Specific Heat, C_p , Cal $\text{g}^{-1} \text{K}^{-1}$]

T	C_p
<u>CURVE 1</u>	
16.45	1.113 x 10 ²
20.52	1.564
24.44	1.864
27.95	2.212
31.35	2.495
35.22	2.855
38.94	3.237
45.29	3.622
49.55	3.915
52.91	4.151
59.49	4.504
60.33	4.549*
64.51	4.744
69.19	4.968
74.22	5.157
79.34	5.330
85.54	5.510
90.02	5.619
95.90	5.765
101.71	5.882
108.68	6.032
116.98	6.163
130.25	6.392
137.92	6.497
149.85	6.670
162.78	6.828
174.79	7.064
182.43	7.165
197.32	7.353
211.64	7.541
226.53	7.740
242.59	7.987
250.52	8.119*
258.40	8.224
265.25	8.335*
272.38	8.483
281.69	8.599*
290.60	8.794

* Not shown on plot

FIG. 365

SPECIFIC HEAT OF
DIALUMINUM TRISULFATE
 $Al_2(SO_4)_3$

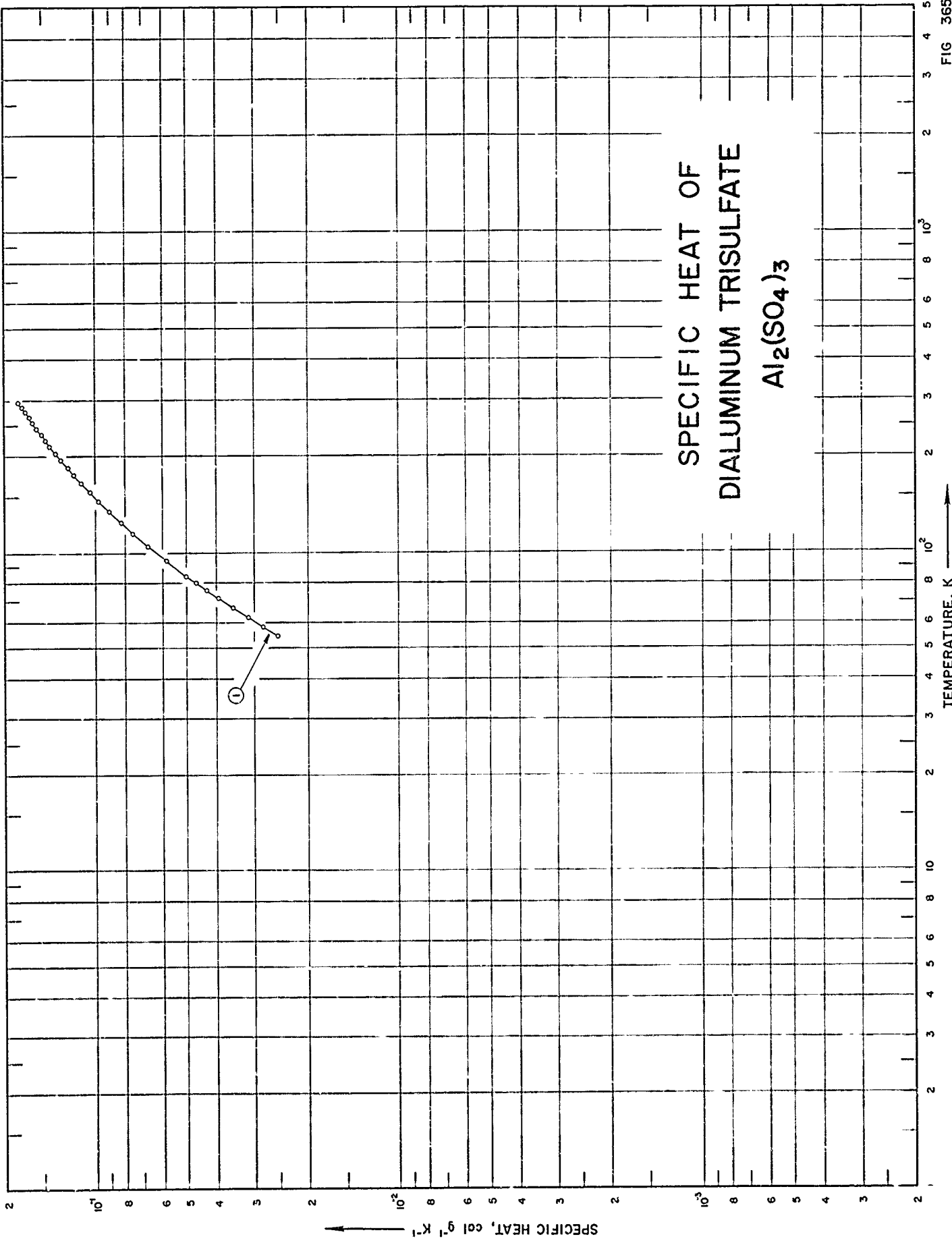

PRECEDING PAGE BLANK-NOT FILMED

SPECIFICATION TABLE NO. 365 SPECIFIC HEAT OF DIALUMINUM TRISULFATE, $Al_2(SO_4)_3$

[For Data Reported in Figure and Table No. 365]

Curve No.	Ref. No.	Year	Temp. Range, K	Reported Error, %	Name and Specimen Designation	Composition (weight percent), Specifications and Remarks
1	359	1946	55-296			99.41 $Al_2(SO_4)_3$, 0.32 H_2O , and 0.26 Al_2O_3 ; corrected for impurities.

DATA TABLE NO. 365 DIALUMINUM TRISULFATE, $Al_2(SO_4)_3$
 [Temperature, T, K; Specific Heat, C_p , Cal $g^{-1}K^{-1}$]

T	C_p
CURVE 1	
54.7	2.534×10^{-2}
58.4	2.839
62.4	3.174
65.9	3.566
71.7	3.984
75.9	4.355
80.2	4.721
84.3	5.095
94.4	5.934
104.4	6.752
114.9	7.582
123.9	8.269
134.8	9.099
145.5	9.856
155.2	1.052×10^{-1}
165.6	1.123
175.6	1.189
185.4	1.248
196.0	1.310
205.8	1.367
216.7	1.428
226.0	1.474
235.5	1.521
246.5	1.575
256.0	1.625
265.9	1.670
276.4	1.712
286.0	1.761
296.2	1.804

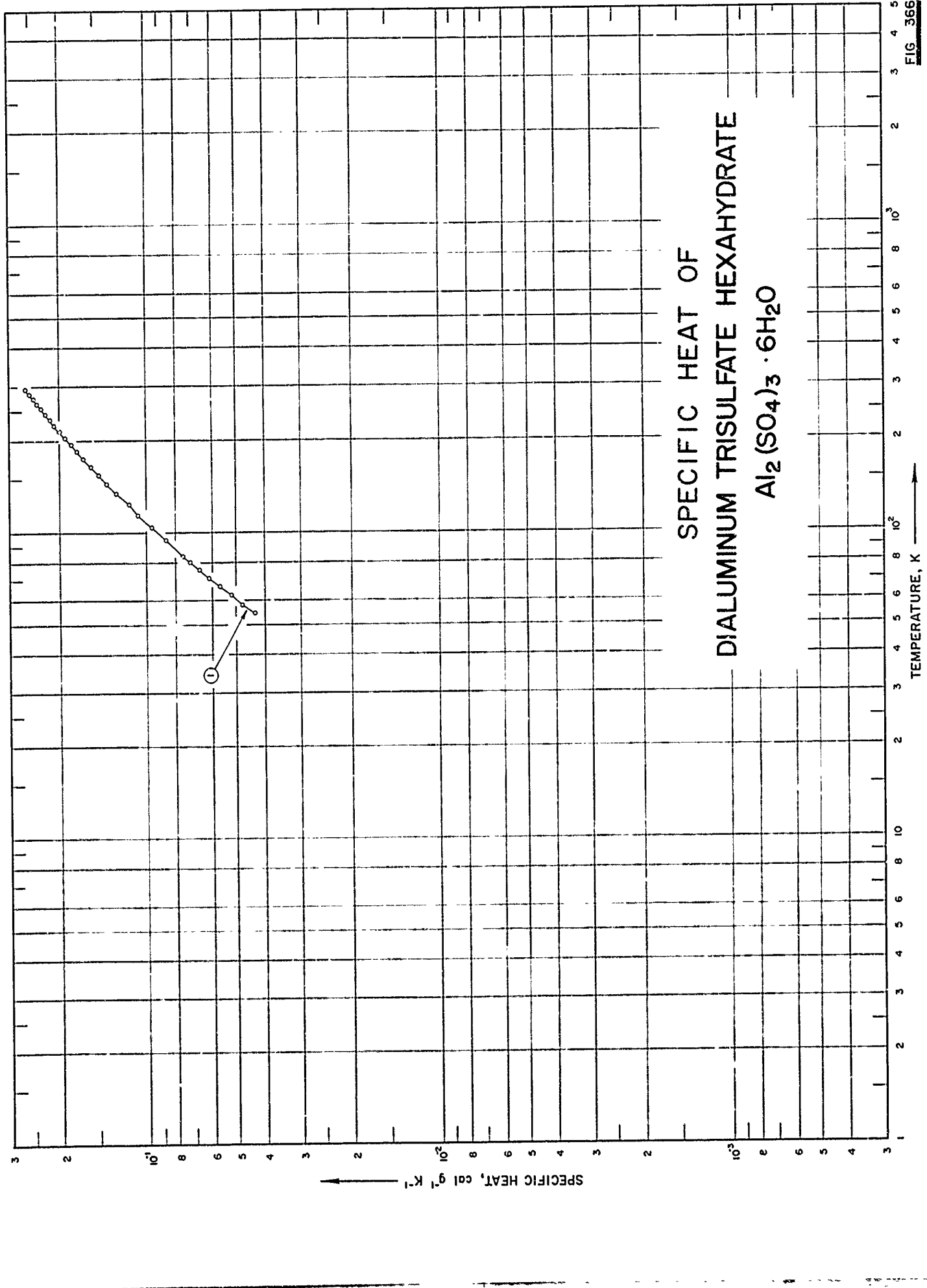

FIG. 366

SPECIFICATION TABLE NO. 366 SPECIFIC HEAT OF DIALUMINUM TRISULFATE HEXAHYDRATE, $Al_2(SO_4)_3 \cdot 6H_2O$

[For Data Reported in Figure and Table No. 366]

Curve No.	Ref. No.	Year	Temp. Range, K	Reported Error, %	Name and Specimen Designation	Composition (weight percent), Specifications and Remarks
1	359	1946	55-296			22.57 Al_2O_3 (22.64 theo); reagent grade aluminum sulfate octahydrate heated in air for 18 hrs at 140 C; pulverized; aged for 28 hrs at 80 C.

DATA TABLE NO. 366 SPECIFIC HEAT OF DIALUMINUM TRISULFATE HEXAHYDRATE, $\text{Al}_2(\text{SO}_4)_3 \cdot 6\text{H}_2\text{O}$
 [Temperature, T, K; Specific Heat, C_p , Cal $\text{g}^{-1} \text{K}^{-1}$]

T	C_p
CURVE 1	
54.5	4.325×10^{-2}
58.4	4.755
62.6	5.217
66.9	5.697
71.2	6.177
75.7	6.670
80.4	7.174
84.3	7.572
94.7	8.682
104.3	9.673
114.9	1.076×10^{-1}
124.2	1.169
135.1	1.278
145.6	1.379
155.6	1.474
165.4	1.565
175.6	1.658
185.6	1.745
195.9	1.835
206.0	1.920
216.6	2.006
226.3	2.082
235.7	2.155
245.9	2.234
256.2	2.317
265.9	2.390
276.0	2.461
286.1	2.532
296.1	2.610

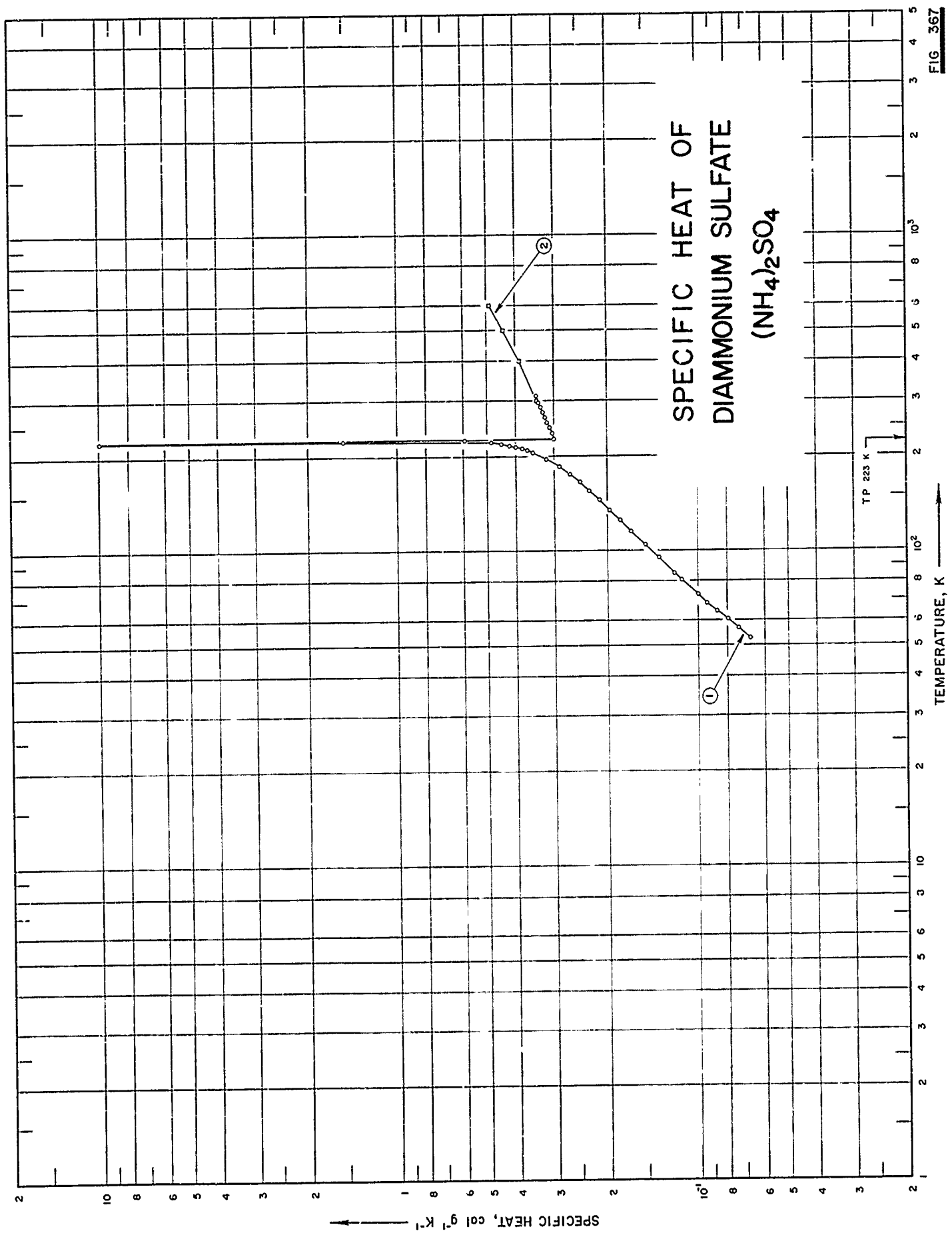

FIG 367

SPECIFICATION TABLE NO. 367 SPECIFIC HEAT OF DIAMMONIUM SULFATE, $(\text{NH}_4)_2\text{SO}_4$

[For Data Reported in Figure and Table No. 367]

Curve No.	Ref. No.	Year	Temp. Range, K	Reported Error, %	Name and Specimen Designation	Composition (weight percent), Specifications and Remarks
1	359	1946	53-311			99.96 $(\text{NH}_4)_2\text{SO}_4$; reagent grade; dried at 75 C.
2	359	1946	298-600			

DATA TABLE NO. 367 SPECIFIC HEAT OF DIAMMONIUM SULFATE, $(\text{NH}_4)_2\text{SO}_4$
 [Temperature, T, K; Specific Heat, C_p , Cal $\text{g}^{-1}\text{K}^{-1}$]

T	C_p	
	CURVE 1	CURVE 2
52.8	6.735×10^{-2}	3.391×10^{-4} *
56.6	7.355	3.400
60.4	7.999	3.909
64.3	8.665	4.417
68.1	9.354	4.926
72.5	1.005×10^{-1}	
80.6	1.136	
84.8	1.202	
94.8	1.356	
104.4	1.504	
115.4	1.674	
125.1	1.821	
134.8	1.974	
145.4	2.136	
155.5	2.302	
165.3	2.474	
175.5	2.677	
185.3	2.890	
196.0	3.133	
205.4	3.540	
208.6	3.698	
211.5	3.825	
214.3	4.024	
216.8	4.230	
219.3	4.487	
221.5	4.869	
223.0	1.523×10^0	
223.4	1.002×10	
224.7	5.960×10^{-1}	
227.1	3.001	
230.2	3.010*	
233.3	3.020*	
237.0	3.041	
246.7	3.103	
256.7	3.177	
266.0	3.215	
276.4	3.273	
286.0	3.327	
296.1	3.390	
305.7	3.432*	
310.6	3.449	

* Not shown on plot

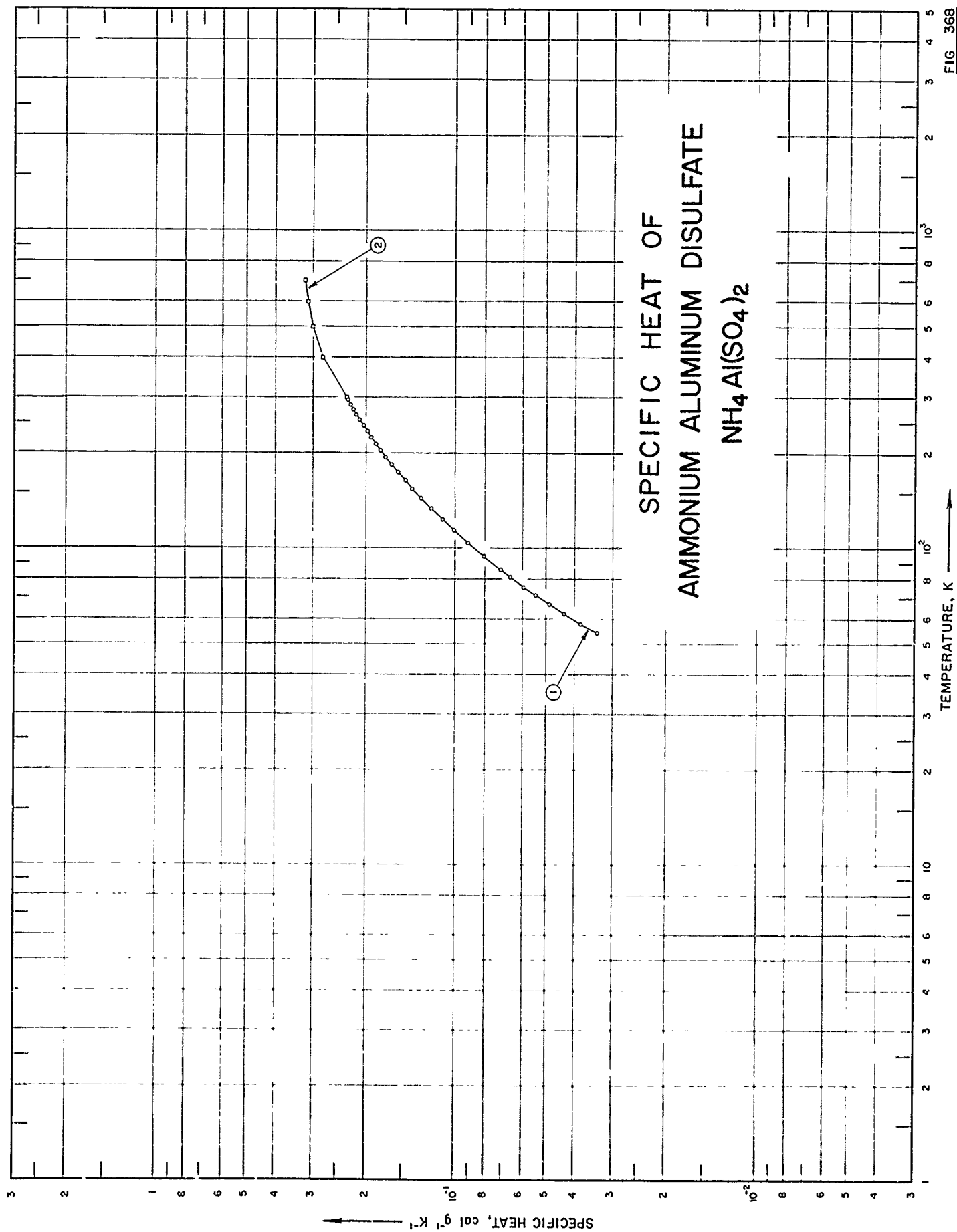

SPECIFICATION TABLE NO. 368 SPECIFIC HEAT OF AMMONIUM ALUMINUM DISULFATE, $\text{NH}_4\text{Al}(\text{SO}_4)_2$

[For Data Reported in Figure and Table No. 368]

Curve No.	Ref. No.	Year	Temp. Range, K	Reported Error, %	Name and Specimen Designation	Composition (weight percent). Specifications and Remarks
1	359	1946	55-296			66.37 SO_3 , 21.20 Al_2O_3 , 10.55 $(\text{HN}_4)_2\text{O}$ and 0.39 Na_2SO_4 .
2	359	1946	298-700			

DATA TABLE NO. 368 SPECIFIC HEAT OF AMMONIUM ALUMINUM DISULFATE, $\text{NH}_4\text{Al}(\text{SO}_4)_2$
 [Temperature, T, K; Specific Heat, C_p , Cal $\text{g}^{-1}\text{K}^{-1}$]

T	C_p
<u>CURVE 1</u>	
54.5	3.367×10^{-2}
58.2	3.796
62.6	4.314
67.1	4.841
71.5	5.364
75.8	5.874
81.5	6.524
86.3	7.043
94.0	7.991
104.5	9.008
115.1	1.008×10^{-1}
124.4	1.099
134.9	1.198
145.8	1.297
155.6	1.384
165.6	1.464
175.8	1.550
185.6	1.623
196.0	1.700
206.0	1.770
215.6	1.836
226.4	1.902
236.0	1.957
246.2	2.014
256.0	2.076
266.3	2.131
276.3	2.178
286.0	2.224
296.2	2.273
<u>CURVE 2</u>	
298.15	2.282×10^{-1} *
300	2.296
400	2.763
500	2.979
600	3.097
700	3.168

* Not shown on plot

FIG 369

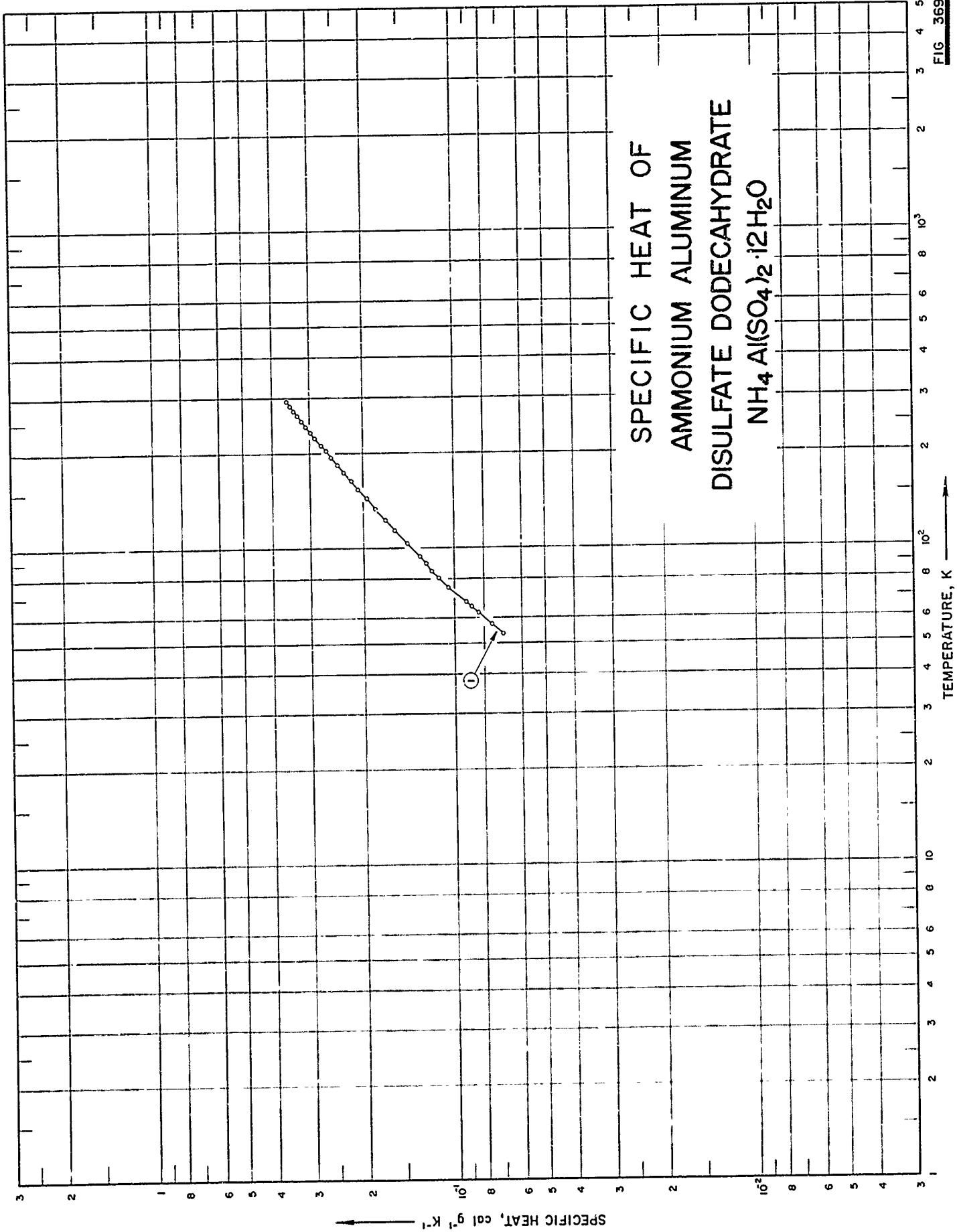

SPECIFICATION TABLE NO. 369 SPECIFIC HEAT OF AMMONIUM ALUMINUM DISULFATE DODECAHYDRATE, $\text{NH}_4\text{Al}(\text{SO}_4)_2 \cdot 12\text{H}_2\text{O}$

[For Data Reported in Figure and Table No. 369]

Curve No.	Ref. No.	Year	Temp. Range, K	Reported Error, %	Name and Specimen Designation	Composition (weight percent), Specifications and Remarks
1	359	1946	54-296			11.22 Al_2O_3 (11.24 theo) and 0.20 alkali salts; reagent grade.

DATA TABLE NO. 369 SPECIFIC HEAT OF AMMONIUM ALUMINUM DISULFATE DODECAHYDRATE, $\text{NH}_4\text{Al}(\text{SO}_4)_2 \cdot 12\text{H}_2\text{O}$

[Temperature, T, K; Specific Heat, C_p , Cal $\text{g}^{-1}\text{K}^{-1}$]

T	C_p
	CURVE 1
54.0	6.922×10^{-2}
54.9	7.063*
57.8	7.540
59.1	7.741*
63.1	8.383
65.8	8.811
68.1	9.179
75.5	1.050×10^{-1}
75.8	1.060*
81.0	1.126
85.9	1.191
90.1	1.248
94.6	1.309
104.3	1.437
115.2	1.577
124.2	1.692
134.9	1.829
145.3	1.953
155.6	2.078
165.5	2.198
175.7	2.321
185.5	2.431
196.4	2.554
205.8	2.658
210.1	2.711*
214.4	2.757
218.4	2.802*
222.4	2.841*
226.3	2.890
235.7	2.978
246.0	3.084
256.1	3.192
266.0	3.291
276.5	3.393
285.9	3.481
296.1	3.574

* Not shown on plot

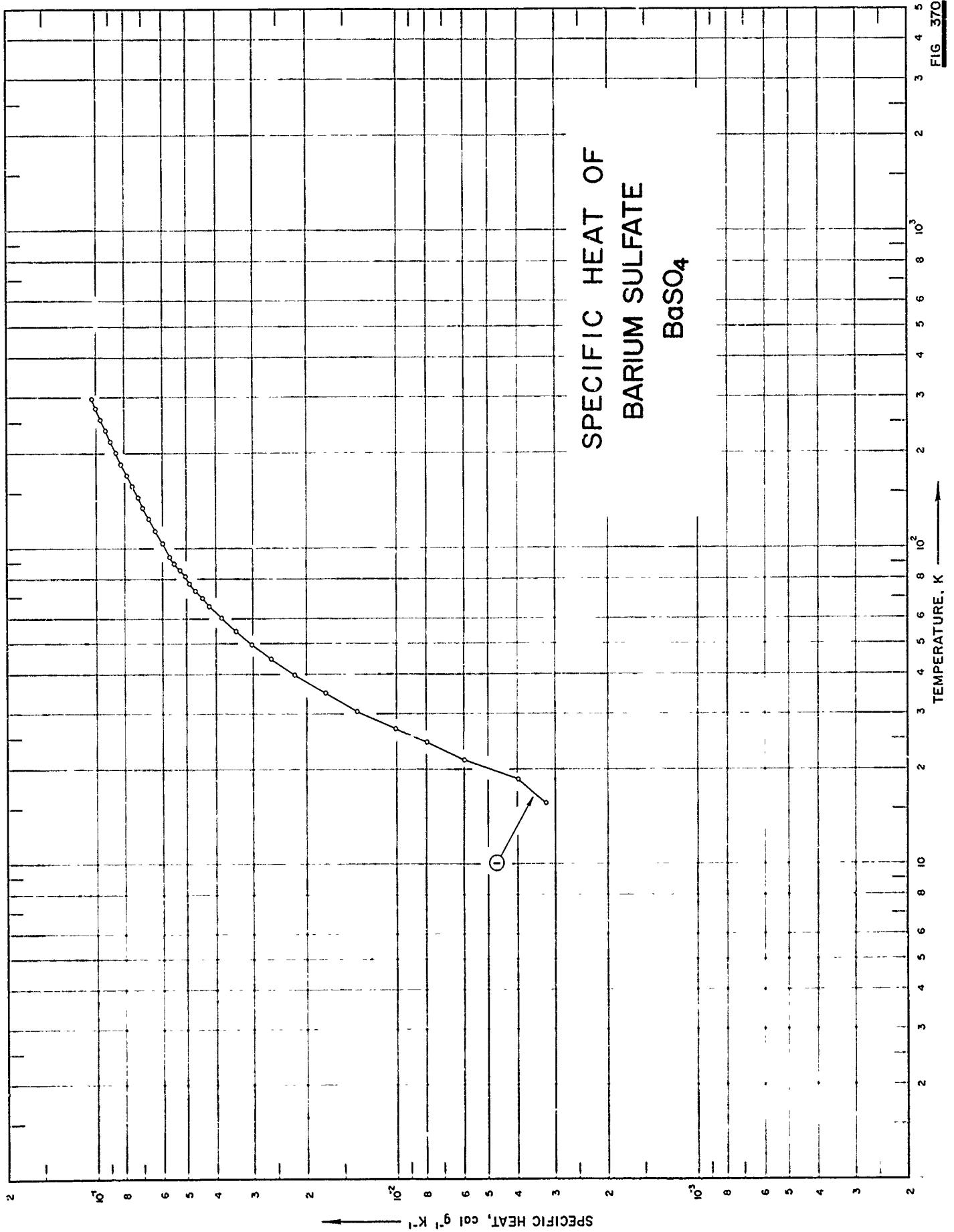

SPECIFICATION TABLE NO. 370 SPECIFIC HEAT OF BARIUM SULFATE, BaSO₄

{ For Data Reported in Figure and Table No. 370 }

Curve No.	Ref. No.	Year	Temp. Range, K	Reported Error, %	Name and Specimen Designation	Composition (weight percent), Specifications and Remarks
1	437	1933	16-298			C. P. quality; twice recrystallized.

DATA TABLE NO. 370 SPECIFIC HEAT OF BARIUM SULFATE, BaSO₄[Temperature, T, K; Specific Heat, C_p, Cal g⁻¹K⁻¹]

T	C _p	T	C _p
CURVE 1		CURVE 1 (cont.)	
15.72	3.213 x 10 ⁻³	277.68	1.016 x 10 ⁻¹
18.62	3.985	288.69	1.041*
21.49	5.998	298.23	1.034
24.42	7.969		
26.83	1.011 x 10 ⁻²		
30.56	1.367		
34.94	1.731		
39.83	2.198		
44.75	2.626		
49.69	3.042		
54.95	3.445		
60.49	3.852		
65.96	4.246		
69.61	4.452		
73.63	4.687		
77.79	4.914		
81.73	5.073		
85.52	5.287		
89.65	5.505		
94.22	5.703		
104.17	6.045		
109.29	6.221*		
114.25	6.392		
119.44	6.542		
124.84	6.718		
130.19	6.868*		
135.48	7.014		
140.83	7.159*		
146.18	7.284		
151.76	7.459*		
158.06	7.613		
171.16	7.930		
178.13	8.093*		
185.78	8.295		
193.94	8.487*		
201.87	8.620		
210.18	8.847*		
218.44	8.989		
228.03	9.241*		
237.28	9.549		
246.86	9.391		
256.21	9.683		
267.62	1.006 x 10 ⁻² *		

* Not shown on plot

FIG. 371

SPECIFIC HEAT OF
BERYLLIUM SULFATE
BeSO₄

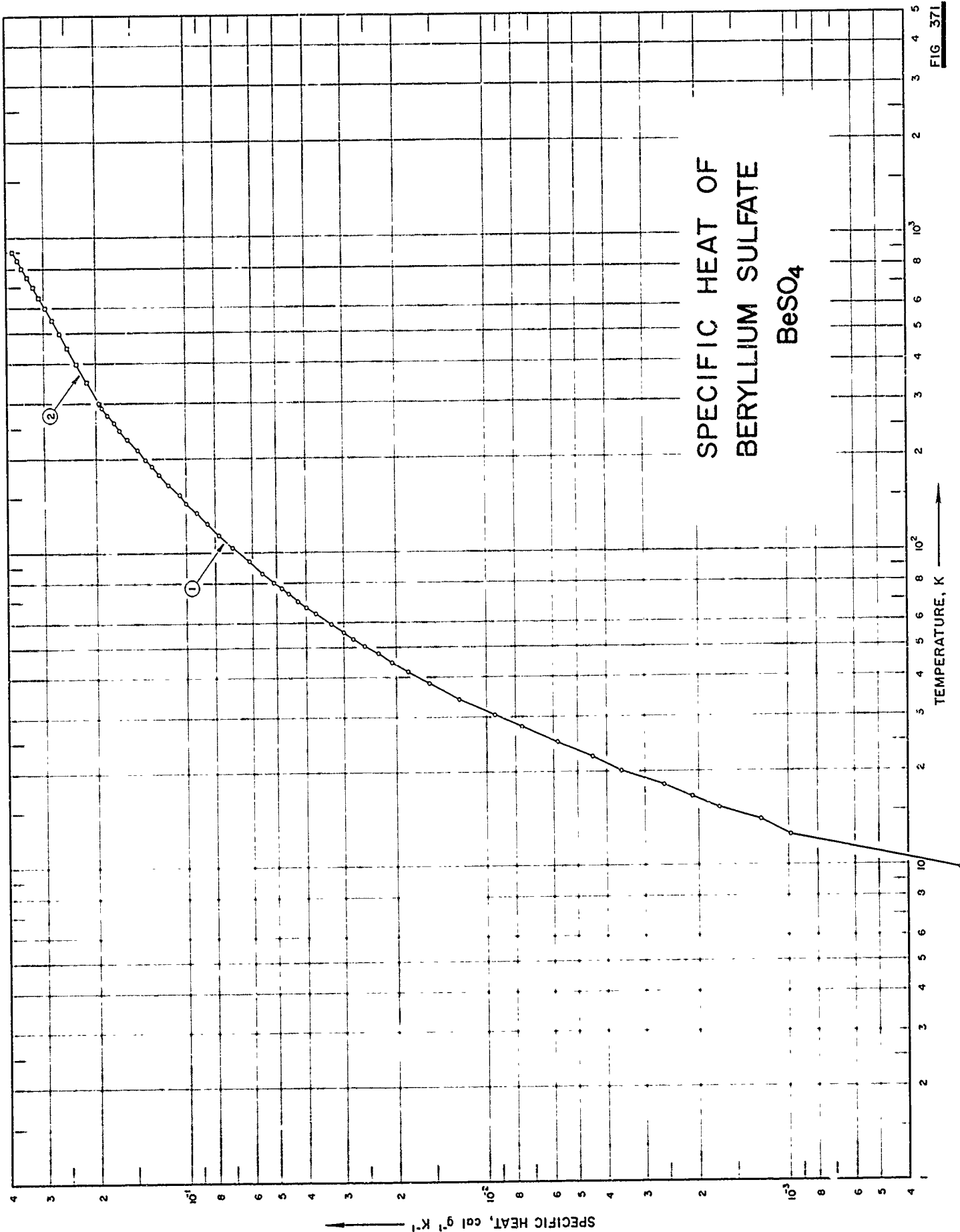

SPECIFICATION TABLE NO. 371 SPECIFIC HEAT OF BERYLLIUM SULFATE, BeSO_4

[For Data Reported in Figure and Table No. 371]

Curve No.	Ref. No.	Year	Temp. Range, K	Reported Error, %	Name and Specimen Designation	Composition (weight percent). Specifications and Remarks
1	438	1963	10-301			> 99.889 BeSO_4 , 0.01-0.10 Mg, 0.001-0.01 Al, 0.001-0.01 Fe and 0.0001-0.001 Mn; ground to fine powder and heated overnight to 1000 F to insure complete dehydration.
2	438	1963	298-900			Same as above.

DATA TABLE NO. 371 SPECIFIC HEAT OF BERYLLIUM SULFATE, BeSO₄[Temperature, T, K; Specific Heat, C_p, Cal g⁻¹K⁻¹]

T	CURVE 1		T	CURVE 1 (cont.)		T	CURVE 2 (cont.)	
	C _p	C _p		C _p	C _p		C _p	C _p
1.71	2.67 x 10 ⁻⁴		134.38	9.254 x 10 ⁻²		500	2.642	
12.56	9.80		137.87	9.520*		550	2.791	
14.07	1.24 x 10 ³		141.28	9.769*		600	2.937	
15.39	1.69		144.70	1.002 x 10 ⁻¹		650	3.080	
16.73	2.09		148.35	1.027*		700	3.221	
18.14	2.58		153.23	1.061		750	3.361	
20.08	3.58		158.15	1.096*		800	3.500	
22.30	4.46		162.57	1.125*		850	3.639	
24.95	5.84		166.49	1.154		900	3.777	
27.88	7.65		170.35	1.182*				
30.31	9.42		174.13	1.208*				
34.00	1.235 x 10 ²		177.86	1.232				
38.40	1.565		184.17	1.275*				
41.88	1.838		189.15	1.309				
44.83	2.073		194.57	1.347*				
47.68	2.305		198.88	1.373				
50.46	2.556		202.43	1.396*				
53.18	2.787		205.94	1.420*				
55.85	3.010		212.83	1.464				
56.29	3.042*		219.70	1.507*				
59.42	3.315		225.79	1.543*				
60.58	3.426*		231.12	1.575				
64.08	3.729		236.52	1.606*				
67.31	4.001		241.29	1.635*				
70.62	4.279		247.94	1.673				
74.01	4.564		254.46	1.711*				
77.21	4.833		260.86	1.747				
80.48	5.115		266.57	1.779*				
83.84	5.397*		272.02	1.810*				
86.58	5.617		275.34	1.829				
90.47	5.925*		281.30	1.864*				
94.20	6.225		286.04	1.889*				
95.96	6.352*		290.89	1.913				
97.78	6.499*		296.68	1.941*				
99.98	6.667*		299.20	1.964*				
104.54	7.031		301.28	1.965				
107.68	7.264*							
111.33	7.535*							
114.87	7.800							
117.59	8.007*		298.15	1.949 x 10 ⁻¹				
120.96	8.270*		300	1.959*				
124.23	8.516		350	2.154				
127.43	8.750*		400	2.327				
130.72	9.002*		450	2.489				

* Not shown on plot

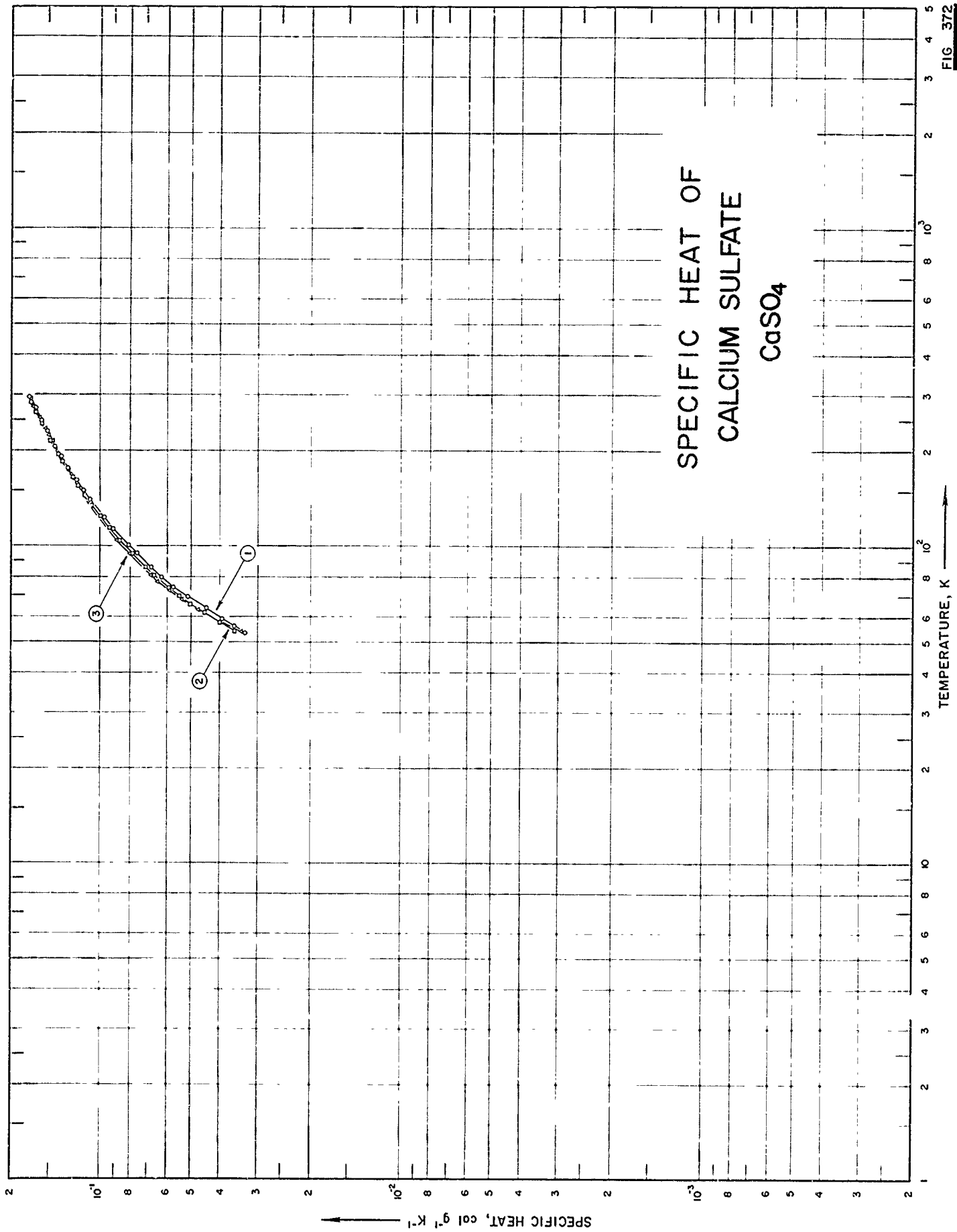

FIG. 372

SPECIFICATION TABLE NO. 372 SPECIFIC HEAT OF CALCIUM SULFATE, CaSO_4

[For Data Reported in Figure and Table No. 372]

Curve No.	Ref. No.	Year	Temp. Range, K	Reported Error, %	Name and Specimen Designation	Composition (weight percent), Specifications and Remarks
1	439	1941	54-296			0.09 $\text{CaSO}_4 \cdot 2\text{H}_2\text{O}$; natural anhydrite from Arden, Nevada.
2	439	1941	54-294		α - soluble anhydrite	0.02 H_2O .
3	439	1941	54-295		β - soluble anhydrite	0.25 H_2O .

DATA TABLE NO. 372 SPECIFIC HEAT OF CALCIUM SULFATE, CaSO₄[Temperature, T, K; Specific Heat, C_p, Cal g⁻¹K⁻¹]

T	C _p	T	C _p
<u>CURVE 1</u>			
53.5	3.313 x 10 ⁻³	195.5	1.385 x 10 ⁻¹
56.1	3.599	205.8	1.426*
59.3	3.967	215.6	1.476
63.9	4.459	232.6	1.538*
69.1	5.127	243.3	1.579
74.4	5.759	254.1	1.617*
79.6	6.324	265.5	1.651
85.0	6.817	275.8	1.681*
94.6	7.595	280.3	1.721
101.0	8.145	294.4	1.747*
113.8	9.138		
123.7	9.762	<u>CURVE 3</u>	
140.7	1.094 x 10 ⁻¹	54.1	3.416 x 10 ⁻²
149.8	1.149	58.5	3.989*
162.0	1.213	63.4	4.774
177.1	1.295	68.0	5.362
192.2	1.367	72.5	5.935
207.4	1.432	77.1	6.493
230.3	1.523	80.9	6.824
249.8	1.588	85.4	7.184*
272.8	1.665	94.6	8.028
275.7	1.694*	104.5	8.851
295.7	1.744	114.3	9.564*
		123.9	1.021 x 10 ⁻¹ *
		133.8	1.082
		143.7	1.134*
		154.1	1.195*
		163.8	1.241*
		174.3	1.289
		183.9	1.337*
		193.7	1.380*
		204.0	1.426
		214.1	1.465
		223.9	1.506
		235.0	1.545
		245.5	1.584*
		255.6	1.619
		266.0	1.653*
		275.7	1.684
		285.1	1.712*
		294.9	1.730
		<u>CURVE 2</u>	
54.1	3.585 x 10 ⁻²		
57.7	4.011		
61.8	4.510		
65.9	5.017		
69.8	5.480		
73.9	5.942		
81.0	6.670		
85.8	7.125		
94.5	7.882		
104.8	8.690		
117.7	9.424		
125.1	1.016 x 10 ⁻¹		
135.0	1.079		
145.5	1.139		
155.4	1.191		
165.2	1.242		
175.8	1.299		
185.6	1.344		

* Not shown on plot

FIG. 373

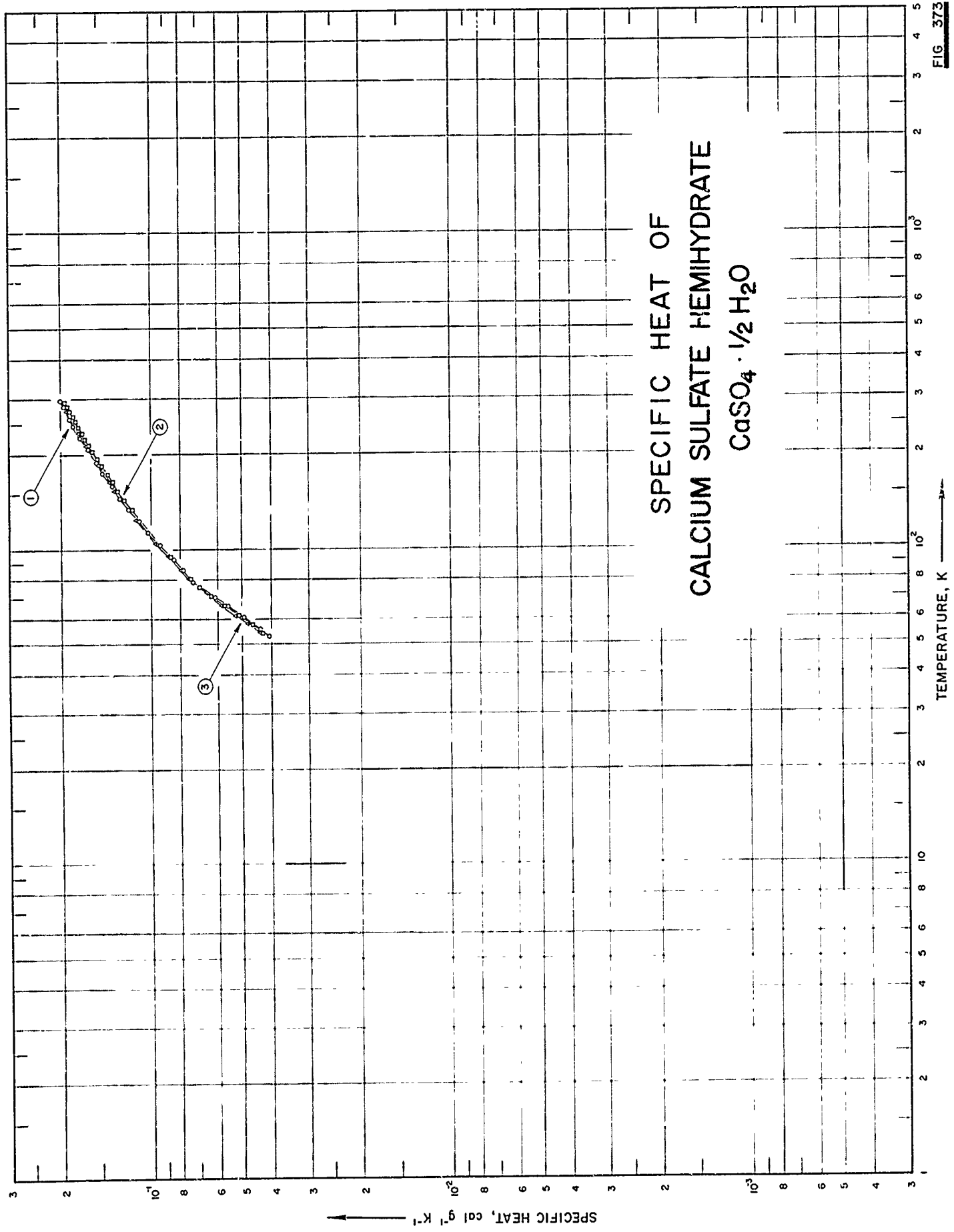

SPECIFICATION TABLE NO. 373 SPECIFIC HEAT OF CALCIUM SULFATE HEMIHYDRATE, $\text{CaSO}_4 \cdot \frac{1}{2}\text{H}_2\text{O}$

[For Data Reported in Figure and Table No. 373]

Curve No.	Ref. No.	Year	Temp. Range, K	Reported Error, %	Name and Specimen Designation	Composition (weight percent), Specifications and Remarks
1	439	1941	53-297		Hemihydrate	99.74 $\text{CaSO}_4 \cdot \frac{1}{2}\text{H}_2\text{O}$, 0.15 insoluble and 0.07 CaCO_3 , trace R_2O_3 ; 25% α and 75% β - hemihydrate; sample prepared from San Marcos, Mexico gypsum.
2	439	1941	54-295		α -hemihydrate	6.23 H_2O ; density = 2.757 g cm^{-3} .
3	439	1941	55-294		metastable β -hemihydrate	6.25 H_2O ; annealed 3 days; density = 2.637 g cm^{-3} .

DATA TABLE NO. 373 SPECIFIC HEAT OF CALCIUM SULFATE HEMIHYDRATE, $\text{CaSO}_4 \cdot \frac{1}{2}\text{H}_2\text{O}$
 [Temperature, T, K; Specific Heat, C_p , Cal $\text{g}^{-1}\text{K}^{-1}$]

T	C_p	T	C_p
	<u>CURVE 1</u>		<u>CURVE 2 (cont.)</u>
53.3	4.099×10^{-2}	194.5	1.527×10^{-1}
55.8	4.368	205.1	1.580
60.9	4.960	215.5	1.635
66.0	5.594	225.3	1.674
70.3	6.180	234.9	1.718
78.8	7.344	245.6	1.765
85.8	7.875	256.1	1.813
92.7	8.508	265.7	1.848
102.6	9.425	275.9	1.889
112.8	1.031×10^{-1}	285.4	1.920
122.7	1.102	294.6	1.957
134.9	1.199		
146.5	1.286		
155.8	1.368		
176.4	1.472		
188.0	1.535		
208.0	1.642		
226.7	1.743		
247.1	1.830		
260.1	1.890		
272.0	1.922*		
284.8	1.977		
297.0	2.025		
	<u>CURVE 2</u>		<u>CURVE 3</u>
54.4	4.189×10^{-2}	54.5	4.402×10^{-2}
57.9	4.630	58.0	4.843
61.9	5.126	61.9	5.346
66.4	5.739	66.4	5.904
71.0	6.366	70.8	6.449*
75.6	6.938	75.0	6.924*
80.9	7.461	81.3	7.578
85.7	7.854*	86.0	8.033
94.7	8.681	95.2	8.894
104.2	9.507*	105.0	9.762
114.0	1.031×10^{-1} *	114.7	1.055*
123.3	1.100*	124.6	1.131
133.6	1.175	135.0	1.209*
143.8	1.242	144.6	1.273*
153.7	1.308	154.8	1.339
164.0	1.366	164.6	1.396
173.9	1.417	175.0	1.456*
184.1	1.476	184.9	1.513
		194.7	1.564*
		204.9	1.619*
		214.8	1.665
		225.3	1.718*
		234.9	1.764
		245.1	1.802*
		255.6	1.858*
		265.9	1.898*
		275.6	1.941
		285.1	1.985*
		294.3	2.025*

* Not shown on plot

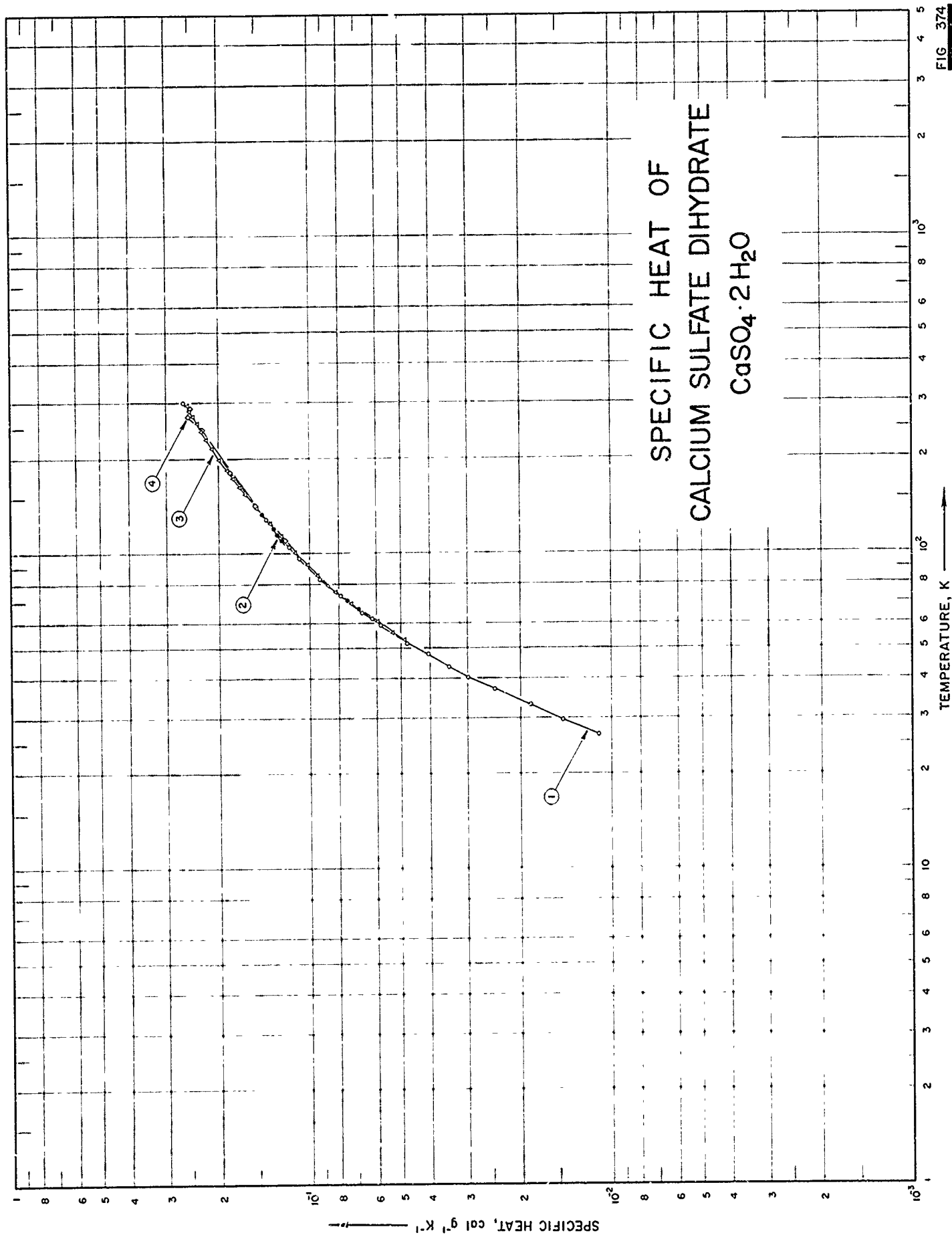

SPECIFICATION TABLE NO. 374 SPECIFIC HEAT OF CALCIUM SULFATE DIHYDRATE, $\text{CaSO}_4 \cdot 2\text{H}_2\text{O}$

[For Data Reported in Figure and Table No. 374]

Curve No.	Ref. No.	Year	Temp. Range, K	Reported Error, %	Name and Specimen Designation	Composition (weight percent), Specifications and Remarks
1	437	1933	19-302			20.85 H_2O (20.93 theo); Baker Adamson C.P. $\text{CaSO}_4 \cdot 2\text{H}_2\text{O}$, small crystals; dried and heated to 520 C.
2	437	1933	62-274			20.88 H_2O (20.93 theo); natural gypsum, large single crystal.
3	439	1941	53-295		selenite	0.20 CaCO_3 ; deposit from Ceerlash, Nevada.
4	439	1941	94-298		GYPSUM	0.37 anhydrite; from deposit near Arden, Nevada.

DATA TABLE NO. 374 SPECIFIC HEAT OF CALCIUM SULFATE DIHYDRATE, $\text{CaSO}_4 \cdot 2\text{H}_2\text{O}$ [Temperature, T, K; Specific Heat, C_p , Cal $\text{g}^{-1} \text{K}^{-1}$]

T	CURVE 1		T	CURVE 1 (cont.)		T	CURVE 3	
	C_p	10^3		C_p	10^3		C_p	10^2
18.70	3.950	10^3	231.90	2.226	10^3	53.0	4.856	10^2
26.71	1.104	10^2	238.23	2.253*		56.4	5.344	
29.64	1.440		245.64	2.297*		60.8	5.953	
33.18	1.859		254.02	2.344*		69.3	7.283	
37.11	2.445		263.29	2.382*		77.5	8.213	
40.36	2.991		272.18	2.457*		79.1	8.718	
43.77	3.479		282.11	2.476*		84.9	9.415	
47.84	4.054		292.67	2.572*		92.3	1.018	10^1
51.98	4.757		302.10	2.624		113.1	1.122	
56.56	5.419*					113.1	1.246	
59.47	5.826					125.2	1.363	
62.00	6.232					139.5	1.508	
65.34	6.703					153.6	1.633	
69.29	7.324*					162.2	1.706	
73.72	7.911					173.1	1.799	
78.41	8.544*					184.2	1.882	
83.24	9.171					198.7	1.922	
88.04	9.775*					215.9	2.106	
92.37	1.034	10^1 *				229.9	2.206	
96.90	1.079					243.0	2.280	
101.26	1.131*					258.7	2.367	
105.59	1.170					271.0	2.439	
109.84	1.211*					283.4	2.500	
114.04	1.250*					295.1	2.545	
118.22	1.292*							
123.62	1.333*							
128.39	1.399							
134.97	1.460*							
140.21	1.499*							
145.36	1.550*							
150.72	1.598*							
155.86	1.650*							
160.80	1.680*							
165.73	1.720*							
170.86	1.763*							
179.79	1.840*							
185.78	1.878*							
191.39	1.931*							
197.51	1.971*							
203.45	2.011*							
210.22	2.071*							
217.27	2.110*							
224.91	2.161*							

T	CURVE 2		T	CURVE 4	
	C_p	10^2 *		C_p	10^1 *
62.40	6.267	10^2 *	93.6	1.022	10^1 *
66.74	6.883		110.7	1.210	
70.84	7.498		142.2	1.519	
75.20	8.085*		181.0	1.843	
80.05	8.707*		217.0	2.094*	
84.70	9.305*		246.0	2.277	
101.38	1.128	10^1 *	272.1	2.543	
105.96	1.181*		289.4	2.496	
110.77	1.230		297.5	2.540*	
115.89	1.275				
120.88	1.321				
127.59	1.392				
133.12	1.443				
138.32	1.493*				
143.42	1.538*				
148.83	1.589*				
153.84	1.635*				
158.93	1.675*				
162.93	1.713*				
168.21	1.760*				
173.77	1.817*				
179.48	1.852*				
185.26	1.900*				
190.98	1.933*				
196.78	1.978*				
203.57	2.023*				
216.12	2.111*				
231.29	2.203*				
239.57	2.229*				
247.81	2.287*				
256.44	2.337*				
265.23	2.401*				
274.13	2.454*				

* Not shown on plot

FIG. 375

SPECIFIC HEAT OF
CESIUM ALUMINUM DISULFATE
DODECAHYDRATE $CsAl(SO_4)_3 \cdot 12H_2O$

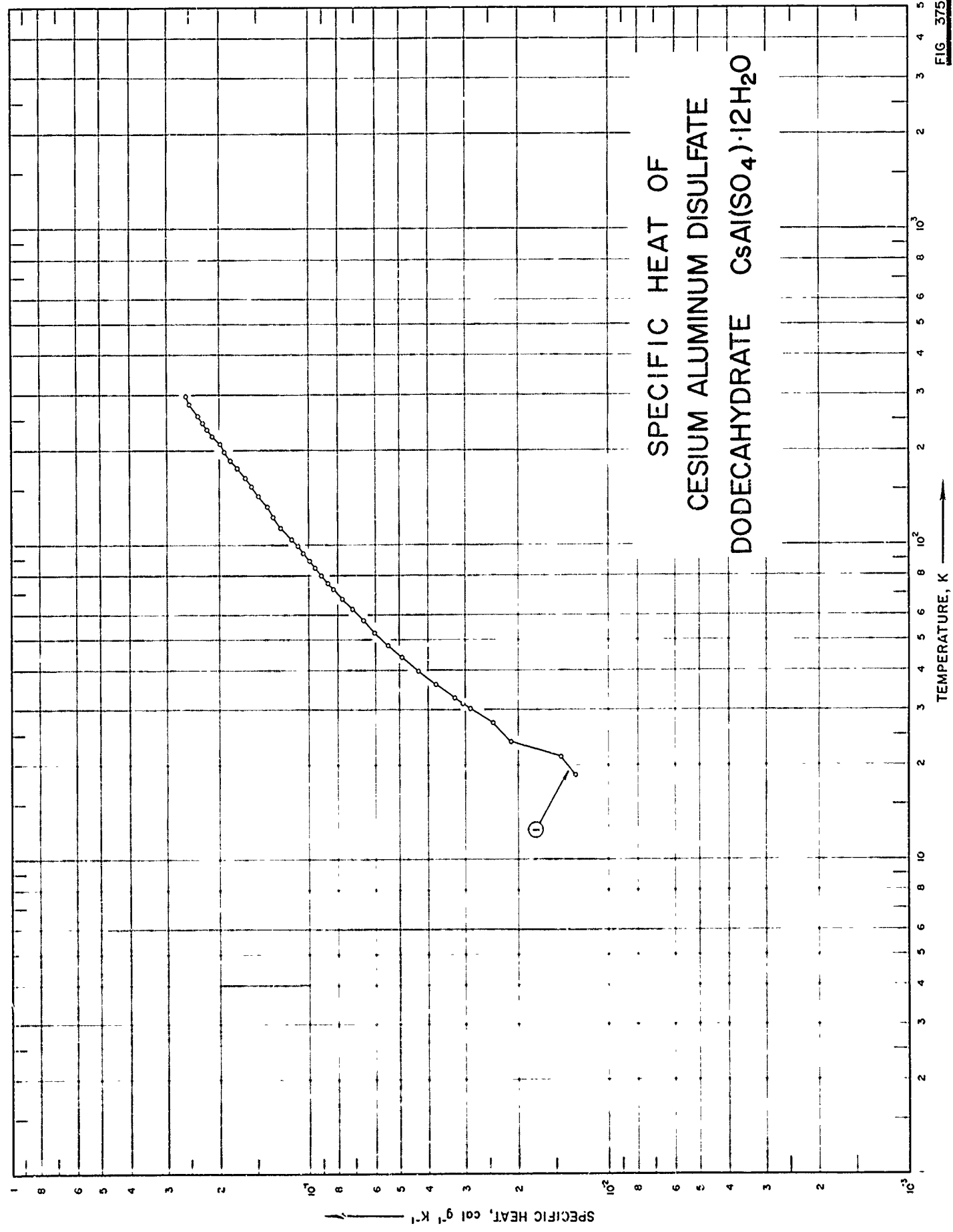

SPECIFICATION TABLE NO. 375 SPECIFIC HEAT OF CESIUM ALUMINUM DISULFATE DODECAHYDRATE, $\text{CsAl}(\text{SO}_4)_2 \cdot 12\text{H}_2\text{O}$

[For Data Reported in Figure and Table No. 375]

Curve No.	Ref. No.	Year	Temp. Range, K	Reported Error, %	Name and Specimen Designation	Composition (weight percent), Specifications and Remarks
1	440	1928	19-29°	0.25 average deviation	Cesium alum	37.98 H ₂ O (88.05 theo); density (20C) = 1.978 g cm ⁻³ .

DATA TABLE NO. 375 SPECIFIC HEAT OF CESIUM ALUMINUM DISULFATE DODECAHYDRATE, $\text{CsAl}(\text{SO}_4)_2 \cdot 12\text{H}_2\text{O}$ [Temperature, T, K; Specific Heat, C_p , Cal $\text{g}^{-1} \text{K}^{-1}$]

T	C_p		T	C_p	
	CURVE 1	$10^3 \times 10^3$			CURVE 1 (cont.)
18.71	1.29	10^3	227.88	2.122	10^3
21.26	1.46		233.78	2.208	
23.70	2.14		239.29	2.247*	
27.23	2.44		245.25	2.275	
30.25	2.50		251.62	2.321*	
31.31	3.08		257.77	2.356	
32.65	3.29		263.77	2.409*	
36.13	3.79		281.30	2.521	
39.77	4.34		286.73	2.544*	
44.17	4.94		292.42	2.578*	
48.60	5.46		297.84	2.586	
52.87	6.06				
57.71	6.63				
62.68	7.20				
67.57	7.80				
72.63	8.33				
75.88	8.67				
80.07	9.12				
84.84	9.56				
90.26	9.96				
94.20	1.051×10^4				
99.62	1.098				
104.61	1.150				
109.24	1.189*				
113.61	1.254				
117.80	1.270*				
122.52	1.322				
127.68	1.363*				
132.57	1.379				
137.90	1.428*				
143.63	1.488				
149.03	1.518*				
154.17	1.569				
159.43	1.603*				
164.62	1.642				
169.46	1.684*				
176.26	1.745				
181.56	1.796*				
187.12	1.840				
192.82	1.882*				
198.19	1.925				
205.72	1.955*				
210.20	1.997				
215.83	2.091*				
221.86	2.124				

* Not shown on plot

SPECIFIC HEAT OF
COBALT SULFATE HEPTAHYDRATE
 $\text{CoSO}_4 \cdot 7\text{H}_2\text{O}$

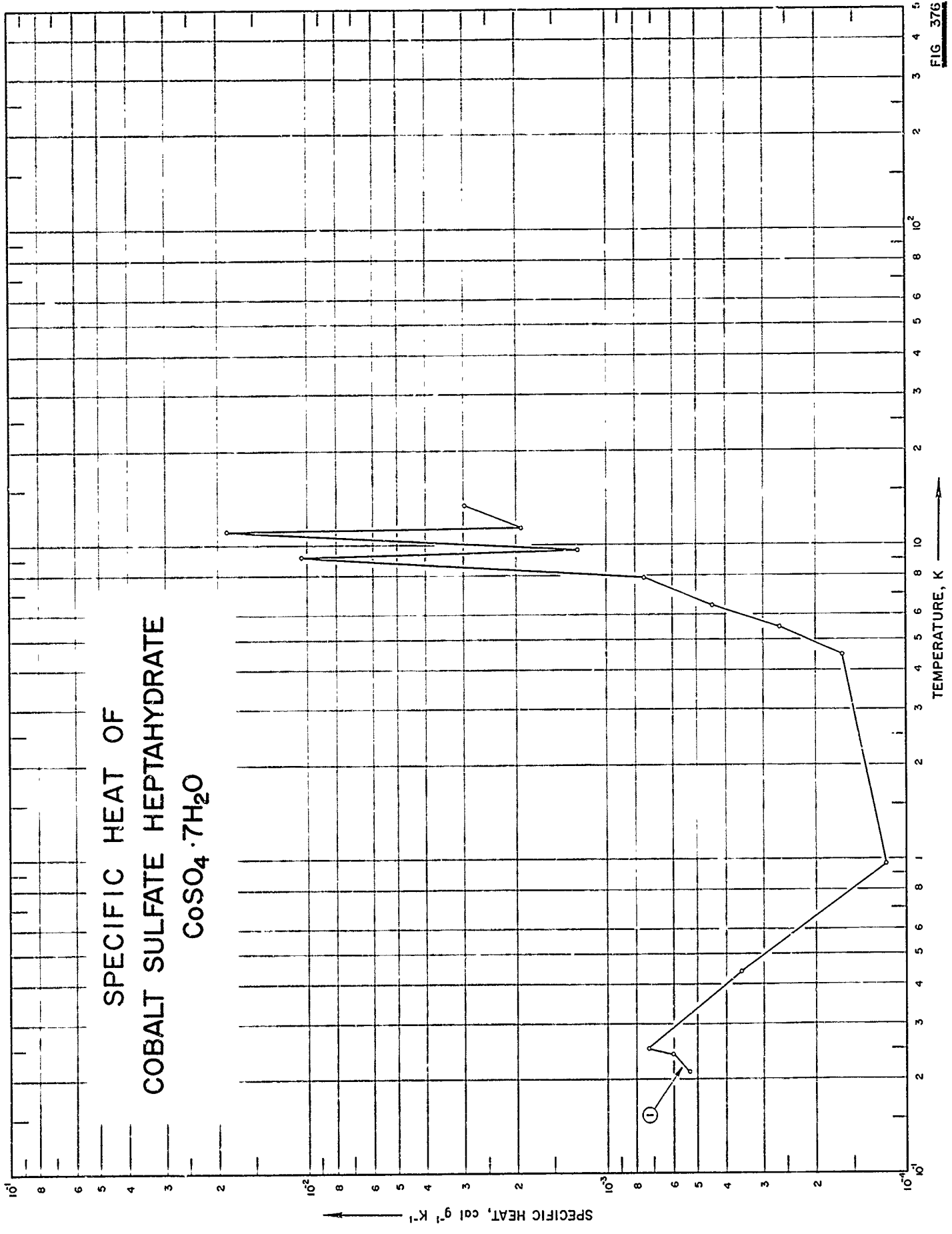

FIG. 376

SPECIFICATION TABLE NO. 376 SPECIFIC HEAT OF COBALT SULFATE HEPTAHYDRATE, $\text{CoSO}_4 \cdot 7\text{H}_2\text{O}$

[For Data Reported in Figure and Table No. 376]

Curve No.	Ref. No.	Year	Temp. Range, K	Reported Error, %	Name and Specimen Designation	Composition (weight percent), Specifications and Remarks
1	441	1949	0.2-13			44.76 F ₂ O (44.86 theo); powdered crystalline.

DATA TABLE NO. 376 SPECIFIC HEAT OF COBALT SULFATE HEPTAHYDRATE, $\text{CoSO}_4 \cdot 7\text{H}_2\text{O}$
 [Temperature, T, K; Specific Heat, C_p , Cal $\text{g}^{-1} \text{K}^{-1}$]

T	C_p
CURVE 1	
Series I	
0.25	7.293×10^{-4}
4.48	1.636
5.46	2.633
6.41	4.447
7.88	7.471
9.17	1.053×10^{-2}
11.19	1.875
Series II	
0.21	5.336×10^{-4}
0.24	6.048
0.44	3.558
0.96	1.174
Series III	
9.66	1.256×10^{-3}
11.37	1.925
13.33	2.974

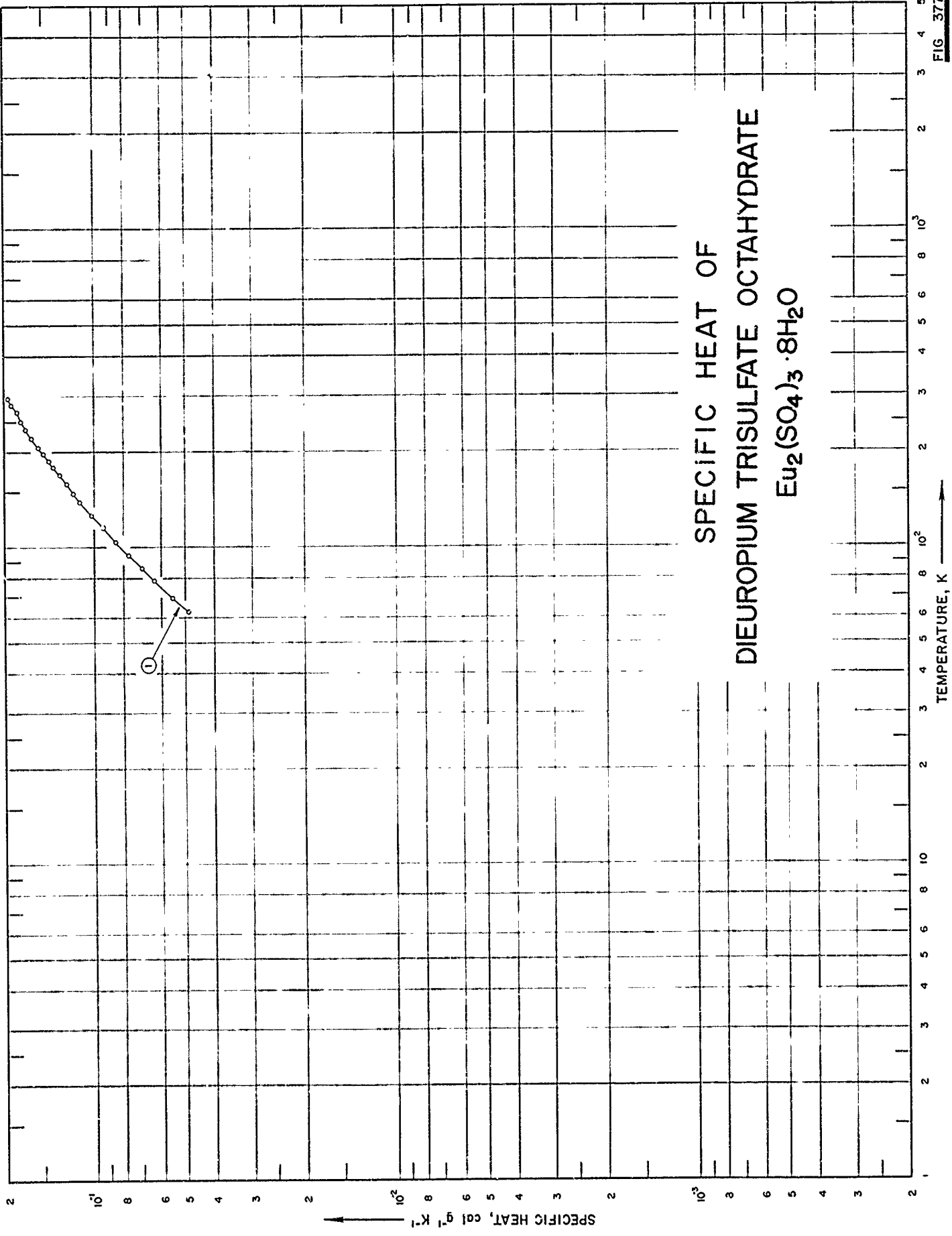

SPECIFIC HEAT, cal g⁻¹ K⁻¹

TEMPERATURE, K

SPECIFICATION TABLE NO. 377 SPECIFIC HEAT OF DIUROPIUM TRISULFATE OCTAHYDRATE, $\text{Eu}_2(\text{SO}_4)_3 \cdot 8\text{H}_2\text{O}$

[For Data Reported in Figure and Table No. 377]

Curve No.	Ref. No.	Year	Temp. Range, K	Reported Error, %	Name and Specimen Designation	Composition (weight percent), Specifications and Remarks
1	442	1942	63-295	0.3-0.5		0.01 Nd; fine crystalline powder.

DATA TABLE NO. 377 SPECIFIC HEAT OF DIIUROPIUM TRISULFATE OCTAHYDRATE, $\text{Eu}_2(\text{SO}_4)_3 \cdot 8\text{H}_2\text{O}$
 [Temperature, T, K; Specific Heat, C_p , Cal $\text{g}^{-1}\text{K}^{-1}$]

T	C_p	T	C_p
CURVE 1		CURVE 1 (cont.)	
62.83	4.949×10^{-2}	281.78	1.911×10^{-1}
65.67	5.227*	286.22	1.923*
69.49	5.564	290.74	1.960*
74.01	5.949*	295.23	1.967
78.55	6.372		
82.68	6.754*		
86.40	7.032		
94.51	7.760		
99.61	8.213*		
104.41	8.585		
110.29	9.105*		
116.11	9.476		
121.16	9.901*		
127.37	1.038×10^{-1}		
134.48	1.085*		
139.90	1.133		
144.27	1.168*		
148.82	1.191		
153.90	1.223*		
159.48	1.259		
164.87	1.301*		
169.93	1.322		
174.85	1.364*		
179.49	1.383		
183.90	1.404*		
188.27	1.429		
193.03	1.455*		
197.96	1.499		
202.71	1.524*		
207.51	1.551		
212.21	1.573*		
221.12	1.639		
225.35	1.657*		
226.91	1.661*		
231.65	1.680*		
236.70	1.719		
242.61	1.726*		
246.01	1.753*		
250.78	1.774		
255.83	1.808*		
264.29	1.827*		
268.46	1.825		
272.84	1.863*		
277.28	1.896*		

* Not shown on plot

SPECIFIC HEAT OF
IRON SULFATE HEPTAHYDRATE
 $\text{FeSO}_4 \cdot 7\text{H}_2\text{O}$

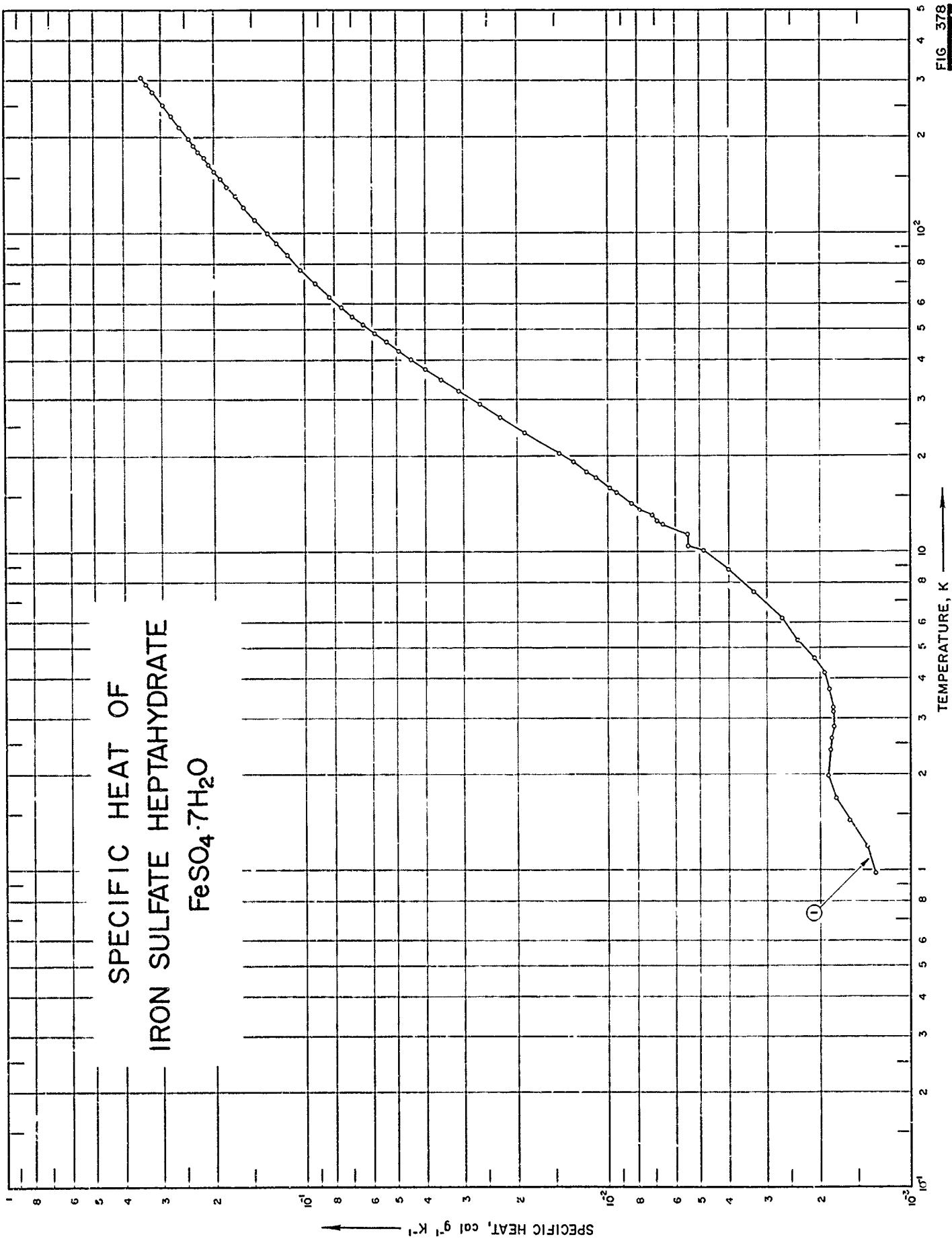

FIG. 378

SPECIFICATION TABLE NO. 378 SPECIFIC HEAT OF IRON SULFATE HEPTAHYDRATE, $\text{FeSO}_4 \cdot 7\text{H}_2\text{O}$

[For Data Reported in Figure and Table No. 378]

Curve No.	Ref. No.	Year	Temp. Range, K	Reported Error, %	Name and Specimen Designation	Composition (weight percent), Specifications and Remarks
1	443	1949	13-308			0.05 alkali and alkaline earth, 0.01 Mn, 0.005 Ni, 0.004 Co and 0.003 Cu; prepared by recrystallizing commercial low manganese and analytical reagent grade $\text{FeSO}_4 \cdot 7\text{H}_2\text{O}$.

DATA TABLE NO. 378 SPECIFIC HEAT OF IRON SULFATE HEPTAHYDRATE, $\text{FeSO}_4 \cdot 7\text{H}_2\text{O}$
 [Temperature, T, K; Specific Heat, C_p , Cal $\text{g}^{-1}\text{K}^{-1}$]

T	C_p	T	C_p
CURVE I		CURVE I (cont.)	
Series I			
92.94	1.247×10^{-1}	206.22	2.516×10^{-1} *
99.54	1.330	215.43	2.604
277.55	3.195	224.12	2.691*
284.11	3.255*	232.81	2.778
292.53	3.329	242.74	2.869*
		252.01	2.964
		260.80	3.039*
		269.80	3.129*
		279.79	3.233*
		289.99	3.331*
		299.37	3.404*
		307.67	3.476
			Series III
		140.13	1.808×10^{-1}
		147.64	1.896
T	C_p		
CURVE I			
Series II			
13.14	7.193×10^{-3}		
14.21	8.416		
15.82	9.891		
17.75	1.180×10^{-2}		
20.32	1.460		
23.64	1.895		
26.45	2.270		
29.16	2.651		
31.99	3.100		
34.72	3.568		
37.47	4.007		
40.02	4.453		
42.72	4.902		
45.64	5.388		
48.54	5.881		
51.71	6.431		
54.87	6.988		
58.50	7.568		
63.40	8.323		
69.59	9.265		
76.90	1.032×10^{-1}		
85.07	1.144		
93.53	1.244*		
102.18	1.367*		
110.98	1.472		
121.50	1.597		
131.67	1.716		
139.99	1.822		
147.92	1.919		
156.33	1.992		
164.30	2.079		
172.46	2.167		
180.67	2.263		
188.34	2.340		
197.97	2.425		

* Not shown on plot

SPECIFIC HEAT OF
DIMERCURY SULFATE
 Hg_2SO_4

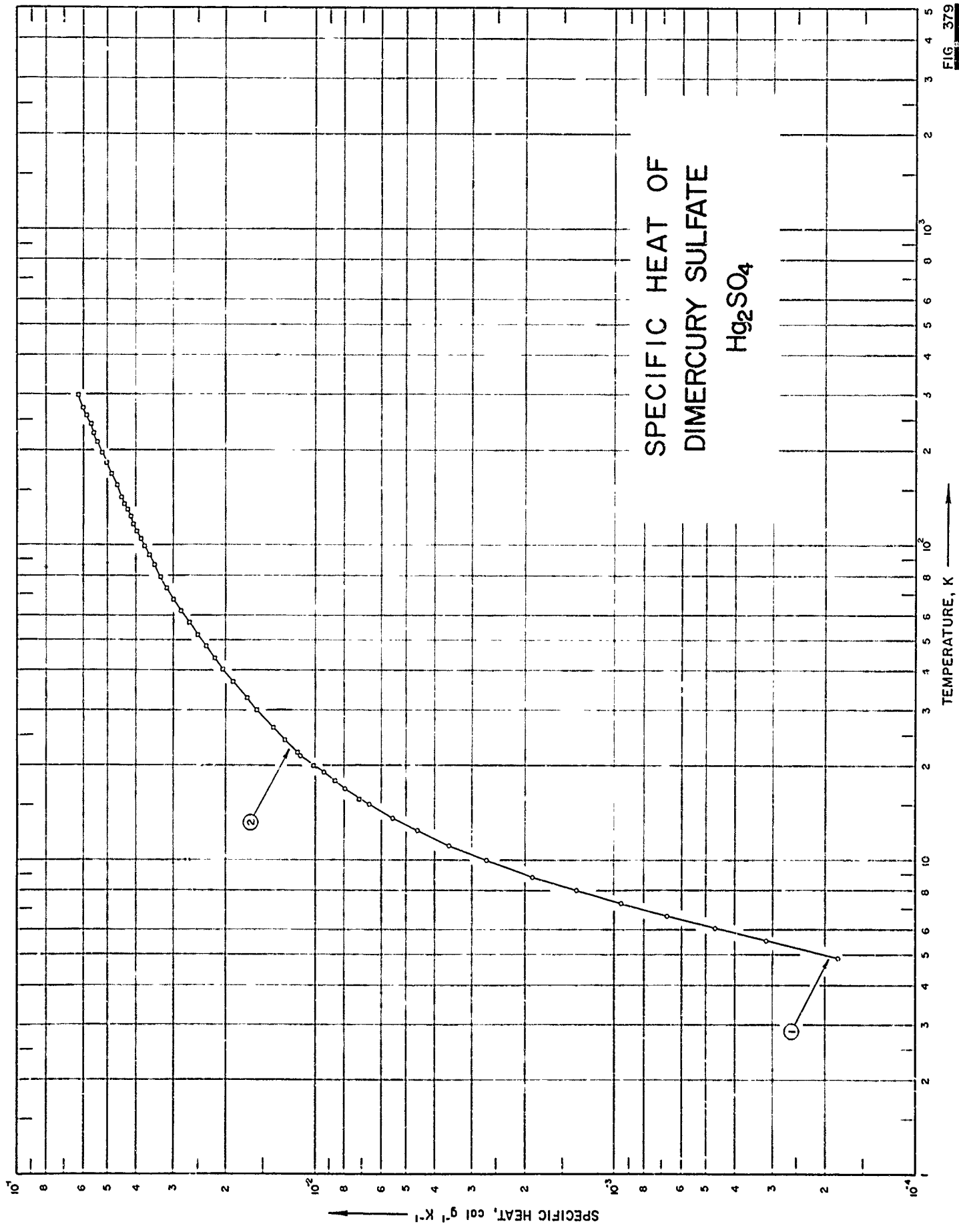

SPECIFICATION TABLE NO. 379 SPECIFIC HEAT OF DIMERCURY SULFATE, Hg_2SO_4

[For Data Reported in Figure and Table No. 379]

Curve No.	Ref. No.	Year	Temp. Range, K	Reported Error, %	Name and Specimen Designation	Composition (weight percent), Specifications and Remarks
1	444	1960	5-21			Ratio: $\text{SO}_4^{2-}/\text{Hg}_2\text{SO}_4 = 0.19316$ (0.19317 theo).
2	445	1962	16-299			Same as above.

DATA TABLE NO. 379 SPECIFIC HEAT OF DIMERCURY SULFATE, Hg_2SO_4
 [Temperature, T, K; Specific Heat, C_p , Cal $\text{g}^{-1}\text{K}^{-1}$]

T	C_p
CURVE I	
Series I	
11.156	3.592×10^{-3}
12.412	4.597
13.624	5.578
15.089	6.690
16.869	8.036
19.016	9.441
21.485	1.133×10^{-2}
Series II	
4.851	1.824×10^{-4}
5.523	3.163
6.063	4.673
6.637	6.759
7.291	9.586
8.016	1.362×10^{-3}
8.840	1.892
9.967	2.717

SPECIFIC HEAT OF
 NICKEL SULFATE HEXAHYDRATE
 $\text{NiSO}_4 \cdot 6\text{H}_2\text{O}$

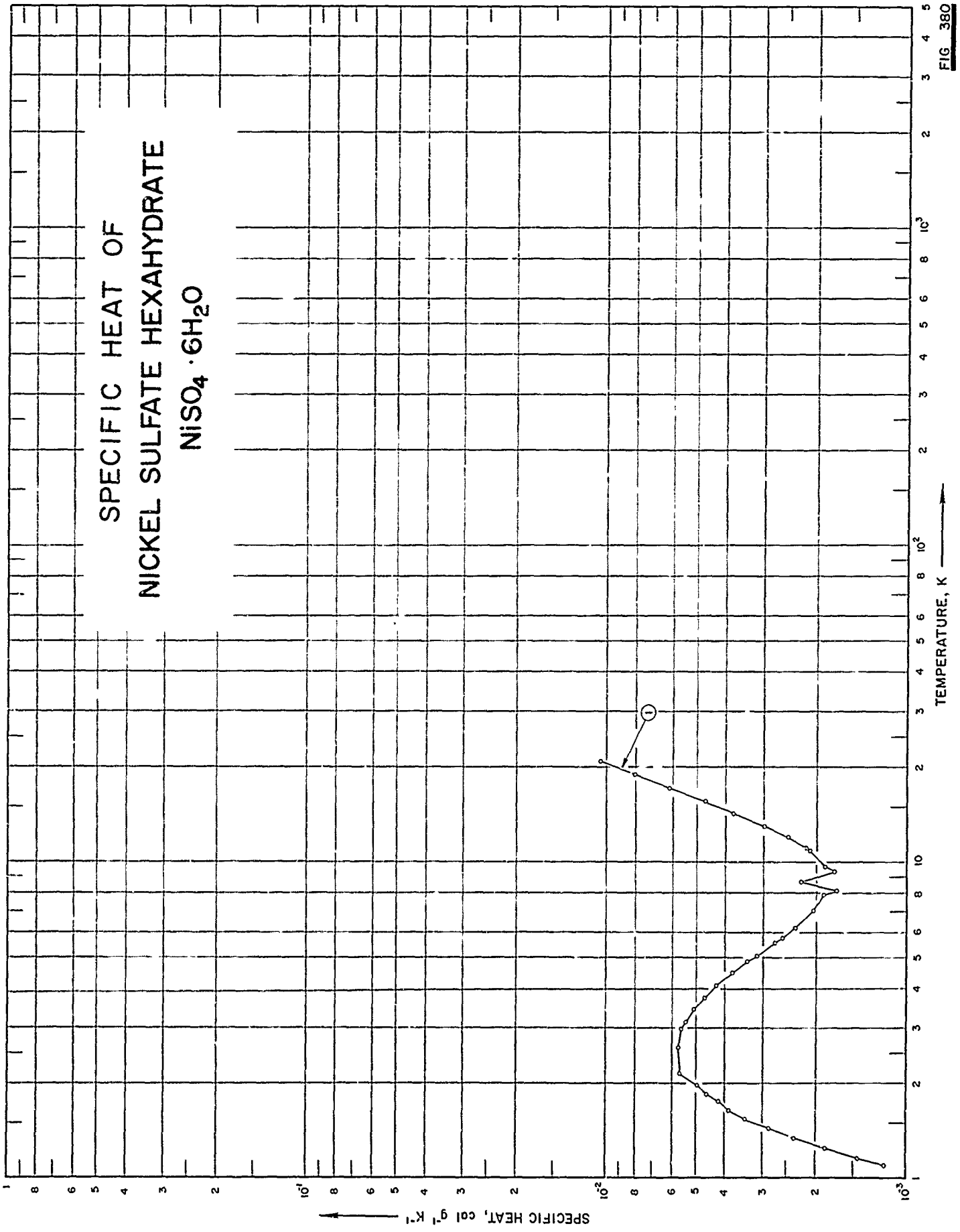

FIG 380

SPECIFICATION TABLE NO. 380 SPECIFIC HEAT OF NICKEL SULFATE HEXAHYDRATE, $\text{NiSO}_4 \cdot 6\text{H}_2\text{O}$

[For Data Reported in Figure and Table No. 380]

Curve No.	Ref. No.	Year	Temp. Range, K	Reported Error, %	Name and Specimen Designation	Composition (weight percent), Specifications and Remarks
1	446	1963	5-11			0.04 Mg, 0.02 Co, 0.003 Al, 0.003 Cu, 0.001 Fe and 0.001 Si; tetragonal symmetry.

DATA TABLE NO. 380 SPECIFIC HEAT OF NICKEL SULFATE HEXAHYDRATE, $\text{NiSO}_4 \cdot 6\text{H}_2\text{O}$ [Temperature, T, K; Specific Heat, C_p , Cal $\text{g}^{-1}\text{K}^{-1}$]

T	C_p	T	C_p
<u>CURVE I</u>			
Series I			
5.09	3.142×10^{-3}	1.542	3.432
5.60	2.735	1.643	3.873
6.25	2.340	Series V	
7.05	2.035	2.972	5.634×10^{-3}
7.90	1.898	5.780	2.576
8.68	2.267	6.910	2.039
9.70	1.868	8.120	1.720
11.12	2.172	9.360	1.742
Series II			
10.87	2.115×10^{-3}		
12.00	2.488		
13.01	2.958		
14.26	3.785		
15.60	4.721		
17.20	6.171		
18.95	8.073		
20.83	1.050×10^{-3}		
Series III			
1.756	4.234×10^{-3}		
1.851	4.619		
1.978	4.957		
2.150	5.402		
2.381	5.660		
2.630	5.710		
2.884	5.634		
3.148	5.391		
3.445	5.071		
3.747	4.676		
4.078	4.288		
4.461	3.793		
4.873	3.375		
Series IV			
1.103	1.176×10^{-3}		
1.161	1.446		
1.246	1.868		
1.341	2.359		
1.437	2.865		

SPECIFIC HEAT OF DIPOTASSIUM SULFATE K_2SO_4

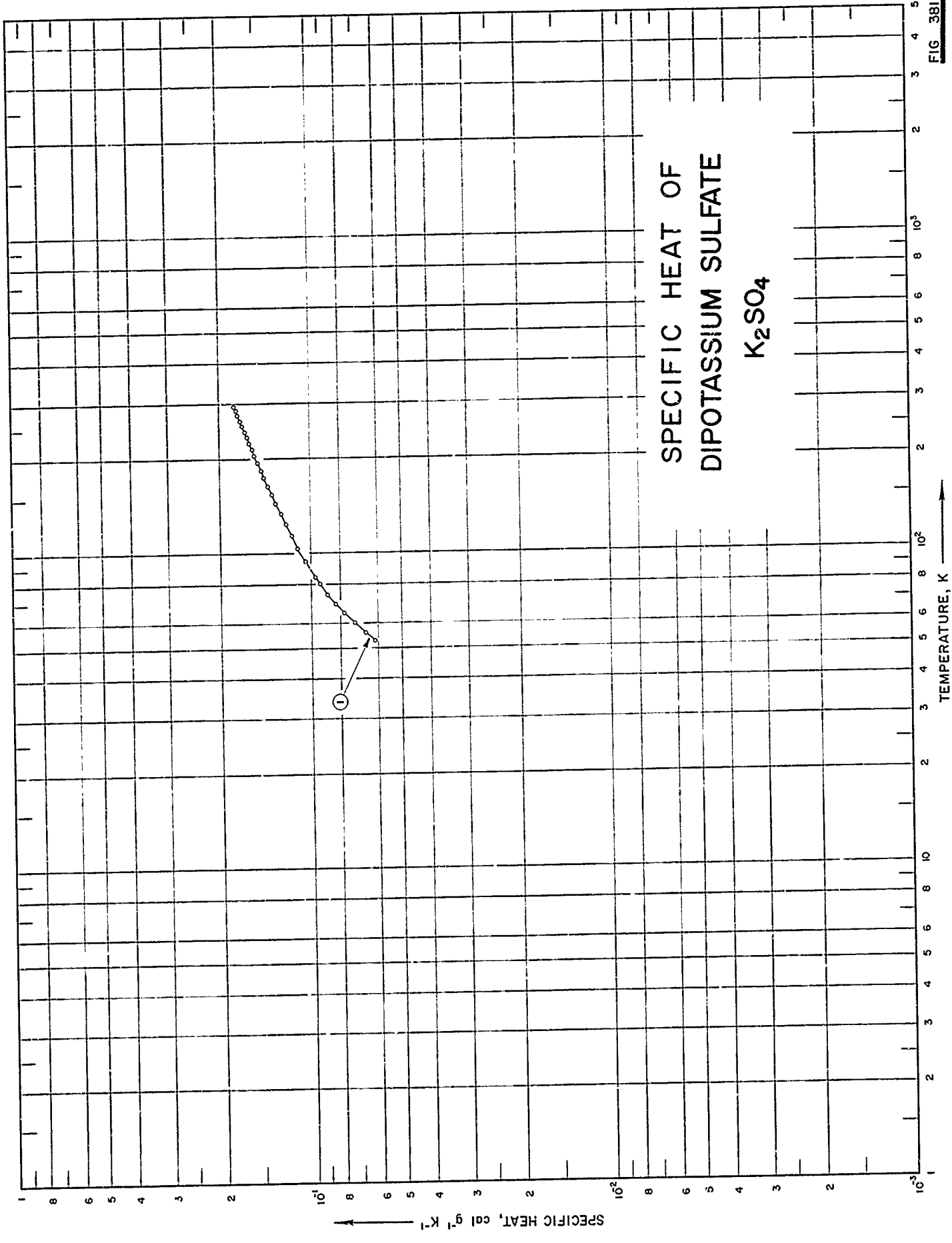

SPECIFICATION TABLE NO. 381 SPECIFIC HEAT OF DIPOTASSIUM SULFATE, K_2SO_4

[For Data Reported in Figure and Table No. 381]

Curve No.	Ref. No.	Year	Temp. Range, K	Reported Error, %	Name and Specimen Designation	Composition (weight percent), Specifications and Remarks
1	359	1946	53-296			99.7 K_2SO_4 ; reagent grade; dried several hours at 140 C.

DATA TABLE NO. 381 SPECIFIC HEAT OF DIPOTASSIUM SULFATE, K_2SO_4 [Temperature, T, K; Specific Heat, C_p , Cal $g^{-1} K^{-1}$]

T	C_p
	CURVE 1
52.7	6.158×10^{-2}
56.1	6.611
60.3	7.179
64.8	7.770
69.2	8.293
74.2	8.815
80.2	9.349
84.2	9.681
94.5	1.046×10^{-1}
104.7	1.110
114.0	1.163
124.2	1.214
134.2	1.264
144.6	1.310
154.7	1.349
164.6	1.389
175.0	1.425
184.8	1.459
195.4	1.498
205.3	1.527
215.1	1.557
225.5	1.592
235.2	1.617
244.8	1.648
255.1	1.677
265.2	1.706
276.0	1.737
286.1	1.756
295.4	1.778

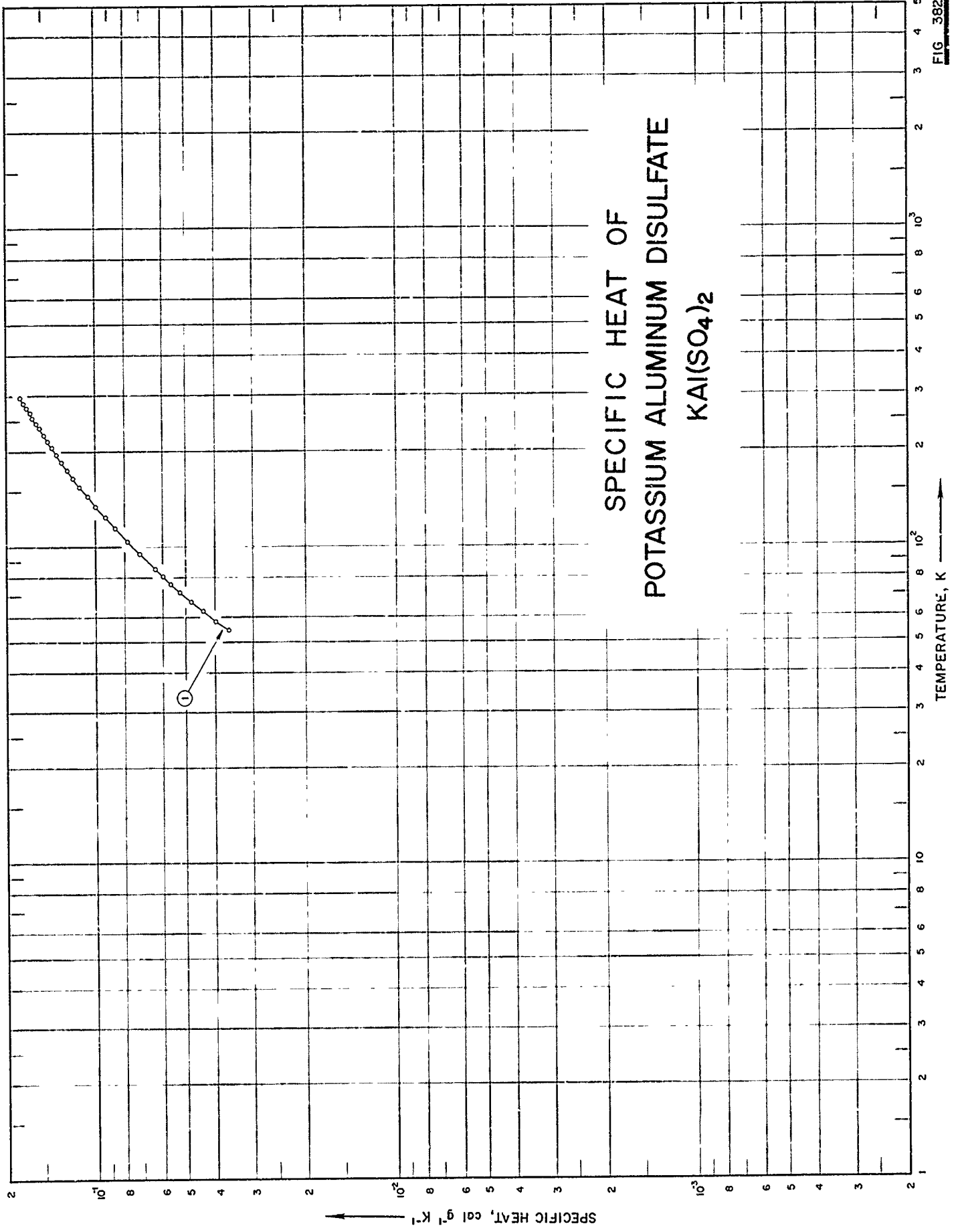

FIG. 382

SPECIFICATION TABLE NO. 382 SPECIFIC HEAT OF POTASSIUM ALUMINUM DISULFATE, $KAl(SO_4)_2$

[For Data Reported in Figure and Table No. 382]

Curve No.	Ref. No.	Year	Temp. Range, K	Reported Error, %	Name and Specimen Designation	Composition (weight percent), Specifications and Remarks
1	359	1946	55-297			19.65 Al_2O_3 (19.74 theo) and 0.3 H_2O .

DATA TABLE NO. 382 SPECIFIC HEAT OF POTASSIUM ALUMINUM DISULFATE, $KAl(SO_4)_2$ [Temperature, T, K; Specific Heat, C_p , Cal $g^{-1} K^{-1}$]

T	C_p
54.6	3.626×10^{-2}
58.4	4.009
6.28	4.423
67.3	4.849
71.9	5.271
76.4	5.662
80.6	6.019
85.1	6.371
95.0	7.161
104.6	7.893
115.0	8.660
124.2	9.307
134.9	1.004×10^{-1}
145.7	1.071
155.6	1.132
165.7	1.191
175.6	1.248
186.5	1.306
196.3	1.355
206.2	1.409
216.5	1.454
226.0	1.495
237.9	1.547
246.9	1.586
256.3	1.629
266.3	1.669
276.1	1.705
286.3	1.743
296.5	1.781

FIG. 383

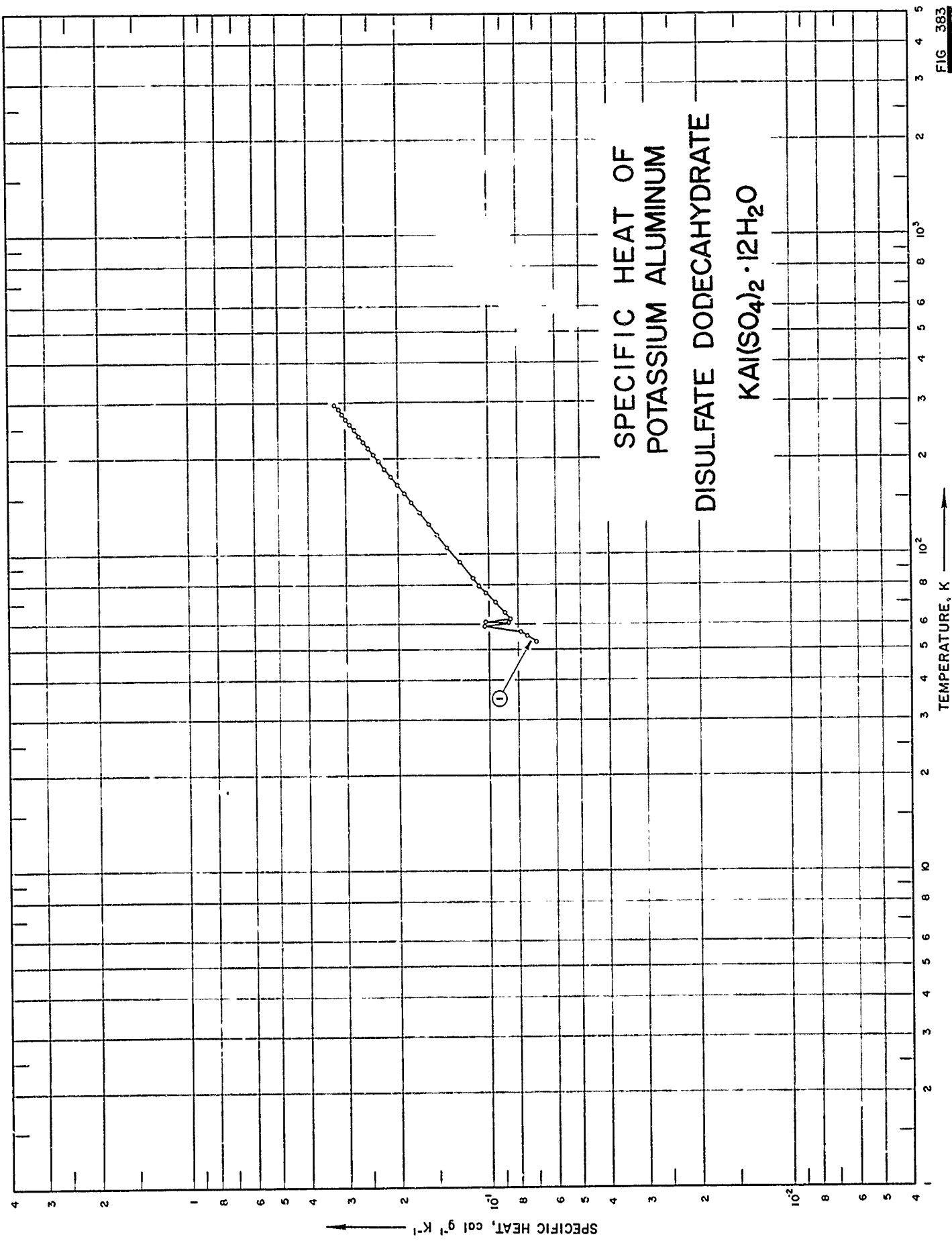

SPECIFICATION TABLE NO. 383 SPECIFIC HEAT OF POTASSIUM ALUMINUM DISULFATE DODECAHYDRATE, $KAl(SO_4)_2 \cdot 12H_2O$

[For Data Reported in Figure and Table No. 383]

Curve No.	Ref. No.	Year	Temp. Range, K	Reported Error, %	Name and Specimen Designation	Composition (weight percent), Specifications and Remarks
1	359	1946	53-296			10.74 Al_2O_3 and < 0.02 impurities.

DATA TABLE NO. 383 SPECIFIC HEAT OF POTASSIUM ALUMINUM DISULFATE DODECAHYDRATE, $\text{KAl}(\text{SO}_4)_2 \cdot 12\text{H}_2\text{O}$ [Temperature, T, K; Specific Heat, C_p , Cal $\text{g}^{-1}\text{K}^{-1}$]

T	C_p
CURVE 1	
52.7	7.001×10^{-2}
52.9	7.030*
55.3	7.490
56.7	4.920
57.5	8.055*
59.1	1.480×10^{-1}
60.6	8.696×10^{-2}
60.9	1.030×10^{-1}
62.3	8.544×10^{-2}
65.4	8.944
70.0	9.583
75.0	1.026×10^{-1}
79.4	1.003
83.9	1.137
94.6	1.265
104.6	1.380
115.0	1.495
124.2	1.596
135.0	1.713
145.6	1.822
155.5	1.923
165.4	2.023
175.6	2.131
185.5	2.228
196.0	2.334
205.8	2.428
216.4	2.538
226.0	2.634
235.6	2.711
246.1	2.810
256.0	2.911
265.9	3.000
276.1	3.090
286.0	3.168
296.1	3.261

* Not shown on plot

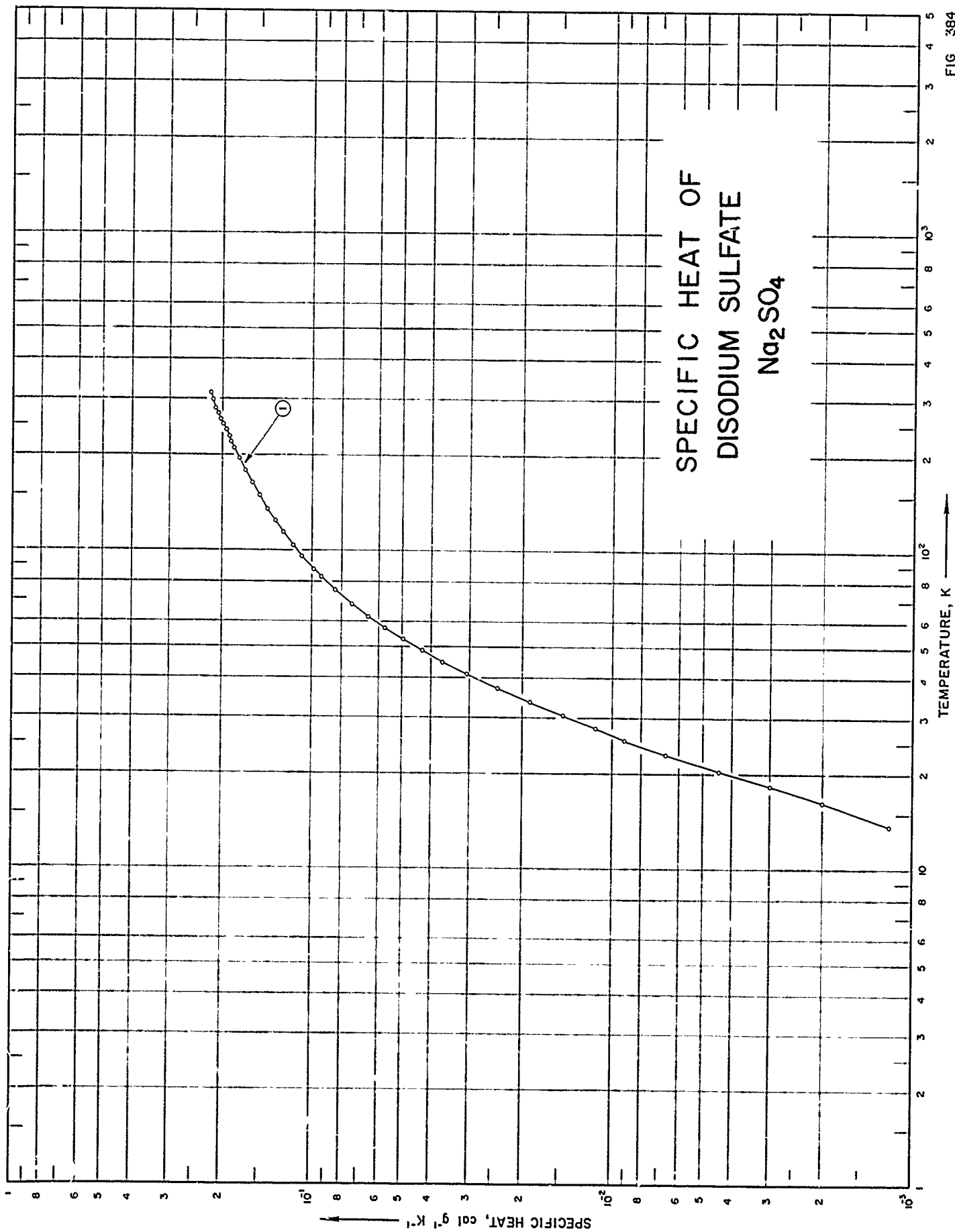

SPECIFICATION TABLE NO. 384 SPECIFIC HEAT OF DISODIUM SULFATE, Na_2SO_4

[For Data Reported in Figure and Table No. 384]

Curve No.	Ref. No.	Year	Temp. Range, K	Reported Error, %	Name and Specimen Designation	Composition (weight percent), Specifications and Remarks
1	447	1938	14-313			< 0.10 impurities; prepared by dehydration of decahydrate under vacuum at temperature below 80 C.

DATA TABLE NO. 384 SPECIFIC HEAT OF DISODIUM SULFATE, Na_2SO_4
 [Temperature, T, K; Specific Heat, C_p , Cal $\text{g}^{-1} \text{K}^{-1}$]

T	C_p
CURVE 1	
13.74	1.204×10^{-3}
16.25	2.014
18.30	2.999
20.43	4.407
23.04	6.611
25.48	9.068
27.73	1.137×10^{-2}
30.52	1.462
33.64	1.835
37.00	2.413
41.11	3.060
44.87	3.657
48.68	4.285
52.72	4.951
57.22	5.708
62.37	6.532
68.15	7.378
75.28	8.371
82.96	9.349
87.55	9.892
95.71	1.079×10^{-1}
104.51	1.166
114.59	1.255
125.07	1.337
136.41	1.420
149.18	1.502
163.42	1.588
179.41	1.675
195.80	1.752
211.35	1.830
220.40	1.875
229.90	1.905
240.09	1.945
250.48	1.993
259.96	2.023
270.37	2.062
281.19	2.102
292.14	2.128*
299.87	2.149
313.44	2.185

* Not shown on plot

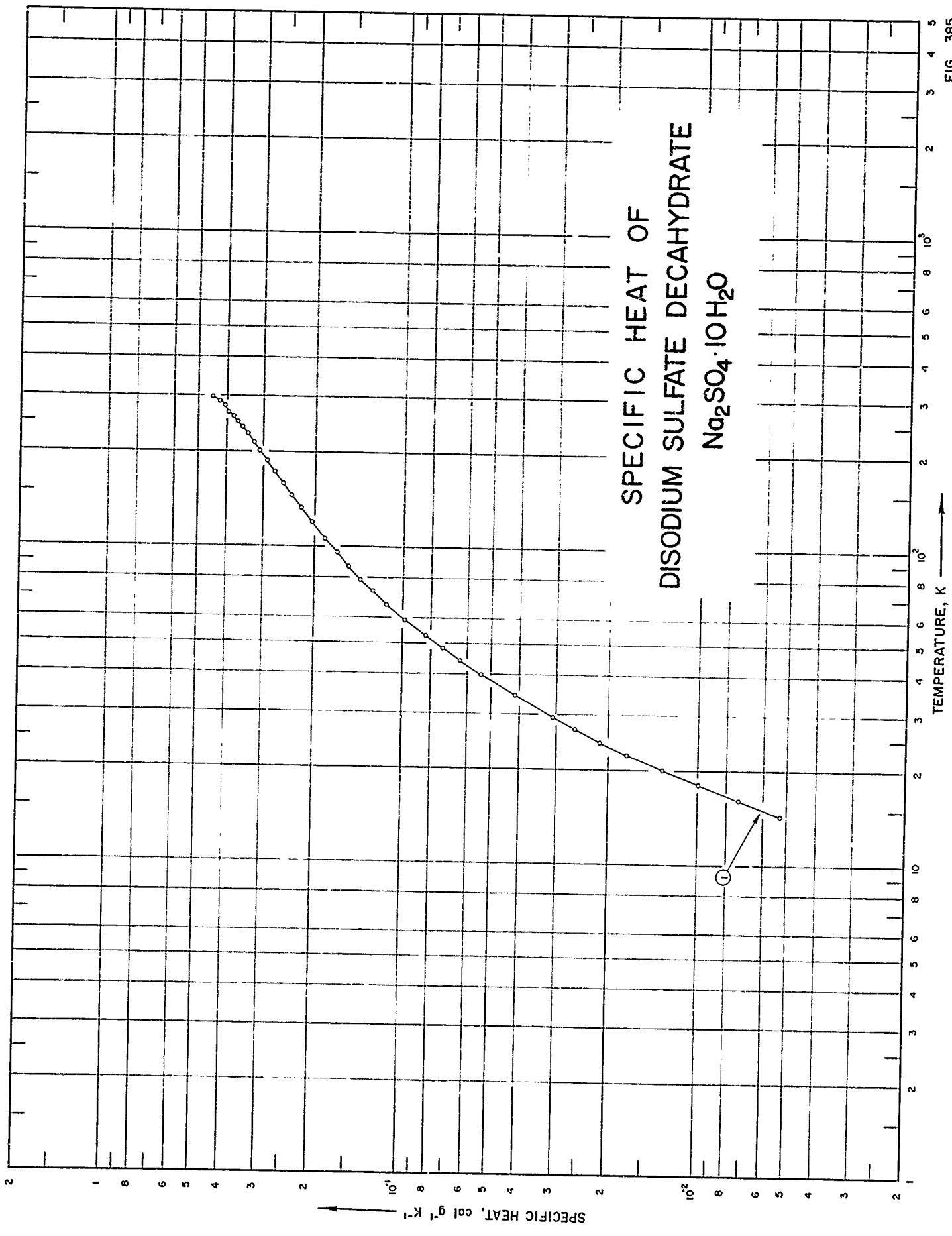

SPECIFICATION TABLE NO. 385 SPECIFIC HEAT OF DIODIUM SULFATE DECAHYDRATE, $\text{Na}_2\text{SO}_4 \cdot 10\text{H}_2\text{O}$

[For Data Reported in Figure and Table No. 385]

Curve No.	Ref. No.	Year	Temp. Range, K	Reported Error, %	Name and Specimen Designation	Composition (weight percent), Specifications and Remarks
1	447	1938	14-298			0.10 impurities; prepared by recrystallization of C. P. sodium sulfate decahydrate.

DATA TABLE NO. 385 SPECIFIC HEAT OF DISODIUM SULFATE DECAHYDRATE, $\text{Na}_2\text{SO}_4 \cdot 10\text{H}_2\text{O}$
 [Temperature, T, K; Specific Heat, C_p , Cal $\text{g}^{-1} \text{K}^{-1}$]

T	C_p
CURVE 1	
14.28	5.276×10^{-3}
16.15	7.294
18.11	9.963
20.08	1.322×10^{-2}
22.31	1.744
24.46	2.157
26.79	2.607
29.30	3.104
34.41	4.162
39.79	5.441
44.10	6.422
48.31	7.356
52.95	8.436
59.27	9.876
66.15	1.140×10^{-1}
72.77	1.273
79.42	1.400
86.95	1.534
96.36	1.682
107.29	1.863
120.45	2.052
133.91	2.244
145.99	2.415
158.58	2.578
173.01	2.757
187.67	2.925
201.77	3.119
215.55	3.259
228.56	3.420
239.83	3.557
249.98	3.693
259.33	3.818
266.87	3.982
281.21	4.094
289.83	4.261
298.37	4.528

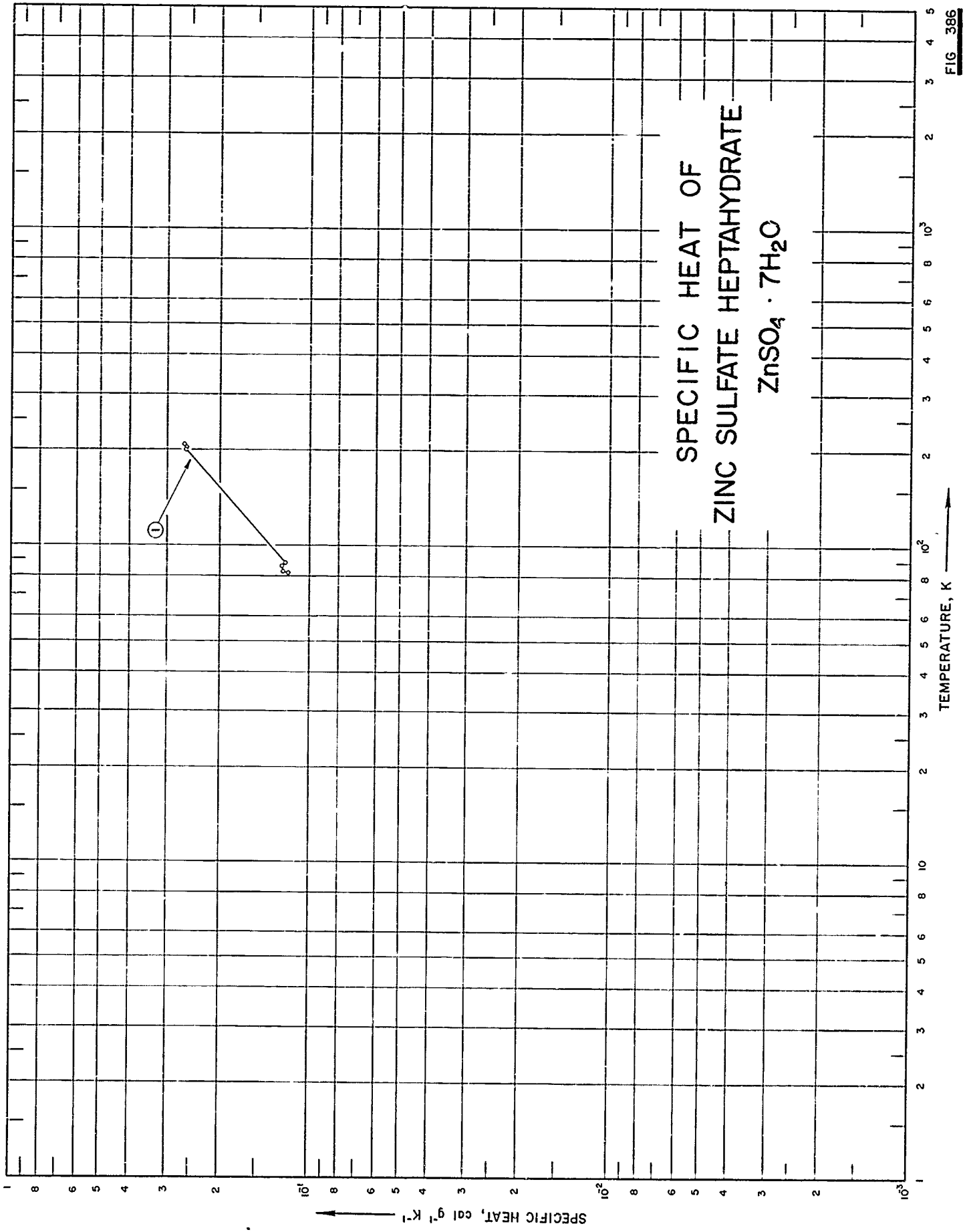

SPECIFICATION TABLE NO. 386 SPECIFIC HEAT OF ZINC SULFATE HEPTAHYDRATE, $ZnSO_4 \cdot 7H_2O$

[For Data Reported in Figure and Table No. 386]

Curve No.	Ref. No.	Year	Temp. Range, K	Reported Error, %	Name and Specimen Designation	Composition (weight percent), Specifications and Remarks
1	448	1911	82-208			

DATA TABLE NO. 386 SPECIFIC HEAT OF ZINC SULFATE HEPTAHYDRATE, $ZnSO_4 \cdot 7H_2O$
[Temperature, T, K. Specific Heat, C_p , Cal g⁻¹K⁻¹]

T	C_p
	<u>CURVE 1</u>
82.15	1.178 x 10 ⁻¹
83.15	1.229
86.15	1.233
88.15	1.214
201.15	2.601
204.15	2.597
208.15	2.636

FIG. 387

SPECIFIC HEAT OF ALUMINO SILICATE GLASS

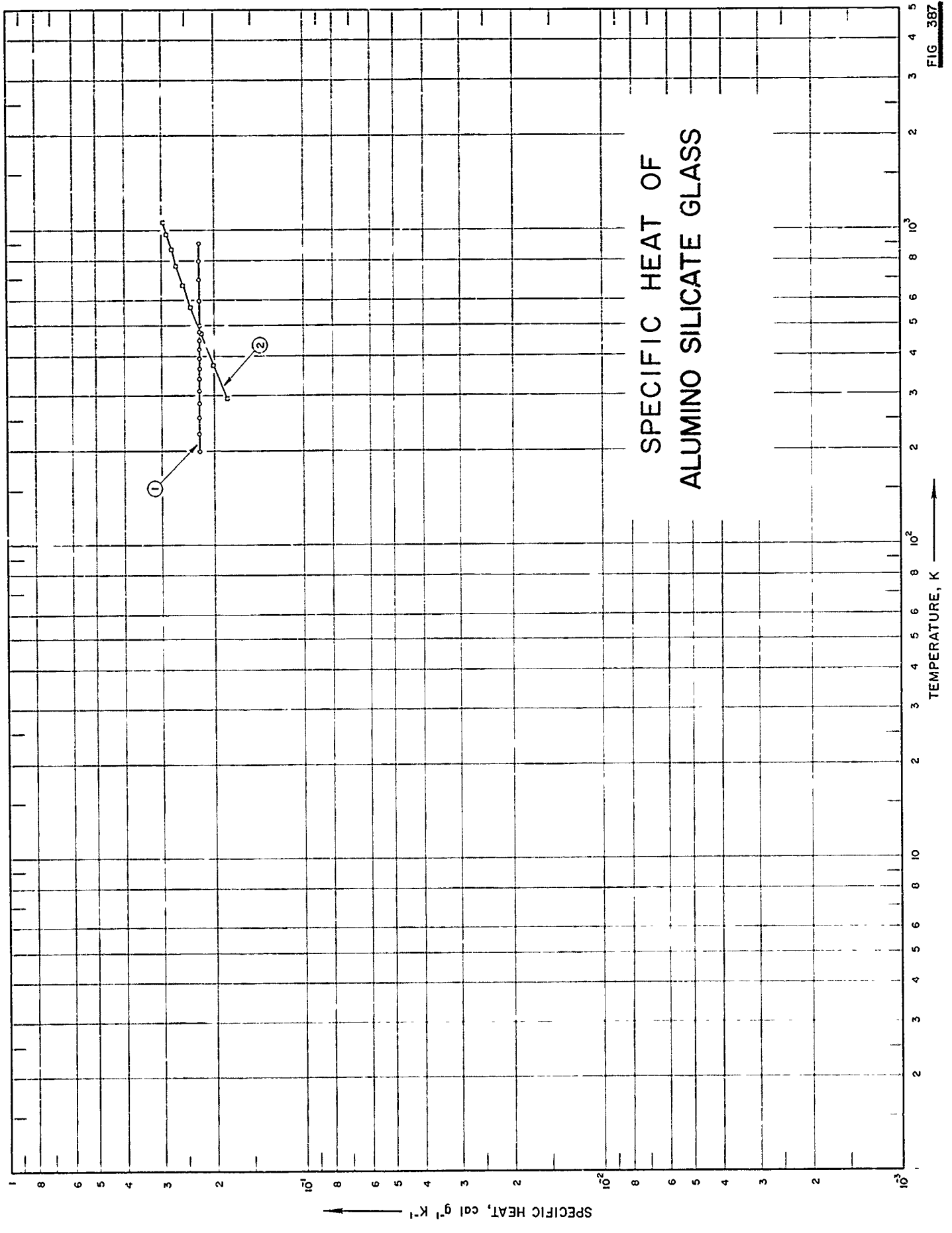

SPECIFICATION TABLE NO. 387 SPECIFIC HEAT OF ALUMINOSILICATE GLASS

[For Data Reported in Figure and Table No. 387]

Curve No.	Ref. No.	Year	Temp. Range, K	Reported Error, %	Name and Specimen Designation	Composition (weight percent), Specifications and Remarks
1	56	1958	200-912		Corning Glass, no. 1723	
2	344	1958	293-1073		Corning Glass, no. 1723	Density = 164.1 lb ft ⁻³ .

DATA TABLE NO. 387 SPECIFIC HEAT OF ALUMINOSILICATE GLASS

[Temperature, T, K; Specific Heat, Cp, Cal g⁻¹K⁻¹]

T	Cp
<u>CURVE 1</u>	
199.817	2.3 x 10 ⁻¹
227.039	2.3
255.372	2.3
283.16	2.3
310.94	2.3
338.72	2.3
366.49	2.3
394.27	2.3
422.05	2.3
449.83	2.3
477.60	2.3
912.05	2.3
<u>CURVE 2</u>	
293.15	1.80 x 10 ⁻¹
373.15	2.02
473.15	2.22
573.15	2.40
673.15	2.54
773.15	2.68
873.15	2.77
973.15	2.88
1073.15	2.97

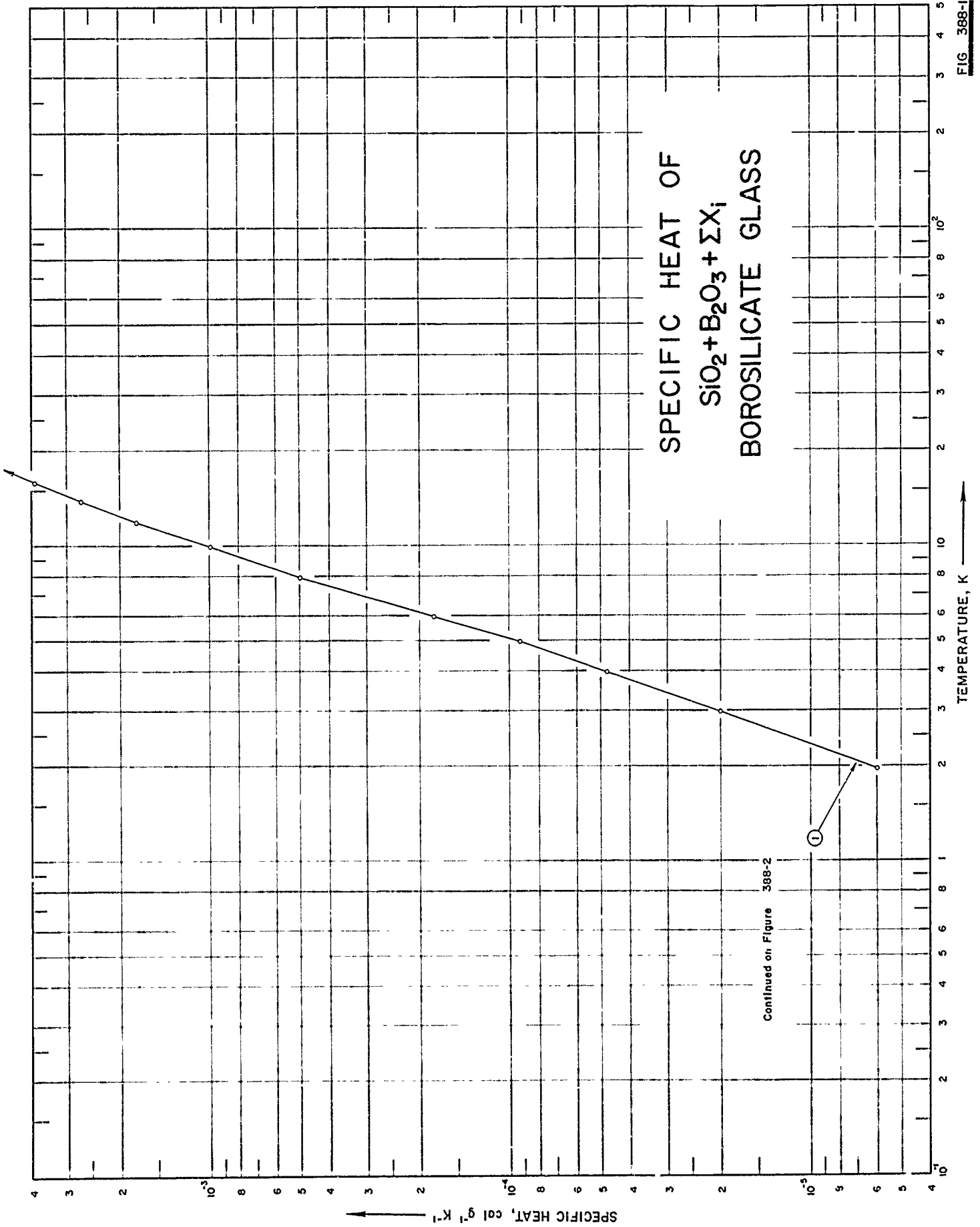
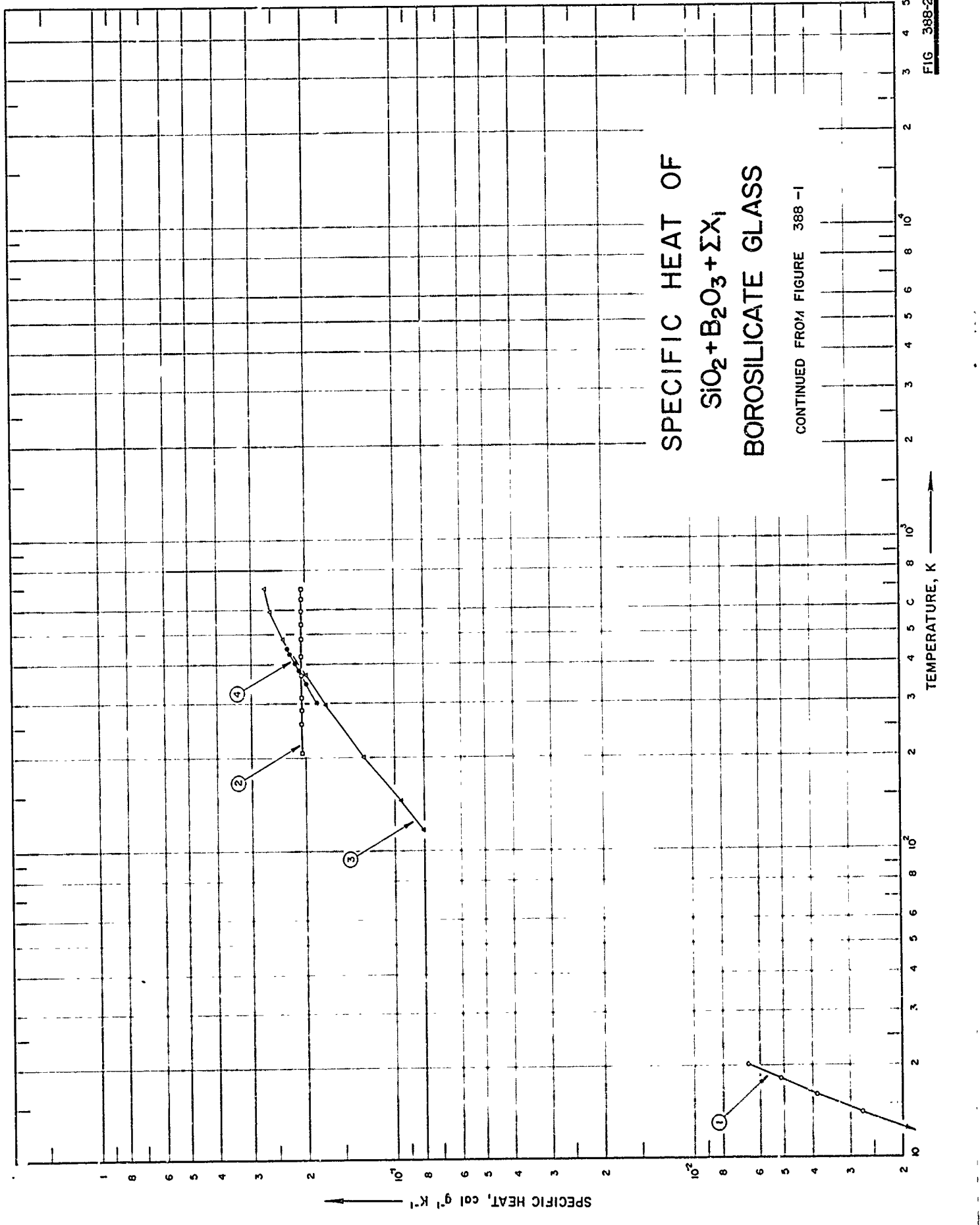

FIG. 398-1

SPECIFIC HEAT OF
 $\text{SiO}_2 + \text{B}_2\text{O}_3 + \Sigma \text{X}_i$
 BOROSILICATE GLASS

CONTINUED FROM FIGURE 388-1



SPECIFICATION TABLE NO. 388 SPECIFIC HEAT OF BOROSILICATE GLASS

[For Data Reported in Figure and Table No. 388]

Curve No.	Ref. No.	Year	Temp. Range, K	Reported Error, %	Name and Specimen Designation	Composition (weight percent). Specifications and Remarks
1	345	1956	2-20			
2	56	1958	206-691		Pittsburgh Plate Glass 3235	80 SiO ₂ , 14 B ₂ O ₃ , 4 Na ₂ O and 2 Al ₂ O ₃ .
3	9	1960	116-700	± 1.0	Pyrex Glass no. 774	40 SiO ₂ , 14 B ₂ O ₃ , 4 Na ₂ O and 2 Al ₂ O ₃ ; sample supplied by the Cincinnati Gasket and Packing Co; specimen sealed in helium atmosphere in a capsule; density = 138 lb ft ⁻³ at 32 F.
4	346	1930	300-145		Pyrex Glass	

DATA TABLE NO. 388 SPECIFIC HEAT OF BOROSILICATE GLASS

[Temperature, T, K; Specific Heat, Cp, Cal g⁻¹K⁻¹]

T	Cp
<u>CURVE 1</u>	
2	6.0 x 10 ⁻⁶
3	2.0 x 10 ⁻⁵
4	4.8
5	9.3
6	1.80 x 10 ⁻⁴
8	5.0
10	1.0 x 10 ⁻³
12	4.77
14	2.71
16	3.86
18	5.14
20	6.55
<u>CURVE 2</u>	
205.483	2.07 x 10 ⁻¹
255.372	2.07
283.16	2.07
310.94	2.07
366.49	2.07
422.05	2.07
477.60	2.07
533.16	2.07
588.72	2.07
644.27	2.07
691.49	2.07
<u>CURVE 3</u>	
116.483	8.1 x 10 ²
144.261	9.6
199.817	1.28 x 10 ⁻¹
293.16	1.72
366.49	2.02
477.60	2.38
588.72	2.66
699.83	2.75
<u>CURVE 4</u>	
299.55	1.859 x 10 ⁻¹
344.15	2.689
379.55	2.111
406.55	2.178
428.35	2.261
446.35	2.316

SPECIFIC HEAT OF
 $\text{SiO}_2 + \Sigma X_i$
HIGH SILICA GLASS

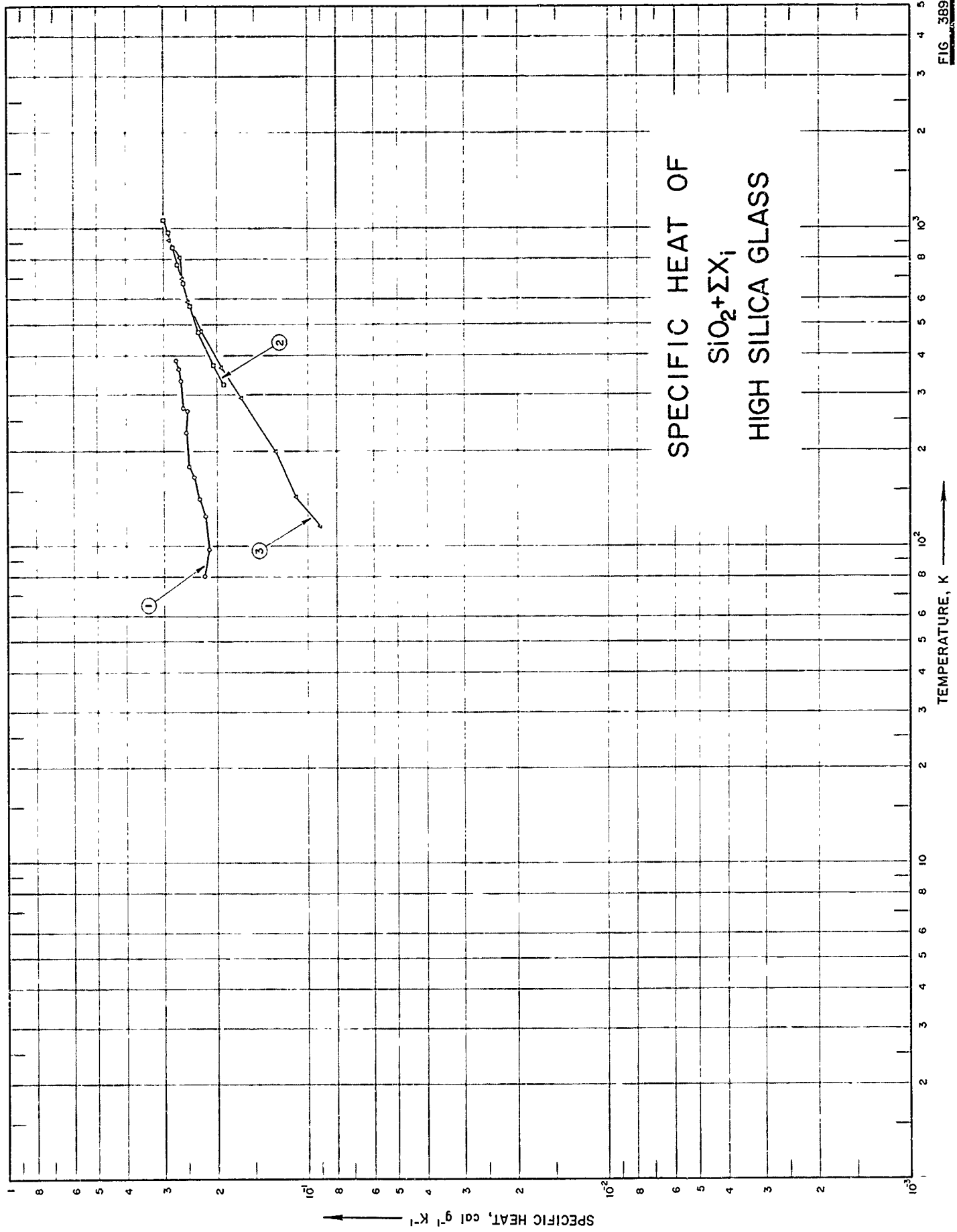

FIG. 389

SPECIFICATION TABLE NO. 389 SPECIFIC HEAT OF HIGH SILICA GLASS

[For Data Reported in Figure and Table No. 389]

Curve No.	Ref. No.	Year	Temp. Range, K	Reported Error, %	Name and Specimen Designation	Composition (weight percent), Specifications and Remarks
1	347	1955	81-387	8.0		High purity sample; powdered to pass a 40-mesh screen and retained on a 60-mesh, screen.
2	344	1958	323-1073		Vycor brand Clear High Silica 7900	$\geq 96 \text{ SiO}_2$, $\leq 3 \text{ B}_2\text{O}_3$ and other oxides; sample supplied by the Corning Glass Works; density = 136 lb ft^{-3} .
3	9	1960	116-922	± 1.0	Glass, Vycor	$\geq 96 \text{ SiO}_2$, $\leq 3 \text{ B}_2\text{O}_3$ and ≤ 1.0 other oxides; sample supplied by the Corning Glass Works; specimen sealed in helium atmosphere in a capsule; density = 136.5 lb ft^{-3} at 32 F.

DATA TABLE NO. 389 SPECIFIC HEAT OF HIGH SILICA GLASS
 [Temperature, T, K; Specific Heat, C_p , Cal g⁻¹ K⁻¹]

T C_p

CURVE 1

80.5	2.213×10^{-1}
97.9	2.130
125.0	2.196
142.0	2.296
166.0	2.379
179.0	2.479
229.0	2.529
268.0	2.512
274.0	2.596
336.0	2.646
363.0	2.679
387.0	2.745

CURVE 2

323.15	1.90×10^{-1}
373.15	2.06
473.15	2.30
575.15	2.45
673.15	2.59
773.15	2.71
873.15	2.81
973.15	2.91
1073.15	3.01

CURVE 3

116.483	9.1×10^{-2}
144.261	1.10×10^{-1}
199.817	1.28
293.16	1.67
366.49	1.93
477.60	2.26
588.72	2.49
699.83	2.60
810.94	2.66
922.05	2.88

FIG 390

SPECIFIC HEAT OF PYROCERAM

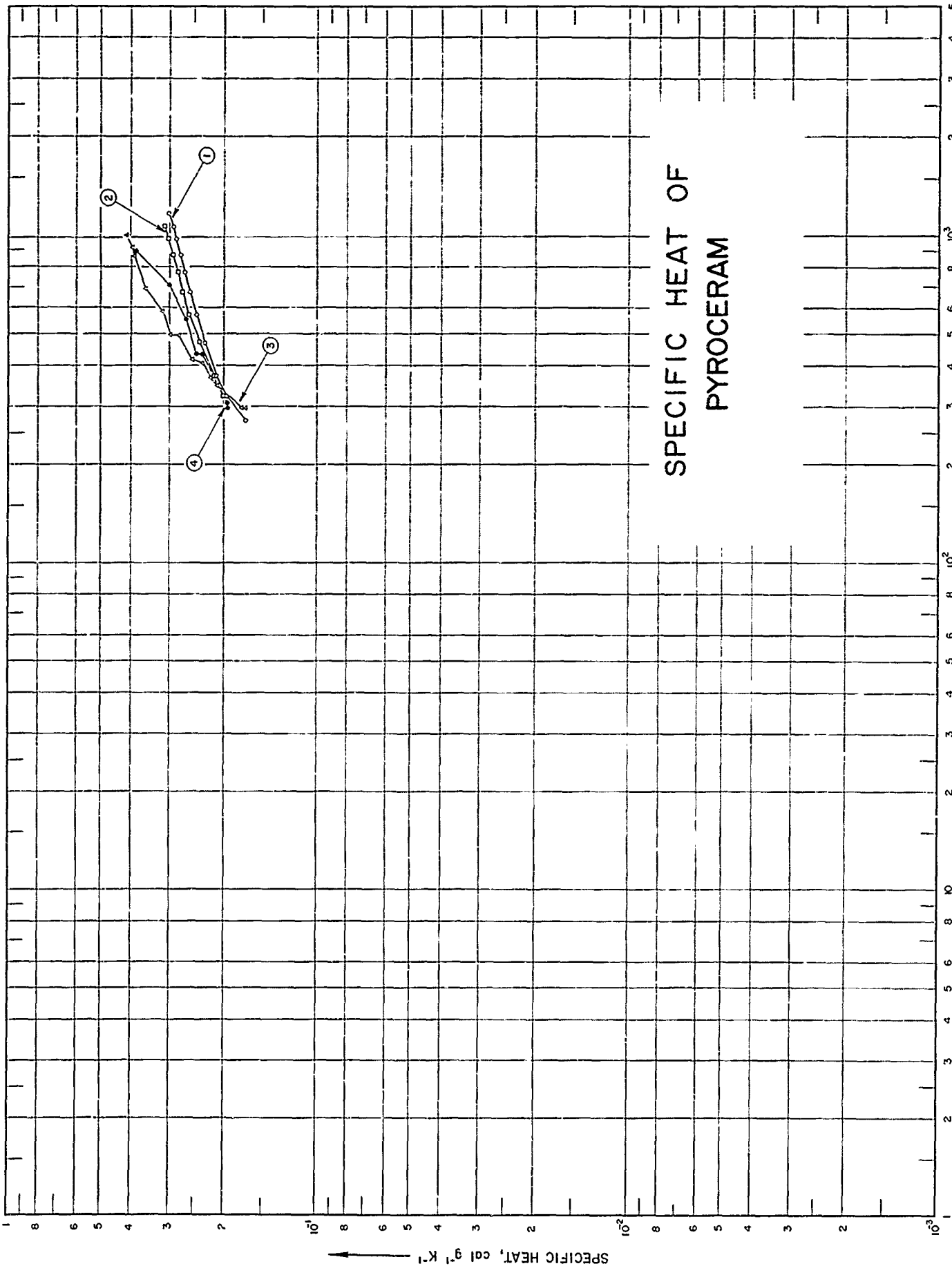

SPECIFIC HEAT, cal g⁻¹ K⁻¹

TEMPERATURE, K

SPECIFICATION TABLE NO. 390 SPECIFIC HEAT OF PYROCERAM

[For Data Reported in Figure and Table No. 390]

Curve No.	Ref. No.	Year	Temp. Range, K	Reported Error, %	Name and Specimen Designation	Composition (weight percent), Specifications and Remarks
1	344	1958	273-1173		no. 9606	Density = 162.3 lb ft ⁻³ .
2	344	1958	323-1073		no. 9608	Density = 156 lb ft ⁻³ .
3	348	1963	298-998		sample 1, no. 9608	Sample made by Corning Glass Works; coated with silver paste to make specimen opaque.
4	348	1963	298-893		sample 2, no. 9608	Same as above.

DATA TABLE NO. 390 SPECIFIC HEAT OF PYROCERAM

[Temperature, T, K; Specific Heat, Cp, Cal g⁻¹K⁻¹]

T	Cp	T	Cp
<u>CURVE 1</u>			
273.15	1.70 x 10 ⁻¹	298.15	1.94 x 10 ⁻¹
323.15	1.96	303.15	1.90*
373.15	2.12	308.15	1.95
473.15	2.31	435.15	2.35
573.15	2.46	435.15	2.46
673.15	2.58	555.15	2.66
773.15	2.68	704.15	3.00
873.15	2.76	893.15	3.86
973.15	2.84		
1073.15	2.92		
1173.15	3.01		
<u>CURVE 2</u>			
323.15	2.01 x 10 ⁻¹		
373.15	2.15		
473.15	2.40		
573.15	2.59		
673.15	2.71		
773.15	2.82		
873.15	2.93		
973.15	3.02		
1073.15	3.12		
<u>CURVE 3</u>			
298.15	1.70 x 10 ⁻¹		
298.15	1.75		
299.15	1.73*		
348.15	2.10		
369.15	2.22		
408.15	2.34		
418.15	2.55		
498.15	2.79		
498.15	2.98		
589.15	3.16		
589.15	3.20*		
688.15	3.59		
863.15	3.90		
918.15	3.95		
998.15	4.15		

* Not shown on plot

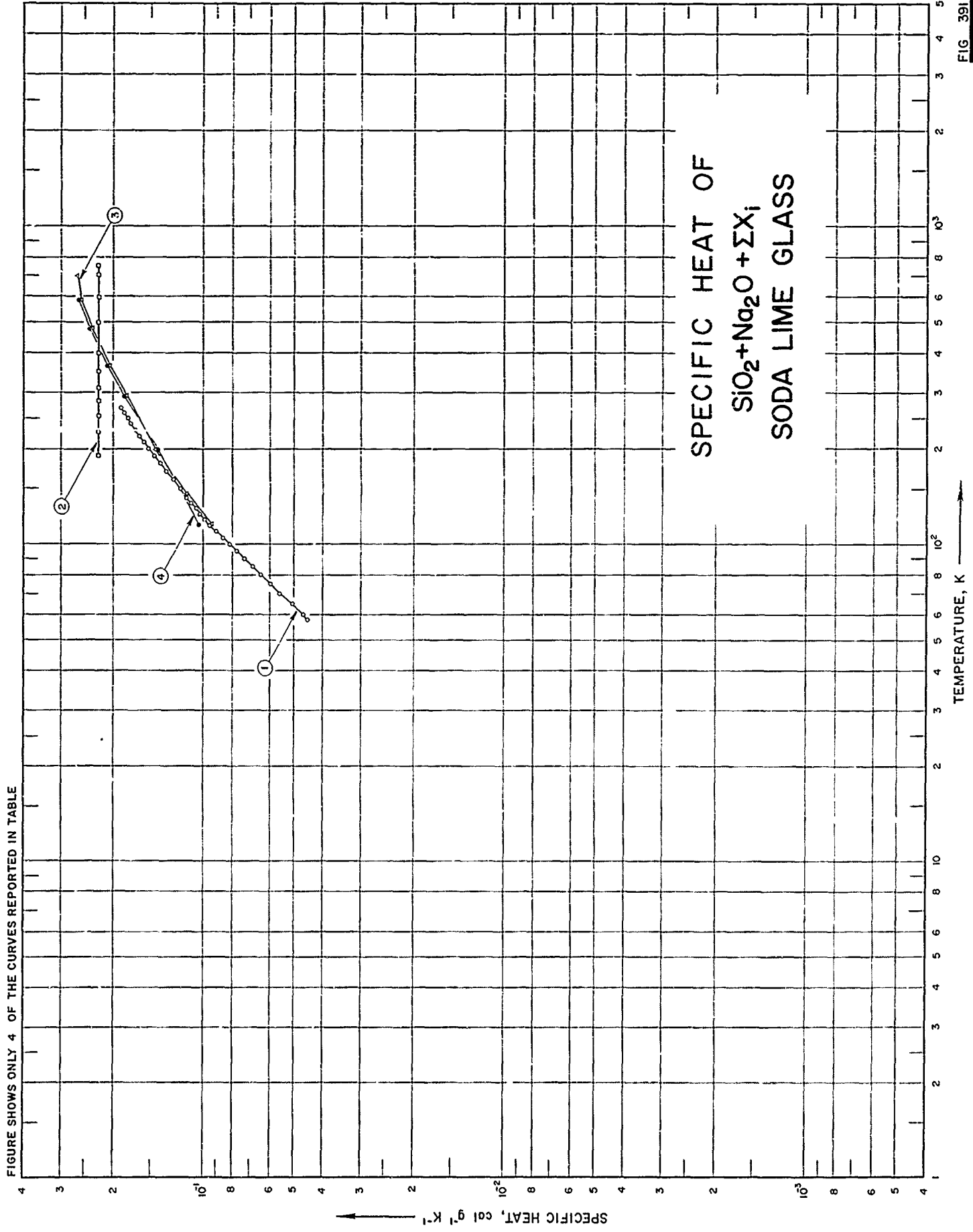

FIG 391

SPECIFICATION TABLE NO. 391 SPECIFIC HEAT OF SODA LIME GLASS

[For Data Reported in Figure and Table No. 391]

Curve No.	Ref. No.	Year	Temp. Range, K	Reported Error, %	Name and Specimen Designation	Composition (weight percent), Specifications and Remarks
1	349	1957	58-270		Glass no. 23	Nominal composition: 72 SiO ₂ , 15 Na ₂ O, 9 CaO, 3 MgO and 1 Al ₂ O ₃ ; commercially pure sample.
2	56	1958	191-753		Libby-Owens-Ford 9330	Nominal composition: 72 SiO ₂ , 15 Na ₂ O, 9 CaO, 3 MgO and 1 Al ₂ O ₃ ; soda-lime silica plate glass.
3	9	1960	116-700	± 1.0	Solex S	Nominal composition: 72 SiO ₂ , 15 Na ₂ O, 9 CaO, 3 MgO and 1 Al ₂ O ₃ ; sample supplied by the Pittsburgh Plate Glass Co; specimen sealed in helium atmosphere in capsule; density = 157 lb ft ⁻³ at 32 F.
4	9	1960	116-700	± 1.0	Solex 2808 X	Nominal composition: 72 SiO ₂ , 15 Na ₂ O, 9 CaO, 3 MgO and 1 Al ₂ O ₃ ; sample supplied by the Pittsburgh Plate Glass Co; specimen sealed in helium atmosphere in capsule; density = 158 lb ft ⁻³ at 32 F.
5	9	1960	116-700	± 1.0		Nominal composition: 72 SiO ₂ , 15 Na ₂ O, 9 CaO, 3 MgO and 1 Al ₂ O ₃ ; white (clear) plate glass; sample supplied by the Pittsburgh Plate Glass Co; specimen sealed in helium atmosphere in capsule; density = 157 lb ft ⁻³ at 32 F.

DATA TABLE NO. 391 SPECIFIC HEAT OF SODA LIME GLASS

[Temperature, T, K; Specific Heat, Cp, Cal g⁻¹K⁻¹]

T	Cp	T	Cp
<u>CURVE 1</u>			
58	4.50 x 10 ⁻²	191.483	2.24 x 10 ⁻¹
60	4.66	227.039	2.24
65	5.06	255.372	2.24
70	5.57	283.16	2.24
75	6.01	310.94	2.24
80	6.47	752.60	2.24
85	6.87	<u>CURVE 3</u>	
90	7.34	116.483	9.4 x 10 ⁻²
95	7.75	144.261	1.14 x 10 ⁻¹
100	8.18	199.817	1.44
105	8.62	293.16	1.81
110	9.06	366.49	2.06
115	9.52	477.60	2.36
120	9.86	588.72	2.57
125	1.027 x 10 ⁻¹	699.83	2.65
130	1.067	<u>CURVE 4</u>	
135	1.104	116.483	1.03 x 10 ⁻¹
140	1.141	144.261	1.16
145	1.171*	199.817	1.42
150	1.204	293.16	1.83
155	1.241*	366.49	2.08
160	1.271	477.60	2.38
165	1.302*	588.72	2.60
170	1.336	699.83	2.66*
175	1.365*	<u>CURVE 5</u>	
180	1.399	116.483	9.7 x 10 ⁻²
185	1.432*	144.261	1.14 x 10 ⁻¹
190	1.466	199.817	1.43
195	1.496*	293.16	1.82
200	1.526	366.49	2.07
205	1.552*	477.60	2.36
210	1.583	588.72	2.57
215	1.614*	699.83	2.68
220	1.640	<u>CURVE 1</u>	
225	1.661*	116.483	9.7 x 10 ⁻²
230	1.694	144.261	1.14 x 10 ⁻¹
235	1.721*	199.817	1.43
240	1.755	293.16	1.82
245	1.771*	366.49	2.07
250	1.798	477.60	2.36
255	1.822*	588.72	2.57
260	1.845	699.83	2.68
265	1.865*	<u>CURVE 1</u>	
270	1.885	116.483	9.7 x 10 ⁻²

* Not shown on plot

FIG. 392

SPECIFIC HEAT OF BERYLLIUM OXIDE + BERYLLIUM BeO + Be CERMET

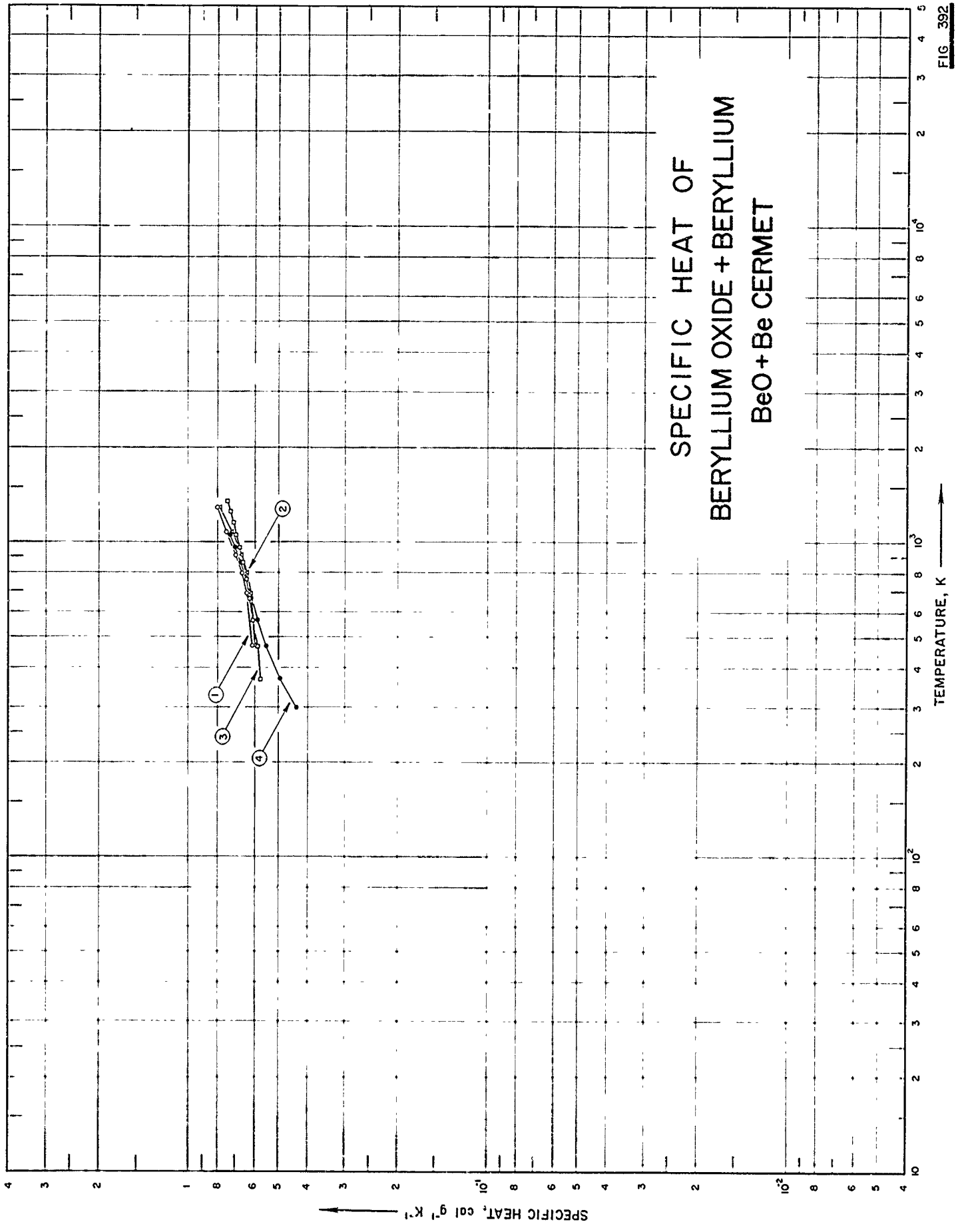

SPECIFICATION TABLE NO. 392 SPECIFIC HEAT OF BERYLLIUM + BERYLLIUM OXIDE, Be + BeO CERMET

[For Data Reported in Figure and Table No. 392]

Curve No.	Ref. No.	Year	Temp. Range, K	Reported Error, %	Name and Specimen Designation	Composition (weight percent), Specifications and Remarks
1	189	1958	478-1311	3.0	YB 9052	99.16 Be and 0.84 BeO.
2	189	1958	478-1311	3.0	YB 9054	98.32 Be and 1.68 BeO.
3	350	1960	373-1373	±2.7	QMV Beryllium	Impurities: 1.16 BeO, 0.15 Al, 0.13 Mg, 0.1 Fe, 0.1 Ni and others; sample manufactured by the Brush Beryllium Corp.
4	45	1962	303-1075	±3.0		99.3 Be, 0.9 BeO, 0.1 Fe and 0.1 various metals.

DATA TABLE NO. 392 SPECIFIC HEAT OF BERYLLIUM + BERYLLIUM OXIDE, Be + BeO CERMET
 [Temperature, T, K; Specific Heat, C_p , Cal g⁻¹ K⁻¹]

T	C_p
<u>CURVE 1</u>	
478	6.150×10^{-1}
700	6.410
811	6.670
922	6.990
1089	7.490
1311	8.040
<u>CURVE 2</u>	
478	6.050×10^{-1}
700	6.230
811	6.440
922	6.720
1089	7.220
1311	7.940
<u>CURVE 3</u>	
373	5.780×10^{-1}
473	5.940
573	6.110
673	6.280
773	6.440
873	6.610
973	6.780
1073	6.950
1173	7.110
1273	7.280
1373	7.450
<u>CURVE 4</u>	
303	4.37×10^{-1}
375	4.98
475	5.53
575	5.91
675	6.20
775	6.47*
875	6.74
975	7.01
1075	7.29

* Not shown on plot

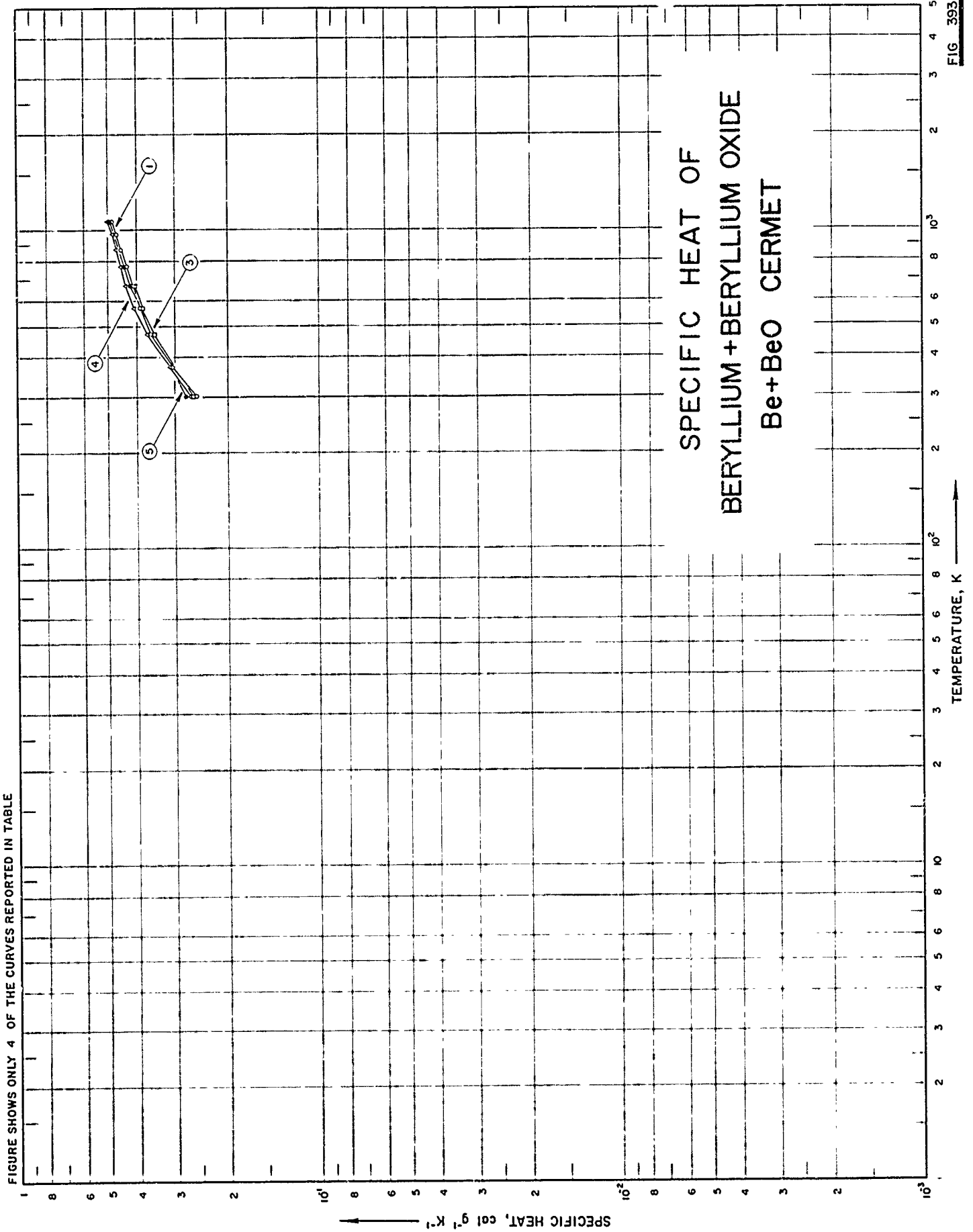

SPECIFICATION TABLE NO. 393 SPECIFIC HEAT OF BERYLLIUM OXIDE + BERYLLIUM. BeO + Be CERMET
 [For Data Reported in Figure and Table No. 393]

Curve No.	Ref. No.	Year	Temp. Range, K	Reported Error, %	Name and Specimen Designation	Composition (weight percent), Specifications and Remarks
1	45	1962	303-1075	< 3.0		Nominal composition: 97 BeO and 3 Be.
2	45	1962	303-1073	< 3.0		Nominal composition: 94 BeO and 6 Be.
3	45	1962	303-1073	< 3.0		Nominal composition: 93 BeO and 7 Be.
4	45	1962	303-1073	< 3.0		Nominal composition: 91 BeO and 9 Be.
5	45	1962	303-1073	< 3.0		Nominal composition: 88 BeO and 12 Be.

DATA TABLE NO. 393 SPECIFIC HEAT OF BERYLLIUM OXIDE + BERYLLIUM, BeO + Be CERNIFT
 [Temperature, T, K; Specific Heat, C_p , Cal g⁻¹K⁻¹]

T	C_p	T	C_p
<u>CURVE 1</u>			
303	2.54 x 10 ⁻¹	303	2.75 x 10 ⁻¹
373	3.05	373	3.13*
475	3.60	473	3.62*
575	3.92	573	3.95*
675	4.14	673	4.20
775	4.34	773	4.41
875	4.51	873	4.57*
975	4.68	973	4.73*
1075	4.85	1073	4.90
<u>CURVE 2</u>			
303	2.62 x 10 ⁻¹		
373	3.06		
473	3.58		
573	3.94		
673	4.16		
773	4.36		
873	4.54		
973	4.72		
1073	4.91		
<u>CURVE 3</u>			
303	2.61 x 10 ⁻¹		
373	3.03*		
473	3.49		
573	3.84		
673	4.08		
773	4.30*		
873	4.50*		
973	4.68*		
1073	4.86*		
<u>CURVE 4</u>			
303	2.65 x 10 ⁻¹		
373	3.11		
473	3.70		
573	4.11		
673	4.36		
773	4.53		
873	4.69		
973	4.83		
1073	5.01		

* Not shown on plot

FIG. 394

SPECIFIC HEAT OF
BERYLLIUM OXIDE +
BERYLLIUM + MOLYBDENUM
BeO + Be + Mo CERMET

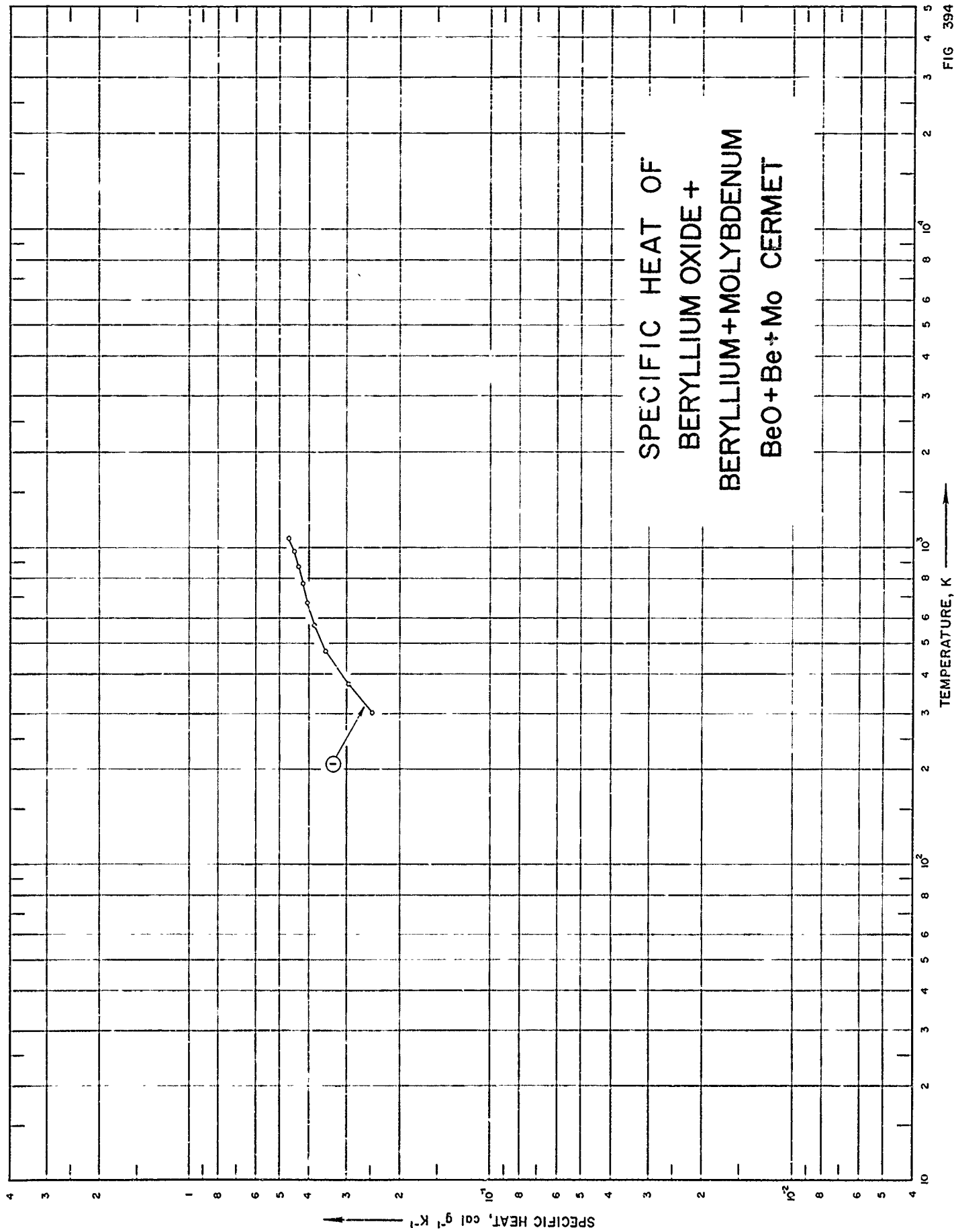

SPECIFICATION TABLE NO. 394 SPECIFIC HEAT OF BERYLLIUM OXIDE + BERYLLIUM + MOLYBDENUM, BeO + Be + Mo CERMET
 [For Data Reported in Figure and Table No. 394]

Curve No.	Ref. No.	Year	Temp. Range, K	Reported Error, %	Name and Specimen Designation	Composition (weight percent), Specifications and Remarks
1	45	1962	303-1073	< 3.0		Nominal composition: 88 BeO, 7 Be and 7 Mo.

DATA TABLE NO. 394 SPECIFIC HEAT OF BERYLLIUM OXIDE + BERYLLIUM + MOLYBDENUM. BeO + Be + Mo CERMET
[Temperature, T, K; Specific Heat, C_p , Cal g⁻¹ K⁻¹]

T	C_p
<u>CURVE 1</u>	
303	2.48 x 10 ⁻¹
373	2.97
473	3.56
573	3.87
673	4.07
773	4.23
873	4.38
973	4.54
1073	4.70

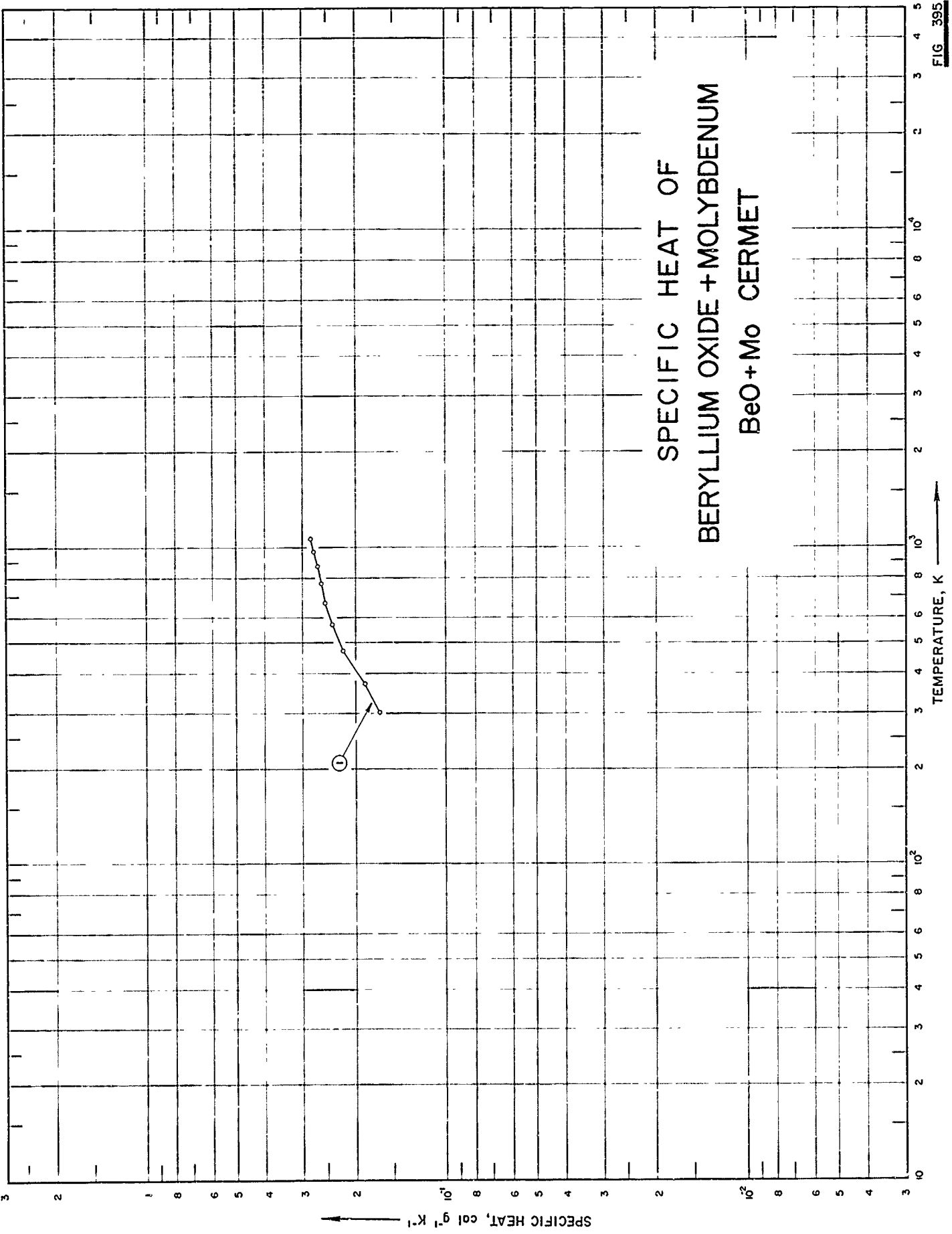

FIG 395

SPECIFICATION TABLE NO. 395 SPECIFIC HEAT OF BERYLLIUM OXIDE + MOLYBDENUM, BeO + Mo CERMET

[For Data Reported in Figure and Table No. 395]

Curve No.	Ref. No.	Year	Temp. Range, K	Reported Error, %	Name and Specimen Designation	Composition (weight percent), Specifications and Remarks
1	45	1962	303-1073	< 3.0		57.6 BeO and 42.4 Mo.

DATA TABLE NO. 395 SPECIFIC HEAT OF BERYLLIUM OXIDE + MOLYBDENUM, BeO + Mo CERMET
[Temperature, T, K; Specific Heat, C_p , Cal $g^{-1} K^{-1}$]

T	C_p
<u>CURVE 1</u>	
303	1.68×10^{-1}
373	1.88
473	2.23
573	2.42
673	2.55
773	2.63
873	2.70
973	2.78
1073	2.85

FIG. 396

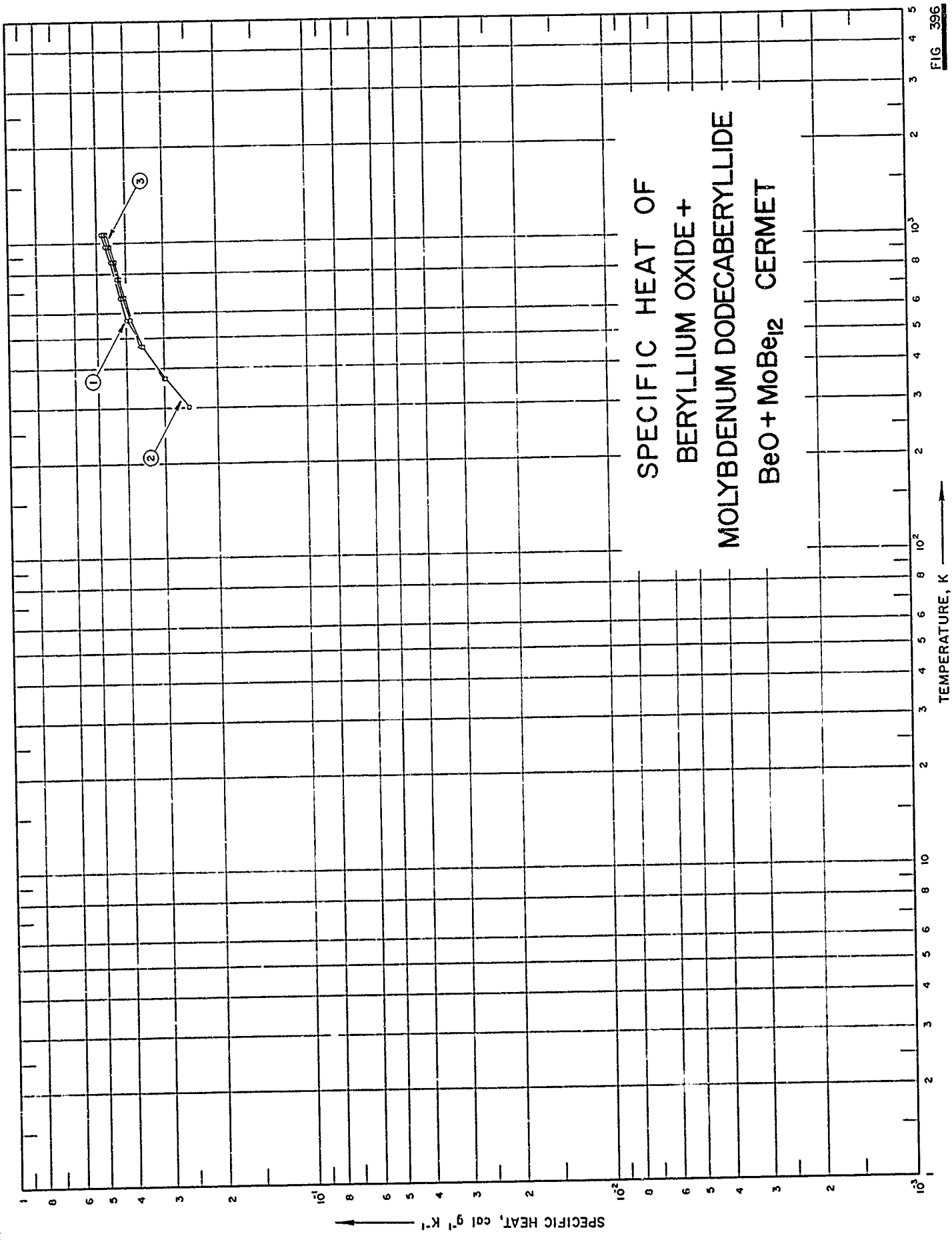

SPECIFICATION TABLE NO. 396 SPECIFIC HEAT OF BERYLLIUM OXIDE + MOLYBDENUM DODECABERYLLIDE, BeO + MoBe₂ CERMET
 [For Data Reported in Figure and Table No. 396]

Curve No.	Ref. No.	Year	Temp. Range, K	Reported Error, %	Name and Specimen Designation	Composition (weight percent), Specifications and Remarks
1	45	1962	303-1073	< 3.0		Nominal composition: 94 BeO and 6 MoBe ₂ .
2	45	1962	303-1073	< 3.0		Nominal composition: 94 BeO and 9 MoBe ₂ .
3	45	1962	303-1073	< 3.0		Nominal composition: 82 BeO and 18 MoBe ₂ .

DATA TABLE NO. 396 SPECIFIC HEAT OF BERYLLIUM OXIDE + MOLYBDENUM DODECABERYLLIDE, BeO + MoBe₁₂ CERMET
 [Temperature, T, K; Specific Heat, C_p, Cal g⁻¹ K⁻¹]

T	C _p
<u>CURVE 1</u>	
303	2.49 x 10 ^{-1*}
373	3.00
473	3.60*
573	3.99
673	4.17
773	4.34
873	4.51
973	4.68
1073	4.84
<u>CURVE 2</u>	
303	2.49 x 10 ⁻¹
373	2.98
473	3.56
573	3.89
673	4.12
773	4.28
873	4.44
973	4.60
1073	4.75
<u>CURVE 3</u>	
303	2.50 x 10 ^{-1*}
373	2.99*
473	3.62
573	3.92*
673	4.07
773	4.23
873	4.38
973	4.54
1073	4.70

* Not shown on plot

SPECIFIC HEAT OF
BERYLLIUM OXIDE +
NIOBIUM DODECABERYLLIDE
BeO + NbBe₁₂ CERMET

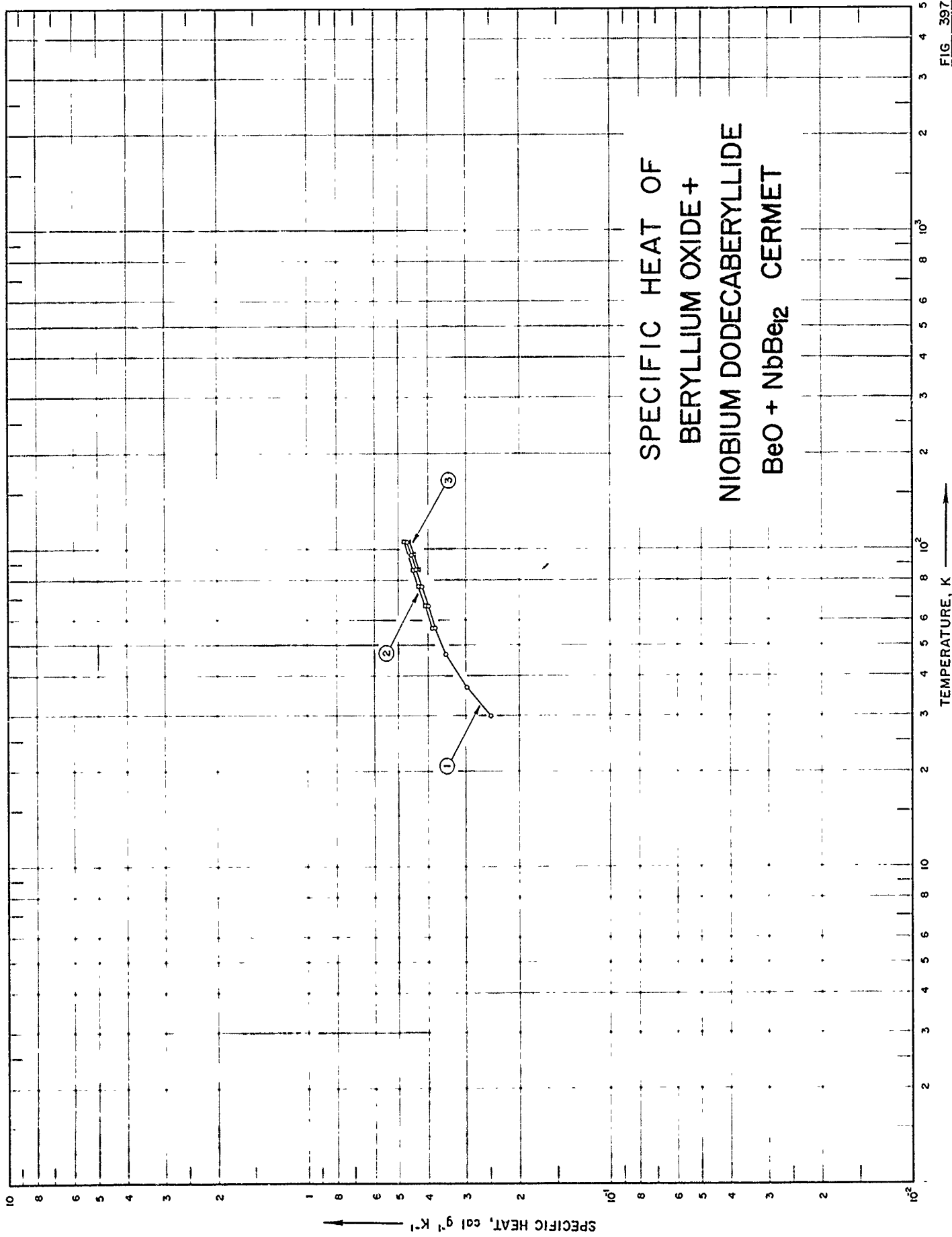

FIG 397

SPECIFICATION TABLE NO. 397 SPECIFIC HEAT OF BERYLLIUM OXIDE + NIOBIUM DODECABERYLLIDE, BeO + NbBe₁₂ CERMET

[For Data Reported in Figure and Table No. 397]

Curve No.	Ref. No.	Year	Temp. Range, K	Reported Error, %	Name and Specimen Designation	Composition (weight percent), Specifications and Remarks
1	45	1962	303-1073	< 3.0		Nominal composition: 94 BeO and 6 NbBe ₁₂ .
2	45	1962	303-1073	< 3.0		Nominal composition: 91 BeO and 9 NbBe ₁₂ .
3	45	1962	303-1073	< 3.0		Nominal composition: 82 BeO and 18 NbBe ₁₂ .

DATA TABLE NO. 397 SPECIFIC HEAT OF BERYLLIUM OXIDE + NIOBIUM DODECABERYLLIDE, BeO + NbBe₁₂ CERMET[Temperature, T, K; Specific Hea., C_p, Cal g⁻¹ K⁻¹]

T	C _p
<u>CURVE 1</u>	
303	2.49 x 10 ⁻¹
373	2.99
473	3.52
573	3.83
673	4.04
773	4.24
873	4.41
973	4.56
1073	4.74
<u>CURVE 2</u>	
303	2.49 x 10 ⁻¹ *
373	2.99*
473	3.53*
573	3.89
673	4.12
773	4.32
873	4.48
973	4.64
1073	4.80
<u>CURVE 3</u>	
303	2.51 x 10 ⁻¹ *
373	2.98*
473	3.52*
573	3.87
673	4.03*
773	4.19*
873	4.34
973	4.49
1073	4.66

* Not shown on plot

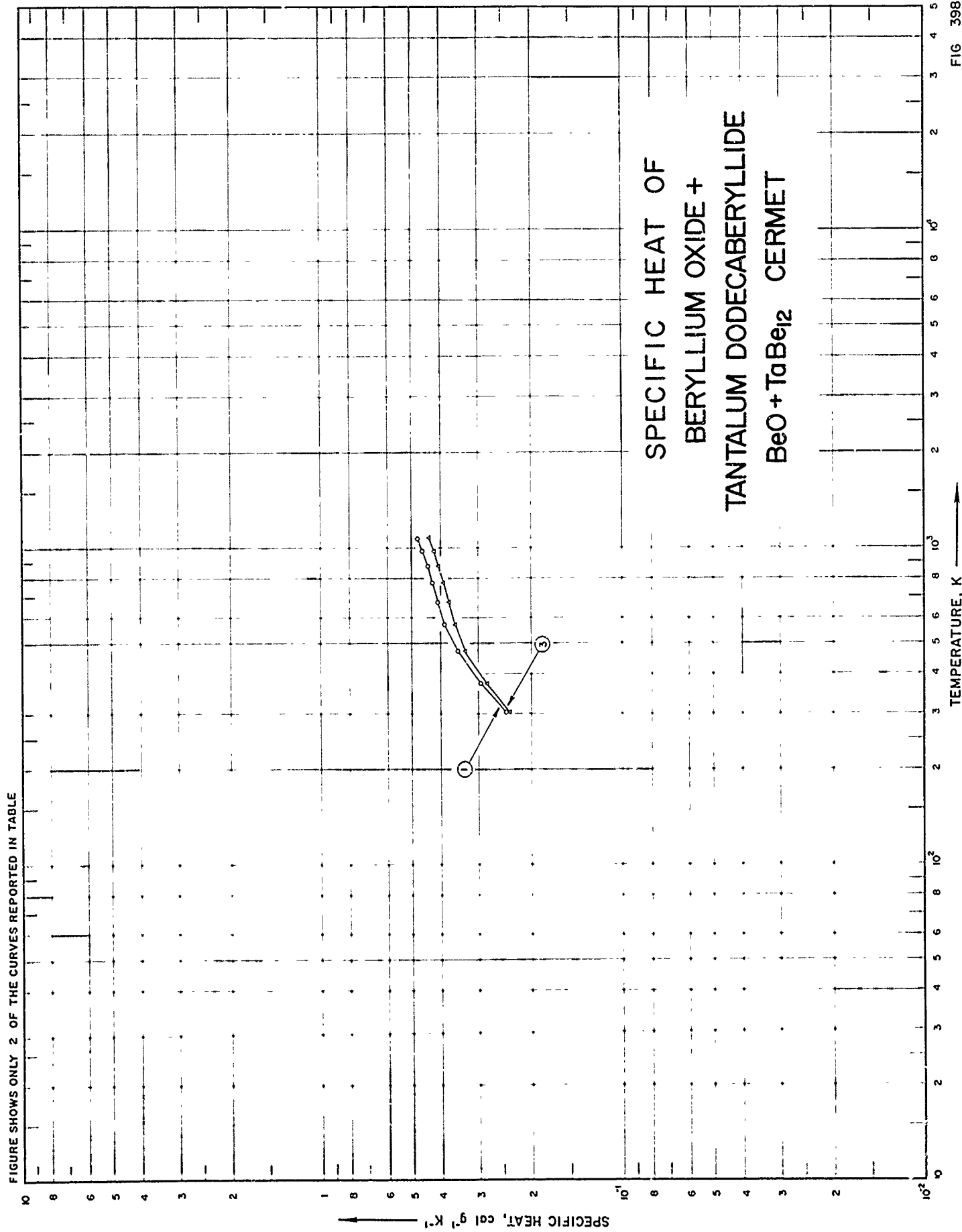

FIGURE SHOWS ONLY 2 OF THE CURVES REPORTED IN TABLE

SPECIFICATION TABLE NO. 398 SPECIFIC HEAT OF BERYLLIUM OXIDE + TANTALUM DODECABERYLLIDE, BeO + TaBe₁₂ CERMET

[For Data Reported in Figure and Table No. 398]

Curve No.	Ref. No.	Year	Temp. Range, K	Reported Error, %	Name and Specimen Designation	Composition (weight percent), Specifications and Remarks
1	45	1962	303-1073	< 3.0		Nominal composition: 94 BeO and 6 TaBe ₂ .
2	45	1962	303-1073	< 3.0		Nominal composition: 91 BeO and 9 TaBe ₂ .
3	45	1962	303-1073	< 3.0		Nominal composition: 82 BeO and 18 TaBe ₂ .

DATA TABLE NO. 398 SPECIFIC HEAT OF BERYLLIUM OXIDE + TANTALUM DODECABERYLLIDE, BeO + TaBe₁₂ CERMET[Temperature, T, K; Specific Heat, C_p, Cal g⁻¹ K⁻¹]

T	C _p
<u>CURVE 1</u>	
303	2.44 x 10 ⁻¹
373	2.94
473	3.50
573	3.88
673	4.08
773	4.26
873	4.43
973	4.60
1073	4.77
<u>CURVE 2*</u>	
303	2.42 x 10 ⁻¹
373	3.02
473	3.55
573	3.88
673	4.10
773	4.28
873	4.44
973	4.59
1073	4.74
<u>CURVE 3</u>	
303	2.37 x 10 ⁻¹
373	2.82
473	3.31
573	3.58
673	3.75
773	3.90
873	4.06
973	4.22
1073	4.38

* Not shown on plot

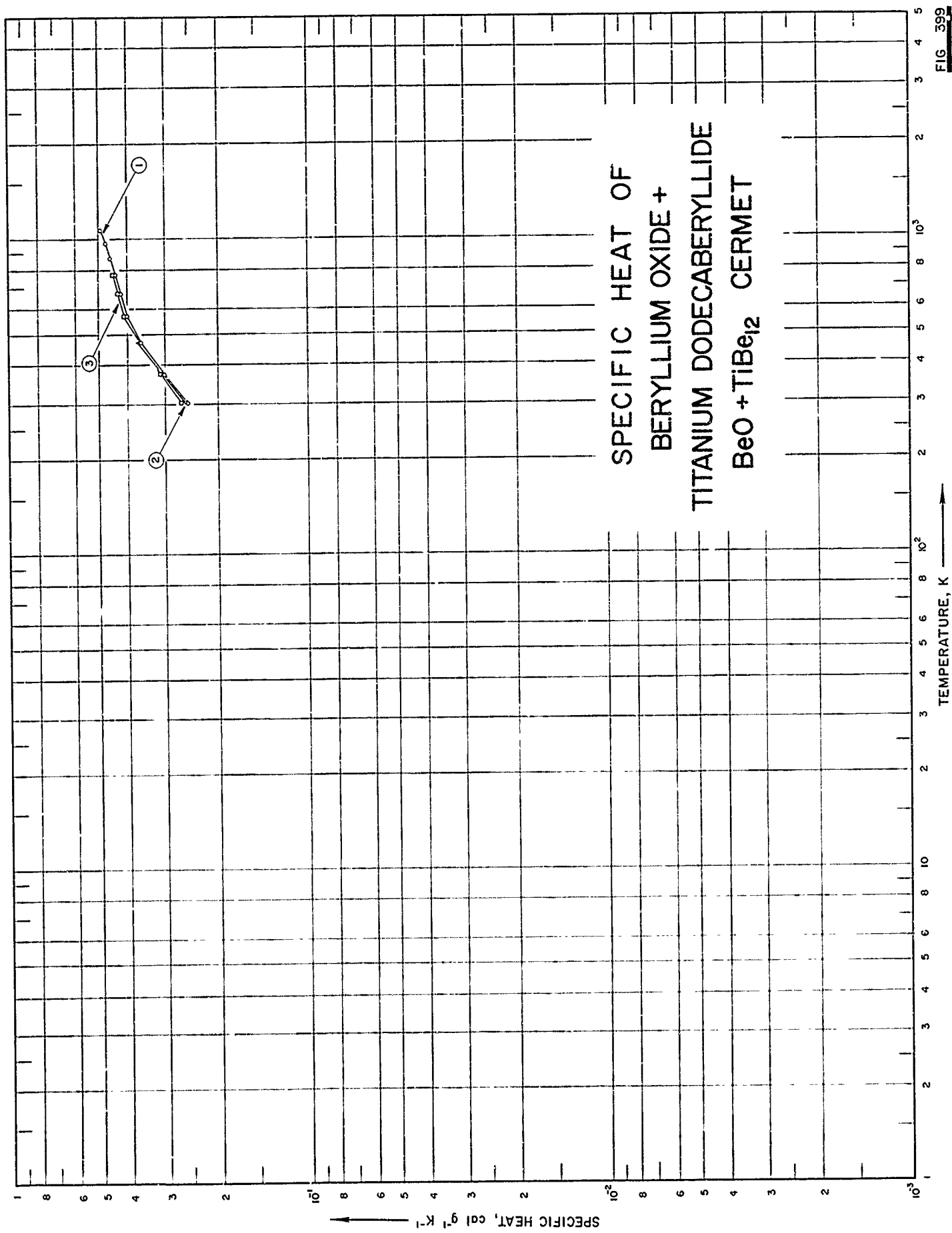

SPECIFICATION TABLE NO. 399 SPECIFIC HEAT OF BERYLLIUM OXIDE + TITANIUM DODECABERYLLIDE, BeO + TiBe₂ CERMET

[For Data Reported in Figure and Table No. 399]

Curve No.	Ref. No.	Year	Temp. Range, K	Reported Error, %	Name and Specimen Designation	Composition (weight percent), Specifications and Remarks
1	45	1962	303-1073	< 3.0		Nominal composition: 94 BeO and 6 TiBe ₂ .
2	45	1962	303-1073	< 3.0		Nominal composition: 91 BeO and 9 TiBe ₂ .
3	45	1962	303-1073	< 3.0		Nominal composition: 82 BeO and 18 TiBe ₂ .

DATA TABLE NO. 399 SPECIFIC HEAT OF BERYLLIUM OXIDE + TITANIUM DODECABERYLLIDE, BeO + TiBe₁₂ CERNET
 [Temperature, T, K; Specific Heat, C_p, Cal g⁻¹ K⁻¹]

T	C _p
<u>CURVE 1</u>	
303	2.53 x 10 ⁻¹
373	3.04
473	3.61
573	4.01
673	4.22
773	4.39
873	4.56
973	4.73
1073	4.90
<u>CURVE 2</u>	
303	2.56 x 10 ⁻¹
373	3.09
473	3.66
573	4.01 [*]
673	4.23 [*]
773	4.41 [*]
873	4.59 [*]
973	4.75 [*]
1073	4.93 [*]
<u>CURVE 3</u>	
303	2.65 x 10 ⁻¹
373	3.10
473	3.65 [*]
573	4.10
673	4.30
773	4.46
873	4.62 [*]
973	4.78 [*]
1073	4.94 [*]

^{*} Not shown on plot

FIGURE SHOWS ONLY 2 OF THE CURVES REPORTED IN TABLE

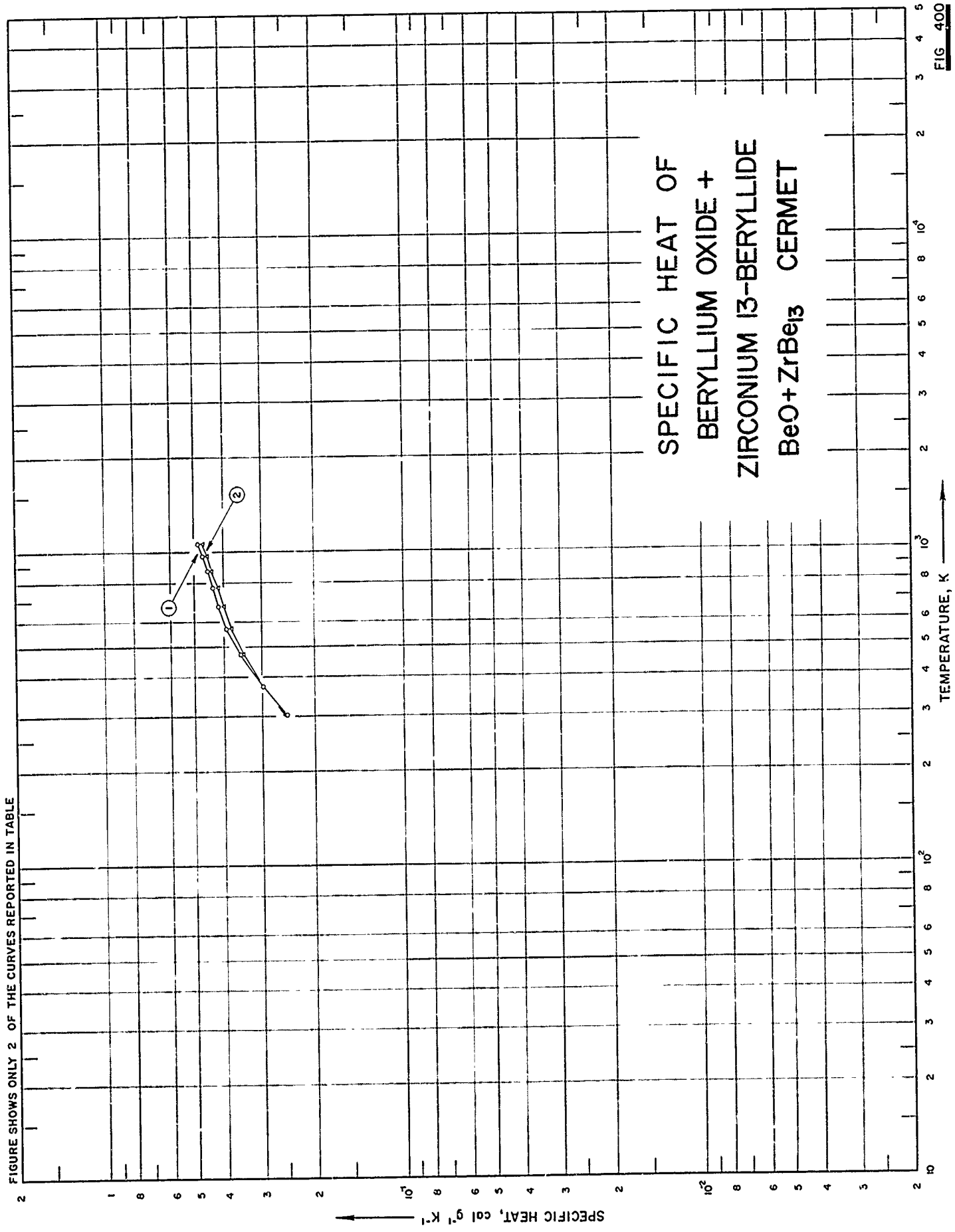

FIG. 400

SPECIFICATION TABLE NO. 400 SPECIFIC HEAT OF BERYLLIUM OXIDE + ZIRCONIUM 13-BERYLLIDE, BeO + ZrBe₁₃ CERMET
 [For Data Reported in Figure and Table No. 400]

Curve No.	Ref. No.	Year	Temp. Range, K	Reported Error, %	Name and Specimen Designation	Composition (weight percent), Specifications and Remarks
1	45	1962	303-1073	< 3.0		Nominal composition: 94 BeO and 6 ZrBe ₁₃ .
2	45	1962	303-1073	< 3.0		Nominal composition: 91 BeO and 9 ZrBe ₁₃ .
3	45	1962	303-1073	< 3.0		Nominal composition: 82 BeO and 18 ZrBe ₁₃ .

DATA TABLE NO. 400 SPECIFIC HEAT OF BERYLLIUM OXIDE + ZIRCONIUM 13-BERYLLIDE, BeO + ZrBe₁₃ CERMET
 [Temperature, T, K; Specific Heat, C_p, Cal g⁻¹ K⁻¹]

T	C _p
<u>CURVE 1</u>	
	2.49 x 10 ⁻¹
303	3.00
373	3.54
473	3.95
573	4.19
673	4.36
773	4.54
873	4.71
973	4.89
1073	
<u>CURVE 2*</u>	
	2.50 x 10 ⁻¹
303	3.00
373	3.57
473	3.94
573	4.17
673	4.35
773	4.52
873	4.69
973	4.86
1073	
<u>CURVE 3</u>	
	2.53 x 10 ⁻¹
303	3.00*
373	3.51
473	3.81
573	4.03
673	4.23
773	4.40
873	4.56
973	4.73
1073	

* Not shown on plot

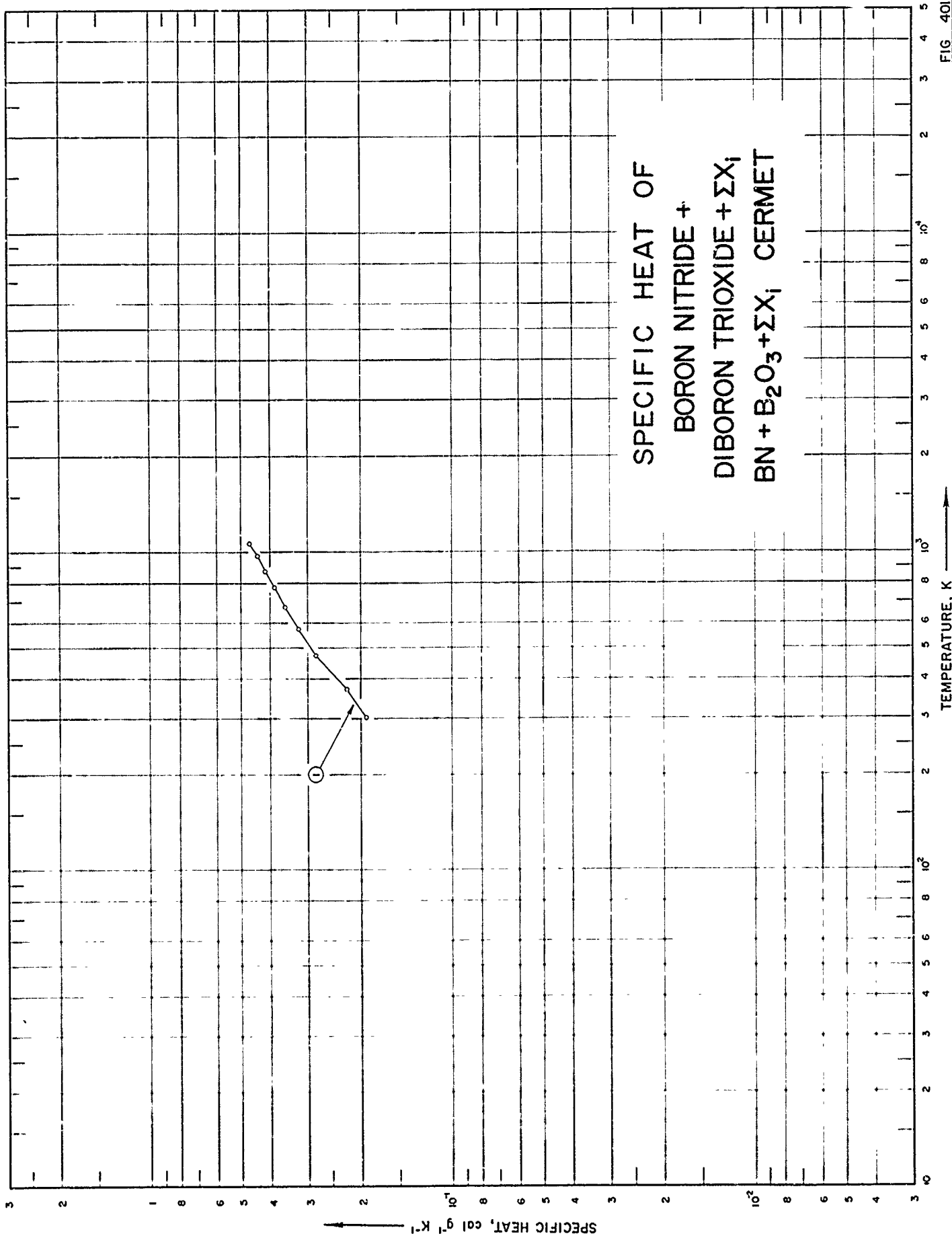

FIG 401

SPECIFICATION TABLE NO. 401 SPECIFIC HEAT OF BORON NITRIDE + DIBORON TRIOXIDE + Σ Xi, BN + B₂O₃ + Σ Xi CERMET

[For Data Reported in Figure and Table No. 401]

Curve No.	Ref. No.	Year	Temp. Range, K	Reported Error, %	Name and Specimen Designation	Composition (weight percent), Specifications and Remarks
1	45	1962	303-1073	< 3.0		97.4 BN, 2.4 B ₂ O ₃ , 0.2 Al and Si.

DATA TABLE NO. 401 SPECIFIC HEAT OF BORON NITRIDE + DIBORON TRIOXIDE + $\sum X_i$, BN + B₂O₃ + $\sum X_i$ CERMIET
 [Temperature, T, K; Specific Heat, C_p, Cal g⁻¹ K⁻¹]

T	C _p
CURVE 1	
303	1.93 x 10 ⁻¹
373	2.36
473	2.83
573	3.24
673	3.58
773	3.89
873	4.16
973	4.41
1073	4.68

SPECIFIC HEAT OF
BORON NITRIDE + CARBON
BN + C CERMET

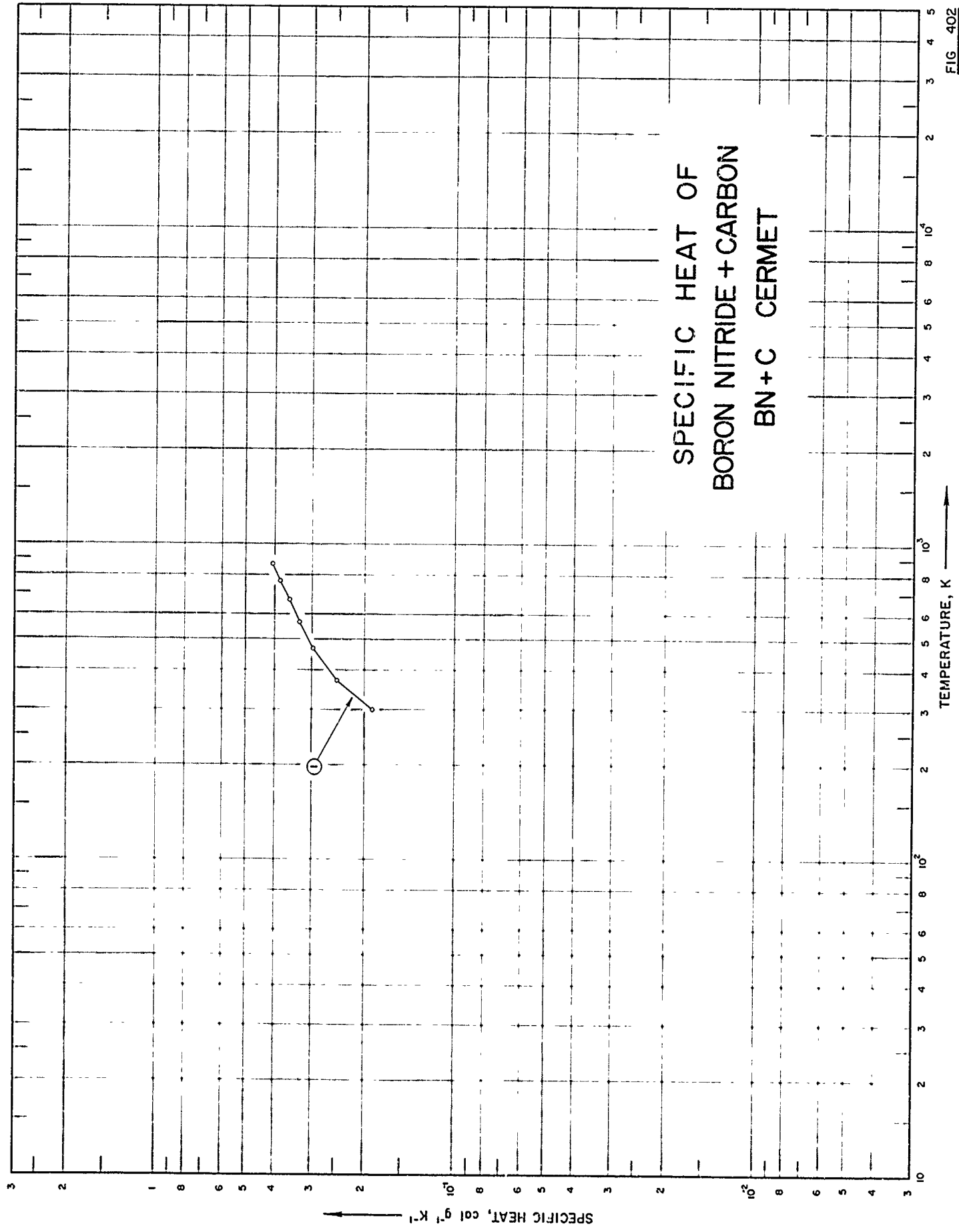

SPECIFICATION TABLE NO. 402 SPECIFIC HEAT OF BORON NITRIDE + CARBON. BN + C CERMET

[For Data Reported in Figure and Table No. 402]

Curve No.	Ref. No.	Year	Temp. Range, K	Reported Error, %	Name and Specimen Designation	Composition (weight percent), Specifications and Remarks
1	45	1962	303-873	< 3.0		Nominal composition: 80 BN and 20 C.

DATA TABLE NO. 402 SPECIFIC HEAT OF BORON NITRIDE + CARBON, BN + C CERMET
[Temperature, T, K; Specific Heat C_p , Cal g⁻¹ K⁻¹]

T	C_p
<u>CURVE 1</u>	
303	1.90 x 10 ⁻¹
373	2.50
473	3.00
573	3.36
673	3.62
773	3.87
873	4.11

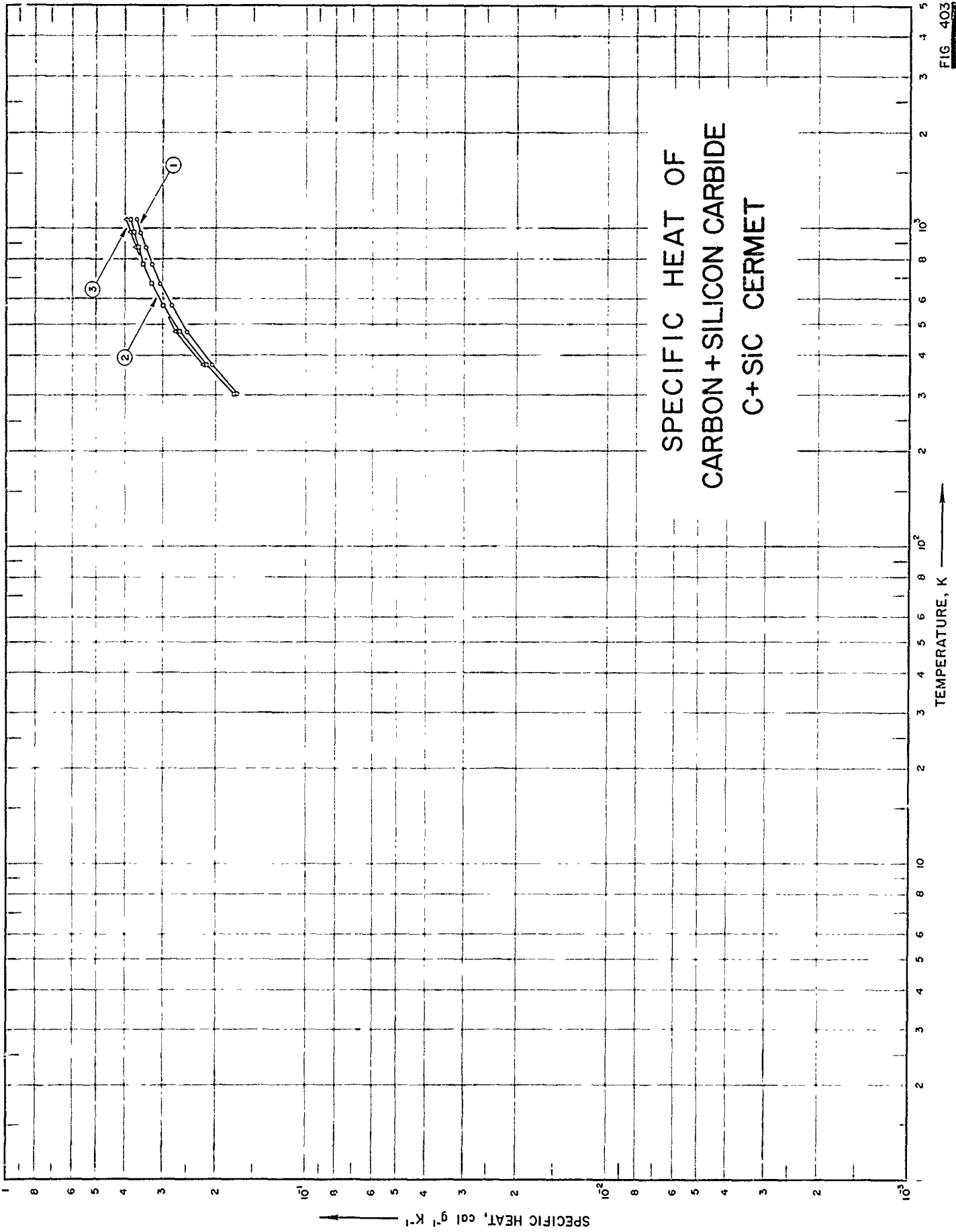

FIG 403

SPECIFICATION TABLE NO. 403 SPECIFIC HEAT OF CARBON + SILICON CARBIDE. C + SIC CERMET
 [For Data Reported in Figure and Table No. 403]

Curve No.	Ref. No.	Year	Temp. Range, K	Reported Error, %	Name and Specimen Designation	Composition (weight percent), Specifications and Remarks
1	45	1962	303-1073	< 3.0		Nominal composition: 57 C and 43 SIC.
2	45	1962	303-1073	< 3.0		Nominal composition: 72 C and 28 SIC.
3	45	1962	303-1073	< 3.0		Nominal composition: 77 C and 23 SIC.

DATA TABLE NO. 403 SPECIFIC HEAT OF CARBON + SILICON CARBIDE, C + SIC CERMET

[Temperature, T, K; Specific Heat, C_p , Cal $g^{-1} K^{-1}$]

T	C_p
<u>CURVE 1</u>	
303	1.70×10^{-1}
373	2.06
473	2.49
573	2.80
673	3.05
773	3.25
873	3.41
973	3.55
1073	3.65
<u>CURVE 2</u>	
303	1.73×10^{-1}
373	2.15
473	2.63
573	2.99
673	3.26
773	3.47
873	3.60
973	3.73
1073	3.83
<u>CURVE 3</u>	
303	1.73×10^{-1} *
373	2.30
473	2.74
573	3.04*
673	3.28*
773	3.49*
873	3.67
973	3.84
1073	3.98

* Not shown on plot

SPECIFIC HEAT OF
SILICON CARBIDE + CARBON + ΣX_i
SiC + C + ΣX_i CERMET

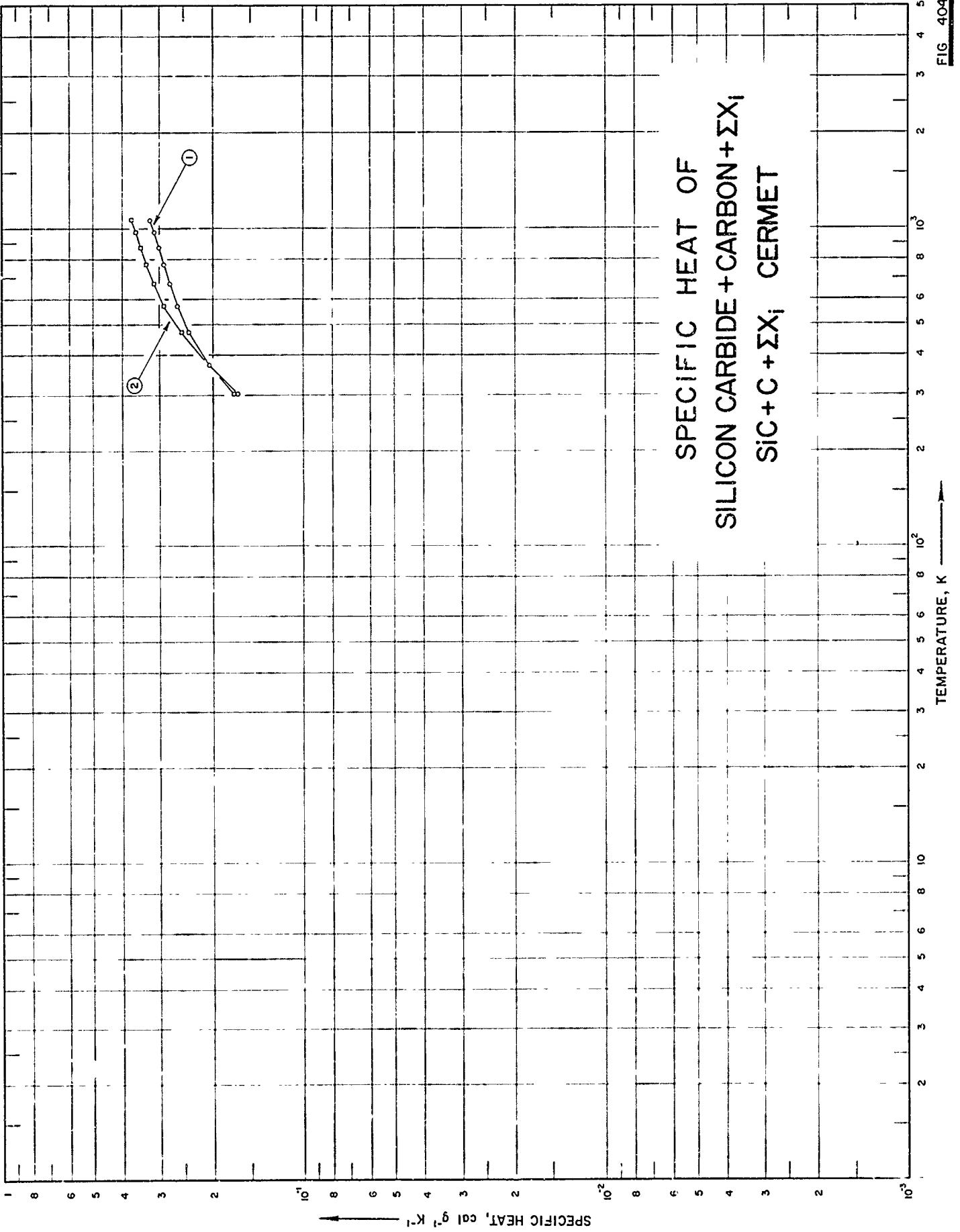

SPECIFICATION TABLE NO. 404 SPECIFIC HEAT OF SILICON CARBIDE + CARBON + ΣX_1 , SiC + C + ΣX_1 CERMET

[For Data Reported in Figure and Table No. 404]

Curve No.	Ref. No.	Year	Temp. Range, K	Reported Error, %	Name and Specimen Designation	Composition (weight percent), Specifications and Remarks
1	45	1962	303-1073	< 3.0	low free carbon	78.0 SiC, 20.0 C, 1.0 Si, and 1.0 various other metals.
2	45	1962	303-1073	< 3.0	high free carbon	50 SiC, 46 C, and 4 Si.

DATA TABLE NO. 404 SPECIFIC HEAT OF SILICON CARBIDE + CARBON + ΣX_i , SIC + C + ΣX_i CERMET
 [Temperature, T, K; Specific Heat, C_p , Cal g⁻¹ K⁻¹]

T	C_p
<u>CURVE 1</u>	
303	1.66×10^{-1}
373	2.07
473	2.41
573	2.63
673	2.78
773	2.92
873	3.03
973	3.14
1073	3.23
<u>CURVE 2</u>	
303	1.71×10^{-1}
373	2.07*
473	2.55
573	2.92
673	3.14
773	3.32
873	3.47
973	3.60
1073	3.73

* Not shown on plot

FIGURE SHOWS ONLY 3 OF THE CURVES REPORTED IN TABLE

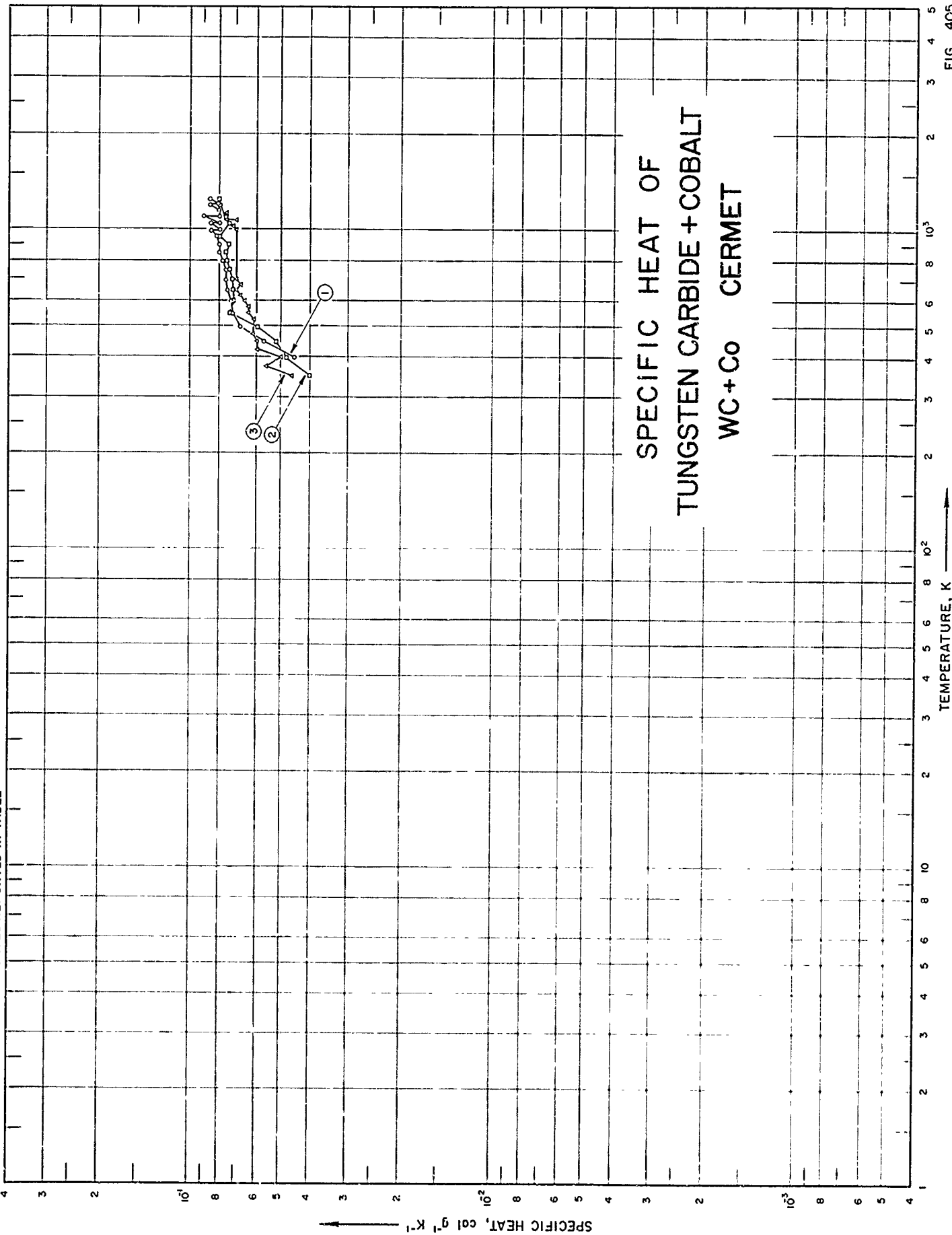

FIG. 405

SPECIFICATION TABLE NO. 405 SPECIFIC HEAT OF TUNGSTEN CARBIDE + COBALT, WC + Co CERMET

[For Data Reported in Figure and Table No. 405]

Curve No.	Ref. No.	Year	Temp. Range, K	Reported Error, %	Name and Specimen Designation	Composition (weight percent), Specifications and Remarks
1	351	1959	398-1249	5.0-15.0		7.0 Co; sintered at 1300-1500 C.
2	351	1959	349-1247	5.0-15.0		12.0 Co; sintered at 1300-1500 C.
3	351	1959	348-1260	5.0-15.0		5.0 Co; sintered at 1300-1500 C.
4	351	1959	349-1246	5.0-15.0		3.0 Co; sintered at 1300-1500 C.

DATA TABLE NO. 405 SPECIFIC HEAT OF TUNGSTEN CARBIDE + COBALT, WC + Co CERMET

[Temperature, T, K; Specific Heat, C_p , Cal $g^{-1} K^{-1}$]

T	C_p	T	C_p	T	C_p
<u>CURVE 1</u>					
398	4.51×10^{-2}	347.5	4.60×10^{-2}	846	6.99×10^{-2}
446	5.71	373	5.62	876	7.58
497	6.82	376	4.99	946	7.39
549	7.23	422	5.98	996	7.40
596	7.32	446	5.98	1046	7.59
647	7.52	472	6.16	1096	7.99
696	7.63	497	6.00*	1127	7.39
749	7.63	523	6.15	1196	7.58
797	7.84	546	6.41	1246	7.59
847	8.00	572	6.41		
897	8.01	597	6.60		
947	8.03*	622	6.81		
951	8.21	647	7.01		
996	8.52	672	6.81		
999	7.99	697	7.01		
1047	8.53	722	7.01*		
1050	7.99	749	7.01*		
1101	9.01	774	7.01*		
1101	8.60	797	7.01*		
1150	8.01	823	7.01*		
1197	8.62	849	7.01*		
1200	8.13	873	7.01*		
1249	8.63	896	7.01*		
		923	7.01*		
		946	7.01*		
		996	7.01		
		1022	7.20		
		1072	7.01		
		1073	7.61		
		1097	7.60*		
		1123	7.60		
		1200	8.02*		
		<u>CURVE 2</u>			
348.9	4.00×10^{-2}				
396	4.81				
446	5.20				
496	5.99				
547	7.39				
597	7.19				
647	7.21				
697	7.21				
747	7.43				
798	7.59				
846	7.62				
895	7.46				
946	8.02				
995	8.01*				
1045	7.45				
1097	7.63*				
1147	8.02*				
1196	8.02				
1247	8.02				
		<u>CURVE 3</u>			
		347.5	4.60×10^{-2}		
		373	5.62		
		376	4.99		
		422	5.98		
		446	5.98		
		472	6.16		
		497	6.00*		
		523	6.15		
		546	6.41		
		572	6.41		
		597	6.60		
		622	6.81		
		647	7.01		
		672	6.81		
		697	7.01		
		722	7.01*		
		749	7.01*		
		774	7.01*		
		797	7.01*		
		823	7.01*		
		849	7.01*		
		873	7.01*		
		896	7.01*		
		923	7.01*		
		946	7.01*		
		996	7.01		
		1022	7.20		
		1072	7.01		
		1073	7.61		
		1097	7.60*		
		1123	7.60		
		1200	8.02*		
		<u>CURVE 4</u>			
		349	4.60×10^{-2}		
		396	5.38		
		447	5.96		
		496	5.98		
		546	5.98		
		595	6.99		
		649	6.99		
		696	6.99		
		747	6.99		
		797	6.99		

* Not shown on plot

FIG. 406

SPECIFIC HEAT OF
ZIRCONIUM DIOXIDE + TITANIUM
ZrO₂+Ti CERMET

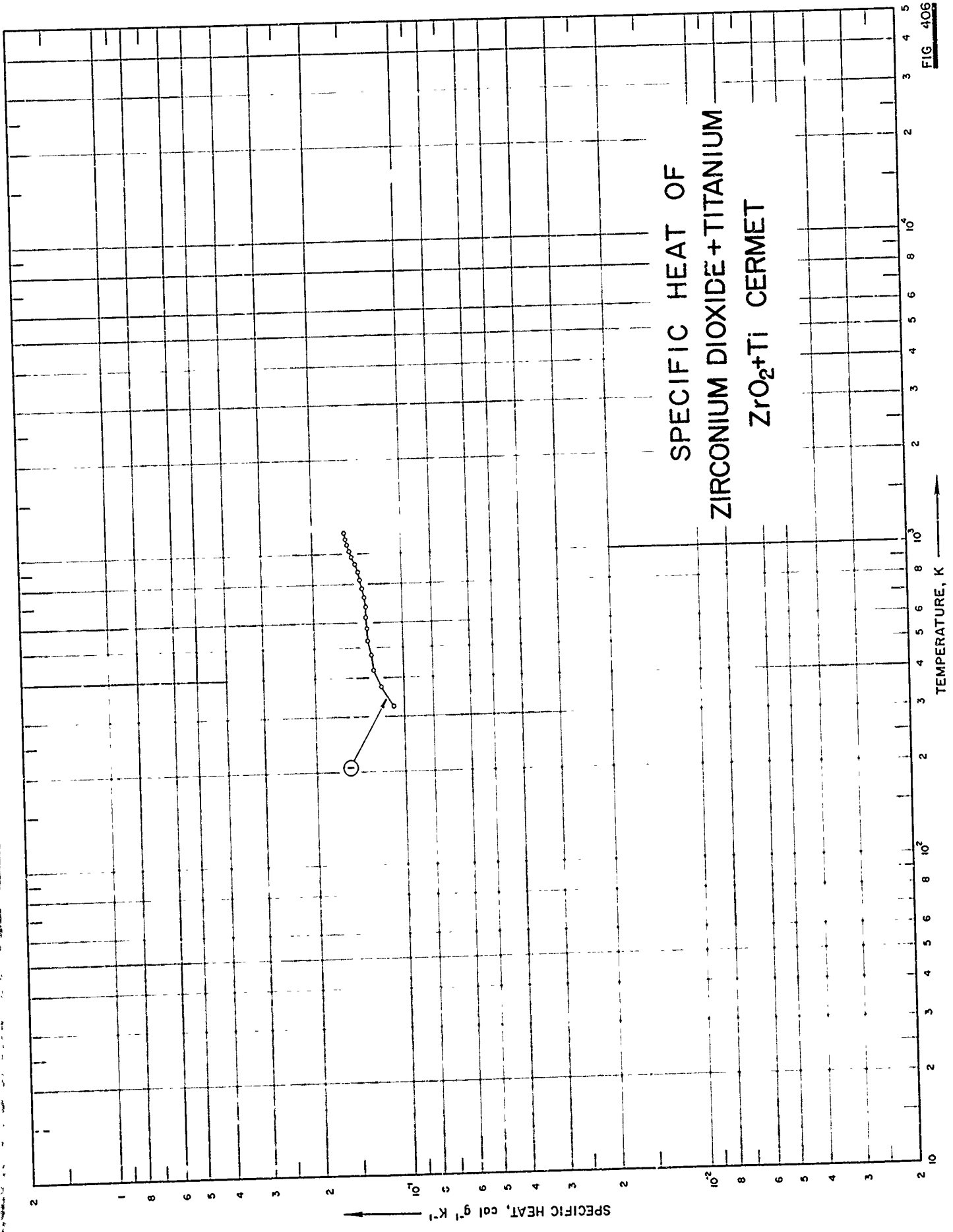

SPECIFICATION TABLE NO. 406 SPECIFIC HEAT OF ZIRCONIUM DIOXIDE + TITANIUM, ZrO₂ + Ti CERMET

[For Data Reported in Figure and Table No. 406]

Curve No.	Ref. No.	Year	Temp. Range, K	Reported Error, %	Name and Specimen Designation	Composition (weight percent), Specifications and Remarks
1	352	1964	323-1173	5.0	Milled Zirconia 15 mole % Ti (ZT-15-M)	93.68 ZrO ₂ and 6.32 Ti.

DATA TABLE NO. 406 SPECIFIC HEAT OF ZIRCONIUM DIOXIDE + TITANIUM. ZrO₂ + Ti CERMET
 Temperature. T. K. Specific Heat, C_p, Cal g⁻¹ K⁻¹

T	C _p
<u>CURVE 1</u>	
1.10 × 10 ¹	
323	1.21
373	1.28
423	1.30
473	1.31
523	1.31
573	1.34
623	1.35
673	1.35
723	1.37
773	1.38
823	1.40
873	1.42
923	1.45
973	1.49
1023	1.52
1073	1.54
1123	1.56
1173	1.57

FIGURE SHOWS ONLY 5 OF THE CURVES REPORTED IN TABLE

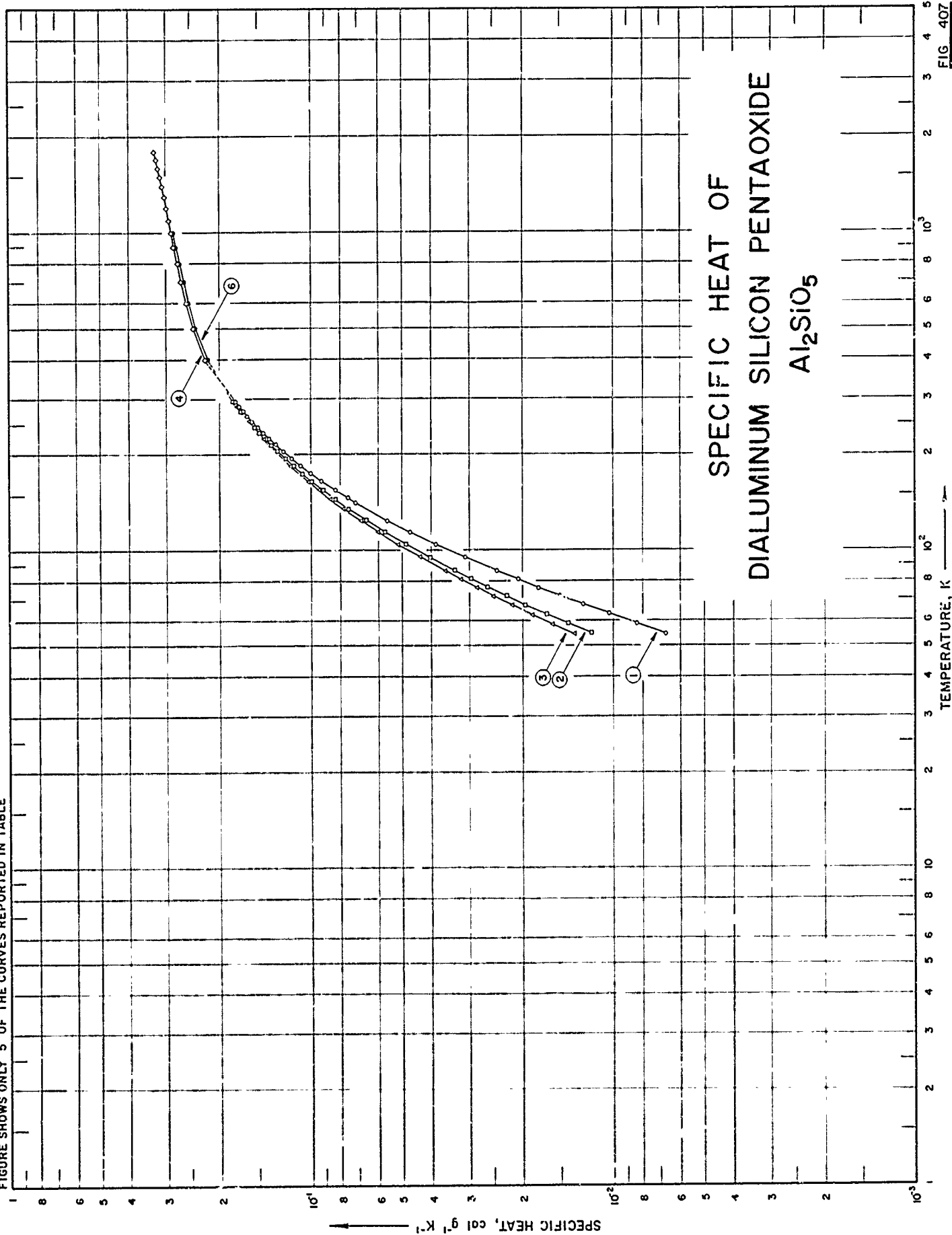

FIG. 407

PRECEDING PAGE BLANK-NOT FILMED

SPECIFICATION TABLE NO. 407 SPECIFIC HEAT OF DIALUMINUM SILICON PENTAOXIDE Al_2SiO_5

[For Data Reported in Figure and Table No. 407]

Curve No	Ref. No.	Year	Temp. Range, K	Reported Error, %	Name and Specimen Designation	Composition (weight percent). Specifications and Remarks
1	353	1950	55-296		Kyanite	62.2 Al_2O_3 , 36.9 SiO_2 , 0.1 Fe_2O_3 , 0.05 CaO .
2	353	1950	55-296		Andalusite	63.15 Al_2O_3 , 36.84 SiO_2 , 0.11 Fe_2O_3 , 0.02 CaO , < 0.01 TiO_2 , 0.01 MgO , 0.01 MnO .
3	353	1950	54-297		Sillimanite	61.8 Al_2O_3 , 36.44 SiO_2 , 0.98 Fe_2O_3 , 0.28 P_2O_5 , 0.24 MgO , 0.14 FeO , 0.07 CaO , 0.04 MnO , 0.04 F, < N_2O .
4	354	1964	400-1800		Kyanite	63.20 Al_2O_3 , 36.90 SiO_2 , 0.10 Fe_2O_3 , 0.05 CaO ; sample from Burnsville, N. Carolina.
5	354	1964	400-1800		Andalusite	63.15 Al_2O_3 , 36.84 SiO_2 , 0.11 Fe_2O_3 , 0.02 CaO , 0.01 MgO , 0.01 MnO , 0.01 TiO_2 ; contained a few muscovite [$\text{KAl}_3\text{Si}_3\text{O}_{10}(\text{OH})_2$] inclusions; sample from Standish, Maine.
6	354	1964	400-1800	0.1	Sillimanite	61.8 Al_2O_3 , 36.44 SiO_2 , 0.98 Fe_2O_3 , 0.28 P_2O_5 , 0.24 MgO , 0.14 FeO , 0.07 CaO , 0.04 F, 0.04 MnO , < 0.01 Na_2O , contained < 0.7 wagnerite ($\text{MgF} \cdot \text{MgPO}_4$) inclusions; sample from Benson Mines, New York.

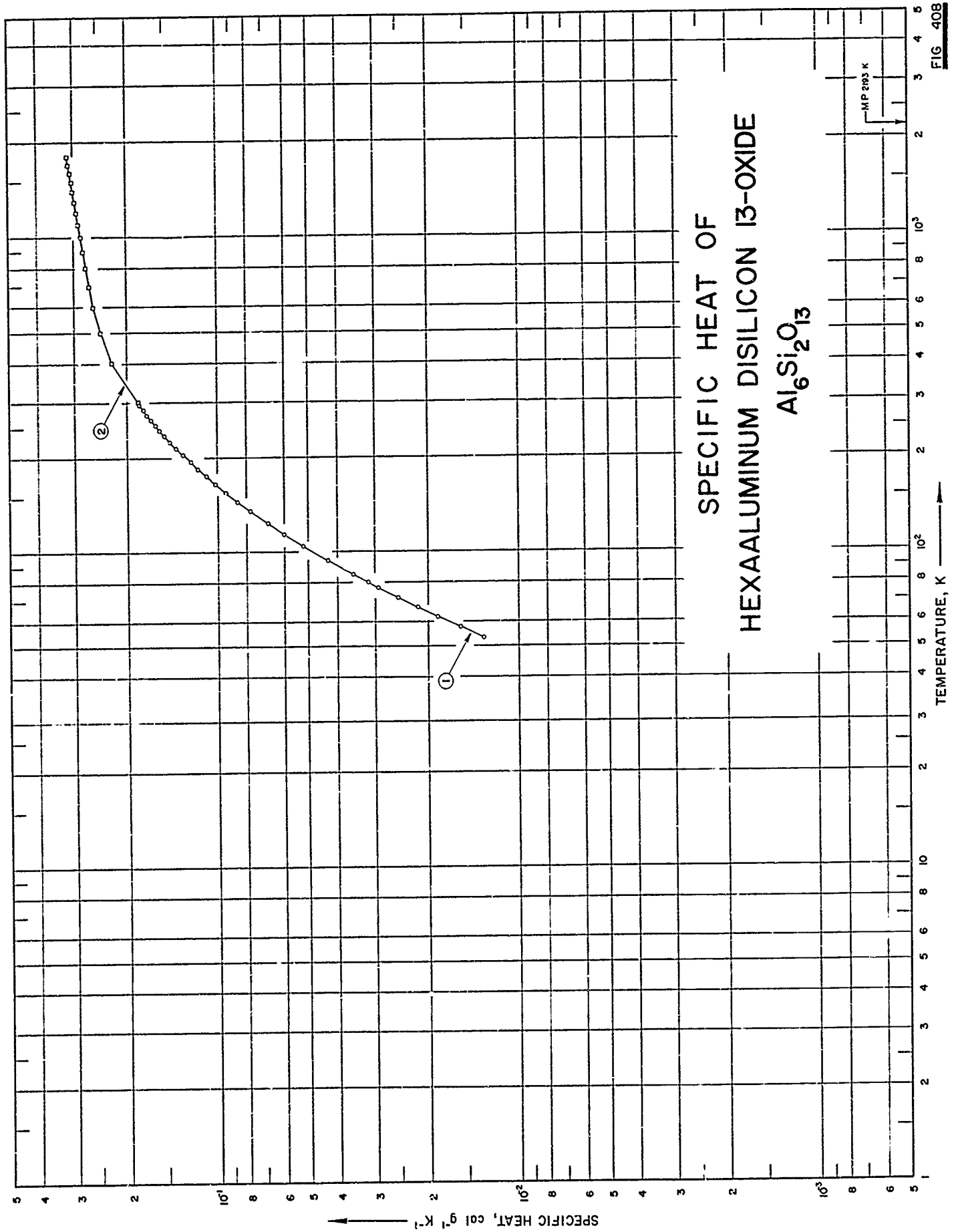

SPECIFICATION TABLE NO. 408 SPECIFIC HEAT OF HEXAALUMINUM DISILICON 13-OXIDE $Al_6Si_2O_{13}$

[For Data Reported in Figure and Table No. 408]

Curve No.	Ref. No.	Year	Temp. Range, K	Reported Error, %	Name and Specimen Designation	Composition (weight percent), Specifications and Remarks
1	355	1963	5J-296	0.3	Mullite	71.69 Al_2O_3 , 28.22 SiO_2 ; prepared by heating stoichiometric mixture of Al_2O_3 and SiO_2 for 12 days at 1500-1540 C.
2	355	1963	298-1800	0.3	Mullite	Same as above.

DATA TABLE NO. 408 SPECIFIC HEAT OF HEXAALUMINUM DISILICON 13-OXIDE $\text{Al}_6\text{Si}_2\text{O}_{13}$ [Temperature, T, K; Specific Heat, C_p , Cal g⁻¹ K⁻¹]

T	C_p	
	CURVE 1	CURVE 2 (cont.)
53.48	1.31×10^{-2}	3.072×10^{-1}
57.77	1.57	3.106
62.14	1.87	3.140
66.74	2.17	
71.78	2.523	
76.88	2.927	
80.05	3.169	
84.84	3.556	
94.36	4.319	
105.04	5.201	
114.62	6.004	
124.53	6.844	
136.00	7.807	
145.96	8.614	
155.77	9.417	
165.95	1.021×10^{-1}	
175.92	1.097	
186.18	1.171	
195.79	1.239	
206.27	1.310	
216.16	1.377	
226.14	1.440	
236.09	1.502	
246.46	1.563	
256.56	1.619	
266.45	1.670	
276.34	1.723	
287.09	1.774	
296.35	1.823	
CURVE 2		
298.15	1.829×10^{-2}	
300	1.840	
400	2.249	
500	2.454	
600	2.580	
700	2.668	
800	2.736	
900	2.792	
1000	2.841	
1100	2.885	
1200	2.926	
1300	2.965	
1400	3.002	
1500	3.037	

* Not shown on plot

FIG. 409

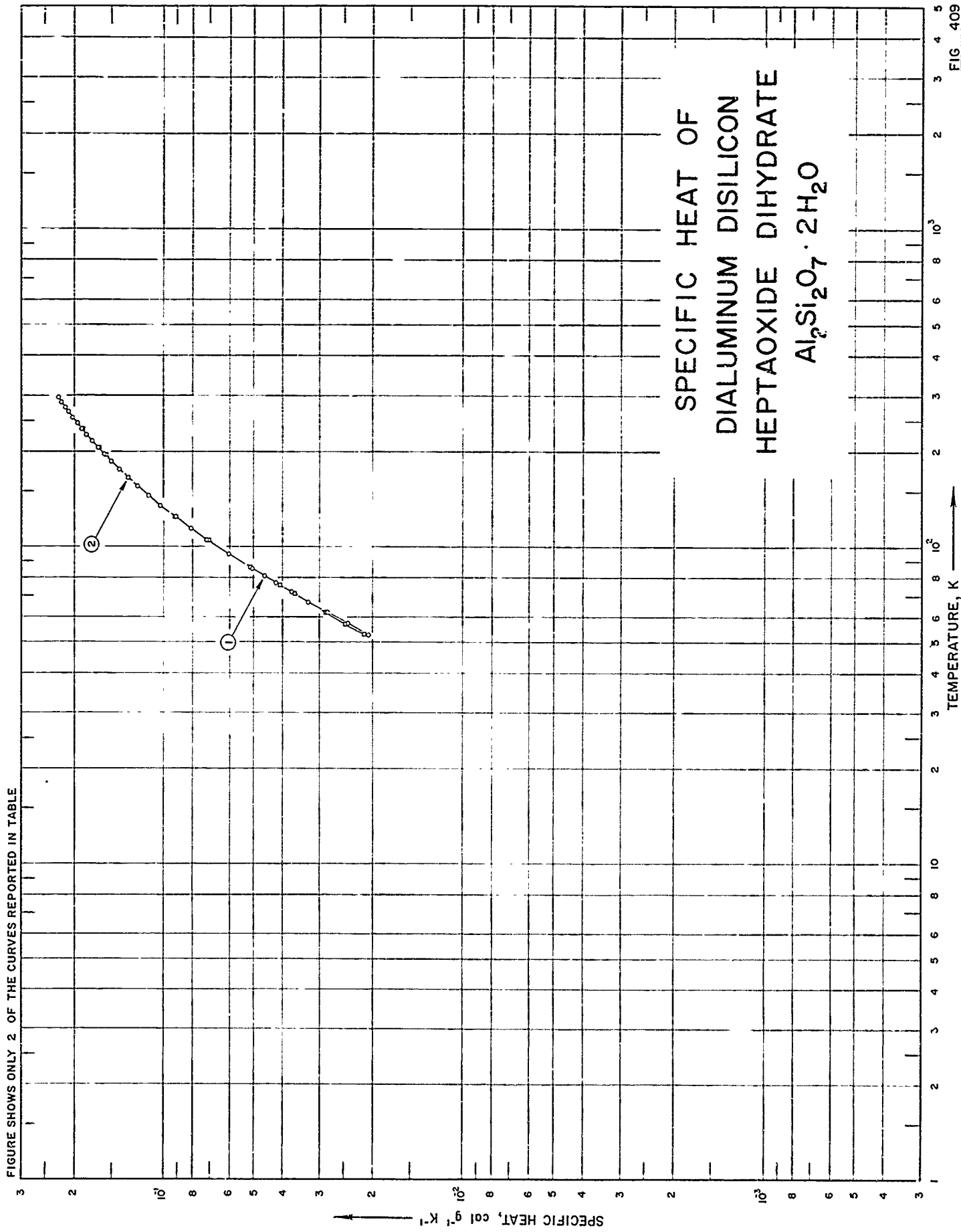

SPECIFICATION TABLE NO. 409 SPECIFIC HEAT OF DIALUMINUM DISILICON HEPTAOXIDE DIHYDRATE $\text{Al}_2\text{Si}_2\text{O}_7 \cdot 2\text{H}_2\text{O}$

[For Data Reported in Figure and Table No. 409]

Curve No.	Ref. No.	Year	Temp. Range, K	Reported Error, %	Name and Specimen Designation	Composition (weight percent), Specifications and Remarks
1	356	1961	53-296		Halloysite	45.98 SiO_2 , 40.12 Al_2O_3 , 13.95 H_2O , 0.20 Na_2O , 0.14 SO_3 , 0.03 CaO , 0.02 TiO_2 , 0.02 Na_2O , <0.01 Fe_2O_3 , nil K_2O , nil MgO ; heated to 230 C to remove excess water.
2	356	1961	53-296		Kaolinite	46.59 SiO_2 , 39.48 Al_2O_3 , 13.74 H_2O ; heated to 110 C to remove excess water.
3	356	1961	53-296		Dickite	45.21 SiO_2 , 39.92 Al_2O_3 , 13.92 H_2O , 0.35 Fe_2O_3 , 0.12 TiO_2 , 0.08 MgO , 0.04 K_2O and 0.01 CaO ; heated to 400 C to remove excess water.

DATA TABLE NO. 409 DIALUMINUM DISILICON HEPTAOXIDE DIHYDRATE $Al_2Si_2O_7 \cdot 2H_2O$ [Temperature, T, K; Specific Heat, C_p , Cal $g^{-1} K^{-1}$]

T	C_p	T	C_p
<u>CURVE 1</u>			
52.79	2.077×10^{-2}	156.96	1.236×10^{-1} *
57.33	2.437	166.43	1.322
62.03	2.847	176.38	1.413*
66.88	3.293	186.29	1.495*
71.75	3.754	196.26	1.576
76.72	4.230	206.29	1.655
80.80	4.636	216.55	1.738*
85.28	5.086	226.07	1.812*
89.90	5.573	236.05	1.878
105.62	7.181	245.85	1.947*
114.77	8.115	256.70	2.017*
124.79	9.141	266.14	2.086*
135.82	1.027×10^{-1}	276.44	2.145*
145.70	1.127	286.64	2.205*
155.94	1.227*	296.19	2.261*
165.99	1.322*		
176.20	1.414	<u>CURVE 3*</u>	
186.38	1.504	52.76	2.042×10^{-2}
196.07	1.582	57.14	2.375
206.53	1.671	61.55	2.741
216.29	1.748	66.08	3.135
226.31	1.822	70.86	3.564
236.30	1.893	75.63	4.005
245.76	1.959	81.47	4.563
256.55	2.032	85.80	4.966
267.08	2.097	94.95	5.864
276.54	2.155	105.56	6.910
286.64	2.212	114.80	7.836
295.94	2.265	124.89	8.843
		136.06	9.947
		145.67	1.087×10^{-1}
		156.07	1.185
		166.10	1.277
		176.26	1.367
		186.10	1.450
		196.36	1.532
		206.16	1.614
		216.51	1.695
		226.32	1.767
		236.15	1.836
		246.20	1.906
		256.44	1.973
		267.78	2.037
		276.41	2.094
		286.64	2.153
		296.42	2.209
<u>CURVE 2</u>			
53.20	2.142×10^{-2}		
57.46	2.483		
62.05	2.874		
66.66	3.283*		
71.18	3.692		
75.73	4.121		
80.97	4.648*		
86.10	5.156		
94.99	6.077*		
104.99	7.127		
114.58	8.134*		
124.89	9.188		
135.90	1.031×10^{-1} *		
145.94	1.130*		

* Not shown on plot

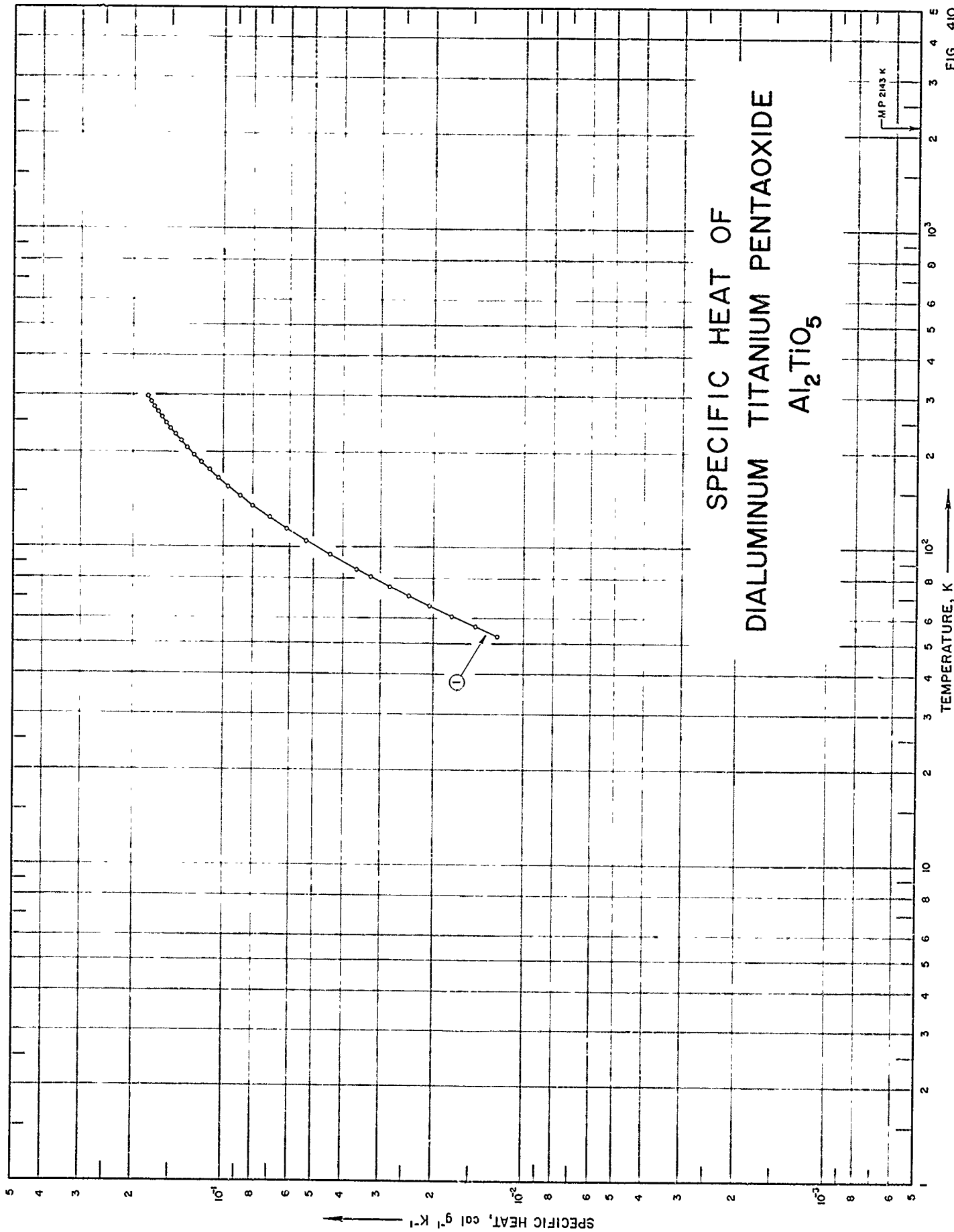

FIG 410

SPECIFICATION TABLE NO. 410 SPECIFIC HEAT OF DIALUMINUM TITANIUM PENTAOXIDE Al_2TiO_5

[For Data Reported in Figure and Table No. 410]

Curve No.	Ref. No.	Year	Temp. Range, K	Reported Error, %	Name and Specimen Designation	Composition (weight percent), Specifications and Remarks
1	358	1955	53-298			43.95 TiO (43.93 theo.), 0.06 SiO; prepared from pure hydrated alumina and pure titania; pressed into pellets and heated 5 times for 96 hrs between 1400 and 1500 C and 43 hrs between 1500 and 1570 C; quenched to room temperature.

DATA TABLE NO. 410 SPECIFIC HEAT OF DIALUMINUM TITANIUM PENTAOXIDE Al_2TlO_6
 [Temperature, T, K; Specific Heat, C_p , Cal $\text{g}^{-1} \text{K}^{-1}$]

T	C_p
	<u>CURVE 1</u>
52.74	1.226×10^{-2}
56.55	1.448
60.98	1.739
65.50	2.067
70.22	2.415
75.04	2.782
80.73	3.231
85.01	3.587
94.82	4.417
105.13	5.305
114.75	6.164
124.74	7.038
135.93	8.001
145.50	8.814
155.96	9.656
165.82	1.044×10^{-1}
175.83	1.119
185.70	1.192
195.95	1.261
206.12	1.325
216.20	1.390
226.10	1.449
236.04	1.505
245.67	1.555
256.22	1.608
266.21	1.657
276.27	1.704
286.46	1.748
296.39	1.785*
298.16	1.793

* Not shown on plot

FIG. 411

SPECIFIC HEAT OF
BARIUM SILICON TRIOXIDE
BaSiO₃

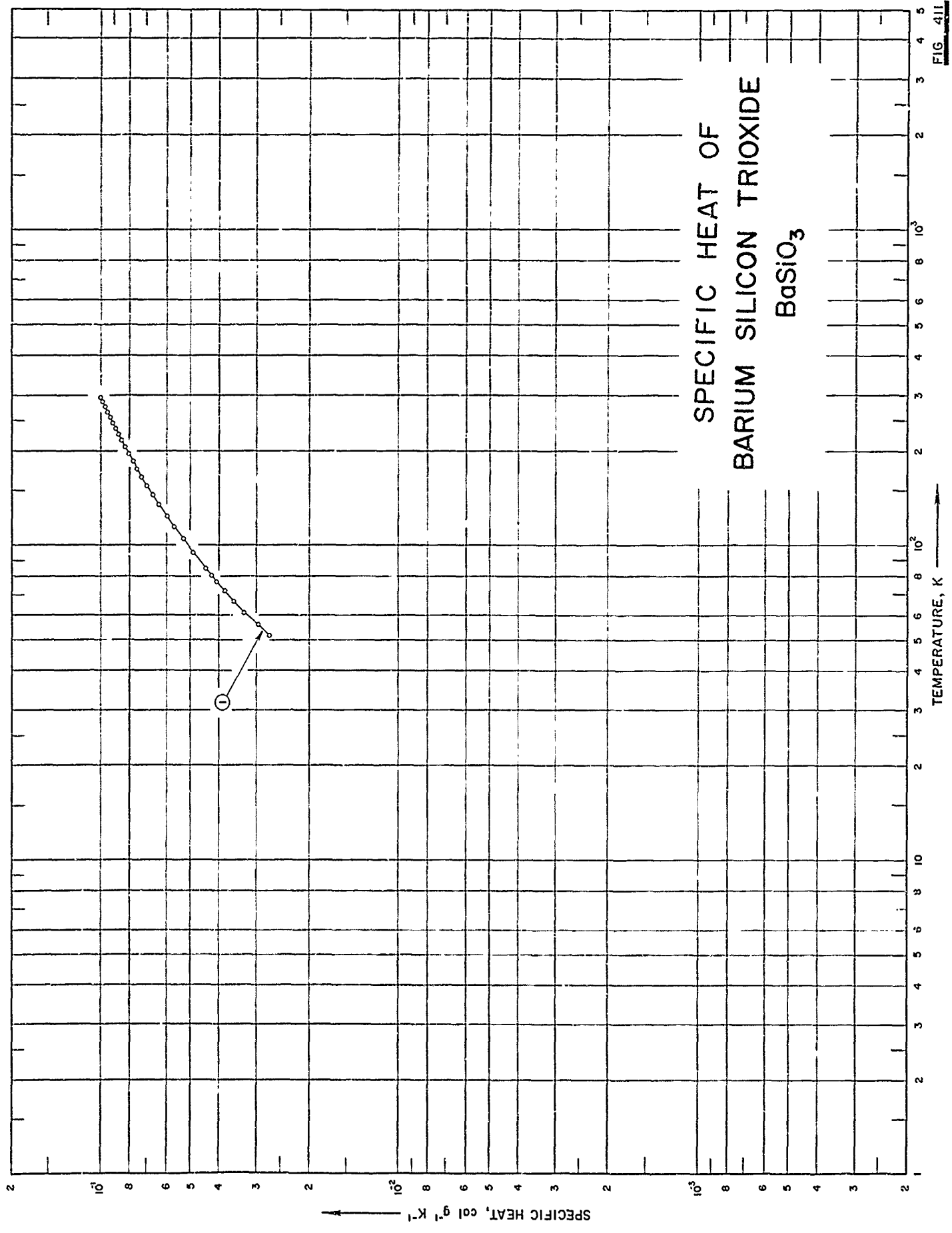

SPECIFICATION TABLE NO. 411 SPECIFIC HEAT OF BARIUM SILICON TRIOXIDE BaSiO₃

[For Data Reported in Figure and Table No. 411]

Curve No.	Ref. No.	Year	Temp. Range, K	Reported Error, %	Name and Specimen Designation	Composition (weight percent), Specifications and Remarks
1	360	1964	52-296			71.95 Ba, 28.17 SiO ₂ (71.85, 28.15 theo.); crystalline; prepared by prolonged heating of stoichiometric mixture of reagent-grade barium carbonate and pure quartz at 950-1350 C.

DATA TABLE NO. 411 SPECIFIC HEAT OF BARIUM SILICON TRIOXIDE BaSiO₃[Temperature, T, K; Specific Heat, C_p, Cal g⁻¹ K⁻¹]

T	C _p
51.99	2.733 x 10 ⁻²
56.14	2.978
61.22	3.302
66.76	3.594
71.80	3.852
76.60	4.095
80.08	4.259
84.52	4.456
95.26	4.915
105.61	5.328
114.49	5.670
124.62	6.030
135.66	6.401
145.61	6.729
155.79	7.028
165.84	7.310
175.99	7.591
185.94	7.839
196.01	8.073
206.16	8.317
216.15	8.532
226.21	8.753
235.98	8.959
245.85	9.151
256.33	9.343
266.62	9.540
276.46	9.699
287.21	9.896
296.17	1.005 x 10 ⁻¹

CURVE 1

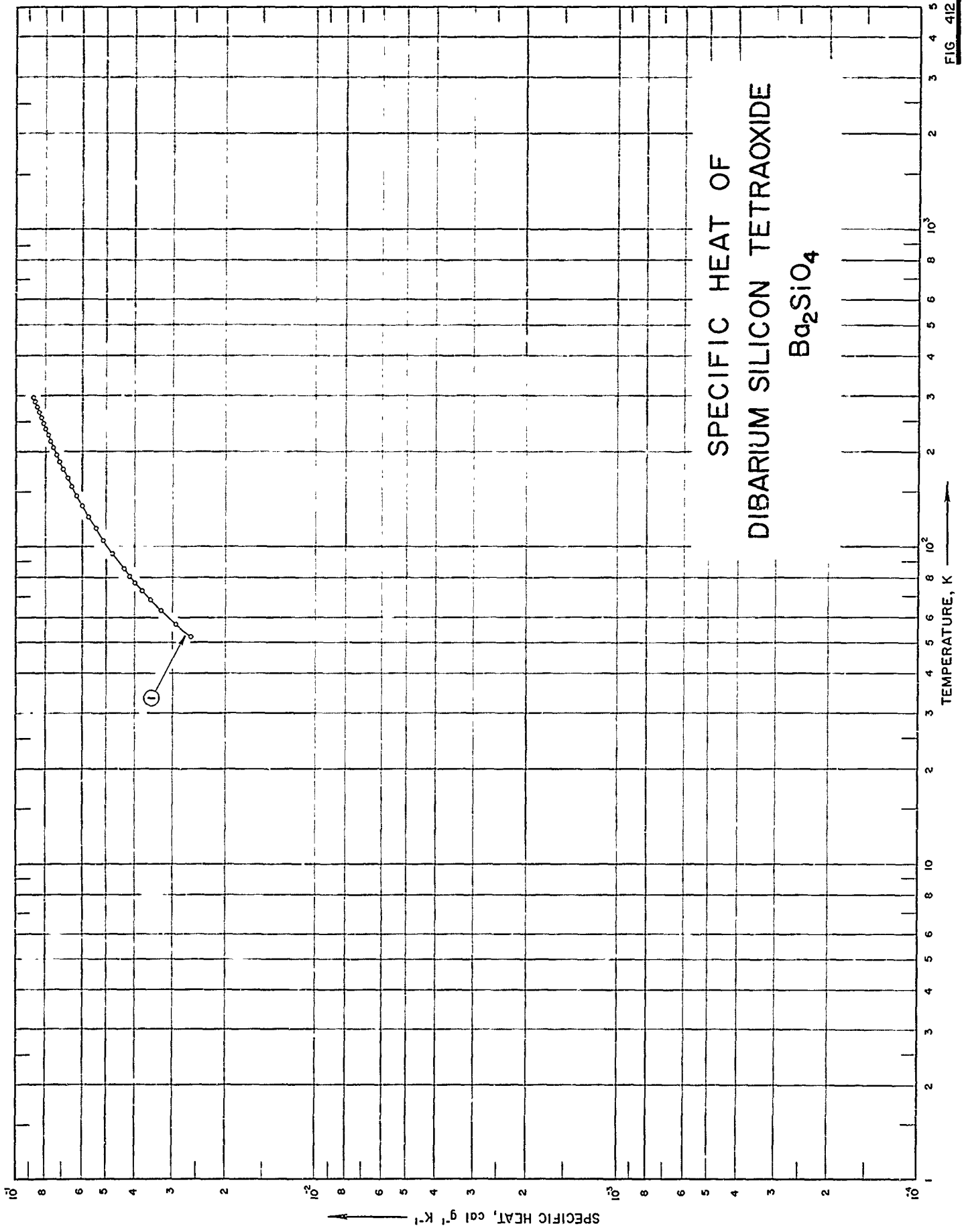

SPECIFICATION TABLE NO. 412 SPECIFIC HEAT OF DIBARIUM SILICON TETRAOXIDE Ba_2SiO_4

[For Data Reported in Figure and Table No. 412]

Curve No.	Ref. No.	Year	Temp. Range, K	Reported Error, %	Name and Specimen Designation	Composition (weight percent), Specifications and Remarks
1	360	1964	52-296			83.78 BaO, 16.39 SiO ₂ (83.62, 16.38 theo.).

DATA TABLE NO. 412 SPECIFIC HEAT OF DIBARIUM SILICON TETRAOXIDE Ba_2SiO_4 Temperature, T, K; Specific Heat, C_p , Cal g⁻¹ K⁻¹

T	C_p
52.15	2.613×10^{-2}
57.08	2.928
63.00	3.291
68.28	3.566
72.71	3.793
77.07	4.005
80.80	4.177
85.55	4.379
95.16	4.750
105.51	5.118
114.77	5.418
124.51	5.712
135.66	6.020
145.77	6.277
156.23	6.514
166.32	6.740
176.58	6.947
186.36	7.144
196.07	7.315
206.29	7.493
216.11	7.659
226.17	7.823
236.11	7.962
246.00	8.109
256.34	8.256
266.27	8.390
276.50	8.515
286.68	8.654
296.34	8.777

CURVE 1

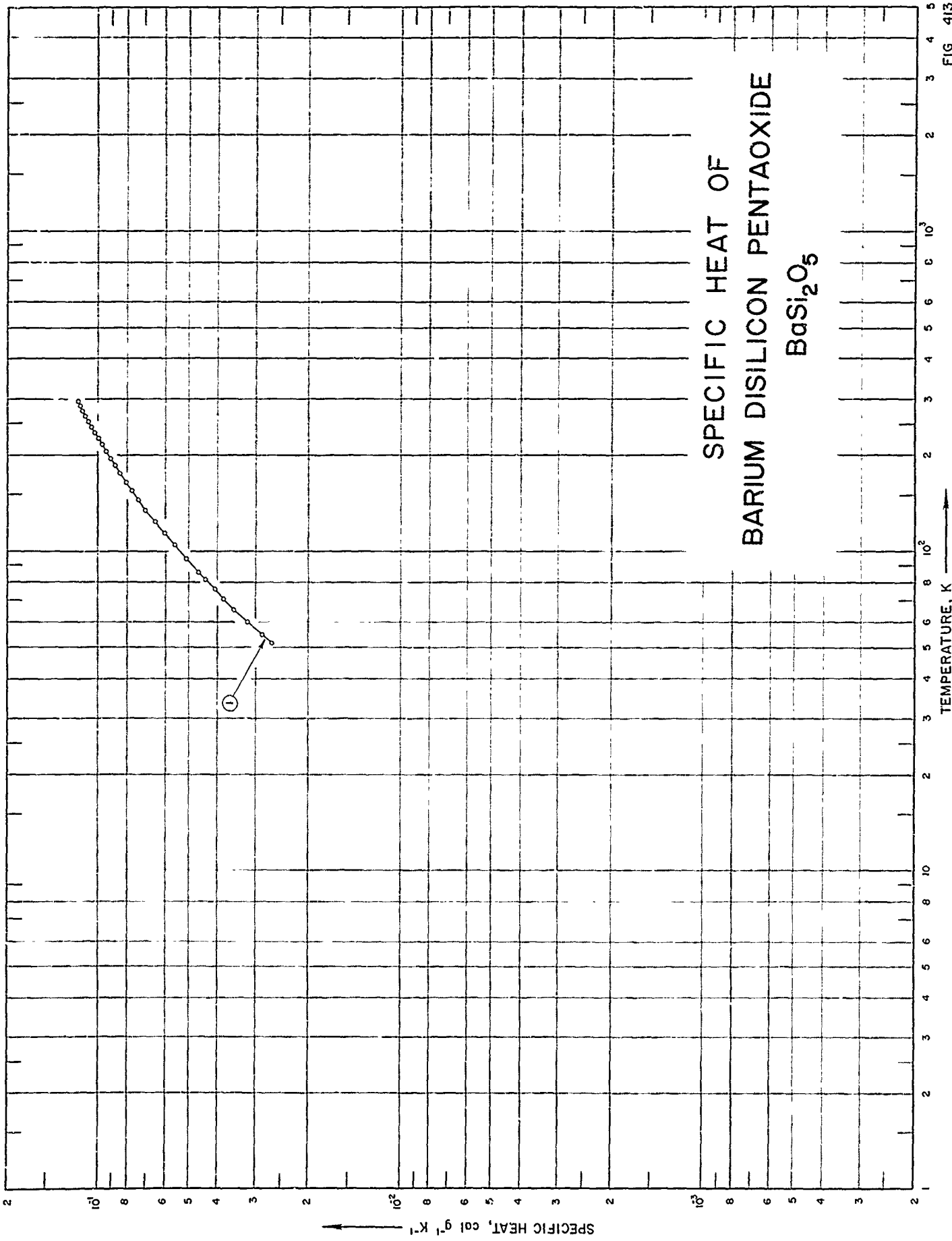

SPECIFICATION TABLE NO. 413 SPECIFIC HEAT OF BARIUM DISILICON PENTAOXIDE BaSi_2O_6

[For Data Reported in Figure and Table No. 413]

Curve No.	Ref. No.	Year	Temp. Range, K	Reported Error, %	Name and Specimen Designation	Composition (weight percent), Specifications and Remarks
1	360	1964	52-296			55.85 BaO, 43.77 SiO ₂ , 0.32 Al ₂ O ₃ (56.06, 43.94 theo.).

DATA TABLE NO. 413 SPECIFIC HEAT OF BARIUM DISILICON PENTAOXIDE BaSi_2O_5
 [Temperature, T, K; Specific Heat, C_p , Cal $\text{g}^{-1} \text{K}^{-1}$]

T	C_p
CURVE 1	
51.63	2.664×10^{-2}
54.92	2.867
60.07	3.195
65.86	3.544
71.17	3.843
76.42	4.131
81.81	4.417
86.41	4.658
94.76	5.071
105.28	5.587
114.77	6.029
124.83	6.479
135.83	6.958
145.71	7.353
155.78	7.725
165.89	8.098
177.05	8.486
185.88	8.771
195.99	9.093
206.03	9.400
216.26	9.703
226.04	9.970
236.16	1.025×10^{-1}
245.80	1.050
256.40	1.077
266.62	1.101
276.47	1.124
286.98	1.148
296.43	1.169

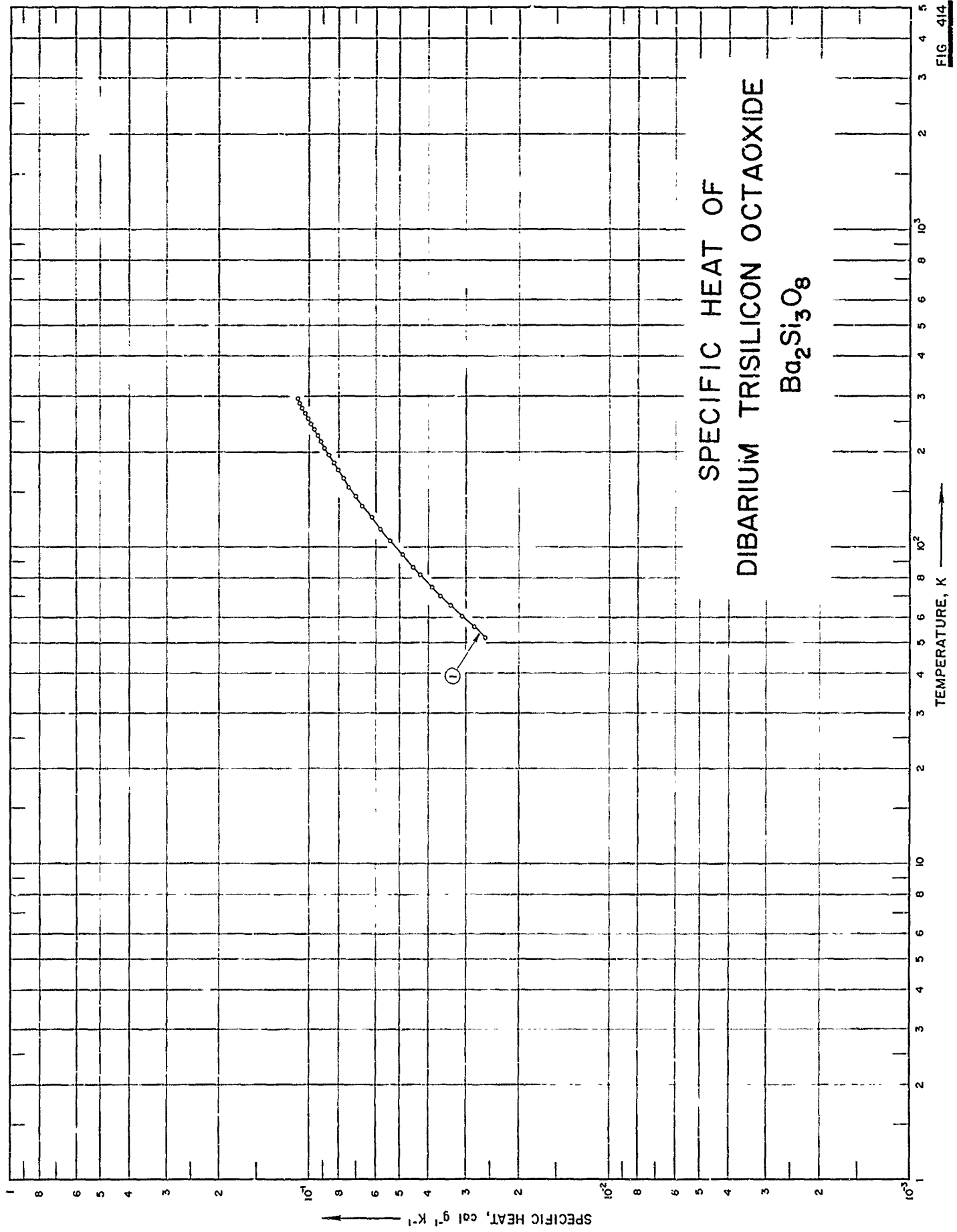

FIG. 414

SPECIFICATION TABLE NO. 414 SPECIFIC HEAT OF DIBARIUM TRISILICON OCTAOXIDE $Ba_2Si_3O_8$

[For Data Reported in Figure and Table No. 414]

Curve No.	Ref. No.	Year	Temp. Range, K	Reported Error, %	Name and Specimen Designation	Composition (weight percent), Specifications and Remarks
1	360	1964	52-296			63.00 BaO, 37.05 SiO ₂ , 0.01 Al ₂ O ₃ (62.98, 37.02 theo.).

DATA TABLE NO. 414 SPECIFIC HEAT OF DIBARIUM TRISILICON OCTAOXIDE $Ba_2Si_3O_8$ [Temperature, T, K; Specific Heat, C_p , Cal $g^{-1} K^{-1}$]

T	C_p
	<u>CURVE 1</u>
51.94	2.598×10^{-2}
55.94	2.828
60.53	3.130
65.56	3.389
70.13	3.656
74.67	3.908
81.65	4.284
86.42	4.518
94.73	4.908
105.09	5.387
114.76	5.816
124.66	6.227
135.86	6.672
145.69	7.032
155.85	7.391
165.84	7.722
175.92	8.044
185.90	8.348
196.01	8.636
206.29	8.921
216.40	9.196
226.11	9.431
236.16	9.637
245.77	9.811
256.45	1.015×10^{-1}
266.32	1.037
276.28	1.056
286.79	1.080
296.29	1.098

SPECIFIC HEAT OF BARIUM TITANIUM TRIOXIDE BaTiO₃

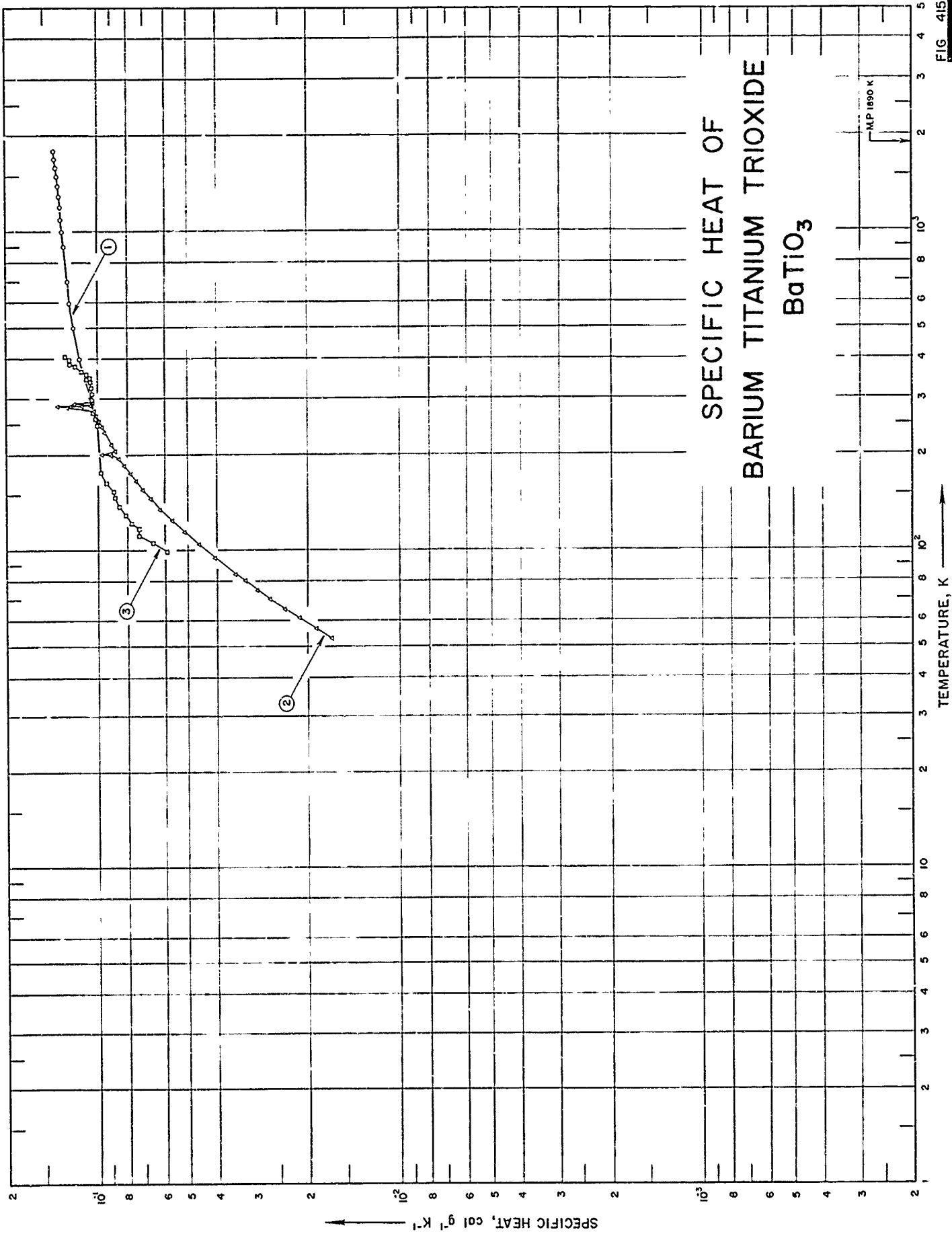

SPECIFICATION TABLE NO. 415 SPECIFIC HEAT OF BARIUM TITANIUM TRIOXIDE BaTiO_3

[For Data Reported in Figure and Table No. 415]

Curve No.	Ref. No.	Year	Temp. Range, K	Reported Error, %	Name and Specimen Designation	Composition (weight percent), Specifications and Remarks
1	361	1953	298-1800			99.7 BaTiO_3 .
2	362	1952	53-301	± 0.1		99.7 BaTiO_3 ; prepared from reagent grade barium hydroxide and titania (99.8 pure after ignition) by prolonged heating at 1350 C.
3	363	1952	99-407			Polycrystalline; sintered.

DATA TABLE NO. 415 SPECIFIC HEAT OF BARIUM TITANIUM TRIOXIDE BaTiO₃[Temperature, T, K; Specific Heat, C_p, Cal g⁻¹ K⁻¹]

T	C _p	T	C _p
<u>CURVE 1</u>			
298	1.65 x 10 ⁻¹	206.51	8.793 x 10 ⁻²
300	1.05*	268.71	8.801*
400	1.16	216.16	9.003
500	1.21	236.44	9.496
600	1.24	245.77	9.697
700	1.27	256.26	9.912
900	1.30	266.08	1.011 x 10 ⁻¹
1000	1.31	<u>CURVE 2</u>	
1100	1.32	99	5.89 x 10 ⁻²
1200	1.34	106	6.6
1300	1.35	112	7.3
1400	1.36	117	7.3
1500	1.37	121.5	7.74
1600	1.38	129	8.1
1700	1.39	137.5	8.5
1800	1.40	147	8.8
<u>CURVE 2</u>			
53.05	1.688 x 10 ⁻²	153.5	8.86
56.86	1.895	163.5	9.38
61.09	2.147	176	9.79
65.59	2.419	248	1.0 x 10 ⁻¹
70.23	2.691	261	1.0*
74.98	2.968	273	1.030
80.02	3.263	295	1.040*
84.34	3.516	302	1.05*
94.66	4.105	311	1.050
104.44	4.647	326.5	1.06
114.54	5.179	338	1.060
124.72	5.698	346	1.091
135.99	6.238	349	1.070
146.19	6.696	358	1.10
155.86	7.095	365	1.132
165.96	7.490	373	1.153*
175.97	7.850	380	1.20
186.23	8.210	387	1.245
186.89	8.227*	398	1.245
190.61	8.351*	406	1.265*
193.28	8.458*	407	1.286
195.32	8.544*		
195.83	8.548		
197.31	8.651*		
199.33	9.033		
201.70	9.740		
204.84	8.818*		

* Not shown on plot

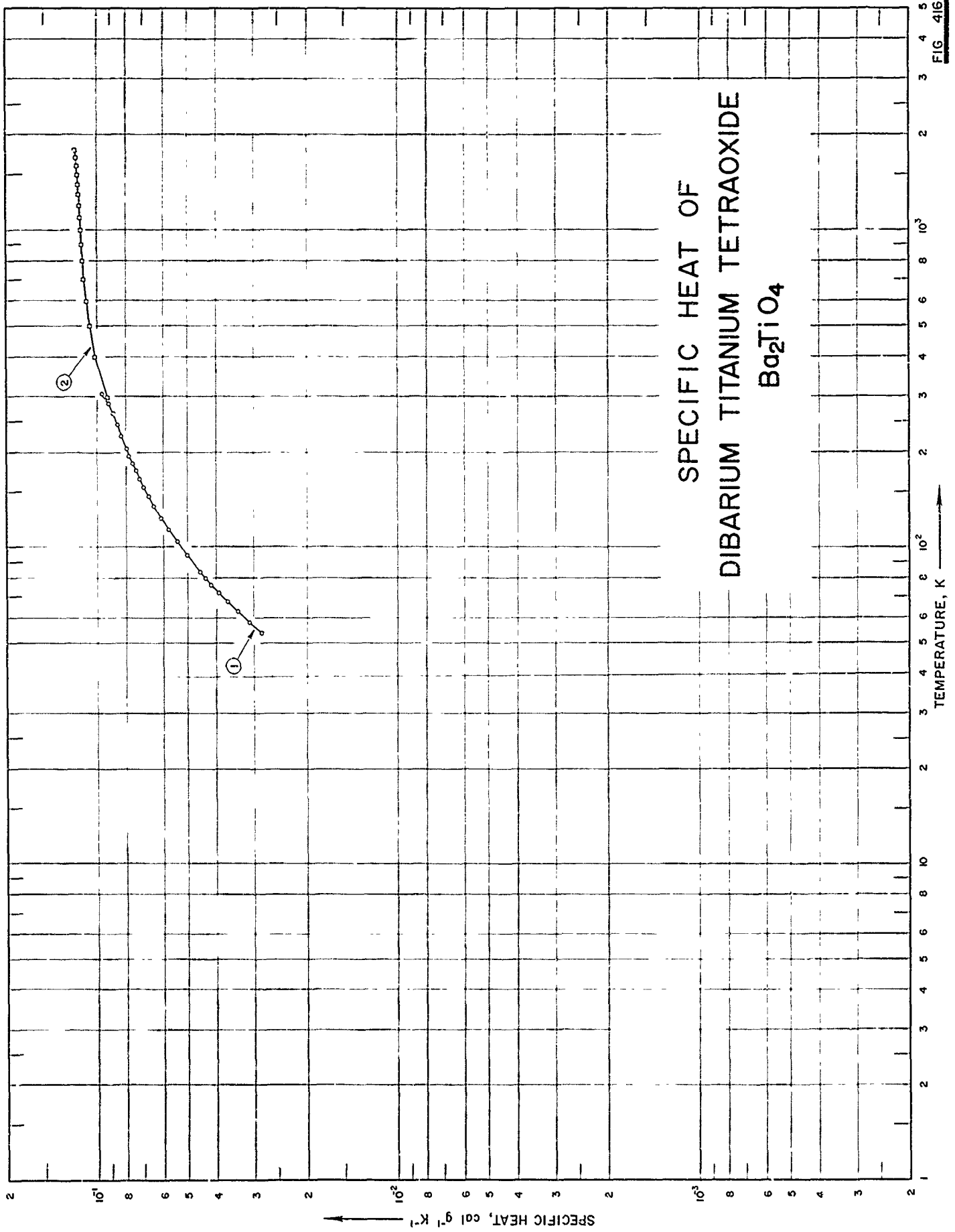

SPECIFICATION TABLE NO. 416 SPECIFIC HEAT OF DIBARIUM TITANIUM TETRAOXIDE Ba_2TiO_4

[For Data Reported in Figure and Table No. 416]

Curve No.	Ref. No.	Year	Temp. Range, K	Reported Error, %	Name and Specimen Designation	Composition (weight percent), Specifications and Remarks
1	363	1952	54-306			99.2 Ba_2TiO_4 ; 20.8 TiO_2 (20.67 theo.), 0.34 CaO, 0.02 SiO_2 ; no unreacted oxide or metatitanate.
2	361	1953	298-1800			99.2 Ba_2TiO_4 ; 20.8 TiO_2 (20.67 theo.), 0.34 CaO, 0.02 SiO_2 ; no unreacted oxide or metatitanate.

DATA TABLE NO. 416 SPECIFIC HEAT OF DIBARIUM TITANIUM TETRAOXIDE Ba₂TiO₄
 [Temperature, T, K; Specific Heat, C_p, Cal g⁻¹ K⁻¹]

T	C _p		T	C _p
	<u>CURVE 1</u>	<u>CURVE 2 (cont.)</u>		
54.00	2.848 x 10 ⁻²	1.14 x 10 ⁻¹	1100	1.14 x 10 ⁻¹
58.42	3.112	1.15	1200	1.15
63.14	3.414	1.16	1300	1.16
67.85	3.694	1.16	1400	1.16
72.35	3.934	1.17	1500	1.17
76.82	4.169	1.17	1600	1.17
80.14	4.340	1.18	1700	1.18
84.44	4.550	1.18	1800	1.18
94.90	5.013			
104.75	5.406			
114.70	5.783			
124.79	6.117			
136.05	6.464			
146.22	6.740			
156.08	6.981			
166.10	7.211			
176.19	7.431			
185.98	7.633			
196.00	7.809			
206.36	7.972			
216.50	8.155*			
226.39	8.305			
236.14	8.448*			
245.95	8.598			
256.26	8.717*			
267.53	8.869			
276.46	9.006*			
286.52	9.195			
296.44	9.203*			
298.69	9.407*			
298.42	9.224*			
302.62	9.508*			
306.70	9.622*			
298.16	9.436*			
<u>CURVE 2</u>				
298	9.22 x 10 ⁻²			
300	9.25*			
400	1.02 x 10 ⁻¹			
500	1.06			
600	1.09			
700	1.10			
800	1.12			
900	1.13			
1000	1.14			

* Not shown on plot

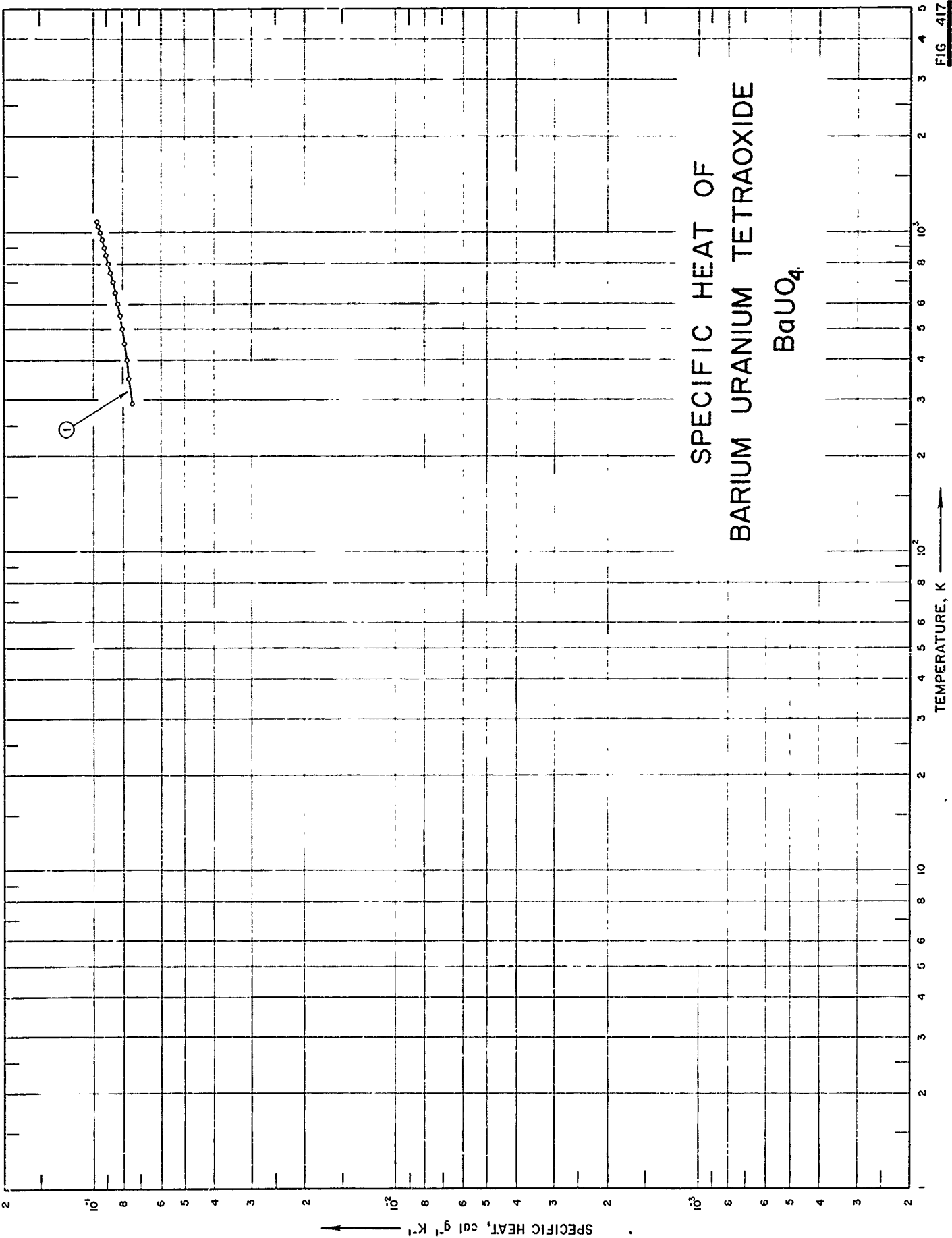

FIG. 417

SPECIFICATION TABLE NO. 417 SPECIFIC HEAT OF BARIUM URANIUM TETRAOXIDE BaUO₄

[For Data Reported in Figure and Table No. 417]

Curve No.	Ref. No.	Year	Temp. Range, K	Reported Error, %	Name and Specimen Designation	Composition (weight percent), Specifications and Remarks
1	362	1960	293-1084	0.1		53.95 U, 31.10 Ba.

DATA TABLE NO. 417 SPECIFIC HEAT OF BARIUM URANIUM TETRAOXIDE BaUO₄[Temperature, T, K; Specific Heat, C_p, Cal g⁻¹ K⁻¹]

T	C _p
<u>CURVE 1</u>	
293	7.46 x 10 ⁻²
300	7.48*
350	7.62
400	7.76
450	7.91
500	8.05
550	8.20
600	8.34
650	8.49
700	8.63
750	8.78
800	8.92
850	9.06
900	9.21
950	9.35
1000	9.50
1050	9.64
1084	9.74

* Not shown on plot

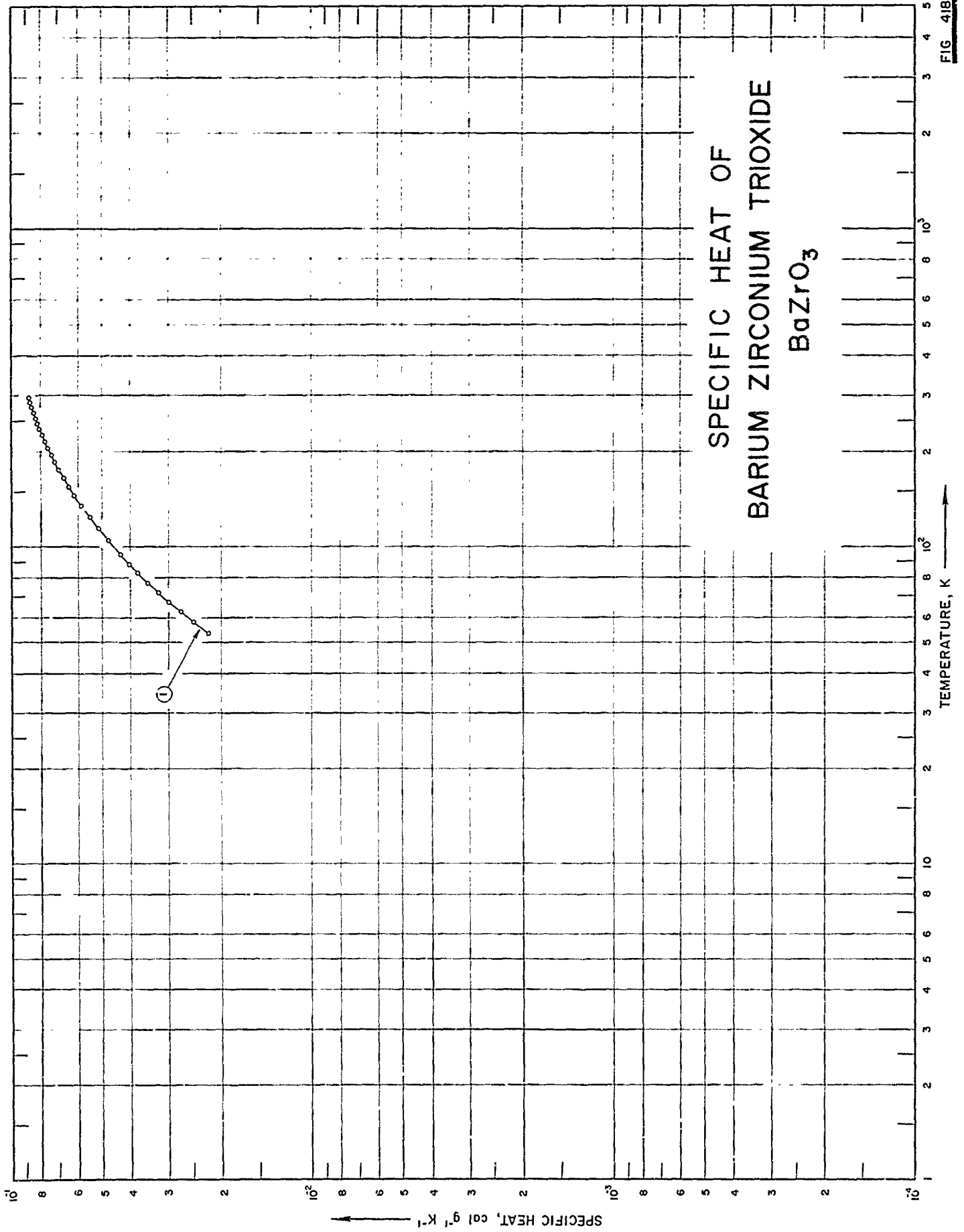

FIG. 41B

SPECIFICATION TABLE NO. 418 SPECIFIC HEAT OF BARIUM ZIRCONIUM TRIOXIDE BaZrO_3

[For Data Reported in Figure and Table No. 418]

Curve No.	Ref. No.	Year	Temp. Range, K	Reported Error, %	Name and Specimen Designation	Composition (weight percent), Specifications and Remarks
1	364	1960	53-296	0.3		55.40 BaO, 44.63 ZrO ₂ ; prepared by heating reagent-grade barium carbonate and pure zirconia for 24 hrs at 1000 C, 6 hrs at 1350-1400 C, 20 hrs at 1350-1470 C, and 12 hrs at 1300-1350 C.

DATA TABLE NO. 418 SPECIFIC HEAT OF BARIUM ZIRCONIUM TRIOXIDE BaZrO₃[Temperature, T, K; Specific Heat, C_p, Cal g⁻¹ K⁻¹]

T	C _p
CURVE 1	
53.62	2.236 x 10 ⁻²
58.29	2.499
62.70	2.748
67.31	3.003
72.16	3.262
77.30	3.521
83.43	3.822
88.45	4.060
94.97	4.350
105.20	4.783
114.81	5.156
124.56	5.499
136.14	5.890
145.96	6.201
155.99	6.479
165.80	6.729
176.74	6.982
186.00	7.191
196.12	7.394
206.34	7.593
216.04	7.755
226.22	7.933
236.11	8.077
245.55	8.215
256.53	8.348
266.48	8.468
276.36	8.576
286.50	8.674
296.08	8.771

FIG. 419-1

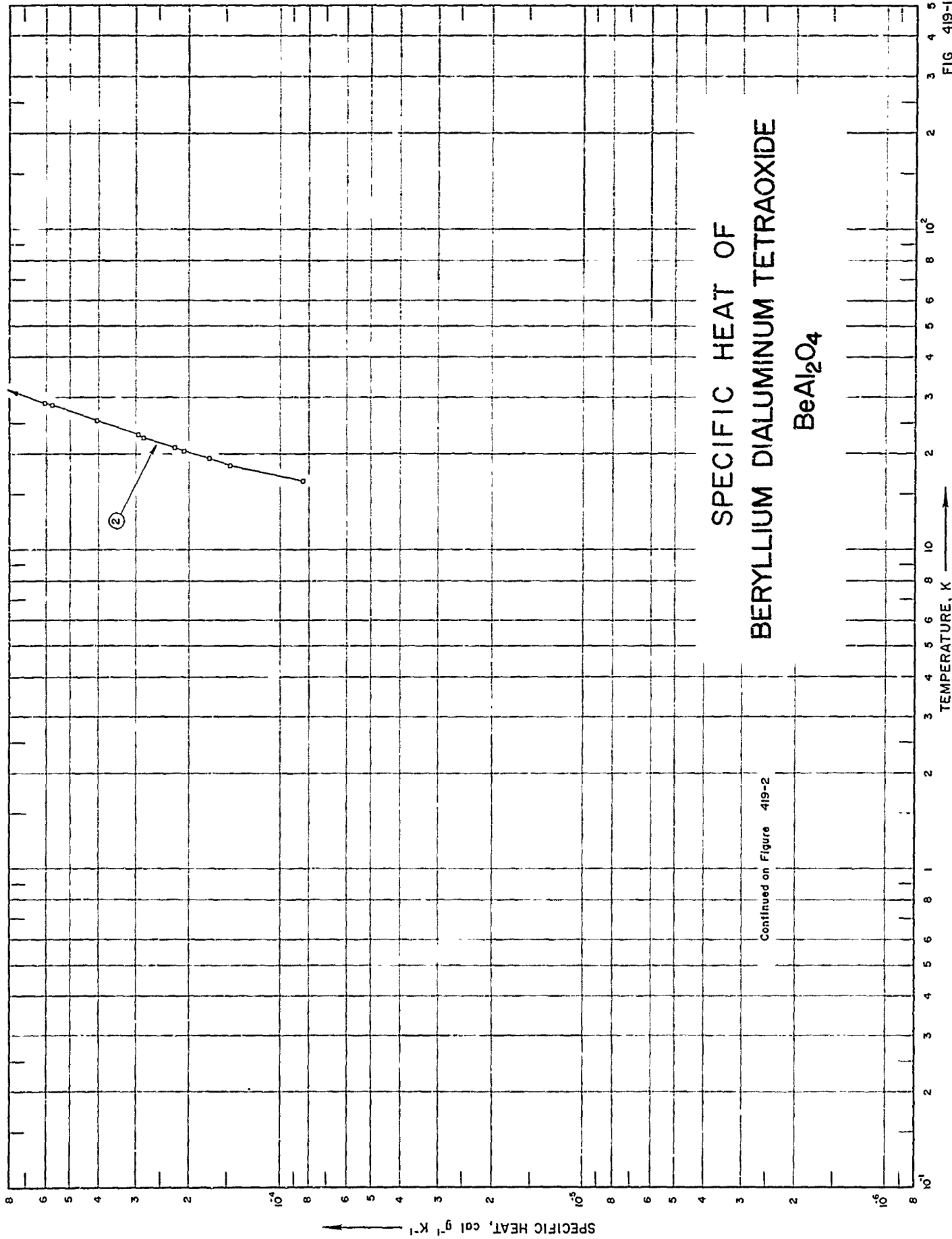

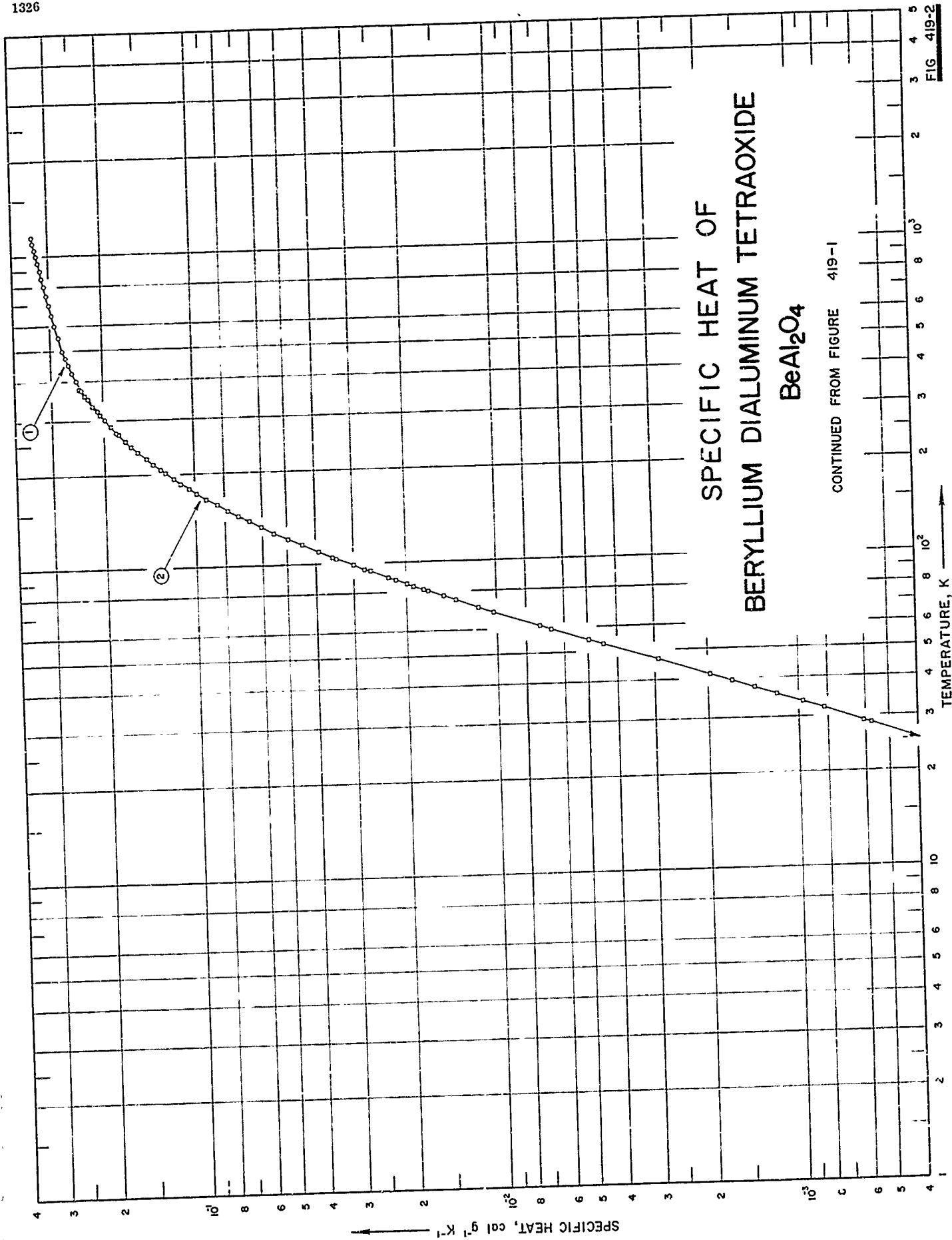

FIG. 419-2

SPECIFICATION TABLE NO. 419 SPECIFIC HEAT OF BERYLLIUM DIALUMINUM TETRAOXIDE BeAl_2O_4

[For Data Reported in Figure and Table No. 419]

Curve No.	Ref. No.	Year	Temp. Range, K	Reported Error, %	Name and Specimen Designation	Composition (weight percent), Specifications and Remarks
1	170	1964	273-1150			Two samples; average composition: 80.605 Al_2O_3 , 19.385 BeO .
2	170	1964	16-376	~0.5		80.33 Al_2O_3 , 19.72 BeO , < 0.01 Si , 0.01-0.1 Cu , 0.01-0.1 Ni , 0.001-0.01 Fe , 0.001-0.01 Mg , 0.001-0.01 Ca , < 0.001 P , < 0.001 Sn , < 0.0001 Ag , 0.0001-0.001 V .

DATA TABLE NO. 419 SPECIFIC HEAT OF BERYLLIUM DIALUMINUM TETRAOXIDE BeAl_2O_4 [Temperature, T, K; Specific Heat, C_p , Cal $\text{g}^{-1} \text{K}^{-1}$]

T	C_p	T	C_p	T	C_p	T	C_p
<u>CURVE 1</u>		<u>CURVE 2 (cont.)</u>		<u>CURVE 2 (cont.)</u>		<u>CURVE 2 (cont.)</u>	
273.15	1.825×10^{-1}	Series 2 (cont.)		Series 6		Series 11	
300	1.994	87.77	2.175×10^{-2}	19.27	1.732×10^{-4}	290.04	$1.934 \times 10^{-1*}$
310	2.051*	93.64	2.593*	20.86	2.259	298.76	1.989*
320	2.107	99.65	3.054*	22.85	2.974	307.34	2.037*
330	2.159*	105.46	3.529	25.21	4.066	315.98	2.086*
340	2.209*	110.76	3.983*	Series 7		324.77	2.133*
350	2.257	116.06	4.456	16.45	8.471×10^{-6}	333.56	2.179
360	2.304*	121.65	4.969	18.36	1.437×10^{-4}	342.23	2.223*
370	2.349*	127.48	5.518	20.29	2.108	350.99	2.265*
373.15	2.363	133.33	6.080	22.43	2.861	359.52	2.305
380	2.393*	139.15	6.650	25.25	4.009*	367.87	2.343*
390	2.433*	145.06	7.230	28.29	5.760	376.16	2.389
400	2.468	151.29	7.856	31.71	8.245	Series 12*	
425	2.544	158.10	8.520	35.40	1.178×10^{-3}	191.34	1.171×10^{-1}
450	2.611	165.13	9.211	39.33	1.651	201.13	1.260
475	2.671	172.47	9.926	Series 8		210.42	1.343
500	2.724	179.45	1.060 $\times 10^{-1}$	201.80	1.266×10^{-1}	219.29	1.428
550	2.815	186.11	1.123	207.60	1.318		
600	2.892	193.04	1.187	215.40	1.385		
700	3.018	Series 3		224.07	1.458		
750	3.072	54.60	4.963×10^{-3}	Series 9			
800	3.122	61.07	7.213	209.69	$1.336 \times 10^{-1*}$		
850	3.169	68.19	1.025×10^{-2}	215.47	1.411*		
900	3.213	75.12	1.376	227.35	1.480*		
950	3.256	81.41	1.750*	236.67	1.559		
1000	3.296	87.36	2.147*	246.31	1.633		
1050	3.336	Series 4		255.83	1.703		
1100	3.374	70.90	1.154×10^{-2}	269.06	1.795		
1150	3.411	77.52	1.512	277.90	1.857*		
<u>CURVE 2</u>		83.68	1.898	286.53	1.912		
Series 1		89.79	2.316*	294.69	1.964*		
80.55	1.695×10^{-2}	95.99	2.770	303.14	2.013*		
85.15	1.995	Series 5		311.51	2.061		
89.58	2.299	28.70	6.080×10^{-4}	320.02	2.108*		
94.16	2.630	33.31	9.694	Series 10			
99.08	3.008	37.31	1.397×10^{-3}	309.76	$2.051 \times 10^{-1*}$		
104.31	3.432	41.46	1.963	317.73	2.095*		
109.84	3.902	46.63	2.918				
Series 2		52.97	4.446				
81.62	1.763×10^{-2}	59.56	6.628				

* Not shown on plot

SPECIFIC HEAT OF
DIBERYLLIUM SILICON TETRAOXIDE
 Be_2SiO_4

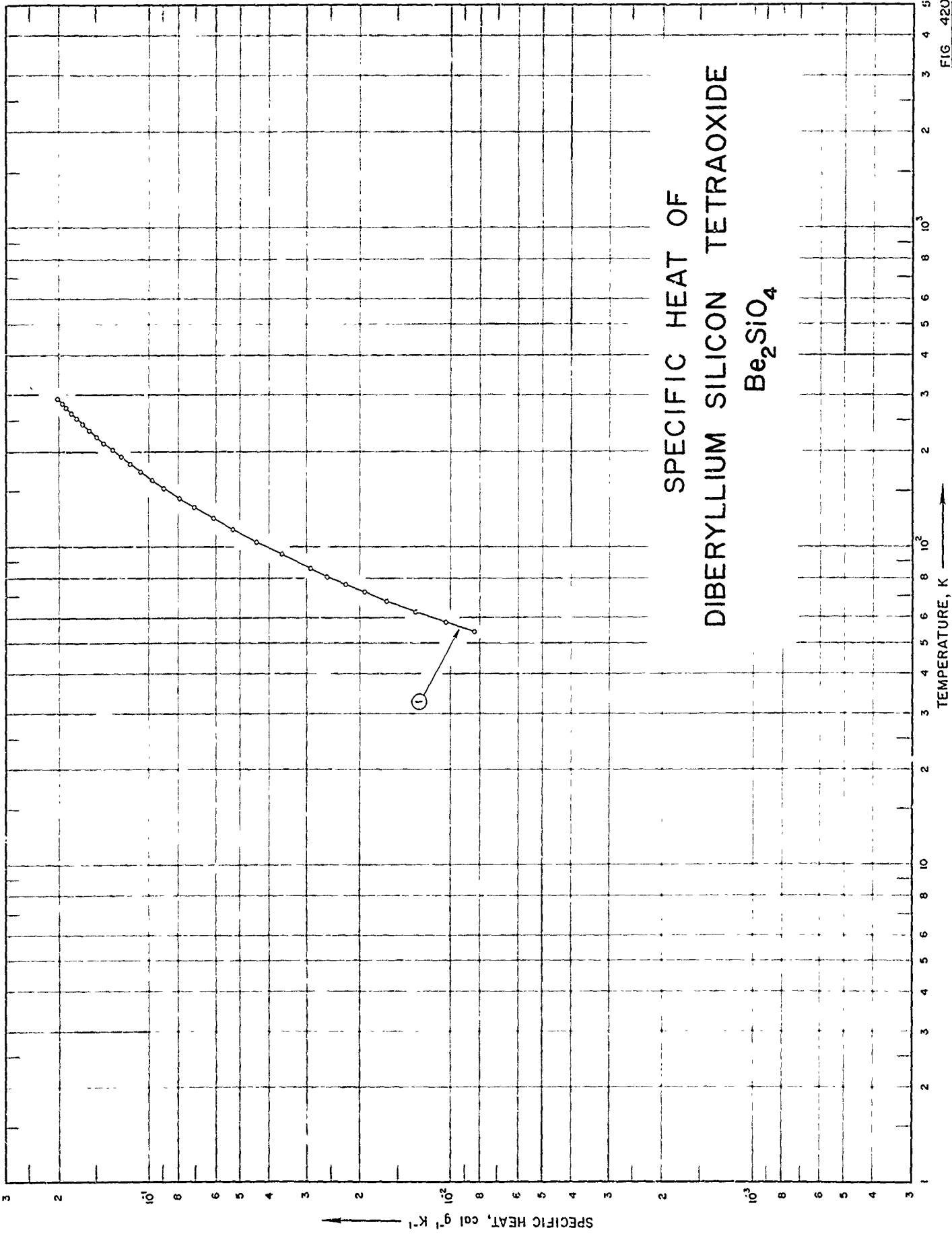

SPECIFICATION TABLE NO. 420 SPECIFIC HEAT OF DIBERYLLIUM SILICON TETRAOXIDE Be_2SiO_4

[For Data Reported in Figure and Table No. 420]

Curve No.	Ref. No.	Year	Temp. Range, K	Reported Error, %	Name and Specimen Designation	Composition (weight percent), Specifications and Remarks
1	43	1939	55-294			99.9 Be_2SiO_4 ; well crystallized; sample from Brazil; 99.8 Be_2SiO_4 poorly crystallized; sample from Colorado; measurements made from 126.5 g of Brazil sample and 83.5 g of Colorado sample.

DATA TABLE NO. 420 SPECIFIC HEAT OF DIBERYLLIUM SILICON TETRAOXIDE Be_2SiO_4 [Temperature, T, K; Specific Heat, C_p , Cal $\text{g}^{-1} \text{K}^{-1}$]

T	C_p
54.7	8.492×10^{-3}
58.6	1.054×10^{-2}
63.3	1.323
68.2	1.653
72.6	1.960
76.6	2.252
81.4	2.607
86.1	2.955
95.0	3.668
104.5	4.461
114.5	5.349
124.3	6.242
134.6	7.178
143.9	8.035
154.3	9.020
163.9	9.873
174.0	1.078×10^{-1}
184.2	1.171
193.6	1.255
203.8	1.345
213.7	1.431
223.8	1.515
234.5	1.604
245.3	1.688
255.5	1.763
265.3	1.836
275.2	1.913
284.4	1.973
294.1	2.042

CURVE 1

SPECIFIC HEAT OF
CALCIUM DIALUMINUM TETRAOXIDE
 CaAl_2O_4

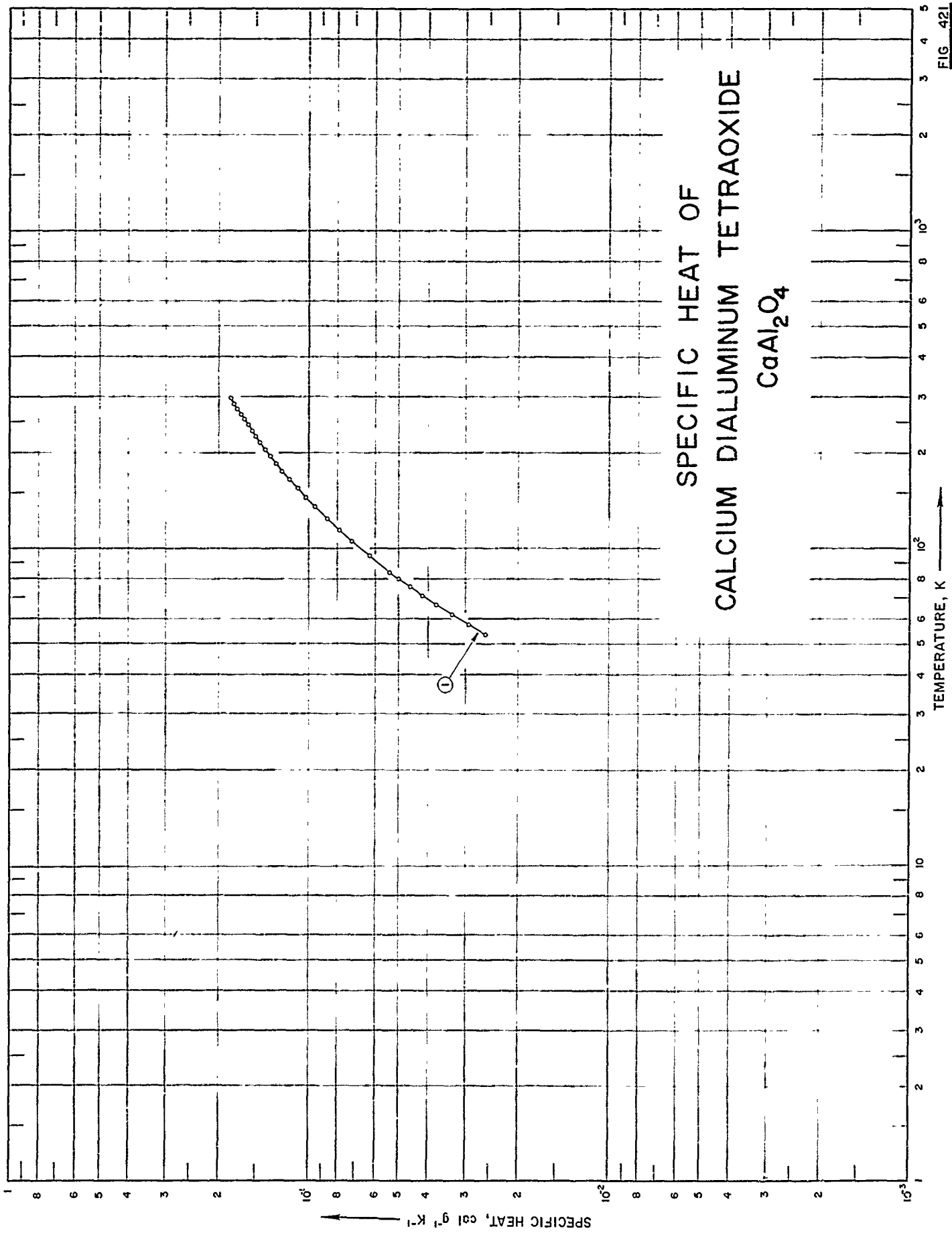

FIG. 421

SPECIFICATION TABLE NO. 421 SPECIFIC HEAT OF CALCIUM DIALUMINUM TETRAOXIDE CaAl_2O_4

[For Data Reported in Figure and Table No. 421]

Curve No.	Ref. No.	Year	Temp. Range, K	Reported Error, %	Name and Specimen Designation	Composition (weight percent), Specifications and Remarks
1	365	1955	54-298			64.44 Al_2O_3 , 35.49 CaO (64.51, 35.49 theo.).

DATA TABLE NO. 421 SPECIFIC HEAT OF CALCIUM DIALUMINUM TETRAOXIDE CaAl_2O_4 [Temperature, T, K; Specific Heat, C_p , Cal $\text{g}^{-1} \text{K}^{-1}$]

T	C_p
	<u>CURVE 1</u>
53.52	2.577×10^{-2}
57.74	2.937
61.99	3.334
66.52	3.762
71.16	4.186
75.79	4.596
80.40	5.013
84.45	5.382
94.66	6.272
106.15	7.232
114.76	7.941
124.65	8.726
136.22	9.599
145.72	1.029×10^{-1}
155.70	1.097
166.66	1.171
176.04	1.231
185.85	1.291
196.25	1.351
206.07	1.403
216.32	1.462
225.07	1.511
235.98	1.560
246.07	1.609
256.37	1.653
266.38	1.698
276.71	1.741
286.54	1.782
296.30	1.815*
298.16	1.824

* Not shown on plot

SPECIFIC HEAT OF
CALCIUM TETRAALUMINUM HEPTAOXIDE
 CaAl_4O_7

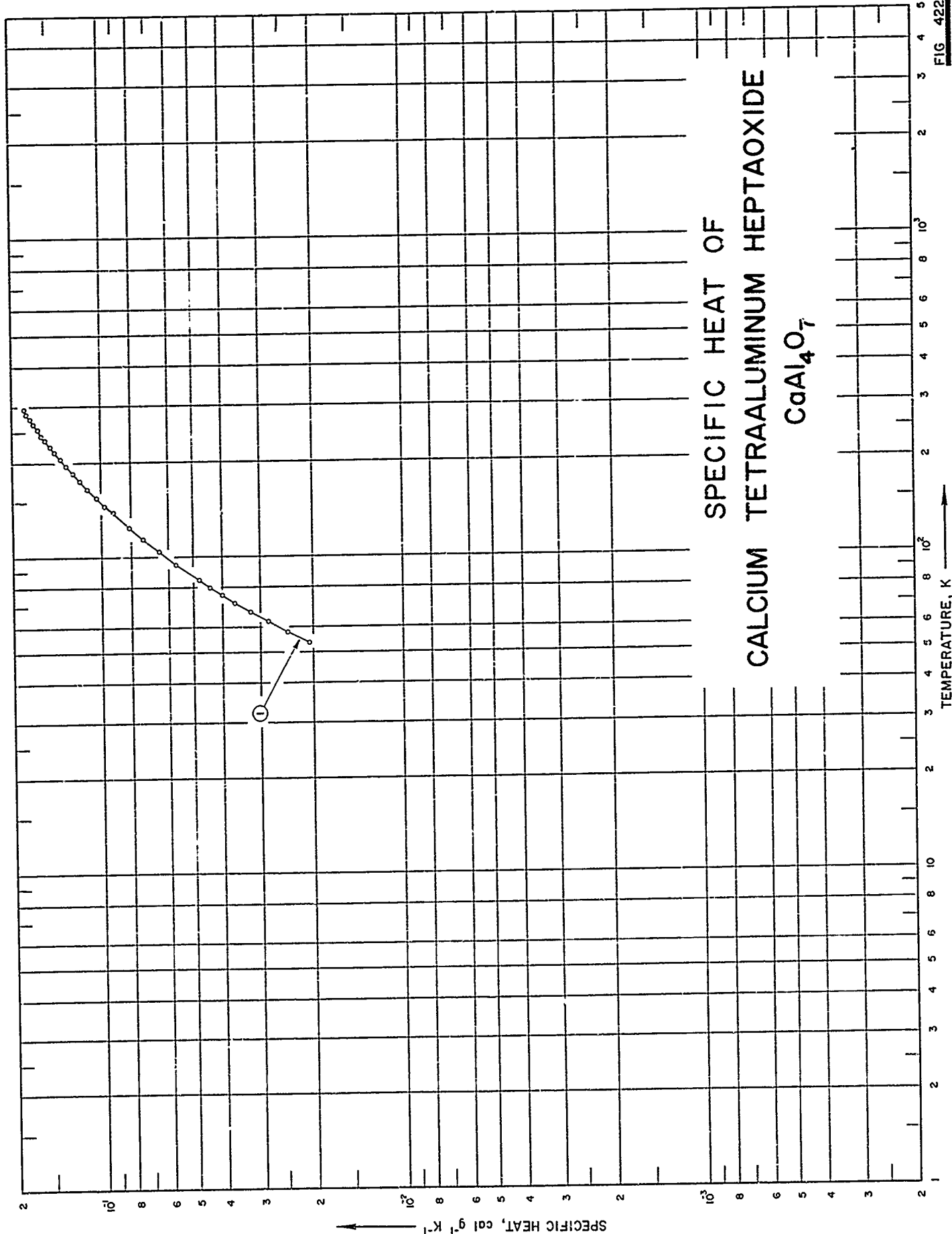

SPECIFICATION TABLE NO. 422 SPECIFIC HEAT OF CALCIUM TETRAALUMINUM HEPTAOXIDE $\text{Ca}_4\text{Al}_7\text{O}_{17}$

[For Data Reported in Figure and Table No. 422]

Curve No.	Ref. No.	Year	Temp. Range, K	Reported Error, %	Name and Specimen Designation	Composition (weight percent), Specifications and Remarks
1	365	1955	54-296			78.49 Al_2O_3 , 21.58 CaO (78.43, 27.58 theo.).

DATA TABLE NO. 422 SPECIFIC HEAT OF CALCIUM TETRAALUMINUM HEPTAOXIDE CrAl_4O_7 [Temperature, T, K; Specific Heat, C_p , Cal $\text{g}^{-1} \text{K}^{-1}$]

T	C_p
	CURVE 1
53.50	2.061×10^{-2}
57.99	2.427
62.54	2.830
67.11	3.233
71.69	3.642
76.24	4.035
80.30	4.404
84.70	4.792
94.76	5.673
104.97	6.538
114.78	7.373
124.71	8.169
138.27	9.242
146.60	9.865
155.94	1.053×10^{-1}
165.81	1.124
175.84	1.192
185.76	1.257
195.98	1.321
206.37	1.381
216.13	1.440
226.25	1.495
236.04	1.545
243.88	1.598
256.26	1.649
266.25	1.696
276.42	1.741
286.60	1.790
296.35	1.823

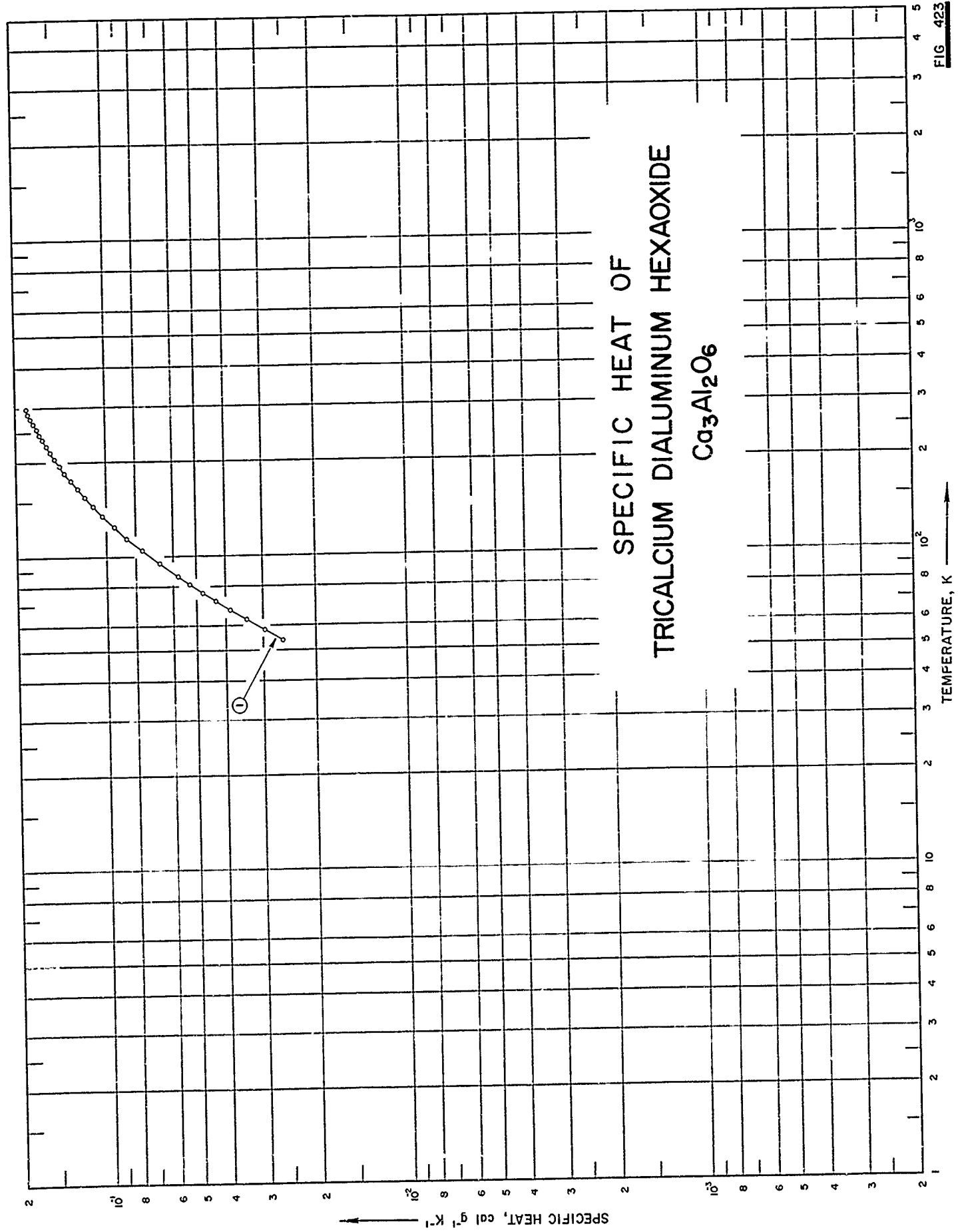

FIG. 423

SPECIFICATION TABLE NO. 423 SPECIFIC HEAT OF TRICALCIUM DIALUMINUM HEXAOXIDE $\text{Ca}_3\text{Al}_2\text{O}_6$

[For Data Reported in Figure and Table No. 423]

Curve No.	Ref. No.	Year	Temp. Range, K	Reported Error, %	Name and Specimen Designation	Composition (weight percent), Specifications and Remarks
1	365	1955	54-297			62.25 CaO, 37.84 Al_2O_3 (62.26, 37.74 theo.).

DATA TABLE NO. 423 SPECIFIC HEAT OF TRICALCIUM DIALUMINUM HEXAOXIDE $\text{Ca}_3\text{Al}_2\text{O}_6$
 [Temperature, T, K; Specific Heat, C_p , Cal $\text{g}^{-1}\text{K}^{-1}$]

T	C_p
	<u>CURVE 1</u>
53.86	2.600×10^{-2}
58.06	2.988
58.29	3.004*
62.58	3.441
62.80	3.453*
67.09	3.901
71.65	4.356
76.22	4.808
81.20	5.322
86.39	5.840
94.90	6.680
105.00	7.642
114.74	8.571
124.92	9.445
135.88	1.037×10^{-1}
145.54	1.111
155.59	1.184
165.92	1.257
176.02	1.321
185.96	1.382
195.92	1.436
206.35	1.491
216.23	1.541
226.03	1.586
236.29	1.633
245.83	1.674
256.54	1.714
266.41	1.753
276.33	1.789
286.51	1.823
296.54	1.849

* Not shown on plot

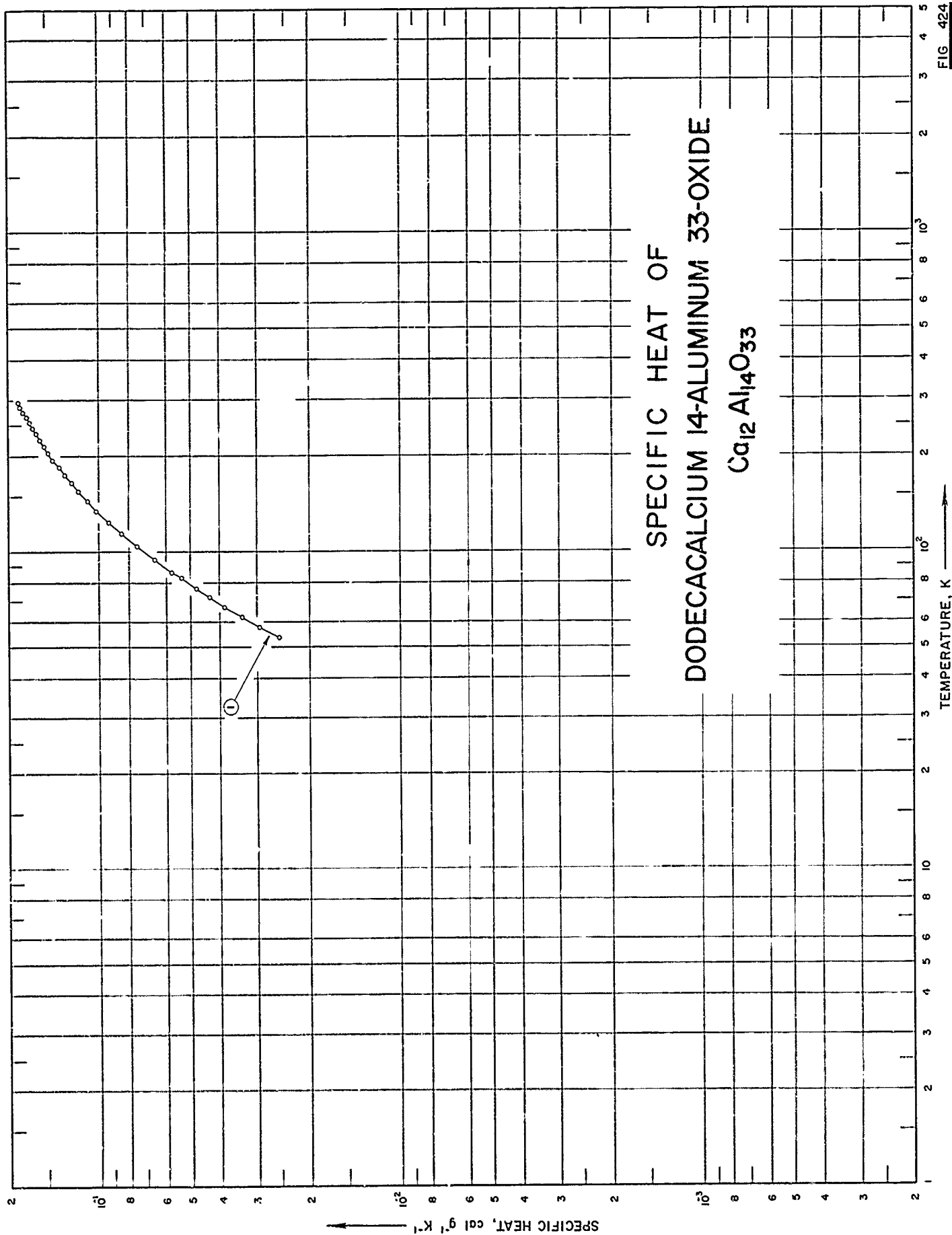

SPECIFICATION TABLE NO. 424 SPECIFIC HEAT OF DODECACALCIUM 14-ALUMINUM 33-OXIDE $\text{Ca}_{12}\text{Al}_{14}\text{O}_{33}$

[For Data Reported in Figure and Table No. 424]

Curve No.	Ref. No.	Year	Temp. Range, K	Reported Error, %	Name and Specimen Designation	Composition (weight percent), Specifications and Remarks
1	365	1955	54-297			51.2 Al_2O_3 , 48.32 CaO (51.47, 48.32 theo.), 0.25 MgO + alkali oxides, 0.10 Fe_2O_3 .

DATA TABLE NO. 424 SPECIFIC HEAT OF DODECACALCIUM 14-ALUMINUM 33-OXIDE $\text{Ca}_{12}\text{Al}_{14}\text{O}_{33}$ [Temperature, T, K; Specific Heat, C_p , Cal $\text{g}^{-1} \text{K}^{-1}$]

T	C_p
53.89	2.529×10^{-2}
58.20	2.930
62.50	3.363
67.20	3.842
72.00	4.320
76.63	4.786
82.00	5.331
86.21	5.753
94.55	6.568
104.79	7.536
114.69	8.459
124.87	9.346
135.98	1.025×10^{-1}
145.55	1.100
156.38	1.180
165.74	1.245
175.78	1.309
185.56	1.369
195.72	1.429
206.15	1.483
216.04	1.533
225.99	1.581
235.94	1.630
245.78	1.672
256.20	1.714
266.08	1.755
276.25	1.794
286.54	1.831
296.75	1.863

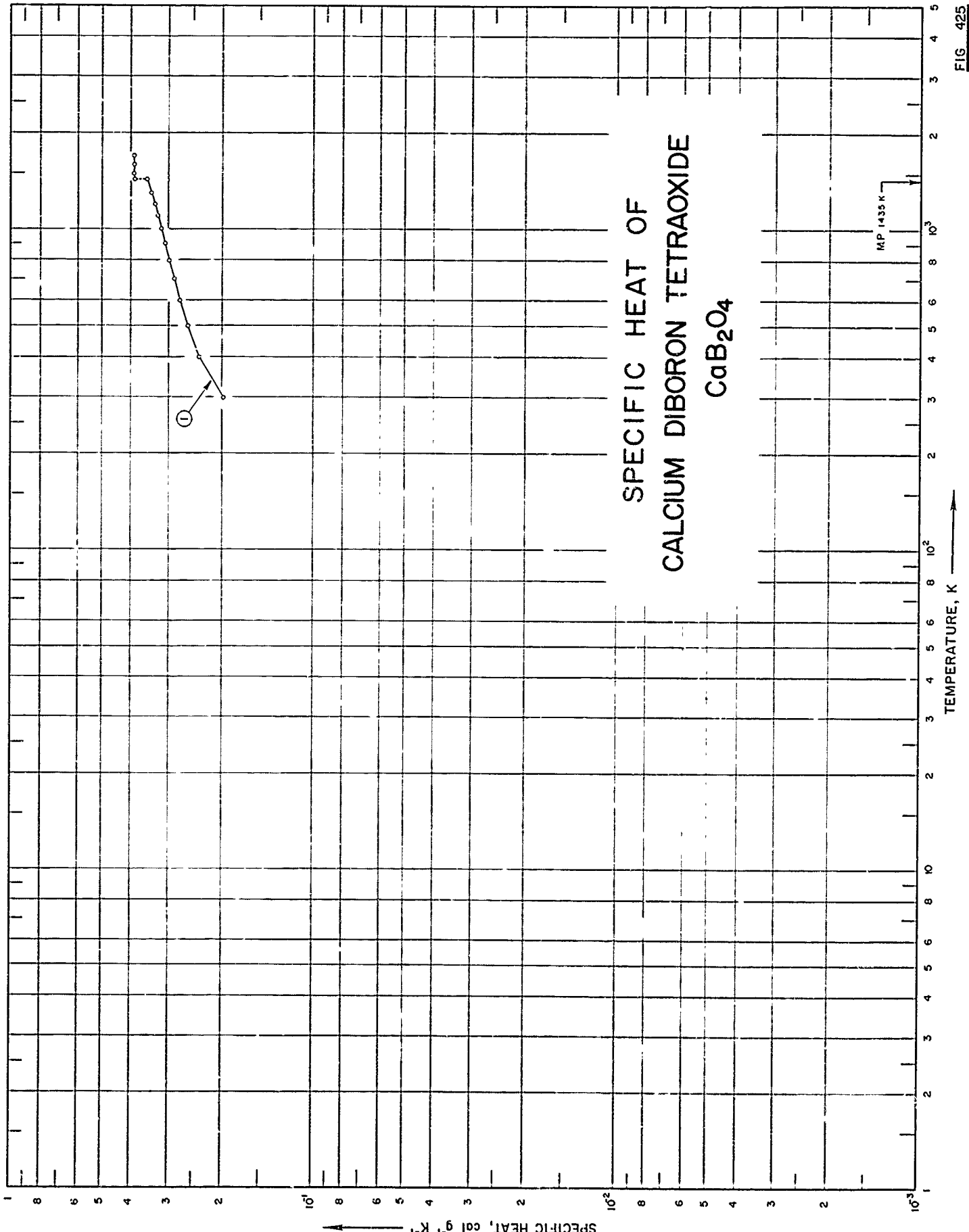

SPECIFICATION TABLE NO. 425 SPECIFIC HEAT OF CALCIUM DIBORON TETRAOXIDE CaB_2O_4

[For Data Reported in Figure and Table No. 425]

Curve No.	Ref. No.	Year	Temp. Range, K	Reported Error, %	Name and Specimen Designation	Composition (weight percent), Specifications and Remarks
1	366	1948	298-1700			

DATA TABLE NO. 425 SPECIFIC HEAT OF CALCIUM DIBORON TETRAOXIDE CaB_2O_4 [Temperature, T, K; Specific Heat, C_p , Cal $\text{g}^{-1} \text{K}^{-1}$]

T	C_p
	<u>CURVE 1</u>
300	1.985×10^{-1}
400	2.38
500	2.60
600	2.76
700	2.80
800	2.99
900	3.09
1000	3.18
1100	3.27
1200	3.35
1300	3.44
1400	3.52*
(s) 1435	3.55
(L) 1435	4.91
1500	4.91
1600	4.91
1700	4.91

* Not shown on plot

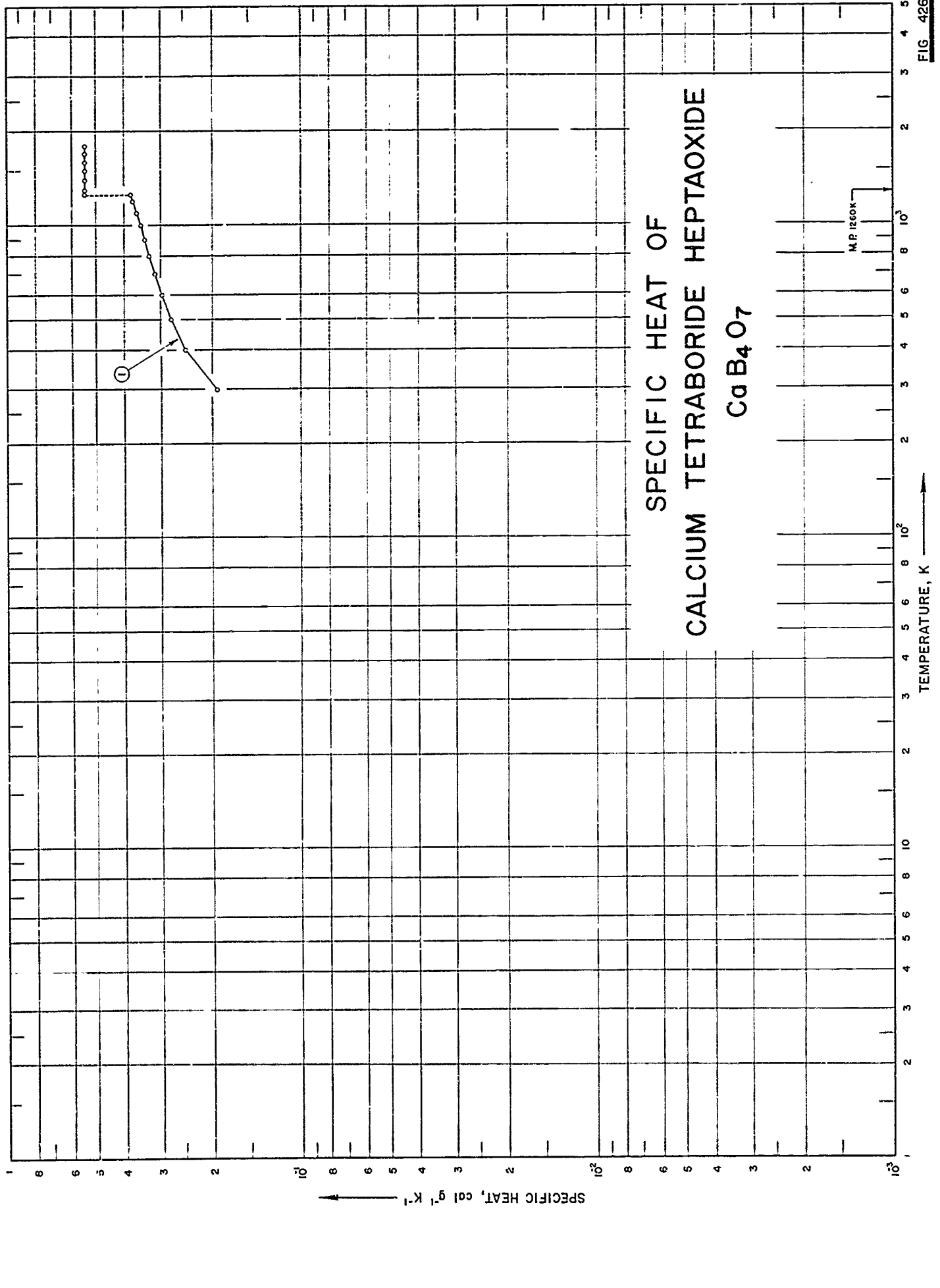

SPECIFICATION TABLE NO. 426 SPECIFIC HEAT OF CALCIUM TETRABORON HEPTAOXIDE CaB_4O_7

[For Data Reported in Figure and Table No. 426]

Curve No.	Ref. No.	Year	Temp. Range, K	Reported Error, %	Name and Specimen Designation	Composition (weight percent), Specifications and Remarks
1	366	1948	278-1800			

DATA TABLE NO. 426 SPECIFIC HEAT OF CALCIUM TETRABORON HEPTAOXIDE CaB_4O_7
 [Temperature, T, K; Specific Heat, C_p , $\text{Cal g}^{-1} \text{K}^{-1}$]

T	C_p
CURVE 1	
298	1.931×10^{-1}
300	1.946*
400	2.471
500	2.767
600	2.972
700	3.135
800	3.275
900	3.402
1000	3.521
1100	3.634
1200	3.744
1260	3.808
1260	5.441
1300	5.441
1400	5.441
1500	5.441
1600	5.441
1700	5.441
1800	5.441

* Not shown on plot

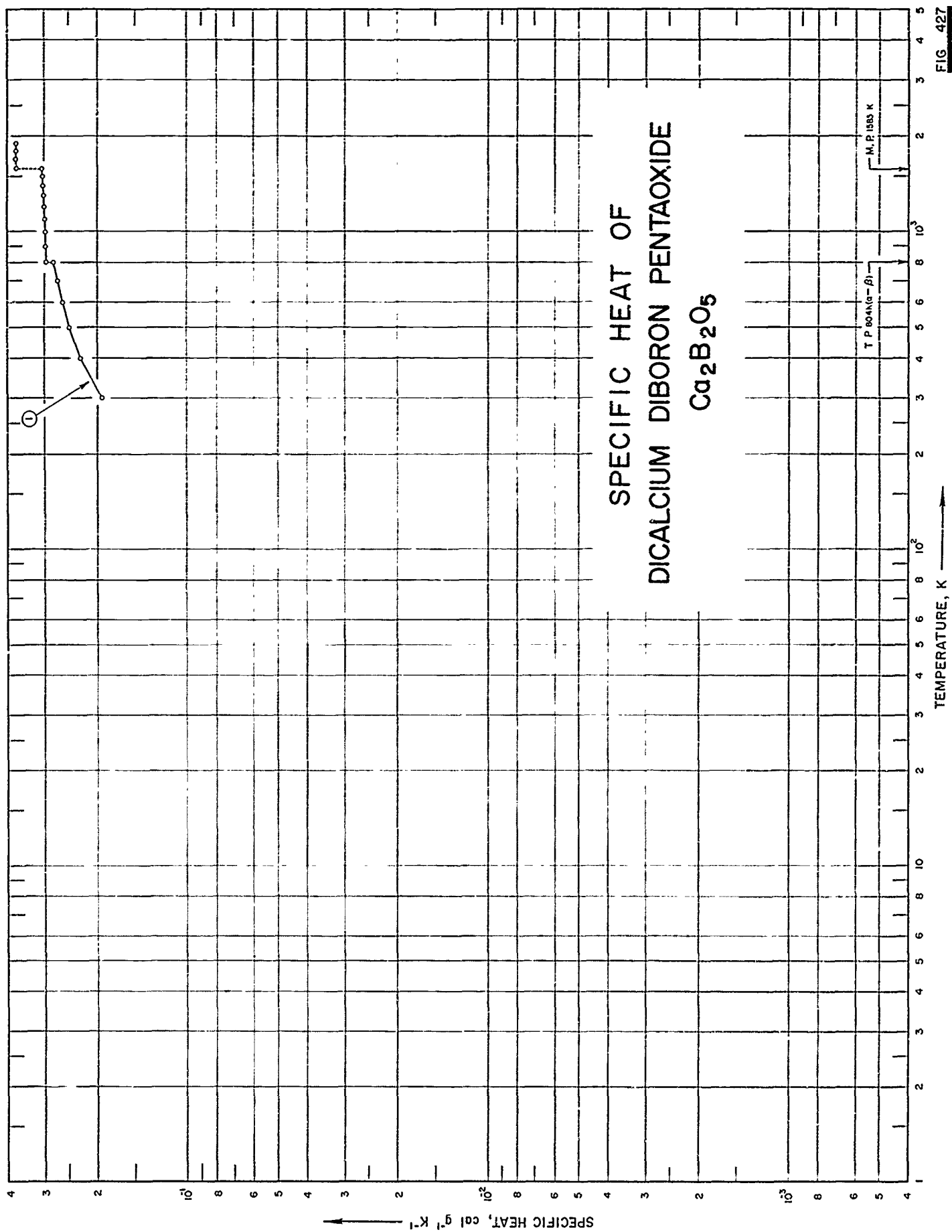

FIG. 427

SPECIFICATION TABLE NO. 427 SPECIFIC HEAT OF DICALCIUM DIBORON PENTAOXIDE $\text{Ca}_2\text{B}_2\text{O}_6$

[For Data Reported in Figure and Table No. 427]

Curve No.	Ref. No.	Year	Temp. Range, K	Reported Error, %	Name and Specimen Designation	Composition (weight percent), Specifications and Remarks
1	366	1948	298-1900			α and β crystals.

DATA TABLE NO. 427 SPECIFIC HEAT OF DICALCIUM DIBORON PENTAOXIDE $\text{Ca}_2\text{B}_2\text{O}_7$
 [Temperature, T, K; Specific Heat, C_p , Cal $\text{g}^{-1}\text{K}^{-1}$]

T	C_p
<u>CURVE 1</u>	
300	1.94×10^{-1}
400	2.29
500	2.49
600	2.62
700	2.73
(α) 804	2.82
(β) 804	2.98
900	2.99
1000	3.00
1100	3.02
1200	3.03
1300	3.05
1400	3.06
1500	3.07
(β) 1585	3.095
(δ) 1585	3.75
1600	3.75*
1700	3.75*
1800	3.75*
1900	3.75

* Not shown on plot

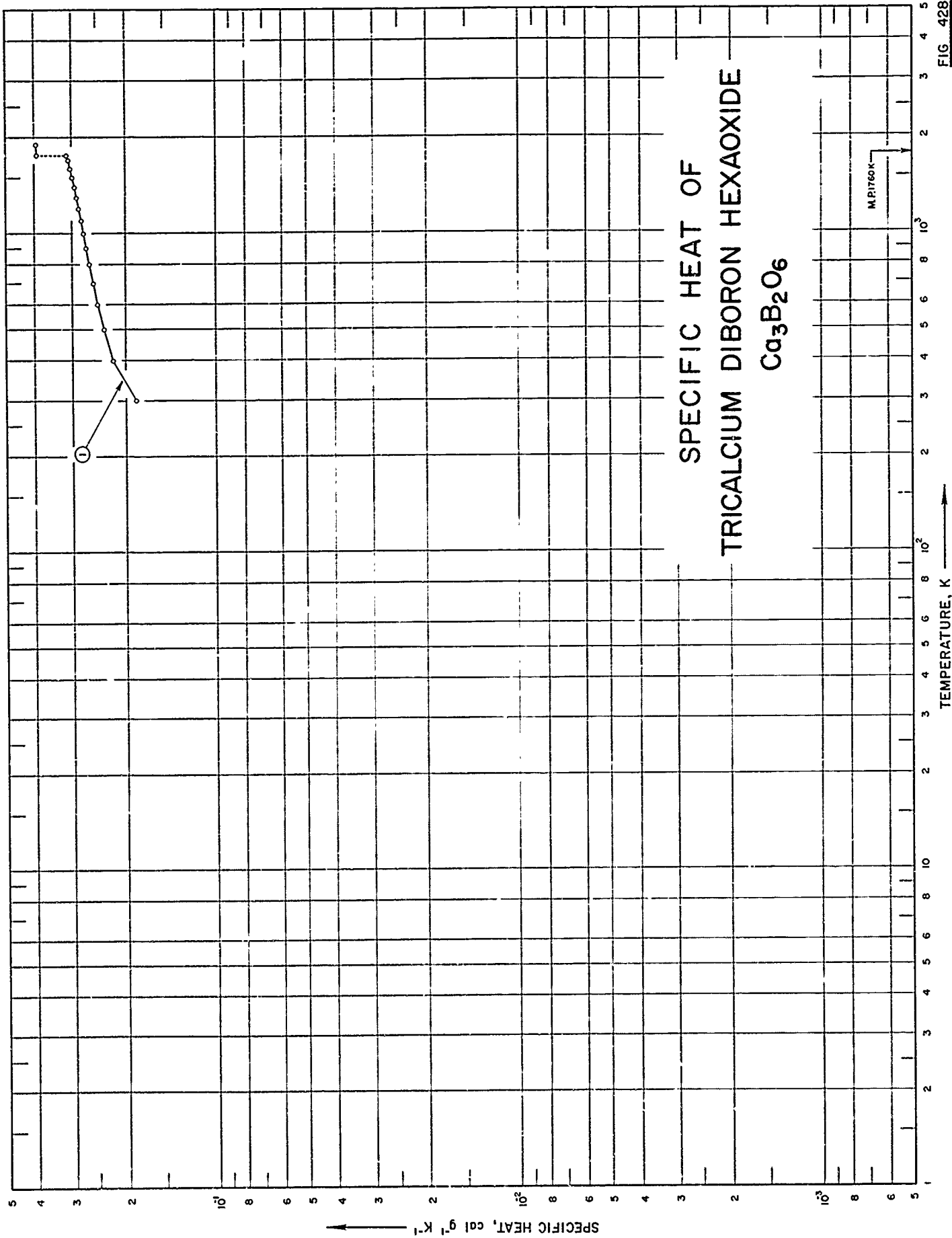

SPECIFIC HEAT OF
TRICALCIUM DIBORON HEXAOXIDE
 $Ca_3B_2O_6$

M.P. 1760 K

SPECIFIC HEAT, $cal\ g^{-1}\ K^{-1}$

TEMPERATURE, K

SPECIFICATION TABLE NO. 428 SPECIFIC HEAT OF TRICALCIUM DIBORON HEXAOXIDE $\text{Ca}_3\text{B}_2\text{O}_6$

[For Data Reported in Figure and Table No. 428]

Curve No.	Ref. No.	Year	Temp. Range, K	Reported Error, %	Name and Specimen Designation	Composition (weight percent), Specifications and Remarks
1	366	1948	298-1900		Colemanite	

DATA TABLE NO. 428 SPECIFIC HEAT OF TRICALCIUM DIBORON HEXAOXIDE $\text{Ca}_3\text{B}_2\text{O}_8$: Temperature, T, K; Specific Heat, C_p , Cal $\text{g}^{-1} \text{K}^{-1}$

T	C_p
300	1.859 $\times 10^{-1}$
400	2.20
500	2.37
600	2.48
700	2.57
800	2.64
900	2.70
1000	2.76
1100	2.81
1200	2.87
1300	2.91
1400	2.95
1500	3.00
1600	3.05
1700	3.09
(s) 1760	3.13
(t) 1760	3.95
1800	3.95*
1900	3.95

* Not shown on plot

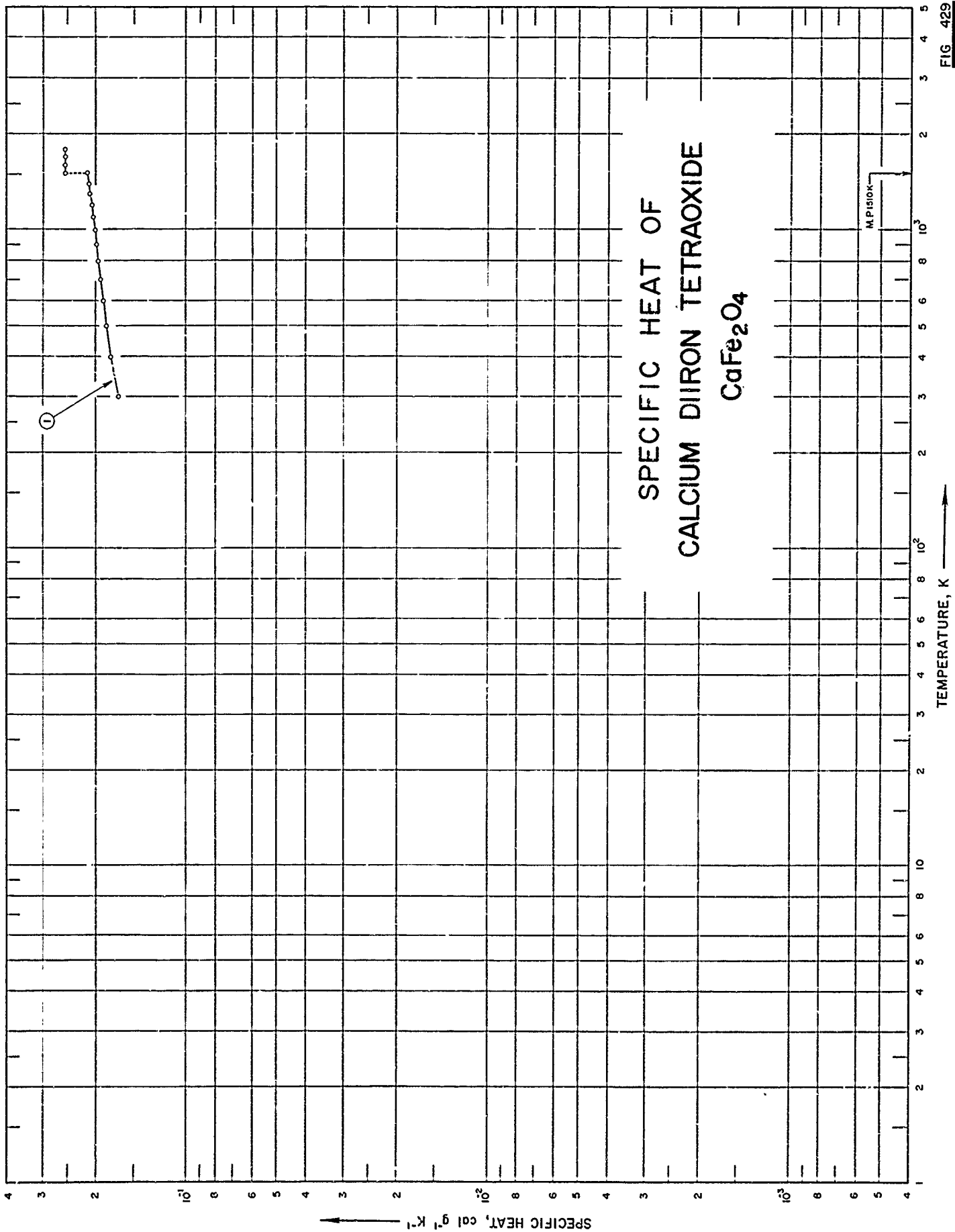

FIG. 429

SPECIFICATION TABLE NO. 429 SPECIFIC HEAT OF CALCIUM DIKON TETRAOXIDE CaFe_2O_4

[For Data Reported in Figure and Table No. 429]

Curve No.	Ref. No.	Year	Temp. Range, K	Reported Error, %	Name and Specimen Designation	Composition (weight percent), Specifications and Remarks
1	367	1954	298-1800			74.05 Fe_2O_3 , 26.05 CaO (74.0, 25.99 theo.); prepared from reagent-grade Fe_2O_3 and CaCO_3 ; ground mixed; heated to 1000-1200 C for several hrs; repeated several times adjusting composition between heating cycles.

DATA TABLE NO. 429 SPECIFIC HEAT OF CALCIUM DIIRON TETRAOXIDE CaFe_2O_4 [Temperature, T, K; Specific Heat, C_p , Cal $\text{g}^{-1} \text{K}^{-1}$]

T	C_p
	<u>CURVE 1</u>
300	1.70×10^{-1}
400	1.81
500	1.87
600	1.91
700	1.95
800	1.98
900	2.00
1000	2.03
1100	2.06
1200	2.08
1300	2.10
1400	2.13
1500	2.15*
(s) 1510	2.15
(t) 1510	2.54
1600	2.54
1700	2.54
1800	2.54

* Not shown on plot

FIG. 430

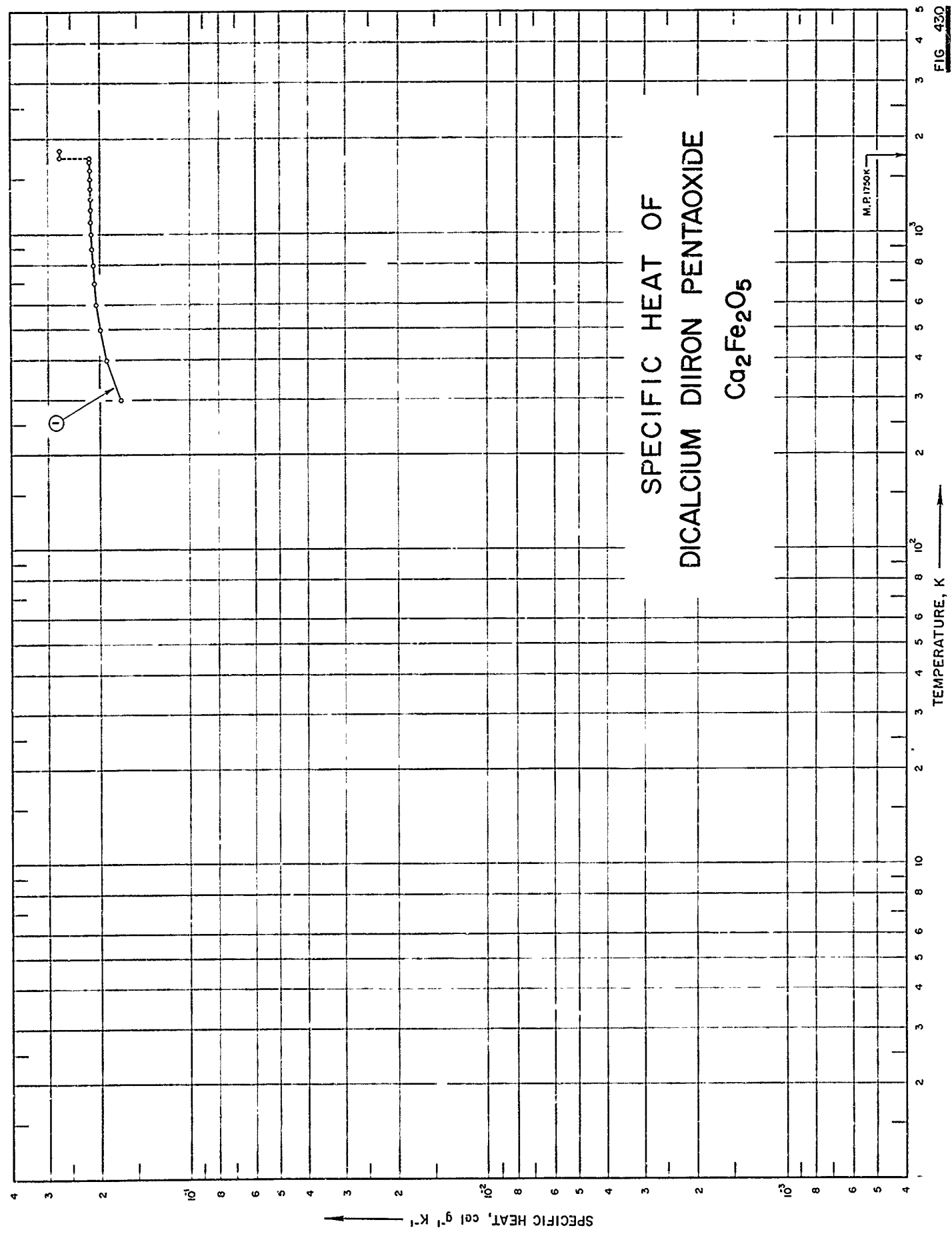

SPECIFICATION TABLE NO. 430 SPECIFIC HEAT OF DICALCIUM DIIRON PENTAOXIDE $\text{Ca}_2\text{Fe}_2\text{O}_5$

[For Data Reported in Figure and Table No. 430]

Curve No.	Ref. No.	Year	Temp. Range, K	Reported Error, %	Name and Specimen Designation	Composition (weight percent), Specifications and Remarks
1	367	1954	298-1850			58.71 Fe_2O_3 , 41.27 CaO ; prepared from reagent-grade Fe_2O_3 and CaCO_3 ; ground mixed; heated to 850-1230 C for several hrs; repeated several times adjusting composition between heating cycles.

DATA TABLE NO. 430 SPECIFIC HEAT OF DICALCIUM DIIRON PENTAOXIDE $\text{Ca}_2\text{Fe}_2\text{O}_6$
 [Temperature, T, K; Specific Heat, C_p , Cal $\text{g}^{-1}\text{K}^{-1}$]

T	C_p
	<u>CURVE 1</u>
300	1.70×10^{-1}
400	1.91
500	2.01
600	2.06
700	2.09
800	2.11
900	2.13
1000	2.14
1100	2.15
1200	2.15
1300	2.158
1400	2.16
1500	2.165
1600	2.165
1700	2.17
(s) 1750	2.17
(k) 1750	2.73
1800	2.73*
1850	2.73

* Not shown on plot

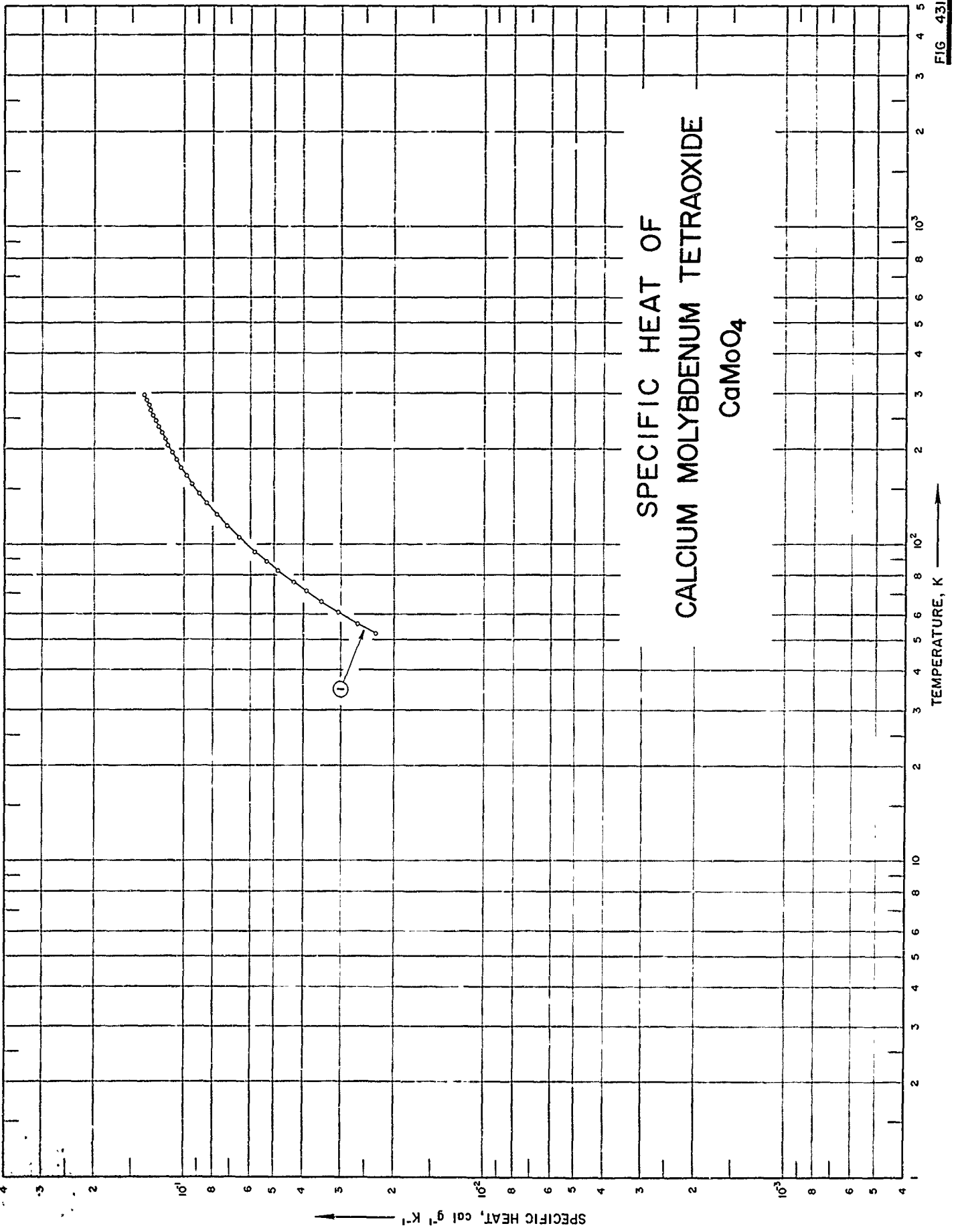

FIG 431

SPECIFICATION TABLE NO. 431 SPECIFIC HEAT OF CALCIUM MOLYBDENUM TETRAOXIDE CaMoO_4

[For Data Reported in Figure and Table No. 431]

Curve No.	Ref. No.	Year	Temp. Range, K	Reported Error, %	Name and Specimen Designation	Composition (weight percent), Specifications and Remarks
1	368	1963	52-296	0.3		71.98 MoO_3 , 28.08 CaO ; prepared from stoichiometric mixture of reagent-grade CaCO_3 and MoC , by heating at 500-570 C for 9 days; followed by heating at 600-690 C for 10 days.

DATA TABLE NO. 431 SPECIFIC HEAT OF CALCIUM MOLYBDENUM TETRAOXIDE CaMoO_4 [Temperature, T, K; Specific Heat, C_p , Cal $\text{g}^{-1} \text{K}^{-1}$]

T	C_p
	<u>CURVE 1</u>
52.32	2.300×10^{-2}
56.36	2.641
61.12	3.069
65.99	3.480
71.02	3.900
75.98	4.316
82.71	4.870
88.12	5.294
94.61	5.814
105.56	6.559
114.85	7.174
124.78	7.789
135.84	8.409
145.71	8.924
155.92	9.419
165.95	9.849
175.93	1.025×10^{-1}
186.01	1.063
195.89	1.098
205.36	1.133
216.27	1.165
226.38	1.194
235.29	1.221
246.29	1.248
256.55	1.275
266.45	1.297
276.46	1.319
286.95	1.342
296.43	1.364

SPECIFIC HEAT OF
CALCIUM SILICON TRIOXIDE
CaSiO₃

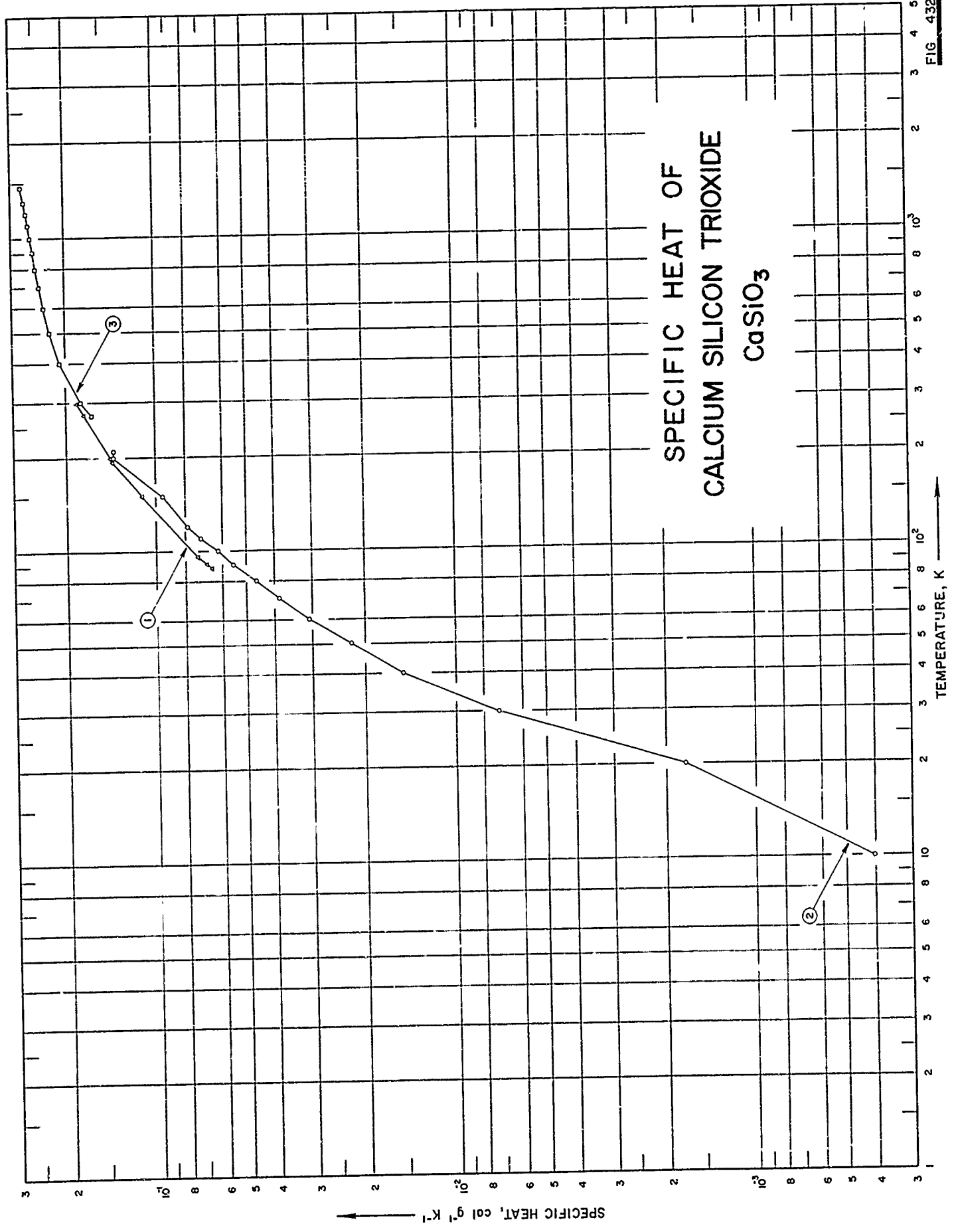

SPECIFICATION TABLE NO. 432 SPECIFIC HEAT OF CALCIUM SILICON TRIOXIDE CaSiO_3

[For Data Reported in Figure and Table No. 432]

Curve No.	Ref. No.	Year	Temp. Range, K	Reported Error, %	Name and Specimen Designation	Composition (weight percent), Specifications and Remarks
1	372	1926	88-298	<1	pseudo Wollastonite	Synthetically prepared sample.
2	373	1934	10-210		Wollastonite	β -phase.
3	122	1941	273-1450	0.25	Wollastonite	51.52 SiO_2 , 47.85 CaO , 0.36 Fe_2O_3 ; natural mineral from Riverside County, California.

DATA TABLE NO. 432 SPECIFIC HEAT OF CALCIUM SILICON TRIOXIDE, CaSiO_3
 [Temperature, T, K; Specific Heat, C_p , Cal $\text{g}^{-1}\text{K}^{-1}$]

T	C_p
<u>CURVE 1</u>	
88.2	6.53×10^{-2}
91.1	6.78
92.3	6.84*
95.7	7.25
151.5	1.133×10^{-1}
194.7	1.396
199.4	1.416
275.4	1.735
278.2	1.754*
295.8	1.829*
298.3	1.832
<u>CURVE 2</u>	
10	4.0×10^{-1}
20	1.7×10^{-3}
30	7.2
40	1.5×10^{-2}
50	2.2
60	3.1
70	3.9
80	4.6
90	5.5
100	6.2
110	7.1
120	7.8
150	9.5
200	1.4×10^{-1}
210	1.4
<u>CURVE 3</u>	
273.15	1.635×10^{-1}
300	1.773
400	2.081
500	2.241
600	2.344
700	2.420
800	2.481
900	2.534
1000	2.581
1100	2.625
1200	2.667
1300	2.707
1400	2.746*
1450	2.765

* Not shown on plot

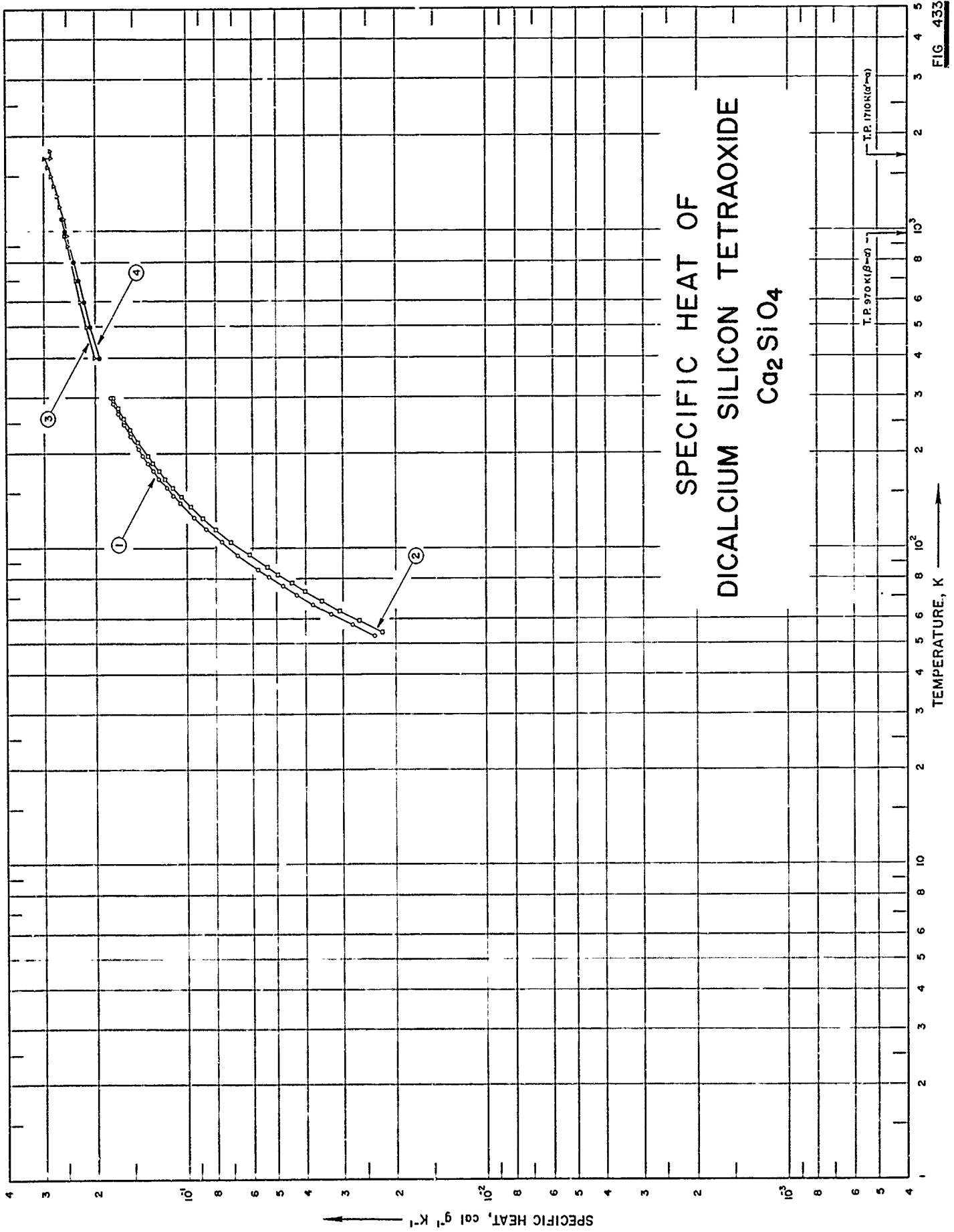

SPECIFICATION TABLE NO. 4³ SPECIFIC HEAT OF DICALCIUM SILICON TETRAOXIDE Ca₂SiO₄

[For Data Reported in Figure and Table No. 433]

Curve No.	Ref. No.	Year	Temp. Range, K	Reported Error, %	Name and Specimen Designation	Composition (weight percent), Specifications and Remarks
1	369	1951	53-298			64.47 CaO, 34.68 SiO ₂ (65.13, 34.57 theo.), 0.32 Fe ₂ O ₃ , 0.32 Al ₂ O ₃ , 0.14 MgO, 0.02 ignition loss; crystalline, β-phase.
2	370	1957	54-298			γ-phase.
3	371	1957	298-1800			64.47 CaO, 34.68 SiO ₂ , 0.32 Al ₂ O ₃ , 0.32 Fe ₂ O ₃ , 0.14 MgO, 0.02 H ₂ O; β, α, and α' phases.
4	371	1957	298-1100			34.88 SiO ₂ ; γ-phase; prepared from reagent-grade calcium carbonate and silica.

DATA TABLE NO. 433 SPECIFIC HEAT OF DICALCIUM SILICON TETRAOXIDE, Ca_2SiO_4 [Temperature, T, K; Specific Heat, C_p , Cal $\text{g}^{-1}\text{K}^{-1}$]

CURVE 1		CURVE 2 (cont.)		CURVE 3		CURVE 4	
T	C_p	T	C_p	T	C_p	T	C_p
52.66	2.371×10^{-2}	135.85	9.672×10^{-2}	298.15	1.760×10^{-6}		
57.02	2.795	145.64	1.042×10^{-1}	300	1.765*		
61.61	3.280	155.82	1.113	400	1.967		
66.24	3.793	165.95	1.178	500	2.100		
70.92	4.292	175.76	1.238	600	2.204		
75.66	4.790	185.92	1.296	700	2.295		
80.72	5.330	196.02	1.347	800	2.380		
85.20	5.785	206.24	1.400*	900	2.460*		
94.81	6.753	216.34	1.450	1000	2.538		
104.39	7.647	226.17	1.496*	γ 1100	2.614		
114.59	8.576	236.41	1.538				
124.62	9.412	245.95	1.575*				
138.68	1.050×10^{-1}	256.38	1.616				
146.69	1.106	266.21	1.653*				
155.86	1.166	276.10	1.687				
165.96	1.231	286.70	1.722*				
175.94	1.288	296.22	1.757*				
185.93	1.344	298.15	1.760				
195.92	1.394						
206.22	1.441						
216.22	1.490*						
236.42	1.532						
236.16	1.571*						
245.79	1.611						
256.19	1.649*						
266.31	1.686						
276.22	1.717*						
286.41	1.752						
296.48	1.778*						
298.16	1.785						
CURVE 2							
54.15	2.228×10^{-1}	135.85	1.784×10^{-4}				
58.76	2.650	300	1.790*				
63.28	3.080	400	2.023				
67.99	3.544	500	2.162				
72.82	4.021	600	2.263				
77.35	4.459	700	2.346				
82.42	4.963	900	2.488				
86.78	5.386	β 970	2.534				
94.74	6.154	α' 970	2.488				
104.93	7.106	1000	2.507*				
114.77	7.971	1100	2.571				
124.82	8.813	1200	2.635				
		1300	2.699				
		1400	2.763				
		1500	2.827				
		1600	2.891				
		1700	2.955*				
		α 1710	2.961				
		α 1710	2.845				
		1750	2.845*				
		1800	2.845				

* Not shown on plot

SPECIFIC HEAT OF
TRICALCIUM SILICON PENTAOXIDE
 Ca_3SiO_5

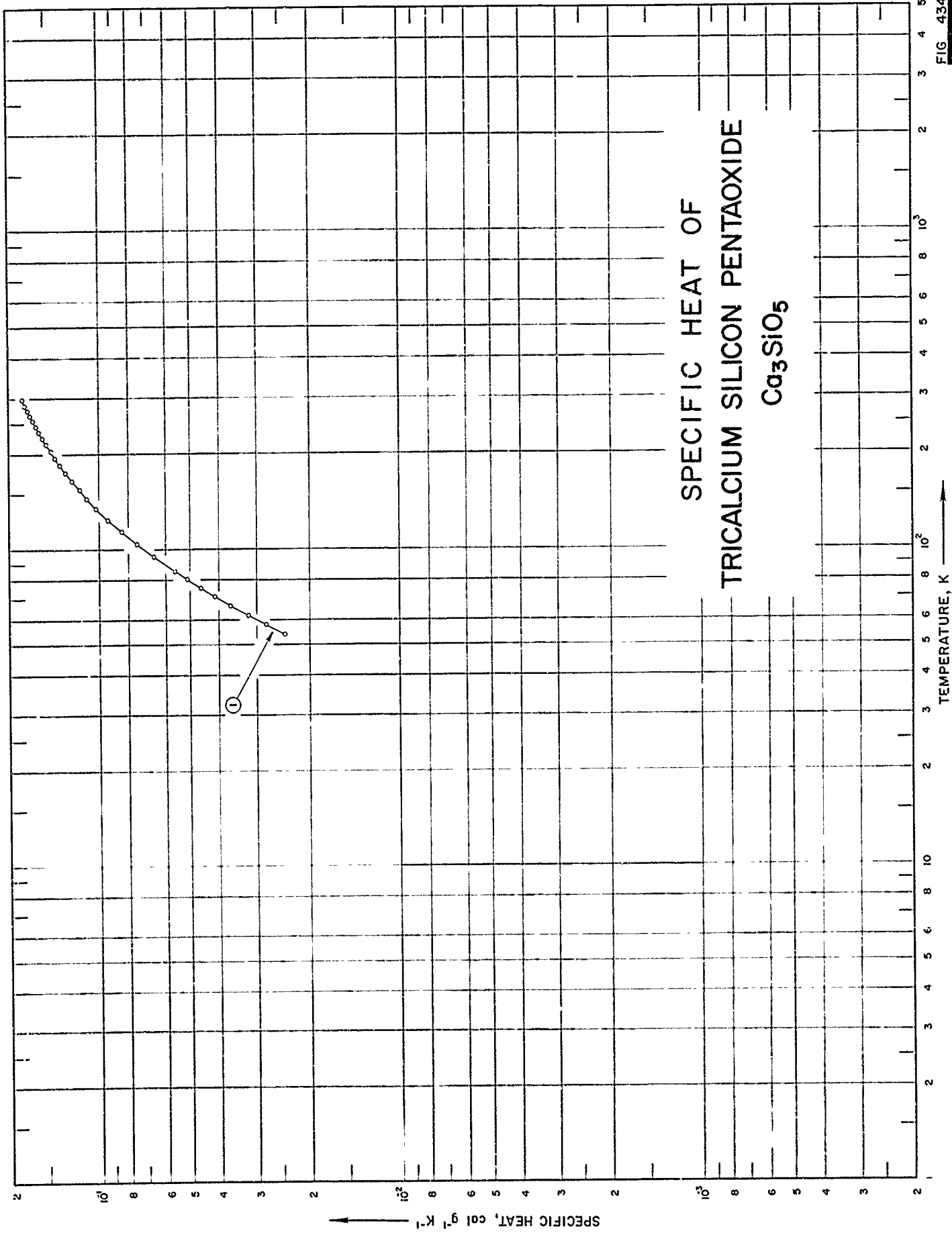

SPECIFICATION TABLE NO. 434 SPECIFIC HEAT OF TRICALCIUM SILICON PENTAOXIDE Ca_3SiO_5

[For Data Reported in Figure and Table No. 434]

Curve No.	Ref. No.	Year	Temp. Range, K	Reported Error, %	Name and Specimen Designation	Composition (weight percent), Specifications and Remarks
1	369	1951	54-298			73.64 CaO, 26.21 SiO_2 (73.69, 26.31 theo.), 0.13 Fe_2O_3 , 0.13 Al_2O_3 , 0.11 MgO, 0.05 ignition loss.

DATA TABLE NO. 434 SPECIFIC HEAT OF TRICALCIUM SILICON PENTAOXIDE, Ca_3SiO_5 T, Temperature, T, K; Specific Heat, C_p , Cal $\text{g}^{-1}\text{K}^{-1}$

T	C_p
	<u>CURVE 1</u>
54.26	2.439×10^{-2}
58.11	2.792
62.13	3.208
66.58	3.674
71.20	4.148
75.83	4.621
80.73	5.142
85.62	5.642
95.10	6.588
104.67	7.499
114.71	8.445
124.74	9.312
136.27	1.025×10^{-1}
146.18	1.102
156.05	1.169
166.07	1.235
176.24	1.297
186.17	1.353
196.00	1.404
206.33	1.453
216.33	1.502
226.01	1.547
236.19	1.587
245.95	1.624
256.33	1.663
266.88	1.698
276.75	1.733
286.50	1.767
296.53	1.791*
298.16	1.799

* Not shown on plot

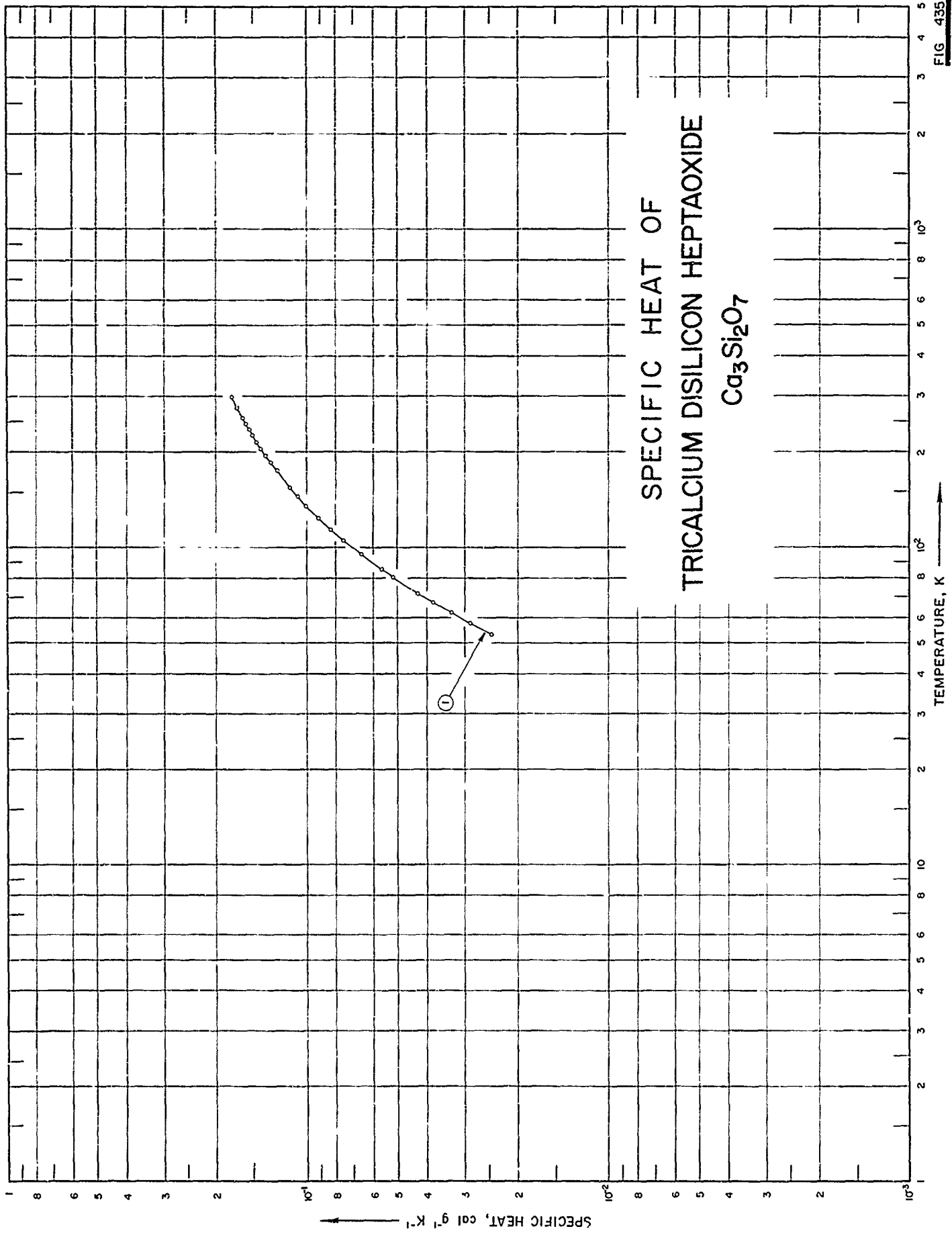

FIG. 435

SPECIFICATION TABLE NO. 435 SPECIFIC HEAT OF TRICALCIUM DISILICON HEPTAOXIDE $\text{Ca}_3\text{Si}_2\text{O}_7$

[For Data Reported in Figure and Table No. 435]

Curve No.	Ref. No.	Year	Temp. Range, K	Reported Error, %	Name and Specimen Designation	Composition (weight percent), Specifications and Remarks
1	370	1957	53-298			58.37 lime, 41.62 silica.

DATA TABLE NO. 435 SPECIFIC HEAT OF TRICALCIUM DISILICON HEPTAOXIDE, $\text{Ca}_3\text{Si}_2\text{O}_7$ [Temperature, T, K; Specific Heat, Cp, Cal $\text{g}^{-1}\text{K}^{-1}$]

T	Cp
	<u>CURVE 1</u>
55.45	2.453×10^{-2}
57.86	2.867
62.42	3.326
67.14	3.810
71.75	4.285
80.68	5.183
85.24	5.631
95.04	6.577
105.04	7.531
114.56	8.328
124.51	9.160
136.28	1.006×10^{-1}
145.77	1.077
155.90	1.146
175.89	1.267
185.89	1.323
195.82	1.374
206.31	1.426
216.22	1.475
226.31	1.518
236.14	1.559
245.95	1.596
256.41	1.642
276.18	1.708
286.69	1.742*
296.15	1.775*
298.15	1.777

* Not shown on plot

FIG. 436

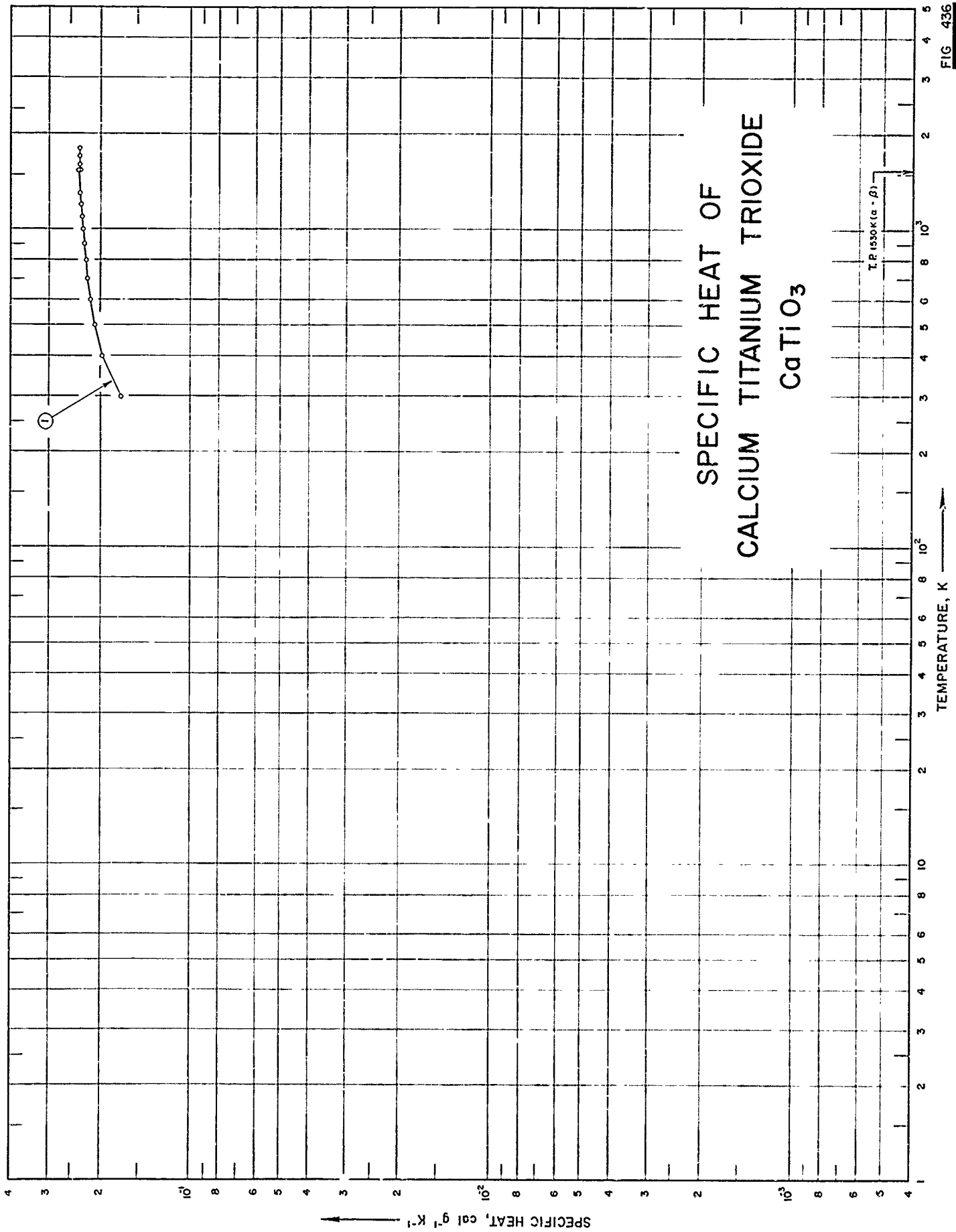

SPECIFICATION TABLE NO. 436 SPECIFIC HEAT OF CALCIUM TITANIUM TRIOXIDE CaTiO_3

[For Data Reported in Figure and Table No. 436]

Curve No.	Ref. No.	Year	Temp. Range, K	Reported Error, %	Name and Specimen Designation	Composition (weight percent), Specifications and Remarks
1	374	1946	298-1800			0.69 CaO acid soluble, 0.05 CO_2 ; $\alpha \rightarrow \beta$ transition at 1530 K.

DATA TABLE NO. 436 SPECIFIC HEAT OF CALCIUM TITANIUM TRIOXIDE, CaTi_2O_6
 [Temperature, T, K; Specific Heat, C_p , Cal $\text{g}^{-1}\text{K}^{-1}$]

T	C_p
<u>CURVE 1</u>	
298	1.717×10^{-1}
300	1.724*
400	1.973
500	2.094
600	2.164
700	2.210
800	2.244
900	2.270
1000	2.292
1100	2.310
1200	2.327
1300	2.342
1500	2.369*
1530	2.373
1550	2.355
1600	2.355
1700	2.355
1800	2.355

* Not shown on plot

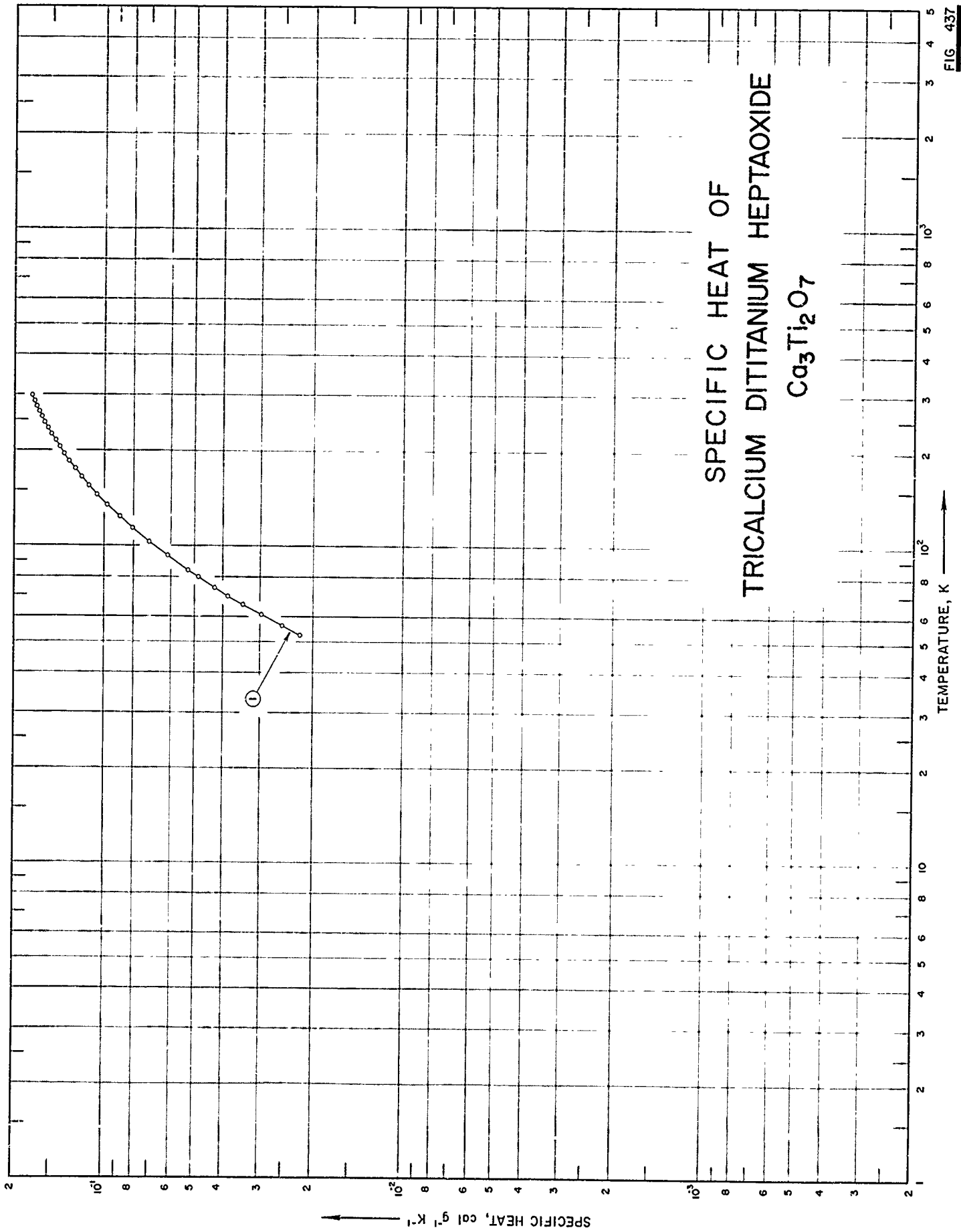

SPECIFICATION TABLE NO. 437 SPECIFIC HEAT OF TRICALCIUM DITITANIUM HEPTAOXIDE $\text{Ca}_3\text{Ti}_2\text{O}_7$

[For Data Reported in Figure and Table No. 437]

Curve No.	Ref. No.	Year	Temp. Range, K	Reported Error, %	Name and Specimen Designation	Composition (weight percent), Specifications and Remarks
1	358	1955	53-298			48.61 titan ^a (48.71 theo.); prepared from reagent-grade calcium carbonate and pure titania; pressed into pellets; heated 5 times for 12 hrs at 1400-1500 C.

DATA TABLE NO. 437 SPECIFIC HEAT OF TRICALCIUM DITITANIUM HEPTAOXIDE, $\text{Ca}_3\text{T}_2\text{O}_7$ [Temperature, T, K; Specific Heat, C_p , Cal $\text{g}^{-1}\text{K}^{-1}$]

T	C_p
<u>CURVE 1</u>	
52.63	2.211×10^{-2}
56.50	2.542
61.10	2.976
65.60	3.426
69.86	3.844
74.28	4.262
80.15	4.838
84.36	5.249
88.53	6.130
103.69	7.072
114.31	8.041
124.38	8.898
135.58	9.795
146.01	1.060×10^{-1}
155.76	1.129
165.69	1.194
176.52	1.258
186.67	1.319
196.44	1.368
206.18	1.418
216.18	1.466
226.70	1.510
236.29	1.559
245.74	1.584
256.21	1.620
266.17	1.650
276.05	1.683
286.53	1.711
296.87	1.738*
298.16	1.744

* Not shown on plot

SPECIFIC HEAT OF
CALCIUM TUNGSTEN TETRAOXIDE
CaWO₄

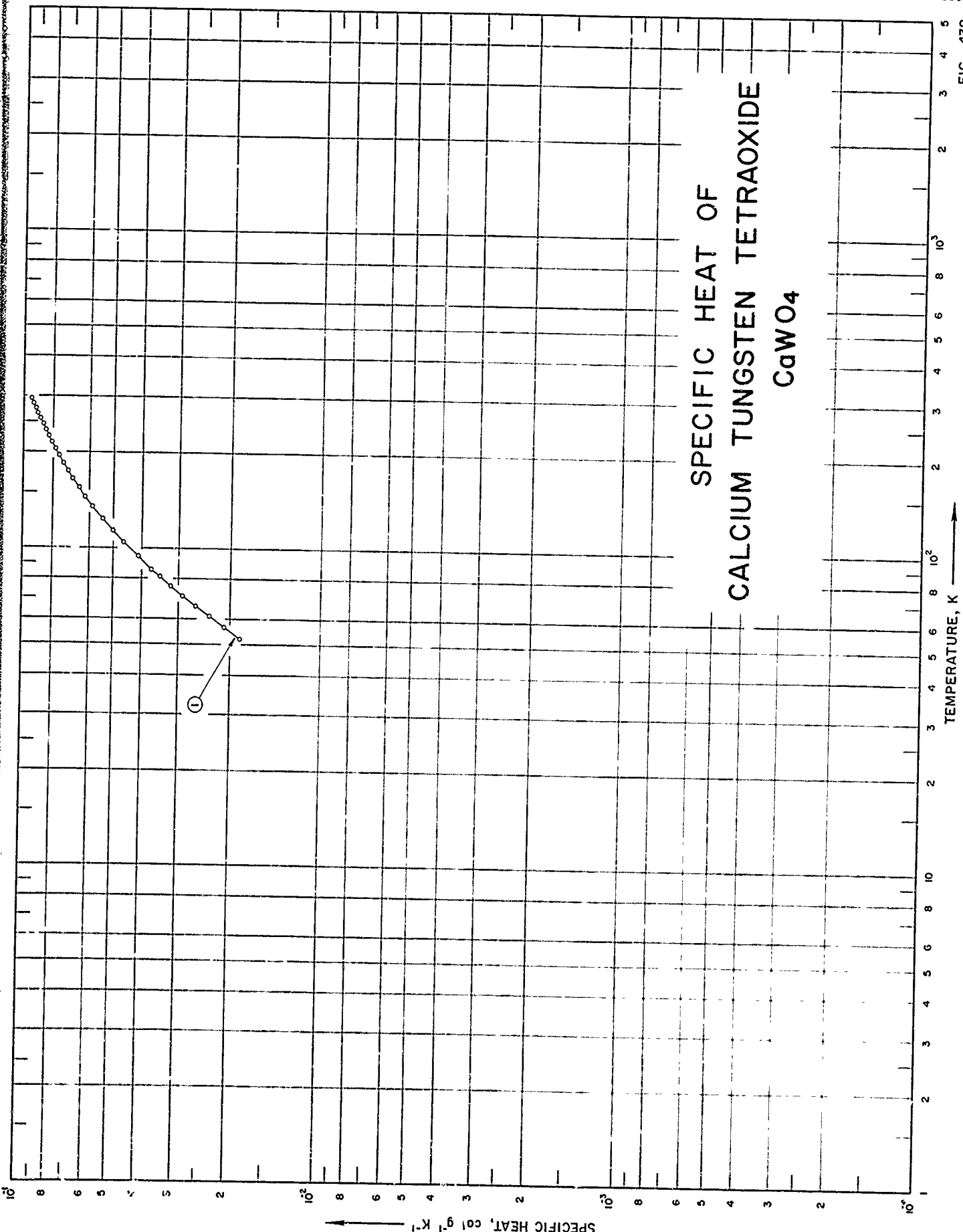

SPECIFICATION TABLE NO. 438 SPECIFIC HEAT OF CALCIUM TUNGSTEN TETRAOXIDE CaWO_4

† For Data Reported in Figure and Table No. 438

Curve No.	Ref. No.	Year	Temp. Range, K	Reported Error, %	Name and Specimen Designation	Composition (weight percent)	Specifications and Remarks
1	375	1961	52-296	0.3		80.59 WO_6 , 19.49 CaO , prepared by heating stoichiometric mixture of reagent-grade calcium carbonate and tungstic acid 7 times for total of 2 days at 680 C and 10 days at 800 C.	

DATA TABLE NO. 133 SPECIFIC HEAT OF CALCIUM TUNGSTEN TETRAOXIDE, CaWO₄
 Temperature, T, K; Specific Heat, C_p, Cal g⁻¹K⁻¹

T	C _p
<u>CURVE 1</u>	
52.28	1.866 x 10 ⁻²
56.82	2.103
61.52	2.366
66.15	2.627
71.26	2.910
76.41	3.186
81.75	3.467
86.45	3.707
94.79	4.106
104.82	4.607
114.15	5.010
124.37	5.447
136.44	5.889
145.88	6.226
155.88	6.549
166.32	6.865
178.19	7.143
186.36	7.396
196.26	7.626
206.26	7.855
216.56	8.077
226.18	8.275
236.06	8.477
246.04	8.647
256.57	8.842
266.46	9.012
276.99	9.158
286.96	9.318
296.40	9.474
<u>CURVE 2</u>	
294	1.031 x 10 ⁻¹
300	1.034
400	1.072
500	1.110
600	1.148
700	1.186
800	1.224
900	1.262
1000	1.300
1073	1.328

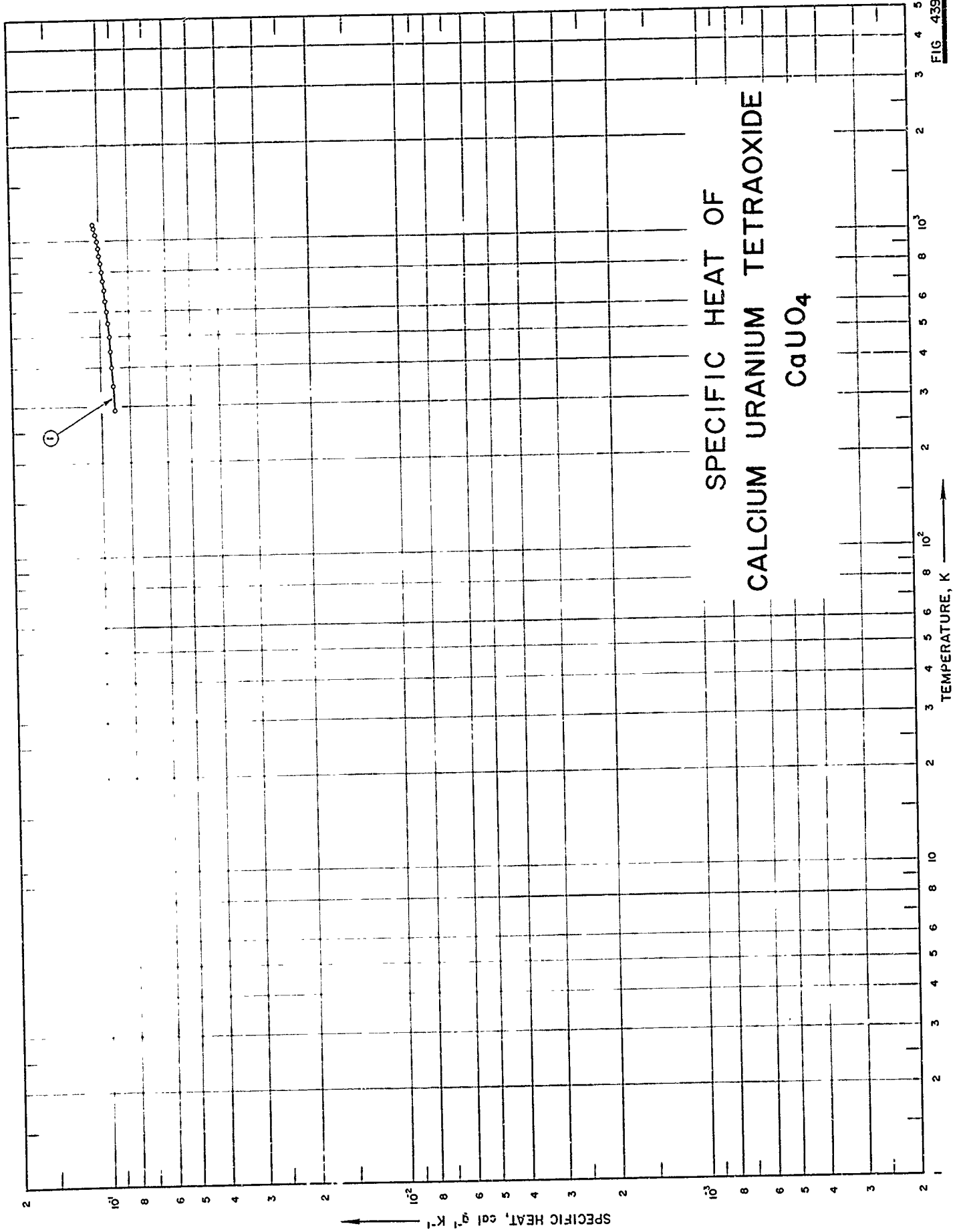

FIG 439

SPECIFICATION TABLE NO. 439 SPECIFIC HEAT OF CALCIUM URANIUM TETRAOXIDE CaUO_4

[For Data Reported in Figure and Table No. 439]

Curve No.	Ref. No.	Year	Temp. Range, K	Reported Error, %	Name and Specimen Designation	Composition (weight percent), Specifications and Remarks
1	376	1960	293-1134	0.1		69.40 U; 11.41 Ca.

DATA TABLE NO. 439 SPECIFIC HEAT OF CALCIUM URANIUM TETRAOXIDE, CaUO_4
 [Temperature, T, K; Specific Heat, C_p , Cal $\text{g}^{-1}\text{K}^{-1}$]

T	C_p
	<u>CURVE 1</u>
293	9.034×10^{-2}
300	9.046
350	9.128
400	9.209
450	9.291
500	9.373
550	9.455
600	9.537
650	9.618
700	9.700
750	9.782
800	9.864
850	9.946
900	1.003×10^{-1}
950	1.011
1000	1.019
1025	1.023
1025	1.032
1050	1.037
1100	1.046
1134	1.052

SPECIFIC HEAT OF CALCIUM DIVANADIUM HEXAOXIDE CaV2O6

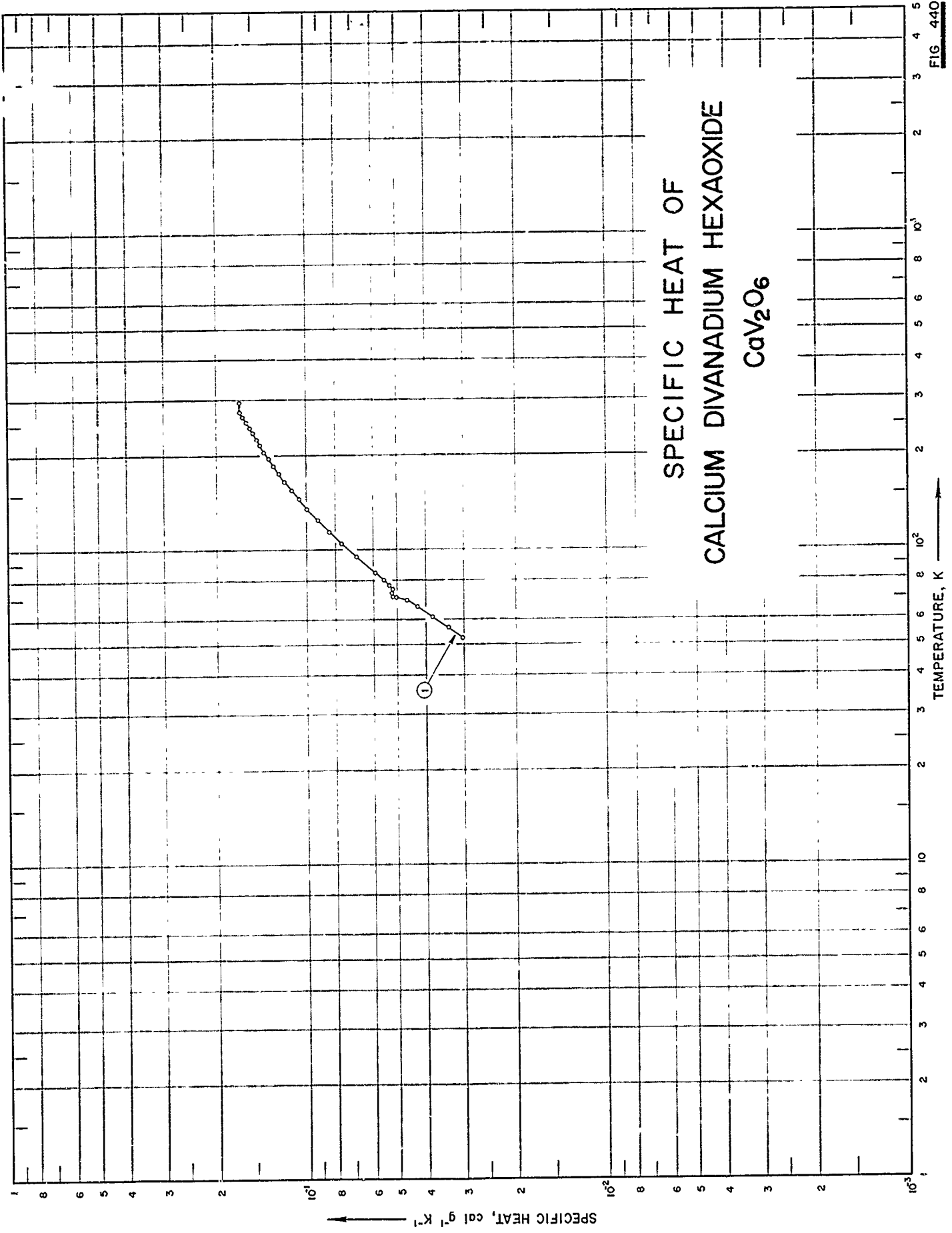

SPECIFICATION TABLE NO. 440 SPECIFIC HEAT OF CALCIUM DIVANADIUM HEXAOXIDE CaV_2O_6

[For Data Reported in Figure and Table No. 440]

Curve No.	Ref. No.	Year	Temp. Range, K	Reported Error, %	Name and Specimen Designation	Composition (weight percent), Specifications and Remarks
1	378	1961	53-296	0.30		76.32 V_2O_5 , 23.48 CaO ; prepared by heating stoichiometric mixture of reagent-grade calcium carbonate and vanadium pentaoxide at 610-660 C for 17 days.

DATA TABLE NO. 440 SPECIFIC HEAT OF CALCIUM DIVANADIUM HEXAOXIDE, CaV_2O_6
 [Temperature, T, K; Specific Heat, C_p , Cal $\text{g}^{-1}\text{K}^{-1}$]

T	C_p
CURVE 1	
52.26	3.028×10^{-2}
52.72	8.037*
56.63	3.378
61.31	3.819
61.35	3.818*
66.12	4.286
69.23	4.647
70.64	5.038
71.43	5.194
73.29	5.206
75.15	5.190
75.19	5.240*
77.15	5.337
80.15	5.547
84.59	5.937
95.02	6.841
105.19	7.686
114.60	8.417
124.62	9.165
135.98	9.955
145.73	1.061×10^{-1}
155.83	1.12*
166.00	1.181
176.23	1.234
186.28	1.288
196.19	1.333
204.70	1.382
216.39	1.425
226.14	1.466
236.17	1.506
245.76	1.543
256.39	1.584
266.20	1.624
266.40	1.624*
270.03	1.638*
273.84	1.650*
275.17	1.658*
276.39	1.667
277.23	1.672*
279.17	1.675*
381.07	1.662*
283.14	1.651*
286.38	1.648*
286.66	1.650*
295.91	1.667*
295.93	1.670

* Not shown on plot

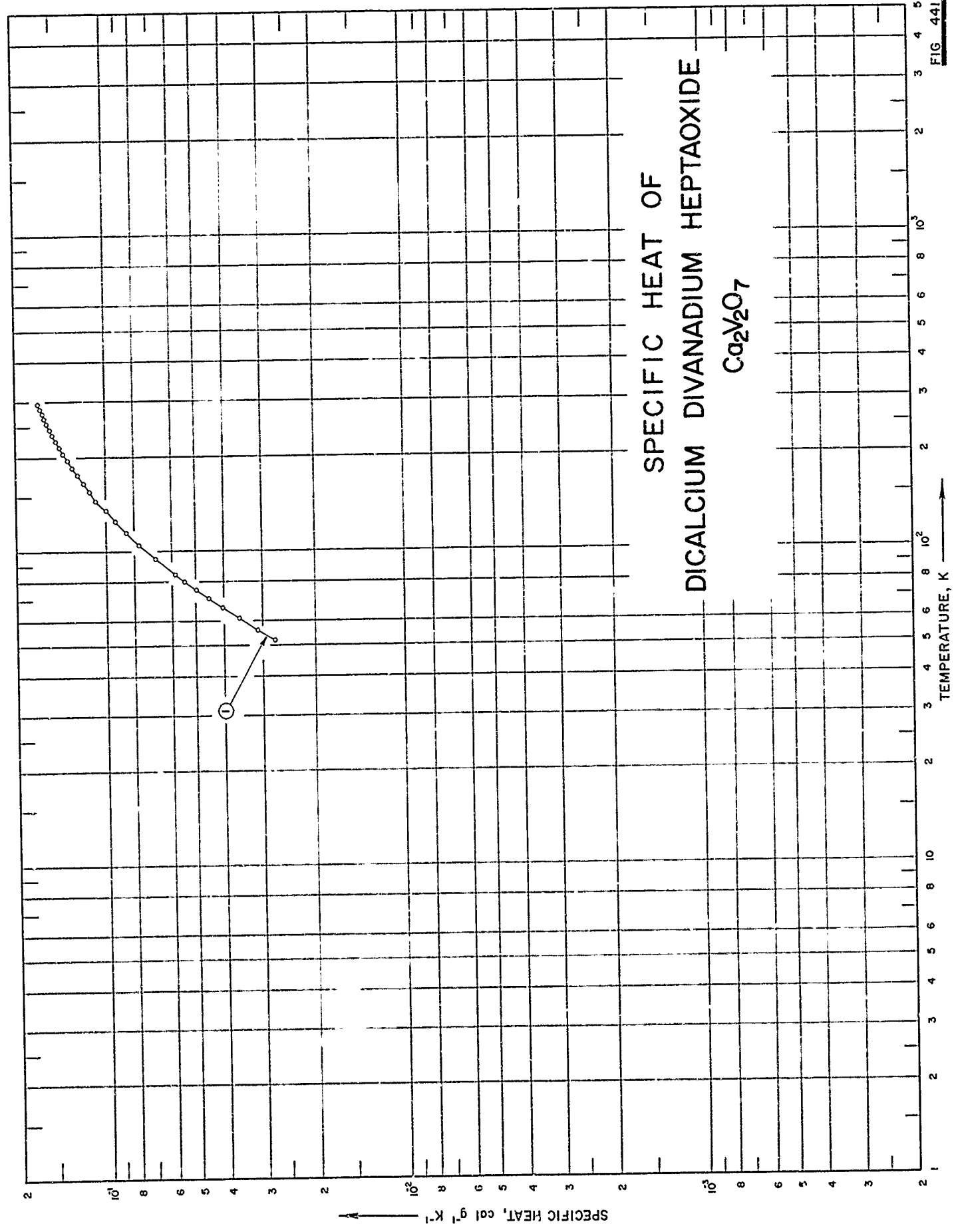

FIG 441

SPECIFICATION TABLE NO. 441 SPECIFIC HEAT OF DICALCIUM DIVANADIUM HEPTAOXIDE $\text{Ca}_2\text{V}_2\text{O}_7$

[For Data Reported in Figure and Table No. 441]

Curve No.	Ref. No.	Year	Temp. Range, K	Reported Error, %	Name and Specimen Designation	Composition (weight percent), Specifications and Remarks
1	378	1961	52-296	0.3		61.78 V_2O_5 , 38.08 CaO ; prepared by heating stoichiometric mixture of the oxides at 600-670 C for 28 hrs.

DATA TABLE NO. 441 SPECIFIC HEAT OF DICALCIUM DIVANADIUM HEPTAOXIDE, $\text{Ca}_2\text{V}_2\text{O}_7$ [Temperature, T, K; Specific Heat, C_p , Cal $\text{g}^{-1}\text{K}^{-1}$]

T	C_p
52.14	2.763×10^{-2}
56.28	3.150
61.23	3.639
66.12	4.125
70.83	4.594
75.45	5.047
80.22	5.512
84.52	5.921
94.69	6.856
105.59	7.808
115.09	8.576
125.18	9.348
136.31	1.013×10^{-1}
145.97	1.080
155.91	1.141
165.87	1.197
176.43	1.254
186.14	1.302
196.26	1.346
206.27	1.391
216.48	1.436
226.20	1.474
236.39	1.512
245.95	1.544
256.62	1.580
266.17	1.612
276.14	1.639
286.71	1.669
296.03	1.697

SPECIFIC HEAT OF
TRICALCIUM DIVANADIUM OCTAOXIDE
 $Ca_3V_2O_8$

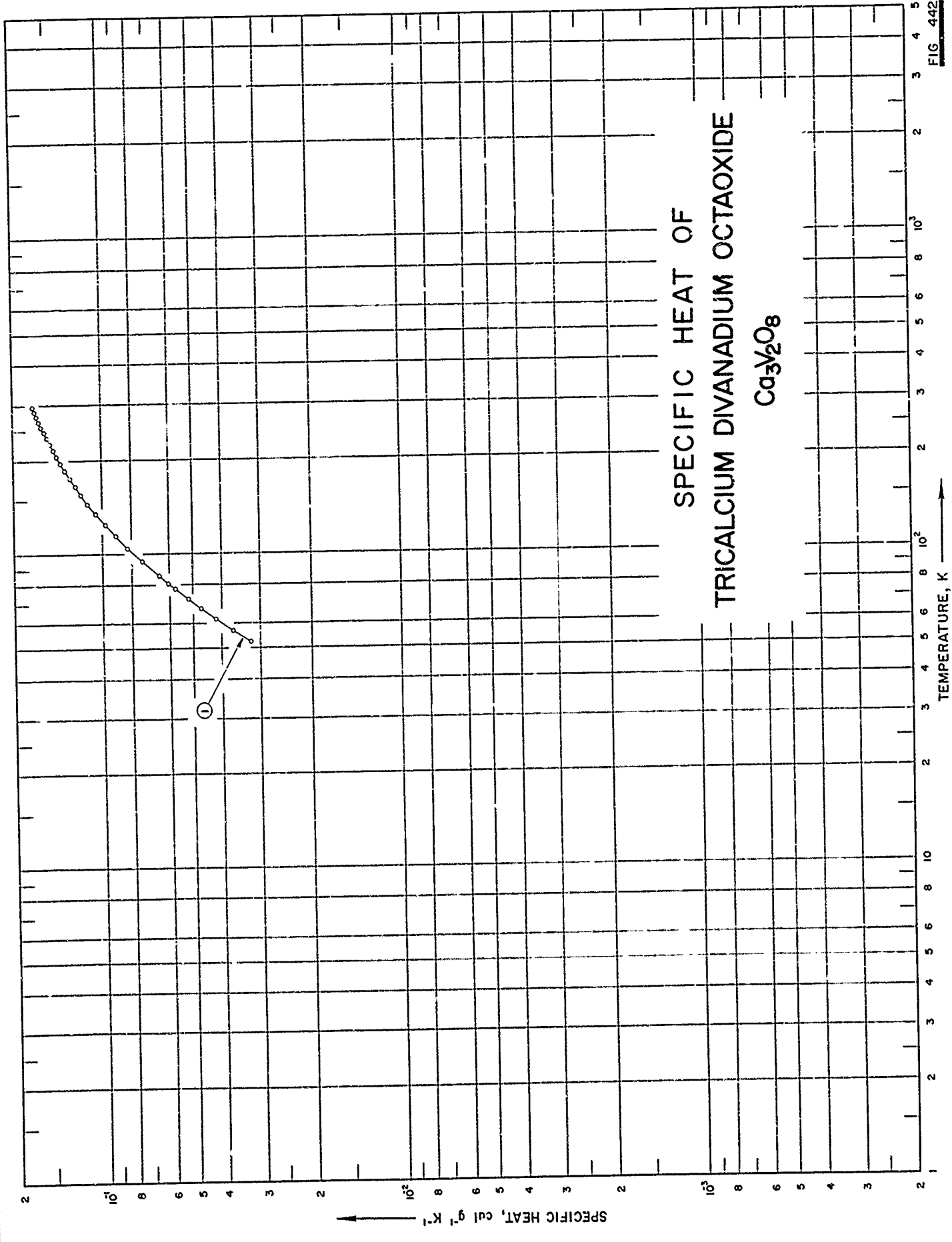

SPECIFICATION TABLE NO. 442 SPECIFIC HEAT OF TRICALCIUM DIVANADIUM OCTAOXIDE $\text{Ca}_3\text{V}_2\text{O}_8$

[For Data Reported in Figure and Table No. 442]

Curve No.	Ref. No.	Year	Temp. Range, K	Reported Error, %	Name and Specimen Designation	Composition (weight percent), Specifications and Remarks
1	378	1961	53-297	0.3		52.00 V_2O_5 , 48.01 CaO; prepared by heating stoichiometric oxide mixture at 400 C for 3700 hrs and 1000 C for 16 hrs.

DATA TABLE NO. 442 SPECIFIC HEAT OF TRICALCIUM DIVANADIUM OCTAOXIDE, $\text{Ca}_3\text{V}_2\text{O}_8$ [Temperature, T, K; Specific Heat, C_p , Cal $\text{g}^{-1}\text{K}^{-1}$]

T	C_p
	<u>CURVE 1</u>
52.73	3.283×10^{-2}
57.43	3.696
62.35	4.210
67.27	4.721
72.20	5.226
77.64	5.766
80.60	6.052
85.60	6.537
95.16	7.411
105.03	8.274
115.11	9.079
124.98	9.830
136.31	1.062×10^{-1}
145.98	1.176
156.06	1.186
166.12	1.240
176.49	1.293
186.70	1.343
196.36	1.384
206.50	1.428
216.40	1.466
226.26	1.503
236.40	1.541
245.91	1.569
256.64	1.605
267.36	1.637
276.93	1.662
287.46	1.695
296.68	1.717

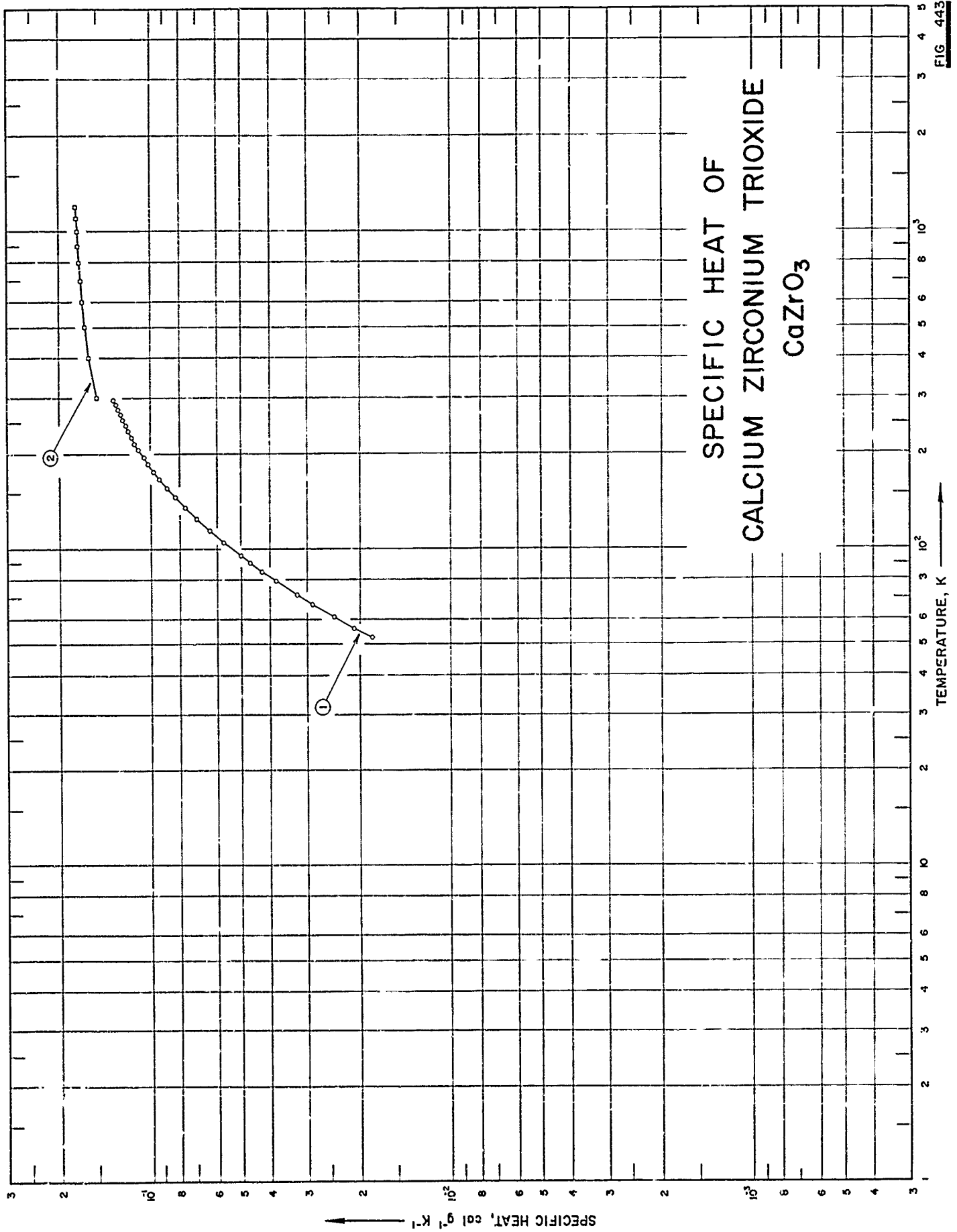

FIG. 443

SPECIFICATION TABLE NO. 443 SPECIFIC HEAT OF CALCIUM ZIRCONIUM TRIOXIDE CaZrO_3

[For Data Reported in Figure and Table No. 443]

Curve No.	Ref. No.	Year	Temp. Range, K	Reported Error, %	Name and Specimen Designation	Composition (weight percent), Specifications and Remarks
1	364	1960	53-296	0.3		68.67 ZrO_2 , 31.19 CaO ; prepared by heating intimate mixture of reagent-grade calcium carbonate and pure zirconia for 30 hrs between 1200 and 1300 C and for 32 hrs between 1400 and 1500 C.
2	54	1965	300-1200	0.8		Sample supplied by Norton Co.

DATA TABLE NO. 443 SPECIFIC HEAT OF CALCIUM ZIRCONIUM TRIOXIDE, CaZrO_3
 [Temperature, T, K; Specific Heat, C_p , Cal $\text{g}^{-1}\text{K}^{-1}$]

T	C_p
<u>CURVE 1</u>	
52.81	1.837×10^{-2}
56.46	2.100
61.13	2.451
66.91	2.896
71.72	3.263
79.36	3.847
84.90	4.262
90.48	4.670
95.27	5.020
105.15	5.728
114.53	6.352
124.95	7.016
135.78	7.685
145.94	8.277
155.91	8.823
167.20	9.353
176.76	9.777
186.48	1.020×10^{-1}
196.11	1.056
207.43	1.098
216.25	1.127
225.94	1.159
236.04	1.189
245.67	1.212
256.68	1.243
266.35	1.264
276.29	1.286
287.01	1.311
296.10	1.327
<u>CURVE 2</u>	
300	1.503×10^{-1}
400	1.604
500	1.655
600	1.685
700	1.707
800	1.723
900	1.736
1000	1.747
1100	1.757
1200	1.767

SPECIFIC HEAT OF
DICALCIUM DIALUMINUM SILICON
HEPTAOXIDE $\text{Ca}_2\text{Al}_2\text{SiO}_7$

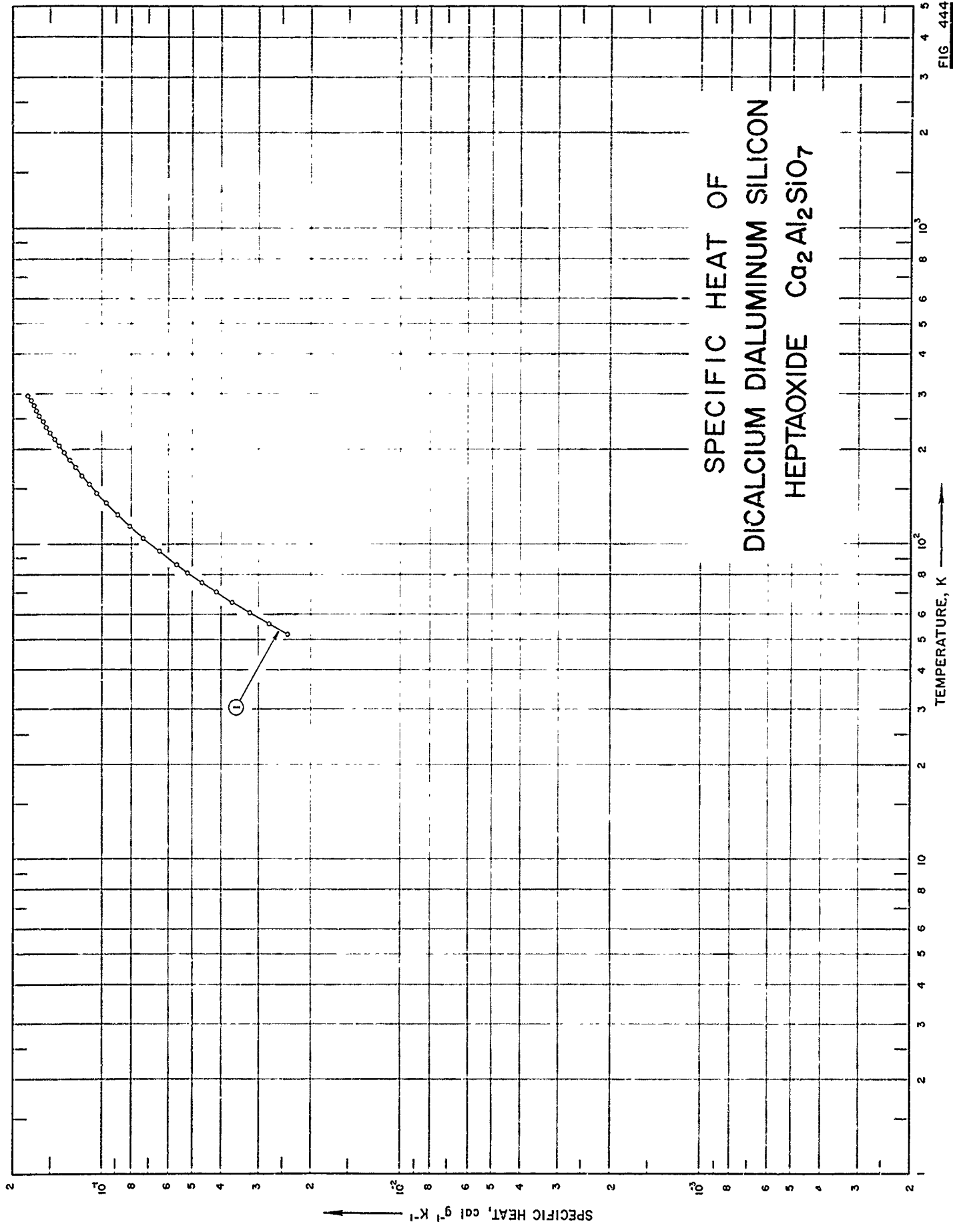

SPECIFICATION TABLE NO. 444 SPECIFIC HEAT OF DICALCIUM DIALUMINUM SILICON HEPTAOXIDE $\text{Ca}_2\text{Al}_2\text{SiO}_7$

[For Data Reported in Figure and Table No. 444]

Curve No.	Ref. No.	Year	Temp. Range, K	Reported Error, %	Name and Specimen Designation	Composition (weight percent), Specifications and Remarks
1	379	1963	52-296	0.30	Gehlenite	40.92 CaO, 37.25 Al_2O_3 , 21.86 SiO_2 ; prepared from reagent-grade calcium carbonate, alumina, and silica by heating stoichiometric mixture for 175 hrs at 1050 C, 205 hrs at 1150 C, and 20 hrs at 1300 C.

DATA TABLE NO. 444 SPECIFIC HEAT OF DICALCIUM DIALUMINUM SILICON HEPTAOXIDE, $\text{Ca}_2\text{Al}_2\text{SiO}_7$
 Temperature, T, K; Specific Heat, C_p , Cal $\text{g}^{-1}\text{K}^{-1}$

T	C_p
<u>CURVE 1</u>	
52.14	2.403×10^{-2}
56.17	2.773
60.74	3.228
65.64	3.698
70.57	4.161
75.68	4.661
81.48	5.204
86.39	5.660
95.18	6.459
105.00	7.316
114.56	8.115
124.64	8.917
135.31	9.752
146.53	1.052×10^{-1}
155.65	1.112
165.79	1.176
175.90	1.239
185.88	1.295
196.05	1.350
206.17	1.403
216.37	1.454
226.11	1.503
236.69	1.552
245.80	1.589
256.17	1.634
266.41	1.674
276.63	1.713
286.80	1.749
296.23	1.783

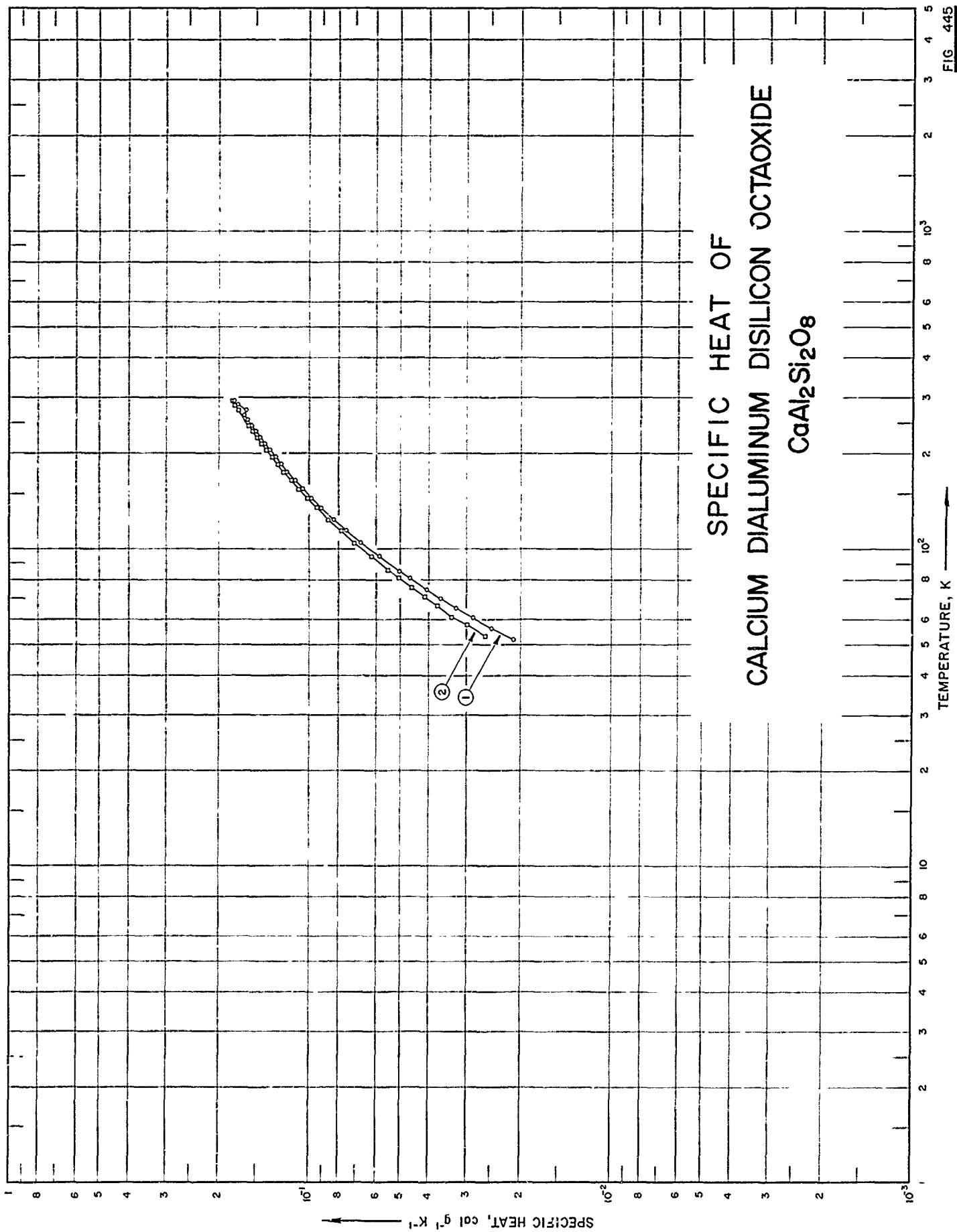

FIG. 445

SPECIFICATION TABLE NO. 445 SPECIFIC HEAT OF CALCIUM DIALUMINUM DISILICON OCTAOXIDE $\text{CaAl}_2\text{Si}_2\text{O}_8$

[For Data Reported in Figure and Table No. 445]

Curve No.	Ref. No.	Year	Temp. Range, K	Reported Error, %	Name and Specimen Designation	Composition (weight percent)	Specifications and Remarks
1	380	1961	52-296		Hexagonal anorthite	42.99 SiO_2 , 34.84 Al_2O_3 , 19.77 CaO , 1.76 Fe_2O_3 , 0.33 TiO_2 , 0.17 H_2O , 0.16 K_2O , 0.15 FeO , 0.07 Na_2O , 0.03 MgO , 0.01 Mg_2O ; heated at 600 C for 48 hrs;	
2	370	1957	53-296		Anorthite	43.02 SiO_2 , 36.64 Al_2O_3 , 20.10 CaO , 0.20 Fe_2O_3 .	

DATA TABLE NO. 445 SPECIFIC HEAT OF CALCIUM DIALUMINUM DISILICON OCTAOXIDE, $\text{CaAl}_2\text{Si}_2\text{O}_8$ [Temperature, T, K; Specific Heat, Cp, Cal $\text{g}^{-1}\text{K}^{-1}$]

T	Cp	
	CURVE 1	CURVE 2 (cont.)
52.28	2.111×10^{-2}	145.47
56.53	2.481	155.60
60.96	2.863	165.80
65.44	3.264	175.97
69.93	3.666	185.90
74.63	4.083	195.83
81.05	4.647	206.17
85.43	5.028	215.93
94.86	5.851	226.04
105.69	6.754	235.89
115.27	7.530	245.73
124.82	8.270	256.12
135.88	9.101	266.09
145.46	9.816	276.13
155.82	1.052×10^{-1}	286.47
165.15	1.119	295.93
176.21	1.182	
186.29	1.244	
196.16	1.298	
206.18	1.353	
216.20	1.410	
226.30	1.464	
236.15	1.513	
245.93	1.560	
256.73	1.612	
266.43	1.655	
276.52	1.627	
286.56	1.741	
296.06	1.782	

CURVE 2

T	Cp
53.43	2.611×10^{-2}
57.86	2.998
61.14	3.376
66.41	3.756
70.92	4.144
75.70	4.576
81.13	5.046
85.78	5.470
94.74	6.218
105.23	7.081
114.84	7.832
124.75	8.601
136.11	9.446

* Not shown on plot

SPECIFIC HEAT OF
CALCIUM DIALUMINUM DISILICON
OCTAOXIDE DIHYDRATE
 $\text{CaAl}_2\text{Si}_2\text{O}_8 \cdot 2\text{H}_2\text{O}$

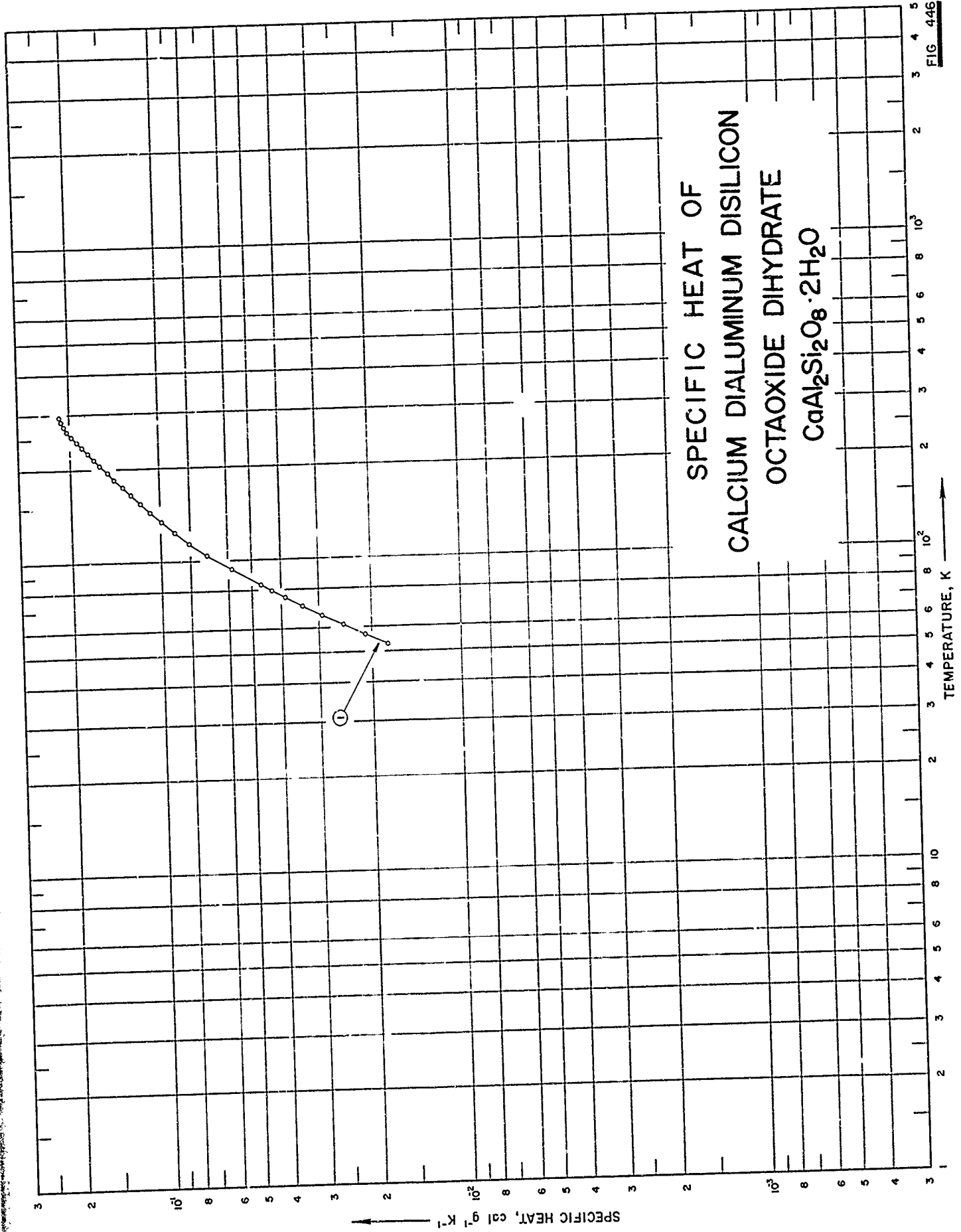

SPECIFICATION TABLE NO. 446 SPECIFIC HEAT OF CALCIUM DIALUMINUM DISILICON OCTAOXIDE DIHYDRATE $\text{CaAl}_2\text{Si}_2\text{O}_8 \cdot 2\text{H}_2\text{O}$

[For Data Reported in Figure and Table No. 446]

Curve No.	Ref. No.	Year	Temp. Range, K	Reported Error, %	Name and Specimen Designation	Composition (weight percent), Specifications and Remarks
1	380	1961	53-296		Lawsonte	38.14 SiO_2 , 30.91 Al_2O_3 , 17.54 CaO , 11.49 H_2O , 1.56 Fe_2O_3 , 0.29 TiO_2 , 0.14 K_2O , 0.13 FeO , 0.06 Na_2O , 0.03 MgO , 0.01 Mg_2O .

DATA TABLE NO. 446 SPECIFIC HEAT OF CALCIUM DIALUMINUM DISILICON OCTAOXIDE DIHYDRATE, $\text{CaAl}_2\text{Si}_2\text{O}_8 \cdot 2\text{H}_2\text{O}$ Temperature, T, K; Specific Heat, C_p , Cal $\text{g}^{-1}\text{K}^{-1}$

T	C_p
	<u>CURVE 1</u>
53.04	1.774×10^{-2}
57.20	2.112
61.50	2.497
66.15	2.935
70.97	3.402
75.67	3.876
79.88	4.309
83.57	4.687
94.38	5.858
105.44	7.080
114.97	8.086
124.78	9.012
135.90	9.995
145.63	1.084×10^{-1}
155.67	1.173
166.04	1.264
175.92	1.349
185.96	1.435
196.15	1.517
206.46	1.597
216.26	1.674
226.34	1.750
236.04	1.827
245.74	1.899
245.82	1.897*
255.96	1.973
256.31	1.979*
265.85	2.051
269.05	2.066*
271.97	2.082*
275.95	2.095
286.19	2.131
286.44	2.126*
296.09	2.163*
296.13	2.162

* Not shown on plot

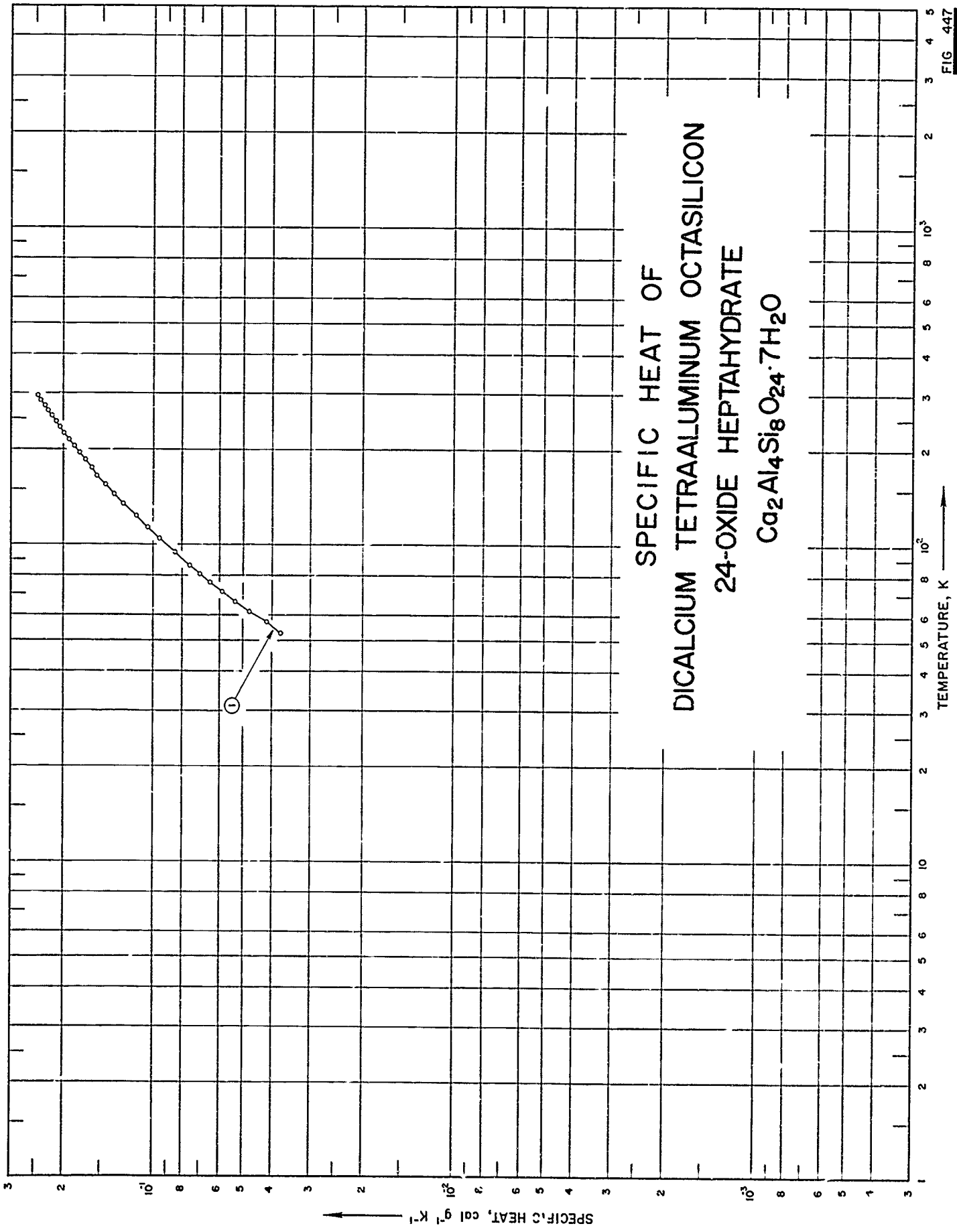

FIG. 447

SPECIFICATION TABLE NO. 447 SPECIFIC HEAT OF DICALCIUM TETRAALUMINUM OCTASILICON 24-OXIDE HEPTAHYDRATE $\text{Ca}_2\text{Al}_4\text{Si}_8\text{O}_{24} \cdot 7\text{H}_2\text{O}$

[For Data Reported in Figure and Table No. 447]

Curve No.	Ref. No.	Year	Temp. Range, K	Reported Error, %	Name and Specimen Designation	Composition (weight percent), Specifications and Remarks
1	380	1961	53-296		Leonhardtite	51.30 SiO_2 , 22.68 Al_2O_3 , 13.67 H_2O , 11.43 CaO , 0.18 FeO , 0.15 K_2O , 0.14 Na_2O , 0.09 SrO ; air dried to remove 1 mole loosely-bound water.

DATA TABLE NO. 447 SPECIFIC HEAT OF DICALCIUM TETRAALUMINUM OCTASILICON 24-OXIDE HEPTAHYDRATE, $\text{Ca}_2\text{Al}_4\text{O}_{21} \cdot 7\text{H}_2\text{O}$ [Temperature, T, K; Specific Heat, C_p , Cal $\text{g}^{-1}\text{K}^{-1}$]

T	C_p
	<u>CURVE 1</u>
52.88	3.779×10^{-2}
57.29	4.206
61.85	4.820
66.46	5.363
71.45	5.944
76.46	6.511
81.29	7.048
86.31	7.601
94.99	8.527
105.21	9.611
114.47	1.053×10^{-1}
124.80	1.158
136.35	1.271
145.79	1.363
155.91	1.454
165.98	1.562
175.86	1.622
185.91	1.702
196.11	1.780
206.57	1.861
216.67	1.937
226.29	2.014
236.13	2.073
245.87	2.136
256.53	2.205
266.47	2.270
276.40	2.330
286.76	2.400
296.42	2.460

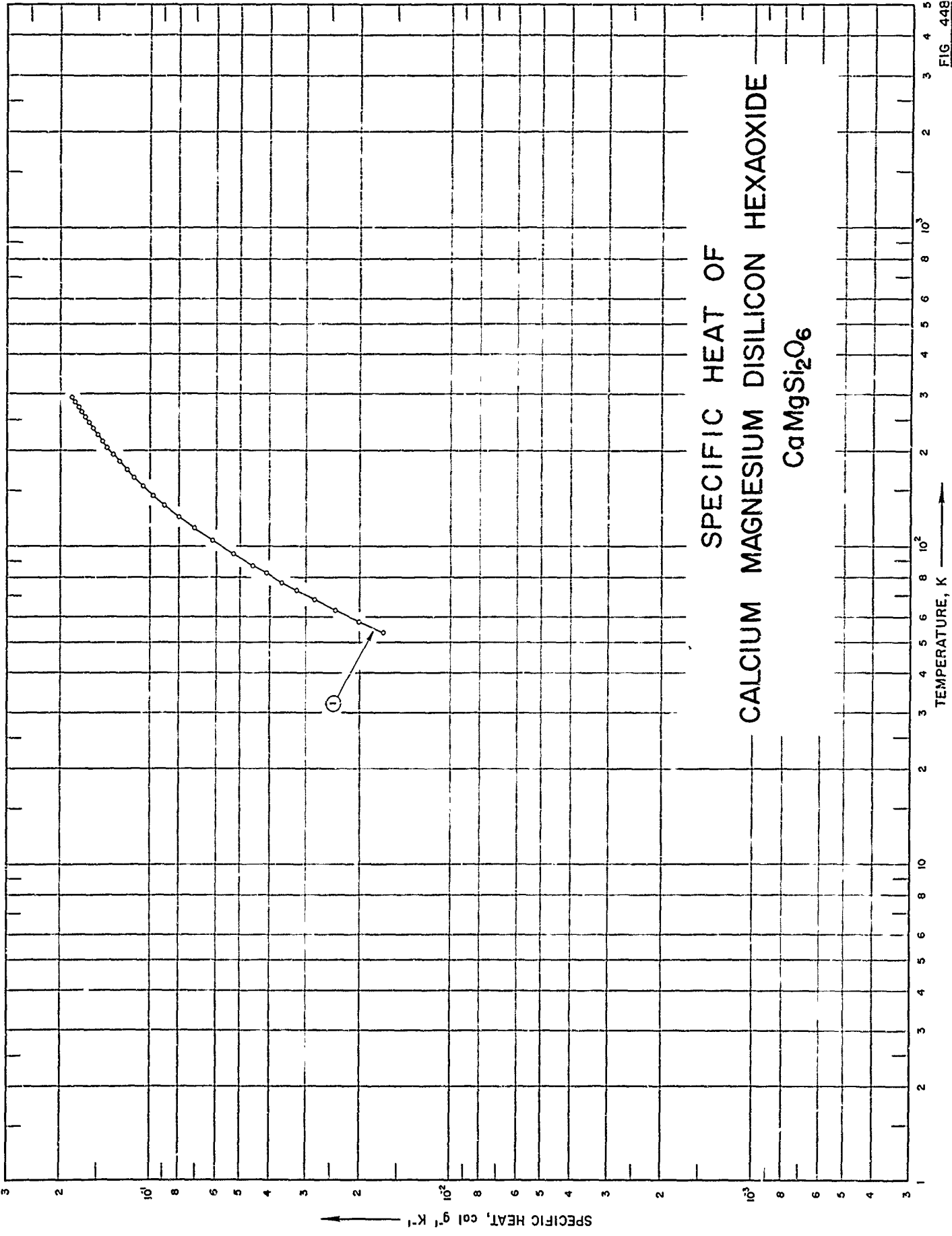

SPECIFICATION TABLE NO. 448 SPECIFIC HEAT OF CALCIUM MAGNESIUM DISILICON HEXAOXIDE $\text{CaMgSi}_2\text{O}_6$

[For Data Reported in Figure and Table No. 448]

Curve No.	Ref. No.	Year	Temp. Range, K	Reported Error, %	Name and Specimen Designation	Composition (weight percent), Specifications and Remarks
1	370	1957	54-296			54.78 SiO_2 , 25.91 CaO, 18.82 MgO, 0.68 Fe_2O_3 , 0.07 FeO.

DATA TABLE NO. 448 SPECIFIC HEAT OF CALCIUM MAGNESIUM DISILICON HEXAOXIDE, $\text{CaMgSi}_2\text{O}_6$ [Temperature, T, K; Specific Heat, C_p , Cal $\text{g}^{-1}\text{K}^{-1}$]

T	C_p
53.83	1.671×10^{-2}
58.40	2.021
63.33	2.416
68.23	2.835
72.87	3.242
77.47	3.656
82.52	4.119
87.18	4.550
94.82	5.268
105.11	6.238
114.71	7.120
124.66	8.020
135.80	8.985
145.58	9.812
155.87	1.062×10^{-1}
165.78	1.135
175.86	1.206
186.01	1.274
195.86	1.337
206.24	1.401
216.42	1.458
226.05	1.511
235.88	1.562
245.64	1.608
256.29	1.660
266.14	1.704
276.08	1.748
286.63	1.790
295.98	1.831

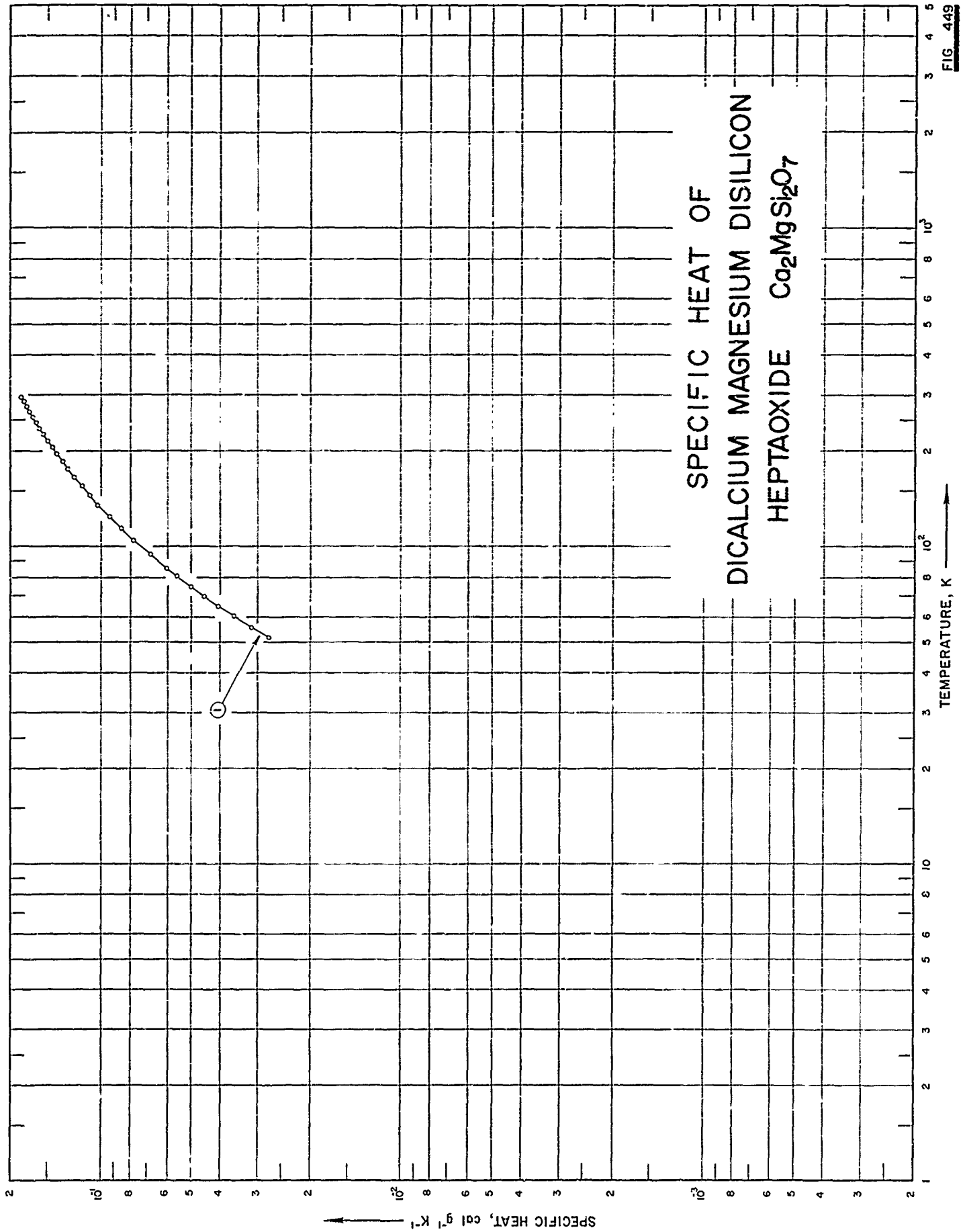

FIG. 449

SPECIFICATION TABLE NO. 449 SPECIFIC HEAT OF DICALCIUM MAGNESIUM DISILICON HEPTAOXIDE $\text{Ca}_2\text{MgSi}_2\text{O}_7$

[For Data Reported in Figure and Table No. 449]

Curve No.	Ref. No.	Year	Temp. Range, K	Reported Error, %	Name and Specimen Designation	Composition (weight percent), Specifications and Remarks
1	379	1963	52-296	0.3	Akermanite	44.14 SiO_2 , 41.16 CaO, 14.82 MgO; synthesized by heating stoichiometric mixture of reagent-grade calcium carbonate, magnesium oxide, and silica for 45 hrs at 1050 C, 115 hrs at 1150 C, and 30 hrs at 1250 C.

DATA TABLE NO. 449 SPECIFIC HEAT OF DICALCIUM MAGNESIUM DISILICON HEPTAOXIDE, $\text{Ca}_2\text{MgSi}_2\text{O}_7$ [Temperature, T, K; Specific Heat, C_p , Cal $\text{g}^{-1}\text{K}^{-1}$]

T	C_p
<u>CURVE 1</u>	
51.93	2.769×10^{-2}
55.97	3.154
60.46	3.620
65.06	4.079
69.85	4.541
74.85	5.036
80.65	5.593
85.44	6.048
94.60	6.866
105.51	7.820
114.74	8.590
124.65	9.393
135.89	1.026×10^{-1}
145.66	1.095
155.74	1.164
165.73	1.227
176.06	1.290
186.10	1.348
195.97	1.403
206.31	1.458
216.26	1.510
226.29	1.558
236.08	1.606
245.68	1.646
256.37	1.695
266.18	1.734
276.56	1.775
286.65	1.816
296.10	1.851

SPECIFIC HEAT OF
TRICALCIUM MAGNESIUM
DISILICON OCTAOXIDE
 $\text{Ca}_3\text{MgSi}_2\text{O}_8$

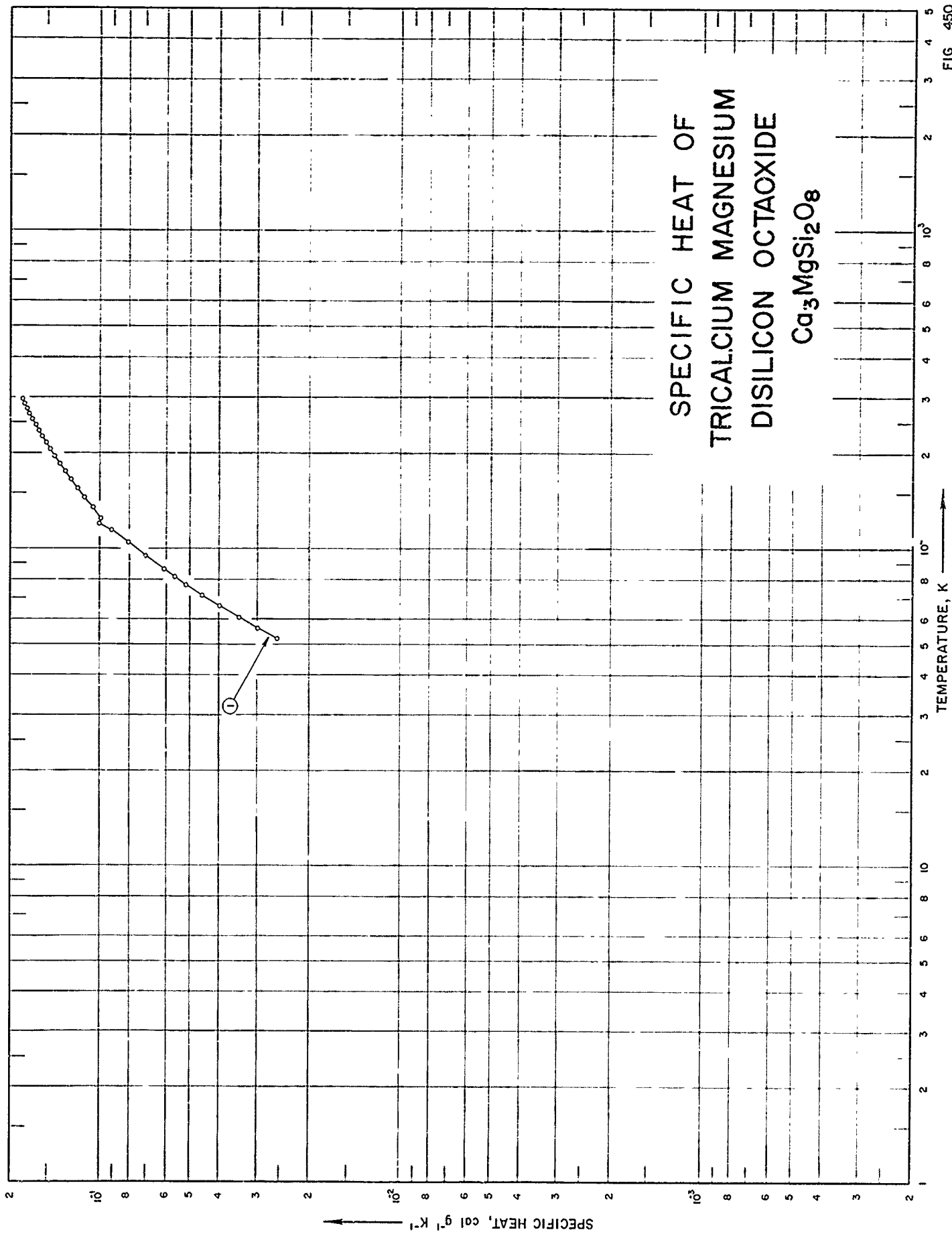

SPECIFICATION TABLE NO. 450 SPECIFIC HEAT OF TRICALCIUM MAGNESIUM DISILICON OCTAOXIDE $\text{Ca}_3\text{MgSi}_2\text{O}_8$

[For Data Reported in Figure and Table No. 450]

Curve No.	Ref. No.	Year	Temp. Range, K	Reported Error, %	Name and Specimen Designation	Composition (weight percent), Specifications and Remarks
1	379	1963	52-296	0.3	Merwinite	71.14 CaO, 36.57 SiO ₂ , 12.23 MgO; prepared by heating reagent-grade calcium carbonate, magnesium oxide, and silica in stoichiometric mixture for 175 hrs at 1100 C, 55 hrs at 1200 C, 50 hrs at 1300 C, and 25 hrs at 1150 C.

DATA TABLE NO. 450 SPECIFIC HEAT OF TRICALCIUM MAGNESIUM DISILICON OCTAOXIDE, $\text{Ca}_3\text{MgSi}_2\text{O}_8$
 [Temperature, T, K; Specific Heat, C_p , Cal g $^{-1}$ K $^{-1}$]

T	C_p
52.05	2.563×10^{-2}
56.18	2.986
60.73	3.444
65.66	3.997
71.20	5.569
76.90	5.178
81.37	5.646
85.98	6.127
94.66	7.006
104.93	8.062
112.50	8.901*
114.75	9.166
115.41	9.251*
118.17	9.647*
120.75	1.008×10^{-1}
123.06	1.009*
124.67	9.963×10^{-2} *
125.38	9.963
136.10	1.061×10^{-1}
146.02	1.128
155.89	1.191
165.79	1.254
176.15	1.315
186.13	1.372
195.88	1.423
206.29	1.474
216.24	1.522
226.32	1.569
236.09	1.611
245.97	1.653
256.32	1.693
266.66	1.731
276.38	1.766
286.92	1.798
296.43	1.829

* Not shown on plot

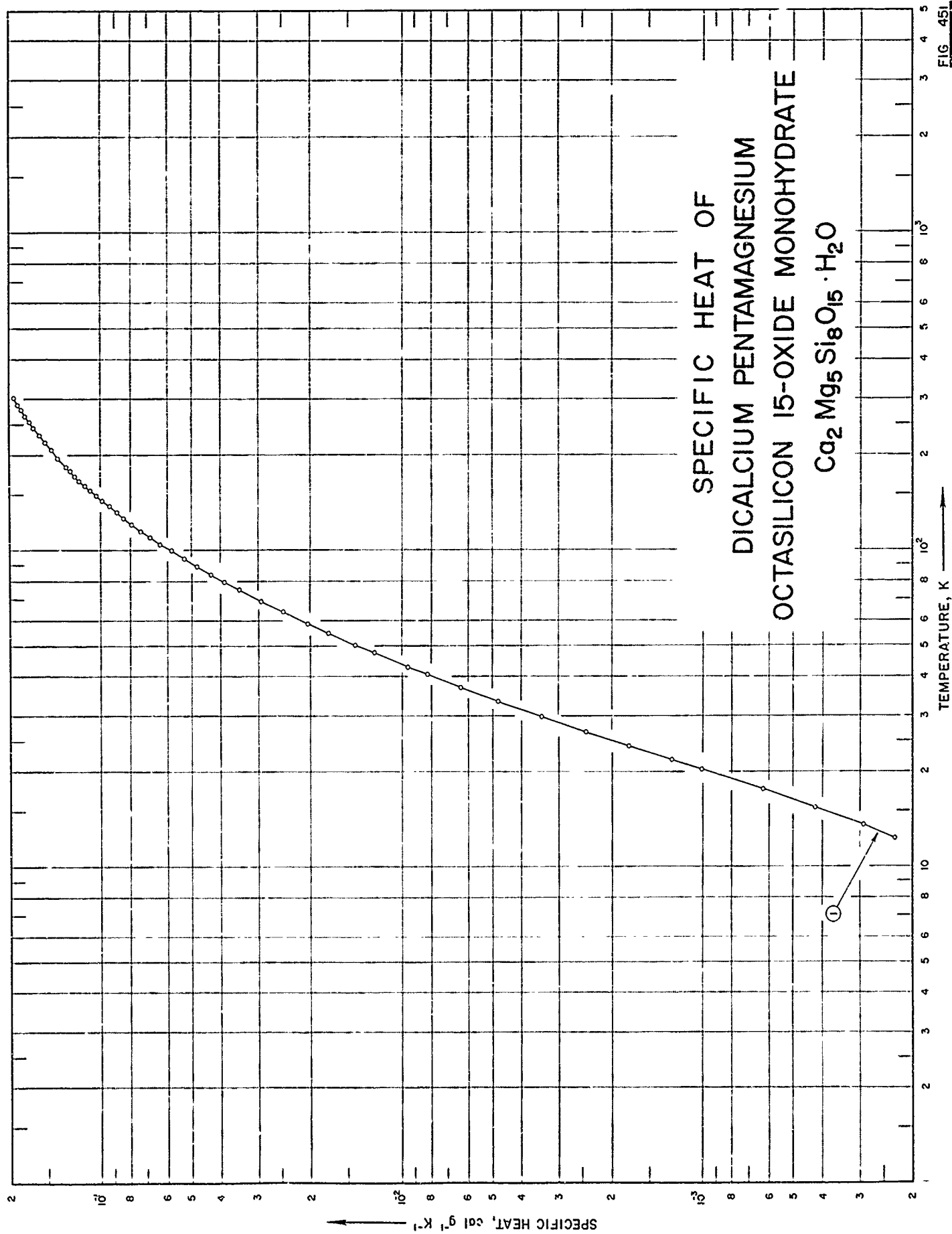

SPECIFICATION TABLE NO. 451 SPECIFIC HEAT OF DICALCIUM PENTAMAGNESIUM OCTASILICON 23-OXIDE MONOHYDRATE $\text{Ca}_2\text{Mg}_5\text{Si}_8\text{O}_{23} \cdot \text{H}_2\text{O}$

[For Data Reported in Figure and Table No. 451]

Curve No.	Ref. No.	Year	Temp. Range, K	Reported Error, %	Name and Specimen Designation	Composition (weight percent), Specifications and Remarks
1	381	1963	12-304	0.3	Tremolite	57.76 SiO ₂ , 25.21 MgO, 12.96 CaO, 2.13 H ₂ O ⁺ , 0.51 Al ₂ O ₃ , 0.43 Na ₂ O, 0.31 CO ₂ , 0.12 K ₂ O, 0.11 FeO, 0.01 MgO, 0.01 P ₂ O ₅ ; single phase crystals, dried at 110 for 2 hrs.

DATA TABLE NO. 451 SPECIFIC HEAT OF DICALCIUM PENTAMAGNESIUM OCTASILICON 23-OXIDE MONOHYDRATE $\text{Ca}_2\text{Mg}_5\text{Si}_8\text{O}_{27} \cdot \text{H}_2\text{O}$ [Temperature, T, K; Specific Heat, Cp, Cal g⁻¹K⁻¹]

T	Cp	T	Cp
CURVE 1		CURVE 1 (cont.)	
Series 1			
54.16	1.696×10^{-2} *	295.48	1.923×10^{-1} *
58.91	2.057	301.18	1.942*
64.06	2.486	304.22	1.956
69.39	2.938	Series 2	
75.26	3.455	249.17	1.707×10^{-1} *
79.83	3.888	255.01	1.737*
84.28	4.312	260.85	1.754*
89.33	4.799	267.13	1.797*
94.53	5.292	273.40	1.829*
100.17	5.827	279.32	1.854*
105.79	6.371	289.13	1.894*
110.92	6.860	294.89	1.915*
116.34	7.381	Series 3	
121.95	7.907	12.37	2.312×10^{-4}
127.41	8.415	13.61	2.925
132.63	8.893	15.49	4.247
138.26	9.396	17.64	6.264
144.22	9.913	20.28	1.005×10^{-3}
149.98	1.040×10^{-1}	21.79	1.268
155.38	1.086	24.08	1.758
161.13	1.133	26.68	2.429
167.02	1.178	29.80	3.427
172.64	1.222	33.38	4.785
178.88	1.268	36.91	6.365
184.86	1.311	40.57	8.214
190.75	1.352*	50.31	1.424×10^{-2}
196.46	1.391	54.93	1.754
202.20	1.428*	42.88	9.520×10^{-3}
208.24	1.467	47.57	1.235×10^{-2}
214.22	1.504*		
220.03	1.539		
225.82	1.574*		
231.42	1.605		
236.91	1.637*		
243.04	1.678		
249.12	1.706*		
254.99	1.737		
260.82	1.766*		
266.63	1.793		
272.62	1.823*		
278.33	1.849		
284.37	1.875*		
289.76	1.898		

* Not shown on plot

FIG. 452

SPECIFIC HEAT OF
COBALT DIIRON TETRAOXIDE
CoFe2O4

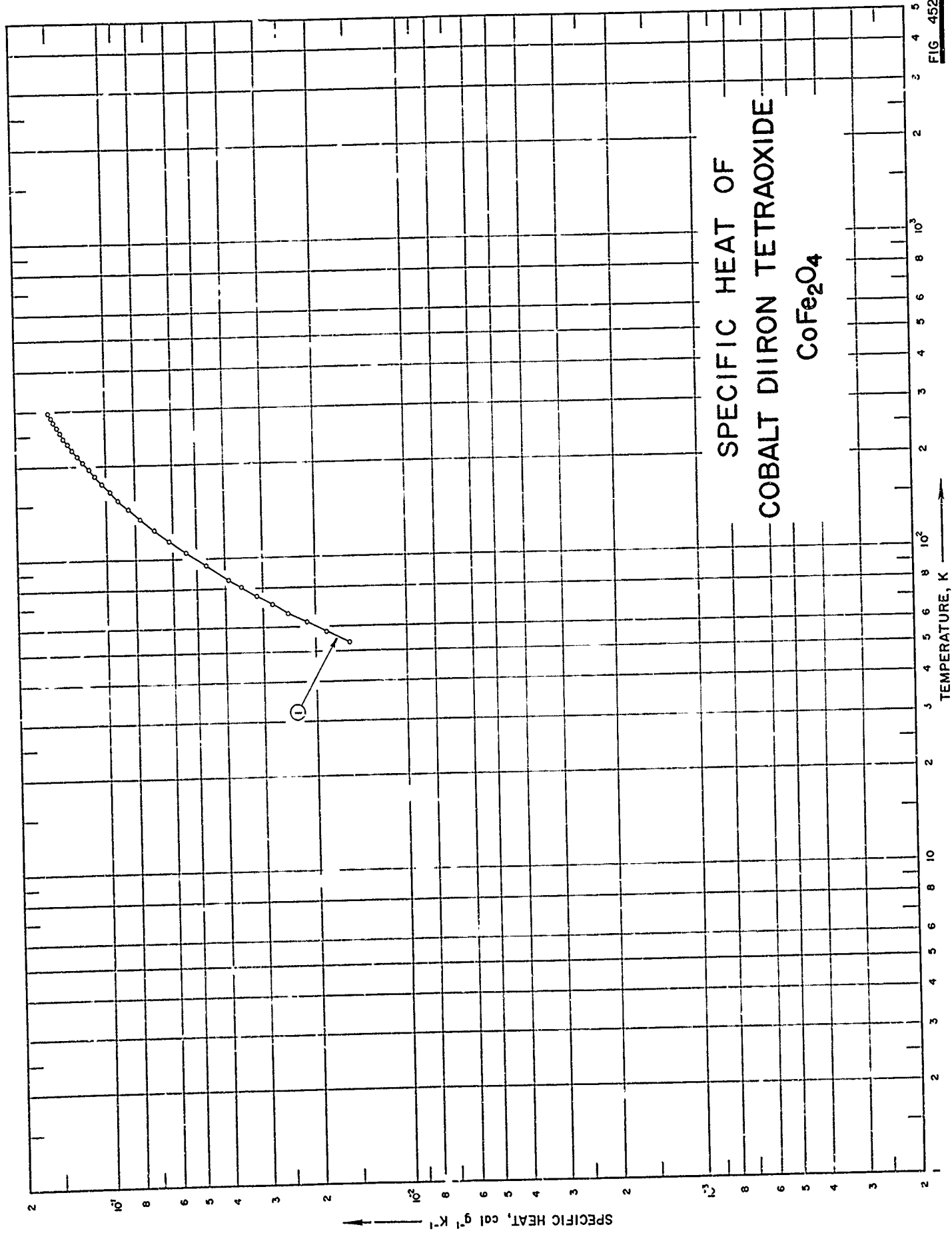

SPECIFICATION TABLE NO. 452 SPECIFIC HEAT OF COBALT DHIRON TETRAOXIDE CoFe_2O_4

[For Data Reported in Figure and Table No. 452]

Curve No.	Ref. No.	Year	Temp. Range, K	Reported Error, %	Name and Specimen Designation	Composition (weight percent), Specifications and Remarks
1	382	1956	53-296		Cobalt-iron spinel	68.08 Fe_2O_3 , 31.96 CoO (68.06, 31.94 theo.), 0.07 SiO_2 ; x-ray diffraction agreed with ASTM; no evidence of uncombined oxides; ground mixed; analyzed, composition adjusted; heated 5 times for a total of 9 days at 950-1350 C.

DATA TABLE NO. 452 SPECIFIC HEAT OF COBALT DIIRON TETRAOXIDE, CoFe_2O_4 [Temperature, T, K; Specific Heat, C_p , Cal $\text{g}^{-1}\text{K}^{-1}$]

T	C_p
	CURVE 1
53.29	1.554×10^{-2}
57.66	1.866
61.98	2.153
66.32	2.482
70.66	2.810
75.17	3.163
80.58	3.569
85.01	3.903
89.04	4.671
105.02	5.442
114.70	6.188
124.59	6.926
135.90	7.740
145.49	8.421
155.70	9.116
165.81	9.743
175.87	1.034×10^{-1}
185.78	1.090
195.98	1.146
206.03	1.199
216.02	1.247
225.80	1.292
236.05	1.336
245.70	1.376
256.42	1.418
266.60	1.454
276.00	1.483
286.35	1.520
296.02	1.550

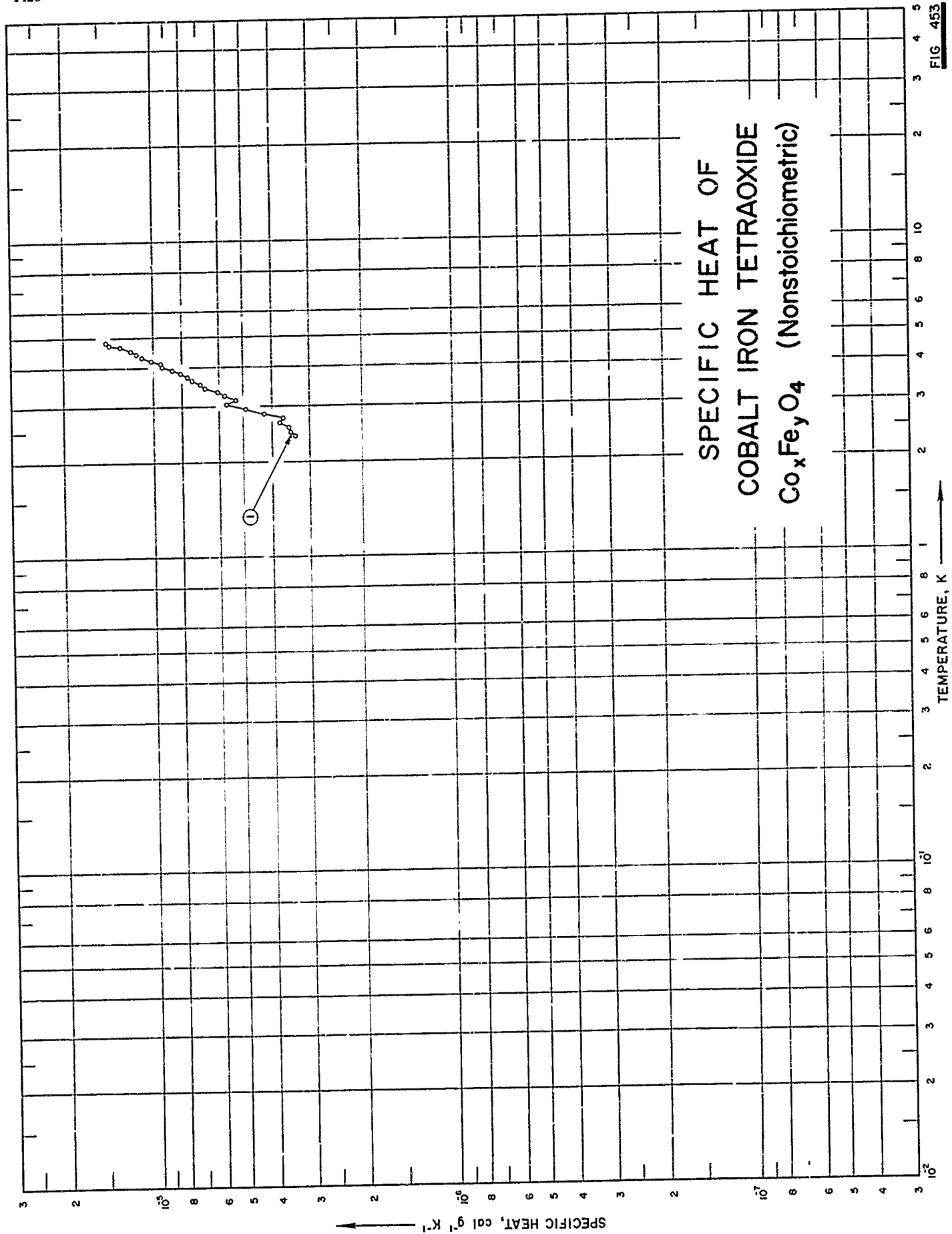

SPECIFICATION TABLE NO. 453 SPECIFIC HEAT OF COBALT IRON TETRAOXIDE (nonstoichiometric) $\text{Co}_x\text{Fe}_y\text{O}_4$

[For Data Reported in Figure and Table No. 453]

Curve No.	Ref. No.	Year	Temp. Range, K	Reported Error, %	Name and Specimen Designation	Composition (weight percent), Specifications and Remarks
1	383	1961	2.4-4.8		$\text{Co}_{0.83}\text{Fe}_2\text{O}_4$	50.27 Fe, 20.12 Co; x-ray density = 5.29 g cm^{-3} ; x-ray lattice parameter = 8.370 \AA ; Curie temperature = 783 K .

DATA TABLE NO. 453 SPECIFIC HEAT OF COBALT IRON TETRAOXIDE, $\text{Co}_x\text{Fe}_y\text{O}_4$ (nonstoichiometric)
 [Temperature, T, K; Specific Heat, C_p , Cal $\text{g}^{-1}\text{K}^{-1}$]

T	C_p
	<u>CURVE 1</u>
	3.36×10^{-6}
2.421	3.49
2.501	3.53
2.583	3.79
2.669	3.68
2.770	4.26
2.854	4.916
2.955	5.678
3.059	5.308
3.151	5.765
3.253	6.083
3.346	6.719
3.437	6.945
3.547	7.398
3.643	7.659
3.741	8.073
3.832	8.617
3.928	9.318
4.024	9.392
4.125	1.010×10^{-5}
4.227	1.096
4.321	1.142
4.427	1.189
4.530	1.203*
4.568	1.291
4.662	1.407
4.748	1.431
4.822	

* Not shown on plot

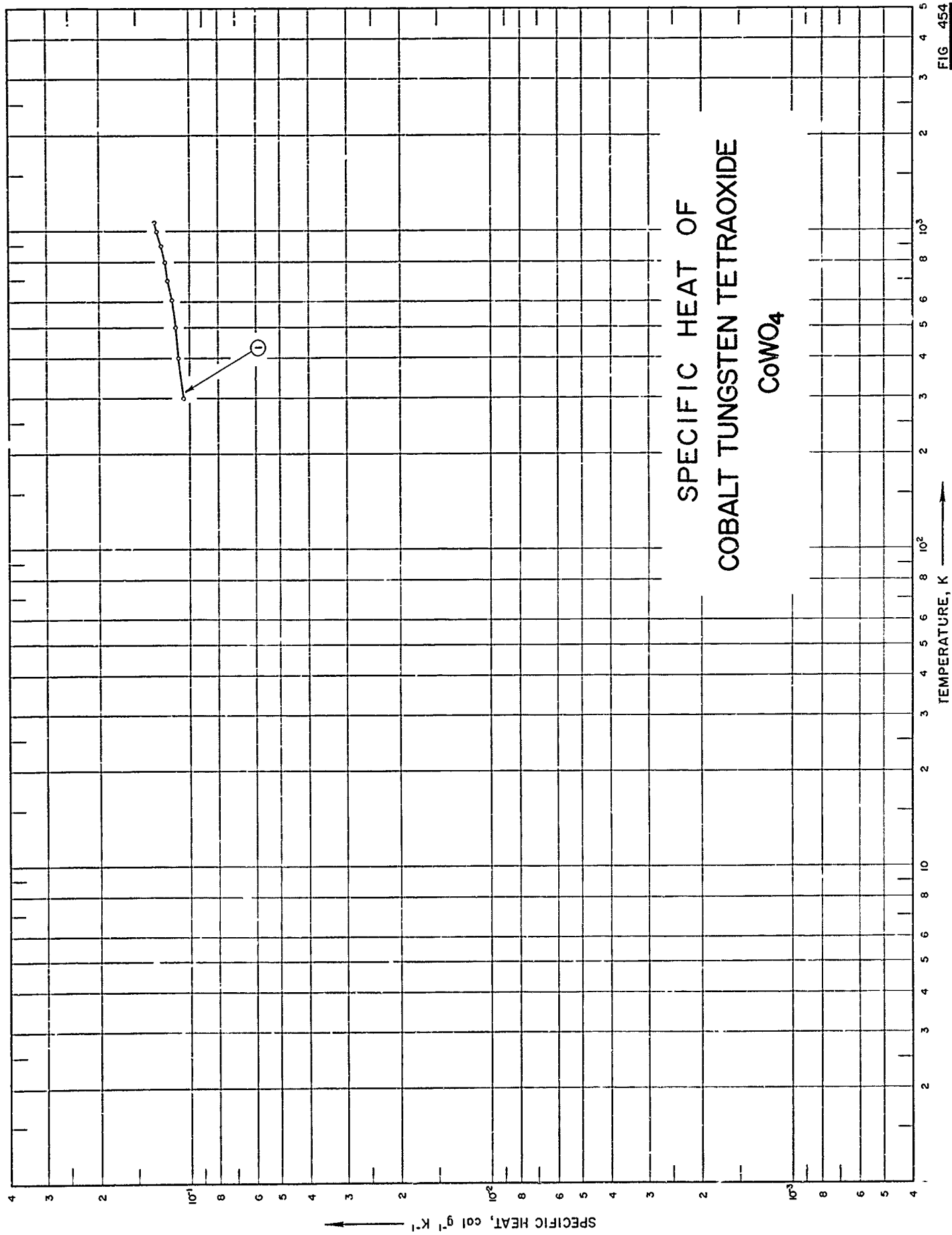

SPECIFIC HEAT, cal g⁻¹ K⁻¹

TEMPERATURE, K

SPECIFICATION TABLE NO. 454 SPECIFIC HEAT OF COBALT TUNGSTEN TETRAOXIDE CoWO_4

[For Data Reported in Figure and Table No. 454]

Curve No.	Ref. No.	Year	Temp. Range, K	Reported Error, %	Name and Specimen Designation	Composition (weight percent), Specifications and Remarks
1	384	1960	300-1073			Prepared by precipitation from $\text{Co}(\text{NO}_3)_2$ solutions with equivalent quantity of K_2WO_4 solution.

DATA TABLE NO. 454 SPECIFIC HEAT OF COBALT TUNGSTEN TETRAOXIDE COWO,
[Temperature, T, K; Specific Heat, C_p , Cal $g^{-1} K^{-1}$]

T	C_p
	<u>CURVE 1</u>
300	1.051×10^{-1}
400	1.084
500	1.117
600	1.149
700	1.182
800	1.215
900	1.247
1000	1.280
1073	1.304

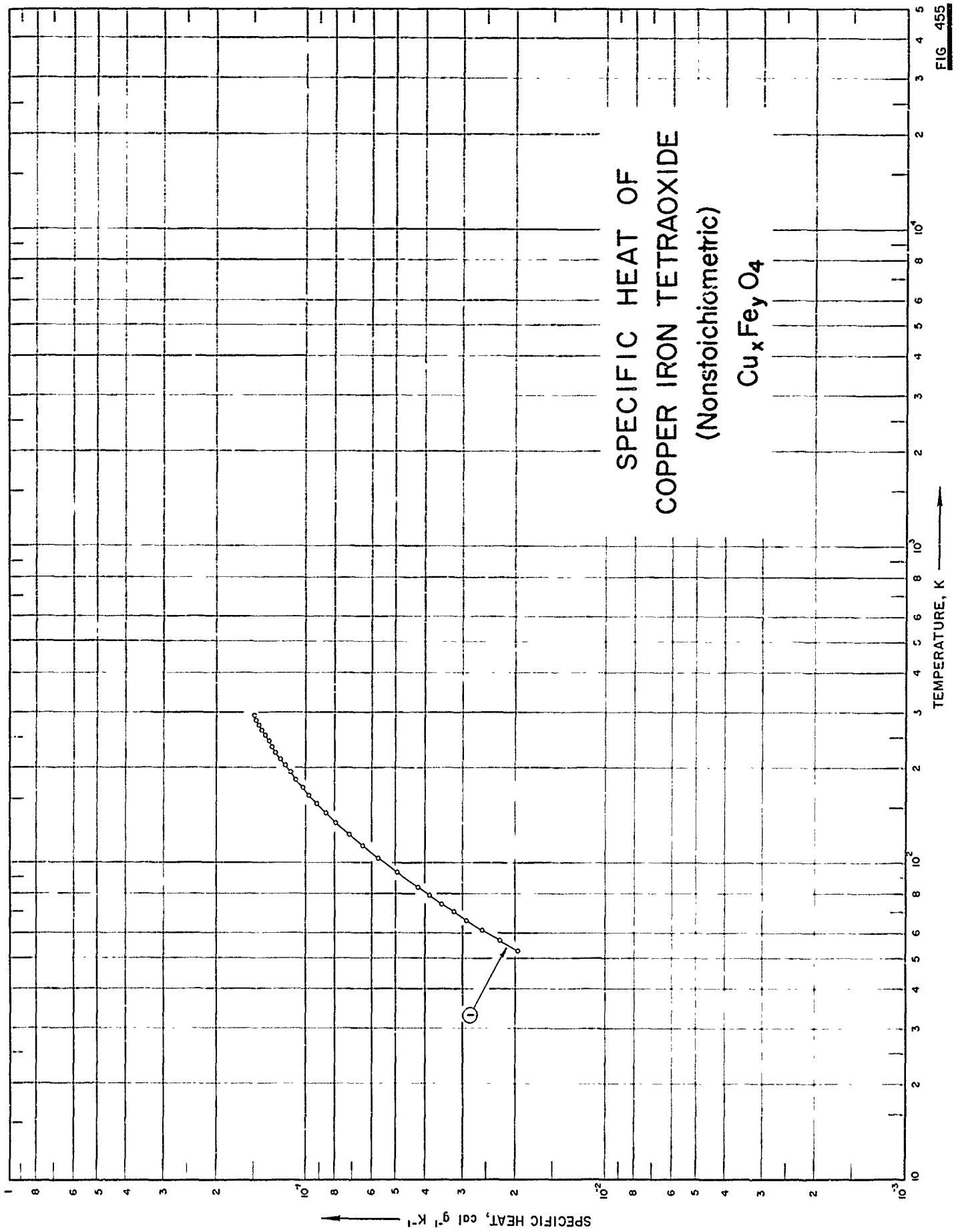

SPECIFICATION TABLE NO. 455 SPECIFIC HEAT OF COPPER IRON TETRAOXIDE (nonstoichiometric) $Cu_xFe_yO_4$

[For Data Reported in Figure and Table No. 455]

Curve No.	Ref. No.	Year	Temp. Range, K	Reported Error, %	Name and Specimen Designation	Composition (weight percent), Specifications and Remarks
1	385	1959	53-296			52.99 Fe, 26.91 O, 20.08 Cu, 0.02 Si; prepared by reacting reagent-grade CuO and Fe ₂ O ₃ for 170 hrs at 900-1000 C, 108 hrs at 1000-1100 C, 48 hrs at 1150 C, and 2 hrs at 1250 C.

DATA TABLE NO. 455 SPECIFIC HEAT OF COPPER IRON TETRAOXIDE $\text{Cu}_x\text{Fe}_y\text{O}_4$ (nonstoichiometric)
 [Temperature, T, K; Specific Heat, C_p , Cal $\text{g}^{-1}\text{K}^{-1}$]

T	C_p
CURVE 1	
53.10	1.994×10^{-2}
57.43	2.286
61.95	2.610
66.47	2.946
70.85	3.271
74.88	3.574
79.69	3.941
84.56	4.290
94.06	5.031
104.73	5.836
114.70	6.561
124.73	7.230
135.93	8.052
145.65	8.706
155.79	9.350
165.95	9.932
175.93	1.048×10^{-1}
185.90	1.101
196.09	1.149
206.40	1.199
216.25	1.243
226.01	1.285
236.02	1.324
245.42	1.359
256.11	1.396
266.19	1.430
276.07	1.463
286.47	1.490
295.99	1.517

SPECIFIC HEAT OF
COPPER DIIRON TETRAOXIDE
CuFe2O4

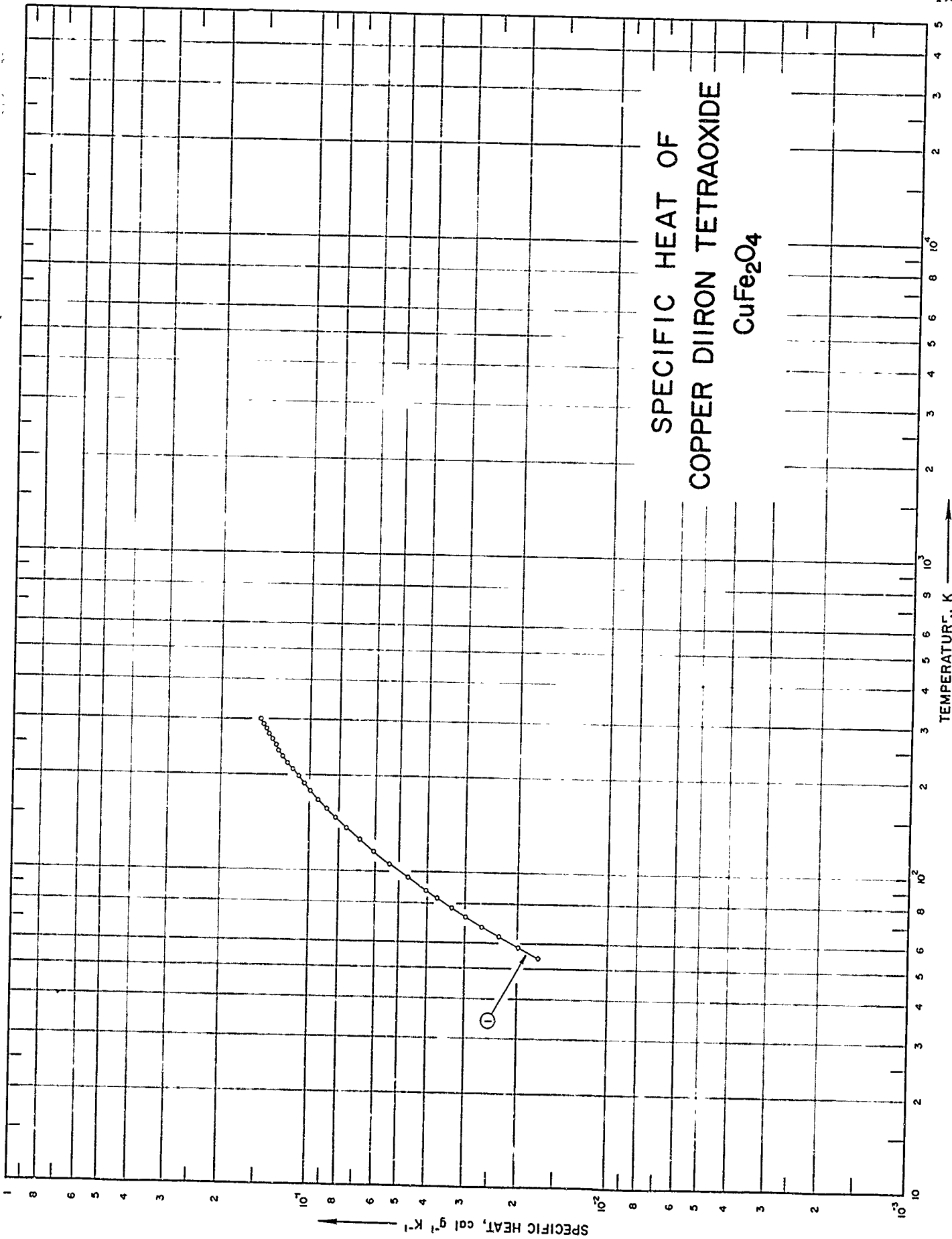

SPECIFICATION TABLE NO. 456 SPECIFIC HEAT OF COPPER BIRON TETRAOXIDE CuFe_2O_4

[For Data Reported in Figure and Table No. 456]

Curve No.	Ref. No.	Year	Temp. Range, K	Reported Error, %	Name and Specimen Description	Composition (weight percent), Specifications and Remarks
1	385	1959	54-296		$\text{Cu}_{40.75}\text{Fe}_{2.25}\text{O}_4$	-46.67 Fe, 26.69 O, 26.57 Cu, 0.05 Si, 0.02 H_2O ; prepared from reagent-grade cupric oxide and ferric oxide by prolonged sintering.

DATA TABLE NO. 456 SPECIFIC HEAT OF COPPER DIIRON TETRAOXIDE CuFe_2O_4 Temperature, T, K Specific Heat, C_p , Cal $\text{g}^{-1}\text{K}^{-1}$

T	C_p
CURVE 1	
53.50	1.701×10^{-2}
57.96	1.993
62.23	2.303
66.81	2.627
71.69	2.982
76.47	3.326
81.78	3.725
86.57	4.069
94.76	4.673
104.87	5.417
114.56	6.107
124.55	6.809
135.64	7.561
145.59	8.226
155.71	8.849
165.73	9.451
176.09	1.001×10^{-1}
186.03	1.055
196.12	1.105
206.12	1.157
216.14	1.202
227.08	1.250
235.97	1.280
245.92	1.318
256.14	1.354
266.37	1.390
276.19	1.422
286.41	1.459
295.91	1.481

SPECIFIC HEAT OF
 TRIERBIUM PENTAGALLIUM DODECAOXIDE
 $Er_3Ga_5O_{12}$ (Garnet)

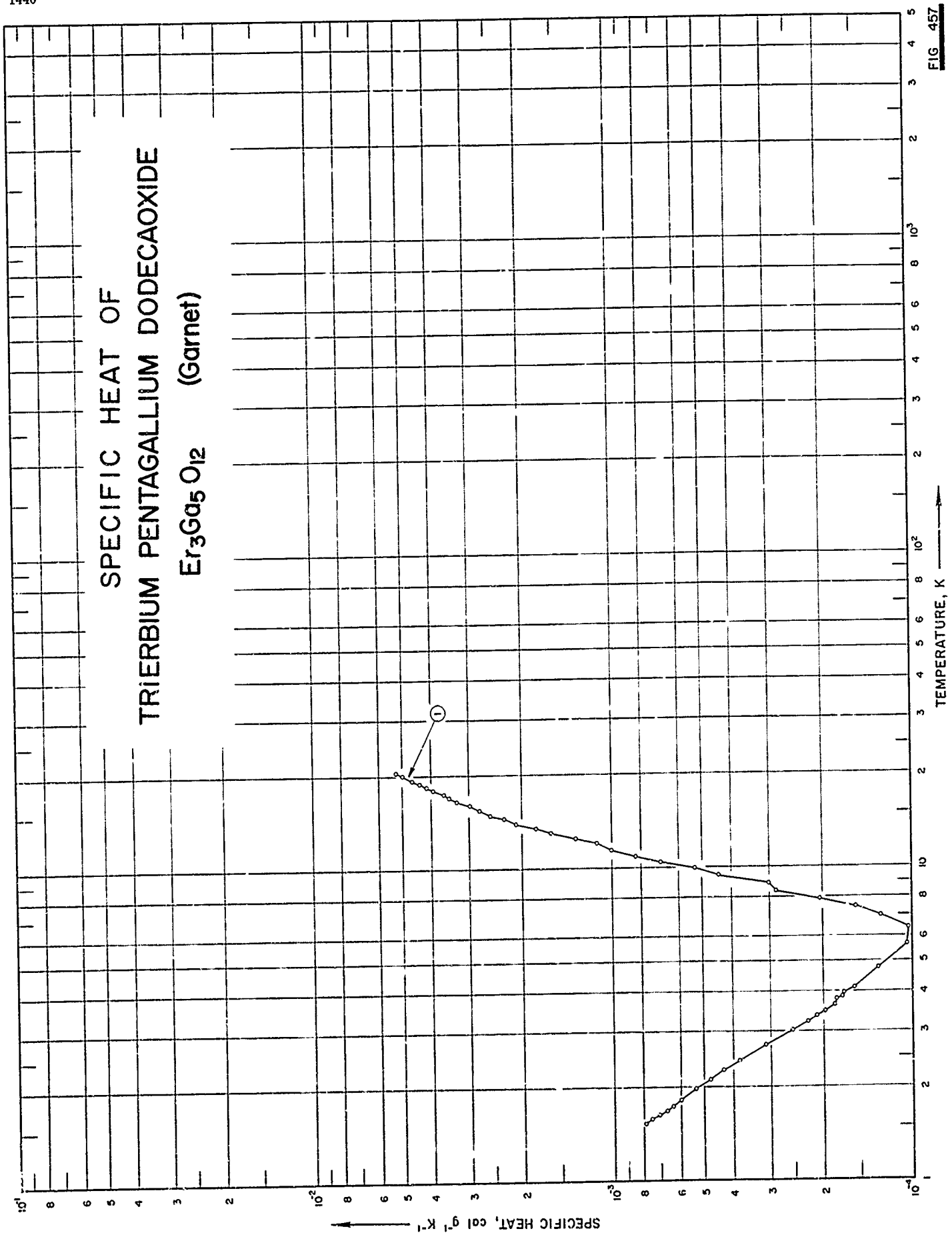

FIG 457

SPECIFICATION TABLE NO. 457 SPECIFIC HEAT OF TRIERBIUM PENTAGALLIUM DODECAOXIDE, $Er_3Ga_5O_{12}$ (Garnet)

[For Data Reported in Figure and Table No. 457]

Curve No.	Ref. No.	Year	Temp. Range, K	Reported Error, %	Name and Specimen Designation	Composition (weight percent), Specifications and Remarks
1	449	1963	1.5-21		Garnet	99.99 Er_2O_3 ; supplied by Lindsay Chem. or Johnson, Matthey Co.; 99.9 Ga_2O_3 ; supplied by the Johnson, Matthey Co.; direct solid state reaction of an intimate mixture of pure rare earth and gallium oxide; sintered block; polycrystalline.

DATA TABLE NO. 457 SPECIFIC HEAT OF TRIERBIUM PENTAGALLIUM DODECAOXIDE, $\text{Er}_3\text{Ga}_5\text{O}_{12}$ (Garnet)
 [Temperature, T, K; Specific Heat, C_p , Cal $\text{g}^{-1}\text{K}^{-1}$]

T	C_p		T	C_p
	CURVE 1	CURVE 1 (cont.)		
1.543	7.910×10^{-4}		17.44	3.646×10^{-3}
1.585	7.521		17.92	3.967
1.635	7.131		18.38	4.173
1.686	6.718		18.81	4.402
1.745	6.421		19.26	4.654
1.827	6.007		19.61	4.723*
1.971	5.365		20.01	5.021
2.114	4.792		20.51	5.274
2.270	4.311			
2.422	3.829			
2.710	3.118			
3.037	2.545			
3.230	2.261			
3.365	2.112			
3.487	1.972			
3.644	1.827			
3.801	1.802			
3.880	1.720			
3.960	1.706			
4.133	1.571			
4.78	1.500			
5.66	1.046			
6.38	1.036			
6.98	1.275			
7.47	1.552			
7.92	2.045			
8.40	2.866			
8.92	3.027			
9.45	4.448			
9.97	5.319			
10.45	6.924			
10.94	8.369			
11.48	1.007×10^{-3}			
12.03	1.126			
12.55	1.323			
13.02	1.607			
13.52	1.798			
13.99	2.091			
14.54	2.281			
14.89	2.568			
15.49	2.774			
16.05	2.981			
16.53	3.302			
17.01	3.508			

* Not shown on plot

SPECIFIC HEAT OF
IRON DIALUMINUM TETRAOXIDE
 $FeAl_2O_4$

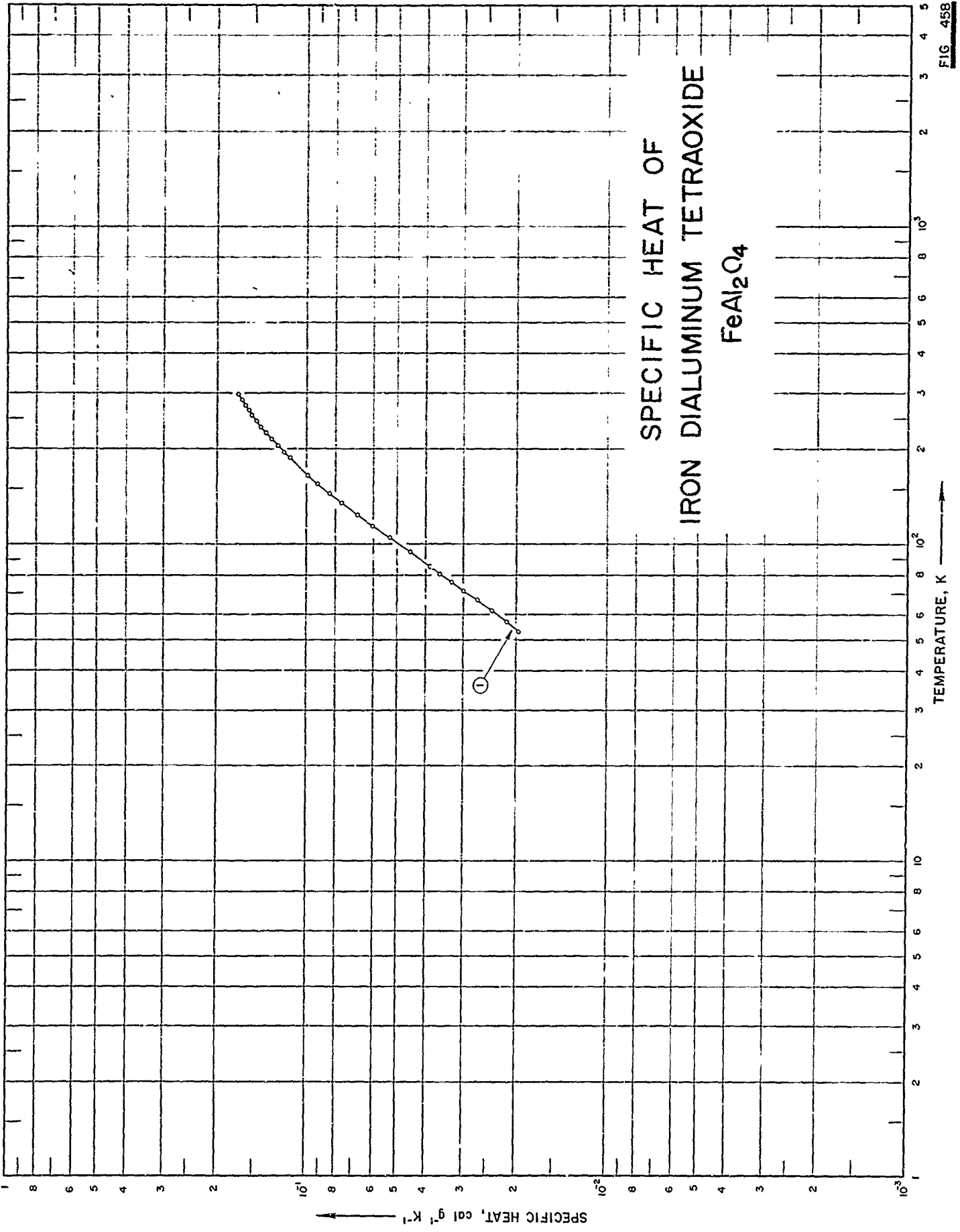

SPECIFICATION TABLE NO. 458 SPECIFIC HEAT OF IRON DIALUMINUM TETRAOXIDE FeAl_2O_4

[For Data Reported in Figure and Table No. 458]

Curve No.	Ref. No.	Year	Temp. Range, K	Reported Error, %	Name and Specimen Designation	Composition (weight percent), Specifications and Remarks
1	382	1956	53-298		Iron-aluminum spinel	58.62 Al_2O_3 , 41.24 FeO (58.66, 41.34 theo.), 0.12 SiO_2 ; prepared from reagent-grade powdered iron, ferric oxide, and hydrated alumina; no evidence of uncombined oxides; metallic Fe on magnetic particle found by x-ray diffraction; heated 7 times (40 hrs total) at 1250-1350 C with grinding and mixing in between.

DATA TABLE NO. 458 SPECIFIC HEAT OF IRON DIALUMINUM TETRAOXIDE FeAl_2O_4 [Temperature, $^{\circ}\text{K}$; Specific Heat, C_p , $\text{Cal g}^{-1}\text{K}^{-1}$]

T	C_p
CURVE 1	
53.04	1.968×10^{-2}
57.12	2.152
61.94	2.407
66.72	2.689
71.29	2.973
76.14	3.279
80.68	3.580
85.24	3.877
94.77	4.531
105.02	5.285
114.50	6.001
124.51	6.778
135.70	7.641
145.20	8.383
155.71	9.194
165.89	9.919
182.92	1.115×10^{-8} *
187.43	1.140
195.89	1.195
206.08	1.259
216.14	1.317
225.66	1.372
236.04	1.427
245.55	1.475
256.48	1.528
266.61	1.572
276.02	1.609
286.31	1.654
296.03	1.685*
298.16	1.699

* Not shown on plot

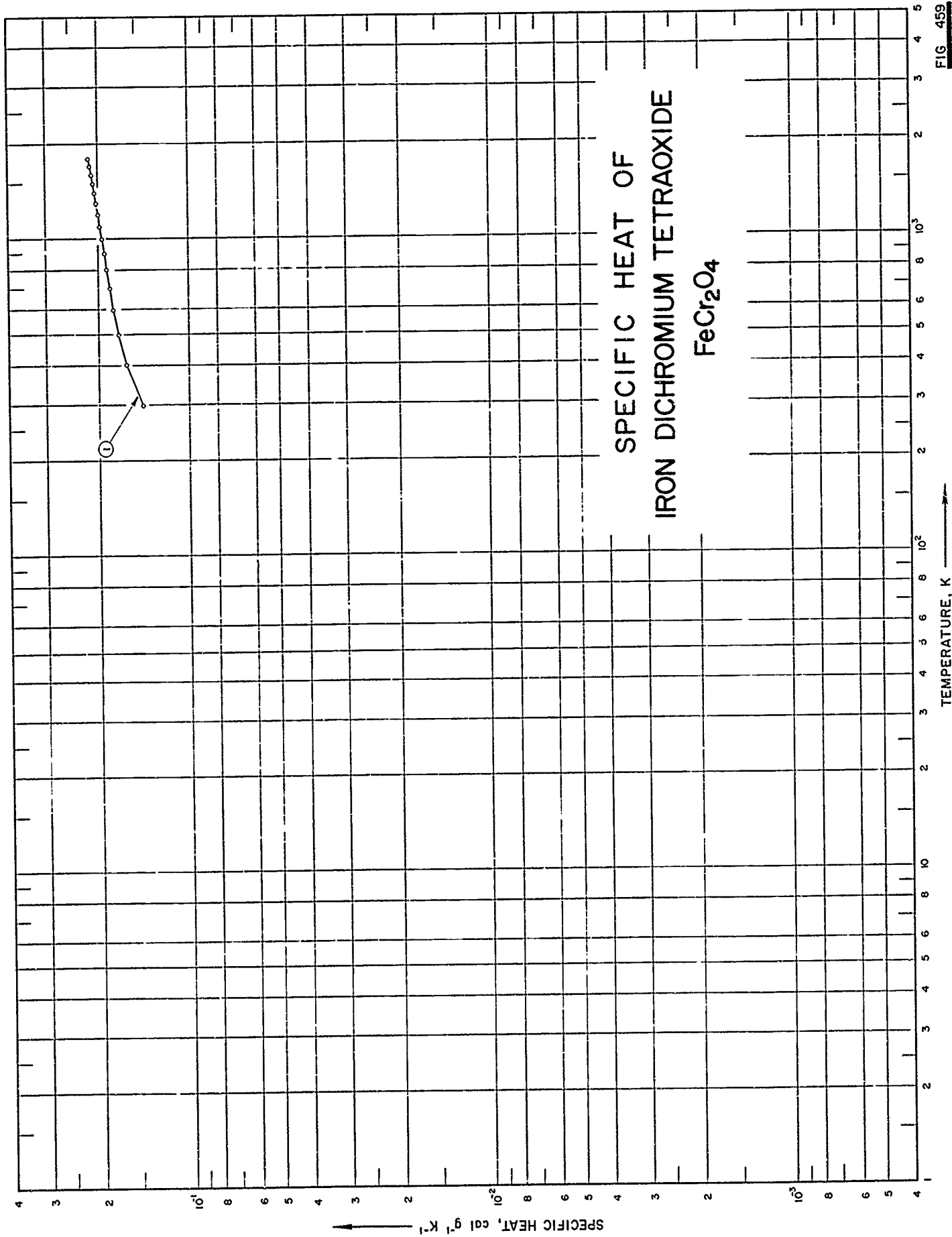

FIG 459

SPECIFICATION TABLE NO. 459 SPECIFIC HEAT OF IRON DICHRONIUM TETRAOXIDE FeCr_2O_4

[For Data Reported in Figure and Table No. 459]

Curve No.	Ref. No.	Year	Temp. Range, K	Reported Error, %	Name and Specimen Designation	Composition (weight percent), Specifications and Remarks
1	386	1944	298-1800	0.3		46.09 Cr, 24.77 Fe, 0.75 SiO_2 ; prepared by heating stoichiometric mixture of high grade sponge iron, reagent-grade ferric oxide, and high-purity chromic oxide at 1300-1350 C for several days in slow stream of He.

DATA TABLE NO. 459 SPECIFIC HEAT OF IRON DICHRONIUM TETRAOXIDE FeC_2O_4
 [Temperature, T, K; Specific Heat, C_p , Cal $\text{g}^{-1}\text{K}^{-1}$]

T	C_p
<u>CURVE 1</u>	
298	1.43×10^{-1}
300	1.435*
400	1.62
500	1.72
600	1.79
700	1.84
800	1.88
900	1.92
1000	1.95
1100	1.98
1200	2.00
1300	2.03
1400	2.06
1500	2.08
1600	2.11
1700	2.13
1800	2.16

* Not shown on plot

SPECIFIC HEAT OF IRON DICOBALT TETRAOXIDE FeCo2O4

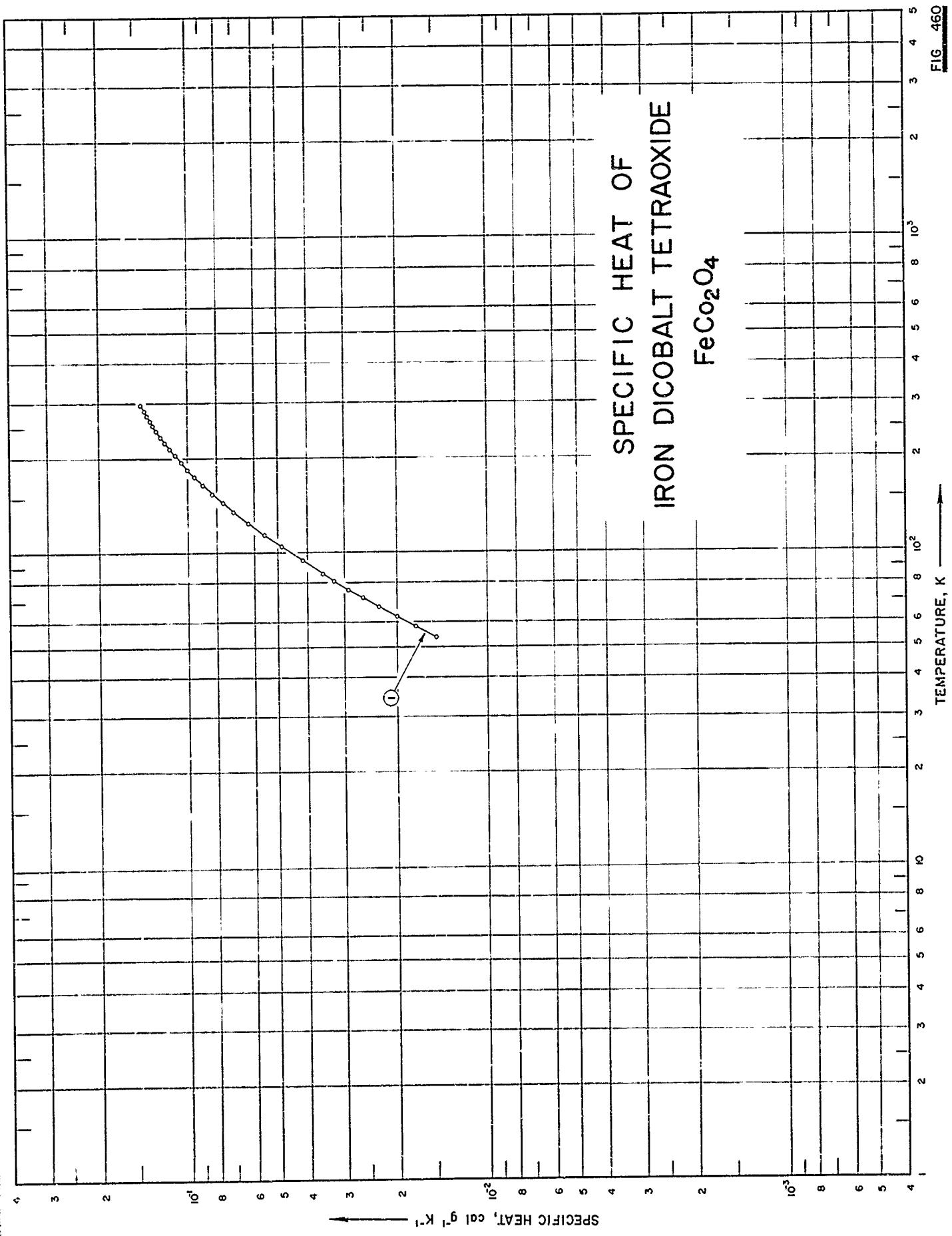

SPECIFICATION TABLE NO. 460 SPECIFIC HEAT OF IRON DICOBALT TETRAOXIDE FeCo_2O_4

[For Data Reported in Figure and Table No. 460]

Curve No.	Ref. No.	Year	Temp. Range, K	Reported Error, %	Name and Specimen Designation	Composition (weight percent)	Specifications and Remarks
1	382	1956	54-298		Iron-cobalt	46.6 Co, 26.88 O, 24.37 Fe; no uncombined oxides found by x-ray diffraction; heated 4 times in air for total of 130 hrs at 1050 C with grinding and mixing in between.	

DATA TABLE NO. 460 SPECIFIC HEAT OF IRON DICOBALT TETRAOXIDE FeCo_2O_4
 [Temperature, T, K; Specific Heat, Cp, Cal $\text{g}^{-1}\text{K}^{-1}$]

T	Cp
<u>CURVE 1</u>	
53.84	1.487×10^{-2}
58.22	1.733
62.66	2.009
67.21	2.303
71.81	2.613
76.38	2.918
81.35	3.257
85.74	3.554
94.55	4.152
105.04	4.884
114.73	5.557
125.12	6.276
136.12	7.021
145.43	7.647
155.56	8.304
165.69	8.909
175.84	9.494
185.63	1.002×10^{-1}
195.84	1.056
206.15	1.108
216.00	1.153
226.03	1.195
236.06	1.237
245.82	1.275
256.26	1.312
266.52	1.346
275.89	1.374
286.46	1.407
295.89	1.437*
298.16	1.442

* Not shown on plot

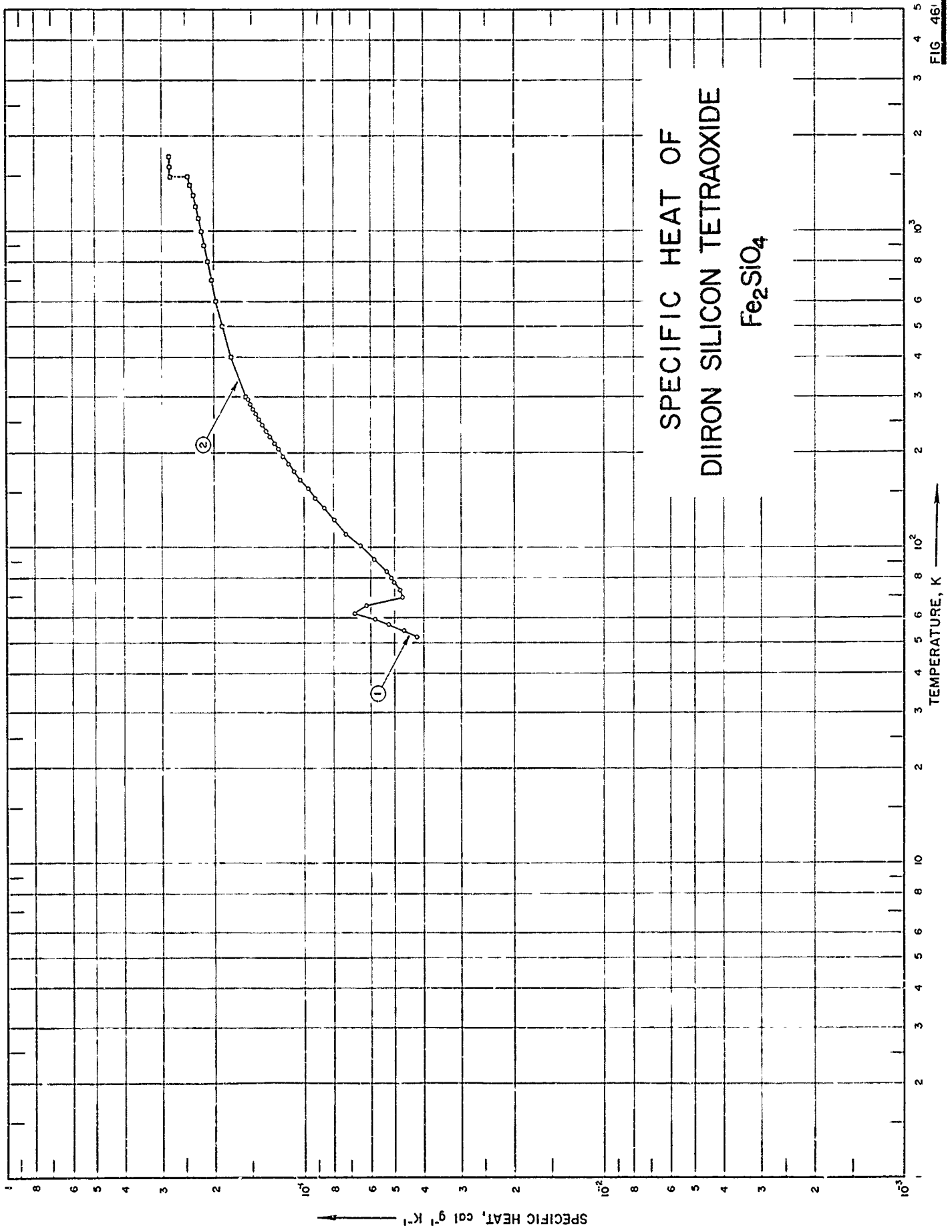

SPECIFICATION TABLE NO. 461 SPECIFIC HEAT OF DIRON SILICON TETRAOXIDE Fe_2SiO_4

[For Data Reported in Figure and Table No. 461]

Curve No.	Ref. No.	Year	Temp. Range, K	Reported Error, %	Name and Specimen Designation	Composition (weight percent), Specifications and Remarks
1	387	1941	52-295			54.5 Fe (54.8 theo.), 29.5 silica; density = 271 lb ft ⁻³ .
2	388	1953	298-1724			54.5 Fe (54.8 theo.), 29.5 silica; density = 271 lb ft ⁻³ .

DATA TABLE NO. 461 SPECIFIC HEAT OF DIIRON SILICON TETRAOXIDE Fe_2SiO_4
 [Temperature, T, K; Specific Heat, C_p , Cal $\text{g}^{-1}\text{K}^{-1}$]

T	C_p		T	C_p
	CURVE 1	CURVE 2 (cont.)		
52.2	4.235×10^{-2}		1200	2.32×10^{-1}
54.6	4.659		1300	2.37
57.3	5.232		1400	2.42
59.5	5.840		(s) 1490	2.46
62.1	6.812		(l) 1490	2.82
65.5	6.228		1500	2.82*
69.5	4.696		1600	2.82
73.6	4.794		1700	2.82*
77.6	5.006		1724	2.82
80.3	5.114			
84.3	5.345			
92.3	5.855			
102.1	6.547			
113.0	7.278			
123.5	7.951			
133.5	8.579			
144.2	9.212			
154.1	9.737			
164.5	1.036×10^{-1}			
174.4	1.083			
184.7	1.135			
194.8	1.180			
205.1	1.226			
214.9	1.263			
224.7	1.305			
235.3	1.347			
245.2	1.383			
255.7	1.422			
265.5	1.457			
275.5	1.485			
285.5	1.522			
295.2	1.549			
CURVE 2				
298	1.56×10^{-2} *			
300	1.56			
400	1.77			
500	1.89			
600	1.98			
700	2.05			
800	2.11			
900	2.16			
1000	2.22			
1100	2.27			

* Not shown on plot

FIG. 462

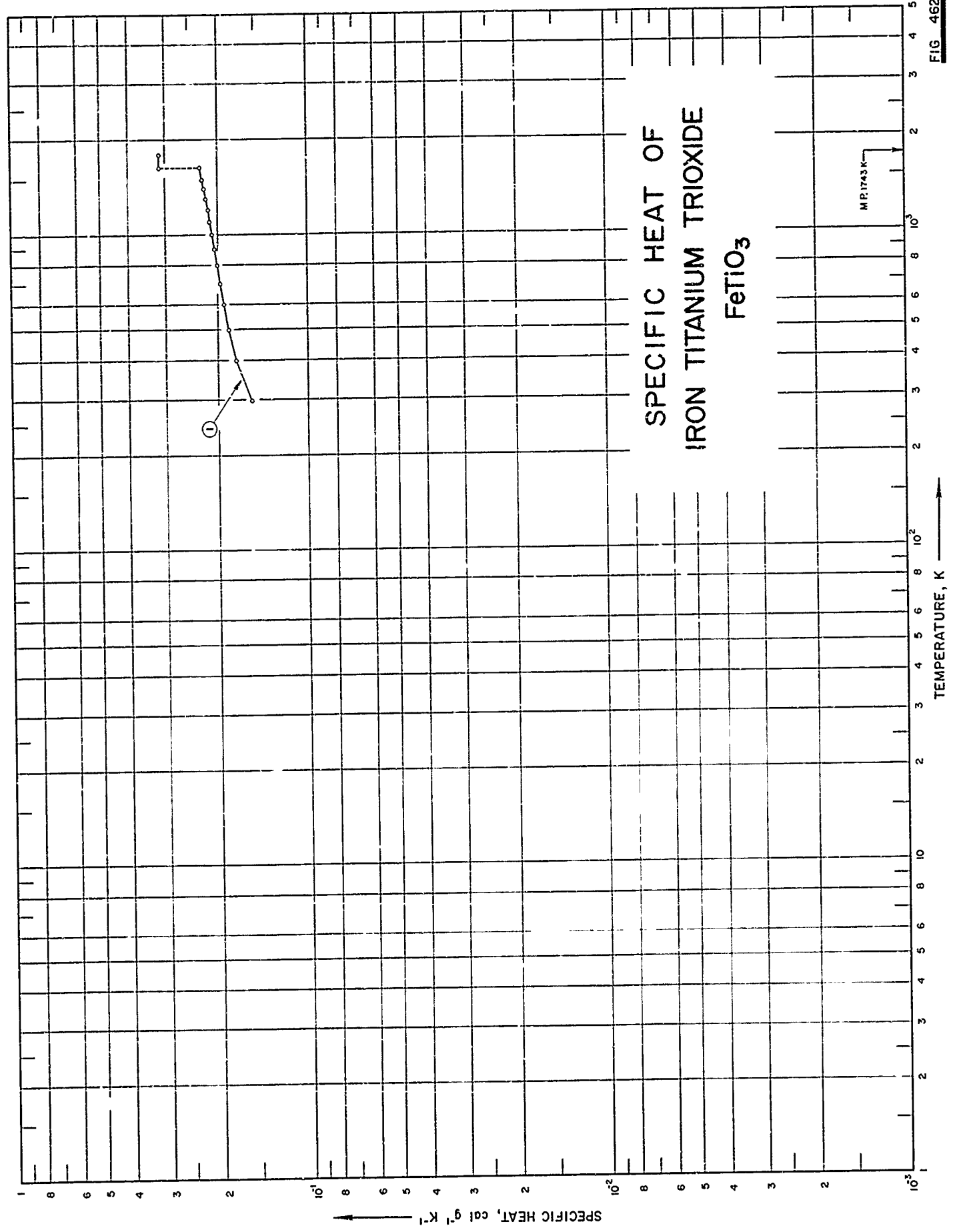

8-115

SPECIFICATION TABLE NO. 462 SPECIFIC HEAT OF IRON TITANIUM TRIOXIDE FeTiO_3

[For Data Reported in Figure and Table No. 462]

Curve No.	Ref. No.	Year	Temp. Range, K	Reported Error, %	Name and Specimen Designation	Composition (weight percent), Specifications and Remarks
1	374	1946	298-1800		Ilmenite	99.4 FeTiO_3 ; 0.6 silica; powdered raw materials mixed and heated in vacuum for 30 hrs at 1165-1300 C.

DATA TABLE NO. 462 SPECIFIC HEAT OF IRON TITANIUM TRIOXIDE FeTiO_3 [Temperature, T, K; Specific Heat, C_p , Cal $\text{g}^{-1}\text{K}^{-1}$]

T	C_p
<u>CURVE 1</u>	
298	1.55×10^{-1}
300	1.56*
400	1.75
500	1.85
600	1.92
700	1.97
800	2.02
900	2.05
1000	2.09
1100	2.13
1200	2.16
1300	2.19
1400	2.22
1500	2.25
1600	2.28*
(S)1640	2.30
(I)1640	3.14
1700	3.14*
1800	3.14

* Not shown on plot

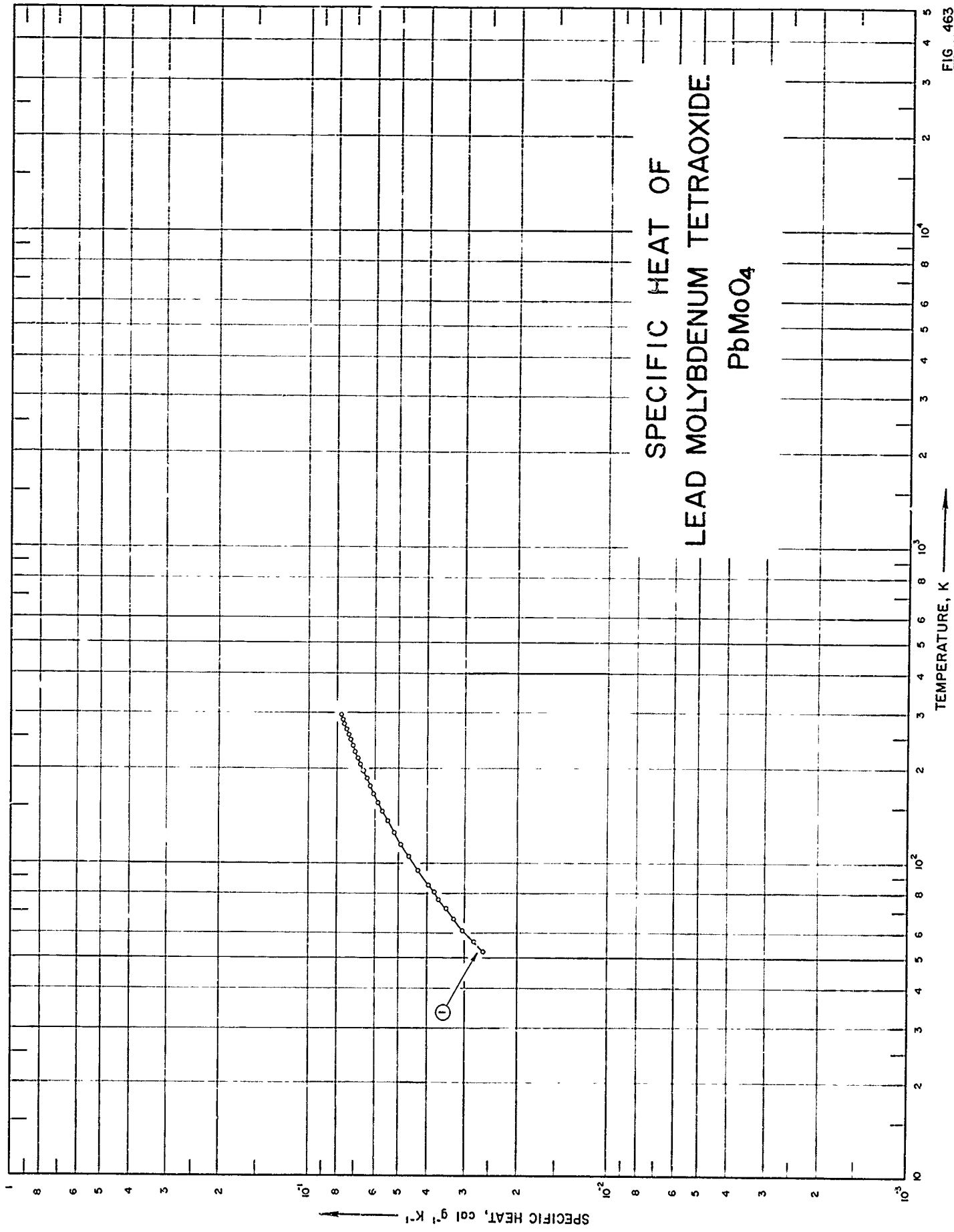

FIG 463

SPECIFICATION TABLE NO. 463 SPECIFIC HEAT OF LEAD MOLYBDENUM TETRAOXIDE $PbMoO_4$

[For Data Reported in Figure and Table No. 463]

Curve No.	Ref. No.	Year	Temp. Range, K	Reported Error, %	Name and Specimen Designation	Composition (weight percent), Specifications and Remarks
1	389	1964	52-296	0.3		60.70 PbO_2 , 39.17 MoO_3 ; prepared from reagent-grade lead nitrate and ammonium molybdate; dried at 500 C; ground to -80 mesh and dried at 640 C.

DATA TABLE NO. 463 SPECIFIC HEAT OF LEAD MOLYBDENUM TETRAOXIDE $PbMoO_4$ [Temperature, T, K; Specific Heat, C_p , Cal $g^{-1}K^{-1}$]

T	C_p
<u>CURVE 1</u>	
52.41	2.588×10^{-2}
56.69	2.795
61.42	3.037
66.54	3.263
71.81	3.465
76.97	3.669
80.61	3.778
85.17	3.969
94.74	4.290
105.23	4.622
114.76	4.900
124.78	5.167
136.03	5.445
145.82	5.663
155.96	5.864
165.64	6.055
175.85	6.235
185.72	6.398
195.80	6.554
206.13	6.709
216.36	6.859
226.42	6.997
236.33	7.120
245.80	7.237
256.22	7.357
266.42	7.471
276.42	7.578
286.86	7.687
296.38	7.774

FIG 464

SPECIFIC HEAT OF
LEAD TUNGSTEN TETRAOXIDE
PbWO4

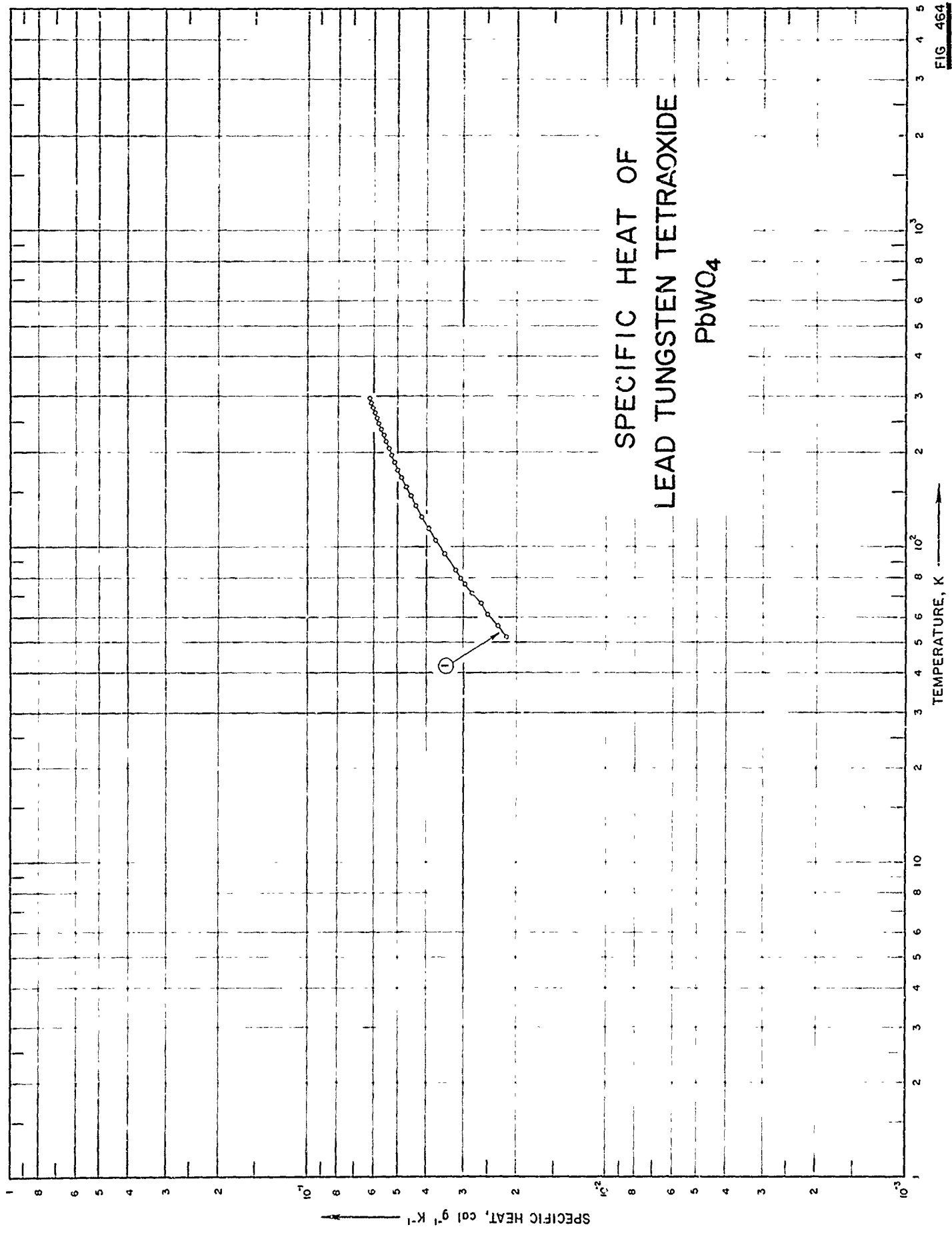

SPECIFICATION TABLE NO. 464 SPECIFIC HEAT OF LEAD TUNGSTEN TETRAOXIDE $PbWO_4$

[For Data Reported in Figure and Table No. 464]

Curve No.	Ref. No.	Year	Temp. Range, K	Reported Error, %	Name and Specimen Designation	Composition (weight percent), Specifications and Remarks
1	389	1964	52-296	0.30		50.94 WO_3 , 48.94 PbO_2 ; prepared from reagent-grade lead carbonate and tungstic acid; stoichiometric mixture heated for several days at 600 C and several days at 700 C.

DATA TABLE NO. 464 SPECIFIC HEAT OF LEAD TUNGSTEN TETRAOXIDE $PbWO_4$ [Temperature, T, K; Specific Heat, Cp, Cal g⁻¹K⁻¹]

T	Cp
<u>CURVE 1</u>	
51.94	2.178 x 10 ⁻²
56.23	2.343
61.11	2.523
66.10	2.650
71.26	2.852
76.31	3.009
79.86	3.116
84.44	3.244
94.89	3.521
105.18	3.771
114.64	3.986
124.66	4.200
135.78	4.408
145.71	4.589
155.72	4.751
166.06	4.912
176.45	5.057
186.08	5.186
195.74	5.303
206.20	5.424
216.40	5.542
226.20	5.643
236.16	5.753
246.04	5.852
256.35	5.945
266.84	6.032
276.54	6.120
286.99	6.202
296.48	6.285

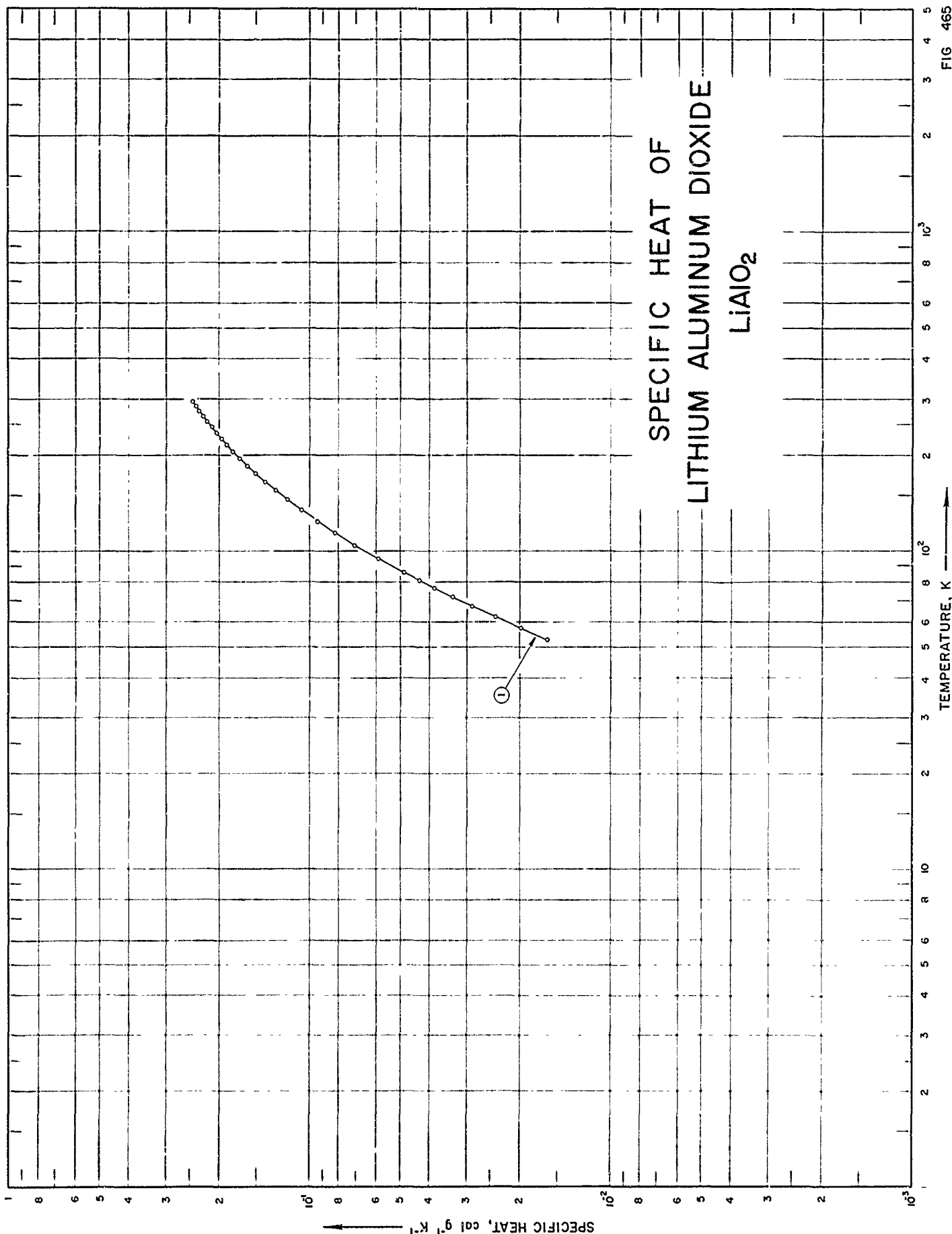

FIG. 465

SPECIFICATION TABLE NO. 465 SPECIFIC HEAT OF LITHIUM ALUMINUM DIOXIDE LiAlO_2

[For Data Reported in Figure and Table No. 465]

Curve No.	Ref. No.	Year	Temp. Range, K	Reported Error, %	Name and Specimen Designation	Composition (weight percent), Specifications and Remarks
1	390	1955	53-296			77.36 Al_2O_3 (77.34 theo.); prepared by prolonged repeated sintering of stoichiometric mixtures of appropriate pure ingredients; heated 50 hrs at 900-1000 C.

DATA TABLE NO. 465 SPECIFIC HEAT OF LITHIUM ALUMINUM DIOXIDE LiAlO_2 [Temperature, T, K; Specific Heat, C_p , Cal $\text{g}^{-1}\text{K}^{-1}$]

T	C_p
CURVE 1	
52.91	1.623×10^{-2}
57.24	1.981
62.24	2.418
67.17	2.884
71.78	3.345
76.54	3.849
80.85	4.320
85.69	4.865
94.75	5.900
104.89	7.092
114.71	8.237
124.43	9.398
135.64	1.070
145.98	1.187
155.83	1.296
165.91	1.404
176.18	1.512
186.01	1.608
195.85	1.701
206.24	1.795
216.04	1.884
226.00	1.966
235.96	2.043
245.70	2.115
255.28	2.194
266.35	2.260
276.13	2.323
286.62	2.385
295.98	2.445

SPECIFIC HEAT OF LITHIUM IRON DIOXIDE LiFeO2

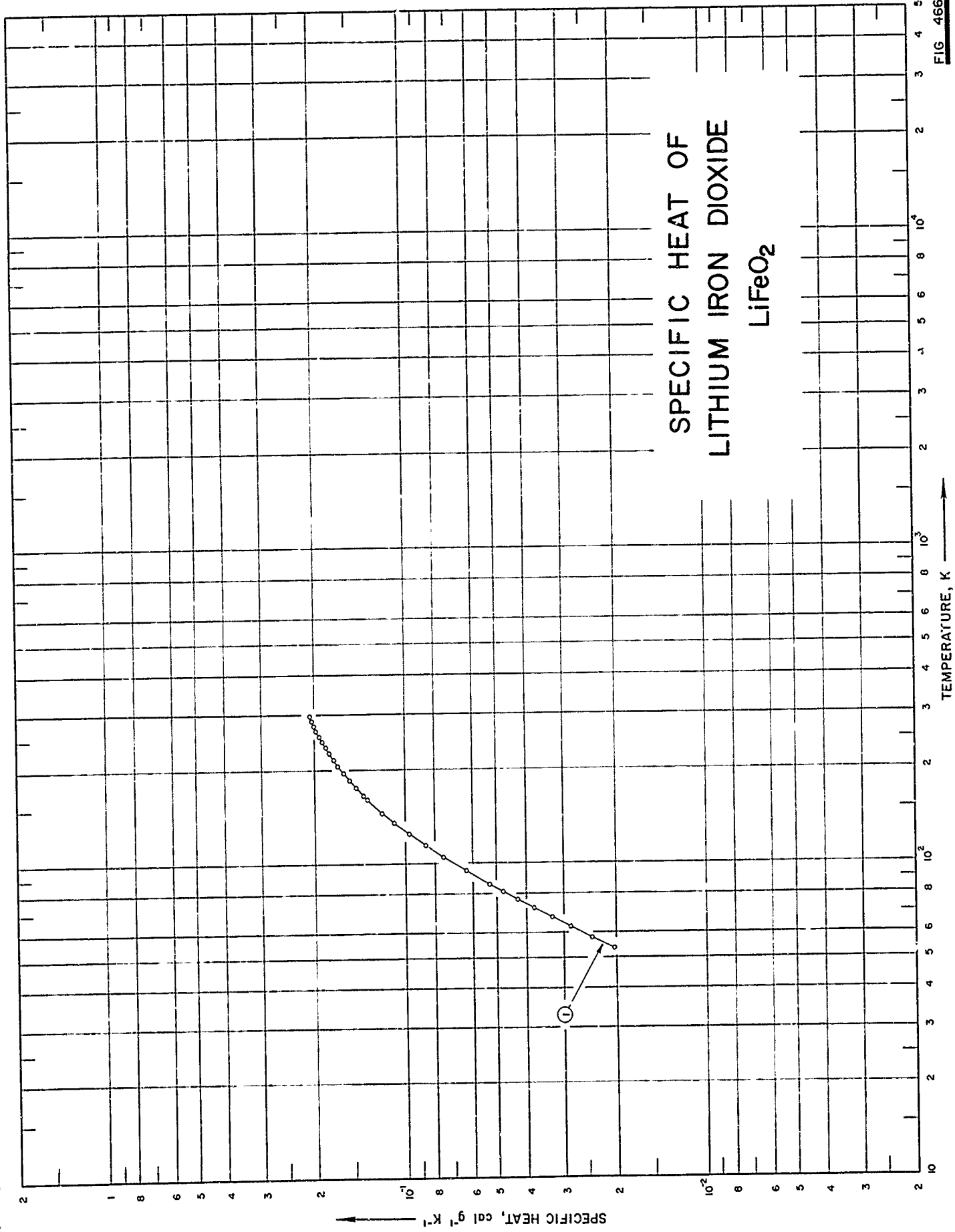

SPECIFICATION TABLE NO. 466 SPECIFIC HEAT OF LITHIUM IRON DIOXIDE LiFeO_2

[For Data Reported in Figure and Table No. 466]

Curve No.	Ref. No.	Year	Temp. Range, K	Reported Error, %	Name and Specimen Designation	Composition (weight percent), Specifications and Remarks
1	390	1955	53.4-296			84.15 Fe_2O_3 (84.24 theo.), 0.09 SiO_2 ; prepared from reagent-grade LiCO_3 and pure Fe_2O_3 ; heated five times for 138 hrs total at 1000-1050 C and 7 hrs at 1150-1200 C.

DATA TABLE NO. 466 SPECIFIC HEAT OF LITHIUM IRON DIOXIDE LiFeO_2 [Temperature, T, K; Specific Heat, C_p , Cal $\text{g}^{-1}\text{K}^{-1}$]

T	C_p
<u>CURVE 1</u>	
53.43	2.049×10^2
57.78	2.423
62.54	2.861
67.12	3.300
71.79	3.773
76.46	4.274
81.09	4.793
85.47	5.297
94.60	6.349
104.75	7.532
114.16	8.620
124.50	9.788
135.78	1.099×10^{-1}
145.48	1.201
160.79	1.346
165.72	1.386
175.93	1.472
185.82	1.548
195.64	1.617
205.96	1.684
215.98	1.745
225.97	1.803
235.98	1.853
245.68	1.897
256.28	1.945
266.33	1.982
276.12	2.016
286.34	2.051
296.01	2.084

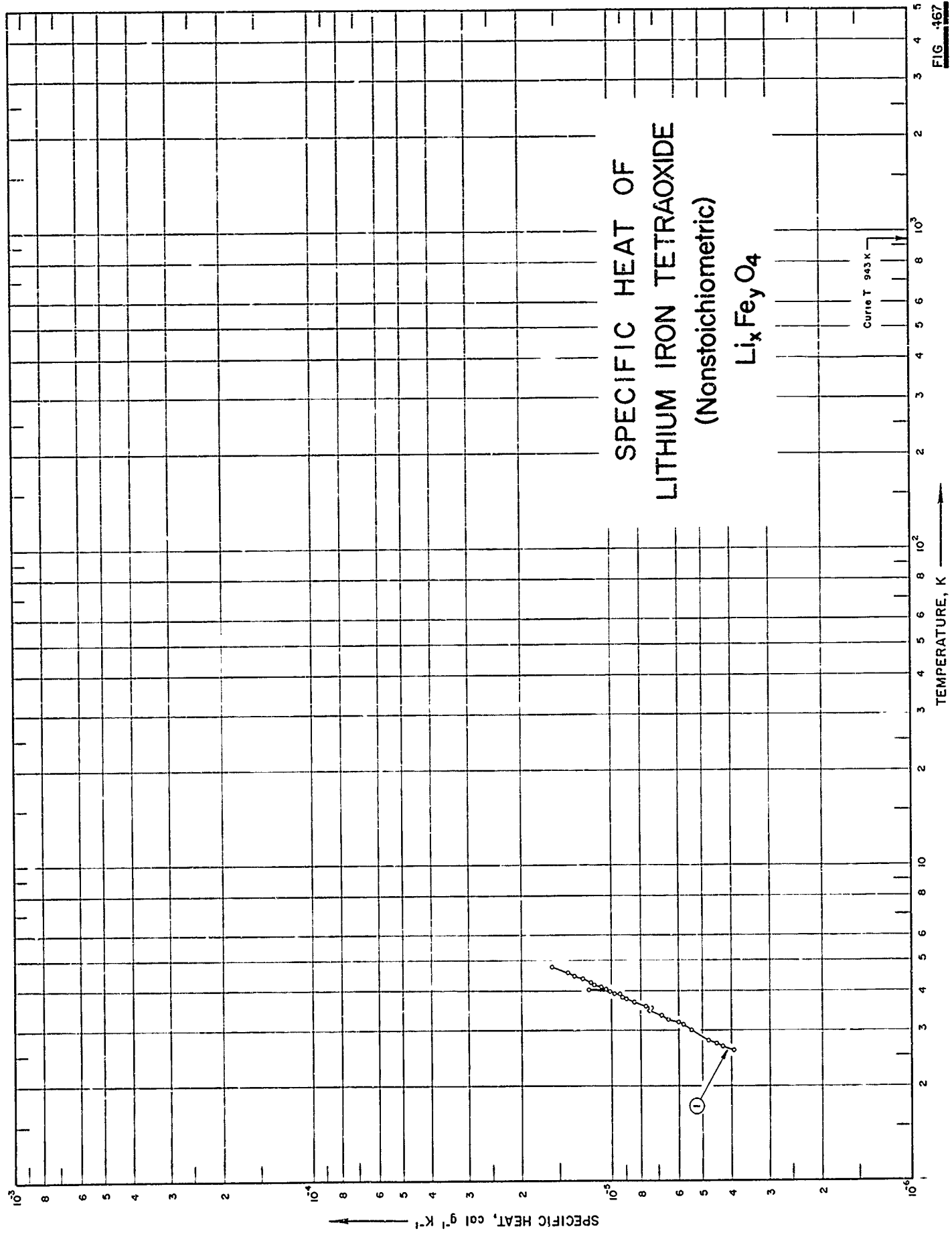

FIG. 167

SPECIFICATION TABLE NO. 467 SPECIFIC HEAT OF LITHIUM IRON TETRAOXIDE (nonstoichiometric) $\text{Li}_x\text{Fe}_y\text{O}_4$

[For Data Reported in Figure and Table No. 467]

Curve No.	Ref. No.	Year	Temp. Range, K	Reported Error, %	Name and Specimen Designation	Composition (weight percent), Specifications and Remarks
1	383	1961	2.6-4.8		$\text{Li}_{0.5}\text{Fe}_2\text{O}_4$	67.20 Fe, 1.71 Li; x-ray density = 4.75 g cm^{-3} ; x-ray lattice parameter = 8.338 \AA ; ordered structure; Curie temperature = 943 K.

DATA TABLE NO. 467 SPECIFIC HEAT OF LITHIUM IRON TETRAOXIDE $\text{Li}_x\text{Fe}_y\text{O}_4$ (nonstoichiometric)
 [Temperature, T, K; Specific Heat, C_p , Cal $\text{g}^{-1}\text{K}^{-1}$]

T	C_p
	CURVE 1
2.599	3.947×10^{-6}
2.669	4.271
2.730	4.480
2.794	4.793
3.006	5.453
3.067	5.481*
3.124	5.819
3.185	6.024
3.242	6.535
3.298	6.535*
3.352	6.855
3.412	6.991*
3.467	7.498
3.527	7.377
3.583	7.735
3.696	8.486
3.778	8.963
3.847	9.251
3.920	9.801
3.920	9.627
3.992	1.019×10^{-5}
4.004	1.016*
4.029	1.214
4.059	1.046
4.132	1.085
4.196	1.158
4.204	1.176
4.395	1.260
4.464	1.341
4.519	1.371*
4.596	1.413
4.653	1.427*
4.720	1.558*
4.779	1.583

* Not shown on plot

SPECIFIC HEAT OF
DILITHIUM TITANIUM TRIOXIDE
 Li_2TiO_3

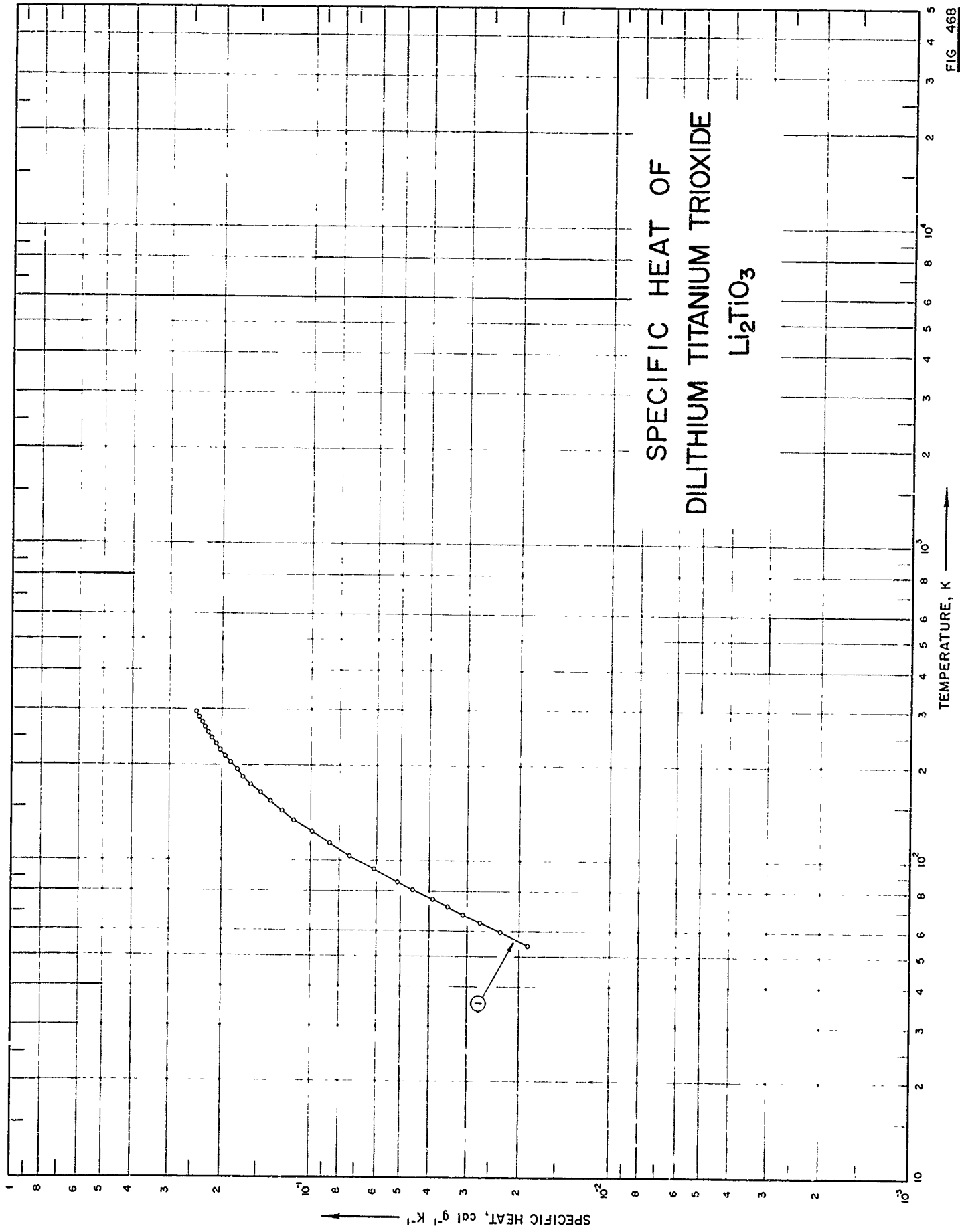

SPECIFICATION TABLE NO. 468 SPECIFIC HEAT OF DILITHIUM TITANIUM TRIOXIDE Li_2TiO_3

[For Data Reported in Figure and Table No. 468]

Curve No.	Ref. No.	Year	Temp. Range, K	Reported Error, %	Name and Specimen Designation	Composition (weight percent), Specifications and Remarks
1	358	1955	55-298			72.70 titania (72.78 theo.), 0.3 silica, 0.06 Pt + Ni; prepared from reagent-grade lithium carbonate and pure titania; heated 6 times for 70 hrs at 1000-1050 C and 30 hrs at 1150 C.

DATA TABLE NO. 468 SPECIFIC HEAT OF DILITHIUM TITANIUM TRIOXIDE Li_2TfO_3 [Temperature, T, K; Specific Heat, Cp, Cal g⁻¹K⁻¹]

T	Cp
CURVE 1	
54.58	1.861×10^{-2}
60.12	2.308
64.35	2.694
68.29	3.076
72.14	3.466
76.04	3.889
81.62	4.534
86.23	5.073
94.65	6.099
104.80	7.388
114.33	8.604
124.20	9.893
135.84	1.132×10^{-1}
145.54	1.250
155.80	1.368
165.68	1.475
175.81	1.581
185.77	1.675
196.16	1.769
206.09	1.854
216.33	1.937
226.09	2.010
235.82	2.074
245.67	2.141
256.13	2.205
266.50	2.263
276.20	2.312
286.44	2.364
295.94	2.407*
298.16	2.418

* Not shown on plot

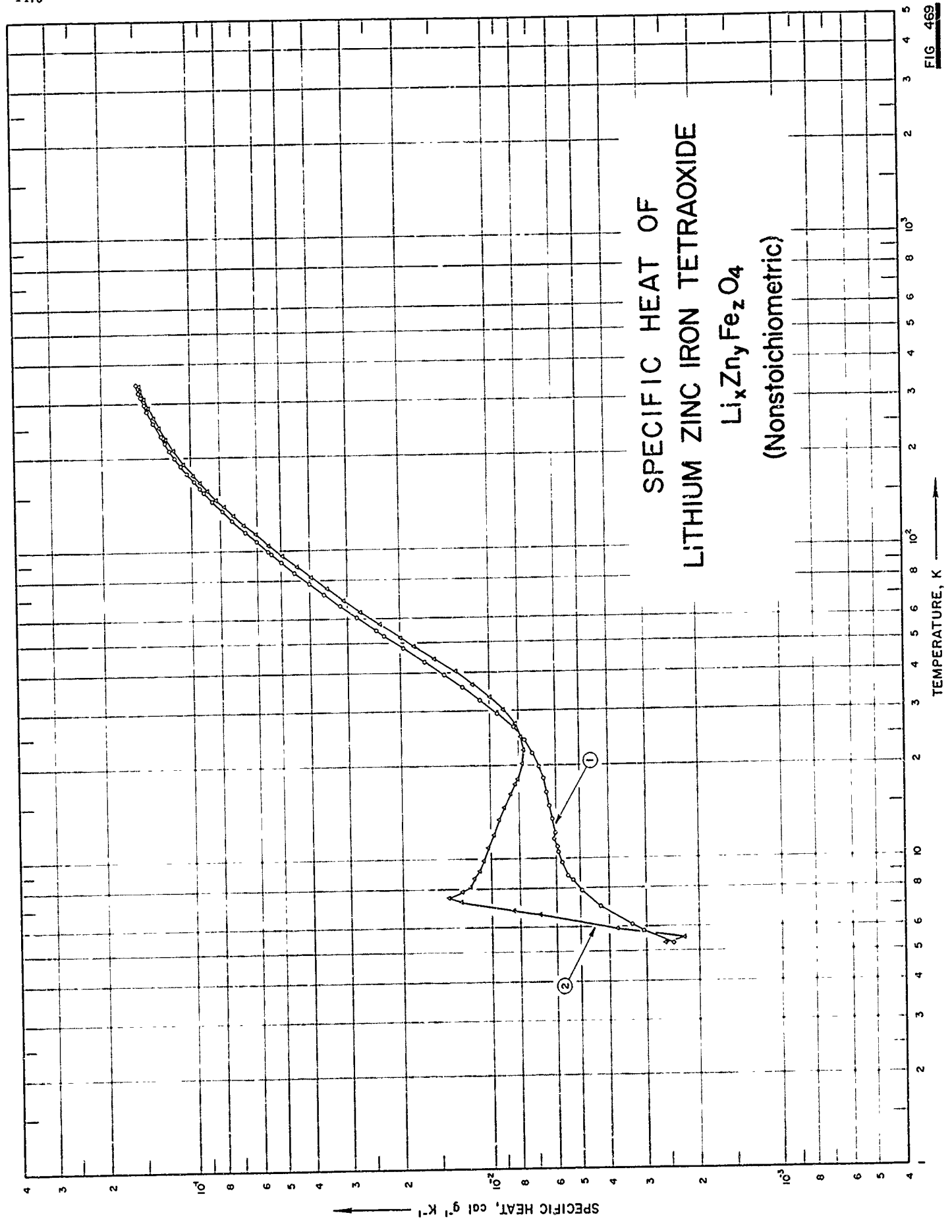

FIG. 469

SPECIFICATION TABLE NO. 469 SPECIFIC HEAT OF LITHIUM ZINC IRON TETRAOXIDE $\text{Li}_x\text{Zn}_y\text{Fe}_z\text{O}_4$ (nonstoichiometric)

[For Data Reported in Figure and Table No. 469]

Curve No.	Ref. No.	Year	Temp. Range, K	Reported Error, %	Name and Specimen Designation	Composition (weight percent), Specifications and Remarks
1	406	1959	5-346		$\text{Li}_0.6\text{Zn}_0.90\text{Fe}_2.0\text{O}_4$	48.0 Fe, 24.4 Zn, 0.12 Li; quenched.
2	406	1959	5-344		$\text{Li}_0.6\text{Zn}_0.90\text{Fe}_2.0\text{O}_4$	47.9 Fe, 24.4 Zn, 0.11 Li; annealed.

DATA TABLE NO. 469 SPECIFIC HEAT OF LITHIUM ZINC IRON TETRAOXIDE $\text{Li}_x\text{Zn}_y\text{Fe}_z\text{O}_2$ (nonstoichiometric)
 [Temperature, T, K; Specific Heat, C_p , Cal $\text{g}^{-1}\text{K}^{-1}$]

T	C_p	T	C_p	T	C_p	T	C_p
CURVE 1 (cont.)							
Series I							
97.48	5.370×10^{-2}	5.29	2.4×10^{-3}	121.58	6.662×10^{-2}	5.05	2.2×10^{-3}
106.78	6.008*	6.08	3.4	130.20	7.224	5.92	4.0*
116.58	6.658*	6.99	4.29	138.62	7.751	6.79	8.46
125.95	7.285	7.86	4.97	147.26	8.274	7.49	1.41×10^{-2}
135.26	7.880	8.76	5.51	156.38	8.802	8.14	1.18
145.05	8.482	9.66	5.76	165.95	9.328	9.07	1.12*
155.38	9.079	10.58	5.93	175.77	9.837	10.08	1.06*
159.74	9.323	11.61	6.14	182.75	1.018×10^{-1}	11.07	1.02*
167.88	9.765	Series IV					
178.05	1.027×10^{-1}	201.81	1.104*	201.81	1.143	27.41	8.293×10^{-3}
188.81	1.078	211.33	1.143	211.33	1.143	30.22	8.983
200.35	1.130	220.85	1.179*	220.85	1.179*	33.21	9.988
212.09	1.178	230.52	1.215×10^{-2}	230.52	1.215	36.50	1.133×10^{-2}
224.23	1.223	240.20	1.247*	240.20	1.247*	40.21	1.309
236.40	1.266	250.07	1.279	250.07	1.279	44.35	1.529
248.41	1.305*	260.05	1.309*	260.05	1.309*	48.87	1.791
260.56	1.340	270.14	1.336	270.14	1.336		
272.60	1.373*	280.12	1.362*	280.12	1.362*		
284.59	1.403	290.23	1.387	290.23	1.387		
296.72	1.430*	300.48	1.410*	300.48	1.410*		
		310.90	1.433	310.90	1.433		
		321.53	1.453*	321.53	1.453*		
		332.39	1.474	332.39	1.474		
		343.39	1.493	343.39	1.493		
Series V							
5.81	3.1×10^{-3}	287.47	1.410×10^{-4}	Series II			
6.91	4.25*	297.28	1.431	5.29	2.6×10^{-3}		
8.51	5.34	307.03	1.451*	5.90	3.9		
8.70	5.47*	316.67	1.472	6.58	6.90		
9.76	5.76*	326.27	1.489	7.19	1.28×10^{-2}		
10.95	5.97	335.96	1.506*	7.82	1.27		
12.20	6.088	345.79	1.523	8.63	1.15		
13.43	6.239	CURVE 2					
14.79	6.353	Series I					
16.37	6.475	52.10	1.988×10^{-2}	10.76	1.03		
18.11	6.639	57.64	2.336	11.96	9.85 $\times 10^{-3}$		
19.89	6.866	63.14	2.700	13.27	9.42		
21.85	7.216	68.96	3.084	14.64	9.016		
24.12	7.691	75.23	3.505	16.13	8.579		
26.64	8.301	81.72	3.959	18.00	8.141		
29.48	9.445	88.65	4.442	20.14	7.834		
32.54	1.075×10^{-2}	96.22	4.955	22.34	7.754		
35.77	1.231	104.29	5.501	24.64	7.876		
39.35	1.422	112.84	6.080	27.16	8.246		
43.41	1.654						
48.08	1.950						
52.80	2.265						

* Not shown on plot

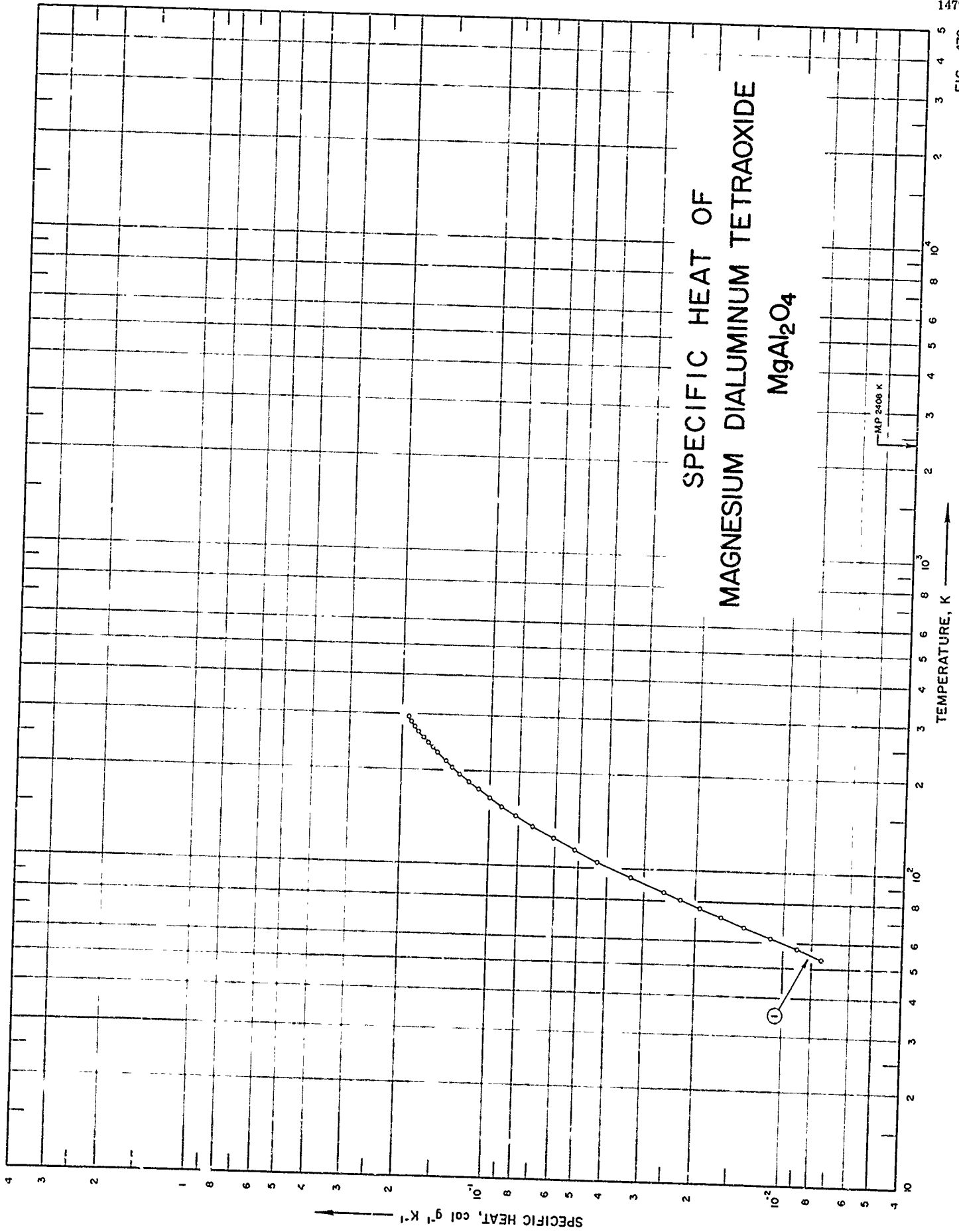

SPECIFICATION TABLE NO. 470 SPECIFIC HEAT OF MAGNESIUM DIALUMINUM TETRAOXIDE $MgAl_2O_4$

[For Data Reported in Figure and Table No. 470]

Curve No.	Ref. No.	Year	Temp. Range, K	Reported Error, %	Name and Specimen Designation	Composition (weight percent), Specifications and Remarks
1	365	1955	54-286		Magnesium-aluminum spinel	71.62 Al_2O_3 , 28.33 MgO (71.66, 28.34 theo.).

DATA TABLE NO. 470 SPECIFIC HEAT OF MAGNESIUM DIALUMINUM TETRAOXIDE $MgAl_2O_4$ [Temperature, T, K; Specific Heat, C_p , Cal $g^{-1}K^{-1}$]

T	C_p
CURVE 1	
53.55	7.450×10^{-3}
57.72	9.017
62.19	1.118×10^{-2}
66.84	1.373
71.51	1.645
76.17	1.939
80.80	2.257
85.02	2.572
94.43	3.329
105.62	4.344
114.95	5.190
124.87	6.141
135.89	7.232
146.36	8.216
156.37	9.214
165.90	1.014×10^{-1}
175.91	1.106
185.86	1.193
196.21	1.281
206.36	1.362
216.32	1.427
228.03	1.529
237.36	1.588
245.85	1.650
256.37	1.716
266.66	1.776
276.12	1.829
286.34	1.890
296.31	1.920

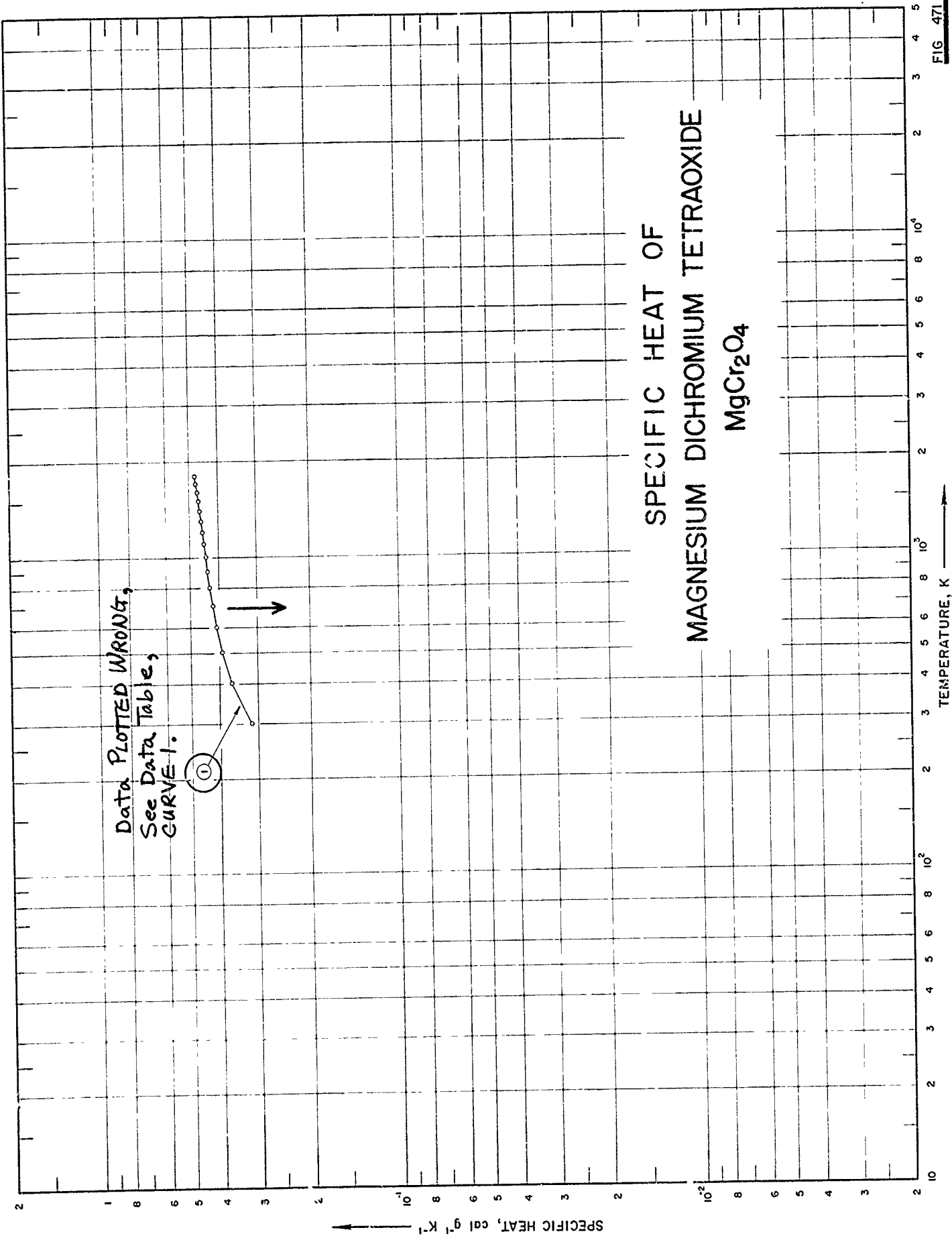

FIG 471

SPECIFICATION TABLE NO. 471 SPECIFIC HEAT OF MAGNESIUM DICHRONIUM TETRAOXIDE, $MgCr_2O_4$

[For Data Reported in Figure and Table No. 471]

Curve No.	Ref. No.	Year	Temp. Range, K	Reported Error, %	Name and Specimen Designation	Composition (weight percent), Specifications and Remarks
1	386	1944	298-1800	0.3		54.05 Cr, 12.58 Mg, 0.14 Fe; prepared by reacting reagent-grade MgO and Cr_2O_3 at 1400 C.

DATA TABLE NO. 471 SPECIFIC HEAT OF MAGNESIUM DICHRONIUM TETRAOXIDE MgCr_2O_4
 [Temperature, T, K; Specific Heat, C_p , Cal $\text{g}^{-1}\text{K}^{-1}$]

T	C_p
<u>CURVE 1</u>	
298	1.58×10^{-1}
300	1.58*
400	1.84
500	1.97
600	2.05
700	2.11
800	2.15
900	2.19
1000	2.22
1100	2.24
1200	2.27
1300	2.29
1400	2.31
1500	2.34
1600	2.36
1700	2.38
1800	2.40

* Not shown on plot

SPECIFIC HEAT OF MAGNESIUM DIIRON TETRAOXIDE $MgFe_2O_4$

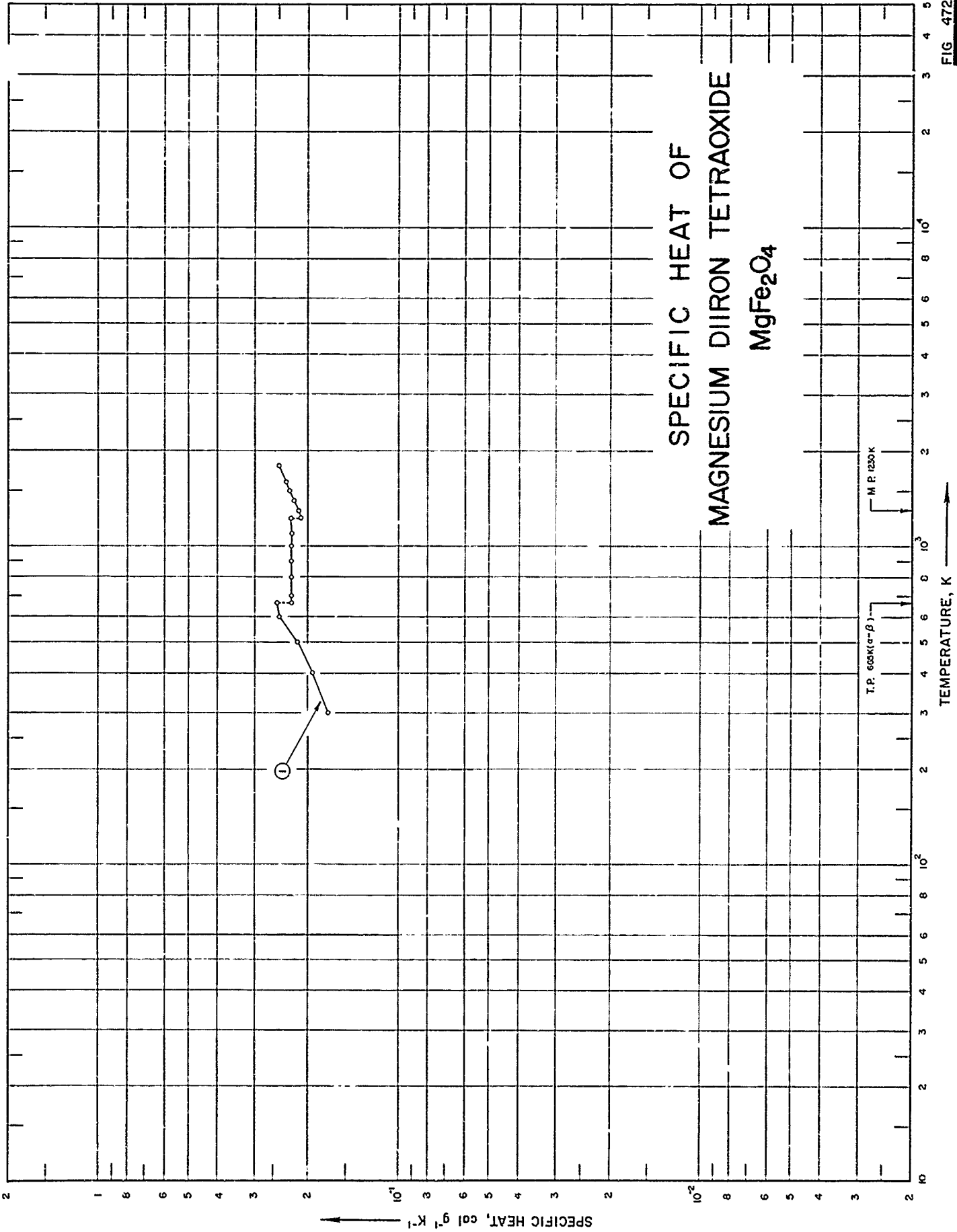

SPECIFICATION TABLE NO. 472 SPECIFIC HEAT OF MAGNESIUM DHYDRON TETRAOXIDE $MgFe_2O_4$

[For Data Reported in Figure and Table No. 472]

Curve No.	Ref. No.	Year	Temp. Range, K	Reported Error, %	Name and Specimen Designation	Composition (weight percent), Specifications and Remarks
1	367	1959	298-1800	0.1-1.2		79.74 Fe_2O_3 , 20.22 MgO (79.48, 20.16 theo.), 0.14 SiO_2 ; prepared from reagent-grade Fe_2O_3 and MgO ; heated repeated 900-1300 C; material analyzed and composition adjusted between heatings.

DATA TABLE NO. 472 SPECIFIC HEAT OF MAGNESIUM DIURON TETRAOXIDE $MgFe_2O_4$ [Temperature, T, K; Specific Heat, C_p , Cal $g^{-1}K^{-1}$]

T	C_p
CURVE 1	
298	1.72×10^{-1}
300	1.72
400	1.94
500	2.17
600	2.49
665	2.53
β 665	2.27
700	2.27
800	2.27
900	2.27
1000	2.27
1100	2.27
1200	2.27*
β 1230	2.27
γ 1230	2.12
1300	2.16
1400	2.23
1500	2.30
1600	2.37
1800	2.50

* Not shown on plot

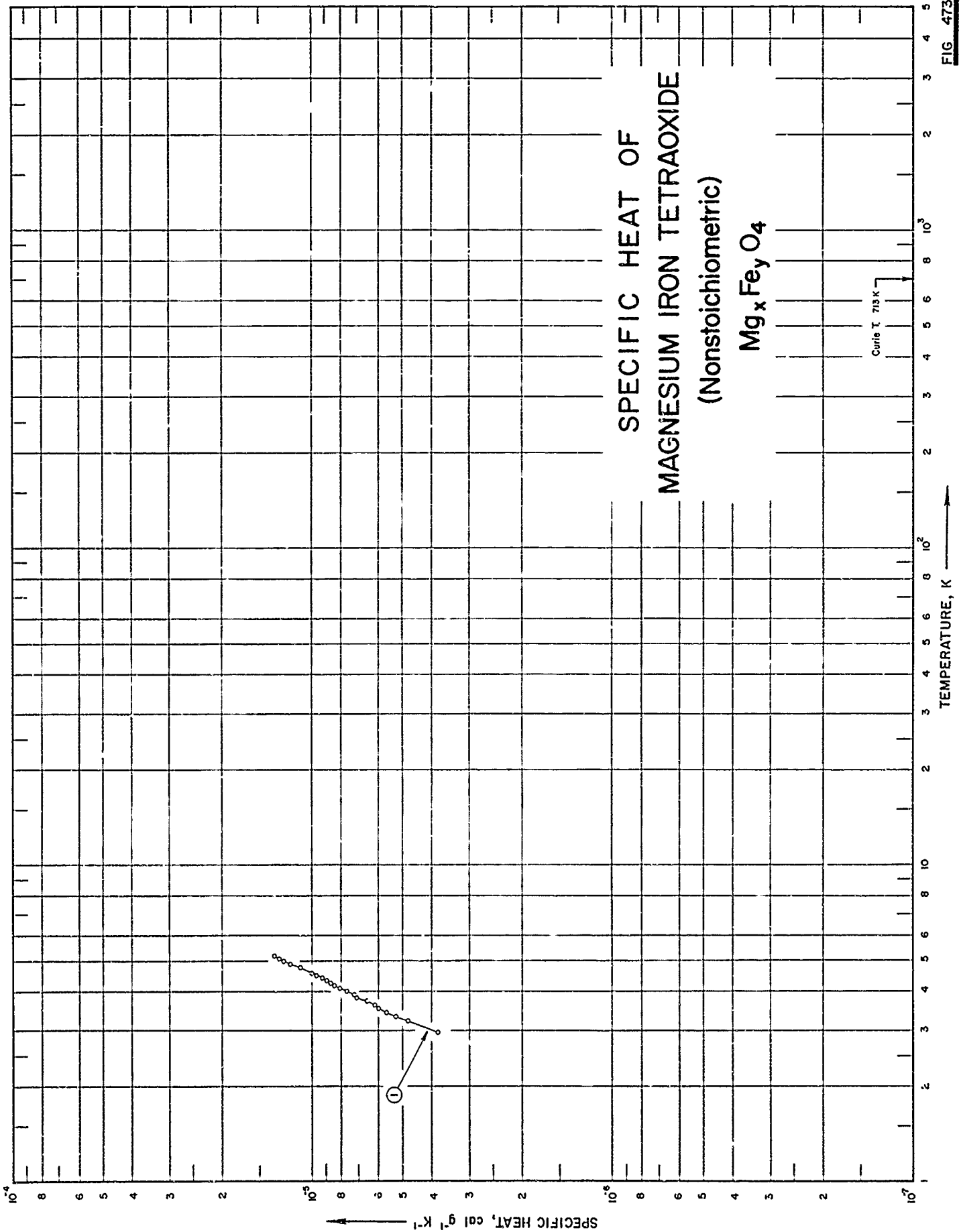

FIG. 473

SPECIFICATION TABLE NO. 473 SPECIFIC HEAT OF MAGNESIUM IRON TETRAOXIDE (nonstoichiometric) $Mg_xFe_yO_4$

[For Data Reported in Figure and Table No. 473]

Curve No.	Ref. No.	Year	Temp. Range, K	Reported Error, %	Name and Specimen Designation	Composition (weight percent), Specifications and Remarks
1	383	1961	3.0-5.2		$Mg_{0.8}Fe_{2.2}O_4$	58.43 Fe, 9.79 Mg; x-ray density = 4.65 g cm ⁻³ ; x-ray lattice parameter = 8.36 Å; Curie temperature = 713 K.

DATA TABLE NO. 473 SPECIFIC HEAT OF MAGNESIUM IRON TETRAOXIDE $Mg_xFe_yO_4$ (nonstoichiometric)
 [Temperature, T, K; Specific Heat, C_p , Cal $g^{-1}K^{-1}$]

T	C_p
CURVE 1	
2.978	3.826×10^{-6}
3.228	4.848
3.344	5.278
3.448	5.699
3.547	6.044
3.642	6.200
3.734	6.616
3.830	7.164
3.921	7.292
4.019	7.731
4.100	8.100
4.178	8.473
4.257	8.723
4.346	8.979
4.411	9.295
4.487	9.730
4.559	1.019×10^{-5}
4.761	1.111
4.874	1.196
4.965	1.265
5.087	1.309
5.184	1.358

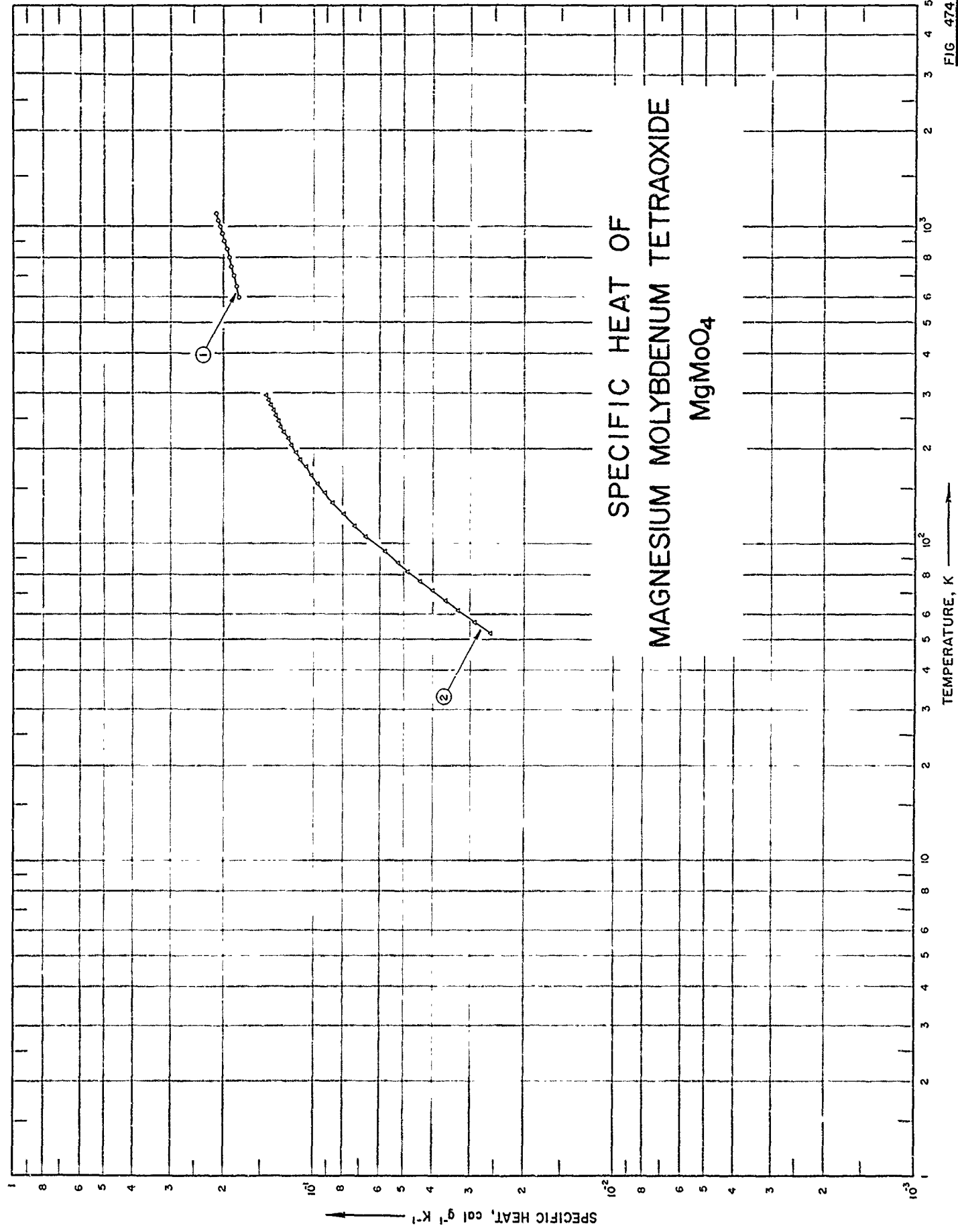

SPECIFICATION TABLE NO. 474 SPECIFIC HEAT OF MAGNESIUM MOLYBDENUM TETRAOXIDE $MgMoO_4$

[For Data Reported in Figure and Table No. 474]

Curve No.	Ref. No.	Year	Temp. Range, K	Reported Error, %	Name and Specimen Designation	Composition (weight percent), Specifications and Remarks
1	391	1961	600-1100	± 0.1		
2	368	1963	52-296	0.3		78.21 MoO_3 , 21.95 MgO ; prepared by dissolving stoichiometric amounts of reagent-grade MgO and MoO_3 in boiling water; heated to dryness at 122 C; heated at 870-890 C for 20 hrs.

DATA TABLE NO. 474 SPECIFIC HEAT OF MAGNESIUM MOLYBDENUM TETRAOXIDE MgMoO_4
 [Temperature, T.K.; Specific Heat, C_p , Cal $\text{g}^{-1}\text{K}^{-1}$]

T	C_p
<u>CURVE 1</u>	
600	1.777×10^{-1}
650	1.812
700	1.846
750	1.880
800	1.914
850	1.948
900	1.983
950	2.017
1000	2.051
1050	2.085
1100	2.119
<u>CURVE 2</u>	
52.43	2.587×10^{-2}
56.74	2.905
61.52	3.287
66.21	3.640
71.11	4.009
76.27	4.414
81.88	4.850
87.03	5.240
94.85	5.770
106.69	6.698
114.94	7.279
124.69	7.924
135.80	8.614
145.69	9.173
155.47	9.694
165.82	1.020×10^{-1}
176.21	1.066
185.94	1.113
195.97	1.147
206.43	1.185
216.44	1.219
226.36	1.252
236.19	1.285
245.70	1.313
256.47	1.342
266.73	1.368
276.61	1.395
286.80	1.417
296.39	1.439

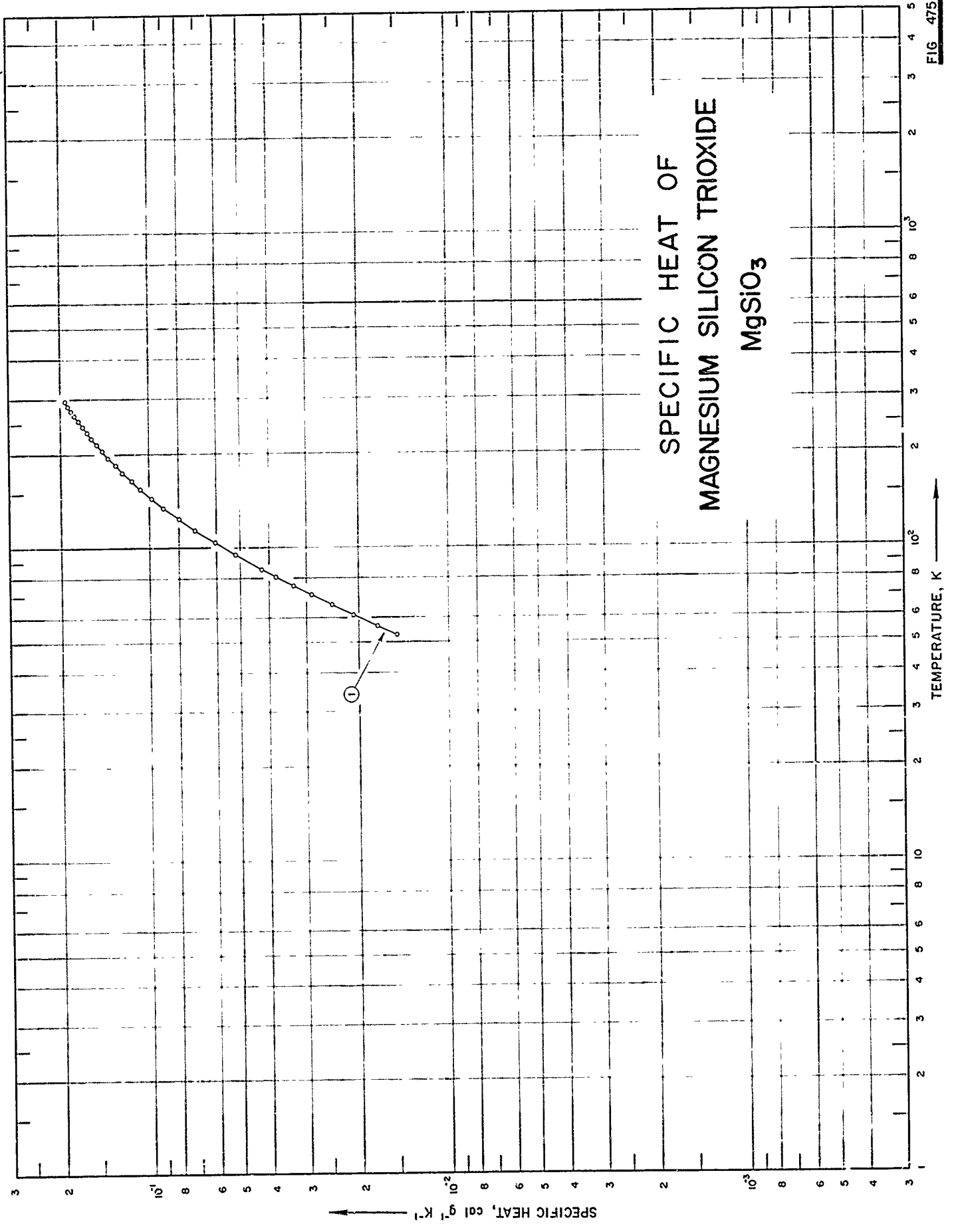

FIG. 475

SPECIFICATION TABLE NO. 475 SPECIFIC HEAT OF MAGNESIUM SILICON TRIOXIDE $MgSiO_3$

[For Data Reported in Figure and Table No. 475]

Curve No.	Ref. No.	Year	Temp. Range, K	Reported Error, %	Name and Specimen Designation	Composition (weight percent), Specifications and Remarks
1	392	1943	53-295			92.0 $MgSiO_3$, 5.6 Mg_2SiO_4 , 2.4 uncombined silica; corrected for uncombined silica.

DATA TABLE NO. 475 SPECIFIC HEAT OF MAGNESIUM SILICON TRIOXIDE $MgSiO_3$ [Temperature, T, K; Specific Heat, C_p , Cal $g^{-1}K^{-1}$]

T	C_p
	CURVE 1
52.7	1.502×10^{-2}
56.5	1.750
61.1	2.100
65.7	2.484
70.6	2.910
75.5	3.353
80.6	3.827
85.4	4.278
95.1	5.222
104.7	6.140
114.9	7.144
124.5	8.059
135.3	9.075
145.2	9.944
155.4	1.082×10^{-1}
165.5	1.167
176.7	1.251
185.8	1.318
195.9	1.394
206.2	1.461
215.9	1.523
226.2	1.589
236.3	1.645
246.1	1.704
256.4	1.755
266.3	1.803
276.3	1.864
285.9	1.901
295.3	1.938

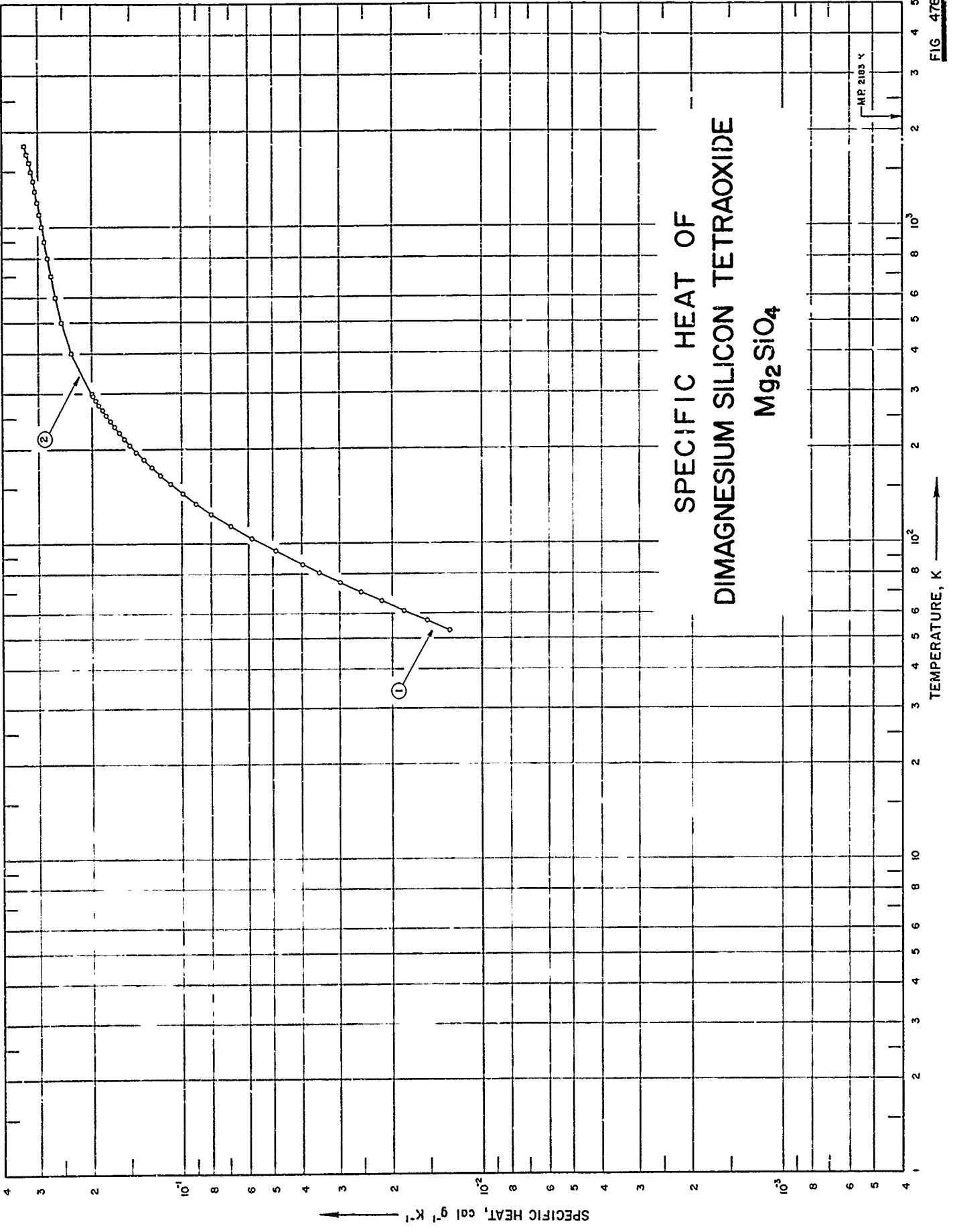

SPECIFICATION TABLE NO. 476 SPECIFIC HEAT OF DIMAGNESIUM SILICON TETRAOXIDE Mg_2SiO_4

[For Data Reported in Figure and Table No. 476]

Curve No.	Ref. No.	Year	Temp. Range, K	Reported Error, %	Name and Specimen Designation	Composition (weight percent), Specifications and Remarks
1	392	1943	53.2-295			98.6 Mg_2SiO_4 , 0.8 uncombined MgO, no free silica or $MgSiO_3$; corrected for uncombined MgO.
2	388	1953	298-1808			57.51 MgO, 42.60 SiO_2 .

DATA TABLE NO. 476 SPECIFIC HEAT OF DIMAGNESIUM SILICON TETRAOXIDE Mg_2SiO_4 Temperature, T, K; Specific Heat, C_p , Cal $g^{-1}K^{-1}$

T	C_p		T	C_p
	CURVE 1	CURVE 2 (cont.)		
53.2	1.291×10^2		1500	3.21×10^1
57.3	1.541		1600	3.26
61.4	1.816		1700	3.31
65.6	2.182		1800	3.36
70.0	2.564		1808	3.37
75.0	3.002			
80.6	3.528			
85.5	4.006			
94.7	4.939			
104.3	5.930			
114.4	6.978			
124.8	8.067			
134.7	9.669			
145.3	1.009×10^1			
155.8	1.105			
165.6	1.193			
175.9	1.277			
185.7	1.355			
196.3	1.437			
206.0	1.505			
216.2	1.574			
226.0	1.637			
236.0	1.695			
246.3	1.758			
256.1	1.810			
266.4	1.862			
276.3	1.920			
286.0	1.962			
295.0	1.994			
CURVE 2				
298	2.00×10^{-2}			
309	2.01			
400	2.35			
500	2.53			
600	2.66			
700	2.75			
800	2.82			
900	2.89			
1000	2.95			
1100	3.01			
1200	3.06			
1300	3.11			
1400	3.16			

* Not shown on plot

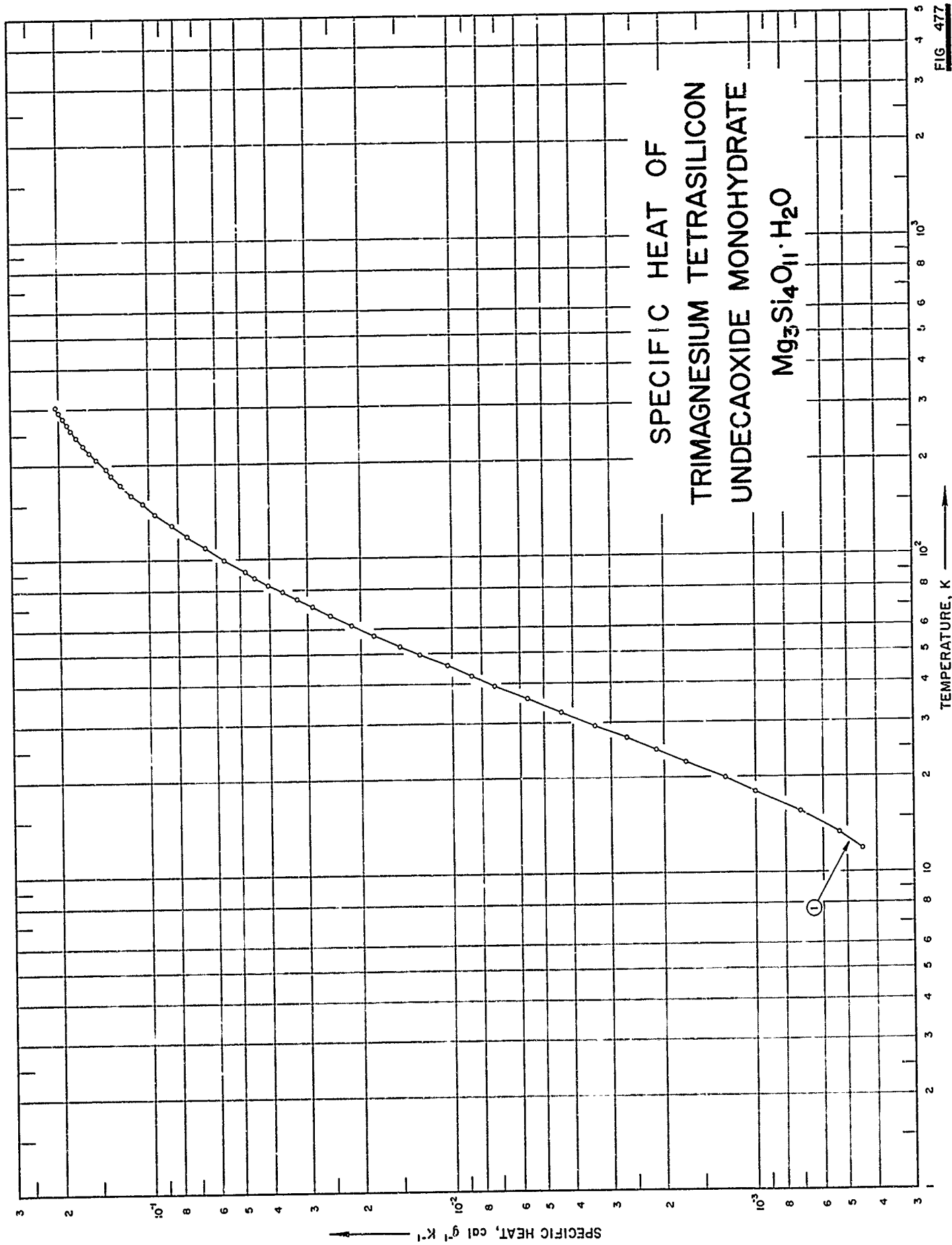

FIG 477

SPECIFICATION TABLE NO. 477 SPECIFIC HEAT OF TRIMAGNESIUM TETRASILICON UNDECAOXIDE MONOHYDRATE $Mg_3Si_4O_{11} \cdot H_2O$

[For Data Reported in Figure and Table No. 477]

Curve No.	Ref. No.	Year	Temp. Range, K	Reported Error, %	Name and Specimen Designation	Composition (weight percent). Specifications and Remarks
1	381	1963	53-306	0.3	Talc	62.47 SiO ₂ , 31.76 MgO, 4.70 H ₂ O [*] , 0.47 Al ₂ O ₃ , 0.45 FeO, 0.06 H ₂ O ⁻ ; dried at 115 C for 12 hrs.

DATA TABLE NO. 477 SPECIFIC HEAT OF TRIMAGNESIUM TETRASILICON UNDECAOXIDE MONOHYDRATE $Mg_3Si_4O_{11} \cdot H_2O$

[Temperature, T, K; Specific Heat, C_p , Cal $g^{-1}K^{-1}$]

T	C_p	T	C_p
	CURVE I		CURVE I (cont.)
	Series I		Series I (cont.)
52.74	1.502×10^{-2}	288.11	1.982×10^{-2a}
57.48	1.838	294.38	2.010
61.89	2.174	299.39	2.026*
66.37	2.540	299.96	2.033*
70.78	2.911	306.45	2.055
74.92	3.275		
79.12	3.667	Series II	
83.44	4.079	11.85	4.456×10^{-4}
87.88	4.508	13.45	5.318
91.53	4.856	15.61	7.124
95.61	5.236^*	18.12	1.005×10^{-3}
99.95	5.674	20.02	1.272
104.20	6.085^*	22.45	1.706
108.98	6.557	24.60	2.141
113.89	7.042*	26.79	2.676
118.71	7.519	29.41	3.404
123.84	8.026^*	32.43	4.411
128.80	8.495	35.83	5.726
134.24	9.022^*	39.47	7.343
140.30	9.608	42.34	8.737
146.33	1.015×10^{-3a}	45.71	1.059×10^{-2}
151.93	1.065	45.73	1.058*
156.29	1.102*	49.71	1.300
161.86	1.151	53.71	1.567*
168.14	1.205*	81.33	3.878*
174.44	1.258		
180.54	1.305*		
186.28	1.350		
190.45	1.382*		
196.15	1.394		
202.23	1.469*		
208.68	1.514		
214.91	1.557*		
219.56	1.587		
225.37	1.625^*		
230.89	1.661		
235.24	1.694*		
238.53	1.710*		
245.27	1.751		
251.56	1.786*		
257.81	1.824		
263.47	1.856*		
269.25	1.887		
274.77	1.917*		
281.54	1.949		

* Not shown on plot

SPECIFIC HEAT OF
DIMAGNESIUM TETRAALUMINUM
PENTASILICON I8-OXIDE
 $Mg_2 Al_4 Si_5 O_{18}$

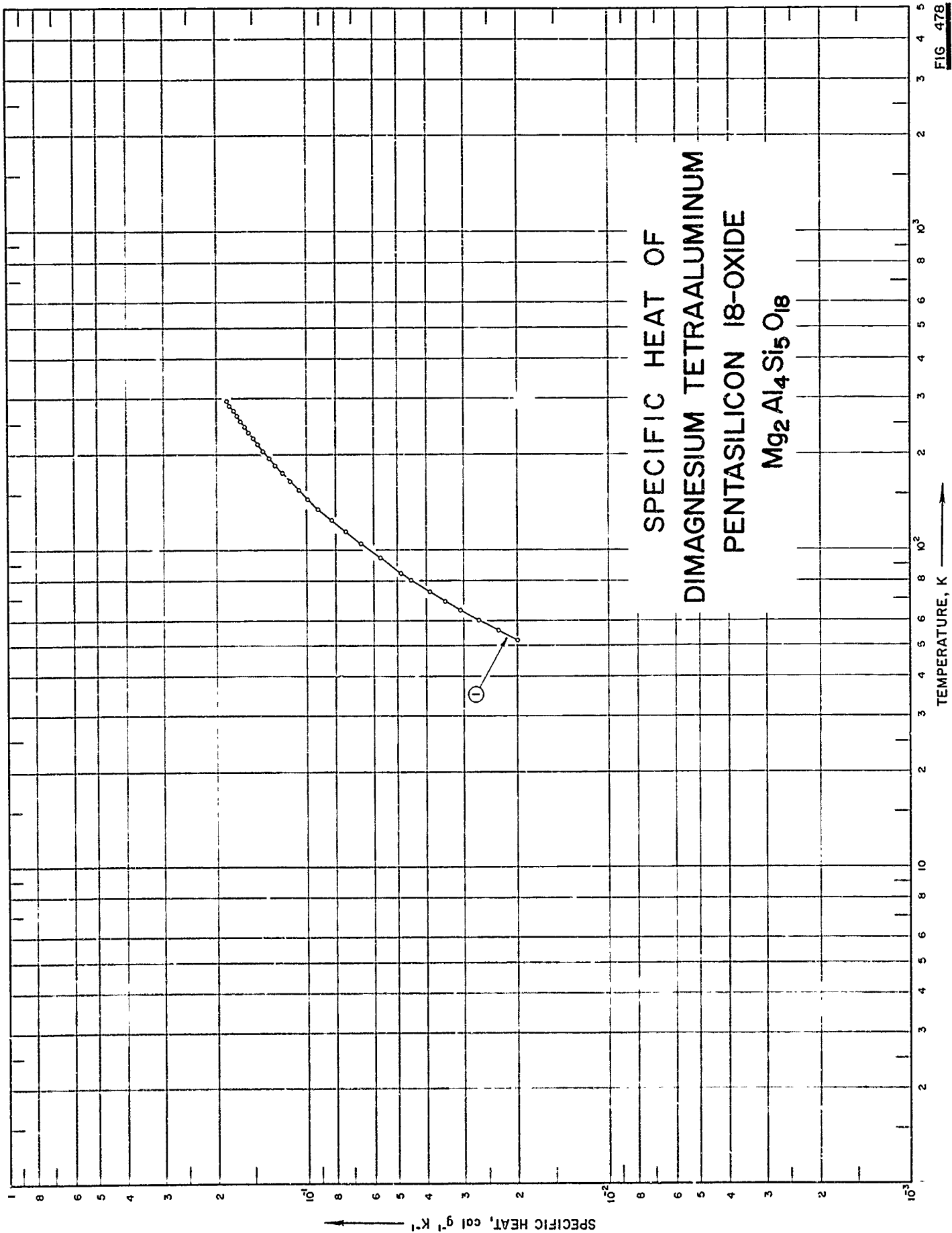

SPECIFICATION TABLE NO. 478 SPECIFIC HEAT OF DIMAGNESIUM TETRAALUMINUM PENTASILICON 18-OXIDE $Mg_2Al_4Si_5O_{18}$

[For Data Reported in Figure and Table No. 478]

Curve No.	Ref. No.	Year	Temp. Range, K	Reported Error, %	Name and Specimen Designation	Composition (weight percent), Specifications and Remarks
1	379	1963	52-296	0.3	Cordierite	50.97 SiO ₂ , 35.45 Al ₂ O ₃ , 13.74 MgO.

DATA TABLE NO. 478 SPECIFIC HEAT OF DIMAGNESIUM TETRAALUMINUM PENTASILICON 18-OXIDE $Mg_2Al_4Si_5O_{18}$ [Temperature, T, K; Specific Heat, C_p , Cal $g^{-1}K^{-1}$]

T	C_p
CURVE 1	
51.83	1.997×10^{-2}
55.67	2.391
59.93	2.677
64.50	3.078
69.27	3.482
74.06	3.910
80.65	4.506
84.87	4.872
94.58	5.713
105.08	6.636
114.50	7.433
124.46	8.260
135.82	9.173
145.73	9.922
155.99	1.070×10^{-1}
165.87	1.139
176.04	1.207
186.05	1.274
195.81	1.333
206.60	1.397
216.16	1.451
225.83	1.506
235.90	1.561
245.71	1.612
256.30	1.663
266.25	1.708
276.34	1.754
286.81	1.802
296.41	1.841

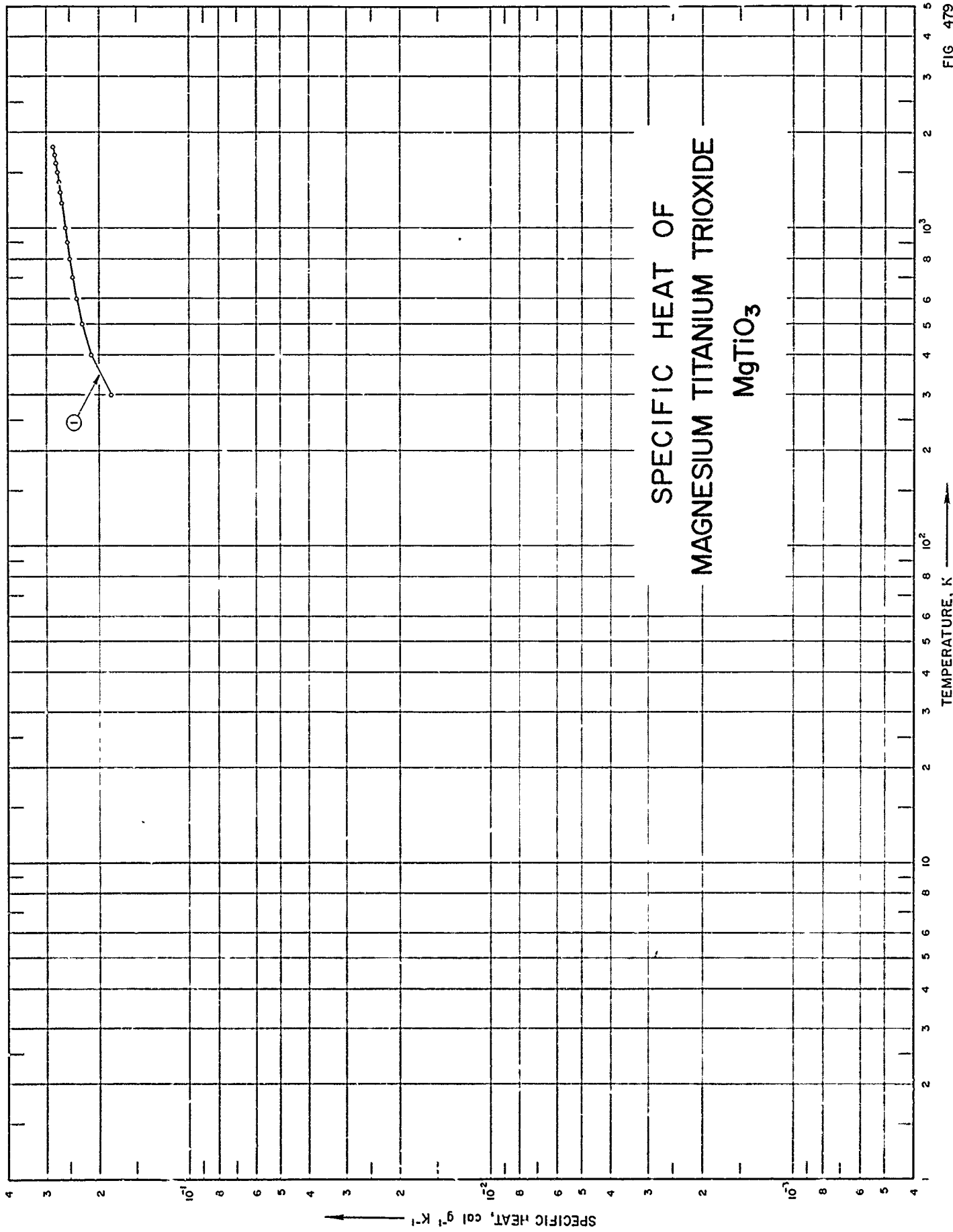

FIG. 479

SPECIFICATION TABLE NO. 479 SPECIFIC HEAT OF MAGNESIUM TITANIUM TRIOXIDE $MgTiO_3$

[For Data Reported in Figure and Table No. 479]

Curve No.	Ref. No.	Year	Temp. Range, K	Reported Error, %	Name and Specimen Designation	Composition (weight percent), Specifications and Remarks
1	374	1946	298-1800			99.0 $MgTiO_3$, 0.45 MgO.

DATA TABLE NO. 479 SPECIFIC HEAT OF MAGNESIUM TITANIUM TRIOXIDE $MgTiO_3$
[Temperature, T, K; Specific Heat, C_p , Cal $g^{-1}K^{-1}$]

T	C_p
<u>CURVE 1</u>	
298	1.82×10^{-1}
300	1.83*
400	2.12
500	2.27
600	2.37
700	2.43
800	2.49
900	2.53
1000	2.57
1200	2.64
1300	2.68
1400	2.71
1500	2.74
1600	2.77
1700	2.80
1800	2.83

* Not shown on plot

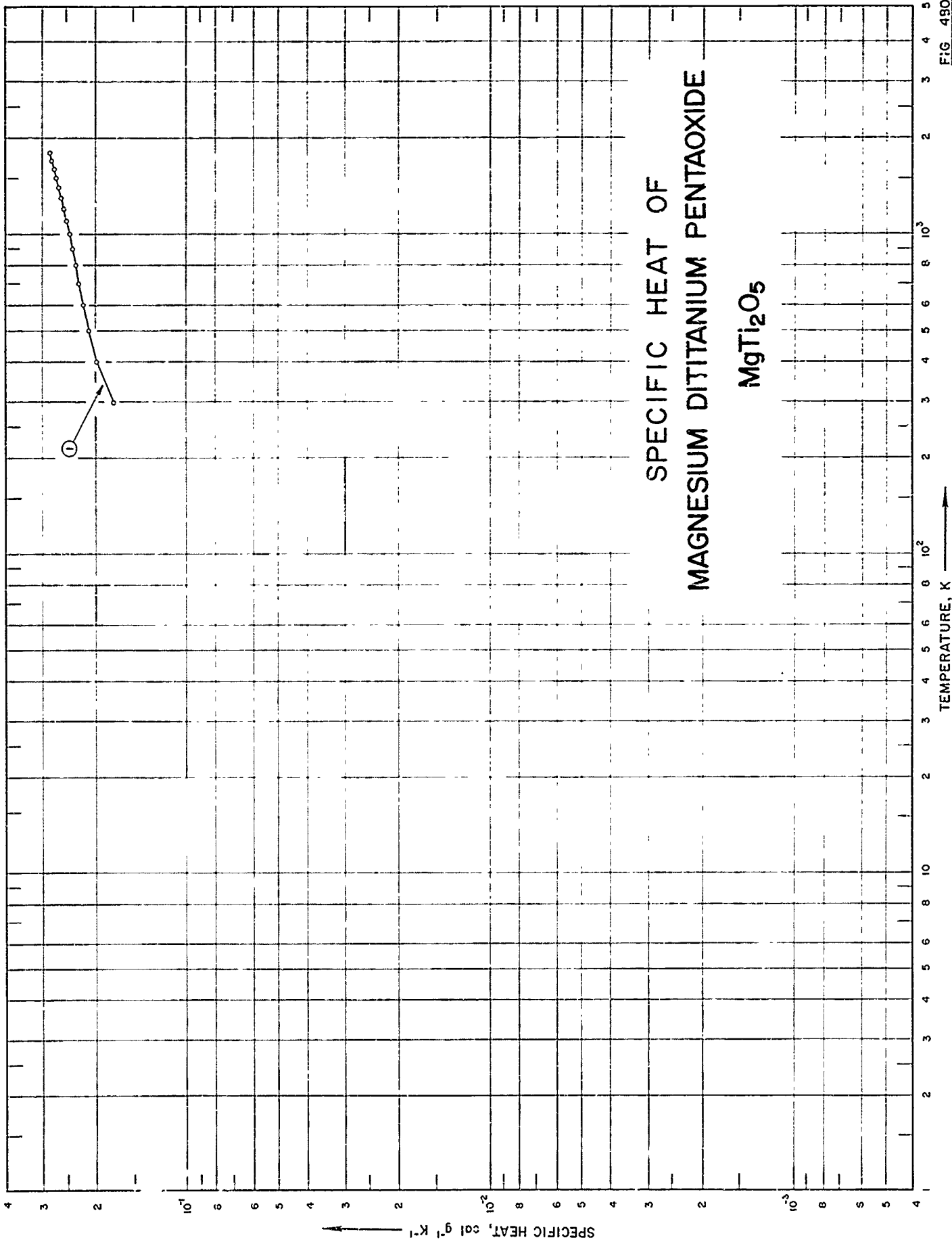

SPECIFICATION TABLE NO. 480 SPECIFIC HEAT OF MAGNESIUM DITITANIUM PENTAOXIDE $MgTi_2O_5$

[For Data Reported in Figure and Table No. 480]

Curve No.	Ref. No.	Year	Temp. Range, K	Reported Error, %	Name and Specimen Designation	Composition (weight percent), Specifications and Remarks
1	393	1952	298-1800	0.5 in ΔH		79.63 TiO_2 (79.85 theo.), 0.16 TiO_3 ; oxides mixed, pressed at 15,000 psi, and heated for long periods at 1300-1500 C.

DATA TABLE NO. 480 SPECIFIC HEAT OF MAGNESIUM DITITANIUM PENTAOXIDE $MgTi_2O_5$ [Temperature, T, K; Specific Heat, C_p , Cal $g^{-1}K^{-1}$]

T	C_p
CURVE 1	
298.15	1.76×10^{-1}
300	1.76*
400	1.99
500	2.12
600	2.21
700	2.28
800	2.34
900	2.40
1000	2.46
1100	2.51
1200	2.56
1300	2.61
1400	2.66
1500	2.71
1600	2.75
1700	2.80
1800	2.85

* Not shown on plot

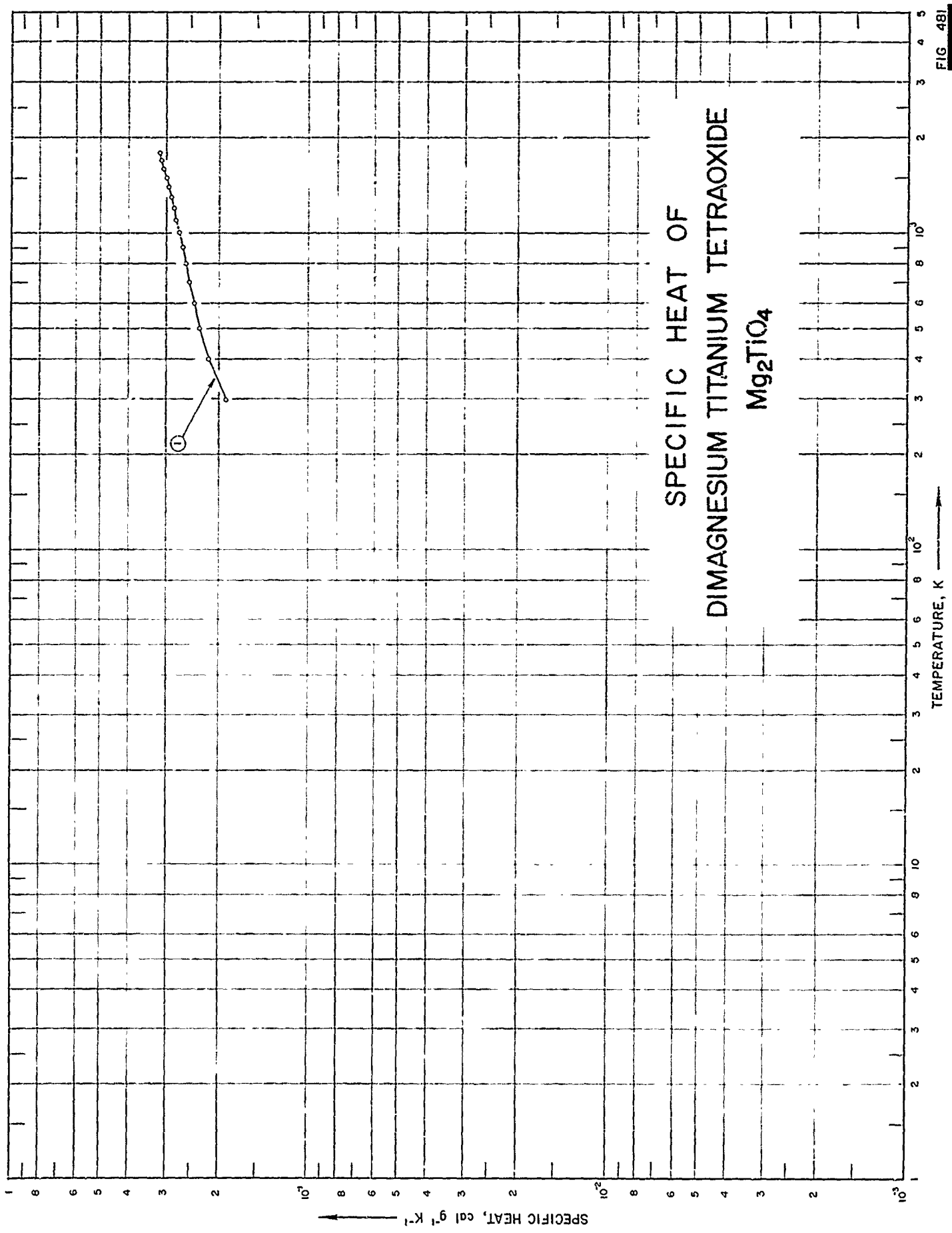

FIG 481

SPECIFICATION TABLE NO. 481 SPECIFIC HEAT OF DIMAGNESIUM TITANIUM TETRAOXIDE Mg_2TiO_4

[For Data Reported in Figure and Table No. 481]

Curve No.	Ref. No.	Year	Temp. Range, K	Reported Error, %	Name and Specimen Designation	Composition (weight percent). Specifications and Remarks
1	393	1952	298-1800	0.5 in ΔH		49.53 TiO_2 (49.77 theo.), 0.21 SiO_2 ; oxides were mixed, pressed at 15,000 psi, and heated for long periods at 1300-1500 C.

DATA TABLE NO. 481 SPECIFIC HEAT OF DIMAGNESIUM TITANIUM TETRAOXIDE Mg_2TiO_4
 [Temperature, T, K; Specific Heat, C_p , Cal $g^{-1}K^{-1}$]

T	C_p
	CURVE 1
298	1.92×10^{-1}
300	1.92*
400	2.18
500	2.33
600	2.44
700	2.52
800	2.60
900	2.67
1000	2.73
1100	2.79
1200	2.85
1300	2.91
1400	2.96
1500	3.02
1600	3.07
1700	3.13
1800	3.18

* Not shown on plot

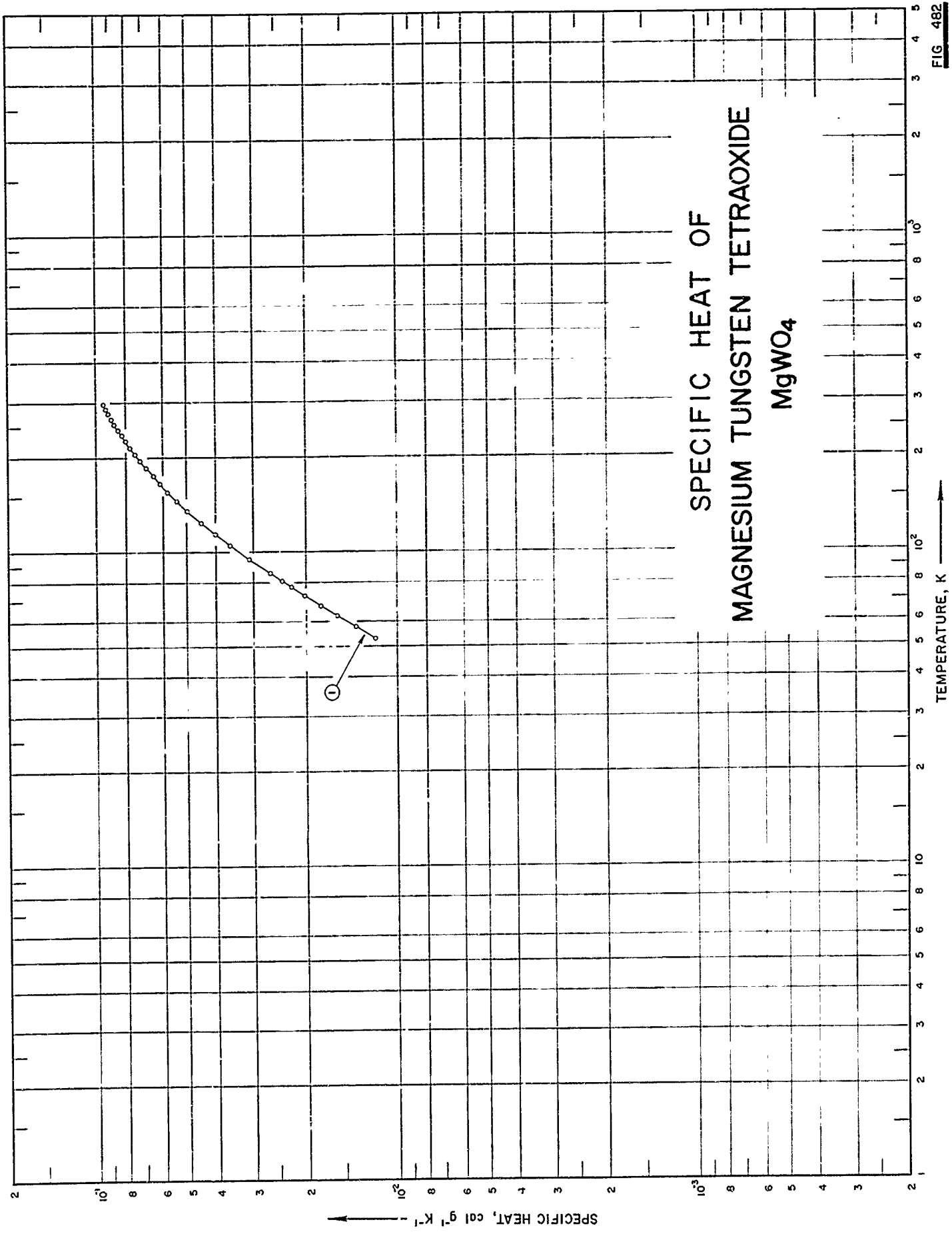

SPECIFICATION TABLE NO. 482 SPECIFIC HEAT OF MAGNESIUM TUNGSTEN TETRAOXIDE $MgWO_4$

[For Data Reported in Figure and Table No. 482]

Curve No.	Ref. No.	Year	Temp. Range, K	Reported Error, %	Name and Specimen Designation	Composition (weight percent)	Specifications and Remarks
1	383	1961	53-296	0.3		85.24 WO_3 , 14.79 MgO , prepared by heating stoichiometric mixture of reagent-grade magnesia and tungstic acid 8 times for total of 5 days at 900 C.	

DATA TABLE NO. 482 SPECIFIC HEAT OF MAGNESIUM TUNGSTEN TETRAOXIDE $MgWO_4$ [Temperature, T, K; Specific Heat, C_p , Cal $g^{-1}K^{-1}$]

T	C_p
CURVE 1	
52.92	1.181×10^{-2}
57.77	1.376
62.61	1.584
67.38	1.797
72.41	2.029
77.35	2.260
80.68	2.420
85.67	2.660
94.96	3.114
105.57	3.622
114.75	4.049
124.88	4.512
136.05	5.004
145.86	5.423
155.87	5.812
166.10	6.194
176.15	6.547
185.94	6.874
195.99	7.183
206.12	7.488
216.21	7.774
226.30	8.042
236.08	8.289
245.98	8.509
256.87	8.766
266.48	8.957
276.44	9.163
286.51	9.350
296.01	9.538

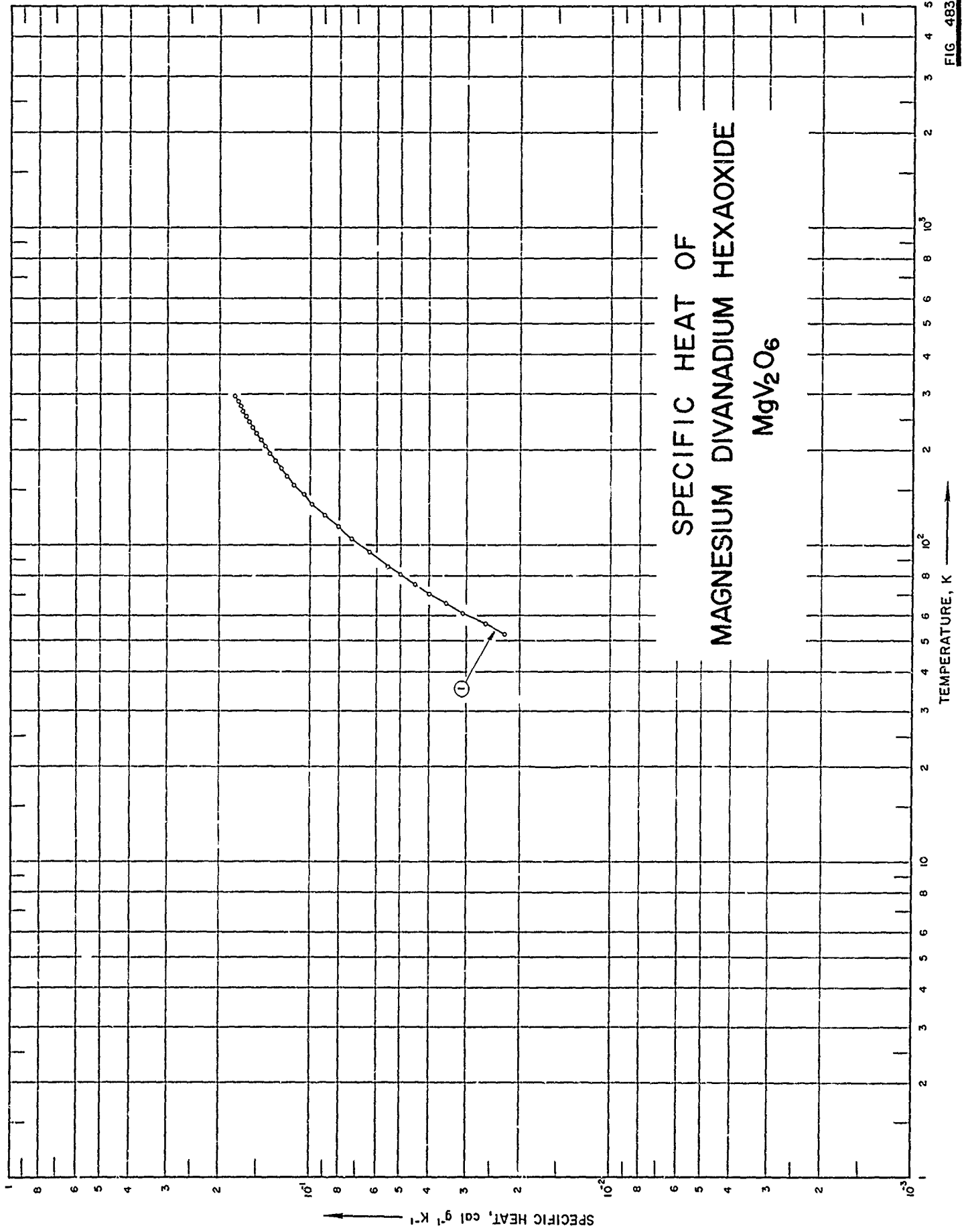

FIG 483

SPECIFICATION TABLE NO. 483 SPECIFIC HEAT OF MAGNESIUM DIVANADIUM HEXAOXIDE MgV_2O_6

[For Data Reported in Figure and Table No. 483]

Curve No.	Ref. No.	Year	Temp. Range, K	Reported Error, %	Name and Specimen Designation	Composition (weight percent), Specifications and Remarks
1	394	1962	53-296	0.3		99.9 MgV_2O_6 .

DATA TABLE NO. 483 SPECIFIC HEAT OF MAGNESIUM DIVANADIUM HEXAOXIDE MgV_2O_6 [Temperature, T, K; Specific Heat, C_p , Cal $g^{-1}K^{-1}$]

T	C_p
CURVE 1	
52.51	2.261×10^{-2}
56.75	2.596
61.30	3.103
65.79	3.534
70.42	4.016
75.24	4.460
80.92	5.018
86.24	5.500
95.01	6.364
104.97	7.282
114.51	8.070
124.63	8.988
135.89	9.883
145.61	1.059×10^{-1}
155.75	1.129
165.72	1.198
175.84	1.255
186.15	1.316
196.13	1.370
206.21	1.421
216.09	1.468
226.13	1.520
236.63	1.561
246.18	1.599
257.19	1.641
266.70	1.675
276.08	1.705
286.48	1.740
295.95	1.780

SPECIFIC HEAT OF
DIMAGNESIUM DIVANADIUM HEPTAOXIDE
 $Mg_2V_2O_7$

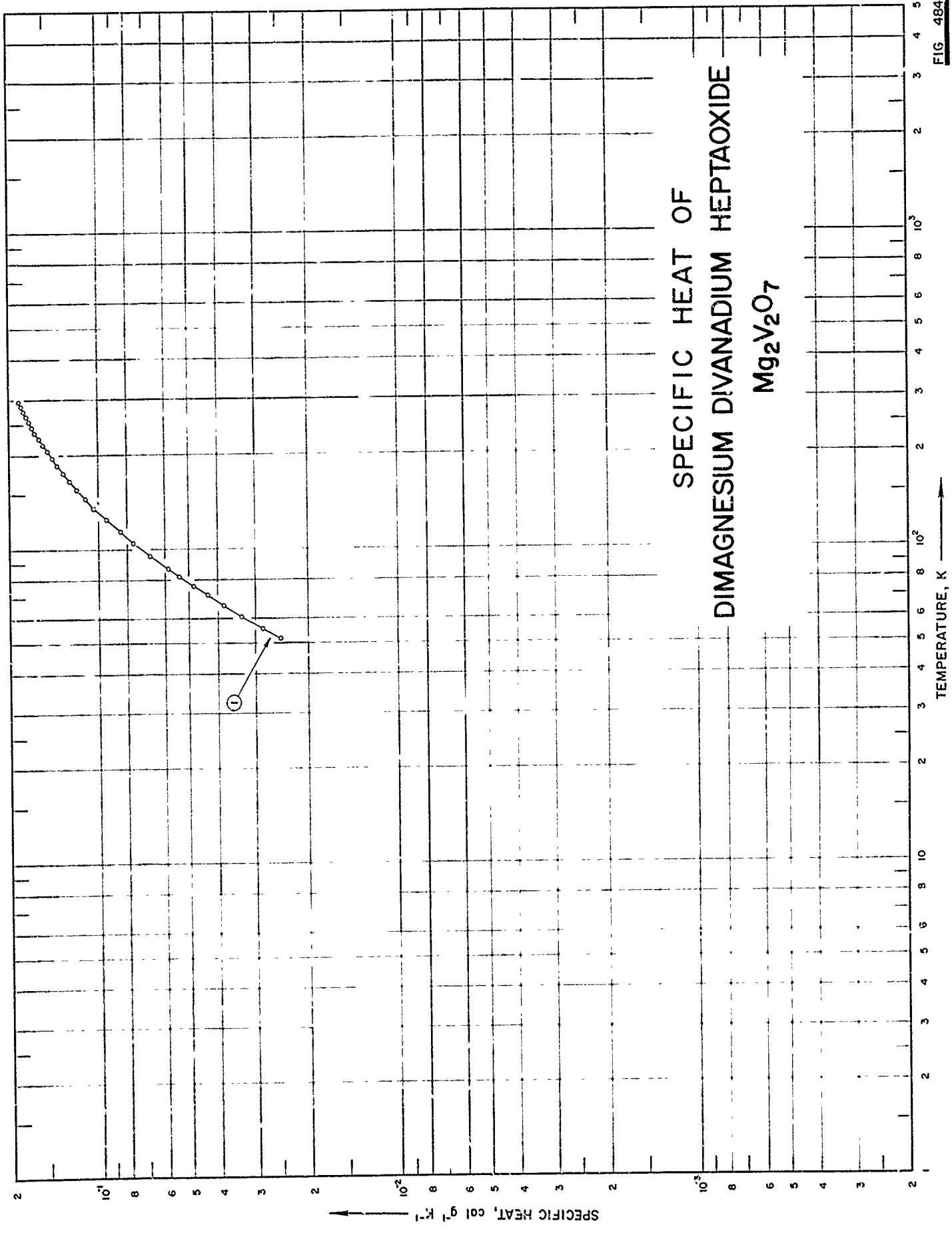

SPECIFICATION TABLE NO. 484 SPECIFIC HEAT OF DIMAGNESIUM DIVANADIUM HEPTAOXIDE $Mg_2V_2O_7$

[For Data Reported in Figure and Table No. 484]

Curve No.	Ref. No.	Year	Temp. Range, K	Reported Error, %	Name and Specimen Designation	Composition (weight percent), Specifications and Remarks
1	394	1962	52-296	0.3		99.9 $Mg_2V_2O_7$.

DATA TABLE NO. 484 SPECIFIC HEAT OF DIMAGNESIUM DIVANDIUM HEPTAOXIDE $Mg_2V_2O_7$ [Temperature, T, K. Specific Heat, C_p , Cal $g^{-1}K^{-1}$]

T	C_p
51.90	2.489×10^{-2}
55.83	2.851
60.84	3.356
66.00	3.855
71.21	4.354
76.24	4.865
81.62	5.406
86.52	5.882
94.87	6.777
105.08	7.672
114.77	8.476
124.58	9.448
136.61	1.046×10^{-1}
145.82	1.116
156.06	1.189
165.86	1.256
176.16	1.320
185.98	1.378
195.94	1.433
206.33	1.486
216.83	1.540
226.15	1.587
236.32	1.629
245.96	1.669
256.84	1.710
266.87	1.746
276.71	1.781
281.86	1.816
296.32	1.848

SPECIFIC HEAT OF
MANGANESE SILICON TRIOXIDE
 $MnSiO_3$

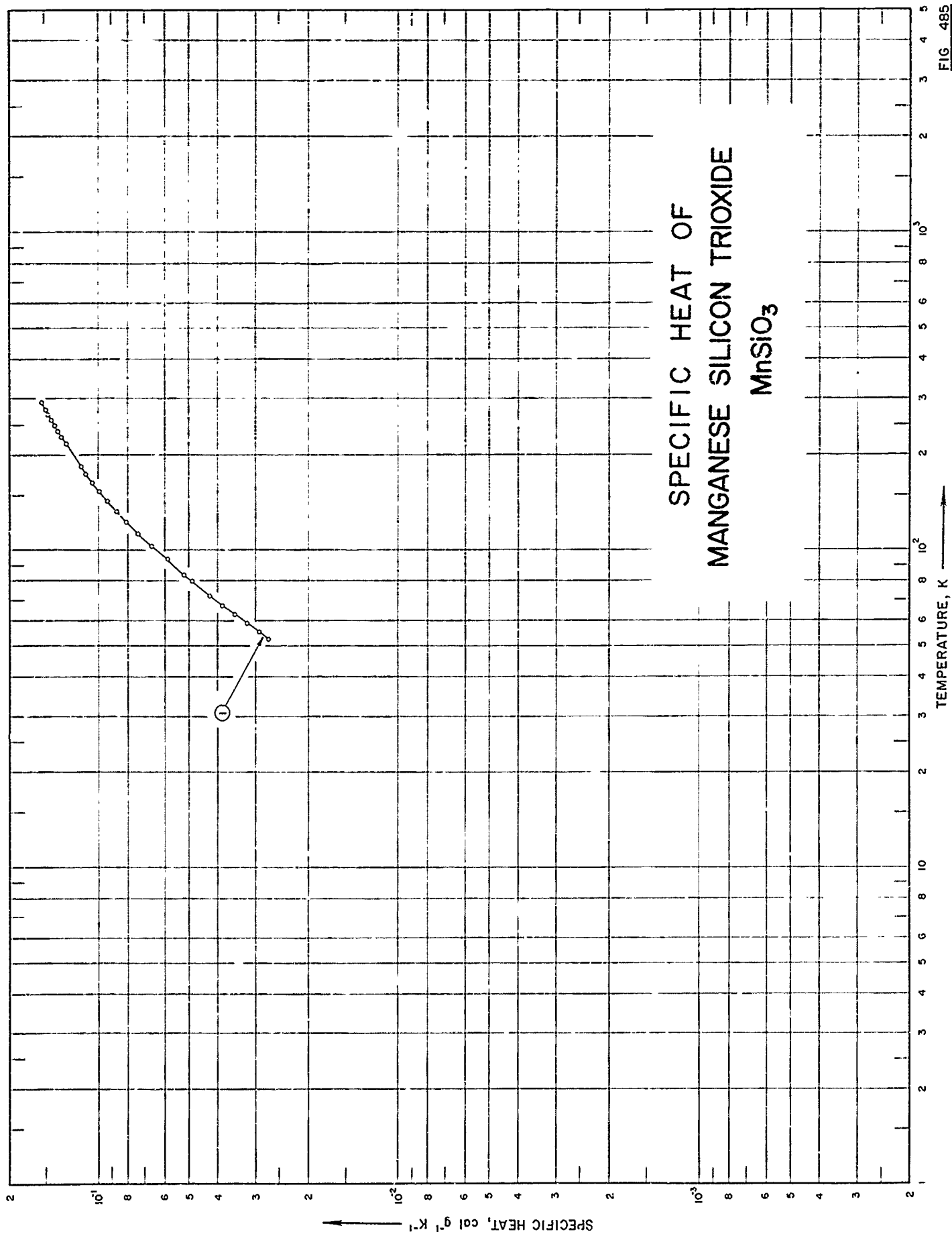

FIG 485

SPECIFICATION TABLE NO. 485 SPECIFIC HEAT OF MANGANESE SILICON TRIOXIDE MnSiO₃

[For Data Reported in Figure and Table No. 485]

Curve No.	Ref. No.	Year	Temp. Range, K	Reported Error, %	Name and Specimen Designation	Composition (weight percent), Specifications and Remarks
1	387	1941	53-295			54.18 MnO (54.15 theo.); density = 230 lb ft ⁻³ .

DATA TABLE NO. 485 SPECIFIC HEAT OF MANGANESE SILICON TRIOXIDE $MnSiO_3$ [Temperature, T, K; Specific Heat, C_p , Cal $g^{-1}K^{-1}$]

T	C_p
CURVE 1	
52.60	2.741×10^2
55.50	2.937
59.20	3.227
63.10	3.545
67.40	3.897
72.20	4.294
80.30	4.926
84.30	5.235
93.60	5.930
103.30	6.683
113.60	7.427
123.70	8.107
134.20	8.787
144.60	9.428
154.90	9.978
164.80	1.059×10^1
175.20	1.111
185.10	1.158
218.10	1.299
228.30	1.344
238.30	1.378
248.10	1.418
257.90	1.448
268.20	1.486
278.10	1.514
286.80	1.545*
294.80	1.567

* Not shown on plot

SPECIFIC HEAT OF
TRINEODYMIUM PENTAGALLIUM
DODECAOXIDE (Garnet)
 $Nd_3Ga_5O_{12}$

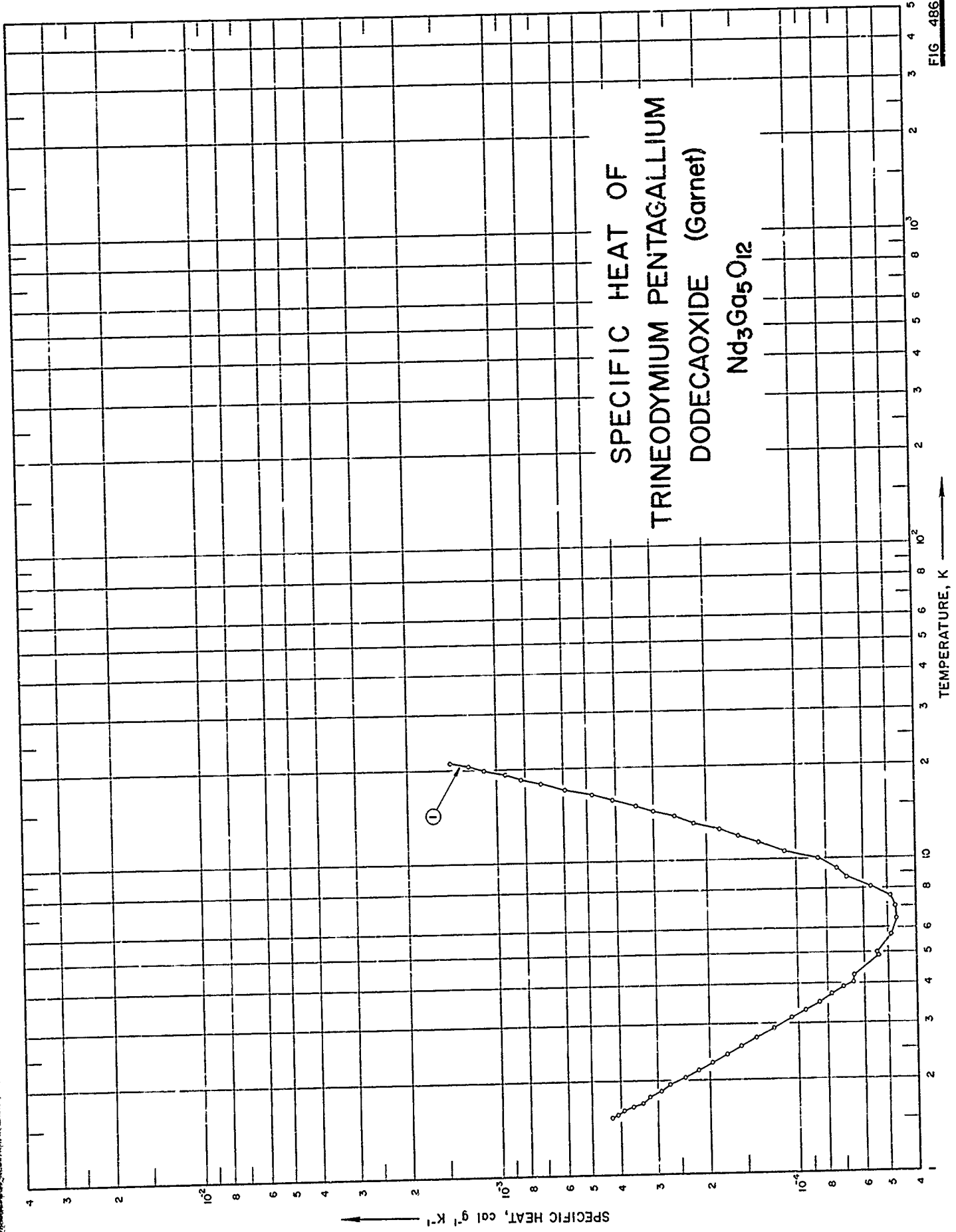

SPECIFICATION TABLE NO. 486 SPECIFIC HEAT OF TRINEODYMIUM PENTAGALLIUM DODECAOXIDE, $\text{Nd}_3\text{Ga}_5\text{O}_{12}$ (Garnet)

[For Data Reported in Figure and Table No. 486]

Curve No.	Ref. No.	Year	Temp. Range, K	Reported Error, %	Name and Specimen Designation	Composition (weight percent), Specifications and Remarks
1	449	1963	1.5-21		Garnet	99.99 Nd_2O_3 ; supplied by the Lindsay Chem. or Johnson, Matthey and Co.; 99.99 Ga_2O_3 ; supplied by Johnson, Matthey and Co.; direct solid state reaction of an intimate mixture of pure rare earth and gallium oxide; sintered block; polycrystalline.

DATA TABLE NO. 486 SPECIFIC HEAT OF TRINEODYMIUM PENTAGALLIUM DODECAOXIDE, $\text{Nd}_3\text{Ga}_5\text{O}_{12}$ (Garnet)
 [Temperature, T, K; Specific Heat, C_p , Cal $\text{g}^{-1}\text{K}^{-1}$]

T	C_p	T	C_p
	CURVE 1		CURVE 1 (cont.)
1.535	4.295×10^{-4}	19.29	9.350×10^{-4}
1.569	4.123	19.90	1.104×10^{-3}
1.612	3.902	20.56	1.247
1.655	3.657	21.14	1.433
1.699	3.387		
1.780	3.190		
1.853	2.920		
1.946	2.724		
2.037	2.425		
2.158	2.189		
2.273	1.963		
2.405	1.757		
2.556	1.571		
2.721	1.391		
2.905	1.215		
3.127	1.065		
3.313	9.473×10^{-5}		
3.561	8.540		
3.707	7.755		
3.903	7.068		
4.045	6.552		
4.25	6.503		
4.90	5.374		
5.00	5.424		
5.72	4.884		
6.42	4.687		
7.01	4.712		
7.57	4.894		
8.13	5.669		
8.70	6.798		
9.34	7.362		
10.01	8.491		
10.68	1.099×10^{-4}		
11.34	1.337		
11.99	1.563		
12.61	1.804		
13.22	2.201		
13.87	2.552		
14.48	3.019		
15.09	3.436		
15.74	4.123		
16.49	4.835		
17.16	5.914		
17.92	7.117		
18.55	8.270		

SPECIFIC HEAT OF
NICKEL DIIRON TETRAOXIDE
 NiFe_2O_4

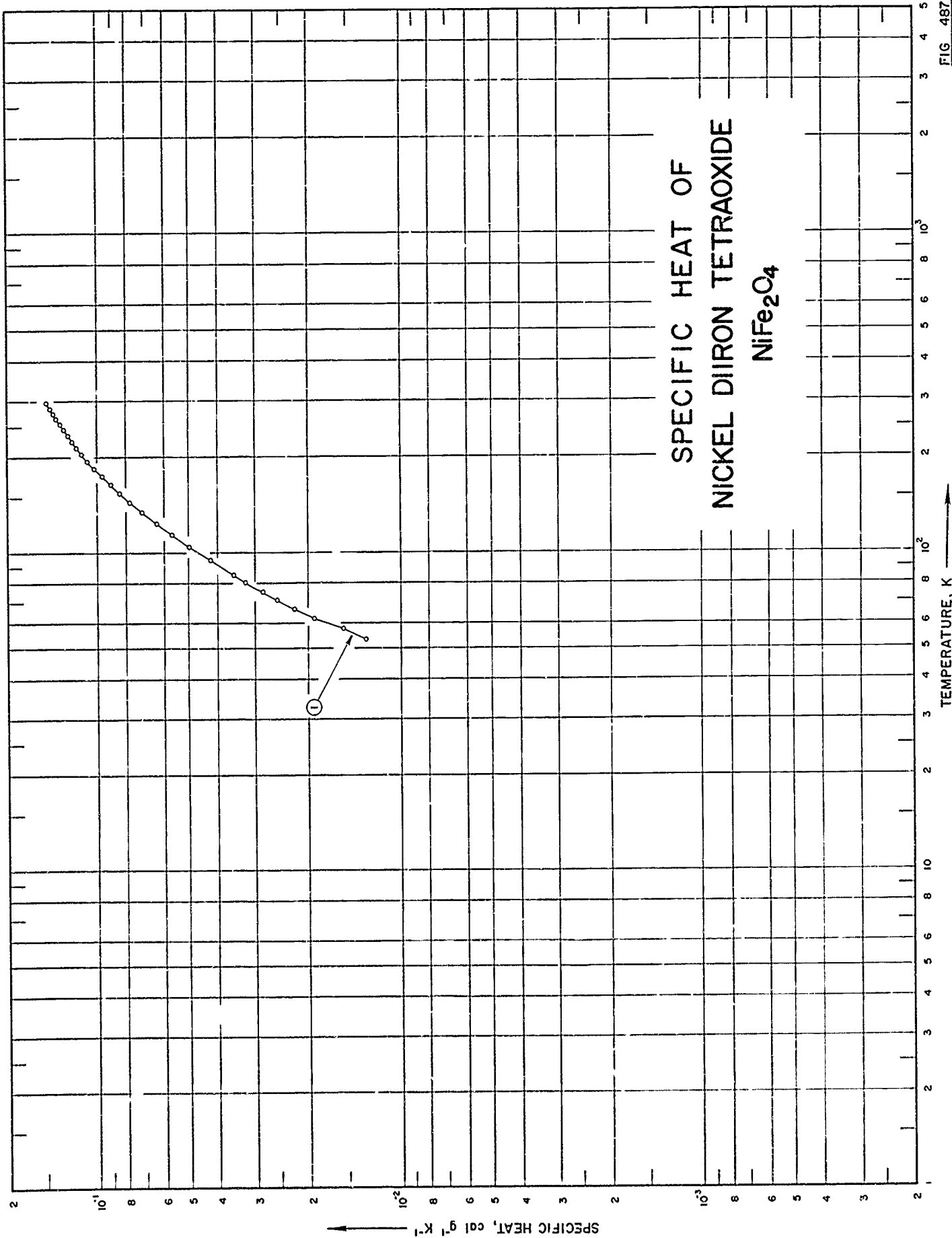

FIG 487

SPECIFICATION TABLE NO. 487 SPECIFIC HEAT OF NICKEL DIFERON TETRAOXIDE NiFe_2O_4

[For Data Reported in Figure and Table No. 487]

Curve No.	Ref. No.	Year	Temp. Range, K	Reported Error, %	Name and Specimen Designation	Composition (weight percent), Specifications and Remarks
1	382	1956	54-298		Nickel-iron spinel	68.11 Fe_2O_3 , 31.86 NiO (68.13, 31.87 theo.), 0.03 SiO_2 , 27.22 O (27.33 theo.); x-ray diffracton agreed with ASTM, no impurity line detected; heated to 990-1270 C for prolonged periods with grinding and mixing in between heatings.

DATA TABLE NO. 487 SPECIFIC HEAT OF NICKEL DIIRON TETRAOXIDE NiFe_2O_4 [Temperature, T, K; Specific Heat, C_p , Cal $\text{g}^{-1}\text{K}^{-1}$]

T	C_p
<u>CURVE 1</u>	
53.58	1.403×10^2
57.89	1.658
62.32	1.942
66.85	2.256
71.25	2.568
75.53	2.873
80.85	3.256
85.44	3.577
94.75	4.256
104.95	5.009
114.74	5.717
124.57	6.421
135.63	7.189
145.44	7.863
155.78	8.537
165.70	9.139
175.81	9.732
185.61	1.026×10^{-1}
195.67	1.080
206.03	1.132
215.96	1.179
225.85	1.222
236.38	1.268
245.78	1.306
256.20	1.345
266.39	1.381
276.26	1.414
286.48	1.449
295.93	1.479*
298.16	1.485

* Not shown on plot

SPECIFIC HEAT OF NICKEL IRON TETRAOXIDE (Nonstoichiometric) $Ni_x Fe_y O_4$

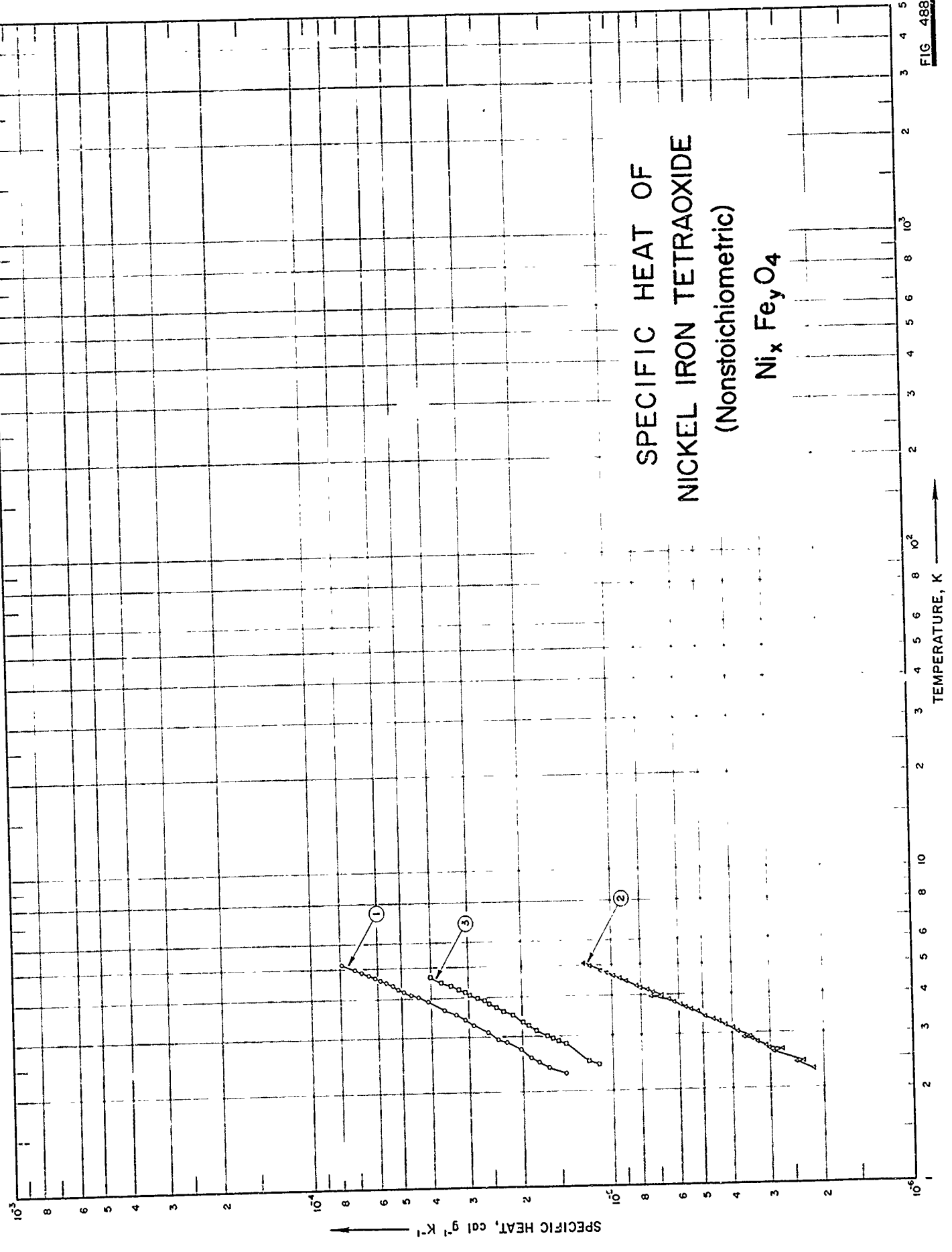

SPECIFICATION TABLE NO. 488 SPECIFIC HEAT OF NICKEL IRON TETRAOXIDE (nonstoichiometric) $\text{Ni}_x\text{Fe}_y\text{O}_4$

[For Data Reported in Figure and Table No. 488]

Curve No.	Ref. No.	Year	Temp. Range, K	Reported Error, %	Name and Specimen Designation	Composition (weight percent)	Specifications and Remarks
1	383	1961	2.3-5.2		$\text{Ni}_0.33\text{Fe}_{2.67}\text{O}_4$	50.14 Fe, 22.02 Ni; x-ray lattice parameter = 8.343 Å.	
2	383	1961	2.3-5.1		$\text{Ni}_0.34\text{Fe}_{2.66}\text{O}_4$	48.80 Fe, 23.53 Ni; x-ray lattice parameter = 8.339 Å.	
3	383	1961	2.4-4.7		$\text{Ni}_0.58\text{Fe}_{2.42}\text{O}_4$	60.14 Fe, 12.34 Ni; x-ray lattice parameter = 8.362 Å.	

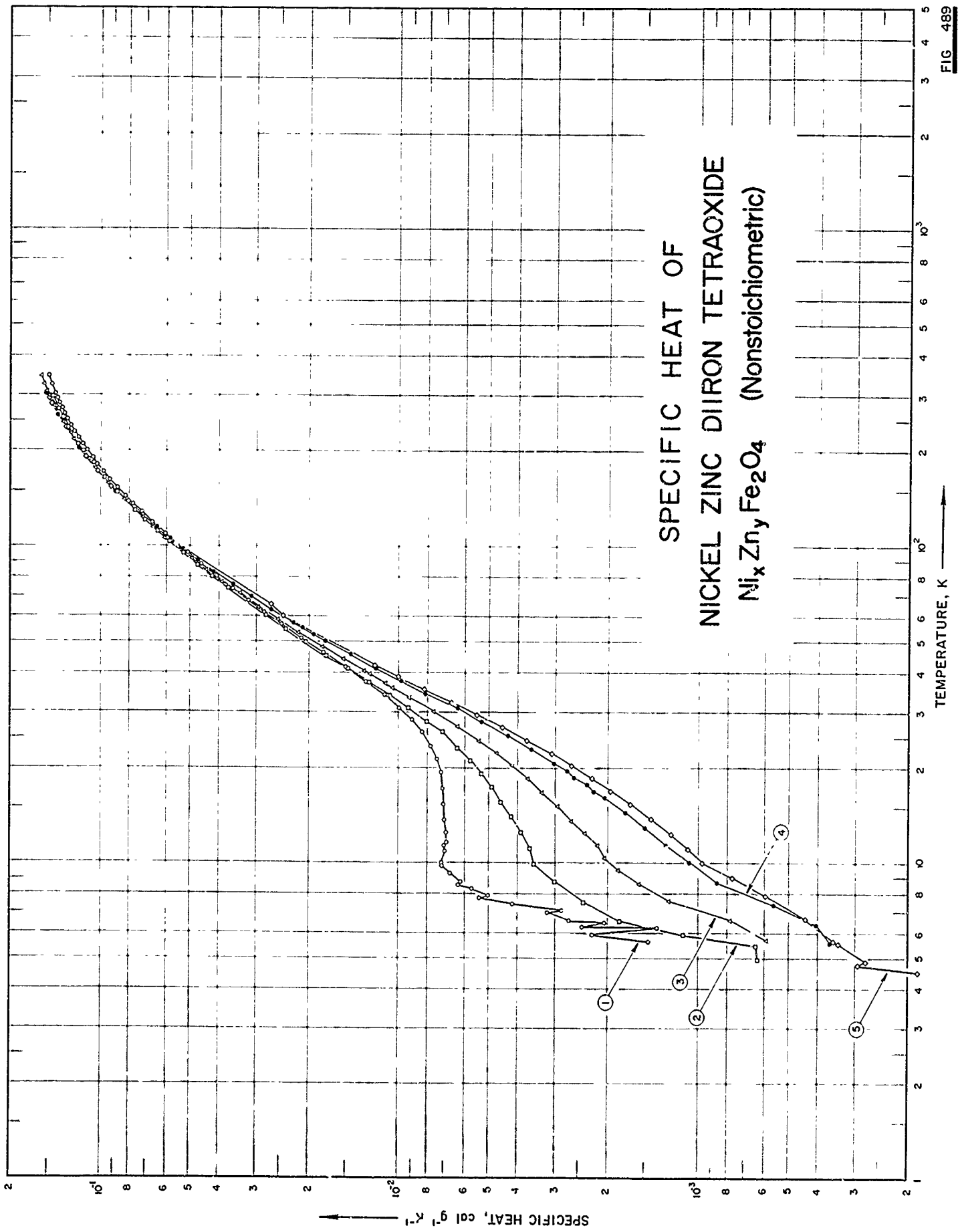

FIG 489

SPECIFICATION TABLE NO. 489 SPECIFIC HEAT OF NICKEL ZINC DIIRON TETRAOXIDE (nonstoichiometric) $Ni_xZn_yFe_2O_4$

[For Data Reported in Figure and Table No. 489]

Curve No.	Ref. No.	Year	Temp. Range, K	Reported Error, %	Name and Specimen Designation	Composition (weight percent), Specifications and Remarks
1	395	1957	6-345		$Ni_{0.1}Zn_{0.9}Fe_2O_4$	Very pure and carefully prepared; annealed at 1200 C.
2	395	1957	5-298		$Ni_{0.2}Zn_{0.8}Fe_2O_4$	Same as above.
3	395	1957	6-346		$Ni_{0.3}Zn_{0.7}Fe_2O_4$	Same as above.
4	395	1957	6-304		$Ni_{0.4}Zn_{0.6}Fe_2O_4$	Commercial grade material.
5	395	1957	5-300		$Ni_{0.4}Zn_{0.6}Fe_2O_4$	46.8 ± 0.1 Fe (46.84 theo.); very pure and carefully prepared; annealed at 900 C.

DATA TABLE NO. 489 (continued)

T	C _p CURVE 4 (cont.) Series 2 (cont.)	T	C _p CURVE 5 (cont.) Series 1 (cont.)
114.12	6.472 x 10 ⁻²	201.18	1.167 x 10 ^{-1*}
122.47	7.068*	210.40	1.209*
131.20	7.676*	219.59	1.247*
140.13	8.276*	228.67	1.284*
149.01	8.851	237.58	1.318
158.03	9.404*	246.56	1.350*
167.25	9.945*	255.62	1.380*
168.47	1.001 x 10 ^{-1*}	264.65	1.410*
177.45	1.051*	273.70	1.439*
186.57	1.098*	282.71	1.465
195.75	1.143*	291.70	1.490
204.81	1.186	300.83	1.514*
213.75	1.225*	Series 2	
222.67	1.262*	4.50	2.9 x 10 ⁻⁴
231.62	1.297*	4.87	2.8
240.59	1.331*	5.65	3.6
249.57	1.364*	4.75	2.9
258.62	1.393	5.58	3.4
267.81	1.422*	5.49	3.4*
276.99	1.451*	6.66	4.40
286.10	1.476*	7.87	5.96
295.17	1.502*	8.96	7.72
304.24	1.525	10.00	9.719
CURVE 5 Series 1		11.11	1.078 x 10 ⁻³
63.23	2.653 x 10 ^{-2*}	12.38	1.237
69.11	3.085*	13.77	1.432
75.83	3.589*	15.27	1.685
83.16	4.153*	16.86	1.952
91.49	4.7894*	18.52	2.262
90.54	4.7210*	20.28	2.632
98.30	5.2906*	22.17	3.088
106.78	5.9143	24.37	3.717
115.28	6.5389*	26.80	4.501
123.12	7.1027*	29.37	5.470
130.73	7.6295*	32.14	6.674
138.60	8.1609	35.29	8.205
147.06	8.712*	38.67	1.004 x 10 ⁻²
155.74	9.253	42.16	1.208
164.52	9.773*	46.10	1.455*
173.47	1.028 x 10 ⁻¹	50.74	1.763*
182.58	1.076*	55.57	2.039*
191.87	1.123	60.34	2.440
		65.57	2.674

* Not shown on plot

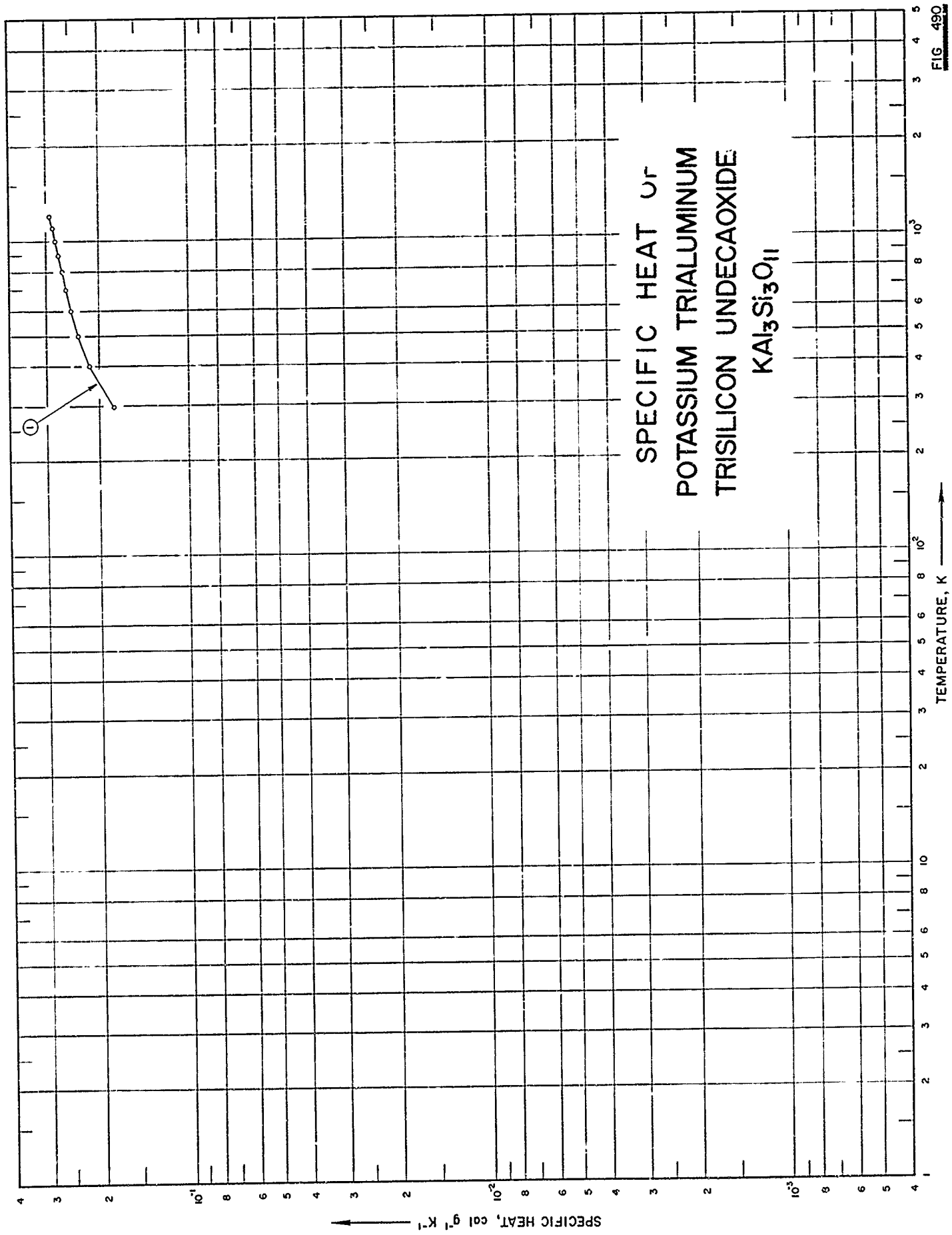

SPECIFICATION TABLE NO. 499 SPECIFIC HEAT OF POTASSIUM TRIALUMINUM TRISILICON UNDECAOXIDE $KAl_3Si_3O_{11}$

[For Data Reported in Figure and Table No. 490]

Curve No.	Ref. No.	Year	Temp. Range, K	Reported Error, %	Name and Specimen Designation	Composition (weight percent), Specifications and Remarks
1	397	1964	298-1200	0.1	Dehydrated Muscovite	47.97 SiO ₂ , 35.00 Al ₂ O ₃ , 11.22 K ₂ O, 3.37 Fe ₂ O ₃ , 1.04 Na ₂ O, 0.83 MgO, 0.49 FeO, 0.08 TiO ₂ ; prepared by heating muscovite for 35 hrs at 900-1000 K.

DATA TABLE NO. 490 SPECIFIC HEAT OF POTASSIUM TRIALUMINUM TRISILICON UNDECAOXIDE $KAl_3Si_3O_{11}$ [Temperature, T, K; Specific Heat, C_p , Cal g⁻¹K⁻¹]

T	C_p
<u>CURVE 1</u>	
298.15	1.783×10^{-1}
300	1.792*
400	2.153
500	2.348
600	2.478
700	2.576
800	2.659
900	2.732
1000	2.799
1100	2.861
1200	2.922

* Not shown on plot

FIG. 491

SPECIFIC HEAT OF
POTASSIUM TRIALUMINUM TRISILICON
UNDECAOXIDE MONOHYDRATE
 $KAl_3Si_3O_{11} \cdot H_2O$

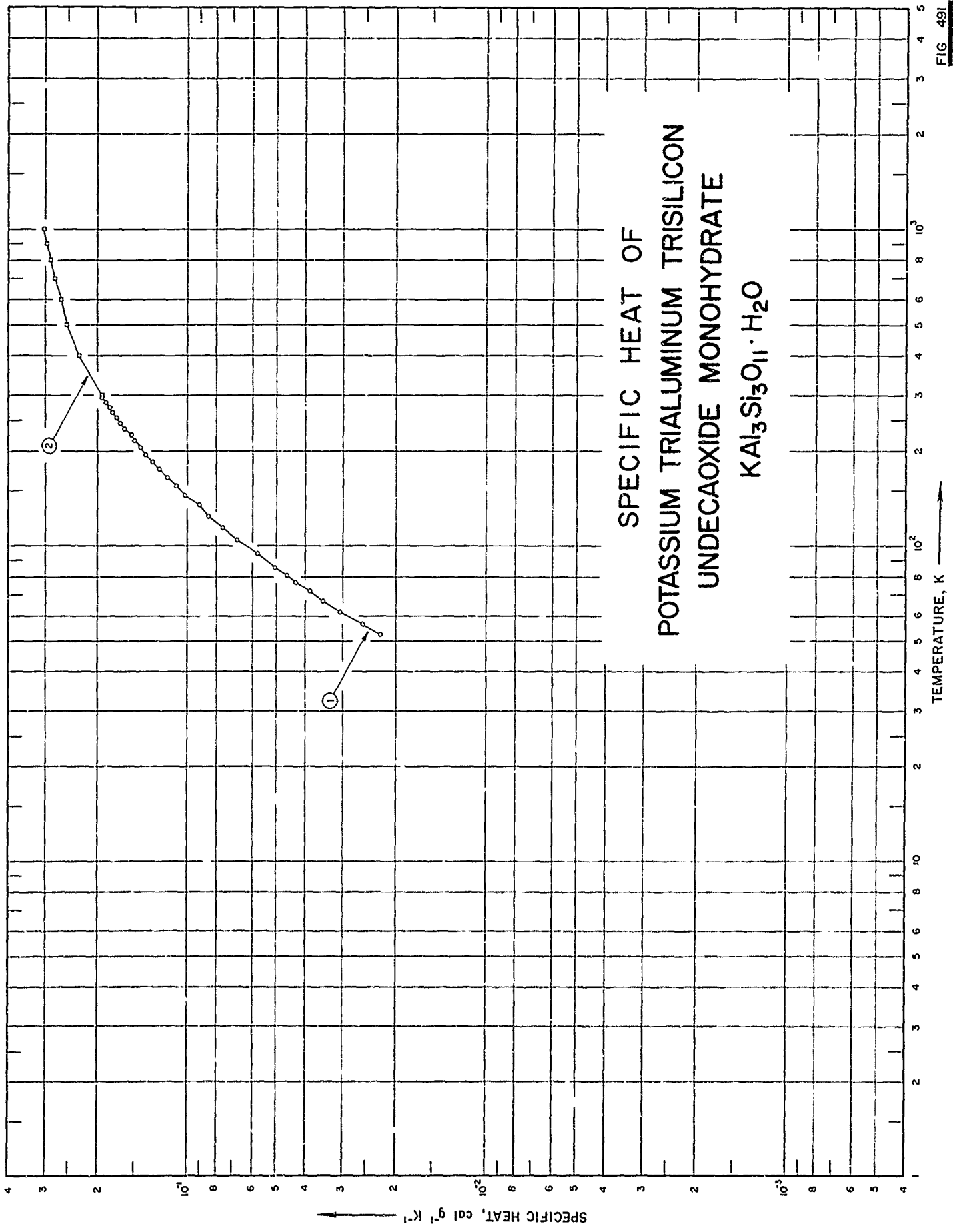

SPECIFICATION TABLE NO. 491 SPECIFIC HEAT OF POTASSIUM TRIALUMINUM TRISILICON UNDECAOXIDE MONOHYDRATE $KAl_3Si_3O_{11} \cdot H_2O$

[For Data Reported in Figure and Table No. 491]

Curve No.	Ref. No.	Year	Temp. Range, K	Reported Error, %	Name and Specimen Designation	Composition (weight percent), Specifications and Remarks
1	396	1963	53-297	0.3	Muscovite	45.79 SiO ₂ , 33.47 Al ₂ O ₃ , 10.73 K ₂ O, 4.47 H ₂ O, 3.22 Fe ₂ O ₃ , 0.99 Na ₂ O, 0.79 MgO, 0.47 FeO, 0.08 TiO ₂ , nil CaO; ground to -20 mesh; dried at 110 C.
2	397	1964	298-1000	0.2	Muscovite	45.75 SiO ₂ , 33.47 Al ₂ O ₃ , 10.73 K ₂ O, 4.46 H ₂ O, 3.22 Fe ₂ O ₃ , 0.99 Na ₂ O, 0.79 MgO, 0.47 FeO, 0.08 TiO ₂ ; natural sample of thin plates about 1 in. size; ground to -20 mesh; dried at 110 C.

DATA TABLE NO. 491 SPECIFIC HEAT OF POTASSIUM TRIALUMINUM TRISILICON UNDECAOXIDE MONOHYDRATE $KAl_3Si_3O_{11} \cdot H_2O$ [Temperature, T, K; Specific Heat, C_p , Cal $g^{-1} K^{-1}$]

T	C_p
<u>CURVE 1</u>	
52.59	2.252×10^{-2}
56.81	2.588
61.89	3.073
67.13	3.502
72.05	3.886
76.81	4.321
80.61	4.625
85.58	5.099
94.73	5.825
105.09	6.804
114.96	7.642
124.84	8.478
136.09	9.139
146.15	1.021×10^{-1}
156.09	1.095
166.20	1.171
176.27	1.245
186.18	1.312
196.30	1.381
206.40	1.439
216.90	1.505
226.74	1.539
236.42	1.622
246.10	1.674
256.75	1.727
266.98	1.780
276.64	1.820
287.02	1.876
296.61	1.928
<u>CURVE 2</u>	
298.15	1.928×10^{-1} *
300	1.938
400	2.315
500	2.525
600	2.669
700	2.783
800	2.879
900	2.967
1000	3.048

* Not shown on plot

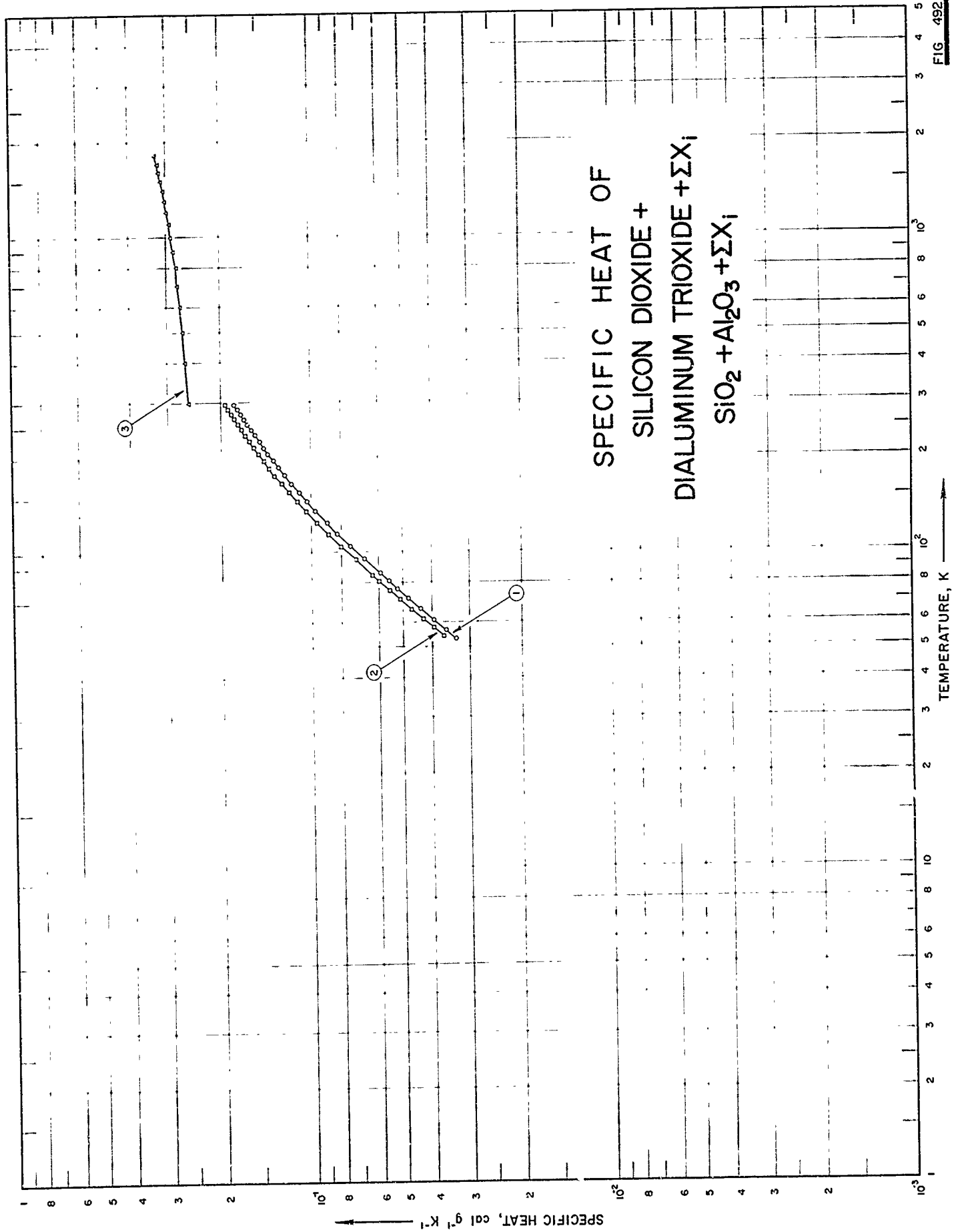

SPECIFICATION TABLE NO. 492 SPECIFIC HEAT OF SILICON DIOXIDE + DIALUMINUM TRIOXIDE + ΣX_1 $\text{SiO}_2 + \text{Al}_2\text{O}_3 + \Sigma X_1$

[For Data Reported in Figure and Table No. 492]

Curve No.	Ref. No.	Year	Temp. Range, K	Reported Error, %	Name and Specimen Designation	Composition (weight percent), Specifications and Remarks
1	357	1948	53-297		Perlite, dehydrated Sample B	Completely dehydrated by igniting at constant weight at 1000-1100 C.
2	357	1948	54.3-297		Perlite, hydrated Sample A	73.61 SiO_2 , 12.17 Al_2O_3 , 5.08 K_2O , 3.34 H_2O , 2.97 Na_2O , 1.51 Fe_2O_3 , 0.84 CaO ; sample from Superior, Arizona; crushed in diamond mortar and screened; dried at 120 C.
3	357	1948	298-1816		Perlite, dehydrated Sample B	Completely dehydrated by igniting at constant weight at 1000-1100 C; high temperature test.

DATA TABLE NO. 492 SPECIFIC HEAT OF SILICON DIOXIDE + DIALUMINUM TRIOXIDE · ΣX₁ SiO₂ + Al₂O₃ + ΣX₂Temperature, T, K; Specific Heat, C_p, Cal g⁻¹ K⁻¹

T	C _p	T	C _p
53.0	3.355 × 10 ⁻²	84.5	6.319 × 10 ⁻²
56.5	3.608	94.5	7.162
60.8	3.962	104.5	8.000
66.0	4.385	114.7	8.840
71.2	4.814	124.4	9.612
76.2	5.225	135.7	1.049 × 10 ⁻¹
80.8	5.578	146.1	1.123
85.6	5.958	156.1	1.196
95.3	6.718	166.0	1.262
104.9	7.470	175.9	1.329
114.8	8.263	186.1	1.387
124.4	8.929	196.3	1.446
136.1	9.773	206.1	1.503
146.3	1.046 × 10 ⁻¹	216.6	1.561
155.8	1.109	226.8	1.613
166.2	1.175	235.9	1.662
176.3	1.236	246.1	1.709
186.2	1.291	256.2	1.759
196.3	1.347	266.1	1.803
206.5	1.401	276.5	1.845
216.5	1.452	286.6	1.8918
225.6	1.494	296.2	1.9334
227.5	1.503*		
236.4	1.546		
236.4	1.547*		
246.2	1.588		
246.2	1.594*		
256.4	1.645		
256.5	1.642*		
266.4	1.685		
266.8	1.686*		
276.6	1.726		
276.9	1.730*		
286.7	1.771		
286.7	1.771*		
296.8	1.813		
CURVE 3			
298.15			2.56 × 10 ⁻¹
300			2.57*
400			2.61
500			2.66
600			2.71
700			2.75
800			2.80
900			2.84
1000			2.89
1100			2.94
1200			2.98
1300			3.03
1400			3.08
1500			3.12
1600			3.17
1700			3.22
1810			3.27*
1816			3.27
CURVE 2			
54.3	3.655 × 10 ⁻²		
57.5	3.933		
61.3	4.275		
65.9	4.680		
70.6	5.100		
75.4	5.534		
80.7	5.991		

* Not shown on plot

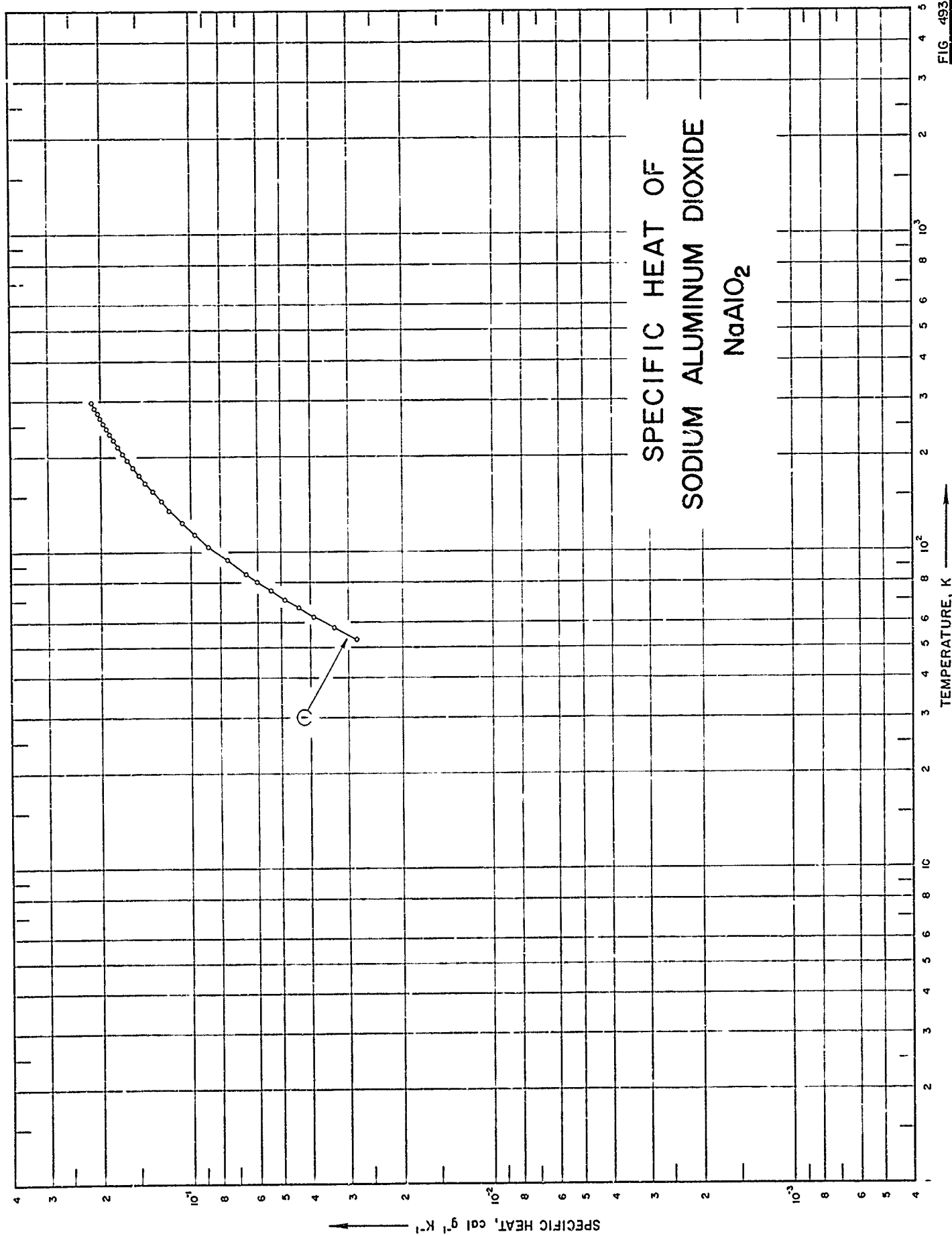

SPECIFICATION TABLE NO. 493 SPECIFIC HEAT OF SODIUM ALUMINUM DIOXIDE NaAlO_2

[For Data Reported in Figure and Table No. 493]

Curve No.	Ref. No.	Year	Temp. Range, K	Reported Error, %	Name and Specimen Designation	Composition (weight percent), Specifications and Remarks
1	390	1955	53-298			62.08 Al_2O_3 (62.19 theo.); prepared from reagent-grade Na_2CO_3 and pure hydrated Al_2O_3 ; heated six times for total 89 hrs at 1000-1050 C.

DATA TABLE NO. 493 SPECIFIC HEAT OF SODIUM ALUMINUM DIOXIDE NaAlO_2 [Temperature, T, K; Specific Heat, C_p , Cal $\text{g}^{-1}\text{K}^{-1}$]

T	C_p
CURVE 1	
53.10	2.829×10^{-2}
57.90	3.359
62.61	3.909
66.71	4.386
70.91	4.879
75.58	5.434
80.57	6.029
85.14	6.565
94.57	7.635
104.83	8.754
114.46	9.743
124.64	1.074×10^{-1}
136.21	1.181
145.78	1.264
155.84	1.347
165.90	1.424
175.94	1.499
185.79	1.565
195.94	1.630
206.09	1.693
216.38	1.757
226.04	1.813
236.05	1.863
245.70	1.913
256.15	1.965
266.66	2.009
276.23	2.047
286.50	2.096
296.10	2.130*
298.16	2.137

* Not shown on plot

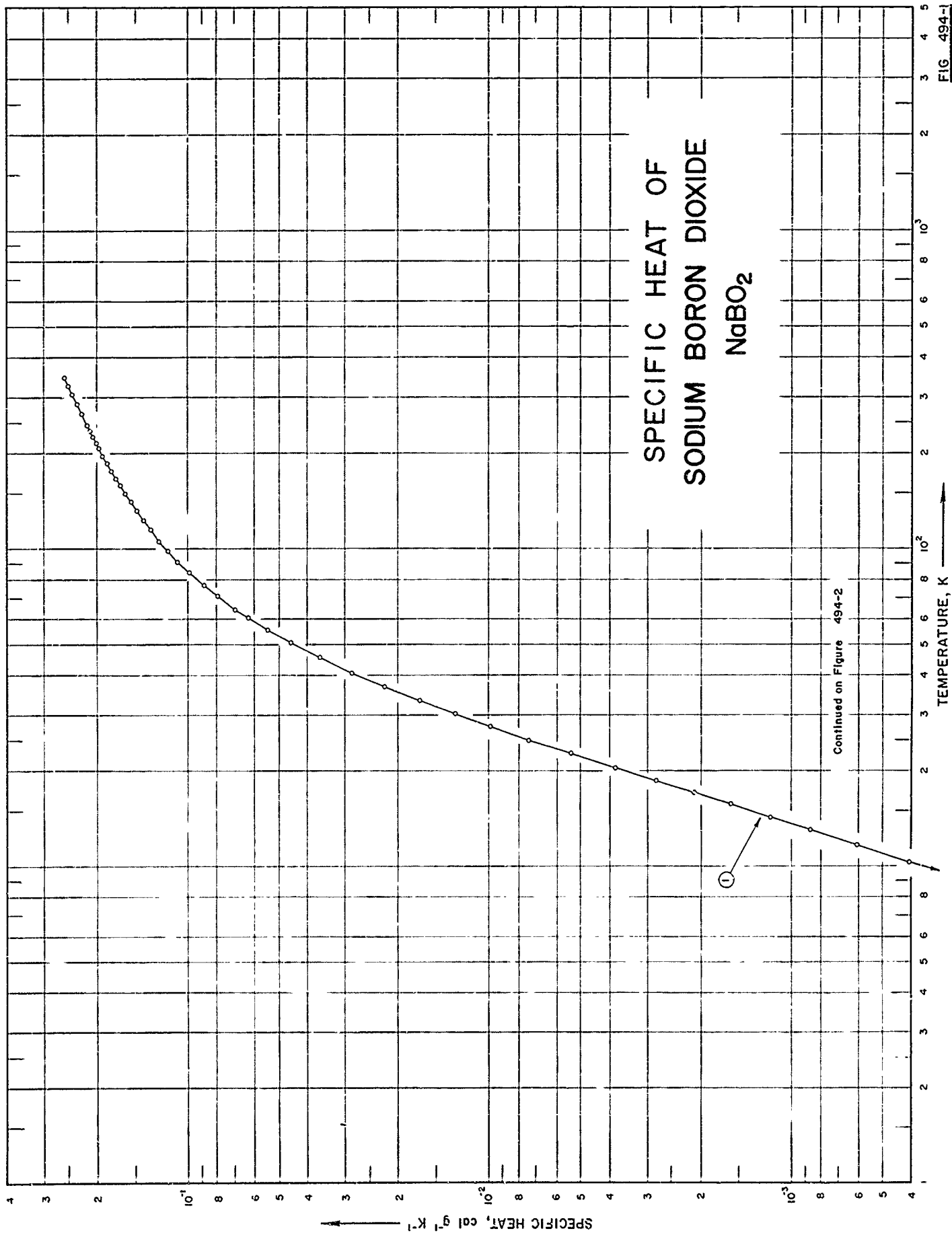
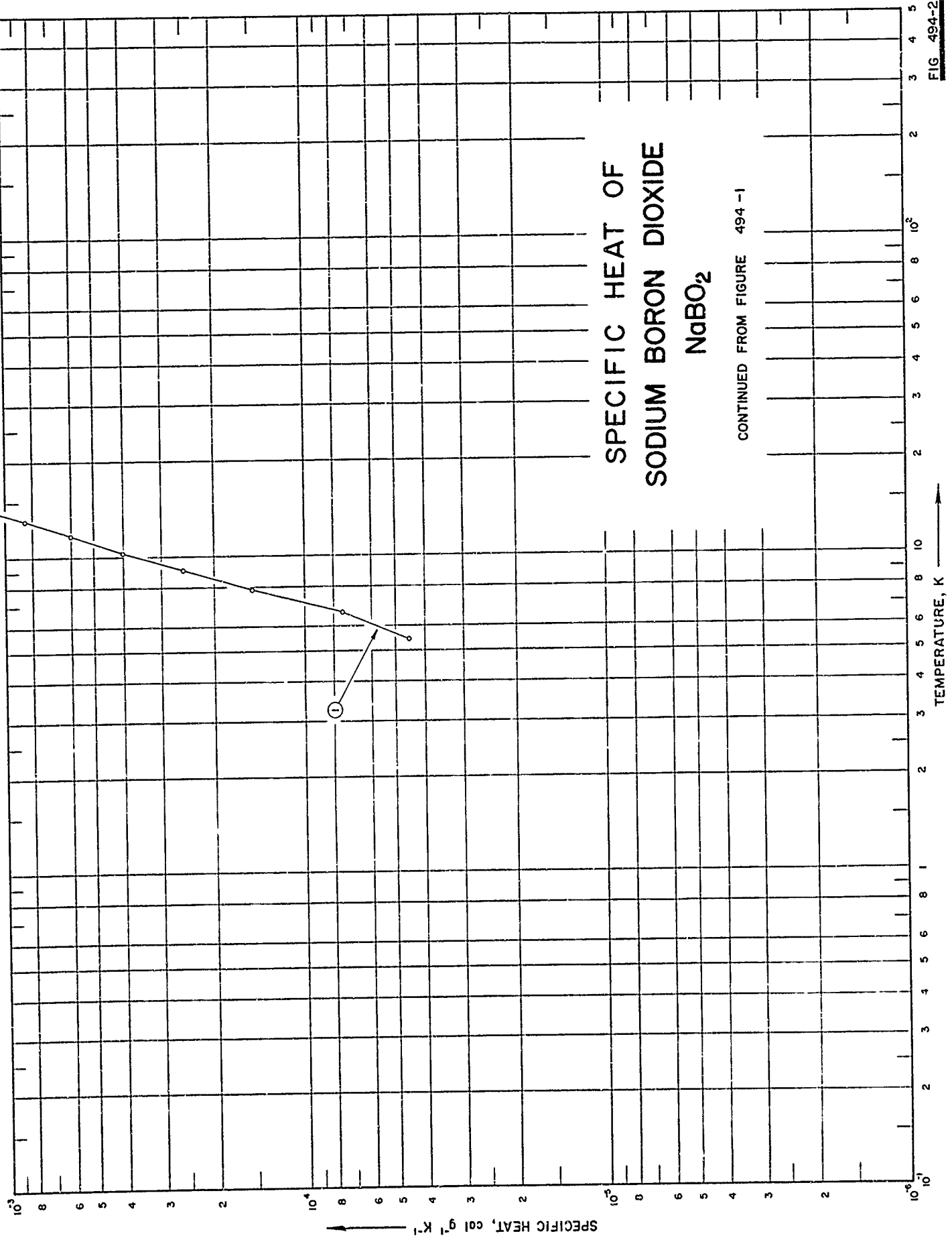

FIG 494-1

SPECIFIC HEAT OF SODIUM BORON DIOXIDE NaBO2

CONTINUED FROM FIGURE 494-1



SPECIFICATION TABLE NO. 494 SPECIFIC HEAT OF SODIUM BORON DIOXIDE NaBO_2

[For Data Reported in Figure and Table No. 494]

Curve No.	Ref. No.	Year	Temp. Range, K	Reported Error, %	Name and Specimen Designation	Composition (weight percent), Specifications and Remarks
1	399	1960	5-350	0.10		52.91 B_2O_3 , 47.11 Na_2O ; recrystallized evacuated at 25 C for 3 days.

DATA TABLE NO. 494 SPECIFIC HEAT OF SODIUM BORON DIOXIDE NaBO_2 [Temperature, T, K; Specific Heat, C_p , Cal $\text{g}^{-1}\text{K}^{-1}$]

T	C_p	T	C_p
CURVE 1		CURVE 1 (cont.)	
5.48	4.558×10^{-6}	245.47	2.168×10^{-1}
6.68	7.597	255.80	2.215*
7.83	1.520×10^{-4}	265.98	2.261
9.08	2.583	276.10	2.304*
10.38	4.103	286.16	2.348
11.72	6.078	296.22	2.387*
13.06	8.661	306.34	2.430
14.40	1.185×10^{-3}	316.45	2.468*
15.74	1.595	326.55	2.504
17.14	2.112	336.56	2.542*
18.69	2.811	345.49	2.577
20.53	3.844		
22.74	5.379		
25.15	7.400		
27.64	9.907		
30.36	1.305×10^{-2}		
33.41	1.709		
36.80	2.225		
40.89	2.861		
45.57	3.654		
50.72	4.553		
55.96	5.467		
60.88	6.309		
64.98	6.996		
71.20	7.968		
77.94	8.977*		
84.46	9.900		
91.34	1.079×10^{-1}		
99.00	1.166		
107.24	1.255		
115.59	1.337		
123.94	1.415		
132.48	1.489		
140.98	1.558		
149.44	1.620		
158.07	1.681		
167.33	1.744		
177.16	1.805		
187.21	1.866		
197.36	1.924		
207.75	1.978		
215.06	2.018		
225.14	2.070		
235.23	2.118		

* Not shown on plot

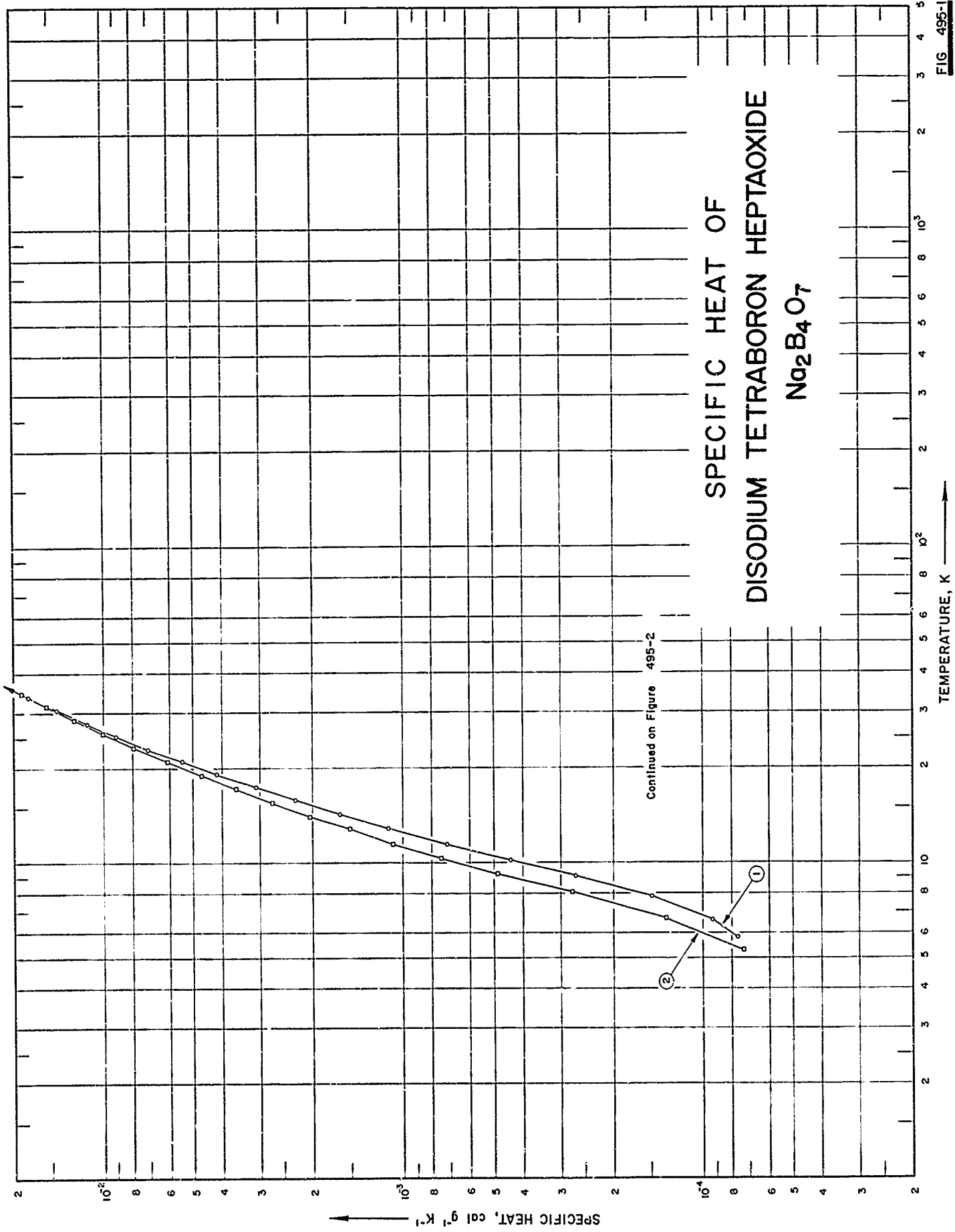
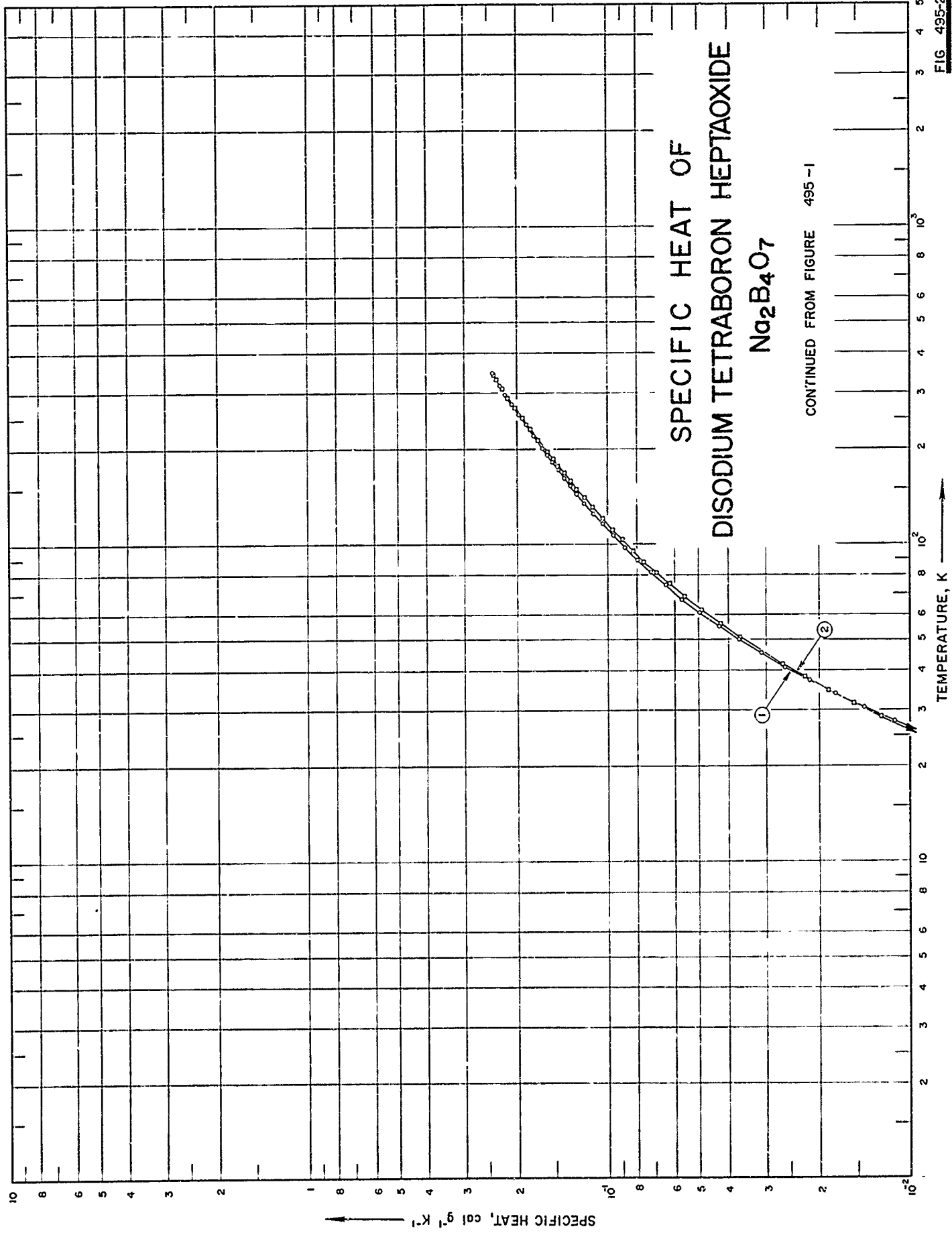

FIG 495-1



SPECIFICATION TABLE NO. 495 SPECIFIC HEAT OF DISODIUM TETRABORON HEPTAOXIDE $\text{Na}_2\text{B}_4\text{O}_7$

[For Data Reported in Figure and Table No. 495]

Curve No.	Ref. No.	Year	Temp. Range, K	Reported Error, %	Name and Specimen Designation	Composition (weight percent), Specifications and Remarks
1	399	1960	5-350	≤5	Crystalline	99.87 ± 0.04 $\text{Na}_2\text{B}_4\text{O}_7$; prepared by crystallizing dehydrated sample of analytic reagent-grade sodium tetraborate decahydrate from molten state under carefully controlled conditions; helium atmosphere.
2	399	1960	5-343	≤5	Vitreous	100.00 ± 0.04 $\text{Na}_2\text{B}_4\text{O}_7$; reagent-grade sodium tetraborate decahydrate was heated to 820 for 30 min; annealed for 15 min at 420 C; cooled in anhydrous atmosphere; helium atmosphere.

DATA TABLE NO. 495 SPECIFIC HEAT OF DISODIUM TETRABORON HEPTAOXIDE $\text{Na}_2\text{B}_4\text{O}_7$
 [Temperature, T, K; Specific Heat, Cp, Cal g⁻¹K⁻¹]

T	C _p	T	C _p	T	C _p
CURVE 1 Series I		CURVE 1 (cont.) Series I (cont.)		CURVE 2 (cont.)	
5.82	7.652×10^{-6}	257.40	2.003×10^{-1}	41.92	2.663×10^2
6.60	9.341	266.90	2.0651*	46.13	3.143*
7.81	1.481×10^{-4}	276.50	2.110	51.00	3.699
9.07	2.673	286.39	2.153*	56.38	4.319
10.21	4.422	296.65	2.251	62.26	4.969
11.50	7.155	306.88	2.260*	68.55	5.654
12.92	1.123×10^{-3}	317.02	2.310	75.01	6.320
14.37	1.630	327.09	2.360*	81.43	6.996
15.92	2.286	337.30	2.40*	88.06	7.716
17.52	3.095	347.69	2.45	95.20	8.313
19.21	4.189			103.03	9.013
21.03	5.451		Series II*	111.83	9.773
23.02	7.105			121.62	1.059×10^{-1}
25.23	9.063			131.54	1.140
27.73	1.138×10^{-2}	253.26	1.977×10^{-1}	140.88	1.213
30.61	1.432	262.55	2.027	149.95	1.282
33.80	1.784	271.91	2.081	159.04	1.348
37.25	2.176	281.41	2.132	168.25	1.415
41.09	2.631	291.36	2.182	177.49	1.480
45.45	3.153	301.61	2.236	186.79	1.542
50.18	3.729	311.91	2.287	196.08	1.605
55.32	4.346	322.22	2.335	205.13	1.664*
61.01	5.023	333.05	2.386	214.14	1.722
67.36	5.759	343.97	2.438	223.13	1.779*
74.48	6.534			232.21	1.834
81.61	7.304		CURVE 2	241.51	1.891*
89.18	8.084	5.31	7.504×10^{-5}	250.99	1.947
97.84	8.889	6.68	1.337×10^{-4}	260.78	2.005*
107.24	9.738	8.09	2.758	270.61	2.058
117.03	1.057×10^{-1}	9.22	4.894	280.35	2.112*
126.62	1.138	10.32	7.453	290.09	2.164
135.89	1.211	11.54	1.078×10^{-3}	300.00	2.216*
144.71	1.278	12.82	1.515	310.30	2.270
153.70	1.345	14.13	2.042	320.34	2.324*
162.66	1.410	15.59	2.728	331.13	2.370
172.08	1.476	17.21	3.597	343.63	2.431
181.88	1.541	19.01	4.705		
191.80	1.606	21.08	6.111		
201.60	1.669	23.41	7.940		
211.13	1.730^*	25.95	1.009×10^{-2}		
220.53	1.789	28.71	1.263		
229.84	1.844*	31.69	1.559		
238.94	1.897	34.85	1.884		
248.07	1.949*	38.23	2.256		

* Not shown on plot

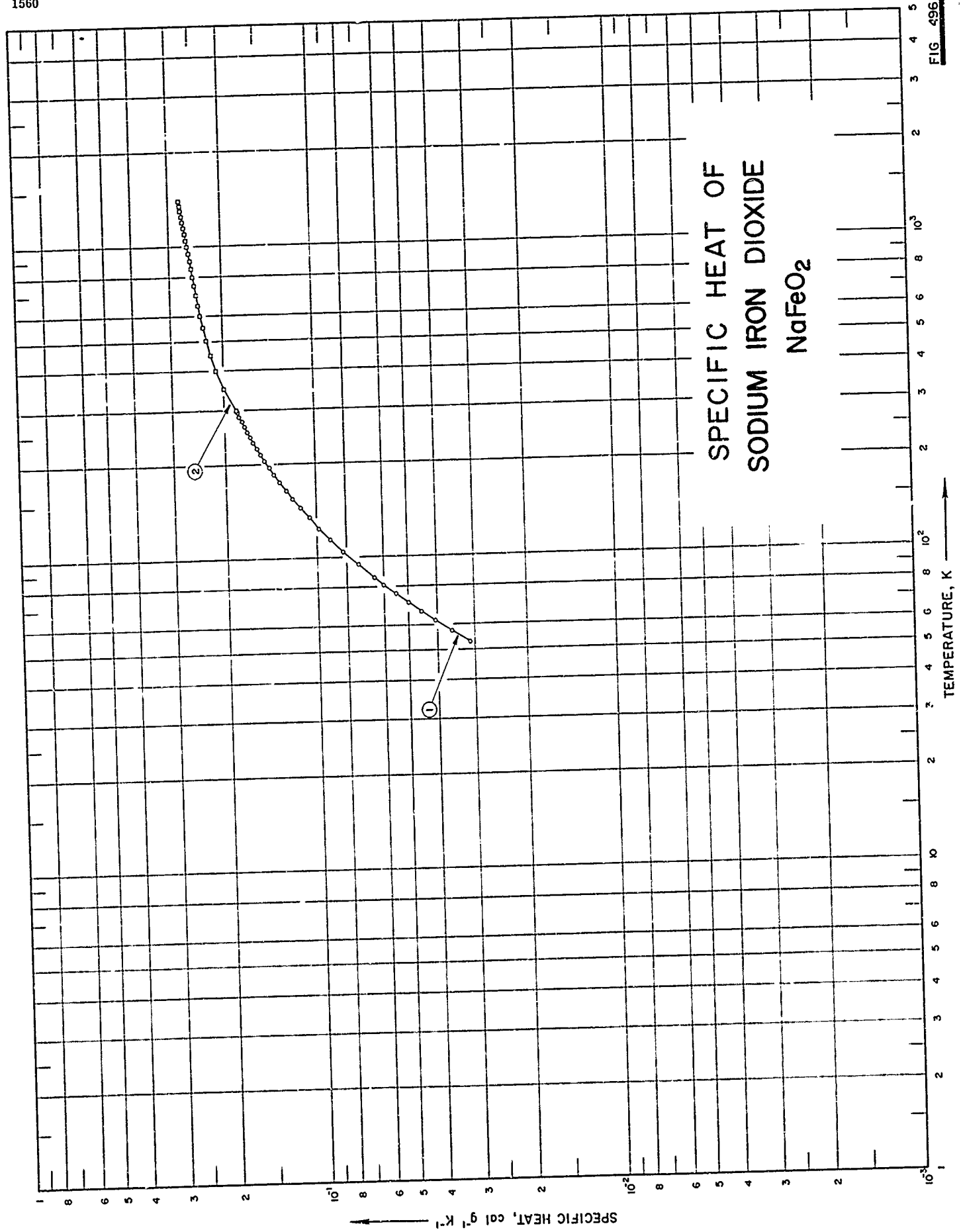

SPECIFICATION TABLE NO. 496 SPECIFIC HEAT OF SODIUM IRON DIOXIDE NaFeO_2

[For Data Reported in Figure and Table No. 496]

Curve No.	Ref. No.	Year	Temp. Range, K	Reported Error, %	Name and Specimen Designation	Composition (weight percent), Specifications and Remarks
1	400	1958	298-1400	0.3		98.6 NaFeO_2 ; argon atmosphere.
2	390	1955	53-296			72.05 Fe_2O_3 (72.04 theo.), 0.06 SiO_2 ; prepared from reagent-grade Na_2CO_3 and pure ferric oxide; heated 12 times for total 60 hrs at 1000-1050 C and 10 hrs at 1100-1150 C.

DATA TABLE NO. 496 SPECIFIC HEAT OF SODIUM IRON DIOXIDE NaFeO₂[Temperature, T, K; Specific Heat, C_p, Cal g⁻¹K⁻¹]

T	C _p	
	CURVE 1	CURVE 2 (cont.)
298.15	1.823 x 10 ⁻¹	1.454 x 10 ⁻¹
300	1.831	1.481
350	2.007	1.529
400	2.127	1.573
450	2.215	1.61
500	2.277	1.652
550	2.336	1.691
600	2.381	1.724
650	2.420	1.753
700	2.454	1.791
750	2.485	1.817
800	2.513	
850	2.539	
900	2.563	
950	2.587	
1000	2.609	
1050	2.631	
1100	2.652	
1150	2.672	
1200	2.691	
1250	2.711	
1300	2.729	
1350	2.748	
1400	2.767	

T	C _p	
	CURVE 2	CURVE 2 (cont.)
53.16	3.119 x 10 ⁻²	
57.70	3.572	
62.23	4.054	
66.82	4.529	
71.34	4.995	
75.95	5.475	
81.17	6.019	
85.68	6.465	
94.69	7.320	
104.84	8.242	
114.65	9.049	
124.32	9.870	
135.73	1.068 x 10 ⁻¹	
145.63	1.139	
155.71	1.206	
166.10	1.269	
176.17	1.326	
186.17	1.383	

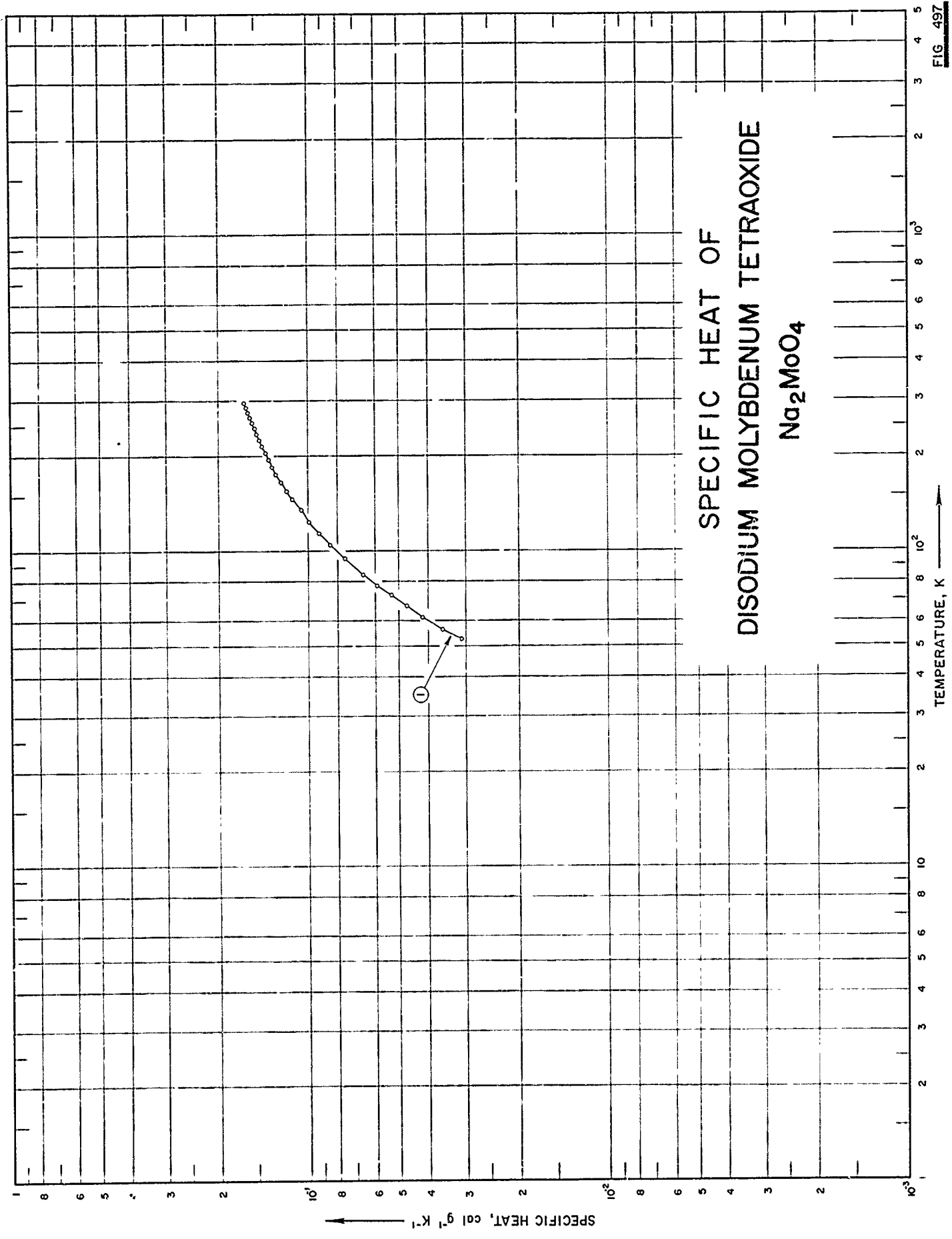

SPECIFIC HEAT, cal g⁻¹ K⁻¹

TEMPERATURE, K

SPECIFICATION TABLE NO. 497 SPECIFIC HEAT OF DISODIUM MOLYBDENUM TETRAOXIDE Na_2MoO_4

[For Data Reported in Figure and Table No. 497]

Curve No.	Ref. No.	Year	Temp. Range, K	Reported Error, %	Name and Specimen Designation	Composition (weight percent), Specifications and Remarks
1	368	1963	53-300	<0.3		69.89 MoO_3 .

DATA TABLE NO. 497 SPECIFIC HEAT OF DISODIUM MOLYBDENUM TETRAOXIDE Na_2MoO_4 [Temperature, T, K; Specific Heat, C_p , Cal g⁻¹K⁻¹]

T	C_p
CURVE 1	
52.67	3.123×10^{-2}
56.82	3.588
61.98	4.190
67.04	4.746
72.54	5.337
77.91	5.924
79.86	6.231*
84.17	6.570
94.84	7.566
105.03	8.494
114.27	9.232
124.36	9.975
136.55	1.059×10^{-1}
145.78	1.135
155.80	1.187
166.29	1.238
176.18	1.282
186.13	1.322
196.27	1.360
206.13	1.396
216.39	1.431
226.11	1.462
236.36	1.491
245.83	1.519
256.52	1.548
266.43	1.572
276.69	1.595
286.76	1.618
296.35	1.642

* Not shown on plot

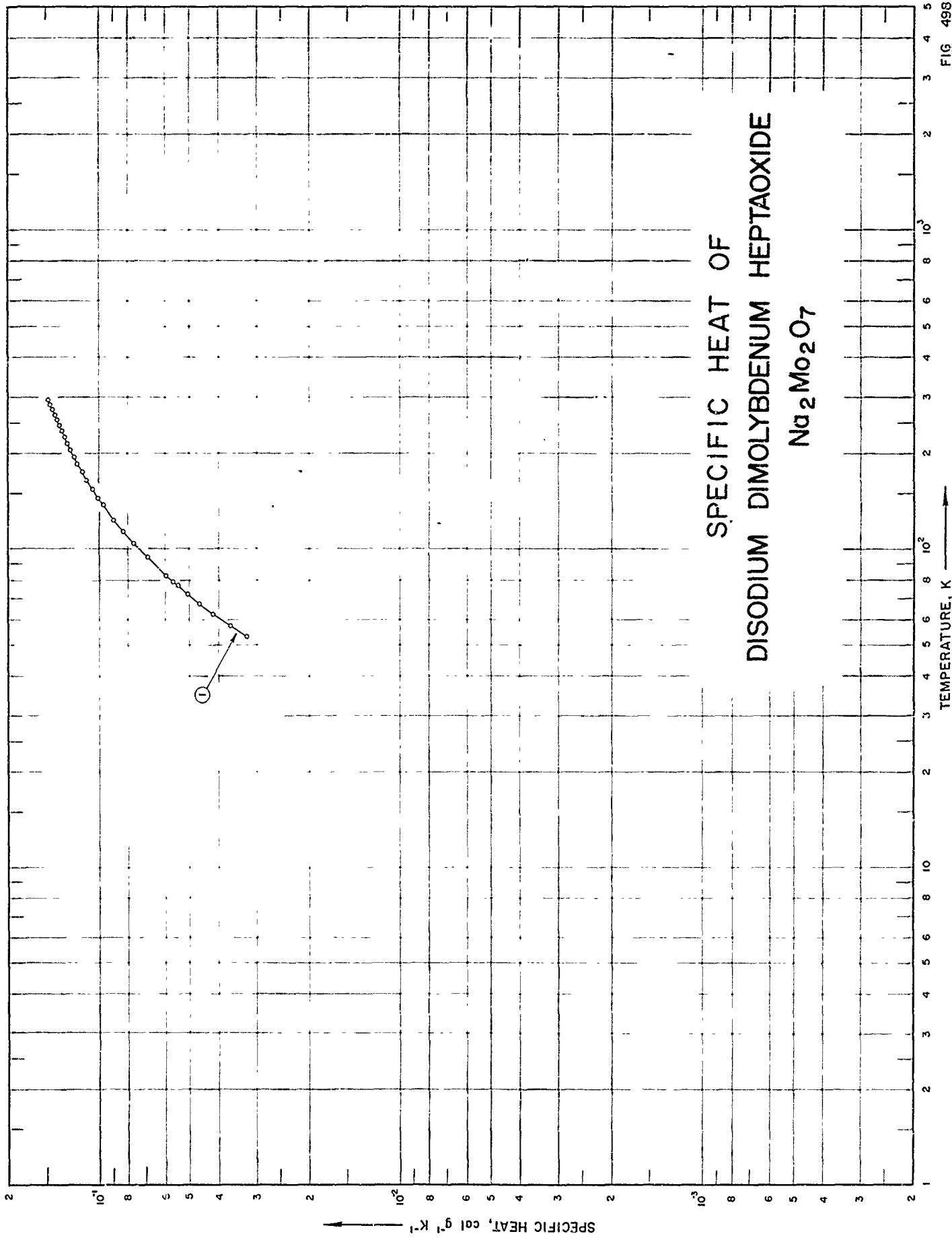

FIG. 498

SPECIFICATION TABLE NO. 498 SPECIFIC HEAT OF DISODIUM DIMOLYBDENUM HEPTAOXIDE $\text{Na}_2\text{Mo}_2\text{O}_7$

[For Data Reported in Figure and Table No. 498]

Curve No.	Ref. No.	Year	Temp. Range, K	Reported Error, %	Name and Specimen Designation	Composition (weight percent), Specifications and Remarks
1	401	1963	53-296	0.3		82.29 MoO ₃ .

DATA TABLE NO. 498 SPECIFIC HEAT OF DISODIUM DIMOLYBDENUM HEPTAOXIDE $\text{Na}_2\text{Mo}_2\text{O}_7$
 [Temperature, T, K; Specific Heat, C_p , Cal $\text{g}^{-1}\text{K}^{-1}$]

T	C_p
<u>CURVE 1</u>	
53.24	3.250×10^{-2}
57.58	3.684
62.62	4.196
67.65	4.662
72.43	5.099
77.01	5.516
79.41	5.717
82.93	6.025
94.71	6.966
105.02	7.717
114.52	8.366
124.49	8.989
137.84	9.744
145.80	1.015×10^{-1}
155.78	1.061
166.00	1.106
176.00	1.143
186.64	1.186
196.30	1.219
206.29	1.252
216.17	1.282
226.25	1.310
235.99	1.339
245.97	1.365
256.35	1.385
266.58	1.414
276.47	1.438
286.75	1.459
296.41	1.480

SPECIFIC HEAT OF DISODIUM SILICON TRIOXIDE Na2SiO3

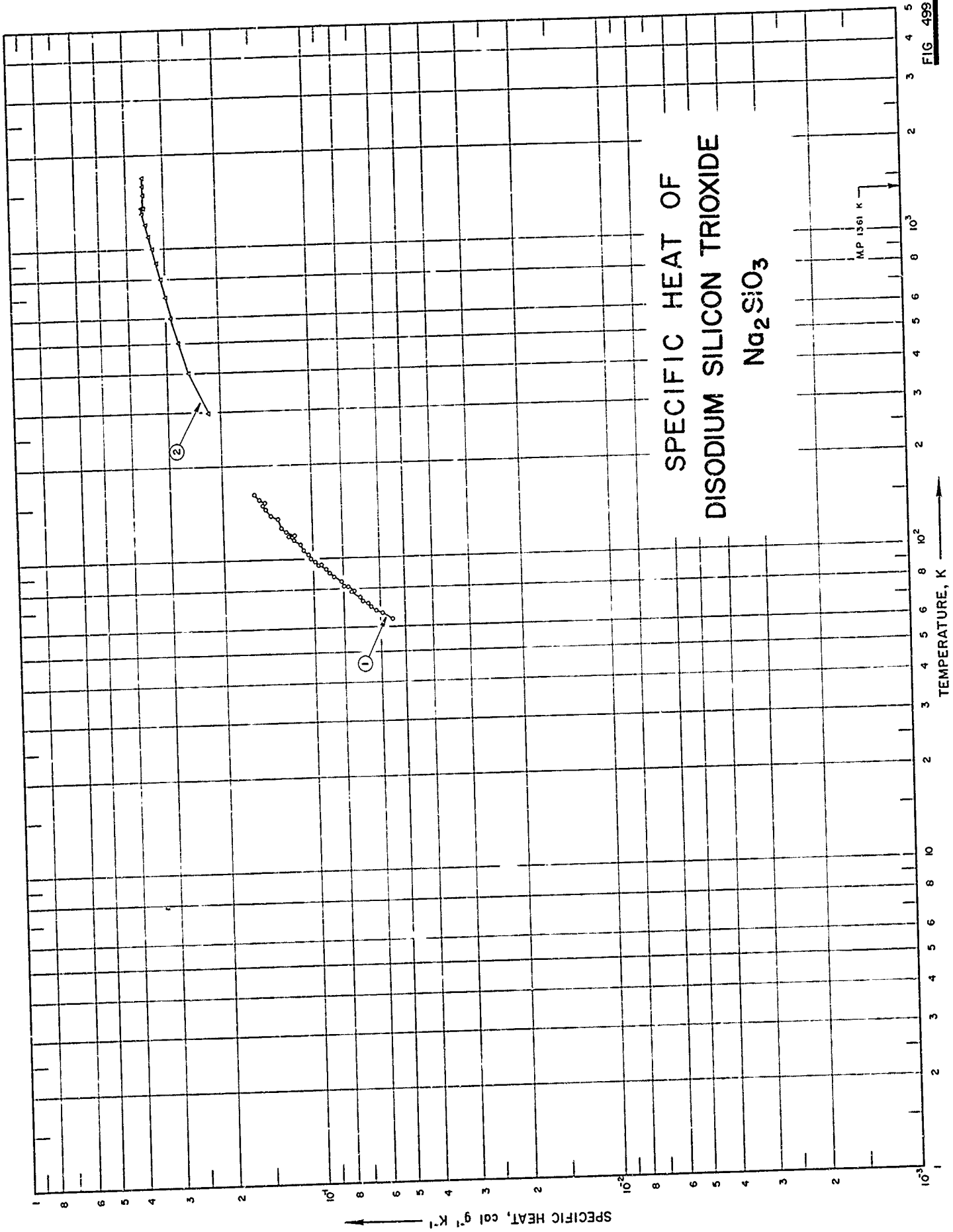

SPECIFICATION TABLE NO. 499 SPECIFIC HEAT OF DISODIUM SILICON TRIOXIDE Na_2SiO_3

[For Data Reported in Figure and Table No. 499]

Curve No.	Ref. No.	Year	Temp. Range, K	Reported Error, %	Name and Specimen Designation	Composition (weight percent), Specifications and Remarks
1	402	1953	64-162			
2	403	1945	298-1800	0.1-1		99.5 Na_2SiO_3

DATA TABLE NO. 499 SPECIFIC HEAT OF DISODIUM SILICON TRIOXIDE Na_2SiO_3 [Temperature, T, K; Specific Heat, C_p , Cal $g^{-1}K^{-1}$]

T	C_p		T	C_p
	CURVE 1	CURVE 2		
63.740	5.484×10^2		298.15	2.189×10^{-1}
66.752	5.936		300	2.198*
67.682	6.228		400	2.535
69.886	6.474		500	2.733
71.645	6.650		600	2.876
72.751	6.902		700	2.994
74.876	7.019		800	3.098
75.480	7.258		900	3.194
78.086	7.506		1000	3.285
78.226	7.393		1100	3.373
81.052	7.715		1200	3.458
81.194	7.987		1300	2.542
84.425	8.101		(s) 1361	3.593
84.524	8.141		(l) 1361	3.507*
87.328	8.595		1400	3.507*
89.854	8.857		1500	3.507
92.546	9.103		1600	3.507
95.550	9.414		1700	3.507
95.344	9.635			
97.924	9.889			
97.976	9.881*			
100.71	1.022×10^1			
101.16	1.016*			
103.60	1.029*			
104.27	1.045			
106.45	1.063*			
107.33	1.079			
109.23	1.090*			
110.33	1.113*			
112.08	1.108			
113.29	1.149*			
115.59	1.162			
118.99	1.209			
119.41	1.163			
122.95	1.230			
126.44	1.275			
129.83	1.296*			
135.58	1.314			
138.86	1.385			
145.30	1.434			
149.10	1.469			
152.47	1.447			
155.87	1.520			
159.23	1.538*			
162.48	1.571			

* Not shown on plot

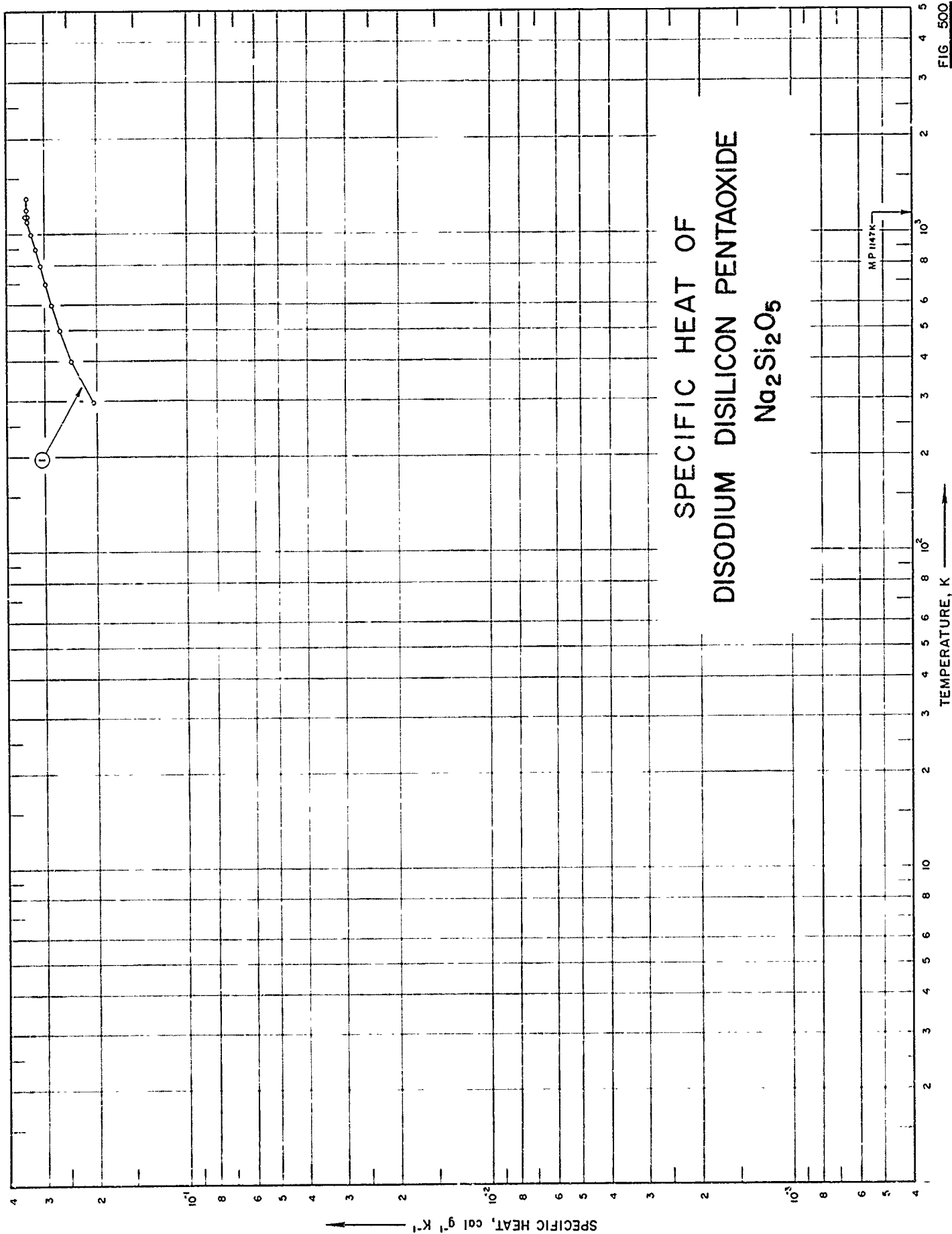

FIG 500

SPECIFICATION TABLE NO. 500 SPECIFIC HEAT OF DISODIUM DISILICON PENTAOXIDE $\text{Na}_2\text{Si}_2\text{O}_5$

[For Data Reported in Figure and Table No. 500]

Curve No.	Ref. No.	Year	Temp. Range, K	Reported Error, %	Name and Specimen Designation	Composition (weight percent), Specifications and Remarks
1	403	1945	298-1300	1		99.0 $\text{Na}_2\text{Si}_2\text{O}_5$.

DATA TABLE NO. 500 SPECIFIC HEAT OF DISODIUM DISILICON PENTAOXIDE $\text{Na}_2\text{Si}_2\text{O}_5$ [Temperature, T, K; Specific Heat, Cp, Cal g⁻¹K⁻¹]

T	C _p
298.15	2.054×10^{-1}
300	2.064*
400	2.441
500	2.665
600	2.830
700	2.965
800	3.086
900	3.198
1000	3.304
1100	3.407
(S)1147	3.454
(L)1147	3.422
1200	3.422
1300	3.422

* Not shown on plot

FIG. 501

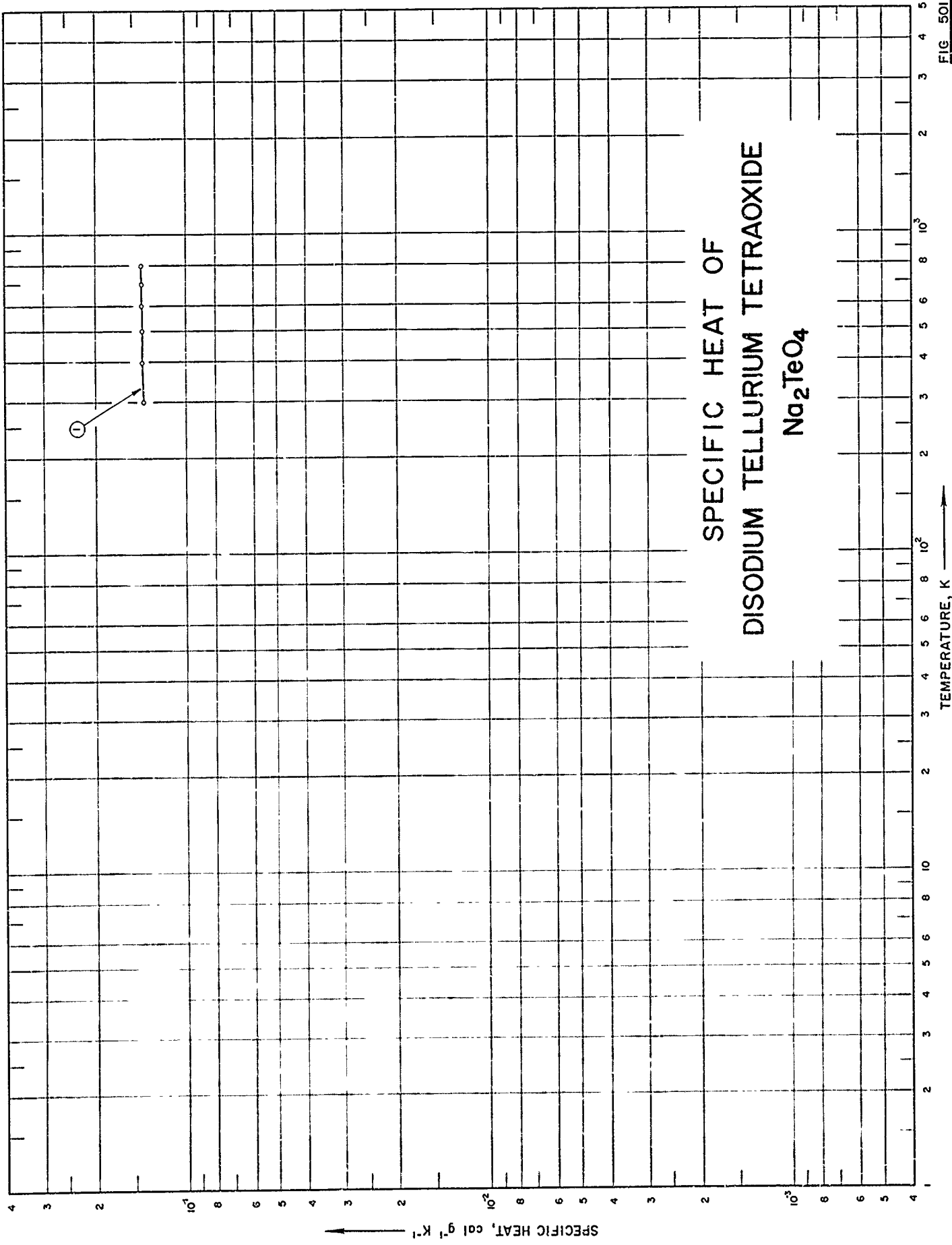

SPECIFICATION TABLE NO. 501 SPECIFIC HEAT OF DISODIUM TELLURIUM TETRAOXIDE Na_2TeO_4

[For Data Reported in Figure and Table No. 501]

Curve No.	Ref. No.	Year	Temp. Range, K	Reported Error, %	Name and Specimen Designation	Composition (weight percent), Specifications and Remarks
1	128	1962	300-800	0.5		> 99.99 Na_2TeO_4 , < 0.1 Ca, traces of Ag and Al; sample supplied by E. H. Sargent and Co. Inc.; sealed in argon atmosphere.

DATA TABLE NO. 501 SPECIFIC HEAT OF DISODIUM TELLURIUM TETRAOXIDE Na_2TeO_4
[Temperature, T, K; Specific Heat, C_p , Cal $\text{g}^{-1}\text{K}^{-1}$]

T	C_p
	<u>CURVE 1</u>
300	1.397×10^{-1}
400	1.398
500	1.406
600	1.402
700	1.403
800	1.405

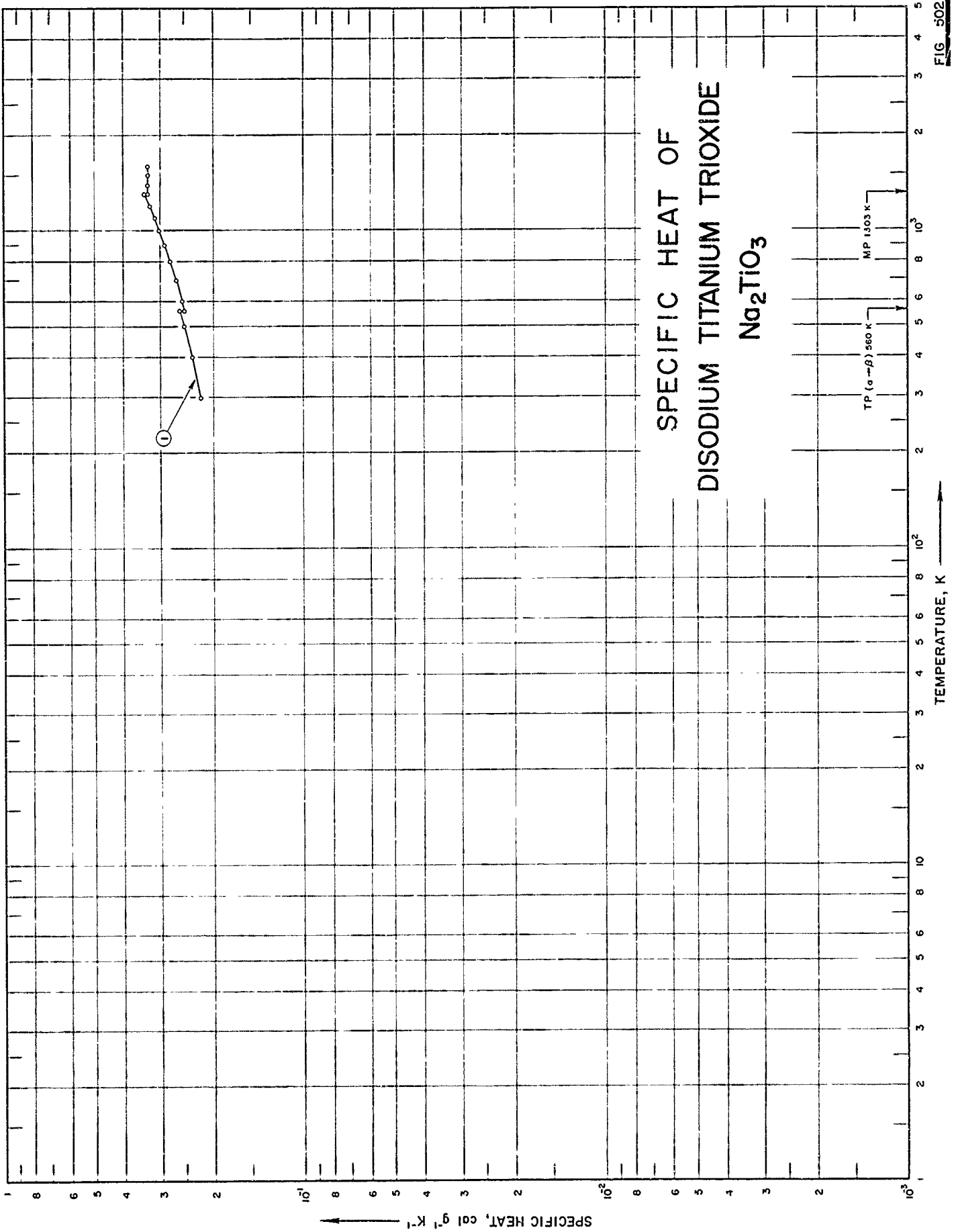

FIG. 502

SPECIFICATION TABLE NO. 502 SPECIFIC HEAT OF DISODIUM TITANIUM TRIOXIDE Na_2TiO_3

[For Data Reported in Figure and Table No. 502]

Curve No.	Ref. No.	Year	Temp. Range, K	Reported Error, %	Name and Specimen Designation	Composition (weight percent), Specifications and Remarks
1	404	1945	298-1600			98.4 Na_2TiO_3 ; prepared by treating stoichiometric weights of Na_2CO_3 (prepared from reagent-grade NaHCO_3) with TiO_2 ; heated for several hrs with constant pumping to remove CO_2 .

DATA TABLE NO. 562 SPECIFIC HEAT OF DISODIUM TITANIUM TRIOXIDE Na_2TiO_3 [Temperature, T, K; Specific Heat, C_p , Cal $\text{g}^{-1}\text{K}^{-1}$]

T	C_p
	<u>CURVE 1</u>
298.15	2.210 x 10 ⁻¹
300	2.213*
400	2.359
500	2.505
(α) 560	2.592
(β) 560	2.500
600	2.548
700	2.667
800	2.787
900	2.907
1000	3.027
1100	3.147
1200	3.266
1300	3.386*
(β) 1303	3.390
(γ) 1303	3.305
1400	3.305
1500	3.305
1600	3.305

* Not shown on plot

SPECIFIC HEAT OF
DISODIUM DITITANIUM PENTAOXIDE
 $\text{Na}_2\text{Ti}_2\text{O}_5$

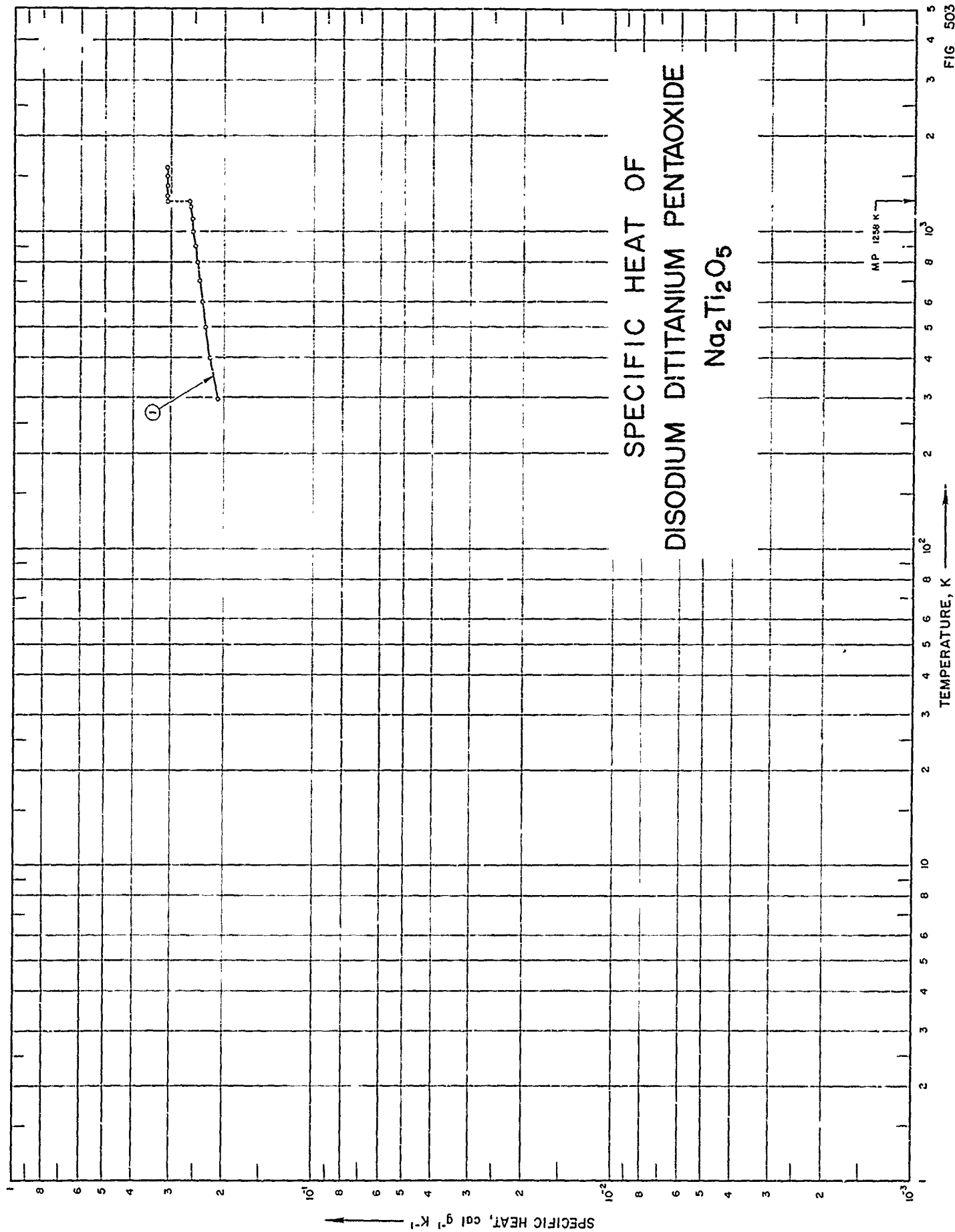

SPECIFICATION TABLE NO. 503 SPECIFIC HEAT OF DISODIUM DITITANIUM PENTAOXIDE $\text{Na}_2\text{Ti}_2\text{O}_5$

[For Data Reported in Figure and Table No. 503]

Curve No.	Ref. No.	Year	Temp. Range, K	Reported Error, %	Name and Specimen Designation	Composition (weight percent), Specifications and Remarks
1	404	1945	298-1600			98.9 $\text{Na}_2\text{Ti}_2\text{O}_5$; prepared by treating stoichiometric weights of Na_2CO_3 (prepared from reagent-grade NaHCO_3) with 98.6 pure TiO_2 ; heated several hrs at 900-1100 C with constant pumping to remove CO_2 .

DATA TABLE NO. 503 SPECIFIC HEAT OF DISODIUM DITITANIUM PENTAOXIDE $\text{Na}_2\text{Ti}_2\text{O}_6$ [Temperature, T, K; Specific Heat, C_p , Cal $\text{g}^{-1}\text{K}^{-1}$]

T	C_p
CURVE 1	
298.15	2.085×10^{-1}
300	2.089*
400	2.221
500	2.300
600	2.357
700	2.404
800	2.446
900	2.485
1000	2.521
1100	2.557
1200	2.591
(s) 1258	2.611
(L) 1258	3.088
1300	3.088
1400	3.088
1500	3.088
1600	3.088

* Not shown on plot

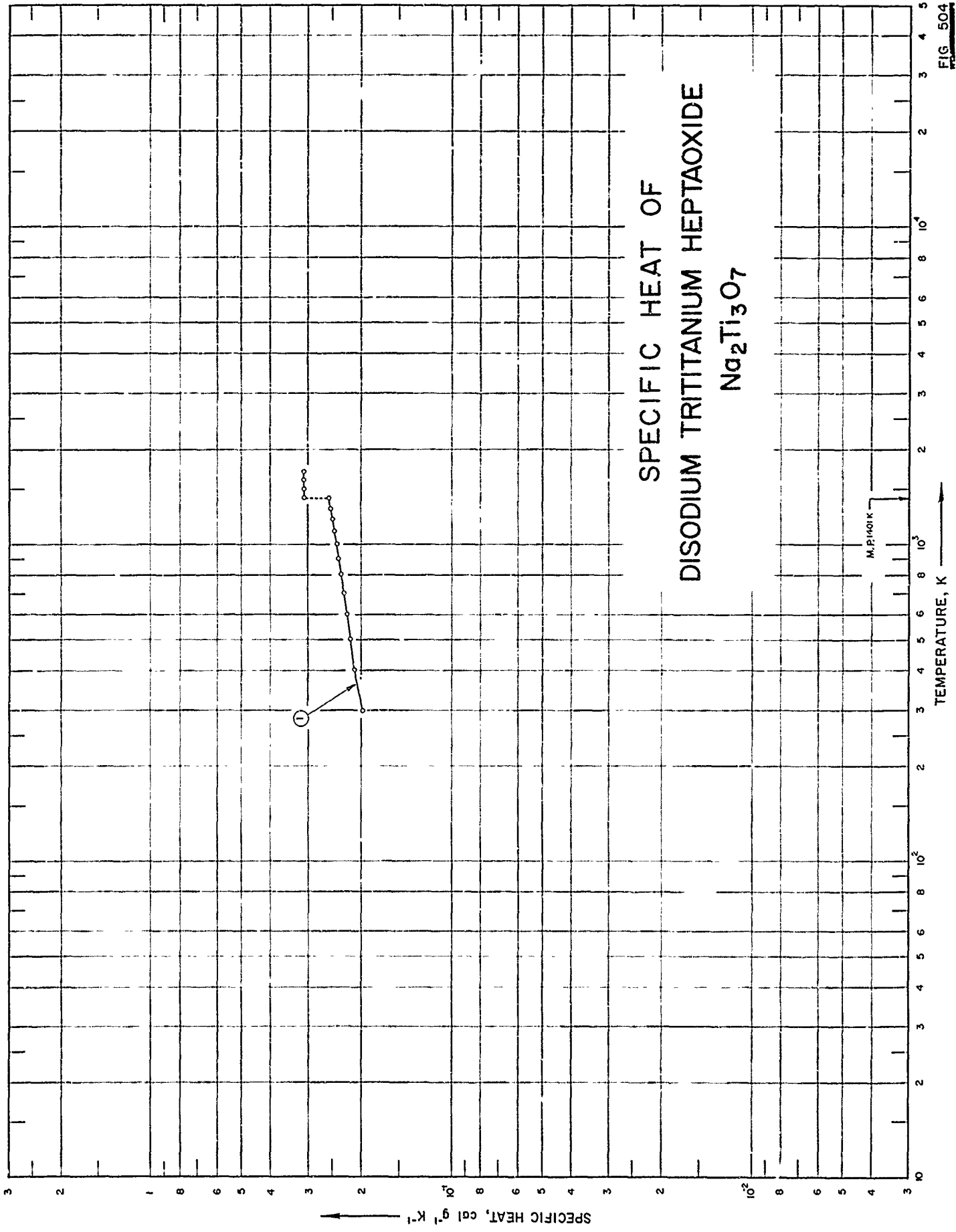

FIG. 504

SPECIFICATION TABLE NO. 504 SPECIFIC HEAT OF DISODIUM TRITITANIUM HEPTAOXIDE $\text{Na}_2\text{Ti}_3\text{O}_7$

[For Data Reported in Figure and Table No. 504]

Curve No.	Ref. No.	Year	Temp. Range, K	Reported Error, %	Name and Specimen Designation	Composition (weight percent), Specifications and Remarks
1	404	1945	298-1760			98.6 $\text{Na}_2\text{Ti}_3\text{O}_7$; prepared by treating stoichiometric weights Na_2CO_3 (prepared from reagent-grade NaHCO_3) with 98.6 pure TiO_2 ; heated several hrs with constant pumping to remove CO_2 .

DATA TABLE NO. 504 SPECIFIC HEAT OF DISODIUM TRITANTANUM HEPTAOXIDE $\text{Na}_2\text{Ti}_3\text{O}_7$ [Temperature, T, K; Specific Heat, C_p , Cal $\text{g}^{-1}\text{K}^{-1}$]

T	C_p
<u>CURVE 1</u>	
298	1.988×10^{-1}
300	2.001*
400	2.128
500	2.205
600	2.263
700	2.312
800	2.356
900	2.398
1000	2.437
1100	2.476
1200	2.514
1300	2.551
(s) 1401	2.588
(c) 1401	3.121
1500	3.121
1600	3.121
1700	3.121

* Not shown on plot

SPECIFIC HEAT OF
DISODIUM TUNGSTEN TETRAOXIDE
Na2WO4

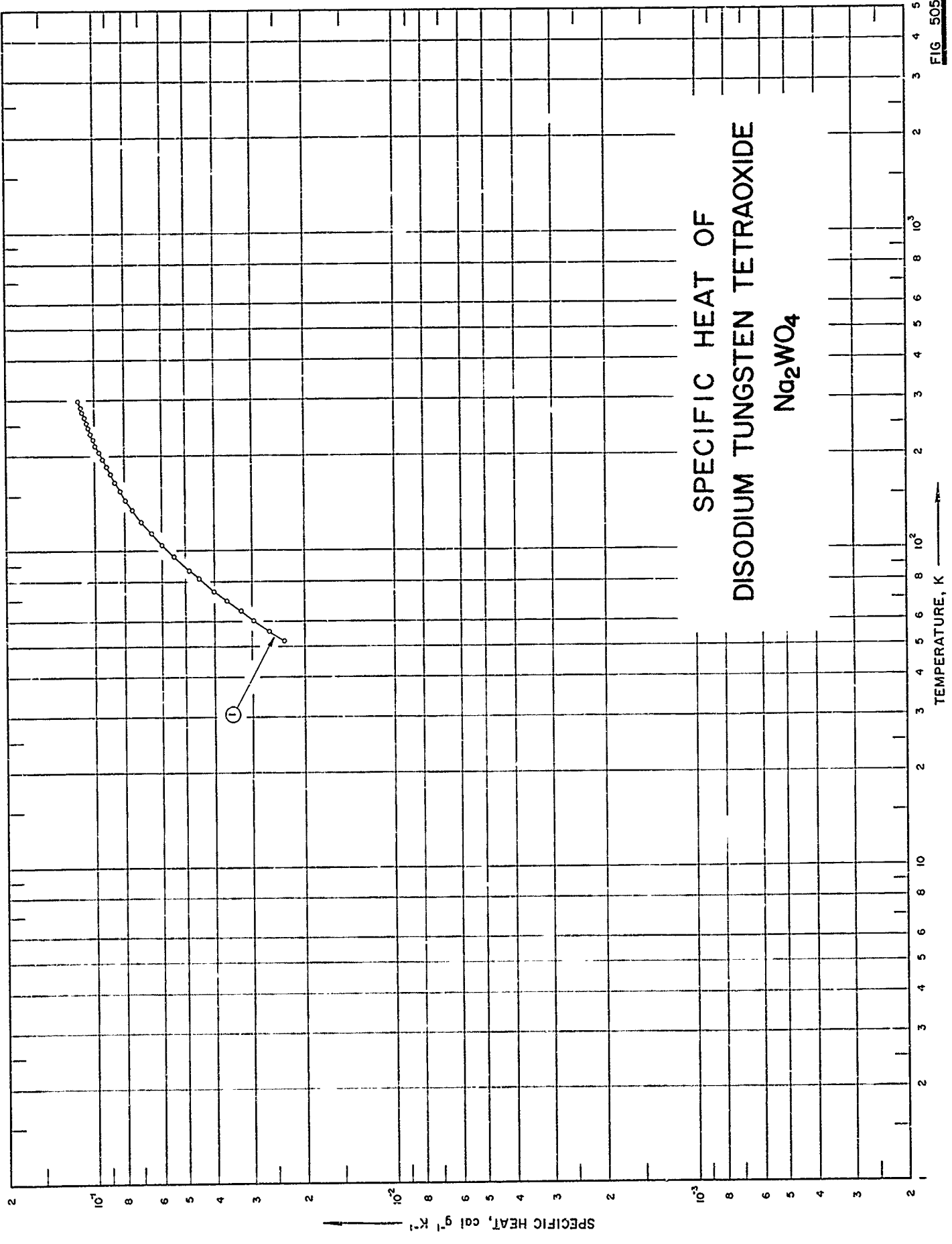

SPECIFICATION TABLE NO. 505 SPECIFIC HEAT OF DISODIUM TUNGSTEN TETRAOXIDE Na_2WO_4

[For Data Reported in Figure and Table No. 505]

Curve No.	Ref. No.	Year	Temp. Range, K	Reported Error, %	Name and Specimen Designation	Composition (weight percent), Specifications and Remarks
1	375	1961	52-300	0.3		78.95 WO_3 ; prepared by melting twice stoichiometric mixture of reagent-grade sodium carbonate and tungstic acid; heated 4 times for total of 4.5 days at 460-600 C.

DATA TABLE NO. 505 SPECIFIC HEAT OF DISODIUM TUNGSTEN TETRAOXIDE Na_2WO_4 [Temperature, T, K; Specific Heat, C_p , Cal $\text{g}^{-1}\text{K}^{-1}$]

T	C_p
CURVE 1	
52.01	2.358×10^{-2}
55.97	2.644
60.42	2.974
64.83	3.298
69.61	3.658
74.62	4.026
82.13	4.506
86.81	4.860
95.18	5.397
105.12	5.983
114.65	6.497
124.74	6.990
136.04	7.501
146.02	7.909
155.91	8.277
166.07	8.600
176.07	8.899
186.09	9.185
196.09	9.430
206.18	9.682
216.29	9.954
226.34	1.013×10^{-1}
236.20	1.032
246.06	1.051
256.61	1.070
266.80	1.087
276.49	1.103
286.66	1.118
296.07	1.133*
299.87	1.140

* Not shown on plot

SPECIFIC HEAT OF
DISODIUM DITUNGSTEN HEPTAOXIDE
 $\text{Na}_2\text{W}_2\text{O}_7$

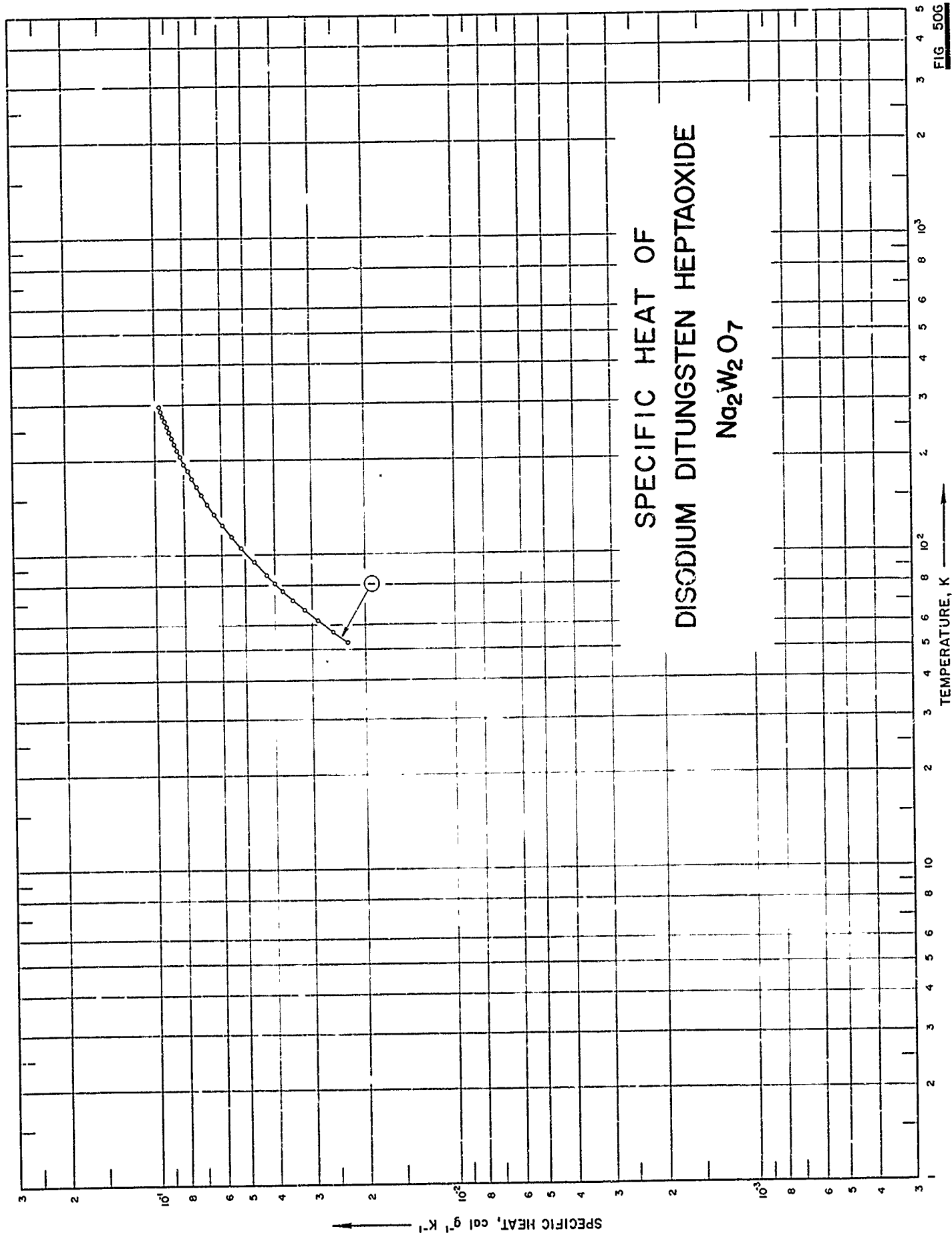

FIG. 50G

SPECIFICATION TABLE NO. 506 SPECIFIC HEAT OF DISODIUM DITUNGSTEN HEPTAOXIDE $\text{Na}_2\text{W}_2\text{O}_7$

[For Data Reported in Figure and Table No. 506]

Curve No.	Ref. No.	Year	Temp. Range, K	Reported Error, %	Name and Specimen Designation	Composition (weight percent), Specifications and Remarks
1	401	1963	53-296	0.3		87.78 WO_3 , 0.24 Al_2O_3 , 0.24 SiO_2 , 11.79 Na_2O .

DATA TABLE NO. 506 SPECIFIC HEAT OF DISODIUM DITUNGSTEN HEPTAOXIDE $\text{Na}_2\text{W}_7\text{O}_4$ [Temperature, T, K; Specific Heat, C_p , Cal $\text{g}^{-1}\text{K}^{-1}$]

T	C_p
CURVE 1	$\times 10^{-2}$
52.75	2.311
56.90	2.574
61.80	2.897
66.79	3.198
71.66	3.487
76.59	3.772
81.02	4.018
86.14	4.292
94.64	4.697
104.99	5.205
114.68	5.625
124.69	6.023
135.84	6.430
145.61	6.753
155.71	7.056
165.64	7.330
176.25	7.602
185.99	7.832
195.89	8.056
206.21	8.265
216.05	8.465
226.27	8.657
236.05	8.834
245.79	9.000
256.20	9.169
266.47	9.319
276.31	9.468
286.84	9.609
296.26	9.744

FIG. 507

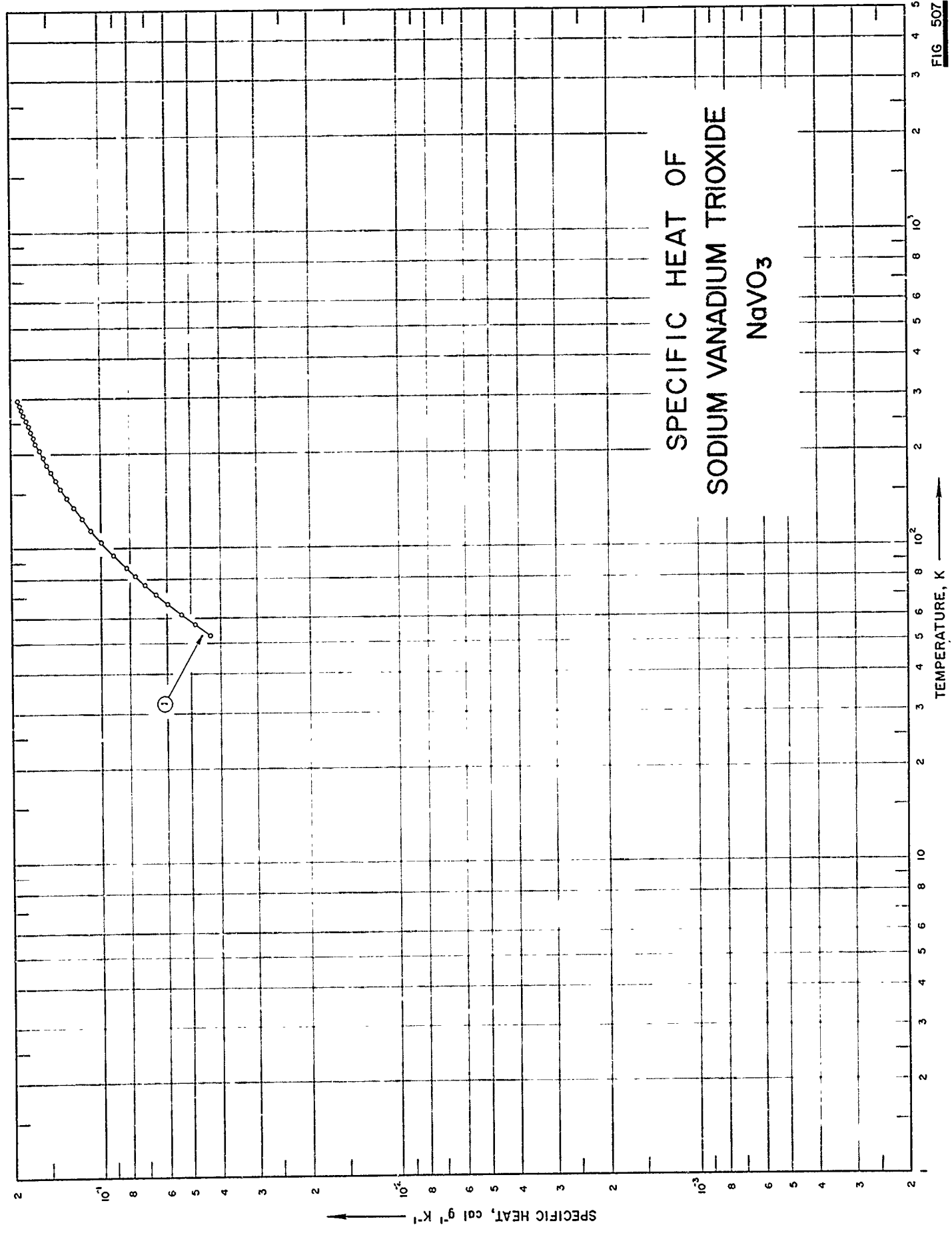

SPECIFICATION TABLE NO. 507 SPECIFIC HEAT OF SODIUM VANADIUM TRIOXIDE NaVO_3

[For Data Reported in Figure and Table No. 507]

Curve No.	Ref. No.	Year	Temp. Range, K	Reported Error, %	Name and Specimen Designation	Composition (weight percent), Specifications and Remarks
1	405	1961	53-296	0.3		99.8 NaVO_3 ; heated at 500 C for 3 hrs.

DATA TABLE NO. 507 SPECIFIC HEAT OF SODIUM VANADIUM TRIOXIDE NaVO_3
 [Temperature, T, K; Specific Heat, C_p , Cal $\text{g}^{-1}\text{K}^{-1}$]

T	C_p
CURVE 1	
52.79	4.345×10^{-2}
57.22	4.876
61.86	5.433
66.61	6.006
71.57	6.593
76.62	7.168
81.88	7.745
86.80	8.258
94.20	9.119
104.92	1.002×10^{-1}
114.95	1.087
124.87	1.166
136.07	1.246
146.32	1.315
155.97	1.375
165.95	1.427
176.02	1.479
186.02	1.527
196.00	1.570
206.17	1.614
217.57	1.661
226.10	1.692
236.30	1.728
246.28	1.758
256.65	1.794
266.75	1.825
276.68	1.853
286.85	1.880
296.36	1.908

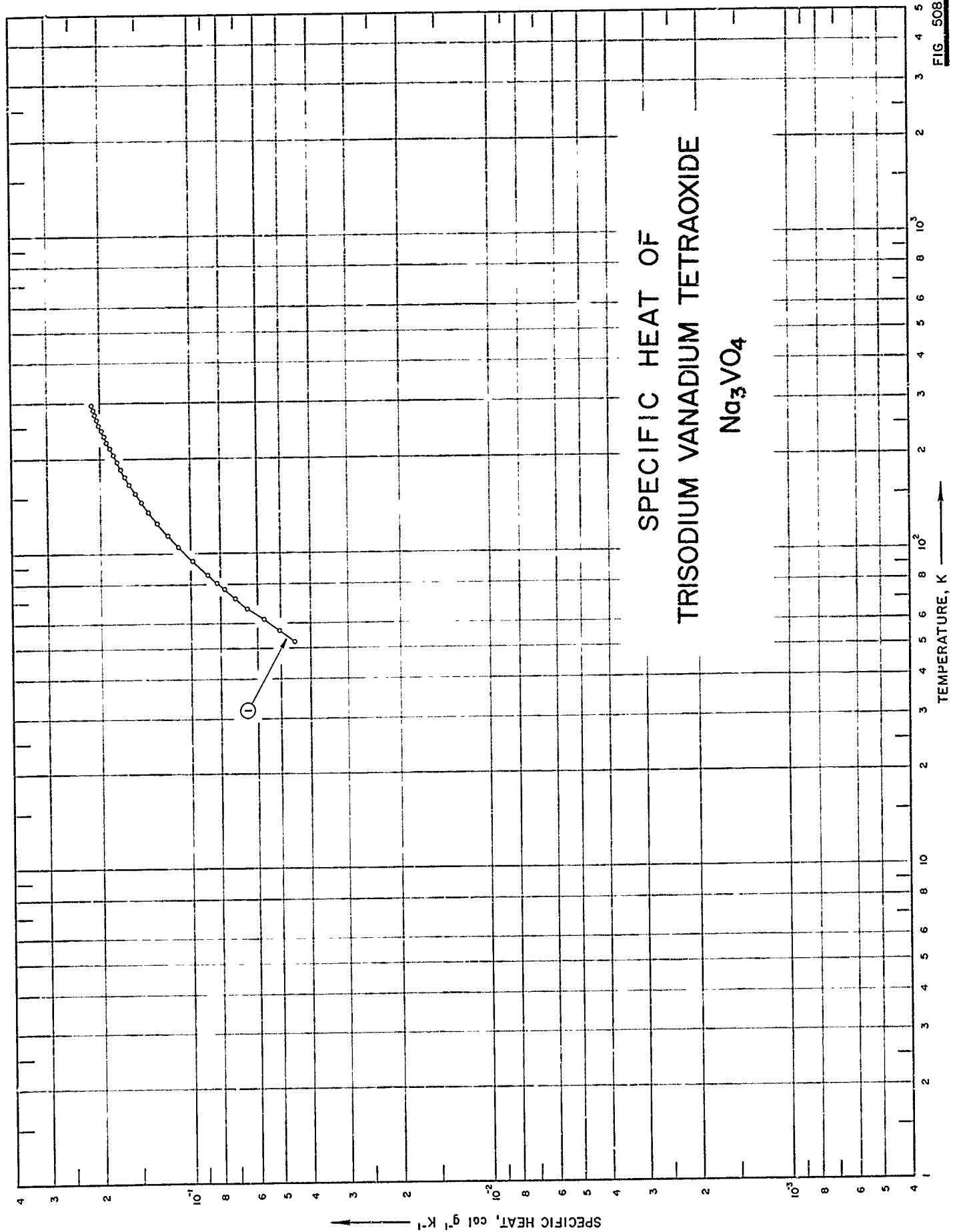

SPECIFICATION TABLE NO. 508 SPECIFIC HEAT OF TRISODIUM VANADIUM TETRAOXIDE Na_3VO_4

[For Data Reported in Figure and Table No. 508]

Curve No.	Ref. No.	Year	Temp. Range, K	Reported Error, %	Name and Specimen Designation	Composition (weight percent)	Specifications and Remarks
1	405	1961	53-2°	0.3		99.8 Na_3VO_4 ; heated 5 hrs at 725 C.	

DATA TABLE NO. 508 SPECIFIC HEAT OF TRISODIUM VANADIUM TETRAOXIDE Na_3VO_4 [Temperature, T, K; Specific Heat, C_p , Cal $\text{g}^{-1}\text{K}^{-1}$]

T	C_p
CURVE 1	
52.59	4.526×10^{-2}
56.96	5.085
61.73	5.725
66.78	6.465
71.99	7.095
77.11	7.742
80.52	8.194
85.48	8.803
94.84	9.896
105.64	1.108×10^{-1}
114.60	1.196
125.33	1.296
236.18	1.389
145.64	1.463
155.79	1.535
165.90	1.601
175.96	1.660
186.11	1.718
196.17	1.766
206.26	1.808
216.04	1.862
226.37	1.903
236.32	1.944
245.84	1.977
256.42	2.021
266.26	2.051
276.28	2.081
286.40	2.107
295.99	2.140

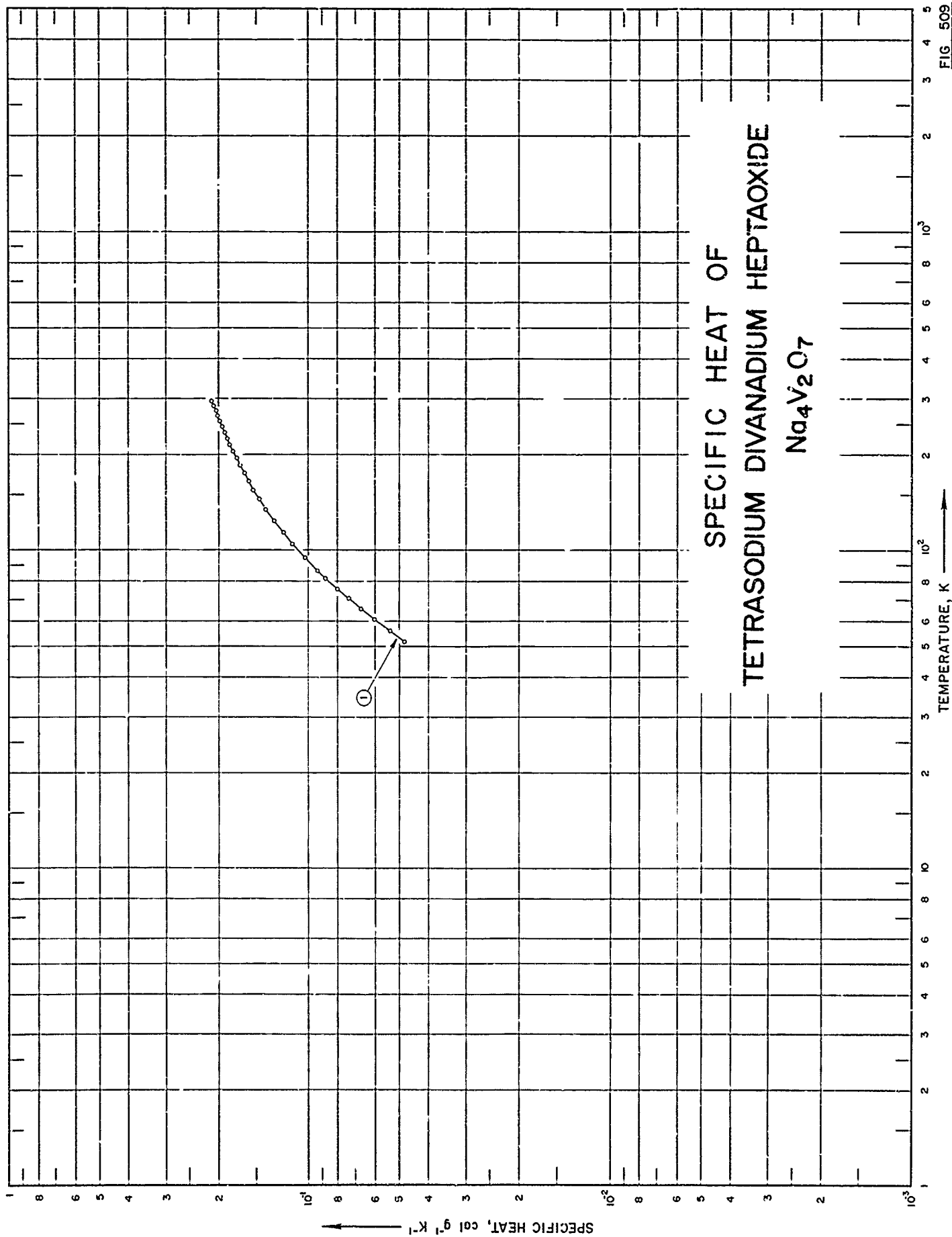

SPECIFICATION TABLE NO. 509 SPECIFIC HEAT OF TETRASODIUM DIVANADIUM HEPTAOXIDE $\text{Na}_4\text{V}_2\text{O}_7$

[For Data Reported in Figure and Table No. 509]

Curve No.	Ref. No.	Year	Temp. Range, K	Reported Error, %	Name and Specimen Designation	Composition (weight percent), Specifications and Remarks
1	405	1961	52-296	0.3		99.8 $\text{Na}_4\text{V}_2\text{O}_7$; heated for 5 hrs at 500 C.

DATA TABLE NO. 509 SPECIFIC HEAT OF TETRASODIUM DIVANADIUM HEPTAOXIDE $\text{Na}_4\text{V}_2\text{O}_7$ [Temperature, T, K; Specific Heat, C_p , Cal $\text{g}^{-1}\text{K}^{-1}$]

T	C_p
	CURVE 1
51.93	4.816×10^{-2}
56.04	5.372
60.88	6.035
65.77	6.712
70.77	7.389
75.83	8.030
81.99	8.792
86.65	9.341
94.83	1.025×10^{-1}
105.03	1.130
114.56	1.218
124.75	1.306
135.88	1.392
145.79	1.464
155.95	1.530
166.00	1.589
176.16	1.644
186.13	1.695
195.97	1.738
206.33	1.787
216.28	1.830
226.28	1.869
236.40	1.907
245.90	1.940
256.47	1.979
266.46	2.011
276.14	2.038
286.76	2.074
296.94	2.104

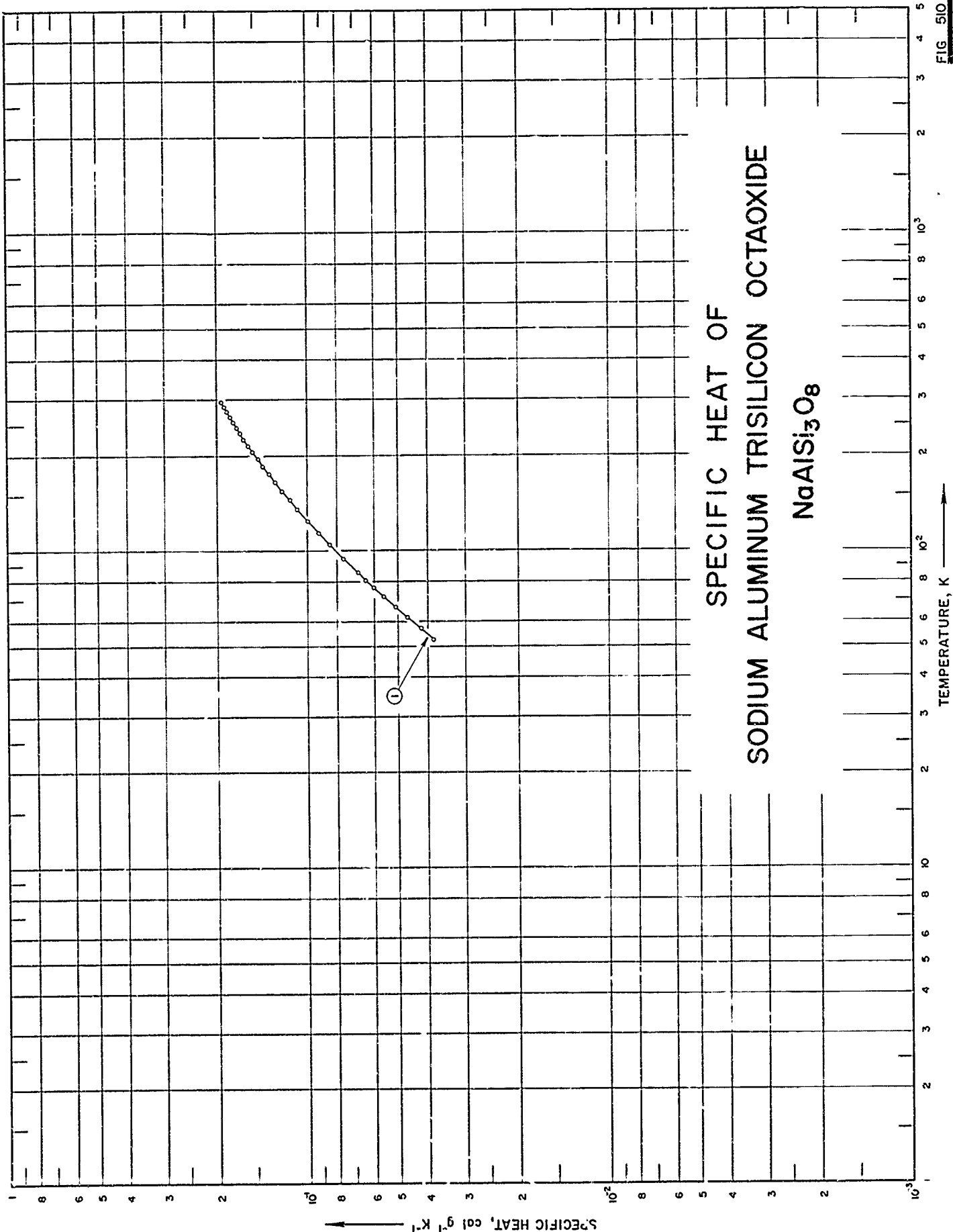

SPECIFIC HEAT OF
SODIUM ALUMINUM TRISILICON OCTAOXIDE
NaAlSi₃O₈

SPECIFICATION TABLE NO. 510 SPECIFIC HEAT OF SODIUM ALUMINUM TRISILICON OCTAOXIDE $\text{NaAlSi}_3\text{O}_8$

[For Data Reported in Figure and Table No. 510]

Curve No.	Ref. No.	Year	Temp. Range, K	Reported Error, %	Name and Specimen Designation	Composition (weight percent). Specifications and Remarks
1	380	1961	53-297		Dehydrated anatase	56.05 SiO_2 , 22.36 Al_2O_3 , 13.44 Na_2O , 8.13 combined H_2O , 0.10 K_2O , 0.02 MgO , 0.01 TiO_2 , 0.03 Fe_2O_3 , 0.01 absorbed H_2O , ~0.005 CaO ; water free basis: 61.01 SiO_2 , 24.34 Al_2O_3 , 14.63 Na_2O , 0.11 K_2O , 0.03 Fe_2O_3 , 0.02 MgO , 0.01 TiO ; prepared from anatase; heated at 500 C for 20 hrs.

DATA TABLE NO. 510 SPECIFIC HEAT OF SODIUM ALUMINUM TRISILICON OCTAOXIDE $\text{NaAlSi}_3\text{O}_8$
 [Temperature, T, K; Specific Heat, C_p , Cal $\text{g}^{-1}\text{K}^{-1}$]

T	C_p
CURVE 1	
52.67	3.805×10^{-2}
57.33	4.226
61.98	4.670
66.76	5.120
71.63	5.575
76.61	6.020
80.97	6.411
85.51	6.812
94.76	7.603
105.02	8.464
114.52	9.211
124.81	9.998
136.04	1.083×10^{-1}
145.74	1.152
155.94	1.223
165.90	1.285
176.07	1.349
186.30	1.412
196.11	1.466
206.26	1.525
216.39	1.577
226.27	1.629
236.11	1.676
245.69	1.720
256.75	1.770
266.60	1.813
276.81	1.855
286.77	1.896
296.59	1.933

FIG. 511

SPECIFIC HEAT OF STRONTIUM SILICON TRIOXIDE SrSiO3

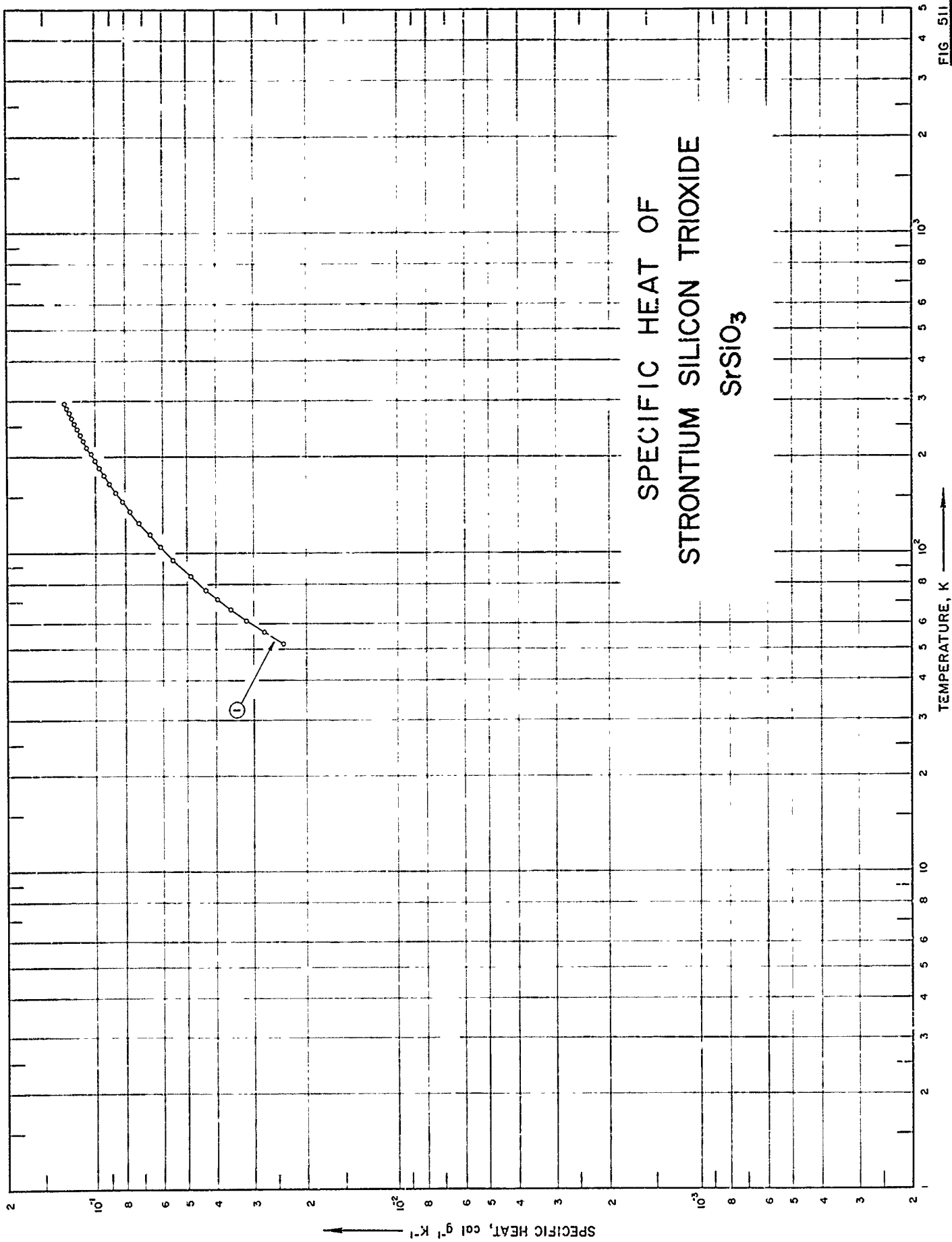

SPECIFICATION TABLE NO. 511 SPECIFIC HEAT OF STRONTIUM SILICON TRIOXIDE SrSiO_3

[For Data Reported in Figure and Table No. 511]

Curve No.	Ref. No.	Year	Temp. Range, K	Reported Error, %	Name and Specimen Designation	Composition (weight percent), Specifications and Remarks
1	360	1964	52-296			63.26 SrO, 36.66 SiO_2 (63.30, 36.70 theo.), 0.12 Al_2O_3 .

DATA TABLE NO. 511 SPECIFIC HEAT OF STRONTIUM SILICON TRIOXIDE SrSiO₃Temperature, T, K; Specific Heat, C_p, Cal g⁻¹K⁻¹

T	C _p
CURVE 1	
52.11	2.422 x 10 ⁻²
56.58	2.786
61.50	3.202
66.84	3.613
71.95	3.999
76.71	4.354
80.07	4.594
84.75	4.912
95.48	5.600
105.23	6.194
114.96	6.744
124.81	7.269
135.83	7.825
145.64	8.277
155.71	8.717
166.07	9.133
176.11	9.524
186.13	9.878
196.14	1.021 x 10 ⁻¹
206.24	1.054
216.52	1.086
226.28	1.116
236.34	1.145
245.94	1.171
256.35	1.196
266.58	1.222
276.55	1.246
286.92	1.269
296.39	1.289

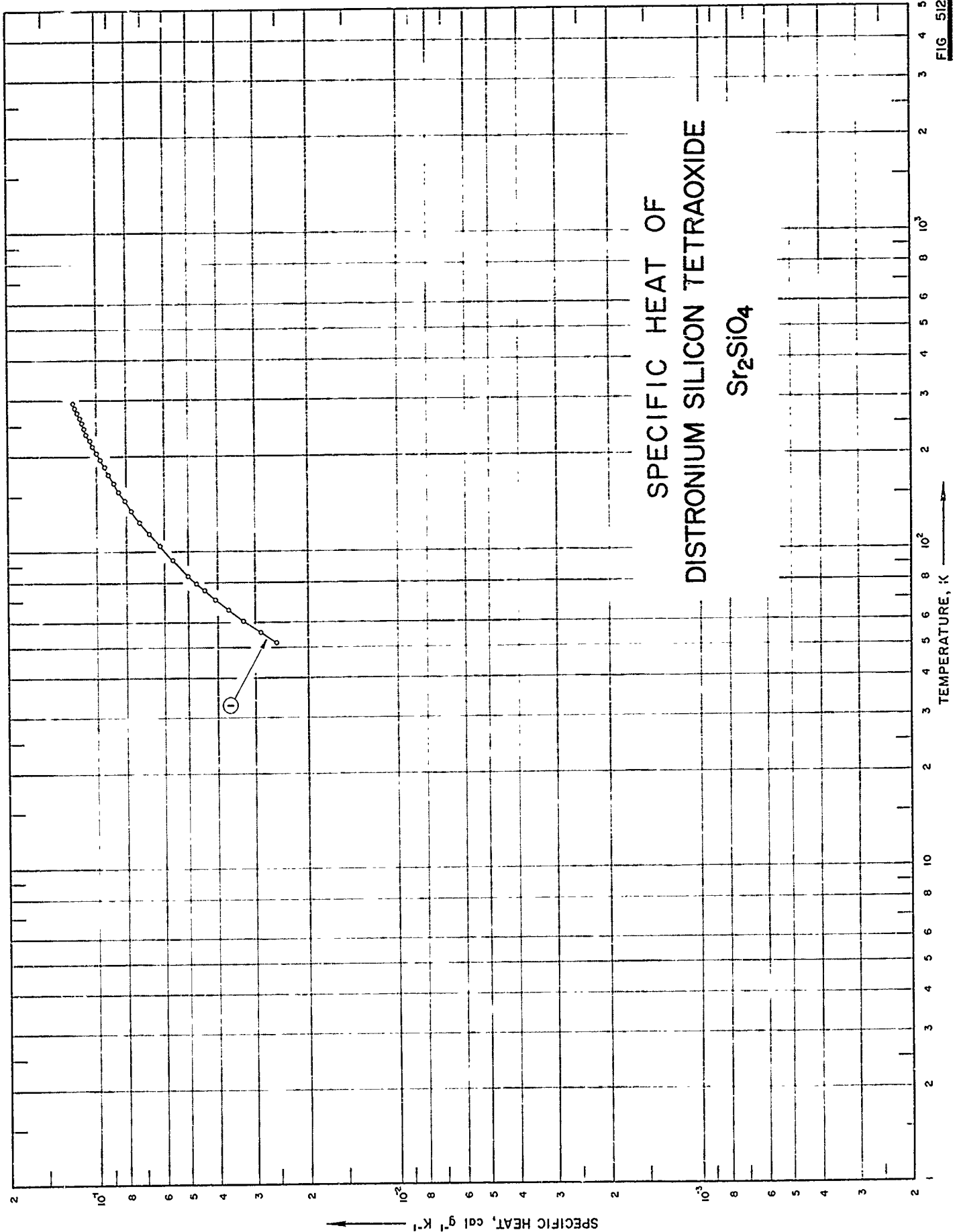

FIG 512

SPECIFICATION TABLE NO. 512 SPECIFIC HEAT OF DISTRONTIUM SILICON TETRAOXIDE Sr_2SiO_4

[For Data Reported in Figure and Table No. 512]

Curve No.	Rel. No.	Year	Temp. Range, K	Reported Error, %	Name and Specimen Designation	Composition (weight percent). Specifications and Remarks
1	360	1964	52-296			77.51 SrO, 22.47 SiO ₂ (77.53, 22.47 theo.).

DATA TABLE NO. 512 SPECIFIC HEAT OF DISTRONTIUM SILICON TETRAOXIDE Sr_2SiO_4 [Temperature, T.K; Specific Heat, C_p , Cal $\text{g}^{-1}\text{K}^{-1}$]

T	<u>CURVE 1</u>	C_p
51.99		2.56×10^{-2}
55.84		2.88
60.56		3.28
65.62		3.68
70.64		4.06
75.67		4.42
79.56		4.71
84.08		5.01
89.41		5.64
105.13		6.23
114.68		6.73
124.70		7.22
135.78		7.70
145.63		8.09
155.69		8.47
166.25		8.83
176.10		9.15
185.94		9.44
195.97		9.74
206.15		1.00×10^{-1}
216.35		1.02
226.09		1.05
236.24		1.08
245.78		1.10
256.45		1.12
266.39		1.14
276.53		1.16
286.74		1.18
296.27		1.20

FIG 513

SPECIFIC HEAT OF
STRONTIUM TITANIUM TRIOXIDE
SrTiO3

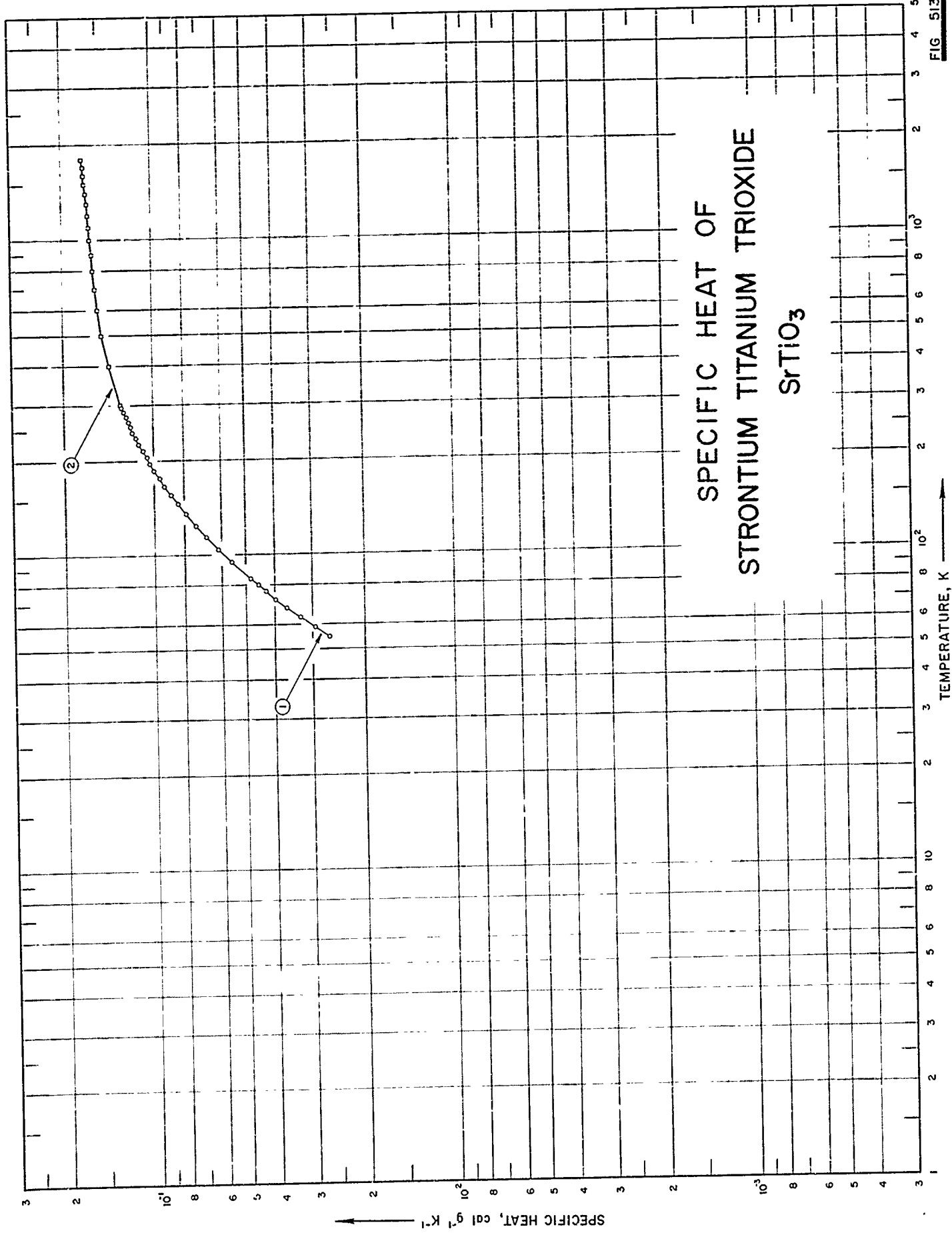

SPECIFICATION TABLE NO. 513 SPECIFIC HEAT OF STRONTIUM TITANIUM TRIOXIDE SrTiO_3

[For Data Reported in Figure and Table No. 513]

Curve No.	Ref. No.	Year	Temp. Range, K	Reported Error, %	Name and Specimen Designation	Composition (weight percent), Specifications and Remarks
1	362	1952	55-298			99.5 SrTiO_3 ; prepared from reagent-grade strontium carbonate and titania by prolonged heating at 1350 C.
2	361	1953	298-1800			99.5 SrTiO_3 ; prepared from reagent-grade strontium carbonate and titania by prolonged heating at 1350 C.

DATA TABLE NO. 513 SPECIFIC HEAT OF STRONTIUM TITANIUM TRIOXIDE SrTiO_3 [Temperature, T, K; Specific Heat, C_p , Cal $\text{g}^{-1}\text{K}^{-1}$]

T	C_p	
	CURVE 1	CURVE 2 (cont.)
54.84	2.639×10^{-2}	1.65×10^{-1}
58.79	2.947	1.66
63.10	3.301	1.67
67.58	3.651	1.68
71.96	3.974	1.69
76.44	4.297	1.70
80.04	4.559	
84.13	4.848	
94.62	5.552	
104.37	6.162	
114.75	6.773	
124.78	7.307	
136.25	7.912	
146.27	8.396	
156.01	8.821	
166.02	9.252	
176.15	9.644	
186.02	1.001×10^{-1}	
195.95	1.036	
206.34	1.067	
216.32	1.098	
226.26	1.127	
236.39	1.153	
247.32	1.177	
256.49	1.198	
266.22	1.219	
276.19	1.240	
286.38	1.261	
296.47	1.276*	
298.16	1.281	

CURVE 2	
298	1.28×10^{-4} *
300	1.28
400	1.42
500	1.48
600	1.53
700	1.55
800	1.58
900	1.59
1000	1.61
1100	1.62
1200	1.64

* Not shown on plot

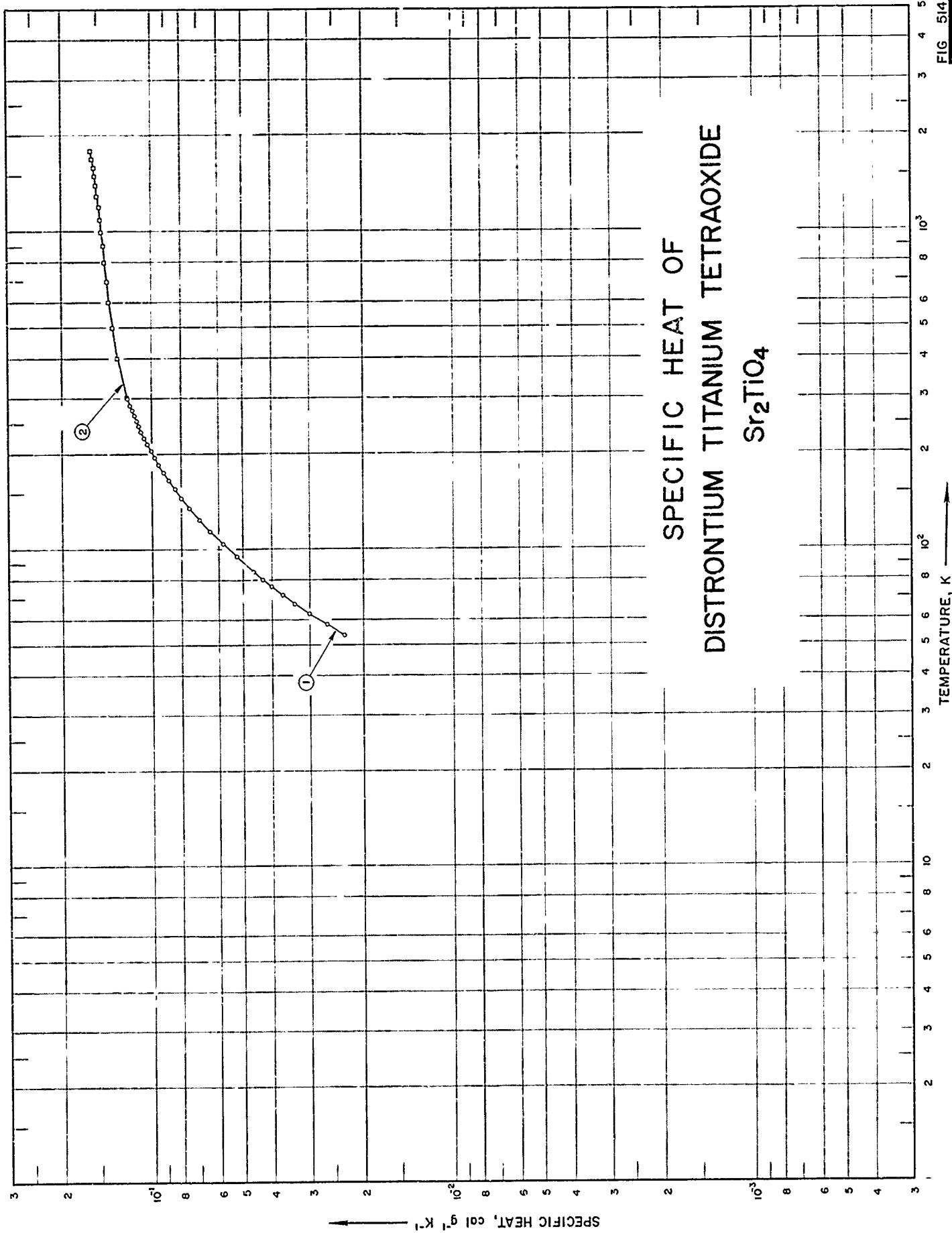

FIG 514

SPECIFICATION TABLE NO. 514 SPECIFIC HEAT OF DISTRONTIUM TITANIUM TETRAOXIDE Sr_2TiO_4

[For Data Reported in Figure and Table No. 514]

Curve No.	Ref. No.	Year	Temp. Range, K	Reported Error, %	Name and Specimen Designation	Composition (weight percent). Specifications and Remarks
1	363	1952	54-298			99.5 Sr_2TiO_4 ; 27.85 TiO_2 (27.82 theo.), 0.17 CaO, 0.03 SiO_2 .
2	361	1953	298-1800			99.5 Sr_2TiO_4 ; 27.85 TiO_2 (27.82 theo.), 0.17 CaO, 0.03 SiO_2 .

DATA TABLE NO. 514 SPECIFIC HEAT OF DISTRONTIUM TITANIUM TETRAOXIDE Sr_2TiO_4 [Temperature, T, K; Specific Heat, C_p , Cal $\text{g}^{-1}\text{K}^{-1}$]

T	C_p	T	C_p
<u>CURVE 1</u>		<u>CURVE 2 (cont.)</u>	
53.64	2.310×10^{-2}	1300	1.50×10^{-1}
58.13	2.643	1400	1.52
62.83	3.012	1500	1.53
67.41	3.366	1600	1.55
71.98	3.695	1700	1.56
76.50	4.015	1800	1.57
80.47	4.301		
85.02	4.611		
94.86	5.248		
104.69	5.836		
114.70	6.425		
124.64	6.951		
136.01	7.522		
146.00	7.982		
155.66	8.382		
165.88	8.793		
175.86	9.152		
185.92	9.486		
195.97	9.789		
206.27	1.008×10^{-1}		
216.73	1.037		
226.24	1.060		
236.33	1.082		
246.02	1.103		
255.22	1.122		
266.67	1.142		
276.38	1.160		
286.49	1.177		
296.66	1.193*		
298.16	1.196		
<u>CURVE 2</u>			
298	1.20×10^{-1}		
300	1.20		
400	1.29		
500	1.34		
600	1.37		
700	1.40		
800	1.42		
900	1.44		
1000	1.46		
1100	1.47		
1200	1.49		

* Not shown on plot

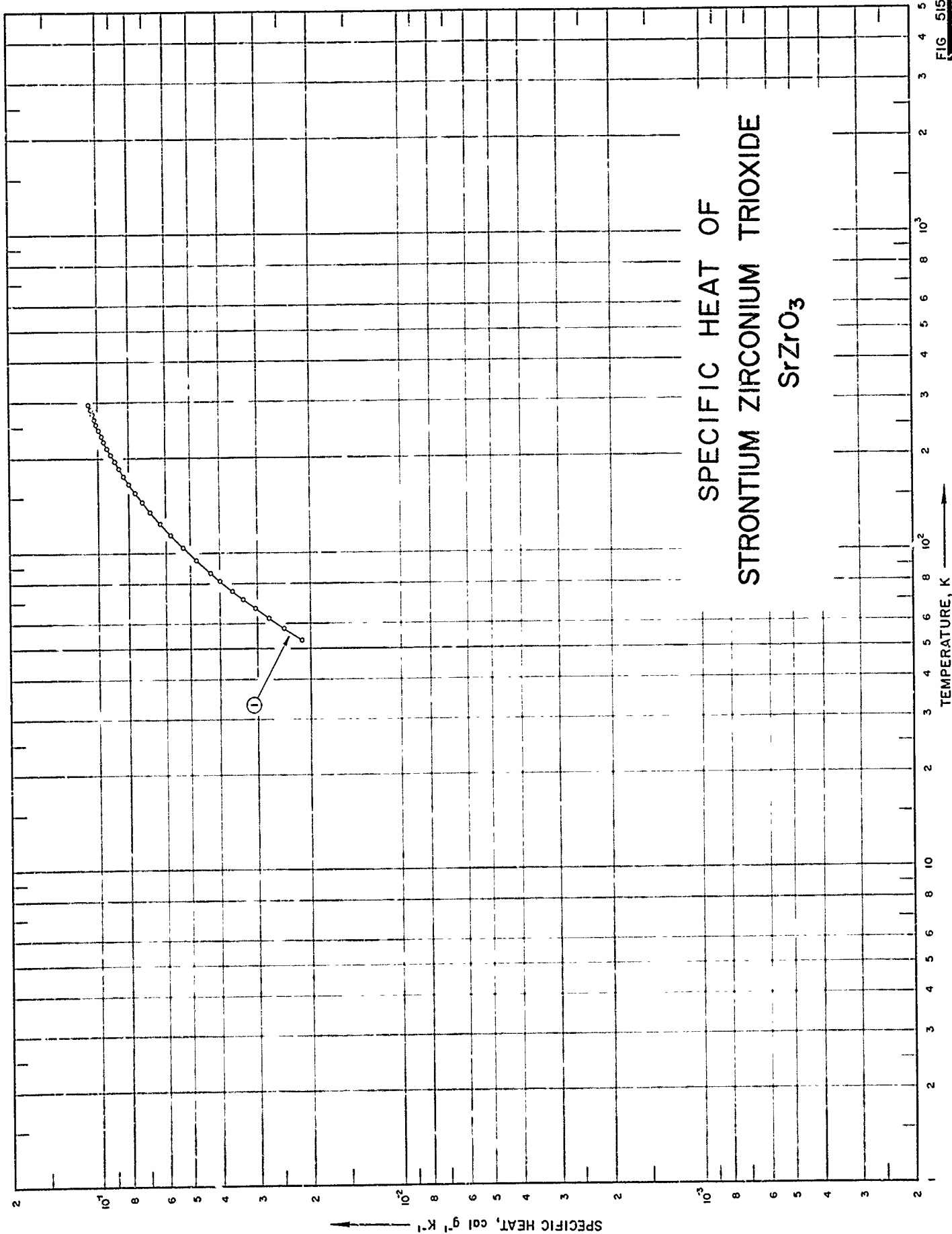

SPECIFICATION TABLE NO. 515 SPECIFIC HEAT OF STRONTIUM ZIRCONIUM TRIOXIDE SrZrO_3

[For Data Reported in Figure and Table No. 515]

Curve No.	Ref. No.	Year	Temp. Range, K	Reported Error, %	Name and Specimen Designation	Composition (weight percent). Specifications and Remarks
1	364	1960	53-296	0.3		54.32 ZrO_2 , 45.56 SrO (54.32, 45.68 theo.); prepared by heating reagent-grade strontium carbonate and pure zirconia for 24 hrs at 1000 C, 6 hrs at 1350-1400 C, 8 hrs at 1350-1470 C, and 12 hrs at 1300-1380 C.

DATA TABLE NO. 515 SPECIFIC HEAT OF STRONTIUM ZIRCONIUM TRIOXIDE SrZrO_3 Temperature, T, K; Specific Heat, C_p , Cal g⁻¹K⁻¹

T	C_p
CURVE 1	
53.44	2.145×10^{-2}
57.97	2.454
62.44	2.758
67.07	3.065
71.51	3.353
76.19	3.618
81.72	3.935
86.63	4.286
94.94	4.770
104.94	5.325
114.82	5.823
124.49	6.290
136.28	6.833
146.12	7.247
156.12	7.631
166.15	7.988
176.50	8.314
185.91	8.614
195.88	8.883
206.07	9.165
215.81	9.407
225.91	9.650
235.82	9.843
245.65	1.003×10^{-1}
256.16	1.023
265.90	1.040
275.94	1.055
286.17	1.071
295.79	1.086

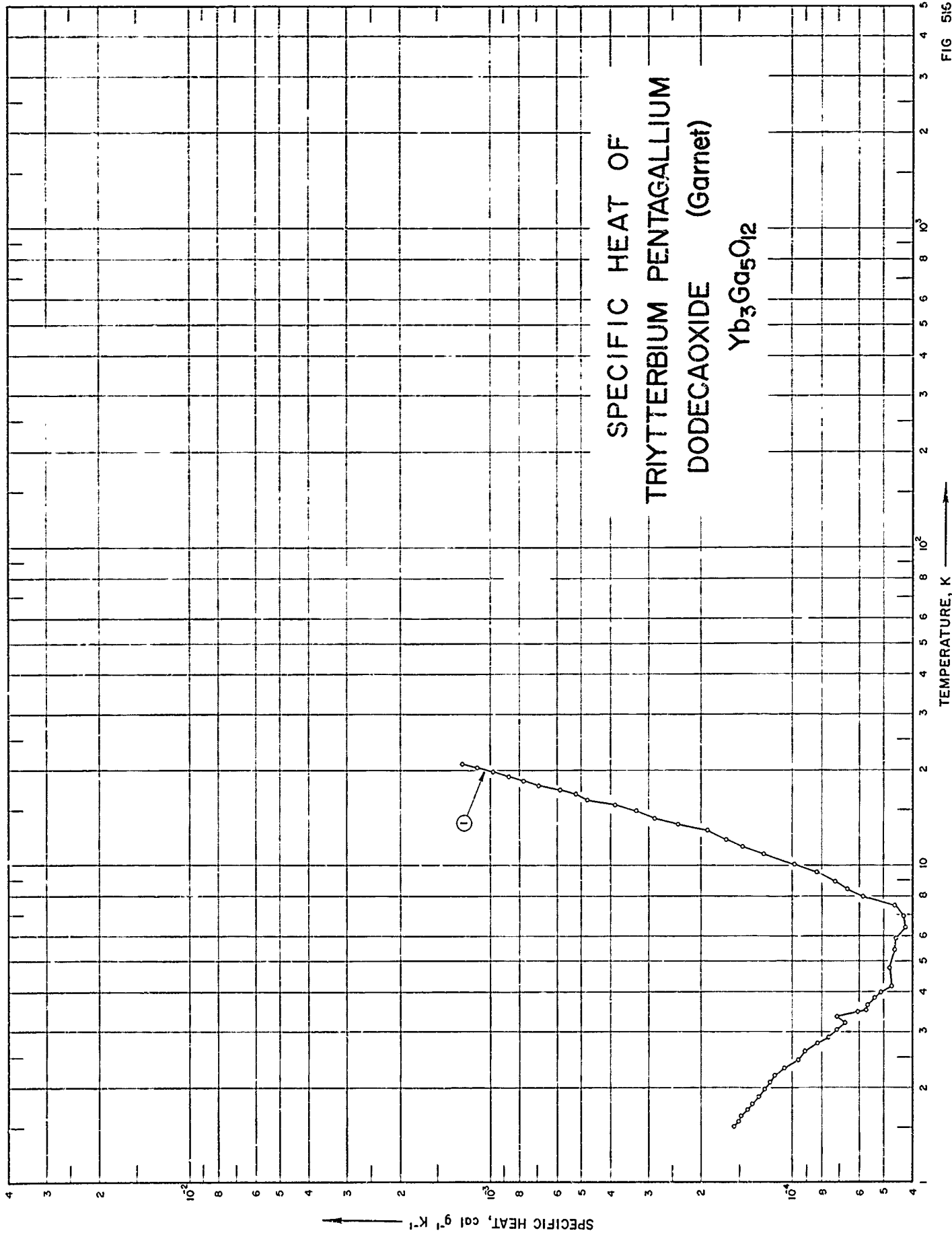

FIG. 516

SPECIFICATION TABLE NO. 516 SPECIFIC HEAT OF TRIYTTTERBIUM PENTAGALLIUM DODECAOXIDE, $\text{Yb}_3\text{Ga}_5\text{O}_{12}$ (Garnet)

[For Data Reported in Figure and Table No. 516]

Curve No.	Ref. No.	Year	Temp. Range, K	Reported Error, %	Name and Specimen Designation	Composition (weight percent), Specifications and Remarks
1	449	1963	1.5-21		Garnet	99.99 Yb_2O_3 ; supplied by Lindsay Chem.; 99.99 Ga_2O_3 ; supplied by Johnson, Matthey and Co.; direct solid state reaction of an intimate mixture of pure rare earth and gallium oxide; sintered block; polycrystalline.

DATA TABLE NO. 516 SPECIFIC HEAT OF TRITYTTERBIUM PENTAGALLIUM DODECAOXIDE, $\text{Yb}_3\text{Ga}_5\text{O}_{12}$ (Garnet)[Temperature, T, K; Specific Heat, C_p , Cal $\text{g}^{-1} \text{K}^{-1}$]

T	C_p		T	C_p
	CURVE 1	10^{-4}		
1.518	1.565	10^{-4}	14.19	2.864
1.568	1.502		14.85	3.293
1.630	1.486		15.54	3.857
1.705	1.416		16.21	4.759
1.778	1.360		16.82	5.210
1.870	1.290		17.40	5.887
1.974	1.231		17.99	6.947
2.088	1.186		18.58	7.759
2.195	1.148		19.21	8.683
2.310	1.062		19.83	9.788
2.448	9.540×10^{-5}		20.42	1.101×10^{-3}
2.612	9.067		20.94	1.238
2.766	8.255			
2.892	7.578			
3.053	7.127			
3.202	6.676			
3.350	7.127			
3.462	6.022			
3.505	5.684			
3.645	5.661			
3.675	5.593*			
3.828	5.345			
3.835	5.322			
3.995	5.052			
4.011	5.030*			
4.015	5.142*			
4.166	4.736*			
4.195	4.691			
4.78	4.759			
5.45	4.578			
5.93	4.533			
6.38	4.218			
6.94	4.285			
7.49	4.555			
7.96	5.841			
8.43	6.563			
8.93	7.240			
9.50	8.300			
10.15	9.834			
10.88	1.247×10^{-4}			
11.55	1.468			
12.19	1.655			
12.88	1.910			
13.55	2.391			

* Not shown on plot

FIG. 517

SPECIFIC HEAT OF
TRITTRIUM PENTAGALLIUM
DODECAOXIDE (Garnet)
 $Y_3Ga_5O_{12}$

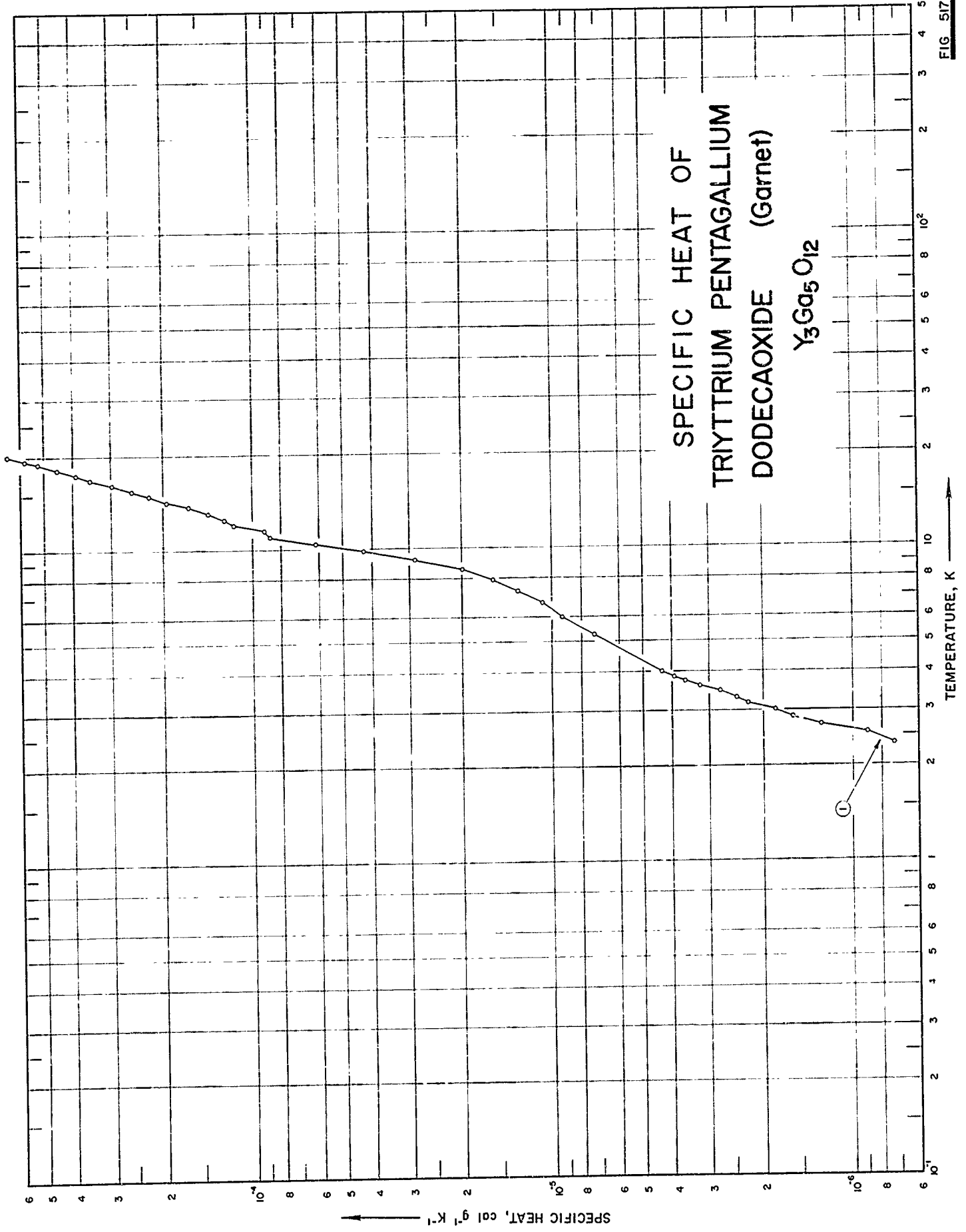

SPECIFICATION TABLE NO. 517 SPECIFIC HEAT OF TRITYTRIUM PENTAGALLIUM DODECAOXIDE, $Y_3Ga_5O_{12}$ (Garnet)

[For Data Reported in Figure and Table No. 517]

Curve No.	Ref. No.	Year	Temp. Range, K	Reported Error, %	Name and Specimen Designation	Composition (weight percent), Specifications and Remarks
1	449	1963	2.3-20		Garnet	99.99 Y_2O_3 ; supplied by Lindsay Chemical Division; 99.99 Ga_2O_3 supplied by Jolanson, Matthey and Co.; direct solid state reaction of an intimate mixture of rare earth and gallium oxide; sintered block; polycrystalline.

DATA TABLE NO. 517 SPECIFIC HEAT OF TRYTTIRIUM PENTAGALLIUM DODECAOXIDE, $Y_3Ga_5O_{12}$ (Garnet)[Temperature, T, K; Specific Heat, C_p , Cal $g^{-1}K^{-1}$]

T	C_p
CURVE 1	
2.368	7.312×10^{-7}
2.560	8.941
2.725	1.275×10^{-6}
2.885	1.587
3.042	1.818
3.193	2.223
3.338	2.439
3.480	2.765
3.625	3.227
3.766	3.611
3.893	3.937
4.020	4.322
5.32	7.224
6.03	9.207
6.73	1.075×10^{-5}
7.34	1.309
7.95	1.584
8.60	1.989
9.25	2.889
9.92	4.263
10.53	6.158
11.12	8.733
11.64	9.148
12.12	1.158×10^{-4}
12.67	1.243
13.23	1.418
13.80	1.640
14.40	1.927
15.00	2.220
15.64	2.537
16.32	2.952
17.02	3.493
17.70	3.908
18.37	4.500
19.02	5.240
19.66	5.773
20.30	6.602

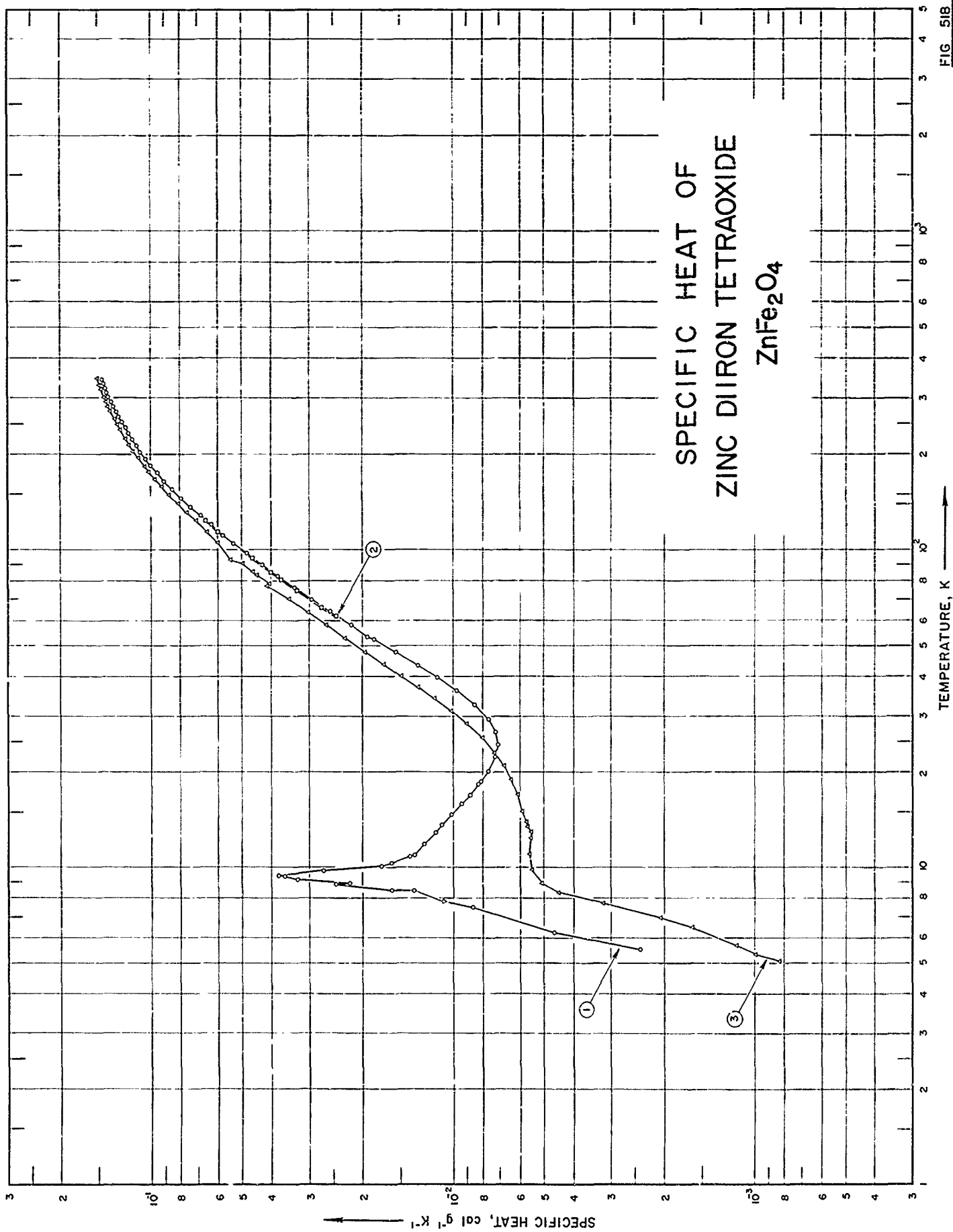

FIG. 518

SPECIFICATION TABLE NO. 518 SPECIFIC HEAT OF ZINC DIIRON TETRAOXIDE $ZnFe_2O_4$

[For Data Reported in Figure and Table No. 518]

Curve No.	Ref. No.	Year	Temp. Range, K	Reported Error, %	Name and Specimen Designation	Composition (weight percent), Specifications and Remarks
1	395	1957	6-344			46.24 \pm 0.1 Fe, 27.2 \pm 0.1 Zn (46.33, 27.12 theo.), < 0.1 ferrous Fe, 0.01-0.1 Al, 0.01-0.1 Mn, 0.001-0.01 Co, 0.001-0.01 Cu, 0.001-0.01 Ni, 0.001-0.01 Ni, 0.001-0.01 S; pressed; fired 14 hrs at 1100 C in air; fragmented to pass 30-mesh screen; reformed into slugs; fired 12 hrs at 1100 C and furnace cooled in 16 hrs.
2	382	1956	53-298		Zinc-iron Spinel	66.36 Fe_2O_3 , 33.89 ZnO; heated to 940-1280 C several times (total 18 days) with grinding and mixing between heatings.
3	406	1959	5-348			46.0 Fe, 27.0 Zn.

DATA TABLE NO. 518 SPECIFIC HEAT OF ZINC DIIRON TETRAOXIDE $ZnFe_2O_4$
 [Temperature, T, K; Specific Heat, C_p , Cal $g^{-1}K^{-1}$]

CURVE 1		CURVE 2 (cont.)		CURVE 3 (cont.)		CURVE 3 (cont.)	
T	C_p	T	C_p	T	C_p	T	C_p
Series I		Series I		Series I		Series I	
184.44	9.955×10^{-2}	15.85	9.420×10^{-3}	74.85	3.319×10^2	214.49	1.178×10^{-3}
153.52	1.037×10^{-1}	16.97	8.823	80.73	3.711	224.93	7.300
203.27	1.078	18.31	8.250	85.36	4.013	229.61	8.014
212.90	1.117	20.14	7.666	94.92	4.637	238.91	9.005
222.68	1.153	22.28	7.280	104.74	5.314*	248.35	8.893*
232.53	1.188	24.45	7.147	114.74	5.977	258.02	1.012×10^{-2}
242.39	1.221	26.74	7.255	124.74	6.629	34.14	1.155
252.28	1.251	29.39	7.666	136.03	7.339*	37.12	1.312
262.21	1.280	32.55	8.483	145.55	7.919*	40.19	1.485
272.28	1.304	36.01	9.710	155.99	8.524*	43.71	1.697
282.53	1.332	39.61	1.127×10^{-2}	166.01	9.051*	47.84	1.962
292.86	1.357	43.47	1.317	175.93	9.553*	52.66	2.285
303.14	1.379	47.72	1.551	185.96	1.002×10^{-6}	58.00	2.633
313.41	1.401	52.45	1.831	195.93	1.047*	63.60	3.029
323.41	1.420	Series IV		206.18	1.091*	70.41	3.497
333.65	1.438	17.04	8.806×10^{-3}	216.14	1.129*	78.50	4.059
343.93	1.456	18.69	8.118	225.56	1.162*	85.67	4.578
Series II		52.37	1.783×10^{-2}	236.04	1.199*	Series V	
7.81	1.1	58.05	2.176	245.76	1.229*	7.36	2.7×10^{-3}
8.47	1.6	64.00	2.561	256.44	1.263*	8.02	3.8
8.87	2.4	69.98	2.951	266.82	1.250*	8.77	5.02
9.18	3.3	76.16	3.359	276.21	1.313*	9.74	5.43
9.41	3.8	82.61	3.809	286.51	1.340*	Series III	
9.76	2.7	89.79	4.2870	295.96	1.365*	5.08	8.3×10^{-4}
10.18	1.73	97.61	4.8150	298.16	1.368*	5.12	9.1*
10.91	1.40	105.53	5.3509	CURVE 3		5.33	2.0
Series III		111.99	5.7728	Series I		5.68	1.2×10^{-3}
5.50	2.4×10^{-3}	120.25	6.3182	77.38	4.130×10^2	6.48	1.6
6.24	4.60	128.58	6.8550	83.97	4.455	6.93	2.0
6.82	6.22	137.08	7.388	90.94	4.951	7.71	3.2
7.48	8.23	146.07	7.927	93.28	5.448	8.31	4.48
8.46	1.36×10^{-2}	155.56	8.470	106.20	5.981	8.93	5.19
8.89	2.2	165.25	9.001	114.41	6.531	9.82	5.48
9.39	3.6	175.00	9.499	122.96	7.084	11.03	5.571
10.38	1.60	184.94	9.980	131.53	7.636	12.39	5.533
11.10	1.357	CURVE 2		140.24	8.079	13.82	5.724
11.82	1.259	53.26	1.933×10^{-2}	148.94	8.673	15.35	5.923*
12.95	1.156	57.63	2.186*	157.90	9.180	Series IV	
13.66	1.093	61.92	2.451	167.26	9.686	12.18	5.517×10^{-3}
14.70	1.019	66.19	2.735	176.62	1.015×10^{-1}	13.44	5.691
		70.51	3.033*	183.62	1.048	15.07	5.927
				195.05	1.099	17.03	6.110
				204.89	1.140	18.94	6.413

* Not shown on plot

SPECIFIC HEAT OF
DIZINC SILICON TETRAOXIDE
 Zn_2SiO_4

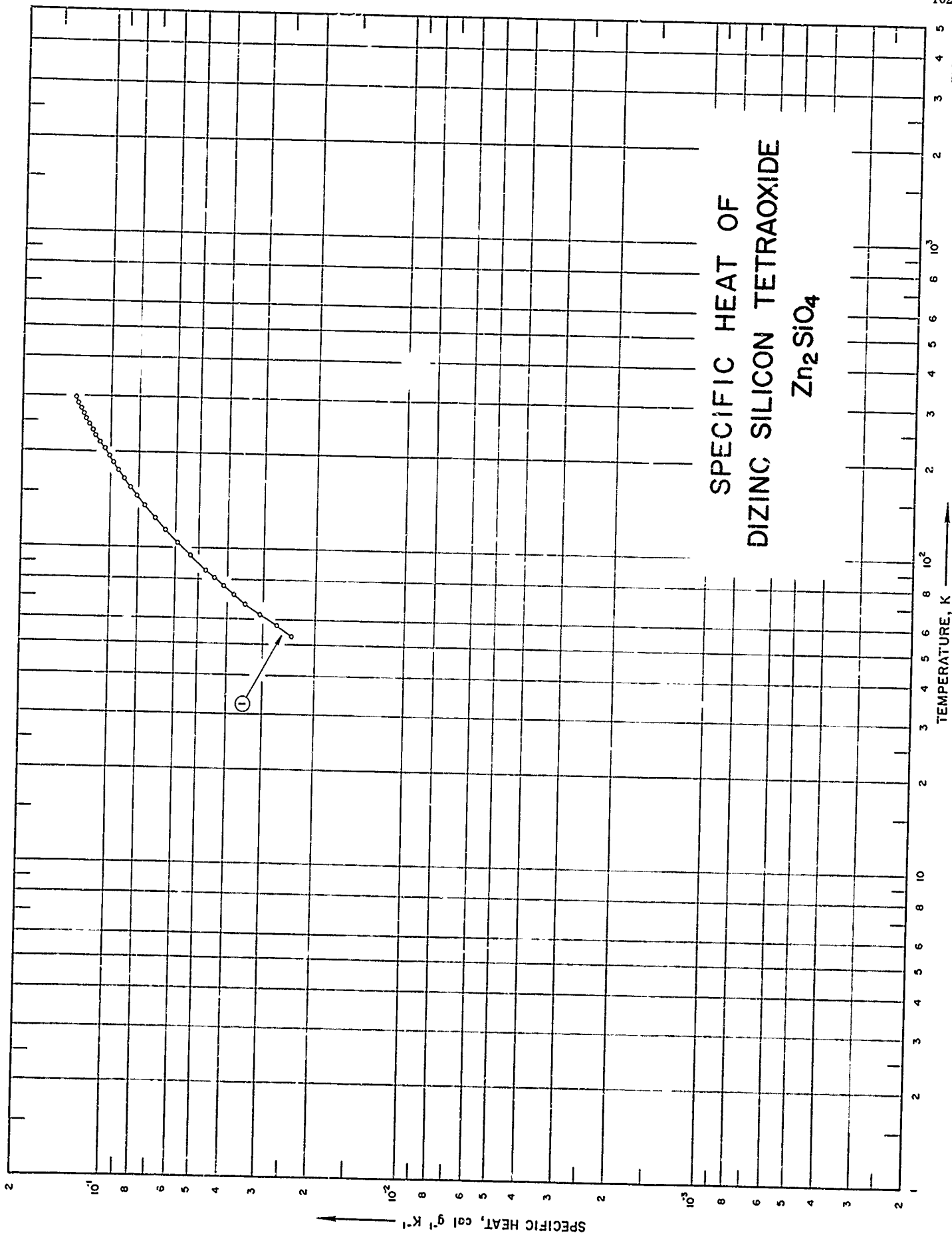

SPECIFICATION TABLE NO. 519 SPECIFIC HEAT OF DIZINC SILICON TETRAOXIDE Zn_2SiO_4

[For Data Reported in Figure and Table No. 519]

Curve No.	Ref. No.	Year	Temp. Range, K	Reported Error, %	Name and Specimen Designation	Composition (weight percent), Specifications and Remarks
1	359	1951	53-298		Willemite	72.95 ZnO, 26.92 SiO ₂ (73.05, 26.95 theo.), remainder impurities probably Fe ₂ O ₃ , Al ₂ O ₃ , and MgO.

DATA TABLE NO. 519 SPECIFIC HEAT OF DIZINC SILICON TETRAOXIDE Zn_2SiO_4
 [Temperature, T, K; Specific Heat, C_p , Cal $g^{-1}K^{-1}$]

T	C_p
<u>CURVE 1</u>	
53.01	2.406×10^{-2}
57.34	2.714
62.00	3.078
66.68	3.441
71.55	3.790
76.37	4.117
80.63	4.417
85.08	4.712
94.71	5.327
104.42	5.902
114.50	6.480
124.69	7.037
136.61	7.621
146.09	8.114
155.90	8.554
165.83	8.994
175.95	9.407
185.88	9.811
195.89	1.018×10^{-1}
206.18	1.054
216.21	1.091
225.86	1.125
236.15	1.156
245.68	1.185
256.06	1.214
266.03	1.244
276.00	1.270
286.51	1.296
296.24	1.318*
298.16	1.321

* Not shown on plot

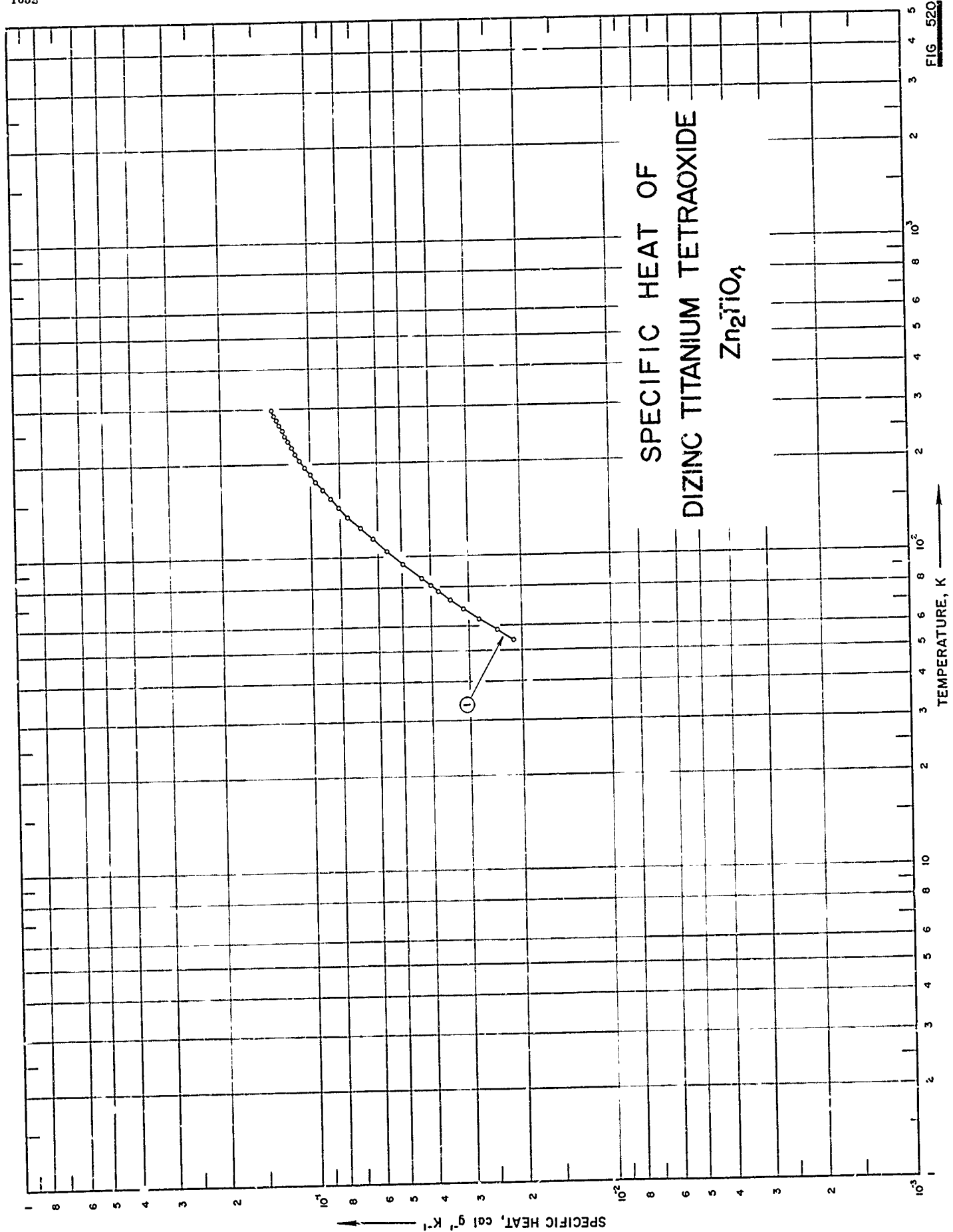

FIG 520

SPECIFICATION TABLE NO. 520 SPECIFIC HEAT OF DIZINC TITANIUM TETRAOXIDE Zn_2TiO_4

[For Data Reported in Figure and Table No. 520]

Curve No.	Ref. No.	Year	Temp. Range, K	Reported Error, %	Name and Specimen Designation	Composition (weight percent), Specifications and Remarks
1	358	1955	54-298			67.08 ZnO, 32.86 TiO (67.07, 32.93 theo.), 0.05 insoluble in HCl; prepared from reagent-grade zinc oxide and pure titania; pressed into pellets; heated 4 times for total of 65 hrs above 1000 C; quenched to room temperature.

DATA TABLE NO. 520 SPECIFIC HEAT OF DIZINC TITANIUM TETRAOXIDE Zn_2TiO_4
 [Temperature, T, K; Specific Heat, C_p , Cal $g^{-1}K^{-1}$]

T	C_p
	CURVE 1
53.88	2.137×10^{-2}
58.15	2.429
62.94	2.781
67.80	3.130
72.68	3.465
77.30	3.780
80.83	4.038
85.11	4.315
94.80	4.974
104.72	5.625
114.28	6.256
124.63	6.894
135.83	7.562
145.47	8.110
155.71	8.650
165.52	9.153
175.98	9.655
185.75	1.009×10^{-1}
195.99	1.051
206.62	1.091
216.08	1.125
226.04	1.161
235.80	1.192
245.68	1.223
256.13	1.250
266.07	1.278
276.25	1.303
286.39	1.327
296.51	1.348*
298.16	1.353

* Not shown on plot

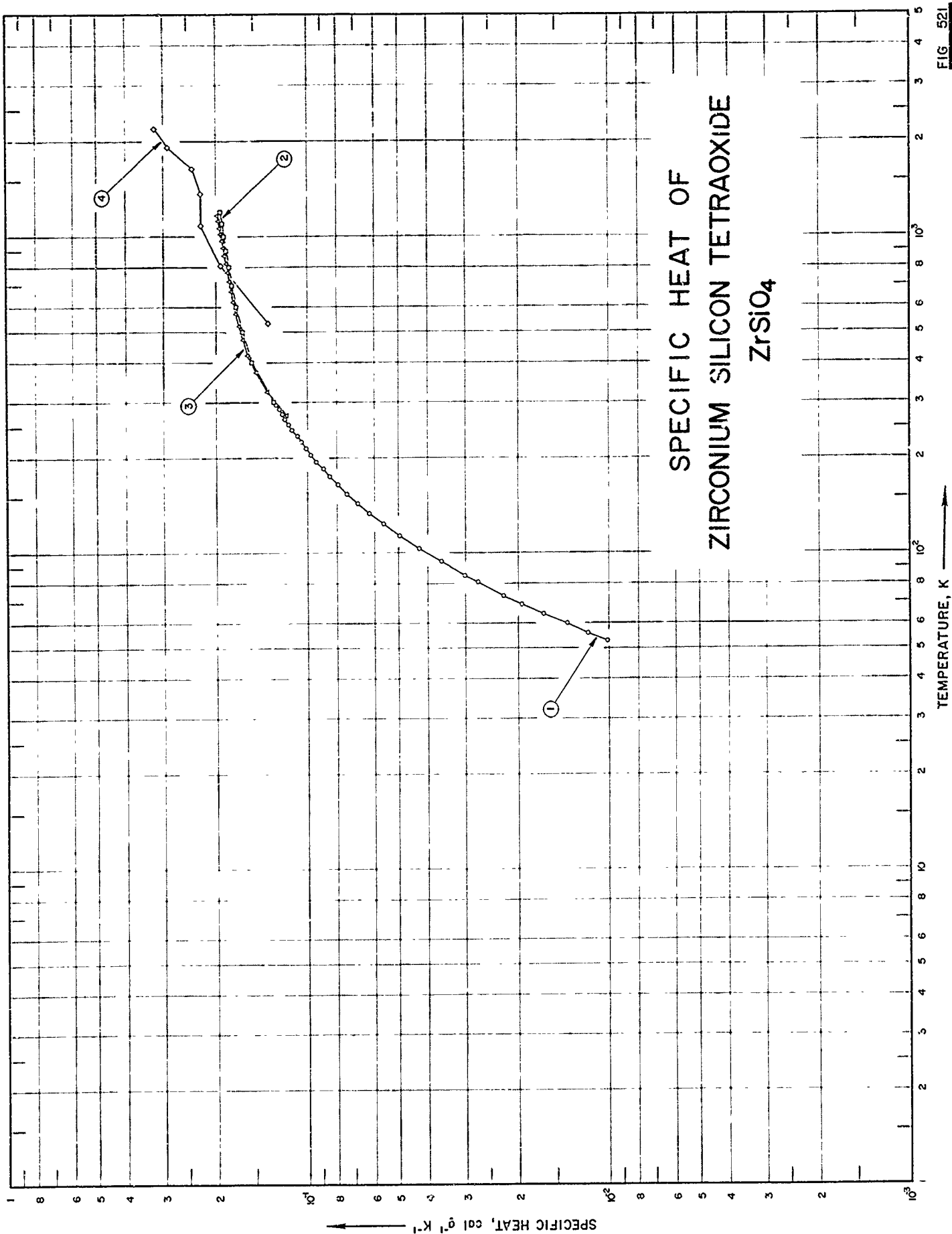

FIG. 521

SPECIFICATION TABLE NO. 521 SPECIFIC HEAT OF ZIRCONIUM SILICON TETRAOXIDE $ZrSiO_4$

[For Data Reported in Figure and Table No. 521]

Curve No.	Ref. No.	Year	Temp. Range, K	Reported Error, %	Name and Specimen Designation	Composition (weight percent), Specifications and Remarks
1	387	1941	53-295			98.6 $ZrSiO_4$, 1.3 SiO_2 , 0.04 Fe_2O_3 ; corrected for Fe_2O_3 and excess SiO_2 .
2	154	1950	298-1800			66.30 ZrO_2 including HfO_2 with 1.15 Hf, 33.6 SiO_2 , 0.4 Fe_2O_3 .
3	94	1960	273-1173	0.25		65.4 ZrO_2 + HfO_2 , 33.2 SiO_2 , 0.1-1 Al, 0.1-1 Ti, 0.01-0.1 Fe, <0.01 Ag, <0.01 Ca, <0.01 Cu, <0.0001 Mn; fired and sintered to form of small cylinders.
4	32	1963	533-2200	±5	Taylor Zircon CZ-5	65-66 ZrO_2 , 33-34 SiO_2 , 1 max Al_2O_3 , 0.3 max TiO_2 , 0.1 max Fe_2O_3 , 0.2 max others; sample supplied by Charles Taylor and Sons Co.; slip-cast and sintered; density = 252 lb ft ⁻³ .

DATA TABLE NO. 521 SPECIFIC HEAT OF ZIRCONIUM SILICON TETRAOXIDE $ZrSiO_4$
 [Temperature, T, K; Specific Heat, C_p , Cal $g^{-1}K^{-1}$]

T	C_p	T	C_p
<u>CURVE 1</u>			
52.7	1.013×10^{-2}	1500	2.02×10^{-1}
55.8	1.177	1600	2.04
59.7	1.384	1700	2.07
64.1	1.654	1800	2.09
68.7	1.949	<u>CURVE 3</u>	
73.3	2.250	273.15	1.178×10^{-1}
80.6	2.728	323.15	1.366
84.9	3.012	373.15	1.488
93.9	3.631	423.15	1.574
103.4	4.275	473.15	1.637
113.9	4.959	523.15	1.687
124.1	5.631	573.15	1.727
134.3	6.258	623.15	1.760
144.8	6.820	673.15	1.789
154.7	7.404	723.15	1.815
165.0	7.982	773.15	1.838
175.2	8.457	823.15	1.859
185.0	8.899	873.15	1.879
195.5	9.368	923.15	1.897
205.6	9.783	973.15	1.915
215.4	1.014×10^{-1}	1023.15	1.931
225.2	1.052	1073.15	1.947
235.7	1.090	1123.15	1.963
245.6	1.127	1173.15	1.978
255.4	1.161	<u>CURVE 4</u>	
265.8	1.192	533.16	1.35×10^{-1}
275.8	1.219	810.94	1.93
285.5	1.244	1088.72	2.25
294.8	1.275	1366.49	2.25
<u>CURVE 2</u>			
298	1.28×10^{-1}	1644.27	2.40
300	1.29	1922.05	2.90
400	1.53	2199.83	3.20
500	1.65		
600	1.72		
700	1.78		
800	1.82		
900	1.86		
1000	1.89		
1100	1.91		
1200	1.94		
1300	1.97		
1400	1.99		

REFERENCES TO DATA SOURCES

- | Ref.
No. | TPRC
No. | |
|-------------|-------------|--|
| 1 | 9820 | Desnoyers, J.E. and Morrison, J.A., <i>Phil. Mag.</i> , <u>3</u> (25), 42-8, 1958. |
| 2 | 23953 | Burk, D.L. and Friedberg, S.A., <i>Phys. Rev.</i> , <u>111</u> (5), 1275-82, 1958. |
| 3 | 27469 | Victor, A.C., <i>J. Am. Chem. Soc.</i> , <u>36</u> , 1903-11, 1962. |
| 4 | 882 | DeSorbo, W., <i>J. Chem. Phys.</i> , <u>21</u> , 876-80, 1953. |
| 5 | 20786 | Rasor, N.S. and McClelland, J.D., <i>J. Phys. Chem. Solids</i> , <u>15</u> , 17-26, 1960. |
| 6 | 26335 | Barriault, R.J., Bender, S.L., Dreikorn, R.E., Einwohner, T.H., Feber, R.C., Gannon, R.E., Hanst, P.L., Ihnat, M.E., Phaneuf, J.P., Schick, H.L., and Ward, C.H., ASD TR 61-260, 1-404, 1962. [AD 278 633] |
| 7 | 37904 | West, E.D. and Ishihara, S., <i>Advances Thermophys. Properties Extrem. Temp. Pres.</i> , 3rd ASME Symp., Lafayette, Indiana. 146-51, 1965. |
| 8 | 28005 | Svikis, V.D., <i>Can. Dept. Mines Tech. Surv., Mines Branch, Res. Rept.</i> R96, 1-42, 1962. |
| 9 | 10947 | Lucks, C.F., Deem, H.W., and Wood, W.D., <i>Am. Ceram. Soc. Bull.</i> , <u>39</u> (6), 313-9, 1960. |
| 10 | 26074 | Neel, D.S., Pears, C.D., and Oglesby, S., Jr., WADD TR 60-924, 1-201, 1962. [AD 275 536] |
| 11 | 16590 | Fieldhouse, I.B., Lang, J.I., and Blau, H.H., WADC TR 59-744 <u>4</u> , 1-78, 1960. [AD 249 166] |
| 12 | 869 | De Sorbo, W., <i>J. Am. Chem. Soc.</i> , <u>77</u> , 4713-5, 1955. |
| 13 | 12245 | De Sorbo, W. and Nichols, G.E., <i>J. Phys. Chem. Solids</i> , <u>6</u> (4), 352-66, 1958. |
| 14 | 23306 | VanderHoeven, B.J.C., Jr. and Keesom, P.H., <i>Phys. Rev.</i> , <u>130</u> (4), 1318-21, 1963. |
| 15 | 32615 | De Sorbo, W. and Tyler, W.W., <i>J. Chem. Phys.</i> , <u>21</u> (10), 1660-3, 1953. |
| 16 | 6560 | Lucks, C.F. and Deem, H.W., WADC TR 55-496, 1-65, 1956. [AD 97 185] |
| 17 | 428 | De Sorbo, W. and Tyler, W.W., <i>J. Chem. Phys.</i> , <u>26</u> (2), 244-7, 1957. |
| 18 | 21864 | Parks, G.S. and Kelley, K.K., <i>J. Phys. Chem.</i> , <u>30</u> , 47-55, 1926. |
| 19 | 22766 | Roth, W.A. and Bertram, W.W., <i>Z. Electrochem.</i> , <u>35</u> , 297-308, 1929. |
| 20 | 1895 | Shomate, C.H. and Naylor, B.F., <i>J. Am. Chem. Soc.</i> , <u>67</u> (1), 72-5, 1945. |
| 21 | 26376 | Ginnings, D.C. and Corruccini, R.J., RP-1797, <i>J. Res. Natl. Bur. Std.</i> , <u>38</u> (6), 593-600, 1947. |
| 22 | 20017 | Kerr, E.C., Johnston, H.L., and Hallet, N.C., <i>J. Am. Chem. Soc.</i> , <u>72</u> , 4740-2, 1950. |
| 23 | 1699 | Ginnings, D.C. and Furukawa, G.T., <i>J. Am. Chem. Soc.</i> , <u>75</u> , 522-7, 1953. |
| 24 | 452 | Furukawa, G.T., Douglas, T.B., McCoskey, R.E., and Ginnings, D.C., <i>J. Res. Natl. Bur. Std.</i> , RP 2964, <u>57</u> , 67-82, 1956. |
| 25 | 28902 | Walker, B.E., Grand, J.A., and Ewing, C.T., WADC TR 54-185, Pt. 3, NRLRD 657, 1-15, 1956. |
| 26 | 18576 | West, E.D. and Ginnings, D.C., <i>J. Res. Natl. Bur. Std.</i> , <u>60</u> , 309-16, 1958. |
| 27 | 7689 | Fieldhouse, I.B., Hedge, J.C., and Lang, J.I., WADC TR 58-274, 1-79, 1958. [AD 206 892], [PB 151 583] |
| 28 | 26504 | Romanovskii, V.A. and Tarasov, V.V., <i>Soviet Phys. -Solid State</i> , <u>2</u> (6), 1170-5, 1960. |
| 29 | 29885 | Wiebelt, J.A., Ph.D. Thesis, Oklahoma State Univ., 1-91, 1960. |
| 30 | 20084 | Schmidt, N.E. and Sokolov, V.A., <i>Russ. J. Inorg. Chem.</i> , <u>5</u> , 797-802, 1960. |
| 31 | 16590 | Fieldhouse, I.B., Lang, J.I., and Blau, H.H., WADC TR 59-744, <u>4</u> , 1-78, 1960. [AD 249 166], [PB 171 390] |
| 32 | 26074 | Neel, D.S., Pears, C.D., and Oglesby, S., Jr., WADD TR 60-924, 1-216, 1962. [AD 275 536] |
| 33 | 21364 | Oetting, F.L., <i>Univ. Microfilms, Mic.</i> 60-5976, 1-74, 1961. |
| 34 | 23817 | Hoch, M. and Johnston, H.L., <i>J. Phys. Chem.</i> , <u>65</u> , 1184-5, 1961. |
| 35 | 26393 | Edwards, J.W. and Kington, G.L., <i>Trans. Faraday Soc. (G.B.)</i> , <u>58</u> , Pt. 7, 1313-22, 1962. |
| 36 | 28756 | Martin, D.L., <i>Can. J. Phys.</i> , <u>40</u> , 1166-73, 1962. |

Ref. No.	TPRC No.	
37	25229	Ewing, C.T., Stone, J.P., Spann, J.R., Kovacina, T.A., and Miller, R.R., NRL-5964, 1-13, 1963. [AD 405 673]
38	29980	Prophet, H. and Stull, D.R., J. Chem. Eng. Data, <u>8</u> (1), 78-81, 1963.
39	25497	Sterett, K.F., Blackburn, D.H., Bestul, A.B., Chang, S.S., and Horman, J., Natl. Bur. Std. J. Res., <u>C69</u> (1), 19-26, 1965.
40	21846	Anderson, C.T., J. Am. Chem. Soc., <u>52</u> , 2712-20, 1930.
41	10350	Anderson, C.T., J. Am. Chem. Soc., <u>57</u> , 429-31, 1935.
42	26388	Lander, J.J., J. Am. Chem. Soc., <u>73</u> , 5794-7, 1951.
43	11861	Kelley, K.K., J. Am. Chem. Soc., <u>61</u> , 1217-8, 1939.
44	15021	Kandyba, V.V., Kantor, P.B., Krasovitskaya, R.M., and Formichev, E.N., AEC-TR-4310, 1-3, 1960.
45	29978	Walker, B.E., Jr., Ewign, C.T., and Miller, R.R., J. Chem. Eng. Data, <u>7</u> , 595-7, 1962.
46	30541	Victor, A.C. and Douglas, T.B., J. Res. Natl. Bur. Std., <u>67A</u> (4), 325-9, 1963.
47	25961	Hedge, J.C., Kostenko, C., and Lang, J.I., ASD-TDR 63-597, 1-128, 1963. [AD 424 375]
48	26008	Pears, C.D., ASD-TDR 62-765, 1-420, 1963. [AD 298 061]
49	21834	Anderson, C.T., J. Am. Chem. Soc., <u>52</u> , 2720-3, 1930.
50	28368	Kelley, K.K., J. Am. Chem. Soc., <u>63</u> , 1137-9, 1941.
51	30685	Southard, J.C., J. Am. Chem. Soc., <u>63</u> , 3147-50, 1941.
52	30663	Kerr, E.C., Hersh, H.N., and Johnston, H.L., J. Am. Chem. Soc., <u>72</u> , 4738-40, 1950.
53	21864	Parks, G.S. and Kelley, K.K., J. Phys. Chem., <u>30</u> , 47-55, 1926.
54	37903	Mezaki, R., Tilleux, E.W., Jambois, T.F., and Margrave, J.L., Advances Thermophys. Properties Extreme Temp. Pres., 3rd ASME Symp., Lafayette, Indiana, 138-45, 1965.
55	31661	Kuznetsov, F.A. and Rezhukhina, T.N., Russ. J. Phys. Chem., <u>34</u> (1i), 1164, 1960.
56	7695	Melonas, J.V., Covington, P.C., and Pears, C.D., WADC TR 58-129, 1-15, 1958. [AD 155 816]
57	29312	King, E.G. and Christensen, A.U., U.S. Bur. Mines, Rept. Invest., RI-5789, 1-5, 1961.
58	31603	Weller, W.W. and King, E.G., U.S. Bur. Mines, Rept. Invest., 6245, 1-6, 1963.
59	31604	Pankratz, L.B. and Kelley, K.K., U.S. Bur. Mines, Rept. Invest., 6248, 1-11, 1963.
60	12111	Anderson, C.T., J. Am. Chem. Soc., <u>59</u> , 488-91, 1937.
61	1871	Kelley, K.K., Boericke, F.S., Moore, G.E., Huffman, E.H., and Bangert, W.M., U.S. Bur. Mines, Tech. Paper, 662, 1-43, 1944.
62	521	Volger, J., Nature (England), <u>170</u> , 1027, 1952.
63	1351	King, E.G., J. Am. Chem. Soc., <u>79</u> , 2333-400, 1957.
64	9764	King, E.G. and Christensen, A.U., Jr., J. Am. Chem. Soc., <u>80</u> , 1800-1, 1958.
65	21814	Millar, R.W., J. Am. Chem. Soc., <u>51</u> , 215-22, 1929.
66	7768	Hu, J.H. and Johnston, H.L., J. Am. Chem. Soc., <u>73</u> , 4550-1, 1951.
67	27444	Gregor, L.V., J. Phys. Chem., <u>66</u> , 1645-7, 1962.
68	7025	Clusius, K. and Harteck, P., Z. Physik. Chem., <u>134</u> , 243-63, 1928.
69	20978	Wohler, L. and Jochum, N., Z. Physik. Chem., <u>167A</u> (3), 169-79, 1933.
70	932	Hu, J.H. and Johnston, H.L., J. Am. Chem. Soc., <u>75</u> , 2471-3, 1953.
71	1213	Assayag, G. and Bizette, H., Compt. Rend. (France), <u>239</u> , 238-40, 1954.
72	27075	Justice, B.H., U.S. At. Energy Comm., TID-12722, 1-175, 1961.
73	26759	Pankratz, L.B., King, E.G., and Kelley, K.K., U.S. Bur. Mines, Rept. Invest., 6033, 1-18, 1962.
74	499	Adams, G.B., Jr. and Johnston, H.L., J. Am. Chem. Soc., <u>74</u> , 4788-9, 1952.
75	18112	King, E.G., J. Am. Chem. Soc., <u>80</u> (8), 1799-1800, 1958.
76	21359	Levinstein, M.A., WADD TR 60-654, 1-91, 1961. [AD 264 223]
77	1295	Todd, S.S. and Bonnickson, K.R., J. Am. Chem. Soc., <u>73</u> , 3894-5, 1951.
78	1296	Coughlin, J.P., King, E.G. and Bonnickson, K.R., J. Am. Chem. Soc., <u>73</u> , 3891-3, 1951.
79	19866	Brown, G.G. and Furnas, C.C., Trans. Am. Inst. Chem. Eng., <u>18</u> , 309-46, 1926.
80	18139	Gronvold, F. and Westrum, E.F., Jr., J. Am. Chem. Soc., <u>81</u> , 1780-3, 1959.
81	1000	Kouvel, J.S., Phys. Rev., <u>102</u> , 1489-90, 1956.

- | Ref. No. | TPRC No. | |
|----------|----------|--|
| 82 | 878 | Blomeke, J.O. and Ziegler, W.T., J. Am. Chem. Soc., <u>73</u> , 5099-5102, 1951. |
| 53 | 10033 | Goldstein, H.W., Neilson, E.F., Walsh, P.N., and White, D., J. Phys. Chem., <u>63</u> , 1445-9, 1959. |
| 84 | 27999 | King, E.G., Weller, W.W., and Pankratz, L.B., U.S. Bur. Mines, Rept. Invest., 5857, 1-6, 1961. |
| 85 | 28374 | Spencer, H.M. and Spicer, W.M., J. Am. Chem. Soc., <u>64</u> , 617-21, 1942. |
| 86 | 9824 | King, E.G., J. Am. Chem. Soc., <u>80</u> , 2400-1, 1958. |
| 87 | 28169 | Kostryukov, V.N. and Morozova, G.K., Russ. J. Phys. Chem., <u>34</u> (8), 873-4, 1960. |
| 88 | 25509 | Rodigina, E.N., Gomel'skii, K.Z., and Luginina, V.F., Zhur. Fiz. Khim., <u>35</u> , 1799-1802, 1961. |
| 89 | 9 | Johnston, H.L. and Bauer, T.W., J. Am. Chem. Soc., <u>73</u> , 1119-22, 1951. |
| 90 | 706 | Shomate, H. and Cohen, A.J., J. Am. Chem. Soc., <u>77</u> , 285-6, 1955. |
| 91 | 12112 | Giauque, W.F. and Archibald, R.C., J. Am. Chem. Soc., <u>59</u> , 561-9, 1937. |
| 92 | 1550 | Arthur, J.S., J. Appl. Phys., <u>21</u> , 732-3, 1950. |
| 93 | 19407 | Barron, T.H.K., Berg, W.T., and Morrison, J.A., Proc. Roy. Soc. (London), <u>A250</u> , 70-83, 1959. |
| 94 | 18701 | Victor, A.C. and Douglas, T.B., WADC TR 57-374, Pl. VI, 1-16, 1960. [AD 258383] |
| 95 | 24812 | Fieldhouse, I.B. and Lang, J.I., WADD TR 60-904, 1-119, 1961. [AD 268304] |
| 96 | 19870 | Lien, W.H., UCRL-9880, 1-78, 1962. |
| 97 | 25901 | Makarounis, O. and Jenkins, R.J., NRDL TR 599, 1-24, 1962. [AD 295887] |
| 98 | 31606 | Pankratz, L.B. and Kelley, K.K., U.S. Bur. Mines, Rept. Invest., 6295, 1-7, 1963. |
| 99 | 21807 | Millar, R.W., J. Am. Chem. Soc., <u>50</u> , 1875-83, 1928. |
| 100 | 28381 | Kelley, K.K. and Moore, G.E., J. Am. Chem. Soc., <u>65</u> , 782-5, 1943. |
| 101 | 23113 | Moore, G.E., J. Am. Chem. Soc., <u>65</u> , 1398-9, 1943. |
| 102 | 30770 | Orr, R.L., J. Am. Chem. Soc., <u>76</u> , 857-8, 1954. |
| 103 | 386 | King, E.G., J. Am. Chem. Soc., <u>76</u> , 3289-91, 1954. |
| 104 | 21830 | Anderson, C.T., J. Am. Chem. Soc., <u>52</u> , 2296-300, 1930. |
| 105 | 534 | Bauer, T.W. and Johnston, H.L., J. Am. Chem. Soc., <u>75</u> , 2217-19, 1953. |
| 106 | 5123 | Seltz, H., Dunkerley, F.J., and DeWitt, B.J., J. Am. Chem. Soc., <u>65</u> , 600-2, 1943. |
| 107 | 2515 | Cosgrove, L.A. and Snyder, P.E., J. Am. Chem. Soc., <u>75</u> , 1227-8, 1953. |
| 108 | 1581 | Smith, D.F., Brown, D., Dworkin, A.S., Sasmor, D.J., and Van Artsdalen, E.R., J. Am. Chem. Soc., <u>78</u> , 1533-6, 1956. |
| 109 | 517 | Westrum, E.F., Jr., Hatcher, J.B., and Osborne, D.W., J. Chem. Phys., <u>21</u> , 419-23, 1953. |
| 110 | 20445 | Seltz, H., DeWitt, B.J., and McDonald, H.J., J. Am. Chem. Soc., <u>62</u> , 88-9, 1940. |
| 111 | 633 | Tomlinson, J.R., Domash, L., Hay, R.G., and Montgomery, C.W., J. Am. Chem. Soc., <u>77</u> , 909-10, 1955. |
| 112 | 25326 | Gel'd, P.V. and Kusenko, F.G., Russ. Met. Fuels, <u>2</u> (2), 43-5, 1960. |
| 113 | 20317 | Kisenko, F.G. and Gel'd, P.V., Izv. Vysshikh Uchebn. Zavedenii. Tsvetn. Met., <u>3</u> (4), 102-6, 1960. |
| 114 | 529 | Orr, R.L., J. Am. Chem. Soc., <u>75</u> , 2808-9, 1953. |
| 115 | 22924 | Sandenaw, T.A., TID 15183, LADC 5260, 1-23, 1962. |
| 116 | 26364 | Sandenaw, T.A., LADC 5555, 1-24, 1963. |
| 117 | 27231 | Gerkin, R.E. and Pitzer, K.S., J. Am. Chem. Soc., <u>84</u> (14), 2662-4, 1962. |
| 118 | 29642 | Nernst, W., Ann. Physik, <u>36</u> (4), 395-439, 1911. |
| 119 | 30241 | Wietzel, R., Z. Anorg. Chem., <u>116</u> , 71-95, 1921. |
| 120 | 26210 | Westrum, E.F., Jr., IV ^o Congress International du Verre, Paris, 396-9, 1956. |
| 121 | 6314 | Moser, H., Physik Z., <u>37</u> (21), 737-53, 1936. |
| 122 | 25447 | Southard, J.C., J. Am. Chem. Soc., <u>63</u> , 3142-6, 1941. |
| 123 | 23932 | Flubacher, P., Leadbetter, A.J., Morrison, J.A., and Stoicheff, B.P., J. Phys. Chem. Solids, <u>12</u> (1), 53-65, 1959. |
| 124 | 26662 | Clark, A.E. and Strakna, R.E., Phys. Chem. Glasses, <u>3</u> (4), 121-6, 1962. |
| 125 | 15366 | Anderson, C.T., J. Am. Chem. Soc., <u>58</u> , 568-70, 1936. |
| 126 | 21319 | Grimley, R.T. and Margrave, J.L., J. Phys. Chem., <u>64</u> , 1763-4, 1960. |
| 127 | 4311 | Kelley, K.K., J. Am. Chem. Soc., <u>62</u> , 818-9, 1940. |

- | Ref. No. | TPRC No. | |
|----------|----------|---|
| 128 | 32377 | Mezaki, R. and Margrave, J. L., J. Phys. Chem., <u>66</u> , 1713-4, 1962. |
| 129 | 7048 | Osborne, D.W. and Westrum, E. F., Jr., ANL 5085, 1-12, 1953. [AD 15 189] |
| 130 | 916 | Osborne, D.W. and Westrum, E. F., Jr., J. Chem. Phys., <u>21</u> , 1884-7, 1953. |
| 131 | 20571 | Victor, A. C. and Douglas, T. B., J. Res. Natl. Bur. Std., <u>65</u> (2), 105-11, 1961. |
| 132 | 21815 | Millar, R. W., J. Am. Chem. Soc., <u>51</u> , 207-14, 1929. |
| 133 | 7830 | Shomate, C. H., J. Am. Chem. Soc., <u>6b</u> , 310-2, 1946. |
| 134 | 5622 | Naylor, B. F., J. Am. Chem. Soc., <u>68</u> , 1077-80, 1946. |
| 135 | 11873 | McDonald, H. J. and Seltz, H., J. Am. Chem. Soc., <u>61</u> , 2405-7, 1939. |
| 136 | 32767 | Shomate, C. H., J. Am. Chem. Soc., <u>69</u> , 218-9, 1947. |
| 137 | 887 | Lietz, J., Hamburger Beitr. Angew. Mineral. Kristallphysik (Germany), <u>1</u> , 229-36, 1956. |
| 138 | 19225 | Keesom, P. H. and Pearlman, N., Phys. Rev., <u>112</u> , 800-4, 1958. |
| 139 | 1741 | Moore, G. E. and Kelley, K. K., J. Am. Chem. Soc., <u>69</u> , 2105-7, 1947. |
| 140 | 28951 | Cabbage, A., Welch, F., and Trice, J. B., NEPA 935-SCR-35 (USAEC), 1-11, 1962. [PB 162 012] |
| 141 | 2109 | Jones, W. M., Gordon, J., and Long, E. A., J. Chem. Phys., <u>20</u> , 695-9, 1952. |
| 142 | 33559 | Long, E. A., Jones, W. M., and Gordon, J., USAEC Rept. A-329, 1-13, 1942. |
| 143 | 20197 | Popov, M. M., Gal'chenko, G. L., and Senin, M. D., Russ. J. Inorgan. Chem., <u>3</u> (8), 18-21, 1958. |
| 144 | 28950 | Powers, H., Welch, F., and Trice, J. B., NEPA 934-SCR-34, (USAEC), 1-16, 1962. [PB 162 011] |
| 145 | 17358 | Westrum, E. F., Jr. and Gronvold, F., J. Am. Chem. Soc., <u>81</u> (8), 1777-80, 1959. |
| 146 | 27564 | Khomysakov, K. G., Spitsyn, V. I., and Zhvanko, S. A., Issled. v Obl. Khim. Urana. Sb. Statei, 141-4, 1961. |
| 147 | 930 | Osborne, D. W., Westrum, E. F., Jr., and Lohr, H. R., J. Am. Chem. Soc., <u>79</u> , 529-30, 1957. |
| 148 | 38590 | Gotoo, K. and Naito, K., J. Phys. Chem. Solids, <u>26</u> (11), 1673-7, 1957. |
| 149 | 23116 | Cook, O. A., J. Am. Chem. Soc., <u>69</u> , 331-3, 1947. |
| 150 | 877 | Jaffray, J. and Lyand, R., Compt. Rend., <u>233</u> , 133-5, 1951. |
| 151 | 15368 | Anderson, C. T., J. Am. Chem. Soc., <u>58</u> , 564-6, 1936. |
| 152 | 21806 | Millar, R. W., J. Am. Chem. Soc., <u>50</u> , 2653-6, 1928. |
| 153 | 4542 | Kelley, K. K., Ind. Eng. Chem., <u>36</u> , 377, 1944. |
| 154 | 1363 | Coughlin, J. P. and King, E. G., J. Am. Chem. Soc., <u>72</u> , 2262-5, 1950. |
| 155 | 15248 | Cutler, M., Snodgrass, H. R., Cheney, G. T., Appel, J., Mallon, C. E., and Meyer, C. H., Jr., USAEC GA-1939, 1-99, 1961. |
| 156 | 32919 | Piesbergen, Von. U., Z. Naturforsch., <u>A18</u> (2), 141-47, 1963. |
| 157 | 33434 | Lundin, C. E., Pool, M. J., and Sullivan, R. W., AF CRL-63-156, DRI No. 2115, 1-55, 1963. [AD 420 015] |
| 158 | 26264 | Kochetkova, N. M. and Rezukhina, T. N., Proc. 4th Semiconductor Materials Conf., Moscow, 26-8, 1961. |
| 159 | 9117 | Nachtrieb, N. H. and Clement, N., J. Phys. Chem., <u>62</u> (7), 876-7, 1958. |
| 160 | 17357 | Gul'tyaev, P. V. and Petrov, A. V., Soviet Phys. -Solid State, <u>1</u> , 330-4, 1959. |
| 161 | 30501 | Wulff, C. A. and Westrum, E. F., Jr., J. Phys. Chem., <u>67</u> (11), 2376-8, 1963. |
| 162 | 24810 | Booker, J., Paine, R. M., and Stonehouse, A. J., WADD TR 60-889, 1-133, 1961. [AD 265 625] |
| 163 | 29086 | Mezaki, R., Tilleux, E. W., Barnes, D. W., and Margrave, J. L., Proc. Intern. Symp. Thermodyn. Nuclear Materials (Vienna), Paper S-M 26/48, 775-88, 1962. |
| 164 | 28935 | Arthur D. Little, Inc. ASD-TDR 62-204, 1-83, 1962. [AD 277 500] |
| 165 | 37348 | Westrum, E. F., Jr. (author), McCluine, L. A. (editor), ASD-TDR-62-204, Pt. III, 1-222 1964. [AD 60.1 424] |
| 166 | 6530 | White, D. and Swift, R. M., 1-37, 1956. [AD 103 561] |
| 167 | 1346 | Swift, R. M. and White, D., J. Am. Chem. Soc., <u>79</u> , 3641-4, 1957. |
| 168 | 30503 | Westrum, E. F., Jr. and Clay, G. A., J. Phys. Chem., <u>67</u> (11), 2385-7, 1963. |
| 169 | 26774 | Kaufman, L. and Clougherty, E. V., RTD-TDR 63-4096, 1-375, 1963. [AD 428 006] |
| 170 | 33446 | Furukawa, G. T., Douglas, T. B., Saba, W. G., and Victor, A. C., Natl. Bur. Std., Rept. No. 8186, 1-178, 1964. [AD 437 168] |

- Ref. TPRC
No. No.
- 171 24224 Kresfovnikov, A.N. and Vendriah, M.S., *Izv. Vysshikh Uchebn. Zavedenii, Tsvet. Met.*, (2), 54-7, 1959.
- 172 36433 Kirillin, V.A., Sheindlin, A.E., Chekhovskoi, V.Ya., and Tyukaev, V.I., *High Temperature*, 2 (5), 640-4, 1964.
- 173 26335 Barriault, R.J., et al., ASD-TR 61-260, 1-404, 1962. [AD 278633]
- 174 33091 Valentine, R.H., Jambois, T.F., and Margrave, J.L., *J. Chem. Eng. Data*, 9 (2), 182-4, 1964.
- 175 6381 Trice, J.B., Neely, J.J., and Teeter, C.E., Jr., AECU-19, NEPA 816, 1-14, 1948.
- 176 9423 Trice, J.B., Neely, J.J., and Teeter, C.E., Jr., USAEC, NEPA 821, 1-9, 1948.
- 177 189 Neely, J.J., Teeter, C.E., Jr., and Trice, J.B., *J. Am. Ceram. Soc.*, 33, 363-4, 1950.
- 178 4298 Kelley, K.K., *Ind. Eng. Chem.*, 33, 1314-15, 1941.
- 179 883 De Sorbo, W., *J. Am. Chem. Soc.*, 75, 1825-7, 1953.
- 180 925 Oriani, R.A. and Murphy, W.K., *J. Am. Chem. Soc.*, 76, 343-5, 1954.
- 181 31301 Seltz, H., McDonald, H.J., and Wells, C., *Am. Inst. Mining Met. Engrs. Tech. Publ.* 1137, 1-11, 1939.
- 182 27756 Swanson, M.L., *Can. J. Phys.*, 40, 719-24, 1962.
- 183 28381 Kelley, K.K. and Moore, C.E., *J. Am. Chem. Soc.*, 65, 782-5, 1943.
- 184 30425 Levinson, L.S., *J. Chem. Phys.*, 42 (9), 3342, 1965.
- 185 29100 Levinstien, M.A., ASD-TDR 62-201, 1-93, 1962. [AD 283967]
- 186 37699 Pankratz, L.B., Weller, W.W., and Kelley, K.K., U.S. Bur. Mines, RI-6446, 1-9, 1964.
- 187 22004 Kruger, O.L. and Savage, H., Argonne Natl. Lab. Annual Rept. 1963, Met. Div., ANL-6868, 133-8, 1963.
- 188 29311 Humprey, G.L., Todd, S.S., Coughlin, J.P., and King, E.G., U.S. Bur. Mines, BM-RI-4888, 1-23, 1952.
- 189 6970 Fieldhouse, I.B., Hedge, J.C., Lang, J.I., and Waterman, T.I., WADC-TR 57-487, 1-78, 1957. [AD 150954] [PB 131718]
- 190 37451 Kirillin, V.A., Sheindlin, A.E., and Chekhovskoi, V.Ya., *High Temperature*, 2 (1), 6-10, 1964.
- 191 36205 Westrum, E.F., Jr., Takahashi, Y., and Stout, N.D., *J. Phys. Chem.*, 69 (5), 1520-4, 1965.
- 192 36207 Takahashi, Y., Westrum, E.F., Jr., and Kent, R.A., *J. Chem. Eng. Data*, 10 (2), 128-9, 1965.
- 193 1877 Kelley, K.K., *Ind. Eng. Chem.*, 36, 865-6, 1944.
- 194 4768 Naylor, B.F., *J. Am. Chem. Soc.*, 68, 370-1, 1946.
- 195 33540 Taylor, R.E. and Nakata, M.M., WADD-TR 60-581, Pt. 4, 1-109, 1963. [AD 428669] [AD 441079]
- 196 36206 Levinson, L.S., *J. Chem. Phys.*, 42 (8), 2891-2, 1965.
- 197 19423 Boettcher, A.B. and Schneider, G., *Proc. U.N. Intern. Conf. Peaceful Uses At. Energy*, 2nd Geneva, 6, 561-3, 1958.
- 198 26961 Mukaibo, T., Naito, K., Sato, K., and Uchijima, T., *Thermodyn. Nucl. Mater. Proc. Symp.*, Vienna, 645-51, 1962.
- 199 29037 Westrum, E.F., Jr., USAEC, TID-16987, 1-15, 1962.
- 200 32764 Harrington, L.C. and Rowe, G.H., TID-4500, PWAC-426, 1-13, 1964.
- 201 37906 Westrum, E.F., Jr., Suits, E., and Lonsdale, H.F., *Advances Thermophys. Properties Extreme Temp. Pres.*, 3rd ASME Symp., Lafayette, Indiana, 156-61, 1965.
- 202 31300 Levinson, L.S., *J. Chem. Phys.*, 38 (9), 2105-6, 1963.
- 203 37907 Farr, J.D., Witteman, W.G., Stone, P.L., and Westrum, E.F., Jr., *Advances Thermophys. Properties Extreme Temp. Pres.*, 3rd ASME Symp., Lafayette, Indiana, 162-6, 1965.
- 204 7462 Shomate, C.H. and Kelley, K.K., *J. Am. Chem. Soc.*, 71, 314-5, 1949.
- 205 6563 King, E.G., *J. Am. Chem. Soc.*, 71, 316-7, 1949.
- 206 24389 Arthur D. Little, Inc., ASD-TDR 62-204, Pt. 2, AF 33-616-7472, 1-125, 1963.
- 207 24203 Kostryukov, V.N., *Russian J. Phys. Chem.*, 35 (8), 865-7, 1961.
- 208 25747 Stalinski, B. and Bieganski, Z., *Bull. Acad. Polon. Sci., Ser. Sci. Chim.*, 8 (5), 243-8, 1960.
- 209 18131 Flowtow, H.E., Lohr, H.R., Abraham, B.M., and Osborne, D.W., *J. Am. Chem. Soc.*, 81, 3529-33, 1959.
- 210 28734 Bieganski, Z. and Stalinski, B., *Bull. Acad. Polon. Sci., Ser. Sci. Chim.*, 9 (5), 367-72, 1961.

Ref. No.	TPRC No.	
211	29939	Flotow, H. E., Osborne, D. W., Otto, K., and Abraham, B. M., J. Chem. Phys., <u>38</u> , 2620-6, 1963.
212	26006	Beck, R. L., ASM Trans., Quart., <u>55</u> (3), 556-64, 1962.
213	27996	Mah, A. D., King, E. G., Weller, W. W., and Christenson, A. U., U. S. Bur. Mines, RI-5716, 1-8, 1961.
214	27512	Gronvold, F. and Westrum, E. F., Jr., Inorg. Chem., <u>1</u> (1), 36-48, 1962.
215	29941	McDonald, R. A. and Stull, D. R., J. Phys. Chem., <u>65</u> , 1918, 1961.
216	29490	Mitchell, D. W., Ind. Eng. Chem., <u>41</u> , 2027-31, 1949.
217	1478	Todd, S. S., J. Am. Chem. Soc., <u>72</u> (7), 2914-5, 1950.
218	29404	Itskevich, E. S., Russ. J. Phys. Chem., <u>35</u> (8), 891-2, 1961.
219	14603	Bolling, G. F., J. Chem. Phys., <u>33</u> (1), 305-6, 1960, Addendum, <u>36</u> (4), 1085-6, 1962.
220	18271	Westrum, E. F., Jr., Chou, C., and Gronvold, F., J. Chem. Phys., <u>30</u> (3), 761-4, 1959.
221	31499	Kelley, K. K., J. Am. Chem. Soc., <u>61</u> , 203-7, 1939.
222	8737	Westrum, E. F., Jr., Chou, C., Machol, R. E., and Gronvold, F., J. Chem. Phys., <u>28</u> (3), 497-503, 1958.
223	24522	Gronvold, F., Thurmann-Moe, T., Westrum, E. F., Jr., and Chang, E., J. Chem. Phys., <u>35</u> (5), 1665-9, 1961.
224	25641	Westrum, E. F., Jr., Carlson, H. G., Gronvold, F., and Kjekshus, A., J. Chem. Phys., <u>35</u> (5), 1670-6, 1961.
225	20836	Harris, P. M., Macwood, G. E., and White, D., WADD-TR 60-771, 1-7C, 1962. [AD 275 508]
226	13174	Gronvold, F. and Westrum, E. F., Jr., Acta Chem. Scand., <u>13</u> , 241-8, 1959.
227	20004	Gronvold, F., Thurmann-Moe, T., Westrum, E. F., Jr., and Levitin, N. E., Acta Chem. Scand., <u>14</u> (3), 634-40, 1960.
228	22207	Baer, Y., Busch, G., Frohlich, C., and Steigmeier, E., Z. Naturforsch (Germany), <u>17A</u> (10), 886-9, 1962.
229	28690	Golutvin, Yu. M., and Liang, C., Russ. J. Phys. Chem., <u>35</u> (1), 62-7, 1961.
230	37449	Kalishевич, G. I., Gel'd, P. V., and Krentsis, R. P., High Temperature, <u>2</u> (1), 11-4, 1964.
231	37419	Dismukes, J. P., Ekstrom, L., Hockings, E. F., Kudman, I., and Lindenbald, N. E., Contr. No. NObs-88595, Proj. Ser-NO-SR 007 1201, Task 802, 1-100, 1964. [AD 441 794]
232	31709	Golutvin, Yu. M., Kozlovskaya, T. M., and Maslennikova, E. G., Russ. J. Phys. Chem., <u>37</u> (6), 723-7, 1963.
233	7088	Douglas, T. B. and Logan, W. M., Natl. Bur. Std., WADC TR 53-201, Pt. 3, 1-13, 1953. [AD 24 019]
234	7132	Ewing, C. T. and Walker, B. E., WADC TR 54-185, 1-27, 1954. [AD 50 565]
235	276	Walker, B. E., Grand, J. A., and Miller, R. R., J. Phys. Chem., <u>60</u> , 231-3, 1956.
236	23764	Golutvin, Yu. M., Russ. J. Phys. Chem., <u>33</u> (8), 164-8, 1959.
237	16770	Snyder, M. J., Duckworth, W. H., BMI-1223, 1-34, 1957. [AD 145 106]
238	31675	Golutvin, Yu. M. and Kozlovskaya, T. M., Russ. J. Phys. Chem., <u>36</u> (2), 183-4, 1962.
239	31602	Pankratz, L. B. and Kelley, K. K., U. S. Bur. Mines Dept., Rept. Invest. No. 6241, 1-5, 1963.
240	1206	Todd, S. S., J. Am. Chem. Soc., <u>75</u> , 1229-31, 1953.
241	18483	Chandrasekharaiah, M. S., Grimley, R. T., and Margrave, J. L., J. Phys. Chem., <u>63</u> , 1505-6, 1959.
242	29243	Topol, L. E. and Ransom, L. D., NAA-SR-6518, 1-2, 1961.
243	956	Clusius, K., Goldmann, J., and Perlick, A., Z. Naturforsch, <u>4A</u> , 424-32, 1949.
244	6647	Cooper, C. B., Univ. of Maryland, Tech. Rept. No. 11, Pt. I, 1-8, 1955. [AD 69 453]
245	6361	Berg, W. T. and Morrison, J. A., Proc. Roy. Soc. (London), <u>242A</u> , 467-92, 1957.
246	37909	Gardner, E. T. and Taylor, A. R., Jr., U. S. Bur. Mines, RI-6435, 1-8, 1964.
247	20196	King, E. G., Weller, W. W., Christensen, A. U., and Kelley, K. K., U. S. Bur. Mines, RI-5799, 1-20, 1961.
248	22239	Itskevich, E. S. and Strelkov, P. G., Russ. J. Phys. Chem., <u>33</u> (7), 60-2, 1959.
249	16023	Topol, L. E. and Ransom, L. D., USAEC, NAN-SR-5111, 1-3, 1960.
250	28384	Kelley, K. K. and Moore, G. E., J. Am. Chem. Soc., <u>65</u> , 1264-7, 1943.
251	19933	Kaylor, C. E., Ph. D. Thesis, Univ. Alabama, Univ. Microfilms Publ. 59-983, 1-103, 1959.

- | Ref. No. | TPRC No. | |
|----------|----------|--|
| 252 | 37911 | Smith, D. F., Kaylor, C. E., Walden, G. E., Taylor, A. R., Jr., and Gayle, J. B., U.S. Bur. Mines, BM-RI-5832, 1-20, 1961. |
| 253 | 29699 | Taylor, A. R., Gardner, T. E., and Smith, D. F., U.S. Bur. Mines, RI-6157, 1-7, 1963. |
| 254 | 16233 | Stout, J. W. and Chisholm, R. C., Inst. Study of Metals, Univ. of Chicago Tech. Rept. 7, 1-50, 1961. [AD 262 535] |
| 255 | 16225 | Chisholm, R. C. and Stout, J. W., Inst. Study of Metals, Univ. of Chicago Tech. Rept. 6, 1-30, 1961. [AD 262 537] |
| 256 | 9968 | Robinson, W. K. and Friedberg, S. A., 1-15, 1959. [AD 219 870] |
| 257 | 647 | Friedberg, S. A., Physica, <u>18</u> , 714-22, 1952. |
| 258 | 23813 | Oetting, F. L. and Gregory, N. W., J. Phys. Chem., <u>65</u> , 138-40, 1961. |
| 259 | 27203 | Friedberg, S. A., Cohen, A. F., and Schelleng, J. H., J. Phys. Soc. (Japan), <u>17</u> , Suppl. B-1, 515-17, 1962. |
| 260 | 26118 | Pfeffer, W., Z. Physik, <u>168</u> (3), 305-15, 1962. |
| 261 | 22945 | Murray, R. B., Phys. Rev., <u>128</u> (4), 1570-4, 1962. |
| 262 | 330 | Friedberg, S. A. and Wasscher, J. D., Physica, <u>19</u> , 1072-8, 1953. |
| 263 | 23918 | Voorhoeve, W. H. M. and Dokoupil, Z., Physica, <u>27</u> (8), 777-82, 1961. |
| 264 | 535 | Busey, R. H. and Glaque, W. F., J. Am. Chem. Soc., <u>74</u> , 4443-6, 1952. |
| 265 | 19850 | Furukawa, G. T., NBS Rept. 6848, 1-17, 1960. [AD 238 686] |
| 266 | 15333 | Southard, J. C. and Nelson, R. A., J. Am. Chem. Soc., <u>55</u> (11), 4865-9, 1933. |
| 267 | 11907 | Keesom, W. H. and Clark, C. W., Physica, <u>2</u> , 698-706, 1935. |
| 268 | 1792 | Mustajoki, A., Ann. Acad. Sci. Fennicae, <u>98</u> , Series A, I, 7-45, 1951. |
| 269 | 469 | Keesom, P. H. and Pearlman, N., Phys. Rev., <u>91</u> , 1354-5, 1953. |
| 270 | 9746 | Strelkov, P. G., Itskevich, E. S., Kostryukov, V. N., and Mirskaya, G. G., Zhur. Fiz. Knim., <u>28</u> , 645-9, 1954. |
| 271 | 1190 | Webb, F. J. and Wilks, J., Proc. Roy. Soc. (London), <u>230A</u> , 549-59, 1955. |
| 272 | 23209 | Yagfarov, M. Sh., Russ. J. Inorg. Chem., <u>6</u> (11), 1236-8, 1961. |
| 273 | 31679 | Kolesov, V. P., Paukov, I. E., and Skuratov, S. M., Russ. J. Phys. Chem., <u>36</u> (4), 400-5, 1962. |
| 274 | 34377 | Bevan, R. B., Jr., Gilbert, R. A., and Busey, R. H., J. Phys. Chem., <u>70</u> (1), 147-50, 1966. |
| 275 | 591 | Cerney, C. and Erdoes, E., Chem. Listy, <u>47</u> , 1742-4, 1953. |
| 276 | 32685 | Smith, D. F., Gardner, T. E., Letson, B. B., and Taylor, A. R., Jr., U.S. Bur. Mines, RI-3616, 1-8, 1963. |
| 277 | 807 | Ginnings, D. C. and Corruccini, R. J., Natl. Bur. Std. U.S. J. Res., <u>39</u> , 309-16, 1947. |
| 278 | 1363 | Coughlin, J. P. and King, E. G., J. Am. Chem. Soc., <u>72</u> , 2262-5, 1950. |
| 279 | 1818 | King, E. G., J. Am. Chem. Soc., <u>79</u> , 2056-7, 1957. |
| 280 | 10354 | Pitzer, K. S., Smith, W. V., and Latimer, W. M., J. Am. Chem. Soc., <u>60</u> , 1826-8, 1938. |
| 281 | 34816 | Taylor, A. R., Jr. and Gardner, T. E., U.S. Bur. Mines, RI 6664, 1-19, 1965. |
| 282 | 1893 | Naylor, B. F., J. Am. Chem. Soc., <u>67</u> , 150-2, 1945. |
| 283 | 955 | Todd, S. S., J. Am. Chem. Soc., <u>71</u> , 4115-6, 1949. |
| 284 | 16843 | King, E. G. and Christensen, A. U., U.S. Bur. Mines, RI-5510, 1-7, 1959. |
| 285 | 24526 | Westrum, E. F., Jr. and Beale, A. F., Jr., J. Phys. Chem., <u>65</u> , 353-5, 1961. |
| 286 | 24586 | Burney, G. A. and Westrum, E. F., Jr., J. Phys. Chem., <u>65</u> , 349-52, 1961. |
| 287 | 903 | Catalano, E. and Stout, J. W., J. Chem. Phys., <u>23</u> , 1803-8, 1955. |
| 288 | 7078 | Douglas, T. B. and Dever, J. L., WADC TR 53-201, Pt. 1, 1-24, 1953. [AD 22 234] |
| 289 | 1704 | Martin, D. L., Phil. Mag., <u>46</u> , 751-8, 1955. |
| 290 | 24585 | Westrum, E. F., Jr. and Burney, G. A., J. Phys. Chem., <u>65</u> , 344-8, 1961. |
| 291 | 28380 | Stout, J. W. and Adams, H. E., J. Am. Chem. Soc., <u>64</u> , 1535-8, 1942. |
| 292 | 10538 | Brady, A. P., Clauss, J. K., and Myers, O. E., WADC TR 56-4, Pt. 1, 1-49, 1957. [AD 131 096] [PB 163 987] |
| 293 | 1304 | Catalano, E. and Stout, J. W., J. Chem. Phys., <u>23</u> (7), 1284-9, 1955. |
| 294 | 30964 | Rao, R. V. G., Das, C. D., Keer, H. V., and Biswas, A. B., Proc. Phys. Soc. (GB), <u>81</u> , Pt. 1 (519), 191-2, 1963. |

- | Ref. No. | TPRC No. | |
|----------|----------|--|
| 295 | 25508 | Pace, E. L. and Mosser, J. S., <i>J. Chem. Phys.</i> , <u>39</u> (1), 154-8, 1963. |
| 296 | 321 | Lohr, H. R., Osborn, D. W., and Westrum, E. F., Jr., <i>J. Am. Chem. Soc.</i> , <u>76</u> , 3837-9, 1954. |
| 297 | 23812 | Euler, R. D. and Westrum, E. F., Jr., <i>J. Phys. Chem.</i> , <u>65</u> , 132-4, 1961. |
| 298 | 1563 | Brickwedde, F. G., Hoge, H. J., and Scott, R. B., <i>J. Chem. Phys.</i> , <u>16</u> (5), 429-36, 1948. |
| 299 | 928 | Osborne, D. W., Westrum, E. F., Jr., and Lohr, H. R., <i>J. Am. Chem. Soc.</i> , <u>77</u> , 2737-9, 1955. |
| 300 | 16878 | Burns, J. H., Osborne, D. W., and Westrum, E. F., Jr., <i>J. Chem. Phys.</i> , <u>33</u> (2), 387-94, 1960. |
| 301 | 5322 | Llewellyn, D. R., <i>J. Am. Chem. Soc.</i> , 28-36, 1953. |
| 302 | 870 | Stout, J. W. and Catalano, E., <i>J. Chem. Phys.</i> , <u>23</u> (11), 2013-22, 1955. |
| 303 | 713 | Dworkin, A. S., Sasmore, D. J., and VanArtsdalen, E. R., <i>J. Am. Chem. Soc.</i> , <u>77</u> , 1304-6, 1955. |
| 304 | 310 | Davies, T. and Staveley, L. A. K., <i>Trans. Faraday Soc.</i> , <u>53</u> , 19-30, 1957. |
| 305 | 17982 | King, E. G. and Weller, W. W., U.S. Bur. Mines, RI-5590, 1-5, 1960. |
| 306 | 17120 | King, E. G. and Weller, W. W., U.S. Bur. Mines, RI-5485, 1-5, 1959. |
| 307 | 18257 | Gronvold, F., Westrum, E. F., Jr., and Chou, C., <i>J. Chem. Phys.</i> , <u>30</u> (2), 528-31, 1959. |
| 308 | 20920 | Eastman, E. D. and Rodebush, W. H., <i>J. Am. Chem. Soc.</i> , <u>40</u> , 489-500, 1918. |
| 309 | 21830 | Anderson, C. T., <i>J. Am. Chem. Soc.</i> , <u>52</u> , 2296-300, 1930. |
| 310 | 31158 | Walker, B. E., Ewing, C. F., and Miller, R. R., <i>J. Phys. Chem.</i> , <u>61</u> , 1682-3, 1957. |
| 311 | 21815 | Millar, R. W., <i>J. Am. Chem. Soc.</i> , <u>51</u> , 207-14, 1929. |
| 312 | 27909 | Itskevich, E. S. and Strelkov, P. G., <i>Russ. J. Phys. Chem.</i> , <u>34</u> (6), 627-9, 1960. |
| 313 | 5948 | Hu, J.-H. and Johnston, H. L., <i>J. Am. Chem. Soc.</i> , <u>74</u> , 4771-2, 1952. |
| 314 | 28986 | O'Neal, H. R., Univ. California, UCRL-10426, 1-66, 1963. |
| 315 | 27995 | Taylor, A. R., Jr. and Smith, D. F., U.S. Bur. Mines, RI-5967, 1-12, 1962. |
| 316 | 39227 | Martin, D. L. and Snowdon, R. L., <i>Can. J. Phys.</i> , <u>44</u> (7), 1449-65, 1966. |
| 317 | 33170 | Goodman, R. M. and Westrum, E. F., Jr., <i>J. Chem. Eng. Data</i> , <u>11</u> (3), 294-5, 1966. |
| 318 | 10352 | Brown, O. L. I., Smith, W. V., and Latimer, W. M., <i>J. Am. Chem. Soc.</i> , <u>58</u> , 1758-9, 1936. |
| 319 | 23983 | Pfeffer, W., <i>Z. Physik</i> , <u>164</u> , 295-302, 1961. |
| 320 | 24314 | Pfeffer, W., <i>Z. Physik</i> , <u>162</u> , 413-20, 1961. |
| 321 | 21222 | Hellwege, K. H., Kuch, F., Niemann, K., and Pfeffer, W., <i>Z. Physik</i> , <u>162</u> , 358-62, 1961. |
| 322 | 23911 | Shirley, D. A., <i>J. Am. Chem. Soc.</i> , <u>82</u> (15), 3841-3, 1960. |
| 323 | 1006 | Kelley, K. K. and Moore, G. E., <i>J. Am. Chem. Soc.</i> , <u>65</u> , 2340-2, 1943. |
| 324 | 25650 | Chisholm, R. C. and Stout, J. W., <i>J. Chem. Phys.</i> , <u>36</u> (4), 972-9, 1962. |
| 325 | 22472 | Popov, M. M., Gal'chenko, G. L., and Senin, M. D., <i>Russ. J. Inorg. Chem.</i> , <u>4</u> (6), 560-2, 1959. |
| 326 | 28398 | Shomate, C. H., <i>J. Am. Chem. Soc.</i> , <u>69</u> , 220-1, 1947. |
| 327 | 26883 | McBride, J. J., Ph. D. Thesis, Univ. Michigan, Univ. Microfilms Publ. 58-950, 1-131, 1958. |
| 328 | 1274 | Voskresenskaya, N. K., Sokolov, V. A., Banashek, E. I., and Schmidt, N. E., <i>Izv. Sektora Fiz. - Khim. Anal. Inst. Obshchei. Neorg. Khim., Akad. Nauk, SSSR</i> , <u>27</u> , 233-8, 1956. |
| 329 | 33921 | Osborne, D. W., Schreiner, F., Malm, J. G., Selig, H., and Rochester, L., <i>J. Chem. Phys.</i> , <u>44</u> (7), 2802-9, 1966. |
| 330 | 39468 | Hornung, E. W., Brodale, G. E., Fisher, R. A., and Giauque, W. F., <i>J. Chem. Phys.</i> , <u>45</u> (2), 614-24, 1966. |
| 331 | 40814 | Hornung, E. W., Fisher, R. A., Brodale, G. E., and Giauque, W. F., <i>J. Chem. Phys.</i> , <u>46</u> (1), 67-72, 1967. |
| 332 | 18220 | Myers, O. E., WADC TR 56-4 (Pt. II), 1-47, 1957. [AD 131 097] |
| 333 | 5095 | Westrum, E. F., Jr. and Pitzer, K. S., <i>J. Am. Chem. Soc.</i> , <u>71</u> , 1940-9, 1949. |
| 334 | 32418 | Johnston, W. V., Pilipovich, D., and Sheenan, D. E., Chicago Univ. Press, 139-43, 1963. |
| 335 | 27248 | McDonald, R. A., Sinko, G. C., and Stull, D. R., <i>J. Chem. Eng. Data</i> , <u>7</u> (1), 83, 1962. |
| 336 | 36294 | Mori, T., Tamura, H., and Sawaguchi, E., <i>J. Phys. Soc. Japan</i> , <u>20</u> (2), 281, 1965. |
| 337 | 20296 | Clayton, R. N. and Marshall, B. J., <i>Phys. Rev.</i> , <u>120</u> , 332-4, 1960. |
| 338 | 27992 | King, E. G. and Weller, W. W., U.S. Bur. Mines, RI-6040, 1-5, 1962. |
| 339 | 37754 | Weller, W. W. and Kelley, K. K., U.S. Bur. Mines, RI-6511, 1-11, 1964. |

- | Ref. No. | TPRC No. | |
|----------|----------|--|
| 340 | 21847 | Anderson, C. T., J. Am. Chem. Soc., <u>53</u> , 476-83, 1931. |
| 341 | 21851 | Anderson, C. T., J. Am. Chem. Soc., <u>54</u> , 107-11, 1932. |
| 342 | 39410 | Huffman, D.R. and Wild, R. L., Phys. Rev., <u>148</u> (2), 526-7, 1966. |
| 343 | 28000 | King, E. G. and Weller, W. W., U.S. Bur. Mines, RI-6001, 1-4, 1962. |
| 344 | 25075 | Corning Materials Handbook, Corning Glass Works Tech. Products Div., 1961. |
| 345 | 307 | Smith, P. L. and Wolcott, N. M., Phil. Mag., <u>1</u> (8), 854-65, 1956. |
| 346 | 21724 | DeVries, T., Ind. Eng. Chem., <u>22</u> , 617-8, 1930. |
| 347 | 901 | Skogan, H. S., Ph. D. Thesis, Rutgers Univ., Univ. Microfilms Publ. 14058, 1-147, 1955. |
| 348 | 24384 | Rudkin, R. L., ASD-TDR-62-24 (Pt. 2), 1-16, 1963. [AD 413 005] |
| 349 | 17360 | Sochava, I. V. and Trapeznikova, O. N., Soviet Phys. Doklady, <u>2</u> , 164-6, 1957. |
| 350 | 15793 | Lockheed Aircraft Corp., Missiles and Space Div., LMSD-288140, 1-28, 1960. [AD 241 410] |
| 351 | 19708 | Booss, H. J., Trans. Met. Soc. AIME, <u>215</u> , 395-7, 1959. |
| 352 | 33351 | Arias, A., Lewis Research Center (Cleveland, Ohio), NASA-TN-D-2464, 1-72, 1964. |
| 353 | 408 | Todd, S. S., J. Am. Chem. Soc., <u>72</u> , 4742-3, 1950. |
| 354 | 32979 | Pankratz, L. B. and Kelley, K. K., U.S. Bur. Mines, RI-6370, 1-7, 1964. |
| 355 | 31605 | Pankratz, L. B., Weller, W. W., and Kelley, K. K., U.S. Bur. Mines, RI-6287, 1-7, 1963. |
| 356 | 26326 | King, E. G. and Weller, W. W., U.S. Bur. Mines, RI-5810, 1-6, 1961. |
| 357 | 30254 | King, E. G., Todd, S. S., and Kelley, K. K., U.S. Bur. Mines, RI-4394, 1-15, 1948. |
| 358 | 362 | King, E. G., J. Am. Chem. Soc., <u>77</u> , 2150-2, 1955. |
| 359 | 28624 | Kelley, K. K., Shomate, C. H., Young, F. E., Naylor, B. F., Salo, A. E., and Huffman, E. H., U.S. Bur. Mines, Tech. Papers 688, 1-104, 1946. |
| 360 | 36238 | Weller, W. W. and Kelley, K. K., U.S. Bur. Mines, RI-6556, 1-8, 1964. |
| 361 | 26614 | Coughlin, J. P. and Orr, R. L., J. Am. Chem. Soc., <u>75</u> (3), 530-1, 1953. |
| 362 | 1793 | Todd, S. S. and Lorenson, R. E., J. Am. Chem. Soc., <u>74</u> , 2043-5, 1952. |
| 363 | 2104 | Todd, S. S. and Lorenson, R. E., J. Am. Chem. Soc., <u>74</u> , 3764-5, 1952. |
| 364 | 17198 | King, E. G. and Weller, W. W., U.S. Bur. Mines, RI-5571, 1-3, 1960. |
| 365 | 672 | King, E. G., J. Phys. Chem., <u>59</u> , 218-9, 1955. |
| 366 | 2132 | King, E. G., Torgeson, D. R., and Cook, O. A., J. Am. Chem. Soc., <u>70</u> , 2160-3, 1948. |
| 367 | 1040 | Bonnicksen, K. R., J. Am. Chem. Soc., <u>76</u> , 1480-2, 1954. |
| 368 | 29697 | Weller, W. W. and King, E. G., U.S. Bur. Mines, RI-6147, 1-6, 1963. |
| 369 | 1297 | Todd, S. S., J. Am. Chem. Soc., <u>73</u> , 3277-8, 1951. |
| 370 | 8941 | King, E. G., J. Am. Chem. Soc., <u>79</u> , 5437-6, 1957. |
| 371 | 29553 | Coughlin, J. P. and O'Brien, C. J., J. Phys. Chem., <u>61</u> , 767-9, 1957. |
| 372 | 21862 | Parks, G. S. and Kelley, K. K., J. Phys. Chem., <u>30</u> , 1175-8, 1926. |
| 373 | 10409 | Cristescu, S. and Simon, F., Z. Physik Chem., <u>B25</u> , 273-82, 1934. |
| 374 | 5624 | Naylor, B. F. and Cook, O. A., J. Am. Chem. Soc., <u>68</u> , 1003-5, 1946. |
| 375 | 23762 | King, E. G. and Weller, W. W., U.S. Bur. Mines, RI-5791, 1-6, 1961. |
| 376 | 28689 | Leonidov, V. Ya., Rezukhina, T. N., and Bereznikova, I. A., Russ. J. Phys. Chem., <u>34</u> (8), 865-6, 1960. |
| 377 | 34594 | Sandenaw, T. A. and Storms, E. K., U.S. At. Energy Comm., LA-331, UC-34, 1-10, 1965. |
| 378 | 29660 | King, E. G. and Weller, W. W., U.S. Bur. Mines, RI-5954, 1-6, 1961. |
| 379 | 32686 | Weller, W. W. and Kelley, K. K., U.S. Bur. Mines, RI-6343, 1-7, 1963. |
| 380 | 26327 | King, E. G. and Weller, W. W., U.S. Bur. Mines, RI-5855, 1-8, 1961. |
| 381 | 30497 | Robie, R. A. and Stout, J. W., J. Phys. Chem., <u>67</u> (11), 2252-6, 1963. |
| 382 | 1579 | King, E. G., J. Phys. Chem., <u>60</u> , 410-2, 1956. |
| 383 | 20869 | Atkins, K. R. and Pollack, S. R., Univ. Pennsylvania, 1-140, 1961. [AD 256 661] |
| 384 | 27471 | Yakovleva, R. A. and Rezukhina, T. N., Russ. J. Phys. Chem., <u>34</u> (4), 390-2, 1960. |
| 385 | 16966 | King, E. G. and Kelley, K. K., U.S. Bur. Mines, RI-5502, 1-6, 1959. |
| 386 | 1868 | Naylor, B. F., Ind. Eng. Chem., <u>26</u> , 333-41, 1944. |

- | Ref. No. | TPRC No. | |
|----------|----------|--|
| 387 | 3791 | Kelley, K.K., J. Am. Chem. Soc., <u>63</u> , 2750-2, 1941. |
| 388 | 26392 | Orr, R. L., J. Am. Chem. Soc., <u>75</u> (3), 528-9, 1953. |
| 389 | 32936 | Weller, W.W. and Kelley, K.K., U.S. Bur. Mines, RI-6357, 1-5, 1964. |
| 390 | 1191 | King, E.G., J. Am. Chem. Soc., <u>77</u> , 3189-90, 1955. |
| 391 | 31672 | Rezukhina, T. N., Levitskii, V. A., and Kazimirova, N.M., Russ. J. Phys. Chem., <u>35</u> (11), 1305-6, 1961. |
| 392 | 1387 | Kelley, K.K., J. Am. Chem. Soc., <u>65</u> , 339-41, 1943. |
| 393 | 26389 | Orr, R. L. and Coughlin, J. P., J. Am. Chem. Soc., <u>74</u> (12) 3186-7, 1952. |
| 394 | 29696 | Weller, W.W. and King, E. G., U.S. Bur. Mines, RI-6130, 1-5, 1962. |
| 395 | 10587 | Grimes, D.M., Westrum, E. F., Jr., and Legvold, S., 1-37, 1957. [AD 135 955] [PB 140 340] |
| 396 | 27914 | Weller, W.W. and King, E. G., U.S. Bur. Mines, RI-6281, 1-4, 1963. |
| 397 | 32980 | Pankratz, L. B., U.S. Bur. Mines, RI-6371, 1-6, 1964. |
| 398 | 17122 | Kelley, K.K., Barany, R., King, E. G., and Chisenon, A. U., U.S. Bur. Mines, RI-5436, 1-16, 1959. |
| 399 | 16773 | Westrum, E. F., Jr., U.S. At. Energy Comm. Rept. No. AECU-3925, 1-27, 1958. |
| 400 | 33605 | Margrave, J. L. and Grimley, R. T., J. Phys. Chem., <u>62</u> , 1436-8, 1958. |
| 401 | 29769 | Weller, W.W. and Kelley, K.K., U.S. Bur. Mines, RI-6191, 1-5, 1963. |
| 402 | 322 | Tarasov, V. V. and Savitskaya, Ya. S., Doklady Akad. Nauk. SSSR, <u>88</u> , 1019-22, 1953. |
| 403 | 1909 | Naylor, B. F., J. Am. Chem. Soc., <u>67</u> , 466-7, 1945. |
| 404 | 2679 | Naylor, B. F., J. Am. Chem. Soc., <u>67</u> , 2120-2, 1945. |
| 405 | 24291 | King, E.G. and Weller, W.W., U.S. Bur. Mines, RI-5715, 1-5, 1961. |
| 406 | 7678 | Westrum, E. F., Jr. and Grimes, D.M., J. Phys. Chem. Solids, <u>6</u> (2), 280-6, 1958. |
| 407 | 33793 | Gerstein, B. C., Chung, P. L., and Danielson, G. C., J. Phys. Chem. Solids, <u>27</u> (6/7), 1161-5, 1966. |
| 408 | 28643 | Clusius, K. and Faber, G., Z. Physik Chem., <u>51B</u> , 352-70, 1942. |
| 409 | 23858 | Saba, W. G., Ph. D. Thesis, Univ. Pittsburgh, Univ. Microfilms Publ. 61-1885, 1-99, 1961. |
| 410 | 27006 | Stalinski, B. and Bieganski, Z., Bull. Akad. Polon. Sci., Ser. Sci. Chim., <u>10</u> , 247-51, 1962. |
| 411 | 25597 | Flotow, H. E., Osborne, D. W., and Otto, K., J. Chem. Phys., <u>36</u> , 866-72, 1962. |
| 412 | 700v | Douglas, T.B. and Victor, A. C., WADC TR57-374, Pt. II, 1-75, 1957. [AD 150 128] |
| 413 | 20428 | Flotow, H. E. and Osborne, D.W., J. Chem. Phys., <u>34</u> (4), 1418-25, 1961. |
| 414 | 21405 | Magnus, A. and Danz, H., Ann. Physik, <u>87</u> , 407-27, 1926. |
| 415 | 39469 | Westrum, E. F., Jr. and Barber, C. M., J. Chem. Phys., <u>45</u> (2), 635-9, 1966. |
| 416 | 25118 | Speidel, E. O. and Keller, D. L., BMI-1633, EURAEC-706, 1-68, 1963. |
| 417 | 39379 | Counsell, J. F., Dell, R. M., and Martin, J. F., Trans. Faraday Soc., <u>62</u> (7), 1736-47, 1966. |
| 418 | 29729 | Kalishevich, G. I., Gel'd, P. V., and Krentsis, R. P., Russ. J. Phys. Chem., <u>39</u> (12), 1602-3, 1965. |
| 419 | 32213 | Krentsis, R. P., Gel'd, P. V., and Kalishevich, G. I., Izv., Vysshikh Uchebn., Zavedenii Chernaya Met., <u>6</u> (9), 161-8, 1963. |
| 420 | 29920 | Krentsis, R. P. and Gel'd, P. V., Izv. Vuz-Chernaya Met., <u>11</u> , 12-41, 1962. |
| 421 | 39630 | Letun, S.M., Gel'd, P. V., and Serebrennikov, N.N., Russ. Metallurgy (Metally), <u>6</u> , 97-103, 1965. |
| 422 | 9116 | King, E.G. and Christensen, A. U., J. Phys. Chem., <u>62</u> (4), 499-500, 1958. |
| 423 | 31318 | Nadzhafov, Yu. B. and Sharifov, K. A., Tr. Inst. Fiz. Akad. Nauk. Azerb. SSR, <u>11</u> , 31-5, 1963. |
| 424 | 29934 | Raub, C. J., Compton, V. B., Geballe, T. H., Matthias, B. T., Maita, J. P., and Hull, G. W., Jr., J. Phys. Chem. Solids, <u>26</u> (12), 2051-7, 1965. |
| 425 | 329 | Dworkin, A. S., Sasmor, D. J., and Van Artsdalen, E. R., J. Chem. Phys., <u>22</u> , 837-42, 1954. |
| 426 | 20619 | Lyubimov, A. P. and Belashchenko, D. K., Sbor. Moskovskogo Inst. Stali., <u>33</u> , 3-11, 1955. |
| 427 | 10348 | Anderson, C. T., J. Am. Chem. Soc., <u>56</u> , 340-2, 1934. |
| 428 | 23287 | Dhar, P. R., Gupta, I. N., and Mahapatra, U. P., Res. and Ind. (New Delhi), <u>6</u> , 6-7, 1961. |
| 429 | 30496 | Stout, J.W. and Robie, R. A., J. Phys. Chem., <u>67</u> (11), 2248-52, 1963. |
| 430 | 31267 | Janz, G. J., Neuenschwander, E., and Kelley, F. J., Trans. Faraday Soc., <u>59</u> , 841-5, 1963. |
| 431 | 12462 | Anderson, C. T., J. Am. Chem. Soc., <u>55</u> , 3621-3, 1933 . |

- | Ref. No. | TPRC No. | |
|----------|----------|--|
| 432 | 10447 | Latimer, W.M. and Ahlberg, J.E., Z. Physik Chem., <u>A148</u> , 464-70, 1930. |
| 433 | 26119 | Hellwege, K.H., Pieffer, W., and Thiel, H.J., Z. Physik, <u>168</u> , 474-7, 1962. |
| 434 | 10353 | Brown, O.L.I. Smith, W.V., and Latimer, W.M., J. Am. Chem. Soc., <u>59</u> 921-4 1937. |
| 435 | 21893 | Thomas, S.B. and Parks, G.S., J. Phys. Chem., <u>35</u> , 2091-102, 1931. |
| 436 | 21850 | Latimer, W.M. and Ahlberg, J.E., J. Am. Chem. Soc., <u>54</u> , 1900-4, 1932. |
| 437 | 10359 | Latimer, W.M., Hicks, J.F.G., Jr., and Shutz, P.W., J. Chem. Phys., <u>1</u> , 620-4, 1933. |
| 438 | 31601 | Taylor, A.R., Jr., Gardner, T.E., and Smith, D.F., U.S. Bur. Mines, RI-6240, 1-8, 1963. |
| 439 | 28623 | Kelley, K.K., Southard, J.C., and Anderson, C.T., U.S. Bur. Mines, Tech. Paper No. 625, 1-73, 1941. |
| 440 | 21809 | Latimer W.M. and Greensfelder, B.S., J. Am. Chem. Soc., <u>50</u> , 2202-13, 1928. |
| 441 | 31012 | Fritz, J.J. and Giaque, W.F., J. Am. Chem. Soc., <u>71</u> , 2168-76, 1949. |
| 442 | 28379 | Long, E.A. and Degraff, R.A., J. Am. Chem. Soc., <u>64</u> , 1346-9, 1942. |
| 443 | 20046 | Lyon, D.N. and Giaque, W.F., J. Am. Chem. Soc., <u>71</u> , 1647-57, 1959. |
| 444 | 27660 | Brackett, T.E., Hornung, E.W., and Hopkins, T.E., J. Am. Chem. Soc., <u>82</u> , 4155-7, 1960. |
| 445 | 27452 | Papadopoulos, M.N. and Giaque, W.F., J. Phys. Chem., <u>66</u> , 2049-50, 1962. |
| 446 | 33432 | Stout, J.W. and Hadley, W.B., Univ. of Chicago, 1-35, 1963. [AD 420 803] |
| 447 | 11848 | Pitzer, K.S. and Coulter, L.V., J. Am. Chem. Soc., <u>60</u> , 1310-3, 1938. |
| 448 | 30698 | Pollitzer, F., Z. Elektrochem., <u>17</u> , 5-14, 1911. |
| 449 | 33489 | Bleaney, B. (Editor), AFCRL-63-192, 1-205, 1963. [AD 411 557] |
| 450 | 11843 | Eastman, E.D. and McGavock, W.C., J. Am. Chem. Soc., <u>59</u> , 145-51, 1937. |
| 451 | 323 | Braune, H. and Möller, O., Z. Naturforsch., <u>9A</u> , 210-7, 1954. |
| 452 | 8410 | West, E.D., J. Am. Chem. Soc., <u>81</u> , 29-37, 1959. |
| 453 | 27515 | Gunther, P., Ann. Physik, <u>51</u> , 828-46, 1916. |
| 454 | 13522 | Carpenter, L.G. and Harle, T.F., Phil. Mag., <u>23</u> , 193-208, 1937. |
| 455 | 11849 | Frederick, K.J. and Hildebrand, J.H., J. Am. Chem. Soc., <u>60</u> , 1437-9, 1938. |
| 456 | 3356 | Young, F.E. and Hildebrand, J.H., J. Am. Chem. Soc., <u>64</u> , 839-40, 1942. |
| 457 | 38605 | Paukov, I.E., Strelkov, P.G., Nograeva, V.V., and Belyi, V.I., Soviet Phys. Doklady, <u>10</u> (5), 460-2, 1965. |
| 458 | 29984 | Westrum, E.F., Jr. and Feick, G., J. Chem. Eng. Data, <u>8</u> , 176-7, 1963. |

Material Index

MATERIAL INDEX TO SPECIFIC HEAT COMPANION VOLUMES 4, 5, AND 6

Material Name	Vol.	Page	Material Name	Vol.	Page
Acetone [(CH ₃) ₂ CO]	6	113	Aluminum silicates:		
Acetylene (CHCH)	6	117	Al ₂ SiO ₅	5	1289
Acetylenogen (see Calcium dicarbide)			Al ₆ Si ₂ O ₁₃	5	1292
Air	6	293	Al ₂ Si ₂ O ₇ ·2H ₂ O	5	1295
AISI 301	4	693	Dialuminum silicon pentaoxide (Al ₂ SiO ₅)	5	1289
AISI 304	4	699	Hexaaluminum disilicon 13-oxide (Al ₆ Si ₂ O ₁₃)	5	1292
AISI 305	4	702	Dialuminum disilicon heptaoxide dihydrate (Al ₂ Si ₂ O ₇ ·2H ₂ O)	5	1295
AISI 310	4	705	Aluminum sulfates:		
AISI 316	4	708	Al ₂ (SO ₄) ₃	5	1161
AISI 347	4	711	Al ₂ (SO ₄) ₃ ·6H ₂ O	5	1164
AISI 420	4	678	Dialuminum trisulfate [Al ₂ (SO ₄) ₃]	5	1161
AISI 430	4	681	Dialuminum trisulfate hexahydrate [Al ₂ (SO ₄) ₃ ·6H ₂ O]	5	1164
AISI 446	4	684	Aluminum titanate (see Dialuminum titanium pentaoxide)		
Alpha brass alloy	4	346	Dialuminum titanium pentaoxide (Al ₂ TiO ₅)	5	1298
Alumel	4	568	Ammonia (NH ₃)	6	61
Alumina (see Aluminum oxide)			Ammonium aluminum sulfates:		
Aluminosilicate glass (SiO ₂ + Al ₂ O ₃ + ΣX _i)	5	1227	NH ₄ Al(SO ₄) ₂	5	1170
Aluminum	4	1	NH ₄ Al(SO ₄) ₂ ·12H ₂ O	5	1173
Aluminum + Copper + ΣX _i	4	511	Ammonium aluminum disulfate [NH ₄ Al(SO ₄) ₂]	5	1170
Aluminum + Zinc + ΣX _i	4	514	Ammonium aluminum disulfate dodecahydrate [NH ₄ Al(SO ₄) ₂ ·12H ₂ O]	5	1173
Aluminum alloys (specific types)			Diammonium sulfate [(NH ₄) ₂ SO ₄]	5	1167
24 S (same as 2024)	4	511	AMS 4901 B (see Titanium, Ti-75 A)		
75 S (same as 7075)	4	514	Antimonic acid anhydride (see Diantimony pentaoxide)		
2024	4	511	Antimony	4	6
7075	4	514	Antimony oxides:		
Aluminum antimonide (AlSb)	5	297	Sb ₂ O ₄	5	39
Aluminum carbide + ΣX _i (Al ₄ C ₃ + ΣX _i)	5	395	Sb ₂ O ₅	5	33
Aluminum trifluoride (AlF ₃)	5	915			
Aluminum nitride (AlN)	5	1075			
Aluminum oxide (Al ₂ O ₃)	5	26			
Aluminum phosphide (AlP)	5	517			

Material Name	Vol.	Page	Material Name	Vol.	Page
			Baking soda (see Sodium bicarbonate)		
Diantimony tetraoxide (Sb ₂ O ₄)	5	30	Barium	4	13
Diantimony pentaoxide (Sb ₂ O ₅)	5	33	Barium carbonate (BaCO ₃)	5	1109
Antimony sulfide (see Diantimony trisulfide)			Barium dichloride (BaCl ₂)	5	785
Diantimony trisulfide (Sb ₂ S ₃)	5	635	Barium dichloride dihydrate (BaCl ₂ ·2H ₂ O)	5	788
Antimony sulfur iodide (SbSI)	5	485	Barium fluoride (see Barium difluoride)		
Argentum (see Silver)			Barium difluoride (BaF ₂)	5	918
Argon	6	1	Barium dinitrate [Ba(NO ₃) ₂]	5	1139
Armco iron	4	102	Barium oxide (BaO)	5	42
Arsenic	4	9	Barium silicates:		
Arsenic acid (see Diarsenic pentaoxide)			BaSiO ₃	5	1301
Arsenic anhydride (see Diarsenic pentaoxide)			Ba ₂ SiO ₄	5	1304
Arsenic triiodide (AsI ₃)	5	488	BaSi ₂ O ₅	5	1307
Arsenic oxides:			Ba ₂ Si ₃ O ₈	5	1310
As ₂ O ₃	5	36	Barium silicon trioxide (BaSiO ₃)	5	1301
As ₂ O ₅	5	39	Dibarium silicon tetraoxide (Ba ₂ SiO ₄)	5	1304
Arsenic sesquioxide (As ₂ O ₃)	5	36	Barium disilicon pentaoxide (BaSi ₂ O ₅)	5	1307
Diarsenic trioxide (see Arsenic sesquioxide)			Dibarium trisilicon octaoxide (Ba ₂ Si ₃ O ₈)	5	1310
Diarsenic pentaoxide (As ₂ O ₅)	5	39	Barium sulfate (BaSO ₄)	5	1176
Arsenic sulfides:			Barium sulfide (BaS)	5	644
AsS	5	638	Barium titanates:		
As ₂ S ₃	5	641	BaTiO ₃	5	1313
Arsenic sulfide (AsS)	5	638	Ba ₂ TiO ₄	5	1316
Arsenic tersulfide (see Diarsenic trisulfide)			Barium titanium trioxide (BaTiO ₃)	5	1313
Diarsenic trisulfide (As ₂ S ₃)	5	641	Dibarium titanium tetraoxide (Ba ₂ TiO ₄)	5	1316
Arsenious acid (see Arsenic sesquioxide)			Barium uranate (see Barium uranium tetraoxide)		
Arsenious iodide (see Arsenic triiodide)			Barium uranium tetraoxide (BaUO ₄)	5	1319
Arsenious oxide (see Arsenic sesquioxide)			Barium zirconate (see Barium zirconium trioxide)		
Arsenious sulfide (see Diarsenic trisulfide)			Barium zirconium trioxide (BaZrO ₃)	5	1322
Arsenous anhydride (see Arsenic sesquioxide)			Benzene (C ₆ H ₆)	6	121
Arsenous sulfide (see Diarsenic trisulfide)			Beryllia (see Beryllium oxide)		
ASTM B 265-58 T, grade 3 and 4 (see Titanium, T1-75A)			Beryllium	4	16
Aurum (see Gold)			Beryllium + Beryllium oxide, cermet (Be + BeO)	5	1243
Austenite (see steel, austenite)					

Material Name	Vol.	Page	Material Name	Vol.	Page
Beryllium aluminate (see Beryllium dialuminum tetraoxide)			Boron carbide (see Tetraboron carbide)		
Beryllium dialuminum tetraoxide (BeAl_2O_4)	5	1325	Tetraboron carbide (B_4C)	5	402
Diberyllium carbide + ΣX_1 ($\text{Be}_2\text{C} + \Sigma X_1$)	5	399	Boron trifluoride (BF_3)	6	67
Beryllium cermet (specific types)			Boron nitride (BN)	5	1078
QMV	5	1243	Boron nitride + Diboron trioxide + ΣX_1 , cermet ($\text{BN} + \text{B}_2\text{O}_3 + \Sigma X_1$)	5	1270
YB 9052	5	1243	Boron nitride + Carbon, cermet (BN + C)	5	1273
YB 9054	5	1243	Boron sesquioxide (B_2O_3)	5	51
Beryllium difluoride (BeF_2)	5	921	Diboron trioxide (see Boron sesquioxide)		
Beryllium oxide (BeO)	5	45	Borosilicate glass ($\text{SiO}_2 + \text{B}_2\text{O}_3 + \Sigma X_1$)	5	1230
Beryllium oxide + Beryllium, cermet ($\text{BeO} + \text{Be}$)	5	1246	Brass	4	346
Beryllium oxide + Beryllium + Molybdenum, cermet ($\text{BeO} + \text{Be} + \text{Mo}$)	5	1249	Brimstone (see Sulfur)		
Beryllium oxide + Molybdenum, cermet ($\text{BeO} + \text{Mo}$)	5	1252	Bromine	6	7
Beryllium oxide + Molybdenum dodecaberlyllide, cermet ($\text{BeO} + \text{MoBe}_{12}$)	5	1255	i-Butane ($\text{i-C}_4\text{H}_{10}$)	6	129
Beryllium oxide + Niobium dodecaberlyllide, cermet ($\text{BeO} + \text{NbBe}_{12}$)	5	1258	n-Butane ($\text{n-C}_4\text{H}_{10}$)	6	136
Beryllium oxide + Tantalum dodecaberlyllide, cermet ($\text{BeO} + \text{TaBe}_{12}$)	5	1261	Butter of zinc (see Zinc dichloride)		
Beryllium oxide + Titanium dodecaberlyllide, cermet ($\text{BeO} + \text{TiBe}_{12}$)	5	1264	Cadmium	4	29
Beryllium oxide + Zirconium 13-berlyllide, cermet ($\text{BeO} + \text{ZrBe}_{13}$)	5	1267	Cadmium + Magnesium (MgCd)	4	294
Diberyllium silicon tetraoxide (Be_2SiO_4)	5	1329	Cadmium + Magnesium (Mg_3Cd)	4	297
Beryllium sulfate (BeSO_4)	5	1179	Cadmium + Magnesium (MgCd_3)	4	300
Bimethyl (see Ethane)			Cadmium dibromide (CdBr_2)	5	759
Bismuth	4	21	Cadmium dichloride (CdCl_2)	5	791
Bismuth + Lead	4	291	Cadmium diiodide (see Cadmium diiodide)		
Bismuth glance (see Dibismuth tritelluride)			Cadmium diiodide (CdI_2)	5	491
Bismuth sesquioxide (Bi_2O_3)	5	48	Cadmium oxide (CdO)	5	54
Dibismuth trioxide (see Bismuth sesquioxide)			Cadmium sulfide (CdS)	5	650
Dibismuth trisulfide (Bi_2S_3)	5	647	Cadmium telluride (CdTe)	5	720
Dibismuth tritelluride (Bi_2Te_3)	5	717	Calcia (see Calcium oxide)		
Bitter spar (see Calcium magnesium dicarbonate)			Calcium	4	32
Boralloy (see Boron nitride)			Calcium aluminates:		
Boron	4	25	CaAl_2O_4	5	1332
	5	1	CaAl_4O_7	5	1335
			$\text{Ca}_3\text{Al}_2\text{O}_6$	5	1338
			$\text{Ca}_{12}\text{Al}_{14}\text{O}_{33}$	5	1341
			Calcium dialuminum tetraoxide (CaAl_2O_4)	5	1332

Material Name	Vol.	Page	Material Name	Vol.	Page
Calcium tetraaluminum heptaoxide (CaAl ₄ O ₇)	5	1335	Calcium fluoride (see Calcium difluoride)		
Tricalcium dialuminum hexaoxide (Ca ₃ Al ₂ O ₆)	5	1338	Calcium difluoride (CaF ₂)	5	924
Dodecacalcium 14-aluminum 33-oxide (Ca ₁₂ Al ₁₄ O ₃₃)	5	1341	Calcium diiron tetraoxide (CaFe ₂ O ₄)	5	1356
Calcium aluminum silicates:			Dicalcium diiron pentaoxide (Ca ₂ Fe ₂ O ₅)	5	1359
CaAl ₂ Si ₂ O ₈	5	1404	Calcium magnesium dicarbonate [CaMg(CO ₃) ₂]	5	1115
Ca ₂ Al ₂ SiO ₇	5	1401	Calcium magnesium silicates:		
CaAl ₂ Si ₂ O ₈ ·2H ₂ O	5	1407	CaMgSi ₂ O ₆	5	1413
Ca ₂ Al ₄ Si ₈ O ₂₄ ·7H ₂ O	5	1410	Ca ₂ MgSi ₂ O ₇	5	1416
Calcium dialuminum disilicon octaoxide (CaAl ₂ Si ₂ O ₈)	5	1404	Ca ₃ MgSi ₂ O ₈	5	1419
Dicalcium dialuminum silicon heptaoxide (Ca ₂ Al ₂ SiO ₇)	5	1401	Ca ₂ Mg ₅ Si ₈ O ₂₃ ·H ₂ O	5	1422
Calcium dialuminum disilicon octaoxide dihydrate (CaAl ₂ Si ₂ O ₈ ·2H ₂ O)	5	1407	Calcium magnesium disilicon hexaoxide (CaMgSi ₂ O ₆)	5	1413
Dicalcium tetraaluminum octasilicon 24-oxide heptahydrate (Ca ₂ Al ₄ Si ₈ O ₂₄ ·7H ₂ O)	5	1410	Dicalcium magnesium disilicon heptaoxide (Ca ₂ MgSi ₂ O ₇)	5	1416
Calcium borates:			Tricalcium magnesium disilicon octaoxide (Ca ₃ MgSi ₂ O ₈)	5	1419
CaB ₂ O ₄	5	1344	Dicalcium pentamagnesium octasilicon 23- oxide monohydrate (Ca ₂ Mg ₅ Si ₈ O ₂₃ ·H ₂ O)	5	1422
CaB ₄ O ₇	5	1347	Calcium molybdate (see Calcium molybde- num tetraoxide)	5	1362
Ca ₂ B ₂ O ₅	5	1350	Calcium molybdenum tetraoxide (CaMoO ₄)	5	1362
Ca ₃ B ₂ O ₆	5	1353	Calcium oxide (CaO)	5	57
Calcium metaborate (see Calcium diboron tetraoxide)			Calcium silicates:		
Monocalcium borate (see Calcium diboron tetraoxide)			CaSiO ₃	5	1365
Calcium diboron tetraoxide (CaB ₂ O ₄)	5	1344	Ca ₂ SiO ₄	5	1368
Calcium tetraboron heptaoxide (CaB ₄ O ₇)	5	1347	Ca ₃ SiO ₅	5	1371
Dicalcium diboron pentaoxide (Ca ₂ B ₂ O ₅)	5	1350	Ca ₃ Si ₂ O ₇	5	1374
Tricalcium diboron hexaoxide (Ca ₃ B ₂ O ₆)	5	1353	Calcium metasilicate (see Calcium silicon trioxide)		
Calcium dicarbide (CaC ₂)	5	405	Calcium orthosilicate (see Dicalcium silicon tetraoxide)		
Calcium carbonate (CaCO ₃)	5	1112	Calcium silicon trioxide (CaSiO ₃)	5	1365
Calcium dichloride (CaCl ₂)	5	794	Dicalcium silicon tetraoxide (Ca ₂ SiO ₄)	5	1368
Calcium ferrites:			Tricalcium silicon pentaoxide (Ca ₃ SiO ₅)	5	1371
CaFe ₂ O ₄	5	1356	Tricalcium disilicon heptaoxide (Ca ₃ Si ₂ O ₇)	5	1374
Ca ₂ Fe ₂ O ₅	5	1359	Calcium sulfates:		
Calcium metaferrite (see Calcium diiron tetraoxide)			CaSO ₄	5	1182
Calcium orthoferrite (see Dicalcium diiron pentaoxide)			CaSO ₄ ·1/2H ₂ O	5	1185

Material Name	Vol.	Page	Material Name	Vol.	Page
Calcium sulfates - continued			Carbon dioxide (CO ₂)	6	143
CaSO ₄ ·2H ₂ O	5	1138	Carbon steel (Group I)	4	619
Calcium sulfate (CaSO ₄)	5	1182	Carbon steel (Group II)	4	623
Calcium sulfate hemihydrate (CaSO ₄ ·1/2H ₂ O)	5	1185	Carbon steel (Group II), eutectoid	4	623
Calcium sulfate dihydrate (CaSO ₄ ·2H ₂ O)	5	1188	Carbon steel (Group II), hyper eutectoid	4	623
Calcium sulfide (CaS)	5	653	Carbon steel (Group II), U-8	4	623
Calcium titanates:			Cassiopeium (see Lutetium)		
CaTiO ₃	5	1377	Celtium (see Hafnium)		
Ca ₃ Ti ₂ O ₇	5	1380	Cerium	4	36
Calcium titanium trioxide (CaTiO ₃)	5	1377	Cerium trifluoride (CeF ₃)	5	927
Tricalcium ditanium heptaoxide (Ca ₃ Ti ₂ O ₇)	5	1380	Cerium oxides:		
Calcium tungstate (see Calcium tungsten tetraoxide)			CeO	5	60
Calcium tungsten tetraoxide (CaWO ₄)	5	1383	Ce ₂ O ₃	5	64
Calcium uranate (see Calcium uranium tetraoxide)			Cerium dioxide (CeO ₂)	5	60
Calcium uranium tetraoxide (CaUO ₄)	5	1386	Cerium sesquioxide (Ce ₂ O ₃)	5	64
Calcium vanadates:			Dicerium trioxide (see Cerium sesquioxide)		
CaV ₂ O ₆	5	1389	Cerium sulfides:		
Ca ₂ V ₂ O ₇	5	1392	CeS	5	656
Ca ₃ V ₂ O ₈	5	1395	Ce ₂ S ₃	5	659
Calcium divanadium hexaoxide (CaV ₂ O ₆)	5	1389	Cerium sulfide (CeS)	5	656
Dicalcium divanadium heptaoxide (Ca ₂ V ₂ O ₇)	5	1392	Dicerium trisulfide (Ce ₂ S ₃)	5	659
Tricalcium divanadium octaoxide (Ca ₃ V ₂ O ₈)	5	1395	Cermets:		
Calcium wolframite (see Calcium tungsten tetraoxide)			Be + BeO	5	1243
Calcium zirconate (see Calcium zirconium trioxide)			BeO + Be	5	1246
Calcium zirconium trioxide (CaZrO ₃)	5	1398	BeO + Be + Mo	5	1249
Carbon, diamond	5	4	BeO + Mo	5	1252
Carbon, graphite	5	9	BeO + MoBe ₁₂	5	1255
Carbon + Silicon carbide, cermet (C + SiC)	5	1276	BeO + NbBe ₁₂	5	1258
Carbon tetrachloride (CCl ₄)	6	159	BeO + TaBe ₁₂	5	1261
Carbon oxides:			BeO + TiBe ₁₂	5	1264
CO	6	152	BeO + ZrBe ₁₃	5	1267
CO ₂	6	143	BN + B ₂ O ₃ + ΣX _i	5	1270
Carbon monoxide (CO)	6	152	BN + C	5	1273
			C + SiC	5	1276
			SiC + C + ΣX _i	5	1279

Material Name	Vol.	Page	Material Name	Vol.	Page
Cermets - continued			Trichromium dicarbide (Cr ₃ C ₂)	5	408
WC + CO	5	1282	Tetrachromium carbide (Cr ₄ C)	5	414
ZrO ₂ + Ti	5	1285	Pentachromium dicarbide (Cr ₅ C ₂)	5	411
Cesium	4	40	Heptachromium tricarbide (Cr ₇ C ₃)	5	417
Cesium aluminum disulfate dodecahydrate [CsAl(SO ₄) ₂ · 12H ₂ O]	5	1191	Chromium chlorides:		
Cesium chloride (CsCl)	5	797	CrCl ₂	5	800
Cesium monohydrogen difluoride (CsHF ₂)	5	931	CrCl ₃	5	803
Cesium iodide (CsI)	5	494	Chromium dichloride (CrCl ₂)	5	800
Chlorine	6	11	Chromium trichloride (CrCl ₃)	5	803
Chlorodifluoromethane (see Freon 22)			Chromium sesquioxide (Cr ₂ O ₃)	5	67
Chlorotrifluoromethane (see Freon 13)			Dichromium trioxide (see Chromium sesquioxide)		
Chloroform (CHCl ₃)	6	166	Chromium silicides:		
Chloromethane (see Methyl chloride)			CrSi	5	565
Chromel A (see Nichrome V)			CrSi ₂	5	568
Chromel P	4	392	Cr ₃ Si	5	559
Chromium	4	44	Cr ₅ Si ₃	5	562
Chromium + Aluminum	4	304	Chromium silicide (CrSi)	5	565
Chromium + Aluminum + ΣX _i	4	517	Chromium disilicide (CrSi ₂)	5	568
Chromium + Iron	4	307	Trichromium silicide (Cr ₃ Si)	5	559
Chromium + Iron + ΣX _i	4	520	Pentachromium trisilicide (Cr ₅ Si ₃)	5	562
Chromium + Manganese	4	311	Cobalt	4	48
Chromium alloys (specific types)			Cobalt + Chromium + ΣX _i	4	523, 526
Aluminothermic chromium	4	520	Cobalt + Dysprosium (DyCo ₅)	4	314
Ferrochromium	4	520	Cobalt + Iron	4	317
Chromium borides:			Cobalt + Nickel	4	320
CrB	5	335	Cobalt alloy, HE 1049	4	526
CrB ₂	5	338	Cobalt chlorides:		
Chromium monoboride (CrB)	5	335	CoCl ₂	5	806
Chromium diboride (CrB ₂)	5	338	CoCl ₂ · 6H ₂ O	5	809
Chromium carbides:			Cobalt dichloride (CoCl ₂)	5	806
Cr ₃ C ₂	5	408	Cobalt dichloride hexahydrate (CoCl ₂ · 6H ₂ O)	5	809
Cr ₄ C	5	414	Cobalt ferrites:		
Cr ₅ C ₂	5	411	CoFe ₂ O ₄	5	1425
Cr ₇ C ₃	5	417	Co _x Fe ₃ O ₄ (nonstoichiometric)	5	1428

Material Name	Vol.	Page	Material Name	Vol.	Page
Cobalt diiron tetraoxide (CoFe ₂ O ₄)	5	1425	Copper alloys (specific types)		
Cobalt iron tetraoxide, nonstoichiometric (Co _x Fe _y O ₄)	5	1428	Manganin	4	338
Cobalt difluoride (CoF ₂)	5	934	Monel	4	562
Cobalt oxides:			Copper bromide (CuBr)	5	762
CoO	5	70	Copper chlorides:		
Co ₃ O ₄	5	73	CuCl ₂	5	812
Cobalt monoxide (CoO)	5	70	CuCl ₂ ·2H ₂ O	5	815
Tricobalt tetraoxide (Co ₃ O ₄)	5	73	Copper dichloride (CuCl ₂)	5	812
Cobalto-cobaltic oxide (see Tricobalt tetraoxide)			Copper dichloride dihydrate (CuCl ₂ ·2H ₂ O)	5	815
Cobaltosic oxide (see Tricobalt tetraoxide)			Copper ferrites:		
Cobaltouscobaltic oxide (see Tricobalt tetraoxide)			CuFe ₂ O ₄	5	1437
Cobalt silicide (CoSi)	5	571	Cu _x Fe _y O ₄ (nonstoichiometric)	5	1434
Cobalt sulfate heptahydrate (CoSO ₄ ·7H ₂ O)	5	1194	Copper diiron tetraoxide (CuFe ₂ O ₄)	5	1437
Cobalt tungstate (see Cobalt tungsten tetraoxide)			Copper iron tetraoxide, nonstoichiometric (Cu _x Fe _y O ₄)	5	1434
Cobalt tungsten tetraoxide (CoWO ₄)	5	1431	Copper hemioxide (see Copperous oxide)		
Columbium (see Niobium)			Dicopper monoxide (see Copperous oxide)		
Constantan	4	341	Copper oxides:		
Copper	4	51	CuO	5	80
Copper, electrolytic	4	51	Cu ₂ O	5	76
Copper, electrolytic tough pitch (Fed. Spec. QQC-502)	4	51	Copperas (see Iron sulfate heptahydrate)		
Copper, electrolytic tough pitch (Fed. Spec. QQC-576)	4	51	Copperic oxide (CuO)	5	80
Copper, OFHC	4	51	Copperous oxide (Cu ₂ O)	5	76
Copper + Aluminum	4	323	Copper protoxide (see Copperous oxide)		
Copper + Chromium + Ni	4	526	Copper suboxide (see Copperous oxide)		
Copper + Gallium	4	327	Copper sulfides:		
Copper + Iron	4	331	CuS	5	662
Copper + Magnesium	4	335	Cu ₂ S	5	665
Copper + Magnesium + Aluminum (MgCu _{2-x} Al _x)	4	529	Copper sulfide (CuS)	5	662
Copper + Magnesium + Silicon (MgCu _{2-x} Si _x)	4	532	Dicopper sulfide (Cu ₂ S)	5	665
Copper + Manganese	4	338	Cordierite (see Dimagnesium tetraaluminum pentasilicon 18-oxide)		
Copper + Nickel	4	341	Corning 1723 glass	5	1227
Copper + Zinc	4	346	Corundum (see Aluminum oxide)		
			Crucible HMM HNM	4	714
			Cuprum (see Copper)		

Material Name	Vol.	Page	Material Name	Vol.	Page
n-Decane (C ₁₀ H ₂₂)	6	170	Ethylene alcohol (see Ethylene glycol)		
Deuterium	6	15	Ethylene glycol (CH ₂ OHCH ₂ OH)	6	192
Diamond (see Carbon, diamond)			Ethyne (see Acetylene)		
Dichlorodifluoromethane (see Freon 12)			Europium	4	68
Dichlorofluoromethane (see Freon 21)			Europium oxide (Eu ₂ O ₃)	5	89
1,2-Dichloro-1,1,2,2-tetrafluoroethane (see Freon 114)			Dieuropium trisulfate octahydrate (Eu ₂ (SO ₄) ₃ · 8H ₂ O)	5	1197
Dimethyl (see Ethane)			Ferric oxide [see Iron (ic) oxide]		
Dimethyl ketone (see Acetone)			Ferroniobium	4	574
Dimethylmethane (see Propane)			Ferrous chloride (see Iron dichloride)		
Dysprosia (see Dysprosium oxide)			Ferrous ferric oxide (see Triiron tetraoxide)		
Dysprosium	4	62	Ferrous fluoride (see Iron difluoride)		
Dysprosium trichloride hexahydrate (DyCl ₃ ·6H ₂ O)	5	818	Ferrous oxide [see Iron (ous) oxide]		
Dysprosium oxide (Dy ₂ O ₃)	5	83	Ferrum (see Iron)		
Dysprosium sesquioxide (see Dysprosium oxide)			Flowers of tin (see Tin dioxide)		
Didysprosium trioxide (see Dysprosium oxide)			Fluorine	6	19
Erbia (see Erbium oxide)			Freon 10 (see Carbon tetrachloride)		
Erbium	4	65	Freon 11 (Cl ₃ CF)	6	200
Erbium trichloride hexahydrate (ErCl ₃ ·6H ₂ O)	5	822	Freon 12 (Cl ₂ CF ₂)	6	204
Erbium gallate (see Trierbium pentagallium dodecaoxide)			Freon 13 (ClCF ₃)	6	210
Trierbium pentagallium dodecaoxide { Er ₃ Ga ₅ O ₁₂ (Garnet) }	5	1440	Freon 20 (see Chloroform)		
Erbium oxide (Er ₂ O ₃)	5	96	Freon 21 (Cl ₂ CHF)	6	212
Erbium sesquioxide (see Erbium oxide)			Freon 22 (ClCHF ₂)	6	218
Erbium trioxide (see Erbium oxide)			Freon 113 (CCl ₂ FCClF ₂)	6	224
Ethane (C ₂ H ₆)	6	174	Freon 114 (CClF ₂ CClF ₂)	6	228
1,2-Ethanediol (see Ethylene glycol)			Gadolinia (see Gadolinium oxide)		
Ethene (see Ethylene)			Gadolinium	4	72
Ethyne (see Acetylene)			Gadolinium trichloride hexahydrate (GdCl ₃ ·6H ₂ O)	5	826
Ethoxyethane (see Ethyl ether)			Gadolinium trinitrate hexahydrate (Gd(NO ₃) ₃ ·6H ₂ O)	5	1142
Ethyl Alcohol (C ₂ H ₅ OH)	6	180	Gadolinium oxide (Gd ₂ O ₃)	5	92
Ethyl ether [(C ₂ H ₅) ₂ O]	6	194	Gadolinium sesquioxide (see Gadolinium oxide)		
Ethyl oxide (see Ethyl ether)			Digadolinium trioxide (see Gadolinium oxide)		
Ethylene (CH ₂ CH ₂)	6	185	Gallium	4	75
			Gallium antimonide (GaSb)	5	300

Material Name	Vol.	Page	Material Name	Vol.	Page
Gallium arsenide (GaAs)	5	307	Graphites (specific types) continued		
Gallium oxide (Ga ₂ O ₃)	5	95	Canadian natural CNG	5	9
Gallium sesquioxide (see Gallium oxide)			Canadian natural boronated CNG-B	5	9
Digallium trioxide (see Gallium oxide)			Ceylon natural graphite		
Gallium phosphide (GaP)	5	520	Graphitized lampblack SA-25	5	9
Gallium telluride (see Digallium tritelluride)			Natural Madagascan	5	9
Digallium tritelluride (Ga ₂ Te ₃)	5	723	Pile H-CS II	5	9
Genetron 11 (see Freon 11)			Pyro	5	9
Genetron 12 (see Freon 12)			Hafnia (see Hafnium dioxide)		
Genetron 13 (see Freon 13)			Hafnium	4	87
Genetron 22 (see Freon 22)			Hafnium + Zirconium	4	356
Genetron 113 (see Freon 113)			Hafnium beryllide (see Dihafnium 21-beryllide)		
Genetron 114 (see Freon 114)			Dihafnium 21-beryllide (Hf ₂ Be ₂₁)	5	313
Germanium	4	79	Hafnium diboride (HfB ₂)	5	341
Germanium tetrahydride (GeH ₄)	5	1033	Hafnium carbide (HfC)	5	420
Germanium oxide (see Germanium dioxide)			Hafnium tetrafluoride (HfF ₄)	5	937
Germanium dioxide (GeO ₂)	5	98	Hafnium nitride (HfN)	5	1081
Germanium silicide, nonstoichiometric (Ge _x Si _y)	5	574	Hafnium dioxide (HfO ₂)	5	101
Glass ceramics (see pyroceram)			Hastelloy B	4	571
Glasses (see individual glass)			Hastelloy C	4	556
Glucinum (see Beryllium)			Hastelloy R-235	4	553
Glucinum sulfate (see Beryllium sulfate)			Haynes stellite, HE 1049	4	526
Glycerin (see Glycerol)			Heavy hydrogen (see Deuterium)		
Glycerol (CH ₂ OHCHOHCH ₂ OH)	6	230	Helium	6	23
Glycol (see Ethylene glycol)			n-Heptane (C ₇ H ₁₆)	6	232
Glycyl alcohol (see Glycerol)			n-Hexane (C ₆ H ₁₄)	6	238
Gold	4	83	High silica glass (SiO ₂ + ΣX _i)	5	1254
Gold + Nickel	4	353	Holmia (see Holmium oxide)		
Graphites (specific types)			Holmium	4	90
Grade 3474 D	5	9	Holmium trichloride hexahydrate (HoCl ₃ ·6H ₂ O)	5	829
Grade 7087	5	9	Holmium oxide (Ho ₂ O ₃)	5	104
Grade ATJ	5	9	Holmium sesquioxide (see Holmium oxide)		
Grade CS	5	9	Diholmium trioxide (see Holmium oxide)		
Grade GBH	5	9	Hydragyrum (see Mercury)		
Acheson	5	9			

Material Name	Vol.	Page	Material Name	Vol.	Page
Hydrogen	6	26	Iron + Chromium, Group I ($25 \leq \text{Cr} < 50$)	4	635
Hydrogen chloride (HCl)	6	72	Iron + Chromium + Manganese, Group I	4	638
Hydrogen iodide (HI)	6	76	Iron + Chromium + Manganese + ΣX_i , Group II ($\text{Cr} < 5.0$)	4	687
Hydrogen sulfide (H_2S)	6	78	Iron + Chromium + Manganese + ΣX_i , Group II ($14 \leq \text{Cr} \leq 27$)	4	690
Inco 713 C	4	550	Iron + Chromium + Nickel + ΣX_i , Group II (15-16 Cr, 4-5 Ni)	4	717
Incoloy	4	726	Iron + Chromium + Nickel + ΣX_i , Group II (17-20 Cr, 8-14 Ni)	4	699
Incoloy 901	4	565	Iron + Chromium + ΣX_i , Group II	4	678
Incoloy alloy 800 (see Incoloy)			Iron + Cobalt + ΣX_i , Group I	4	641
Incoloy alloy 901 (see Incoloy 901)			Iron + Cobalt + ΣX_i (Group I), eutectoid	4	641
Inconel 702 alloy	4	553	Iron + Copper + ΣX_i , Group I	4	644
Inconel alloy	4	553	Iron + Manganese + Carbon, Group I	4	655
Inconel alloy 600 (see Inconel alloy)			Iron + Manganese + Carbon (Group I), eutectoid	4	655
Inconel alloy 702 (see Inconel 702 alloy)			Iron + Manganese + ΣX_i , Group I	4	647
Inconel alloy X-750 (see Inconel X alloy)			Iron + Manganese + ΣX_i , Group I (10 < Mn \leq 50)	4	650
Inconel X alloy	4	553	Iron + Manganese + ΣX_i , Group II	4	723
Indium	4	95	Iron + Nickel, Group II	4	726
Indium + Tin	4	359	Iron + Nickel + Carbon, Group I	4	665
Indium antimonide (InSb)	5	303	Iron + Nickel + Chromium + ΣX_i , Group II	4	729
Indium arsenide (InAs)	5	310	Iron + Nickel + ΣX_i , Group I	4	660
Indium phosphide (InP)	5	523	Iron + Silicon + ΣX_i , Group I	4	668
Diindium sulfide, nonstoichiometric (In_2S_x)	5	668	Iron + Silicon + ΣX_i , Group II	4	732
Inquartation silver	4	208	Iron + Tin, Group I	4	672
Invar	4	660	Iron + Titanium, Group I (TiFe_2)	4	675
Iodide titanium	4	257	Iron + Titanium + ΣX_i , Group II	4	735
Iodide zirconium	4	268	Iron + Tungsten + ΣX_i , Group II	4	738
Iodine	5	15	Iron aluminate (see Iron dialuminum tetraoxide)		
Iridium	4	99	Iron dialuminum tetraoxide (FeAl_2O_4)	5	1443
Iron	4	102	Iron carbide (see Triiron carbide)		
Iron, Armco	4	102	Triiron carbide (Fe_3C)	5	424
Iron, electrolytic	4	102	Iron dichloride (FeCl_2)	5	832
Iron + Aluminum, Group I	4	626	Ironous chloride (see Iron dichloride)		
Iron + Antimony, Group I	4	629			
Iron + Carbon + ΣX_i , Group I	4	619			
Iron + Carbon + ΣX_i , Group II	4	623			
Iron + Chromium, Group I ($8 \leq \text{Cr} < 25$)	4	632			

Material Name	Vol.	Page	Material Name	Vol.	Page
Iron chromite (see Iron dichromium tetraoxide)			Iron sulfide (FeS)	5	674
Iron dichromium tetraoxide (FeCr ₂ O ₄)	5	1446	Iron disulfide (FeS ₂)	5	677
Iron cobaltite (see Iron dicobalt tetraoxide)			Iron sulfide, nonstoichiometric (Fe _x S)	5	671
Iron dicobalt tetraoxide (FeCo ₂ O ₄)	5	1449	Iron tellurides:		
Iron difluoride (FeF ₂)	5	940	FeTe ₂	5	729
Iron oxides:			Fe _x Te (nonstoichiometric)	5	726
FeO	5	107	Iron ditelluride (FeTe ₂)	5	729
Fe ₂ O ₃	5	110	Iron telluride, nonstoichiometric (Fe _x Te)	5	726
Fe ₃ O ₄	5	114	Iron titanate (see Iron titanium trioxide)		
Diiron trioxide [see Iron(ic) oxide]			Iron titanium trioxide (FeTiO ₃)	5	1455
Triiron tetraoxide (Fe ₃ O ₄)	5	114	Iron vitriol (see Iron sulfate heptahydrate)		
Iron selenides:			Iron(ic) oxide (Fe ₂ O ₃)	5	110
FeS ₂	5	527	Iron(ous) oxide (FeO)	5	107
Fe ₃ S ₄	5	536	Isotron 11 (see Freon 11)		
Fe ₇ Se ₈	5	533	Isotron 12 (see Freon 12)		
Fe _x Se (nonstoichiometric)	5	530	Isotron 13 (see Freon 13)		
Iron diselenide (FeSe ₂)	5	527	Isotron 22 (see Freon 22)		
Triiron tetraselenide (Fe ₃ Se ₄)	5	536	Isotron 113 (see Freon 113)		
Heptairon octaselenide (Fe ₇ Se ₈)	5	533	Isotron 114 (see Freon 114)		
Iron selenide, nonstoichiometric (Fe _x Se)	5	530	Jodium (see Iodine)		
Iron silicides:			Kalium (see Potassium)		
FeSi	5	577	Krypton	6	34
Fe ₂ Si	5	583	Lanthana (see Lanthanum oxide)		
Fe ₅ Si ₃	5	580	Lanthanum	4	110
Iron silicide (FeSi)	5	577	Lanthanum oxide (La ₂ O ₃)	5	118
Triiron silicide (Fe ₃ Si)	5	583	Lanthanum sesquioxide (see Lanthanum oxide)		
Pentairon trisilicide (Fe ₅ Si ₃)	5	580	Dilantanum trioxide (see Lanthanum oxide)		
Iron orthosilicate (see Diiron silicon tetraoxide)			Laughing gas (see Nitrous oxide)		
Diiron silicon tetraoxide (Fe ₂ SiO ₄)	5	1452	Lead	4	113
Iron sulfate heptahydrate (FeSO ₄ ·7H ₂ O)	5	1200	Lead + Tin	4	363
Iron sulfides:			Lead - tin solder (Sn + Pb)	4	446
FeS	5	674	Lead glance (see Lead sulfide)		
FeS ₂	5	677	Lead dioxide (PbI ₂)	5	497
Fe _x S (nonstoichiometric)	5	671	Lead molybdate (see Lead molybdenum tetraoxide)		

Material Name	Vol.	Page	Material Name	Vol.	Page
Lead molybdenum tetraoxide (PbMoO ₄)	5	1458	Lithium fluoride (LiF)	5	943
Lead oxides:			Lithium hexafluoroaluminate (see Trilithium aluminum hexafluoride)		
PbO	5	122	Lithium hydride (LiH)	5	1036
PbO ₂	5	125	Lithium monohydrogen difluoride (LiHF ₂)	5	953
Pb ₂ O ₃	5	128	Lithium iron dioxide (LiFeO ₂)	5	1467
Pb ₃ O ₄	5	131	Lithium iron tetraoxide, nonstoichiometric (Li _x Fe _y O ₄)	5	1470
Lead oxide (PbO)	5	122	Lithium oxide (Li ₂ O)	5	134
Lead dioxide (PbO ₂)	5	125	Dilithium oxide (see Lithium oxide)		
Lead monoxide (see Lead oxide)			Lithium titanate (see Dilithium titanium trioxide)		
Lead peroxide (see Lead dioxide)			Lithium metatitanate (see Dilithium titanium trioxide)		
Lead protoxide (see Lead oxide)			Dilithium titanium trioxide (Li ₂ TiO ₃)	5	1473
Lead sesquioxide (Pb ₂ O ₃)	5	128	Lithium zinc ferrite [see Lithium zinc iron tetraoxide (nonstoichiometric)]		
Lead superoxide (see Lead dioxide)			Lithium zinc iron tetraoxide, nonstoichiometric (Li _x Zn _y Fe _z O ₄)	5	1476
Dilead trioxide (see Lead sesquioxide)			Lutetia (see Lutetium sesquioxide)		
Trilead tetraoxide (Pb ₃ O ₄)	5	131	Lutetium	4	121
Lead sulfide (PbS)	5	681	Lutetium sesquioxide (Lu ₂ O ₃)	5	157
Lead tungstate (see Lead tungsten tetraoxide)			Dilutetium trioxide (see Lutetium sesquioxide)		
Lead tungsten tetraoxide (PbWO ₄)	5	1461	Magnesia (see Magnesium oxide)		
Lead wolframate (see Lead tungsten tetraoxide)			Magnesium	4	124
Libbey-Owens-Ford plate glass No. 9330	5	1240	Magnesium + Aluminum + ΣX _i	4	535
Lithia (see Lithium oxide)			Magnesium + Silicon	4	369
Lithium	4	117	Magnesium + Thorium + ΣX _i	4	538
Lithium + Magnesium	4	366	Magnesium + Zinc + ΣX _i	4	541
Lithium aluminate (see Lithium aluminum dioxide)			Magnesium alloys (specific types)		
Lithium metaaluminate (see Lithium aluminum dioxide)			AN-M-29	4	535
Trilithium aluminum hexafluoride (Li ₃ AlF ₆)	5	947	AZ-31B	4	535
Lithium aluminum dioxide (LiAlO ₂)	5	1464	AZ-80	4	535
Dilithium beryllium tetrafluoride (Li ₂ BeF ₄)	5	950	HK-31A	4	538
Dilithium carbonate (Li ₂ CO ₃)	5	1118	HM-21XA	4	538
Lithium chloride (LiCl)	5	835	HM-31XA	4	538
Lithium ferrites:			ZK-60A	4	541
LiFeO ₂	5	1467			
Li _x Fe _y O ₄ (nonstoichiometric)	5	1470			

Material Name	Vol.	Page	Material Name	Vol.	Page
Magnesium aluminate (see Magnesium dialuminum tetraoxide)			Magnesium germanide (see Dimagnesium germanide)		
Magnesium metaaluminate (see Magnesium dialuminum tetraoxide)			Dimagnesium germaride (Mg_2Ge)	5	481
Magnesium dialuminum tetraoxide ($MgAl_2O_4$)	5	1479	Magnesium diiron tetraoxide ($MgFe_2O_4$)	5	1485
Magnesium aluminum silicate (see Dimagnesium tetraaluminum pentasilicon 18-oxide)			Magnesium iron tetraoxide, nonstoichiometric ($Mg_xFe_yO_4$)	5	1488
Dimagnesium tetraaluminum pentasilicon 18-oxide ($Mg_2Al_4Si_5O_{18}$)	5	1503	Magnesium molybdate (see Magnesium molybdenum tetraoxide)		
Magnesium borides:			Magnesium molybdenum tetraoxide ($MgMoO_4$)	5	1491
MgB_2	5	345	Magnesium nitride (see Trimagnesium dinitride)		
MgB_4	5	348	Trimagnesium dinitride (Mg_3N_2)	5	1084
Magnesium diboride (MgB_2)	5	345	Magnesium oxide (MgO)	5	140
Magnesium tetraboride (MgB_4)	5	348	Magnesium silicates:		
Magnesium cadmium alloys:			$MgSiO_3$	5	1494
$MgCd$	4	294	Mg_2SiO_4	5	1497
$MgCd_3$	4	300	$Mg_3Si_4O_{11} \cdot H_2O$	5	1500
Mg_3Cd	4	297	Magnesium silicon trioxide ($MgSiO_3$)	5	1497
Magnesium chlorides:			Dimagnesium silicon tetraoxide (Mg_2SiO_4)	5	1497
$MgCl_2$	5	838	Trimagnesium tetrasilicon undecaoxide monohydrate ($Mg_3Si_4O_{11} \cdot H_2O$)	5	1500
$MgCl_2 \cdot H_2O$	5	841	Magnesium titanates:		
$MgCl_2 \cdot 2H_2O$	5	844	$MgTiO_3$	5	1506
$MgCl_2 \cdot 4H_2O$	5	847	$MgTi_2O_5$	5	1509
$MgCl_2 \cdot 6H_2O$	5	850	Mg_2TiO_4	5	1512
Magnesium dichloride ($MgCl_2$)	5	838	Magnesium dititanate (see Magnesium dititanium pentaoxide)		
Magnesium dichloride monohydrate ($MgCl_2 \cdot H_2O$)	5	841	Magnesium metatitanate (see Magnesium titanium trioxide)		
Magnesium dichloride dihydrate ($MgCl_2 \cdot 2H_2O$)	5	844	Dimagnesium titanate (see Dimagnesium titanium tetraoxide)		
Magnesium dichloride tetrahydrate ($MgCl_2 \cdot 4H_2O$)	5	847	Magnesium titanium trioxide ($MgTiO_3$)	5	1506
Magnesium dichloride hexahydrate ($MgCl_2 \cdot 6H_2O$)	5	850	Magnesium dititanium pentaoxide ($MgTi_2O_5$)	5	1509
Magnesium chromite (see Magnesium dichromium tetraoxide)			Dimagnesium titanium tetraoxide (Mg_2TiO_4)	5	1512
Magnesium dichromium tetraoxide ($MgCr_2O_4$)	5	1482	Magnesium tungstate (see Magnesium tungsten tetraoxide)		
Magnesium ferrites:			Magnesium tungsten tetraoxide ($MgWO_4$)	5	1515
$MgFe_2O_4$	5	1485	Magnesium vanadates:		
$Mg_xFe_yO_4$	5	1488	MgV_2O_6	5	1518
Magnesium difluoride (MgF_2)	5	956	$Mg_2V_2O_7$	5	1521

Material Name	Vol.	Page	Material Name	Vol.	Page
Magnesium metavanadate (see Magnesium divanadium hexaoxide)			Manganese sesquioxide (Mn_2O_3)	5	151
Magnesium pyrovanadate (see Magnesium divanadium hexaoxide)			Dimanganese trioxide (see Manganese sesquioxide)		
Magnesium divanadium hexaoxide (MgV_2O_6)	5	1518	Trimanganese tetraoxide (Mn_3O_4)	5	154
Dimagnesium divanadium heptaoxide ($Mg_2V_2O_7$)	5	1521	Manganese (ic) oxide (see Manganese sesquioxide)		
Magnesium wolframate (see Magnesium tungsten tetraoxide)			Manganese (ous) chloride (see Manganese dichloride)		
Manganese	4	127	Manganese (ous) fluoride (see Manganese difluoride)		
Manganese, electrolytic	4	127	Manganese (ous) oxide (see Manganese monoxide)		
Manganese + Aluminum	4	372	Manganese (ous) sulfide (see Manganese sulfide)		
Manganese + Copper	4	377	Manganese selenide (see Manganous selenide)		
Manganese + Nickel	4	380	Manganese silicate (see Manganese silicon trioxide)		
Manganese aluminum carbide (see Trimanganese aluminum carbide)			Manganese silicides:		
Trimanganese aluminum carbide (Mn_3AlC)	5	427	Mn_3Si	5	586
Manganese carbide (see Trimanganese carbide)			$MnSi_x$ (nonstoichiometric)	5	589
Trimanganese carbide (Mn_3C)	5	433	Trimanganese silicide (Mn_3Si)	5	586
Manganese carbonate ($MnCO_3$)	5	1121	Manganese silicide, nonstoichiometric ($MnSi_x$)	5	589
Manganese chlorides:			Manganese silicon trioxide ($MnSiO_3$)	5	1524
$MnCl_2$	5	853	Manganese sulfide (MnS)	5	684
$MnCl_2 \cdot 4H_2O$	5	856	Manganese monosulfide (see Manganese sulfide)		
Manganese dichloride ($MnCl_2$)	5	853	Manganese telluride (see Manganous telluride)		
Manganese dichloride tetrahydrate (see Manganous dichloride tetrahydrate)			Manganese zinc carbide (see Trimanganese zinc carbide)		
Manganese difluoride (MnF_2)	5	959	Trimanganese zinc carbide (Mn_3ZnC)	5	430
Manganese oxides:			Manganin	4	338
MnO	5	145	Manganomanganic oxide (see Trimanganese tetraoxide)		
MnO_2	5	148	Manganese dichloride tetrahydrate ($MnCl_2 \cdot 4H_2O$)	5	856
Mn_2O_3	5	151	Manganous selenide ($MnSe$)	5	539
Mn_3O_4	5	154	Manganous telluride ($MnTe$)	5	732
Manganese binoxide (see Manganese dioxide)			Marsh gas (see Methane)		
Manganese dioxide (MnO_2)	5	148	Mercuric oxide [see Mercury (ic) oxide]		
Manganese monoxide (MnO)	5	145			
Manganese peroxide (see Manganese dioxide)					
Manganese protoxide (see Manganese monoxide)					

Material Name	Vol.	Page	Material Name	Vol.	Page
Mercuric selenide (see Mercury selenide)			Molybdenum silicides:		
Mercury	4	131	MoSi ₂	5	592
Mercury selenide (HgSe)	5	542	Mo ₃ Si	5	595
Dimercury sulfate (Hg ₂ SC ₄)	5	1203	Molybdenum disilicide (MoSi ₂)	5	592
Mercury sulfide (HgS)	5	687	Trimolybdenum silicide (Mo ₃ Si)	5	595
Mercury (ic) oxide (HgO)	5	157	Molybdenum sulfide (see Molybdenum di-sulfide)		
Methane (CH ₄)	6	244	Molybdenum disulfide (MoS ₂)	5	690
Methanol (see Methyl alcohol)			Mond nickel	4	146
Methyl alcohol (CH ₃ OH)	6	252	Monel alloy	4	562
Methyl chloride (CH ₃ Cl)	6	257	Monel alloy 400 (see Monel alloy)		
Methylbenzene (see Toluene)			Monel alloy K-50C (see Monel K alloy)		
Methylmethane (see Ethane)			Monel K alloy	4	562
Molybdenum	4	135	MSM-70 (see Titanium, Ti-75 A)		
Molybdenum + Titanium	4	383	MSM-2.5 Al-16V (see Titanium alloy Ti-2.5Al-16V)		
Molybdenum + Titanium + ΣX ₁	4	544	MSM-6Al-4V (see Titanium alloy Ti-6Al-4V)		
Molybdenum + Tungsten	4	386	MSM-8Mn (see Titanium alloy C-110 M)		
Molybdenum beryllide (see Molybdenum dodecaberyllide)			MST-2.5 Al-16V (see Titanium alloy Ti-2.5Al-16V)		
Molybdenum dodecaberyllide (MoBe ₁₂)	5	316	MST-6Al-4V (see Titanium alloy Ti-6Al-4V)		
Molybdenum borides:			MST-8Mn (see Titanium alloy C-110M)		
MoB	5	358	Natrium (see Sodium)		
MoB ₂	5	352	Neodymia (see Neodymium oxide)		
Mo ₂ B	5	355	Neodymium	4	140
Molybdenum boride (MoB)	5	358	Neodymium trichloride hexahydrate (NdCl ₃ ·6H ₂ O)	5	859
Molybdenum diboride (MoB ₂)	5	352	Neodymium gallate (see Trineodymium pentagallium dodecaoxide)		
Dimolybdenum boride (Mo ₂ B)	5	355	Trineodymium pentagallium dodecaoxide [Nd ₃ Ga ₅ O ₁₂ (Garnet)]	5	1527
Molybdenum carbide (see Dimolybdenum carbide)			Neodymium oxide (Nd ₂ O ₃)	5	166
Dimolybdenum carbide (Mo ₂ C)	5	436	Neodymium sesquioxide (see Neodymium oxide)		
Molybdenum hexafluoride (MoF ₆)	5	962	Neon	6	37
Molybdenum oxides:			Neptunium	4	143
MoO ₂	5	160	Neptunium + Calcium + ΣX ₁	4	547
MoO ₃	5	163	Neptunium dioxide (NpO ₂)	5	169
Molybdenum dioxide (MoO ₂)	5	160			
Molybdenum trioxide (MoO ₃)	5	163			

Material Name	Vol.	Page	Material Name	Vol.	Page
Nichrome V	4	556	Nickel alloys (specific types) continued		
Nickel	4	146	OKh 20 N60 B	4	559
Nickel, electrolytic	4	146	Rene 41	4	556
Nickel, mond	4	146	Nickel chlorides:		
Nickel + Aluminum	4	389	NiCl ₂	5	863
Nickel + Chromium	4	392	NiCl ₂ ·6H ₂ O	5	866
Nickel + Chromium + ΣX _i (9 ≤ Cr ≤ 11)	4	550	Nickel dichloride (NiCl ₂)	5	863
Nickel + Chromium + ΣX _i (15 ≤ Cr ≤ 16)	4	553	Nickel dichloride hexahydrate (NiCl ₂ ·6H ₂ O)	5	866
Nickel + Chromium + ΣX _i (18 ≤ Cr < 20)	4	556	Nickel ferrites:		
Nickel + Chromium + ΣX _i (Cr > 20)	4	559	NiFe ₂ O ₄	5	1530
Nickel + Copper	4	398	Ni _x Fe _y O ₄ (nonstoichiometric)	5	1533
Nickel + Copper + ΣX _i	4	562	Nickel difluoride (NiF ₂)	5	973
Nickel + Iron	4	403	Nickel fluosilicate hexahydrate (A) (NiSiF ₆ ·6H ₂ O)	5	966
Nickel + Iron + ΣX _i	4	365	Nickel fluosilicate hexahydrate (B) (NiSiF ₆ ·6H ₂ O)	5	970
Nickel + Magnesium (MgNi ₂)	4	407	Nickel diiron tetraoxide (NiFe ₂ O ₄)	5	1530
Nickel + Manganese	4	410	Nickel iron tetraoxide, nonstoichiometric (Ni _x Fe _y O ₄)	5	1533
Nickel + Manganese + ΣX _i	4	568	Nickel oxide (NiO)	5	172
Nickel + Molybdenum + ΣX _i	4	371	Nickel monoxide (see Nickel oxide)		
Nickel + Silicon	4	413	Nickel protoxide (see Nickel oxide)		
Nickel + Tungsten (Ni ₄ W)	4	416	Nickel selenides:		
Nickel + Zinc	4	419	NiSe ₂	5	549
Nickel alloys (specific types):			Ni _x Se (nonstoichiometric)	5	545
60Ni 15Cr (ASTM B83-46)	4	565	Nickel diselenide (NiSe ₂)	5	549
80 Ni 20Cr	4	556	Nickel selenide, nonstoichiometric (Ni _x Se)	5	515
90 Ni 10Cr	4	550	Nickel sulfate hexahydrate (NiSO ₄ ·6H ₂ O)	5	1206
Alumel	4	503	Nickel sulfides:		
Chromel A (see Nickel alloy Nichrome V)			NiS	5	693
Chromel-P	4	392	Ni ₃ S ₂	5	696
EI-435	4	559	Nickel sulfide (NiS)	5	693
GE J 1500 (same as M252)			Tritnickel disulfide (Ni ₃ S ₂)	5	696
GEJ 1610 (same as Rene 41)			Nickel tellurides:		
M252	4	556	NiTe ₂	5	738
Monel	4	562	NiTe _x (nonstoichiometric)	5	735
Nichrome V	4	556	Nickel ditelluride (NiTe ₂)	5	738
OKh 21 N78 T	4	559			

Material Name	Vol.	Page	Material Name	Vol.	Page
Nickel telluride, nonstoichiometric (NiTe _x)	5	735	Niobium pentafluoride (NbF ₅)	5	976
Nickel zinc ferrite [see Nickel zinc diiron tetraoxide (nonstoichiometric)]			Niobium oxides:		
Nickel zinc diiron tetraoxide [Ni _x Zn _y Fe ₂ O ₄ (nonstoichiometric)]	5	1536	NbO	5	175
Nickel (ous)oxide (see Nickel oxide)			NbO ₂	5	178
Niobium	4	153	Nb ₂ O ₅	5	181
Niobium + Iron + ΣX _i	4	574	Niobium monoxide (NbO)	5	175
Niobium + Molybdenum + ΣX _i	4	577	Niobium dioxide (NbO ₂)	5	178
Niobium + Tantalum + ΣX _i	4	580	Diniobium pentaoxide (Nb ₂ O ₅)	5	181
Niobium + Titanium + ΣX _i	4	583	Nitric oxide (NO)	6	83
Niobium + Tungsten + ΣX _i	4	586	Nitrogen	6	39
Niobium + Zirconium	4	422	Nitrogen peroxide (NO ₂)	6	90
Niobium alloys (specific types)			Nitrous oxide (N ₂ O)	6	92
5 Mo-5 V-1 Zr	4	577	n-Nonane (C ₉ H ₂₀)	6	261
27 Ta-12 W-0.5 Zr	4	580	n-Octane (C ₈ H ₁₈)	6	266
10 Ti-5 Zr	4	583	OFHC copper	4	51
15 W-5 Mo-1 Zr-0.05 C	4	586	Olefiant gas (see Ethylene)		
10 W-5 Zr	4	586	Osmium	4	157
10 W-1 Zr-0.1 C	4	586	Oxygen	6	48
CB-752	4	586	Palladium	4	160
D-36 (see Niobium alloy 10 W-5 Zr)			Palladium + Silver	4	425
F-48	4	586	Palladium tellurides:		
Ferroniobium	4	574	PdTe	5	741
FS-82 B	4	580	PdTe ₂	5	744
Niobium dodecaberyllide (NbBe ₁₂)	5	319	Palladium telluride (PdTe)	5	741
Niobium borides:			Palladium ditelluride (PdTe ₂)	5	744
NbB ₂	5	365	Pearlite	4	655
NbB _x (nonstoichiometric)	5	361	n-Pentane (C ₅ H ₁₂)	6	272
Niobium diboride (NbB ₂)	5	365	Perchloromethane (see Carbon tetrachloride)		
Niobium boride, nonstoichiometric (NbB _x)	5	361	Phenylmethane (see Toluene)		18
Niobium carbides:			Phosphorus	5	18
NbC	5	442	Phosphorus, black	5	18
NbC _x (nonstoichiometric)	5	439	Phosphorus trichloride (PCl ₃)	5	869
Niobium carbide (NbC)	5	442	Phosphorus (ous) chloride (see Phosphorus trichloride)		
Niobium carbide, nonstoichiometric (NbC _x)	5	439	Pittsburgh No. 3235 glass	5	1230

Material Name	Vol.	Page	Material Name	Vol.	Page
Plate glass No. 9330	5	1240	Potassium nitrate (KNO ₃)	5	1145
Platinum	4	163	Potassium dioxide (see Potassium superoxide)		
Platinum sulfides:			Potassium superoxide (KO ₂)	5	184
PtS	5	699	Dipotassium sulfate (K ₂ SO ₄)	5	1209
PtS ₂	5	702	Praseodymium	4	177
Platinum sulfide (PtS)	5	699	Praseodymium oxide (see Hexapraseodymium undeca-oxide)		
Platinum disulfide (PtS ₂)	5	702	Hexapraseodymium undeca-oxide (Pr ₆ O ₁₁)	5	187
Platinum tellurides:			Propane (C ₃ H ₈)	6	279
PtTe	5	747	2-Propanone (see Acetone)		
PtTe ₂	5	750	Pyrex 774	5	1230
Platinum telluride (PtTe)	5	747	Pyrex glasses	5	1230
Platinum ditelluride (PtTe ₂)	5	750	Pyroacetic ether (see Acetone)		
Plutonium	4	167	Pyroceram	5	1237
Plutonium + Cerium + ΣX _i	4	589	Pyroceram 9606	5	1237
Plutonium carbide (PuC)	5	445	Pyroceram 9608	5	1237
Plutonium dioxide (PuO ₂)	5	190	Quartz	5	207
Potassium	4	171	Quartz crystal	5	207
Potassium + Sodium	4	428	Quartz glass	5	202
Potassium aluminum silicates:			Quick silver (see Mercury)		
KAl ₃ Si ₃ O ₁₁	5	1540	RC-70 (see Titanium, Ti-75 A)		
KAl ₃ Si ₃ O ₁₁ ·H ₂ O	5	1543	Rene 41	4	556
Potassium trialuminum trisilicon undeca-oxide (KAl ₃ Si ₃ O ₁₁)	5	1540	Rhenium	4	181
Potassium trialuminum trisilicon undeca-oxide monohydrate (KAl ₃ Si ₃ O ₁₁ ·H ₂ O)	5	1543	Rhenium trichloride (ReCl ₃)	5	878
Potassium aluminum sulfates:			Rhodium	4	184
KAl(SO ₄) ₂	5	1212	RS-70 (see Titanium, Ti-75 A)		
KAl(SO ₄) ₂ ·12H ₂ O	5	1215	Rubidium	4	187
Potassium aluminum disulfate [KAl(SO ₄) ₂]	5	1212	Rubidium bromide (RbBr)	5	769
Potassium aluminum disulfate dodecahydrate [KAl(SO ₄) ₂ ·12H ₂ O]	5	1215	Rubidium fluoride (RbF)	5	985
Potassium bromide (KBr)	5	765	Rubidium monohydrogen difluoride (RbHF ₂)	5	988
Dipotassium carbonate (K ₂ CO ₃)	5	1124	Rubidium iodide (RbI)	5	503
Potassium chloride (KCl)	5	872	Ruthenium	4	190
Potassium fluoride (KF)	5	979	Rutile (see Titanium dioxide)		
Potassium hydrogen difluoride (KHF ₂)	5	982	SAE 1010	4	647
Potassium iodide (KI)	5	500	Samaria (see Samarium oxide)		

Material Name	Vol.	Page	Material Name	Vol.	Page
Samarium	4	193	Silver selenides:		
Samarium oxide (Sm_2O_3)	5	193	Ag_2Se	5	553
Samarium sesquioxide (see Samarium oxide)			Ag_xSe (nonstoichiometric)	5	556
Disamarium trioxide (see Samarium oxide)			Disilver selenide (Ag_2Se)	5	553
Scandia (see Scandium oxide)			Silver selenide, nonstoichiometric (Ag_xSe)	5	556
Scandium	4	198	Silver sulfide, nonstoichiometric (Ag_xS)	5	705
Scandium oxide (Sc_2O_3)	5	196	Silver tellurides:		
Scandium sesquioxide (see Scandium oxide)			Ag_2Te	5	753
Discandium trioxide (see Scandium oxide)			Ag_xTe (nonstoichiometric)	5	756
Selenium	4	201	Disilver telluride (Ag_2Te)	5	753
Silica (see Silicon dioxide)			Silver telluride, nonstoichiometric (Ag_xTe)	5	756
Silica glass	5	202	Soda lime glass ($\text{SiO}_2 + \text{Na}_2\text{O} + \Sigma\text{X}_i$)	5	1240
Silicon	4	204	Soda-lime silica plate glass (see Soda lime glass)		
Silicon carbide (SiC)	5	448	Sodium	4	213
Silicon carbide + Carbon + ΣX_i , cermet ($\text{SiC} + \text{C} + \Sigma\text{X}_i$)	5	1279	Sodium, electrolytic	4	213
Silicon tetrachloride (SiCl_4)	5	881	Sodium + Potassium (Na_2K)	4	431
Silicon tetrafluoride (SiF_4)	5	991	Trisodium aluminum hexafluoride (Na_3AlF_6)	5	997
Silicon nitride (Si_3N_4) Si_3N_4	5	1087	Sodium aluminate (see Sodium aluminum dioxide)		
Silicon dioxide [SiO_2 (cristobalite)]	5	210	Sodium metaaluminate (see Sodium aluminum dioxide)		
Silicon dioxide [SiO_2 (Quartz crystal)]	5	207	Sodium aluminum dioxide (NaAlO_2)	5	1549
Silicon dioxide [SiO_2 (Quartz glass)]	5	202	Sodium aluminum silicate (see Sodium aluminum trisilicon octaoxide)		
Silicon dioxide [SiO_2 (Tridymite)]	5	213	Sodium aluminum trisilicon octaoxide ($\text{NaAlSi}_3\text{O}_8$)	5	1602
Silicon dioxide + Dialuminum trioxide + ΣX_i ($\text{SiO}_2 + \text{Al}_2\text{O}_3 + \Sigma\text{X}_i$)	5	1546	Sodium tetraborate (see Disodium tetraboron heptaoxide)		
Sillimanite (see Dialuminum silicon pentaoxide)			Sodium borates:		
Silver	4	208	NaBO_2	5	1552
Silver, electrolytic	4	208	$\text{Na}_2\text{B}_4\text{O}_7$	5	1556
Silver, inquartation	4	208	Sodium boron dioxide (NaBO_2)	5	1552
Disilver carbonate (Ag_2CO_3)	5	1127	Disodium tetraboron heptaoxide ($\text{Na}_2\text{B}_4\text{O}_7$)	5	1556
Silver chloride (AgCl)	5	884	Sodium bromide (NaBr)	5	772
Silver nitrite (AgNO_2)	5	1148	Disodium carbonate (Na_2CO_3)	5	1130
Silver oxide (Ag_2O)	5	199	Sodium bicarbonate (NaHCO_3)	5	1133
Disilver oxide (see Silver oxide)			Sodium chloride (NaCl)	5	887

Material Name	Vol.	Page	Material Name	Vol.	Page
Sodium ferrite (see Sodium iron dioxide)			Sodium sulfates:		
Sodium fluoride (NaF)	5	994	Na ₂ SO ₄	5	1218
Sodium hydrogen carbonate (see Sodium bicarbonate)			Na ₂ SO ₄ ·10H ₂ O	5	1221
Sodium hexafluoroaluminate (see Trisodium aluminum hexafluoride)			Disodium sulfate (Na ₂ SO ₄)	5	1218
Sodium monohydrogen difluoride (NaHF ₂)	5	1000	Disodium sulfate decahydrate (Na ₂ SO ₄ ·10H ₂ O)	5	1221
Sodium iodide (NaI)	5	596	Sodium tellurate (see Disodium tellurium tetraoxide)		
Sodium iron dioxide (Na ₂ FeO ₂)	5	1560	Disodium tellurium tetraoxide (Na ₂ TeO ₄)	5	1575
Sodium molybdates:			Sodium titanates:		
Na ₂ MoO ₄	5	1563	Na ₂ TiO ₃	5	1578
Na ₂ Mo ₂ O ₇	5	1566	Na ₂ Ti ₂ O ₅	5	1581
Disodium molybdenum tetraoxide (Na ₂ MoO ₄)	5	1563	Na ₂ Ti ₃ O ₇	5	1584
Disodium dimolybdenum heptaoxide (Na ₂ Mo ₂ O ₇)	5	1566	Sodium dititanate (see Disodium dititanium pentaoxide)		
Sodium nitrate (NaNO ₃)	5	1151	Sodium metatitanate (see Disodium titanium trioxide)		
Sodium oxides:			Sodium trititanate (see Disodium trititanium heptaoxide)		
Na ₂ O	5	216	Disodium titanium trioxide (Na ₂ TiO ₃)	5	1578
NaO ₂	5	222	Disodium dititanium pentaoxide (Na ₂ Ti ₂ O ₅)	5	1581
Na ₂ O ₂	5	219	Disodium trititanium heptaoxide (Na ₂ Ti ₃ O ₇)	5	1584
Sodium oxide (Na ₂ O)	5	216	Sodium tungstates:		
Sodium superoxide (NaO ₂)	5	222	Na ₂ WO ₄	5	1587
Sodium peroxide (Na ₂ O ₂)	5	219	Na ₂ W ₂ O ₇	5	1590
Sodium dioxide (see Sodium superoxide)			Disodium tungsten tetraoxide (Na ₂ WO ₄)	5	1587
Disodium oxide (see Sodium oxide)			Disodium ditungsten heptaoxide (Na ₂ W ₂ O ₇)	5	1590
Disodium monoxide (see Sodium oxide)			Sodium vanadates:		
Sodium silicates:			NaVO ₃	5	1593
Na ₂ SiO ₃	5	1569	Na ₃ VO ₄	5	1596
Na ₂ Si ₂ O ₅	5	1572	Na ₄ V ₂ O ₇	5	1599
Sodium disilicate (see Disodium disilicon pentaoxide)			Sodium metavanadate (see Sodium vanadium trioxide)		
Sodium metasilicate (see Disodium silicon trioxide)			Sodium orthovanadate (see Trisodium vanadium tetraoxide)		
Sodium silicate glass No. 23	5	1240	Sodium pyrovanadate (see Tetrasodium divanadium heptaoxide)		
Disodium silicon trioxide (Na ₂ SiO ₃)	5	1569	Sodium vanadium trioxide (NaVO ₃)	5	1593
Disodium disilicon pentaoxide (Na ₂ Si ₂ O ₅)	5	1572	Trisodium vanadium tetraoxide (Na ₃ VO ₄)	5	1596

Material Name	Vol.	Page	Material Name	Vol.	Page
Tetrasodium divanadium heptaoxide ($\text{Na}_4\text{V}_2\text{O}_7$)	5	1599	Steels (specific types) continued		
Solex 2808 plate glass	5	1240	Steel 19	4	687
Solex S plate glass	5	1240	Stellite HE 1049	4	526
Stainless steels (specific types)			T-261	4	655
1 KH 18 N9T	4	699	T-262	4	655
17-4 PH	4	717	T-270	4	655
17-7 PH	4	696	T-278	4	655
AISI 301	4	693	T-279	4	655
AISI 304	4	699	T-310	4	655
AISI 305	4	702	T-311	4	655
AISI 310	4	705	Stibium (see Antimony)		
AISI 316	4	708	Strontia (see Strontium oxide)		
AISI 347	4	711	Strontium	4	218
AISI 420	4	678	Strontium bromide (SrBr)	5	775
AISI 430	4	681	Strontium carbonate (SrCO_3)	5	1136
AISI 446	4	684	Strontium chloride (see Strontium dichloride)		
AM 355	4	717	Strontium dichloride (SrCl_2)	5	890
Austenite	4	655	Strontium difluoride (SrF_2)	5	1003
EI 257	4	720	Strontium nitrate (SrNO_3 $\text{Sr}(\text{NO}_3)_2$)	5	1154
EI 855	4	726	Strontium oxide (SrO)	5	225
HMN Crucible	4	714	Strontium silicates:		
Stannia (see Tin dioxide)			SrSiO_3	5	1605
Stannic oxide (see Tin dioxide)			Sr_2SiO_4	5	1608
Stannous oxide (see Tin monoxide)			Strontium silicon trioxide (SrSiO_3)	5	1605
Steel, austenite	4	655	Distrontium silicon tetraoxide (Sr_2SiO_4)	5	1608
Steel, eutectoid	4	655	Strontium sulfides:		
Steel, pearlite	4	655	SrS	5	708
Steels (specific types)			SrS_2	5	711
4 Kh 13	4	690	Strontium sulfide (SrS)	5	708
Mark 1 X 18 N9T	4	699	Strontium disulfide (SrS_2)	5	711
Mark 12 MX	4	723	Strontium titanates:		
Mild steel	4	647	SrTiO_3	5	1611
OKh 16N 36V 3T	4	726	Sr_2TiO_4	5	1614
Stainless steels (see separate entries under stainless steels)			Strontium metatitanate (see Strontium titanium trioxide)		

Material Name	Vol.	Page	Material Name	Vol.	Page
Strontium orthotitanate (see Distrontium titanium tetraoxide)			Tellurium dioxide (TeO ₂)	5	231
Strontium titanium trioxide (SrTiO ₃)	5	1611	Terbium	4	232
Distrontium titanium tetraoxide (Sr ₂ TiO ₄)	5	1614	Tetrachloromethane (see Carbon tetrachloride)		
Strontium zirconate (see Strontium zirconium trioxide)			Thallium	4	237
Strontium zirconium trioxide (SrZrO ₃)	5	1617	Thallium + Lead (PbTl ₂)	4	437
Sulfur	5	21	Thallium monohydrogen difluoride (TlHF ₂)	5	1006
Sulfur dioxide (SO ₂)	6	97	Thallium nitrate (TlNO ₃)	5	1157
Sulfuretted hydrogen (see Hydrogen sulfide)			Thoria (see Thorium dioxide)		
Sulfuric ether (see Ethyl ether)			Thorium	4	242
Tantalum	4	221	Thorium tetraboride (ThB ₄)	5	375
Tantalum + Niobium + ΣX ₁	4	592	Thorium carbide, nonstoichiometric (ThC _x)	5	454
Tantalum + Tungsten	4	434	Thorium tetrafluoride (ThF ₄)	5	1009
Tantalum + Tungsten + ΣX ₁	4	595	Thorium dioxide (ThO ₂)	5	234
Tantalum alloys (specific types)			Thulium	4	245
30 Nb - 7.5 V	4	592	Tin	4	249
8 W - 2 Hf	4	595	Tin, grey	4	249
Tantalum beryllides:			Tin, white	4	249
TaBe ₁₂	5	322	Tin + Bismuth	4	440
Ta ₂ Be ₁₇	5	325	Tin + Indium	4	443
Tantalum dodecaberyllide (TaBe ₁₂)	5	322	Tin + Lead	4	446
Ditantalum 17-beryllide (Ta ₂ Be ₁₇)	5	325	Tin + Magnesium (Mg ₂ Sn)	4	449
Tantalum borides:			Tin oxides:		
TaB	5	372	SnO	5	237
TaB ₂	5	368	SnO ₂	5	240
Tantalum boride (TaB)	5	372	Tin monoxide (SnO)	5	237
Tantalum diboride (TaB ₂)	5	368	Tin dioxide (SnO ₂)	5	240
Tantalum carbide (TaC)	5	451	Titania (see Titanium dioxide)		
Ditantalum hydride (Ta ₂ H)	5	1040	Titanium	4	257
Tantalum nitride (TaN)	5	1090	Titanium, TI-75 A	4	257
Ditantalum pentaoxide (Ta ₂ O ₅)	5	228	Titanium + Aluminum + ΣX ₁	4	598
Tantalum disilicide (TaSi ₂)	5	598	Titanium + Chromium + ΣX ₁	4	601
Telluric acid anhydride (see Tellurium dioxide)			Titanium + Iron + Cobalt	4	604
Tellurite (see Tellurium dioxide)			Titanium + Manganese	4	453
Tellurium	4	229	Titanium + Molybdenum	4	456
			Titanium + Vanadium + ΣX ₁	4	607

Material Name	Vol.	Page	Material Name	Vol.	Page
Titanium alloys (specific types)			Titanium hydrides - continued		
AMS 4928 (same as Ti-6Al-4V)	4	598	TiH _x (nonstoichiometric)	5	1044
C-110 M	4	543	Titanium dihydride (TiH ₂)	5	1047
C-120 AV (same as Ti-6Al-4V)	4	598	Titanium hydride, nonstoichiometric (TiH _x)	5	1044
M-6	4	456	Titanium tetraiodide (TiI ₄)	5	510
M-8	4	456	Titanium nitride (TiN)	5	1093
M-9	4	456	Titanium oxides:		
M-10	4	456	TiO	5	243
MSM-2.5Al-16V (same as Ti-2.5Al-16V)	4	607	TiO ₂	5	246
MSM-6Al-4V (same as Ti-6Al-4V)	4	598	Ti ₂ O ₃	5	250
MSM-8Mn (same as C-110M)	4	543	Ti ₃ O ₅	5	256
MST-2.5Al-16V (same as Ti-2.5Al-16V)	4	607	Titanium monoxide (TiO)	5	243
MST-6Al-4V (same as Ti-6Al-4V)	4	598	Titanium dioxide (TiO ₂)	5	246
MST-8Mn (same as C-110M)	4	543	Titanium sesquioxide (Ti ₂ O ₃)	5	250
RC-130 A (same as C-110M)	4	543	Trititanium pentaoxide (Ti ₃ O ₅)	5	253
RS-110 A (same as C-110M)	4	543	Titanium silicides:		
Ti-4Al-3Mo-1V	4	598	TiSi	5	601
Ti-2.5Al-16V	4	607	TiSi ₂	5	604
Ti-6Al-4V	4	598	Ti ₅ Si ₃	5	607
Ti-8Mn (same as C-110M)	4	543	Titanium silicide (TiSi)	5	601
Ti-13V-11Cr-3Al	4	607	Titanium disilicide (TiSi ₂)	5	604
Titanium beryllide (see Titanium dodecaberlyllide)			Pentatitanium trisilicide (Ti ₅ Si ₃)	5	607
Titanium dodecaberlyllide (TiBe ₁₂)	5	328	Toluene (C ₆ H ₅ CH ₃)	6	285
Titanium diboride (TiB ₂)	5	378	Trichlorofluoromethane (see Freon 11)		
Titanium bromides:			Trichloromethane (see Chloroform)		
TiBr ₃	5	778	Trichlorotrifluoroethane (see Freon 113)		
TiBr ₄	5	781	Tridymite [see Silicon dioxide (tridymite)]		
Titanium tribromide (TiBr ₃)	5	778	Tungsten	4	263
Titanium tetrabromide (TiBr ₄)	5	781	Tungsten + Cobalt (Co ₇ W ₆)	4	459
Titanium carbide (TiC)	5	457	Tungsten + Iron (Fe ₇ W ₆)	4	462
Titanium trichloride (TiCl ₃)	5	893	Tungsten borides:		
Titanium tetrafluoride (TiF ₄)	5	1012	WB	5	382
Titanium hydrides:			W ₂ B	5	385
TiH ₂	5	1047	W ₂ B ₅	5	388
			Tungsten boride (WB)	5	382

A24

Material Name	Vol.	Page	Material Name	Vol.	Page
Ditungsten boride (W ₂ B)	5	385	Uranium nitride (UN)	5	1096
Ditungsten pentaboride (W ₂ B ₅)	5	388	Uranium nitride, nonstoichiometric (UN _x)	5	1099
Tungsten carbide (WC)	5	460	Uranium oxides:		
Tungsten carbide + Cobalt, cermet (WC + Co)	5	1282	UO ₂	5	259
Tungsten trioxide (WO ₃)	5	256	UO ₃	5	262
Tungsten disilicide (WSi ₂)	5	610	U ₃ O ₈	5	265
Tungstic acid anhydride (see Tungsten trioxide)			U ₄ O ₉	5	269
Uranic chloride (see Uranium tetrachloride)			Uranium dioxide (UO ₂)	5	259
Uranic iodide (see Uranium tetraiodide)			Uranium trioxide (UO ₃)	5	262
Uranic oxide (see Uranium dioxide)			Triuranium octaoxide (U ₃ O ₈)	5	265
Uranium	4	268	Tetrauranium enneaoxide (see Tetrauranium nonaoxide)		
Uranium carbides:			Tetrauranium nonaoxide (U ₄ O ₉)	5	269
UC	5	463	Uranium silicides:		
UC ₂	5	466	USi ₂	5	619
U ₂ C ₃	5	472	USi ₃	5	616
UC _x (nonstoichiometric)	5	469	U ₃ Si	5	613
Uranium carbide (UC)	5	433	U ₃ Si ₂ + U ₃ Si	5	622
Uranium dicarbide (UC ₂)	5	466	Uranium disilicide (USi ₂)	5	619
Diuranium tricarbide (U ₂ C ₃)	5	472	Uranium trisilicide (USi ₃)	5	616
Uranium carbide, nonstoichiometric (UC _x)	5	469	Triuranium silicide (U ₃ Si)	5	613
Uranium chlorides:			Triuranium disilicide + Triuranium monosilicide (U ₃ Si ₂ + U ₃ Si)	5	622
UCl ₃	5	896	Uranous uranic oxide (see Triuranium octaoxide)		
UCl ₄	5	899	Uranyl oxide (see Uranium trioxide)		
Uranium trichloride (UCl ₃)	5	896	Uranyl uranate (see Triuranium octaoxide)		
Uranium tetrachloride (UCl ₄)	5	899	Vanadic anhydride (see Divanadium pentaoxide)		
Uranium fluorides:			Vanadium	4	271
UF ₄	5	1015	Vanadium + Aluminum	4	465
UF ₆	5	1018	Vanadium + Antimony	4	468
Uranium tetrafluoride (UF ₄)	5	1015	Vanadium + Iron	4	471
Uranium hexafluoride (UF ₆)	5	1018	Vanadium + Tin	4	474
Uranium trihydride (UH ₃)	5	1050	Vanadium + Titanium	4	477
Uranium tetraiodide (UI ₄)	5	513	Vanadium carbide (VC)	5	475
Uranium nitrides:					
UN	5	1096			
UN _x (nonstoichiometric)	5	1099			

Material Name	Vol.	Page	Material Name	Vol.	Page
Vanadium chlorides:			Triytterbium pentagallium dodecaoxide [Yb ₃ Ga ₅ O ₁₂ (Garnet)]	5	1620
VCl ₂	5	902	Ytterbium oxide (Yb ₂ O ₃)	5	284
VCl ₃	5	905	Ytterbium sesquioxide (see Ytterbium oxide)		
Vanadium dichloride (VCl ₂)	5	902	Diytterbium trioxide (see Ytterbium oxide)		
Vanadium trichloride (VCl ₃)	5	905	Yttria (see Yttrium oxide)		
Vanadium trifluoride (VF ₃)	5	1021	Yttrium	4	278
Vanadium hydride, nonstoichiometric (VH _x)	5	1053	Yttrium deuterides:		
Vanadium nitride (VN)	5	1103	YD ₂	5	1062
Vanadium oxides:			YD ₃	5	1066
VO	5	272	Yttrium dideuteride (YD ₂)	5	1062
V ₂ O ₃	5	275	Yttrium trideuteride (YD ₃)	5	1066
V ₂ O ₄	5	278	Yttrium gallate (see Triyttrium pentagallium dodecaoxide)		
V ₂ O ₅	5	281	Triyttrium pentagallium dodecaoxide [Y ₃ Ga ₅ O ₁₂ (Garnet)]	5	1623
Vanadium monoxide (VO)	5	272	Yttrium hydrides:		
Vanadium sesquioxide (V ₂ O ₃)	5	275	YH ₂	5	1056
Divanadium tetraoxide (V ₂ O ₄)	5	278	YH ₃	5	1059
Divanadium pentaoxide (V ₂ O ₅)	5	281	Yttrium dihydride (YH ₂)	5	1056
Vanadium silicides:			Yttrium trihydride (YH ₃)	5	1059
VSi ₂	5	628	Yttrium oxide (Y ₂ O ₃)	5	287
V ₃ Si	5	625	Yttrium sesquioxide (see Yttrium oxide)		
V ₅ Si ₃	5	631	Diyttrium trioxide (see Yttrium oxide)		
Vanadium disilicide (VSi ₂)	5	628	Zinc	4	281
Trivanadium silicide (V ₃ Si)	5	625	Zinc + Copper	4	480
Pentavanadium trisilicide (V ₅ Si ₃)	5	631	Zinc + Magnesium (MgZn ₂)	4	483
Vycor 7900	5	1324	Zinc + Zirconium (ZrZn ₂)	4	486
Vycor glasses	5	1234	Zinc dichloride (ZnCl ₂)	5	908
Water (H ₂ O)	6	102	Zinc ferrite (see Zinc diiron tetraoxide)		
Wolfram (see Tungsten)			Zinc difluoride (ZnF ₂)	5	1027
X-metal (see Uranium)			Zinc diiron tetraoxide (ZnFe ₂ O ₄)	5	1626
Xenon	6	57	Zinc oxide (ZnO)	5	290
Xenon tetrafluoride (XeF ₄)	5	1024	Zinc orthosilicate (see Dizinc silicon tetra- oxide)		
Ytterbia (see Ytterbium oxide)			Dizinc silicon tetraoxide (Zn ₂ SiO ₄)	5	1629
Ytterbium	4	274	Zinc sulfate heptahydrate (ZnSO ₄ ·7H ₂ O)	5	1224
Ytterbium gallate (see Triytterbium penta- gallium dodecaoxide)					

Material Name	Vol.	Page	Material Name	Vol.	Page
Zinc sulfide (ZnS)	5	714	Zirconium silicon tetraoxide (ZrSiO ₄)	5	1635
Zinc orthotitanate (see Dizinc titanium tetraoxide)			ZT-15-M	5	1285
Dizinc titanium tetraoxide (Zn ₂ TiO ₄)	5	1632			
Zircaloy 2	4	501			
Zircon (see Zirconium silicon tetraoxide)					
Zirconia (see Zirconium dioxide)					
Zirconium	4	287			
Zirconium + Hafnium + ΣX _i	4	613			
Zirconium + Indium	4	489			
Zirconium + Iron (ZrFe ₂)	4	492			
Zirconium + Iron + ΣX _i	4	610			
Zirconium + Niobium	4	495			
Zirconium + Silver	4	498			
Zirconium + Tin	4	501			
Zirconium + Titanium	4	504			
Zirconium + Uranium	4	507			
Zirconium + Uranium + ΣX _i	4	616			
Zirconium beryllide (see Zirconium 13-beryllide)					
Zirconium 13-beryllide (ZrBe ₁₃)	5	331			
Zirconium diboride (ZrB ₂)	5	391			
Zirconium carbide (ZrC)	5	478			
Zirconium tetrachloride (ZrCl ₄)	5	911			
Zirconium tetrafluoride (ZrF ₄)	5	1030			
Zirconium hydrides:					
ZrH ₂	5	1072			
ZrH _x (nonstoichiometric)	5	1069			
Zirconium dihydride (ZrH ₂)	5	1072			
Zirconium hydride, nonstoichiometric (ZrH _x)	5	1069			
Zirconium nitride (ZrN)	5	1106			
Zirconium dioxide (ZrO ₂)	5	293			
Zirconium dioxide + Titanium, cermet (ZrO ₂ + Ti)	5	1285			
Zirconium orthosilicate (see Zirconium silicon tetraoxide)					

END

DATE
FILMED

7-83

DTIC