

PHOTOGRAPH THIS SHEET

AD A951609

DTIC ACCESSION NUMBER

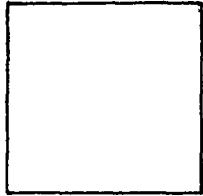

LEVEL

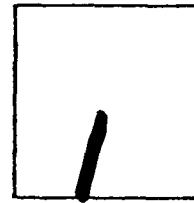

INVENTORY

NRL

* 4590

DOCUMENT IDENTIFICATION

This document has been approved for public release and sale; its distribution is unlimited.

DISTRIBUTION STATEMENT

ACCESSION FOR	
NTIS	GRA&I <input checked="" type="checkbox"/>
DTIC	TAB <input type="checkbox"/>
UNANNOUNCED	<input type="checkbox"/>
JUSTIFICATION	
BY	
DISTRIBUTION /	
AVAILABILITY CODES	
DIST	AVAIL AND/OR SPECIAL
A	

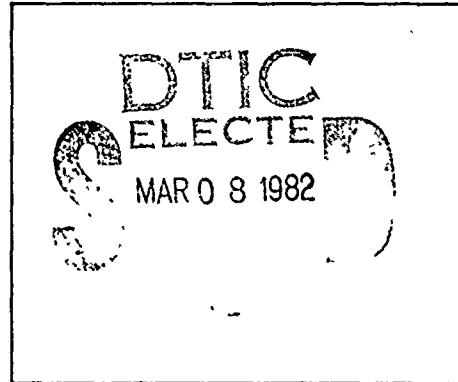

DATE ACCESSIONED

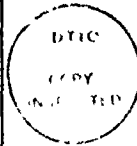

DISTRIBUTION STAMP

UNANNOUNCED

92 03 03 166

DATE RECEIVED IN DTIC

PHOTOGRAPH THIS SHEET AND RETURN TO DTIC-DDA-2

4590 UNCLASSIFIED

LMSD 86 965

copy 2 - NRL

NRL Report 4590

RD 556

C-4B

7/18/50

C-1-P

ATOMIC WEAPON DATA

SIGMA CATEGORY III

072.012,958

THE CHORD EXPERIMENT

W. B. Fussell

Radiometry I Branch
Optics Division

Repl'd 27

H791

DNA 23 Nov 58

DDC-96312

C-4B

TECHNICAL LIBRARY
JUL 27 1959
of the
DEFENSE ATOMIC
SUPPORT AGENCY

June 1955

Statement A
Approved for public release;
classification unlimited.



Classification (Cancelled) [redacted] Authority of Ltr dated 7/20/71 LASL (AEC) & [redacted] Date 8/23/71

AD A951609

NAVAL RESEARCH LABORATORY
Washington, D.C.

GOVERNMENT FURNISHED [redacted]

Atomic Energy Act of 1954

UNCLASSIFIED

TO: Chief
Administrative Services Division
Headquarters
Defense Nuclear Agency
Washington, DC 20305

REPORT LIBRARY
LOS ALAMOS SCIENTIFIC LABORATORY
P. O. BOX 1663
LOS ALAMOS, NEW MEXICO

July 20, 1971

APTL
(Ken Miller)

012958

copy was sent to you on
7-17-59.

The classification has been changed on the document(s) listed below, which our records show were sent to you. Please change the markings in accordance with AEC security regulations, as follows:

1. Place this statement on the title page:

CLASSIFICATION CHANGED TO _____
by author. , of the Atomic Energy Commission

per _____
(Authorization - see below)

by _____
(Signature of person making change. Date)

2. Line out or otherwise deface or obliterate former classification markings wherever they occur on the document.
3. Replace the former classification markings, as appropriate, with the grading authorized below, or with no markings if the document has been declassified.

Dan Baca

for the REPORT LIBRARIAN

Date: 7-20-71

DOCUMENT
NRL-4590

COPY
4B

FORMER
GRADING
Secret RD

CURRENT
GRADING
Unclassified

AUTHORIZATION
Ltr. dtd. June 1, 1971
fr. Jack H. Kahn, Chief
Declass. Br., Div. of
Classification, Wash, DC.
to L.M. Redman, IASL.

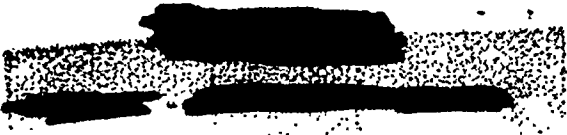

RD 556

219-ΣΣ LMSD 86965
Copy 2-1

NRL Report No. 4590, Series B.
This report consists of 24 pages.
Copy No. 4 of 15 copies.

7/18/71

ATOMIC WEAPON DATA
SIGMA CATEGORY III

OPERATION CASTLE

Project 18.6

THE CHORD EXPERIMENT

W. B. Fussell

Radiometry I Branch
Optics Division

Classification (Controlled) () UNCLAS
By Authority of LASL Ltr dated 7/20/71 (AEC)
By 2-Tory on 8/23/71

June 1955

This work was prepared as part of the optical studies conducted at CASTLE by the Naval Research Laboratory in behalf of the Los Alamos Scientific Laboratory. This is a report to LASL and further distribution of this report, or of an abstract or reproduction, may be made only with the approval of the NRL Restricted Data Control Officer.

Naval Research Laboratory
Washington 25, D. C.

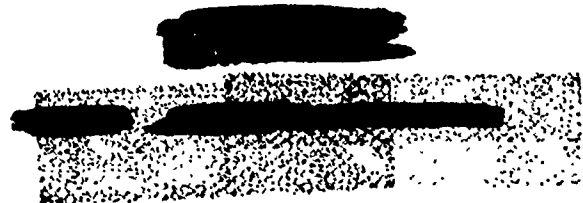

UNCLASSIFIED

[REDACTED]

ABSTRACT

The variation in the transmission of the atmosphere over an optical path passing 2900 ft from ground zero of Nectar (Mike crater) was measured as a function of time by a modified high-speed spectrograph located at Engebi in Station 1841. The spectral resolution was about 75A at 4000A and the time resolution was about 800 μ sec. The spectrograph looked with a narrow field of view at two 60-in. carbon-arc searchlights on Ruchi. The spectrograph and searchlights were timed so as to start running before zero time. In this way a reference base was obtained from which variations in the atmospheric transmission over the 3500-4500A region could be measured.

Sensitometry of the photographic data obtained reveals that, except for some Teller emission either scattered or induced in the atmosphere between the source and the spectrograph, transmission of the atmosphere in the above wavelength region started to decrease immediately after zero time, but that stable values were not reached until after about 50 msec had elapsed. These values thereafter remained essentially constant until the fireball intersected the field of view of the spectrograph at about 435 msec past zero time. The transmission declined by approximately 1.2 density units (D.U.) at 4300A. At shorter wavelengths the

[REDACTED]

effect was smaller, being approximately 1.2 D.U. at 4000A and decreasing steadily from that point to a value of about 0.2 D.U. at 3650A. There is no apparent structure in the absorption spectrum, but the resolving power of the instrument was so low that it would have been difficult for it to detect any.

The passage of the fireball between the source and the spectrograph blanked out all radiation in the 3500-4500A region quite suddenly— in less than the time resolution of the spectrograph, which was less than a millisecond. This indicates that the temperature of the fireball at this time (435 msec past zero time) was much less than that of the carbon arc source, a conclusion which agrees with other data. It also shows that the velocity of the fireball was such that it moved across the source in a time shorter than (or of the order of) the time resolution of the spectrograph. Elementary shock wave calculations roughly agree with this result.

At 4000A the amount of absorption present at 50 msec past zero time is that which would be produced by about 3.8 mm of NO_2 under standard conditions. Supporting data agree with this result, assuming that the concentration of NO_2 fell off as the inverse square of the radius from ground zero, and assuming that NO_2 is the main absorbant at 4000A.

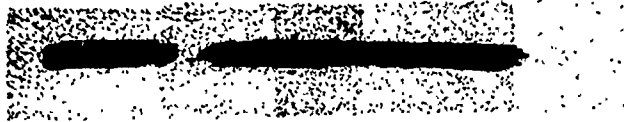

There appeared to be no correlation between intensity of Teller emission at a given wavelength and the intensity of the subsequent absorption.

The same type of experiment was attempted for Bravo, but the failure of the source just before zero time largely negated the value of the data obtained.

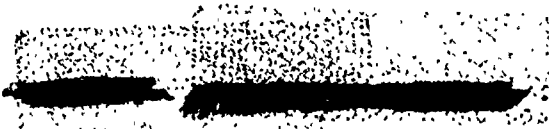

UNCLASSIFIED

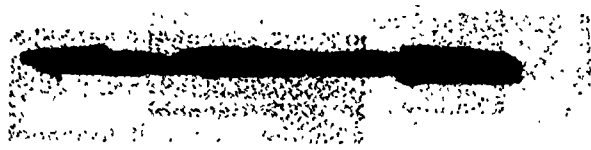

CONTENTS

ABSTRACT 2

1. OBJECTIVE 7

2. INSTRUMENTATION 7

3. RESULTS 11

4. ANALYSIS OF RESULTS 12

5. APPENDIX - DATA FROM THE 35mm MOVIE CAMERA
AIMED AT RUCHI 14

REFERENCES 16

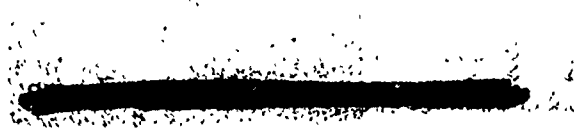

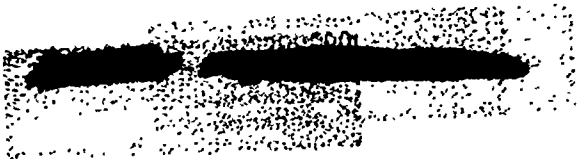

ILLUSTRATIONS

1. Schematic Drawing of the External Optics of the Spectrograph Inside Station 1841 17

2. Relative Configuration of the Source, the Spectrograph, and Ground Zero 18

3. Schematic Drawing of the External Optics Conducting Light into Station 1841 19

4. Negative Print of the Data Film, Showing Zero Time 20

5. Negative Print of the Data Film, Showing the Fireball Cutoff . . 21

6. Graph of Stable Limits of Absorption versus Wavelength 22

7. Graph of Variation of Absorption with Time at Several Wavelengths 23

8. Negative Print from the Telescopic Movie Camera 24

TABLE

1. Density Units of Absorption versus Wavelength at 60 msec Past Zero Time 10

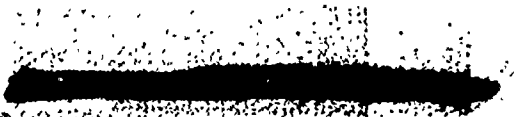

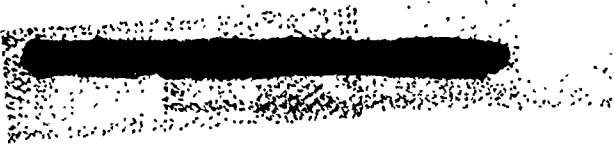

THE CHORD EXPERIMENT

1. OBJECTIVE

The immediate objective of this experiment was to measure the variation with time of the atmospheric transmission over a 22,000-ft path between Ruchi and Engebi at Eniwetok Atoll. This variation was to be measured as a function of wavelength over the region 3500-4500A immediately before and after the explosion of Nectar. The Ruchi-Engebi path was so located that the fireball of the explosion would intersect it at about the time of the minimum. It was desired to determine the effect of Nectar on the atmospheric transmission over the Ruchi-Engebi path. It was hoped that the absorption spectrum of the atmosphere over this path would indicate the varieties and concentrations of molecules formed in the excited air in front of the fireball. It was thought that the decay and formation rates of these molecules might be extracted from the data obtained by this experiment. The opacity and luminance of the fireball as functions of time and wavelength also were regarded as potentially measurable with the type of apparatus to be used.

2. INSTRUMENTATION

The spectrograph used as a detector in this experiment was a modified high-speed spectrograph. Neither the theoretical resolution

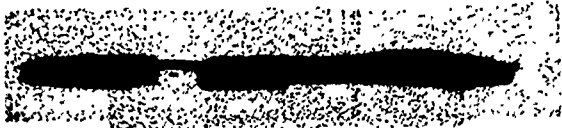

of 3.2μ at 4000A (i.e., about 0.4A, given the dispersion of 136A/mm at 4000A) nor the graininess of the film used (70-mm Eastman Kodak Tri-X AR) was the limiting factor in this instrument; the spectral resolution was limited by the size of the slit. It was necessary to use a large slit ($1/2$ mm square) because previous trials at NRL had indicated that useful densities in the spectral region of interest (3500-4500A) could not be obtained otherwise by using the source available for this experiment—a 60-in. carbon-arc searchlight. The $1/2$ -mm-square slit gave a resolution of about 70A at 4000A. The spectrograph was an $f/6.5$ instrument operated as a "strip" machine—that is, the image did not move with the film in discrete jumps as in the "framing" high-speed spectrographs, but the film acted as its own shutter by moving with respect to a stationary spectrum. Two other respects in which this instrument differed from the prototype (described in J. Opt. Soc. Am.¹) were the timing system and the film drive mechanism. Normally, a film speed of either 10 ft/sec or 60 ft/sec is used, but these speeds would not have given sufficient densities for this experiment. Instead, a motor and a three-speed gear box were used to give film speeds of 3.3, 1.1, and 0.28 ft/sec. These speeds were available with the large, standard size, takeup spool in place. A film takeup spool of smaller radius was available, which

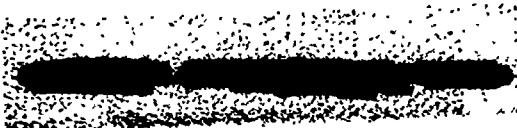

reduced these speeds by about half. It was found desirable to use as high a film speed as possible to minimize fluctuations in the film speed. For the Nectar shot a film speed of about 1.8 ft/sec was used. This gave a time resolution of about 800 μ sec.

Due to the slow film speed, the normal 1000-cycle timing system could not be used. Instead, 120-v 60-cycle ac was applied directly to the timing light through a current-limiting resistor of about 15,000 ohms.

The spectrograph was located in Station 1841 on Engebi. A 10-ft focal length, front surface parabola, about 16 in. in diameter, was used to form an image of the source on the slit of the spectrograph. To enable the parabola to operate on axis, thus eliminating coma, a Newtonian system was used with a 3-in.-square optical flat deflecting the converging light from the parabola onto the slit (see Fig. 1). As it turned out, it was difficult to maintain alignment of the small image of the searchlight on the slit of the spectrograph, so this image was defocussed to a diameter of about 3.5 mm. (The calculated geometrical size of the image was about 0.7 mm.) This gave a field of view of about 25 ft at Ruchi where the searchlight was located, the distance between Ruchi and Engebi being about 22,000 ft (Fig. 2). Light from the source on Ruchi was directed into Station 1841 by an 18-in.-square front surface mirror placed about 40 ft away from the entrance to Station 1841

[REDACTED]

(Fig. 3). A 7-in.-square Vicor-glass aperture in the door of Station 1841 permitted the light to enter and illuminate the parabola described above.

Since the results of the first Chord experiment seemed to indicate that the searchlight had failed to function properly, two 60-in. carbon-arc searchlights were used for Nectar. They were placed practically adjacent to each other on Ruchi and well within the 25-ft field of view (at that distance) of the spectrograph.

The results of the Chord experiment was displayed in Figs. 4 and 5. A graphical analysis of the results is given in Figs. 6 and 7. Table a tabulation of the data in Fig. 6, is self explanatory.

Table 1 - STABLE LIMITS OF ABSORPTION IN THE 3500-4500A RANGE

Wavelength, 10^3A	Stable absorption limit, D.U. ^a
4.30	1.25
4.14	1.23
4.00	1.22
3.88	0.96
3.76	0.60
3.64	0.23

^aThe number of D.U. (density units) is equal to the quantity $\log I_0/I$, where I_0 is the reference intensity and I is the intensity after absorption has taken place.



3. RESULTS

In Fig. 7, density units of absorption are plotted as ordinate versus time past zero time in milliseconds as abscissa. The variation in photographic gamma over the wavelength interval was taken into account. These figures were obtained by sensitometering the data film in the vicinity of zero time. From the densitometer traces, the average photographic density of the carbon-arc spectrum was found at each wavelength of interest during the period immediately before zero time. This was then used as a reference base from which to measure changes in photographic density after zero time. Smoothed curves were then drawn through the portions of the densitometer traces occurring after zero time. The data points in Fig 7 were computed from these smoothed curves. The values of photographic gamma used in calculating these points were obtained from a set of H and D curves for the same emulsion, processed in the same manner.

In Fig. 6, the stable limit of absorption at each of the wavelengths measured is presented as ordinate in density units versus the wavelength in Angstroms as abscissa. The values of the absorption at 60 msec past zero time were used as the stable limits, as the absorption changed very little after that time.



4. ANALYSIS OF RESULTS

The radiation emanating from a gas layer interposed between a source and a receiver is given by the equation

$$I = I_0 T + E_{bb}A, \quad (1)$$

where

I = intensity at the receiver,

I_0 = intensity of the source,

T = transmission of the gas layer,

A = absorption of the gas layer ($A = T - 1$), and

E_{bb} = the emissivity of a black body at the temperature of gas layer, all quantities being measured at the wavelength under consideration. This means that to definitely establish the temperature and absorptivity of a gas layer, two measurements of the received intensity under different conditions of illumination must be made (i.e., two different values of I_0). Thus the Chord experiment as operated at Nectar cannot give exact values of absorption if the temperature of the gas layer is not known. It has been assumed, however, that the temperature of the gas layer is low. Therefore, if the absorption A is not too high, Eq. 1 is approximately

$$I = I_0 T. \quad (2)$$

On the other hand, it was concluded from the data that the fireball absorption was high. This is evidenced by the abrupt "chop-off" of light

[REDACTED]

from the searchlight immediately after the fireball crosses the field of view of the spectrograph.

Looking at Fig. 7, one sees that the absorption becomes evident immediately after zero time except where Teller emission masks this effect during the first few milliseconds. At about 50 msec past zero time the absorption at all wavelengths has reached a stable value. This stable limit increases steadily with increasing wavelength between 3600-4300A.

Referring to Fig. 6, it is seen that there is not a particularly close correlation between the absorption curve plotted there and the comparison curve which gives the absorption coefficients of NO_2 under standard conditions.² It is interesting to note, however, that the value of the absorption measured by the Chord experiment at 4000A and 50 msec is that which would result from 3.8 mm of NO_2 under standard conditions. On the other hand, a calculation of the amount of NO_2 lying between Ruchi and Engebi, using spectra taken with another high-speed spectrograph of much higher spectral resolution and assuming that the concentration of NO_2 falls off as the inverse square of the distance from ground zero, arrives at nearly the same figure for the total amount of NO_2 — 3.7 mm. Thus it seems reasonable to assume that the significant factor causing the absorption found in

[REDACTED]

the Chord data is NO_2 , at least at 4000A which is the peak of the absorption spectrum of NO_2 under standard conditions.

The complete cutoff of radiation in the 3500-4500A region after the fireball crossed the Ruchi-Engebi path can be explained by calculating the spectral emissivity of a black body at 4000°K (approximately equivalent to the carbon-arc source) at 4000A and comparing this figure with the emissivity of a black body at 2000°K at the same wavelength. (Supporting data indicates that the temperature of the fireball when it crossed the Ruchi-Engebi path was about 2000°K .) It is found that the ratio of the emissivities is about 7400, which is sufficient to drop the intensity to below the limit of detectability with the instrument used, even though (since the searchlight image was defocussed) the fireball was favored by a factor of at least 10 when it filled the field of the spectrograph.

APPENDIX

A 35-mm movie camera equipped with a telephoto lens was aimed at the 60-in. searchlights on Ruchi. The camera itself was in Station 1841 on Engebi and operated at 24 frames per second. As can be seen from Fig. 8, the film from this camera shows that the searchlights started successfully before zero time and remained on at least until the fireball of Nectar blocked the path between Station 1841 and Ruchi.

[REDACTED]

Before Nectar went off, the transmission over the Engebi-Ruchi path was about 59 percent, the attenuation coefficient being about 0.13 mi^{-1} . These figures apply to the visible region in the neighborhood of 5500A. At 200 msec after zero time, the attenuation coefficient appears to have risen to approximately 0.16^{-1} . This figure was obtained by sensitometry of the data film; specifically, the brightness of the air-scattered light from the fireball was compared with the brightness of the beach at Ruchi, which was illuminated by the fireball. From the ratio of the two brightnesses the scattering component of the attenuation coefficient could be calculated, given the reflectivity of the Ruchi beach (assumed to be 80 percent) and the total attenuation coefficient. It was assumed that the sole addition to the attenuation coefficient after zero time was due to an increase in the scattering component of this coefficient. Since the previous portion of this report shows that the absorptive component of the attenuation coefficient may be due to NO_2 , and since the absorption of NO_2 above 5000A is quite low, the above assumption seems reasonable. This is further supported by the marked increase in aureole around the searchlights on Ruchi after zero time.

[REDACTED]

REFERENCES

1. D. J. Lovell, H. S. Stewart, and Seymour Rosin, "Cine Spectrograph," J. Opt. Soc. Am. 44:799 (1954).
2. T. C. Hall, Jr., and F. E. Blacet, "Separation of the Absorption Spectra of NO_2 and N_2O_4 in the Range 2400-5000A," J. Chem. Phys. 20:1745 (1952).

UNCLASSIFIED

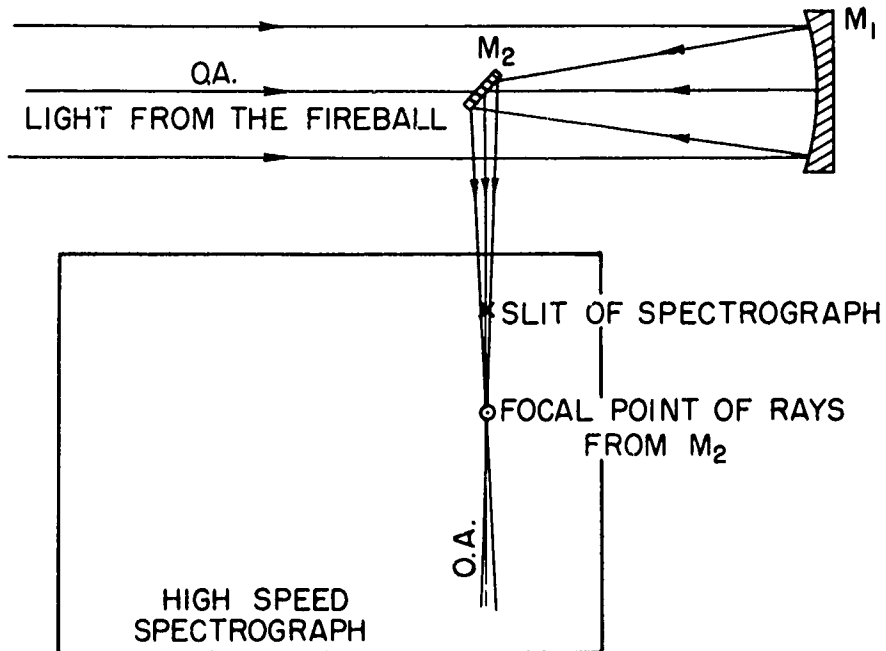

- M₁ - PARABOLIC CONCAVE MIRROR
- M₂ - 3 IN. SQUARE, OPTICALLY FLAT MIRROR
- O.A. - OPTICAL AXIS OF SPECTROGRAPH

Fig. 1 - Schematic Drawing of the External Optics of the Spectrograph Inside Station 1841

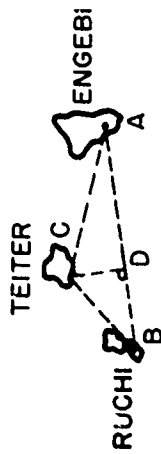

AB - 22,000 FT
 BC - 6,700 FT
 CA - 16,200 FT
 CD - 2,900 FT
 \angle DCA - 79° 30 MIN
 \angle BCD - 64° 10 MIN

ENIWETOK ATOLL

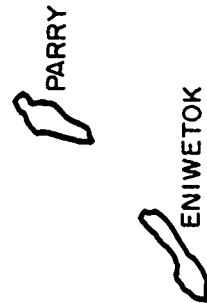

A - STA. 6A, ENGEBI, LOCATION OF SPECTROGRAPH.
 B - 60 IN. SEARCHLIGHT ON RUCHI
 C - GROUND ZERO FOR NECTAR

Fig. 2 - Relative Configuration of the Source, the Spectrograph, and Ground Zero

NOTE: THIS DRAWING IS
NOT TO SCALE

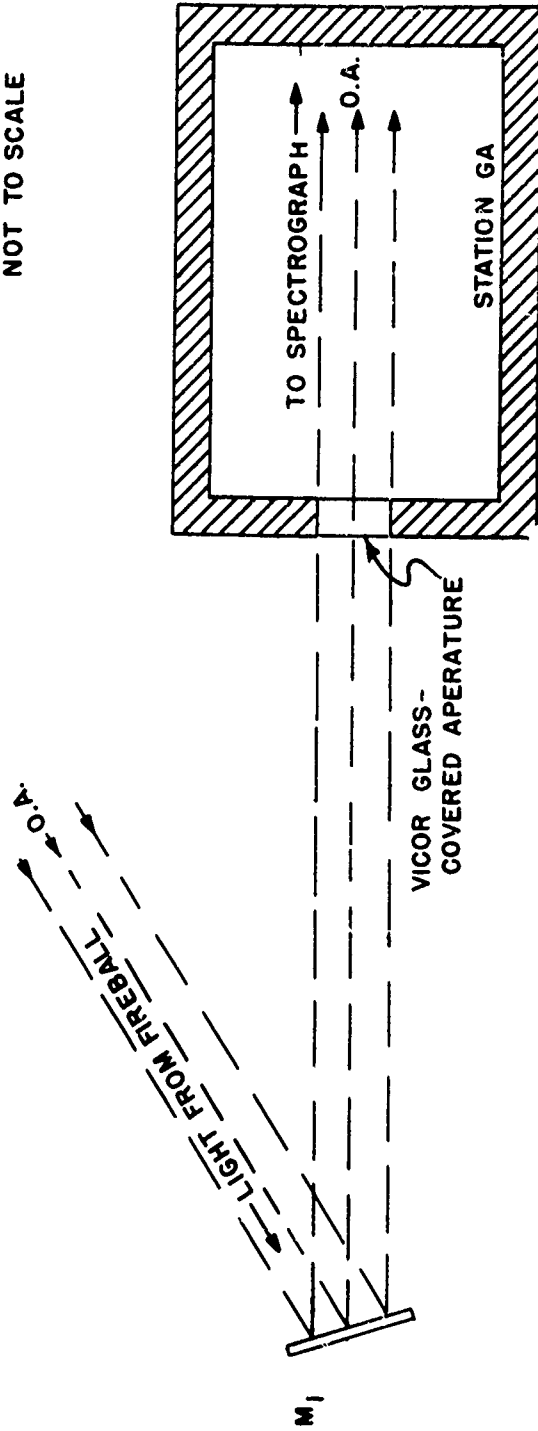

O.A.-OPTICAL AXIS

M₁ -FRONT SURFACE FLAT MIRROR

Fig. 3 - Schematic Drawing of the External Optics Conducting Light into Station 1841

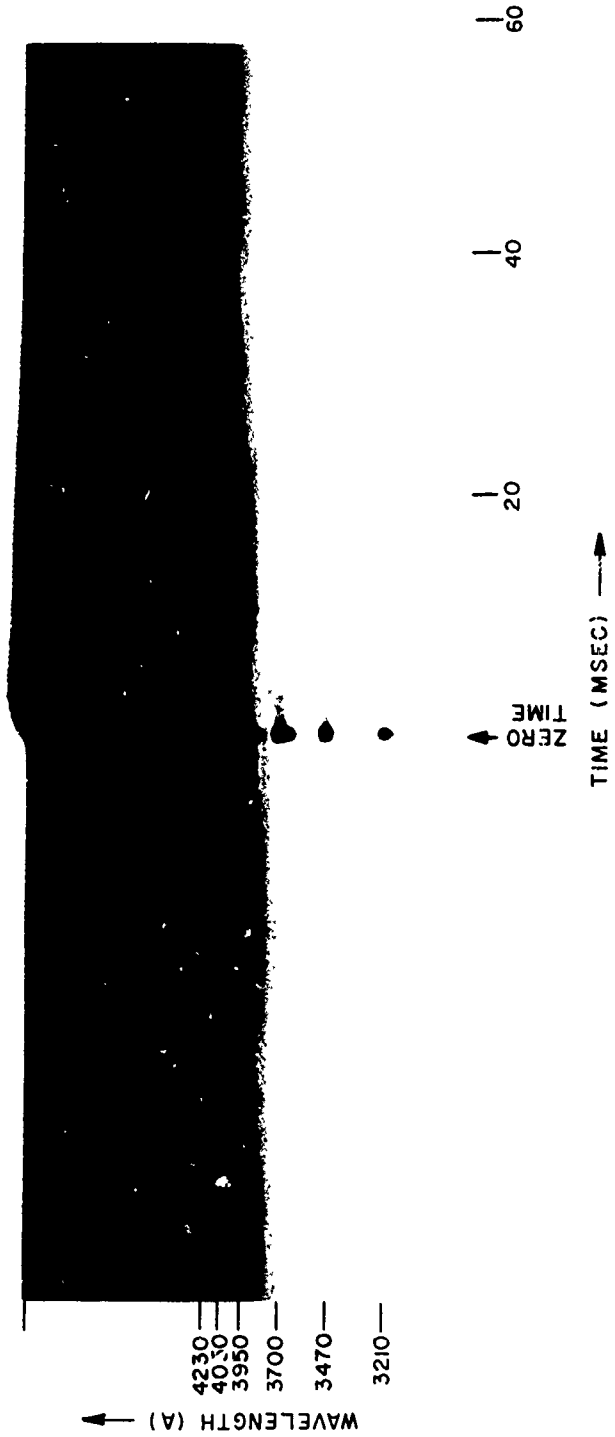
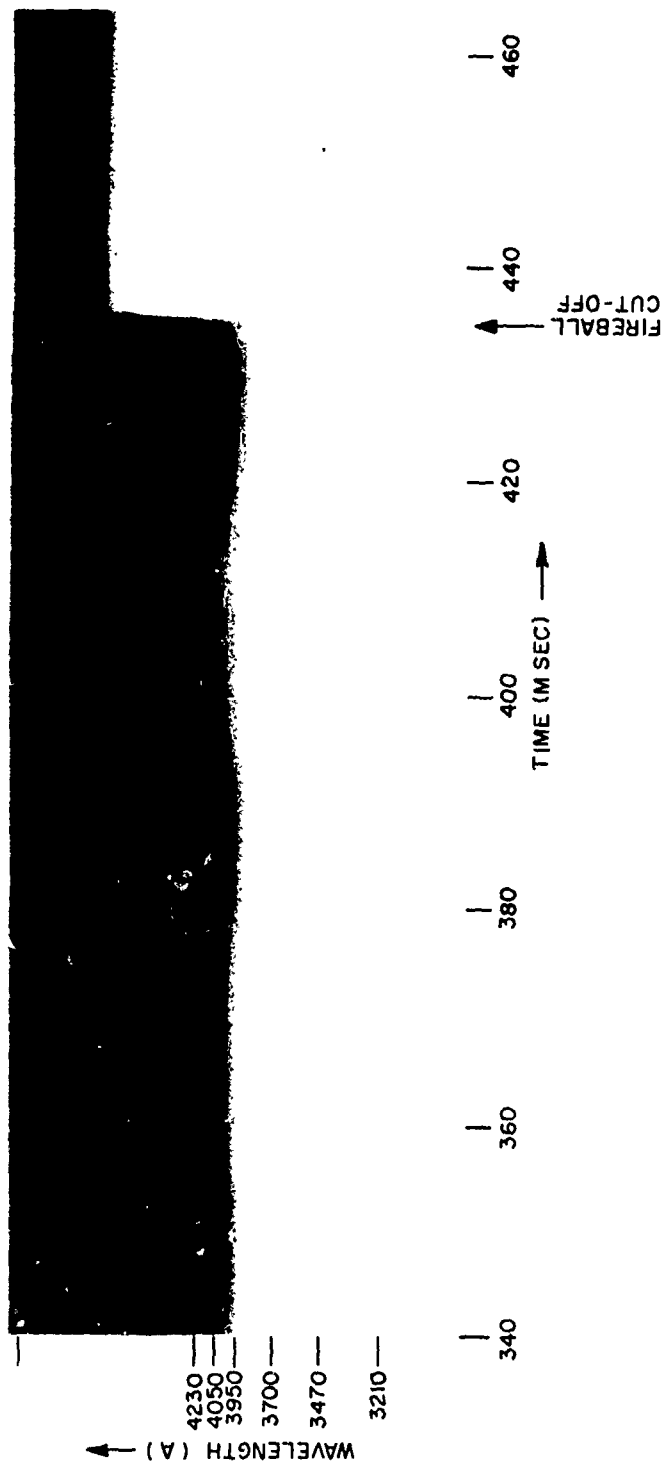

Fig. 4 - Negative Print of the Data Film, Showing Zero Time

UNCLASSIFIED



21

Fig. 5 - Negative Print of the Data Film, Showing the Fireball Cutoff

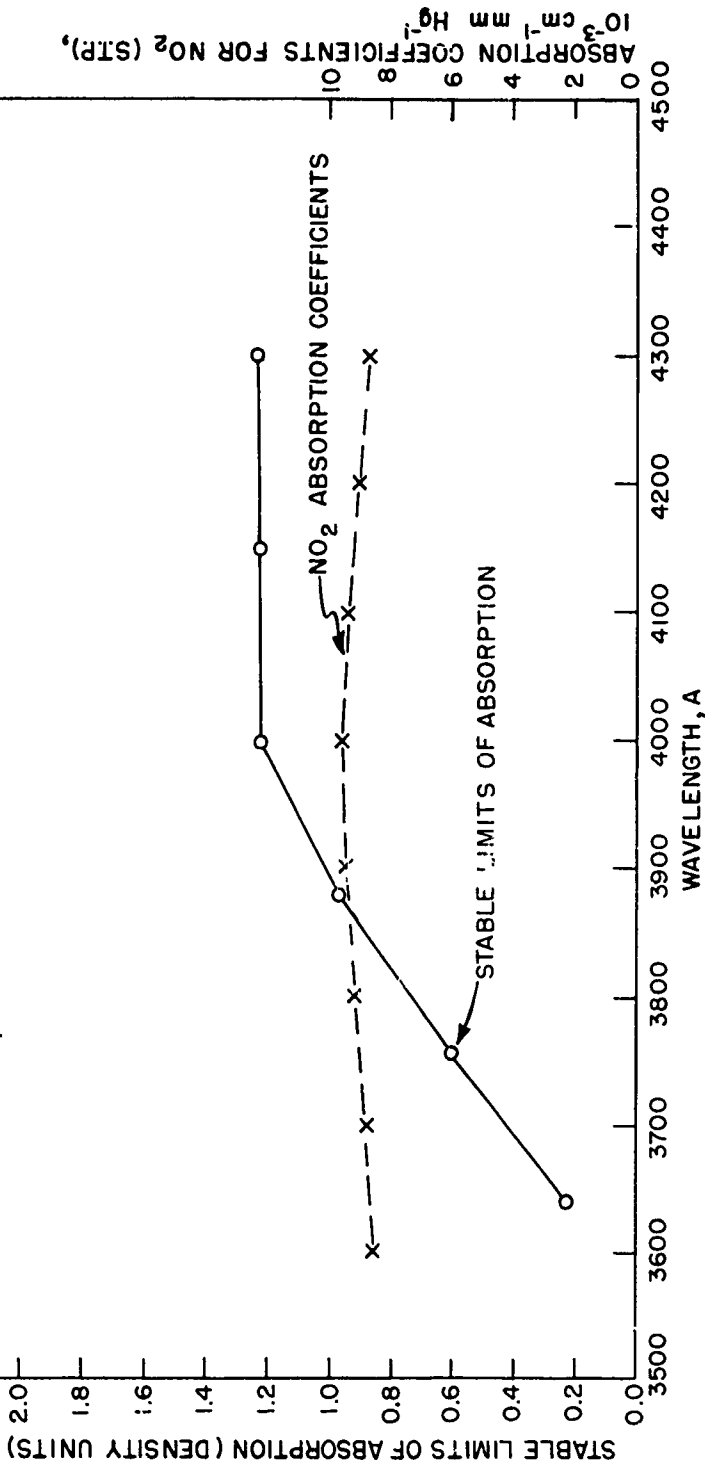
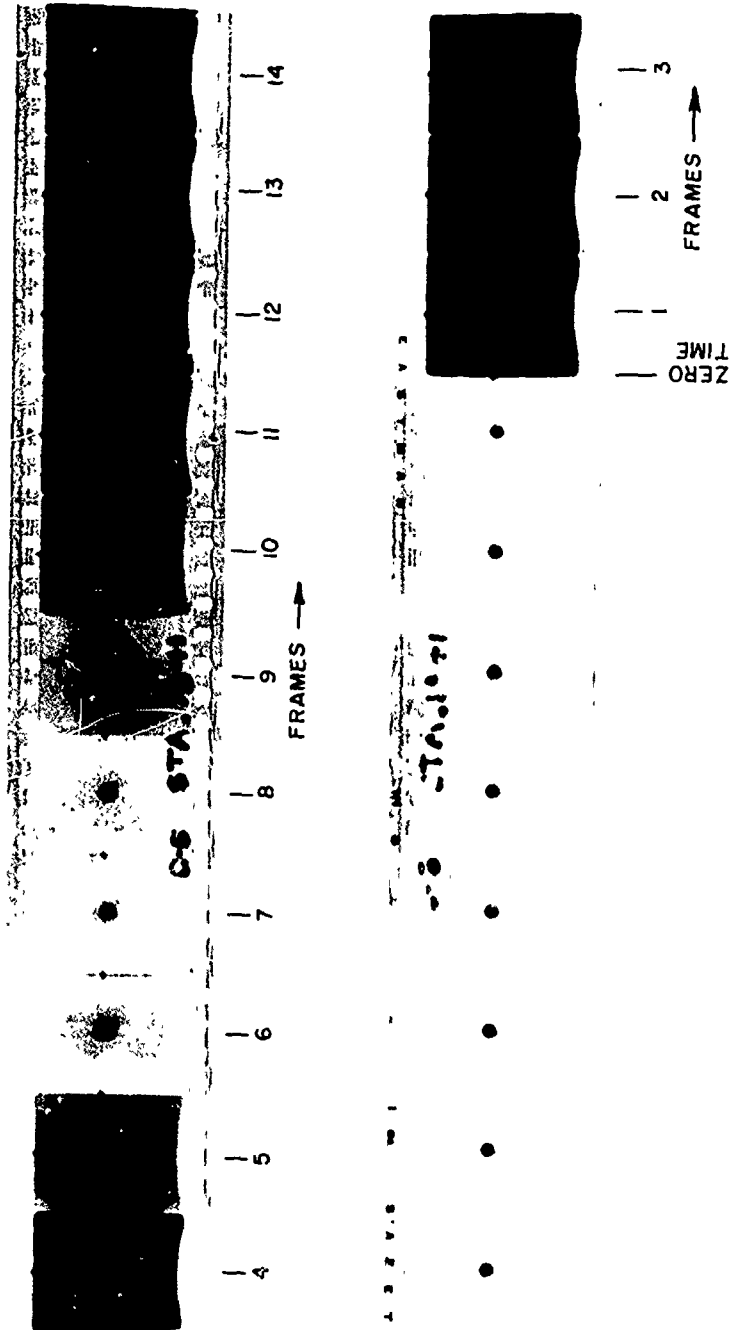

Fig. 6 - Graph of Stable Limits of Absorption versus Wavelength

**THIS
PAGE
IS
MISSING
IN
ORIGINAL
DOCUMENT**



(NOTE: EACH FRAME IS 1/24 SEC)

Fig. 8 - Negative Print from the Telescopic Movie Camera