

ARR April 42

L-263

NATIONAL ADVISORY COMMITTEE FOR AERONAUTICS

WARTIME REPORT

ORIGINALLY ISSUED

April 1942 as
Advance Restricted Report

EFFECT OF SPRING AND GRAVITY MOMENTS IN THE
CONTROL SYSTEM ON THE LONGITUDINAL STABILITY
OF THE BREWSTER XSBA-1 AIRPLANE

By William H. Phillips

Langley Memorial Aeronautical Laboratory
Langley Field, Va.

PROPERTY OF JET PROPULSION LABORATORY LIBRARY
CALIFORNIA INSTITUTE OF TECHNOLOGY



WASHINGTON

NACA WARTIME REPORTS are reprints of papers originally issued to provide rapid distribution of advance research results to an authorized group requiring them for the war effort. They were previously held under a security status but are now unclassified. Some of these reports were not technically edited. All have been reproduced without change in order to expedite general distribution.

NATIONAL ADVISORY COMMITTEE FOR AERONAUTICS

ADVANCE RESTRICTED REPORT

EFFECT OF SPRING AND GRAVITY MOMENTS IN THE CONTROL

SYSTEM ON THE LONGITUDINAL STABILITY

OF THE BREWSTER XSBA-1 AIRPLANE

By William H. Phillips

SUMMARY

Calculations have been made to determine the effects of spring and gravity moments in the control system on the longitudinal-stability characteristics of the Brewster XSBA-1 airplane, and the computed results have been verified by flight tests.

It has been found that the type of stick-force variation with airspeed in a given flight condition may be changed within wide limits by use of weight or spring moments in the control system and that the stick forces required in maneuvers may be reduced by the use of weight moments. By the use of weight and spring moments in combination, both of these factors may be adjusted independently. Flight tests on the Brewster XSBA-1 airplane showed, however, that the maneuvering forces could not be reduced below a certain point without encountering an unstable condition in which the airplane diverged from straight flight into a dive with controls free.

The use of a weight moment large enough to increase appreciably the moment of inertia of a control system was considered by the pilot to be undesirable.

INTRODUCTION

At the request of the Bureau of Aeronautics, Navy Department, an investigation has been made by the NACA at the Langley Memorial Aeronautical Laboratory to determine theoretically the effects of spring and gravity moments, used singly or in combination, on longitudinal-stability characteristics of the Brewster XSBA-1 airplane and to correlate the theoretical results with the results of flight measurements.

CALCULATED EFFECTS OF SPRING AND GRAVITY MOMENTS

The longitudinal stability of an airplane under varying conditions of power cannot be computed accurately but must be determined experimentally. If the stability characteristics are known, however, the changes caused by the addition of spring or weight moments to the control system can be readily calculated.

It is necessary to know the variation of elevator angle, elevator force, inclination of the thrust axis, and force per degree trim-tab change with airspeed. From these characteristics, the variation of stick force with airspeed that will occur with any arrangement of weight and spring moments in the system may be found. It is necessary only to calculate the force increment contributed by weight or spring at corresponding values of elevator angle and attitude of the thrust axis and to add this increment to the original value of force for the same conditions of speed, power, and trim-tab setting. A new curve of stick force against airspeed can then be plotted for the modified control system. The variation of stick force with airspeed for any other trim-tab setting may be obtained by adding to the values obtained from this modified force curve the stick force caused by the change in trim-tab setting. The following special cases are of interest.

Spring giving constant hinge moment.— A spring giving approximately constant hinge moment may be attached to some part of the control system. If linear change of tail-lift coefficient with hinge-moment coefficient is assumed, a constant amount of lift will be added to the force on the tail at any airspeed, thus giving a fixed moment about the center of gravity. The effect of this moment on the forces required for trim of the airplane will be about the same as the effect if the center of gravity of the airplane were shifted by a weight giving the same moment. The variation of stick force with speed in steady flight is therefore affected by a constant-tension spring in the same way that it is affected by a shift in the center-of-gravity position. A spring tending to depress the elevator causes an increase in the slope of the curve of stick force against airspeed as does a more forward location of the center of gravity.

In cases in which the variation of elevator-lift

L-263

coefficient with hinge-moment coefficient is nonlinear, the use of a constant-tension spring will not, of course, have exactly the same effect as a shift of the center of gravity.

The use of a constant-moment spring does not affect the characteristics of the airplane in accelerated maneuvers, because the force that it applies to the control system is unaffected by normal acceleration. If, therefore, an airplane had satisfactory characteristics in maneuvers but had an unstable variation of stick force with speed in steady flight, its stability characteristics could be improved by the use of a constant-moment spring tending to depress the elevator.

Constant weight moment.— A constant weight moment on the control system may be approximated by attaching a weight to the elevator or to an arm extending horizontally ahead of or behind some hinge line in the system. Actually, the weight moment can never be exactly constant because the moment arm changes slightly with elevator angle and inclination of the airplane. The effect of this moment on the stick forces in steady flight will be similar to the effect of the constant-tension spring discussed previously.

In maneuvers, however, the weight moment is changed by the acceleration of the airplane. If linear hinge-moment characteristics of the elevator are assumed, it may be shown that the stick force required to make a highly accelerated maneuver in an airplane increases linearly with the normal acceleration and that the force per g acceleration is independent of the speed, provided the airplane is trimmed for steady flight at the speed at which the maneuver is made. Likewise, the moment exerted by a weight attached to the system varies linearly with the normal acceleration. A weight moment that tends to raise the elevators may therefore be used to lighten the maneuvering forces.

The elevator-force characteristics of the airplane may be seen to be affected by the use of a weight moment in the same way as by a change in center-of-gravity location, both in steady flight and in accelerated maneuvers. The effect of a weight moment differs from the effect of a center-of-gravity change only in unsteady flight conditions, in which the moment of inertia of the elevator system causes a lag in the motion of the control.

Combination weight and spring.— If a weight moment applied to lighten the elevator force is offset by a spring exerting an opposite moment of equal magnitude, the net moment acting on the elevator in straight flight will be the same as if no weight and spring were present. In maneuvers, however, the effect of the weight moment will be proportional to the normal acceleration; whereas the spring moment will remain constant. This condition suggests the possibility of combining spring and weight moments to reduce maneuvering forces without altering the static stability.

It is obvious that many more arrangements of weights and springs may be used to obtain some desired effect in any particular case. For example, the use of a weight below the hinge line of the control stick may be effective in increasing the stability of the airplane in the climbing conditions of flight but will not affect the stability with power off. This type of weight moment may also affect the aileron forces when the airplane is subjected to lateral or rolling accelerations. Any general conclusions regarding arrangements of this kind cannot be made, however, because their effects depend on the characteristics of the airplane on which they are used.

Although any desired variation of stick force with airspeed may be obtained by use of the correct weight and spring combination, it must be remembered that a stable variation of stick force with airspeed is not the only requirement for satisfactory handling characteristics of an airplane. Provision for a definitely stable variation of elevator angle with airspeed has been found necessary in order that the pilot may make rapidly accelerated turns without stalling or reaching excessive accelerations. The variation of elevator angle with airspeed is not affected by adding weight or spring moments to the control system but must be adjusted by using the correct center-of-gravity location and sufficiently large tail surfaces.

TEST RESULTS AND DISCUSSION

In order to verify the calculated effects of weight and spring moments, flight tests were made on the Brewster XSBA-1 airplane (figs. 1, 2, 3, 4). A description of the airplane is given in the appendix. The variation of elevator angle with position of the top of the control stick is shown in figure 5. In order to obtain the desired in-

formation, simultaneous measurements were made of the air-speed, elevator force, elevator angle, and linear accelerations. The control-position recorder was attached to the control cables near the rear cockpit, but the measurements were corrected for cable stretch to give the true elevator angles.

Measurements of the longitudinal stability of the Brewster XSBA-1 airplane were made with the combinations of spring and weight moments shown in figure 6 for the following conditions of flight:

Condition	Manifold pressure (in. Hg)	Altitude (ft)	Engine speed (rpm)	Flap	Gear
Gliding	Throttle closed	-----	-----	Up	Up
Cruising	25	6000	1800	Up	Up
Climbing	32	6000	1800	Up	Up

Figures 7, 8, and 9 show the variation of elevator angle, elevator force, and inclination of the thrust axis with indicated airspeed for the original airplane in the three conditions of flight listed. Figure 10 shows the experimentally determined change in stick force per degree change in elevator trim-tab angle for the same conditions.

These curves were used as a basis for calculating the stick-force variation with airspeed for the various arrangements of springs and weights that were tried. Because the airplane had a high degree of static stability in each of these conditions, it was considered unnecessary to use any arrangement that would increase the stability. Instead, provision was made for attaching a weight that tended to raise the elevator. This weight was expected to reduce the stability of the stick-force variation with airspeed and to have the desirable effect of reducing the maneuvering forces. Figure 6 shows how the weight was attached to the control-stick socket in the rear cockpit. Four series of runs were made, three with the weight in different positions to provide different weight moments and the fourth with the maximum weight moment exactly offset by a spring. The magnitude of the weight moments as measured by the stick force required to balance them is given in figure 6.

Figures 7 to 9 and 11 to 16 show the calculated and experimentally determined stick-force curves for the three sets of runs in which the weight moment alone was used, and figures 17 to 19 show these curves for the weight and spring combination. In each figure, a curve showing the variation of stick force with airspeed for the original airplane trimmed at the same speed is included for comparison.

The accuracy of the experimental force curves is limited by the friction in the elevator system, which amounts to ± 3 pounds. The trim-tab settings shown by the indicator in the cockpit may be in error by $\pm 1^\circ$ because of backlash in the tab system. The experimental and the computed force curves are seen to be in agreement within these limits of accuracy, with the exception that two of the runs in the gliding condition show larger discrepancies. The reason for these differences is not known, but the measurements appear to be in error for these particular tests.

In order to determine the reduction of stick force in maneuvers caused by the weight moments, records were taken of rapid 180° turns at various speeds. Elevator force and normal acceleration were read from the records at representative points. Curves of force against normal acceleration are shown in figure 20 for the original airplane and for three of the weight arrangements.

There is considerable scatter in the measurements because, as the stall is approached, the stick force increases rapidly both in turns and in normal flight. This tendency is shown in all the static stability measurements (figs. 7 to 9 and 11 to 19) and is ascribed to separation of the flow at the wing root at high lift coefficients. This flow separation decreases the downwash at the tail and necessitates the use of large upward deflection of the elevator. Even below the stall the stick force is probably increased at high elevator angles because of nonlinear hinge-moment characteristics of the elevator. Turns made at high lift coefficients will therefore require a greater force per g than those made at low lift coefficients.

The scatter of the experimental points makes it impossible to assign a definite shape to the curve of stick-force variation with normal acceleration. Theoretically, this curve should start from an elevator force of zero at $1 g$ and should approach asymptotically a straight line through the origin at high accelerations. Only this

straight line has been drawn in the figure. The slope of this line shows the force per g acceleration required in maneuvers.

The original airplane required a force of about 23 pounds per g . The weight moment of case 1, which gave a force of 7 pounds on the stick, reduced the maneuvering forces to about 19 pounds per g , and that of case 3, which gave 14.5 pounds on the stick, reduced them to about 13 pounds per g . The reduction is not quite so great as would be predicted by simply subtracting the static weight moment from the original 23 pounds per g because the pilot more frequently made turns at high lift coefficients in the region of increased maneuvering forces when the stick forces required to reach these lift coefficients were reduced.

The fourth arrangement, consisting of the maximum weight moment offset by a spring, gave the same maneuvering forces as the maximum weight moment without the spring. This similarity would be expected because the spring has no additional effect in accelerated maneuvers.

The experimental results all indicate essential agreement with the predicted results. Several characteristics of the airplane were noticed in the course of the tests, however, that affect its handling characteristics but that are not apparent from measurements of static stability or steady turns. In the first place, the pilot regarded the large inertia of the control system, when fitted with weights, as definitely undesirable because the control stick was difficult to move rapidly and because it tended to overshoot when suddenly deflected.

Another undesirable characteristic noted by the pilot was a rapid divergence into the path of an outside loop when the stick was pushed forward gently and released. This divergence occurred with the maximum weight moment, either with or without the springs. In order to study this type of divergence, records were taken of longitudinal oscillations started by increasing the speed 15 miles per hour and releasing the stick. Figure 21 shows a time history of such an oscillation. The amplitude of the oscillation is seen to increase slowly for several cycles. Then, when a certain acceleration has been reached, the weight moment causes the stick to move forward, putting the airplane into a diving attitude.

Such a divergence might be caused by a condition of

static instability: that is, a positive slope of the curve of stick force against airspeed. The curves of figure 17, however, show that the stick-force slope for this condition is definitely stable. The only other way that this divergence can occur is to have the weight moment on the elevator greater than the moment required per g normal acceleration in accelerated maneuvers. Because in accelerated turns it was found that the weight moment was only sufficient to reduce the stick force from 23 to 13 pounds per g , it at first appears that no divergence should occur. About 5 pounds less force was required, however, per g normal acceleration in push-downs than in pull-ups for this airplane. This effect would increase the likelihood that the weight moment would be sufficient to cause a diving divergence. Also, it must be remembered that the turns were all made at high lift coefficients in the range where the elevator force is increased because of large elevator deflections. Probably the force per g in more gentle maneuvers at low lift coefficients would be smaller. The divergence does not occur before a normal acceleration of about $0.5 g$ has been reached. The friction in the elevator system is believed to prevent much motion of the elevator until this value of acceleration has been exceeded.

The long-period, or phugoid, oscillation of the airplane with the weight moment will be noted to increase slowly with time. On the original airplane the oscillations decreased slowly with time. In general, it is believed that weight moments tending to raise the elevator will tend to decrease the stability of the phugoid oscillation. This tendency, however, is not regarded as serious because the handling qualities of an airplane are not critically affected by the characteristics of its long-period oscillation.

Too large a weight moment tending to depress the elevator may cause undamped short-period oscillations.

This type of instability is discussed in reference 1.

Spring moments, however, should have no effect on the short-period oscillation characteristics because the stick force that the springs exert does not depend on the acceleration of the airplane.

CONCLUSIONS

1. The calculated effects of spring and weight moments on longitudinal stability agreed with the results of flight measurements within the experimental error.

L-263

2. Weight moments applied to the elevator control system may be used to adjust the slope of the curve of stick force against airspeed and also to change the maneuvering forces within wide limits. Spring moments, however, change only the stick-force variation in steady flight. By the use of weight and spring moments in combination, these factors may be independently varied.

3. A weight moment is undesirable if it increases the inertia of the control system to a point where considerable effort is required on the part of the pilot to make rapid movements of the control stick.

4. Too large a weight moment tending to depress the elevator will cause unstable, short-period longitudinal oscillations. A weight moment in the direction that raises the elevator will decrease the stability of the long-period, or phugoid, oscillation. This tendency is not regarded as serious, however.

5. If the weight moment tending to raise the elevator exceeds the moment required per g normal acceleration in maneuvers, the airplane will perform a rapid divergence with the controls released. Because of nonlinear hinge-moment characteristics of the elevator, this divergence may occur from straight flight even though at the high elevator angles required in accelerated turns the weight moment is not great enough to reduce the maneuvering forces to zero.

6. Spring moments are not expected to have any effect on the short-period oscillation characteristics of the airplane.

Langley Memorial Aeronautical Laboratory,
National Advisory Committee for Aeronautics,
Langley Field, Va.

APPENDIX

DESCRIPTION OF THE BREWSTER XSBA-1 AIRPLANE

The XSBA-1 airplane is a two-place, single-engine, midwing, cantilever monoplane with retractable landing gear. For the investigations described in this report, the cut-outs in the flap were sealed to give a conventional partial-span split flap (figs. 1, 2, 3, 4). The general specifications of the airplane follow:

Name and type Brewster XSBA-1

Engine Wright Cyclone R-1820-38

Rating:

Take-off 950 hp at 2200 rpm and 41.0 in. Hg manifold pressure

Maximum continuous (sea-level) 850 hp at 2100 rpm and 35.7 in. Hg manifold pressure

Cruising 600 hp at 1900 rpm and 30 in. Hg manifold pressure

Gear ratio (ungeared) 1:1

Propeller Hamilton-Standard constant speed

Diameter 9 ft

Number of blades 3

Fuel capacity 136 gal

Oil capacity 10 gal

Weight (empty) 3620 lb

Normal gross weight (Scout) 5276 lb

Wing loading (normal gross weight) 20.4 lb/sq ft

L-209

Power loading (normal gross weight) 6.6 lb/hp
 Over-all height (thrust-axis level) 12 ft 2³/₄ in.
 Over-all height (3-point position, to
 propeller tips) 9 ft 3 in.
 Over-all length 27 ft 11¹/₂ in.

Wing:

Span 39 ft 0 in.
 Area (including ailerons and fuselage) 29¹/₂ sq ft
 258 sq ft
 Airfoil section NACA CYH tapered 18 percent
 to 11.8 percent thick
 Aspect ratio 5.9
 Mean aerodynamic chord 83.3 in.
 Distance behind leading edge of wing at root 2.39 in.
 Taper ratio 1.5:1
 Dihedral, leading edge of center section to
 leading edge of outer panel 4.5°
 Incidence 10°
 Sweepback (leading edge of wing) 1.6°

Wing flaps:

Area 20.4 sq ft
 Maximum deflection 67°

Ailerons:

Length 7 ft 2 in.
 Area, behind hinge line (each) 9.7 sq ft
 Trim-tab area, behind hinge line (each) 0.63 sq ft

Fin area (above fuselage, ahead of hinge line,
not including balance area) 12.1 sq ft

Rudder:

Vertical span (from center line of
fuselage) 6 ft $6\frac{3}{4}$ in.

Area (behind hinge line and including horn-
balance area) 13.9 sq ft

Horn-balance area 1.5 sq ft

Trim-tab area None

Stabilizer area (ahead of hinge line, not
including horn-balance area but including
contained fuselage area) 30.6 sq ft

Elevator:

Span 14 ft 10 in.

Area (behind hinge line, including horn-
balance area) 30.6 sq ft

Trim-tab area 1.7 sq ft

Distance from elevator and rudder hinge lines
to leading edge of wing 18 ft $11\frac{1}{2}$ in.

Maximum fuselage cross-sectional area
(at cowling) 18.3 sq ft

REFERENCE

1. Jones, Robert T., and Cohen, Doris: An Analysis of the Stability of an Airplane with Free Controls. Rep. No. 709, NACA, 1941.

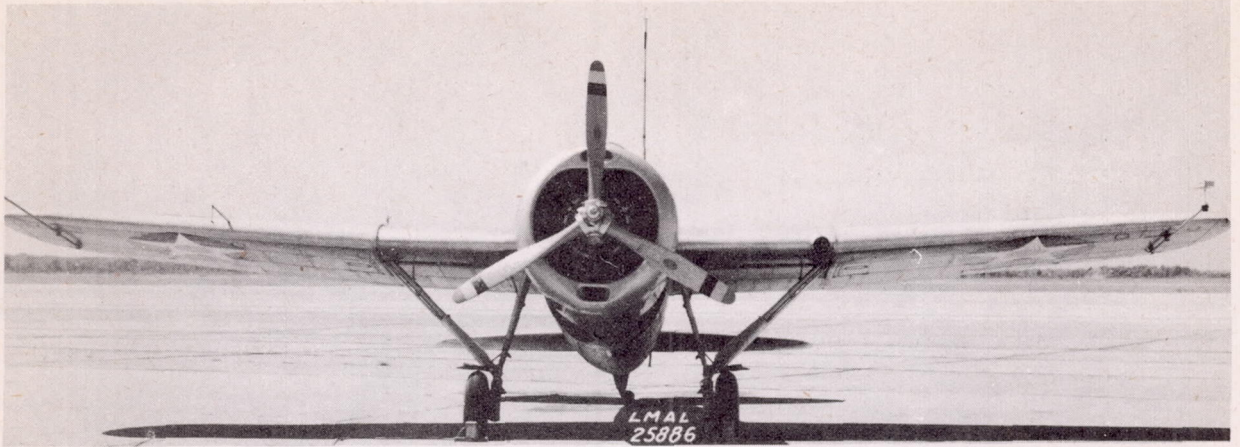

Figure 1.— Front view of Brewster XSBA-1 airplane.



Figure 2.— Three-quarter front view of Brewster XSBA-1 airplane.



Figure 3.— Side-view of Brewster XSBA-1 airplane.

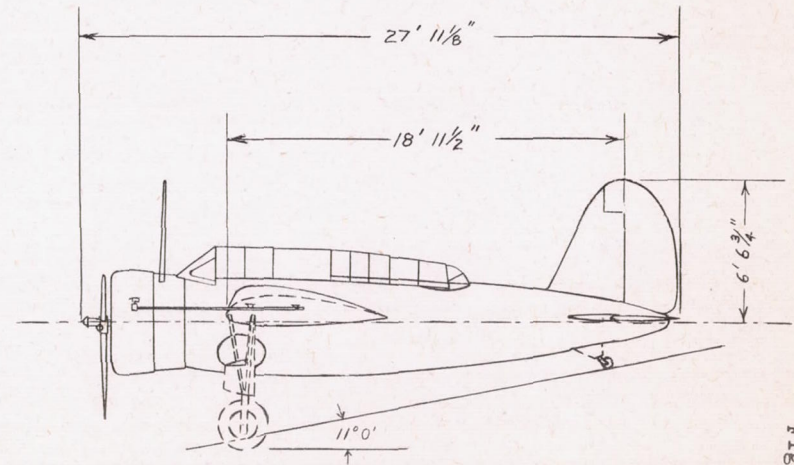
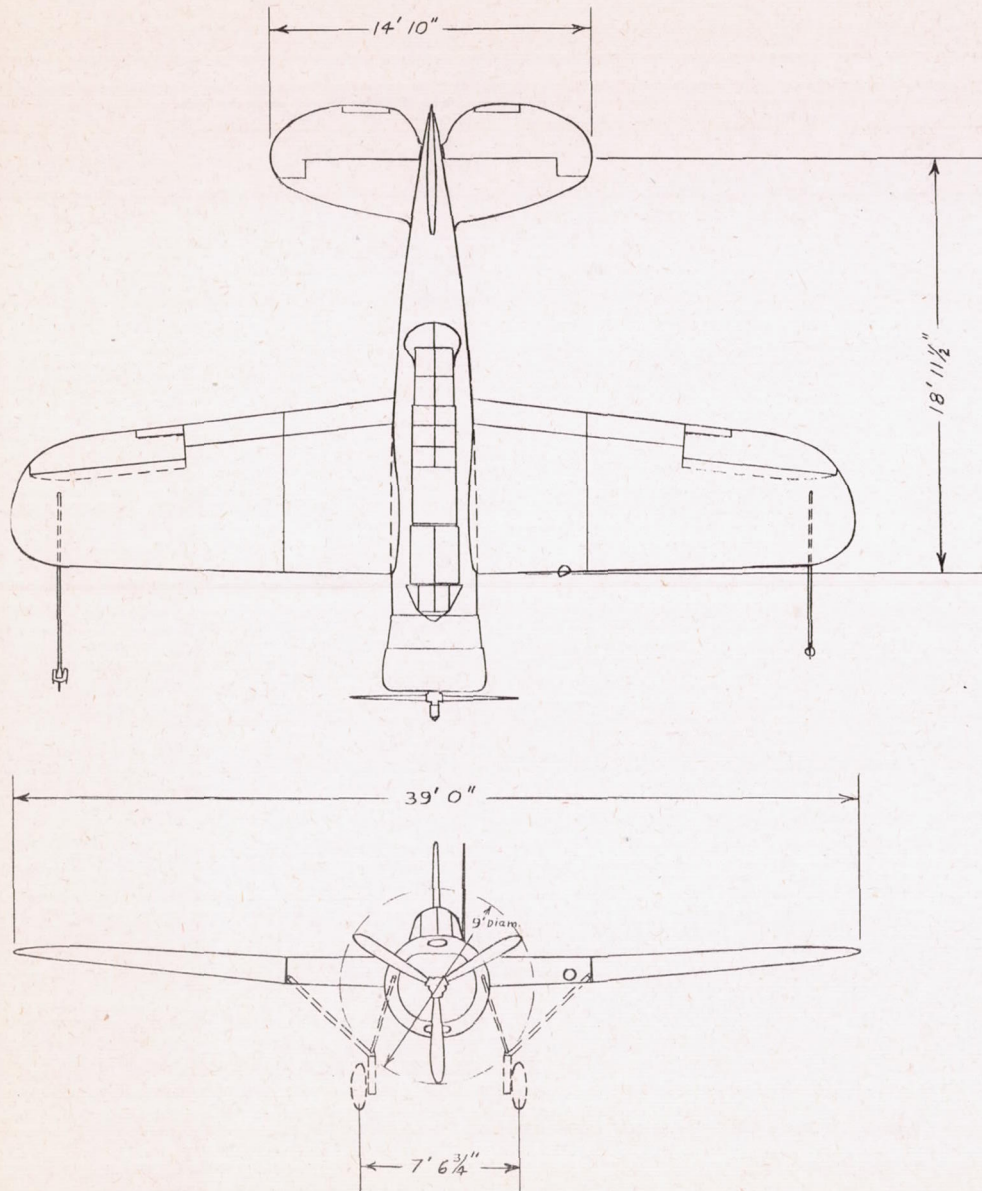

Figure 4. - Three-view drawing of the Brewster XSBA-1 airplane.

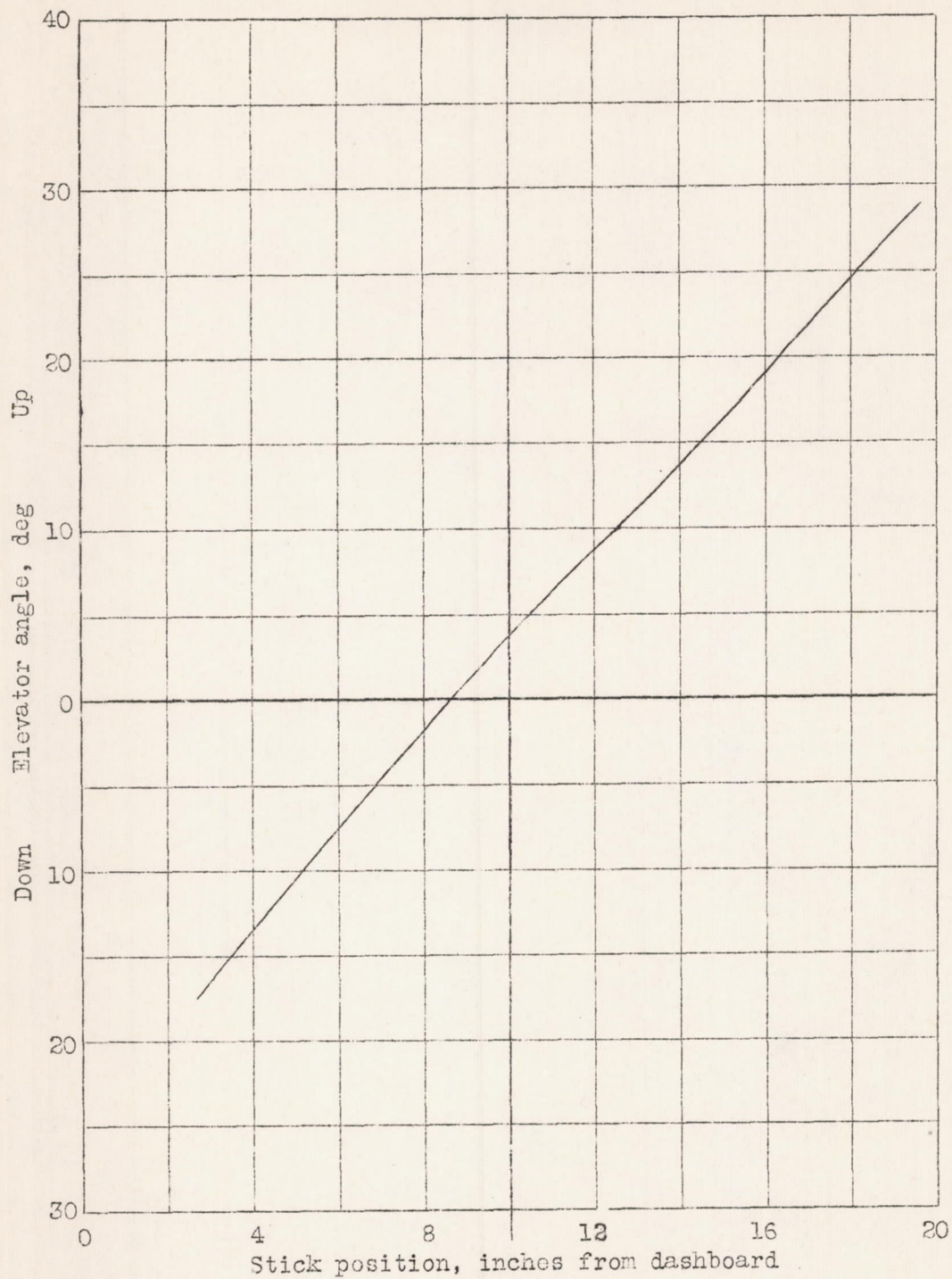

Figure 5.- Variation of elevator angle with position of the top of the control stick in front cockpit, Brewster XSBA-1 airplane.

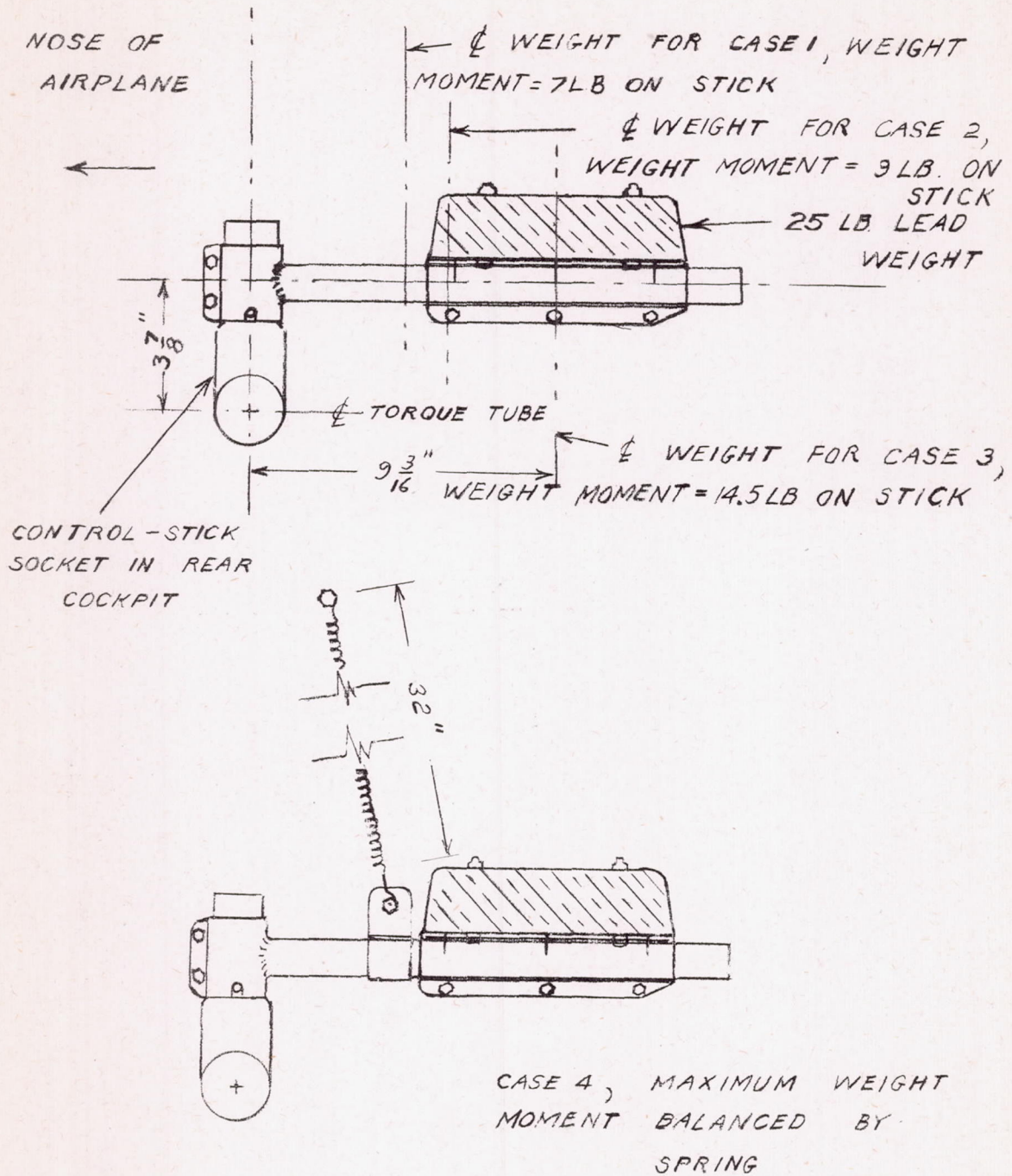

Figure 6. - Arrangements of weights and springs tested in Brewster XSBA-1 airplane.

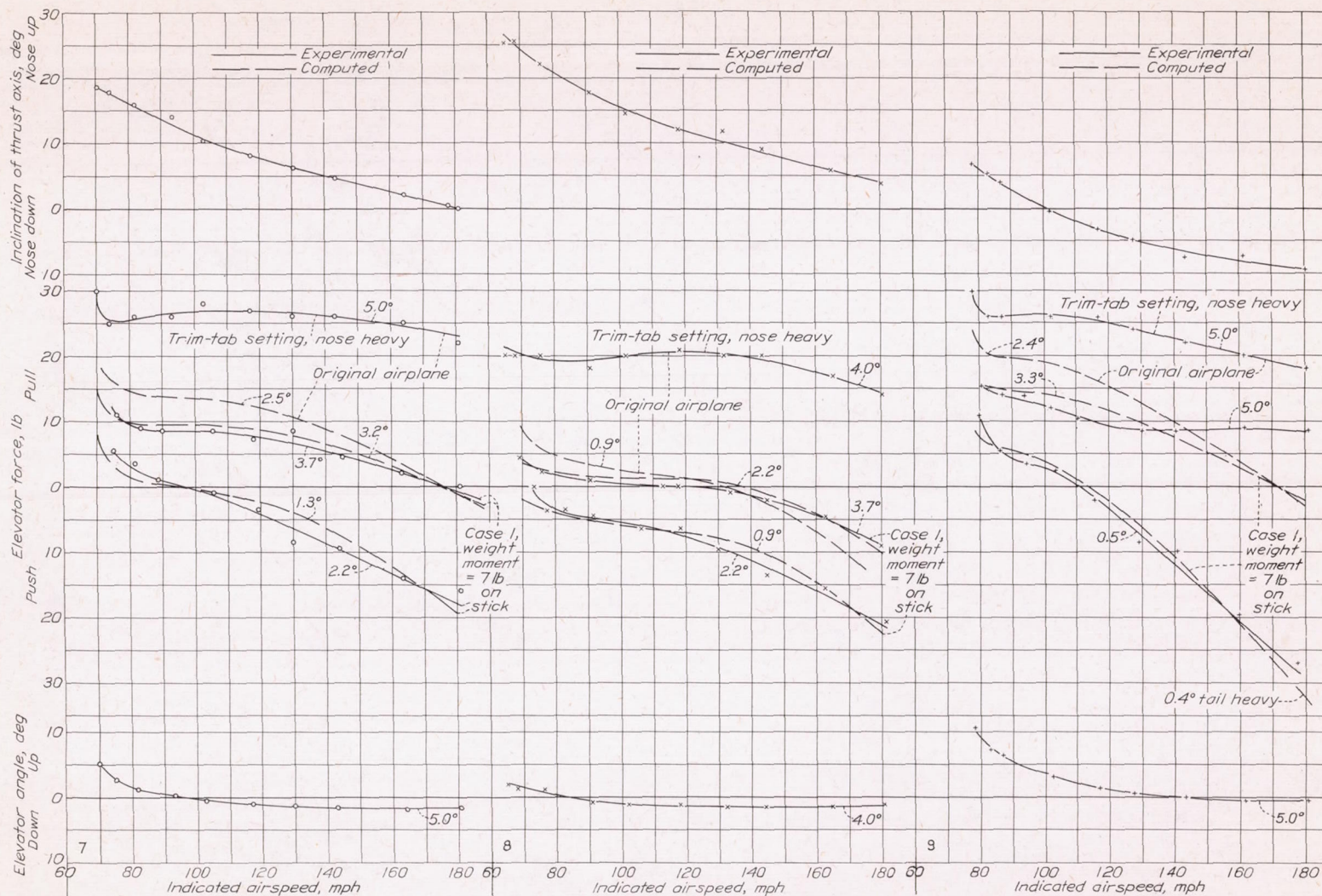

Figure 7.- Variation of elevator angle, stick force, and inclination of thrust axis with indicated airspeed in the cruising condition, Brewster XSBA-1 airplane.

Figure 8.- Variation of elevator angle, stick force, and inclination of thrust axis with indicated airspeed in the climbing condition, Brewster XSBA-1 airplane.

Figure 9.- Variation of elevator angle, stick force, and inclination of thrust axis with indicated airspeed in the gliding condition, Brewster XSBA-1 airplane.

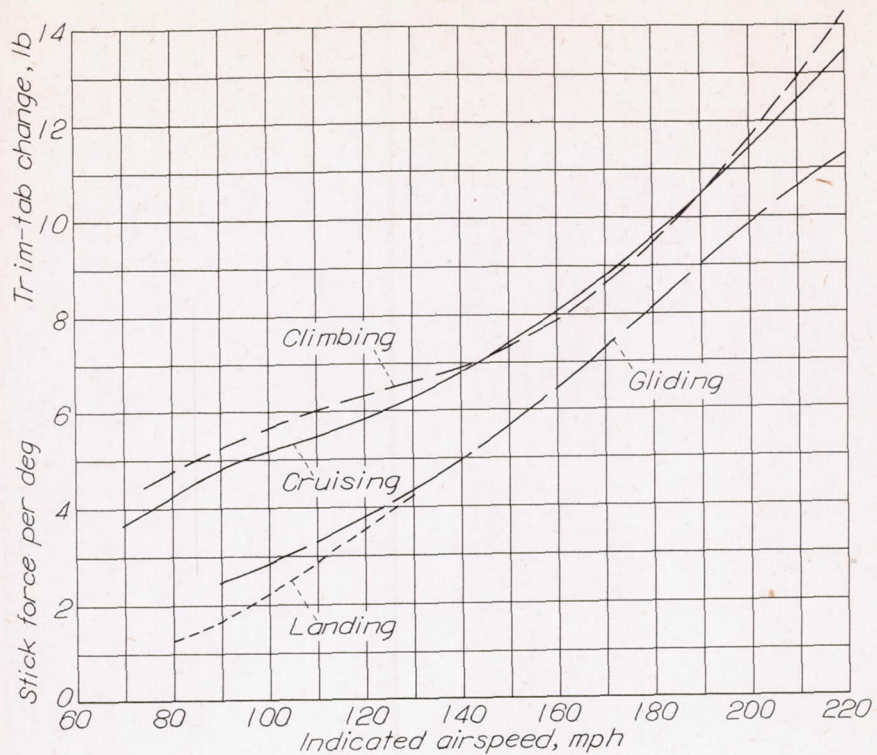

Figure 10.- Variation of stick force per degree trim-tab change with indicated airspeed. Brewster XSBA-1 airplane.

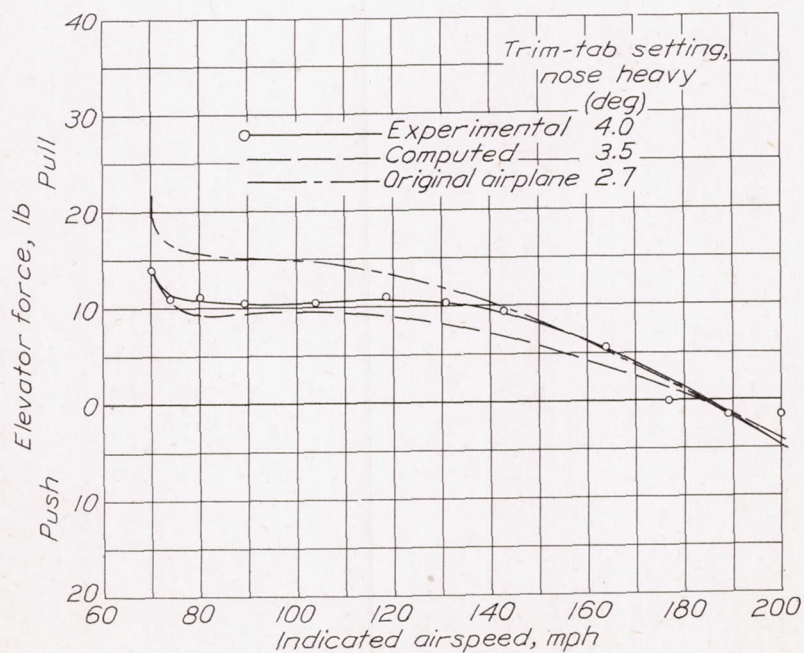

Figure 11.- Variation of stick force with indicated airspeed in the cruising condition for case 2, weight moment equals 9 pounds on stick. Brewster XSBA-1 airplane.

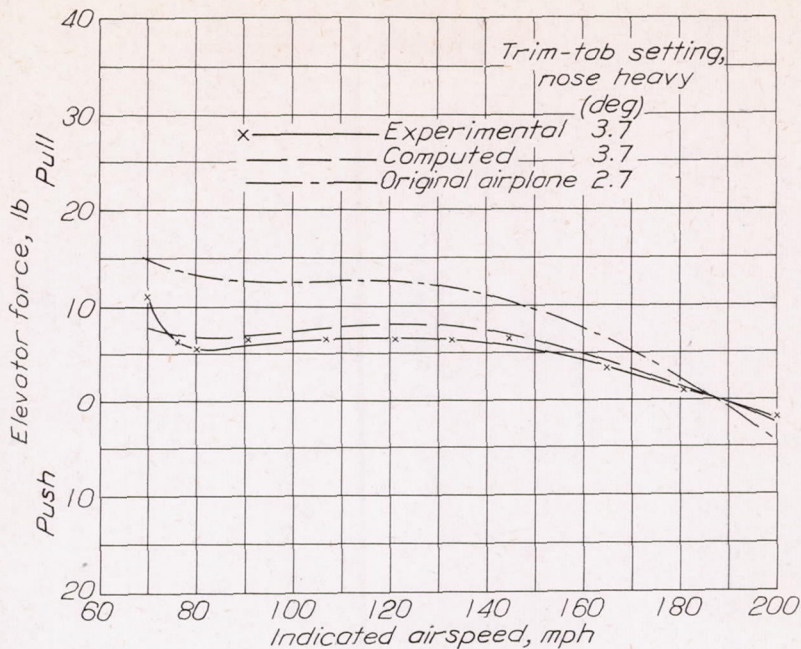

Figure 12.- Variation of stick force with indicated airspeed in the climbing condition for case 2, weight moment equals 9 pounds on stick. Brewster XSBA-1 airplane.

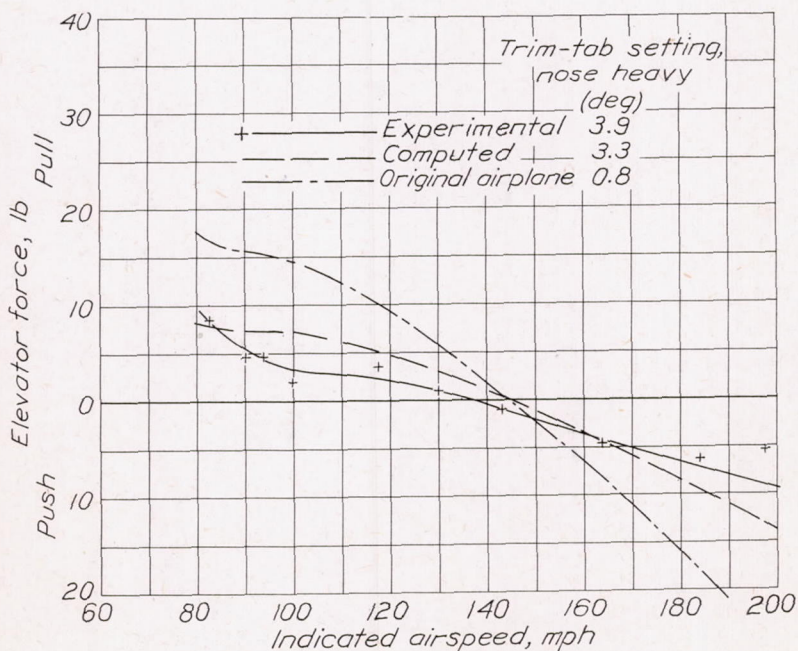

Figure 13.- Variation of stick force with indicated airspeed in the gliding condition for case 2, weight moment equals 9 pounds on stick. Brewster XSBA-1 airplane.

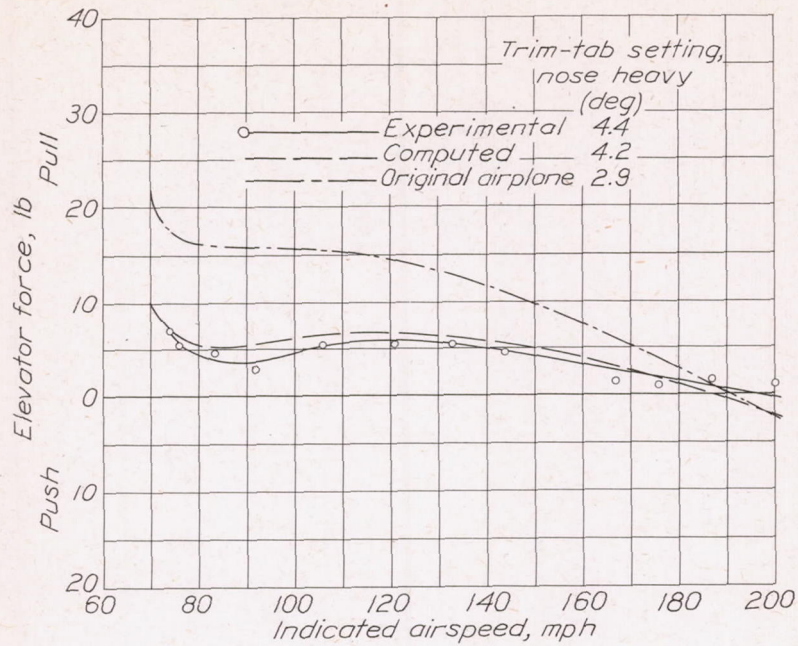

Figure 14.- Variation of stick force with indicated airspeed in the cruising condition for case 3, weight moment equals 14.5 pounds on stick. Brewster XSBA-1 airplane.

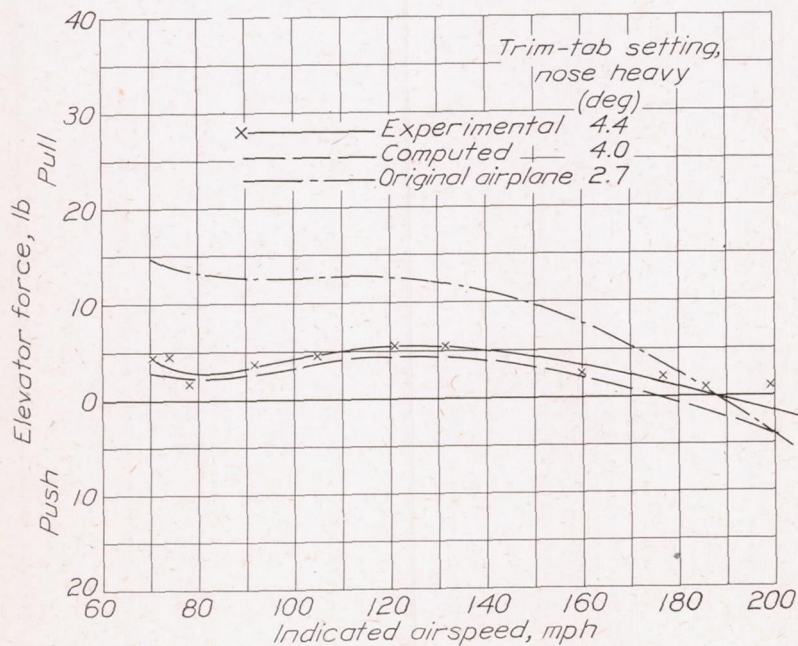

Figure 15.- Variation of stick force with indicated airspeed in the climbing condition for case 3, weight moment equals 14.5 pounds on stick. Brewster XSBA-1 airplane.

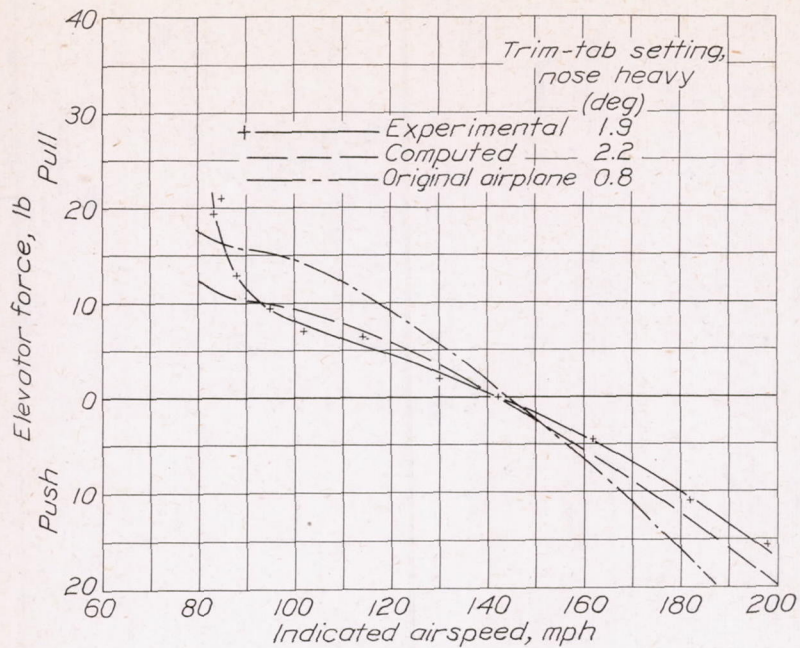

Figure 16.- Variation of stick force with indicated airspeed in the gliding condition for case 3, weight moment equals 14.5 pounds on stick. Brewster XSBA-1 airplane.

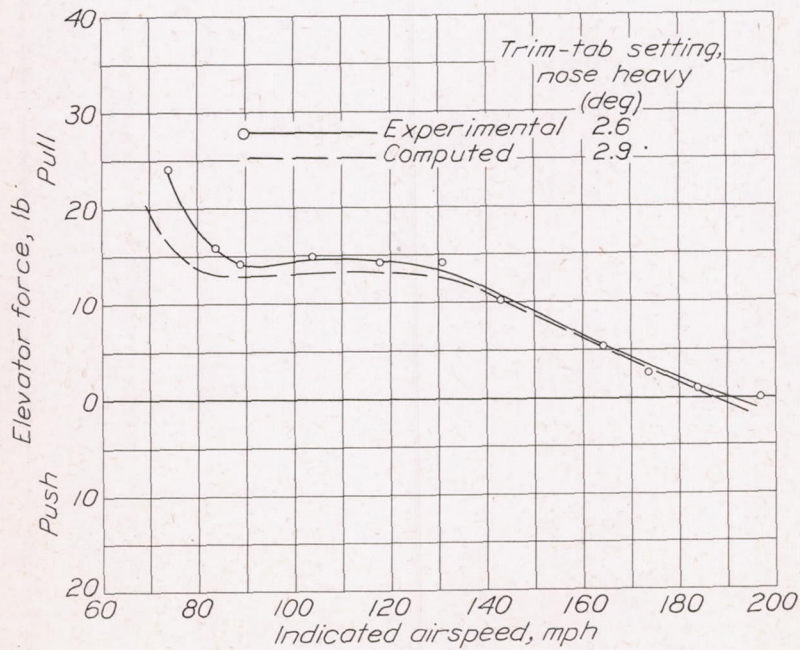

Figure 17.- Variation of stick force with indicated airspeed in the cruising condition for case 4, maximum weight moment offset by spring. Brewster XSBA-1 airplane.

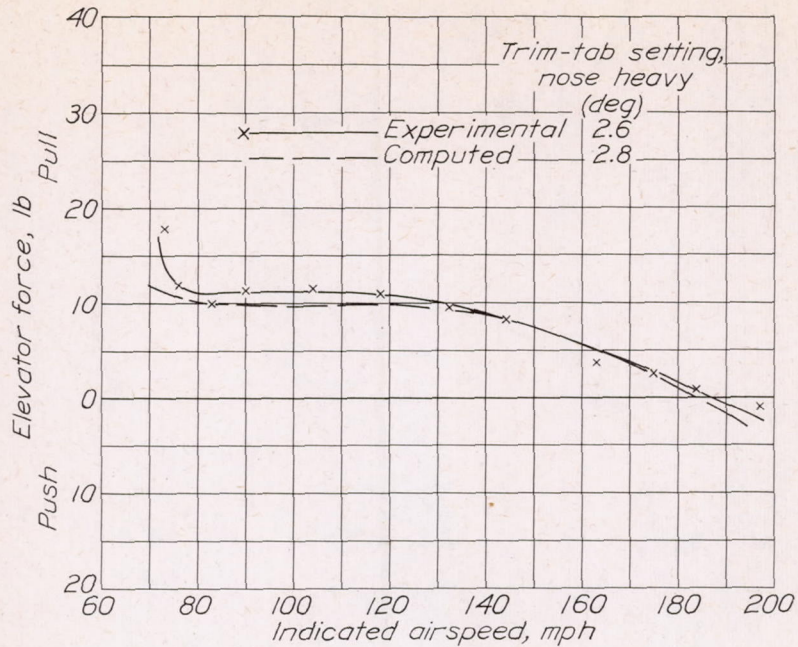

Figure 18.- Variation of stick force with indicated airspeed in the climbing condition for case 4, maximum weight moment offset by spring. Brewster XSBA-1 airplane.

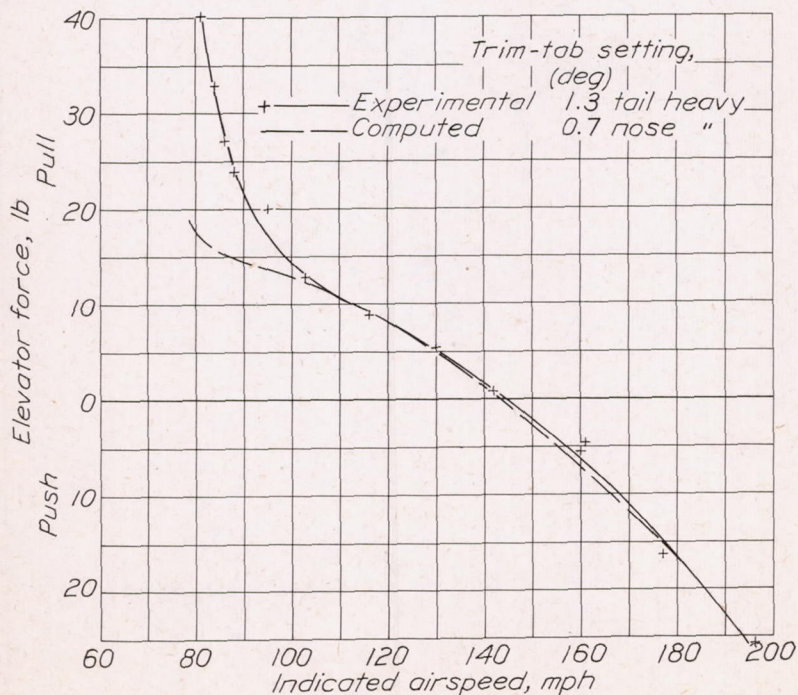

Figure 19.- Variation of stick force with indicated airspeed in the gliding condition for case 4, maximum weight moment offset by spring. Brewster XSBA-1 airplane.

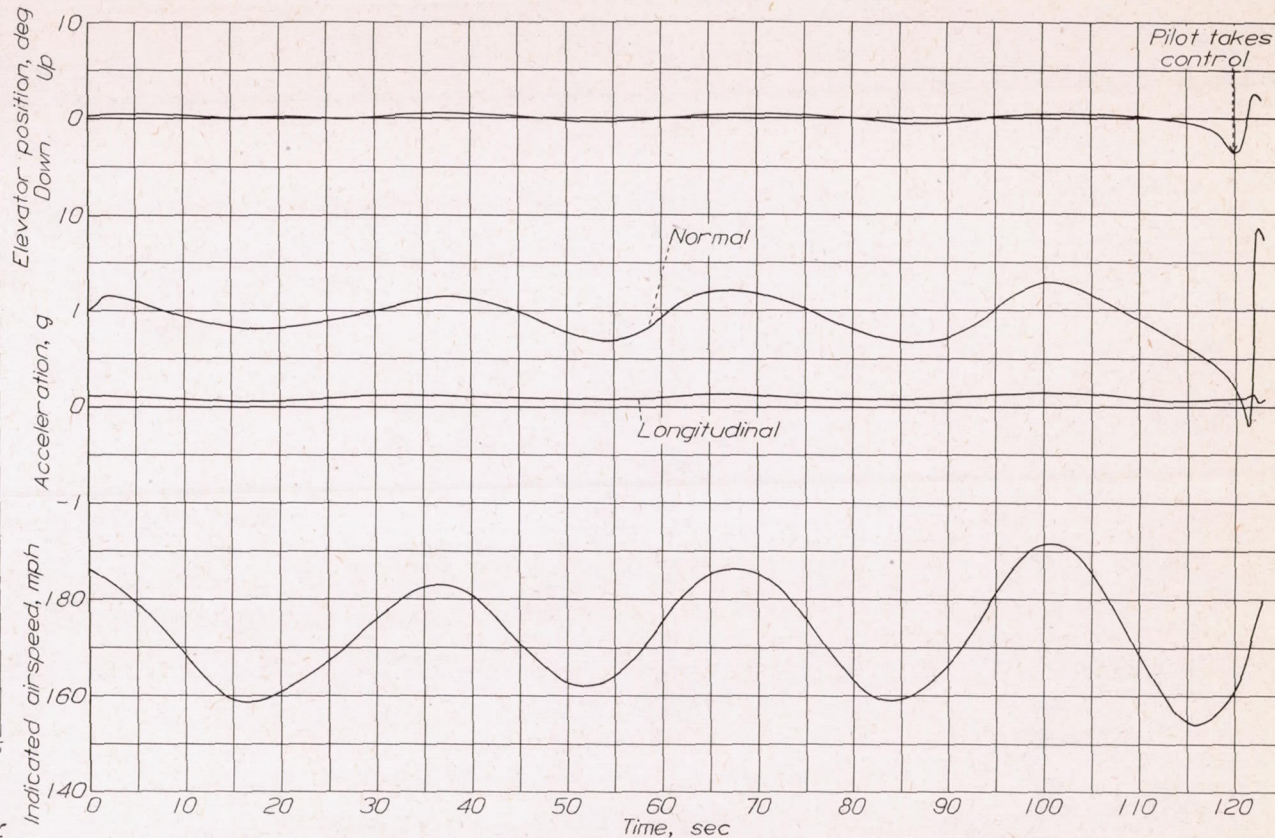
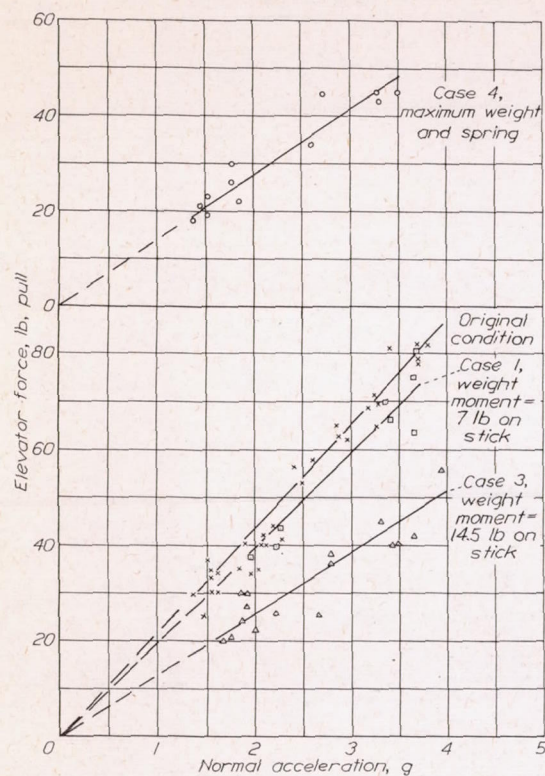

Figure 20.- Variation of elevator force with normal acceleration in 180° turns made at various speeds; Brewster XSBA-1 airplane in original condition and with three arrangements of weights and springs.

Figure 21.- Time history of long-period or phugoid longitudinal oscillation of Brewster XSBA-1 airplane with free controls for case 4 (maximum weight moment offset by spring). Divergence into dive at end of record is stopped by pilot resuming control.

TITLE: Effect of Spring and Gravity Moments in the Control System on the Longitudinal Stability of the Brewster XSBA-1 Airplane
AUTHOR(S): Phillips, W. H.
ORIGINATING AGENCY: National Advisory Committee for Aeronautics, Washington, D. C.
PUBLISHED BY: (Same)

ATI-13443

REVISION

(None)

ORIG. AGENCY NO.

ARR-L-263

PUBLISHING AGENCY NO.

DATE	DOC. CLASS.	COUNTRY	LANGUAGE	PAGES	ILLUSTRATIONS
April '42	Unclass.	U.S.	Eng.	23	photos, table, graphs, drwgs

ABSTRACT:

Stick-force variations with speed and maneuvering stick forces may be adjusted individually with combinations of weight and spring moments. Flight tests showed that the maneuvering forces of the XSBA-1 scout bomber could not be reduced below a certain minimum without encountering an unstable condition in which the airplane diverged from straight flight into a dive with the controls free. Weight moments large enough to increase the control system moment of inertia appreciably were considered undesirable.

DISTRIBUTION: Request copies of this report only from Originating Agency

DIVISION: Aerodynamics (2)

SECTION: Stability and Control (1)

SUBJECT HEADINGS: Longitudinal stability (56020.32);
Airplanes - Control systems (08395); Stability - Stick free
(891B9); XSBA-1 (89189) (08935)

ATI SHEET NO.: R-2-1-28

Air Documents Division, Intelligence Department
Air Materiel Command

AIR TECHNICAL INDEX

Wright-Patterson Air Force Base
Dayton, Ohio