

Reproduction Quality Notice

This document is part of the Air Technical Index [ATI] collection. The ATI collection is over 50 years old and was imaged from roll film. The collection has deteriorated over time and is in poor condition. DTIC has reproduced the best available copy utilizing the most current imaging technology. ATI documents that are partially legible have been included in the DTIC collection due to their historical value.

If you are dissatisfied with this document, please feel free to contact our Directorate of User Services at [703] 767-9066/9068 or DSN 427-9066/9068.

**Do Not Return This Document
To DTIC**

Reproduced by
AIR DOCUMENTS DIVISION



HEADQUARTERS AIR MATERIEL COMMAND

WRIGHT FIELD, DAYTON, OHIO

The
U.S. GOVERNMENT

IS ABSOLVED

FROM ANY LITIGATION WHICH MAY

ENSUE FROM THE CONTRACTORS IN -

FRINGING ON THE FOREIGN PATENT

RIGHTS WHICH MAY BE INVOLVED.

HEADQUARTERS AIR MATERIEL COMMAND

WRIGHT FIELD, DAYTON, OHIO

REEL - C

3 0 8

A.T.I.

8 2 8 7

D10.13/888

NATIONAL ADVISORY COMMITTEE FOR AERONAUTICS

TECHNICAL MEMORANDUM

No. 1135

ATI No. 8287

AIR DOCUMENTS BRANCH
AAC WRIGHT FIELD
RC-308 F 8287

THE LOAD DISTRIBUTION IN BOLTED OR RIVETED JOINTS
IN LIGHT-ALLOY STRUCTURES

By F. Vogt

Reprint of Report No. S.M.E. 3300, October 1944

Issued by the Royal Aircraft Establishment
Farnborough, England

RECEIVED
AUG 8 1947

FILE COPY



RETURN TO

Special Documents Branch - TSRWF-6
Wright Field Reference Library Section
Air Documents Division - Intelligence (T-2)
Wright Field, Dayton, Ohio.

Washington
April 1947

NATIONAL ADVISORY COMMITTEE FOR AERONAUTICS

TECHNICAL MEMORANDUM NO. 1135

THE LOAD DISTRIBUTION IN BOLTED OR RIVETED JOINTS
IN LIGHT-ALLOY STRUCTURES¹

By F. Vogt

SUMMARY

This report contains a theoretical discussion of the load distribution in bolted or riveted joints in light-alloy structures which is applicable not only for loads below the limit of proportionality but also for loads above this limit. The theory is developed for double and single shear joints. The methods given are illustrated by numerical examples and the values assumed for the bolt (or rivet) stiffnesses are based partly on theory and partly on known experimental values. It is shown that the load distribution does not vary greatly with the bolt (or rivet) stiffnesses and that for design purposes it is usually sufficient to know their order of magnitude. The theory may also be directly used for spot-welded structures and, with small modifications, for seam-welded structures. The computational work involved in the methods described is simple and may be completed in a reasonable time for most practical problems.

A summary of earlier theoretical and experimental investigations on the subject is included in the report.

1. INTRODUCTION

The distribution of the loads on rivets in steel structures has received much attention during the last 30 years and a summary of references on this subject is given in section 2. It has been shown that the load distribution is not usually uniform, and this has been explained theoretically by considering the relative stiffnesses of the different parts of the structure. The actual stiffnesses have been calculated in this way from the observed nonuniformities in the load distribution.

¹Reprint of Report No. S.M.E. 3300, Oct. 1944; issued by the Royal Aircraft Establishment, Farnborough, England.

The theoretical information available, however, is only valid for loads below the limit of proportionality, and for aircraft structures the behavior above this limit is of great importance. This report contains a theoretical discussion of the load distribution in bolted or riveted joints that is more complete, and particular attention is given to the case in which the loads exceed the limit of proportionality.

Any theoretical treatment must be based on the knowledge of the local displacement at a bolt (or a rivet) as a function of the shear load carried, and the load distribution for any number of bolts or rivets may then be found mathematically. The basic problem is therefore to determine the local displacement at a bolt, or the stiffness of the bolt, as a function of the load. This displacement includes the bending and shear deformations in the bolt itself together with the local compression in the plates due to the bearing stresses. This displacement can to some extent be estimated theoretically when the loads are below the limit of proportionality, and this is shown in 3.2. This is not possible for loads above this limit, and, as the experimental information at present available is not sufficient, further tests are necessary.

In this connection the difference in behavior of bolts and hot or cold rivets, and of bolts or rivets in single or double shear, is important. In hot riveting the plates are pressed together and the shear load up to a certain amount is carried by friction; when this friction fails the rivet carries the shear load directly. In cold riveting in light-alloy structures the pressure between the plates is comparatively much less and consequently the load carried by friction is also less. The pressure in bolted connections is entirely dependent on the tightening of the nuts and cannot be relied upon in aircraft structures because of the effects of vibration. The diameter of the rivet is increased during the process of riveting due to compression and this is particularly the case in hot riveting. The rivets not only fill the hole drilled in the plate but may even enlarge it. In bolted connections the holes usually are drilled with a slightly larger diameter than the bolts, and when the shear load is increased above that taken by friction the plates will slip before the bolts can act again. This slip can be eliminated only by using bolts turned to a close fit. Owing to both these reasons hot rivets can be assumed to be stiffer than cold rivets of the same nominal dimensions, and they are both stiffer than bolts. Comparison between the series of tests available is difficult and, further, the value of tests on steel structures for the design of light-alloy structures is limited. It should be remembered also that even if rivets in single shear are designed for the same bearing and shear stresses as for rivets in double shear, they may behave very differently, and this is most noticeable when the plates are thin and flexible in comparison with the rivets. In the case of single shear the plates will be bent locally, and the consequent tilting of the rivets may increase considerably the displacement between the plates. Because experimental data on these fundamental parts of the

problem are partly lacking, the analysis developed in this report is based on assumed rivet and bolt stiffnesses that can be only partly checked either by theory or by available test results.

2. SUMMARY OF REFERENCES TO EARLIER INVESTIGATIONS

C. Batho in reference 1 based the theory of the load distribution on the principle of least work; it is developed for double shear joints by assuming known values of the rivet stiffnesses. The theory is applicable only to loads below the limit of proportionality, and consideration is given to joints between tapered members. The rivet stiffnesses were calculated from tests made on joints with a large number of rivets.

Tests reported by J. Montgomery on pages 727 and 755 of reference 2 were made on steel plates with single to quadruple riveted lap joints that are ordinarily used in shipbuilding, that is, rivets in single shear. A main purpose of these tests was to determine the load at which the frictional resistance due to compression between the plates fails and the non-uniformity of the load distribution in multiple row rivets was confirmed. The tests given in the paper cannot, however, be used for an accurate determination of the stiffness of the rivets because this would involve complicated calculations.

Strain tests on steel gusset plates are reported by T. Wyss (reference 3) and indicate a nonuniform load distribution, but the tests cannot be used for the determination of the rivet stiffnesses.

In reference 4 by W. Pleinings tests on riveted steel connections are referred to, and the limit of proportionality can only to some extent be judged. Tests were made also on dural plates connected by a steel bolt in double shear to steel straps, and give valuable information on the limit of proportionality so far as bearing stresses on dural plates are concerned. The stiffness of dural bolts connecting dural plates cannot be found from these tests.

A paper by E. Cassens (reference 5) contains a theory for the calculation of the loads on rivets connecting a plate to a beam in bending. The theory is not adequate as essential features are omitted and the results are partly misleading. A few tests on the stiffness of rivets in steel and dural structures are also referred to, but no details of plate dimensions or test methods are given. Although the author applies these test results to rivets in single shear it is not clear whether the tests were conducted on rivets in single or double shear.

Steel Structures Research Committee Reports (reference 6) include theoretical investigations and also tests. In the first report (pp. 100-179), Batho gives an improvement of his theoretical treatment in reference

1 which is valid below the limit of proportionality. Tests on joints with a large number of rivets or bolts were made by Sarawi in connection with this theoretical investigation. The load carried by friction in the case of bolted connections was measured also as a function of the torque on the bolts. This last matter also is dealt with in the second report (pp. 138-176). On pages 289-291 and also on pages 295 and 296 of the final report the deformation at rivets and bolts due to shear forces is considered.

In these reports references are given also to other papers on this subject:

C. Findeisen, Hertwig and Peterman, and Hovgaard (references 7 to 9).

Bleich, in his German textbook on steel bridges also has published, in 1924, a theory of the load distribution on rivets. The references available indicate that only the simple problem of loads below the limit of proportionality is considered.

Reference 10 by O. Volkerson gives a theoretical discussion of the load distribution on rivets based on a "substitute system" with a continuous connection between plate and straps instead of connection at discrete points. This does not appear to simplify the analysis and the method is unsuitable for tapered sections and for loads above the limit of proportionality. The extension of the theory to nonlinear deformations is incorrect and gives misleading results. The direct measurements of the stiffness of dural rivets constitute the main value of his work and these test series are the only ones of real value that have been published on this subject. The results of the different tests are discussed in 3.3.

Little original work concerning the load distribution on rivets is given in reference 11 by H. Portier, but in part VII the Bleich and Volkerson methods are given. In addition, some investigations are given on temperature stresses.

3. GENERAL THEORY OF DOUBLE SHEAR JOINTS

3.1 Distribution of Loads below Limit of Proportionality

A double shear joint is shown in figure 1(a), and in figure 1(b) the loads carried by the different members of the joint also are shown. Assume the bolts to carry the shear loads $P_1, P_2, P_3, P_4, \dots$, half of which are carried at each side strap. The tension loads in the different sections of the plates are then

$$Q_1 = P_1$$

$$Q_2 = P_1 + P_2$$

$$Q_3 = P_1 + P_2 + P_3, \text{ and so forth}$$

and the loads in the two side straps taken together are

$$R_1 = P - Q_1$$

$$R_2 = P - Q_2$$

$$R_3 = P - Q_3, \text{ and so forth}$$

where P is the total load carried by the joint.

The total local displacement at each bolt (in bolt, straps, and plate) may be written in the form

$$\delta_1 = c_1 P_1 \delta_0$$

$$\delta_2 = c_2 P_2 \delta_0, \text{ and so forth}$$

where δ_0 is a quantity with which all deformations are compared, and $c_1, c_2,$ and so forth, are nondimensional parameters that are constants below the proportional limit and functions of the loads above the proportional limit.

The extension of each section of the plate and of the side straps may in the same way be written in the form

$$\lambda_1^1 = a_1 Q_1 \delta_0$$

$$\lambda_2^1 = a_2 Q_2 \delta_0, \text{ and so forth}$$

and

$$\lambda_1 = b_1 R_1 \delta_0$$

$$\lambda_2 = b_2 R_2 \delta_0, \text{ and so forth}$$

respectively.

Now

$$\delta_1 + \lambda_1^1 = \lambda_1 + \delta_2$$

$$\delta_2 + \lambda_2^1 = \lambda_2 + \delta_3, \text{ and so forth}$$

and these give the following equations,

$$c_1 P_1 + a_1 P_1 = b_1 (P - P_1) + c_2 P_2$$

$$c_2 P_2 + a_2 (P_1 + P_2) = b_2 (P - P_1 - P_2) + c_3 P_3$$

$$c_3 P_3 + a_3 (P_1 + P_2 + P_3) = b_3 (P - P_1 - P_2 - P_3) + c_4 P_4$$

and so on, if there are more than four bolts,

$$(a_1 + b_1 + c_1) P_1 - c_2 P_2 = b_1 P$$

$$(a_2 + b_2) P_1 + (a_2 + b_2 + c_2) P_2 - c_3 P_3 = b_2 P$$

$$(a_3 + b_3)(P_1 + P_2) + (a_3 + b_3 + c_3)P_3 - c_4 P_4 = b_3 P, \text{ and so forth}$$

Further, if there are n bolts

$$P = P_1 + P_2 + P_3 + \dots + P_n$$

and from these simple equations the loads P_1 , P_2 , and so forth, carried by the bolts are easily calculated once the coefficients a , b , and c , which represent the relative stiffnesses of the parts of the joint, are known.

If the bolts are arranged in several rows normal to the tensile load, each row containing a number of bolts, the calculations may be carried out as above with the following modification. Let the number of bolts in the i th row be m_i and let P_i be the total load on all these bolts. The load on each bolt will then be P_i/m_i . The terms $c_i P_i$ in the equations which represent the displacement at an individual bolt should then be replaced by $c_i P_i/m_i$; otherwise, the equations are unaltered.

Example 1

Assume the stiffness of all sections of the plates and straps to be the same and take $\delta_0 = l/EA$, where A is the mean effective section of the plate, so that

$$a_1 = a_2 = a_3 = \dots = b_1 = b_2 = b_3 = \dots = 1$$

Assume further that the stiffness of all the bolts is the same:

$$c_1 = c_2 = c_3 = \dots = c$$

The equations are then

$$(2 + c) P_1 = c P_2 = P$$

$$2P_1 + (2 + c) P_2 = c P_3 = P$$

$$2P_1 + 2P_2 + (2 + c) P_3 = c P_4 = P, \text{ and so forth}$$

and because of symmetry,

$$P_1 = P_n, P_2 = P_{n-1}, P_3 = P_{n-2}, \text{ and so forth}$$

which together with the relation

$$P = P_1 + P_2 + \dots + P_n$$

gives the following results.

For 3 bolts: $P_1 = P_3 = P(1 + c)/(2 + 3c)$ and $P_2 = P c/(2 + 3c)$

For 4 bolts: $P_1 = P_4 = P(2 + c)/(4 + 4c)$ and $P_2 = P_3 = P c/(4 + 4c)$

For 5 bolts: $P_1 = P_5 = P(2 + 4c + c^2)/(4 + 10c + 5c^2)$

$$P_2 = P_4 = P(c + c^2)/(4 + 10c + 5c^2)$$

and $P_3 = P c^2/(4 + 10c + 5c^2)$

For 6 bolts: $P_1 = P_6 = P(4 + 6c + c^2)/(8 + 16c + 6c^2)$

$$P_2 = P_5 = P(2c + c^2)/(8 + 16c + 6c^2)$$

and $P_3 = P_4 = P c^2/(8 + 16c + 6c^2)$

With, for instance, $c = 2$, these relations give:

For 3 bolts: $P_1 = P_3 = 0.375 P$ or $1.125 P/3$

$$P_2 = 0.25 P$$

For 4 bolts: $P_1 = P_4 = 0.333 P$ or $1.333 P/4$

$$P_2 = P_3 = 0.167 P$$

For 5 bolts: $P_1 = P_5 = 0.319 P$ or $1.595 P/5$

$$P_2 = P_4 = 0.136 P$$

$$P_3 = 0.091 P$$

For 6 bolts: $P_1 = P_6 = 0.312 P$ or $1.87 P/6$

$$P_2 = P_5 = 0.125 P$$

$$P_3 = P_4 = 0.063 P$$

This gives the well-known result, that by using relatively stiff bolts (when c is small) an increase in the number of bolts does not reduce the load on the highest loaded bolts very much, provided the loads are below the proportional limit. By using very flexible bolts (when c is large) the load distribution approximates to a uniform distribution:

$$P_i \rightarrow P/M \text{ as } c \rightarrow \infty$$

This is to some extent realized when all the bolts undergo large non-linear deformations while the plate and straps still remain stiff. (See 3.7 and 3.8.)

Example 2

A uniform load distribution can be obtained also by tapering the section of the plate and straps in proportion to the load to be carried by this desired distribution. For instance, in the case of five bolts the relative stiffnesses of the different sections should be chosen as follows:

$$\begin{aligned} a_4 = b_1 = 1 & \quad \text{that is section } A_4 = P_1 \\ a_3 = b_2 = 4/3 & \quad \text{that is section } A_3 = B_2 = 0.75 B_1 \\ a_2 = b_3 = 2 & \quad \text{that is section } A_2 = B_3 = 0.5 B_1 \\ a_1 = b_4 = 4 & \quad \text{that is section } A_1 = B_4 = 0.25 B_1 \end{aligned}$$

and if $c_1 = c_2 = c_3 = c_4 = c_5$, it is found that $P_1 = P_2 = P_3 = P_4 = P_5$, and this result is independent of the value of c .

More generally, a uniform load distribution is obtained if all bolts have the same stiffness and the cross sections of the plates are chosen so that

$$B_1 = A_1 (n - 1)/i$$

but it is hardly practicable, however, to taper to this extent in actual constructions.

If the taper is chosen as follows,

$$\begin{aligned} a_4 = b_1 = 1 & \quad \text{that is section } A_4 = B_1 \\ a_3 = b_2 = 1.25 = 5/4 & \quad \text{that is section } A_3 = B_2 = 0.8 B_1 \\ a_2 = b_3 = 1.667 = 5/3 & \quad \text{that is section } A_2 = B_3 = 0.6 B_1 \\ a_1 = b_4 = 2.5 = 5/2 & \quad \text{that is section } A_1 = B_4 = 0.4 B_1 \end{aligned}$$

it is found that for $c = 2$,

$$P_1 = P_5 = 0.245 P$$

and

$$P_2 = P_4 = 0.174 P$$

$$P_3 = 0.162 P$$

instead of 0.319 P, 0.136 P, and 0.091 P if there were no taper. Similarly, for $c = 4$,

$$P_1 = P_5 = 0.231 P$$

and

$$P_2 = P_4 = 0.183 P$$

$$P_3 = 0.172 P$$

instead of 0.274 P, 0.161 P, and 0.129 P if there were no taper.

With this degree of tapering, the maximum load on any bolt for $c = 2$ is reduced from 1.595 to 1.225 times 0.2 P and for $c = 4$ is reduced from 1.370 to 1.155 times 0.2 P.

In other words, the taper has considerably reduced the overload on the outer bolts to nearly the mean value 0.2 P.

If the sections 1.0 - 0.8 - 0.6 - 0.4 are the maximum degree of taper that can be used in order to maintain the necessary strength of plate, it is to be questioned whether this is the best possible taper. A detailed investigation indicates that the best load distribution is obtained by making the cross section of the plate as small as possible between the last two bolts and by tapering only after the second bolt. For instance, with the taper 1.0 - 1.0 - 0.7 - 0.4 and $\nu = 4$ the rivet loads are 0.229 P, 0.181 P, 0.180 P, 0.181 P, and 0.229 P. The reduction of the maximum rivet load is only from 0.231 P to 0.229 P, which is negligible. But the stresses in the plates are reduced also by this change in the taper, and even if the effect of this alteration is of little importance, it is at least an improvement in the design of the structure. The load distribution for the particular case of five bolts is shown in figure 2.

3.2 Displacement at Rivets or Bolts and Theoretical Analysis for Loads below the Limit of Proportionality

Below the limit of proportionality, and assuming that no load is carried by friction, the local deformation at the bolt and the hole can be approximately calculated in the two extreme cases when the diameter of the bolt is either very large or very small in comparison with the thicknesses t of the plate and the straps.

(1) Diameter very large.— In this case the bolt is very stiff and will then be only slightly bent. The distribution of load along the axis of the bolt can be assumed to be fairly even, as shown in figure 3(b). The direct shear and bending deformation in the bolt itself can then easily be calculated. Let f_1 be the displacement between the plate and the straps due to this part of the deformation. This displacement can obviously be taken as the difference between the mean ordinate for the elastic line of the bolt for the thickness t_2 of the plate minus the mean ordinate for the thickness t_1 of the straps, as indicated in figures 3(a) and 3(b). The detailed calculation gives

$$f_1 = (P/Ed) (9t_1^3 + 15t_1^2 t_2 + 10t_1 t_2^2 + 2t_2^3)/11.78d^3 \\ + 0.3 (P/Ed) (2t_1 + t_2)/d$$

where the first term represents the deformation due to bending and the second term that due to shear.

With $t_1 = 0.5t_2$, this gives

$$f_1 = (P/E) \left\{ 0.6(t_2/d) + (t_2/d)^3 \right\}$$

and with $t_1 = t_2$

$$f_1 = (P/E) \left\{ 0.9(t_2/d) + 3.0 (t_2/d)^3 \right\}$$

The bending of the bolt introduces nonuniformity of the load with a concentration toward the common surface of the plate and the straps, and thus reduces the bending of the bolt. In addition, rivet heads and tight nuts on the bolts will reduce the bending. The formula therefore gives decidedly too large a value for the displacement due to bending if d is small and can be only approximately correct for large values of d .

The direct compression due to bearing stresses in the plate, the straps, and the bolt must be added to this displacement due to bending of the bolt.

Coker and Filon (reference 12, p. 527) give the approximate stress distribution in an infinitely large plate with a loaded hole. The stress distribution includes a term proportional to $1/x$ where x is the distance from the center of the hole and integration from the edge of the hole to infinitely large values of x will therefore give infinitely large values of the displacement f_2 (see fig. 4(a)). Only the local deformation at the hole is required here and not the effect of the stresses away from the hole. It is therefore reasonable to integrate only up to certain values of x , and it is found that

for $x = d$ 1.0	$f_2 = (P/Et)$ 0.362
$x = d$ 1.5	$f_2 = (P/Et)$ 0.556
$x = d$ 2.0	$f_2 = (P/Et)$ 0.745
$x = d$ 3.0	$f_2 = (P/Et)$ 0.967, and so forth

For larger values of x , f_2 increases only very gradually, and, since $x = 3d$ takes into account more than the local strain, it is reasonable to take

$$f_2 = 0.9 P/Et$$

In the bolt itself there is a compression due to the bearing stresses which are approximately P/dt at the surface and half of this value at

the axis of the bolt. The corresponding compression between the surface and the axis of the bolt can be approximately taken as

$$f_3 = (1/E)(P/dt)(1.5/2)(d/2) = 0.375 P/Et$$

The bearing stresses in the plate and the bolt give approximately

$$(P/Et) (0.9 + 0.375) = (P/Et) 1.3 d/t$$

There is one such term for the middle plate (thickness t_2) and one for the straps (thickness t_1), and these together give

$$(P/Et) 1.3 (d/2t_1 + d/t_2)$$

The displacement at the bolt when the hole diameter is large is finally given by

$$(P/Et) f(d/t_1, d/t_2)$$

where f is a function of the relative dimensions,

and for $t_1 = 0.5 t_2$

$$\begin{aligned} f &= 1.3 (d/2t_1 + d/t_2) + 0.6t_2/d + (t_2/d)^3 \\ &= 2.6 d/t_2 + 0.6 t_2/d + (t_2/d)^3 \end{aligned}$$

and for $t_1 = t_2$

$$f = 1.95 d/t_2 + 0.9 t_2/d + 3 (t_2/d)^3$$

approximately.

These formulas are only valid for large values of d , and then the first term is the most important, and the others are only of minor importance.

(2) Diameter very small.— If the diameter of the bolt is very small in comparison with the thickness of the plate the displacement between the plate and the straps can only depend on the deformation in the bolt and the plates near their common surfaces.

1941 21 W. 1119

The ideal case is to some extent represented by assuming that the two surfaces are homogeneously connected over an area of diameter d . For this case the attachment may be found by means of the formulae for stress and strain in a semi-infinite body loaded at the surface, and for loads distributed over rectangular areas. The average displacement δ has been calculated (reference 13). Substituting a square of sides a for a circle with diameter $d = 1.08a$, both of which have the same area, it is found that for bolts in double-shear

$$\delta = 210.5 P/E\pi d^3 \cdot 0.91 = 1.93 P/E\pi d^3$$

This calculation gives too small a value for the displacement in the case of bolt or rivet connections because the bolts or rivets are not welded to the plates. In the contrary, a loading of the joint must produce openings between the bolt and the plate.

Another estimate may be made as follows by assuming that the bolt is completely built in at distances greater than $3d$, d being a certain parameter, from the common surfaces of the plate and the straps. The bolt is then in double-shear, as shown in Figure 2(b), and

$$\delta = (P/2\pi d) (3.78 + 6.68 \frac{d}{l})$$

and taking different values of l it is found that

for $l = 0.3d$
 $l = 0.5d$
 $l = 0.7d$
 $l = 1.0d$

$\delta = 1.3 P/\pi d^3$
 $\delta = 1.5 P/\pi d^3$
 $\delta = 2.7 P/\pi d^3$
 $\delta = 3.7 P/\pi d^3$

The coefficients can be intercalated only by tests, and provided that a value of l is assumed to be reasonable. Much depends on how closely the bolt fits the hole and if the hole is larger than the bolt the displacement will obviously be greatly increased.

(3) Interpolation. - By writing

$$\delta = (P/2\pi d) f$$

and plotting f as a function of l/d for very large and very small values of this ratio, the values of f for medium values of the ratio may be approximately obtained by interpolation as shown in Figure 2.

The ideal case is to some extent represented by spot-welding when the two surfaces are homogeneously connected over an area of diameter d . For this case the displacement may be found by means of the formulas for stress and strain in a semi-infinite body loaded at the surface, and for loads distributed over rectangular areas the average displacement has been calculated (reference 13). Substituting a square of sides s for a circle with diameter $d = 1.28s$, both of which have the same area, it is found that for bolts in double shear

$$\delta = 2(0.5 P/Es) 0.91 = 1.03 P/Ed$$

This calculation gives too small a value for the displacement in the case of bolt or rivet connections because the bolts or rivets are not welded to the plate. On the contrary, a loading of the joint must produce openings between the bolt and the plate.

Another estimate may be made as follows by assuming that the bolt is completely built in at distances greater than gd , g being a certain parameter, from the common surfaces of the plate and the straps. The bolt is then in double shear, as shown in figure 4(b), and

$$\delta = (P/Ed) (3.7g + 6.8g^3)$$

and taking different values of g it is found that

for $g = 0.3$	$\delta = 1.3 P/Ed$
$g = 0.4$	$\delta = 1.9 P/Ed$
$g = 0.5$	$\delta = 2.7 P/Ed$
$g = 0.6$	$\delta = 3.7 P/Ed$

The coefficients can be determined only by tests, and provisionally a value of 3 is assumed to be reasonable. Much depends on how closely the bolt fits the hole and if the hole is larger than the bolt the displacement will obviously be greatly increased.

(3) Interpolation.— By writing

$$\delta = (P/Ed) f$$

and plotting f as a function of the ratio d/t_2 for very large and very small values of this ratio, the values of f for medium values of the ratio may be approximately obtained by interpolation as shown in figure 5.

On dimensional grounds the displacement must be given by a formula of this type, where f is a nondimensional function of the ratios between the diameter and the thicknesses of the plate and the straps. The width of the plate also enters into this function, but if the width is large in comparison with the diameter the effect of variations in the width is negligible.

3.3 Comparison with Tests

Volkerson has measured the deformation for single dural rivets and gives diagrams for a coefficient n defined by the equation $\delta = P/n$ and by writing

$$\delta = (P/E1)F$$

where f is a function of the relative dimensions $f = Ed/n$

With a value of E equal to 7000 kilograms per square millimeter¹ the following results are obtained from his diagrams:

t_1 (mm)	t_2 (mm)	d (mm)	n (kg/mm)	f
1	1	5	6,000	5.83
1	1	4	4,400	6.37
1	1	3	3,000	7.00
1	1	2.6	2,400	7.59
2	2	5	8,500	4.12
2	2	4	5,900	4.75
2	2	3	4,000	5.25
3	3	5	11,200	3.12
3	6	4	7,400	3.78
3	6	3	4,400	4.78

The values of f are shown in figure 6 as a function of the ratio d/t_2 .

The following results given by Cassens also are shown in the same figure on the assumption that the tests were made on rivets in double shear:

$d = 5$ mm	$n = 100,000$ kg/cm
$d = 4$ mm	$n = 50,000$ kg/cm
$d = 3$ mm	$n = 46,000$ kg/cm

¹This corresponds to 10^7 psi.

No information is given on the test methods employed. Volkerson admits variations up to about 25 percent for the individual samples from the average of six, and, where so much depends on the workmanship, this is not unreasonable. It is obviously more serious that the test results are not in agreement with the dimensional law, which necessitates that all the points should be on a continuous line in figure 6. This was not investigated, and it is stated that the deformations are proportional to the loads up to 17 percent of the ultimate for $d = 5t_2$ and up to 46 percent of the ultimate for $d = 0.7t_2$. A more detailed investigation of Volkerson's results shows that the proportional limit corresponds either to bearing stresses up to 32 kg/mm^2 or to shearing stresses up to 13 kg/mm^2 . Only for very large diameters d in comparison with the thicknesses t was the limit found to be at appreciably lower stresses, and this could be expected because the buckling of such thin plates takes place. In this connection it should be noted that Pleiner has observed permanent deformations due to bearing stresses above 12 to 15 kg/mm^2 in the plates. Since these deformations are not proportional to the loads, the limits given by Volkerson therefore appear to be high. The deformations, however, are probably not greatly in excess of the limit of proportionality.

The disagreement with the dimensional law can be explained by gaps in the rivet holes or by a different type of nonlinear deformation. The most reasonable explanation, however, is the difference in the action of friction for large and small rivet diameters. Montgomery (reference 2) has pointed out in an article that, for steel rivets, "In fact, the whole series of experiments showed that the adherence factor had not the importance in the thicker plates which it had in the case of thinner material." This statement means that for constant thickness of the plates, but variable diameter of the rivets, the frictional resistance is comparatively greater for large than for small rivet diameters. This is in agreement with the Volkerson results and might explain the disagreement with the dimensional law.

If, now, comparisons are made with the results of the theoretical analysis given in 3.2, it can be seen that for a small rivet diameter there is fair agreement with the Volkerson tests. For large diameters only did the tests give considerably less displacement than that given by the theory, thus indicating considerable frictional resistance.

Since the main point here is to obtain a formula giving the correct order of magnitude,

$$f = a(d/t_2 + d/2t_1) + b$$

may be taken as an average where $a = 0.8$ and $b = 2.5$, and the straight lines corresponding to $t_1 = t_2$ and $t_1 = t_2/2$ are shown in figure 6.

By writing

$$\delta = Pf/Ed = cP\delta_0 = cPl/EA$$

the coefficient $c = Af/l\delta$ used in the general theory is obtained

where

A cross section of plate

l spacing of rivets or bolts

and

d diameter of rivets or bolts

From the approximate formula given above for f it is found that

$$c = (A/l) (0.4/t_1 + 0.8/t_2 + 2.5/d)$$

The only other test series that can be used for the determination of the coefficient c is given by Batho in his original paper (reference 1), and in the Steel Structures Committee Reports (reference 6). From tests on 1/2-inch to 7/8-inch steel rivets spaced 4 inches apart and joining 3- by 5/8-inch plates with 3- by 5/16-inch straps, Batho found the empirical relation

$$c = P/(10^5 \times d^2/4) \quad (\text{Batho used } S \text{ for } c)$$

where

P total load on the joint, pounds

and

d rivet diameter, inches

The coefficient c is deduced from theory that is valid only below the limit of proportionality and c should then depend only on the relative dimensions and not on the load. The variation of c with the load may have been caused by frictional effects and by nonlinear deformations within the range of applied load.

Batho's formula for c cannot be directly compared with the formula based on the theory given above and the Volkerson tests, because it involves P and no other dimension apart from the rivet diameter. Batho

has pointed out that the indirect way of determining the coefficient c does not give accurate results and the tests indicate a value of c which is considerably less than that to be expected from the foregoing theory and the results of Volkerson. Even at loads equal to one third of that at failure the value of c is only one fourth to one fifth of that to be expected, and for higher loads the experimental values of c are increasing very rapidly.

The explanation may be that, for the lower loads, the entire load is carried by friction and then the corresponding stiffness of the rivets is very much increased.

It is not, however, reasonable to base the design of light-alloy structures on these tests on hot riveted structures because these must involve considerably more friction than is to be expected with cold rivets or bolts.

The formula based on the Volkerson tests is recommended for the design of light-alloy structures until new tests have been made.

3.4 Displacements above the Limit of Proportionality

Mathematical analysis cannot give the displacement of rivets or bolts for loads above the limit of proportionality. The only test series published, which gives general results for light-alloy rivets, appear to be of Volkerson.

Generally speaking, if the diameter is large in comparison with the thickness, the joint will fail due to bearing stresses after large displacements which are primarily due to deformation of the plates. Very thin plates will fail by buckling and, according to Fleines, this occurs if d is greater than $5t$, provided the plates are not supported by nuts or rivet heads.

The following data have been taken from Volkerson's work and are shown in figures 7(a), 7(b), 7(c), and 7(d). The tests refer to dural rivets with dimensions given in 3.3.

Let

- P_1 represent limit of proportionality for the rivet, from which the corresponding bearing and shear stresses are calculated
- P_2 , ultimate load at failure from which the corresponding bearing and shear stresses are calculated
- δ_2 , ultimate displacement at failure

and

S value of the ordinate at the load axis for the tangent to the upper part of the displacement curve. (See fig. 7(a).)

The bearing and shear stresses for the loads P_1 and P_2 are plotted as functions of the ratio d/t_2 and those corresponding to the load S are also plotted in the same way. It is found that on an average $S = 0.82 P_2$ with variations from 0.86 to 0.76 and in one exception to 0.71. Failure for d greater than $3t_2$ seems to be due to bearing stresses with a maximum value of 140 kilograms per square millimeter and for smaller diameters is due to shear stresses with an average value of about 29 kilograms per square millimeter.

For $d = 3t_2$ the limit of proportionality seems to be at bearing stresses of about 32 kilograms per square millimeter, and decreases both for larger and smaller diameters as shown in figure 7(b). For very small diameters the limit of proportionality corresponds to shear stresses of about 13 kilogram per square millimeter.

The displacement at the limit of proportionality can be found from

$$\delta_1 = (P_1/Ed)f$$

where f is the quantity discussed in 3.2 and 3.3.

Let the displacement at failure be

$$\delta_2 = (P_2/Ed)f_2$$

where f_2 is a similar function of the relative dimensions. The quantity f_2 has been calculated from the given test results and is shown in figure 7(d) as a function of the ratio d/t_2 . The experimental points in this figure very nearly lie on a smooth curve, and there is actually better agreement than for f below the limit of proportionality. If P_2 and f_2 are known, the ultimate displacement δ_2 can now be found for any size of rivet.

In this way the displacement in the high region and the low region is obtained as a function of the load, and it is only necessary to join the corresponding two straight lines by a smooth curve. It is not necessary to determine more points on this curve directly from Volkerson's tests because it is more important to know their order of magnitude than their accurate values. The curve shown in figure 7(a) is for the case where $d = t_2$. The nonlinear part of the displacement is found to be comparatively much greater for larger diameters.

The continuous curve representing the displacement is perhaps a little misleading, and for most practical purposes the displacement is more adequately represented by a discontinuous (or dotted) curve.

3.5 Test Methods

Volkersen made the plate continuous with the side straps attached to it as shown in figure 8 and measured the extension between the points A_2 and C_1 . A correction was then made for the normal extension in the plate ($A_2 - B_2$) and the straps ($B_1 - C_1$). Pleines measured the extension between the points D_1 and D_2 without any correction. At first sight it would appear reasonable to measure the displacement between points E_1 and B_2 to obtain the local "bolt + hole deformation" directly. This, however, would necessitate a correction in the original equations as follows.

The elongation of the straps between B_1 and B_1^1 (see fig. 9) was previously denoted by

$$\lambda_2 = b_2 R_2 \delta_0$$

The total tensile force in the strap for the length B_1 to A_1 is, however, equal to

$$R_1 = R_2 + P_2$$

and the correction expression for the elongation should therefore be

$$\lambda_2 = \delta_0 (b_2 R_2 + b_2^1 P_2)$$

and similarly for the length of plate B_2^1 to C_2^1 the load P_2 enters into the expression for the elongation,

$$\lambda_2 = \delta_0 (a_2 C_2 + a_2^1 P_2)$$

where the coefficients a_2^1 and b_2^1 take account of the additional elongation in the length when the direct pressure on the hole gives tension in the plates at both sides of the hole.

With the bolt + hole deformation measured between the points B_1 and B_2 included in δ_2 ,

$$\delta_2 = c_2^1 P_2 \delta_0, \text{ and so forth}$$

But

$$\delta_2 + \lambda_2^1 = \lambda_2 + \delta_3$$

and using this relation

$$c_2^1 P_2 + a_2 Q_2 + a_2^1 P_3 = b_2 R_2 + b_2^1 P_2 + c_3^1 P_3$$

which may also be obtained from the original equation

$$c_2 P_2 + a_2 (P_1 + P_2) = b_2 (P - P_1 - P_2) + c_3 P_3$$

by writing

$$c_2 = c_2^1 - b_2^1$$

and

$$c_3 = c_3^1 - a_2^1$$

These corrected coefficients c may be found directly by determining the extension between the points A_1 and C_2 on the test specimen since the connection is made by a single bolt. These points should be situated sufficiently far from the bolt for no appreciable strain to occur beyond the points. Diagonal gaging should be avoided, and to reduce the number of gages a "bridge" may be built up between the two straps as shown in figure 10. For testing one bolt, two gages - one on each side - are then needed.

3.6 Deformation of Plate and Straps

If the effect of the hole be disregarded

$$\lambda = Rl/EA$$

where A is the cross section and l is the distance between the bolts as shown in figure 11. So far as is known, no direct tests on the additional elongation due to the hole are available in published work. If the diameter (d) of the hole is not too large in comparison with the width (h) of the plate, an estimate may, however, be made in the following way. A rectangular hole of area $d \times nd$ is substituted for the circular hole and the extension is calculated on the basis that the stress is uniformly distributed both at the complete section and at the reduced section. This gives

$$\lambda = Rl/EA^1$$

where the average effective section is

$$A^1 = A / \left\{ 1 + nd^2/l (h - d) \right\}$$

A comparison with the stress distribution given by Coker and Filon (reference 12, p. 489) indicates a value of the coefficient n equal to 2.5 to 3. Their tests were made on plates with open holes and, if the holes were filled by bolts, the stress distribution would be more uniform and n correspondingly reduced. Possibly n equal to 1.5 to 2 would give a result that is more nearly correct. If the holes are very closely spaced, the effective section is probably not appreciably different from the minimum section $t(h - d)$.

3.7 Modifications in the Theory for Load Distribution for Loads

above the Limit of Proportionality

Above the limit of proportionality the equations that determine the load distribution are no longer linear and, although an exact solution may be formally obtained by treating δ as a nonlinear function of P , the computational work would then be very severe. The results may, however, be obtained to any required degree of accuracy in the following simple way, provided the load-extension curve is known. Assume that the load on the i^{th} bolt is P_i and then near this value

$$\delta_i = k_i (P_i - S_i) \delta_0$$

where the meaning of the constants k_i and S_i may be seen from figure 12. The quantity k is proportional to the reciprocal of the tangent modulus in the same way that c is proportional to the reciprocal of the modulus of elasticity (E) at low loads. On the assumption that nonlinear deformations occur only in the bolts and at the holes and not in the sections of the plates between the holes, the equations

$$\delta_i + \lambda_i^1 = \lambda_i + \delta_{i+1}$$

then give

$$k_1 (P_1 - S_1) + a_1 (P_1 + P_2 + \dots + P_n) = b_1 (P - P_1 - P_2 - \dots - P_n) + k_{1+1} (P_{1+1} - S_{1+1})$$

that is,

$$(a_1 + b_1 + k_1) P_1 - k_2 P_2 = b_1 P + (k_1 S_1 - k_2 S_2)$$

$$(a_2 + b_2)P_1 + (a_2 + b_2 + k_2)P_2 - k_3 P_3 = b_2 P + (k_2 S_2 - k_3 S_3) \text{ and so forth}$$

These equations differ from those that are correct only below the limit of proportionality in the presence of terms of the type $k_1 S_1 - k_2 S_2$ and in that k now replaces c . In order to determine the values of S and k , the bolt loads may be assumed to be in the neighborhood of the average load P/n , and in most cases recourse to a second approximation will not be necessary. The corresponding value of k for all the bolts may then be obtained from the load-extension curve. The terms $(k_1 S_1 - k_{1+1} S_{1+1})$ are then zero and the equations are identical with the original ones, except that k now replaces c .

When all the bolt loads have been determined in this way, more accurate values may be found by substituting the corresponding values of S and k for each bolt into the complete equations given above. The load distribution may be found to any required degree of accuracy by the repetition of this process.

It appears from the Volkerson tests that at half the ultimate load the value of k is about five times that of c in the particular case of thick bolts, that is, at relatively large values of d/t . If, for example, $a = b = 1$ and $c = 2$ at low loads, a value of $k = 10$ may be assumed to be correct for loads at half the ultimate. For five bolts $c = 2$ gives

$$P_1 = P_5 = 0.319 P$$

$$P_2 = P_4 = 0.136 P$$

and

$$P_3 = 0.091 P$$

while $k = 10$ gives as a first approximation

$$P_1 = P_5 = 0.235 P$$

$$P_2 = P_4 = 0.182 P$$

and $P_3 = 0.166 P$

The value of k increases very rapidly in the neighborhood of the ultimate load and then, according to Volkerson's tests, a value of $k = 50$ (or more) is not unreasonable for a value of $c = 2$. With $k = 50$ it is found that

$$P_1 = P_5 = 0.208 P$$

$$P_2 = P_4 = 0.196 P$$

and $P_3 = 0.192 P$

These results show the extent to which the loads are more uniformly distributed when there are deformations beyond the proportional limit. The design of a joint should not, however, be based on these equalized loads because the actual behavior of each individual bolt (or rivet) is likely to be irregular near the ultimate load. It is safer to base the design on values of k corresponding to medium loads.

3.8 Symmetrical Joints

When there is symmetry, it is convenient to number the bolts from the axis of symmetry and, for example, in a joint with 8 bolts the numbering is then

$$4 \text{ (end), } 3, 2, 1, 1, 2, 3, 4 \text{ (end)}$$

If all the sections of the plate and straps are the same

$$c_1 = c_2 = \dots = c$$

The total number of bolts is assumed to be $2n$, and the equations valid up to the limit of proportionality are

$$P_1 = P_1$$

$$P_2 = P_1 + (2/c) P_1$$

$$P_3 = P_2 + (2/c) (P_1 + P_2)$$

$$P_4 = P_3 + (2/c) (P_1 + P_2 + P_3), \text{ and so forth}$$

and P_1 may be found from the equation

$$2(P_1 + P_2 + \dots + P_n) = P$$

after expressing P_i in terms of P_1 . The bolt loads for joints with a large number of bolts are shown in figure 14 for values of c equal to 5, 10, 20, and 40.

If, now, a certain number of the bolts - say from $(i + 1)$ - carry loads above the limit of proportionality while those up to i carry loads below this limit, an approximate solution may be found as follows.

Assume the displacement below the limit of proportionality to be

$$\delta_1 = c P_1 \delta_0$$

and for all loads above to be

$$\delta_1 = k (P_1 - S) \delta_0$$

where k and S are constants.

The continuous load-extension curve is thus replaced by two straight lines as shown in figure 13. The assumed limit of proportionality is at the load $S_0 = Sk / (k - c)$, and by a proper choice of the second line this value will be greater than P_1 . On the other hand, however, the value of k so determined will be much smaller than that corresponding to loads near the ultimate.

If the i^{th} bolt carries a load that is just equal to S_0 , the displacement at this bolt may be expressed by either of the preceding formulas. The equations for the first i bolts are then

$$P_1 = P_{1-1} + (2/c) (P_1 + P_2 + \dots + P_{1-1})$$

as before, and for the succeeding bolts are

$$P_{1+1} = P_1 + (2/k) (P_1 + P_2 + \dots + P_1)$$

$$P_{1+2} = P_{1+1} + (2/k) (P_1 + P_2 + \dots + P_{1-1}), \text{ and so forth}$$

As an example, a symmetrical joint with 12 bolts may be considered and the results for $c = 5$ and $k = 20$ are given below.

(1) $P_6 = S_0$:

$$\begin{aligned} P_1 &= 1.0000 P_1 = 0.0684 S_0 \\ P_2 = P_1 + 0.4 P_1 &= 1.4000 P_1 = 0.0957 S_0 \\ P_3 = P_2 + 0.4 (P_1 + P_2) &= 2.3600 P_1 = 0.1613 S_0 \\ P_4 = P_3 + 0.4 (P_1 + \dots + P_3) &= 4.2640 P_1 = 0.2914 S_0 \\ P_5 = P_4 + 0.4 (P_1 + \dots + P_4) &= 7.8736 P_1 = 0.5380 S_0 \\ P_6 = P_5 + 0.4 (P_1 + \dots + P_5) &= 14.6326 P_1 = 1.0000 S_0 \\ 0.5 P = P_1 + P_2 + \dots + P_6 &= 31.5302 P_1 = 2.1548 S_0 \end{aligned}$$

(2) $P_5 = S_0$:

$$\begin{aligned} P_1 &= 1.0000 P_1 = 0.1270 S_0 \\ P_2 = \text{similar expressions} &= 1.4000 P_1 = 0.1778 S_0 \\ P_3 = \text{to those above} &= 2.3600 P_1 = 0.2997 S_0 \\ P_4 &= 4.2640 P_1 = 0.5415 S_0 \\ P_5 &= 7.8736 P_1 = 1.0000 S_0 \\ P_6 = P_5 + 0.1 (P_1 + \dots + P_5) &= 9.5634 P_1 = 1.2146 S_0 \\ 0.5 P = P_1 + P_2 + \dots + P_6 &= 3.3606 S_0 \end{aligned}$$

(3) $P_4 = S_0$:

$$\begin{aligned}
 P_1 &= 1.0000 P_1 = 0.2345 S_0 \\
 P_2 &= \text{similar expressions} = 1.4000 P_1 = 0.3283 S_0 \\
 P_3 &= \text{to those above} = 2.3600 P_1 = 0.5535 S_0 \\
 P_4 &= 4.2640 P_1 = 1.0000 S_0 \\
 P_5 &= P_4 + 0.1 (P_1 + \dots + P_4) = 5.1664 P_1 = 1.2116 S_0 \\
 P_6 &= P_5 + 0.1 (P_1 + \dots + P_5) = 6.5854 P_1 = 1.5444 S_0 \\
 0.5 P &= P_1 + P_2 + \dots + P_6 = 4.8723 S_0
 \end{aligned}$$

Similar results may be obtained for P_3 , P_2 , and P_1 equal to S_0 thus giving the loads carried by the bolts at various applied loads as shown in figure 15(a). For intermediate values the loads carried by the bolts may be found simply by linear interpolation. The bolt loads are also shown in figure 15(b) as functions of the total load for this particular case.

The example shows that in a joint with many bolts the load distribution is far from being uniform even when the deformations are nonlinear.

The time taken to complete the calculations and the drawings was $1\frac{1}{2}$ hours, which clearly shows that an analysis of this kind can be made in a reasonable time.

3.9 Reinforcing of Main Plate by Side Plates

If the main plate is reinforced by side plates, as shown in figure 16(a), these will to some extent behave as straps in the usual way, but the deformation at the main bolt will be slightly altered. The loads carried by the bolts are denoted by

$$P_1, P_2, P_3, \text{ and so forth}$$

the loads in the sections of the middle plate by

$$Q_1 = P_1, Q_2 = P_1 + P_2, Q_3 = P_1 + P_2 + P_3, \text{ and so forth}$$

and the loads in the sections of the two side plates taken together by

$$R_1 = P - Q_1, R_2 = P - Q_2, R_3 = P - Q_3, \text{ and so forth}$$

as shown in figure 16(b). The displacement at the first bolt was previously denoted by $C_1 P_1 \delta_0$ and, because the side plates, an additional term that is proportional to P , must now be introduced. (See fig. 16(c).)

This additional term consists of two parts, one of which is due to bending of the bolt and the other due to the compression arising from the bearing stresses on the side plates. The first gives a displacement in the same direction as P_1 , and the second gives a displacement in the opposite direction because the side plates slip back relatively to the middle plate. The main bolt will usually be strong in comparison with the plates and the displacements due to bending will therefore be small in comparison with those due to bearing. The total displacement due to P_1 will therefore be negative and hence

$$\delta_1 = (c_1 P_1 - gP) \delta_0$$

where g is a positive constant. The equation

$$\delta_1 + \lambda_1^1 = \lambda_1 + \delta_2$$

now gives

$$(a_1 + b_1 + c_1) P_1 - c_2 P_2 = (b_1 + g) P$$

while the other equations are as before

$$(a_2 + b_2) P_1 + (a_2 + b_2 + c_2) P_2 - c_3 P_3 = b_2 P$$

$$(a_3 + b_3) (P_1 + P_2) + (a_3 + b_3 + c_3) P_3 - c_4 P_4 = b_3 P, \text{ and so forth}$$

A more detailed discussion of the constant g is given below.

Assume, for example, that there are one bolt and three rivets, as in figure 16(a), and that

$$a_1 = a_2 = a_3 = b_1 + b_2 + b_3 = 1$$

$$c_1 = 1.5, c_2 = c_3 = c_4 = 3$$

$$g = 0.8$$

The equations are then

$$3.5 P_1 - 3 P_2 = 1.8 P$$

$$2 P_1 + 5 P_2 - 3 P_3 = P$$

$$2 P_1 + 2 P_2 + 5 P_3 - 3 P_4 = P$$

$$P_1 + P_2 + P_3 + P_4 = P$$

which give

$$P_1 = 0.557 P$$

$$P_2 = 0.050 P$$

$$P_3 = 0.121 P$$

$$P_4 = 0.272 P$$

In other words, not quite half the load - $P_1 + P_2 + P_3 = 0.443 P$ - is transferred by the rivets to the side plates and from these to the main bolt. In addition, the bearing stresses acting on the middle plate are reduced to 55.7 percent of those found when there were no side plates. If the term gP_0 is neglected, the loads are found to be

$$P_1 = 0.403 P$$

$$P_2 = 0.137 P$$

$$P_3 = 0.164 P$$

$$P_4 = 0.296 P$$

As explained, the coefficient g may be written in the form

$$g = g^1 - g^{11}$$

where g^1 represents the compression due to the bearing stresses and g^{11} represents the bending of the bolt. The deformation due to the bearing stresses has already been discussed and

$$g^1 P_{B_0} = g^1 P_1 / EA = (P/Ed) 1.3 (d/2t_1)$$

that is,

$$g^1 = 0.65 (A/t_1)$$

The bending of the bolt is due to a bending moment the value of which is approximately

$$(P/2) (e - t_1 - t_2) / 2$$

and from this by calculating the relative displacement between the centers of the side plates and the middle plate it is found that

$$g^{11} P_{B_0} = g^{11} P (1/EA) = (2/3) (P/Ed_1^4) (e - t_1 - t_2) (3t_1^2 + 6t_1 t_2 + 2t_2^2)$$

that is,

$$g^{11} = 0.43 (A/d_1 l) (t_2/d_1)^3 (e/t_2 - 1 - t_1/t_2) \left\{ 1 + 3(t_1/t_2) + 1.5(t_1/t_2)^2 \right\}$$

If the main bolt is made of steel and the plates of dural, the above constants 0.65 and 0.43 in g^1 and g^{11} should be replaced by 0.52 and 0.14, respectively. It can be seen from these expressions for g^1 and g^{11} that the latter is small in comparison with the former if the diameter d_1 of the first bolt is large in comparison with the thicknesses of the plates, which is usually the case in practice.

For the slightly different system depicted in figure 17, all the equations remain the same as before except that now $P_1 + P_2 + P_3 + P_4 = 0$ instead of P . With the same dimensions as above it is found that

$$P_1 = 0.462 P$$

$$P_2 = - 0.061 P$$

$$P_3 = - 0.127 P$$

$$P_4 = - 0.274 P$$

In other words, not quite half the load is transferred by the three rivets to the middle plate and from this to the main bolt. The bearing stresses are correspondingly reduced to 53.8 percent of those found when no middle plate is added for the strengthening of the lugs.

4. SINGLE SHEAR JOINTS

It has already been pointed out that in single shear there is local bending in the plates, and the consequent tilting of the rivets increases the displacement for a given load. Even if the rivets are designed for the same bearing and shear stresses as for rivets in double shear, the displacements must be expected to be larger. If this additional displacement did not occur, the results already found for double shear would be directly applicable to single shear, and by writing the displacement for loads below the limit of proportionality as

$$\delta = cP\delta_0 = cP (l/EA)$$

it would be found that

$$c = (A/l) (1.6/t + 5/d)$$

for two plates of the same thickness riveted together. The actual displacement is probably larger and this will be most noticeable for large diameters when the tilting of the rivets is of greatest importance.

A theoretical analysis of the load distribution on the rivets is given below and the value of c is assumed to be known. This analysis is very much complicated by the bending of the joint as a whole, and the results may be summarized as follows:

1. The load distribution on the rivets is dependent on the total load even below the proportional limit (instead of being independent, as for double shear joints)
2. For the same value of c the load distribution at small loads shows even greater nonuniformity than that for double shear joints
3. The load distribution becomes more uniform as the loads are increased and in some cases is better than that for double shear joints even below the limit of proportionality
4. At higher loads the load distribution approximates to that for double shear joints, provided the elastic limit or the ultimate strength has not already been reached

5. The results for double shear joints are therefore recommended for use in design because only the load distribution at the highest allowable loads are of interest, and this will usually be a safe approximation.

As a preliminary to the detailed analysis the bending of a single plate outside the joint as shown in figure 18 is first considered. The differential equation for the elastic line is

$$Y_{xx} = Py/EI$$

where P is the offset tensile load and EI is the appropriate bending stiffness. This gives the solution

$$y = g \exp(-\theta x/l)$$

where g is the offset of the elastic line at $x = 0$ and θ is a non-dimensional quantity equal to $l(P/EI)^{1/2}$ or $(l/t)(12f/E)^{1/2}$ in terms of the average axial stress $f = P/A$ in the plate. The slope of the elastic line at $x = 0$ is

$$\alpha = (g/l)\theta$$

Now consider a symmetrical joint between two plates of the same thickness t and with $2n$ rivets, the rivets being numbered from the axis of symmetry as shown in figure 19(a). Initially the plates are flat, and under the tensile load P they bend as shown in figure 19(b). At the axis of symmetry the central line of each plate is offset a distance $0.5t$ from the load axis. If the bending in the joint could be neglected, and the slope be kept as at the ends,

$$0.5t = g + \alpha(n - 0.5)l$$

approximately, and this gives

$$g = t / \{2 + (2n - 1)\theta\}$$

$$\alpha = (t/l)\theta / \{2 + (2n - 1)\theta\}$$

These formulas give an approximate indication of how the slope varies with the load, it being remembered that θ is a function of the load. In consequence the moment arms will also depend on the load, and the load distribution on the rivets is then dependent on the load even at loads below the limit of proportionality. The load distribution is, however, greatly influenced by being inside the joint, and these approximate formulas have merely been given to fix ideas.

The relation between α and g at the outer rivet is needed for a more exact solution of the problem. Consider a section originally of length l , between the $(i-1)^{\text{th}}$ and the i^{th} rivets in the left-hand side of the axis of symmetry as shown in figure 20. The tensile load carried by the plates is denoted by Q_i and R_i , and the rivet loads at the ends of the section by P_{i-1} and P_i . Then from symmetry

$$Q_i + R_i = P$$

$$Q_i = R_i = P/2$$

$$R_i = P/2 - N_{i-1}$$

and

$$R_n = P_n$$

where

$$N_i = P_1 + P_2 + \dots + P_i$$

The offset loading causes the plates to bend, and the plane ends of the section are at an angle ϕ_i to one another. Comparison between the extensions at the common surfaces of the plates then gives

$$R_i l / EA - t \phi_i / 2 + \delta_i = Q_i l / EA + t \phi_{i-1} / 2 + \delta_{i-1}$$

that is,

$$\phi_i = (1/t) \left\{ \delta_i - \delta_{i-1} + (R_i - Q_i) l / EA \right\}$$

$$= (l/EAt) \left\{ c(P_i - P_{i-1}) - 2 N_{i-1} \right\}$$

or

$$(t \theta^2 / 12 P l) \left\{ c(P_i - P_{i-1}) - 2 N_{i-1} \right\}$$

In order to produce this degree of bending, each plate must be subject to a bending moment of amount $EI \phi_i / l$.

Let y'_1 denote the average value of the ordinate of the common surface of the two plates for the section of the joint. The bending moment acting on the whole section, resulting in bending of the two plates and axial forces, is then

$$M_1 = P y'_1 = 2EI\phi_1/l + tR_1/2 - tQ_1/2$$

$$= (t/6) \left\{ c(P_1 - P_{1-1}) - 8 N_{1-1} \right\}$$

and this gives

$$y'_1 = (t/6P) \left\{ c(P_1 - P_{1-1}) - 8 N_{1-1} \right\}$$

The quantity y'_1 is sensibly zero at very small loads and the foregoing relation then shows that

$$P_1 = P_{1-1} + (8/c) N_{1-1}$$

The corresponding equations for double strap joints involve the constant $2/c$ instead of $8/c$. It follows that for very small loads the load distribution shows even greater nonuniformity for single shear joints than for double shear joints and this is due to the bending of the plates. If infinitely large loads could be applied within the limit of proportionality, angles ϕ_1 would still be finite and at such loads the equations reduce to those for double shear joints, that is,

$$P_1 = P_{1-1} + (2/c) N_{1-1}$$

In the analysis of the load distribution at intermediate loads it is convenient to replace the average ordinate y'_1 by the ordinate y_1 of the point of intersection of the tangents at the ends of the section, as shown in figure 21(a).

Now

$$y_1 = y'_1 + l\phi_1/6$$

and it follows that

$$y_1 = (t/6P) \left\{ c(1 - \theta^2/12)(P_1 - P_{1-1}) - 2(4 - \theta^2/12)N_{1-1} \right\}$$

Simple relations may now be found between the quantities y_1 if there is an even number of rivets $y_1 = 0$, and this merely confirms that the rivets on each side of the axis of symmetry carry the same load. From figure 21(b) it is clear that the following recurrence relation holds between the y_1 values,

$$y_{i+1} - 2y_i + y_{i-1} = 2\phi_i, \quad i = 2, 3, \dots (n-1)$$

and at the ends of the joint (see fig. 21(c)),

$$y_n = g - t/2 + 2a/2 = g(1 + \theta/2) - t/2$$

and

$$y_{n-1} = y_n + (\alpha + \phi_n)l = g(1 + 3\theta/2) - t/2 + 2\phi_n$$

The expression for y_1 and ϕ_1 previously found may now be substituted into these equations to give n relations between the n rivet loads and the ordinate g .

In addition

$$2(P_1 + P_2 + \dots + P_n) = P$$

and these equations taken all together suffice to determine the rivet loads P_1 and the ordinate g .

In general, the solution of the equations is rather involved and as an illustration the comparatively simple case of $n = 2$ (i.e., 4 rivets) is considered in detail. The equations are

$$y_2 = g(1 + \theta/2) - t/2$$

$$y_1 = 0 = g(1 + 3\theta/2) - t/2 + 2\phi_2$$

and

$$2P_1 + 2P_2 = P$$

or

$$g(1 + \theta/2) = t/2 + (t/6P) \left\{ c(1 - \theta^2/12)(P_2 - P_1) - 2(4 - \theta^2/12)F_1 \right\}$$

$$g(1 + 3\theta/2) = t/2 - (t/6P)(\theta^2/2) \left\{ c(P_2 - P_1) - 2F_1 \right\}$$

and

$$2P_1 + 2P_2 = P$$

These equations give

$$P_2/P_1 = 1 + \left[8 + \theta^2(10 + 3\theta)/12 \right] \left[c \left\{ 1 + 3\theta/2 + \theta^2(10+3\theta)/24 \right\} + 6\theta \right]$$

and by taking $c = 4$, the following numerical results for various values of θ may be obtained:

θ	P_1/P	P_2/P
0.0	0.125	0.375
.5	.179	.321
1.0	.200	.300
1.5	.209	.291
2.0	.213	.237
2.5	.215	.285
3.0	.215	.285
3.5	.215	.285

For very large values of θ

$$P_2 = P_1 (1 + 2/c)$$

and again this gives

$$P_1 = 0.2 P$$

$$P_2 = 0.3 P$$

as for double strap joints.

The solution for very high values of θ is of little practical interest because it corresponds to high loads. Now

$$f = E\theta^2 t^2/12l^2$$

and by taking $\theta = 2$ and $l = 10t$ it is found that $f = E/300$. Stresses in excess of this value will result in nonlinear deformations, and the formula will no longer be valid unless the rivet pitch is increased. The variation in the load on the outer rivet is shown diagrammatically in figure 22 on the basis that the loads are within the elastic limit. The actual numerical results will, of course, vary both with the number of rivets and with the value of c for the particular joint in question.

When there are several rows of rivets joining the two plates together, it is necessary only to modify the above formulas by taking A to be the area corresponding to one line of rivets.

The above table shows that with 4 rivets and $c = 4$ the load distribution on the rivets is the same for single and double shear joints if $\theta = 1$. In general the load distribution for single and double shear joints with 4 rivets is the same if

$$q = 2c/(4 + c)$$

and for larger values of q the load distribution is better for single than for double shear joints.

The equations as given above are for joints with an even number of rivets ($2n$) and for an odd number of rivets ($2n + 1$) they should be modified as follows. The central rivet is designated by the suffix o and the other rivets are designated as before. The total load is now

$$P = P_o + 2 (P_1 + P_2 + \dots + P_n)$$

instead of

$$P = 2 (P_1 + P_2 + \dots + P_n)$$

and

$$N_1 = P_o/2 + P_1 + P_2 + \dots + P_n$$

instead of

$$N_1 = P_1 + P_2 + \dots + P_n$$

At the axis of symmetry $y_1 = -y_0$ instead of $y_1 = 0$. All other general equations, however, remain unaltered. For example, in a joint with only three rivets the equations are

$$P = P_0 + 2 P_1$$

$$y_1 = (t\theta^2/12 P) \{c(P_1 - P_0) - P_0\}$$

$$y_1 = (t/6 P) \{c(1 - \theta^2/12)(P_1 - P_0) - (4 - \theta^2/12) P_0\}$$

$$y_1 = g (1 + \theta/2) - t/2$$

and

$$y_0 = -y_1 = g (1 + 3\theta/2) - t/2 + d_1$$

which give

$$P_1/P_0 = 1 + \left[8 - \theta + (4+\theta) \theta^2/12 \right] / \left[c \cdot 2(1+\theta) + (4+\theta) \theta^2/12 \right] + 6\theta$$

and by taking $c = 4$ the following numerical results for various values of θ may be obtained:

θ	P_0/P	P_1/P
0.0	0.200	0.400
.5	.250	.375
1.0	.276	.362
1.5	.290	.355
2.0	.298	.351
3.0	.304	.348
4.0	.306	.347
5.0	.304	.348
10.0	.296	.352

The single shear joint with three rivets has the same load distribution as the double shear joint; that is, $P_1/P = 1 + 1/c$ if $q = 2c/(2 + c)$, and for larger values of q the single shear joint has a better load distribution than the double shear joint, and in particular for $q = 4/3$ and $c = 4$ the load distribution

$$P_0/P = 0.286$$

$$P_1/P = 0.357$$

is obtained both for single and double shear joints, and the distribution in single shear joints is slightly improved for larger values of θ .

When there are several rows of rivets it is necessary only to make the same modification that has already been mentioned for an even number of rivets.

CONCLUSIONS

Further experimental data on the load distribution in bolted or riveted joints in light-alloy structures are needed to check the theory developed in this report and also to provide design data on bolt and rivet stiffnesses. The experimental data at present known are primarily due to Volkerson and these are not sufficient. The numerical examples given show that the load distribution does not vary greatly with the bolt (or rivet) stiffnesses and that for design purposes it is usually sufficient to know their order of magnitude. The theory may also be directly used for spot-welded structures and, with small modifications, for seam-welded structures.

The computational work involved in the methods described is simple and may be completed in a reasonable time for most practical problems.

REFERENCES

1. Batho, C.: The Partition of the Load in Riveted Joints. Jour. Franklin Inst., (Canada) 1916.
2. Montgomery, J.: Further Experiments on Large Size Riveted Joints. Engineering, vol. CXV, 1923, pp. 727 and 755.
3. Wyss, T.: Beitrag zur Spannungsuntersuchung an Knotenblechen eiserner Fachwerke. Forschungsarbeiten, no. 262 (Berlin) 1923.
4. Fleines, W.: Nietverfahren in Metallflugzeugbau. Luftfahrtforschung, vol. 7, 1930, pp. 1-72.
5. Caesens, E.: Die Nietkräfte in den Veretärkungslaschen von Biegeträger. Z.f. Flugtechnik (Berlin) 1933.

6. Steel Structures Research Committee Reports. London, first (1931), second (1934), and final (1936).
7. Findeisen, C.: Versuche über die Beanspruchungen in den Laschen eines gestossenen Flacheisens bei Verwendung zylindrischen Boltzen. Forschungsarbeiten, no. 229 (Berlin) 1920.
8. Hertwig and Peterman: The Distribution of Load among Rivets in a Line. Stahlbau, vol. 25, 1929.
9. Hovgaard: A New Theory of the Distribution of Shearing Stresses in Riveted and Welded Connections. Inst. of Naval Architects, 1931.
10. Volkersen, Olaf: Die Nietkraftverteilung in zugbeanspruchten Nietverbindungen mit konstanten Laschenquerschnitten. Luftfahrtforschung, vol. 15, 1938, pp. 41-47.
11. Portier, Henri: The Riveting of Thin Metal Plates in Aircraft Construction. Pub. Sci. et Tech. R.S.T., no 87, 1939, R.T.P. Trans. No. 1160.
12. Coker, E.G. and Filcn, L.N.G.: Photo-Elasticity. C.U.P., 1931.
13. Vogt, F.: Trans. Norwegian Ac. Sc., no. 2, 1925. English abstract in Trans. A.S.C.E., (New York) 1927, p. 554.

40-

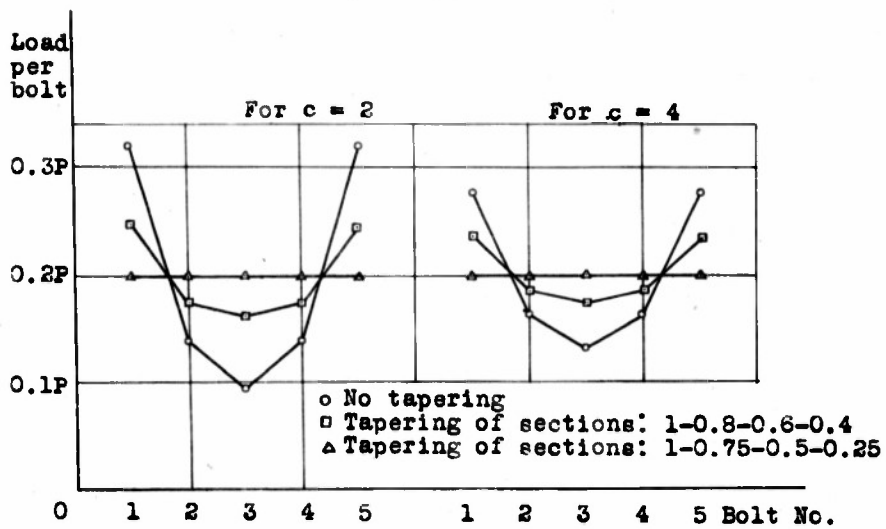
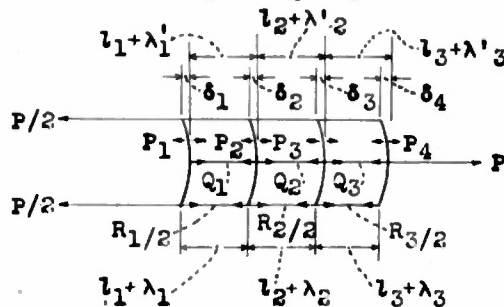
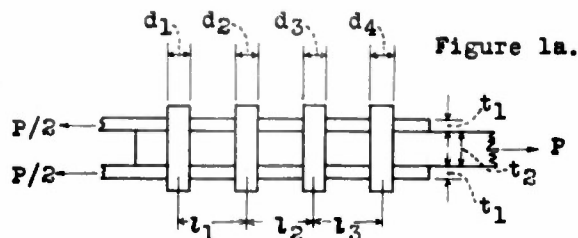

Figure 2.- Load distribution in the case of 5 bolts.

41-

Figs. 3a,b,6

NACA TM No. 1135

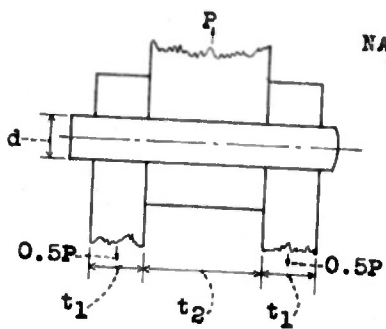

Figure 3a.

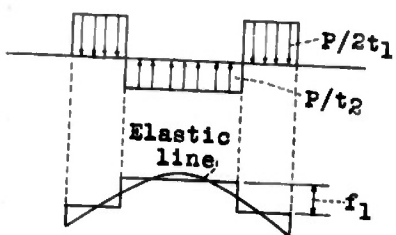

Figure 3b.

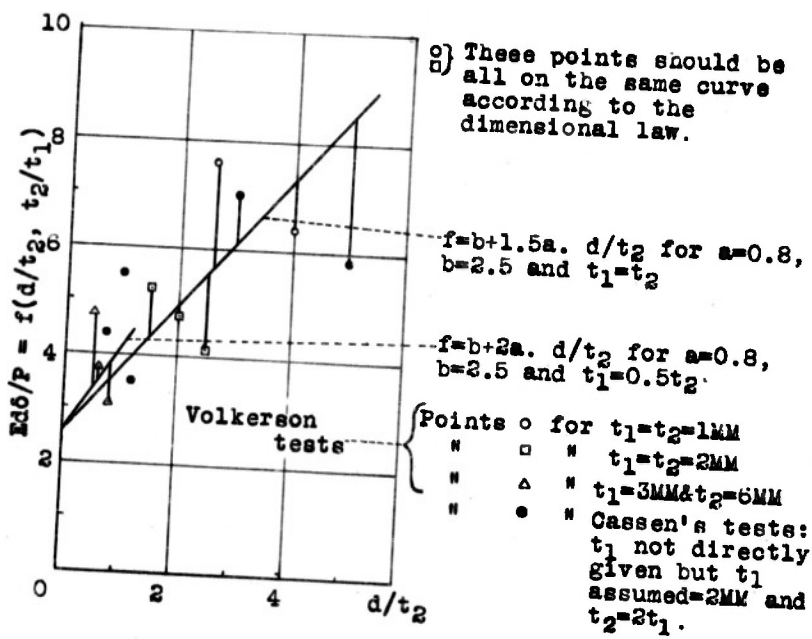

Figure 6.

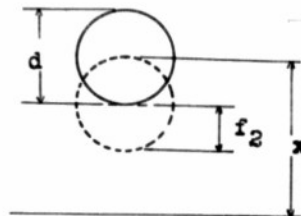

Figure 4a.

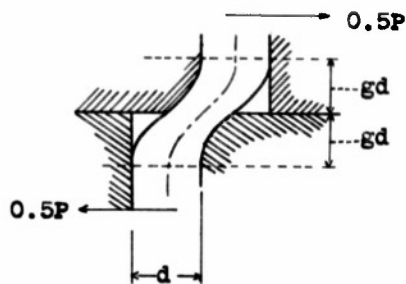

Figure 4b.

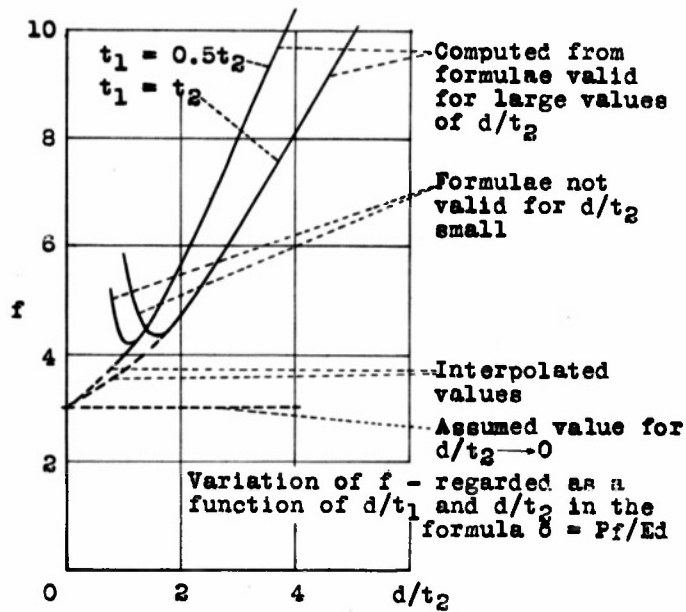

Figure 5.

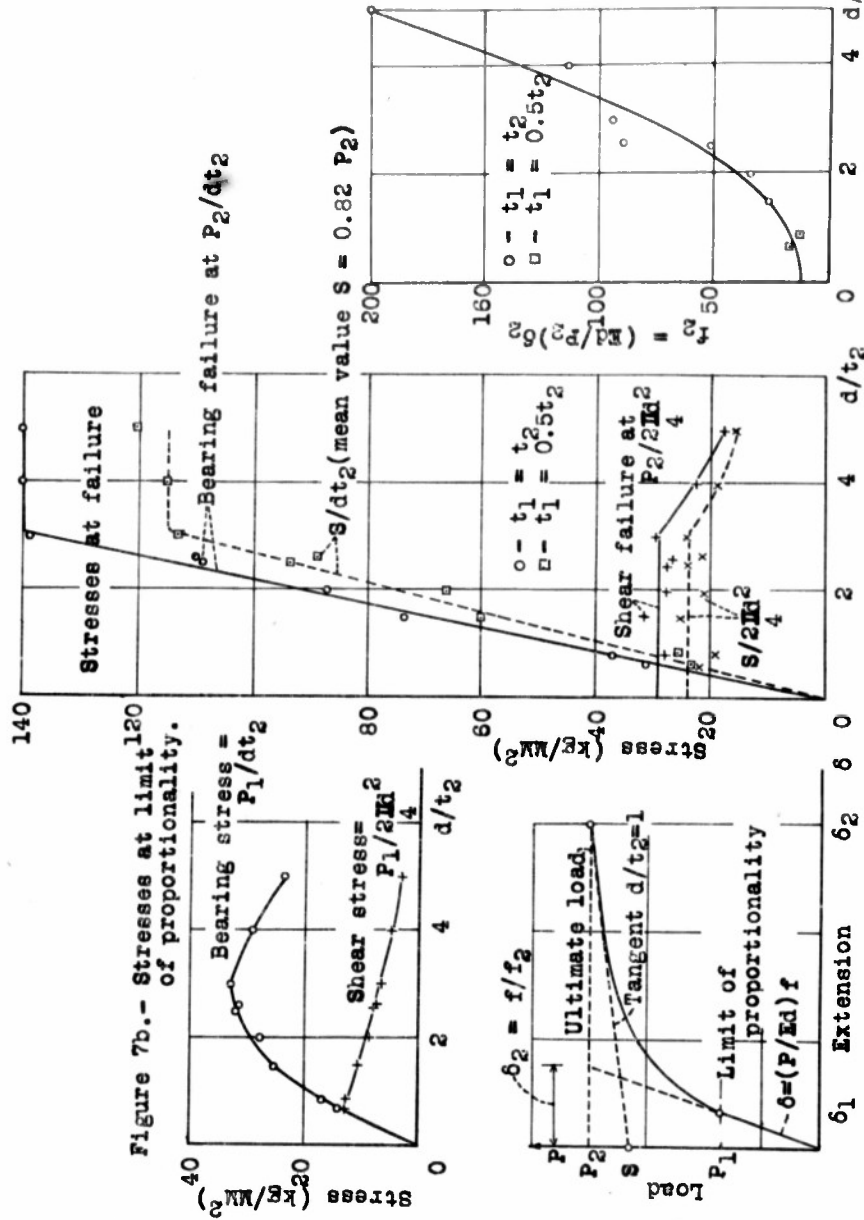

Figure 7b.- Stresses at limit of proportionality.

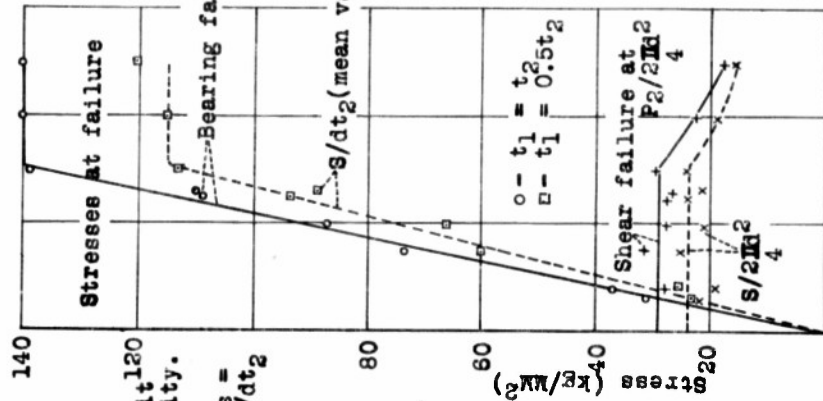
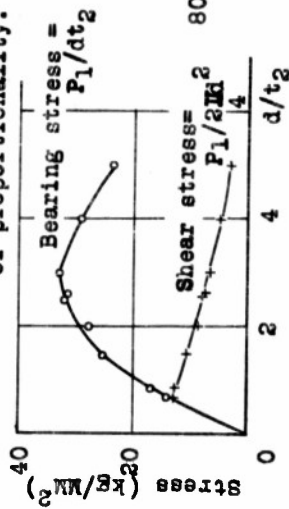

Figure 7c.

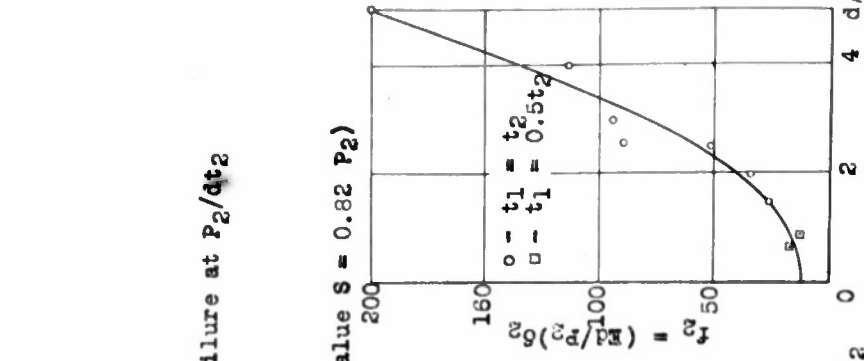

Figure 7d.

Figure 7a.- Ultimate displacement
 $6_2 = (P_2/Ed)f_2$

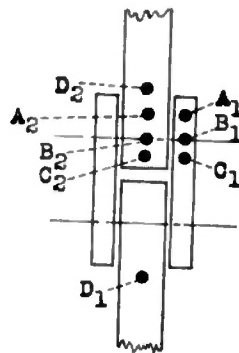

Figure 8.

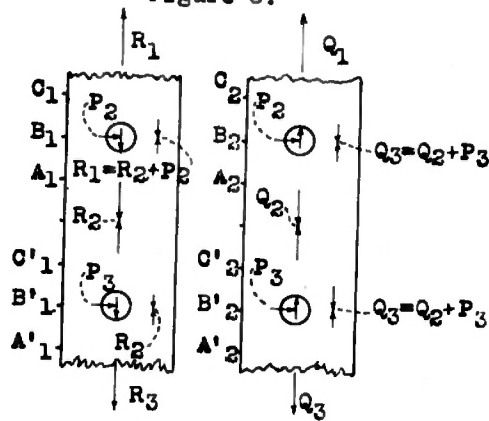

Figure 9.

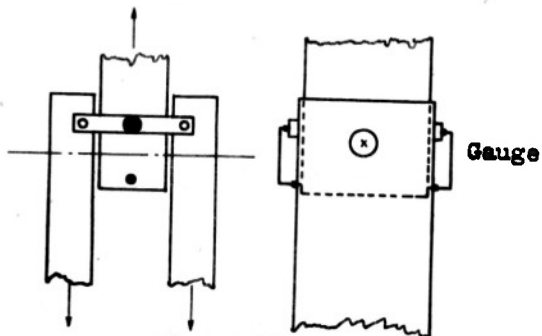

Figure 10.

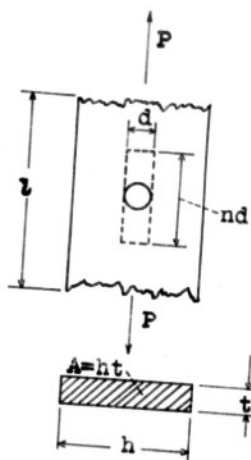

Figure 11.

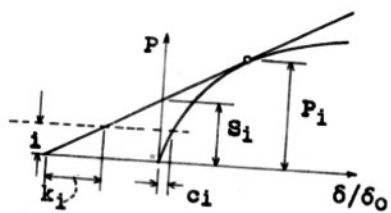

Figure 12.

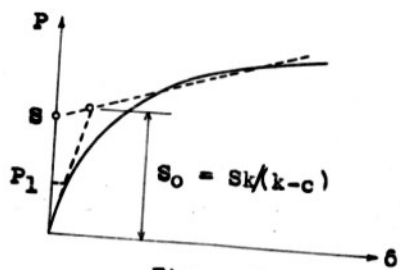

Figure 13.

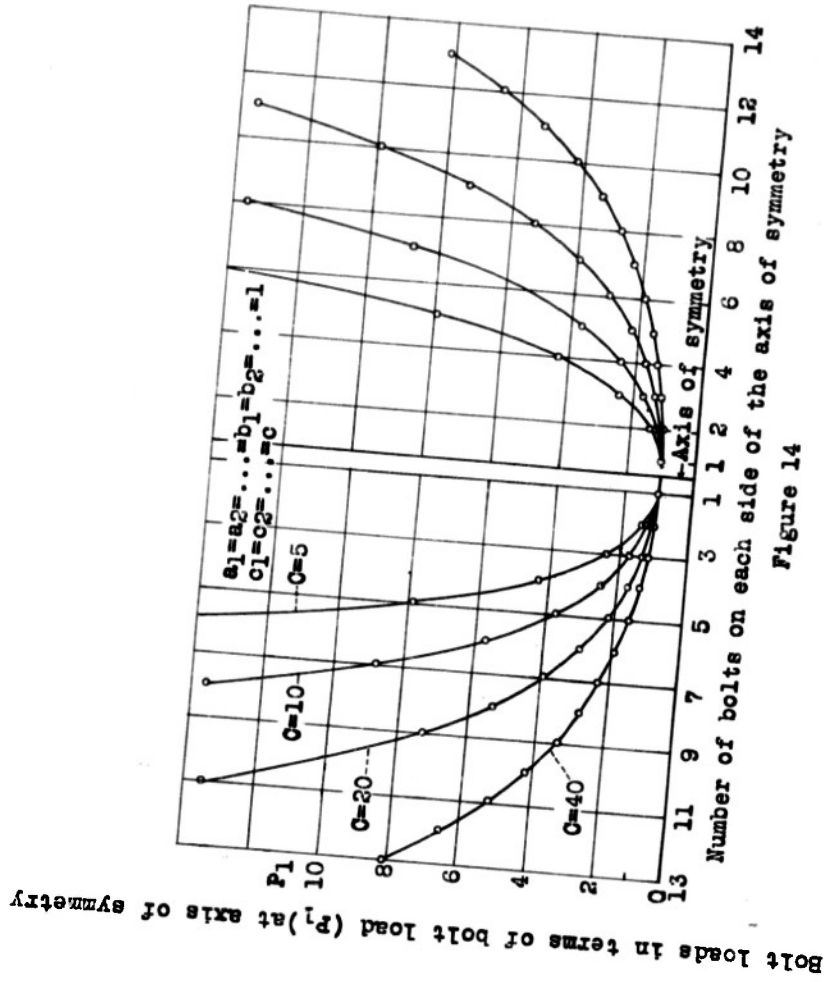

Fig. 15a,b

NACA TM No. 1135

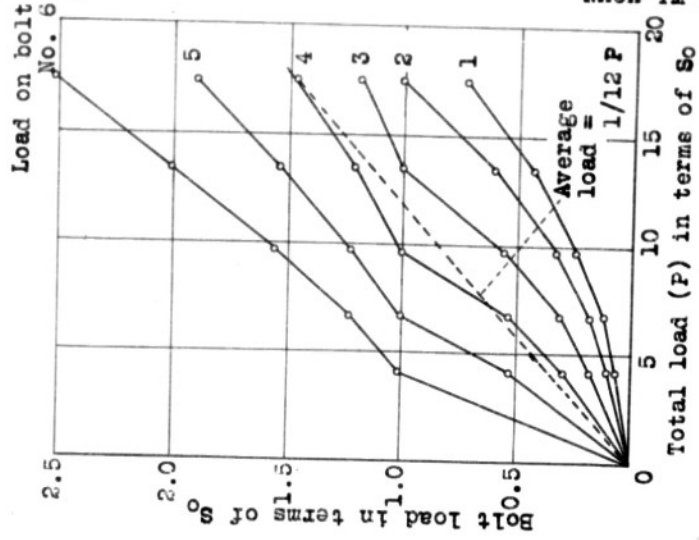

Figure 15b.

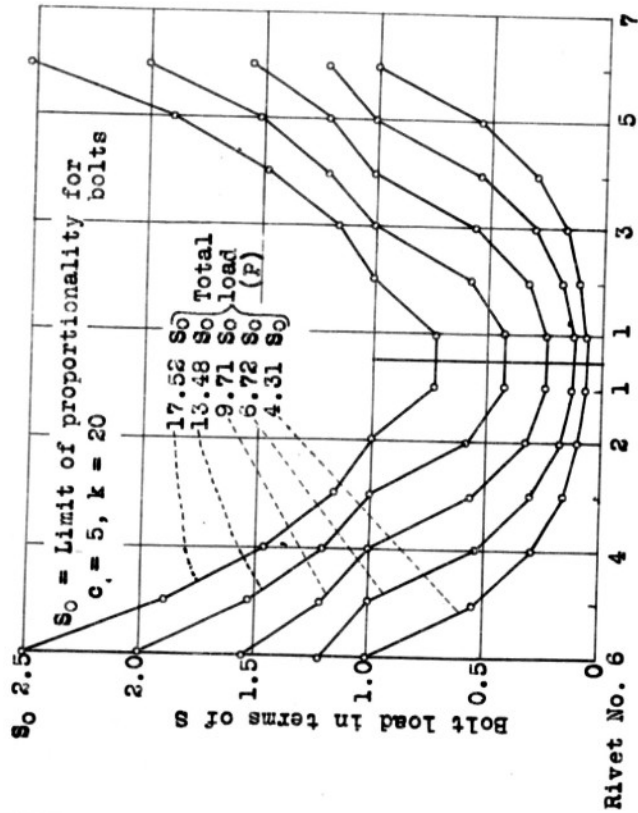

Figure 15a.

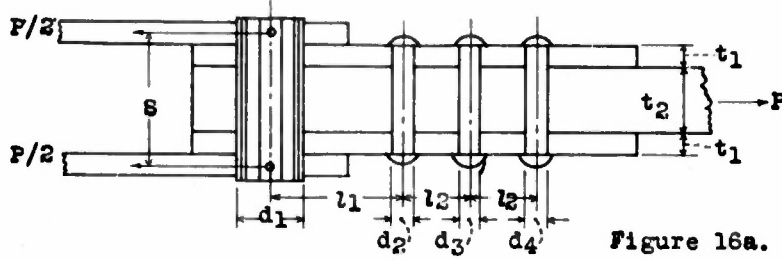

Figure 16a.

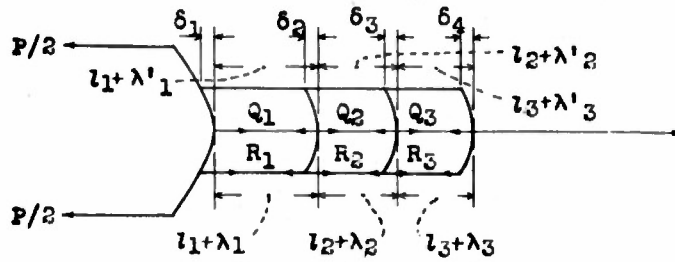

Figure 16b.

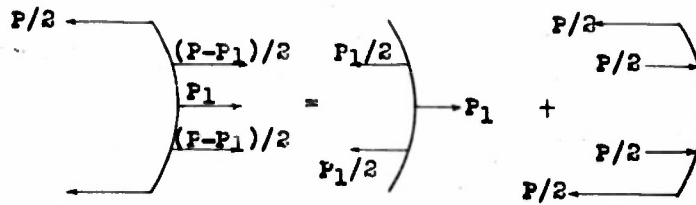

Figure 16c.

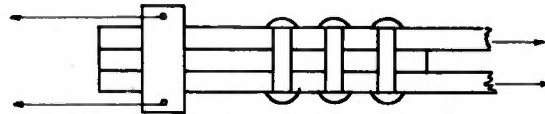

Figure 17.

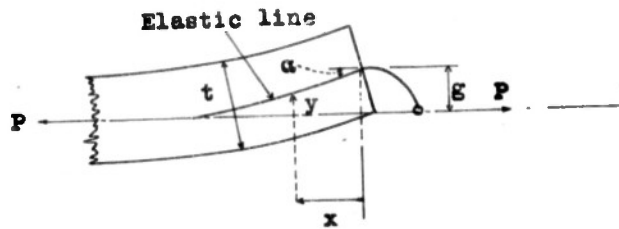

Figure 18.

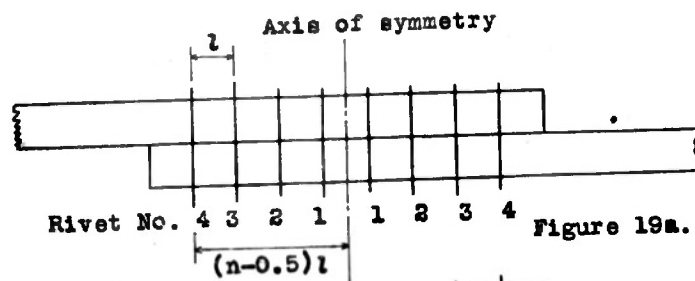

Figure 19a.



Figure 19b.

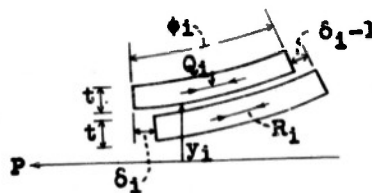

Figure 20.



Figure 21a.

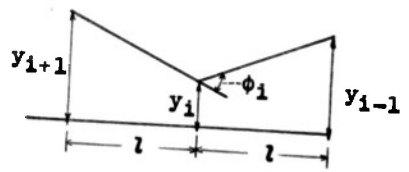

Figure 21b.

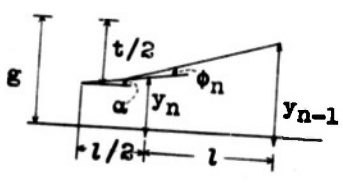

Figure 21c.

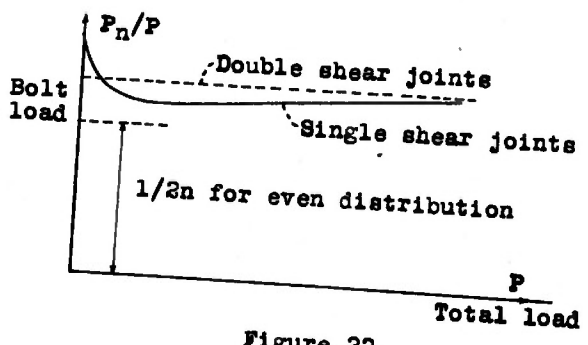

Figure 22.

REEL - C

3 0 8

A.T.I.

8 2 8 7

TITLE: The Load Distribution in Bolted or Riveted Joints in Light-alloy Structures

AUTHOR(S): Vogt, F.

ORIGINATING AGENCY: National Advisory Committee for Aeronautics, Washington, D. C.

PUBLISHED BY: Same

ATI- 8287

REVISION
/ none

ORIG. AGENCY NO.

TM-1135

PUBLISHING AGENCY NO. /

DATE	DOC. CLASS.	COUNTRY	LANGUAGE	PAGES	ILLUSTRATIONS
April '47	Unclass.	U.S.	Eng.	50	tables, diagrs. graphs

ABSTRACT:

Theory is developed for double and single shear joints and applies to loads below and beyond limit of proportionality. Assumed values for bolt stiffnesses are based on theory and experimental results and do not appreciably influence load distribution. Thus, order of magnitude is sufficient indication for design purposes. Theory is directly applicable to spot-welded structures and, with slight modifications, to seam-welded structures. Further experimental data are needed to check theory.

DISTRIBUTION: Request copies of this report only from Originating Agency

DIVISION: Stress Analysis and Structures (7)
SECTION: Structural Theory and Analysis
Methods (2)

SUBJECT HEADINGS: Joints, Bolted - Strength (54084);
Joints, Riveted - Stresses (54163.6)

ATI SHEET NO.: R-7-2-7

Air Documents Division, Intelligence Department
Air Materiel Command

AIR TECHNICAL INDEX

Wright-Patterson Air Force Base
Dayton, Ohio